

user manual

Instrukcja obsługi | Руководство пользователя
Manuel de l'Utilisateur | Betriebsanweisung
Bruksanvisning | Manual del Usuario
Betjeningsvejledning | Gebruikershandleiding
Käyttöohjeet | Manual de utilizare | Bruksanvisning
Manuale d'uso | Příručka uživatele | Navodila
za uporabo

Retain for future use
Zachować do przyszłego użytku
Сохраните для последующего
использования
A conserver pour une utilisation future
Für zukünftige Benutzung aufbewahren
Behold for senere bruk
Säilytä nämä käyttöohjeet tulevaa tarvetta marten
Opbevar manualen til fremtidig brug
Bewaren voor gebruik in de toekomst
Conservare il presente manuale a l'uso futuro
Păstrați acest manual pentru utilizare viitoare
Conservar para futuras consultas
Behall för framtida användning
Uchovejte pro další použití
Hranite za prihodnjo uporabo

Wood-Mizer®

Safety, Setup, Operation & Maintenance Manual

WB2000-USA

rev. B2.04



Safety is our #1 concern! Read and understand all safety information and instructions before operating, setting up or maintaining this machine.

Form #660_USA

**This is the original language
for the manual**

Table of Contents

Section-Page

SECTION 1	INTRODUCTION	1-1
1.1	Machine Description	1-1
1.2	Machine and Site Preparation.....	1-2
1.3	If You Need To Order Parts	1-2
1.4	If You Need Service	1-3
SECTION 2	SAFETY	2-1
2.1	Blade Handling.....	2-1
2.2	Sawmill Setup.....	2-2
2.3	Sawmill Operation.....	2-2
SECTION 3	SETUP & OPERATION	3-1
3.1.	Sawmill Setup.....	3-1
3.2	Control Overview	3-4
3.3	Joystick Control Overview	3-6
3.4	Programming the Control	3-11
3.5	Replacing the Blade.....	3-35
3.6	Tensioning the Blade.....	3-36
3.7	Tracking the Blade	3-39
3.8	Starting the Motor.....	3-41
3.9	Lube System Operation	3-43
3.10	Vision Camera	3-44
3.11	Pantograph Cable Boom.....	3-45
SECTION 4	MAINTENANCE	4-1
4.1	Wear Life.....	4-1
4.2	Cleaning and Maintenance	4-2
4.3	Power Feed	4-5
4.4	Belt Conveyor Alignment.....	4-7
4.5	Safety Devices Inspection	4-8
SECTION 5	ALIGNMENT	5-1
5.1	Bed Frame	5-1
5.2	Sawmill Head	5-8
5.3	Adjustment Of The Roller Blade Guide (718859)	5-1
5.4.	Blade Deflection	5-4
5.5.	Blade Guide Vertical Adjustment	5-6
5.6.	Blade Guide Spacing Adjustment	5-8
5.7.	Blade Guide Horizontal Adjustment	5-10

Table of Contents

Section-Page

SECTION 6	SAWMILL SPECIFICATIONS	6-1
6.1	Belt Sizes	6-1
6.2	Blade	6-1
6.3	Cutting Capacity	6-2
6.4	Motor Specifications	6-2
6.5	Noise Level.....	6-3
6.6	Overall Dimensions	6-3
6.7	Chains	6-4
6.8	Sawdust Extractor Specifications	6-4
6.9	Lube System Specifications	6-5
6.10	Hydraulic Oil Specifications	6-5
SECTION 7	LASER INFORMATION	7-1
SECTION 8	HYDRAULIC USA	8-1
SECTION 9	MOTOR BRAKE	9-1
9.1	Motor Brake Maintenance	9-1

SECTION 1 INTRODUCTION

Thank you for choosing Wood-Mizer wood processing equipment!

Wood-Mizer is committed to providing you with the latest technology, best quality and strongest customer service available on the market today. We continually evaluate our customers' needs to ensure we're meeting current wood-processing demands. Your comments and suggestions are welcome.

The present documentation contains information that should be used when preparing the machine for operation, working with it and when servicing or repairing it, as well.

1.1 Machine Description

The WB2000 sawmill is intended for sawing wood only. The sawmill must not be used for any other purposes such as cutting ice, metal or any other materials.

Using the machine correctly, you will obtain a material of the highest quality and high degree of accuracy.

The WB2000 sawmill should be operated only by an adult (over 18 year old) who has read and understood the entire operator's manual. The sawmill is not intended for use by or around children.

The WB2000 sawmill is intended to work with loading deck or similar equipment for automatic log loading and with boards or cants removal system. It is not allowed to load the log or remove already cut boards or cants manually.

The machine is built to be durable and easy to operate and maintain.

1.2 Machine and Site Preparation

The sawmill is delivered and installed at customer's premises by the Wood-Mizer Customer Service.

The major components of the WB2000 sawmill are shown in the figure below.

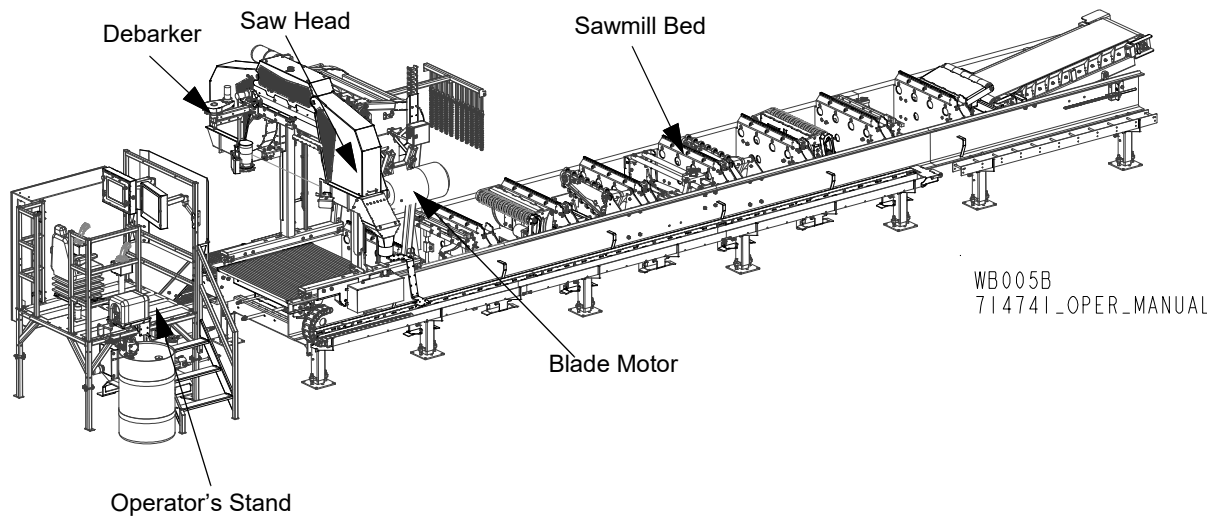

FIG. 1-0

1.3 If You Need To Order Parts

From Europe call your local distributor or our European Headquarters and Manufacturing Facility in Kolo, Nagórna 114 St, Poland at +48-63-2626000. From the continental U.S., call our toll-free Parts hotline at **1-800-525-8100**. Please have the machine identification number and your customer number ready when you call. Wood-Mizer will accept these methods of payment:

- Visa, Mastercard, or Discover
- COD
- Prepayment
- Net 15 (with approved credit)

Be aware that shipping and handling charges may apply. Handling charges are based on size and quantity of order. In most cases, items will ship on the day they are ordered. Second Day and Next Day shipping are available at additional cost.

From the continental U.S., call our toll-free Parts hotline at **1-800-525-8100**.

1 INTRODUCTION

If You Need Service

1.4 If You Need Service

From Europe call your local distributor or our European Headquarters and Manufacturing Facility in Kolo, Nagórna 114 St, Poland at +48-63-2626000. From the continental U.S., call us toll-free at **1-800-525-8100**. Ask to speak with a Customer Service Representative. Please have your machine identification number and your customer number ready when you call. The Service Representative can help you with questions about the operation and maintenance of your sawmill. He also can schedule you for a service call.

Office Hours:

Country	Monday - Friday	Saturday	Sunday
Poland	7 a.m.- 4 p.m.	Closed	Closed
US	8 a.m.- 5 p.m.	8 a.m.- 5 p.m	Closed

SECTION 2 SAFETY



This symbol calls your attention to instructions concerning your personal safety. Be sure to observe and follow these instructions. This symbol accompanies a signal word. The word **DANGER** indicates an imminently hazardous situation which, if not avoided, will result in death or serious injury. **WARNING!** suggests a potentially hazardous situation which, if not avoided, could result in death or serious injury. **CAUTION** refers to potentially hazardous situations which, if not avoided, may result in minor or moderate injury to persons or equipment. Read all safety instructions before operating this machine and observe all safety warnings!



Warning stripes are placed on areas where a single decal would be insufficient. To avoid serious injury, keep out of the path of any equipment marked with warning stripes.

Read all safety instructions before operating this sawmill and observe them during operation of the machine! Also read any additional manufacturer's manuals and observe any applicable safety instructions including dangers, warnings, and cautions.

Always be sure that all safety decals placed on the machine are clean and readable. Replace immediately all damaged safety decals to prevent personal injury or damage to the equipment. Contact your local Wood-Mizer dealer, or call Wood-Mizer Customer Service Department to order more decals.

IMPORTANT! It is always the owner's responsibility to comply with all applicable federal, state and local laws, rules and regulations regarding the ownership, operation and towing of your Wood-Mizer sawmill. All Wood-Mizer mill owners are encouraged to become thoroughly familiar with these applicable laws and comply with them fully while using or towing the mill. Always properly dispose of all sawing by-products, including sawdust and other debris, coolant, oil, fuel, oil filters and fuel filters.

Safety instructions are listed in this section by the following operations:

- Blade Handling,
- Sawmill Setup,
- Sawmill Operation,
- Sawmill Maintenance.

2.1 Blade Handling



DANGER! Always disengage the blade and shut off the sawmill motor before changing the blade. Failure to do so may result in serious injury.



WARNING! Always wear gloves and eye protection when handling bandsaw blades. Changing blades is safest when done by one person! Keep all other persons away from area when coiling, carrying or changing a blade. Failure to do so may result in serious injury.

2.2 Sawmill Setup



WARNING! Securely fasten rails of a sawmill to the floor before operating the sawmill. Failure to do so may result in serious injury or death.

WARNING! The sawmill should be set up on firm, level ground and must be fastened to the ground.



CAUTION! Changes in temperature could cause blade tension changes. Release the blade tension when the sawmill is not in use.

2.3 Sawmill Operation



IMPORTANT! The sawmill is intended for sawing wood only. See Section [6.3 Cutting Capacity](#) for log size capacities of the machine.

IMPORTANT! The sawmill's operator should get training in operation and adjustment of the machine.



DANGER! Make sure all guards and covers are in place and secured before operating. Failure to do so may result in serious injury.

Be sure the blade housing and pulley covers are in place and secured, and the safety switches located on them are engaged. Use the rubber latches to fasten the blade housing covers shut.

DANGER! Always keep hands away from moving bandsaw blade. Failure to do so may result in serious injury.

DANGER! Keep all persons out of the path of moving equipment and logs when operating the sawmill or loading and turning logs. Failure to do so may result in serious injury.

DANGER! Maintain a clean and clear path for all necessary movement around the mill and lumber stacking areas. Failure to do so may result in serious injury.

DANGER! Always be sure all persons are out of the path of the blade before starting the motor. Failure to do so may result in serious injury.

WARNING! When operating or servicing the machine, always wear eye, ear and foot protection as well as safety clothing. Failure to do so may result in serious injury.



WARNING! Secure all loose clothing and jewelry before operating the sawmill. Failure to do so may result in serious injury or death.

WARNING! Always make sure a log is clamped securely before sawing. Failure to do so may result in serious injury or death.

WARNING! Use ONLY oil specified in Section [6.9 Lube System Specifications](#) with the blade lube system. Never use flammable fuels or liquids! If these types of liquids are necessary to clean the blade, remove it and clean with a rag. Failure to do so may result in serious injury or death. When cutting in freezing temperatures, use an anti-freeze, non-flammable additive.



CAUTION! Make sure the log handling accessories are below bed level before loading a log onto the bed. Failure to do so may result in machine damage or cause misalignment.

CAUTION! Before loading a log, make sure the saw head is moved far enough so the log does not hit it. Failure to do so may result in sawmill damage.

CAUTION! Do not try to force the saw head beyond its upper and lower travel limits. Damage to the up/down system may result.



CAUTION! Never clean the blade or the blade wheels with a brush or a scraper during sawmill operation.

CAUTION! Before installation of the blade, inspect it for damage and cracks. Use only properly sharpened blades. Always handle the blade with extreme caution. Use suitable carrier equipment for transporting blades.

CAUTION! When not in use, coil the blade as described in Blade Handbook (WM Form #600). Wipe blade dry and store in a warm, dry place.

CAUTION! If the blade breaks during sawmill operation, the blade motor will be stopped automatically. Wait until both wheels have come to a complete stop before you open the blade housing covers.

CAUTION! Be sure to stop the blade when returning the saw head. This will not only prevent the blade from being pulled off and ruined by a wood sliver, but also will increase the life of the blade.

CAUTION! The sawmill's work-stand should be equipped with a 4 kg or bigger dry powder extinguisher.

CAUTION! If at any time you need to immediately stop the blade motor, press the emergency stop button located on the control box.

CAUTION! Always wear gloves when handling the blade. Never grab the blade with bare hands!

CAUTION! The sawmill should be operated with a sawdust extraction system only.



WARNING! Always wear eye, ear, respiration, and foot protection when operating or servicing the resaw.



WARNING! Always secure the saw head with a chain or a brace before adjusting the up/down chain. The saw head may fall, causing severe injury or death.

WARNING! Always secure the saw head with a chain or a brace before adjusting the saw head guide rollers. The cutting head may fall, causing severe injury or death.

CAUTION! Do not use chain lube. It causes sawdust buildup in chain links.

CAUTION! Due to variations in the vertical mast, the guide roller spacing may vary throughout the travel of the saw head. Check the guide roller spacing at the top and bottom ends of the mast only. Rollers adjusted too tight will cause premature up/down motor failure.



DANGER! Always disconnect and lock out power supply before performing any maintenance work, cleaning or servicing the sawmill!



IMPORTANT! No exchange with a different type of laser is permitted. No additional optical equipment shall be used.



DANGER! Visible and/or invisible laser radiation. Avoid eye or skin exposure to direct or scattered radiation.



IMPORTANT! Adjust the adjustable blade guard arm as close to the workpiece as practicable to clear the widest section of the log.

See Table 2-1 Pictographic safety decals placed on the WB2000 sawmill are shown in the table below.

TABLE 2-1



Decal View	Decal No.	Description
	096317	CAUTION! Read thoroughly the manual before operating the machine. Observe all safety instructions and rules when operating the sawmill.
	099220	CAUTION! Close all guards and covers before starting the sawmill.
	099219	Blade tension. Turning the bolt clockwise will increase the blade tension, and turning the bolt counterclockwise will decrease the tension.

TABLE 2-1

<p>099221</p>	<p>099221</p>	<p>CAUTION! Keep all other persons at a safe distance from work area when operating the machine.</p>
<p>098176</p>	<p>098176</p>	<p>CAUTION! Keep a safe distance from the debarker blade!</p>
<p>096316</p>	<p>096316</p>	<p>CAUTION! Do not open or close the electric box when the switch is not in the "0" position.</p>

TABLE 2-1

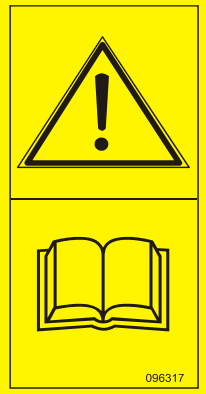

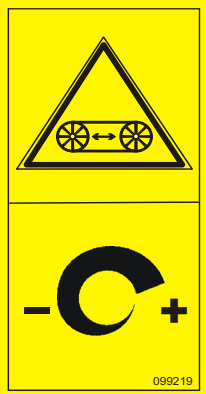

 <p>096319</p>	<p>096319</p>	<p>CAUTION! Disconnect power supply before opening the box.</p>																																	
 <p>099222</p>	<p>099222</p>	<p>CAUTION! Sawdust chute. Protect eyes!</p>																																	
 <p>096321</p>	<p>096321</p>	<p>Blade movement direction</p>																																	
 <table border="1"> <thead> <tr> <th rowspan="2">Type</th> <th colspan="3">  </th> <th rowspan="2">psi</th> <th rowspan="2">bar</th> </tr> <tr> <th>F(mm)</th> <th>E(mm)</th> <th>L(mm)</th> </tr> </thead> <tbody> <tr> <td>-</td> <td>1.27</td> <td>50 (2")</td> <td>6000</td> <td>950</td> <td>65</td> </tr> <tr> <td>3775</td> <td>1.14</td> <td>75 (3")</td> <td>6000</td> <td>950</td> <td>65</td> </tr> <tr> <td>5775</td> <td>1.27</td> <td>75 (3")</td> <td>6000</td> <td>1000</td> <td>70</td> </tr> <tr> <td>-</td> <td>1.2</td> <td>100(4")</td> <td>6000</td> <td>1100</td> <td>75</td> </tr> </tbody> </table> <p>568001</p>	Type				psi	bar	F(mm)	E(mm)	L(mm)	-	1.27	50 (2")	6000	950	65	3775	1.14	75 (3")	6000	950	65	5775	1.27	75 (3")	6000	1000	70	-	1.2	100(4")	6000	1100	75	<p>568001</p>	<p>Blade tension</p>
Type							psi	bar																											
	F(mm)	E(mm)	L(mm)																																
-	1.27	50 (2")	6000	950	65																														
3775	1.14	75 (3")	6000	950	65																														
5775	1.27	75 (3")	6000	1000	70																														
-	1.2	100(4")	6000	1100	75																														
 <p>099504</p>	<p>099504</p>	<p>Visible and/or invisible laser radiation. Avoid eye or skin exposure to direct or scattered radiation.</p>																																	

TABLE 2-1



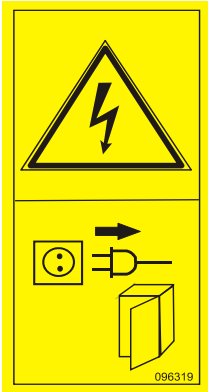
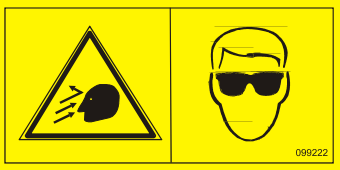
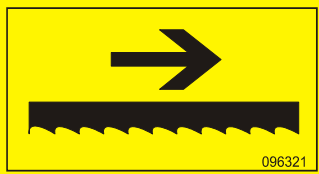
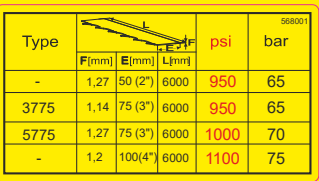



	<p>S12004G</p>	<p>CAUTION! Always wear safety goggles when operating the sawmill!</p>
	<p>S12005G</p>	<p>CAUTION! Always wear protective ear muffs when operating the sawmill!</p>
	<p>501465</p>	<p>CAUTION! Always wear safety boots when operating the sawmill!</p>
	<p>501467</p>	<p>Lubrication point</p>
 <p>P11789b</p>	<p>P11789</p>	<p>Aligning the blade on the wheels</p>

TABLE 2-1

	<p>P85070</p>	<p>CE sign</p>
	<p>099401</p>	<p>Russian safety certification</p>
	<p>S20097F</p>	<p>Motor rotation direction</p>

SECTION 3 SETUP & OPERATION

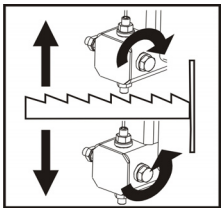
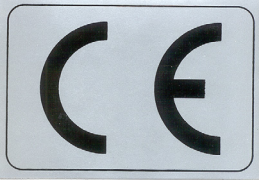
3.1. Sawmill Setup

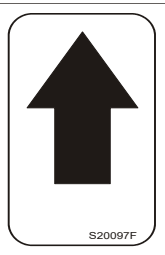

IMPORTANT! Before starting to use the sawmill you have to meet the following conditions:

- The sawmill should be operated with a sawdust extraction system only.
- The sawmill should be operated under roof only.
- The sawmill should be operated in temperature range from -15°C do 40° (5°F to 104°F) only.
- The illumination at the operator's position should be at least 300lx¹.
- The sawmill operator's position is shown below.
- A protective fence must be mounted according to the drawing below. Fence height - 1,8m.



IMPORTANT! In spite of necessity to mount the fence it is not possible to protect both sides of the sawmill from bystanders because of the cutting material loading and receiving. Keep all bystander persons at a safe distance from work area when operating the machine!

1. The light source can not cause stroboscopic effect.

See Figure 3-1

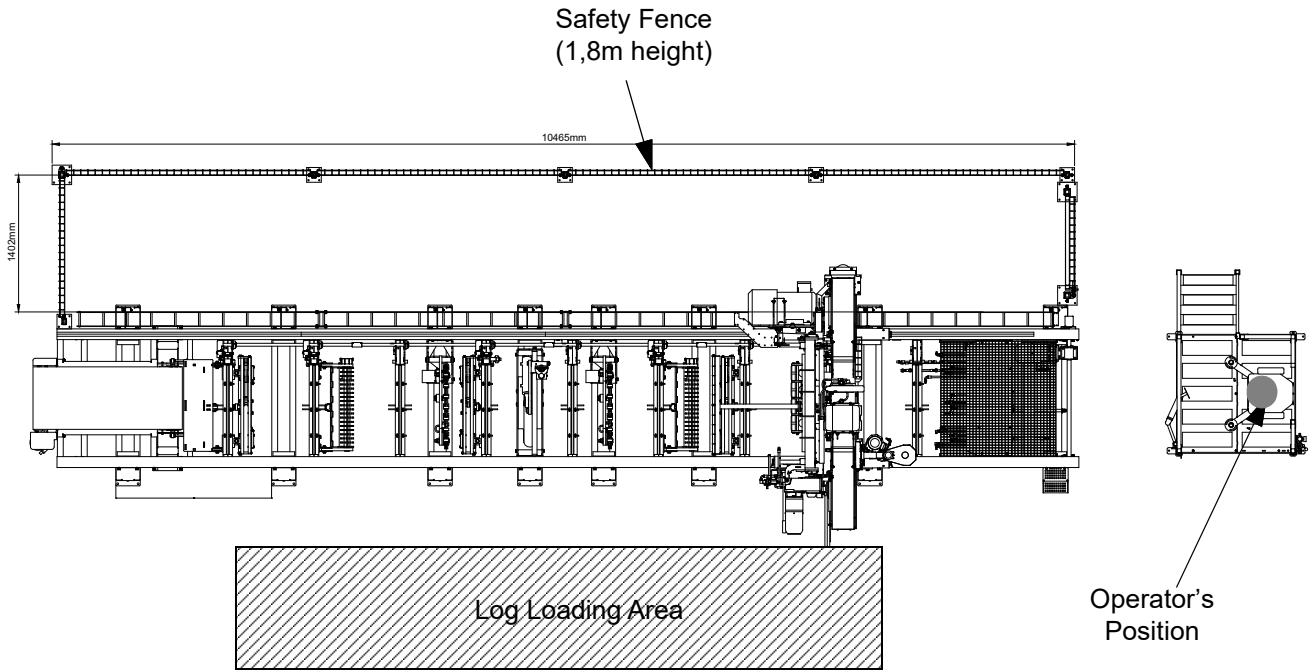

FIG. 3-1

See Table. 3-1.

- Have a qualified electrician install the power supply (according to EN 60204 Standard). The power supply must meet the specifications given in the table below.

3-Phase Volts	Fuse Disconnect	Suggested Wire Size
EH30, EC30 22 KW 400 VAC 460 VAC	50 A	16 mm ² to 15m in length 5 AWG to 49 ft in length
EH40, EC40 30 KW 400 VAC 460 VAC	105 A	16 mm ² to 15m in length 5 AWG to 49 ft in length
EH50, EC50 37 KW 400 VAC 460 VAC	108 A	16 mm ² to 15m in length 5 AWG to 49 ft in length

TABLE. 3-1



IMPORTANT! When starting the machine for the first time, check that main motor rotation direction is as indicated by the arrow located on the motor body. If the rotation direction is incorrect, invert the phases in the

phase inverter located in the power socket. Setting the phases in the phase inverter correctly will ensure correct rotation directions of all sawmill motors.



DANGER! A 30mA Ground Fault Interrupter (GFI) must be used.

Set up the sawmill on firm and level footing. Fasten the machine to the floor to prevent any movement. It is highly recommended that concrete foundation with 21mm (0.827") diameter anchor bolts be made under the bed. The concrete foundation should be rated to support 40 t/m² (8192 pound/foot).



WARNING! Set up the resaw on firm and level ground. The machine must be fastened to the floor. Failure to do so may cause the sawhead to tip, resulting in serious injury or death.

The machine can be lifted with a forklift or a winch only. The forklift must be rated for at least 4 t (8818 lb.).

3.2 Control Overview

See **Figure 3-2** The control box includes controls to start and stop the machine. The operator interface also contains the touch screen used to set up the machine and diagnose problems.

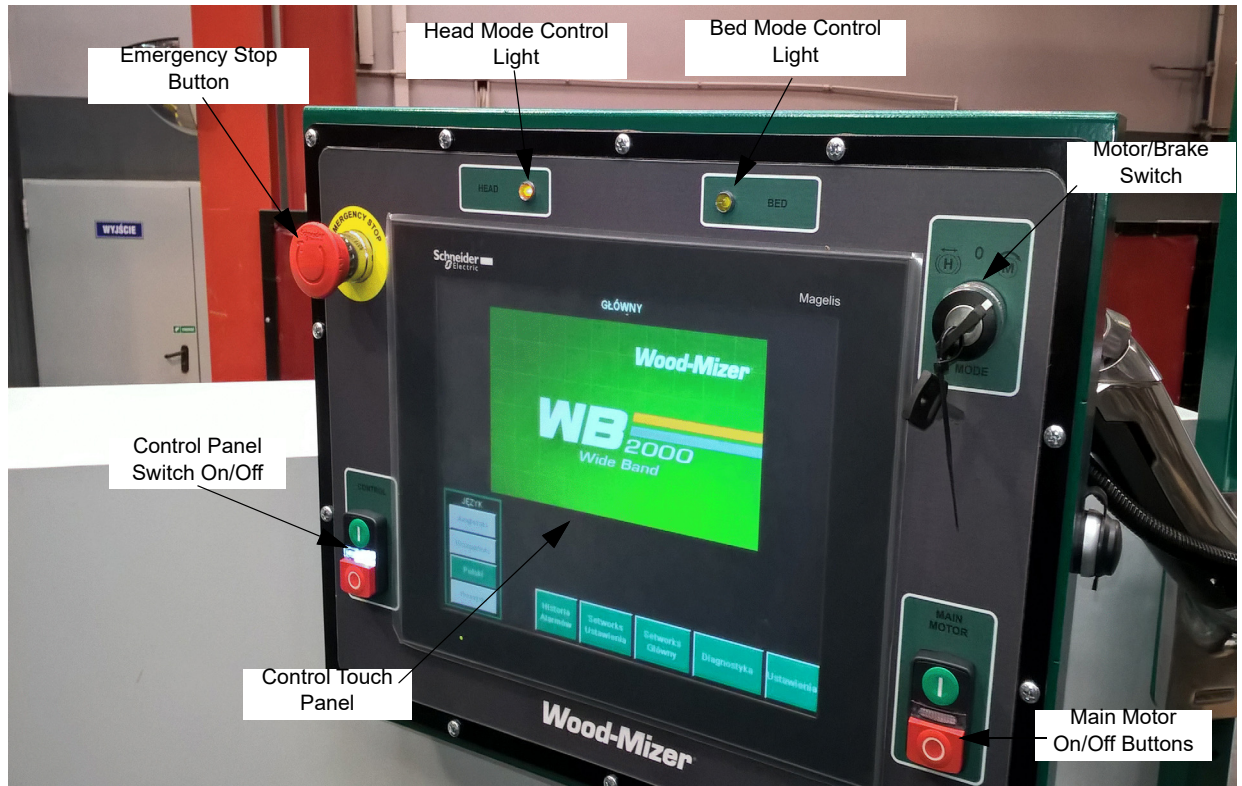

FIG. 3-2 CONTROL PANEL

Control Panel

1. Emergency Stop



Push the emergency stop button to stop the machine. Turn the emergency stop clockwise to release the stop. The machine will not restart until the emergency stop is released.

2. HEAD/BED mode indicator lamps.

Indicates operation mode of the control panel.

3. Motor/Brake Key Switch

The key switch has three positions:

- “0” position - all electrical circuits are off,
-  position - all electrical circuits are on,
-  position - releases the main motor disk brake, it is possible to spin the blade wheels to track the blade.

4. Control Panel Power Switch

Turns on and off power to the control panel.

5. Control Touch Panel

The touch screen is used to setup how the mill functions and controls the networks. Upon initial power-up, the screen will display the Home Screen..

6. Main motor START/STOP buttons

Turns on and off the main motor.



To start the blade motor, turn the key switch to the  position. Then press the START button. To stop the blade motor, press the STOP switch.

3.3 Joystick Control Overview

See Figure 3-3The joysticks located at the operator seat control all of the sawmill functions. Each joystick can be moved forward, backward, left and right to perform various functions. Each joystick also has a thumbstick, three front buttons and a rear switch to perform additional functions.

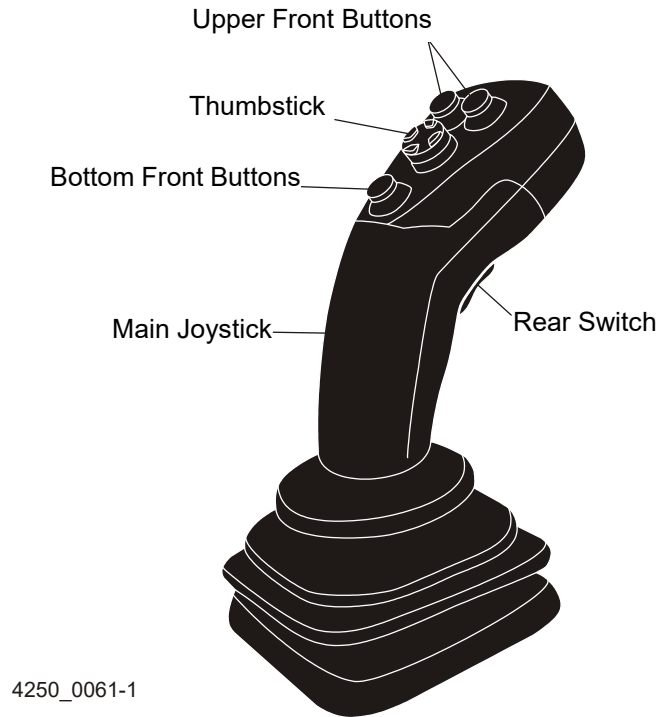

FIG. 3-3

The machine comes with three configurations of the joystick controls: Default, User 1, and User 2. If the operator prefers to have some functions in different locations, he can move them around in one of the user modes and save the layout. All of the reference in this section will be related to the default layout.

To toggle between head and bed functions, press the rear switch of the left joystick. The MODE light on the head distribution box will indicate if the controls are in bed mode or head mode. There is also indication of the mode the controls are in on the touch screen, if the touch screen displays one of the networks screens.

See Figure 3-4 In HEAD mode, push the left joystick forward to lower the saw head. The further the joystick is pushed, the faster the head moves down. Pull the joystick back to raise the saw head. The further the joystick is pulled, the faster the head moves up.

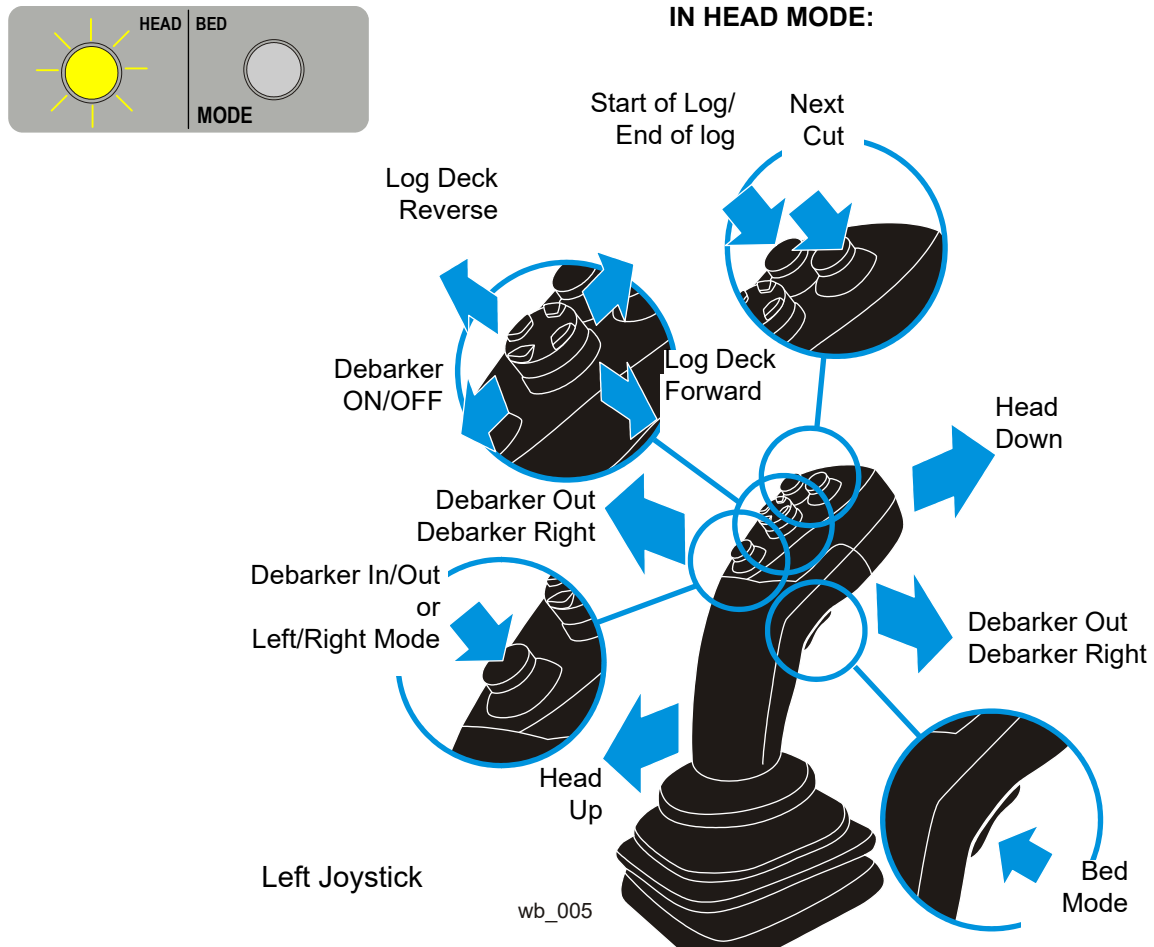

FIG. 3-4

Press the top left head button to set either the Start of Log position or the End of Log position. Press the top right head button to toggle on/off Next Cut. Press the bottom head button to start the debarker operation. Press the rear switch to change to Bed Mode. Press the thumbstick left to reverse the log deck, right to move the log deck forward. Press the thumbstick up to increase the Cant Count in Pattern Mode, down to decrease the count.

See Figure 3-5In HEAD mode, push the right joystick forward to make the head travel backwards. The further the joystick is pushed, the faster the head moves backward. Pull the joystick back to make the head travel forward. The further the joystick is pulled, the faster the head travels forward.

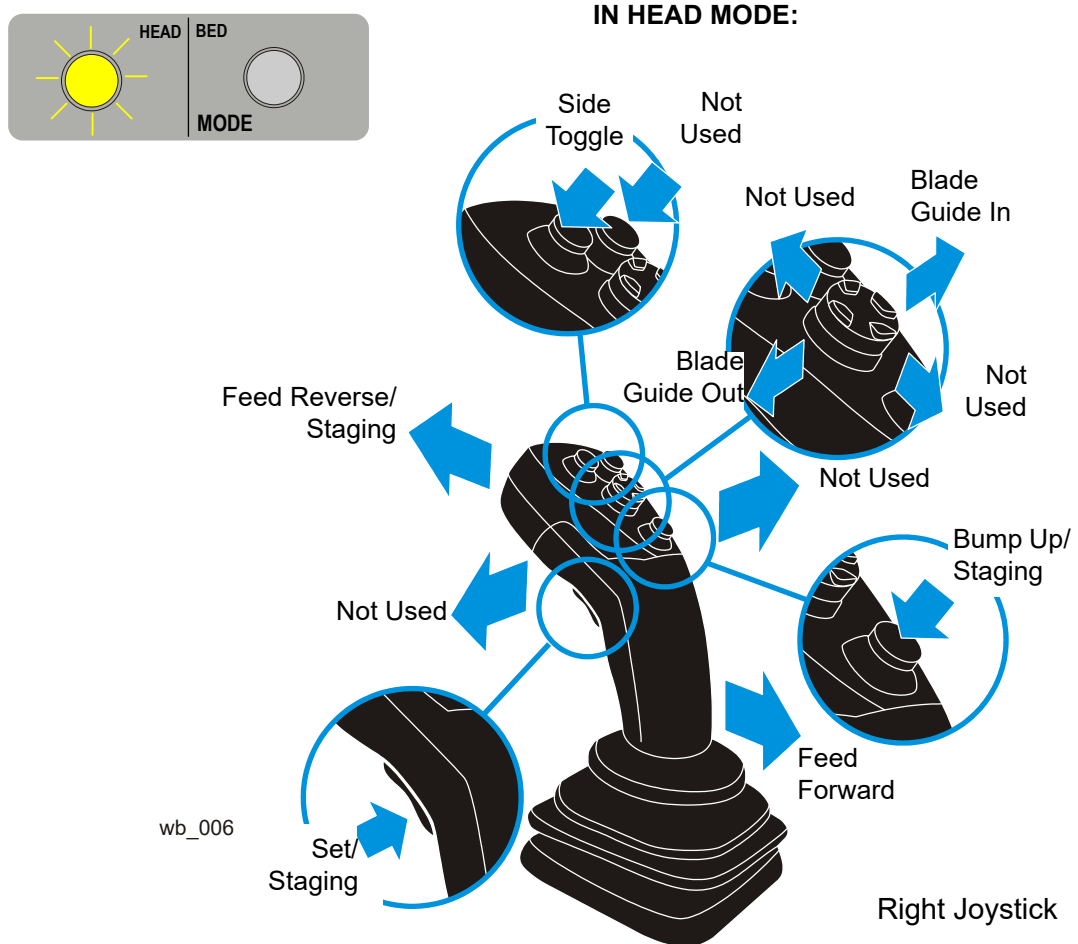

FIG. 3-5

Press the top left head button to toggle between sides in Networks. Press the bottom head button to initiate a bump up function. Press the rear switch to initiate a set function. Press the thumbstick left to move the blade guide out, and press it right to move the blade guide in. While moving the head backward pressing both the set and bump up functions together initiates a move to the staging position.

3 Setup & Operation

Joystick Control Overview

See Figure 3-6 In BED mode, push the left joystick forward to lower the clamp. The further the joystick is pushed, the faster the clamp moves down. Pull the joystick backward to raise the clamp. The further the joystick is pulled, the faster the clamp moves up. Push the joystick left to move the clamp out. The further the joystick is pushed, the faster the clamp moves out. Push the joystick right to move the clamp in. The further the joystick is pushed, the faster the clamp moves in.

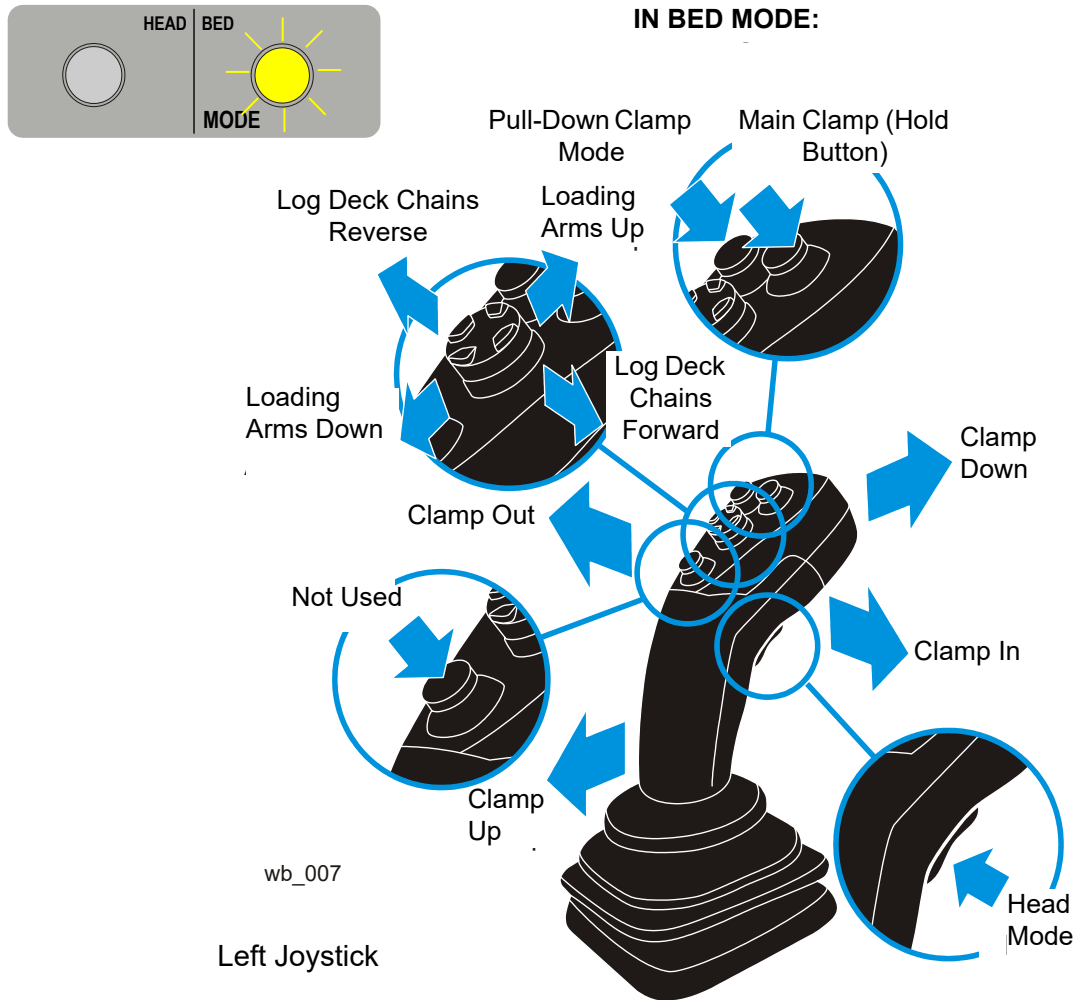

FIG. 3-6

Press the thumbstick forward to raise the loading arms, press it down to lower the loading arms. Press the thumbstick left to make the log deck chains move backward. Press the thumbstick right to make the log deck chains move forward. Press the rear switch to switch to HEAD mode.

See Figure 3-7In BED mode, push the right joystick forward lower the side supports. The further the joystick is pushed, the faster the side support move down. Pull the joystick backward to raise the side supports. The further the joystick is pulled, the faster the side supports move up. Pull the joystick left to lower the chain turners. The further the joystick is pulled, the faster the chain turners move down. Push the joystick right to raise the chain turners. The further the joystick is pushed, the faster the chain turners move up.

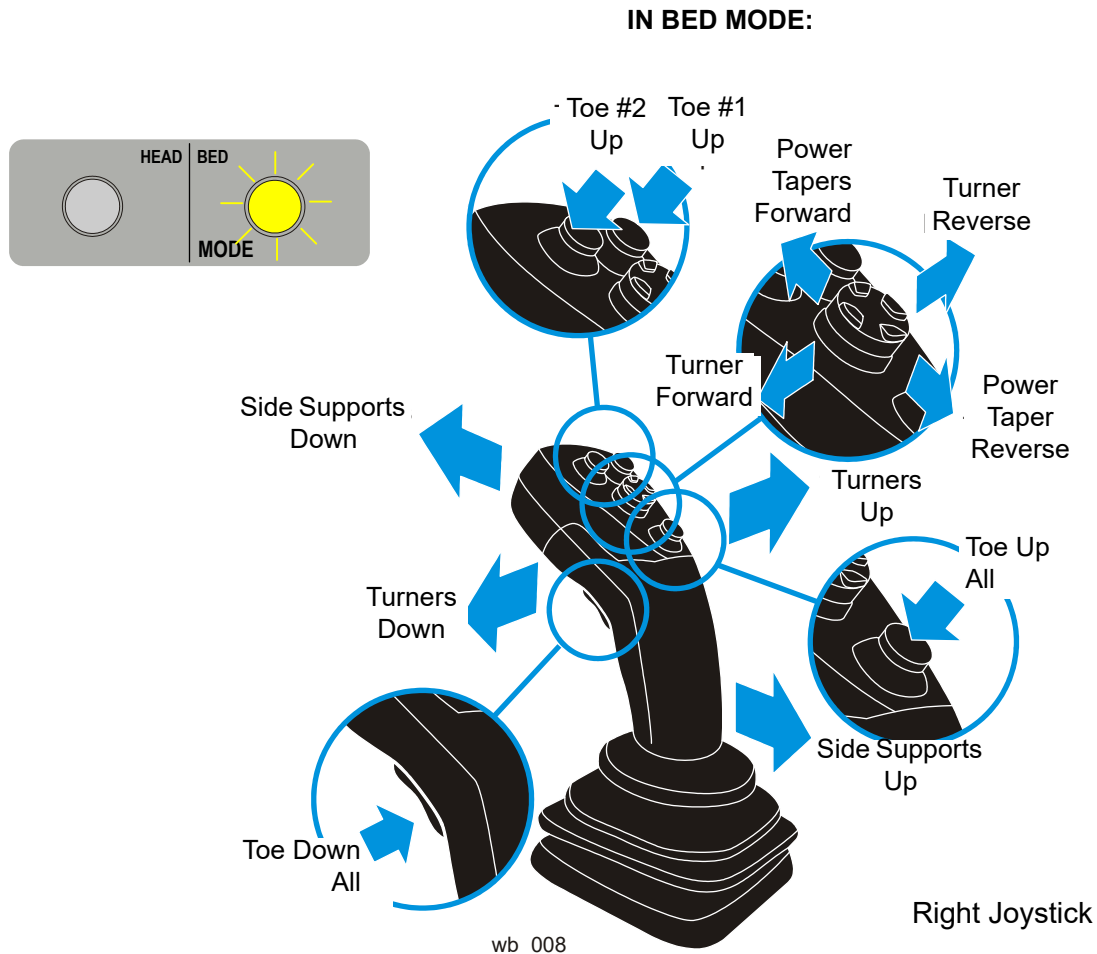

FIG. 3-7

Press the top left head button to raise Toe #2. Press the top right head button to raise Toe #1. Press the bottom head button to raise all the Toe Boards. Press the rear switch to lower all the Toe Boards. Press the thumbstick forward to turn the power taper rollers forward and press it down to move the power taper rollers backward. Press the thumbstick left to rotate the change turners forward and press it right to rotate the change turners backward.

3.4 Programming the Control

3.4.1 System Setup

From the Main Screen, push the Setup button.

See Figure 3-8

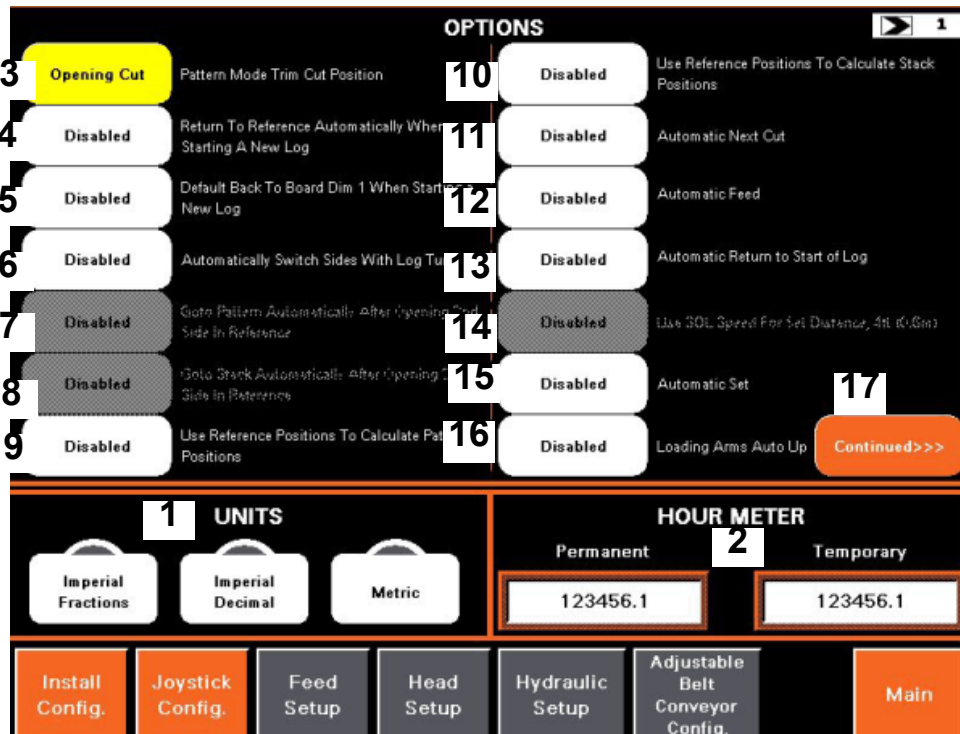

FIG. 3-8

3.4.2 Units

There are three selections for units (1): Imperial Fractions, Imperial Decimals, and Metric. The active unit has a green indicator. To change units, press the desired button and the indicator for that unit will turn on.

3.4.3 Hour Meter

There is a permanent hour meter (2) that is not resettable, and a temporary hour meter that can be reset by pressing the numeric display. **NOTE:** If the PLC is ever replaced, the permanent hour meter will start back over at 0.

3.4.4 Options

There are several optional functions built into the mill to help automate some of the steps for sawing a log. These steps were developed around the most common cutting method.

Typically the method followed is to open two sides in reference mode. Switch to pattern mode and cut down to the desired number of cants with the dimensions selected.

(3) Pattern Mode Trim Cut Position - in pattern mode you can select where to take the trim but, either on the opening cut or before the first cant/last board.

(4) Return To Reference Automatically When Starting A New Log - When enabled the touch screen will automatically switch back to Reference mode each time a new log is started. There are two ways to signal the start of a new log; performing a Staging function, or lowering the loading arms all the way.

(5) Default Back To Board Dim 1 When Starting A New Log - When enabled the board size in the first board size button, from left to right, will be selected each time a new log is started. There are two ways to signal the start of a new log; performing a Staging function, or lowering the loading arms all the way.

(6) Automatically Switch Sides With Log Turns - When enabled the machine will switch sides, i.e. Reference 1 to Reference 2, when the log is unclamped and the any of the four chain turner functions are activated; Up/Down or Forward/Reverse. The machine will not keep changing sides each time one of these functions is activated. There must be a cut taken on the side switched to before the machine will switch again.

(7) Go to Pattern Automatically After Opening 2nd Side In Reference - When enabled the touch screen will automatically switch to Pattern mode after a cut has been taken in Reference 2 and a log turn is sensed. This option is not available unless the option to Automatically Switch Sides With Log Turns is enabled.

(8) Go to Stack Automatically After Opening 2nd Side In Reference - When enabled the touch screen will automatically switch to Stack mode after a cut has been taken in Reference 2 and a log turn is sensed. This option is not available unless the option to Automatically Switch Sides With Log Turns is enabled.

(9) Use Reference Position To Calculate Pattern Positions - When enabled, and the trim cut position is set to opening cut, the last cut taken in Reference 1 will be used as the position to reference for the position of the head in pattern mode for calculating the pattern based off the cant size selected, number of cants, and board size selected. This prevents having to search for best position for possible opening cut. When enabled, and the trim cut position is set to first cant/last board, the last cut taken in Reference 1 will be used as the last but taken in Pattern 1 and just set to the next board size. Reference 2 last cut position will be used for Pattern 2.

(10) Use Reference Position To Calculate Stack Positions - When enabled the last cut taken in Reference 1 will be used as the position to reference for the position of the head in stack mode for calculating the starting position in the stack. Reference 2 last cut position will be used for Stack 2.

(11) Automatic Next Cut - When enabled Next Cut will automatically turn on when taking the opening cut on all four sides when the machine senses a cut is active based on the blade motor power engage threshold setting.

(12) Automatic Feed - When enabled the machine will automatically control the feed speed based on the two settings, maximum speed and maximum power, set on the "Dashboard". If the maximum speed is reached before the maximum power the feed will not increase anymore, otherwise it will continue to

3 Setup & Operation

Options

increase until it reaches the maximum power setting. The operator still has control over the speed, the automatic feed will just prevent them from feeding too fast, per the maximum power setting. If the operator backs off on the joystick the machine will choose which ever speed is lower and use that, either the Automatic Feed or the Joystick.

(13) Automatic Return to Start of Log - When enabled after the head has exited the cut, performed a bump up, and started to move backwards this function will take control of the feed and automatically return to the position set for Start of the Log (**SOL**). The operator does not need to worry about letting off the joystick in time to stop the head before it travels too far past the log, the machine will stop it automatically, just keep the joystick pressed all the way forward until the head comes to a complete stop.

(14) Use SOL Speed For Set Distance, 2ft (0.6m) - When enabled the start of log speed set on the "Dashboard" will only be used for a distance of 2ft (0.6m) from the point where it was set. Once the head has moved past this point, the speed is completely controller by the position of the joystick.

(15) Automatic Set - When enabled the head will automatically set to the next cut when the head has returned to the Start of the Log position.

(16) Loading arms auto up - When enabled, loading arms are lifted automatically after pressing the appropriate button on the joystick.

(17) Use this button to go the second page of options.

See Figure 3-9 The second page of options is shown below.

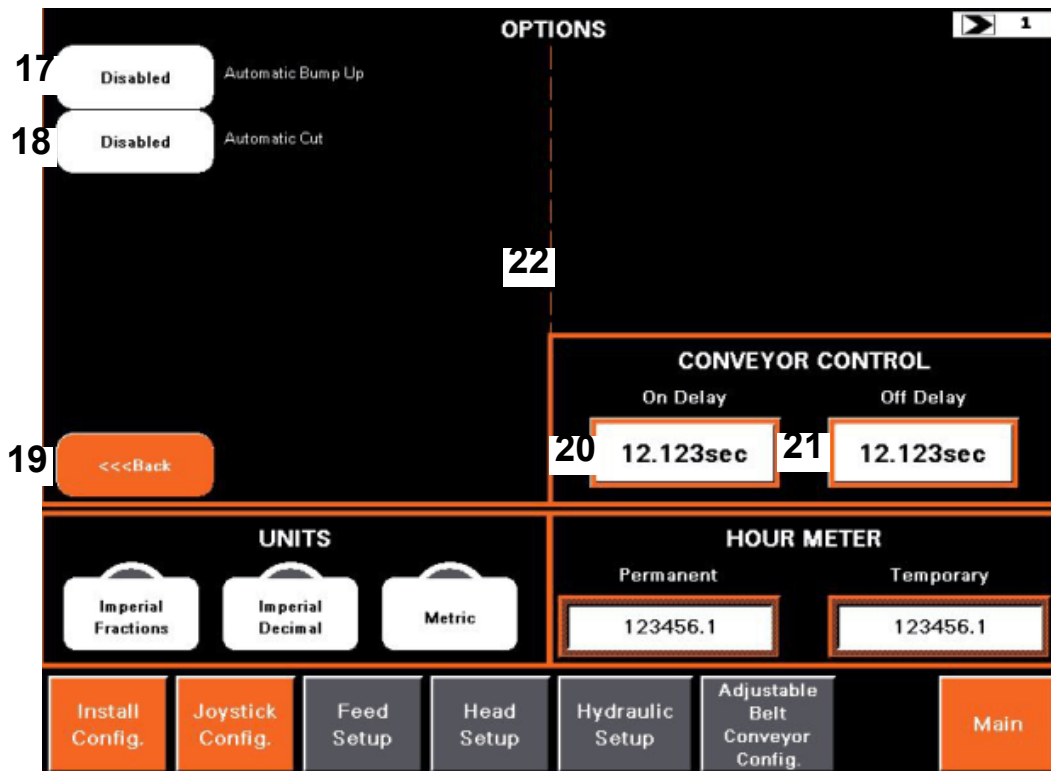

FIG. 3-9

(17) Automatic Bump Up - When enabled the saw head will automatically bump up after the saw head has exited to cut and passed the End of Log position.

(18) Automatic Cut - When enabled the machine can run the cutting process automatically when the operator holds down the foot pedal. To initiate this the operator must have the Start of Log and End of Log positions set, Next Cut on, then hold down the foot pedal when either at the Start of Log or End of Log positions. The head will automatically cut using the Automatic Feed, Bump Up, Return, and Set, all on its own, and continue this process until the foot pedal is released.

(19) Use this button to go back to the first page of options.

(20) This timer sets how long the feed must be in reverse before the conveyor will start.

(21) This timer sets how long the conveyor will keep running after the feed has stopped moving in reverse.

(22) Use this button to separate operation of the side support and the turners. When disabled, the side supports and turners work together - when raising the turners, first the side supports are moving up. When enabled, it is possible to control the turner independently of the side supports. It is recommended that this option be set to: *Disabled*.

3.4.5 Joystick Configuration

See Figure 3-10 The machine is equipped with a programmable joystick configuration. There is a default Joystick Configuration and two User Defined Configurations. During the installation of the machine it may be necessary to configure some of the parameters of the joysticks.

From the System Setup Screen, push the Joystick Config. button to go to the Joystick Configuration screen.

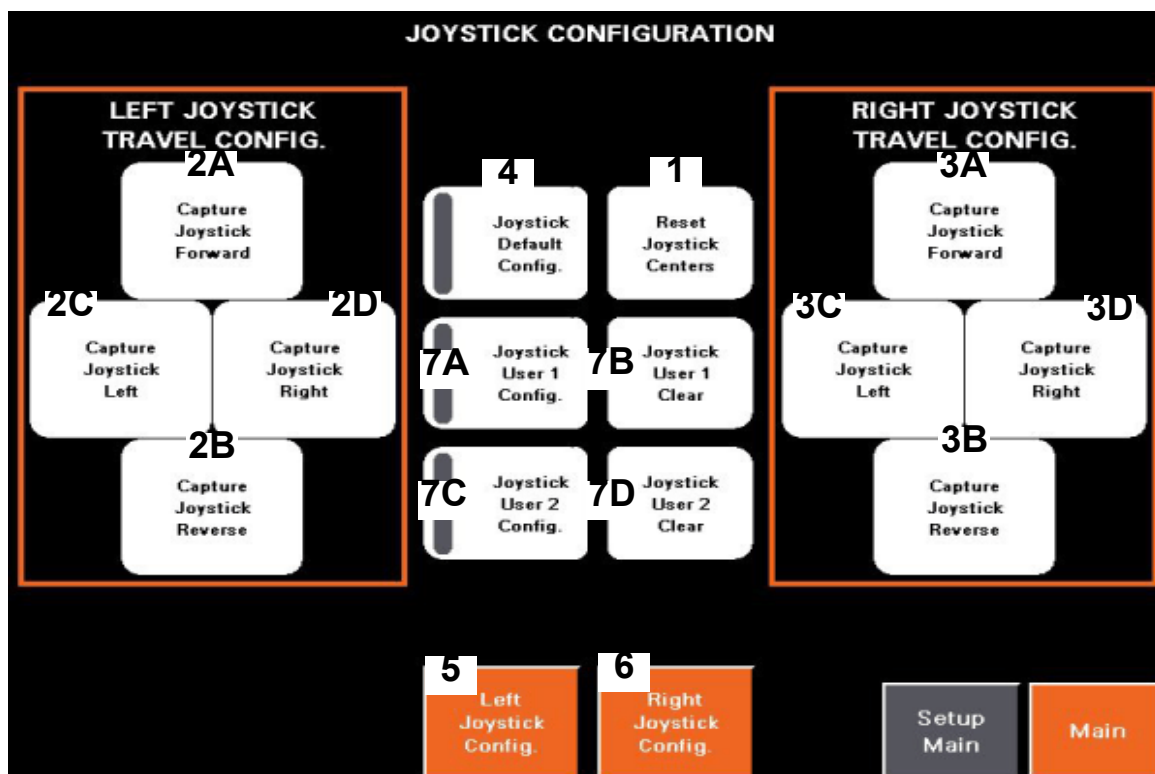

FIG. 3-10

(1) Reset Joystick Centers - During the very first power up of a mill, replacement of a joystick, or replacement of the PLC, the centers of the joysticks will have to be set. If the machine knows the centers need set it will be flashing and there will be an active “Joystick Configuration” error. Every joystick varies a little to its exact center point so it is critical to the operation of the machine that the centers be adjusted to the joysticks. Before pressing the button make sure the joysticks are in their relaxed position with nothing pushing them in any direction. When the centers are captured the PLC also configures a dead band area around the centers that has to be exceeded to make the joystick control any motion.

(2) Left Joystick Travel Configuration - Under any of the three conditions explained for the joystick centers the travel configuration will also have to be set. These buttons also flash when the machine knows they need set.

- **(2A) Capture Joystick Forward** - To capture the joystick forward value, press the joystick all the way forward. While maintaining the joystick all the way forward, press this button.

- **(2B) Capture Joystick Reverse** - To capture the joystick reverse value, pull the joystick all the way backward. While maintaining the joystick all the way backward, press this button.
- **(2C) Capture Joystick Left** - To capture the joystick left value press the joystick all the way left. While maintaining the joystick all the way left, press this button.
- **(2D) Capture Joystick Right** - To capture the joystick right value pull the joystick all the way right. While maintaining the joystick all the way right, press this button.

(3) Right Joystick Travel Configuration - Under any of the three conditions explained for the joystick centers. The travel configuration will also have to be set. These buttons also flash when the machine knows they need set.

- **(3A) Capture Joystick Forward** - To capture the joystick forward value, press the joystick all the way forward. While maintaining the joystick all the way forward, press this button.
- **(3B) Capture Joystick Reverse** - To capture the joystick reverse value, pull the joystick all the way backward. While maintaining the joystick all the way backward, press this button.
- **(3C) Capture Joystick Left** - To capture the joystick left value, pull the joystick all the way left. While maintaining the joystick all the way left, press this button.
- **(3D) Capture Joystick Right** - To capture the joystick right value press the joystick all the way right. While maintaining the joystick all the way right, press this button.

(4) Joystick Default Config. - This button selects the default layout of all the joystick functions. When the default configuration is active, the indicator on the button will be green.

(5) Left Joystick Config. - This button takes you to a page where you can view the joystick configuration.

(6) Right Joystick Config. - This button takes you to a page where you can view the joystick configuration.

(7) User Defined Joystick Configurations - These buttons control the user defined joystick configurations.

- **(7A) Joystick User 1 Config.** - This button selects the user 1 configuration. When the user 1 configuration is active the indicator on the button will be green.
- **(7B) Joystick User 1 Clear** - This button clears the user 1 configuration from memory.
- **(7C) Joystick User 2 Config.** - This button selects the user 2 configuration. When the user 2 configuration is active the indicator on the button will be green.
- **(7D) Joystick User 2 Clear** - This button clears the user 2 configuration from memory.

3 Setup & Operation

Joystick Configuration

User Defined Joystick Configurations

This section will explain how to define a user configuration for the joysticks and save it. In this section the User 1 configuration will be referenced. Setting for the User 2 configuration is the same - just substitute the User 2 buttons for the User 1 in the instructions below.

1. Press the “Joystick User 1 Config.” button (7A). The green indicator on the button should come on.
2. Press the “Left Joystick Config.” button (5) to begin setting the functions.

See Figure 3-11

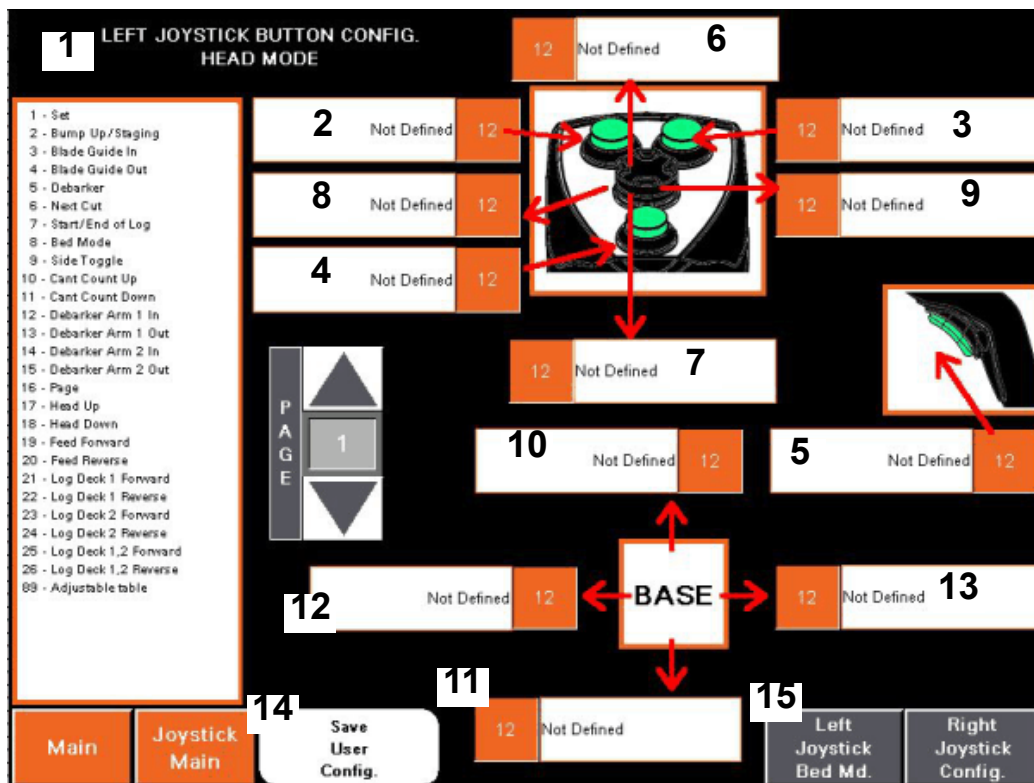

FIG. 3-11

3. (1) This is the legend that lists all the available head mode functions and their number that is used to set that function to a specific joystick function.

4. **(2-13)** To assign a function to any joystick function, press the gray button (numeric entry), with a red arrow pointing to the function you want to program.
 - Enter the value of the function you want to assign and press enter.
 - Now that number will be displayed in the gray box and the function will be displayed in the message display next to the grey box.
 - Do this for all functions. There doesn't have to be a function assigned to each joystick function.
 - Functions **(10-13)** have to be assigned to the base of the joysticks. Between the two joysticks you have 8 locations for these functions. When you assign function 10, Head Up, to a base location, function 11, Head Down, will automatically be assigned to the opposite joystick function on the same joystick. These functions have to be put together on the same joystick. The same goes for functions 12 and 13, for the feed. These four functions are not allowed to be used on the discrete buttons of the joysticks and the touch screen will not allow you to enter them into those spots.
5. **(14)** When you are finished setting up the joystick for head mode, you can save the configuration by pressing the "Save User Config." button.
6. **(15)** Now you are ready to set up bed mode for this joystick. Press the "Left Joystick Bed Md." button.

3 Setup & Operation

Joystick Configuration

See Figure 3-12 The BED MODE screen for the Left Joystick Button Configuration is shown below.

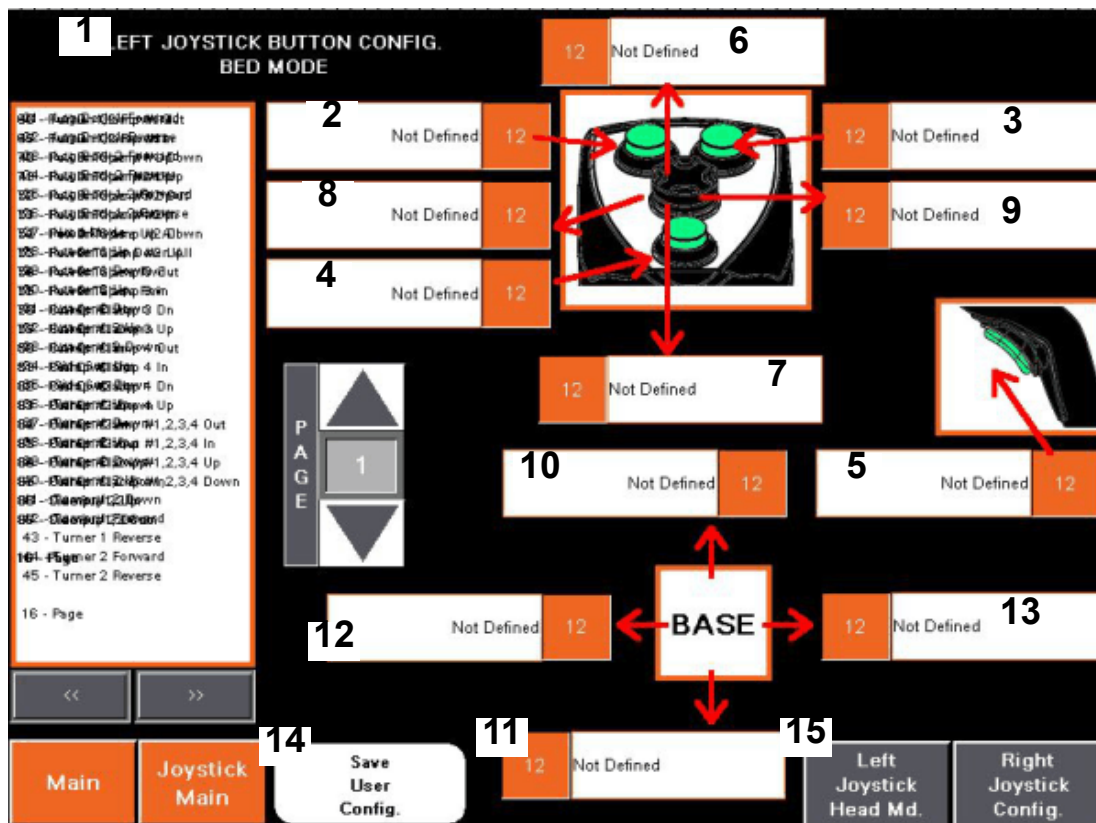

FIG. 3-12

7. (1) This is the legend that lists all the available head mode functions and their number that is used to set that function to a specific joystick function.
8. (2-13) All the functions are set just as in head mode referenced in step 4.
9. (14) When you are finished setting up the joystick for head mode, you can save the configuration by pressing the “Save User Config.” button.
10. The left joystick configuration is finished. Follow the same procedure for the right joystick. Press the “Right Joystick Config.” button on the “Joystick Configuration” to enter the right joystick configuration instead.

3.4.6 Feed Setup

The Feed Setup screen is where the Return To Start Of Log function can be tuned and the position of feed calibrated. You can also reference feed speed from this screen.

See Figure 3-13

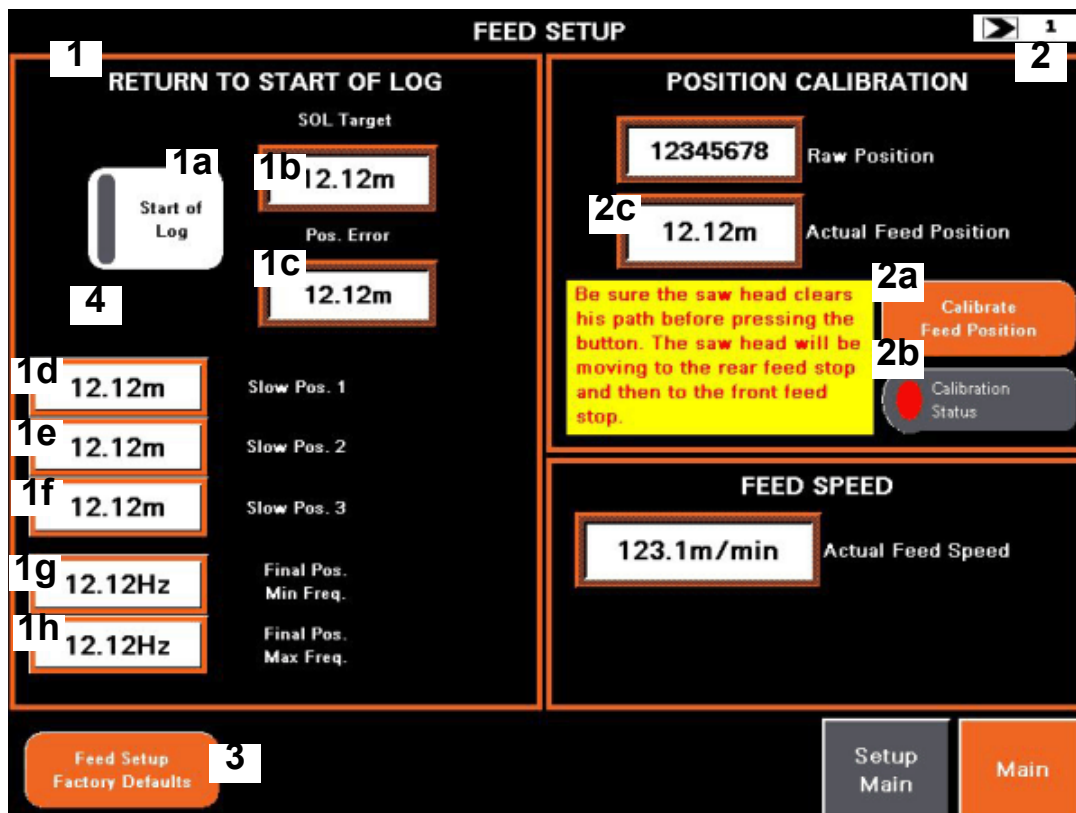

FIG. 3-13

Return To Start Of Log

This section of the Feed Setup is used to tune the Return To Start of Log function. When tuning it you are trying to get the “Pos. Error” to be as small as possible, meaning that you are as close as possible to the target you are trying to reach.

There are three positions captured for the Start of Log Position; Actual Start of Log Position, Offset, and Target. The actual position is the one captured by pressing the button either on the touch screen or joystick. This position is used to signal the machine that the head has moved into a safe position behind the log and it is okay to perform a set. The offset position is the position the feed will stop at when feeding forward until it is in position for the next cut. The target is the position the feed system is shooting for during the return. During the return, after the head has passed the Start of Log Position a set will initiate. The feed will continue returning to the Target and then stop. Now you can feed forward, the head may stop at the Offset position, if the head is not in position for the next cut. If the head is in position, there will not be a stop, it will continue to feed forward and start the cut.

Tuning Return To Start Of Log

1. Move the head to where you want to set “Start of Log” and press the “Start of Log button (1A). The indicator will turn green to show that the position has been set, and the position will display under “SOL Target”.
2. Now run the feed about 12 ft. from that position.
3. Push the Right joystick forward and maintain it until the head comes to a complete stop.
4. Check the “Pos. Error”. If it is within a couple inches from the target leave it alone, the tuning is fine. The control for returning to start of log is not designed to be extremely accurate, because it is not necessary, so a couple inch tolerance is fine. Process is complete. If the “Pos. Error” is too large then continue to step 5.
5. You can modify the Slow Positions and Final Pos. frequencies, until you achieve the accuracy wanted.
 - **Slow Pos. 1 (1D)** - Default = 2.75. This is the position, distance from Start of Log Target, at which the feed drive will slow to 60Hz. Prior to reaching this point the feed will travel in reverse at maximum speed.
 - **Slow Pos. 2 (1E)** - Default = 1.5. This is the position, distance from Start of Log Target, at which the feed drive will slow to the “Final Pos. Max Freq.” **(1H)**.
 - **Slow Pos. 3 (1F)** - Default = 0.75. This is the position, distance from Start of Log Target, at which the feed drive will ramp from the “Final Pos. Max Freq.” **(1H)**, to the “Final Pos. Min Freq.” **(1G)**. The deceleration of the drive is proportional to the distance from “Slow Pos. 3” **(1F)** to “SOL Target” **(1B)**. The drive will begin at the frequency in “Final Pos. Max Freq.” **(1H)** at “Slow Pos. 3” **(1F)** and do a linear slope to the frequency in “Final Pos. Min Freq.” **(1G)** at “SOL Target” **(1B)**.
 - **Final Pos. Min Freq.** - Default = 1.
 - **Final Pos. Max Freq.** - Default = 35.

Position Calibration

This mill uses an encoder to track feed position for different locations (e.g. Start of Log Position and End of Log Position). With the ability to have these values more functions can be automated during the sawing cycle.

Position Calibration Procedure

If the machine needs to be calibrated, the HMI will automatically switch to the “Feed Setup” screen after control power is turned on. The only time this is not the first screen gone to after a power cycle is when there is a Joystick Configuration fault and the Centers of each joystick need to be reset and the furthest travel positions need to be captured. Usually this will only happen during the initial install of the machine, and never again unless the PLC gets replaced. If the “Feed Setup” screen is already active then proceed to step 3.

1. From the “Main” screen press the “Setup” button.
2. On the “Setup” screen press the “Feed Setup” button.
3. At the top right of the “Feed Setup” screen is the “Position Calibration” section **(2)**. If the calibration is required then the “Calibration Status” **(2B)** will be RED, if you are just re-calibrating then it is probably GREEN.
4. Make sure there are no obstructions in the path of the saw head. The head will travel all the way to the reverse hard stop.
5. Press the “Calibrate Feed Position” **(2A)** button.
6. The head will start slowly traveling to the reverse hard stop. To calibrate the feed position the head presses against the hard stop until there is a spike in motor current on the feed motor. At that point that position is called 1' 0”, and the “Actual Feed Position” **(2C)** should have a value around 1.0ft., the value sometimes floats above this because when the feed drive release pressure the rubber stop pushes the head back away from it. The “Calibration Status” **(2B)** will turn green when the process is complete.
7. Press the “Feed Setup Factory Defaults” **(3)** to restore factory settings for the feed setup.

3 Setup & Operation

Head Setup

3.4.7 Head Setup

The Head Setup screen is where the Head Position can be tuned and the position of head calibrated.

See Figure 3-14 The Head Setup screen is shown below.

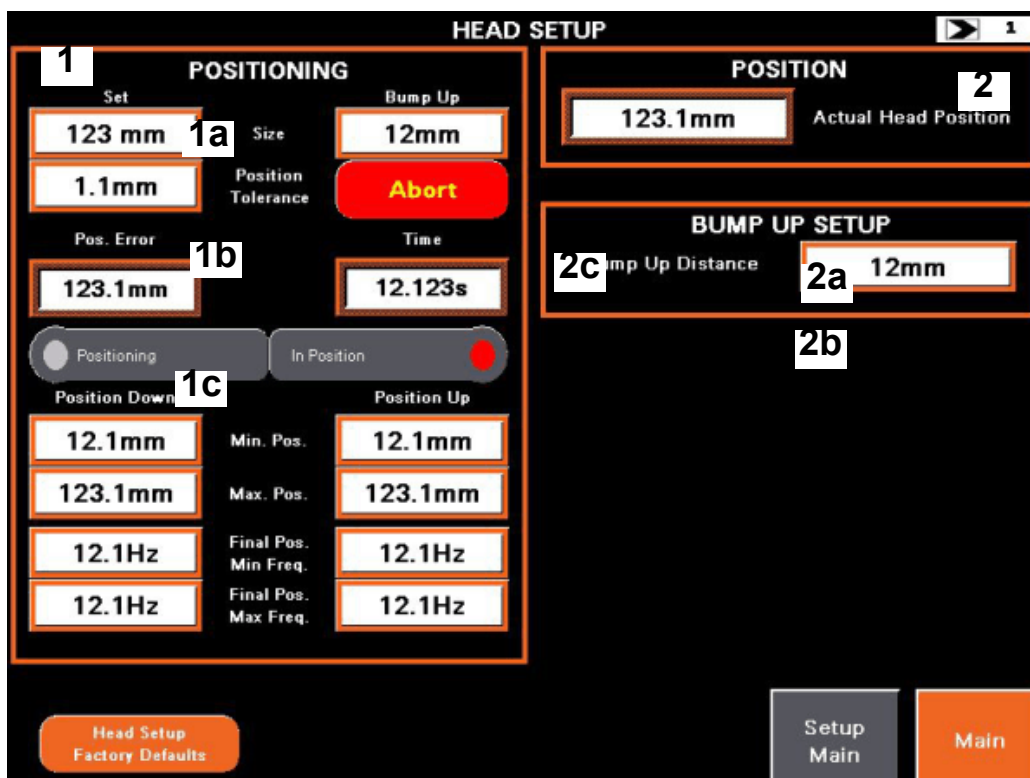

FIG. 3-14

Servo Setup

These settings control the speed the servo does Sets and Bump Ups.

- Velocity for sets.
- Velocity for bump ups.
- Bump up distance.

Position Calibration

The servo has an internal encoder for tracking head position.

Position Calibration Procedure

If the machine needs calibrated, the HMI will automatically switch to the “Head Setup” screen after con-

trol power is turned on. If the “Head Setup” screen is already active then proceed to Step 3.

1. From the “Main” screen press the “Setup” button.
2. On the “Setup” screen press the “Head Setup” button.
3. At the top right of the “Head Setup” screen is the “Position Calibration” section. If the calibration is required then the “Calibration Status” will be RED, if you are just re-calibrating then it is probably GREEN.
4. Position the head over a bed rail and measure from a down set tooth to the bed rail.
 - Enter this value in the “Calibration Position” numeric entry box.
5. Press the “Calibrate Head Position” button.
6. Calibration complete.

Hydraulic Setup

The hydraulic power unit on this machine is equipped with a proportional valve on the supply line to all the valve packs. Since only 8 functions can be assigned to the joystick bases for full proportional control, a setup screen for all functions has been added so that a set-point for flow to each function can be set from 5-100%. If multiple functions are selected with set-points then that proportional valve will open fully to give sufficient flow. If a proportional function is used with a discrete function the proportional valve will use the proportional signal. If multiple proportional functions are activated then the proportional valve will open fully to give sufficient flow.

See Figure 3-15 The Hydraulic Functions Speeds screen is shown below.



FIG. 3-15

See Figure 3-16

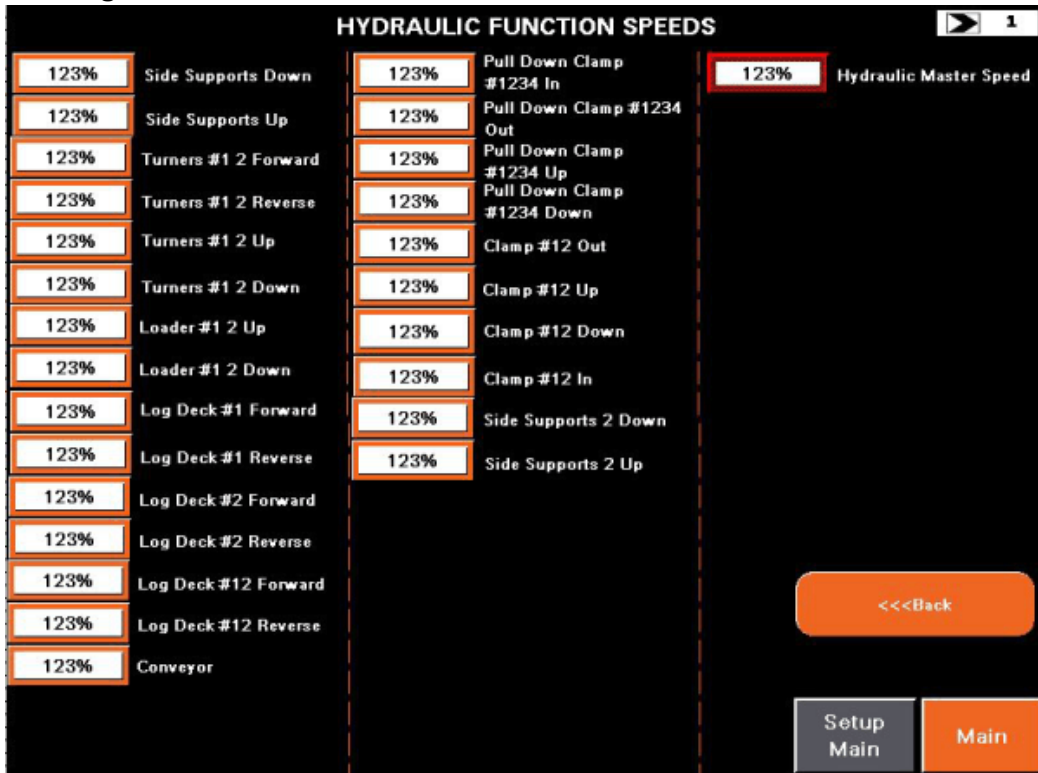

FIG. 3-16

Changing Hydraulic Set-Points

(1) To modify one of the hydraulic set-points, just press the number display for the function you want to change, then enter the new value and press Enter.

3 Setup & Operation

Setworks Setup

3.4.8 Setworks Setup

From the Home screen, touch the Setworks Setup button.

See Figure 3-17 There are six Board Size buttons used in Reference and Pattern modes. There are also eight Cant Size buttons used in Reference and Pattern modes. Their values are always displayed on the touch screen when in these modes.

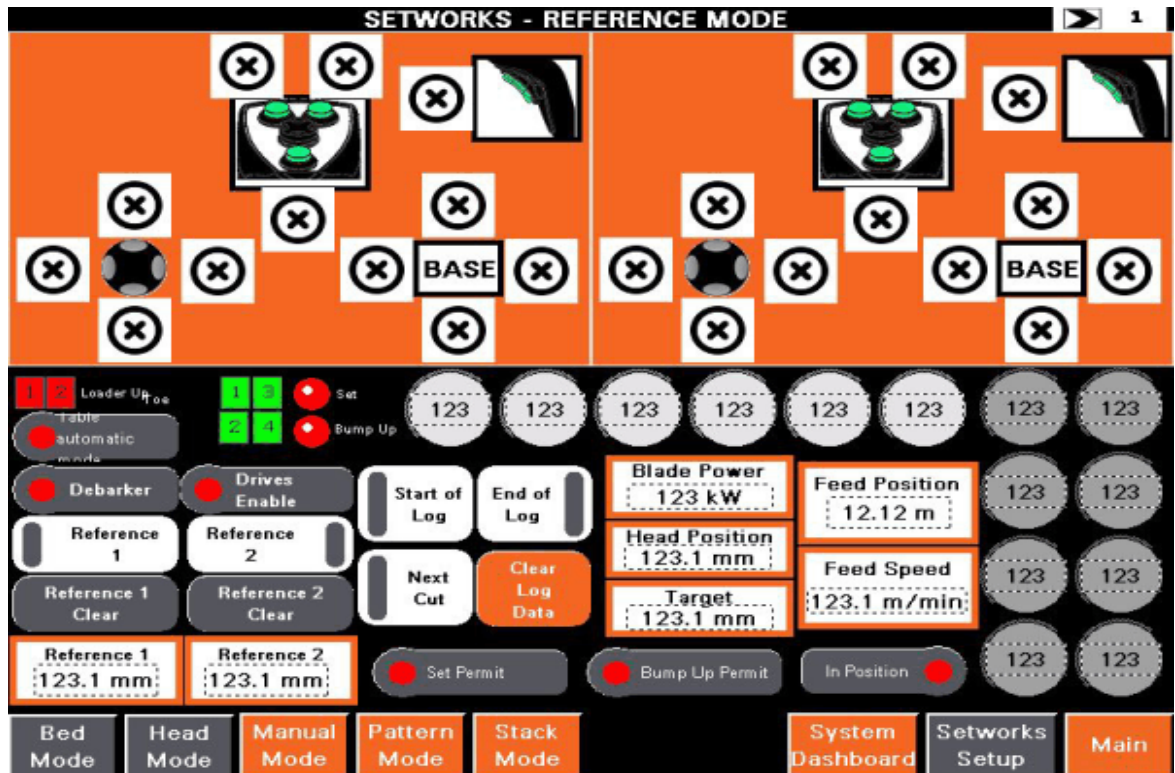

FIG. 3-17

See Figure 3-18 There are also four Stacks in Stack mode. Each stack has ten sizes.

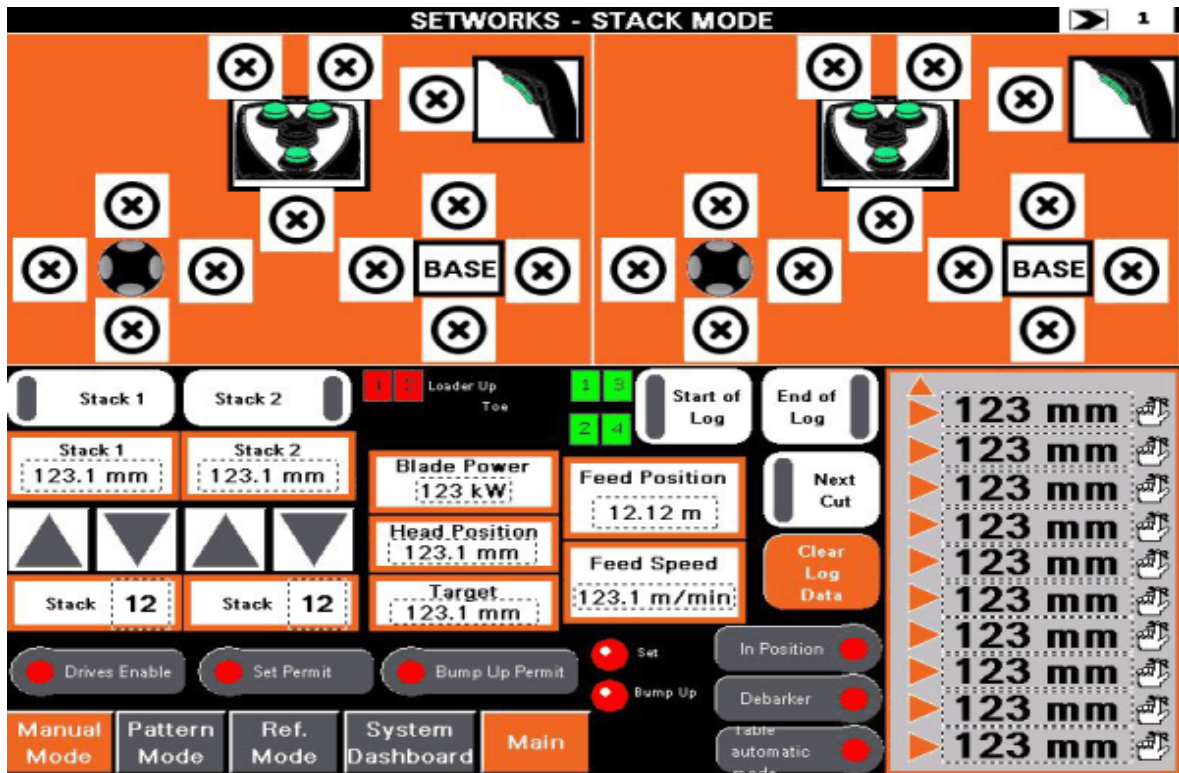

FIG. 3-18

To program the Board Sizes, Cant Sizes, and Stack Sizes you have to go to the “Setworks Setup” screen. From the Main screen just press the “Setworks Setup” screen. From Reference or Pattern mode also press the “Setworks Setup” screen. If you want to change board or cant sizes while cutting a log, you must use the buttons located in the mode you are in so that you do not leave setworks and delete all your log date, i.e. Start of Log Position, End of Log Position, or Reference positions.

The Kerf Size is also setup on this screen.

Fractional Size Setup

See Figure 3-19 The Setworks Setup screen is shown below.

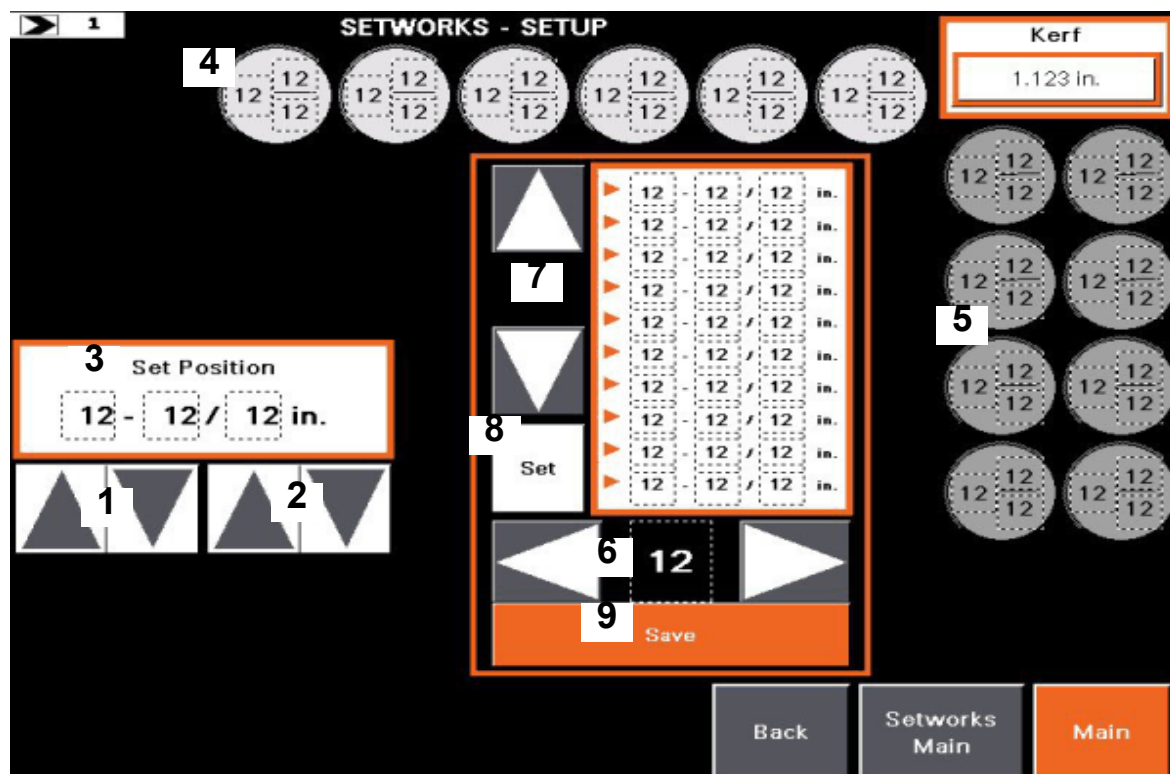

FIG. 3-19

- (1) Use these arrows to increase or decrease the size by whole inches.
- (2) Use these arrows to increase or decrease the size by a thirty-second of an inch.
- (3) This display shows the size selected.
- (4) Press one of the board size buttons to set it to the size selected.
- (5) Press one of the cant size buttons to set it to the size selected.
- (6) Choose the Stack to you want to set with these buttons.
- (7) Choose the position of the stack to edit.
 - Each size above the one set will be filled with the value entered.
- (8) Press the “Set” button to set the position of the stack to the size selected.
- (9) When the Stack is full, press the “Save” button to keep it in memory.

Decimal Size Setup

See Figure 3-20 The Setworks Setup screen is shown below.

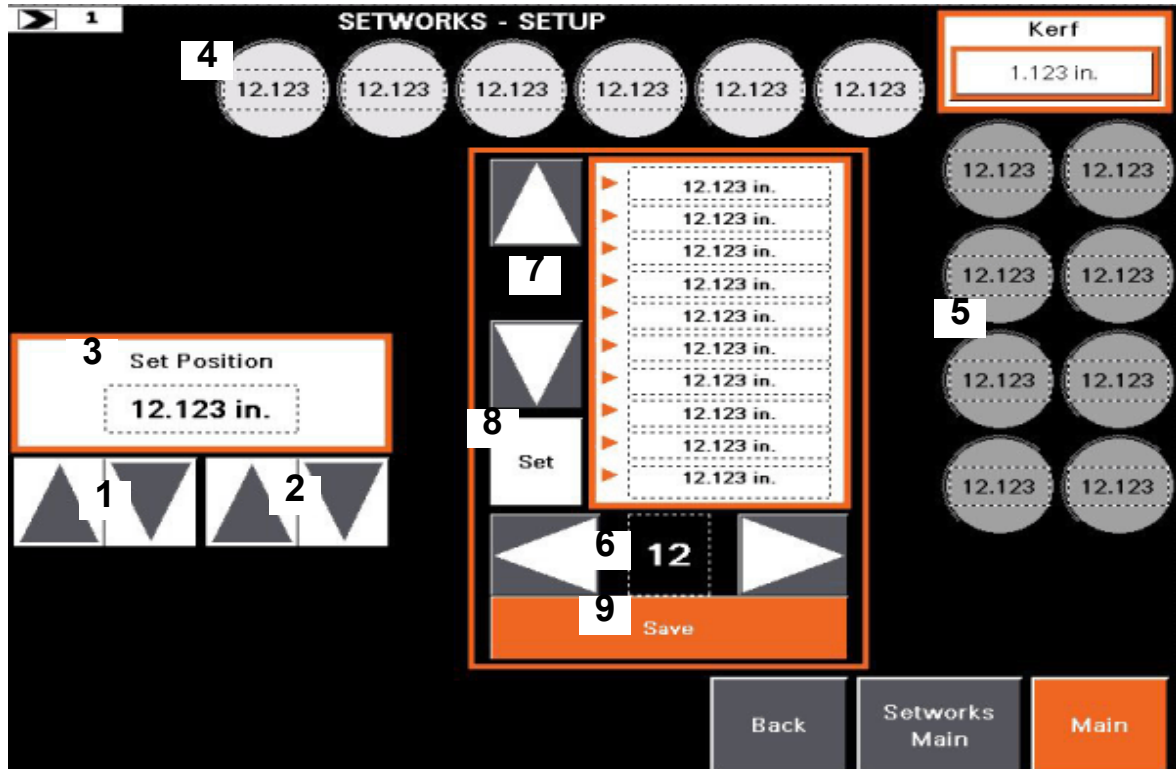

FIG. 3-20

- (1) Use these arrows to increase or decrease the size by whole inches.
- (2) Use these arrows to increase or decrease the size by a thirty-second of an inch.
- (3) This display shows the size selected.
- (4) Press one of the board size buttons to set it to the size selected.
- (5) Press one of the cant size buttons to set it to the size selected.
- (6) Choose the Stack to set with these buttons.
- (7) Choose the position of the stack to edit.
 - Each size above the one set will be filled with the value entered.
- (8) Press the “Set” button to set the position of the stack to the size selected.
- (9) When the Stack is full, press the “Save” button to keep it in memory.

Metric Size Setup

See Figure 3-21 The Networks Setup screen is shown below.

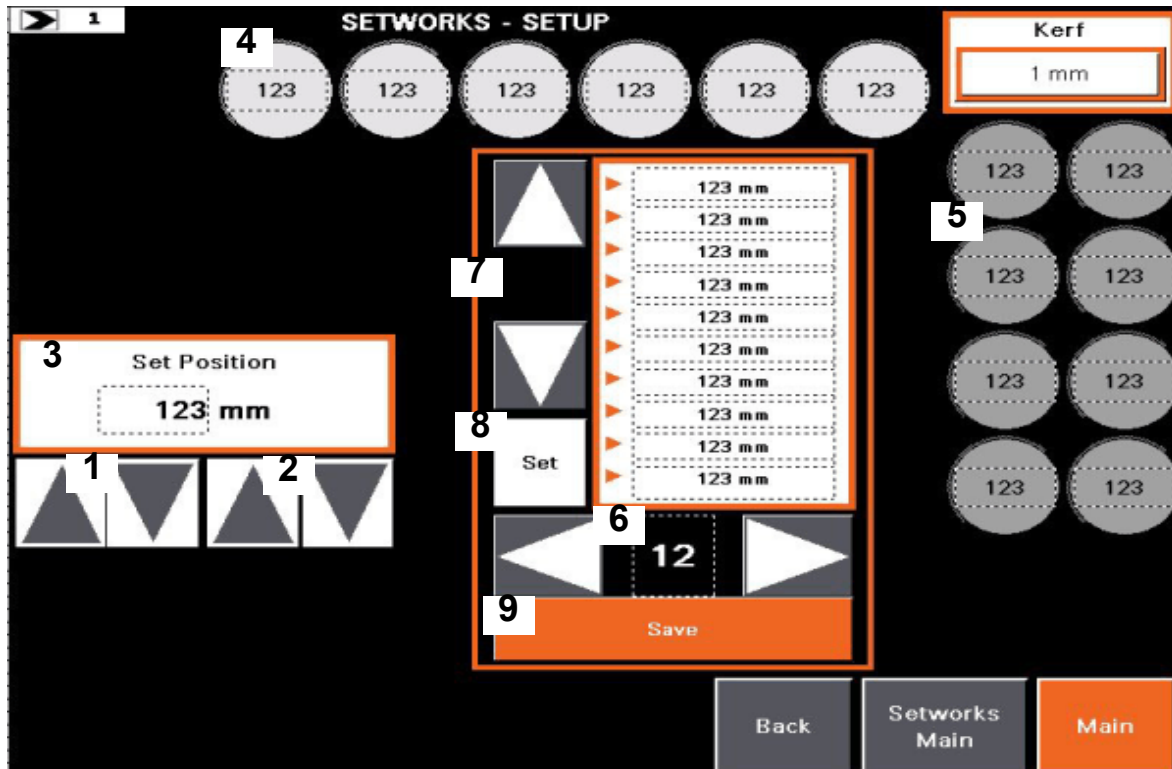

FIG. 3-21

- (1) Use these arrows to increase or decrease the size by 10mm.
- (2) Use these arrows to increase or decrease the size by 1mm.
- (3) This display shows the size selected.
- (4) Press one of the board size buttons to set it to the size selected.
- (5) Press one of the cant size buttons to set it to the size selected.
- (6) Choose the Stack to you want to set with these buttons.
- (7) Choose the position of the stack to edit.
 - Each size above the one set will be filled with the value entered.
- (8) Press the “Set” button to set the position of the stack to the size selected.
- (9) When the Stack is full, press the “Save” button to keep it in memory.

3.4.9 Adjustable Belt Conveyor Setting

To go to the Adjustable Belt Conveyor settings, select "Setup" in the main menu and then "Adjustable Belt Conveyor Config." (A).

NOTE: this option is available only if the controller reads the signal from the table height sensor.

See Figure 3-22

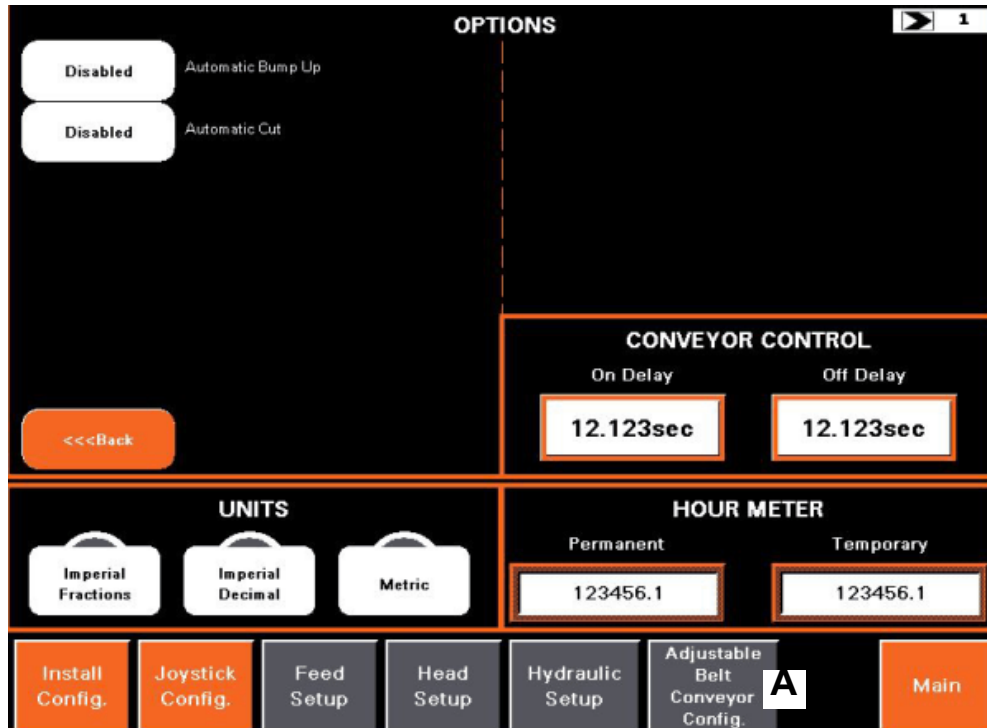

FIG. 3-22

3 Setup & Operation

Adjustable Belt Conveyor Configuration

3.4.10 Adjustable Belt Conveyor Configuration

See Figure 3-23

The picture below shows the Adjustable Belt Conveyor configuration window. Its most important element is "Conveyor Auto Mode" (B) button which activates the conveyor. When this button is of a lighter shade of colour, as shown below, it means that the conveyor is turned off. As soon as the button is pressed, its colour will change and the conveyor will be activated.

Note: upon activation, the table will rise automatically to the preset height that is read based on the saw head position. When the table is deactivated, it lowers to the minimum position.

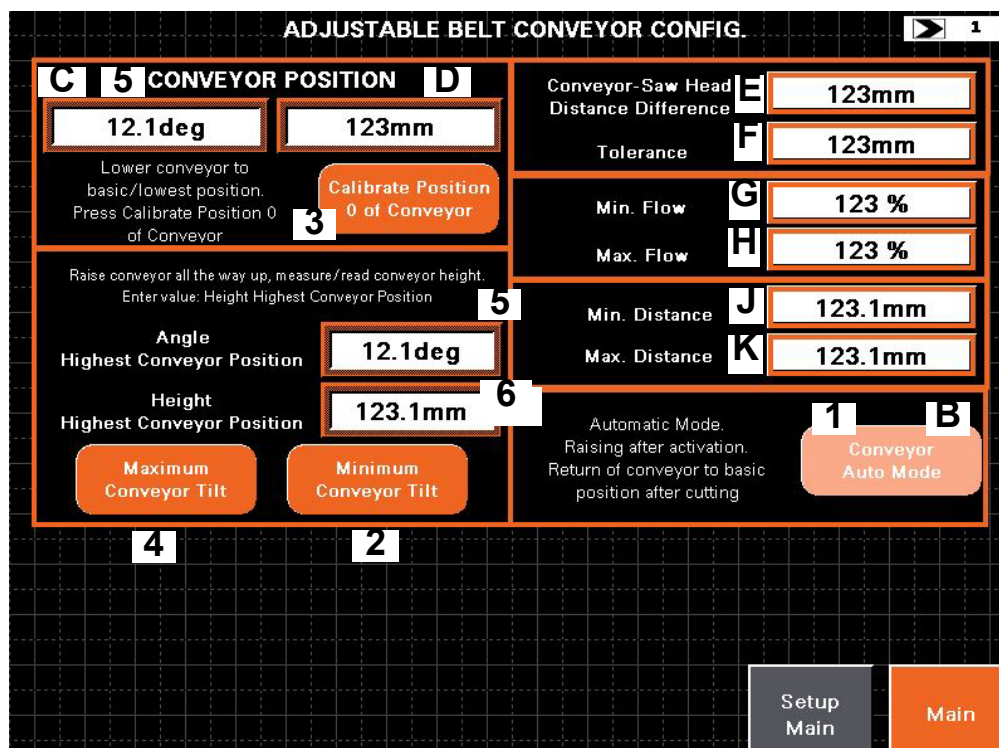

FIG. 3-23

In the upper left part of the configuration window you can see the table position in degrees (C) and the calculated table height in millimetres (D).

In order for the displayed table height is the actual height, the height calibration should be performed - for the first time or when the displayed value is incorrect.

3.4.11 Conveyor Height Calibration

1. Make sure the Auto Mode - "**Conveyor Auto Mode**" is disabled and the saw head is not above the Adjustable Belt Conveyor.
2. Use the button "**Minimum Conveyor Tilt**". After pressing this button, the table will move to its lowest position.
3. Push the button "**Calibrate Position 0 of Conveyor**". The minimum position will be overwritten.
4. Press the button „**Maximum Conveyor Tilt**". The table will be tilted to the maximum position.
5. Read the table angle in the first window of the CONVEYOR POSITION and enter this value into the window "**Angle. Highest Conveyor Position**" - just click on the existing value and use the numeric keypad that will appear on the screen.
6. Measure from the bed to the highest point of the table and enter this value into the window showing the maximum table height.

In the right part of the configuration window the preset table parameters are displayed. They are used to correct operation of the table. These parameters are appropriately selected, but it is possible to change them in order to fine-tune them individually.

(E) „Conveyor-Saw Head, Distance Difference" (range 130-500mm, factory setting 200mm)

This is the difference between the saw head height and the table height. The difference should be increased when extremely low table speed is preset to avoid collision of the table with the saw head.

(F) „Tolerance" (range 10-100mm, factory setting 30mm)

This is the range of distances from the table's "target" for which the table does not move. Setting a lower value will make the table respond faster, while a higher value will reduce the frequency of starting positioning.

(G) „Min. Flow" (range 5-100%, factory setting 15%)

This is the minimum flow of hydraulic fluid onto the Adjustable Belt Conveyor.

(H) „Max. Flow" (range 10-100%, factory setting 35%)

This is the maximum flow of hydraulic fluid onto the Adjustable Belt Conveyor.

(J) „Min. Distance" (range 0-100mm, factory setting 70mm)

Below this distance from the target, the hydraulic fluid flow is minimum.

(K) „Max. Distance" (range 0-200mm, factory setting 100mm)

Above this distance from the target, the hydraulic fluid flow is maximum.

Between the minimum and maximum value, the fluid flow is proportional in the range from the minimum to the maximum value.

3.5 Replacing the Blade



DANGER! Always shut off the sawmill motor before changing the blade. Failure to do so may result in serious injury.



WARNING! Always wear gloves and eye protection whenever handling a bandsaw blade. Changing blades is safest when done by one person! Keep all other persons away from work area when changing blades. Failure to do so may result in serious injury.



WARNING! In case of the blade or drive belt brake, wait until all rotating parts are completely stop. Failure to do so may result in serious injury.

Move the blade guide arm out.

Open the blade housing covers. Release the blade tension ([See Section 3.6](#)) until the wheel is pulled in and the blade is lying loose in the blade housing. Carefully remove the blade from the blade housing.

Install the blade so it is lying around the wheels. When installing the blade, make sure the teeth are pointing the correct direction. The teeth should be pointing toward the operator side of the sawmill when you are looking at the blade below the blade guides, as shown on the label located on the blade housing.

Position 3.5" (90mm) wide blades on the wheels so the gullet is 8 mm (0.314") out from the front edge of the wheel

Close the blade housing. Next, use the blade tension handle to tension the blade correctly.



CAUTION! When adjusting the blade position, be extremely careful, because your fingers can get pinched.

3.6 Tensioning the Blade

See Table. 3-2. WB2000 pneumatic and hydraulic approximate tension values are shown below.

Hydraulic presure PSI/Bar	Operating pneumatic presure PSI	Preload pneumatic presure PSI
715/50	20	15
1100/75	30	22
1300/90	40	30
1450/100	50	37
1600/110	65	50

TABLE. 3-1

See Figure 3-24

1. According to used blade, inflate Bellow Cylinder to Preload Pneumatic PSI.

To inflate Bellow Cylinder connect air pressure hose to the fitting shown on the picture below.

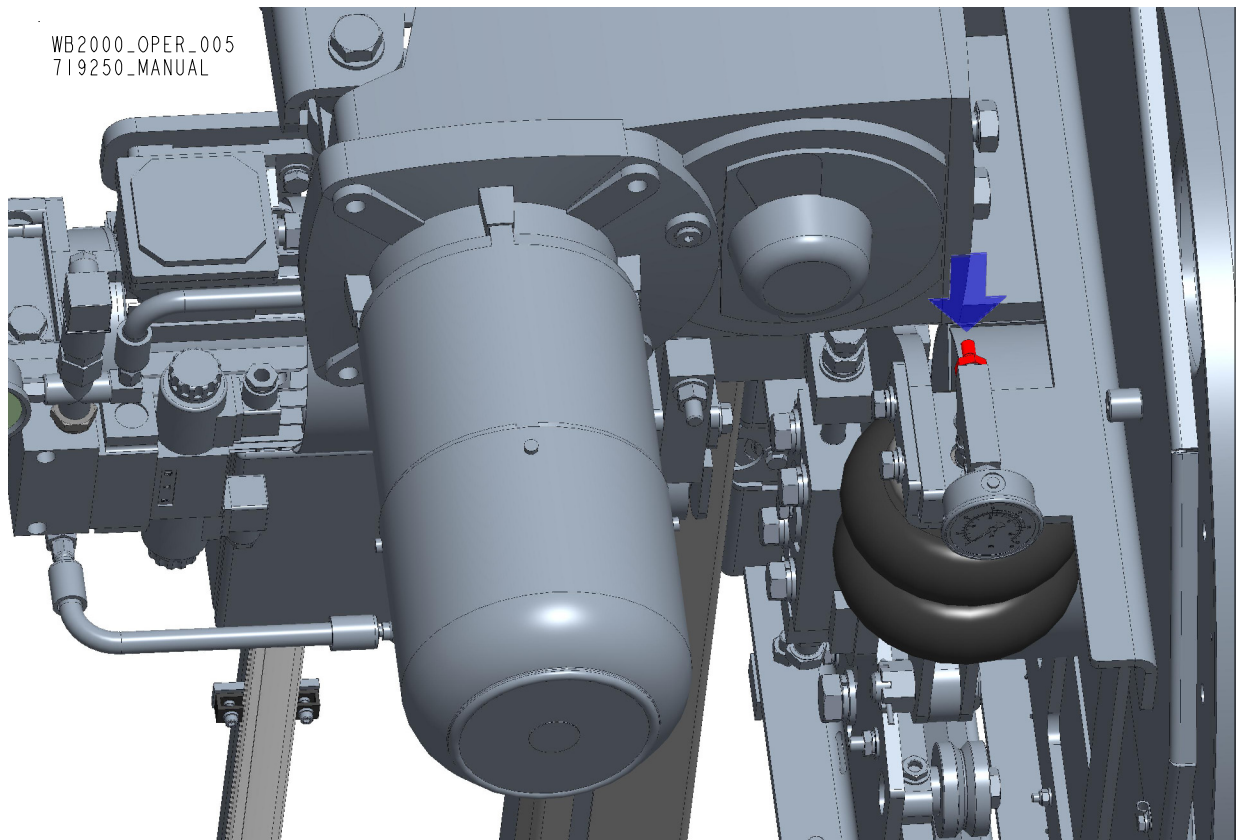

FIG. 3-24

3 Setup & Operation

Tensioning the Blade

See Figure 3-25

2. According to used blade, set hydraulic pressure. To set hydraulic pressure use buttons on the box show on the picture below. At the same time observe the Bellow Cylinder to see if it deforms. If necessary adjust the air pressure in the Bellow Cylinder.

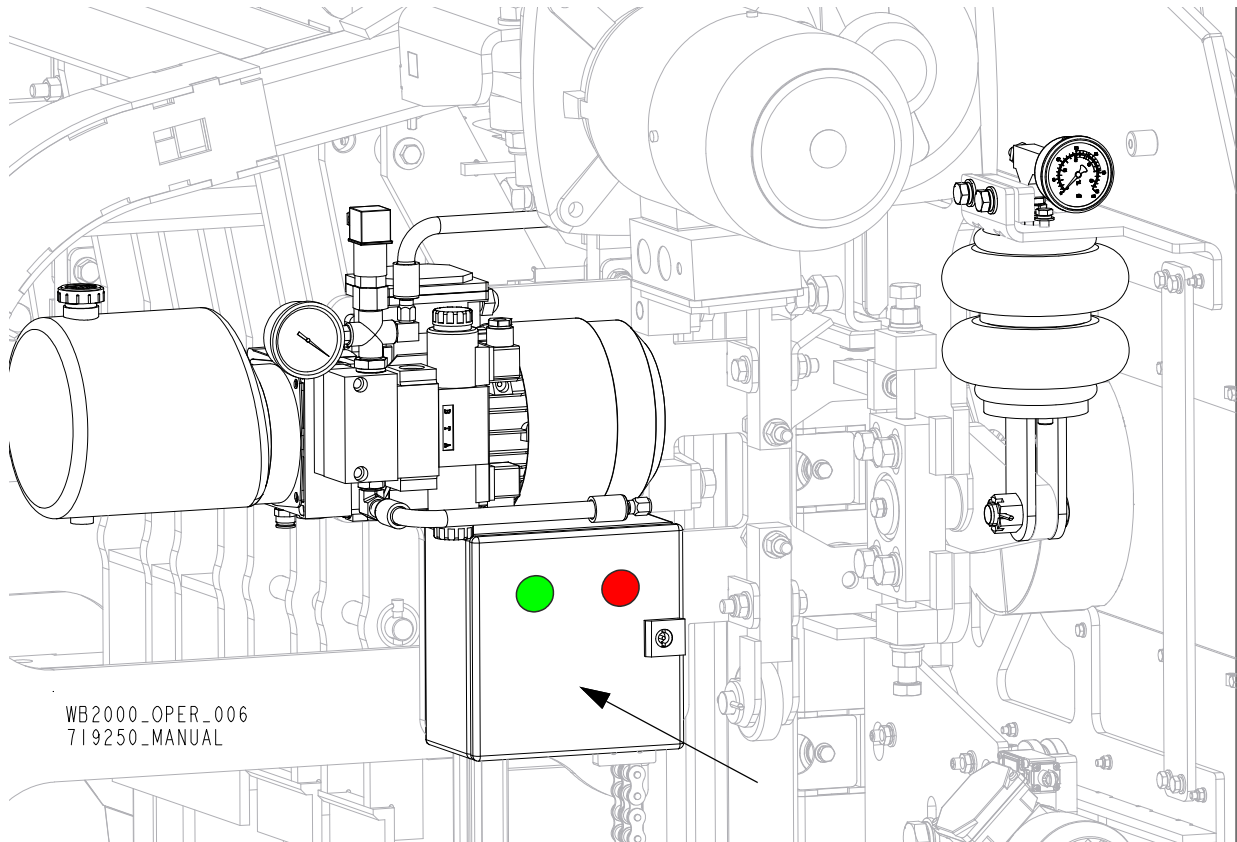

FIG. 3-25



IMPORTANT! Adjust the air in the Bellow Cylinder so that the Compensation Arm is horizontal.

See Figure 3-26.

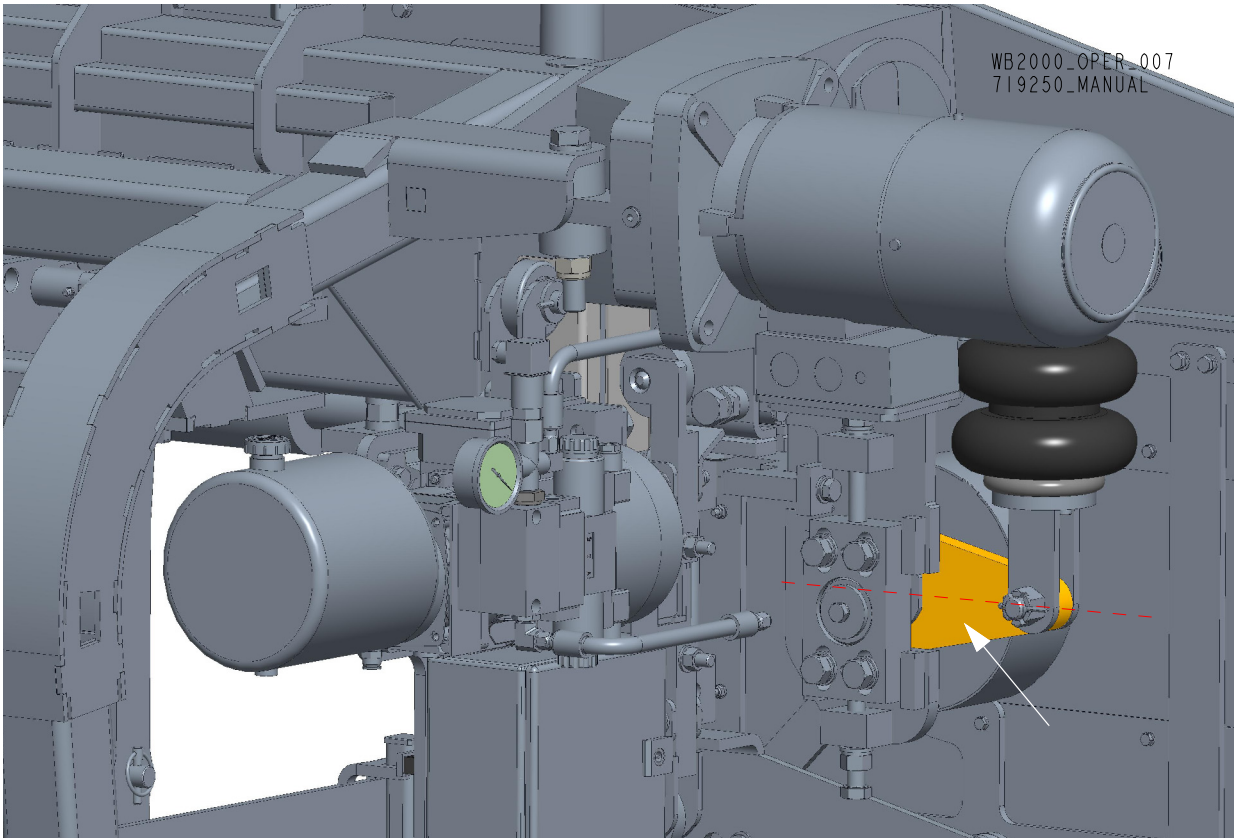

FIG. 3-26

Check the blade tension occasionally when adjusting the cant control or while cutting. Also, ambient temperature changes can cause tension to change.



CAUTION! Release the blade tension when the resaw is not in use (for example at the end of a shift). Tension the blade again before starting the motor.



WARNING! In case of a blade or drive belt brake, wait until all rotating parts are completely stop. Failure to do so may result in serious injury.

The WB2000 sawmill is equipped with a safety switch that disengage the motor until the blade is properly tensioned (the motor is stopped also when the blade breaks).

3.7 Tracking the Blade

1. Open the blade housing.
2. Turn the key switch to the "H" position.



3. Carefully spin by hand one of the blade wheels until the blade positions itself on them.
4. Check if the blade is properly positioned on the blade wheels.

See Figure 3-27 Position 3.5" (90mm) wide blades on the wheels so the gullet is 8 mm (0.314") out from the front edge of the wheel.

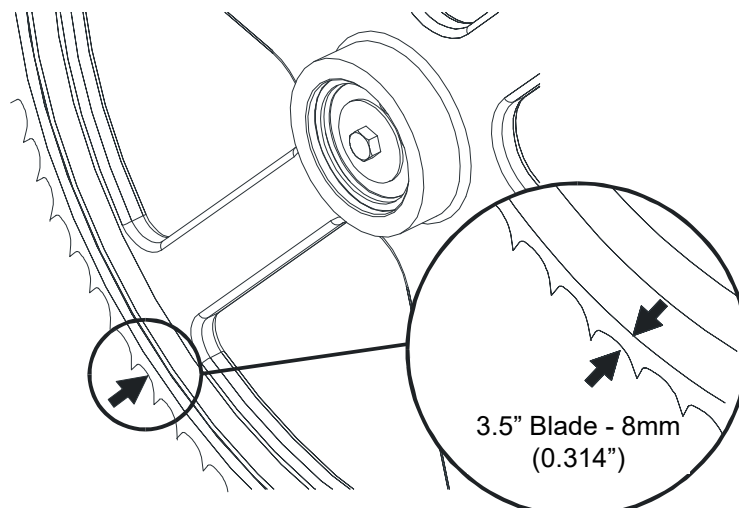

FIG. 3-27

See Figure 3-28

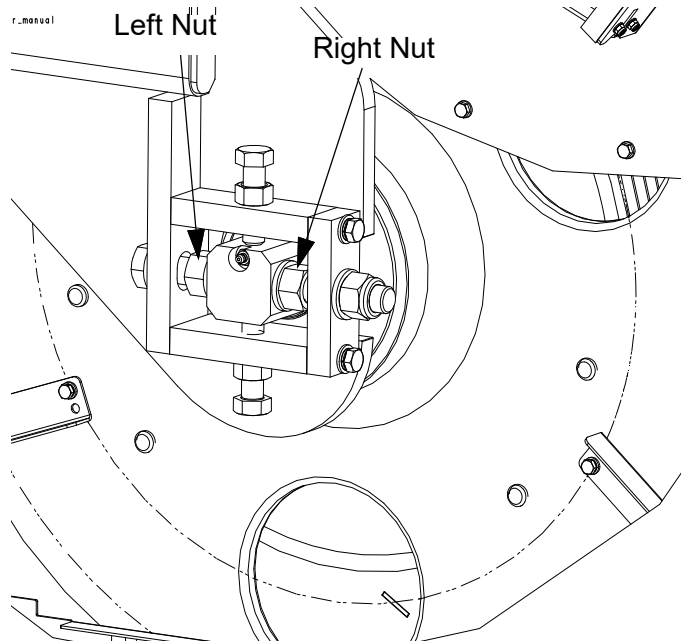

FIG. 3-28

5. On the drive side use the cant adjustment nuts, shown in **Figure 3-29**, to adjust when the blade travels on the blade wheels.

To move the blade out on the blade wheel, turn the cant adjustment nuts clockwise. To move the blade in on the blade wheel, turn the nuts counterclockwise.

3 Setup & Operation

Starting the Motor

See Figure 3-29

6. On the idle side loose the bolts (A) and use the adjustment nut (B), to adjust when the blade travels on the blade wheels. After adjusting tighten the bolts (A)

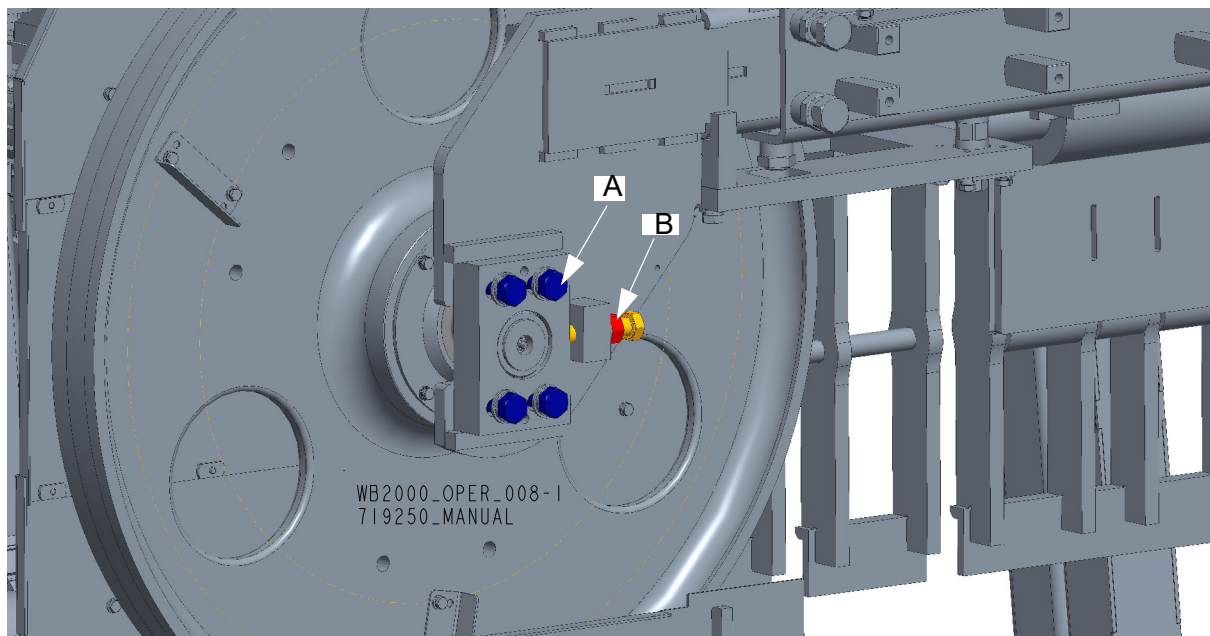



FIG. 3-29

7. After making the cant adjustment, tension the blade properly and then re-check the cant adjustment.
8. Close the blade housing.

 **DANGER!** Make sure all guards and covers are in place and secured before operating or towing the sawmill. Failure to do so may result in serious injury. Be sure the blade housing covers are in place and secured.

DANGER! After adjusting the blade wheels, always recheck the blade tracking.

3.8 Starting the Motor

See the appropriate manual supplied with your specific motor configuration for detailed starting and operating instructions.

 **IMPORTANT!** For safe operation of the sawmill, one person is sufficient, however in case of manual collection of sawn material, at least two persons should be assigned to these activities in order not to exceed the manual lifting standard.

 **CAUTION!** Before starting the sawmill, the operator must warn all persons

who are nearby of the intention of starting the machine.



IMPORTANT! The sawmill should be operated only by a qualified person of age, being in good state of health confirmed by a medical certificate.

IMPORTANT! When starting the machine for the first time, check that the main motor rotation direction is as indicated by the arrow located on the motor body (fan guard). If the rotation direction is incorrect, invert the phases in the phase inverter in the power socket (electric box). Setting the phases in the phase inverter correctly will ensure correct rotation directions of all sawmill motors.



CAUTION! Make sure all guards and covers are in place and secured before operating. Failure to do so may result in serious injury. Be sure the blade housing covers are in place and secured.



CAUTION! Always wear eye, ear, respiration and foot protection when operating the machine. Secure all loose clothing and jewelry before operating the sawmill.

CAUTION! Before starting the sawmill, connect a sawdust extraction system to the sawdust chute and start the extraction system. For the sawdust extractor specifications.

CAUTION! If at any time you need to immediately stop the blade motor, press the emergency stop button located on the control box.

Before starting the sawmill at a new location, at least once a year or after every repair have a qualified electrician (having appropriate measurement qualifications) check the insulation resistance and the electric shock protection of the electrical system.

The electric box should be protected against dust and moisture. Regularly disconnect the power supply and clean the inside of the electric box of dust, sawdust, etc. Do not operate or leave the sawmill with the electric box door open.



CAUTION! Hazardous voltage inside the electric box (even if disconnected with the main disconnect switch) and at the motor can cause shock, burns, or death. Always disconnect the power supply before servicing!

3.9 Lube System Operation

The Lube System keeps the blade and the wheels clean and cools them. The coolant (ACP-1 oil) flows from a 5-liter tank through hoses to both sides of the blade and surfaces of the wheels. Drip feed lubricators located on the saw head control the amount of oil flow.

Use just as much coolant as it is necessary to keep the blade clean. Usually, it is sufficient to set the drip feed lubricators so that one drop flows every 3 seconds.



WARNING! Never use flammable fuels or liquids! If these types of liquids are necessary to clean the blade, remove it and clean with a rag. Failure to do so may result in serious injury or death.

Before removing the blade, start the motor with the START button. Let the blade spin with oil running on it for about 15 seconds. This will clean the blade of sap buildup. Wipe the blade dry with a rag before storing or sharpening.

If you are sawing in temperatures below -20°C (-4°F), remove the oil tank from the sawmill when done sawing and store it in a warm place. Blow any remaining oil from the lube hose.

3.10 Vision Camera

See Figure 3-30 Mount vision camera as shown in the picture below

WB2000MEC50HS5U_001
WB2000MEC50HS5U_MANUAL

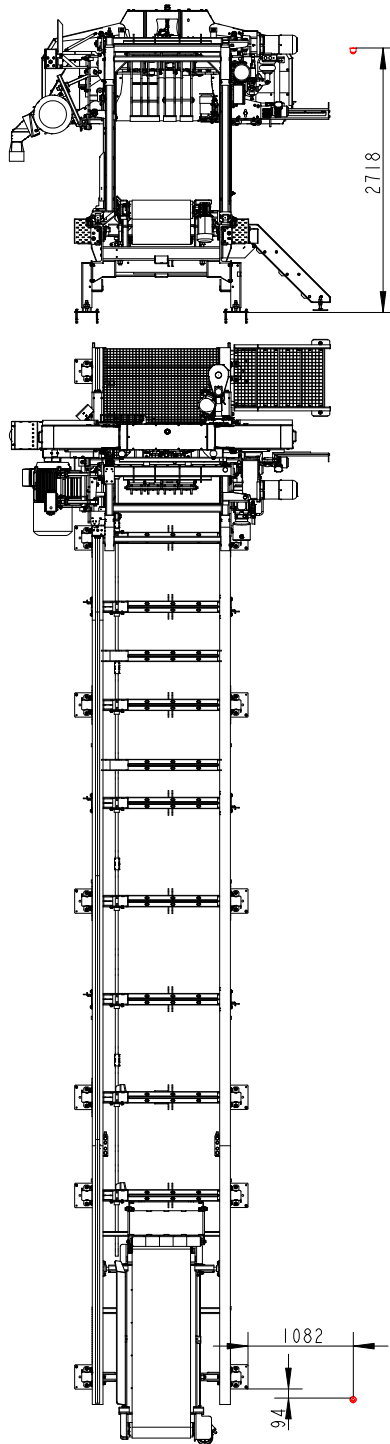

FIG. 3-30

3.11 Pantograph Cable Boom

IMPORTANT! Make sure there is enough room around the sawmill for the pantograph movement after the pantograph assembly installation is complete.

See **Figure 3-31** Position the pantograph next to the sawmill bed as shown. (**NOTE:** The assembled pantograph is shown below.)

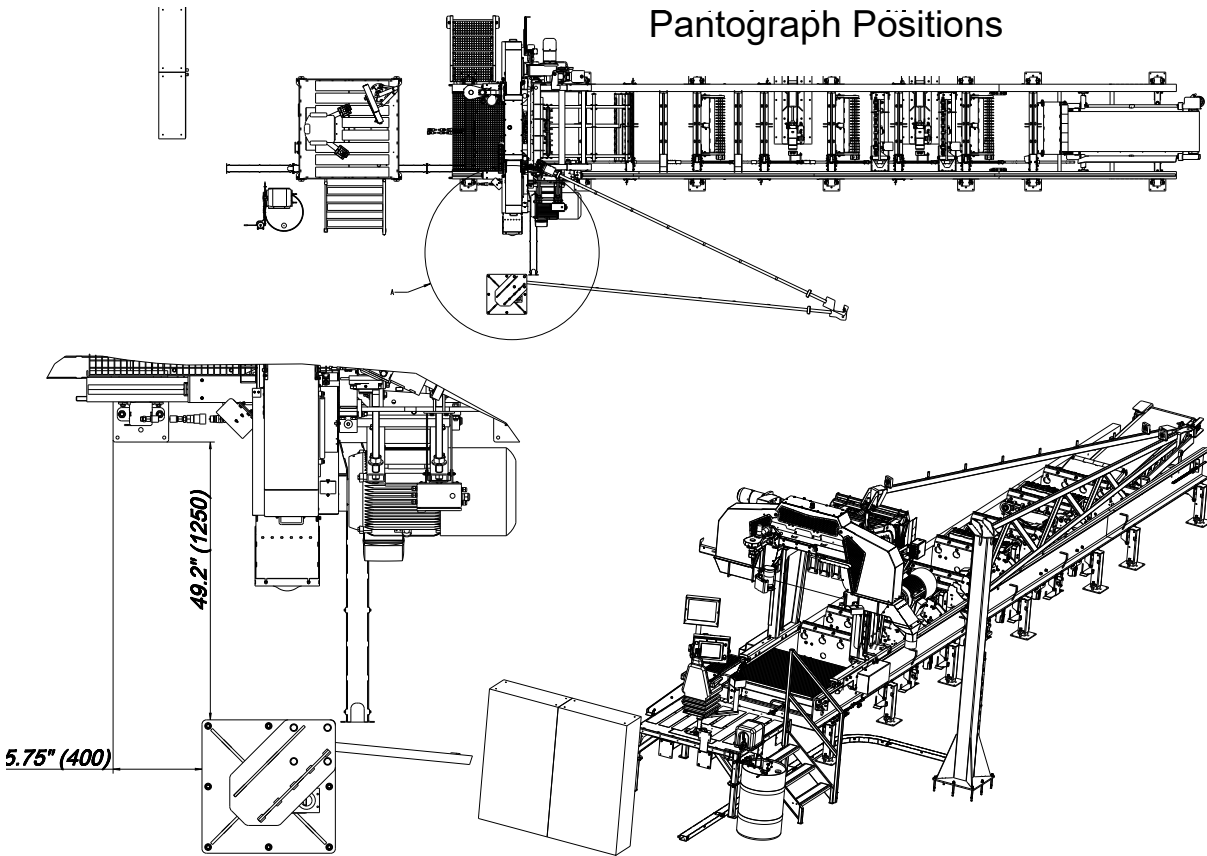
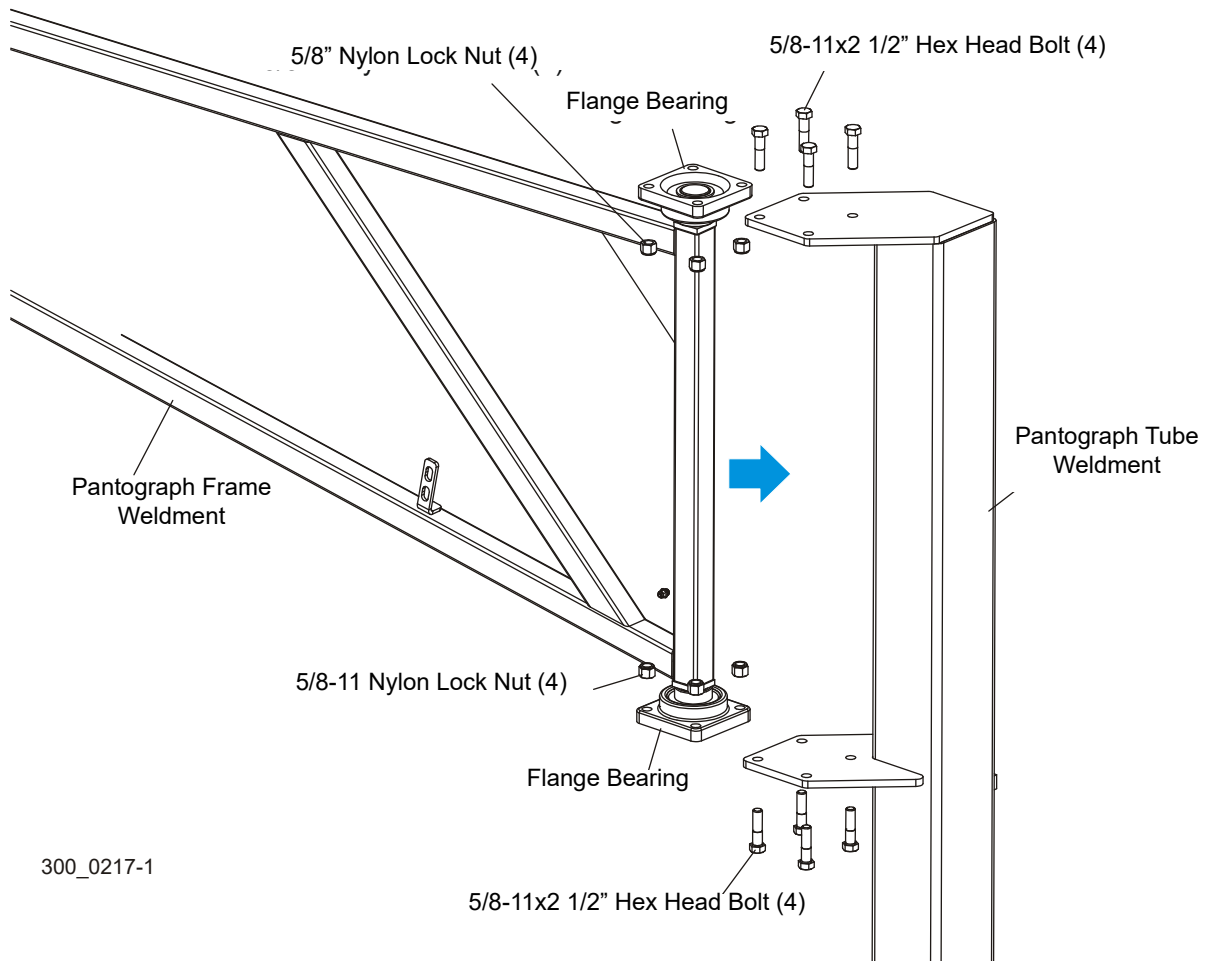

FIG. 3-31

9. Secure the pantograph main tube weldment to the ground with eight anchor bolts. A cement pad with 1/2" diameter anchor bolts is recommended.
10. Install the pantograph frame weldment to the main tube. Install the two provided flange bearings to the upper and lower pivot ends on the frame weldment. Use the provided 5/8-11 x 2 1/2" hex head bolts and 5/8-11 nylon lock nuts to secure the frame weldment to the main tube.

See Figure 3-32



300_0217-1

FIG. 3-32

3 Setup

Pantograph Cable Boom

11. Install the connector weldment to the end of the frame weldment as shown below. Use the provided parts to make the required connection.

See Figure 3-33

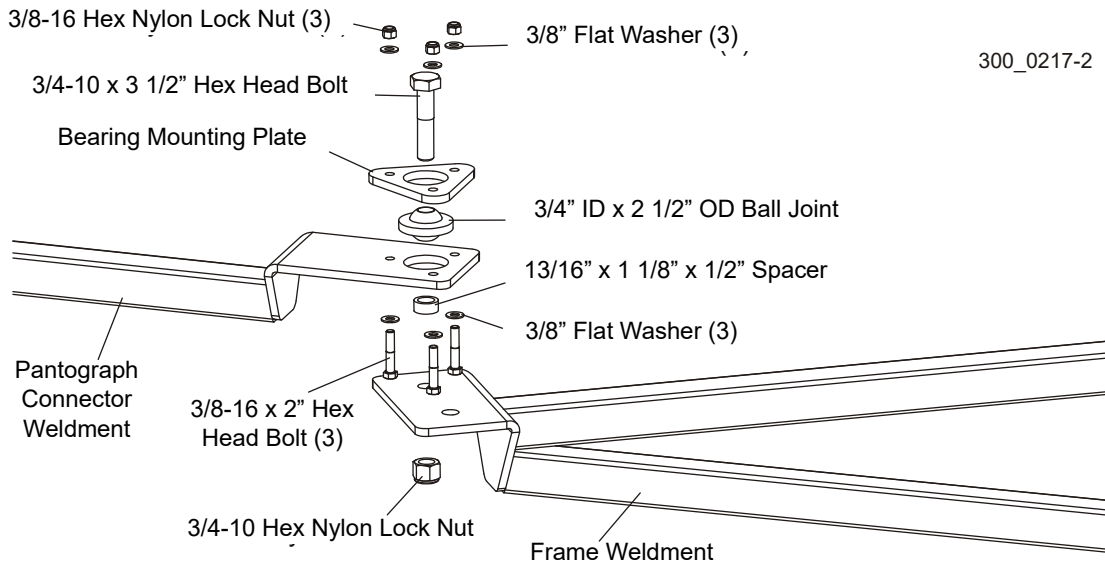

FIG. 3-33

12. Install the pantograph pivot bracket to the end of the connector weldment. Assemble the provided parts as shown below.

See Figure 3-34

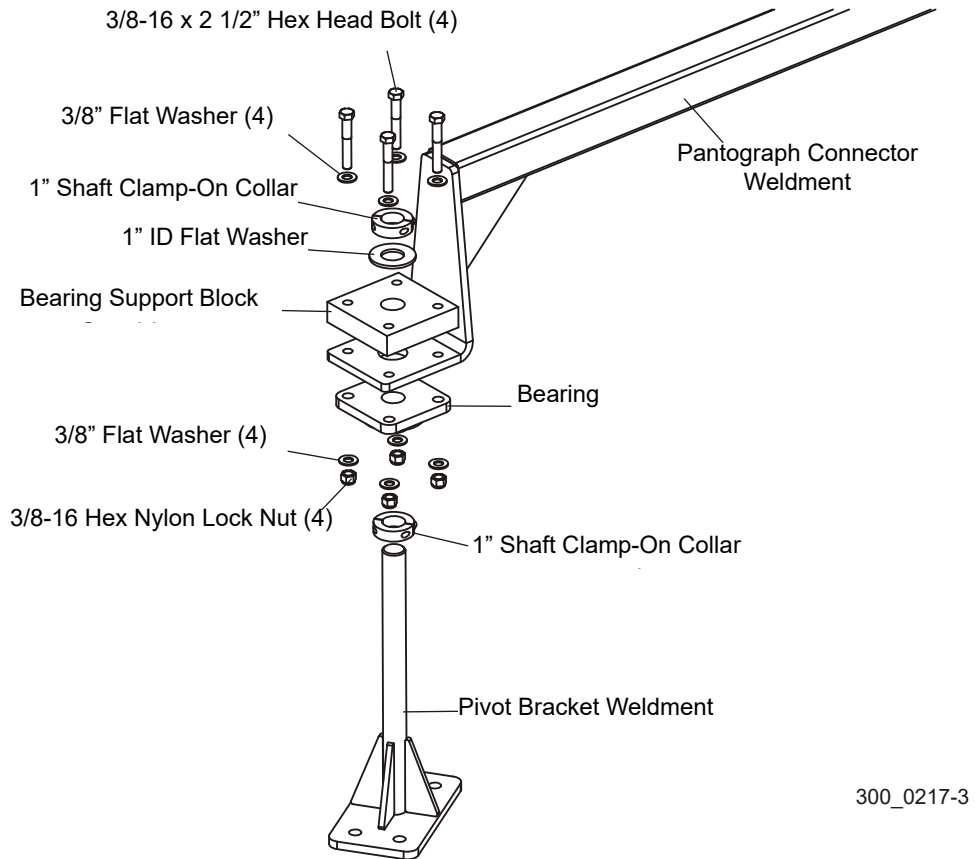

FIG. 3-34

3

Setup

Pantograph Cable Boom

13. Move the pantograph connector weldment so that the pivot bracket is located directly above the sawmill mast. Remove the four bolts and lock washers securing the top bellow mount plate to the sawmill mast assembly. Use the provided 1/2-13 x 1 1/2" hex head bolts and the existing lock washers to secure the pivot bracket to the mast.

See Figure 3-35

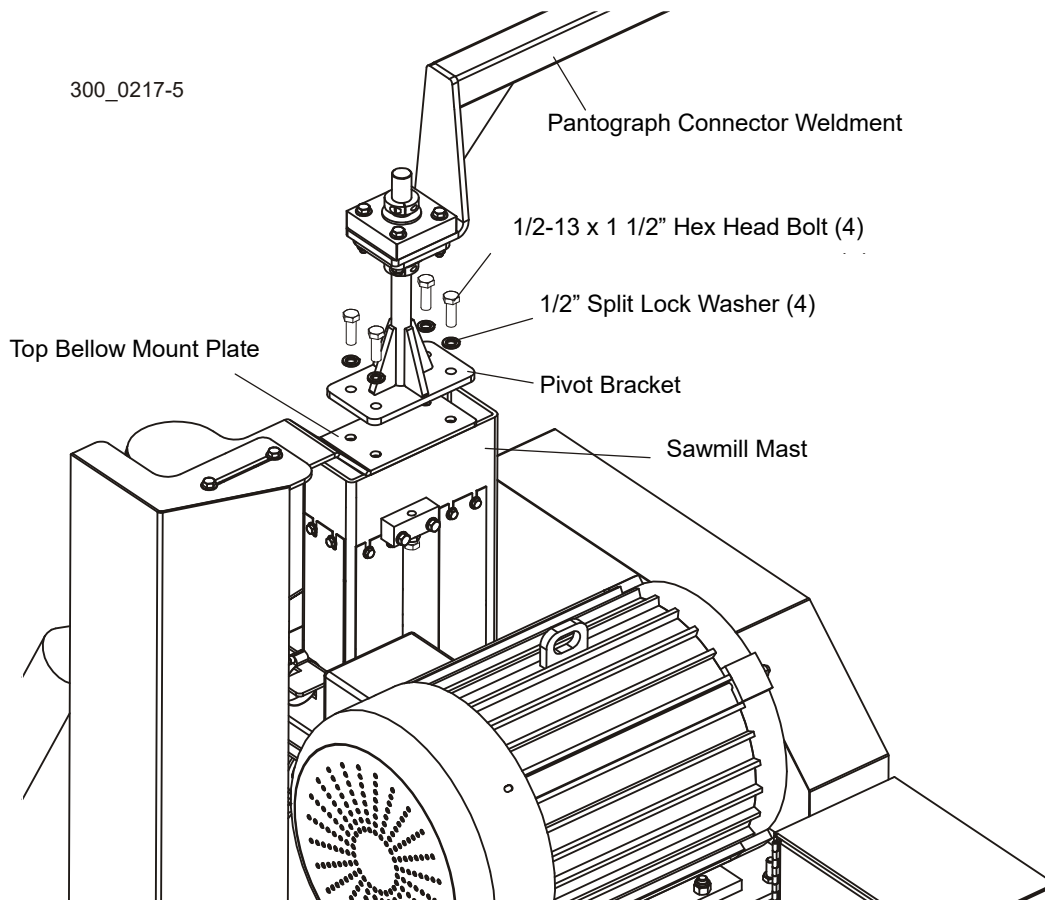

FIG. 3-35

14. Route all the cables, air line and lube hose through the cable glands on the pantograph and secure properly. Use the provided tie wraps to secure the cables, air line and lube hose to the pantograph cable brackets.

See Figure 3-36

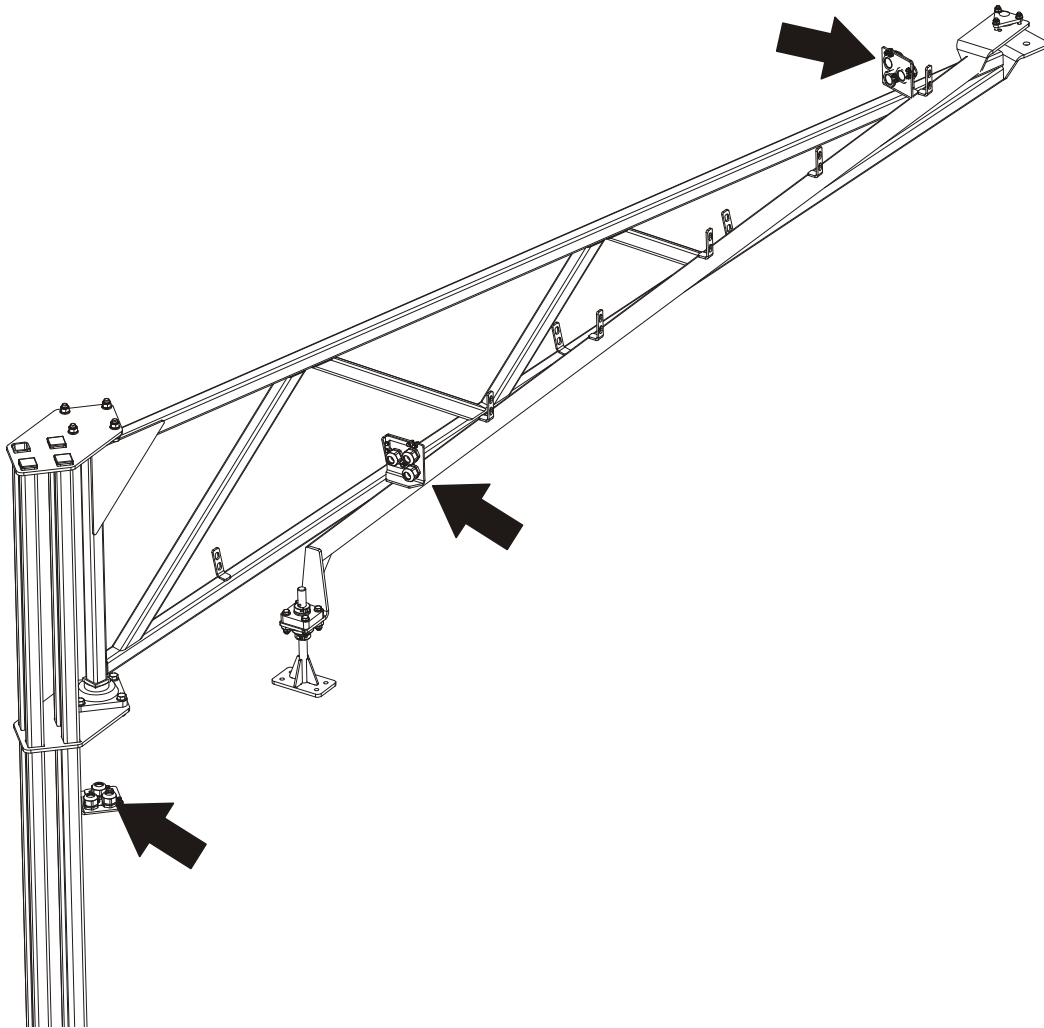

FIG. 3-36

IMPORTANT! Make sure the cables, air line and lube hose are looped at each end of the pantograph weldment to avoid damage when operating the sawmill. Make a larger loop between the pantograph assembly and the saw head for the saw head up/down movement. When pantograph electrical installation is finished, move the saw head to test the pantograph movement. Readjust the loop sizes as necessary.

SECTION 4 MAINTENANCE

This section lists the maintenance procedures that need to be performed.

The Short Interval Maintenance Schedule lists procedures that need to be performed every 4, 8 or 25 hours. The Maintenance Log lists procedures that need to be performed every 50, 100, 200, or 1000 hours. Keep track of machine maintenance by filling in the machine hours and the date you perform each procedure.



WARNING! Disconnect and lock out power supply before servicing, cleaning and doing maintenance to the saw! Failure to do so may result in serious injury.



This symbol identifies the interval (hours of operation) at which each maintenance procedure should be performed.

4.1 Wear Life

See Table. 4-1. This chart lists estimated life expectancy of common replacement parts if proper maintenance and operation procedures are followed. Due to the many variables which exist during sawmill operation, actual part life may vary significantly. This information is provided so that you may plan ahead in ordering replacement parts.

Part Description	Estimated Life
Up/Down Motor	2000 hours
Power Feed Motor	1500 hours
Blade Wheel Bearings	1000 hours
Up/Down Rollers Bearings	1500 hours
Track Rollers Bearings	1000 hours
Drive V-belts	800 hours
Blade Wheel Belts	400 hours
Up/Down Drive Belt and Power Feed Drive Belt	1000 hours
Blade Guide Rollers Bearings	500 hours
Changing the Hydraulic Oil Filter and Checking and Refilling the Oil Level	600 hours
Up/Down and Power Feed Chains with Sprockets	2 years or 2000 hours
Chain Log Turner – Changing Sprockets and Chain	1500 hours
Self-Lubricating Bushings	1500 hours

TABLE. 4-1

4.2 Cleaning and Maintenance

Only guards and covers listed below can be dismounted by the operator for maintenance and cleaning purposes.

- Blade wheel covers

See Figure 4-1.

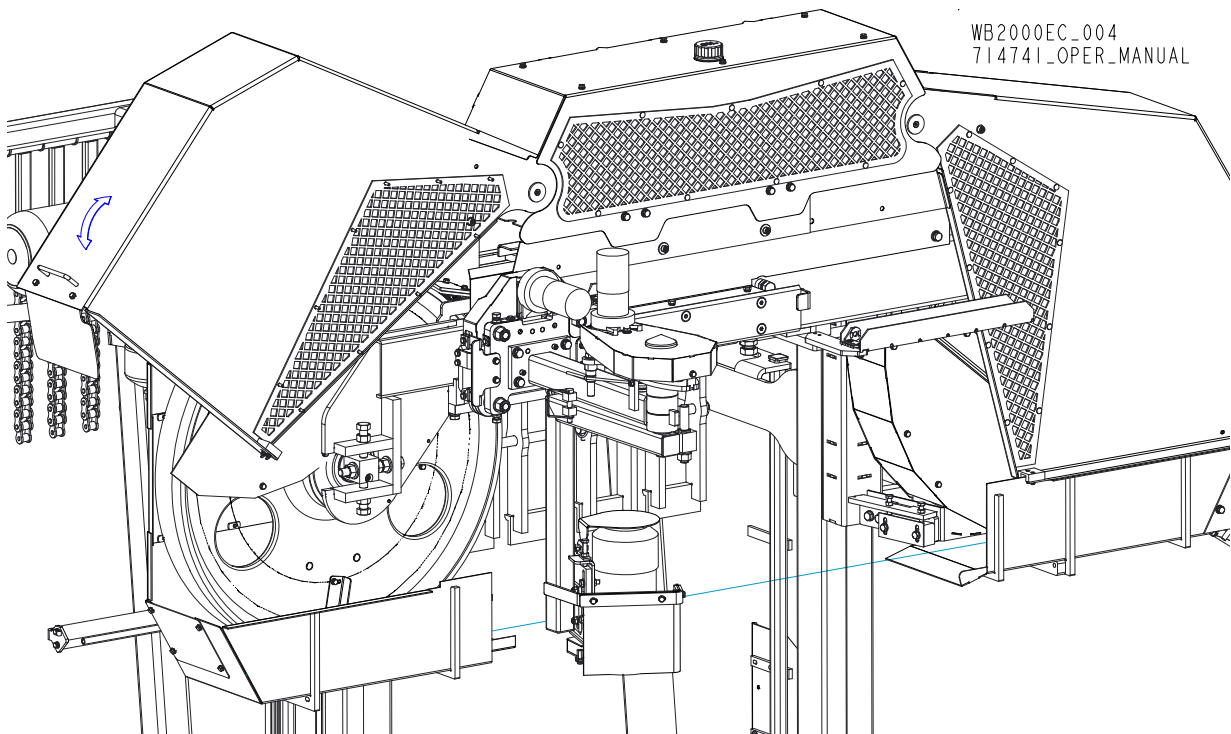

FIG. 4-1.

- Debarker in/out drive belt cover

See Figure 4-2.

WB003
714741_OPER_MANUAL

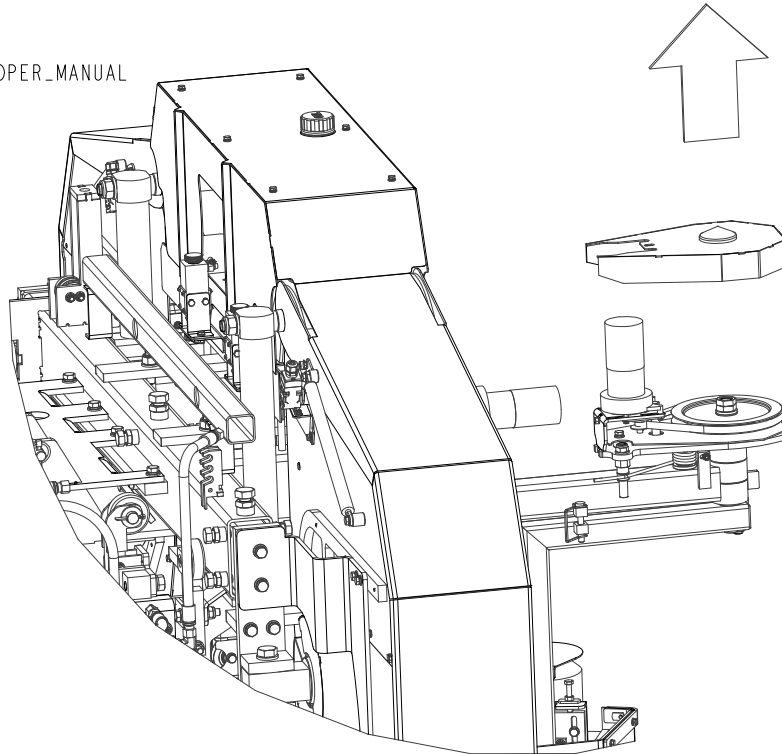

FIG. 4-2.

- Blade drive belt cover

See Figure 4-3.

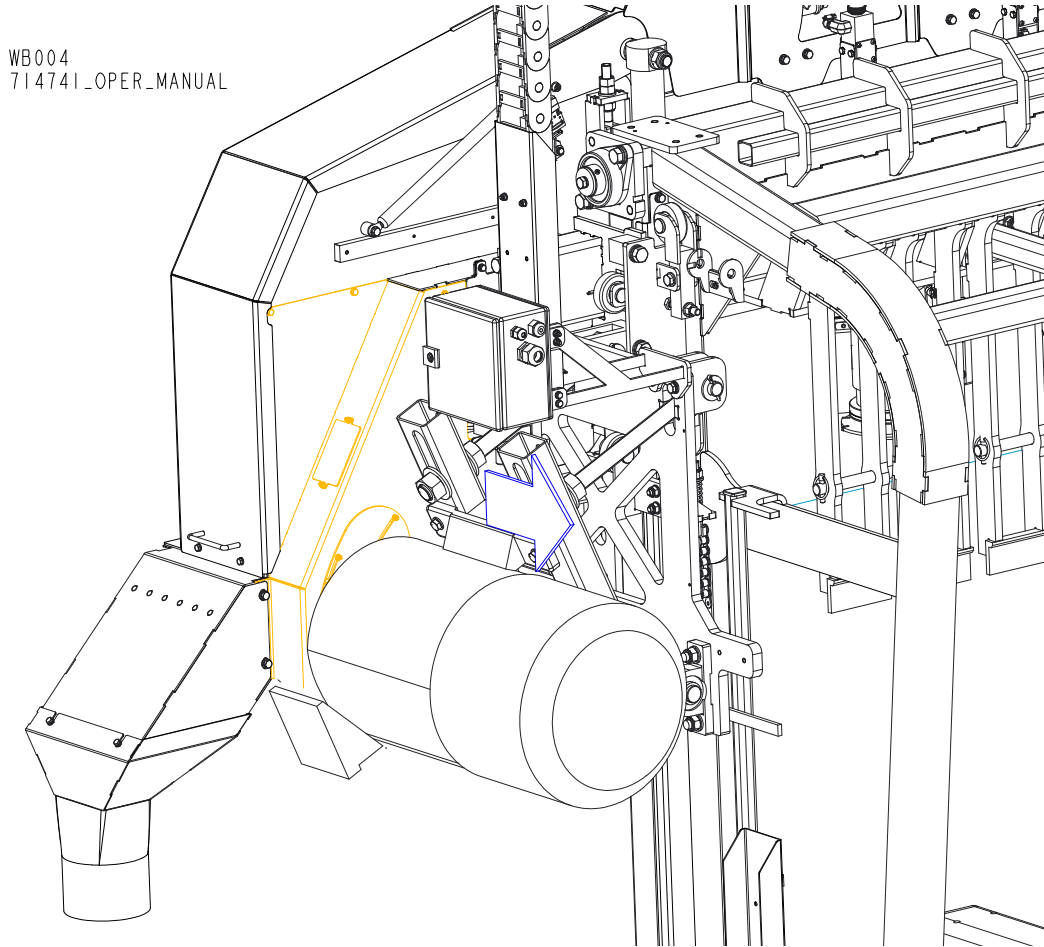

FIG. 4-3.

4.3 Power Feed

1. Check the feed chain tension every 50 hours of operation and adjust as needed. Measure the power feed chain tension with the saw head all the way toward the control station. Use the adjustment nut on the feed tensioner at the rear of the mill (on both sides) to tighten or loosen the power feed chain.

50



CAUTION! Do not overtighten the feed chain. Damage to the power feed drive may result.

See Figure 4-4.

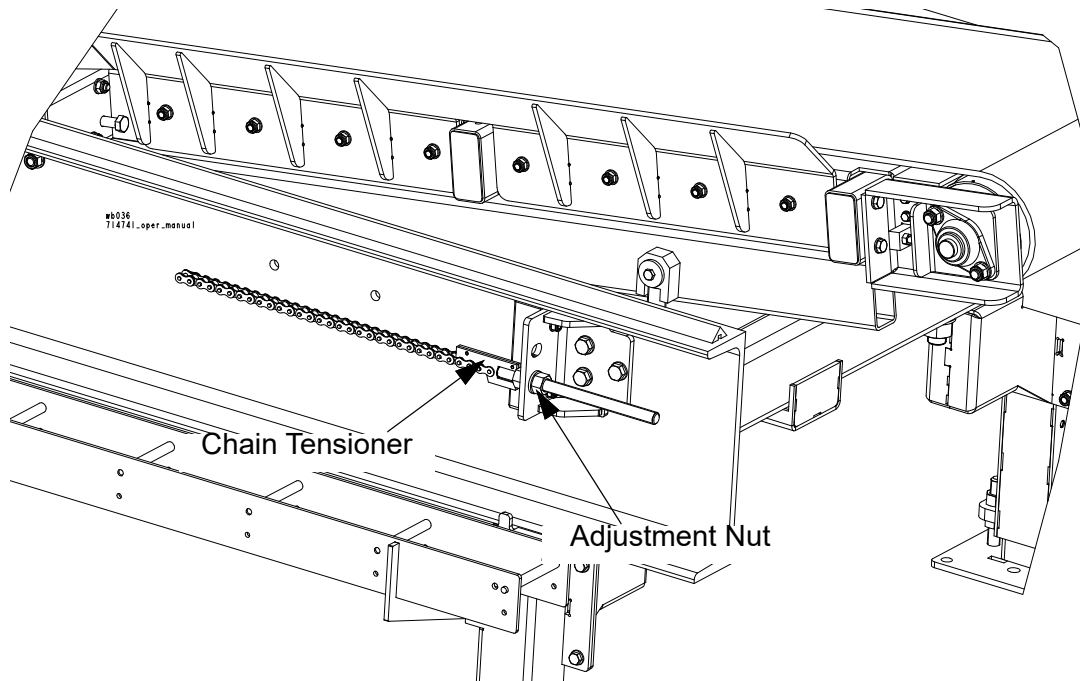

FIG. 4-4.

See Figure 4-5. Adjust the chain until the distance between the chain in its lowest position is about 10mm above the chain support.

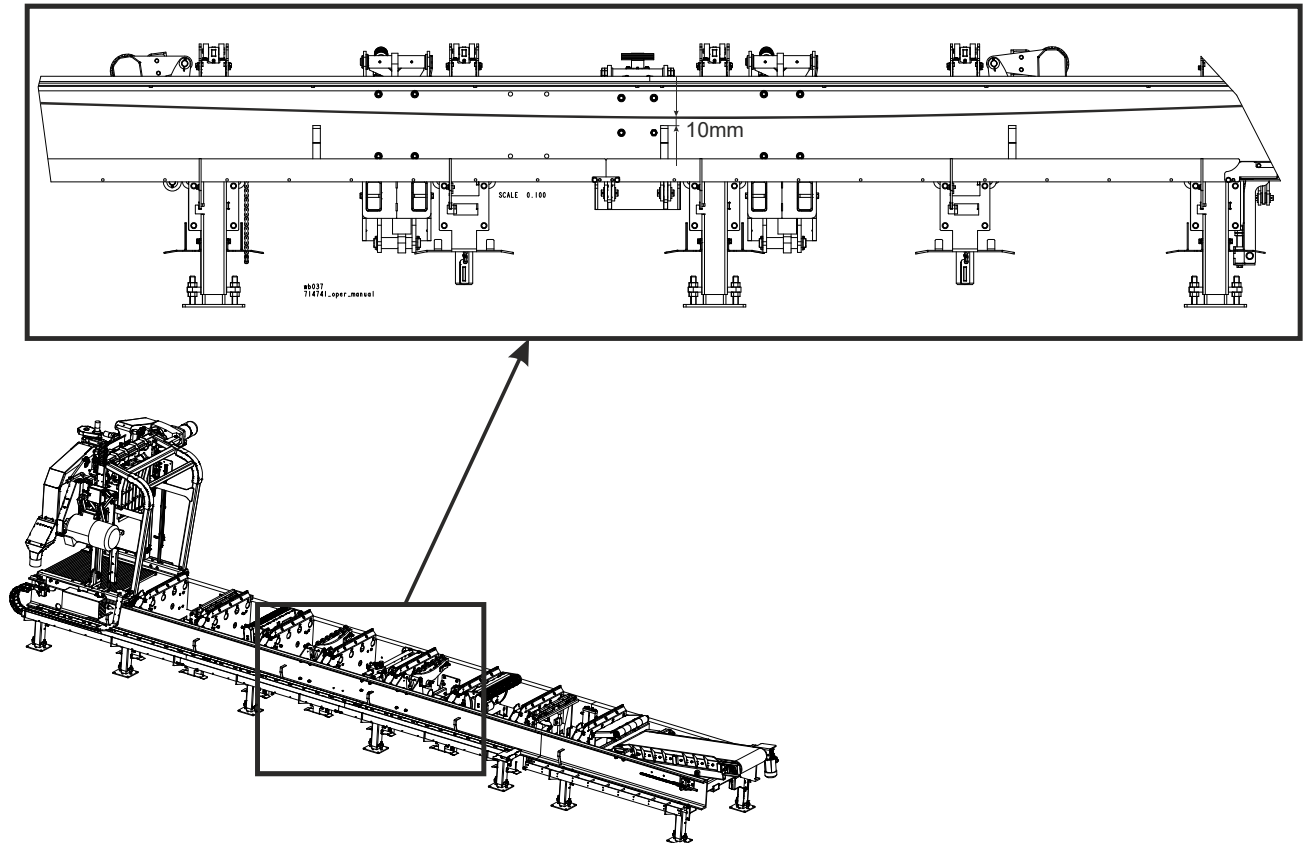

FIG. 4-5.

2. Lubricate the feed chain with a Dexron III ATF oil every fifty hours of operation.

50



CAUTION! Do not lubricate the chain with a grease. It causes sawdust buildup in chain links.

3. Inspect the power feed drive system for worn sprockets, chain links, etc. every 500 hours of operation. Replace or repair components as necessary.

500

4.4 Belt Conveyor Alignment



The belt conveyor is factory-aligned. Periodically check and realign the conveyor belt if necessary. Make sure the belt remains centered on the drive roller and idle wing pulley while running. If the conveyor belt keeps travelling to the side of the drive roller and/or idle wing pulley, follow the alignment procedure below.

To align the conveyor belt:

4. Loosen the jam nuts on one or both idle wing pulley adjustment bolts.

See Figure 4-6.

See Figure 4-6.

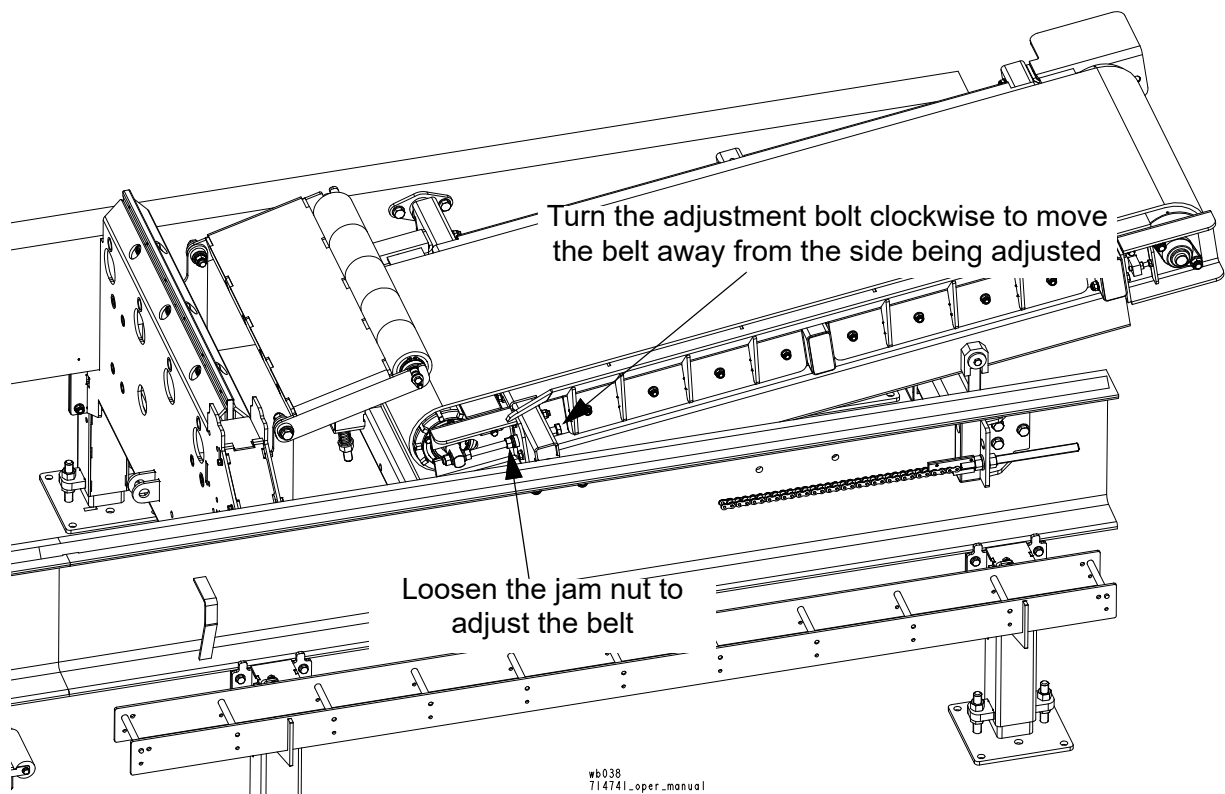

FIG. 4-6.

5. Turn one of the adjustment bolts clockwise to move the idle wing pulley downward and away from the side being adjusted. Turn the adjusted bolt counterclockwise to move the idle wing pulley upward.
6. Start the drive roller motor and check if the conveyor belt still needs to be aligned. Repeat the adjustment procedure until the conveyor belt stays in place on the drive roller and idle wing pulley while running.
7. Tighten the jam nuts when the belt alignment procedure is complete.



Periodically check the conveyor belt for wear. Replace the belt if damaged or worn. Always check the conveyor belt alignment after installing a new belt. Align the conveyor belt after replacing if necessary.

4.5 Safety Devices Inspection

WB2000 – Safety Devices Inspection

Safety devices on the WB2000 machine which must be checked before every shift:

- E-STOP button and its circuit
- Control circuits with the E-STOP button pressed
- Blade cover safety switch #1 and its circuit
- Blade cover safety switch #2 and its circuit
- Motor brake and its circuit

1. E-STOP button and its circuit inspection

- Turn on the blade motor;
- Press the E-STOP button located on the left side of the control box. The blade motor should be stopped. Pressing the START button should not start the motor until the E-STOP button is released.

2. Inspection of the control circuits with the E-STOP button pressed

- Turn on the blade motor;
- Press the E-STOP button located on the left side of the control box. The blade motor should be stopped.
- With the E-STOP button pressed, try to move the saw head up and down using the switch and the Networks buttons, and forward/backward using the power feed switch. Both systems should not start.
- With the E-STOP button pressed, try to start the debarker blade motor and move the debarker arm in and out. The debarker should not work.
- With the E-STOP button pressed, try to move the blade guide arm in and out. The blade guide arm should not work.
- With the E-STOP button pressed, try to start the board return system. The board return system should not work.

3. Blade cover safety switch #1 and its circuit inspection

- Turn on the blade motor;
- Open the blade housing cover #1;
- The blade motor should be stopped;
- Try to start the motor. The blade motor should remain stopped;
- Close the blade housing cover #1;

- The blade motor should remain stopped until it is restarted with the START button.

4. Blade cover safety switch #2 and its circuit inspection

- Turn on the blade motor;
- Open the blade housing cover #2;
- The blade motor should be stopped;
- Try to start the motor. The blade motor should remain stopped;
- Close the blade housing cover #2;
- The blade motor should remain stopped until it is restarted with the START button.

5. Motor brake and its circuit inspection

- Turn on the blade motor. Stop the motor using the STOP button. Measure the braking time.
- Turn on the blade motor. Stop the motor by switching the key to the “0” position. Measure the braking time.
- Turn on the blade motor. Stop the motor by switching the key to the “2” position. Measure the braking time.
- The braking time should always be shorter than 10 seconds. If the braking time is longer, it is necessary to adjust or replace the motor disk brake. See your motor option manual.

6. Mode selection inspection.

- Install and tension the blade.
- Open the blade cover.
- Set the key switch to “H” position (see below).
- It should be possible to spin the blade wheels by hand.

7. Operator seat safety switch and its circuit

- Turn on the blade motor;
- Rise from operator seat;
- The blade motor should be stopped;
- Try to start the motor. The blade motor should remain stopped;
- Sit down on the operator seat. The blade motor should remain stopped;
- Try to start the motor. The blade motor should be started.

SECTION 5 ALIGNMENT

5.1 Bed Frame

5.1.1 *Level the Bed Frame Lengthwise*

Place a level on the frame channel. Use the leg adjustment bolts to level the frame in the direction of the frame length.

See Figure 5-1

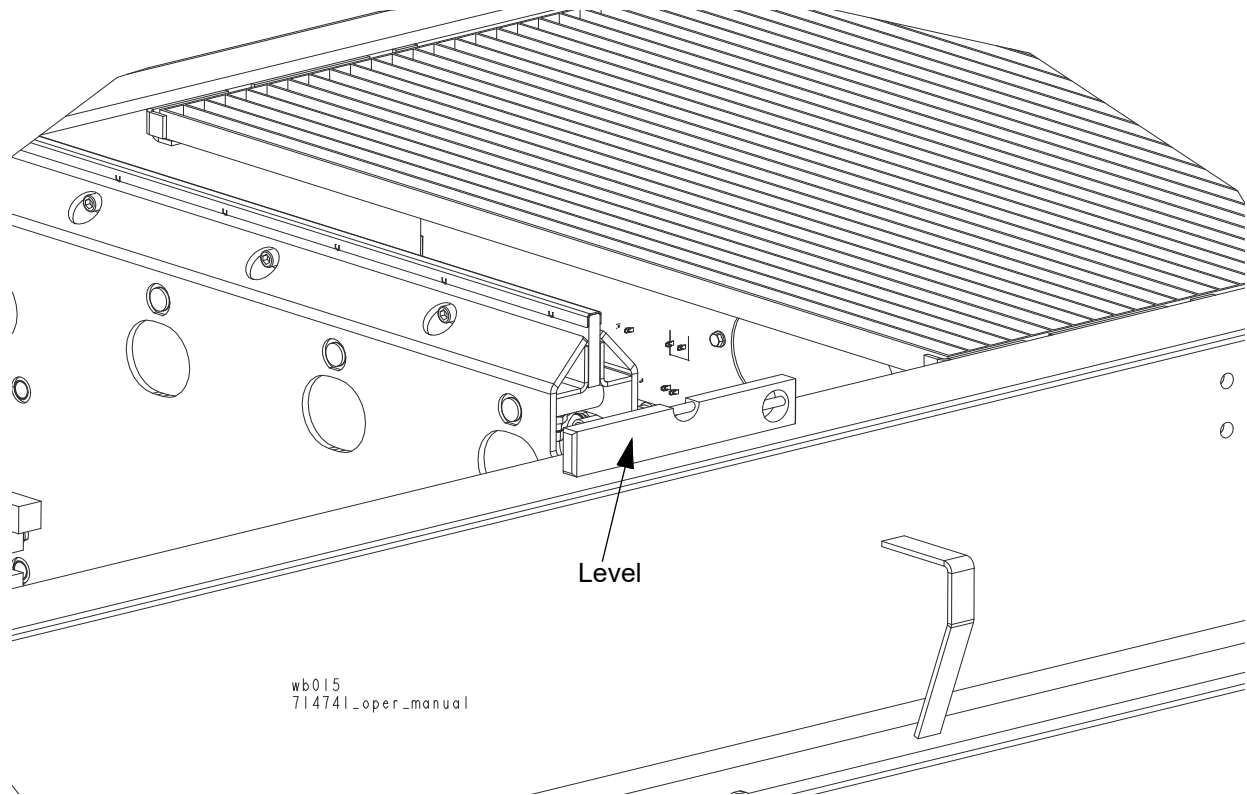

FIG. 5-1

5

Alignment

Level the Bed Frame in a Cross Direction

5.1.2 Level the Bed Frame in a Cross Direction

See Figure 5-2 To level the bed in the cross direction, place the level on the rod of the log clamp. Use the leg adjustment bolts to level the frame in the cross direction.

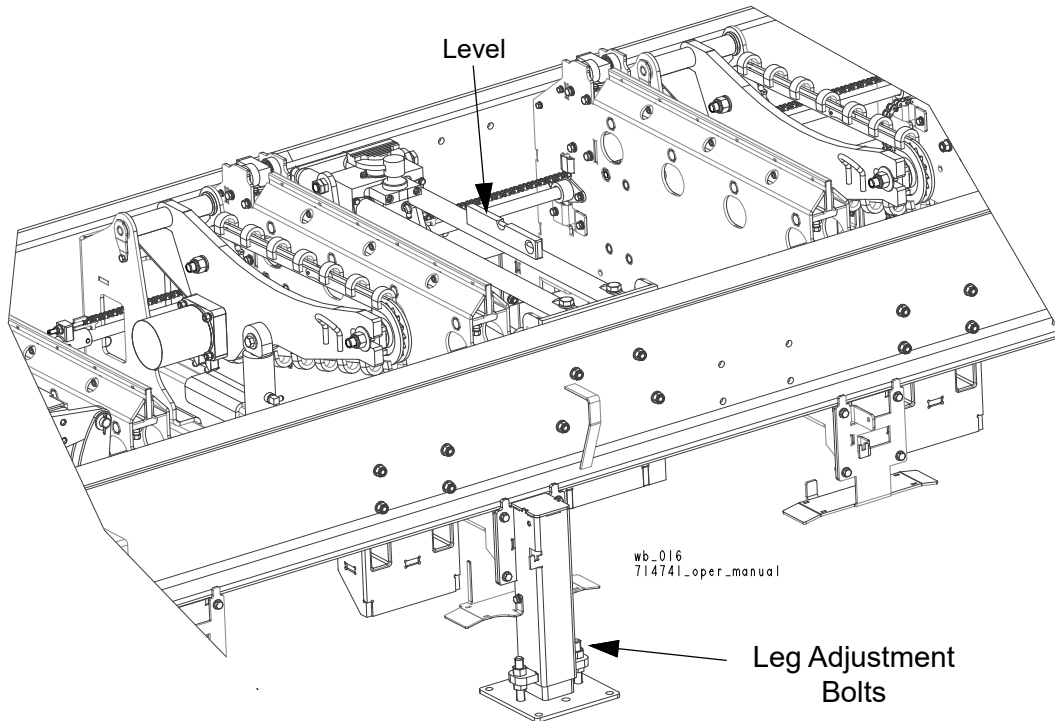

FIG. 5-2

5.1.3 Level the Mast

The saw head mast must be leveled in the horizontal plane. To do this, place the level on the mast tubes as shown below. If the mast is not leveled, use the mast adjustment bolts. Their location is marked with blue circles below.

See Figure 5-3

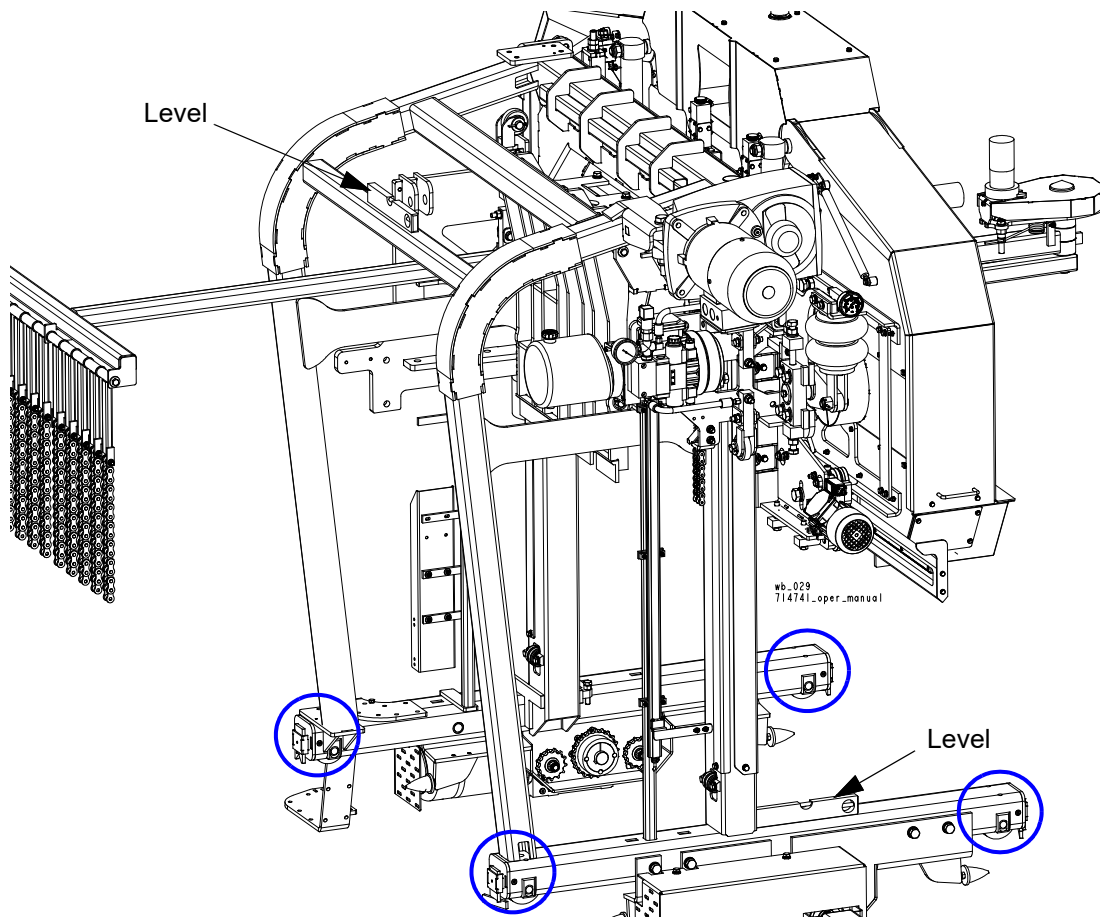

FIG. 5-3

See Figure 5-4 Remove the mounting screws and dismount the scraper brackets (4).

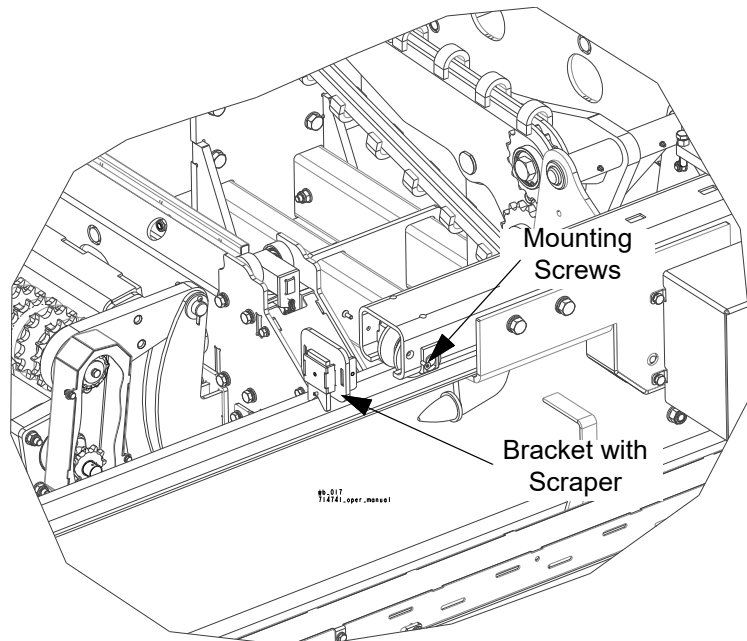

FIG. 5-4

See Figure 5-5 Use the adjustment bolt of the mast rollers to level the mast. Adjust the bolts on each roller evenly.

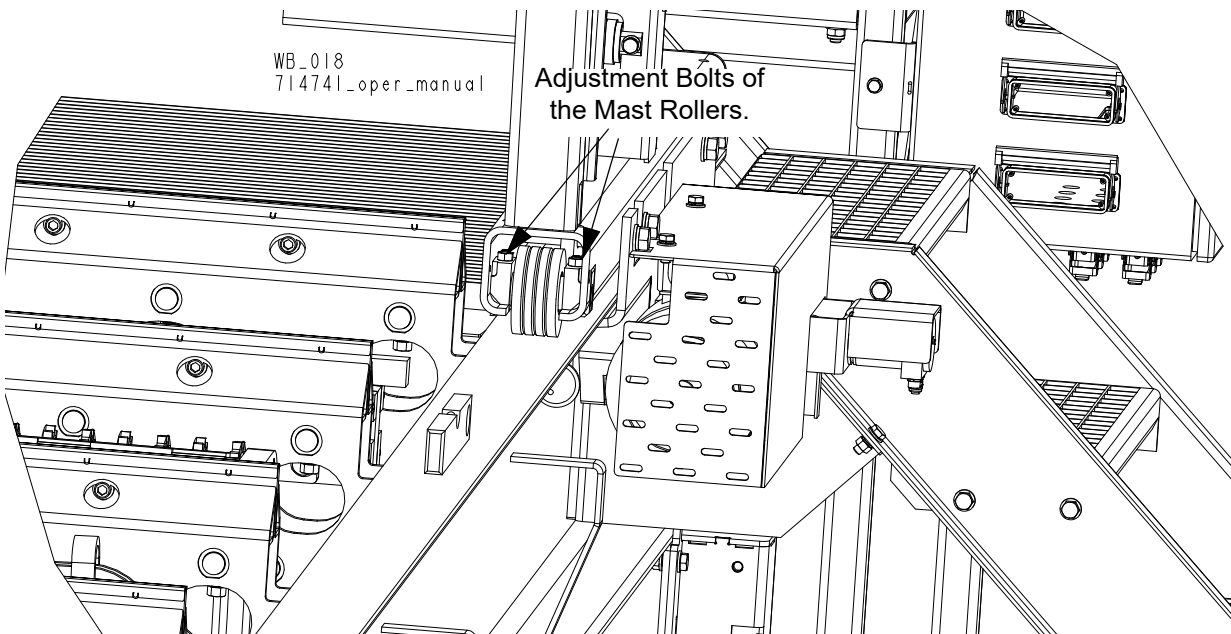

FIG. 5-5

5.1.4 Adjustment of the Bed Rails

Position the saw head over the front bed rail (from the belt conveyor side). Measure the distance from the bed rail to the blade, near the left (A) and right (B) blade guides. The measurements should be the same.

See Figure 5-6 To adjust the bed rail, loosen the locking bolts. Then, using the adjustment bolts, adjust the bed rail so the measurements A and B are the same. The distance between the bed rail and cant stop should not be larger than 18mm. When the adjustment is done, tighten the locking nuts.

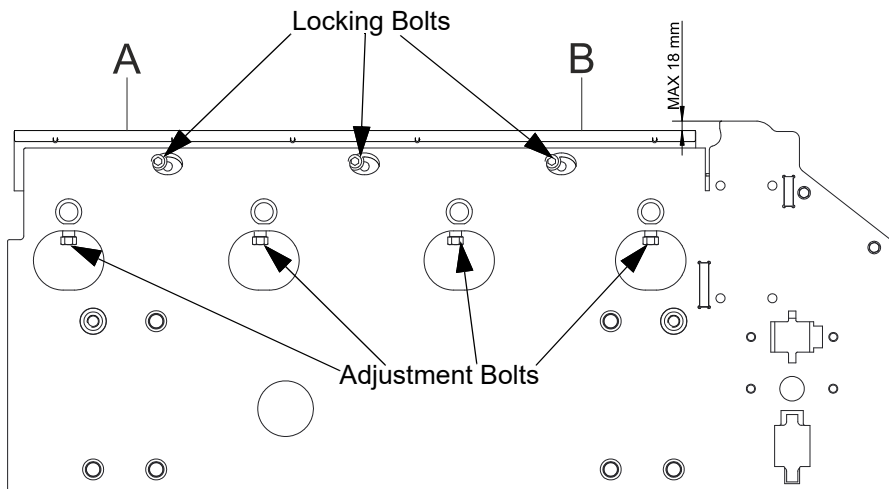

FIG. 5-6

Move the saw head over the last bed rail. Adjust the last bed rail so the distances from the blade to the last bed rail are the same. Then attach a rope to the first and last bed rails.

5

Alignment *Adjustment of the Bed Rails*

See Figure 5-7 Adjust the remaining bed rails so they touch the rope.

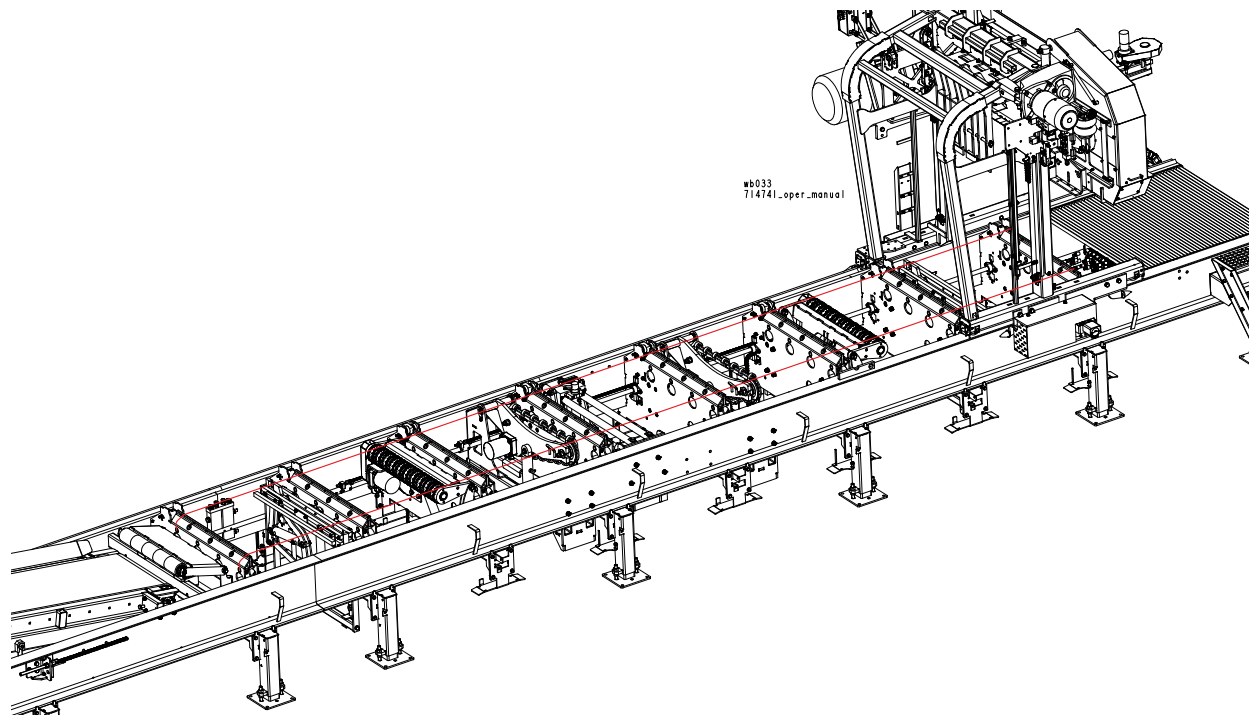

FIG. 5-7

5.1.5 Adjustment of the Side Supports

Adjust the side supports so they stop at the upper and lower limits at the same moment.

See Figure 5-8 To adjust the side support, use the adjustment nuts shown below. Adjust both chains evenly so they do not have slack.

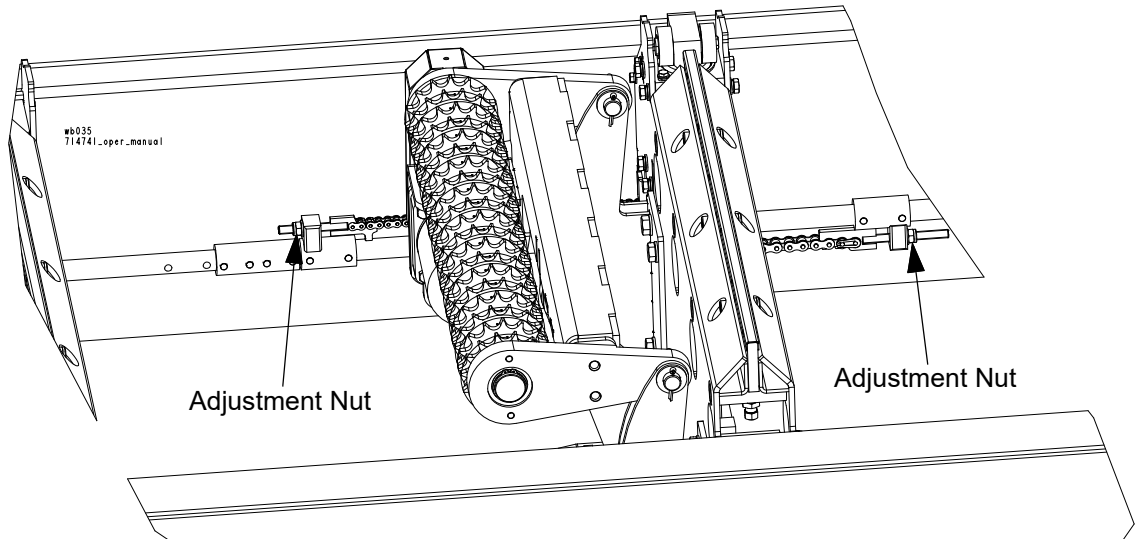

FIG. 5-8

5.2 Sawmill Head

5.2.1 Level the Saw Head

Install a blade and apply the appropriate tension as shown in [Section 3.6](#).

See Figure 5-9 Make sure the blade guide blocks do not touch the blade. Position the saw head over the log clamp. Measure the distance from the rod of the blade clamp near the left (A) and right (B) blade guides. The measurements should be the same. If not, it is necessary to adjust the saw head tilt.

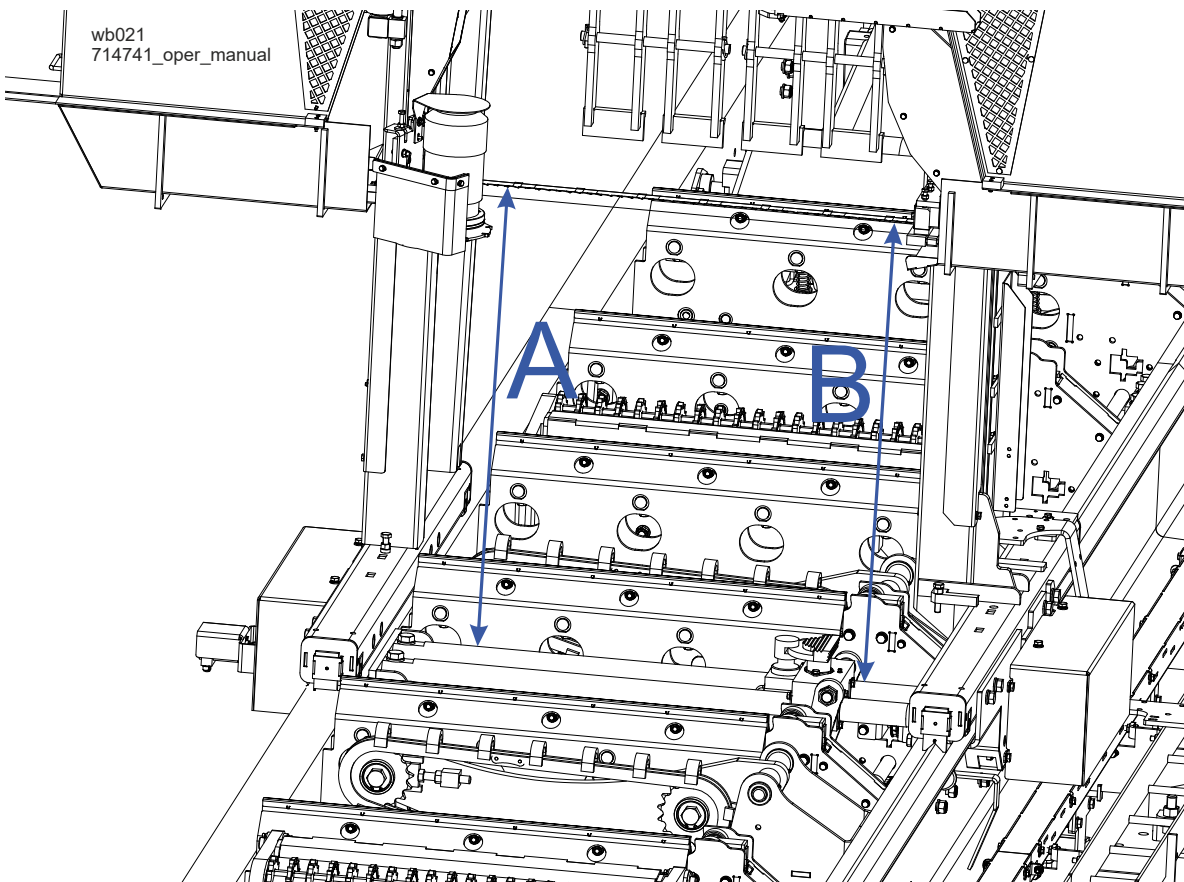

FIG. 5-9

See Figure 5-10 Use the adjustment bolt of the up-down system chains to level the saw head.

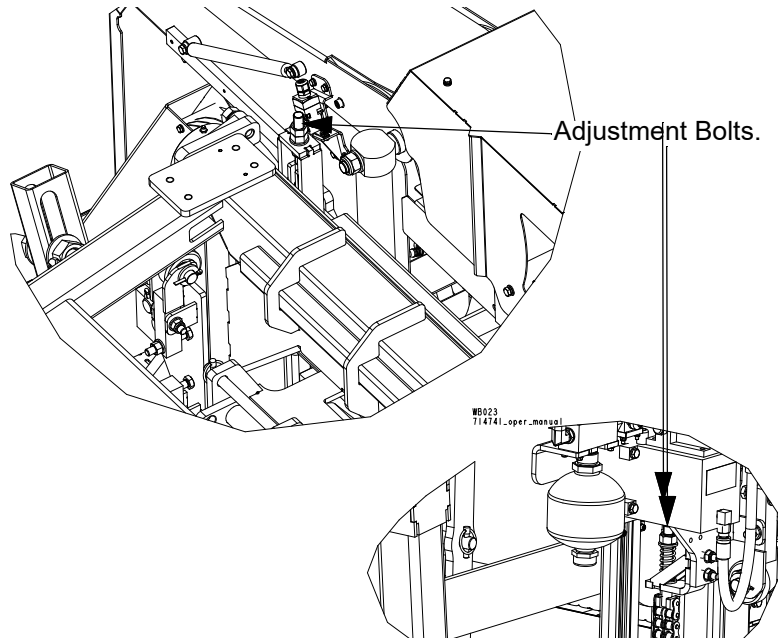

FIG. 5-10

5.2.2 Rollers of the Up-Down System

See Figure 5-11 Check if each of the six up-down rollers touches the mast. Use the adjustment bolts if necessary.

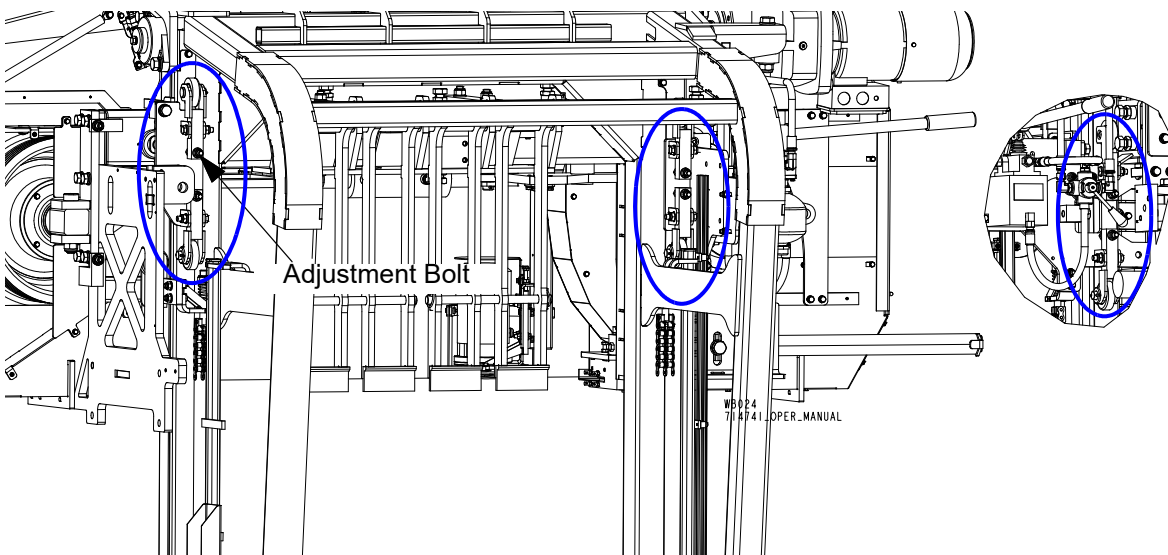

FIG. 5-11

5.2.3 Adjustment of the Blade Wheels

The blade wheels should be adjusted so they are level in the vertical and horizontal planes. If the blade wheels are tilted up or down, the blade will want to travel in the tilted direction. If the blade wheels are tilted horizontally, the blade will not track properly on the wheels.

1. Set the blade guide arm all the way out. Be sure the blade guide blocks do not deflect the blade. Use the blade guide alignment tool to check the vertical alignment of idle blade wheel. Attach the tool to the blade near the idle blade wheel. Be sure the tool does not rest on a tooth or burr, and is lying flat against the bottom of the blade.

See Figure 5-12

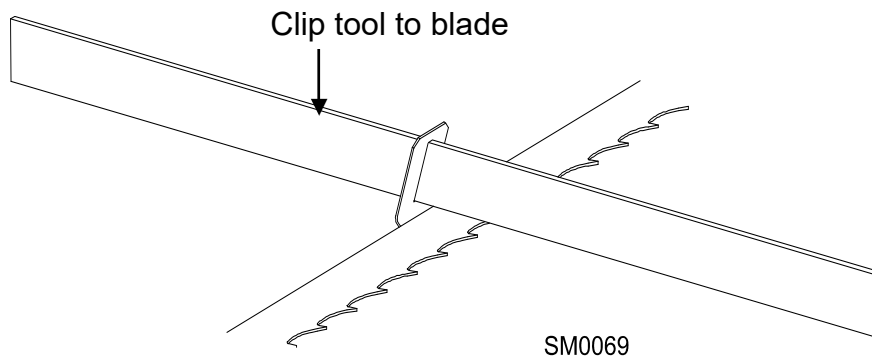

FIG. 5-12

2. Choose a reference point on the floor or bed frame.
3. Move the saw head so the front end of the tool is positioned over the reference point. Measure the distance from the bottom of the tool to the reference point.

4. Move the saw head so the rear of the tool is positioned over the reference point. Measure the distance from the bottom of the tool to the reference point.

See Figure 5-13 If the two measurements differ by more than 1.5 mm (1/16"), adjust the vertical tilt of the idle-side blade wheel. Open the cover of the the idle side wheel. Use the vertical adjustment bolts to adjust the idle-side blade wheel.

To tilt the wheel down, loosen the horizontal adjustment bolt and lock nuts. Then loosen the top vertical adjustment bolt one quarter turn. Loosen the lock nut on the bottom vertical adjustment bolt and tighten the bolt. Tighten the top and bottom lock nuts and horizontal adjustment bolt.

To tilt the wheel up, loosen the horizontal adjustment bolt and lock nuts. Then loosen the bottom vertical adjustment bolt one quarter turn. Loosen the lock nut on the top vertical adjustment bolt and tighten the bolt. Tighten the top and bottom lock nuts and horizontal adjustment bolt. Close the cover of the the idle side wheel.

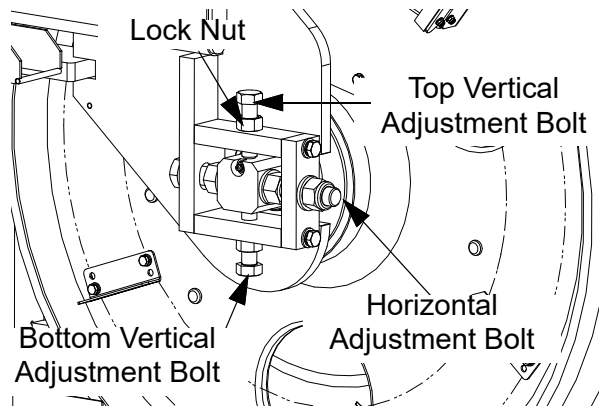

FIG. 5-13 IDLE SIDE WHEEL VERTICAL ADJUSTMENT

5. Recheck the vertical tilt of the idle-side blade wheel with the blade guide alignment tool. Readjust the blade wheel as necessary until the front and rear of the tool are the same distance from the reference point (1.5mm) (1/16").

5

Alignment

Adjustment of the Blade Wheels

6. Check the position of the blade on the idle-side and drive-side blade wheels. Open the cover of the drive-side and idle-side wheels. Turn the key switch to the "H" position (If the machine is equipped with a motor brake). Carefully spin one of the blade wheels by hand until the blade positions itself on them.

See Figure 5-14 The horizontal tilt of the blade wheel should be adjusted so that the gullet of a 3" (75 mm) and 4" blade (75 mm) is 3-4 mm (0.12"-0.16") out from the front edge of the wheel. Do not let the teeth ride on the wheels.

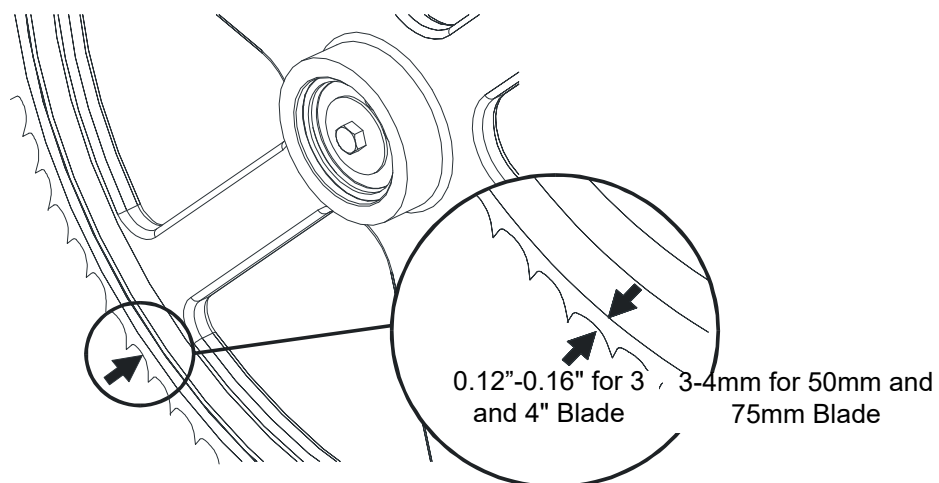

FIG. 5-14

See Figure 5-15 Use the nuts of the horizontal adjustment bolt to adjust the drive-side blade wheel. To move the blade back on the wheel, turn the right nut counterclockwise and the left nut clockwise on the adjustment bolt.

To move the blade out on the wheel, turn the right nut clockwise and the left nut counterclockwise on the adjustment bolt. After finishing the adjustment, close the saw head side covers.

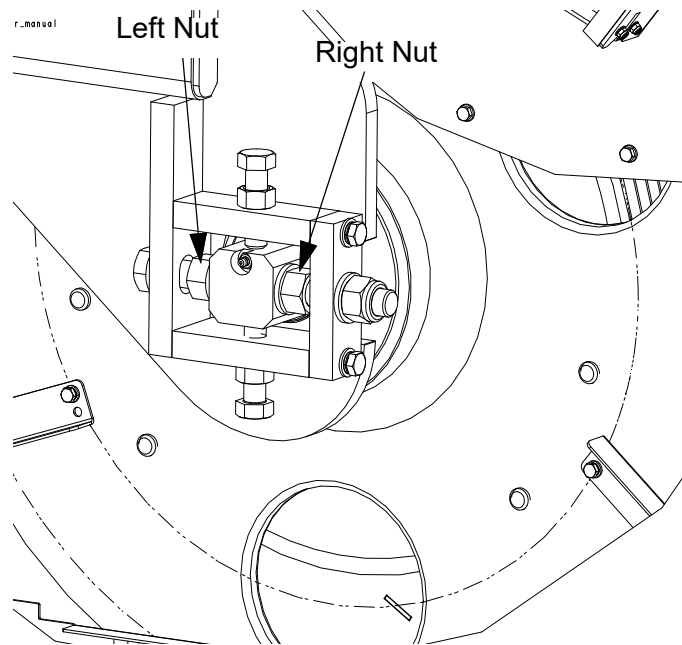

FIG. 5-15

5 Alignment

Adjustment of the Blade Wheels

If the blade is not in line between idle and drive blade wheels, adjust idle-blade wheel.

See Figure 5-16

- To move the idle blade wheel horizontally loosen bolts “A” and use nuts “B”. After adjustment tighten bolts “A”.

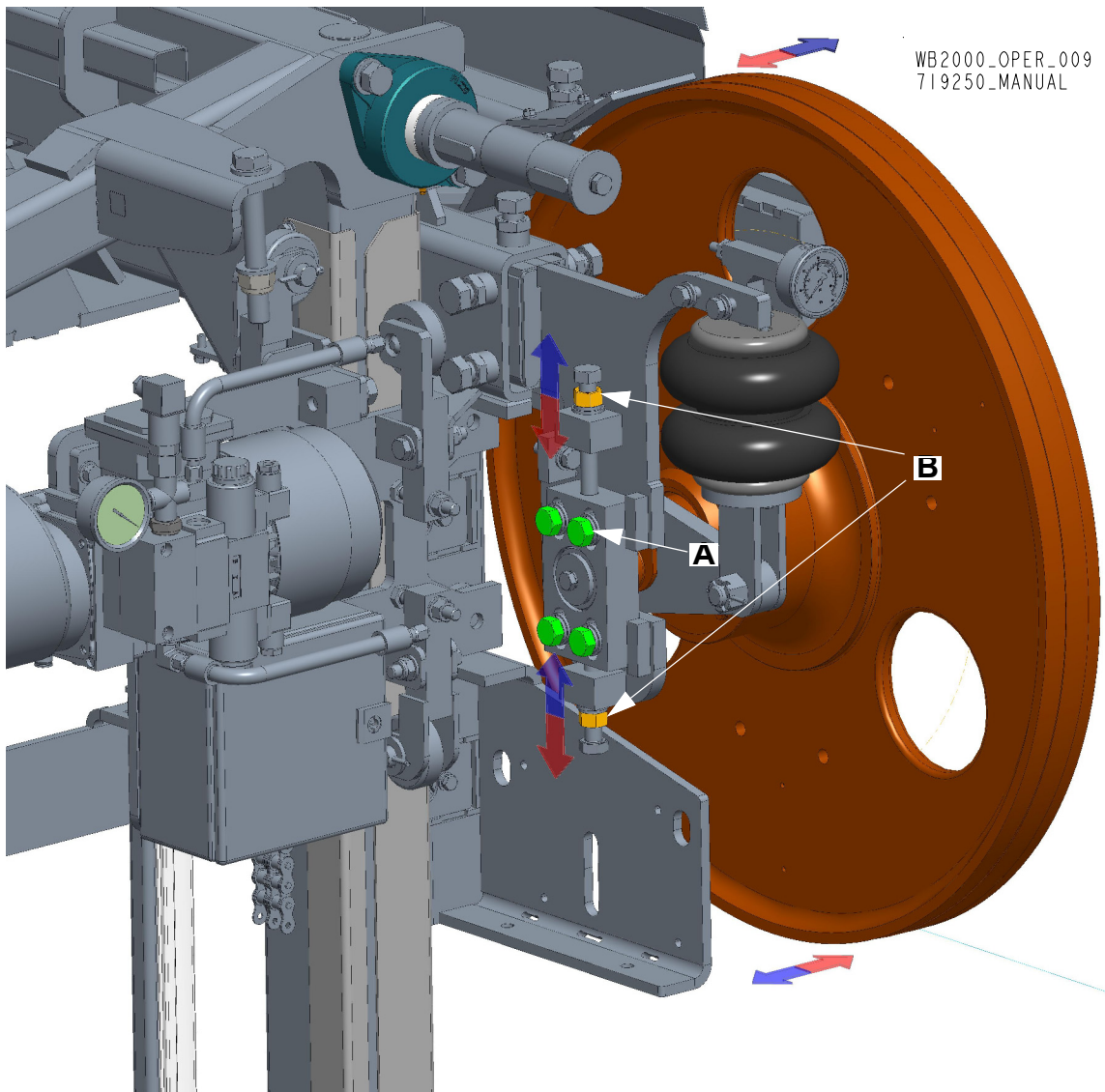

FIG. 5-16

See Figure 5-17

- To move the idle blade wheel vertically loosen bolts “A” and use nut “B”. After adjustment tighten bolts “A”.

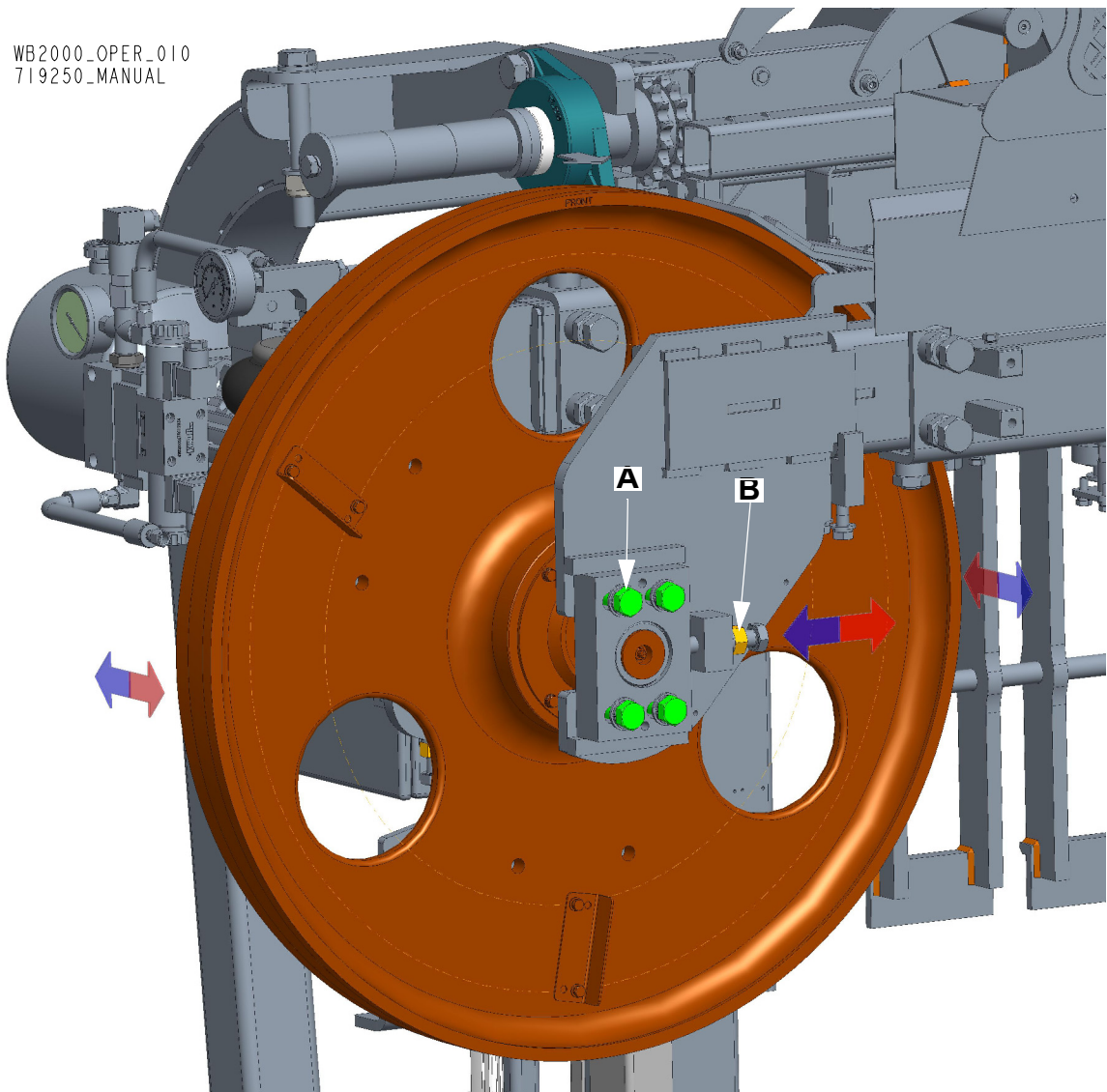

FIG. 5-17

7. After adjusting the blade wheels, always check the drive belt tension and blade tension. Close the cover of the the drive-side and idle-side wheels. Start the blade motor for a few seconds at full r.p.m. Stop the motor, open the blade wheel covers and recheck the adjustment of blade wheels, drive belt tension and blade tension.

5.2.4 Drive Belt Adjustment



WARNING! Do not for any reason adjust the drive belts with the motor running. Doing so may result in serious injury.

After changing the drive belts to the new ones check the drive belt tension every 8h in first two days and every 2 months thereafter or every time is needed (vibrations, noise)

Execute drive belt tension procedure for every drive belt.

To adjust the drive belt tension:

See Figure 5-18:

- Remove the drive belts cover.

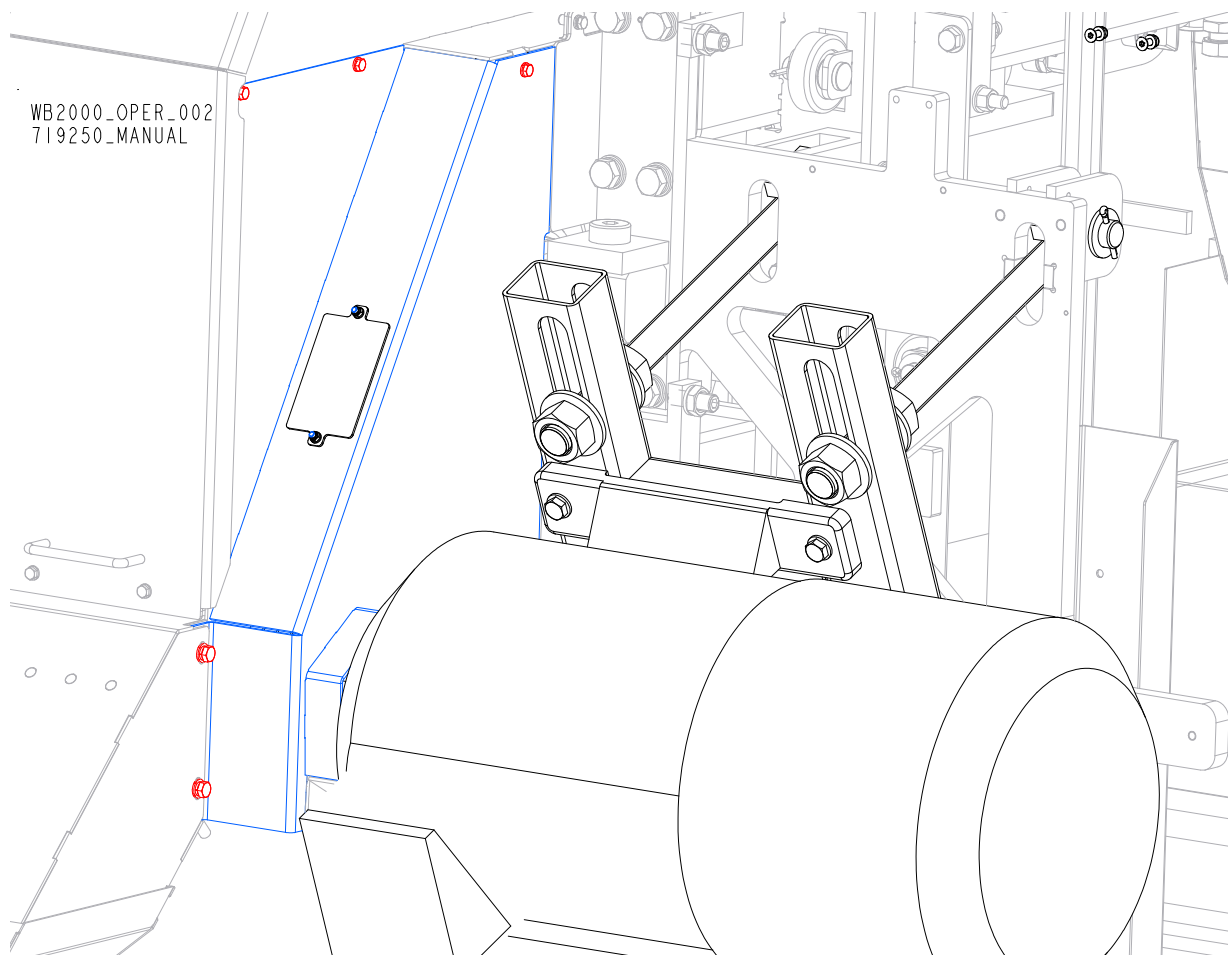

FIG. 5-18

See Figure 5-19:

- Use fasteners (A) to align drive belts tension

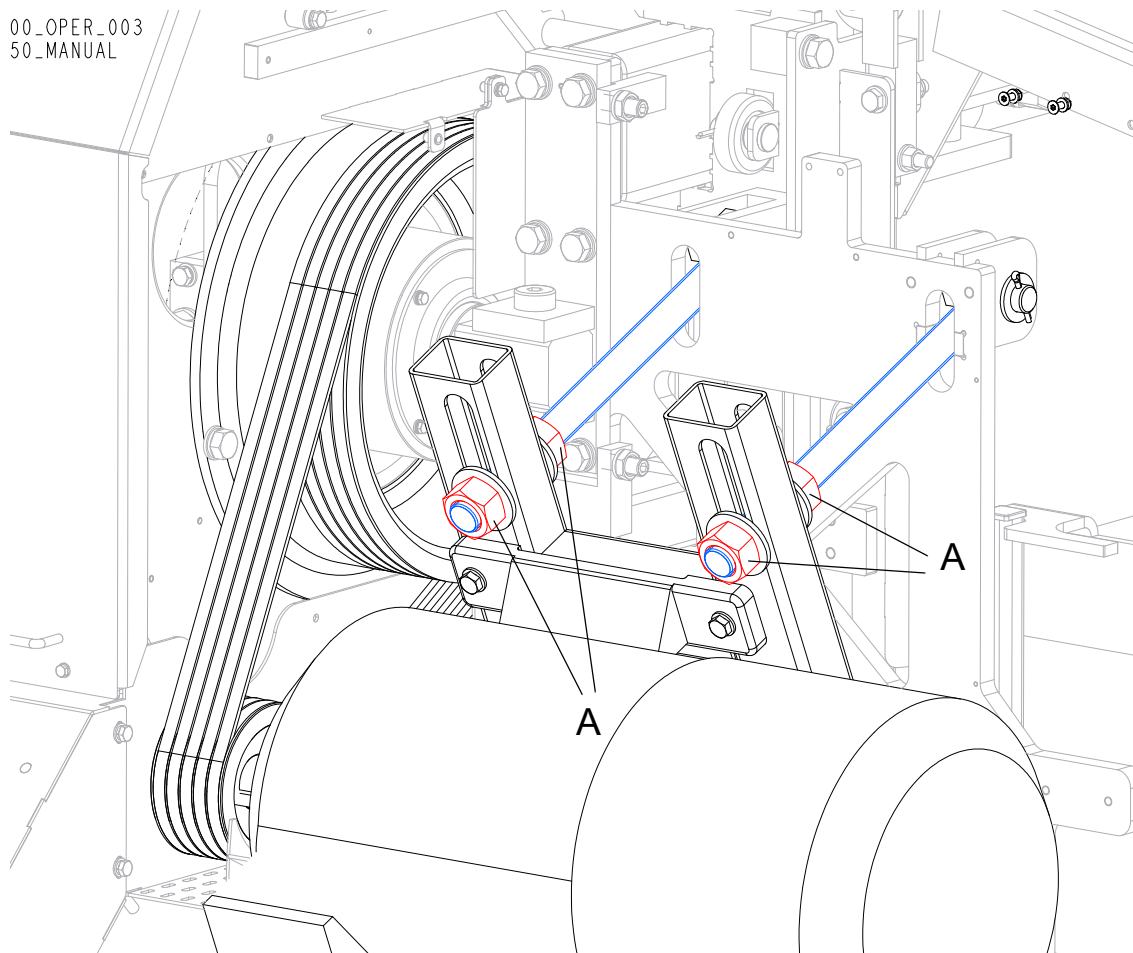

FIG. 5-19

5

Alignment

Drive Belt Adjustment

See Figure 5-20:

See Table 5-1. See the table below for drive belt tension specifications.

Belt Wear	Belt Tension
New Belt	0.35" (9mm) deflection with 14 lbs. (6.5 kg) of deflection force (F)
Used Belt	0.35" (9mm) deflection with 13 lbs. (6 kg) of deflection force (F)

TABLE 5-1.

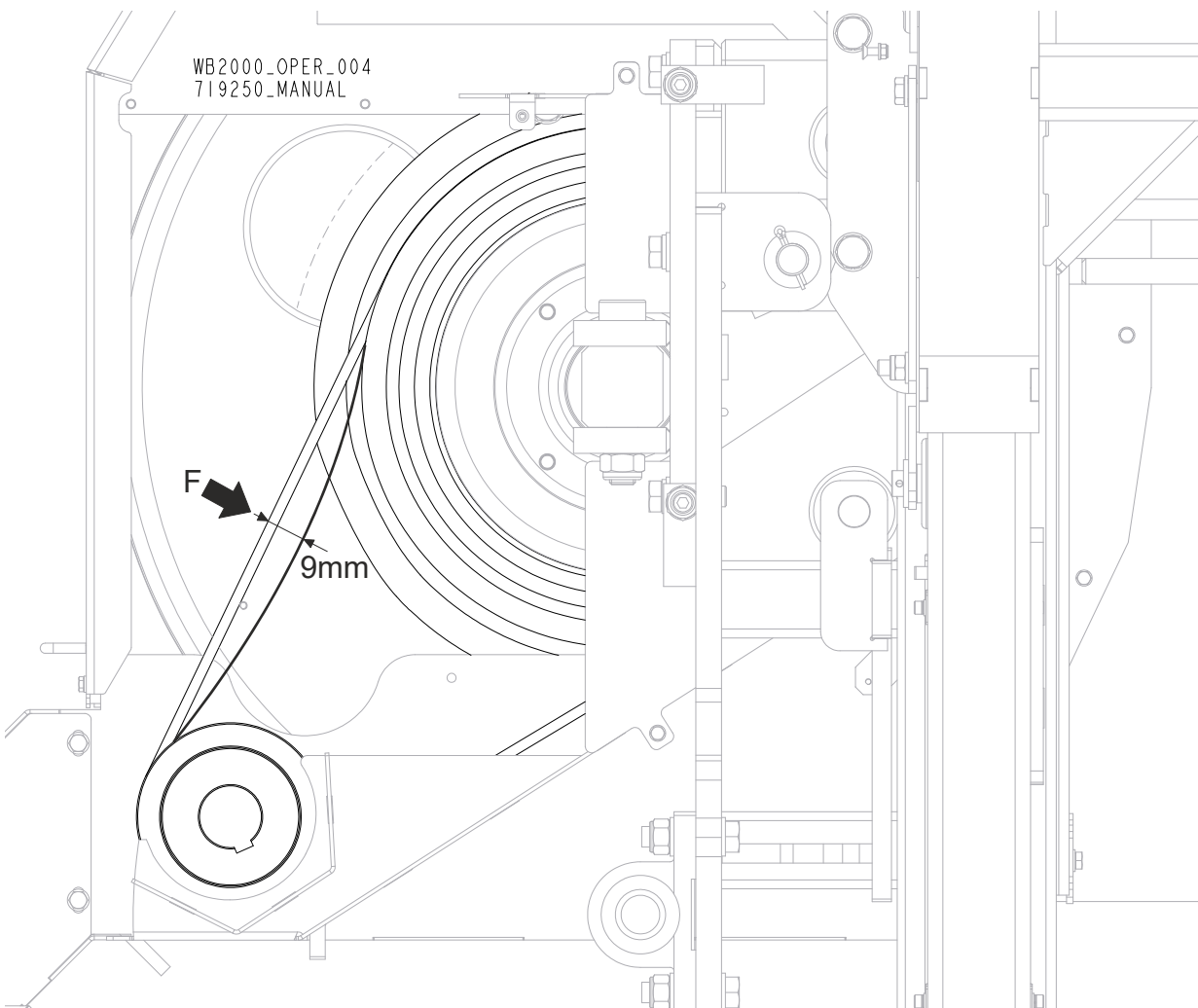

FIG. 5-20

- Mount the drive belts cover.
- Periodically check the belts for wear. Replace if the belt is damaged or worn.

5.3 Adjustment Of The Roller Blade Guide (718859)

See Figure 5-21 Adjust the blade guide arm fully open. Measure the distance between the back edge of the blade guide bracket and the back of the blade. Next, adjust the blade guide arm all the way in toward the inner blade guide assembly. Measure the distance again.

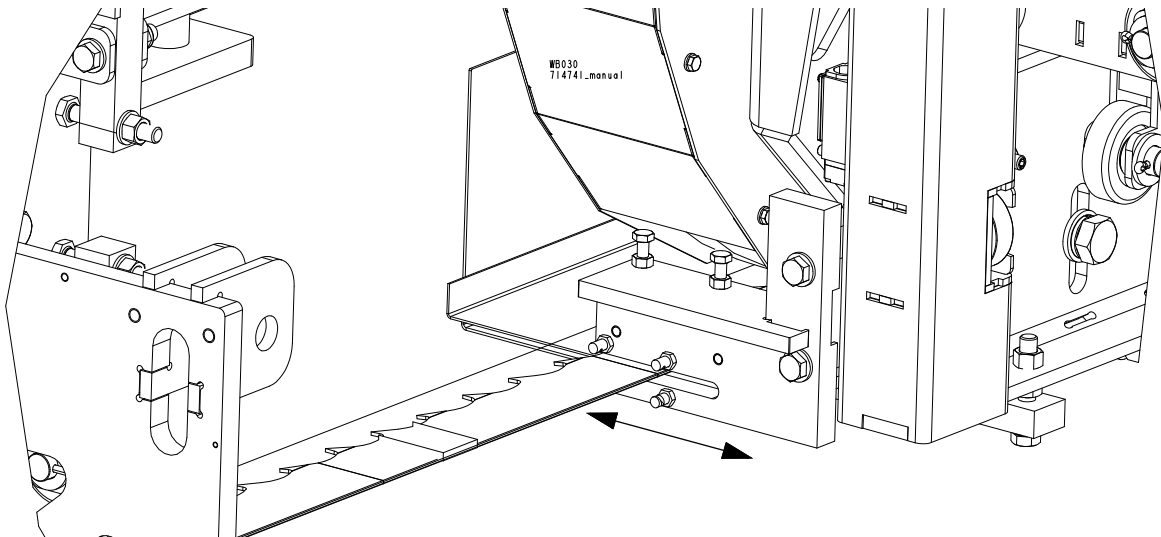

FIG. 5-21

The two measurements should be the same. If not, adjust the blade guide arm in the horizontal plane.

See Figure 5-22 Loosen the horizontal adjustment bolt jam nuts. To tilt the arm towards the blade, loosen the right bolt and tighten the left bolt. To tilt the arm away from the blade, loosen the left bolt and tighten the right bolt. Re-tighten the jam nuts and recheck the blade guide arm horizontal tilt.

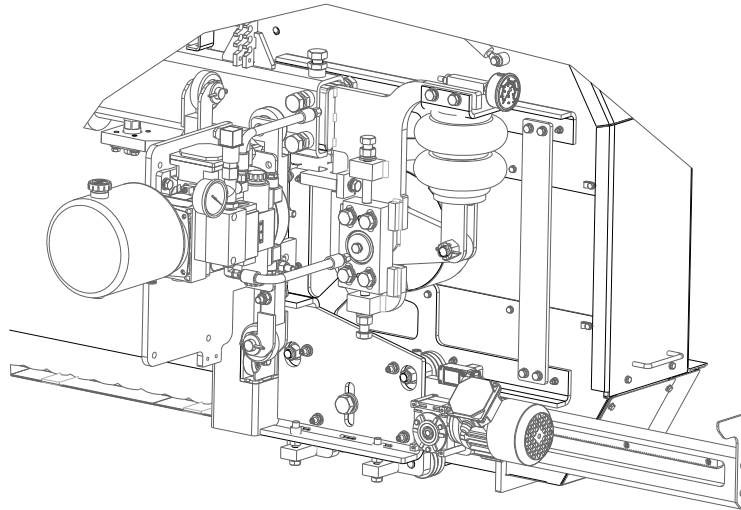

FIG. 5-22

The blade guides should deflect the blade from 1mm (for 75mm blade) to 2mm (for 100mm blade).

Be sure the blade guide blocks do not touch the blade. Position the saw head over the log clamp. Measure the distances from the rod of the blade clamp to the blade near the left and the right blade guides.

See Figure 5-23 Loosen the mounting bolts of the upper blocks. Using the adjustment bolts, adjust the upper blocks of the blade guide so they deflect the blade 1-2mm (the distance from the rod to the blade in both positions should be smaller than 1-2mm). Tighten the mounting bolts of the upper blocks. Then loosen the mounting bolts of the bottom blocks. Adjust the bottom block of the blade guide so it slightly touches the blade. Then tighten the mounting bolts.

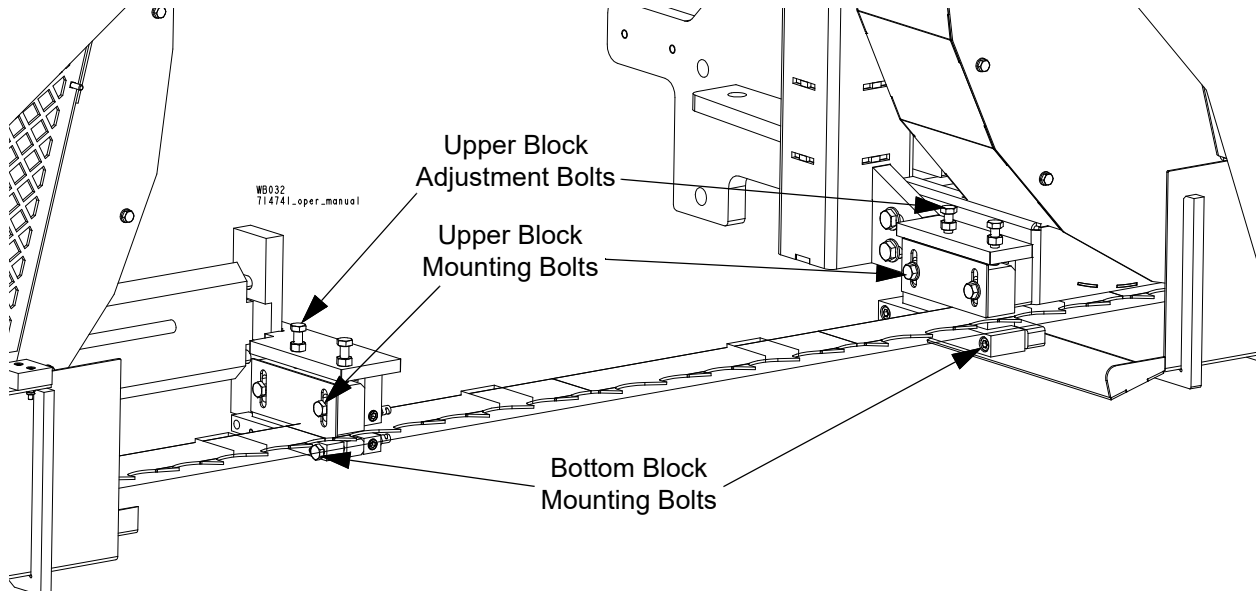

FIG. 5-23

5.4. Blade Deflection

Perform the following steps to achieve proper blade deflection with the blade guides:

1. Position the saw head so that the blade is above a bed rail. Measure the actual distance with a tape from the top of the rail to the bottom of the blade.
2. Loosen the bottom bolts M8x25 (A) next loosen the bolts M8x35 (B), adjust the bolt M8x40 (C) until the blade guide deflects the blade down 6 mm. Finally, turn the bolts (B) and (A).

See Figure 5-24

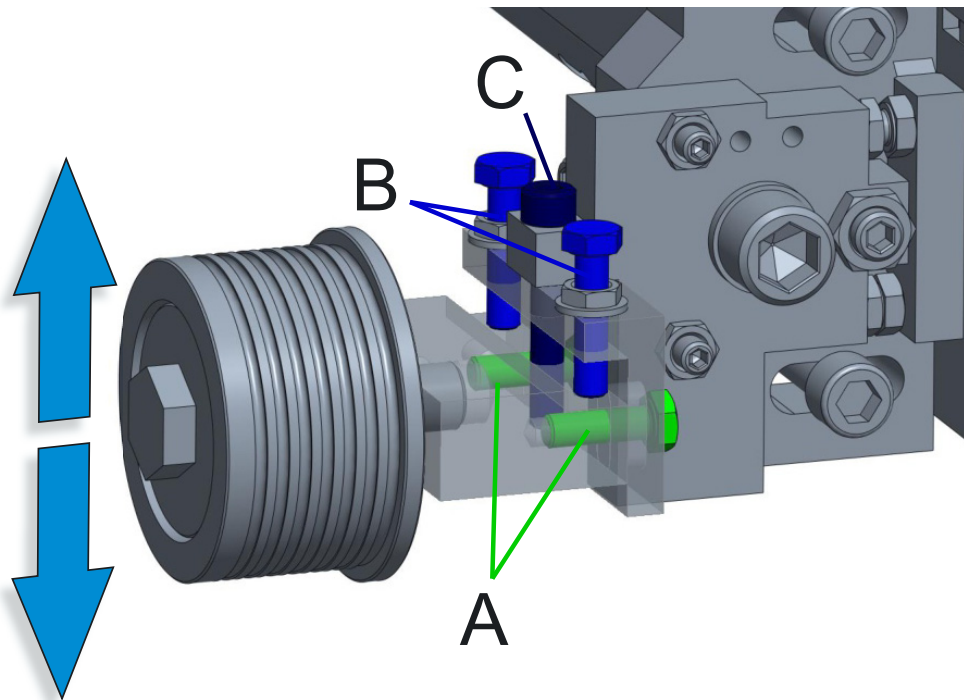

FIG. 5-24

3. Repeat for the other blade guide. Loosen the nuts M10 (A) next loosen the bolts M8x35 (B), adjust the bolt M8x40 (C). Finally, turn the bolts (B) and nuts (A).

See Figure 5-25

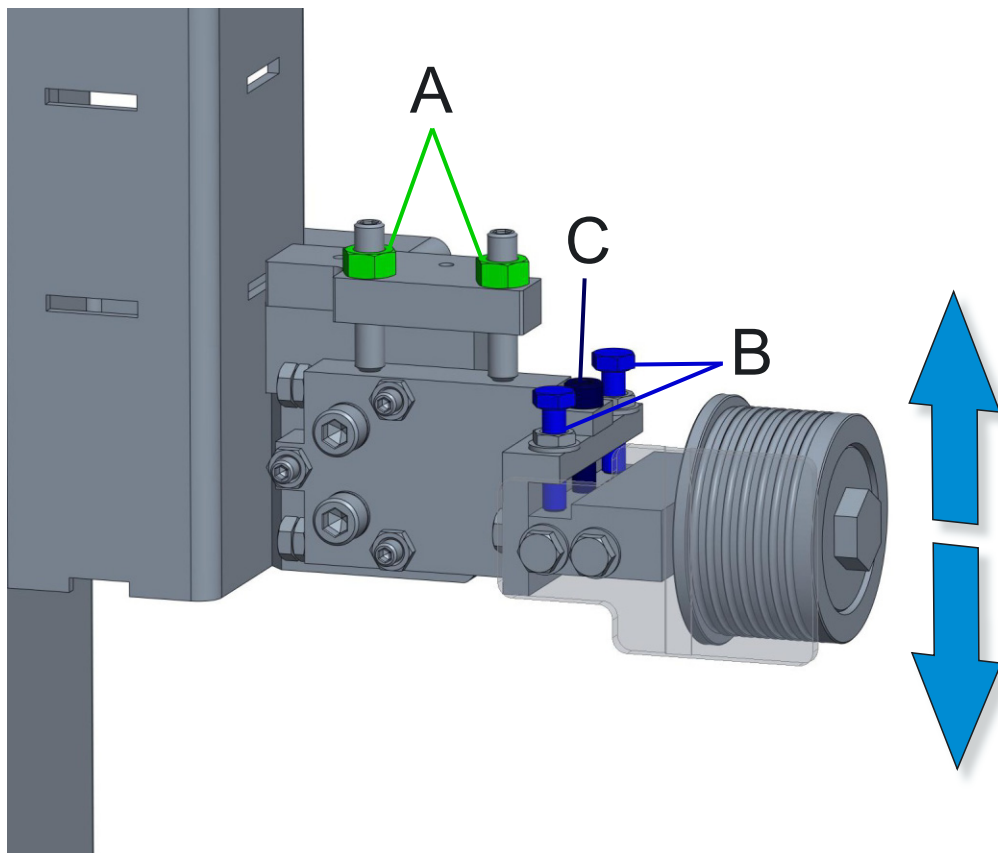

FIG. 5-25

4. **NOTE:** Be sure the blade guard clears the blade. It should be checked with the blade guard all the way in and all the way out.

5.5. Blade Guide Vertical Adjustment

Check that the blade guides does not tilt the blade up or down. A Blade Guide Alignment Tool is provided to help you measure the vertical tilt of the blade.

1. Attach the alignment tool to the blade. Position the tool close to a blade guide roller. Be sure the tool does not rest on a tooth or burr, and is lying flat against the blade..

See Figure 5-26

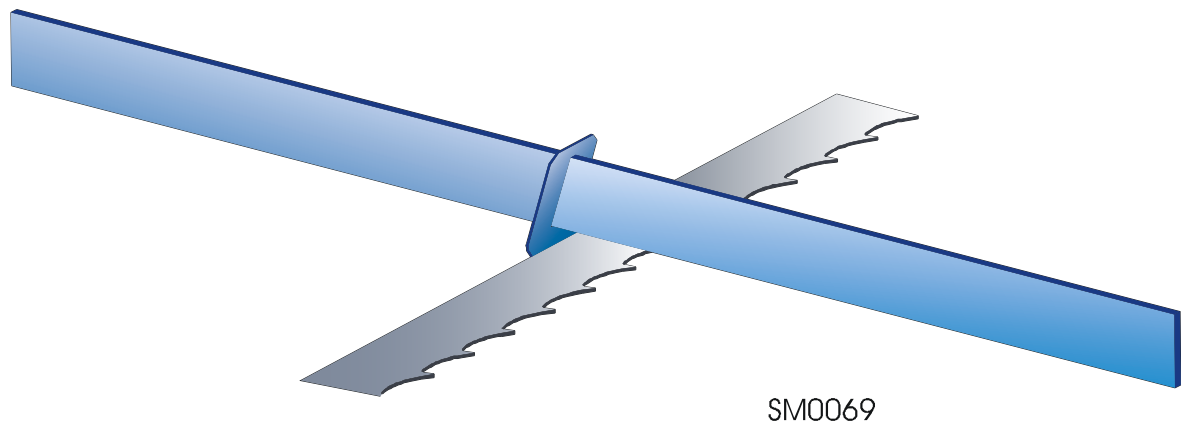

FIG. 5-26

2. Measure the distance from the bottom of the tool to the bed rail.
3. Move the saw head so that the front end of the tool is positioned above the bed rail.
4. Measure again the distance between the tool and bed rail.

See Figure 5-27

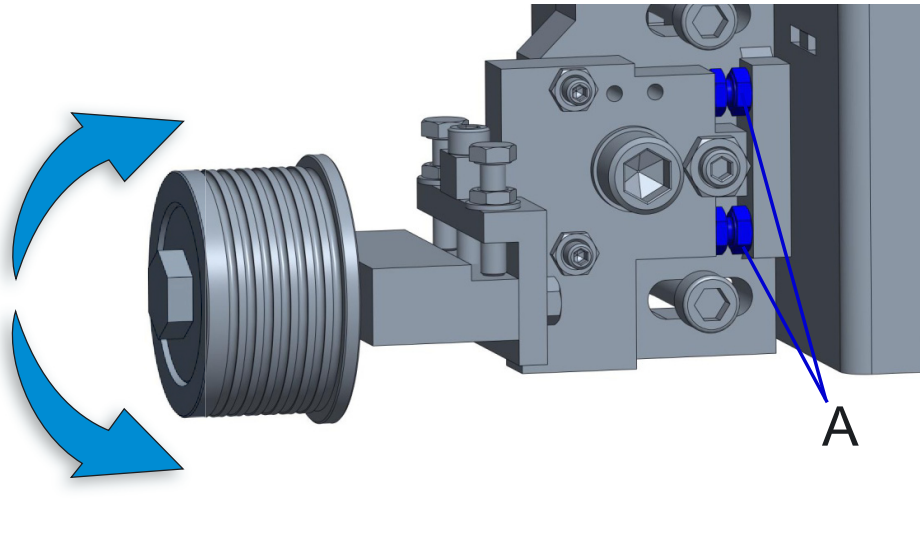

FIG. 5-27

5. The two measurements should be the same. If they are not, adjust the tilt of the roller with the bolts M8x16 (A).
6. Move the saw head in the cutting direction so the back end of the tool is over the bed rail. Measure the distance between the tool and the bed rail.
7. This measurement should equal the two earlier measurements. If it is not the same, adjust the blade guide using the screws shown in the figure above.
8. Move the tool close to the other blade guide and repeat the adjustment procedure described above.

NOTE: If any adjustments to blade guide tilt were made, make sure the blade deflection is correct (6 mm).

NOTE: After adjusting the blade guides, start the blade drive for a moment. Then stop the blade and check again if the blade guides are properly positioned.

5.6. Blade Guide Spacing Adjustment

1. Adjust the blade guide so the blade guide roller flange is approximately 4-5 mm from the back of the blade.

See Figure 5-28

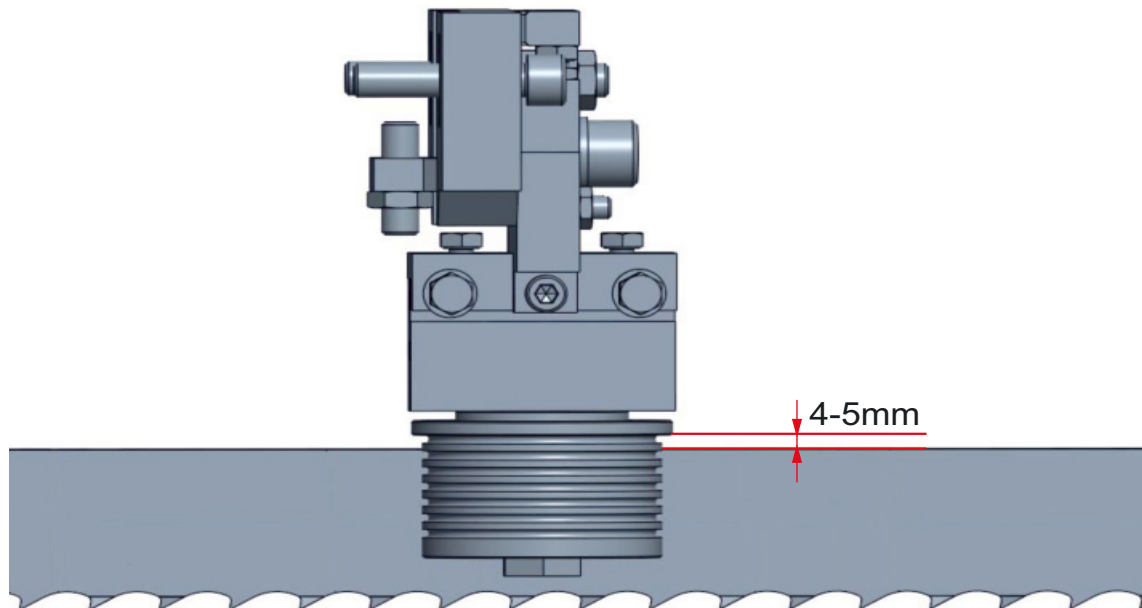

FIG. 5-28

2. Loosen the bolts M12x55 (A) and then adjust the roller with the nut (B). Tap the blade guide forward or backward until properly positioned.

See Figure 5-29

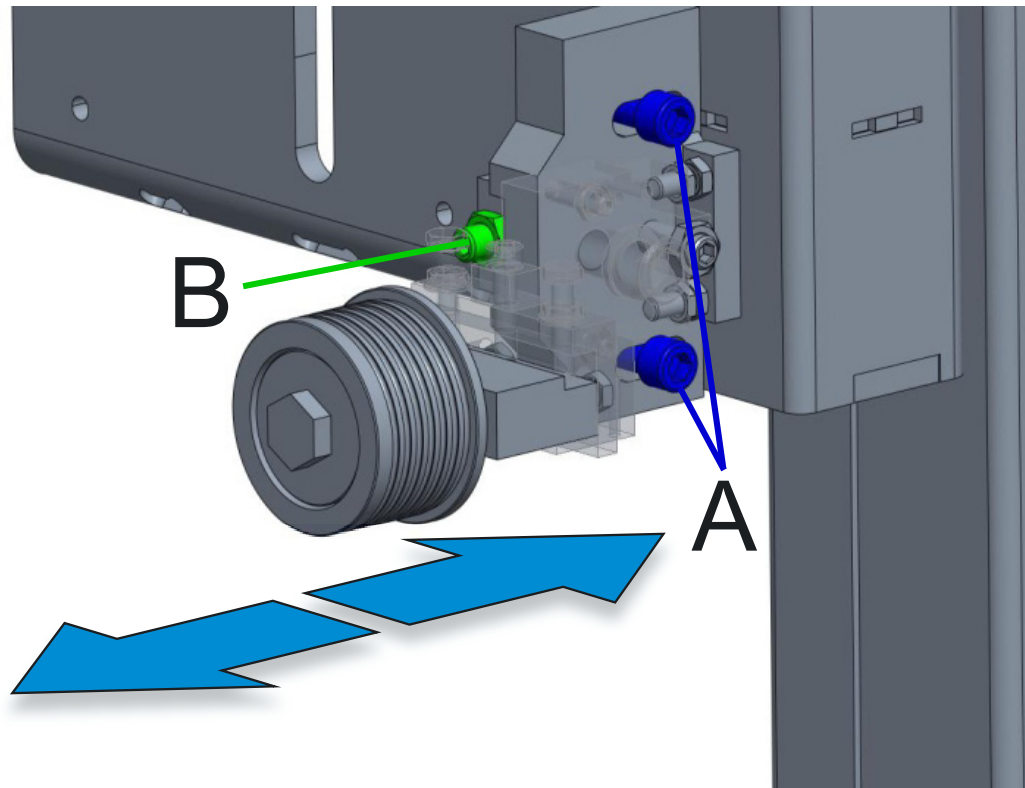

FIG. 5-29

3. Tighten the set screws.
4. Repeat the above adjustment procedure for the other blade guide.

NOTE: After adjusting the blade guide spacing, start the blade drive for a moment. Then stop the blade and recheck the spacing.

5.7. Blade Guide Horizontal Adjustment

See Figure 5-30

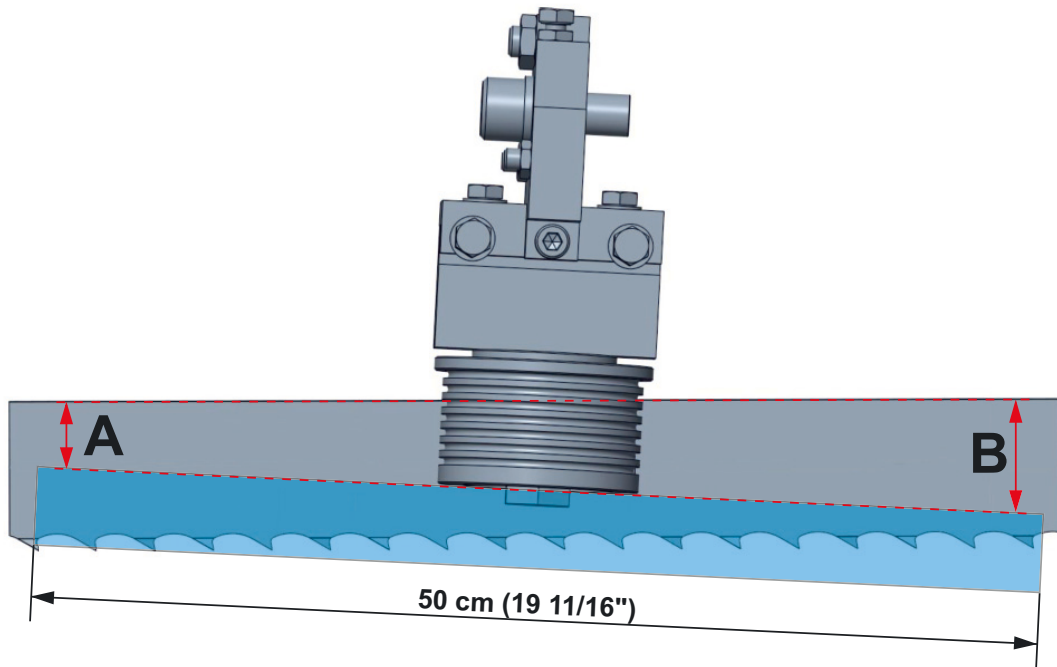

FIG. 5-30

1. Place the Blade Guide Alignment Tool against the face of a blade guide roller and center it on the roller as shown above.
2. Measure between the back edge of the blade and the tool at one end of the tool (A).
3. Measure between the back edge of the blade and the other end of the tool (B).
4. The blade guide roller should be parallel to the blade ($A=B$) or slightly tilted in the horizontal plane ($A=B-3\text{mm}$). If this condition is not met, adjust the roller in the horizontal plane using the side set bolts on the blade guide.

5. To adjust the guide, loosen bolt A and then use bolts B to set it correctly.

See Figure 5-31

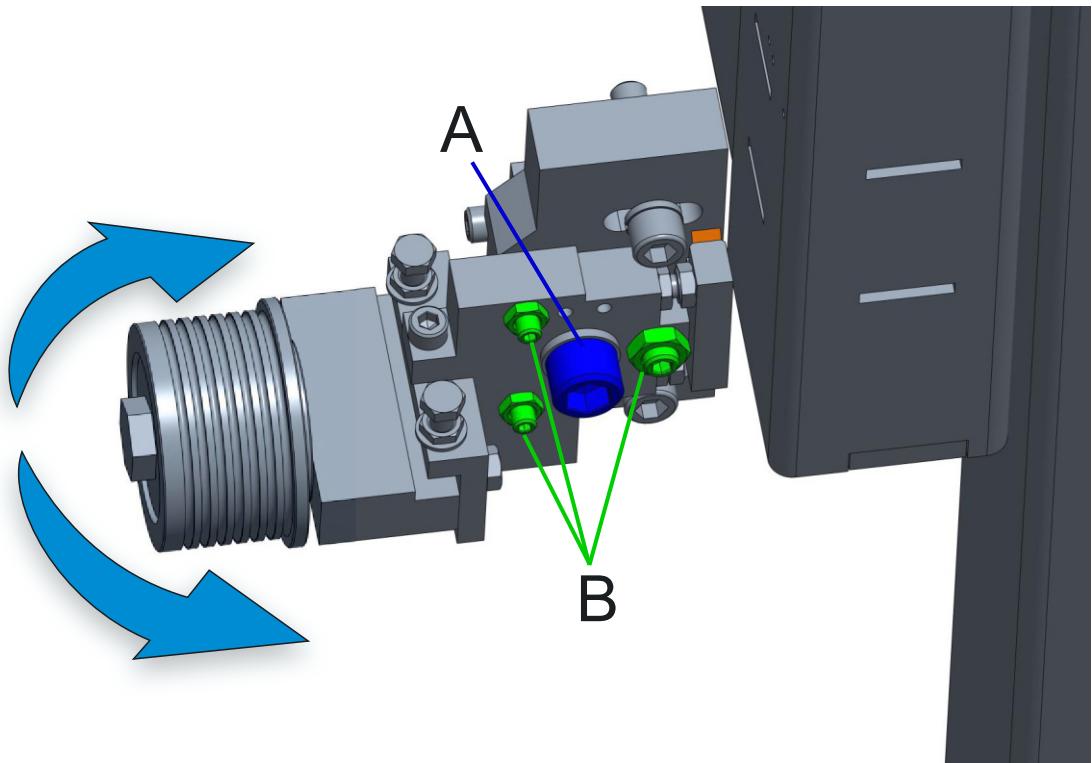

FIG. 5-31

- Repeat the above steps for the other blade guide.

See Figure 5-32

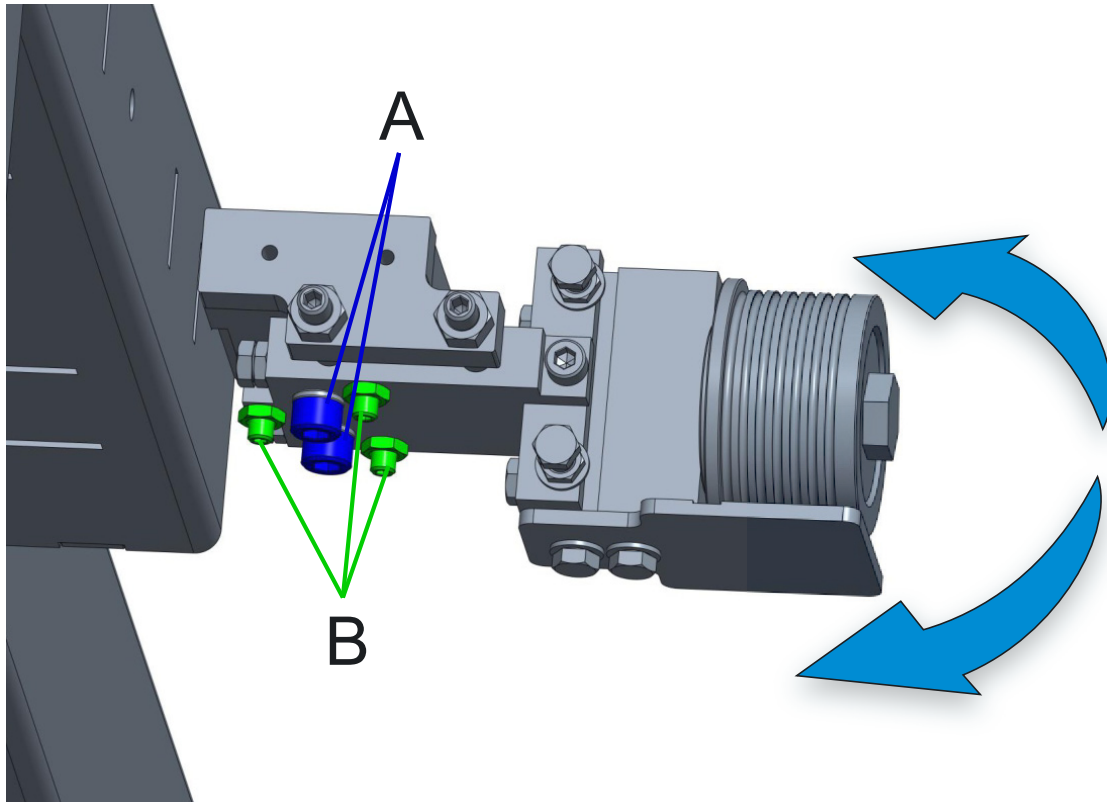

FIG. 5-32

NOTE: Once the blade guides have been adjusted, any cutting variances are most likely caused by the blade.

SECTION 6 SAWMILL SPECIFICATIONS

6.1 Belt Sizes

See Table 6-1. Belt sizes for the WB2000 sawmill are shown below.

Description	Belt Size	Wood-Mizer Part #
Motor Drive Belt	XPA L=1682	713990

TABLE 6-1.

6.2 Blade

See Table 6-2. Blade specifications for the WB2000 sawmill are shown below.

Parameter	Value
Blade Width	75mm (3") 100mm (4")
Blade Length	6000mm 236"
Blade Linear Speed	22-30m/s
Blade Tension System	Hydraulic
Blade Lubrication	Oil only

TABLE 6-2.

See **The Blade Handbook** for blade hook angle, tooth height, and tooth set specifications.

6.3 Cutting Capacity

See Table 6-3. The log size capacities of the WB2000 sawmill are listed below.

Parameter	Value
Min. Log Diameter	200mm ,8"
Max. Log Diameter	1000mm 39"
Min. Log Length	1100mm 43"
Max. Log Length ¹	depends on bed frame length: S-Bed: 5,2m (4,5m with board removal system) S-Bed Eco 4,5m M-Bed: 8,2m (7,5m with board removal system) M-Bed Eco 7,5m

TABLE 6-3.

¹ Each additional bed extension module adds approximately 2016mm or 4032mm to length capacity.

6.4 Motor Specifications

See Table 6-4. The power options available for the WB2000 sawmill are listed below.

Motor Type	Manufacturer	Power	Other Specifications
Electric E40	Siemens	30 kW	59 A, 1465 r.p.m.
Electric E50	Siemens	37 kW	69 A, 1465 r.p.m.

TABLE 6-4.

See Table 6-5. The other motors used in sawmills are listed below.

Motor Type	Power
Up/Down	1.5 kW
Power Feed	2.2 kW
Hydraulic Pump Motor	WB2000: 7,5 kW WB2000 EC: 5,5 kW

TABLE 6-5.

6.5 Noise Level

See Table 6-6. The average noise level is given in the table below¹²³.

Sawmill	Noise Level
WB2000	$L_{EX8} = 93,2 \text{ dB (A)}$

TABLE 6-6.

6.6 Overall Dimensions

See Table 6-7. The overall dimensions of the WB2000 sawmill are listed below.

Sawmill Model	Length	Length with Operator's Station	Width	Height	Weight
WB2000M	11360mm (447")	13456mm (530")	3300mm (130")	3300mm (130")	8000kg 17363 lb
WB2000S	8940mm (352")	11034mm (434")	3300mm (130")	3300mm (130")	6800kg 14991 lb
WB2000M ECO	---	12500mm (492")	3300mm (130")	3300mm (130")	---
WB2000S ECO	---	9756mm (384")	3300mm (130")	3300mm (130")	---

TABLE 6-7.

1. The noise level measurement was taken in accordance with PN-EN ISO 3746 Standard. The noise exposure level given above concerns an 8-hour work day. Value for associated uncertainty $K=4\text{dB}$.
2. The measured values refer to emission levels, not necessarily to noise levels in the workplace. Although there is a relation between emission levels and exposure levels, it is not possible to determine with certainty if preventives are needed or are not needed. The factors affecting a current level of noise exposure during work are inter alia room characteristics and characteristics of other noise sources, e.g. number of machines and machining operations nearby. Also, the permissible exposure level value may vary depending on country. This information enables the machine's user to better identify hazards and a risk.
3. **IMPORTANT!** The total value of hand-arm vibration the operator may be exposed to does not exceed 2.5 m/s^2 . The highest root mean square value of weighted acceleration to which the whole operator's body is subjected does not exceed 0.5 m/s^2 .

6.7 Chains

See Table 6-8. The load capacity of the chains is listed below.

Load Capacity According to ISO Nr 08A-1	
Up/Down Chains	6800 KG

TABLE 6-8.

6.8 Sawdust Extractor Specifications



CAUTION! Always turn on the dust extraction system before starting the machine.



CAUTION! The sawdust extraction system must be grounded or made with materials not accumulating electrostatic charge.

See Table 6-9. See the table below for specifications of the dust extractor ¹.

Maximum Capacity	1200 m ³ /h (1569 yd ³ /h)
Collector Inlet Diameters (in front of fan)	150 mm (5.9 ")
Motor Power	1.5 kW
Number of Sacks for Waste	1 pcs
Total Capacity of Sacks	0,25 m ³ (8.8 ft) ³
Weight	110 kg (242.5 lb)
Pressure drop	1,5 kPa (0.22 psi) ¹
Conveying Speed When 10 m Long Hose Is Used	20 m/s (65.6 ft/s)

TABLE 6-9.

¹ The pressure drop between the inlet of the capture device and the connection to the CADES should be maximum 1.5 kPa (for the nominal air flow rate). If the pressure drop exceeds 1.5 kPa the machine might not be compatible with conventional CADES.

1. External chip and dust extraction equipment with fixed installations are dealt with in EN 12779:2016-04.

6.9 Lube System Specifications

The blade lubricating oil specifications are listed below.

Oil Type	Manufacturer	Freezing Temperature	Ignition Temperature	Autoignition Temperature
ACP-1E ¹	Orlen	-20° C (-4° F ^o)	Above 140° C (284° F)	250° C (482° F)

TABLE 6-10.

¹ Waste oil must be disposed of in compliance with applicable national and local regulations.

6.10 Hydraulic Oil Specifications

The hydraulic oil specifications are listed below.

Oil Type	Manufacturer	Freezing Temperature	Ignition Temperature
MOBILDTE 10 EXCEL 32 ¹	Mobil	-45° C (-49° F ^o)	>210° C (>410° F)

TABLE 6-11.

¹ Waste oil must be disposed of in compliance with applicable national and local regulations.



SECTION 7 LASER INFORMATION

LP-520L-10

Industrial hermetic focusable laser line generator with rectilinearity correction.

Laser for industrial applications.

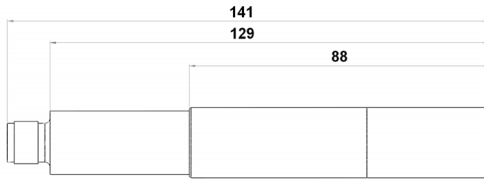

Technical data:

- Safety Class 2M from EN 60825-1:2014;
- Wavelength $\lambda=520\text{nm}$;
- Average Output Power 10mW;
- Operating Voltage 9V \div 28VDC;
- Operating Current <100mA;
- Optics: aspherical acrylic lens F=8mm; NA=0,28; rod lens $\phi 5$;
- Line generating angle $\sim 90^\circ$;
- Possibility to adjust the focus from few cm to several meters (external focus mechanism);
- Dimensions $\Phi 20 \times 130$;
- International Protection Rating IP65;
- Aluminium housing (black anodized);
- Chromed brass mounting M18 x 1;
- Operating temperature: 0 do +60°C;
- Storage temperature: -40 do +85°C;
- Laser diode electrically isolated from housing;
- M12 plug, 4-pin M12 x 1;
- Pin configuration:
 - 1: voltage supply (+)
 - 3: voltage supply (-)



OPTIONS:

- different optical power, wavelength, line generating angle, gaussian or uniform line optics,
- modulation.



RAIFFEISEN BANK POLSKA S.A.
PLN 96 1750 0009 0000 0000 0272 8238, EUR 15 1750 0009 0000 0000 0272 8338
USD 55 1750 0009 0000 0000 0272 8297, CHF 90 1750 0009 0000 0000 0272 8346
NIP PL5260303208, D&B 422320739



HYDRAULIC USA

SECTION 8 HYDRAULIC USA

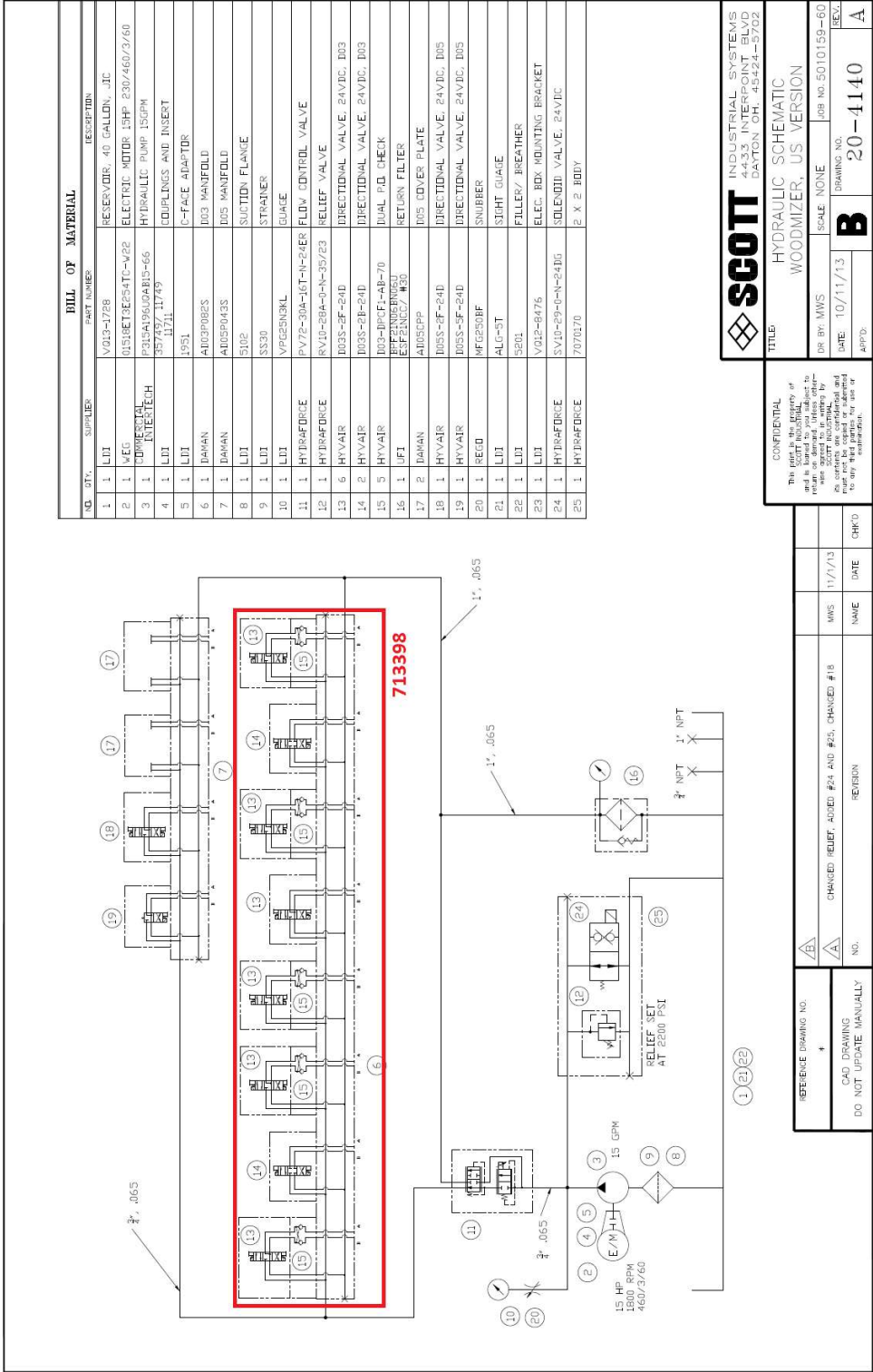

BILL OF MATERIAL

QTY.	SUPPLIER	PART NUMBER	DESCRIPTION
1	LID	VQ13-4788	RESERVOIR, 40 GALLON, JIC
2	WEG	D518BET2654T-V22	ELECTRIC MOTOR 15HP, 230/460/3/60
3	COMPRESSOR	PC10A9000AR10-66	HYDRAULIC PUMP 15GPM
4	LID	35111V49	COUPLINGS AND INSERT
5	LID	1171	C-FACE ADAPTOR
6	DAMAN	A103P085	D03 MANIFOLD
7	DAMAN	A005P0433	D05 MANIFOLD
8	LID	3102	SUCTION FLANGE
9	LID	SS30	STAINER
10	LID	VP16BNK1	GUAGE
11	HYDRAFORCE	PV72-30A-16T-N-24R	FLOW CONTROL VALVE
12	HYDRAFORCE	RV10-28A-0-N-35/23	RELIEF VALVE
13	HYVAIR	1033-SF-24D	DIRECTIONAL VALVE, 24VDC, D03
14	HYVAIR	1033-ZB-24D	DIRECTIONAL VALVE, 24VDC, D03
15	HYVAIR	1033-PCF-AB-70	DUAL P.D. CHECK
16	UF1	BF21NDR06UJ	RETURN FILTER
17	DAMAN	A105CPP	D05 COVER PLATE
18	HYVAIR	1033-SF-24D	DIRECTIONAL VALVE, 24VDC, D05
19	HYVAIR	1033-SF-24D	DIRECTIONAL VALVE, 24VDC, D05
20	RECQ	MFG250BF	SNIBBER
21	LID	ALQ-5T	SIGHT GUAGE
22	LID	5201	FILLER/ BREATHER
23	LID	VQ12-8476	ELEC. BOX MOUNTING BRACKET
24	HYDRAFORCE	SV10-29-C-N-24D1C	SOLENOID VALVE, 24VDC
25	HYDRAFORCE	707070	2 X 2 BODY

SCOTT INDUSTRIAL SYSTEMS
4433 INTERPOINT BLVD
DAYTON OH, 45424-5702

HYDRAULIC SCHEMATIC
WOODMIZER, US VERSION

DR BY: MWS
DATE: 10/11/13
SCALE: NONE
DWM NO: 5010159-60
REV: A

APPD: 20-4140

CONFIDENTIAL
This SCOTT Industrial System drawing is the property of SCOTT Industrial Systems and is to be used only for the specific application for which it was prepared. It is not to be used for any other purpose, in whole or in part, without the written consent of SCOTT Industrial Systems.

NO.	REVISION	NAME	DATE	CHKD
1	CHANGED RELIEF, ADDED #24 AND #25, CHANGED #18	MWS	11/1/13	

REFERENCE DRAWING NO: 4
CAD DRAWING
DO NOT UPDATE MANUALLY

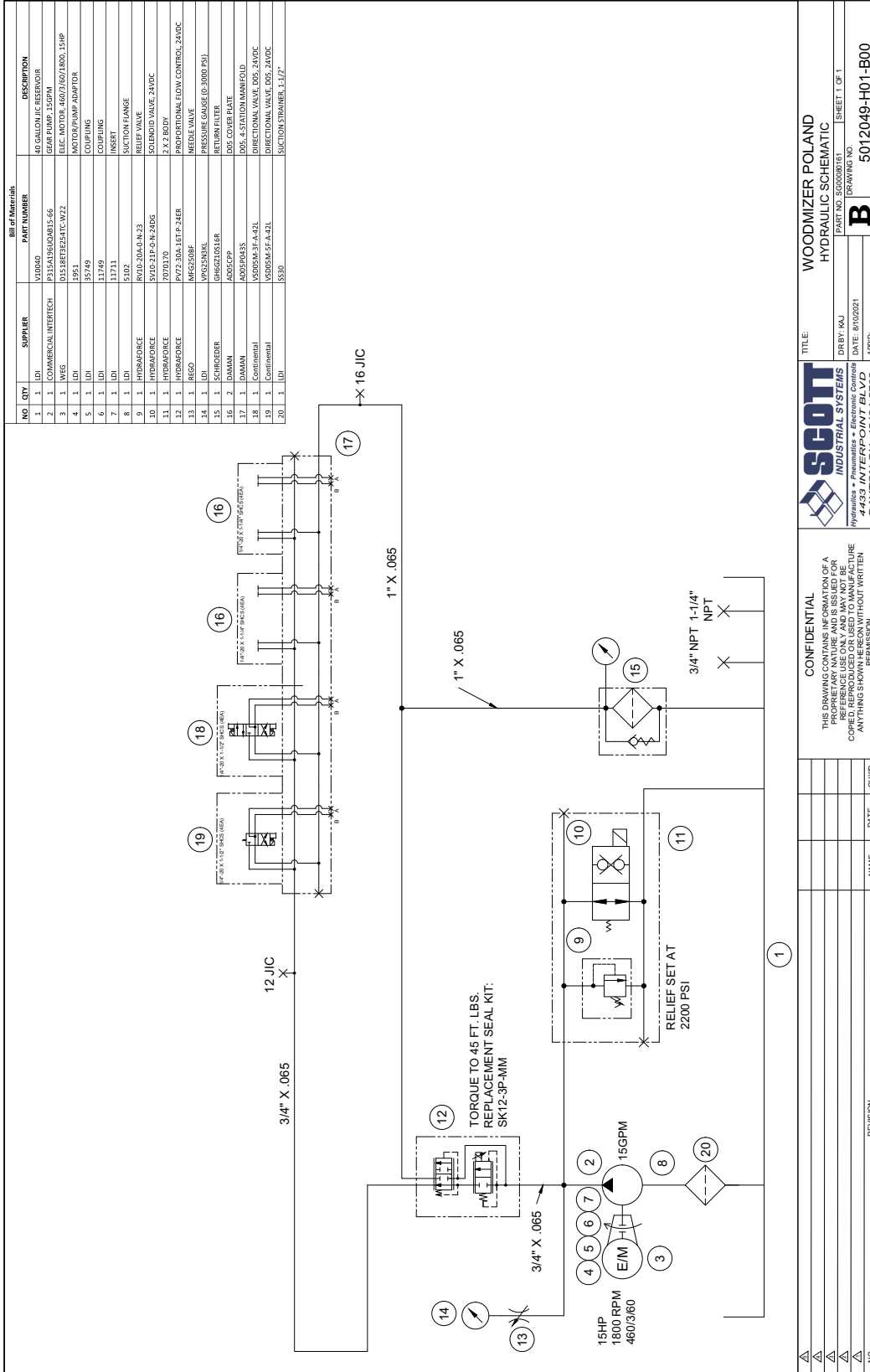

NO.	QTY.	SUPPLIER	PART NUMBER	DESCRIPTION
1	1	LDI	VTD04D	40 GALLON J.C. RESERVOIR
2	1	COMMERCIAL INTERTECH	P315A195000B15-66	GEAR PUMP, 150GPM
3	1	WEG	01518E1E254TC.W22	ELEC. MOTOR, 460/3/1800/1800, 15HP
4	1	LDI	1951	MOTOR/PUMP ADAPTOR
5	1	LDI	35749	COUPLING
6	1	LDI	11749	COUPLING
7	1	LDI	11711	WASER
8	1	LDI	5102	FLOW RANGE
9	1	HYDRASPACE	PS2313P-24VDC	SOLENOID VALVE, 24VDC
10	1	HYDRASPACE	PS2313P-24VDC	SOLENOID VALVE, 24VDC
11	1	HYDRASPACE	PS2313P-24VDC	SOLENOID VALVE, 24VDC
12	1	HYDRASPACE	PS2313P-24VDC	SOLENOID VALVE, 24VDC
13	1	HYDRASPACE	PS2313P-24VDC	SOLENOID VALVE, 24VDC
14	1	HYDRASPACE	PS2313P-24VDC	SOLENOID VALVE, 24VDC
15	1	HYDRASPACE	PS2313P-24VDC	SOLENOID VALVE, 24VDC
16	1	HYDRASPACE	PS2313P-24VDC	SOLENOID VALVE, 24VDC
17	1	HYDRASPACE	PS2313P-24VDC	SOLENOID VALVE, 24VDC
18	1	HYDRASPACE	PS2313P-24VDC	SOLENOID VALVE, 24VDC
19	1	HYDRASPACE	PS2313P-24VDC	SOLENOID VALVE, 24VDC
20	1	LDI	5530	SUCTION STRAINER, 1.1/2"

SCOTT INDUSTRIAL SYSTEMS
 Hydraulics • Pneumatics • Electronic Controls
 4433 INTERPOINT BLVD
 DAYTON OH 45424-5702

TITLE: WOODMIZER POLAND HYDRAULIC SCHEMATIC
 PART NO. S50008161 SHEET 1 OF 1
 DREW: JAJ DATE: 8/10/2021 DRAWING NO. 5012049-H01-B00
 APPD: B

CONFIDENTIAL
 THIS DRAWING CONTAINS INFORMATION OF A PROPRIETARY NATURE AND IS ISSUED FOR COPIED, REPRODUCED OR USED TO MANUFACTURE ANYTHING SHOWN HEREON WITHOUT WRITTEN PERMISSION

NO.	REVISION	NAME	DATE	CHKD

SECTION 9 MOTOR BRAKE

9.1 Motor Brake Maintenance

Maintenance intervals

Service brakes	<ul style="list-style-type: none"> ■ after 4000 hours of operation at the latest or every six months
-----------------------	---

TABLE 9-1.



IMPORTANT! Brakes with defective armature plates, cheese head screws, springs or flanges must be replaced completely.

Please observe the following for inspections and maintenance operations:

- Remove impurities through oil and grease using brake cleaning agents, if necessary, replace brake after finding out the cause of the contamination. Dirt deposits in the air gap between stator and armature plate impair the function of the brake and must be removed.
- After replacing the rotor, the original braking torque will not be reached until the run-in operation of the friction surfaces has been completed. After replacing the rotor, run-in armature plates and flanges have an increased initial rate of wear.

Checking the rotor thickness



DANGER! The motor must not be running when checking the rotor thickness.

- Remove the motor cover and seal ring (if mounted).
- Measure the rotor thickness with a caliper gauge. On brakes with friction plates, observe edging on outer diameter of friction plate.
- Compare measured rotor thickness with minimally permissible rotor thickness. [See Table 9-2.](#)
- Replace the complete rotor if necessary.

Check the air gap

- Measure the air gap "s_{Lü}" between armature plate and rotor using a feeler gauge (see chapter 3.3).
- Compare the measured air gap to the maximum permissible air gap "s_{Lümax}." (see table below).

- If necessary, adjust the air gap to "sLürated".

Brake type	sLürated +0.1mm -0.05mm	sLümax Service brake	Max. adjustment permissible wear	Rotor thickness		Excess of the adjuster nut h _E max. [mm]
				min. ¹⁾ [mm]	max. [mm]	
INTORQ BFK458-25	0,4 mm (1/64")	1,0 mm (3/64")	4,0 mm (5/32")	12 mm (15/32")	16 mm (5/8")	17 mm (43/64")

TABLE 9-2.

EC declaration of conformity according to EC Machinery Directive 2006/42/EC Annex II, 1.A

Manufacturer:

Wood-Mizer Industries sp. z o.o.
Nagórna 114, 62-600 Koło; Poland
Tel. +48 63 26 26 000

This declaration of conformity is issued under the sole responsibility of the manufacturer.

Following machine in our delivered version complies with the appropriate essential safety and health requirements of the EC Machinery Directive 2006/42/EC based on its design and type, as brought into circulation by us. In case of alteration of the machine, not agreed by us, this declaration is no longer valid.

We, the undersigned herewith declare, that:

Designation of the machine: **Log Horizontal Bandsaw**

TYPE:

No. of manufacturer:

**Is in conformity with the following
EC directives:**

EC Machinery Directive 2006/42/EC
EC Electromagnetic Compatibility Directive
2014/30/EU

**And is in conformity with the following
Harmonized Standards:**

PN-EN 1807-2:2013-08

Notified Body according to annex IV:

Sieć Badawcza Łukasiewicz
Krakowski Instytut Technologiczny
Zakopiańska 73
30-418 Kraków

Notification No:

1455

EC type-examination certificate no.:

1455-MD-010/22

Responsible for Technical Documentation:

Piotr Adamiec / Engineering Manager
Wood-Mizer Industries Sp. z o.o.
62-600 Koło, Nagórna 114, Poland
Tel. +48 63 26 26 000

Place/Date/Authorized Signature:

Koło, 31.01.2022



Title :

Engineering Manager