

D40 Engine

Safety, Operation, Maintenance & Parts Manual

| | |
|---------------------|-------------------|
| LT30 Super | rev. E6.06 |
| LT40 Super | rev. E6.06 |
| LT30HD Super | rev. E7.06 |
| LT40HD Super | rev. E7.06 |



Safety is our #1 concern! Read and understand all safety information and instructions before operating, setting up or maintaining this machine.

Form #659

Table of Contents

Section-Page

| | | |
|------------------|--|------------|
| SECTION 1 | SAFETY & GENERAL INFORMATION | 1-1 |
| 1.1 | Refueling | 1-1 |
| 1.2 | Engine Operation..... | 1-2 |
| 1.3 | Battery Handling | 1-4 |
| 1.4 | General Information | 1-5 |
| SECTION 2 | OPERATION | 2-1 |
| 2.1 | Starting The Engine..... | 2-1 |
| 2.2 | Cold Weather Operation..... | 2-3 |
| SECTION 3 | MAINTENANCE | 3-1 |
| 3.1 | Engine Oil Filter | 3-2 |
| 3.2 | Air Cleaner | 3-3 |
| 3.3 | Cooling System | 3-4 |
| 3.4 | Fuel Filter (Inline) | 3-5 |
| 3.5 | Primary Fuel Filter | 3-5 |
| 3.6 | Battery | 3-6 |
| 3.7 | Alternator Belt..... | 3-7 |
| 3.8 | Miscellaneous Maintenance | 3-8 |
| 3.9 | RPM Adjustments | 3-9 |
| 3.10 | Storage..... | 3-11 |
| SECTION 4 | REPLACEMENT PARTS | 4-1 |
| 4.1 | How To Use The Parts List | 4-1 |
| 4.2 | Sample Assembly | 4-1 |
| 4.3 | Fuel Tank..... | 4-2 |
| 4.4 | Engine Mount Assembly | 4-3 |
| 4.5 | Engine Assembly..... | 4-4 |
| 4.6 | Primary Fuel Filter | 4-6 |
| 4.7 | Alternator Assembly..... | 4-7 |
| 4.8 | Relay/Throttle Assembly..... | 4-9 |
| 4.9 | Muffler Assembly..... | 4-11 |
| 4.10 | Drive Assembly..... | 4-12 |
| 4.11 | Radiator Assembly | 4-13 |
| 4.12 | Engine/Muffler Guards..... | 4-14 |
| 4.13 | Engine Pulley Guards..... | 4-15 |
| 4.14 | Air Cleaner Assembly | 4-16 |
| SECTION 5 | ELECTRICAL INFORMATION | 5-1 |
| 5.1 | Electrical Symbol Diagram, Super D40 | 5-1 |
| 5.2 | Electrical Components, Super D40 | 5-4 |
| 5.3 | Battery Specifications, Super D40 | 5-6 |

Table of Contents

Section-Page

| | | |
|-----|-------------------------------------|-----|
| 5.4 | Electrical Wiring Diagram, D40..... | 6-1 |
|-----|-------------------------------------|-----|

SECTION 1 SAFETY & GENERAL INFORMATION



IMPORTANT! This manual is provided as a supplement to the equipment manufacturer's manuals. This manual takes into account the specific use of engines on the Wood-Mizer sawmill. Only safety, maintenance, and operating procedures that are not provided by the manufacturer are supplied in this manual. Refer to the manufacturer's manual before attempting to operate this equipment.



This symbol calls your attention to instructions concerning your personal safety. Be sure to observe and follow these instructions. This symbol accompanies a signal word. The word **DANGER** indicates an imminently hazardous situation which, if not avoided, will result in death or serious injury. **WARNING** suggests a potentially hazardous situation which, if not avoided, could result in death or serious injury. **CAUTION** refers to potentially hazardous situations which, if not avoided, may result in minor or moderate injury to persons or equipment. Read all safety instructions before operating this equipment and observe all safety warnings!

1.1 Refueling



DANGER! Due to the flammable nature of fuel and oil, never smoke, weld, grind or allow sparks near your engine or storage tanks, especially during times of fueling.

DANGER! Never allow fuel to spill on a hot engine during fueling operations or otherwise. The hot temperature of your engine could induce a fire or explosion.



WARNING! Store gasoline away from sawdust and other flammable materials. Failure to do so may result in serious injury.

1.2 Engine Operation



DANGER! Operate your engine/machine only in well ventilated areas. The exhaust gases of your engine can cause nausea, delirium and potentially death unless adequate ventilation is present.

DANGER! Never operate an engine with a fuel or oil leak. The leaking fuel or oil could potentially come in contact with hot surfaces and ignite into flames.

DANGER! Engine components can become very hot during operation. Avoid contact with any part of a hot engine. The exhaust components of your engine are especially hot during and following operation. Contact with hot engine components can cause serious burns. Therefore, never touch or perform service functions on a hot engine. Allow the engine to cool sufficiently before beginning any service function.

DANGER! Always be aware of and take proper protective measures against rotating shafts, pulleys, fans, etc. Always stay a safe distance from rotating members and make sure that loose clothing or long hair does not engage rotating members resulting in possible injury.

DANGER! Always be sure the blade is disengaged and all persons are out of the path of the blade before starting the engine or motor. Failure to do so will result in serious injury.



WARNING! Do not for any reason adjust the engine drive belts or belt support bracket with the engine running. Doing so may result in serious injury.

WARNING! Do not operate engine without proper and operational spark arrester/muffler. Sparks emitted from the engine exhaust could ignite surrounding materials, causing serious injury or death.

WARNING! Remove the blade before performing any engine service. Failure to do so may result in serious injury.



WARNING! Always disconnect the machine battery cables before performing service functions. Diesel engines by default require diesel fuel and lubricating oil for operation. Both diesel fuel and lubricating oil are flammable. Disconnection of the battery cables will reduce the possibility of sparks with potentially resultant fires or explosions.

WARNING! Be sure the power feed switch is in the neutral position before turning the key switch to the on (#1) or accessory (#3) position. This prevents accidental carriage movement, which may cause serious injury or death.

WARNING! Always wear proper and necessary safety equipment when performing service functions. Proper safety equipment includes eye protection, breathing protection, hand protection and foot protection.



IMPORTANT! Always dispose of coolant, oil, fuel, oil filters and fuel filters in a responsible manner and in compliance with local, state and federal regulations.



CAUTION! Do not crank starter for more than 7 seconds at one time during starting attempts. Damage to the engine may result.

CAUTION! Let engine idle for 2 minutes before applying load to prevent engine damage.

CAUTION! Let engine idle for 2 minutes before shutting off to prevent engine damage. A minimum 2 minute idle time is also recommended to allow the battery charge to recover before the engine is shut off.

CAUTION! During the initial 50 hours, do not exceed 70% of the maximum rated power. Damage to the engine may result.

CAUTION! Do not adjust the high-end RPM above 3200. Doing so may cause damage to the engine.

1.3 Battery Handling



DANGER! Batteries expel explosive gases. Keep sparks, flames, burning cigarettes, or other ignition sources away at all times. Always wear safety goggles and a face shield when working near batteries. Failure to do so will cause serious injury.¹



WARNING! Charge the battery in a well ventilated area. Do not attempt to charge a frozen battery.

WARNING! Use extreme care to avoid spilling or splashing electrolyte (which is dilute sulfuric acid) as it can destroy clothing and burn the skin. If electrolyte is spilled or splashed on clothing or the body, it should be neutralized immediately and then rinsed with clean water. A solution of baking soda, or household ammonia, and water may be used as a neutralizer.

Electrolyte splashed into the eyes is extremely dangerous. If this should happen, force the eye open and flood it with cool, clean water for approximately fifteen minutes. A doctor should be called immediately when the accident occurs and “on-the-spot” medical attention given if possible. If a doctor cannot come to the scene of the accident immediately, follow his instructions concerning actions to take. Do not add eye drops or other medication unless advised to do so by the doctor. Do not place a battery or acid within the reach of children. If acid (electrolyte) is taken internally drink large quantities of water or milk. Follow with milk of magnesia, beaten egg or vegetable oil. Call a physician immediately.

If electrolyte is spilled or splashed on any surface of the machine, it should be neutralized and rinsed with clean water.¹

1. Battery Council International, copyright 1987

1.4 General Information



IMPORTANT! Read the engine manual for instructions and safety precautions before operating the engine.

For use with the Wood-Mizer sawmill, the radiator, air cleaner, alternator, and starter used differ from Lombardini's standard components.

See **Figure 1-1**. The main components of the diesel engine are shown.

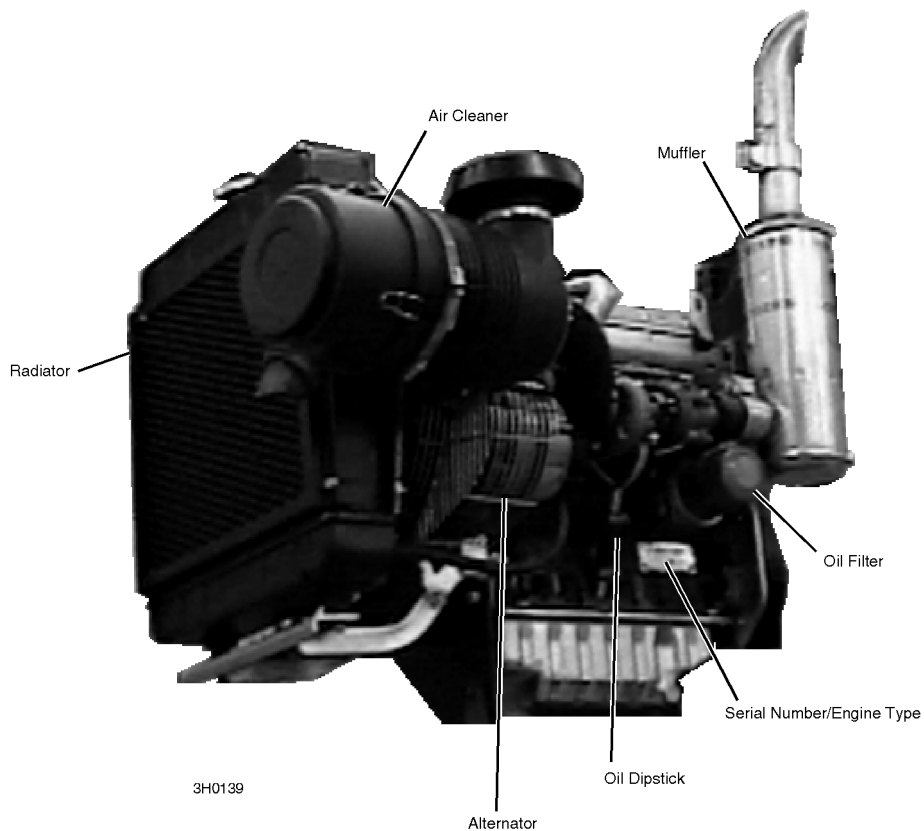

FIG. 1-1

1 Safety & General Information









General Information

SECTION 2 OPERATION

2.1 Starting The Engine

Engine Control Lights

See **Figure 2-1**. The following indicator lights are located on the sawmill control panel. See the manufacturer's engine manual for troubleshooting tips.

-  **Alternator Charge Indicator:** Lights up if the alternator is not charging the battery.
 **NOTE:** Indicator also lights up when engine is started and remains lit until engine initially reaches approximately 1300RPM.
-  **Engine Temperature Indicator:** Lights up if the engine is overheating. **LT30 Super Rev. C2.01, LT40 Super Rev. C2.01, and LT30HD/40HD Super Rev. C2.01 and later only:** A circuit breaker assembly in the engine harness will shut the engine off if the engine overheats. Turn the key switch off and allow the engine to cool for a period of time before restarting. If the overheating condition persists, stop operating the engine until the condition is corrected.
-  **Key Switch Indicator:** Lights up when the key is in either the on or accessory (#1 or #3) position.

-  **Oil Indicator:** Lights up if the oil pressure is too low.

-  **Glow Plug Indicator:** Lights up after the key has been turned to the on (#1) position.

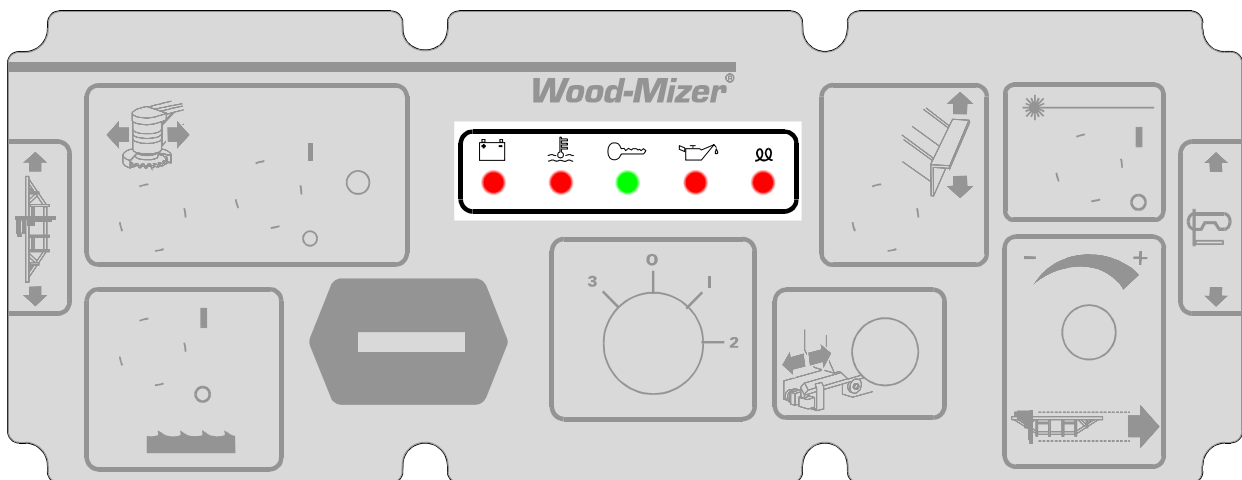

FIG. 2-1

2 Operation

Starting The Engine

See **Table 2-1. IMPORTANT!** The glow plug sensing relay is disconnected on LT30 Super Rev. B1.00, LT40 Super Rev. B1.00, LT30HD Super and LT40HD Super Rev. B1.00 to provide manual control of glow plug operation. Previous revisions can be modified to improve hot starting performance ([see form #250](#)). See the table for recommended glow plug on times.

| On Times For Manually Operated Glow Plugs | |
|---|-----------------------------|
| Ambient Temperature | Suggested Glow Plug On Time |
| Less Than 32° F (0° C) | 30 Seconds |
| 32 - 60° F (0 - 15° C) | 25 Seconds |
| 60 - 80° F (15 - 27° C) | 15 Seconds |
| Above 80° F (27° C) | 10 Seconds |

TABLE 2-1

NOTE: The glow plug light will stay on indefinitely when the key is in the pre-start (1) position. The glow plug light will go out after the engine is started.



CAUTION! Avoid leaving the key in the pre-start (1) position for more than 30 seconds while the engine is not running. Doing so will drain the sawmill battery which may reduce its service life.

Engine Start



DANGER! Always be sure the blade is disengaged and all persons are out of the path of the blade before starting the engine or motor. Failure to do so will result in serious injury.



WARNING! Be sure the power feed switch is in the neutral position before turning the key switch to the on (#1) or accessory (#3) position. This prevents accidental carriage movement, which may cause serious injury or death.



CAUTION! Do not crank starter for more than 7 seconds at one time during starting attempts. Damage to the engine may result.

CAUTION! Let engine idle for 2 minutes before applying load to prevent engine damage.

1. See engine manual lubricating oil for specific temperature-range oil recommendations.
2. Use #2 or better quality diesel fuel for above freezing starting. Use a #1 quality diesel fuel for below freezing starting.

3. Turn the key switch on the control panel to the on (#1) position.
4. Wait the recommended glow plug on time ([See Table 2-1.](#))
5. Turn the key switch to the start (#2) position and release.

Engine Shutoff



CAUTION! Let engine idle for 2 minutes before shutting off to prevent engine damage. A minimum 2 minute idle time is also recommended to allow the battery charge to recover before the engine is shut off.

Turn the key switch to the off (#0) position.

2.2 Cold Weather Operation

When sawing in extremely cold weather, you may need to use a different engine oil. Lombardini recommends using 0W30 for operating temperatures between -13° F (-25 C) and -31° F (-35° C). When sawing in temperatures below -31° F (-35° C), Lombardini recommends using a synthetic-based oil such as Mobil Delvac 1 5W40.

Wood-Mizer also offers an accessory engine water heater for Lombardini diesel engines. The heater unit installs around the lower radiator hose. When plugged into a grounded 120V outlet, the heater will keep the engine coolant warm enough to allow easy starts in cold climates.

SECTION 3 MAINTENANCE



IMPORTANT! This manual only provides information about additional procedures or procedures to be performed at different time intervals than found in the engine manufacturer's manuals. Refer to the [manufacturer's manual](#) for complete maintenance instructions.

DANGER! Engine components can become very hot during operation. Avoid contact with any part of a hot engine. The exhaust components of your engine are especially hot during and following operation. Contact with hot engine components can cause serious burns. Therefore, never touch or perform service functions on a hot engine. Allow the engine to cool sufficiently before beginning any service function.



WARNING! Remove the blade before performing any engine service. Failure to do so may result in serious injury.

WARNING! Always disconnect the machine battery cables before performing service functions. Diesel engines by default require diesel fuel and lubricating oil for operation. Both diesel fuel and lubricating oil are flammable. Disconnection of the battery cables will reduce the possibility of sparks with potentially resultant fires or explosions.

WARNING! Always wear proper and necessary safety equipment when performing service functions. Proper safety equipment includes eye protection, breathing protection, hand protection and foot protection.



This symbol identifies the interval (hours of operation) at which each maintenance procedure should be performed. "AR" signifies maintenance procedures which should be performed as required

3.1 Engine Oil Filter

See Figure 3-1. The following chart details lubricating oil viscosity as a function of ambient temperature. Select the lubricating oil viscosity based upon the prevailing temperature range expected. If your application will be subject to large ambient temperature ranges during a given oil change interval, select the lubricating oil viscosity based upon the highest temperature expected. Should the prevailing ambient temperatures change during a given oil service period interval, and the lubricating oil within the engine is reflective of a lower temperature range, the lubricating oil should be changed to reflect the prevailing temperature.

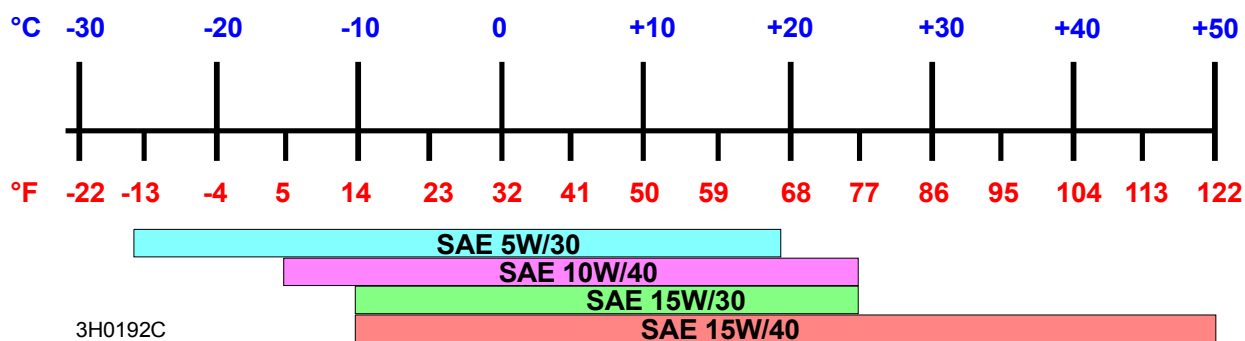

3H0192C

FIG. 3-1

NOTE: The use of straight weight lubricating oils such as SAE 40, SAE 30, etc. is not recommended for Lombardini diesel engines.

Lombardini recommends that only API (American Petroleum Institute) grades 'CD' or higher be used within Lombardini diesel engines. In addition to the API rating, lubricating oils should also meet or exceed MIL-L-2104D. Without respect to brand name, lubricating oil meeting API grade 'CD' and sourced from a reputable supplier are acceptable for use within Lombardini diesel engines.

The use of "SEMI-SYNTHETIC" lubricating oils meeting the grade and viscosity guidelines presented above is acceptable and may reduce engine wear rates due to the superior characteristics of the "SEMI-SYNTHETIC" oil with respect to mineral based engine lubricating oils.

Lombardini does not recommend the use of ANY oil additive other than those included within the respective manufacturer oil blends. Under no circumstances should oil additives claiming "teflon", "molecular adhesion", low wear rates etc. be added. These aftermarket oil additives may actually break down the recommended lubricating oil chemical properties resulting in accelerated engine wear.

When operating in temperatures below those specified in the chart, [See Section 2.2](#).

Oil capacity (including oil filter) is 4.5 quarts, or 4.3 liters.

8

Check the oil level every 8 hours of operation. Add oil as necessary.

125

Change the oil and replace the oil filter after the first 50 hours of operation. Change the oil every 125 hours and replace the oil filter every 250 hours thereafter.



IMPORTANT NOTE! Before reinstalling the clean oil filter, wipe all dirt and oil deposits from the oil filter receptacle.

3.2 Air Cleaner

8

Empty the air debris collector every 8 hours of operation.

See Figure 3-2. Squeeze the rubber tip of the collector to open it. After all debris has been emptied from the collector, release the tip and allow it to close.



WARNING! Always wear proper and necessary safety equipment when performing service functions. Proper safety equipment includes eye protection, breathing protection, hand protection and foot protection.

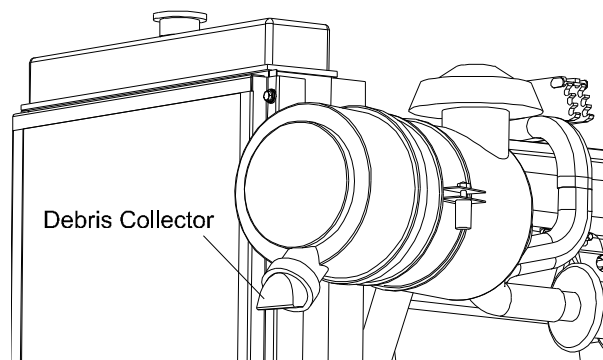

FIG. 3-2

AR

Replace the air filter when air filter indicator shows need (or every year). The air cleaner used on the Lombardini Diesel for Wood-Mizer sawmill applications is a special, non-standard filter which becomes more efficient with use. There is no need for periodic cleaning or servicing.

See Figure 3-3. The indicator is located on the side of the air cleaner housing, behind the radiator. A red band will appear in the sight window when the air restriction is at its maximum limit. Change the air filter and push the reset button on the indicator.

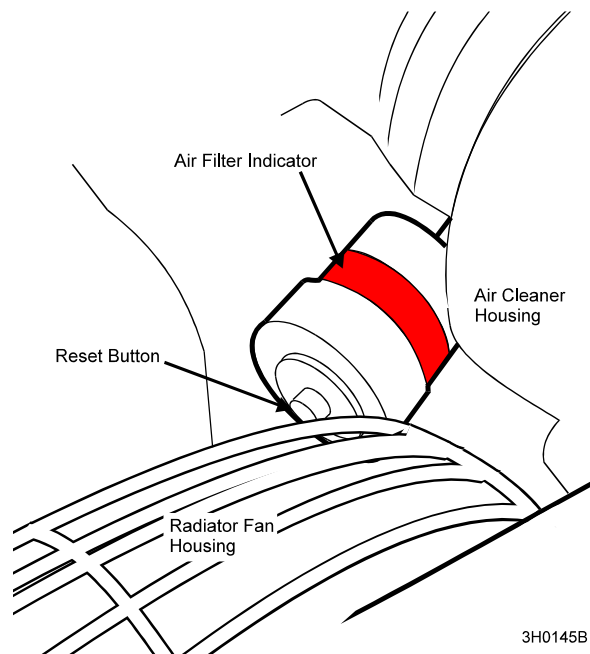

FIG. 3-3

3.3 Cooling System

8

Check the coolant level every 8 hours of operation.

8

Check the radiator fins every 8 hours of operation.

250

Clean the radiator fins every 250 hours of operation.

1000

Replace the coolant every 1000 hours of operation or every 2 years, whichever comes first. Use a mixture of 50% antifreeze and 50% water.

3.4 Fuel Filter (Inline)

LT30 Super Rev. C1.00 - C1.02
LT40 Super Rev. C1.00 - C1.02
LT30HD Super Rev. C1.00 - C1.02
LT40HD Super Rev. C1.00 - C1.02

250 Replace the in-line fuel filter every 250 hours of operation. It is recommended that the inline fuel filter be replaced with the primary cartridge filter/water separator system ([See Section 3.5](#)). This system will eliminate water and particles that can cause premature failure of injection system components.

3.5 Primary Fuel Filter

LT30 Super Rev. C2.00+
LT40 Super Rev. C2.00+
LT30HD Super Rev. C2.00+
LT40HD Super Rev. C2.00+

1500 **See Figure 3-4.** Replace the primary fuel filter cartridge every 1500 hours or one year of operation. After replacing the filter cartridge, loosen the air bleed screw and operate the fuel pump bail until fuel begins to flow from the valve and is free of air bubbles. Tighten the bleed screw. Inspect the water separator bowl periodically and drain the bowl as required by turning the drain cap counterclockwise as viewed from the bottom.

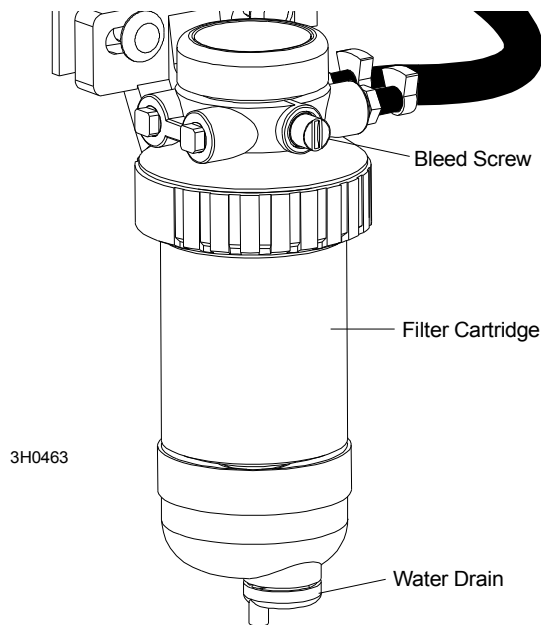

FIG. 3-4

3.6 Battery



Check the battery electrolyte level every 50 hours of operation. See manufacturer's manual for instructions.



DANGER! Batteries expel explosive gases. Keep sparks, flames, burning cigarettes, or other ignition sources away at all times. Always wear safety goggles and a face shield when working near batteries. Failure to do so will cause serious injury.¹

1. Battery Council International, copyright 1987

3.7 Alternator Belt

500

Check the alternator belt tension every 500 hours. Also check the alternator belt for tension and wear when battery is not charging properly or when the alternator belt is squealing. Adjust as needed.

1. Remove the alternator belt guard.
2. Loosen the two bolts in the slotted alternator bracket holes (opposite holes in front and rear of bracket).

See Figure 3-5.

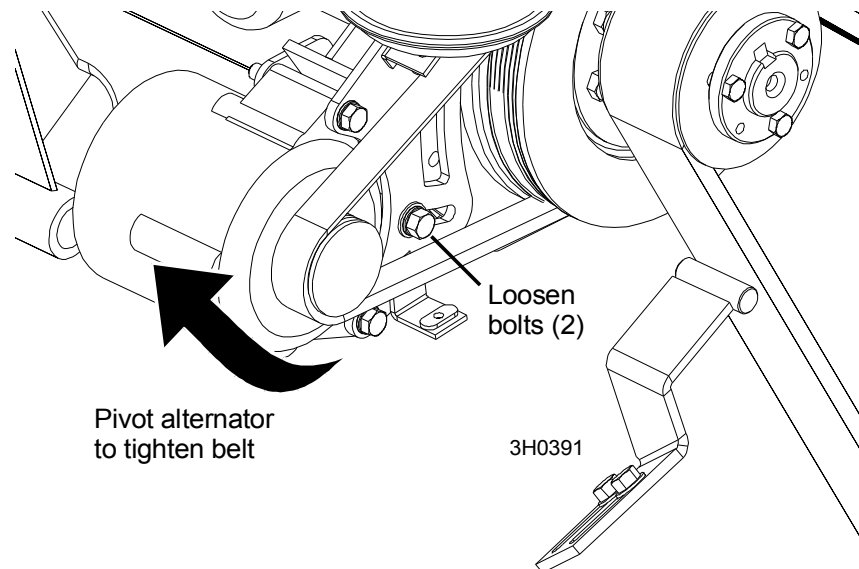

FIG. 3-5

3. Pivot the alternator to tighten the belt. Retighten the adjustment bolts and replace the belt guard.

1000

Replace the alternator belt every 1000 hours.

3.8 Miscellaneous Maintenance

500

Check the valve clearance every 500 hours of operation. Adjust if necessary. See engine manual for further details.

1000

Clean the fuel tank every 1000 hours of operation.

1000

Clean and set the injectors every 1000 hours of operation. See engine manual for more information.

2500

Replace the timing belt every 2500 hours of operation.

2500

Perform a partial overhaul inspection as detailed in the engine manual every 2500 hours of operation.

5000

Perform a complete overhaul inspection as detailed in the engine manual every 5000 hours of operation.

3.9 RPM Adjustments



WARNING! Remove the blade before performing any engine service. Failure to do so may result in serious injury.

200

Check the RPM with a tachometer after the first 20 hours of operation and every 200 hours thereafter.

Before checking the RPM, make sure belt and brake strap tension are correct (See Saw-mill Maintenance). Also check oil, fuel, and coolant levels.

1. Start the engine to measure the low-end RPM. Let idle for 10 minutes.
2. With the engine at idle, check the low-end RPM. Adjust to 1500. To decrease speed, loosen the idle adjustment bolt. To increase speed, tighten the idle adjustment bolt. Tighten the lock nut to hold the bolt in place.

Make sure that the throttle linkage is not affecting the engine RPM while the clutch/brake handle is disengaged. Make sure the cable is not bent or kinked.

See Figure 3-6.

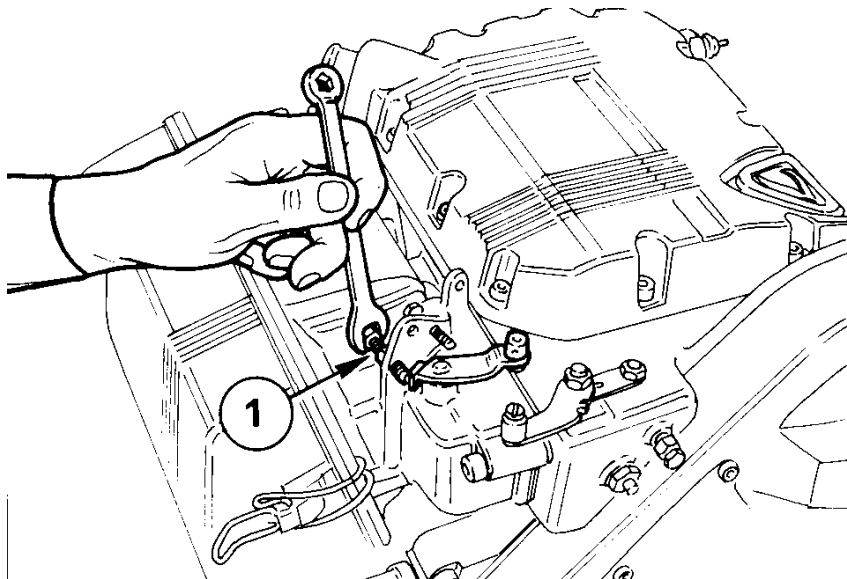

FIG. 3-6

3. Adjust the high-end RPM to 3200. To decrease speed, tighten the full speed adjustment bolt. To increase speed, loosen the full speed adjustment bolt. Tighten the lock nut to hold the bolt in place.

See Figure 3-7.



CAUTION! Do not adjust the high-end RPM above 3200. Doing so may cause damage to the engine.

The throttle cable should be tensioned just enough so that the engine revs as soon as the clutch/brake handle is engaged. **NOTE:** A properly adjusted throttle will extend the cable spring $1/4''$ to $3/8''$ (6.4 - 9.5 mm) when running and have a slight amount of slack in the cable when idling.

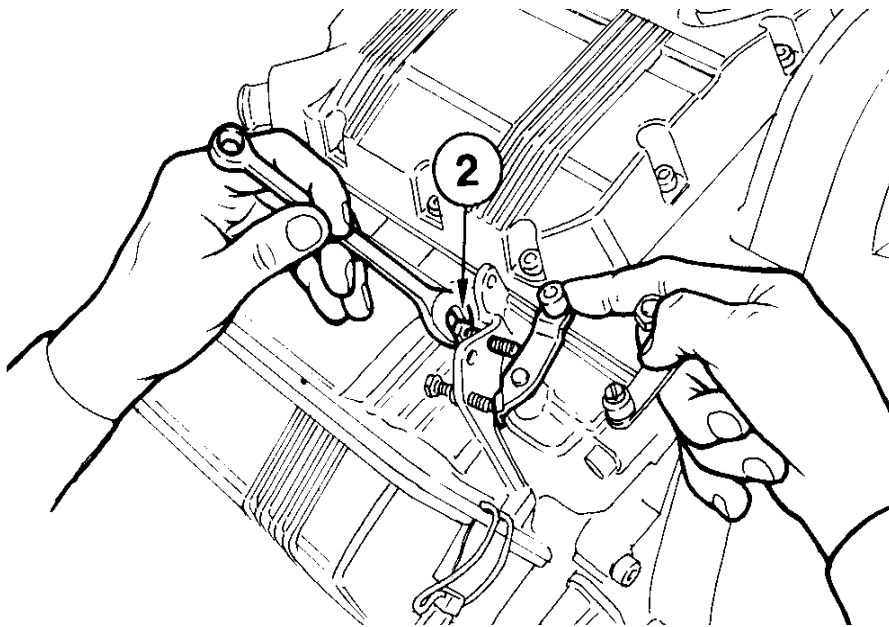

FIG. 3-7

3.10 Storage

Short Term Storage

If storing the engine over 30 days but under 6 months, take the following maintenance steps:

1. Idle the engine for 15 minutes before shutting off.
2. Drain oil and refill crankcase with protection oil MIL-1-644-P9. Run engine at 3/4 full speed for 5-10 minutes.
3. Shut off engine.
4. While the engine is still warm, drain oil. Refill crankcase with standard oil.
5. Remove the fuel filter and drain the fuel tank. Replace gasket if need and reinstall the fuel filter.
6. Carefully clean the radiator fins, heads and fan.
7. Seal all openings with tape.
8. Remove injectors. Poor a spoonful of SAE 30 oil into the cylinders. Manually rotate the cylinders to distribute the oil. Reinstall injectors.
9. Spray SAE 10W oil into exhaust and intake manifolds, rocker arm, valves, tappet, etc. Grease all unpainted parts.
10. Loosen the fan belt.
11. Wrap the engine in a plastic film.
12. Store the engine in a dry place. Keep away from soil and high voltage electric lines.

Long Term Storage

If storing over 6 months follow these additional guidelines:

1. Use a rustproof type MIL-L-21260-P10 grade 2 SAE 30 oil, such as ESSO RUST BAN 623-AGIP, RUSTIA C - SAE 30 for the lubrication and the injection system as well as for moving parts. Let the engine run with rustproof oil and drain any excess.
2. Coat the external unpainted surfaces with an antirust type MIL-C-16173D grade 3 oil, such as ESSO RUST BAN 398-AGIP, RUSTIA 100/F.
3. Replace coolant every 2 years.

Using Engine After Storage

Before using the engine after short or long term storage, perform the following steps:

1. Clean the outside of the engine.
2. Remove protections and covers.
3. Remove antirust oil with an appropriate solvent or degreaser.
4. Remove the injectors, pour a spoonful of standard oil into the cylinders and rotate manually to distribute the oil. Remove the oil pan and drain the protective oil.
5. Check the injectors, valve clearance, belt tension, head tightening, oil filter and air cleaner for proper setting. If the engine has been stored over 6 months, check bearings for corrosion.

SECTION 4 REPLACEMENT PARTS

4.1 How To Use The Parts List

- Use the table of contents or the index to locate the assembly that contains the part you need.
- Go to the appropriate section and locate the part in the illustration.
- Use the number pointing to the part to locate the correct part number and description in the table.
- Parts shown indented under another part are included with that part.
- Parts marked with a diamond (◆) are only available in the assembly listed above the part.

See the sample table below. Sample Part #A01111 includes part F02222-2 and subassembly A03333. Subassembly A03333 includes part S04444-4 and subassembly K05555. The diamond (◆) indicates that S04444-4 is not available except in subassembly A03333. Subassembly K05555 includes parts M06666 and F07777-77. The diamond (◆) indicates M06666 is not available except in subassembly K05555.

| 4.2 Sample Assembly | | | | |
|----------------------------|--|-----------|------|---|
| REF | DESCRIPTION (◆ Indicates Parts Available In Assemblies Only) | PART # | QTY. | |
| | SAMPLE ASSEMBLY, COMPLETE (INCLUDES ALL INDENTED PARTS BELOW) | A01111 | 1 | |
| 1 | Sample Part | F02222-22 | 1 | |
| | Sample Subassembly (Includes All Indented Parts Below) | A03333 | 1 | |
| 2 | Sample Part (◆ Indicates Part Is Only Available With A03333) | S04444-4 | 1 | ◆ |
| | Sample Subassembly (Includes All Indented Parts Below) | K05555 | 1 | |
| 3 | Sample Part (◆ Indicates Part Is Only Available With K05555) | M06666 | 2 | ◆ |
| 4 | Sample Part | F07777-77 | 1 | |

To Order Parts:

- From the continental U.S., call **1-800-448-7881** to order parts. From Europe call our European Headquarters and Manufacturing Facility in Kolo, Poland at **+48-63-2610233** or **+48-3912-1319**. Have your customer number, vehicle identification number, and part numbers ready when you call.
- From other international locations, contact the Wood-Mizer distributor in your area for parts.

4 Replacement Parts

Fuel Tank

4.3 Fuel Tank

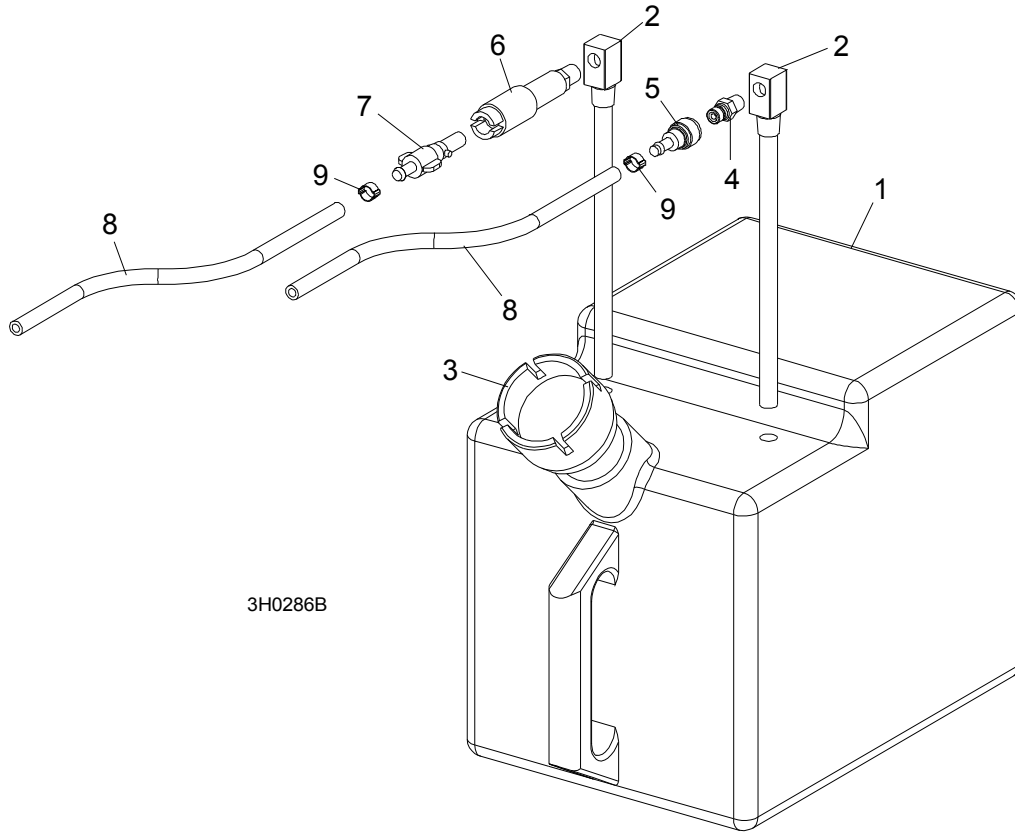

| REF | DESCRIPTION (◆ Indicates Parts Available In Assemblies Only) | PART # | QTY. |
|-----|--|----------|-------|
| 1 | Tank, 5 Gallon Diesel, Yellow | P12166 | 1 |
| 2 | Pickup, 9" Fuel | P12172 | 2 |
| 3 | Cap, 3/5 Gallon Fuel Tank | P09683 | 1 |
| 4 | Fitting, 1/4" NPT Male Quick Disconnect | 015583 | 1 |
| 5 | Fitting, Female Quick Disconnect Barb | 015582 | 1 |
| 6 | Fitting, 1/4" NPT Plastic Female Disconnect | P12175 | 1 |
| 7 | Fitting, 1/4" Barb Plastic Male Disconnect | P12176 | 1 |
| 8 | HOSE, 1/4" ID FUEL | P642 | 4.7 m |
| 9 | CLAMP, 7/32 - 1/2 HOSE | F81080-1 | 6 |

4.4 Engine Mount Assembly

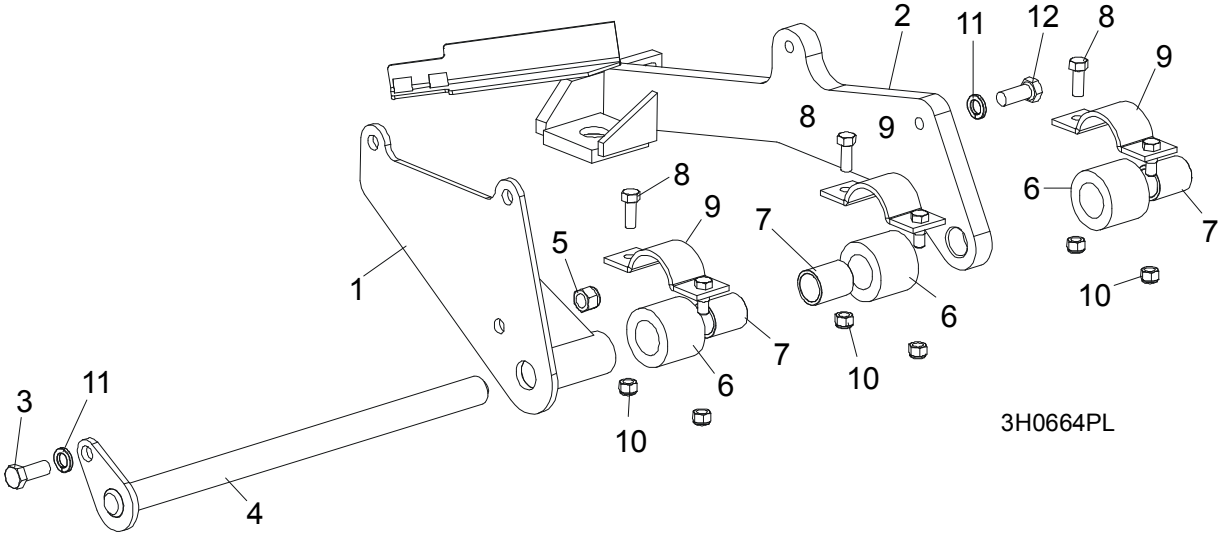

| REF | DESCRIPTION (◆ Indicates Parts Available In Assemblies Only) | PART # | QTY. | |
|-----|--|-----------|------|---|
| 1 | MOUNT, FRONT MOTOR | 014237 | 1 | |
| 2 | MOUNT WELDMENT, DIESEL MOTOR | 086802-1 | 1 | |
| 3 | BOLT, M12 X 30-8.8 HEX HEAD | F81004-22 | 1 | |
| 4 | PIN WELDMENT, MOTOR PIVOT | 014056 | 1 | |
| 5 | NUT, M12-8 HEX NYLON LOCK | F81034-2 | 1 | |
| 6 | BUSHING, RUBBER ASSEMBLY | A04127 | 3 | ◆ |
| 6 | Bushing, Motor Mount Rubber | 016378 | 1 | |
| 7 | Bushing, Clutch/Brake Lever | 016379 | 1 | |
| 8 | BOLT, M10 X 25-8.8 HEX HEAD | F81003-11 | 3 | |
| 9 | CLAMP WELDMENT, MOTOR MOUNT | 086200 | 3 | |
| 10 | NUT, M10-8 HEX NYLON LOCK | F81033-1 | 6 | |
| 11 | WASHER, 13 SPLIT LOCK | F81056-1 | 2 | |
| 12 | BOLT, M12 X 30-8.8 HEX HEAD | F81004-22 | 1 | |

4 Replacement Parts

Engine Assembly

4.5 Engine Assembly

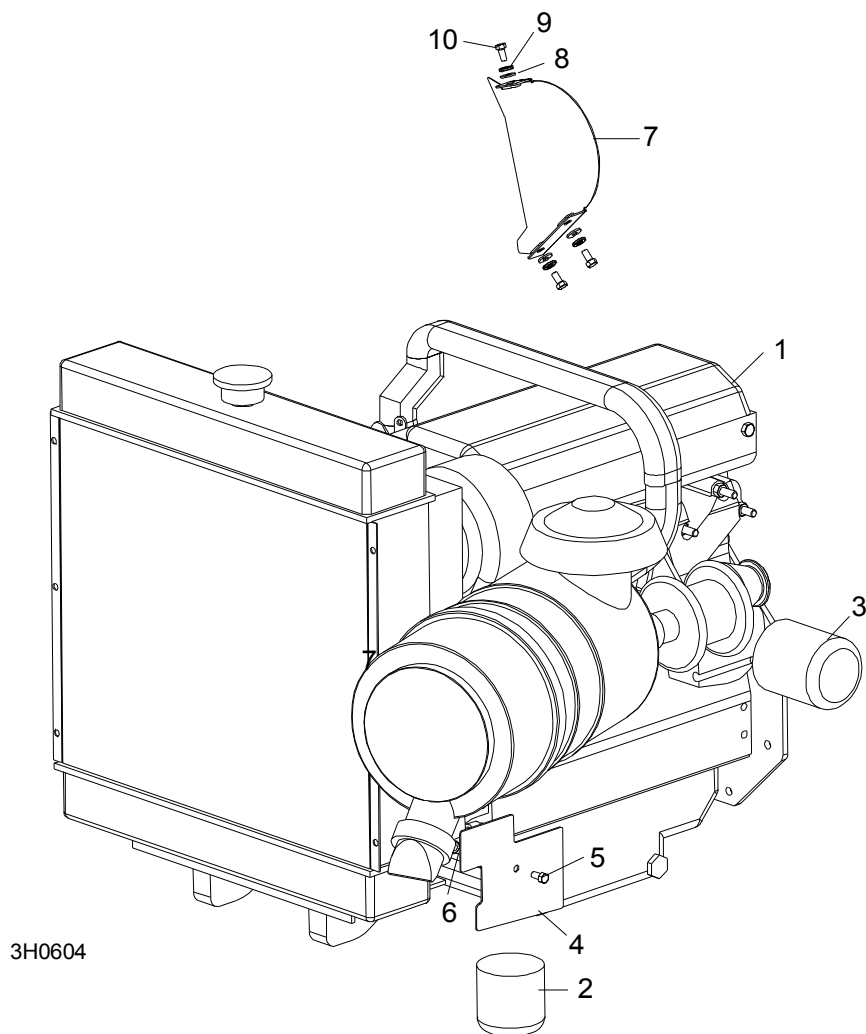

| REF | DESCRIPTION (◆ Indicates Parts Available In Assemblies Only) | PART # | QTY. | ◆ |
|-----|--|--------|------|---|
| 1 | ENGINE, 40HP LOMBARDINI DIESEL | 014092 | 1 | ◆ |
| | Cap, Oil Fill | 014294 | 1 | |
| 2 | Filter, Diesel Fuel | 014209 | 1 | |
| 3 | Filter, Diesel Oil | 014211 | 1 | |
| | Fuse Link, 80 Amp Glow Plug | 014350 | 1 | |
| | Gasket Kit, Lombardini Engine | 014293 | 1 | |
| | Plug, Diesel Glow | 014278 | 1 | |
| | Pump, Lombardini Fuel | 014289 | 1 | |
| | Pump, Lombardini Water | 014288 | 1 | |
| | Starter, Lombardini Diesel Engine | 014286 | 1 | |
| | Thermostat, Lombardini Engine | 014296 | 1 | |
| | Valve, Fuel | 014279 | 1 | |

| | | | | |
|-----------|---|-----------|---|--|
| | Guard, Lombardini Fan Left #6927-346 | 014747 | 1 | |
| | Guard, Lombardini Fan Right #6927-350 | 014748 | 1 | |
| | Rail Kit, Lombardini Replacement Fuel | 016073 | 1 | |
| 4 | PLATE, LOMBARDINI DUST SHIELD | 014400 | 1 | |
| 5 | BOLT, 1/4-20 X 1/2" HEX HEAD | F05005-15 | 1 | |
| 6 | NUT, 1/4-20 SELF-LOCKING | F05010-9 | 1 | |
| 7 | GUARD WELDMENT, D40 IDLER | 016065 | 1 | |
| 8 | WASHER, 7,4 FLAT | F81056-11 | 3 | |
| 9 | WASHER, Z 6,1 SPLIT LOCK | F81053-3 | 3 | |
| 10 | BOLT, 1/4-20 X 1/2" HEX HEAD | F05005-15 | 3 | |
| | HARNES ASSEMBLY, LOMBARDINI DIESEL ENGINE | 024452 | 1 | |
| | Breaker Assembly, Water Temp Max Circuit | 024453 | 1 | |
| | BELT, LOMBARDINI IDLER | 016071 | 1 | |
| | TOOL, LOMBARDINI 01460-049 TIMING BELT TENSIONER | 014085 | 1 | |
| | HEATER, OPTIONAL ENGINE WATER (NOT SHOWN) | 014635 | 1 | |
| | KIT, LOMBARDINI HEAD GASKET | 016178 | 1 | |

4 Replacement Parts

Primary Fuel Filter

4.6 Primary Fuel Filter

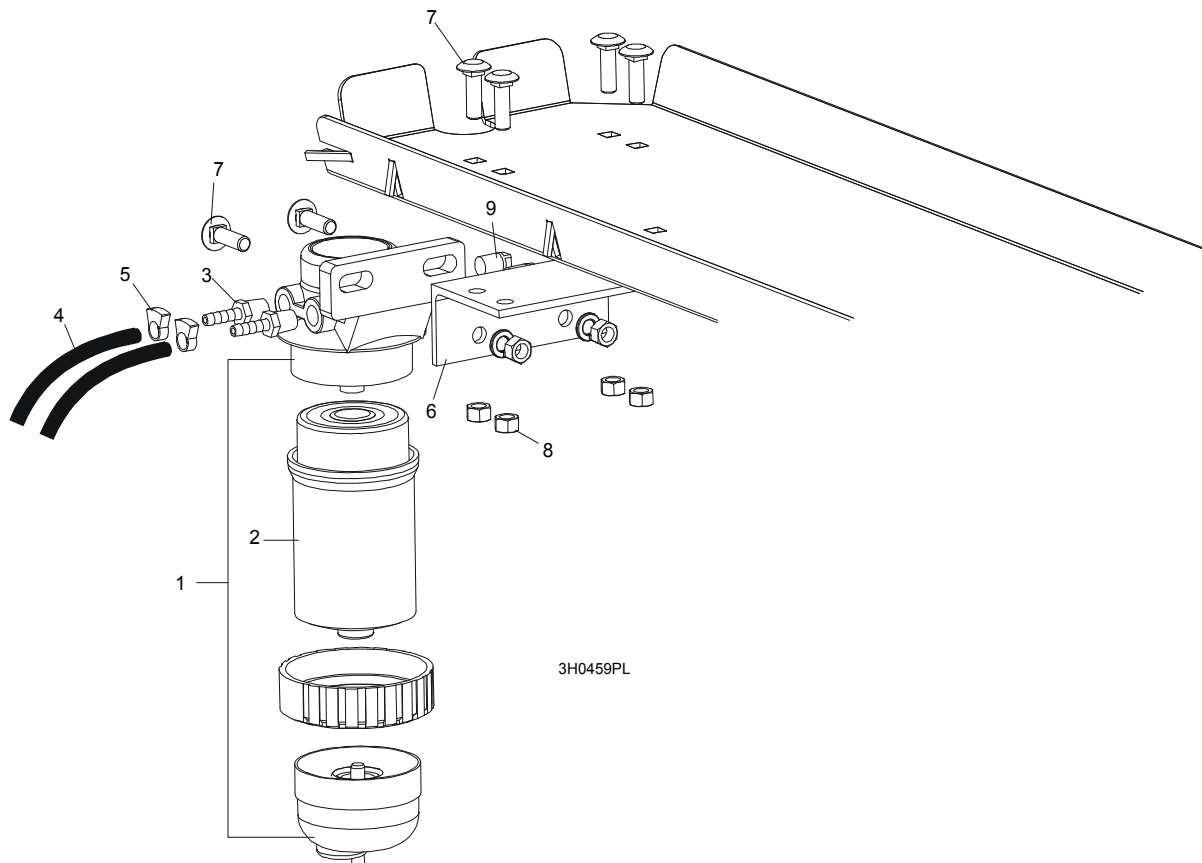

| REF | DESCRIPTION (◆ Indicates Parts Available In Assemblies Only) | PART # | QTY. | |
|-----|--|-----------|-------|--|
| | FILTER KIT, PRIMARY DIESEL FUEL | 015906 | 1 | |
| 1 | Filter Assembly, Standadyne Fuel #33816 | 015897 | 1 | |
| 2 | Filter, Standadyne Fuel Cartridge #31865 | 015898 | 1 | |
| 3 | Fitting, 1/4" NPT to 1/4" Hose Barb | P05393 | 2 | |
| 4 | Hose, 1/4" ID Fuel | P642 | 2.1 m | |
| 5 | Clamp, 7/32 - 1/2 Hose | F81080-1 | 2 | |
| 6 | Bracket, Diesel Fuel Filter Mount | 086086-1 | 1 | |
| 7 | Bolt, 3/8-16 x 1 1/4" Carriage Head | F05007-11 | 6 | |
| 8 | Nut, 3/8-16 Hex | F05010-10 | 6 | |
| 9 | Fitting, 1/4" NPT Plug | P05498 | 2 | |

4.7 Alternator Assembly

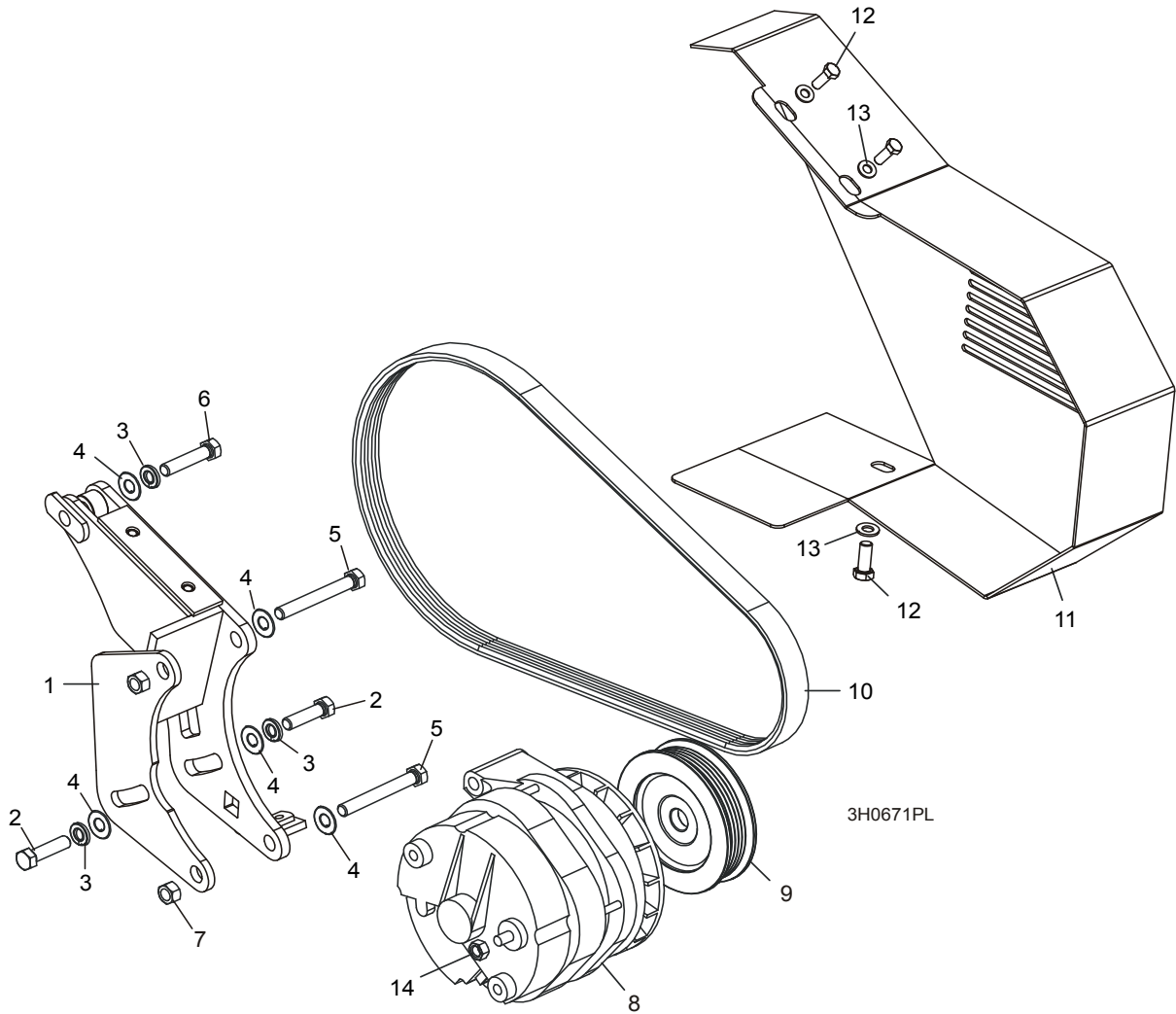

| j | Иъъ»—iX»Э (◆ ЫНѠБ°,ѠВЪ, ?ЪУ ?ѠТъё ФУТъѠ,ОяВЪТя ЪУОёНУ, Т-УльВ) | # ?ѠТЪЛ | юУО-, у | |
|---|--|-----------|------------|--|
| | WIRE ASSEMBLY, 61/140 AMP ALTERNATOR PLUG | 015969 | 1 | |
| | ALTERNATOR KIT, 140 AMP D40 | 023803 | 1 | |
| | Belt Guard Parts (See Section 4.16) | | | |
| 1 | Bracket Weldment, Alternator Mounting | 087215-1 | 1 | |
| 2 | Bolt, 3/8-16 x 3/4 Hex Head Full Thread | F05007-27 | 2 | |
| 3 | Washer, 10.2 Split Lock | F81055-2 | 3 | |
| 4 | Washer, 10.5 Flat | F81055-1 | 5 | |
| 5 | Bolt, M10 X 75-8.8 Hex Head | F81003-15 | 2 | |
| 6 | Bolt, 3/8-16 x 1 1/2" Hex Head | F05007-3 | 1 | |
| 7 | Nut, M10-8 Nylon Lock | F81033-1 | 3 | |

4 Replacement Parts

Alternator Assembly

| | | | | |
|-----------|---|-----------|---|---|
| | Block, Alternator Mount | 015331 | 1 | |
| | Alternator Assembly, 140 Amp | 023730 | 1 | |
| 8 | Alternator, 140 Amp | 023695 | 1 | ◆ |
| 9 | Pulley, 140 Amp Alternator | 023694 | 1 | |
| 10 | Belt, 6PK1090 Fiberglass | 087304 | 1 | |
| 11 | Guard Weldment, 140 Amp Alternator Belt | 087194-1 | 1 | |
| 12 | Bolt, M6 x 12-8.8 Hex Head | F81001-7 | 3 | |
| 13 | Washer, 6.5 Flat | F81053-11 | 3 | |
| 14 | NUT, M8 X 1.25 HEX JAM | F81032-5 | 1 | |

4.8 Relay/Throttle Assembly

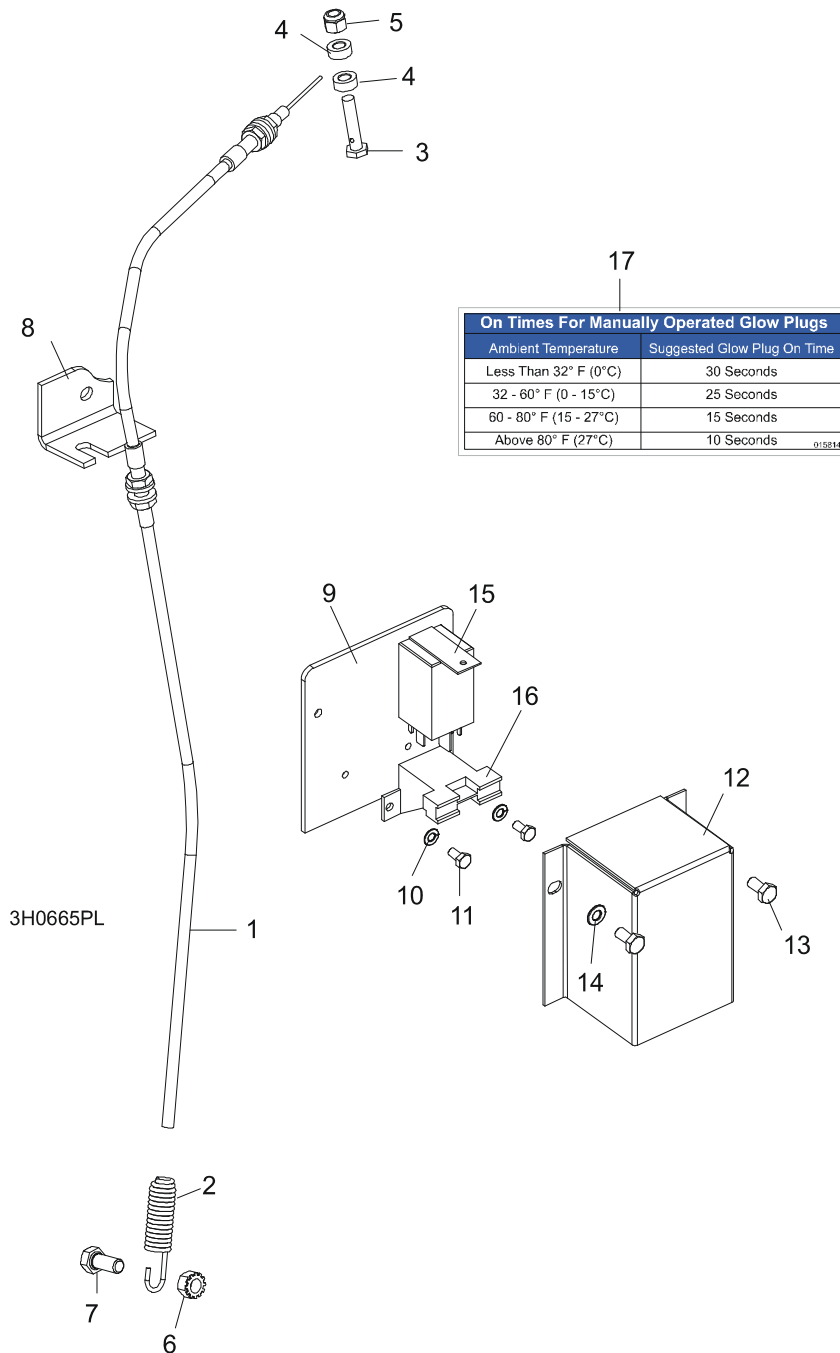

| REF | DESCRIPTION (◆ Indicates Parts Available In Assemblies Only) | PART # | QTY. |
|-----|--|--------|------|
| | CABLE ASSEMBLY, D30/D40 THROTTLE | 016125 | 1 |
| 1 | Cable, D30/D40 .078" Throttle | 016149 | 1 |
| 2 | Spring, Throttle | 016033 | 1 |

4**Replacement Parts***Relay/Throttle Assembly*

| | | | | |
|----|--|-----------|---|--|
| 3 | BOLT, D30/D40 THROTTLE CABLE | 015985 | 1 | |
| 4 | WASHER, .266 X .50 X .28" AL-BRONZE | 015986 | 2 | |
| 5 | NUT, 1/4-20 NYLON LOCK | F05010-69 | 1 | |
| 6 | NUT, M8-8 SELF-LOCKING HEX | F81032-1 | 1 | |
| 7 | BOLT, M8 X 20-8.8 HEX HEAD | F81002-4 | 1 | |
| 8 | BRACKET, THROTTLE CABLE MOUNT | 015566 | 1 | |
| 9 | PLATE WELDMENT, DIESEL RELAY BOX MOUNT | 086236-1 | 1 | |
| 10 | WASHER, 5.3 SPLIT LOCK | F81052-1 | 2 | |
| 11 | BOLT, M5 X 12-5.8 HEX HEAD | F81000-5 | 2 | |
| 12 | BOX, D40 GLOW PLUG RELAY | 014199 | 1 | |
| 13 | BOLT, M6 X 12-8.8 SLOTTED HEX HEAD | F81001-7 | 2 | |
| 14 | WASHER, 6.4 FLAT | F81053-1 | 2 | |
| 15 | RELAY, GLOW PLUG | 023359 | 1 | |
| 16 | SOCKET, GLOW PLUG RELAY + TERMINAL KIT | 023358 | 1 | |
| | TERMINAL, 1/4" QUICK 14-16GA FI | F05708-3 | 5 | |
| | FLAG TERMINAL 12GA FI | F05708-4 | 1 | |
| 17 | DECAL, LOMBARDINI GLOW PLUG ON TIME (LOCATED ON CONTROL BOX) | 015814 | 1 | |

4.9 Muffler Assembly

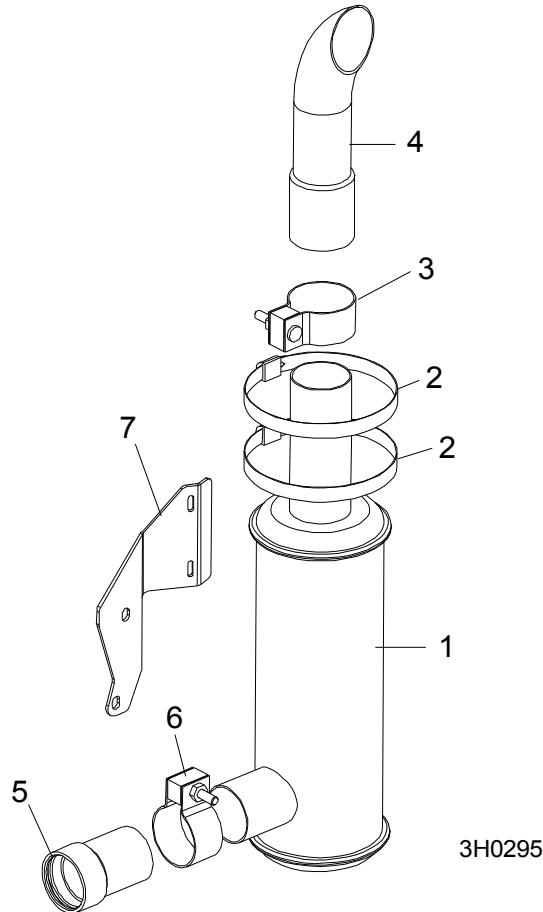

| REF | DESCRIPTION (◆ Indicates Parts Available In Assemblies Only) | PART # | QTY. |
|-----|--|--------|------|
| 1 | MUFFLER, DIESEL | 014093 | 1 |
| 2 | CLAMP, 5" WORM | 014096 | 2 |
| 3 | CLAMP, MUFFLER | 014095 | 1 |
| 4 | STACK, DIESEL MUFFLER | 014094 | 1 |
| 5 | TUBE, LOMBARDINI EXHAUST | 014319 | 1 |
| 6 | CLAMP, MUFFLER 2" NELSON 90869A | 014205 | 1 |
| 7 | BRACKET, MUFFLER | 014321 | 1 |

4 Replacement Parts

Drive Assembly

4.10 Drive Assembly

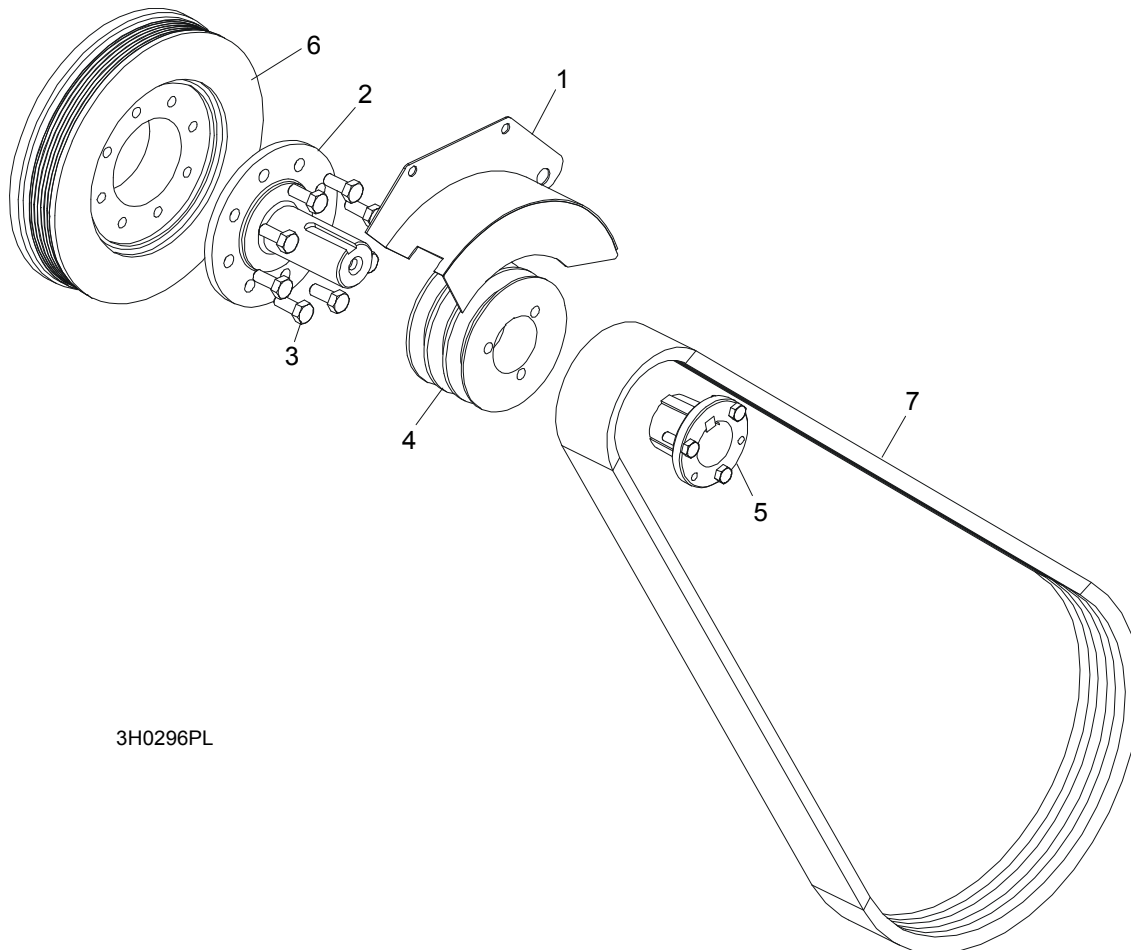

| REF | DESCRIPTION (◆ Indicates Parts Available In Assemblies Only) | PART # | QTY. |
|-----|--|-----------|------|
| 1 | COVER WELDMENT, FLYWHEEL | 086785 | 1 |
| 2 | SHAFT, OUTPUT | 086329 | 1 |
| 3 | BOLT, M10X25 GRADE 10.9 HEX HEAD | F05009-52 | 8 |
| 4 | SHEAVE, 3TB42 MOTOR DRIVE | 014007 | 1 |
| 5 | BUSHING, SPLIT TAPER, P1 1 9/16" | 014003 | 1 |
| 6 | FLYWHEEL, ALTERNATOR BELT | 015309 | 1 |
| 7 | BELT, 3BX72 | 014085 | 1 |
| | SUPPORT, D30/D40/E25 DRIVE BELT UPPER | 085865-1 | 1 |
| | SUPPORT, D30/D40/E25 DRIVE BELT LOWER | 085922-1 | 1 |

4.11 Radiator Assembly

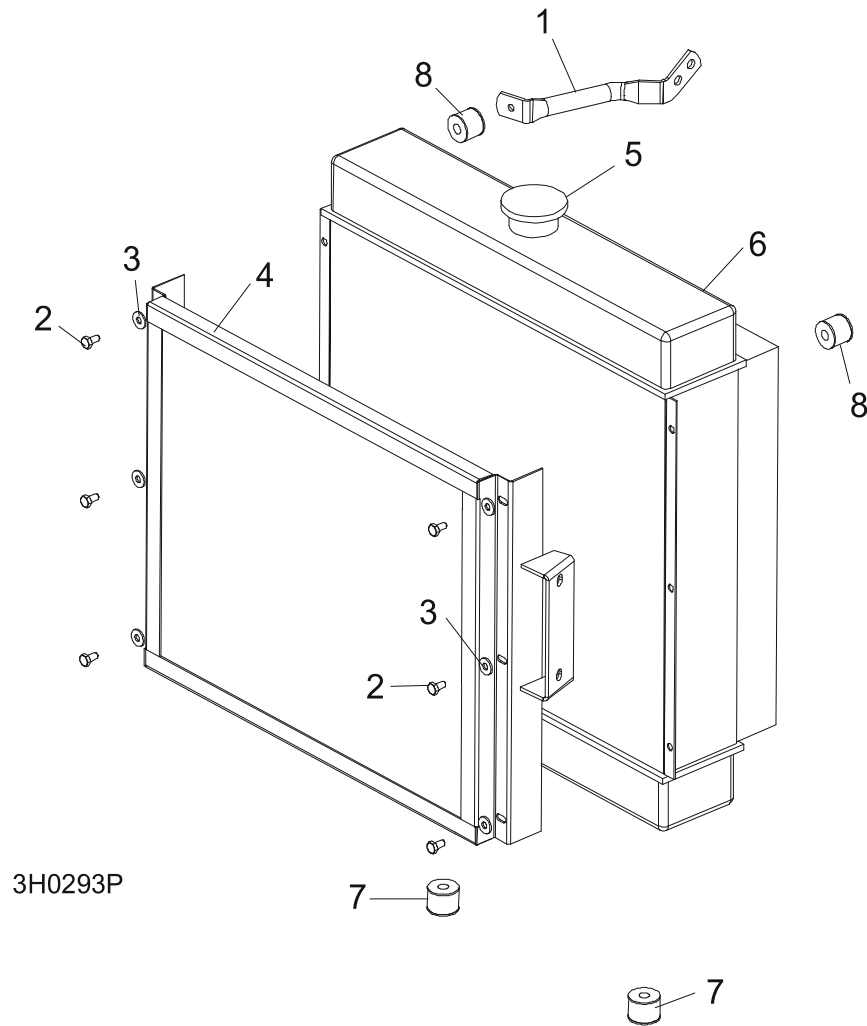

| REF | DESCRIPTION (◆ Indicates Parts Available In Assemblies Only) | PART # | QTY. |
|-----|--|----------|------|
| 1 | BRACE, LOMBARDINI RADIATOR LEFT SUPPORT 9265-162 | 016171 | 1 |
| 2 | SCREW, M6 X 12-8.8 HEX HEAD CAP FULL THREAD | F81001-7 | 6 |
| 3 | WASHER, 7.4 FLAT | F81056-1 | 6 |
| 4 | GRILL, RADIATOR | 087071-1 | 1 |
| 5 | CAP, RADIATOR FILL | 014295 | 1 |
| 6 | RADIATOR, LOMBARDINI | 014291 | 1 |
| 7 | BUSHING, RADIATOR VIBRATION LOWER | 016143 | 2 |
| 8 | BUSHING, RADIATOR VIBRATION UPPER | 016144 | 2 |

4 Replacement Parts

Engine/Muffler Guards

4.12 Engine/Muffler Guards

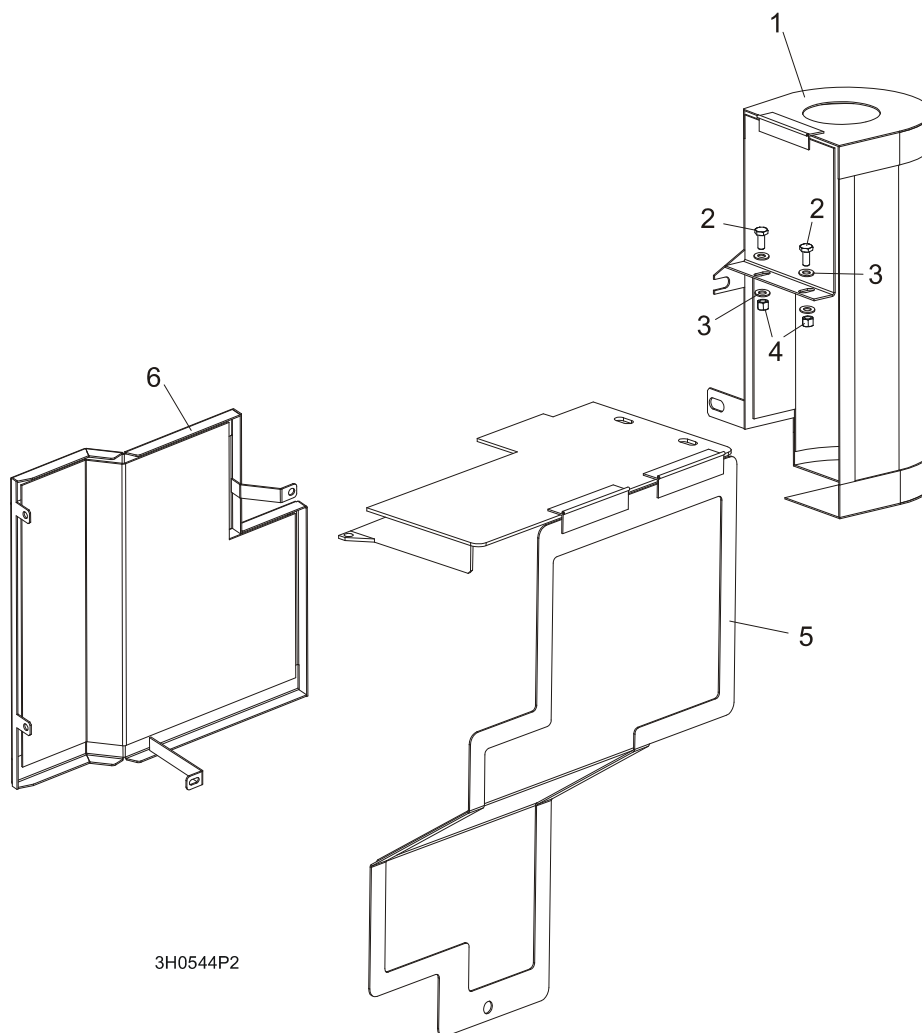

| REF | DESCRIPTION (◆ Indicates Parts Available In Assemblies Only) | PART # | QTY. |
|-----|--|-----------|------|
| 1 | GUARD, D38/D40 MUFFLER | 085855-1 | 1 |
| 2 | BOLT, M10 X 25-8.8 HEX HEAD | F81003-11 | 2 |
| 3 | WASHER, 10.5 FLAT | F81055-1 | 4 |
| 4 | NUT, M10-8 NYLON LOCK | F81033-1 | 2 |
| 5 | GUARD, D38/D40 SIDE ENGINE | 085852-1 | 1 |
| 6 | GUARD, D30/D38/D40 LEFT SIDE | 086027-1 | 1 |

4.13 Engine Pulley Guards

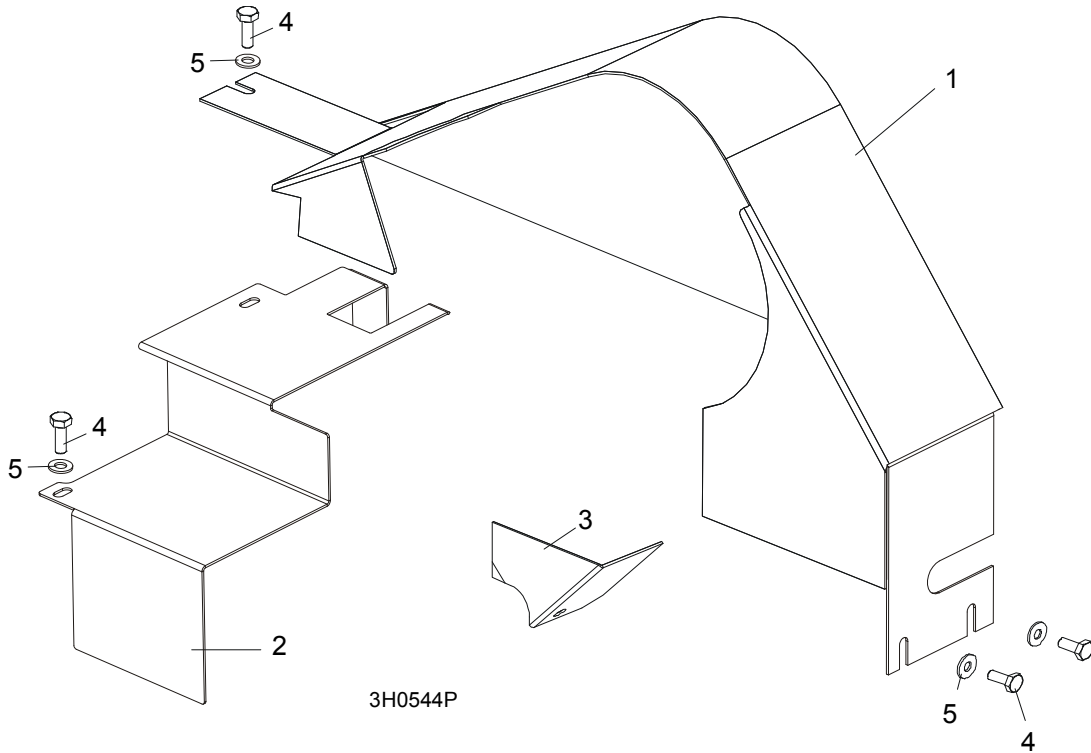

| REF | DESCRIPTION (◆ Indicates Parts Available In Assemblies Only) | PART # | QTY. | |
|-----|--|-----------|------|--|
| 1 | GUARD WELDMENT, D40 ENGINE PULLEY | 086043-1 | 1 | |
| 2 | GUARD, D40 SIDE ENGINE PULLEY | 086403-1 | 1 | |
| 3 | GUARD, D40 BOTTOM ENGINE PULLEY | 015158 | 1 | |
| 4 | BOLT, M6 X 20-8.8 HEX HEAD | F81001-2 | 3 | |
| 5 | WASHER, 6.5 FLAT | F81053-11 | 3 | |

4 Replacement Parts

Air Cleaner Assembly

4.14 Air Cleaner Assembly

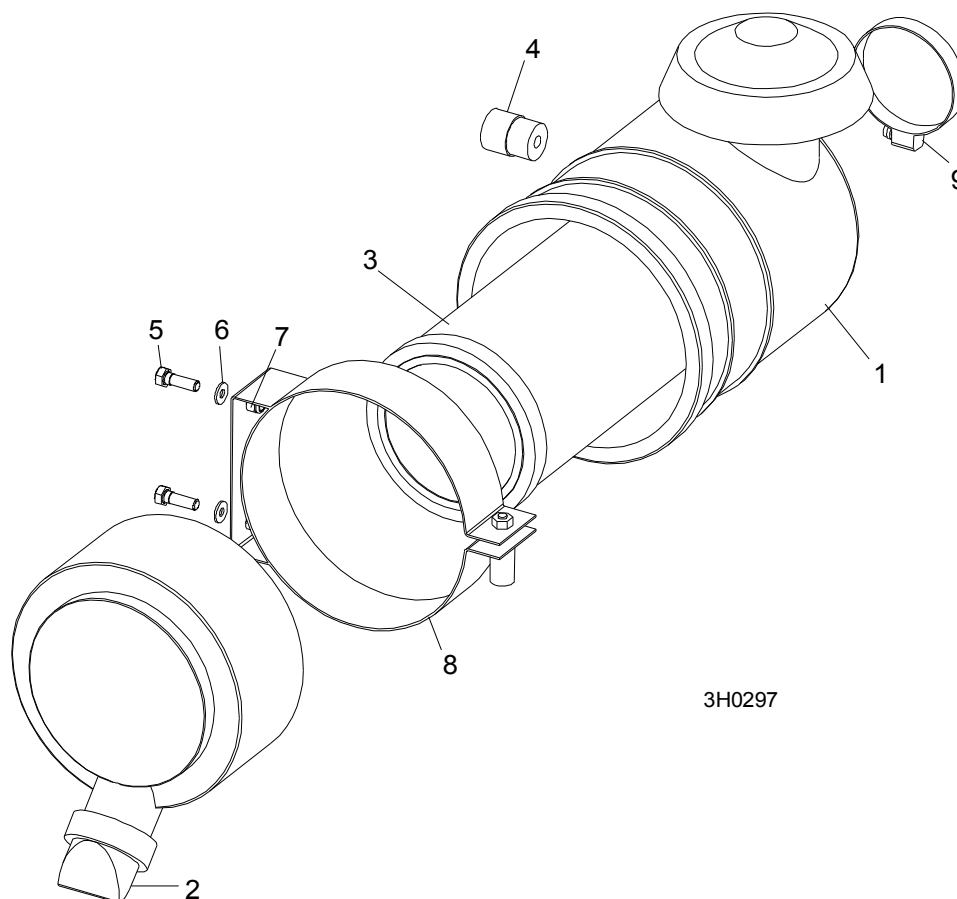

| REF | DESCRIPTION (◆ Indicates Parts Available In Assemblies Only) | PART # | QTY. |
|-----|--|----------|------|
| 1 | CLEANER ASSEMBLY, DONALDSON AIR COMPLETE | 014280 | 1 |
| 2 | Boot, Air Cleaner Evacuator | 014287 | 1 |
| 3 | Element, Donaldson Air Filter | 014210 | 1 |
| 4 | INDICATOR, AIR CLEANER RESTRICTION | 014336 | 1 |
| 5 | BOLT, M8 X 20-8.8 HEX HEAD | F81002-4 | 2 |
| 6 | WASHER, 8.4 SAE FLAT | F81054-1 | 2 |
| 7 | NUT, M8-8 HEX NYLON LOCK | F81032-2 | 2 |
| 8 | CLAMP, 7" SPRING | 014160 | 1 |
| 9 | CLAMP, 75-95MM HOSE | F81080-2 | 1 |

SECTION 5 ELECTRICAL INFORMATION

5.1 Electrical Symbol Diagram, Super D40

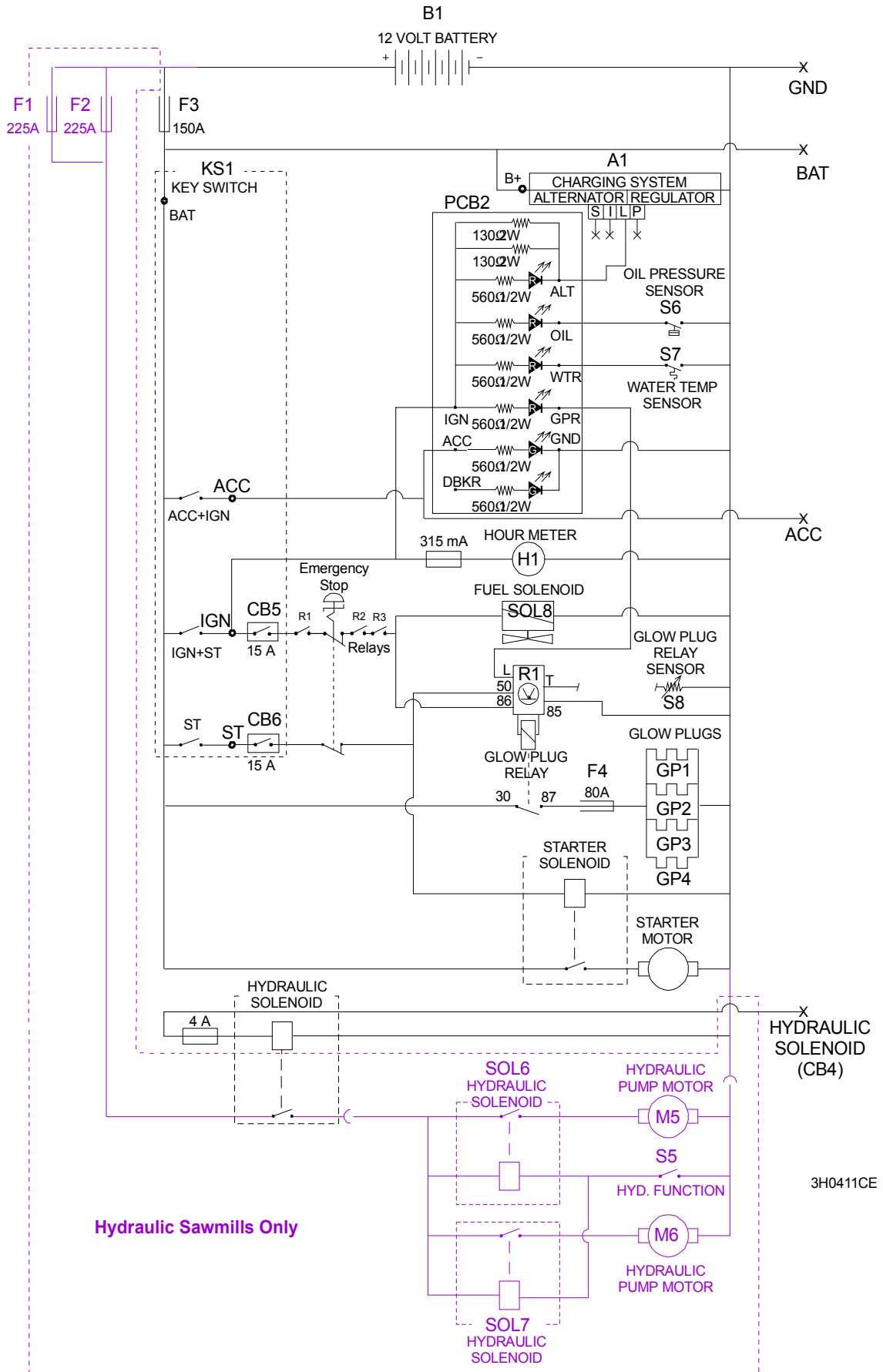
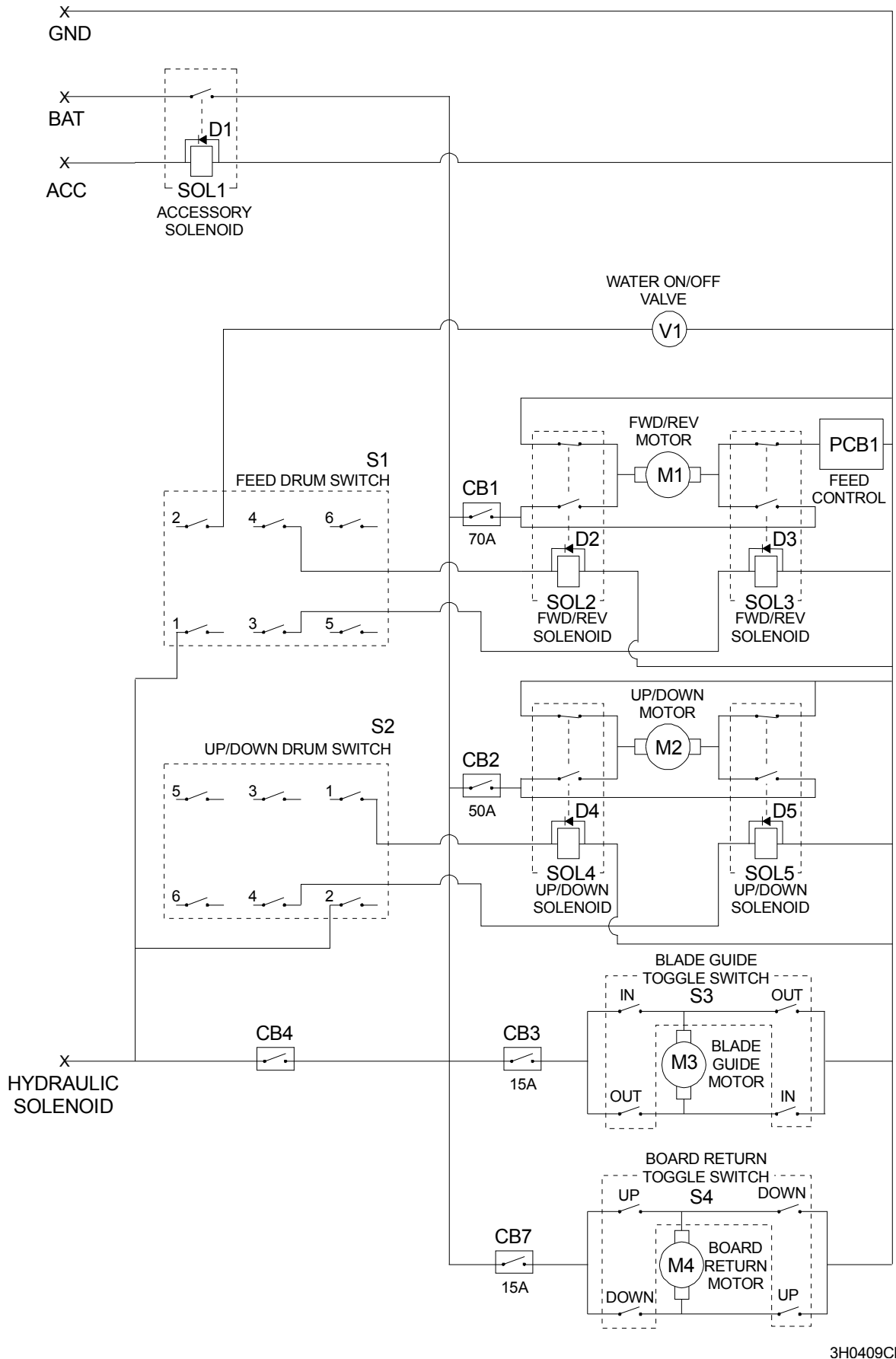

FIG. 5-1 D40 SYMBOL DIAGRAM (PAGE 1 OF 2).



3H0409CE

FIG. 5-2 D40 SYMBOL DIAGRAM (PAGE 1 OF 2).

5.2 Electrical Components, Super D40

| Item | Mfg. Part No. | Mfg. | Wood-Mizer Part No. | Description |
|---------------------|------------------|-------------------|---------------------|--|
| A1 | 10480168 | Delco-Remy | 015473 | Alternator, 105 Amp |
| B1 | 1231PMF | BOSCH | 015475 | Battery, 12 Volt (See Section 5.3) |
| CB1 | 70-1648-009 | Mech. Prod. | 015527 | Breaker, 70 Amp Manual Reset Panel Mount, Power Feed |
| CB2 ¹ | 1648-009-050-006 | Mech. Prod. | 021256 | Breaker, 50 Amp Manual Reset Panel Mount, Up/Down |
| | CH-30407-50 | Cole-Hersee | E20432 | Circuit Breaker, 50 Amp 12 Volt, Manual Reset |
| CB3 ² | CH30407-15 | Cole-Hersee | E20430 | Breaker, 15 Amp Manual Reset, Blade Guide |
| CB4 ² | CH30407-15 | Cole-Hersee | E20430 | Breaker, 15 Amp Manual Reset, Accessory |
| CB5 ² | CH30407-15 | Cole-Hersee | E20430 | Breaker, 15 Amp Manual Reset, Ignition |
| CB6 ² | CH30407-15 | Cole-Hersee | E20430 | Breaker, 15 Amp Manual Reset, Start |
| CB7 ² | CH30407-15 | Cole-Hersee | E20430 | Breaker, 15 Amp Manual Reset, Board Return |
| CB10 ³ | 024453 | Wood-Mizer | 024453 | Breaker Assy, Water Temp Max Circuit |
| D1 - D5 | 015426 | Wood-Mizer | 015426 | Diode Assembly, Solenoid Coil Chassis |
| D7 | 024123 | Wood-Mizer | 024123 | Diode Assembly, Inductive Kick Protection |
| F1, F2 ⁴ | RL-225 | Gould | P11550 | Fuse Link, 225 Amp, 250 Volt For Hydraulic + 12 Volt Circuit |
| F3 | RL-150 | Gould | 023361 | Fuse Link, 150A 250V For Main + 12 Volt Starter, Alternator |
| F4 | 4062-232 | Lombardini | 014350 | Fuse Link, 80 Amp Lombardini Glow Plug |
| GP1-GP4 | 2100-072 | Lombardini | 014278 | Glow Plug |
| H1 | T14BH517BC9 | ENM Corp. | 015401 | Hour Meter, 12 Volt, Low Power T14 Series |
| KS1 | 121801 | General | P04350 | Key Switch, 4-position (Accessory, Off, Ignition, Start) |
| M1 | 108677.00 | Leeson | 024169 ⁵ | Motor, 3/4HP 12VDC TEFC Power Feed w/o Base |
| M2 | 108678.00 | Leeson | 015174 | Motor, 3/4HP 12VDC TEFC Up/Down w/Base |
| M3 | P09698-1 | Klauber | A10365 | Motor, 12 Volt Blade Guide Arm 53:1 Gear |
| M4 | P09698-1 | Klauber | A10365 | Motor, 12 Volt Board Return 53:1 Gear |
| M5, M6 ⁴ | 8111 | Monarch | P09955 | Motor, 12 Volt Hydraulic Pump |
| P1 | 015408 | Wood-Mizer | 015408 | Potentiometer, Variable Resistance Power Feed |
| PCB1 | 015410 | Wood-Mizer | 015410 | Circuit Board, Control Box Power Feed |
| PCB2 | 015409 | Wood-Mizer | 015409 | Board, LED Circuit (Diesel) |
| R1 | 2193-084 | Lombardini | 023359 | Relay, Glow Plug Timer |
| S1 | 2601-AF2-S11 | Square D | E20438 | Drum Switch, Power Feed Fwd/Reverse Motor |
| S2 | 2601-AF2-S12 | Square D | E20440 | Drum Switch, Up/Down Motor |
| S3 ⁶ | 34-591Q | Pollak | 024200 | Toggle Switch, Blade Guide In/Out Motor |
| | 1121-0004 | McGill | P10006 | Toggle Switch, Blade Guide In/Out Motor |
| S4 ⁶ | 34-591Q | Pollak | 024200 | Toggle Switch, Board Return Motor |
| | 1121-0004 | McGill | P10006 | Toggle Switch, Board Return Motor |
| S5 ⁴ | 024198 | Wood-Mizer | 024198 ⁷ | Switch, Hydraulic Pump Levers |

TABLE 5-1

| | | | | |
|--|--------------|------------|----------|---|
| S6 | -- | -- | 014557 | Switch Kit, Oil Pressure Sending |
| | 6745-044 | Lombardini | 014290 | Switch, Oil Pressure Sending |
| | 4670-060 | Lombardini | 014554 | Gasket, Copper Oil Pressure |
| S7 | -- | -- | 014558 | Switch Kit, Water Temperature Sending |
| | 9195-077 | Lombardini | 014351 | Switch, Water Temperature Sending |
| | 4670-019 | Lombardini | 014555 | Gasket, Copper Water Temperature |
| S8 ⁸ | -- | -- | 014559 | Switch Kit, Glow Plug Temperature Sending |
| | 9195-067 | Lombardini | 014352 | Switch, Glow Plug Temperature Sending |
| | 4670-061 | Lombardini | 014556 | Gasket, Copper Glow Plug Temperature |
| SOL1 | 120-943 | Stancor | P10449 | Solenoid, Accessory Circuit |
| SOL2-SOL5 | 586-911 | Stancor | 015417 | Solenoid, 200A 12V DPST |
| SOL6,SOL7, SOL10 ⁴ | 586-902 | Stancor | 015470 | Solenoid, 200A 12V SPST Hydraulic Pump Motor |
| SOL8 | 3587-119 | Lombardini | 014279 | Solenoid, Fuel |
| V1 | S24C-6V12VDC | Atkomatic | 014165 | Valve, Waterlube Solenoid |
| VR1 | 015408 | Wood-Mizer | 024450-1 | Potentiometer, Variable Resistance Power Feed |

TABLE 5-1

¹ Use panel mount breaker 021256 for LT30 Super Rev. G3.00+, LT40 Super Rev. G4.00+, LT30HD Super and LT40HD Super Rev. G7.00+. Use interior breaker E20432 for LT30 Super Rev. F7.00 - G2.01, LT40 Super Rev. F8.00 - G3.01, LT30HD Super and LT40HD Super Rev. G1.00 - G6.01.

² CB3 - CB7 applies to LT30 Super Rev. G3.00+, LT40 Super Rev. G4.00+. LT30HD and LT40HD Super Rev. G7.00+ only.

³ Circuit breaker assembly added on LT30 Super Rev. G4.01, LT40 Super Rev. G5.01 and LT30HD/40HD Super Rev. G8.01.

⁴ Component applies to hydraulic models only. Solenoid (SOL10) added LT30HD Super and LT40HD Super Rev. G8.00.

⁵ Use 024169 motor without mounting base to service Super power feed systems.

⁶ Use 024200 for LT30 Super Rev. F9.00, LT40 Super Rev. G1.00, LT30HD/40HD Super Rev. G3.00 and later. Use P10006 toggle switch for previous revision mills.

⁷ Saleable service assembly created which includes 014765 3-wire switch and crimped terminals (7/97). 014765 3-wire switch directly replaces P12735 2-wire switch (4/97).

⁸ Glow plug sensing relay disconnected on LT30 Super Rev. F9.00, LT40 Super Rev. G1.00, LT30HD Super and LT40HD Super Rev. G3.00 to provide manual control of glow plug operation. Previous revisions can be modified to improve hot starting performance ([See form 250](#)). [See Section 2.1](#) for manual glow plug on time recommendations.

5.3 Battery Specifications, Super D40

| Group No. | Type No. | Performance Level | | Approx. Weight (Wet) | Maximum Overall Dimensions | | |
|-----------|----------|----------------------|------------------|----------------------|----------------------------|--------------------|--------------------|
| | | Cranking Performance | Reserve Capacity | | Length | Width | Height |
| 31 | 1231PMF | 1100 | 195 | 60 lb. (27.2 Kg) | 13" (330 mm) | 6 3/4" (171 mm) | 9 1/2" (241 mm) |

TABLE 5-2

5.4 Electrical Wiring Diagram, D40

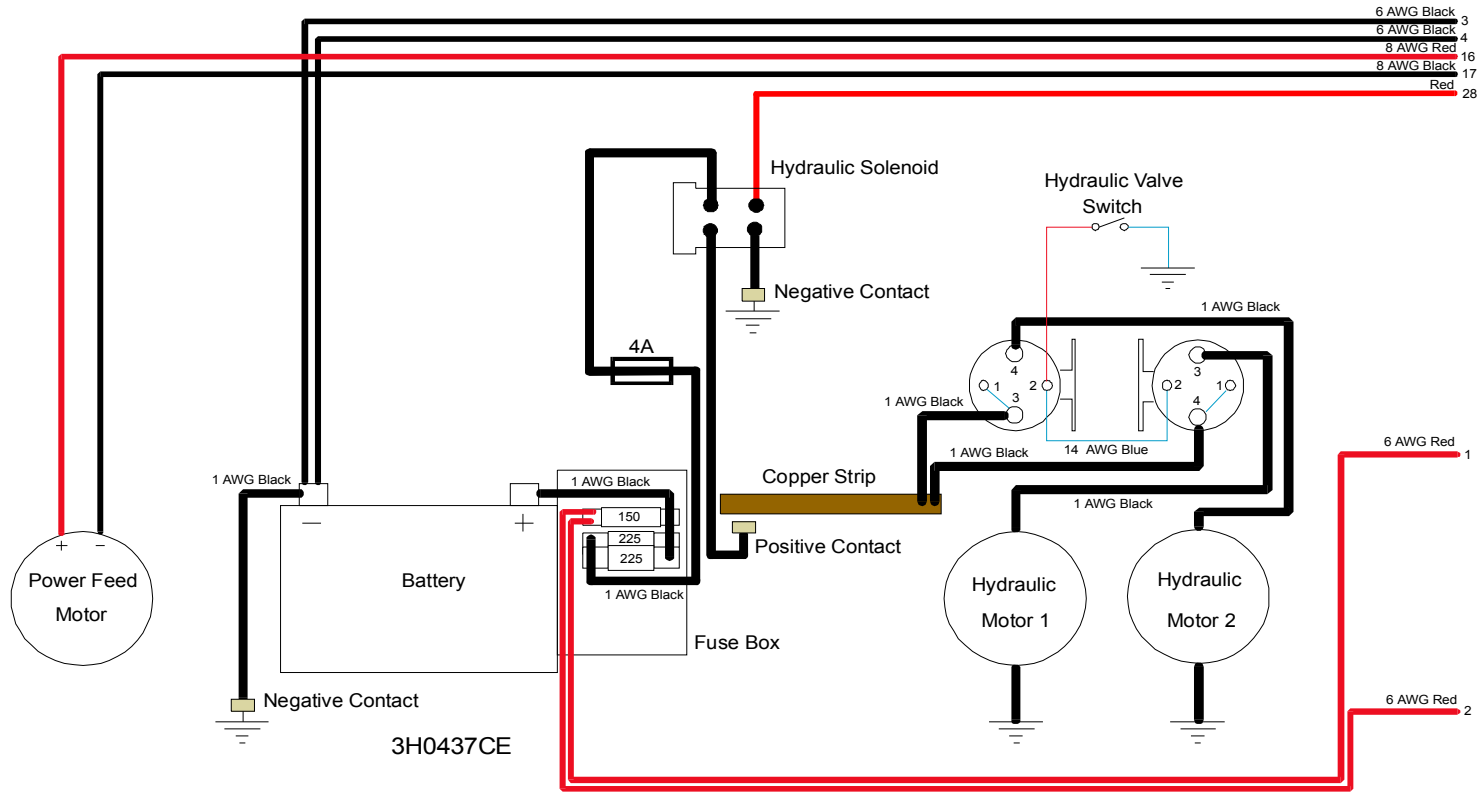
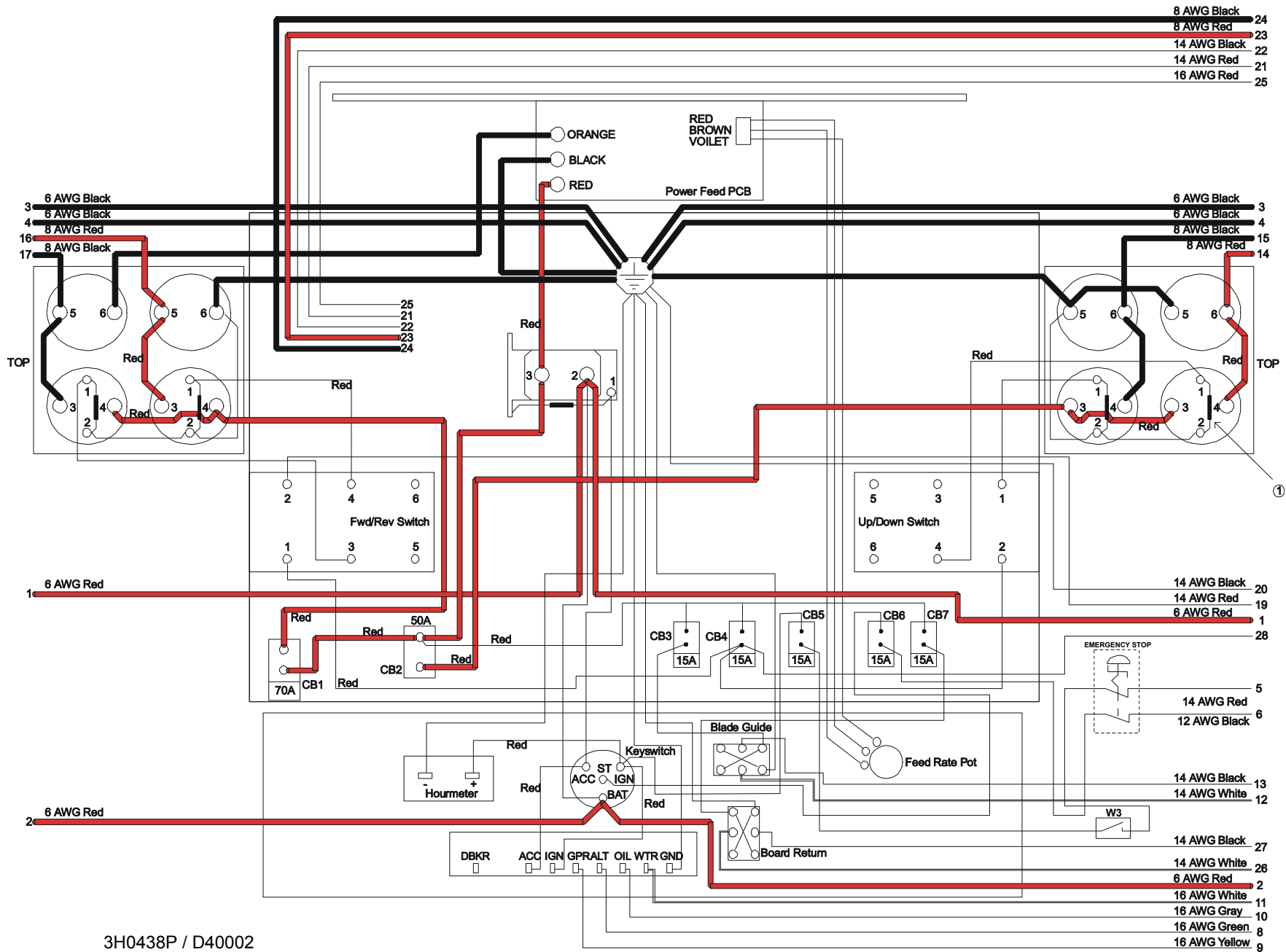

FIG. 5-3 D40 WIRING DIAGRAM (PAGE 1 OF 3).



3H0438P / D40002

FIG. 5-4 D40 WIRING DIAGRAM (PAGE 2 OF 3).

