



user manual

Instrukcja obsługi | Руководство пользователя
Manuel de l'Utilisateur | Betriebsanweisung
Bruksanvisning | Manual del Usuario
Betjeningsvejledning | Gebruikershandleiding
Käyttöohjeet | Manual de utilizare | Bruksanvisning
Manuale d'uso | Příručka uživatele | Navodila
za uporabo

Retain for future use
Zachować do przyszłego użytku
Сохраните для последующего
использования
A conserver pour une utilisation future
Für zukünftige Benutzung aufbewahren
Behold for senere bruk
Säilytä nämä käyttöohjeet tulevaa tarvetta marten
Opbevar manualen til fremtidig brug
Bewaren voor gebruik in de toekomst
Conservare il presente manuale a l'uso futuro
Păstrați acest manual pentru utilizare viitoare
Conservar para futuras consultas
Behåll för framtida användning
Uchovejte pro další použití
Hranite za prihodnjo uporabo

SW-10 NETWORKS

Operation & Parts Manual

LT20 SW-10 Networks	rev.A1.00
LT40 SW-10 Networks	rev. A1.00
WM1000 SW-10 Networks	rev. A1.00



Safety is our #1 concern! Read and understand all safety information and instructions before operating, setting up or maintaining this machine.

June 2009

Form #645

Table of Contents

Section-Page

SECTION 1	OPERATION	1-1
1.1	SW-10 Controller Panel	1-1
1.2	Start-up Settings of the Controller.....	1-3
1.3	Operation in Normal Mode	1-7
1.4	Controller Operation in Pre-defined Head Return Height Mode	1-8
1.5	Remote Mode	1-10
1.6	Pattern Modes.....	1-11
	<i>"Manual Program" Mode</i>	
	<i>"Quick Program" Mode</i>	
	<i>Storing Programs in the Setworks Memory</i>	
SECTION 2	TROUBLESHOOTING	2-1
2.1	Setworks Malfunction	2-1
SECTION 3	REPLACEMENT PARTS	3-1
3.1	How To Use The Parts List	3-1
3.2	Sample Assembly	3-1
3.3	SW-10 Setworks for LT20 Series Sawmills.....	3-2
3.4	SW-10 Setworks for LT40 Series Sawmills.....	3-4
3.5	SW-10 Setworks for WM1000 Sawmills	3-6

SECTION 1 OPERATION

1.1 SW-10 Controller Panel

See Figure 1-1.

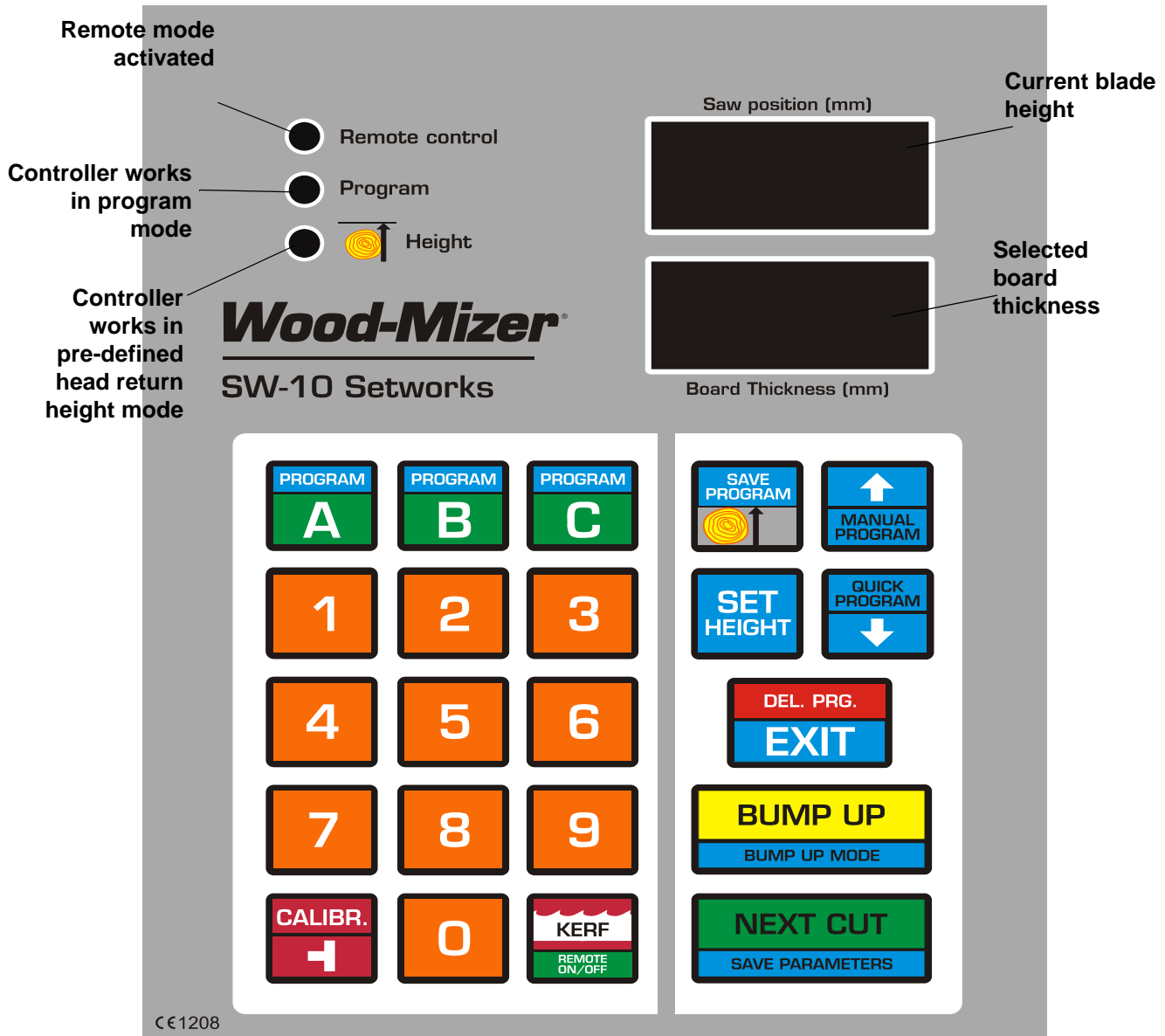

FIGURE 1-1

Descriptions of the controller panel buttons:



A, B, C - Board thickness memory buttons, program memory buttons



SAVE PROG - confirming a program, setting a head return height.



MANUAL PROGRAM - activating the Manual Program mode, switching items upwards



QUICK PROGRAM - activating the Quick Program mode, switching items downwards



SET HEIGHT - entering a real distance between the blade and the sawmill bed.



DEL. PRG./EXIT - deleting a previously stored program, exiting an active function.



BUMP UP MODE – Bump Up function: Automatically moves the saw head up to clear the log or cant when it is returned. You can choose between two, permanently defined Bump Up values.



NEXT CUT– automatic head downward movement (to next cut height), storing entered values.



KERF - setting blade kerf value, activating/disabling the Remote mode.





CALIBR – activating the auto-calibration mode, entering the input divider value.

NOTE: Do not use any hard objects, or too much force, to press the controller buttons.

NOTE: Protect the controller keypad against precipitations and sunbeams. Clean it with a soft rag and mild cleaners.

1.2 Start-up Settings of the Controller

1. Setting the Input Divider (entered only once, at the first start-up)

- Switch on the controller.
- When the text “SW-10” appears on the display, press and hold  until the divider value appears on the lower display.
- Enter the correct value of the divider (depending on the up/down system of the machine) using the keypad (for LT15 sawmills, the divider value should be **20**, for LT20, LT40 and WM1000 sawmills, the divider value should be **5**).
- Press  to save the entered divider value.
- „**SAVE**” will appear in the display window.

2. Entering the Blade Kerf Thickness

On initial start-up or after replacement of the blade with another one with a different thickness or different tooth set, the kerf value should be entered.

- Press and hold  until the small zero and the current kerf setting appear on the lower display.
- Enter the kerf value.

NOTE: We recommend using Wood-Mizer blades only. For the Wood-Mizer blades, the kerf value should be 2mm, so you should press “2” and “0” buttons.

Kerf values with an accuracy of up to 0.1 mm can be entered into the memory of SW-10 Setworks.

See Figure 1-2.

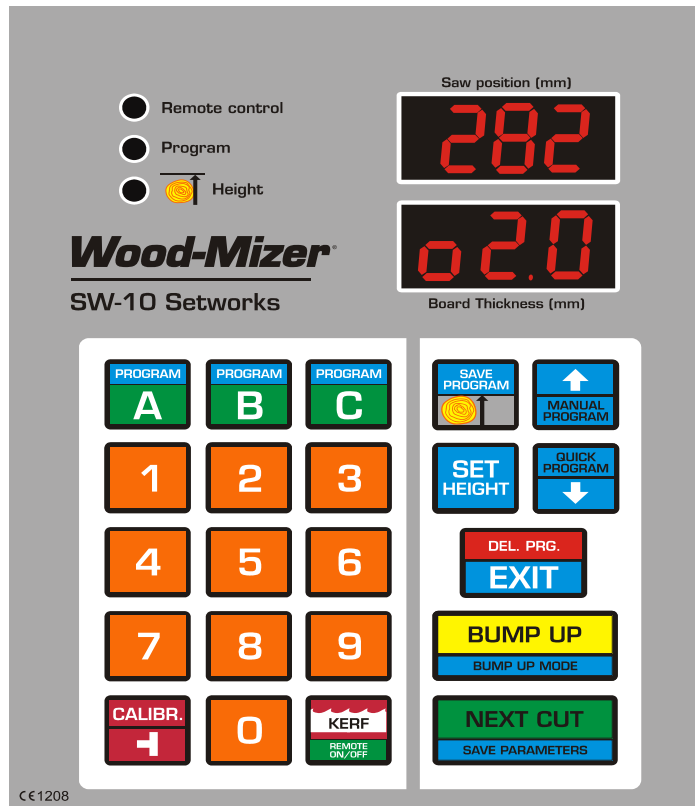

FIGURE 1-2

- To save the kerf value setting, press . The controller will display the text “SAVE” and will exit the function.

NOTE: From this moment, the Setworks controller will be calculating next cutting positions taking into account the stored kerf value. Therefore, it will not be necessary to correct the head height manually during cutting.

3. Auto-calibration

This function should be used in case of:

- [LT15 sawmills] Replacement of the up-down system screw or motor, after lubrication of the screws and other moving parts of the head as well as when significant cutting variances are observed;
- [LT20, LT40 and WM1000 sawmills] If difference between the blade height shown on the upper display and the real dimension from the bed rail level is observed.
- [all sawmills] If the sawmill is operated in conditions of large air temperature fluctuations, perform the automatic calibration twice a week.

- Switch on the controller and wait until the text "SW-10" disappears.
- Set the head with the blade at the height of 150 mm.
- Press and hold down . The text "Auto CALL" will appear on the display. The controller is now ready for auto-calibration.

See Figure 1-3.

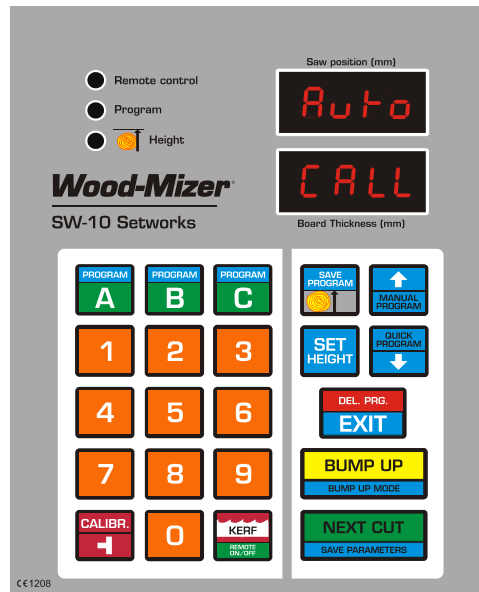



FIGURE 1-3

- Press . The controller will perform two downward head movements and then nine upward movements. After the last movement, "End Call" will be shown in the display window.

NOTE: It is recommended that the auto-calibration procedure should be performed every 25 hours of operation or twice a week to ensure the highest possible sawing accuracy.

NOTE: If, during the downward movement, the saw head hits the stop bolt, set the head a little higher than previously and repeat the auto-calibration procedure.

4. Entering Real Blade Height Dimensions

- Check if the blade height shown on the display is correct. To do that, use the blade height scale on the sawmill or measure the distance between the blade and the sawmill bed.

- If the blade height on the display is incorrect, press and hold down . The upper display will show horizontal dashes. Enter the correct blade height dimension (using the keypad) and press





- The end of the function will be signaled and the normal mode of operation will be restored.

NOTE: If, during the downward movement, the saw head hits the stop bolt, set the head a little higher than previously and repeat the auto-calibration procedure.

5. Setting a Head Return Height in BUMP UP Function



It is possible to program two modes of head return height that are available during cutting (LO and HI modes) by using the  button.

In the usual, LO mode, after pushing , the blade is raised above the material being sawn, by a permanently defined value - ca. 12 mm. When this mode is used, each cut board should be removed before returning the head to the front of the bed.

In the HI mode, after pressing , the blade is raised by 12 mm + last used board dimension. For example, if the last cut board is 25 mm thick, the saw head will be raised by 37 mm (12mm + 25mm). When using this mode, the operator can return the head to the front of the machine without earlier board removal.

The controller is factory-set for operation in the usual, LO mode.

To change or check the operation mode:

- Turn off power supply to the controller. Wait about 3 seconds and turn it on.
- While "SW-10" is being displayed, press and hold down the  button for about 3 seconds.
- On the upper display the active operation mode is shown.
- To change the operation mode, use  and .

- To save the parameter, push .

1.3 Operation in Normal Mode



CAUTION! The minimum thickness of the last board (when using the automatic modes) cannot be lower than **30 mm** [LT15, LT20 and WM1000 sawmills] or **50mm** [LT40 sawmills]. To cut a thinner board, you need to manually lower the saw head.

After switching-on, the "SW-10" inscription appears on the display, and the Setworks is ready for operation within a few seconds. The last used board thickness is displayed.

- To change the board thickness, enter the new thickness required using the keypad. Press



. The saw head will move down by the preset value (taking into account the kerf value).

- The controller panel includes three buttons labeled A, B and C. They are used to store board thicknesses. To display value stored under any of these buttons, press this button momentarily.
- To change the stored setting for any of the three buttons, first turn off power supply to the controller and then turn it on. When "SW-10" appears on the display, press and hold down this button. The display will show "Abc" and horizontal dashes. Push the chosen board thickness memory button (A, B or C) and enter the desired board thickness using the keypad. If you need to store more board thickness dimensions, press another board thickness memory button and enter this dimension. After entering all needed dimensions, confirm this by pressing . The display should show "Save" confirming that the changes have been stored.

- Position the saw head at the height of the first cut calculated from the top of the log.
- Start cutting the material to the required dimension.
- Remove the board.
- Having completed a cut, press ; the head will automatically go up by the Bump Up value so that it clears the log or cant when being returned.
- If needed, change the required board thickness dimension using the keypad or values stored under the remaining board thickness memory buttons.

- Press  and the saw head will drop by the pre-set board thickness to **the next cut**

position.

Only the first cut position has to be set manually.

NOTE: After making the first cut you will not need to set the head height manually.

1.4 Controller Operation in Pre-defined Head Return Height Mode

If you want to saw without removing each cut board, you should preprogram the head return height. It is possible to program two head return height values (See Point 5. Setting a Head Return Height in BUMP UP Function).

Programming the head return height:

- Position the head above the log or cant so that it clears the log/cant when being returned.
- Press and hold  until the lamp shown on the picture below starts lighting.

See Figure 1-4.

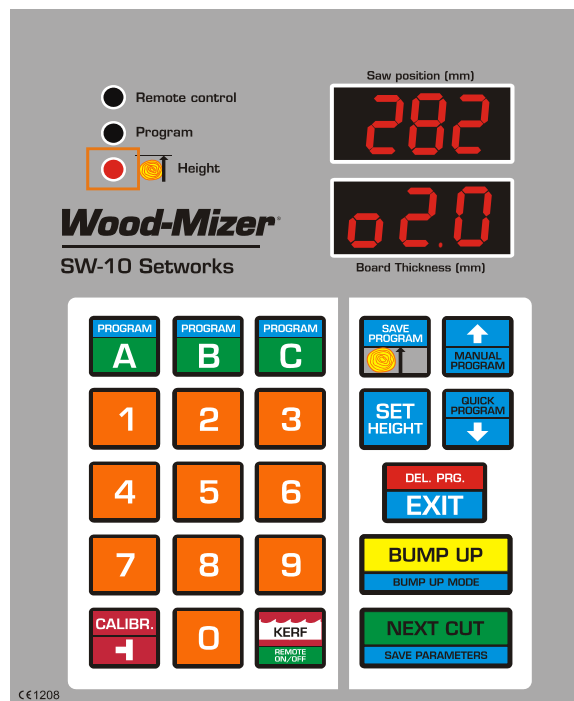





FIGURE 1-4

- Select the board thickness and press  .
- When the cut is made, press  ; the head will go up to the preprogrammed height above the log or cant.
- Press  and the saw head will drop by the selected board thickness to the next cut position.
- Press and hold  to exit the current mode of operation.

1 OPERATION

Remote Mode

1.5 Remote Mode

The SW-10 controller is adapted for use along with the sawmill up/down switch. Therefore, during cutting you can use the up/down switch instead of the **NEXT CUT** and **BUMP UP** buttons. The Remote mode is activated with the **KERF** button. After activating of this function, the “Remote control” light should come on.

The Remote mode is activated automatically after confirming a sawing program. You can at any time disable this mode to make changes in the program and then activate it again.

See Figure 1-5.

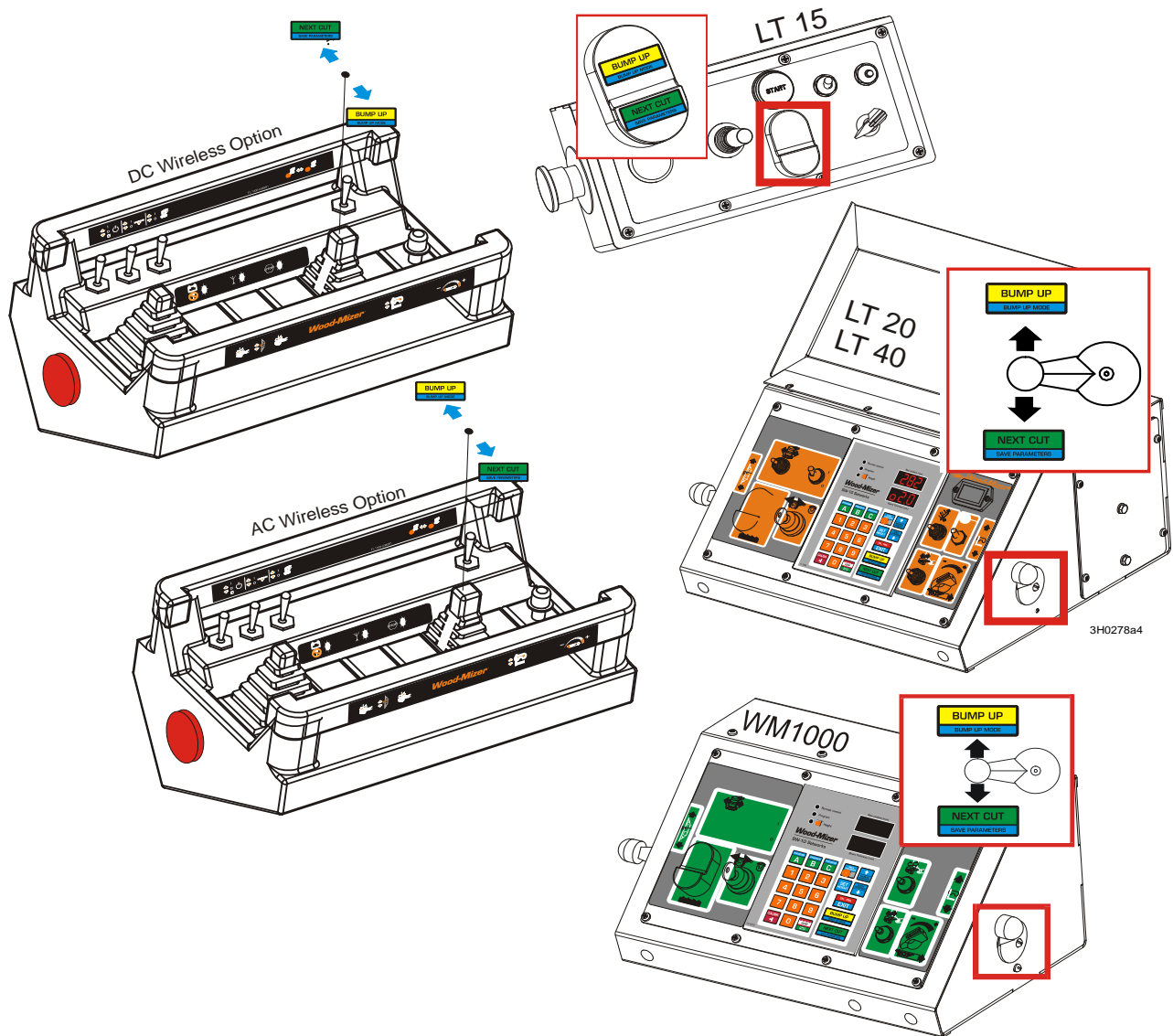

FIGURE 1-5



1.6 Pattern Modes

To create a series of cuts calculated from the bed level, use one of the Pattern modes: Manual Program or Quick Program.

These two modes can be used for entering a program for cutting one log only. Such programs are not saved in the controller memory and are deleted when the cutting operation is completed.

1.6.6 "Manual Program" Mode

Entering a Program in the "Manual Program" Mode

- Position the saw head at the height of the top end of the log.
- Push . The "Program" light will come on and "P- 1" will appear on the display.
- Using the keypad, enter the dimension of the first board calculated from the sawmill bed.
- Press  and enter the next board thickness. Repeat until the total of the entered board thicknesses, plus the kerf value calculated by the controller, exceeds the blade height value. It will be signaled by blinking of the value in the upper display window.

CAUTION! You can at any time raise the saw head manually, using the up/down switch, and add next board ticknesses to the program. The Remote mode has to be disabled.



- Push  to position the blade at the height of the first cut.

CAUTION! If you want to saw in the Manual Program mode without removing each cut board - once the blade is set at the height of the first cut - position the blade above the log or cant so that it clears the log/cant along its entire length.

- Complete entering of the program by pushing . If the head return height was preset, the "Height" light will come on indicating that this value was saved.

CAUTION! If "Pres cut" is displayed after pushing , the blade is not set

at the height of the first cut and you have to press  to perform this setting.





- Start the cutting process. When cutting, use the  and  buttons, as in the normal mode.

1.7.1 "Quick Program" Mode

The Quick Program mode can be used to quickly create a program of cuts referenced from the sawmill bed. In this mode, it is not necessary to enter each board thickness value, as opposed to the Manual Program mode. A value currently displayed in the "Board Thickness" window is automatically copied to all items in the program. If needed, the operator can change one or more board dimensions in the program.

The number of boards that can be cut is calculated from the bed rails, as in the Manual Program mode.



Entering a Program in the "Quick Program" Mode

- Position the head at the height of the top end of the log.
- Push . The "Program" light will come on and the display will show "StrPro" and then the number of the nearest possible cut. All programmed board thicknesses are of the dimension that was displayed before activating the Quick Program mode. If needed, you can change any of the board thickness values. To do that, scroll to the desired value with the  and  arrow buttons and enter a new value using the keypad.
- Using the arrows, select the program item from which the cutting process will be started. Press ; the saw head will position at the height corresponding to the selected item.

CAUTION! If you want to saw in the Quick Program mode without removing each cut board - once the blade is set at the height of the first cut - position the blade above the log or cant so that it clears the log/cant along its entire length.

- Complete entering of the program by pushing . If the head return height was preset, the "Height" light will come on indicating that this value was saved.

CAUTION! Remember to set the head at the first cut position before completing the program.



- Start the cutting operation. When cutting, use the  and  buttons, as in the normal mode.

1.8.1 Storing Programs in the Setworks Memory



The controller allows the operator to create and store three sawing programs. Thus, the operator can quickly activate a program with frequently used board dimensions, saving time needed for making changes in any existing program.

The sawing programs are marked **A**, **B** and **C**.

Entering and Storing a New Program

- Before entering a new program, delete the program previously stored. Push and hold down one of the program buttons (e.g. A). Then press and hold down . The display will show "Clr" for a while confirming that the program has been deleted and the normal mode will automatically be restored.
- Push and hold down the program button again. The program item number (1) will appear in the upper display window, and the lower display window will show horizontal dashes. Using the keypad, enter the thickness of the first board from the sawmill bed.
- Push  and enter the next board thickness. Repeat this step until all required board dimensions are entered. (You can enter up to 60 different dimensions.)
- Save the program by pressing . If any of the sixty programs were not used, the last entered board thickness will automatically be copied to these items.

Using Stored Programs

- Activate the previously stored program by pressing and holding down the appropriate program button (A, B or C).
- The display will show "StrPro" and then the number of the nearest possible cut. If needed, you can change any of the board thickness values in the program. To do that, scroll to the desired value with the  and  arrow buttons and enter a new value using the keypad. These changes, however, will not be stored in the controller memory.
- Using the arrows, select the program item from which the cutting process will be started. Press  and the saw head will position at the height corresponding to the selected item.

CAUTION! If you want to saw without removing each cut board - once the blade is set at the height of the first cut - position the blade above the log or cant so that it clears the log/cant along its entire length.







- Finish activating of the program by pressing . If the head return height was preset, the "Height" light will come on indicating that this value was saved.

CAUTION! Remember to set the head at the first cut height before you finish activating of the program.

- Start the cutting process. When cutting, use the  and  buttons, as in the normal mode.

Example:

In this example we have a log with three sides flat and we want to finish with a 100mm x 100mm cant and get three boards - 50mm, 28mm and 25mm. "Through and through" cutting procedure (without removing a board after each cut) will be described.

- Position the head a little above the log.
- To enter the programming mode, press and **hold** . The "Program" light will come on and "P- 1" will appear on the display.
- Using the keypad, enter the first board thickness value (100) and press . Enter the next board thicknesses (50, 28 and 25mm); each time confirm the setting by pressing .
- Press  and the head will move to the first cut height.
- Raise the head so that it clears the log along its entire length.
- Press . The "Height" light will come on, indicating that the head return height has been stored.
- Cut the material using  and , as in the normal mode of operation. ([See Section 1.3.](#))
- After cutting the last board, **"End pro"** will be shown on the display to indicate the end of cutting.

- Remove the boards.

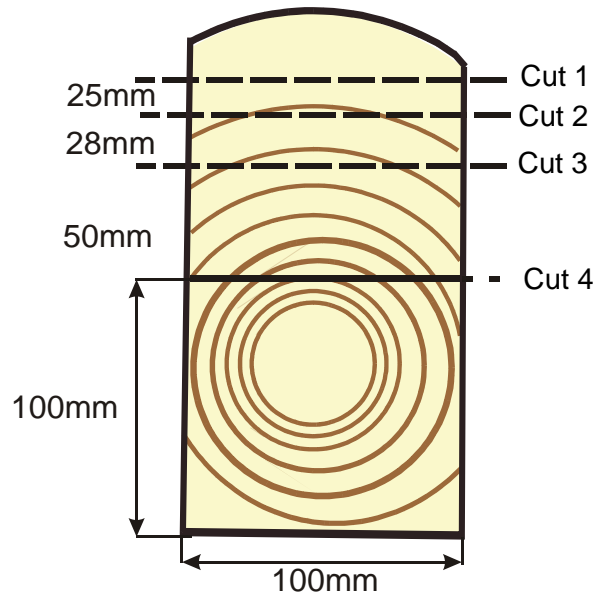



FIGURE 1-2

SECTION 2 TROUBLESHOOTING

2.1 Networks Malfunction

PROBLEM	CAUSE	SOLUTION
<p>Setworks does not work.</p> <p>When performing a program, the controller disengages the drive mechanism and the display shows:</p>  <p>The top display is labeled 'Saw position (mm)' and shows '000'. The bottom display is labeled 'Board Thickness (mm)' and shows 'ErP'.</p>	<p>Magnet sensor improperly adjusted</p>	<p>Align the magnet sensor as shown in figures 2-1 and 2-2. Calibrate the controller. See Section Auto-calibration.</p> <p>Check condition of the encoder coupling that connects the encoder with the up/down screw (LT15 sawmills only)</p>
<p>When performing the auto-calibration, the controller disengages the drive mechanism and the display shows:</p>  <p>The top display is labeled 'Saw position (mm)' and shows 'Auto'. The bottom display is labeled 'Board Thickness (mm)' and shows 'ErP'.</p>	<p>Improper input parameters</p>	<p>Check the input divider and the kerf settings (See Section Setting the Input Divider (entered only once, at the first start-up) and See Section Entering the Blade Kerf Thickness).</p> <p>- Perform the auto-calibration procedure. See Section Auto-calibration.</p>
<p>Setworks calculates dimensions of boards incorrectly.</p>	<p>Controller not calibrated</p>	<p>Check the input divider and the kerf settings. Perform the auto-calibration procedure.</p>
<p>Saw head does not stop at the required blade height, but continues its upward or downward movement until it hits the stop bolt or the upper limit switch is activated.</p>	<p>Controller not calibrated</p>	<p>Check the input divider and the kerf settings. Perform the auto-calibration procedure.</p>

Setworks stops the saw head and "Err PULS" appears on the display.



Blade height sensor signal is bad.

- Check the connections between the blade height sensor and the controller.
- Check if the encoder or the magnetic strip (depending on the machine) is not loose.
- Check condition of the encoder coupling (LT15 sawmills only).
- Check if the connections to the sawmill up/down system contactors are correct and not loose.

During manual downward head movement, the upper display shows a negative blade height value.

Setworks not calibrated

Perform the auto-calibration procedure.

When pressing  **during normal operation or when attempting to save the program (using**  **button), the upper display shows horizontal dashes.**

The lower blade height limit would be exceeded if the requested saw head movement was performed.

Try to enter a lower board thickness value.

During manual controlling of the head height, the display shows:



Real blade height incorrectly entered

Enter the real distance between the blade and the bed rails. [See Section Entering Real Blade Height Dimensions.](#)
 Perform the auto-calibration procedure.

2

Troubleshooting *Setworks Malfunction*

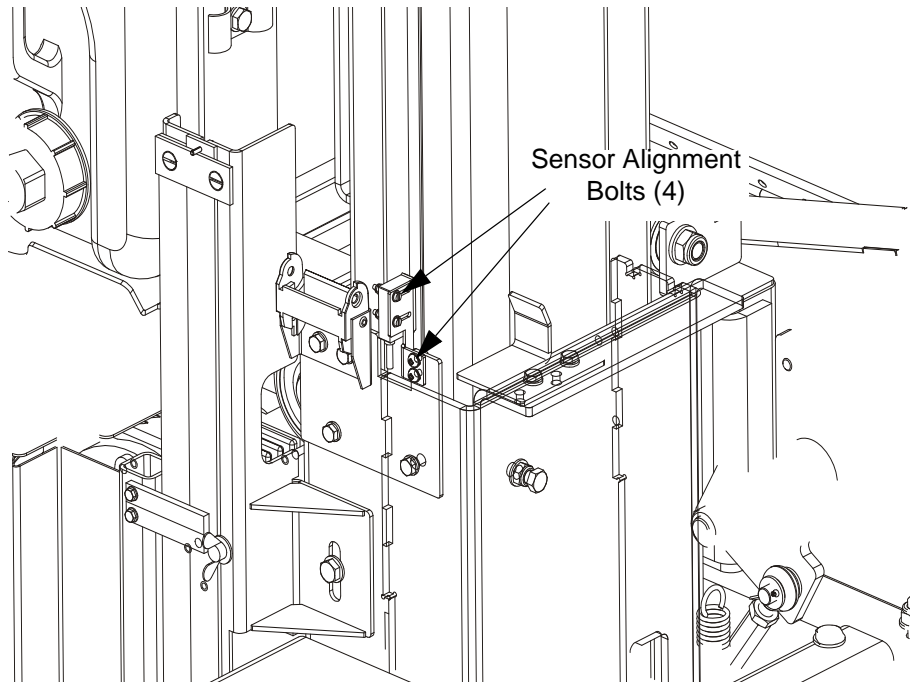

FIG. 2-1

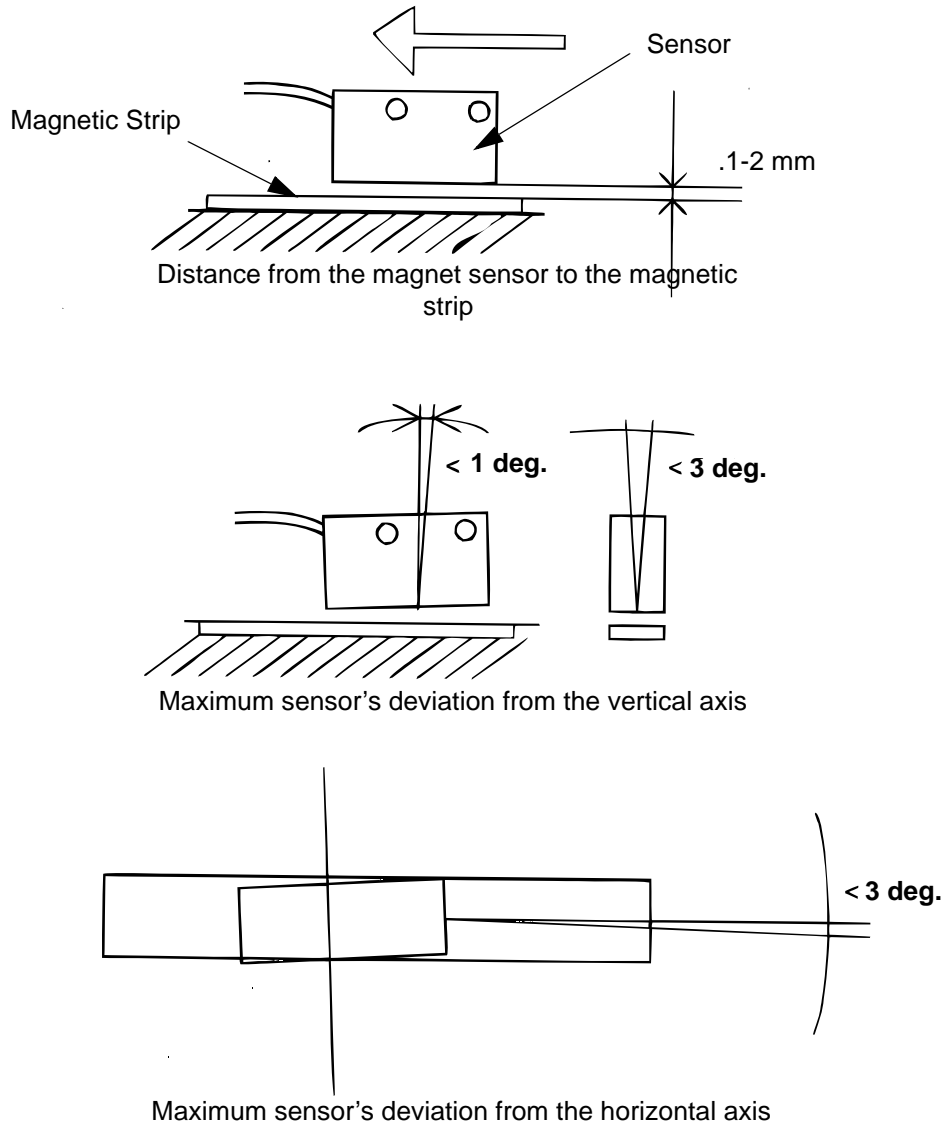

FIG. 2-2

SECTION 3 REPLACEMENT PARTS

3.1 How To Use The Parts List

- Use the table of contents or index to locate the assembly that contains the part you need.
- Go to the appropriate section and locate the part in the illustration.
- Use the number pointing to the part to locate the correct part number and description in the table.
- Parts shown indented under another part are included with that part.
- Parts marked with a diamond (◆) are only available in the assembly listed above the part.

See the sample table below. Sample Part #A01111 includes part F02222-2 and subassembly A03333. Subassembly A03333 includes part S04444-4 and subassembly K05555. The diamond (◆) indicates that S04444-4 is not available except in subassembly A03333. Subassembly K05555 includes parts M06666 and F07777-77. The diamond (◆) indicates M06666 is not available except in subassembly K05555.

3.2 Sample Assembly				
REF	DESCRIPTION (◆ Indicates Parts Available In Assemblies Only)	PART #	QTY.	
	SAMPLE ASSEMBLY, COMPLETE (INCLUDES ALL INDENTED PARTS BELOW)	A01111	1	
1	Sample Part	F02222-22	1	
	Sample Subassembly (Includes All Indented Parts Below)	A03333	1	
2	Sample Part (◆ Indicates Part Is Only Available With A03333)	S04444-4	1	◆
	Sample Subassembly (Includes All Indented Parts Below)	K05555	1	
3	Sample Part (◆ Indicates Part Is Only Available With K05555)	M06666	2	◆
4	Sample Part	F07777-77	1	

To Order Parts:

- From Europe call our European Headquarters and Manufacturing Facility in Kolo, Poland at **+48-63-2610233**. From the continental U.S., call our toll-free Parts hotline at **1-800-448-7881**. Have your customer number, vehicle identification number, and part numbers ready when you call.
- From other international locations, contact the Wood-Mizer distributor in your area for parts.

3.3 SW-10 Networks for LT20 Series Sawmills

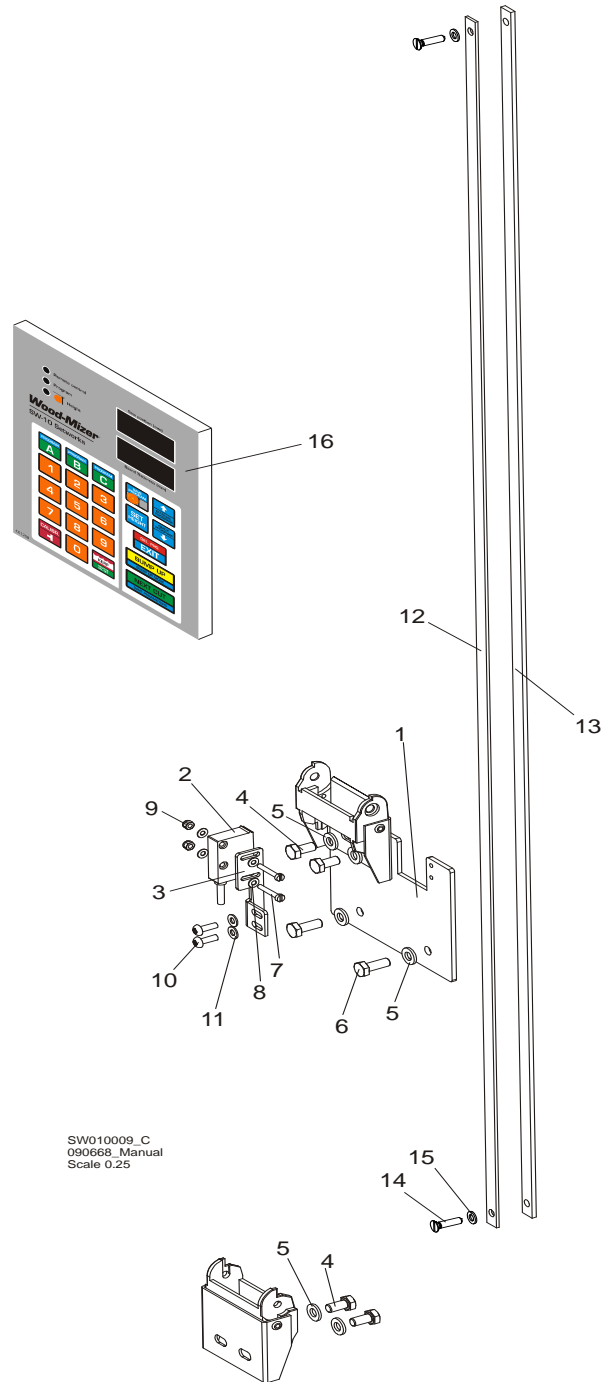

REF.	DESCRIPTION (◆ Indicates Parts Available In Assemblies Only)	PART #	QTY.
	CABLE CARRIER & SENSOR ASSEMBLY	098052	1
1	Plate, Cable Carrier & Sensor Mounting	096067-1	1
2	Sensor, MSK-320	096014	1
3	Bracket, MSK-320 Sensor Mount	096068-1	1
4	Bolt, M6x12-8.8 Hex Head Full Thread Zinc	F81001-7	4
5	Washer, 6.4 Flat Zinc	F81053-1	6

6	Bolt, M6x16-5.8 Hex Head Full Thread Zinc	F81001-14	2	
7	Screw, M3x20-5.8-A Slotted Cheese Head Zinc	F81000-8	2	
8	Washer, 3.2 Flat Zinc	F81050-2	4	
9	Nut, M3-6 Hex Nylon Zinc Lock	F81028-2	2	
10	Screw, M4x12-5.8-B Cross Recessed Pan Head Zinc	F81011-43	2	
11	Washer, 4.3 Flat Zinc	F81051-2	2	
	Carrier, SR300A 050 080 Cable	097924	1	
	MAGNETIC STRIP ASSEMBLY	097774	1	
	Bar w/Magnetic Strip	098173-1	1	
12	Strip, MB320 Magnetic (1m)	096014-1	1	
13	Bar, Magnetic Strip	098173	1	
14	Screw, M5x20-5.8-B Zinc-plated	F81000-34	2	
15	Washer, 5.3 Flat Zinc	F81052-1	2	
	MEMBRANE, SW10 CONTROLLER	083730	1	
16	CONTROLLER, SW-10	500628	1	
	REAR CONTROLLER FRAME	100909	1	

3.4 SW-10 Networks for LT40 Series Sawmills

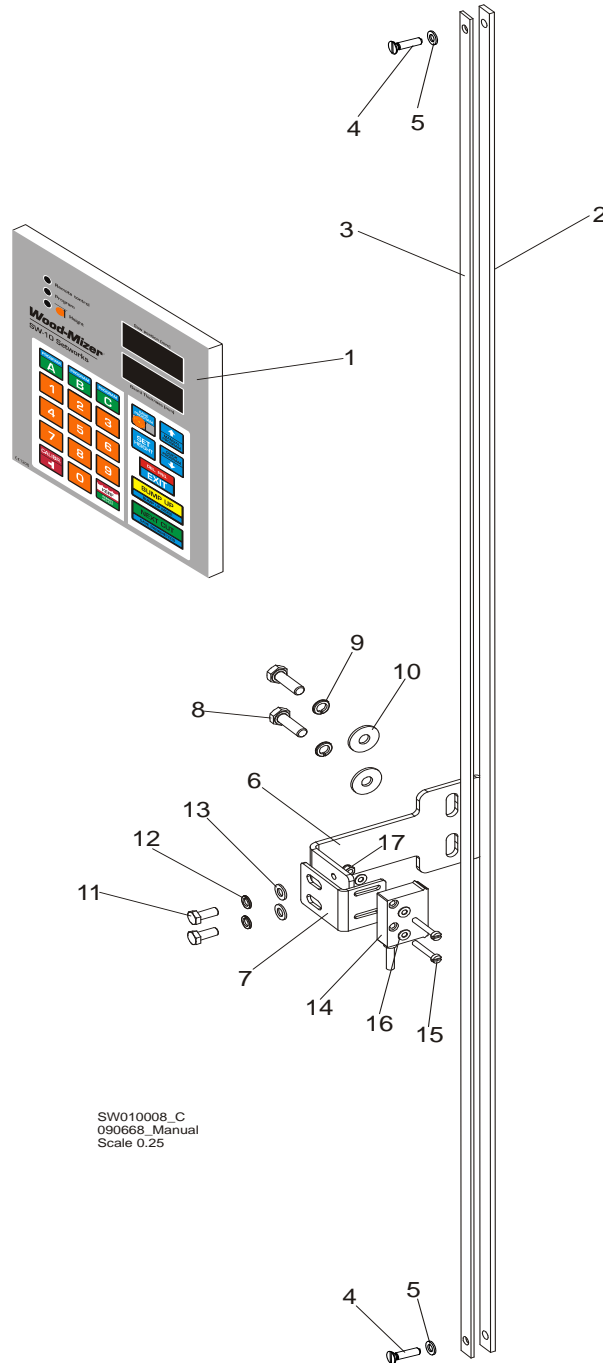

SW010008_C
090668_Manual
Scale 0.25

REF.	DESCRIPTION (◆ Indicates Parts Available In Assemblies Only)	PART #	QTY.
1	CONTROLLER, SW-10	500628	1
	FRAME, CONTROLLER REAR	100909	1
	MEMBRANE, SW10 CONTROLLER	083730	1
	MAGNETIC STRIP ASSEMBLY	097774	1
	Bar w/Magnetic Strip	098173-1	1
2	Bar, Magnetic Strip	098173	1
3	Strip, MB320 Magnetic (1m)	096014-1	1

4	Screw, M5x20-5.8-B Zinc-plated	F81000-34	2	
5	Washer, 5.3 Flat Zinc	F81052-1	2	
	SENSOR MOUNT BRACKET - COMPLETE	100620	1	
6	Bracket, Sensor Mount	100599-1	1	
7	Bracket, Sensor Mount	100619-1	1	
8	Bolt, M6x20-8.8 Hex Head Full Thread Zinc	F81001-2	2	
9	Washer, Z 6.1 Split Lock Zinc	F81053-3	2	
10	Washer, 6.5 Special Flat Zinc	F81053-11	2	
11	Bolt, M5x12-5.8 Hex Head Full Thread Zinc	F81000-5	2	
12	Washer, 5.1 Split Lock Zinc	F81052-2	2	
13	Washer, 5.3 Flat Zinc	F81052-1	2	
14	SENSOR, MSK-320	096014	1	
15	SCREW, M3X20-5.8-A SLOTTED CHEESE HEAD ZINC	F81000-8	2	
16	WASHER, 3.2 FLAT ZINC	F81050-2	4	
17	NUT, M3-6 HEX NYLON ZINC LOCK	F81028-2	2	

3.5 SW-10 Networks for WM1000 Sawmills

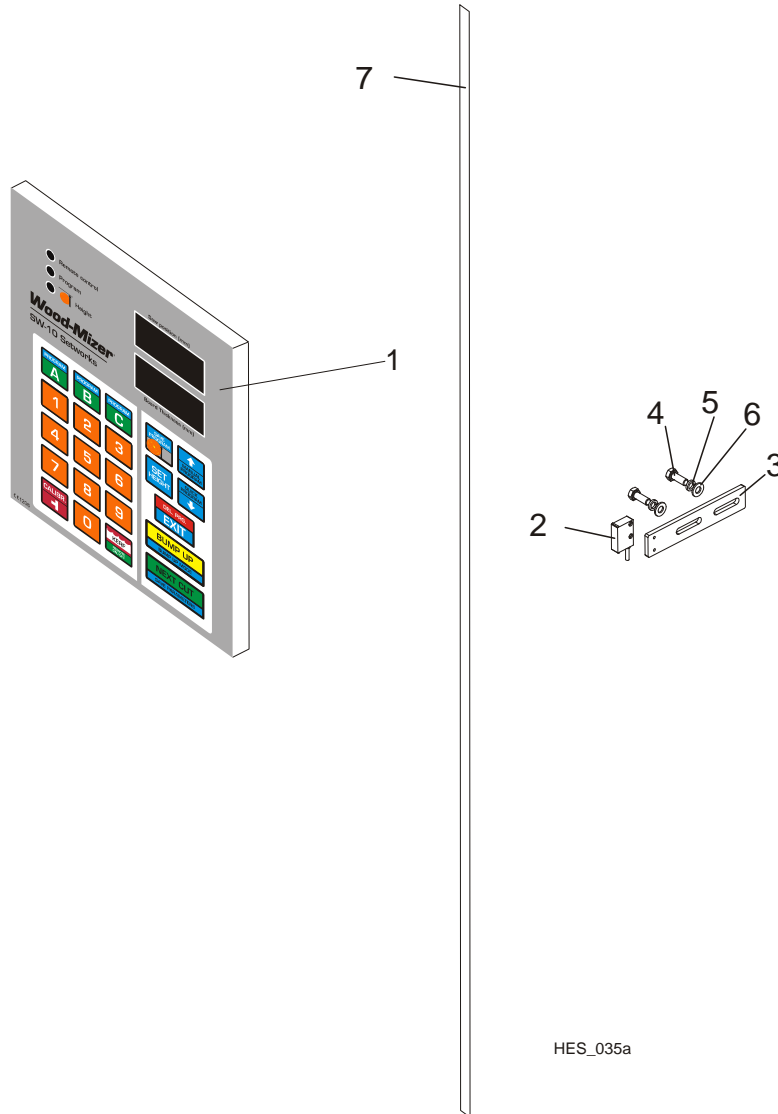

HES_035a

REF.	DESCRIPTION (◆ Indicates Parts Available In Assemblies Only)	PART #	QTY.
1	CONTROLLER, SW-10	500628	1
2	SENSOR, MSK-320	096014	1
3	BAR, WM1000 SENSOR MOUNTING ZINC-PLATED	504661-1	1
4	BOLT, M8X20-8.8-B HEX HEAD FULL THREAD ZINC	F81002-4	2
5	WASHER 8,2 SPLIT LOCK ZINC	F81054-4	2
6	WASHER, 8.4 FLAT ZINC	F81054-1	2
7	TAPE, MB320 MAGNETIC (1M)	096014-1000	1