

Wood-Mizer®

Parts Manual

LT70 B1-4 E15S MH	rev. A2.02
LT70 B1-4 E20S MH	rev. A2.02
LT70 B1-4 E25S MH	rev. A2.02



Safety is our #1 concern! Read and understand all safety information and instructions before operating, setting up or maintaining this machine.

January 2011

Form #638

Table of Contents

Section-Page

General Contact Information

Branches & Authorized Sales Centers Wood-Mizer Locations (North and South America)

SECTION 1	GENERAL INFORMATION	1-1
1.1	How To Use The Parts List	1-1
1.2	Sample Assembly	1-1
SECTION 2	BLADE GUIDE ROLLERS & ARM	2-1
2.1	Blade Guide Assembly, Idle Side	2-1
2.2	Blade Guide Assembly, Drive Side	2-2
2.3	Blade Guide Arm Drive Assembly.....	2-4
2.4	Blade Guide Mount Assembly, Drive Side	2-6
SECTION 3	BLADE WHEELS & TENSIONER	3-1
3.1	Blade Drive Assembly.....	3-1
3.2	Idle Blade Wheel Assembly	3-2
3.3	Hydraulic Blade Tensioner Assembly.....	3-4
3.4	Sawdust Flow Guide.....	3-6
SECTION 4	SAW HEAD	4-1
4.1	Middle Throat Screw	4-1
4.2	Drive Belt Tensioner LT70 AC.....	4-1
4.3	Board Return Assembly (Optional)	4-2
4.4	Water Lube Assembly	4-4
4.5	LT70AC Saw Head Decals	4-5
4.6	Blade Housing Covers.....	4-7
4.7	Sawdust Chute.....	4-8
4.8	Saw Head Protection Kit, LT70L Mobile	4-9
SECTION 5	CONTROL & BATTERY BOXES	5-1
5.1	Control Assembly, LT40AC Series	5-1
5.2	Control Assembly, LT70 AH	5-3
5.3	Control Box Bracket.....	5-5
5.4	Drum Switches	5-6
5.5	Circuit Breakers.....	5-7

Table of Contents

Section-Page

SECTION 6 UP/DOWN SYSTEM

6-1

6.1	Up/Down Rollers & Covers	6-1
6.2	Blade Height Scale	6-2
6.3	Up/Down Chain & Sprockets	6-3
6.4	Up/Down Drive Assembly	6-4
6.5	Safety Switches	6-6

SECTION 7 FEED SYSTEM & TRACK ROLLERS

7-1

7.1	Upper Track Rollers And Wipers.....	7-1
7.2	Power Feed Assembly	7-3
7.3	Feed Chain/Stop	7-5
7.4	Lower Track Rollers.....	7-6

SECTION 8 BED FRAME ASSEMBLY

8-1

8.1	Bed Section.....	8-1
8.2	Bed Section, Additional	8-2
8.3	Bed Extension.....	8-3
8.4	Stationary Leg Kit	8-4
8.5	Outrigger Leg Kit	8-5
8.6	Outrigger Leg Kit High - LES B3	8-6
8.7	Log Side Support Assembly	8-7
8.8	Front & Rear Tubes	8-8
8.9	Bumpers.....	8-9
8.10	Remote Equipment Option	8-10
8.11	Bed Frame Decals.....	8-11
8.12	Saw Head Transportation Holder, LT70B.....	8-12

SECTION 9 LOG CLAMP, LOADING RAMP & TOE BOARD

9-1

9.1	Log Clamp, LES	9-1
9.2	Loading Ramp	9-2
9.3	Manual Toe Board.....	9-3
9.4	H1/H2/H3 Control Assemblies - Options.....	9-4
9.5	Toe Board Roller Option	9-7
9.6	Roller Turner Option	9-9
9.7	Winch Option	9-11
9.8	Log Side Supports w/Lever Option.....	9-12

Getting Service

Wood-Mizer is committed to providing you with the latest technology, best quality and strongest customer service available on the market today. We continually evaluate our customers' needs to ensure we're meeting current wood-processing demands. Your comments and suggestions are welcome.

General Contact Information

From Europe call your local distributor or our European Headquarters and Manufacturing Facility in Koło, Nagórna 114 St, Poland at **+48-63-2626000**. From the continental U.S., call our U.S. Headquarter 8180 West 10th St. Indianapolis, IN 46214, toll-free at **1-800-525-8100**. Ask to speak with a Customer Service Representative. Please have your machine identification number and your customer number ready when you call. The Service Representative can help you with questions about the operation and maintenance of your machine. He also can schedule you for a service call.

Office Hours:

Country	Monday - Friday	Saturday	Sunday
Poland	7 a.m.- 3 p.m.	Closed	Closed
US	8 a.m.- 5 p.m.	8 a.m.- 12 p.m	Closed

Please have your vehicle identification number and your customer number ready when you call.



Wood-Mizer will accept these methods of payment:

- Visa, Mastercard, or Discover
- COD
- Prepayment
- Net 15 (with approved credit)

Be aware that shipping and handling charges may apply. Handling charges are based on size and quantity of order.

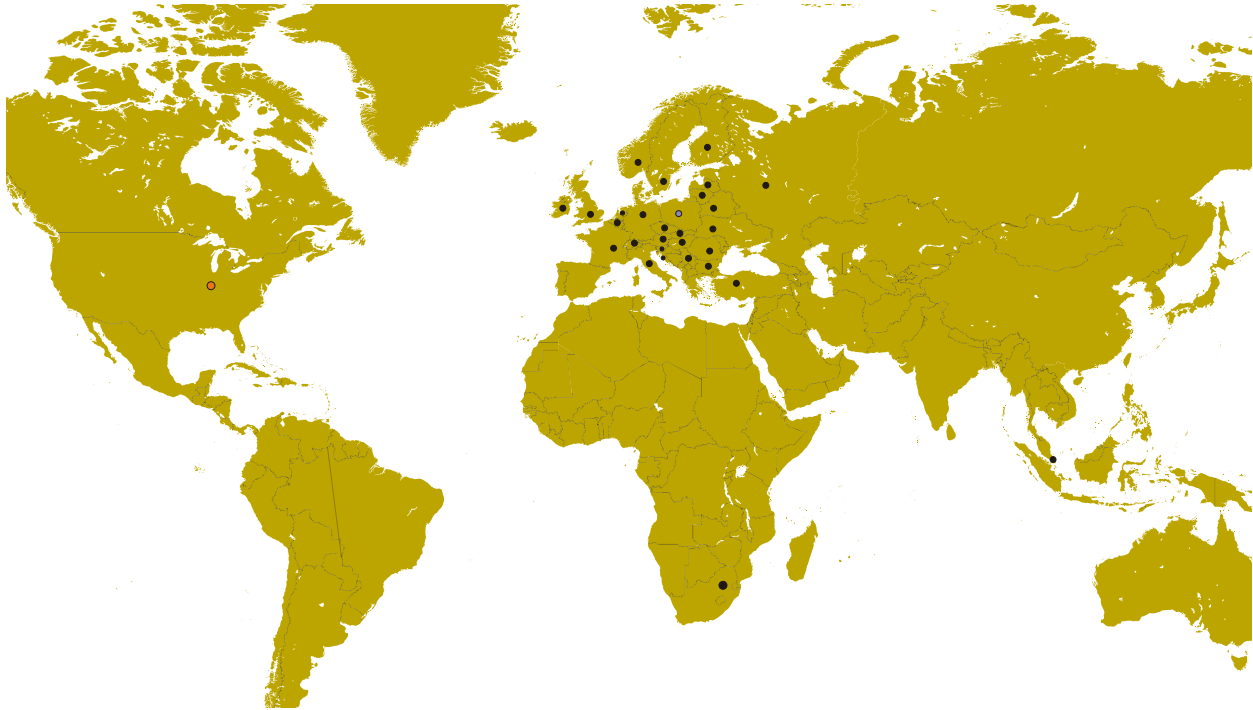
Branches & Authorized Sales Centers Wood-Mizer Locations (North and South America)



EUROPE		UNITED STATES
<p> European Headquarters Wood-Mizer Industries Sp. z o.o. Nagórna 114, 62-600 Kolo, Poland Tel.: +48-63-26-26-000 Fax: +48-63-27-22-327 www.woodmizer.eu</p>		<p> World Headquarters Wood-Mizer LLC 8180 West 10th Street Indianapolis, Indiana 46214-2400, USA Tel.: +1-317-271-1542 Fax: +1-317-273-1011 www.woodmizer.com</p>
<p>BELARUS MOST-GRUPP Siemashko 15, k.3 Minsk 2200116 Tel.: +375-17-270-90-08 Fax: +375-17-270-90-08 GSM: +375-29-649-90-80 e-mail: most-by@mail.ru</p>	<p>SWITZERLAND Bruno Steiner Striegelgasse 2 CH-6214 Schenkon Tel.: +41-41-921-13-01 Fax: +41-41-922-18-87 e-mail: info@mobilsaegen.ch</p>	<p>RUSSIA Dariusz Mikołajewski OOO WOOD-MIZER INDUSTRIES 141031, Moscow Reg., Mytishenski raj., pos. Veshki, Zavodskaja str., 3B Tel.Fax: +7(495) 788-72-35 Tel.Fax: +7(495) 641-51-60 e-mail: dariuszm@woodmizer-moscow.ru</p>
<p>BULGARIA Kalin Simeonov Ecotechproduct 38 Star Lozenski pat str. Sofia 1186 Tel.: +359-2-462-7035 Tel.: +359-2-963-1656 Tel./Fax : +359-2-979-1710 Kalin Simeonov GSM: +3592-963-2559 e-mail: office@ecotechproduct.com</p>	<p>HUNGARY Wiktor Turoczy Wood-Mizer Hungary K.F.T. Szonyi Ut 67., 2921 Komárom Tel./Fax: +36-34-346-255 e-mail: woodmizer@woodmizer.hu</p>	<p>RUSSIA Far East Wladimir Glazaczew "WM Service" Krasnoretschenskaya Str.111 680006 Khabarovsk Tel./Fax: +7-914-541-1183 e-mail: wms-khv@mail.ru</p>

<p>CROATIA Krešimir Pregernik Pregimex d.o.o. S. Batušića 31, 10090 Zagreb Tel./Fax: +3851-38-94-668 Krešimir Pregernik GSM: +3851-98-207-106 e-mail: Kresimir.Pregernik@gmail.com</p>	<p>ITALY Pasquale Felice Wood-Mizer Italia Srl Cda. Capoiaccio SN 86012 Cercemaggiore Campobasso Tel./Fax: +39-0874-798-357 GSM: +39-333-281-03-79 e-mail: wmitaliasrl@gmail.com</p>	<p>SERBIA Dragan Markov Wood-Mizer Balkan d.o.o. Svetosavska GA 3/3; P. Fah 25 23 300 Kikinda Tel./Fax: +381-230-25-754 Tel./Fax: +381-230-23-567 GSM: +381-63-568-658 e-mail: office@woodmizer.co.yu</p>
<p>CZECH REPUBLIC Miroslav Greill Wood-Mizer CZ s.r.o. Osvaldova 91 339 01 Klatovy-Luby Tel./Fax: +420-376-312-220 Fax: +420-376-319-011 Miroslav Greill GSM: +420-723-580-799 e-mail: greill@woodmizer.cz</p>		<p>SLOVAKIA Wiktor Turoczy Wood-Mizer Danubia s.r.o. Hadovce 5, 94501 Komárno Tel.: +421-35-77-40-316 Fax: +421-35-7740-326 GSM: +421-905-930-972 e-mail: woodmizer@woodmizer.sk</p>
<p>CZECH REPUBLIC Lubomir Kudlik Wood-Mizer Moravia Sovadinova 6 69002 Breclav Tel./Fax: +420-519-322-443 Lubomir Kudlik GSM: +420-602-734-792 e-mail: info@wood-mizer.net</p>	<p>LATVIA Vilmars Jansons OBERTS Ltd Gaujas str. 32/2 LV-2167 Marupe, Rigas Raj. Tel.: +371-7-810-666 Fax: +371-7-810-655 Vilmars Jansons GSM: +371-92-06-966 Andris Orols GSM: +371-28-33-07-90 e-mail: andris@oberts.lv</p>	<p>TURKEY Er-Ka Ahsap Profil Kerestecilik San. ve Tic. Ltd. Sti. Adana Keresteciler Sitesi 191 sk No.41 ADANA Tel.: +90-322-346-15-86 Fax: +90-322-345-17-07 GSM: +90-533-363-18-44 e-mail: info@erkaahsap.com.tr</p>
<p>FINLAND Howard Blackbourn Oy Falkberg Jordbruk Ab Falkintie 220 25610 Ylonkyla Tel.: +358-2732-2253 Fax: +358-2732-2263 Howard Blackbourn GSM: +358-440-424-339 e-mail: falkberg@woodmizer.fi</p>	<p>LITHUANIA Andrius Zuzevicius UAB Singlis Savanoriu pr. 187, 2053 Vilnius Tel.: +370-5-2-32-22-44 Fax: +370-5-2-64-84-15 GSM: +370-620-28-645 e-mail: andrius.z@singlis.lt</p> <p>Dmitrij Gaiduk GSM: +370-69-84-51-91 e-mail: dmitrijus.g@singlis.lt</p>	<p>UKRAINE Ivan Vinnicki MOST UKRAINA bul. Myru 3, Bajkivtsi Ternoplskyj r-j Ternopolska oblast 47711 Ukraine Tel/Fax: +38 (0352) 52 37 74 GSM: +38 (067) 352 54 34 GSM: +38 (067) 674 50 68 E-mail: most-ukraina@ukr.net</p>
<p>FRANCE Tizoc Chavez Wood-Mizer France 556 chemin des Embouffus, ZAC des Basses Echarrieres 38440 SAINT JEAN DE BOURNAY Tel: +33-4 74 84 84 44 GSM: +33-607 52 02 82 Mail: tchavez@woodmizer.fr</p>	<p>NORWAY Odd Edvoll Wood-Mizer Nordic AS Vardelia 17, 2020 Skedsmokorset Tel.: +47-63-87-49-89 Fax: +47-63-87-37-66 GSM: +47-930-42-335 e-mail: odd.edvoll@woodmizer.no</p> <p>e-mail: firmapost@woodmizer.no</p>	<p>UNITED KINGDOM & IRELAND Wood-Mizer UK Hopfield Barn Kenward Road, Yalding Kent ME18 6JP, UK Tel.: +44-1622-813-201 Fax: +44-1622-815-534 e-mail: info@woodmizer.co.uk</p>
<p>SLOVENIA Jan Fale FAMTEH d.o.o. Gacnikova pot 2, 2390 Ravne na Koroskem Tel.: +386-2-62-04-232 Fax: +386-2-62-04-231 Jan Fale GSM: +386-2-62-04-230 e-mail: jan.fale@famteh.si</p> <p>Matjaz Kolar Tel.: +386-2-62-04-232 GSM: +386-31-775-999 e-mail: matjaz.kolar@famteh.si</p>		

<p>GERMANY Klaus Longmuss Wood-Mizer Sägewerke GmbH Dorfstraße 5, 29485 Schletau Tel.: +49-5883-9880-10 Fax: +49-5883-9880-20 e-mail: info@woodmizer.de</p> <p>Klaus Longmuss Tel.: +49-5883-9880-12 GSM: +49-17-298-55-892 e-mail: KLongmuss@woodmizer.de</p>	<p>Subagent: SWEDEN Kjell Larsson Mekwood AB Slingan 14, 812 41 Gästrike-Hammarby Tel.: +46-290-515-65 Kjell Larsson GSM: +46-706-797-965 e-mail: kjell.larsson@mekwood.se</p>	<p>IRELAND Wood-Mizer Ireland Stephen Brennan Cum Lahardane Ballina County Mayo Tel:+353 96 51345</p> <p>E-mail: brennanmill@ericom.net</p>
<p>Subagents: DENMARK Brian Jensen Arnborgvej 9, 7330 Brande- Fasterholt Tel.: +45-971-88-265 Fax: +45-971-88-266</p> <p>Brian Jensen GSM: +45-23-49-5828 e-mail: Fasterholt-Savvaerk@Mail.Tele.dk</p>	<p>ROMANIA Adrian Echert SC WOOD-MIZER RO SRL TRANSILVANIEI Nr. 5 Sibiu, Cisnadio 555300 Tel./Fax: : +40-369-405-433 GSM: +40-745-707-323 e-mail: aechert@woodmizer.ro</p>	<p>Regional Manager - Asia Wood-Mizer Asia Pte Ltd. James Wong Tel: +65 81216910 Fax: +65 6283 8636 WWW: www.woodmizerasia.com E-mail: jwong@woodmizerasia.com</p>
<p>Netherlands Chris Dragt Lange Brink 77d, 7317 BD Apeldoorn Tel.: +31-55312-1833 Fax: +31-55312-2042 e-mail: Info@dragtbosbouw.nl</p>	<p>Subagent: ROMANIA M. Echert S.C. Echert Comprod s.r.l Str. Schitului Nr. 6, Apt.7 etajul-1 725 70 Vatra Dornei, Romania Tel./Fax: +40-230-374-235 Tel. : +40-740-35-35-74</p>	<p>Regional Manager - Africa Wood-Mizer Africa Jean-Jacques Oelofse UNIT 3, LEADER PARK, NO: 20 CHARIOT ROAD STORMILL, EXT 5, Roodepoort, Johannesburg Tel: +27 011 473 1313 Fax: +27 011 473 2005 Jean-Jacques Oelofse E-mail: jjoelofse@woodmizer africa.com Jean-Jacques Oelofse Skype:jean.jacques.pierre.oelofse</p>

USA World Headquarters

Serving North & South America, Oceania, East Asia

Wood-Mizer LLC
8180 West 10th Street
Indianapolis, IN 46214

Phone: 317.271.1542 or 800.553.0182
Customer Service: 800.525.8100
Fax: 317.273.1011
Email: infocenter@woodmizer.com

Canadian Headquarters

Serving Canada

Wood-Mizer Canada
396 County Road 36, Unit B
Lindsay, ON K9V 4R3

Phone: 705.878.5255 or 877.357.3373
Fax: 705.878.5355
Email: ContactCanada@woodmizer.com

Brazil Headquarters

Serving Brazil

Wood-Mizer do Brasil
Rua Dom Pedro 1, No: 205 Bairro: Sao Jose
Ivoti/RS CEP:93.900-000

Tel: +55 51 9894-6461/ +55 21 8030-3338/ +55 51
3563-4784
Email: info@woodmizer.com.br

Europe Headquarters

Serving Europe, Africa, West Asia

Wood-Mizer Industries Sp z o.o.
Nagorna 114
62-600 Kolo, Poland

Phone: +48.63.26.26.000
Fax: +48.63.27.22.327

Branches & Authorized Sales Centers

For a complete list of dealers, visit www.woodmizer.com

SECTION 1 GENERAL INFORMATION

1.1 How To Use The Parts List

- Use the index above to locate the assembly that contains the part you need.
- Go to the appropriate section and locate the part in the illustration.
- Use the number pointing to the part to locate the correct part number and description in the table.
- Parts shown indented under another part are included with that part.
- Parts marked with a diamond (◆) are only available in the assembly listed above the part.

See the sample table below. Sample Part #A01111 includes part F02222-2 and subassembly A03333. Subassembly A03333 includes part S04444-4 and subassembly K05555. The diamond (◆) indicates that S04444-4 is not available except in subassembly A03333. Subassembly K05555 includes parts M06666 and F07777-77. The diamond (◆) indicates M06666 is not available except in subassembly K05555.

1.2 Sample Assembly				
REF	DESCRIPTION (◆ Indicates Parts Available In Assemblies Only)	PART #	QTY.	
	Sample Assembly, Complete (Includes All Indented Parts Below)	A01111	1	
1	Sample Part	F02222-22	1	
	Sample Subassembly (Includes All Indented Parts Below)	A03333	1	
2	Sample Part (◆ Indicates Part Is Only Available With A03333)	S04444-4	1	◆
	Sample Subassembly (Includes All Indented Parts Below)	K05555	1	
3	Sample Part (◆ Indicates Part Is Only Available With K05555)	M06666	2	◆
4	Sample Part	F07777-77	1	

To Order Parts:

- From Europe call our European Headquarters and Manufacturing Facility in Kolo, Poland at **+48-63-2626000**. From the continental U.S., call our toll-free Parts hotline at **1-800-525-8100**. Have your customer number, vehicle identification number, and part numbers ready when you call. From other international locations, contact the Wood-Mizer distributor in your area for parts.

Office Hours:

Country	Monday - Friday	Saturday	Sunday
Poland	7-15	Closed	Closed
US	8 a.m.- 5 a.m.	8 a.m.- 12 p.m.	Closed



CAUTION! It is strongly recommended that only original spare parts be used.

SECTION 2 BLADE GUIDE ROLLERS & ARM

2.1 Blade Guide Assembly, Idle Side

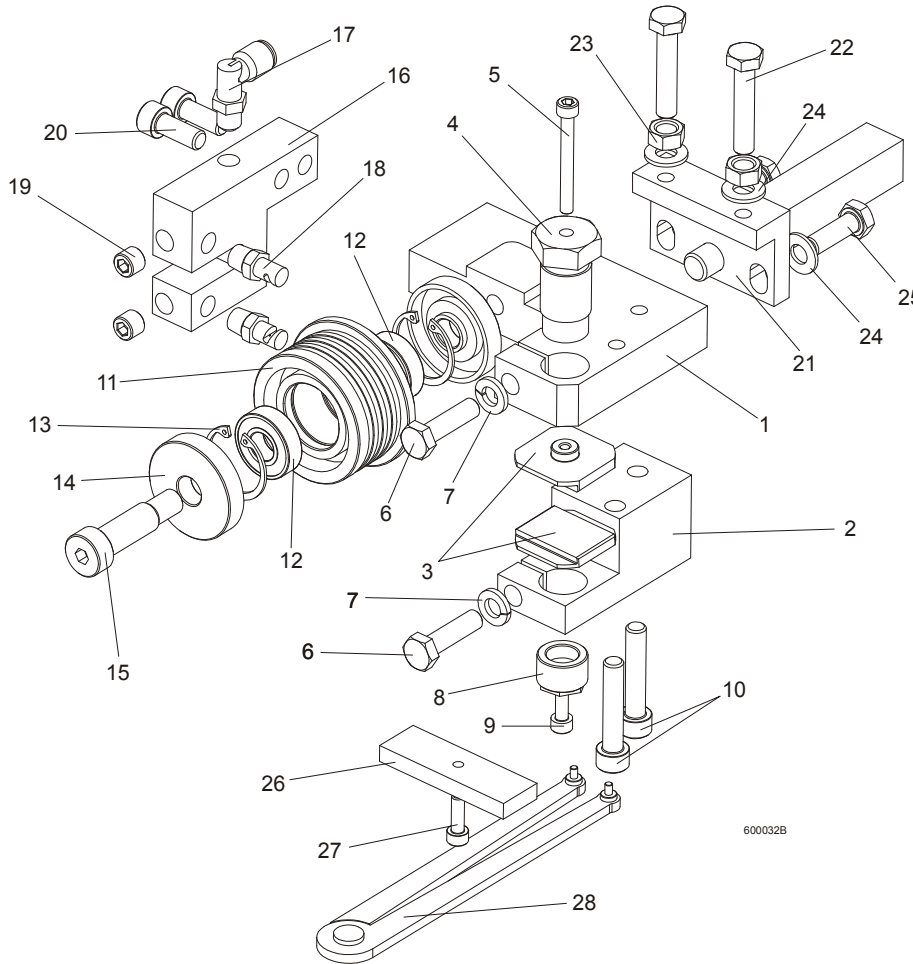

600032B

REF.	DESCRIPTION (◆ Indicates Parts Available In Assemblies Only)	PART#	QTY.
	BLADE GUIDE ASSEMBLY, IDLE SIDE, EXTENDED (for optional use with 1 1/2" blades)	092997	1
1	Block, Blade Guide Mount Zinc-plated	090947-1	1
2	Block, Lower Ceramic Pad Mount Zinc-plated	090948-1	1
3	Block, Blade Guide Zinc	093430-1	2
4	Bolt, Upper Pad Adjustment Zinc-plated	089515-1	1
5	Screw, M5x45 DIN912 A2-70 Hex Socket Head Cap Stainless Steel	F81000-24	1
6	Bolt, M8x30 DIN933 A2-70 Stainless Steel	F81002-27	2
7	Washer, 8.2 Split Lock Zinc	F81054-4	2
8	Screw, Lower Pad Adjuster Zinc-plated	516191-1	1
9	Screw, M5x10 DIN912 A2-70 Hex Socket Head Cap Stainless Steel	F81000-23	1
10	Screw, M8x40-8.8 Hex Socket Head Cap Zinc	F81002-29	2
	Roller, Blade Guide W/Bearing, Extended	092939	1
11	Roller, Blade Guide Extended	087890	1
12	Bearing, 6001 2RSR NACHI	087893	2
13	Ring, W28 Inside Retaining	F81090-9	2

2 BLADE GUIDE ROLLERS & ARM

Blade Guide Assembly, Drive Side

14	Washer, Blade Guide Roller Spacer Zinc-plated	087891-1	1	
	Washer, Blade Guide Roller Spacer Zinc-plated	087892-1	1	
15	Screw, 12/M10x30 12.9 ISO 7379 Socket Head Shoulder	F81003-70	1	
	Screw, 12/M10x35 12.9 ISO 7379 Socket Head Shoulder, (used with the Extended Roller only)	F81003-48	1	
16	Block, Nozzle Mounting Zinc-plated	090487-1	1	
17	Fitting, 90° Elbow 1/8NPT-1/4 Tube Swivel	P09736	1	
18	Nozzle, Blade Lube Spray	033479	2	
19	Plug, M10x1 DIN 906 BN40 "BOSSARD"	F81015-3	2	
20	Screw, M8x20-8.8 Hex Socket Head Cap Zinc	F81002-30	2	
21	Pivot Weldment, Blade Guide Zinc-plated	089509-1	1	
22	Bolt, M8x40 DIN933 A2-70 Stainless Steel	F81002-28	2	
23	Nut, M8 DIN934 A2-70 Stainless Steel	F81032-7	2	
24	Washer, 8.4 Zinc Flat	F81054-1	4	
25	Bolt, M8x25 DIN933 A2-70 Stainless Steel	F81002-26	2	
	Block, Blade Guide Alignment	090951	1	
26	Block, Blade Guide Alignment Zinc-plated	090805-1	1	
27	Screw, M5x16-8.8 Hex Socket Head Cap Zinc	F81000-25	1	
28	Tool, 62860-3 (PERSCHMAN) Lower Pad Adjustment	090949	1	

2.2 Blade Guide Assembly, Drive Side

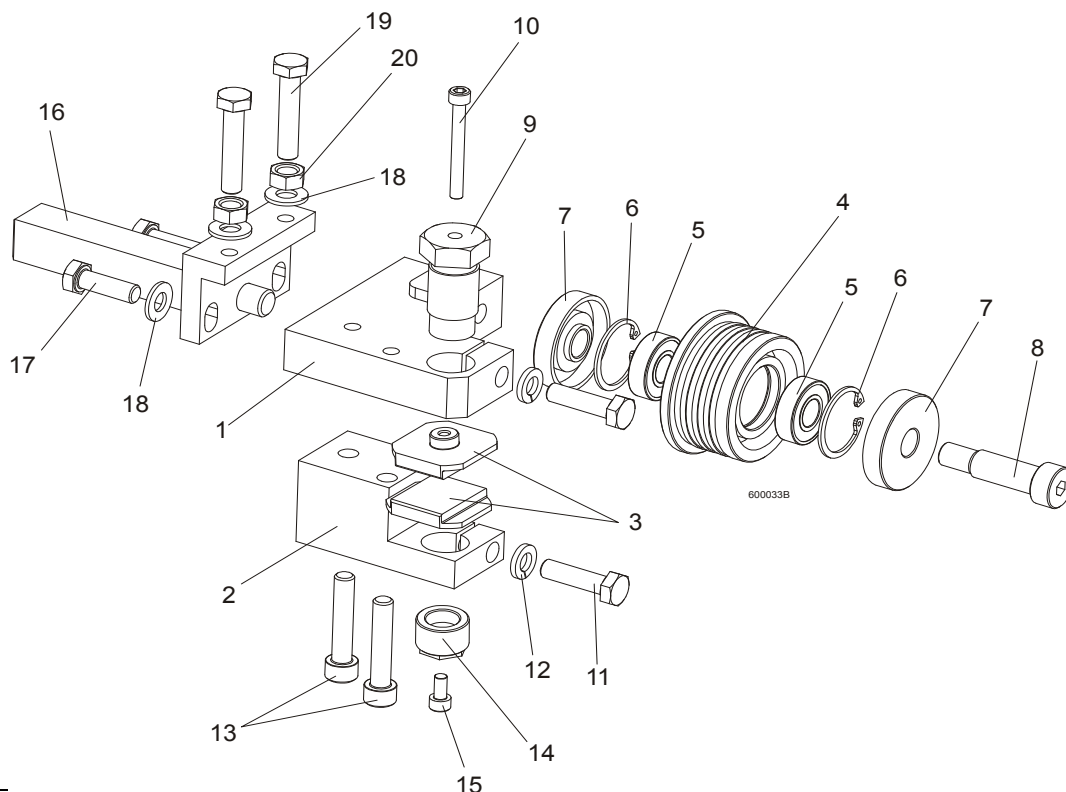

REF.	DESCRIPTION (◆ Indicates Parts Available In Assemblies Only)	PART#	QTY.	
	BLADE GUIDE ASSEMBLY, DRIVE SIDE, EXTENDED (for optional use with 1 1/2" blades)	092998	1	
1	Block, Blade Guide Mount Zinc-plated	090944-1	1	
2	Block, Lower Ceramic Pad Mount Zinc-plated	090946-1	1	

3	Block, Blade Guide Zinc	093430-1	2	
	Roller, Blade Guide W/Bearing, Extended	092939	1	
4	Roller, Blade Guide Extended	087890	1	
5	Bearing, 6001 2RSR NACHI	087893	2	◆
6	Ring, W28 Inside Retaining	F81090-9	2	
7	Washer, Blade Guide Roller Spacer Zinc-plated	087891-1	1	
	Washer, Blade Guide Roller Spacer Zinc-plated	087892-1	1	
8	Screw, 12/M10x30 12.9 ISO 7379 Socket Head Shoulder	F81003-70	1	
	Screw, 12/M10x35 12.9 ISO 7379 Socket Head Shoulder (used with the Extended Roller only)	F81003-48	1	
9	Bolt, Upper Pad Adjustment	089515	1	
10	Screw, M5x45 DIN912 A2-70 Hex Socket Head Cap Stainless Steel	F81000-24	1	
11	Bolt, M8x30 DIN933 A2-70 Stainless Steel	F81002-27	2	
12	Washer, 8.2 Split Lock Zinc	F81054-4	2	
13	Screw, M8x40-8.8 Hex Socket Head Cap Zinc	F81002-29	2	
14	Screw, Lower Pad Adjustment Zinc-plated	516191-1	1	
15	Screw, M5x10 DIN912 A2-70 Hex Socket Head Cap Stainless Steel	F81000-23	1	
16	Pivot Weldment, Blade Guide Zinc-plated	089509-1	1	
17	Bolt, M8x25 DIN933 A2-70 Stainless Steel	F81002-26	2	
18	Washer, 8.4 Zinc Flat	F81054-1	4	
19	Bolt, M8x40 DIN933 A2-70 Stainless Steel	F81002-28	2	
20	Nut, M8 DIN934 A2-70 Stainless Steel	F81032-7	2	

2.3 Blade Guide Arm Drive Assembly

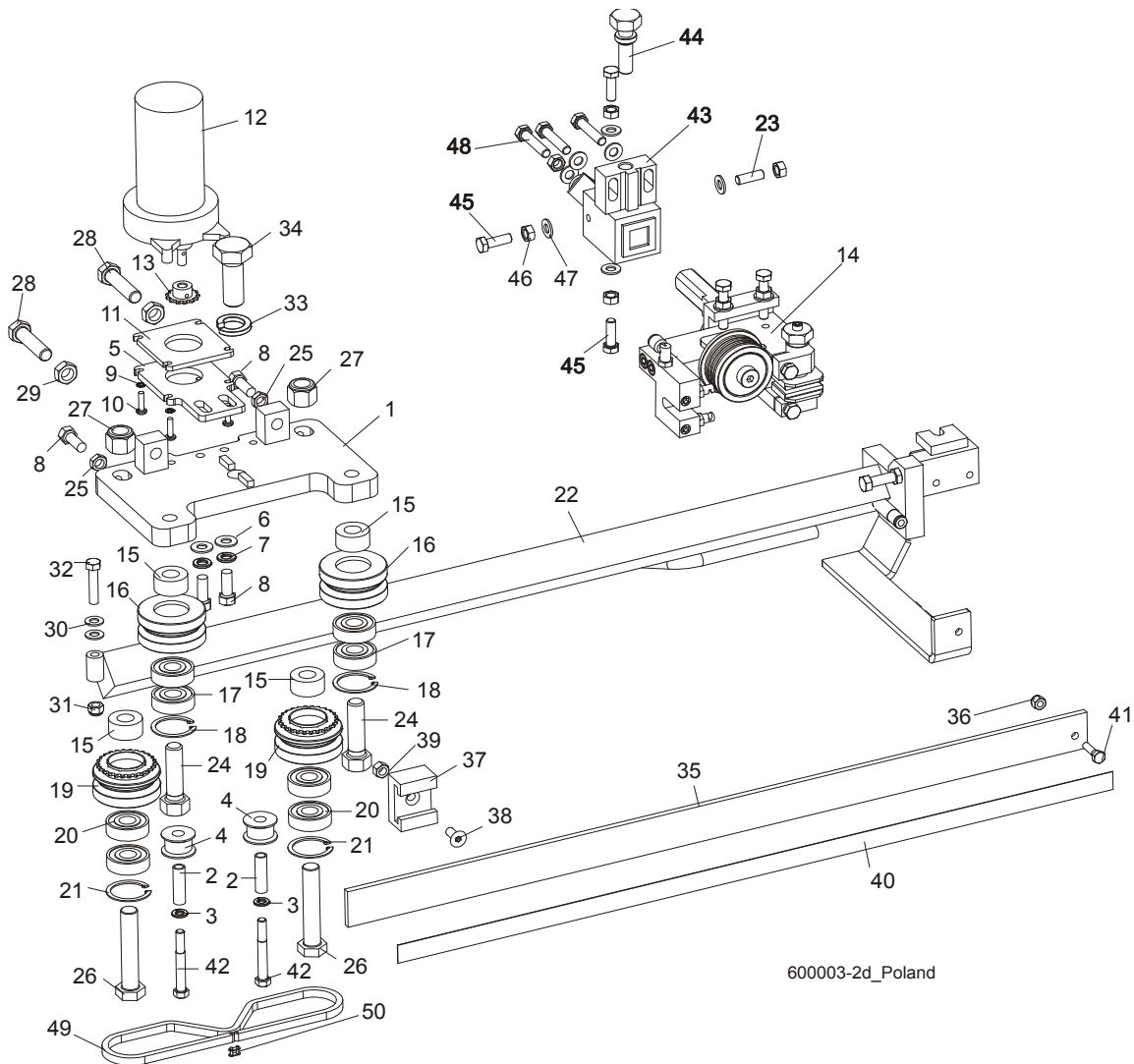

600003-2d_Poland

REF.	DESCRIPTION (◆ Indicates Parts Available In Assemblies Only)	PART#	QTY.
	BLADE GUIDE ARM ASSEMBLY	090950	1
1	Plate Weldment, Blade Guide Arm Zinc-plated	090800-1	1
2	Bushing, 0.322 x 0.44 x 1 1/2" Spacer	S09996	2
3	Washer, 5/16" Split Lock Zinc	F05011-13	2
4	Roller, Chain Guide	090801	2
5	Plate, Blade Guide Motor Mount Ptd	090803-1	1
6	Washer, 10.5 Zinc Flat	F81055-1	2
7	Washer, 3/8" Zinc Flat	F05011-4	2
8	Bolt, M10 x 25 8.8 Hex Head Full Thread	F81003-31	4
9	Washer, 5.3 Zinc Flat	F81052-1	4
10	Screw, #10-32 x 3/4 CrS1 Phillips Head	F05004-38	4
11	Plate, Spacer Ptd	090802-1	1
12	Motor, 53:1 Gear ASA Blade Guide Arm	P09698-1	1
13	Sprocket, 25B13 x .3130	P09970	1
14	Pin, 3 x 14 Zinc Roll	F81044-4	1

BLADE GUIDE ROLLERS & ARM

Blade Guide Arm Drive Assembly

2

15	Spacer, Drive Roller Zinc-plated	090804-1	4	
	ROLLER ASSEMBLY, BLADE GUIDE ARM IDLER	042543	2	
16	Housing, 2 1/2" V-Groove	042536	1	
17	Bearing, 6203 2RSP6-5/8 CX	095087	2	
18	Ring, 1.575" ID 5002-156 Retaining	F04254-8	1	
	ROLLER ASSEMBLY, BLADE GUIDE ARM DRIVE	042542	2	
19	Housing, 2 1/2" V-Groove W/Sprocket	042541	1	
20	Bearing, 6203 2RSP6-5/8 CX	095087	2	
21	Ring, 1.575" ID 5002-156 Retaining	F04254-8	1	
22	Arm Weldment, Blade Guide Zinc-plated	090479-1	1	
23	Screw, Set, M8x8-33H FE/ZN Hex Socket Head, Stainless	F81014-3	1	
24	Bolt, 5/8-18 x 2 1/4 Hex Head Grade 5	F05009-80	2	
25	Nut, M10-04-W Zinc Hex Thin	F81033-6	2	
26	Bolt, 5/8-18 x 3 1/4 Hex Head Grade 5	F05009-80	2	
27	Nut, 5/8-18 Hex Nylon Lock	F05010-71	2	
28	Screw, M12 x 1.25 x 60-33H Zinc Hex Set W/Full Dog Point	F81004-52	2	
29	Nut, M12 x 1.25 8.8 Zinc Hex Thin	F81034-5	2	
30	Washer, 8.4 Zinc Flat	F81054-1	1	
31	Nut, M8-8-B Hex Nylon Zinc Lock	F81032-2	1	
32	Bolt, M8 x 40-8.8 Hex Head Full Thread Zinc	F81002-15	1	
33	Washer, DIN 6319-21C Spherical	F81059-6	1	
34	Bolt, M20 x 1.5 x 50-8.8-B Hex Head Full Thread Zinc	F81007-2	1	
35	Guard, Blade	088306	1	
36	Nut, M6-8-B Hex Nylon Zinc LOKK	F81031-2	1	
37	Guide, Blade Guard	088305	1	
38	Screw, M8 x 25 Cross Recessed Countersunk Head Zinc	F81002-51	1	
39	Nut, M8-8-B Hex Nylon Zinc Lock	F81032-2	1	
40	Decal, Warning	015849	1	
41	Bolt, M6 x 20-8.8 Hex Head Full Thread Zinc	F81001-2	2	
42	Screw, 12/M10 x 20 12.9 ISO7379(BOSSARD) Socket Head Shoulder	F81003-68	2	
43	Mounting Block, LT70 Blade Guide, zinc	089503-1	1	
44	Bolt, Blade Guide Adjustment, zinc	506552-1	1	
45	Bolt, M8x25 DIN933 A2-70, Stainless	F81002-26	3	
46	Nut, M8 DIN934 A2-70, Stainless	F81032-7	5	
47	Washer, 8.4 FLAT,ZINC	F81054-1	7	
48	Bolt M8x40 DIN933 A2-70, Stainless	F81002-28	3	
49	Blade Guide Parts (See Section 2.1)	092997	1	
	Chain, #25 x 92 PITCHES B/G	093805	1	
50	Chain, #25 x 92 Pitches B/G	042443	1	
51	KETTENGLIED #25	P09983	1	

2.4 Blade Guide Mount Assembly, Drive Side

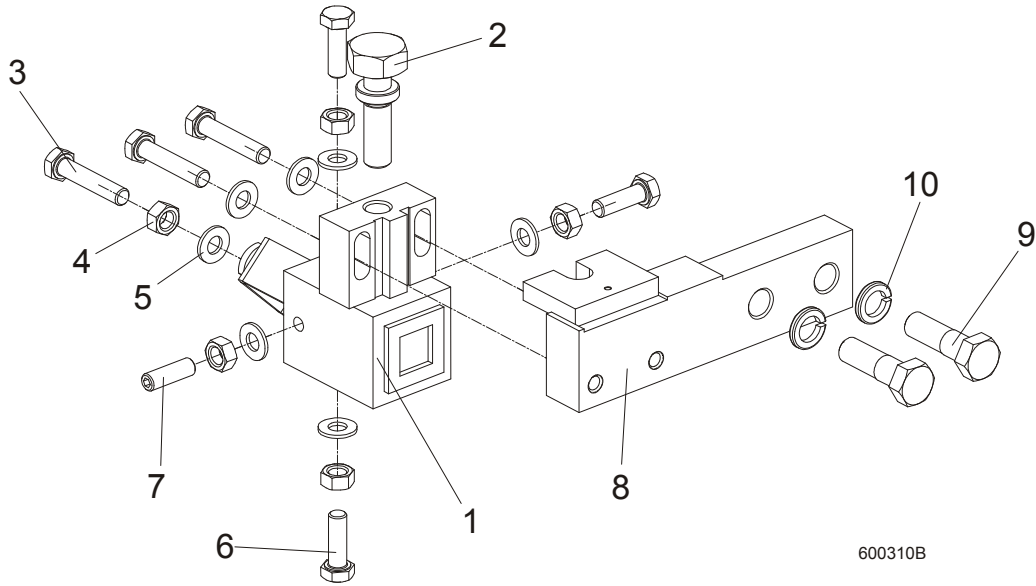

REF.	DESCRIPTION (◆ Indicates Parts Available In Assemblies Only)	PART#	QTY.
	MOUNTING BLOCK, DRIVE SIDE	091338	1
1	MOUNTING BLOCK, BLADE GUIDE, DRIVE SIDE, ZINC	089503-1	1
2	BOLT, BLADE GUIDE ADJUSTMENT, ZINC	506552-1	1
3	BOLT, M8X40 DIN933 A2-70, STAINLESS	F81002-28	3
4	NUT, M8 DIN934 A2-70, STAINLESS	F81032-7	5
5	WASHER, 8.4 FLAT,ZINC	F81054-1	7
6	BOLT, M8X25 DIN933 A2-70, STAINLESS	F81002-26	3
7	SCREW, BLADE GUIDE ADJUSTMENT, M8X25 A2-70 DIN 913, STAINLESS	F81014-3	1
8	BAR, BLADE GUIDE MOUNT, ZINC	089501-1	1
9	BOLT,M12X40-8.8 HEX HEAD ZINC	F81004-1	2
10	WASHER, M12 SPLIT LOCK ZINC	F81056-2	2

SECTION 3 BLADE WHEELS & TENSIONER

3.1 Blade Drive Assembly

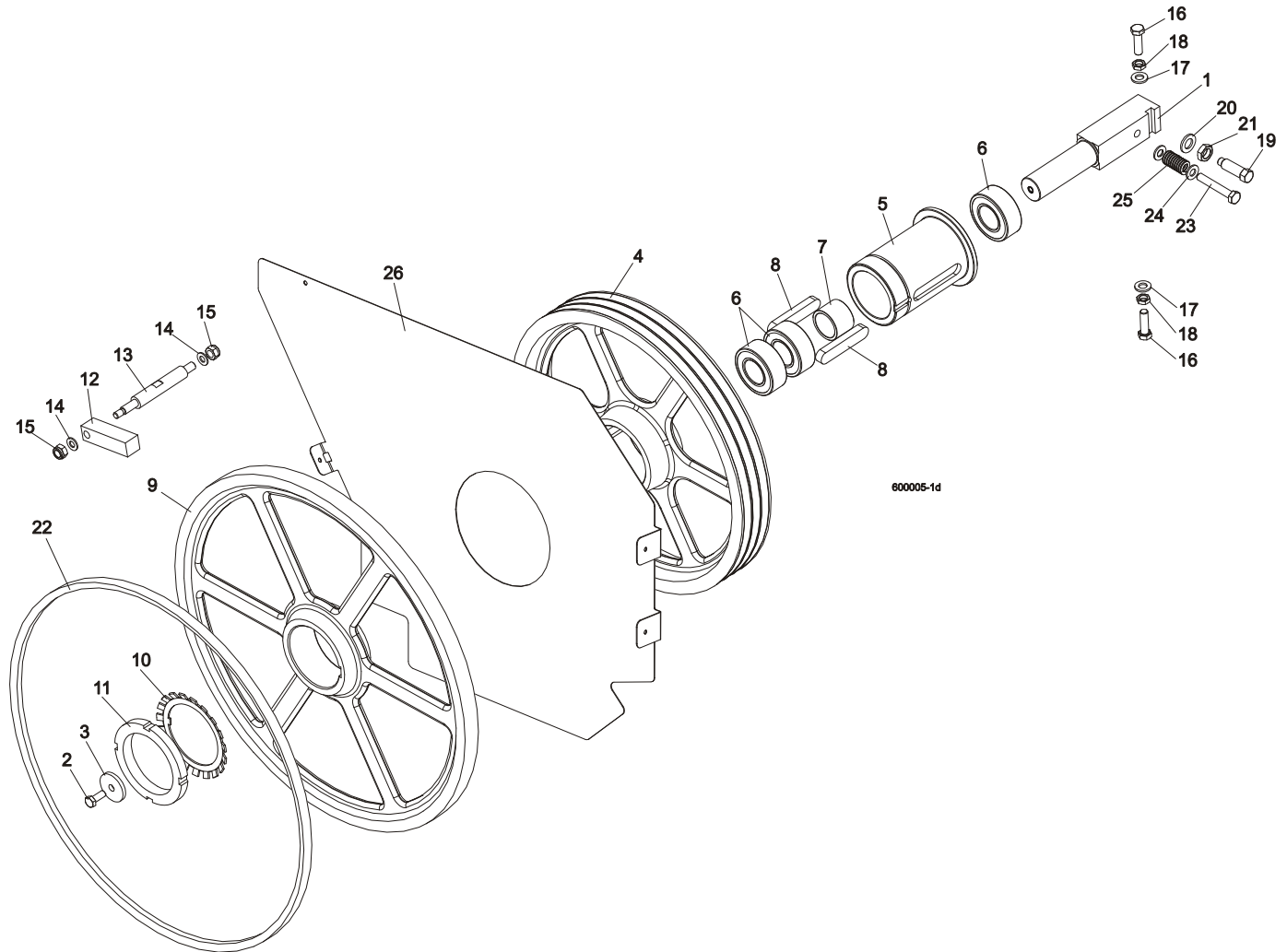

REF	DESCRIPTION (◆ Indicates Parts Available In Assemblies Only)	PART #	QTY.
1	SHAFT, BLADE DRIVE WHEEL	088475	1
2	BOLT, M10x25 8.8 HEX HEAD FULL THREAD	F81003-31	1
3	WASHER, BLADE DRIVE WHEEL	088956-1	1
	PULLEY ASSEMBLY, BLADE DRIVE	504808	1
4	Pulley, 3-Groove 484 mm Diameter	089457-1	1
5	Bushing, Blade Drive Wheel	504809	1
6	Bearing, 3208.2rsr.tvh (FAG) Rolling	088449	3
7	Spacer, 51x41x36.3 Drive Bearing	504810	1
8	Key, A20x12x100 Parallel	088477	2
9	WHEEL, BLADE DRIVE	090811	1
10	WASHER, MB21 (FAG) LOCK	088451	1
11	NUT, KM21(M105X2) (FAG) LOCK	088450	1
12	BAR, WHEEL SCRAPER	088781	1

3

Blade Wheels & Tensioner

Idle Blade Wheel Assembly

13	SHAFT, WHEEL SCRAPER	088780-1	1	
14	WASHER, 10.5 ZINC FLAT	F81055-1	2	
15	NUT, M12-8 HEX NYLON ZINC LOCK	F81034-2	2	
16	BOLT, M12X1.25X40 HEX HEAD	F81004-42	3	
17	WASHER, 13 FLAT ZINC	F81056-1	3	
18	NUT, M12X1.25 8.8 THIN ZINC	F81034-5	3	
19	SCREW, M16X1.5X50-33H HEX HEAD FULL DOG POINT SET ZINC	F81006-14	1	
20	WASHER, 17 ZINC FLAT	F81058-1	1	
21	NUT, M16x1.5-08-B ZINC THIN	F81036-6	1	
22	BELT, BLADE WHEEL B72.5	017922	1	
23	BOLT M10X65	F81003-67	1	
24	WASHER, 10.5 ZINC FLAT	F81055-1	2	
25	SPRING19X38	034430	1	
26	PLATE, LT70AC SAW HEAD (OPTION)	100897-1	1	
	BELT 3B/HB2462 La	089464	1	

3.2 Idle Blade Wheel Assembly

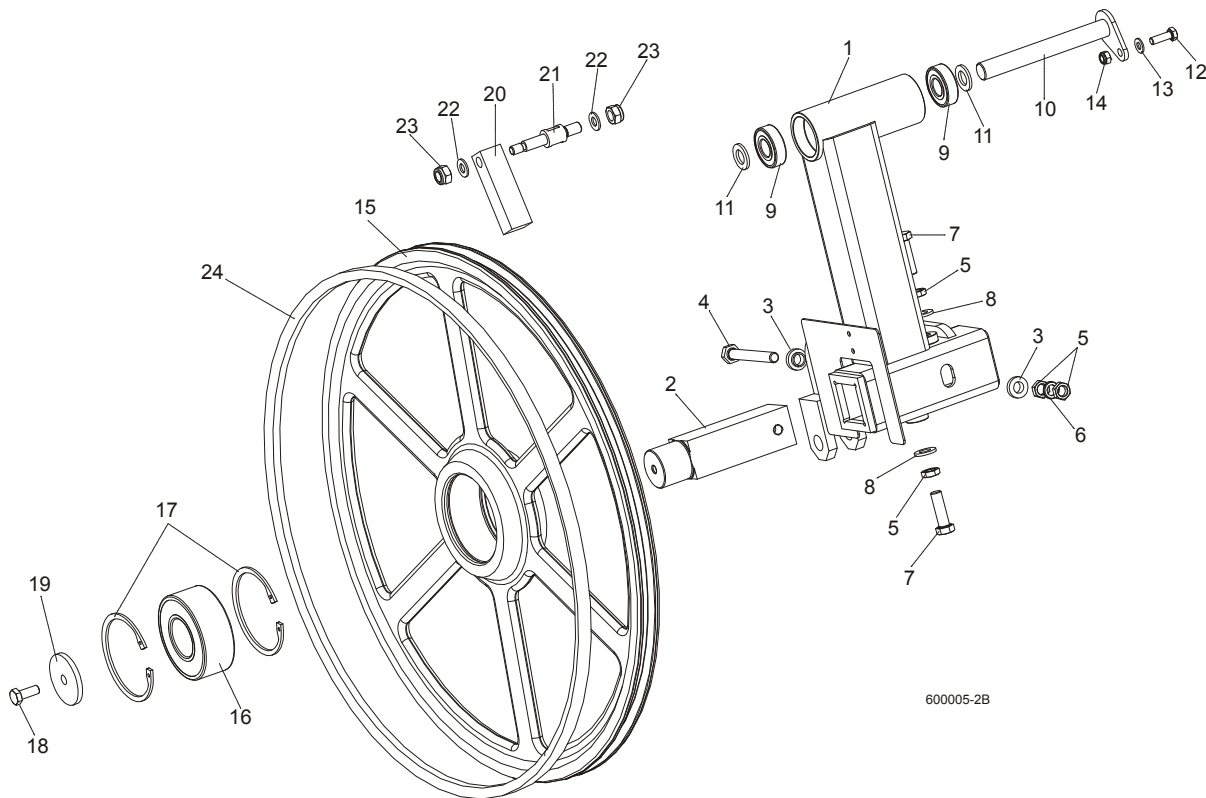

REF	DESCRIPTION (◆ Indicates Parts Available In Assemblies Only)	PART #	QTY.	
	TUBE, LT70 IDLE SIDE BLADE WHEEL W/LEVER COMPLETE	092791	1	
1	Tube Weldment, LT70 Idle Blade Wheel w/Lever	092780-1	1	
2	Shaft, Idle Blade Wheel	088474	1	
3	Washer, Zinc Special	086769-1	2	
4	Bolt, M12x1.25x100-8.8 Hex Head Zinc	F81004-41	1	
5	Nut, M12x1.25 8.8 Hex ZincThin	F81034-5	4	
6	Washer, Z12.2 Split Zinc Lock	F81056-2	1	
7	Bolt, M12x1.25x40 Hex Head	F81004-42	2	

8	Washer, 13 Zinc Flat	F81056-1	2	
9	Bearing, 6204 2RS-CX Rolling	088447	2	
10	PIN WELDMENT, PIVOT	088759-1	1	
11	WASHER, 17 ZINC FLAT	F81058-1	2	
12	BOLT, M8X25-8.8-B HEX HEAD FULL THREAD ZINC	F81002-5	1	
13	WASHER, 8.4 ZINC FLAT	F81054-1	1	
14	NUT, M8-8-B HEX NYLON ZINC LOCK	F81032-2	1	
	WHEEL ASSEMBLY, IDLE SIDE	088764	1	
15	Wheel, Blade Idle Side	090810	1	
16	Bearing, 3309B.2RSR.TVH-P66 FAG	086428	1	
17	Ring, W100 Spring Retaining	F81090-10	2	
18	BOLT, M10X25 8.8 HEX HEAD FULL THREAD	F81003-31	1	
19	WASHER, IDLE BLADE WHEEL RETAINING	088957-1	1	
20	SCRAPER, IDLE BLADE WHEEL	088781	1	
21	SHAFT, SHORT ZINC WHEEL SCRAPER	088779-1	1	
22	WASHER, 10.5 ZINC FLAT	F81055-1	2	
23	NUT, M12-8 HEX NYLON ZINC LOCK	F81034-2	2	
24	BELT, BLADE WHEEL B72.5	017922	1	

3.3 Hydraulic Blade Tensioner Assembly

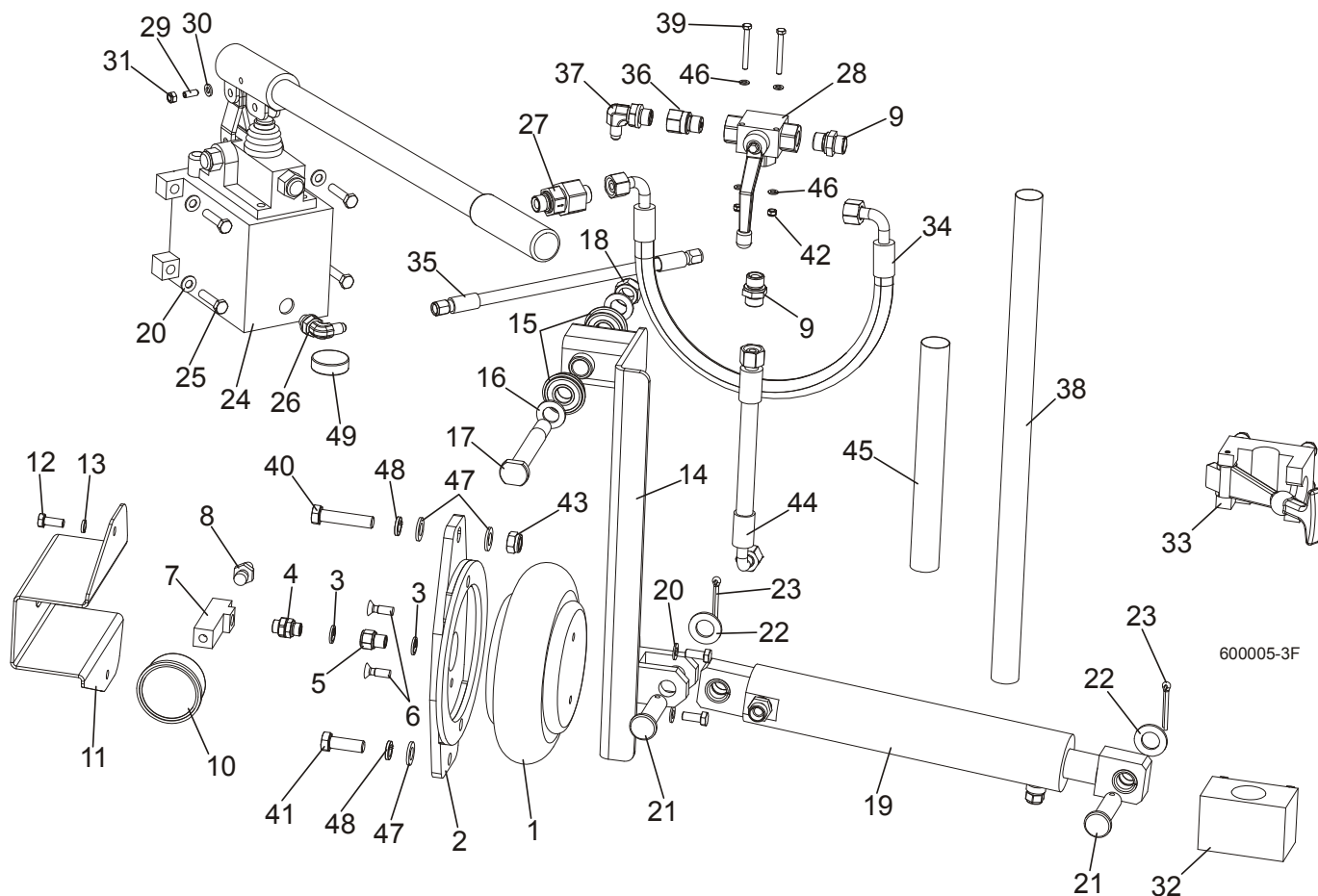

REF	DESCRIPTION (◆ Indicates Parts Available In Assemblies Only)	PART #	QTY.
	HYDRAULIC BLADE TENSIONER, COMPLETE	504801	1
1	BAG, POJ 192 308 100 0 AIR	088576	1
2	BRACKET, AIR BAG MOUNT	088798-1	1
3	SEAL, G1/4 866-014-000-0	090809	4
4	NIPPLE, 1/4 8632141400)BOSCH	097703	1
5	FITTING, 1/4 THREAD/1/4 THREAD 2521	097704	1
6	BOLT, M8X25 PAN HEAD ZINC	F81002-51	2
7	TEE CONNECTOR, SPECIAL	097702-1	1
8	FITTING, 1/4" THREAD 390 004 004 0 (REXROTH) AIR TANK VALVE	088575	1
9	FITTING, HD-GE-12L-BE-06 STRAIGHT	094561	2
10	GAUGE, M63T-2,5/20G G 1/8 0-0,6 MPA/PSI AIR PRESSURE	088568	1
11	GUARD, AIR PRESSURE GAUGE	088924-1	1
12	SCREW, M8X25 CROSS RECESSED COUNTERSUNK HEAD ZINC	F81002-4	4
13	WASHER 8.2 ZINC SPLIT	F81054-4	2
14	ARM, AIR CYLINDER PAINTED	092779-1	1
15	BEARING W/SNAP RING 6203-2RS	086395	2
16	WASHER, 17 FLAT ZINC	F81058-1	2
17	PIN, IDLER ARM MOUNT	086404	1

18	NUT, M16, HEX, NYLON ZINC LOCK	F81036-2	2	
19	CYLINDER, HYDRAULIC COMPLETE	092788	1	
	CYLINDER, SHDJ050/030X80 HYDRAULIC	092787-1	1	
	BUSHING, TUF1 18x120 CX	500106	4	
	FITTING, HD-GE-12L-BE-06 STRAIGHT	094561	1	
	VALVE, 2901-14-17 AIR VENT	090794	1	
20	WASHER, 8.4 ZINC FLAT	F81054-1	6	
21	PIN, PN-EN 22341-B-18X65X57-A2	F81049-4	2	
22	WASHER, 19 FLAT ZINC	F81060-1	2	
23	PIN, S-ZN 5X40 PN-M/82001	F81043-31	2	
24	PUMP, PMS12/TNK1 MANUAL W/TANK 1L	092789-1	1	
25	BOLT, 8MM X 1.25X35MM HH ZINC	F81002-13	4	
26	ELBOW, CA-204410-3	094562	1	
27	VALVE, RHV12LREDA3C CHECK	094559	1	
28	VALVE, BALL 3-WAY RSAP3 VOL2L G3/8"	504803	1	
29	LATCH, GN615.3-M6-KN BALL THREADED	096874	1	
30	WASHER, M6, FLAT, ZINC	F81053-1	1	
31	NUT, M6, HEX, NYLON LOCK ZINC	F81031-2	1	
32	BRACKET, TENSIONER PUMP HANDLE BOTTOM	096951	1	
33	BRACKET, TENSIONER PUMP HANDLE UPPER	092800	1	
34	HOSE, DN10 W/FITTING 10AOL 90 M18X1.5	504804	1	
35	HOSE, 1/4 W/FITTING JIC 7/16-20	504805	1	
36	FITTING, G 3/8 THROTTLE	096849	1	
37	ELBOW, CA-204411-3	094563	1	
38	HOSE PROTECTION	505178	1	
39	BOLT, M5X45 DIN933 A2-70 STAINLESS STEEL	F81000-22	2	
40	BOLT, M12X55-8.8 HEX HEAD ZINC	F81004-12	1	
41	BOLT, M12 X 35-8.8-FE/ZN5 HEX HEAD FULL	F81004-24	1	
42	NUT, M5-8-FE/ZN5 DIN985	F81030-2	2	
43	NUT, M12-8 HEX NYLON ZINC LOCK	F81034-2	1	
44	HOSE, DN12 W/FITTINGS PN10AOL90 I PN10AOL M1.5	096964	1	
45	HOSE PROTECTION	098489	1	
46	WASHER, 5.3 FLAT ZINC	F81052-1	4	
47	WASHER, 13 FLAT ZINC	F81056-1	3	
48	WASHER, Z12.2 SPLIT LOCK ZINC	F81056-2	2	
49	MAGNET, MW.38X12/N38 NEODYMIUM	500022	1	

3.4 Sawdust Flow Guide

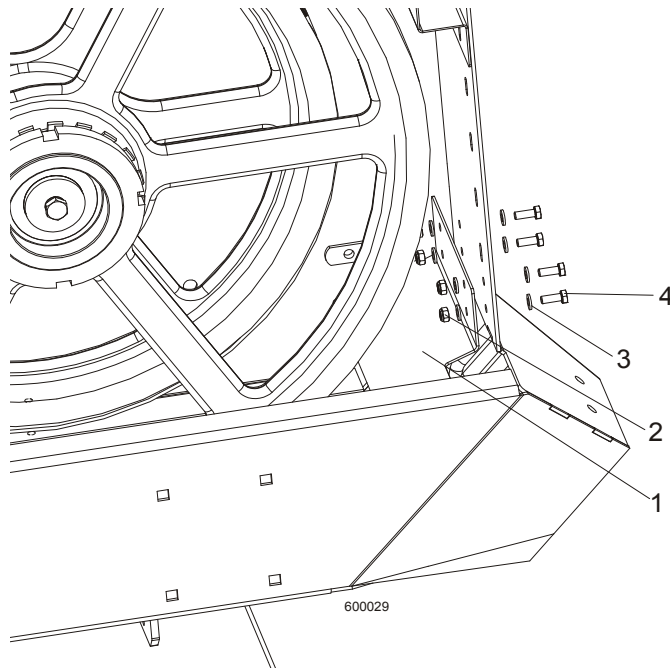

REF	DESCRIPTION (◆ Indicates Parts Available In Assemblies Only)	PART #	QTY.
1	GUIDE, SAWDUST FLOW PAINTED	090506	1
2	NUT, M6-8-B HEX NYLON ZINC LOCK	F81031-2	4
3	WASHER 6.4 ZINC FLAT	F81053-1	8
4	BOLT, M6 X 16 8.8 FE/ZN5 PN-M/82105	F81001-15	4

SECTION 4 SAW HEAD

4.1 Middle Throat Screw

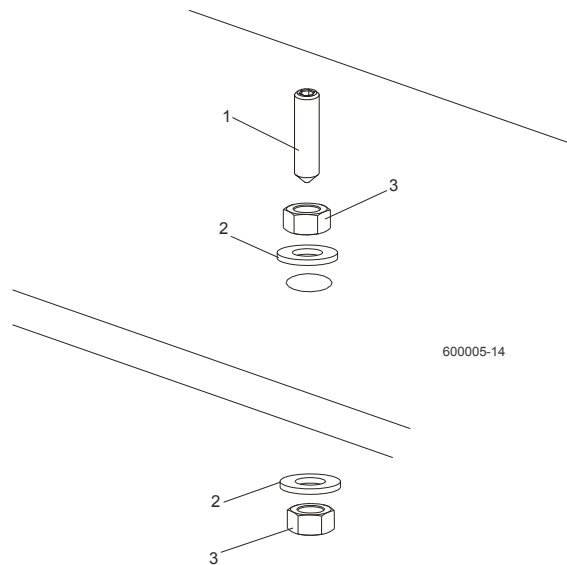

REF	DESCRIPTION (◆ Indicates Parts Available In Assemblies Only)	PART #	QTY.
1	SCREW, M10X40-45H HEX SOCKET SET CONE POINT ZINC	F81003-61	1
2	WASHER, 10.5 ZINC FLAT	F81055-1	2
3	NUT, M10-8-B ZINC HEX	F81033-3	2

4.2 Drive Belt Tensioner LT70 AC

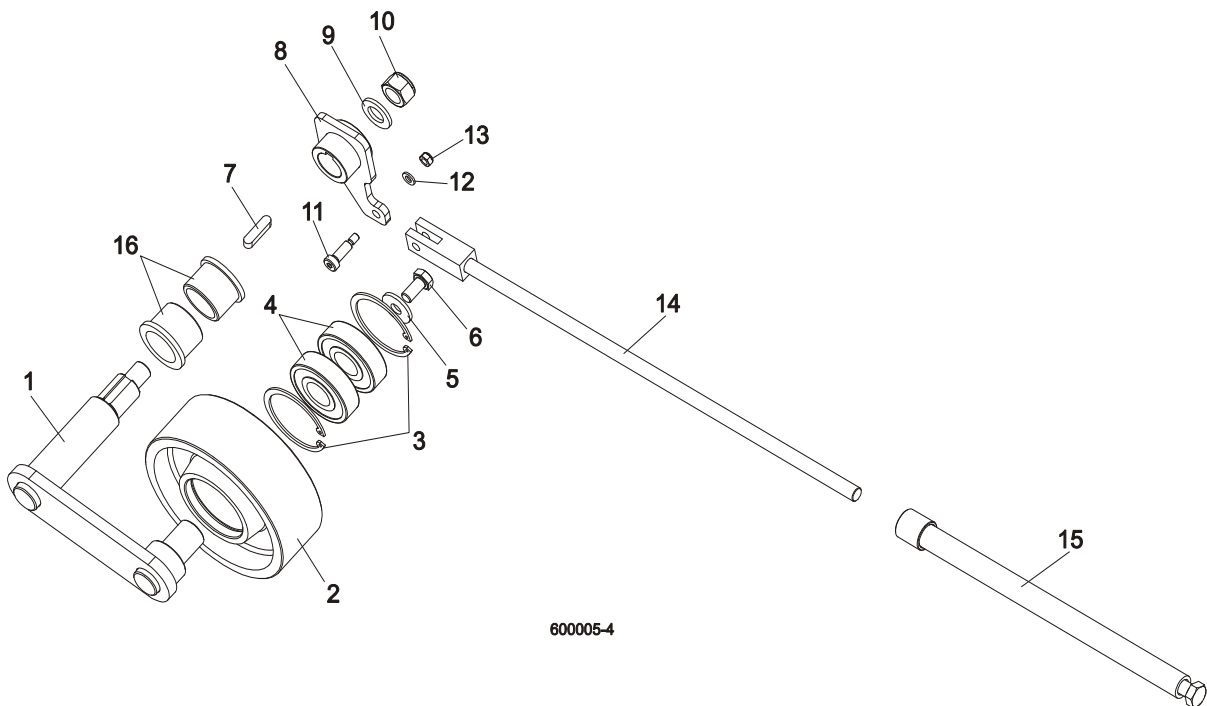

REF	DESCRIPTION (◆ Indicates Parts Available In Assemblies Only)	PART #	QTY.
	TENSIONER ASSEMBLY, DRIVE BELT	508761	1
1	Pivot Weldment, Drive Belt Tensioner	509885-1	1

4

SAW HEAD

Board Return Assembly (Optional)

2	Wheel, Belt Tension	508762	1	
3	Ring, 62 mm Inside Spring Retaining	F81090-1	2	
4	Bearing, 6305 2RS NSK	P08066	2	
5	Washer, 11 Dia. Zinc Flat Special	088787-1	1	
6	Bolt, M10x20-5.8 Hex Head Full Thread Zinc	F81003-1	1	
7	Key, A8X7X32 Parallel	088564	1	
8	Arm Weldment, Drive Belt Tensioner	088807-1	1	
9	Washer, 17 Zinc Flat	F81058-1	1	
10	Nut, M16-5.8 Zinc Hex	F81036-2	1	
11	Bolt, 8/M6X20 12.9 ISO 7379 BOSSARD	F81001-25	1	
12	Washer 6.4 Zinc Flat	F81053-1	1	
13	Nut, M6-8-B Hex Nylon Zinc Lock	F81031-2	1	
14	Rod Weldment, Threaded Zinc-Plated	088789-1	1	
15	Tube Weldment, Threaded Zinc-Plated	088782-1	1	
16	BUSHING, MFM-3240-30	088461	2	

4.3 Board Return Assembly (Optional)

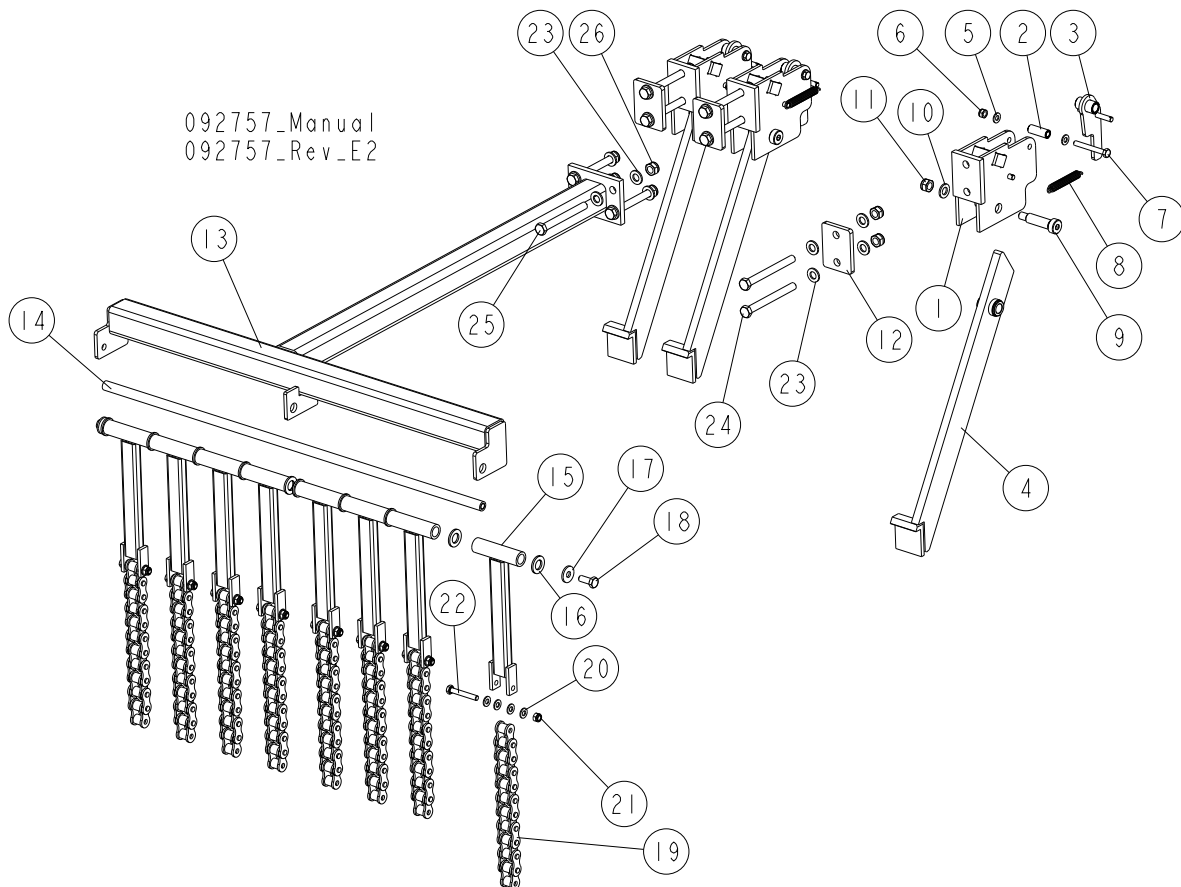

	DESCRIPTION (* Indicates Parts Available In Assemblies Only)	PART #	QTY	
	BOARD RETURN ASSEMBLY	092757	1	
	BOARD, RETURN ASSEMBLY	090120	3	
1	MOUNT WELDMENT, BOARD RETURN ARM	090109-1	1	

	DESCRIPTION (* Indicates Parts Available In Assemblies Only)	PART #	QTY	
2	SPACER, ZINC	090115-1	1	
3	LATCH WELDMENT, BOARD RETURN ARM	090118-1	1	
4	ARM, BOARD RETURN	090112-1	1	
5	WASHER, 8.4 FLAT ZINC	F81054-1	2	
6	NUT, M8-8-B HEX NYLON ZINC LOCK	F81032-2	1	
7	BOLT, M8 X 65MM,HH,GRADE 5.8, ZINC	F81002-3	1	
8	SPRING, EXT 1/2X2 1/4X.06	014817	2	
9	BOLT, 16/M12X50-12.9 ISO7379-BOSSARD SOCKET HEAD	F81004-25	1	
10	WASHER, 13 FLAT ZINC	F81056-1	1	
11	NUT, M12-8 HEX NYLON ZINC LOCK	F81034-2	1	
12	WASHER, SPECIAL	092756-1	3	
	GUIDE, BOARD RETURN	514162	1	
13	GUIDE WELDMENT, BOARD RETURN	091067-1	1	
14	ROD, BOARD RETURN GUIDE	091074	1	
15	BAR WELDMENT, BOARD GUIDE UPPER	091070-1	8	
16	WASHER, 17 FLAT ZINC	F81058-1	10	
17	WASHER,10.5 ZINC FLAT SPECIAL	F81055-6	2	
18	BOLT, M10 X 25 8.8 FE/ZN5, PN-M/82105	F81003-31	2	
19	CHAIN 16B-1 - 0.28M	514163	8	
20	WASHER, 8.4 FLAT ZINC	F81054-1	32	
21	NUT, M8-8-B HEX NYLON ZINC LOCK	F81032-2	8	
22	BOLT, M8 X 55 8.8 FE/ZN5, PN-M/82101	F81002-8	8	
23	WASHER, 13 FLAT ZINC	F81056-1	20	
24	BOLT M12X120 8.8 FE/ZN5	F81004-38	6	
25	BOLT,M12X110-8.8-B-FE/ZN5 PN-85/M82101	F81004-47	4	
26	NUT, M12-8 HEX NYLON ZINC LOCK	F81034-2	10	

4.4 Water Lube Assembly

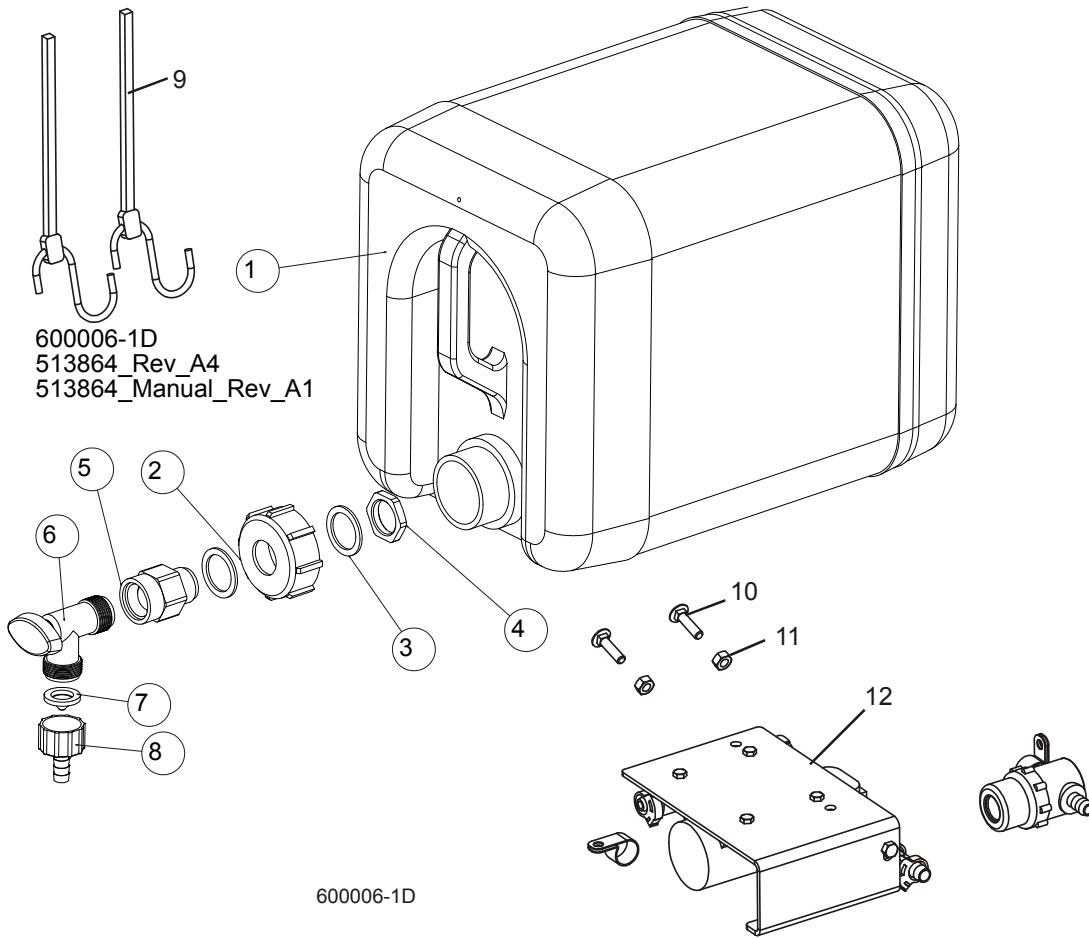

REF	DESCRIPTION (◆ Indicates Parts Available In Assemblies Only)	PART #	QTY.
	BOTTLE, WATER, COMPLETE.	513864	1
	BOTTLE, WATER, WITH NUT.	513865¹	1
1	BOTTLE, WATER	513866	1
2	NUT, BOTTLE.	513867	1
3	SEAL, RUBBER 35x26x2.	513869	2
4	NUT, PACKING 3/4 NPT.	513868	1
5	Fitting, 3/4FPT x 3/4MPT Reducer	014636	1
6	Fitting, Water Lube Shutoff Valve	014100	1
7	Filtr NUT	016086	1
8	FITTING, 5/8" NPT TO 3/8" HOSE BARB	014113	1
9	STRAP, 20" RUBBER	P11668	2
10	BOLT, 1/4-20 X 1" CARRIAGE HEAD	F05005-34	2
11	NUT, 1/4-20 HEX LOCK	F05010-21	2
12	LUBEMIZER PARTS/HOSES (SEE LUBEMIZER OPTION MANUAL)		

¹ The service number 513865-S includes: 513865, 513869, 513868

4.5 LT70AC Saw Head Decals

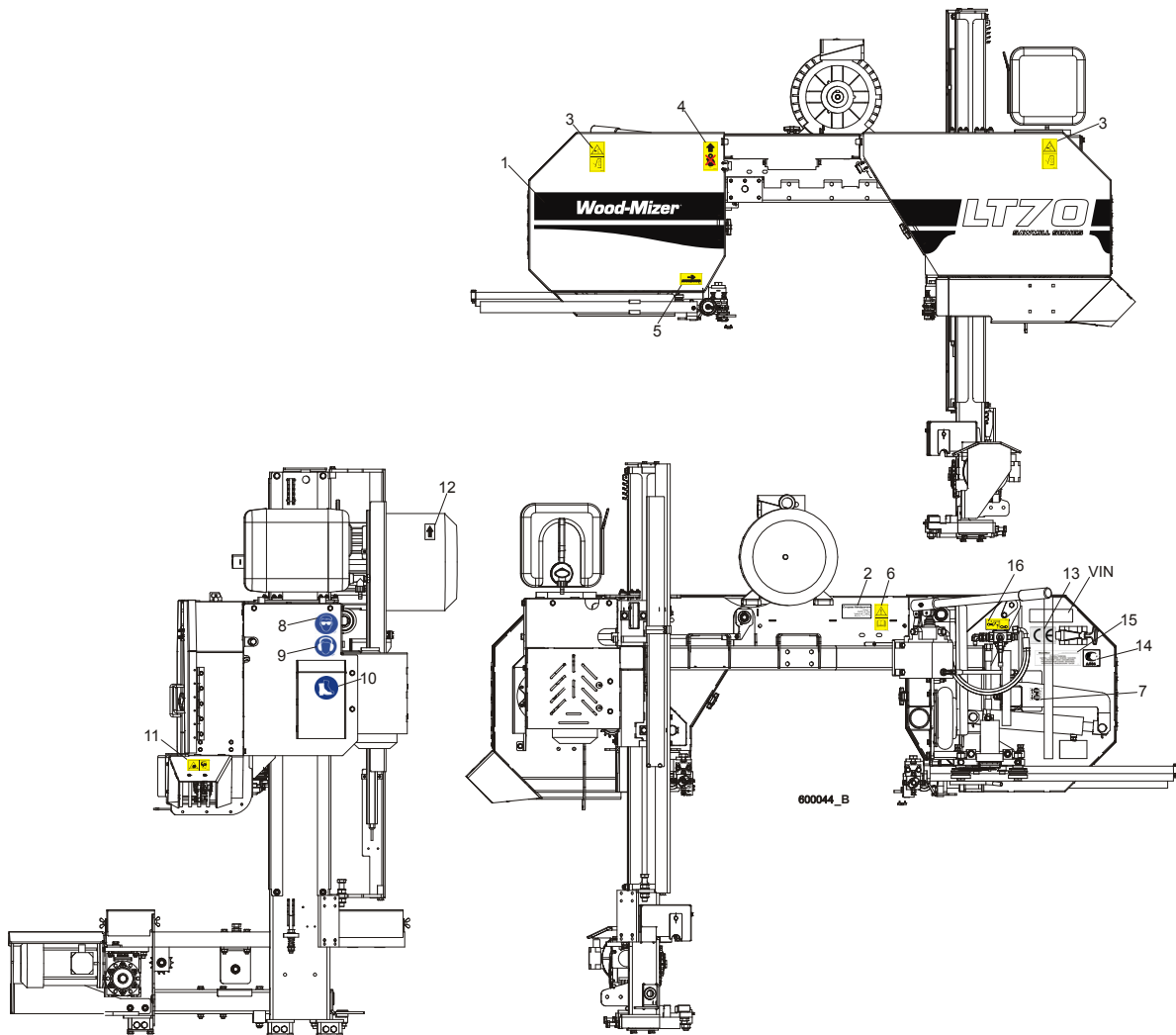

REF	DESCRIPTION (◆ Indicates Parts Available In Assemblies Only)	PART #	QTY.
1	DECAL, LT70 SERIES SAWMILL	092764	1
	PICTOGRAPHIC DECAL KIT, LT70AC	099518	1
2	DECAL, EUROPEAN HEADQUARTERS ADDRESS	015841	1
3	DECAL, SAWMILL COVERS CAUTION (PICTOGRAM)	099220	2
4	DECAL, PICTOGRAM (BLACK ARROW & HOOK)	085977B	1
5	DECAL, BLADE MOVEMENT DIRECTION (PICTOGRAM)	096321	1
6	DECAL, READ OPERATOR'S MANUAL (PICTOGRAM)	096317	1
7	DECAL, BLADE ALIGNMENT (PICTOGRAM)	P11789-70	1
8	DECAL, EYE PROTECTION WARNING (PICTOGRAM)	S12004G	1
9	DECAL, EAR PROTECTION WARNING (PICTOGRAM)	S12005G	1
10	DECAL, USE SAFETY BOOTS (PICTOGRAM)	501465	1
11	DECAL, SAWDUST CHUTE WARNING (PICTOGRAM)	099222	1
12	DECAL, MOTOR ROTATION DIRECTION	S20097	1

4

SAW HEAD*LT70AC Saw Head Decals*

13	DECAL, CE CERTIFIED SAWMILL	P85070	2	
14	DECAL, RUSSIAN SAFETY CERTIFICATION	099401	1	
15	DECAL, INTERNATIONAL SAWMILL NAME	501466	1	
16	DECAL, LEVER OF TENSIONER'S BALL VALVE	505189	1	
	DECAL, HIGH VOLTAGE INSIDE THE ELECTRIC BOX (PICTOGRAM)	096316	2	
	DECAL, REMOVE THE PLUG BEFORE OPENING THE BOX (PICTOGRAM)	096319	2	
	DECAL, STAY A SAFE DISTANCE FROM THE BLADE (FOR DEBARKERS)	098176	1	
	DECAL, BLADE SETTING	P85066-70	1	
	DECAL, KEEP AWAY DANGER, PICTOGRAM	099221	1	
	DECAL, MAX. OIL PRESSURE, PICTOGRAM	099524	1	

4.6 Blade Housing Covers

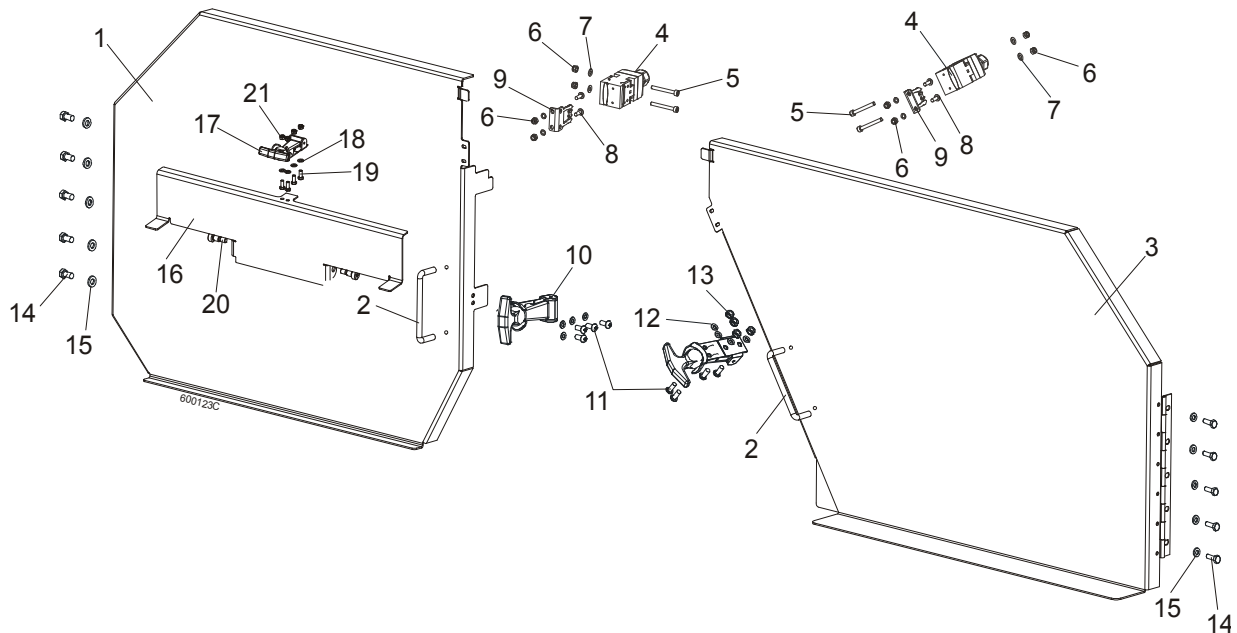

REF	DESCRIPTION (◆ Indicates Parts Available In Assemblies Only)	PART #	QTY.
	COVER ASSEMBLY, IDLE SIDE BLADE HOUSING	088920	1
1	Cover Assembly, Idle Side Blade Housing, Ptd	088915-1	1
2	Handle, Blade Housing Cover	P08065	1
	COVER ASSEMBLY, DRIVE SIDE BLADE HOUSING	088921	1
3	Cover Assembly, Drive Side Blade Housing, Ptd	088917-1	1
2	Handle, Blade Housing Cover	P08065	1
4	LIMIT SWITCH, HONEYWELL GKMB 23W2	086681	2
5	BOLT, M4 X 35-8.8 SOCKET HEAD	F81011-34	4
6	NUT, M4-B HEX NYLON ZIN	F81028-2	8
7	WASHER 4,3 ZINC, FLAT	F81051-2	8
8	SCREW, M4 X 12-5.8	F81011-41	4
9	KEY, AZ17/170-B5 SAFETY SWITCH	094422	4
10	LATCH, FLEXIBLE DRAW	014829	2
11	BOLT, M5X12-5.8	F81000-5	8
12	WASHER 5,3 ZINC FLAT	F81052-1	8
13	NUT M5-8 DIN 985 ZINC	F81030-2	8
14	BOLT, M6X16 8.8 HEX HEAD FULL THREAD ZINC	F81001-15	10
15	WASHER 6.4 ZINC FLAT	F81053-1	10
	COVER BLADE UP LT70, COMPLETE	511536¹	1
16	PLATE UP COVER LT70, PAINTED	511802-1	1
17	Latch, Flexible Draw	014829	1
18	WASHER 5.3 FE/ZN5 PN-78/M-82005	F81052-1	2
19	BOLT, M5 X 12-5.8-Fe/Zn5, PN-M/82105	F81000-5	4
20	BOLT, 10/M8 X 12-12.9 ISO-7379	F81003-62	2
21	NUT, M5-8-Fe/Zn5 DIN985	F81030-2	2

¹ Belongs to 088771 and 88770

4.7 Sawdust Chute

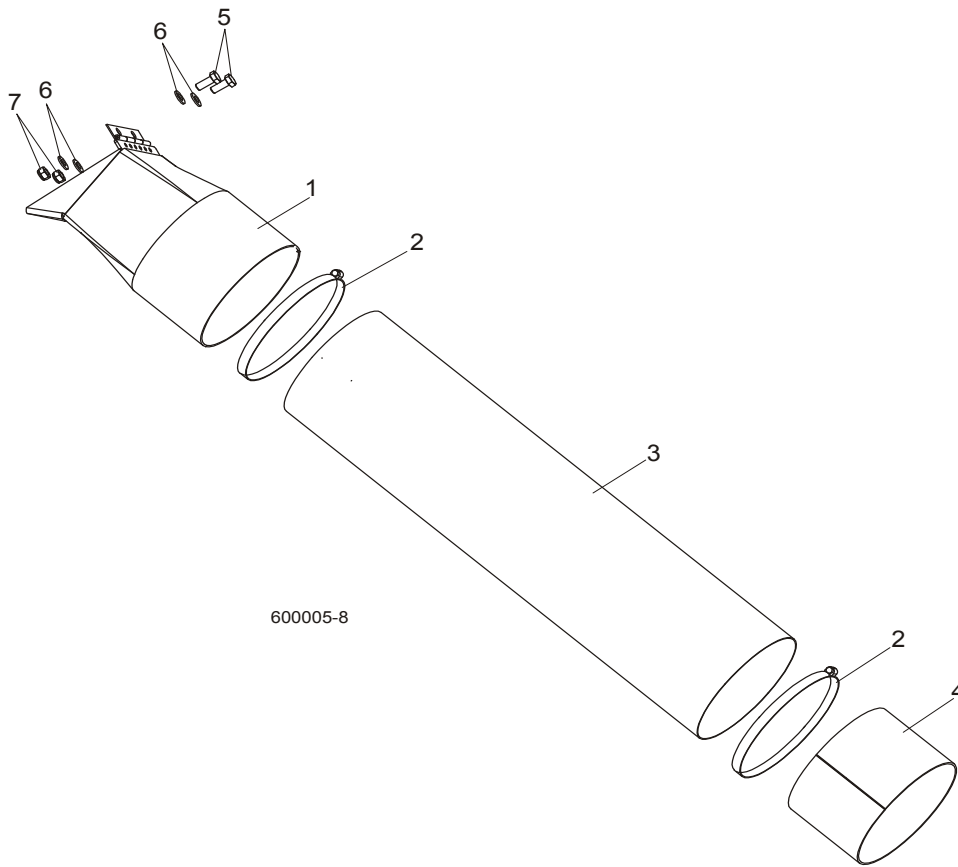

REF	DESCRIPTION (◆ Indicates Parts Available In Assemblies Only)	PART #	QTY.
1	CHUTE WELDMENT, SAWDUST	089352-1	1
2	CLAMP, 152 MM	089358	2
3	TUBE, SAWDUST CHUTE	090153	1
4	TUBE, CHUTE END	090126-1	1
5	BOLT, M8X20-8.8-B HEX HEAD FULL THREAD ZINC	F81002-4	2
6	WASHER 8.4 ZINC FLAT	F81054-1	4
7	NUT, M8-8-B HEX NYLON ZINC LOCK	F81032-2	2

4.8 Saw Head Protection Kit, LT70L Mobile

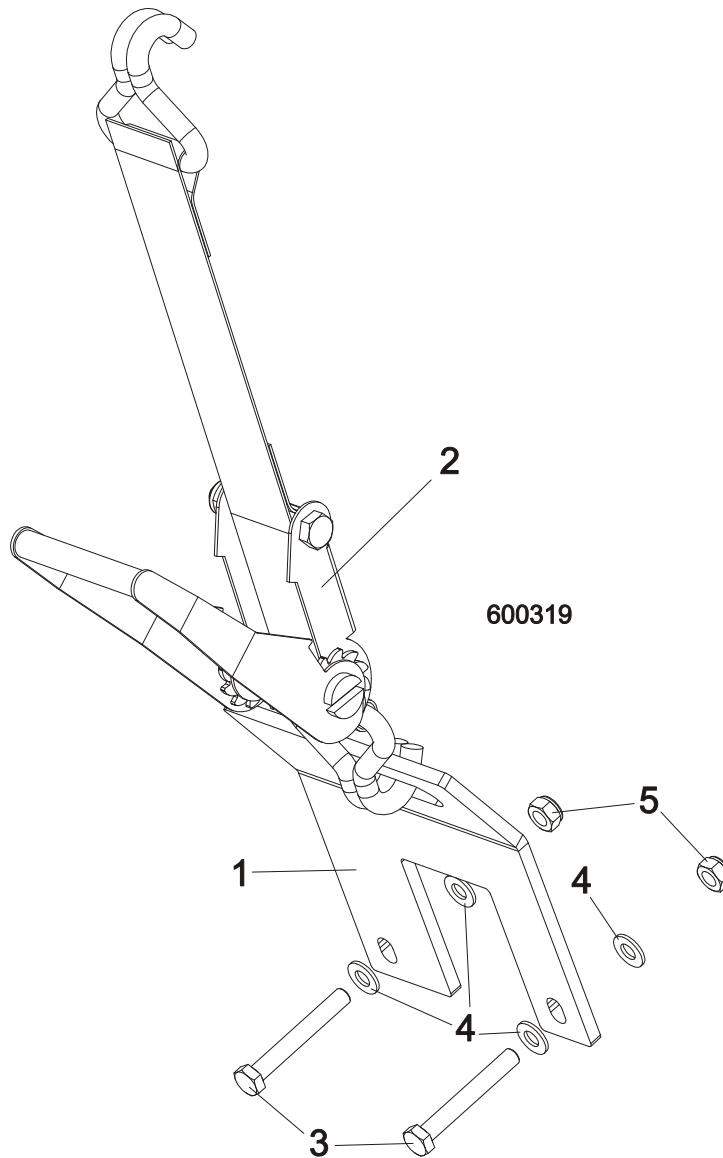

REF	DESCRIPTION (◆ Indicates Parts Available In Assemblies Only)	PART #	QTY.
	SAW HEAD PROTECTION KIT, LT70L MOBILE	505565	1
1	BRACKET, PROTECTION BELT-PAINTED	505549-1	1
2	BELT, LT70 SAW HEAD PROTECTION	505563	1
3	BOLT, M10x75-8.8-Fe/Zn5 PN-M/82101	F81003-15	2
4	WASHER, 10.5 FLAT ZINC	F81055-1	4
5	NUT, M10-8-B NYLON HEX ZINC LOCK	F81033-1	2

SECTION 5 CONTROL & BATTERY BOXES

5.1 Control Assembly, LT40AC Series

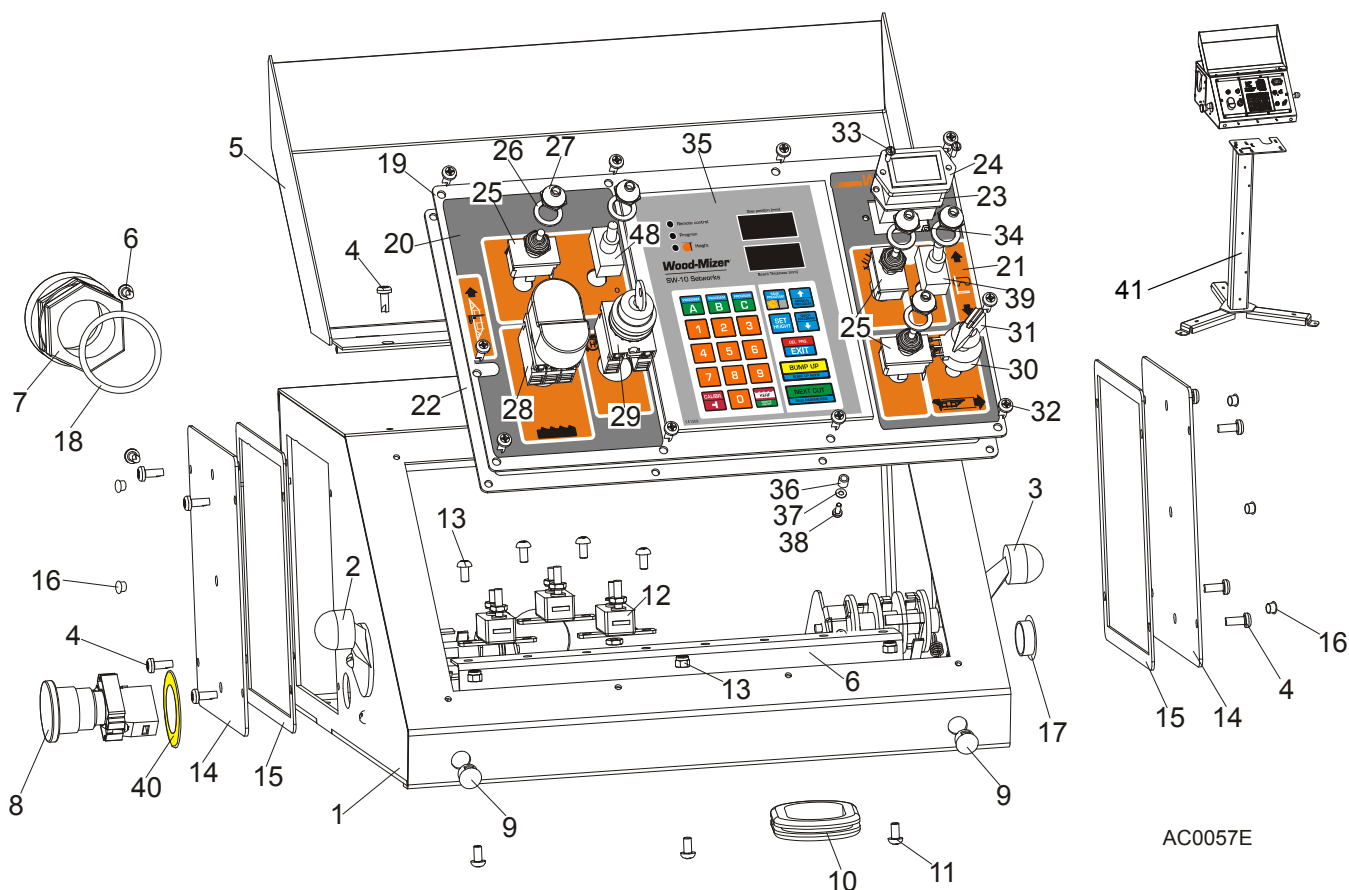

REF	DESCRIPTION (◆ Indicates Parts Available In Assemblies Only)	PART #	QTY.
	CONTROL BOX ASSEMBLY, LT40 AC	098690	1
	CONTROL BOX ASSEMBLY, LT40 AC-RC	509115	1
1	Control Box, LT40AC	099622-1	1
2	Switch, 1992GS Pwr/Feed (Service Package)	E20438	1
3	Switch, 1992 Up/Down (Service Package)	E20440	1
4	Bolt, #10-24x1/2 Ph Pan Hd, Type 23	F05015-17	12
5	Cover Weldment, LT20/40 Complete	097135-1	1
6	Rail, Circuit Breaker	015310	1
7	Connector, 1 1/4 Straight Metal Conduit	024402	1
8	Switch, XB2 BS542 Emergency	086556	1
9	Switch, Speed Control	086773	2
10	Grommet, Rubber	087065	1
11	Screw, H M5x10 8.8 Zinc	F81000-13	7
12	Breaker, 15A Manual Reset	E20430	3
13	Nut, M5-8 Zinc	F81030-2	3
	Cover, Control Box Side Complete	086700	2

14	Cover, Control Box Side	086699-1	1	
15	Gasket, Control Box Side	015274	1	
16	Cap, SR1086 6.4 Dia. Hole	099700	6	
17	Cap, SR1086 22.2 Dia. Hole	093544	1	
18	Seal, 1 1/4 Ring LQTI w/Retainer	015430	1	
	Panel, LT40 AC Front Control Complete	098689	1	
19	Panel, LT20/40 AC Front Control	100572-1	1	
	Panel, LT40 AC Front Control	098586-1 ¹	1	
20	Decal, LT20/40 AC Control Box Left	099594	1	
21	Decal, LT40 DC Control Box Right	099596	1	
22	Gasket, LT20/40 Control Box	097132	1	
23	Gasket, Hour Meter	093346	1	
24	Meter, Hour	093166	1	
25	Switch, Toggle	024200	3	
26	Washer, 1/2x3/4x1/16 Nylon	P05251-1	5	
27	Boot, Toggle Switch	P02575	5	
28	Button, 24V Start/Stop	090452	1	
	Membrane M22-T-DD	090462	1	
29	Switch, M22 3-position Key	091361	1	
30	Potentiometer, 1k Feed Rate	E20519	1	
31	Knob, Speed Control	P06257	1	
32	Bolt, #10-24x1/2 Ph Pan Hd, Type 23	F05015-17	10	
33	Bolt, M3x12-8.8 Zinc	F81000-12	2	
34	Nut, M3-6 Nylon Zinc Lock	F81028-2	2	
35	Controller, SW-10 Setworks	500628	1	
36	Spacer, 4.2x6mm Idler	R80671-4	6	
37	Washer, 3.2 Flat Zinc	F81050-2	6	
38	Screw, M3x8-4.8 Zinc	F81000-83	6	
39	Switch, SPST On/Off 15A .25 TABS Toggle	P03027	2	
40	EMERGENCY STOP DECAL	086793	1	
41	STAND CONTROL BOX LT20/40/LES/EG300/TVS	501651-1 ²	1	

¹ Use in African version only.

² Used In **509115**

5.2 Control Assembly, LT70 AH

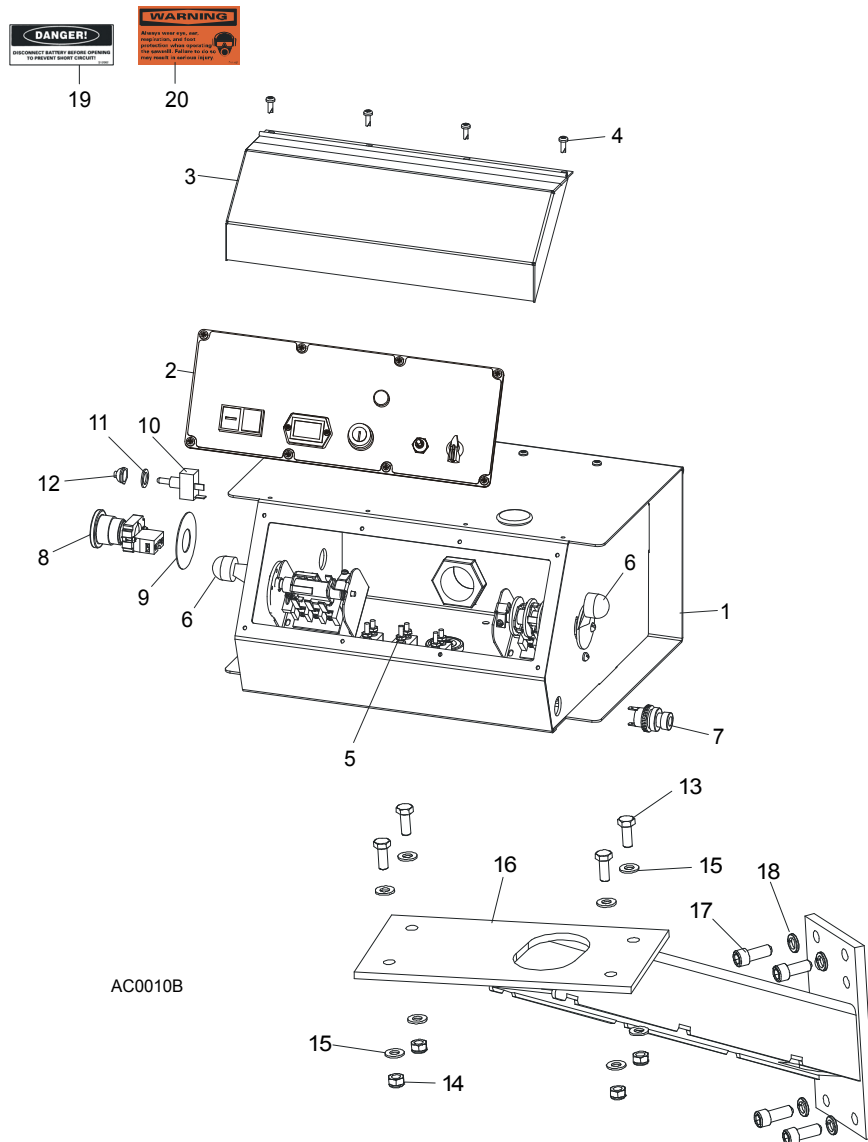

REF	DESCRIPTION (◆ Indicates Parts Available In Assemblies Only)	PART #	QTY.	
	CONTROL BOX ASSEMBLY, AC SUPER (EA20, EA25)	093022	1	
1	HOUSING, AC SUPER CONTROL BOX ASSEMBLY (EA20, EA25)	086546-1	1	◆
2	Front Control Panel & Wiring Harnesses (Section 5.5)			
3	Cover, Control Box Hinged	015304	1	
4	Screw, #10-24 x 1/2"	F05015-17	12	
5	Circuit Breakers (Section 5.5)			
6	Drum Switches (Section 5.3)			
7	Switch, Horn	E85118	1	
8	Switch, XB2 BS542 Emergency Stop	086556	1	
9	Washer, Emergency Stop Switch	086561	1	
10	Switch, Speed Control	086773	1	
11	Washer, 1/2" x 3/4" x 5/8" Nylon	P05251-1	1	
12	Boot, Speed Control Switch	P02575	1	
13	BOLT, M8 X 20-8.8-B HEX HEAD	F81002-4	4	

14	NUT, M8-8-B HEX	F81032-2	4	
15	WASHER, 8.4 FLAT	F81054-1	8	
16	MOUNT WELDMENT, STANDARD CONTROL BOX	086732-1	1	
17	BOLT,, 3/8-16 X 1" SOCKET HEAD	F05007-52	4	
18	WASHER, 10.2 SPLIT LOCK	F81055-2	4	
19	DECAL, FRONT OUTRIGGER WARNING	015400-4	1	
20	DECAL, EAR/EYE PROTECTION WARNING	S11753-4	1	

5.3 Control Box Bracket

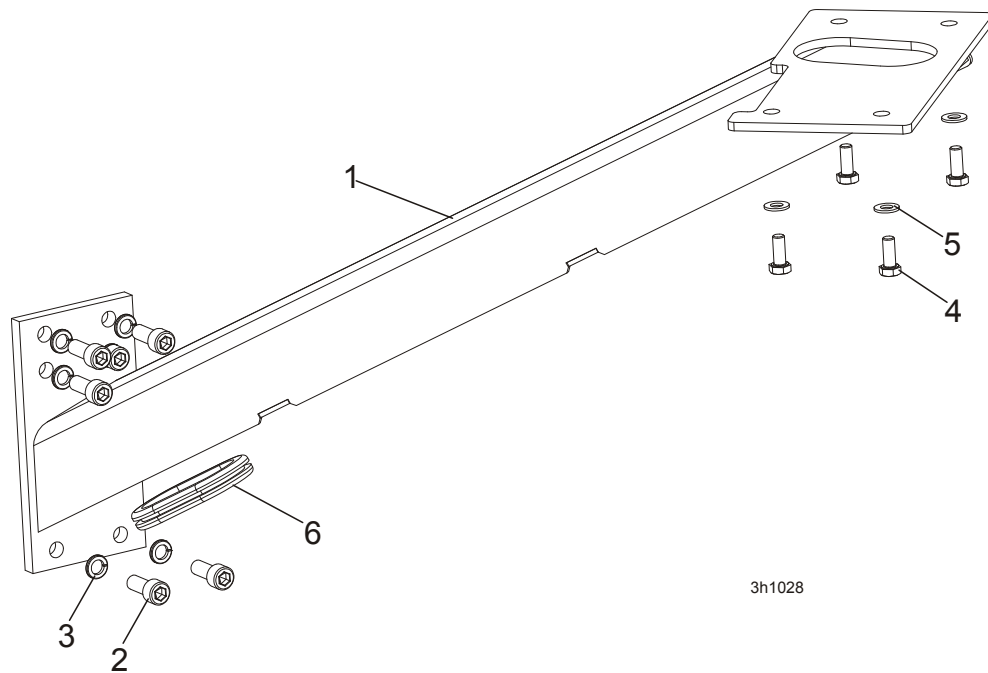

REF	DESCRIPTION (◆ Indicates Parts Available In Assemblies Only)	PART #	QTY.
1	MOUNT WELDMENT, STANDARD CONTROL BOX	086732-1	1
2	BOLT, M10x25 8.8 ZINC SOCKET HEAD	F81003-32	6
3	WASHER,10.2 SPLIT LOCK ZINC	F81055-2	6
4	BOLT, M8X20MM HEX HEAD,GR 5.8 ZINC	F81002-4	4
5	WASHER, 8.4 FLAT ZINC	F81054-1	4
6	GROMMET, RUBBER	087065	1

5.4 Drum Switches

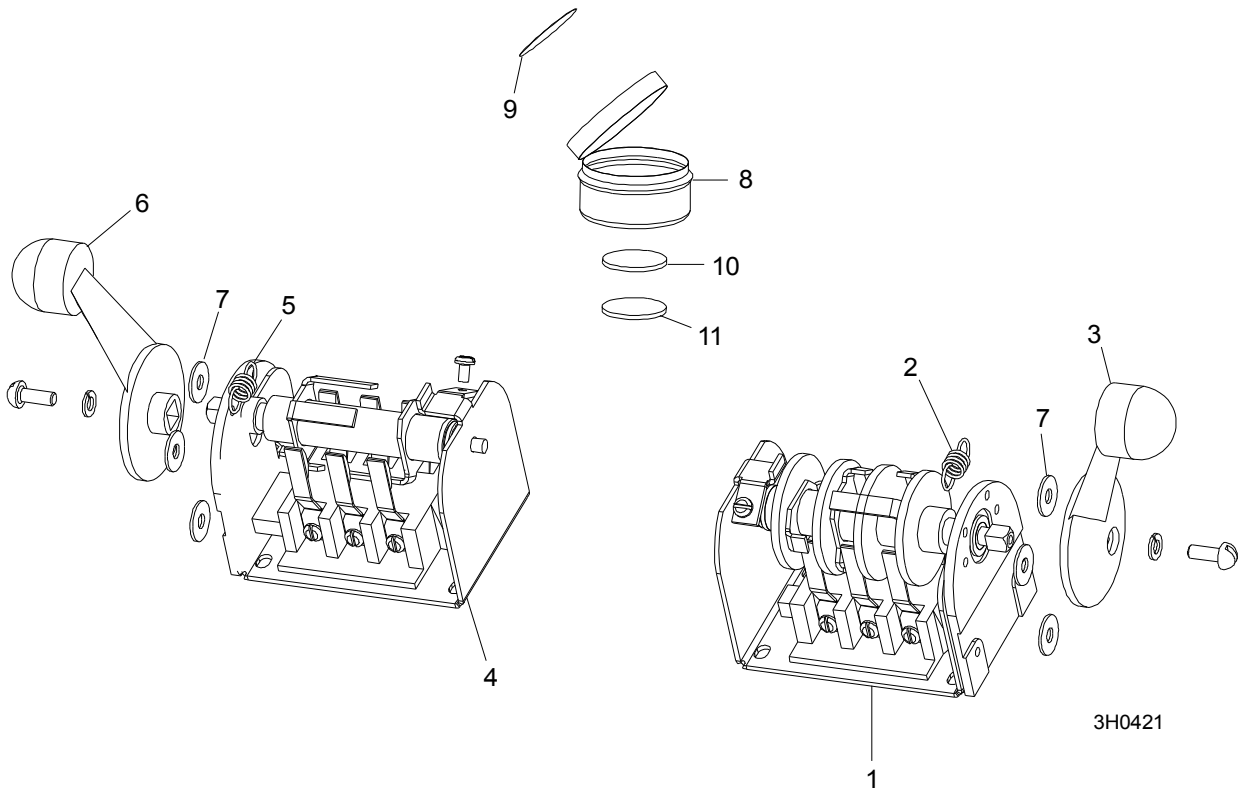

REF	DESCRIPTION (◆ Indicates Parts Available In Assemblies Only)	PART #	QTY.	
	SWITCH ASSEMBLY, UP/DOWN DRUM	E20440	1	
1	Switch, S12 Bulk Drum	E20440-B	1	◆
2	Spring, Drum Switch	P12570	1	
3	Handle, Drum Switch Replacement	P12500	1	
	SWITCH ASSEMBLY, POWER FEED DRUM	E20438	1	
4	Switch, S10 Bulk Drum	E20438-B	1	◆
5	Spring, Drum Switch	P12570	1	
6	Handle, Drum Switch Replacement	P12500	1	
7	WASHER, #8 SAE FLAT	F05011-41	6	
	CUP ASSEMBLY, DRUM SWITCH GREASE	A20463	1	
8	Cup, Plastic Container	P20464	1	◆
9	Decal, Grease Cup Label	P20467	1	
10	Pad, Velcro Loop	P20466	1	◆
11	Pad, Velcro Hook	P20465	1	◆
	Grease, High Temp Drum Switch	P20468	.011ml	◆

5.5 Circuit Breakers

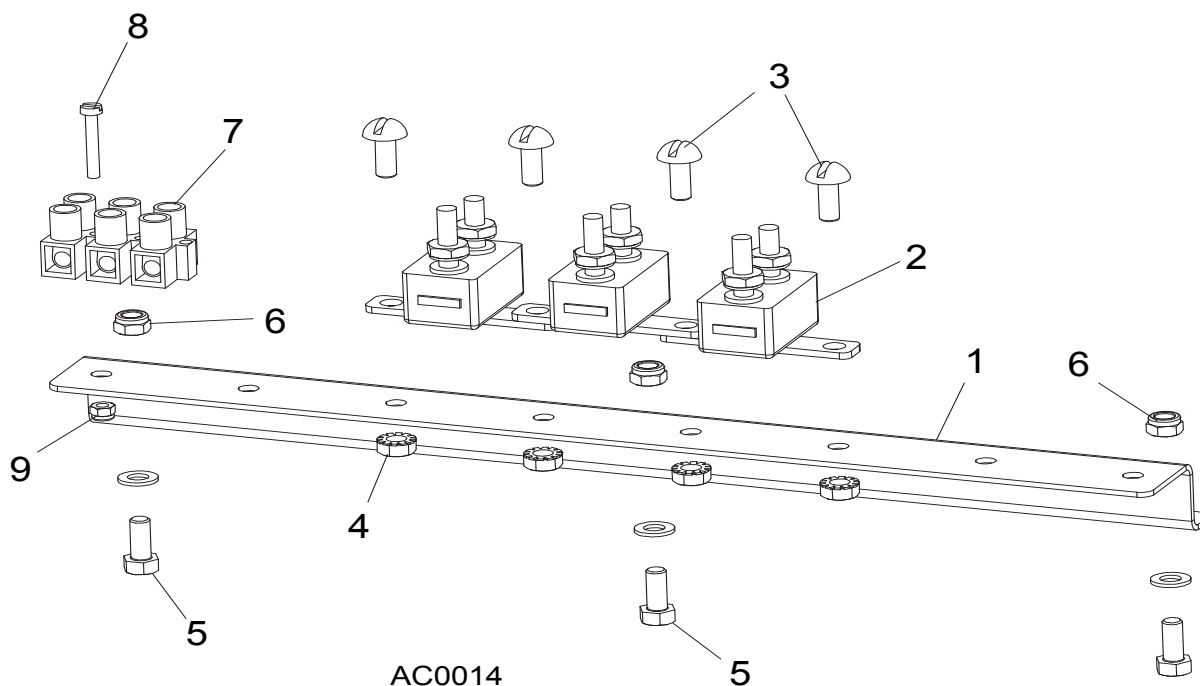

REF	DESCRIPTION (◆ Indicates Parts Available In Assemblies Only)	PART #	QTY.
1	RAIL, CIRCUIT BREAKER	015310	1
2	BREAKER, 15 AMP MANUAL RESET	E20430	5
3	SCREW, H M5X10 8.8 ZINC	F81000-13	4
4	NUT, M5-8 ZINC HEX SELF-LOCKING	F81030-2	4
5	SCREW, M5X12-5.8 ZINC	F81000-5	3
6	NUT, M5-8 ZINC HEX SELF-LOCKING	F81030-2	3
7	STRIP, ELECTRIC WIRE	F81086-1	1
8	SCREW, M3 X 20-5.8	F81000-8	1
9	NUT, M3	F81028-2	1

SECTION 6 UP/DOWN SYSTEM

6.1 Up/Down Rollers & Covers

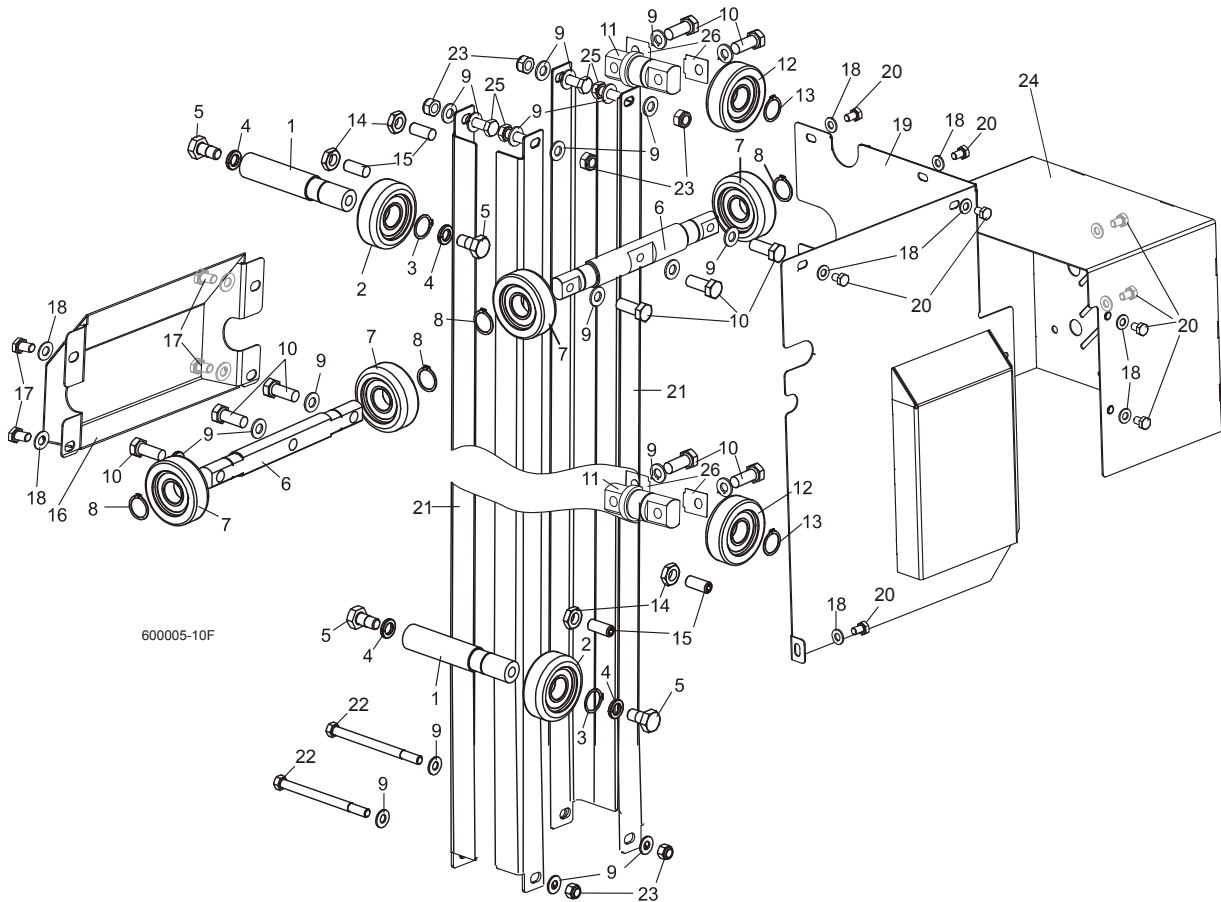

REF	DESCRIPTION (◆ Indicates Parts Available In Assemblies Only)	PART #	QTY.
	ROLLER ASSEMBLY, INSIDE UP/DOWN	089456	2
1	Shaft, Inside Up/Down Roller	088817-1	1
2	Bearing, CBK-468 Rolling	088433	1
3	Ring, Z30 Spring Retaining	F81090-23	1
4	Washer, 13 Zinc Flat	F81056-1	2
5	Bolt, M12x25-8.8 Hex Head Full Thread Zinc	F81004-31	2
	ROLLER ASSEMBLY, OUTSIDE UP/DOWN	089454	2
6	Shaft, Long Up/Down Roller	088815-1	1
7	Bearing, CBK-468 Rolling	088433	2
8	Ring, Z30 Spring Retaining	F81090-23	2
9	Washer, 10.5 Zinc Flat	F81055-1	22
10	Bolt, M10x35-8.8 Hex Head Full Thread Zinc	F81003-17	10
	ROLLER ASSEMBLY, SHORT UP/DOWN	089455	2
11	Shaft, Short Up/Down Roller	088816-1	1
12	Bearing, CBK-468 Rolling	088433	1
13	Ring, Z30 Spring Retaining	F81090-23	1
14	NUT, M10-04-W HEX ZINC THIN	F81033-6	4
15	SCREW, GN 913.3-M10-40-MS SET	F81003-65	4
16	COVER WELDMENT, UP/DOWN ROLLER	507056-1	1

6 Up/Down System

Blade Height Scale

17	BOLT, M8X16-8.8-B HEX HEAD FULL THREAD ZINC	F81002-20	4	
18	WASHER, 8.4 ZINC FLAT	F81054-1	13	
19	GUARD WELDMENT, RA-08 UP/DOWN GEAR BOX SIDE PTD	091319-1	1	
20	BOLT, M8X12-8.8 HEX HEAD FULL THREAD ZINC	F81002-6	9	
21	ANGLE, MAST TUBE STAINLESS	088492	4	
22	BOLT, M10X125-8.8 HEX HEAD ZINC	F81003-18	2	
23	NUT, M10-8-B HEX NYLON ZINC LOCK	F81033-1	6	
24	GUARD, UP/DOWN MOTOR PAINTED	090501-1	1	
25	BOLT, M10X30-5.8 HEX HEAD FULL THREAD	F81003-2	4	
26	SPACER, ROLLER ASSEMBLY, SHORT UP/DOWN	510616	-	

6.2 Blade Height Scale

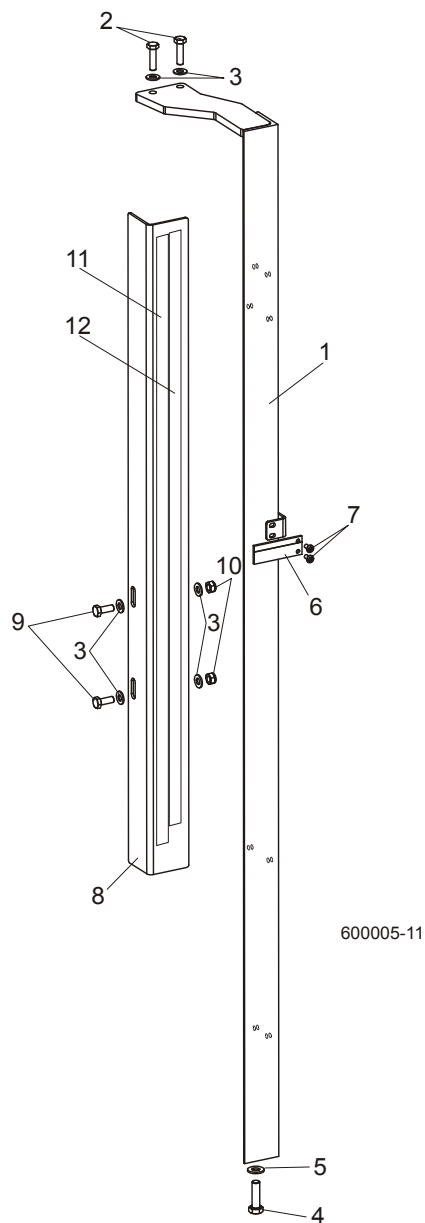

REF	DESCRIPTION (◆ Indicates Parts Available In Assemblies Only)	PART #	QTY.	
1	MOUNT WELDMENT, SCALE PAINTED	088554-1	1	

2	BOLT, M8 x 30-8.8-B HEX HEAD FULL THREAD ZINC	F81002-7	2	
3	WASHER, 8.4 ZINC FLAT	F81054-1	6	
4	BOLT, M10 x 35-8.8 HEX HEAD FULL THREAD ZINC	F81003-17	1	
5	WASHER, 10.5 ZINC FLAT	F81055-1	1	
6	INDICATOR, BLADE HEIGHT SCALE	094821	1	
7	SCREW, #10-24 X 3/8 PHILLIPS PAN HEAD ZINC	F05004-3	2	
8	ANGLE, SCALE MOUNT	088785-1	1	
9	BOLT, M8 X 20-8.8-B HEX HEAD FULL THREAD ZINC	F81002-4	2	
10	NUT, M8-8-B HEX NYLON ZINC LOCK	F81032-2	2	
11	DECAL, METRIC SCALE	S11711	1	
12	DECAL, 16-40 MM METRIC SCALE	P12040-1	1	

6.3 Up/Down Chain & Sprockets

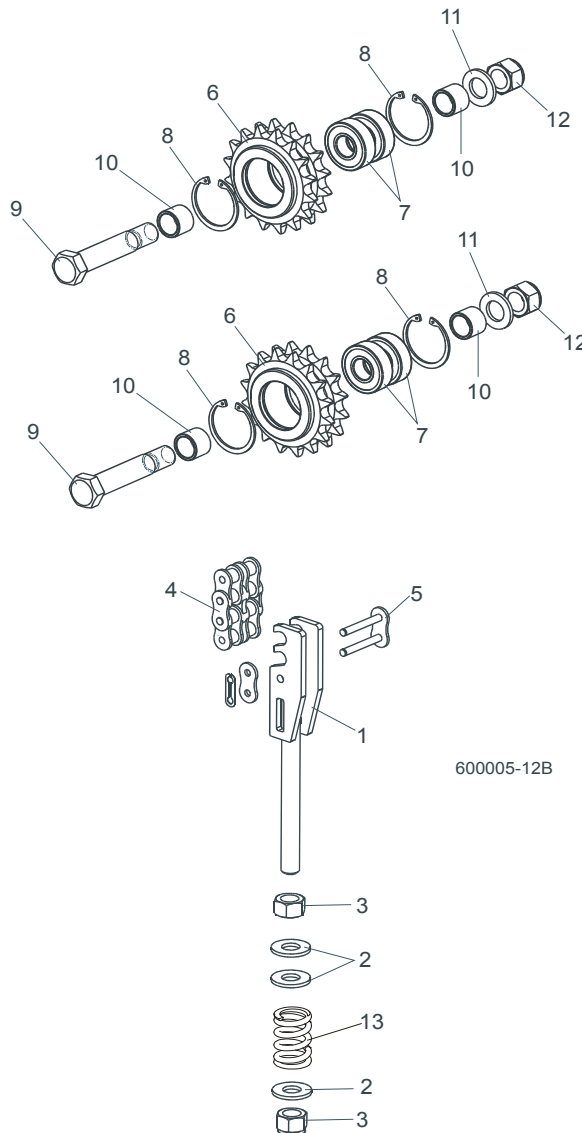

REF	DESCRIPTION (◆ Indicates Parts Available In Assemblies Only)	PART #	QTY.	
1	TENSIONER WELDMENT, UP/DOWN CHAIN ZINC	512181-1	1	
2	WASHER, 13 ZINC FLAT	F81056-1	3	
3	NUT, M12-8 HEX NYLON ZINC LOCK	F81034-2	2	

6 Up/Down System

Up/Down Drive Assembly

4	CHAIN, 12B-2 97-LINK	512197	1	
5	LINK, 12B-2Pz MASTER	099249	1	
	SPROCKET ASSEMBLY, UP/DOWN IDLER	512180	2	
6	Sprocket, Zinc-plated	512179-1	1	
7	Bearing, 6203-2RS FLT Rolling	086114	2	
8	Ring, W40 Spring Retaining	F81090-3	2	
9	Bolt, M16D1F6 x 90-8.8 Hex Fit Short Thread Zinc	F81006-15	1	
10	Spacer, Idler Zinc	088792-1	2	
11	Washer, 17 Zinc Flat	F81058-1	1	
12	Nut, M16-8 Hex Nylon Zinc Lock	F81036-2	1	
13	Spring, 14x30x3,2	090797	1	

6.4 Up/Down Drive Assembly

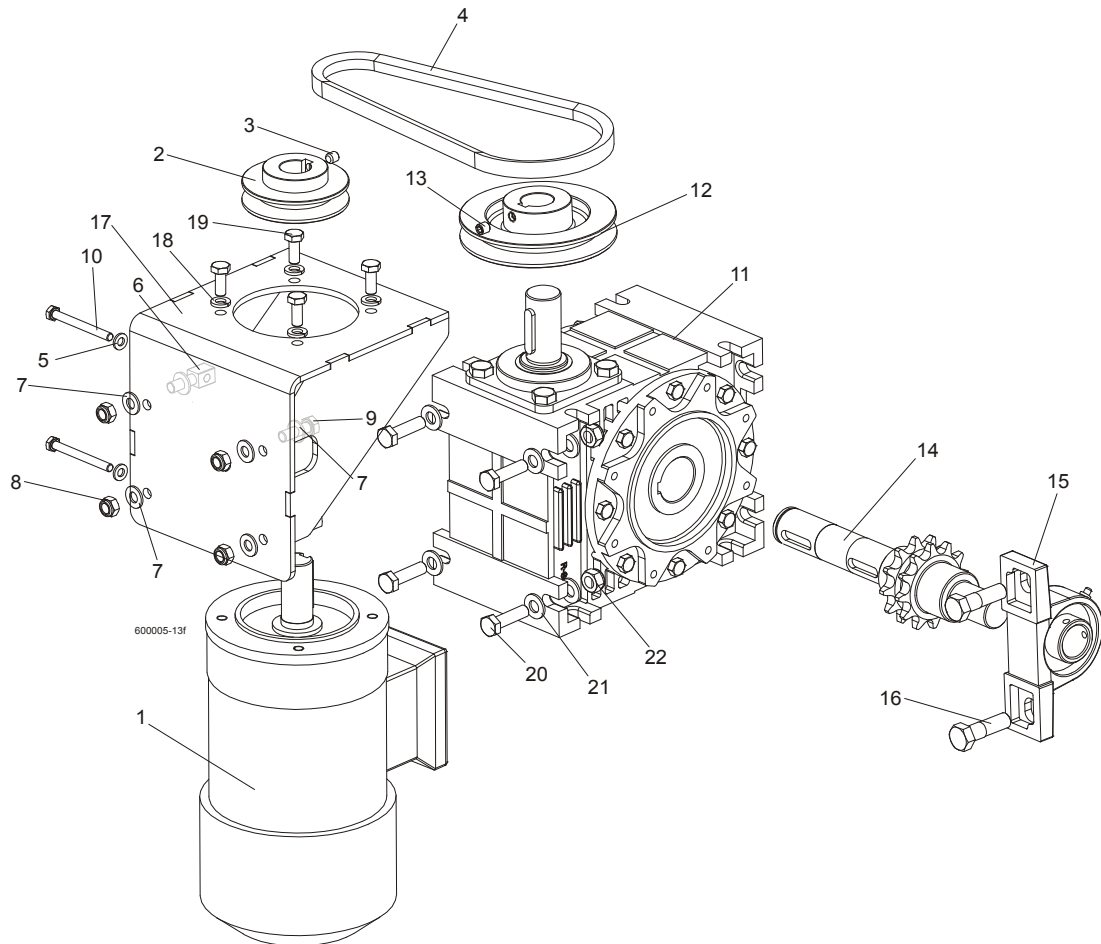

REF	DESCRIPTION (◆ Indicates Parts Available In Assemblies Only)	PART #	QTY.	
	MOTOR W/MOUNT BRACKET, AC UP/DOWN	090493	1	
1	AC Motor, 2 gear STKg90 6/4L2 IMB14/162	086530	1	
2	Pulley, AC Motor Painted	090497-1	1	
3	Screw, M8x8-33H Hex Socket Set Flat Point Zinc	F81014-1	1	
4	V-Belt, HA-670	091328	1	
5	Washer, 6.4 Zinc Flat	F81053-1	2	

6	Bolt, Special - Zinc Plated	088962-1	2	
7	Washer, 8.4 Zinc Flat	F81054-1	8	
8	Nut, M8-8-B Hex Nylon Zinc Lock	F81032-2	4	
9	Bolt, M8X25-8.8-B Hex Head Full Thread Zinc	F81002-5	2	
10	Bolt, M6x60-8.8 Hex Head Full Thread Zinc	F81001-9	2	
	GEAR BOX ASSEMBLY, UP/DOWN DRIVE	091310	1	
11	Gear Box, R80/64/WBS/D1,N+S,V5	097701	1	
12	Pulley, Up/Down Gear Painted	091308-1	1	
13	Screw, M8x8-33H Hex Socket Set Flat Point Zinc	F81014-1	1	
14	Output Shaft W/Sprocket, Up/Down Drive	512183	1	
15	Bearing Assembly, UCP205 CX	088468	1	
16	Bolt, M12 x 40-8.8 Hex Head Zinc	F81004-1	1	
17	BRACKET, AC UP/DOWN MOTOR MOUNT PTD	090494-1	1	
18	WASHER 8.2 SPLIT LOCK ZINC	F81054-4	4	
19	BOLT, M8 X 20-8.8-B HEX HEAD FULL THREAD ZINC	F81002-4	4	
20	BOLT M10x35-8.8 HEX HEAD FULL THREAD ZINC	F81003-17	4	
21	WASHER 10,5Fe/Zn5, SPECIAL	F81055-4	8	
22	NUT,M10-8-B NYLON HEX ZINC LOCK	F81033-1	4	

6.5 Safety Switches

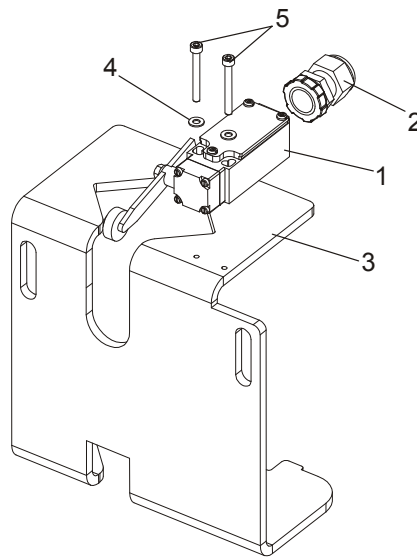

600045B

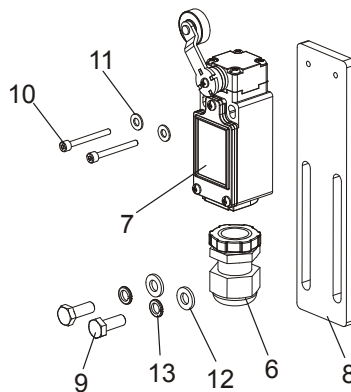

REF	DESCRIPTION (◆ Indicates Parts Available In Assemblies Only)	PART #	QTY.
1	SWITCH , GLCB01A2B SAFETY	086469	2
2	STUFFING-BOX, SKINTOP PG 13,5	086524	2
3	SUPPORT, POWER CORD BRACKET	090460-1 ¹	1
4	WASHER 4,3 FE/ZN5 PN-M/82005	F81051-2	4
5	SCREW, M4x35-8.8 HEX SOCKET HEAD CAP ZINC	F81011-34	4
	KIT, LT70 SAFETY SWITCH LOWER	505711	1
6	STUFFING-BOX, SKINTOP PG 13,5	086524	1
7	LIMIT SWITCH, GLCB01A1B	100931	1
8	BAR, SAFETY SWITCH MOUNT	505125-1	1
9	BOLT, M6 x 16 8.8 Fe/Zn5 PN-M/82105	F81001-15	2
10	BOLT, M3X30 8.8 SOCKET HEAD ZINC	F81011-38	2
11	WASHER 4,3 FE/ZN5 PN-M/82005	F81051-2	2
12	WASHER, M6, FLAT,ZINC	F81053-1	2
13	WASHER, M6 SPLIT LOCK ZINC	F81053-3	2

¹ LT70DC version only.

SECTION 7 FEED SYSTEM & TRACK ROLLERS

7.1 Upper Track Rollers And Wipers

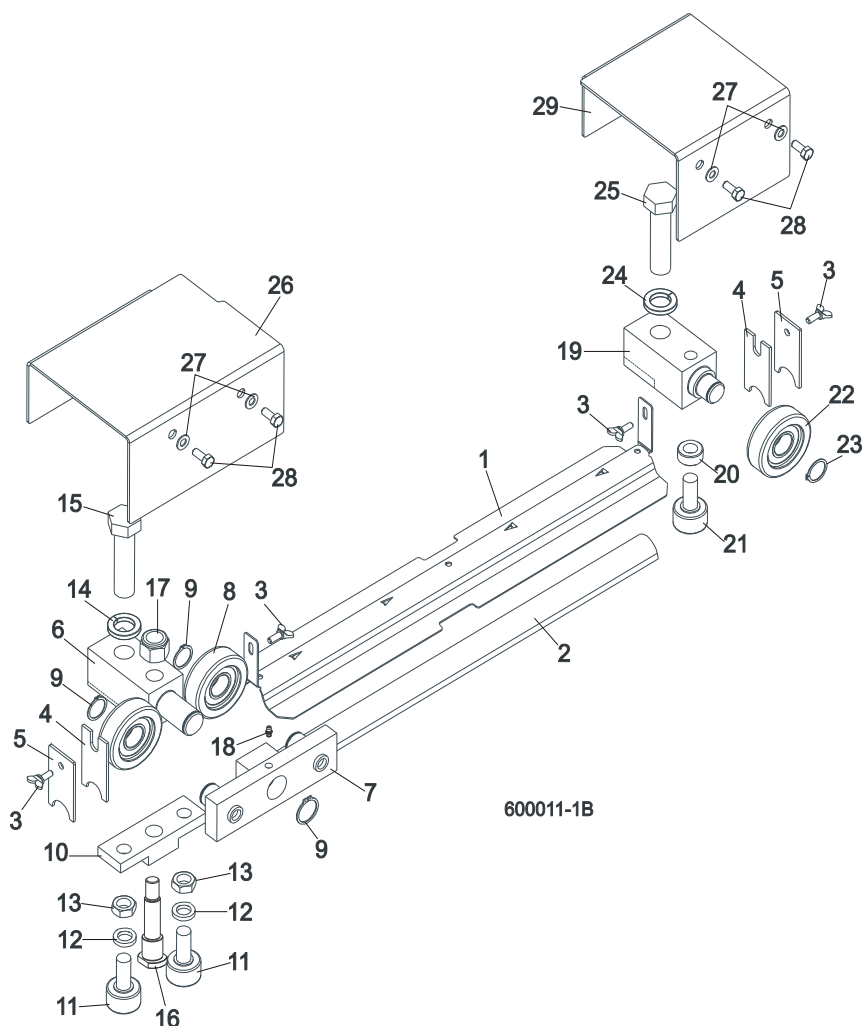

REF	DESCRIPTION (◆ Indicates Parts Available In Assemblies Only)	PART #	QTY.
1	COVER, LT40/70 MIDDLE TRACK - SERVICE	092868-S	1
	Cover, LT40/70 Middle Track Ptd	092868-1	1
2	Strip, 3/16 X 2 X 23 Felt	S09915	1
3	SCREW, M6X20 DIN 316 WING	F81001-58	4
4	WIPER, TOP RAIL	M04113	2
5	PLATE, TRACK WIPER	088559-1	2
	ROLLER ASSEMBLY, UPPER TANDEM TRACK	088530	1
6	Block, Tandem Roller Mount	088532	1
7	Block Assembly, Tandem Roller	088535	1
8	Bearing, CBK-468 Rolling	088433	2
9	Ring, Z30 Spring Retaining	F81090-23	2
10	Block, Cam Follower Mount	088520	1
11	Bearing, Cam Follower (McGill)	012797	2
12	Washer, 16.3 Split Zinc Lock	F81058-2	2
13	Nut, 5/8"-18 Zinc	F05010-11	2

14	Washer, Z24.5 Split Zinc Lock	F81061-4	1	
15	Bolt, M24 x 2 x 90-8.8 Hex Head Full Thread Zinc	F81009-2	1	
16	Pin, Cam Follower Mount	088531	1	
17	Nut, M16-8 Hex Nylon Zinc Lock	F81036-2	1	
18	Fitting, M6 Straight Grease	086280	1	
	ROLLER ASSEMBLY, REAR UPPER TRACK	088529	1	
19	Block, Rear Upper Roller Mount	088528	1	
20	Spacer, Cam Follower	088536	1	
21	Bearing, Cam Follower (McGill)	012797	1	
22	Roller, CBK-468	088433	1	
23	Ring, Z30 Spring Retaining	F81090-23	1	
24	Washer, Z24.5 Split Zinc Lock	F81061-4	1	
25	Bolt, M24x2x90-8.8 Hex Head Full Thread Zinc	F81009-2	1	
26	COVER, TANDEM ROLLER	088526-1	1	
27	WASHER, 6.4 ZINC FLAT	F81053-1	4	
28	BOLT, M6X16 8.8 HEX HEAD FULL THREAD ZINC	F81001-15	4	
29	COVER, REAR UPPER ROLLER	088527-1	1	

7.2 Power Feed Assembly

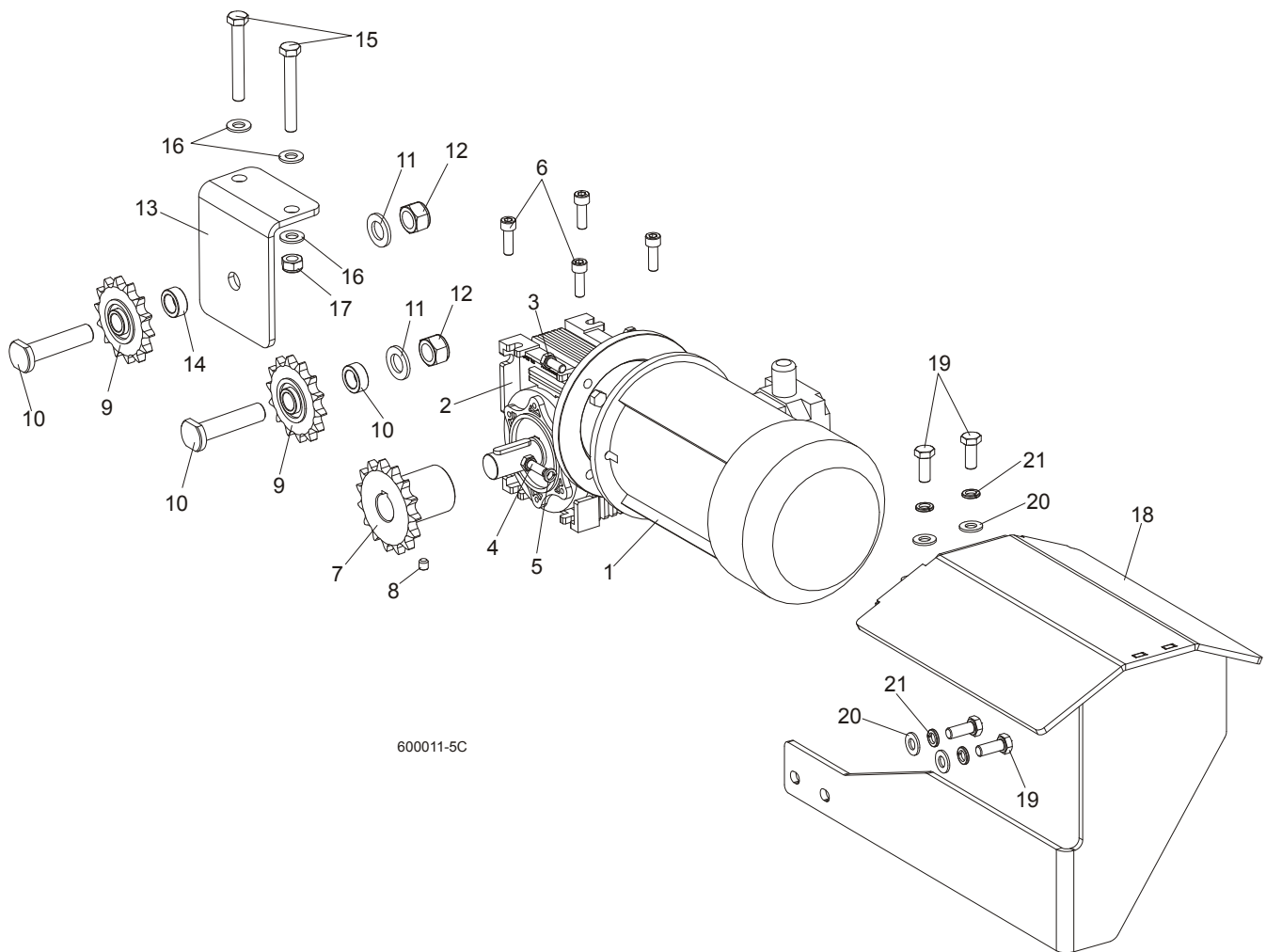

REF	DESCRIPTION (◆ Indicates Parts Available In Assemblies Only)	PART #	QTY.
	MOTOREDUCER MR-50/7.5/1.1-1380/K3/B8	100936	1
1	Electric motor 1,1kW AC	090104	1
2	MOTOREDUCER, MR-50/7.5/DO SILN/K3,N+S,B8	100935	1
3	BOLT, M8X20MM, HEX HEAD,GR 5.8 ZINC	F81002-4	2
4	BOLT,M8X25-8.8-B HEX HEAD FULL THREAD	F81002-5	2
5	WASHER 8,2 FE/ZN9	F81054-4	2
6	SCREW, M8x25 -8.8 HEX SOCKET HEAD CAP	F81002-21	4
7	SPROCKET, 10B Z15 ZINC	088541-1	1
8	SCREW, M8x8-33H HEX SOCKET SET FLAT POINT ZINC	F81014-1	2
9	SPROCKET, KSR 16.L0.10.10.14.08 W/BEARING	088867	2
10	PIN, ZINC SPROCKET MOUNT	088994-1	2
11	WASHER, 17 ZINC FLAT	F81058-1	2
12	NUT, M16-8 HEX NYLON ZINC LOCK	F81036-2	2
13	BRACKET, POWER FEED SPROCKET MOUNT	088507-1	1
14	SPACER, POWER FEED SPROCKET	088550-1	1

15	BOLT, M10x75-8.8 HEX HEAD ZINC	F81003-15	2	
16	WASHER, 10.5 ZINC FLAT	F81055-1	4	
17	NUT, M10-8-B HEX NYLON ZINC LOCK	F81033-1	2	
	GUARD, LT70AC POWER FEED MOTOR COMPLETE	504651	1	
18	GUARD, LT70AC POWER FEED MOTOR	504652-1	1	
19	BOLT, M10-1.5X25MM HH GR8.8	F81003-11	4	
20	WASHER, 10.5 ZINC FLAT	F81055-1	4	
21	WASHER,10.2 SPLIT LOCK ZINC	F81055-2	4	

7.3 Feed Chain/Stop

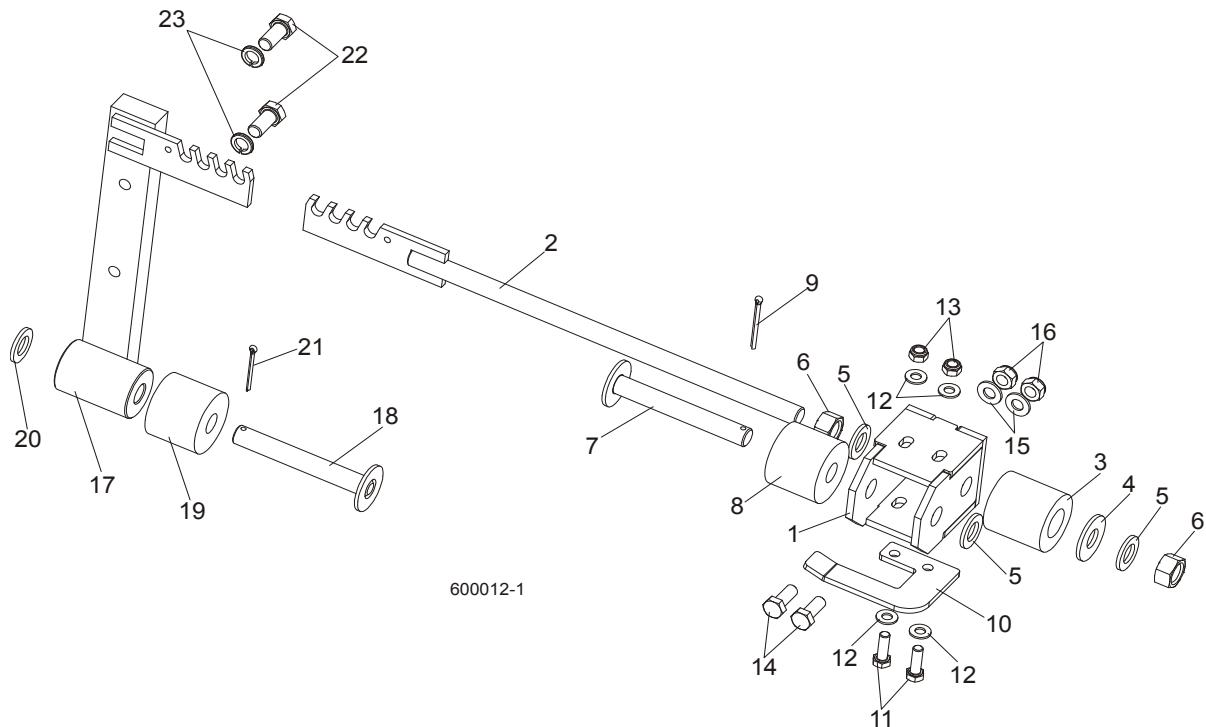

REF	DESCRIPTION (◆ Indicates Parts Available In Assemblies Only)	PART #	QTY.
1	MOUNT WELDMENT, FRONT CARRIAGE STOP	089365-1	1
2	TENSIONER WELDMENT, POWER FEED CHAIN	089364-1	1
3	SPRING, LT15 BLADE TENSIONER	014828	1
4	WASHER, ZINC SPECIAL	089360-1	1
5	WASHER, 17 ZINC FLAT	F81058-1	3
6	NUT, M16-5.8 ZINC HEX	F81036-1	2
7	PIN, RUBBER CARRIAGE STOP	089361-1	1
8	BUSHING, RUBBER STOP	P12165	1
9	PIN, S-Zn 4x25 COTTER	F81043-2	1
10	BRACKET, LIMIT SWITCH	086473-1	1
11	BOLT, M8X25-8.8-B HEX HEAD FULL THREAD ZINC	F81002-5	2
12	WASHER, 8.4 ZINC FLAT	F81054-1	4
13	NUT, M8-8-B HEX NYLON ZINC LOCK	F81032-2	2
14	BOLT, M10X25 8.8 HEX HEAD FULL THREAD	F81003-31	2
15	WASHER, 10.5 ZINC FLAT	F81055-1	2
16	NUT, M10-8-B HEX NYLON ZINC LOCK	F81033-1	2
	STOP ASSEMBLY, REAR POWER FEED	089362	1
17	Stop Weldment, Rear Power Feed	088346-1	1
18	Pin, Rubber Carriage Stop	089361-1	1
19	Bushing, Rubber Stop	P12165	1
20	Washer, 17 Zinc Flat	F81058-1	1
21	Pin, S-Zn 4x25 Cotter	F81043-2	1
22	BOLT, M12X25-8.8 HEX HEAD FULL THREAD ZINC	F81004-31	2
23	WASHER, 13 ZINC FLAT	F81056-1	2

CHAIN, 10B-1 POWER FEED	088670	1	
LINK, 10B-1PZ MASTER	088671	2	

7.4 Lower Track Rollers

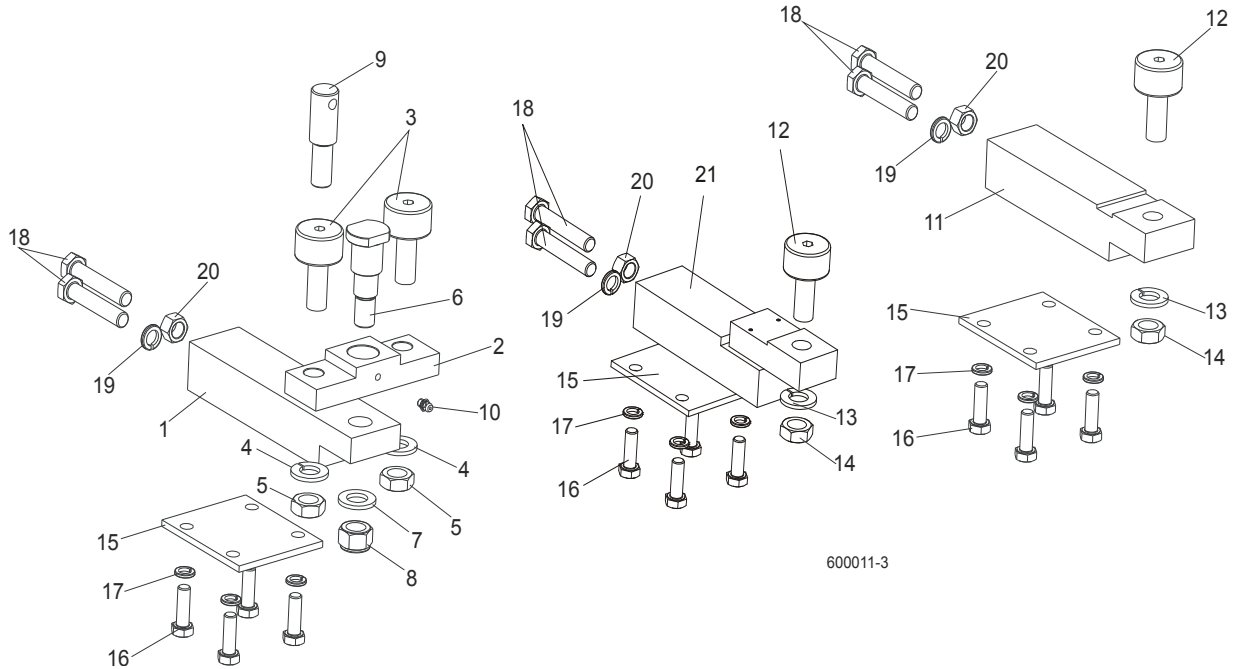

600011-3

REF	DESCRIPTION (◆ Indicates Parts Available In Assemblies Only)	PART #	QTY.
	BLOCK ASSEMBLY, VERTICAL MAST ALIGNMENT DOUBLE	088523	1
1	Block, Vertical Mast Alignment Double	088517	1
2	Block, Cam Follower Mount	088520	1
3	Bearing, Cam Follower (McGill)	012797	2
4	Washer, 16.3 Split Zinc Lock	F81058-2	2
5	Nut, 5/8"-18 Zinc	F05010-11	2
6	Pin, Cam Follower Mount	088521	1
7	Washer, 17 Zinc Flat	F81058-1	1
8	Nut, M16-8 Hex Nylon Zinc Lock	F81036-2	1
9	Pin, Safety Lock	088519	1
10	Fitting, M6 Straight Grease	086280	1
	BLOCK ASSEMBLY, VERTICAL MAST ALIGNMENT SINGLE	088524	1
11	Block, Vertical Mast Alignment Single	088518	1
12	Bearing, Cam Follower (McGill)	012797	1
13	Washer, 16.3 Split Zinc Lock	F81058-2	1
14	Nut, 5/8"-18 Zinc	F05010-11	1
15	PLATE, LOWER TRACK ROLLER RETAINER	088516	3
16	BOLT, M10X30-5.8 HEX HEAD FULL THREAD ZINC	F81003-2	12
17	WASHER, 10.2 SPLIT ZINC LOCK	F81055-2	12
18	BOLT, M12X1.25X65-8.8 HEX HEAD FULL THREAD ZINC	F81004-40	6
19	WASHER, Z12.2 SPLIT ZINC LOCK	F81056-2	3
20	NUT, M12X1.25-8 ZINC HEX	F81034-8	3
21	BLOCK WELDMENT, LOWER TRACK ROLLER MOUNT	091425	1

SECTION 8 BED FRAME ASSEMBLY

8.1 Bed Section

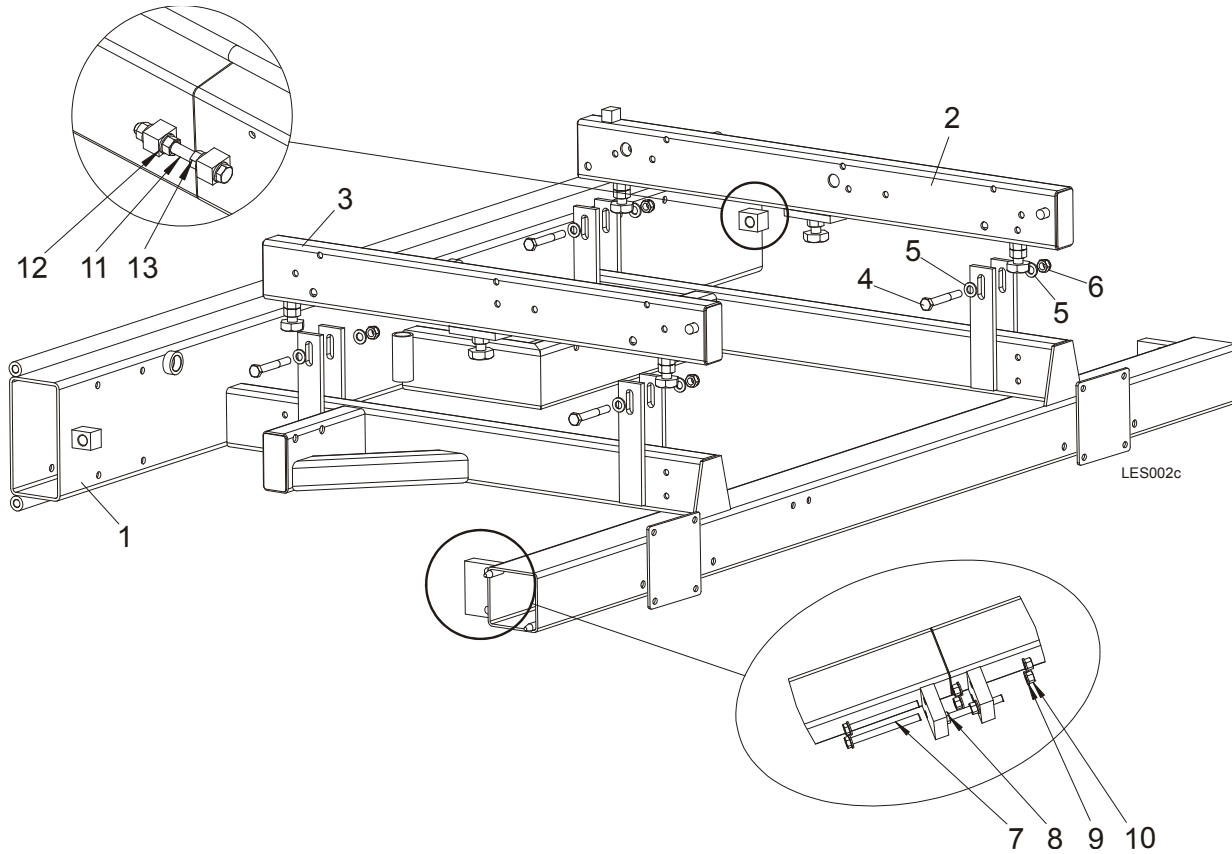

REF	DESCRIPTION (◆ Indicates Parts Available In Assemblies Only)	PART #	QTY.
1	BED SECTION, LES COMPLETE	099710-1	1
2	Tube Wldmt, Bed, LT80 Long	089385	1
3	Tube Wldmt, Bed, LT80 Short	089386	1
4	Bolt, M12 x 90-8.8 Hex Head Zinc	F81004-2	4
5	Washer, 13 SAE Flat	F81056-1	8
6	Nut, M12-8 Hex Nylon Zinc Lock	F81034-2	4
7	BOLT, M12X130-8.8 HEX HEAD ZINC	F81004-55	2
8	BOLT, M12X100-8.8 HEX HEAD ZINC	F81004-45	1
9	WASHER, 13 SAE FLAT	F81056-1	7
10	NUT, M10-8-B HEX NYLON ZINC LOCK	F81033-1	5
11	BOLT, M16X160-8.8 HEX HEAD ZINC	F81006-23	1
12	WASHER, 17 FLAT ZINC	F81058-1	4
13	NUT, M16-5.8 HEX ZINC	F81036-1	3

8.2 Bed Section, Additional

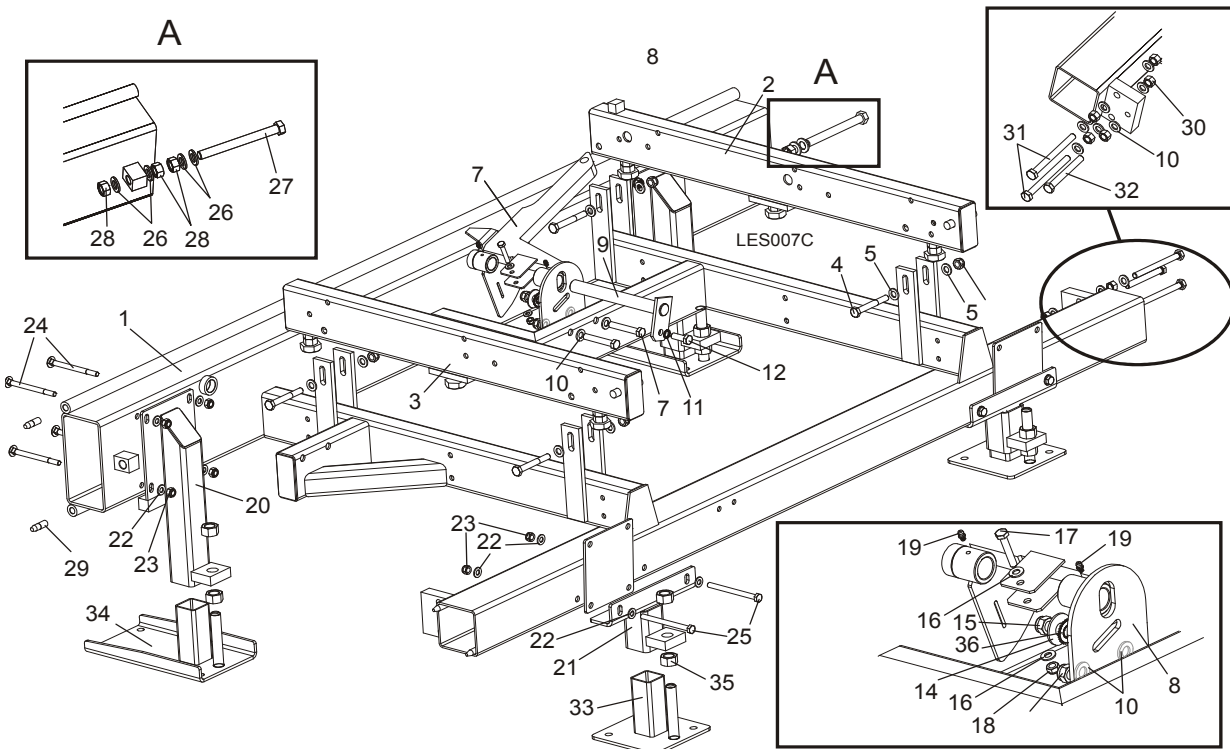

REF.	DESCRIPTION (◆ Indicates Parts Available In Assemblies Only)	PART #	QTY.
	BED SECTION, LES ADDITIONAL	101061-S	1
1	BED FRAME SECTION,	099710-1	1
2	Tube Wldmt, Bed, LT80 Long	089385	1
3	Tube Wldmt, Bed, LT80 Short	089386	1
4	Bolt, M12 x 90-8.8 Hex Head Zinc	F81004-2	4
5	Washer, 13 Flat Zinc	F81056-1	8
6	Nut, M12-8 Hex Nylon Zinc Lock	F81034-2	4
7	SUPPORT, PTD SIDE W/GUARD	099785-1	1
8	PLATE, LOG SIDE SUPPORT MOUNT PTD	091591-1	1
9	PIN, SIDE SUPPORT ZINC-PLATED	091549-1	1
10	WASHER,13 FLAT ZINC	F81056-1	11
11	WASHER, SERRATED BN781 M12/13	F81056-16	1
12	BOLT, M12 X 35-8.8-FE/ZN5 HEX HEAD FULL	F81004-24	1
13	BOLT, M12 X 75-8.8 HEX HEAD ZINC	F81004-21	2
14	WASHER, 15 FLAT SPECIAL ZINC-PLATED	F81057-3	1
15	NUT, M12-8 HEX NYLON ZINC LOCK	F81034-2	3
16	WASHER, 8.4 FLAT ZINC	F81054-1	2
17	BOLT, M8 X 45 - 8.8 HEX HEAD FULL THREAD ZINC	F81002-14	1
18	NUT, M8-8-B HEX NYLON ZINC LOCK	F81032-2	1
19	FITTING, 3/16X3/16 STRAIGHT GREASE	P04107	2
20	SUPPORT, HIGH LES	100559-1	2
21	SUPPORT, LOW LES	100553-1	2
22	WASHER, 10.5 FLAT ZINC	F81055-1	16

8 Bed Frame Assembly

Bed Extension

23	NUT, M10-8-B NYLON HEX ZINC LOCK	F81033-1	12	
24	BOLT, M10X120 8.8 FE/ZN5	F81003-33	8	
25	BOLT, M10x125-8.8 HEX HEAD ZINC	F81003-18	4	
26	WASHER, 17 FLAT ZINC	F81058-1	4	
27	BOLT, M16x160-8.8 HEX HEAD FULL THREAD ZINC	F81006-23	1	
28	NUT, M16-5.8 HEX ZINC	F81036-1	3	
29	PIN, SPECIAL	090675	2	
30	NUT, M12-8-B ZINC HEX	F81034-1	5	
31	BOLT, M12X130-8.8 HEX HEAD FULL THREAD ZINC	F81004-55	2	
32	BOLT, M12X100 8.8 HEX HEAD FULL THREAD ZINC	F81004-45	1	
33	FOOT, LES TABLE LEG	099281-1	2	
34	FOOT WIDE LES	500775-1	2	
35	NUT, M20-8 HEX ZINC	F81037-1	8	
36	WASHER, SERRATED BN783 M12/12.3/30.3	F81056-17	1	

8.3 Bed Extension

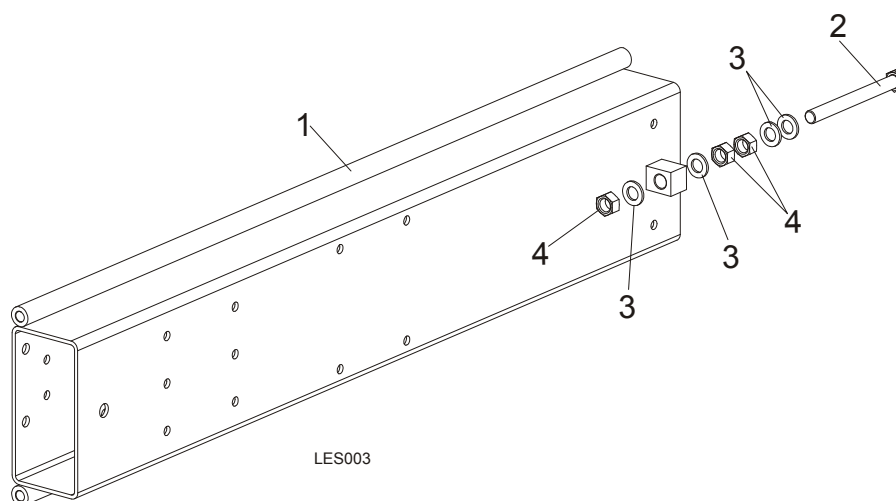

REF.	DESCRIPTION (◆ Indicates Parts Available In Assemblies Only)	PART #	QTY.	
	BED EXTENSION, LES COMPLETE	099729	1	
1	Bed Extension, LES	099728-1	1	
2	Bolt, M16x160-8.8 Hex Head Zinc	F81006-23	1	
3	Washer, 17 Zinc Flat	F81058-1	4	
4	Nut, M16-5.8 Hex Zinc	F81036-1	3	

8.4 Stationary Leg Kit

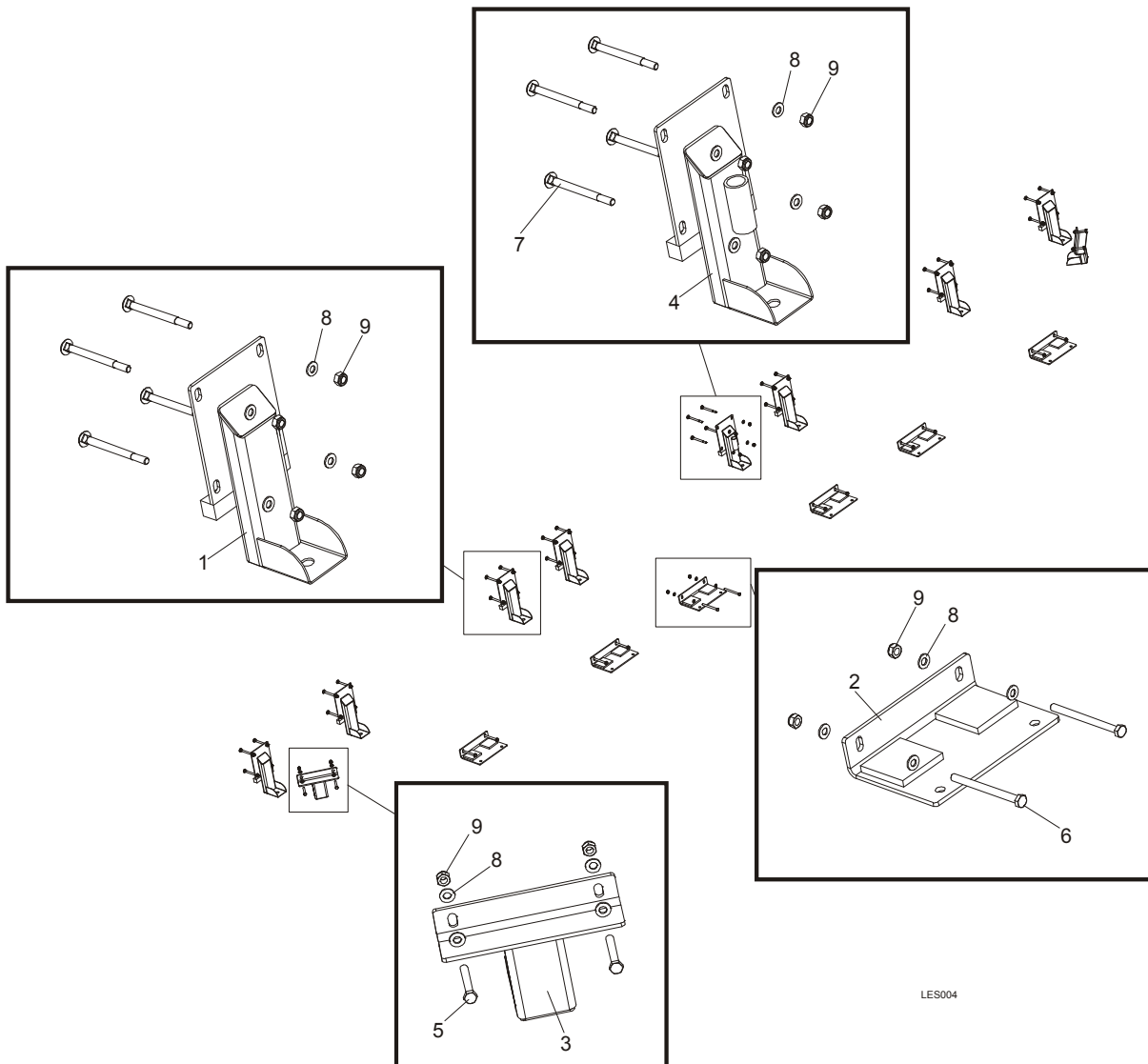

REF.	DESCRIPTION (◆ Indicates Parts Available In Assemblies Only)	PART #	QTY.
	KIT, LES STATIONARY LEG (LT20B2)	500802	1
	KIT, LES STATIONARY LEG (LT20B3)	100864	1
1	Leg, LES High	100536-1	5/7
2	Leg, LES Low	100550-1	6
3	Leg, LES Side	100868-1	2
4	Leg, LES High w/Bushing	101186-1	1
5	Bolt, M10X75-8.8 Hex Head Zinc	F81003-15	4
6	Bolt, M10x125-8.8 Hex Head Zinc	F81003-18	8/12
7	Bolt, M10X120 8.8 Carriage Head Zinc	F81003-33	24/32
8	Washer, 10.5 Flat Zinc	F81055-1	52/64
9	Nut, M10-8-B Hex Nylon Zinc Lock	F81033-1	36/48

8 Bed Frame Assembly

Outrigger Leg Kit

8.5 Outrigger Leg Kit

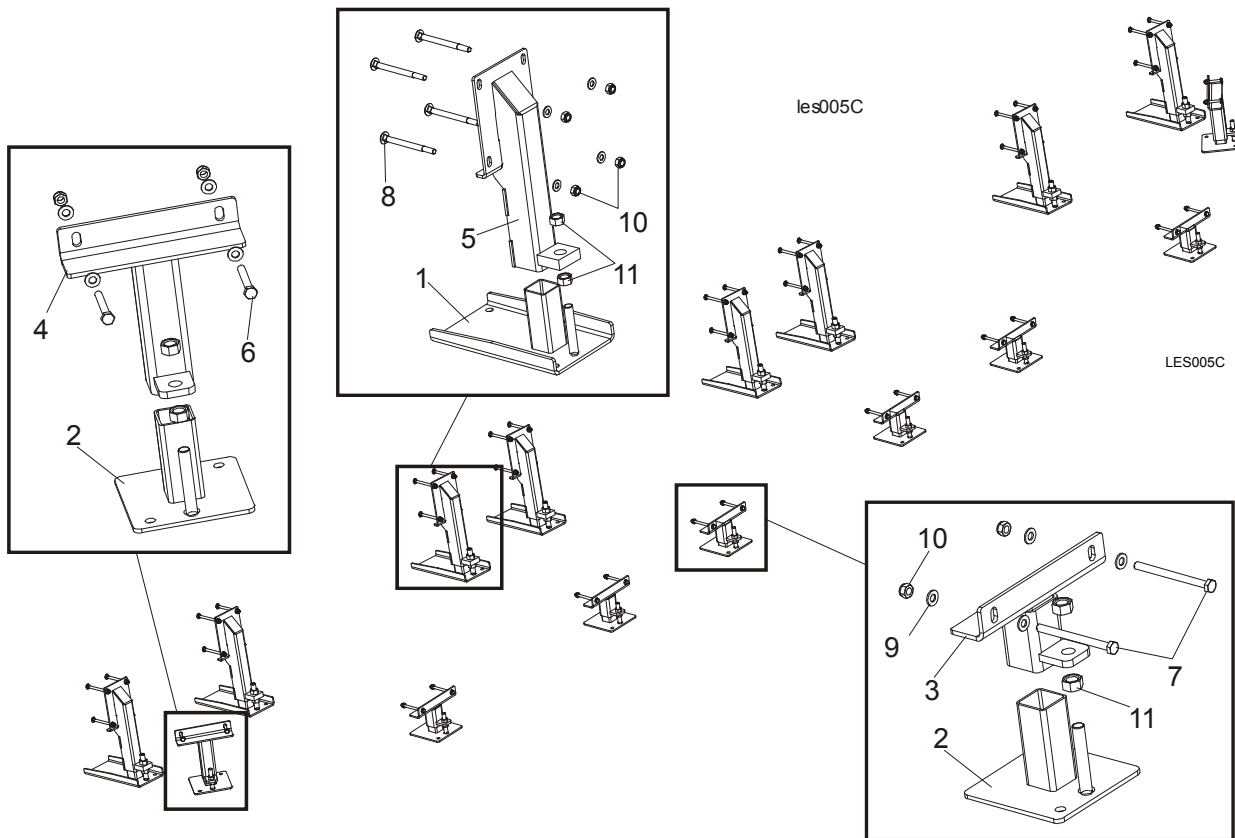

REF.	DESCRIPTION (◆ Indicates Parts Available In Assemblies Only)	PART #	QTY.
	KIT, LES OUTRIGGER LEG (LT20B2)	500803	1
	KIT, LES OUTRIGGER LEG (LT20B3)	100865	1
1	Foot, LES Wide	500775-1	6/8
2	Foot, LES Table Leg	099281-1	6/8
3	Leg, LES Low	100553-1	4/6
4	Leg, LES Side	100554-1	2
5	Leg, LES High	100559-1	6/8
6	Bolt, M10X75-8.8 Hex Head Zinc	F81003-15	4
7	Bolt, M10x125-8.8 Hex Head Zinc	F81003-18	8/12
8	Bolt, M10X120 8.8 Carriage Head Zinc	F81003-33	24/32
9	Washer, 10.5 Flat Zinc	F81055-1	48/64
10	Nut, M10-8-B Hex Nylon Zinc Lock	F81033-1	40/48
11	Nut, M16-5.8 Hex Zinc	F81036-1	32

8.6 Outrigger Leg Kit High - LES B3

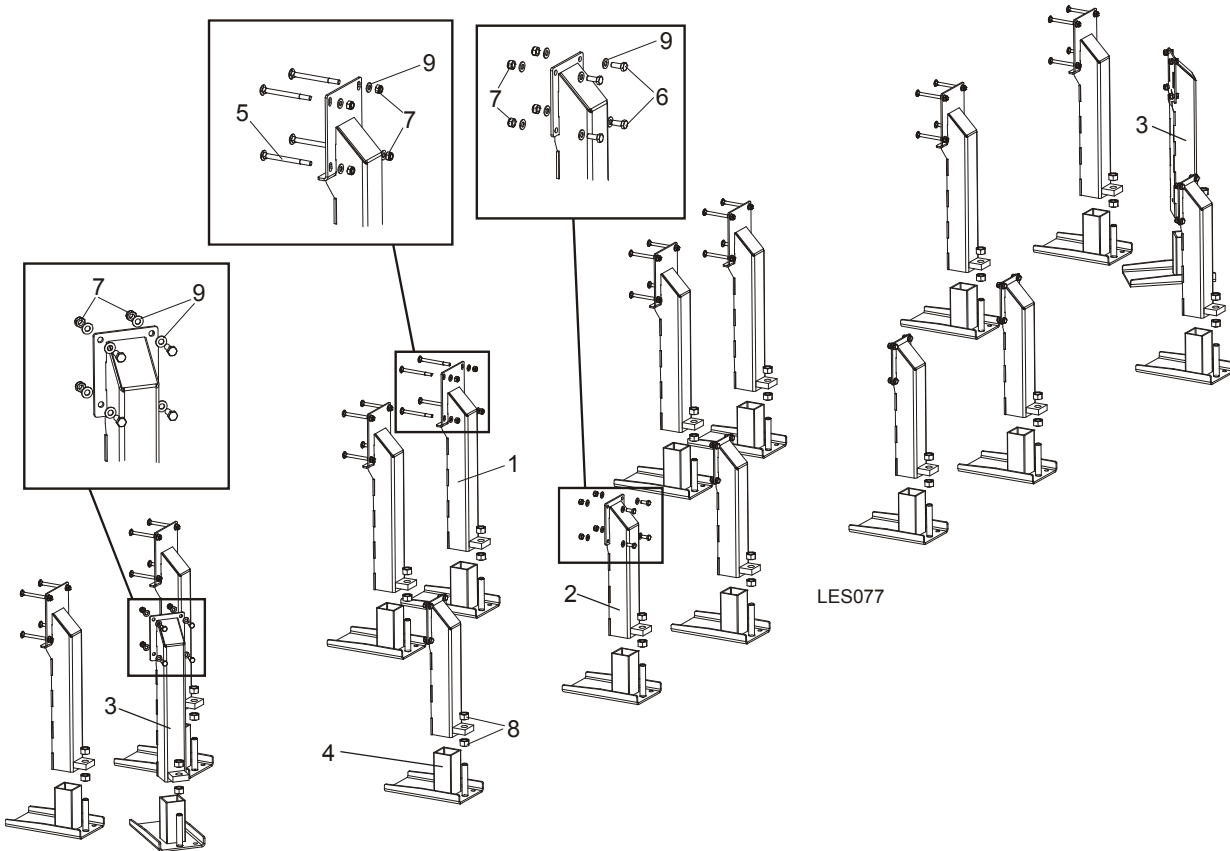

REF.	DESCRIPTION (◆ Indicates Parts Available In Assemblies Only)	PART #	QTY.
	KIT, LES OUTRIGGER LEG HIGH- LES B3	508436	1
1	Leg, LES High Main Tube	507620-1	8
2	Leg, LES Side LT40B/RPA	508435-1	6
3	Leg, LES Side	507715-1	2
4	Foot, LES Wide	501084-1	16
5	Bolt, M10X120 8.8 Carriage Head Zinc	F81003-33	32
6	Bolt, M10x25-8.8 Hex Head Full Thread Zinc	F81003-11	32
7	Nut, M10-8-B Hex Nylon Zinc Lock	F81033-1	64
8	Nut, M20-8 Hex Zinc	F81037-1	32
9	Washer, 10.5 Flat Zinc	F81055-1	96

8.7 Log Side Support Assembly

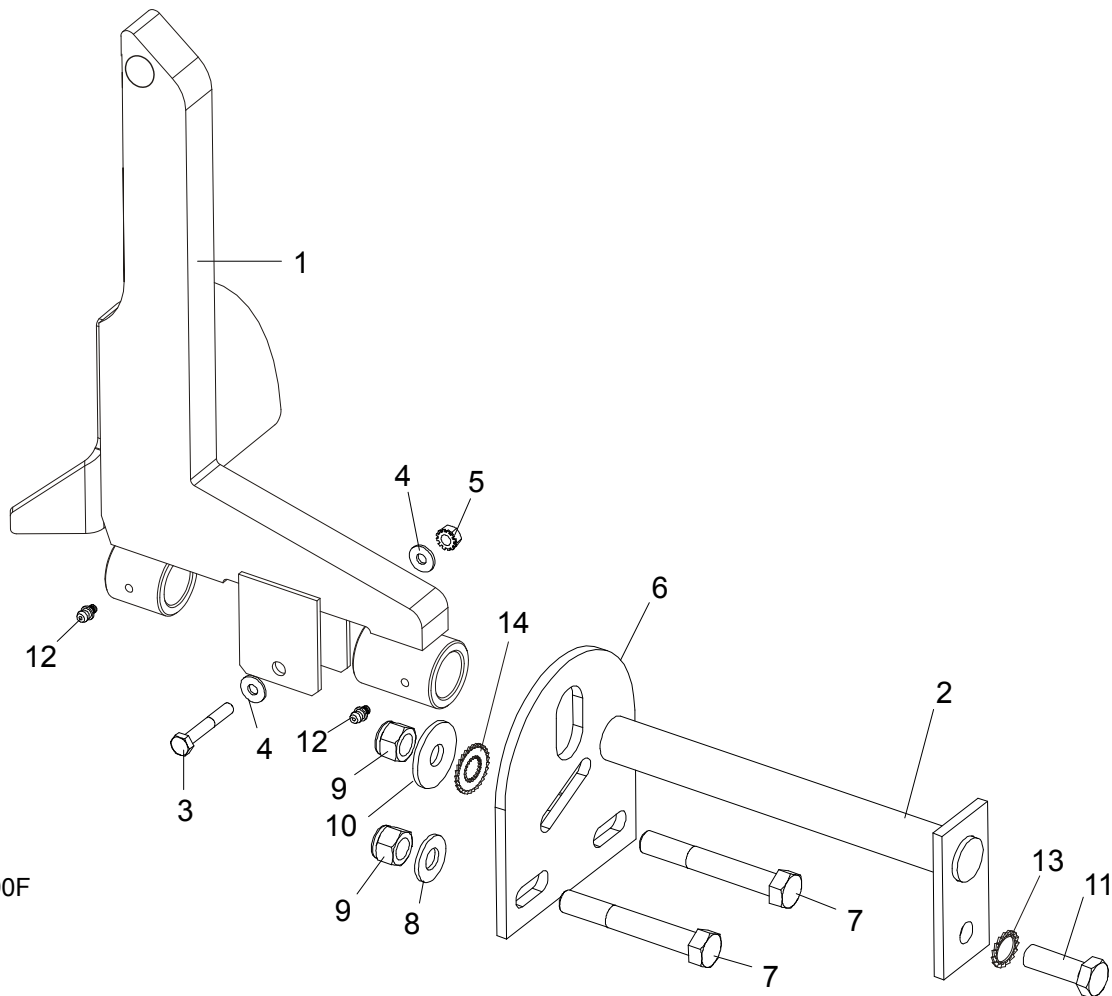

Sm0190F

REF.	DESCRIPTION (◆ Indicates Parts Available In Assemblies Only)	PART #	QTY.
	SUPPORT KIT, MANUAL LOG SIDE	092686	1
	LOG SIDE SUPPORT - LT20B	500960	3
1	SUPPORT, LOG SIDE W/GUARD	099785-1	1
2	Pin, Log Side Support Pivot	091549-1	1
3	Bolt, M8x45-8.8 Hex Head Full Thread Zinc	F81002-14	1
4	Washer, 8.4 Flat	F81054-1	2
5	Nut, M8-8-B Self Locking	F81032-2	1
6	Plate, Log Side Support End	091591-1	1
7	Bolt, M12 x 75-8.8 Hex Head	F81004-21	2
8	Washer, 13 Flat	F81056-1	2
9	Nut, M12-8 Hex Nylon Lock	F81034-2	3
10	Washer, 15 Flat Special Zinc-Plated	F81057-3	1
11	Bolt, M12 x 35-8.8 Hex Head	F81004-24	1
12	FITTING, 3/16" GREASE	P04107	2
13	WASHER, SPECIAL BOSART/2S, BN781 M12/13	F81056-16	1
14	WASHER, SPECIAL BOSART/2S M12/12,3/30,3	F81056-17	1

8.8 Front & Rear Tubes

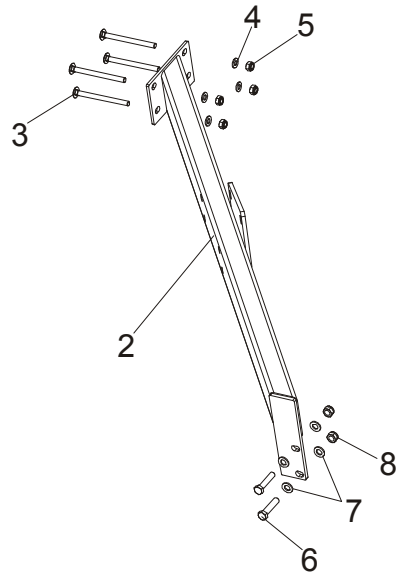

LES012a

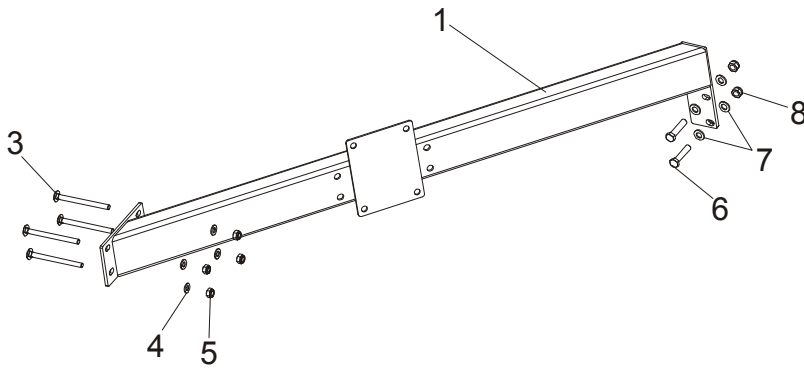

REF.	DESCRIPTION (◆ Indicates Parts Available In Assemblies Only)	PART #	QTY.
1	TUBE, LES BED FRONT	100551-1	1
2	TUBE, LES BED REAR	100545-1	1
3	BOLT, M10X125 CARRIAGE	F81003-34	8
4	WASHER, 10.5 ZINC FLAT	F81055-1	8
5	NUT, M10-8-B HEX NYLON ZINC LOCK	F81033-1	8
6	BOLT, M12X55-8.8 HEX HEAD ZINC	F81004-12	4
7	WASHER, 13 FLAT ZINC	F81056-1	8
8	NUT, M12-8 HEX NYLON ZINC LOCK	F81034-2	4

8 Bed Frame Assembly

Bumpers

8.9 Bumpers

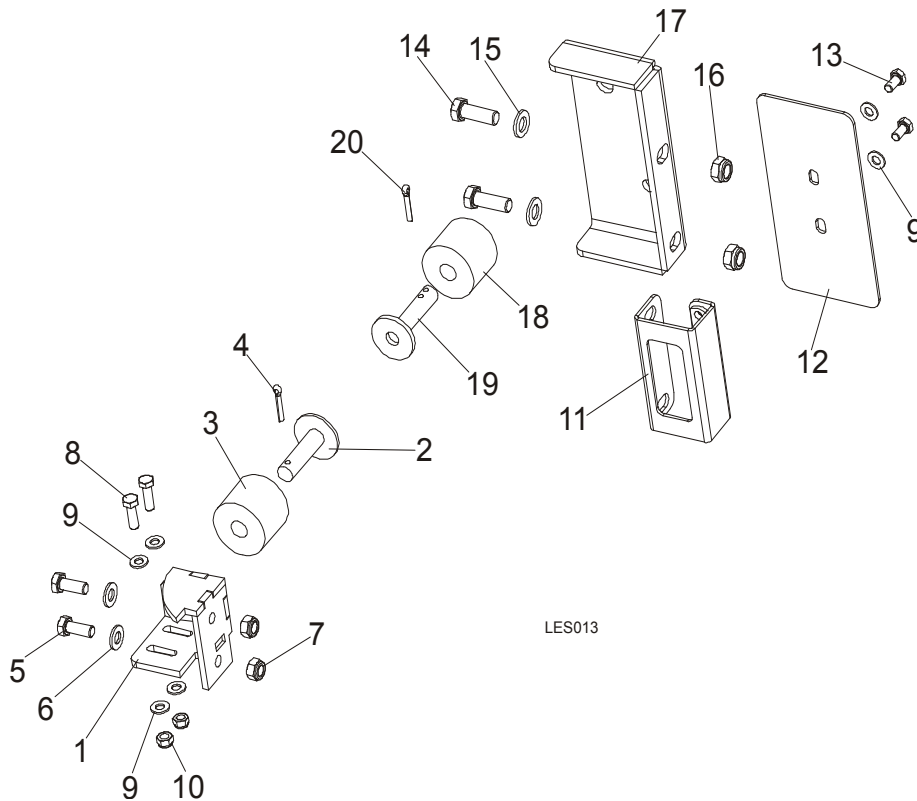

REF.	DESCRIPTION (◆ Indicates Parts Available In Assemblies Only)	PART #	QTY.
1	MOUNT WELDMENT, FRONT CARRIAGE STOP	089712-1	1
2	MOUNT WELDMENT, CARRIAGE STOP PTD	086182-1	1
3	BUSHING, 11/16x2 1/8x1 3/4 RUBBER	P12165	1
4	PIN, 3/16 X 1 COTTER	F05012-21	1
5	BOLT, M10X25-8.8 HEX HEAD FULL THREAD ZINC	F81003-11	2
6	WASHER, 10.5 ZINC FLAT	F81055-1	2
7	NUT, M10-8-B HEX NYLON ZINC LOCK	F81033-1	2
8	BOLT, M8x25-8.8-B HEX HEAD FULL THREAD ZINC	F81002-5	2
9	WASHER, 8.4 FLAT ZINC	F81054-1	2
10	NUT, M8-8-B HEX NYLON ZINC LOCK	F81032-2	2
11	BRACKET WELDMENT, REAR MAIN TUBE COVER	087105-1	1
12	COVER, MAIN TUBE REAR	015023	1
13	BOLT, M8x16-8.8-B HEX HEAD FULL THREAD ZINC	F81002-20	2
14	BOLT, M12 X 35-8.8-FE/ZN5 HEX HEAD FULL THREAD	F81004-24	2
15	WASHER, 13 FLAT ZINC	F81056-1	2
16	NUT, M12-8 HEX NYLON ZINC LOCK	F81034-2	2
	BUMPER, REAR COMPLETE	091828	1
17	BRACKET, BUMPER REAR	091829-1	1
18	BUSHING, 11/16X2 1/8X1 3/4 RUBBER	P12165	1
19	STOP, (PTD) CARRIAGE	W09293	1
20	PIN, 3/16 X 1 COTTER	F05012-21	1

8.10 Remote Equipment Option

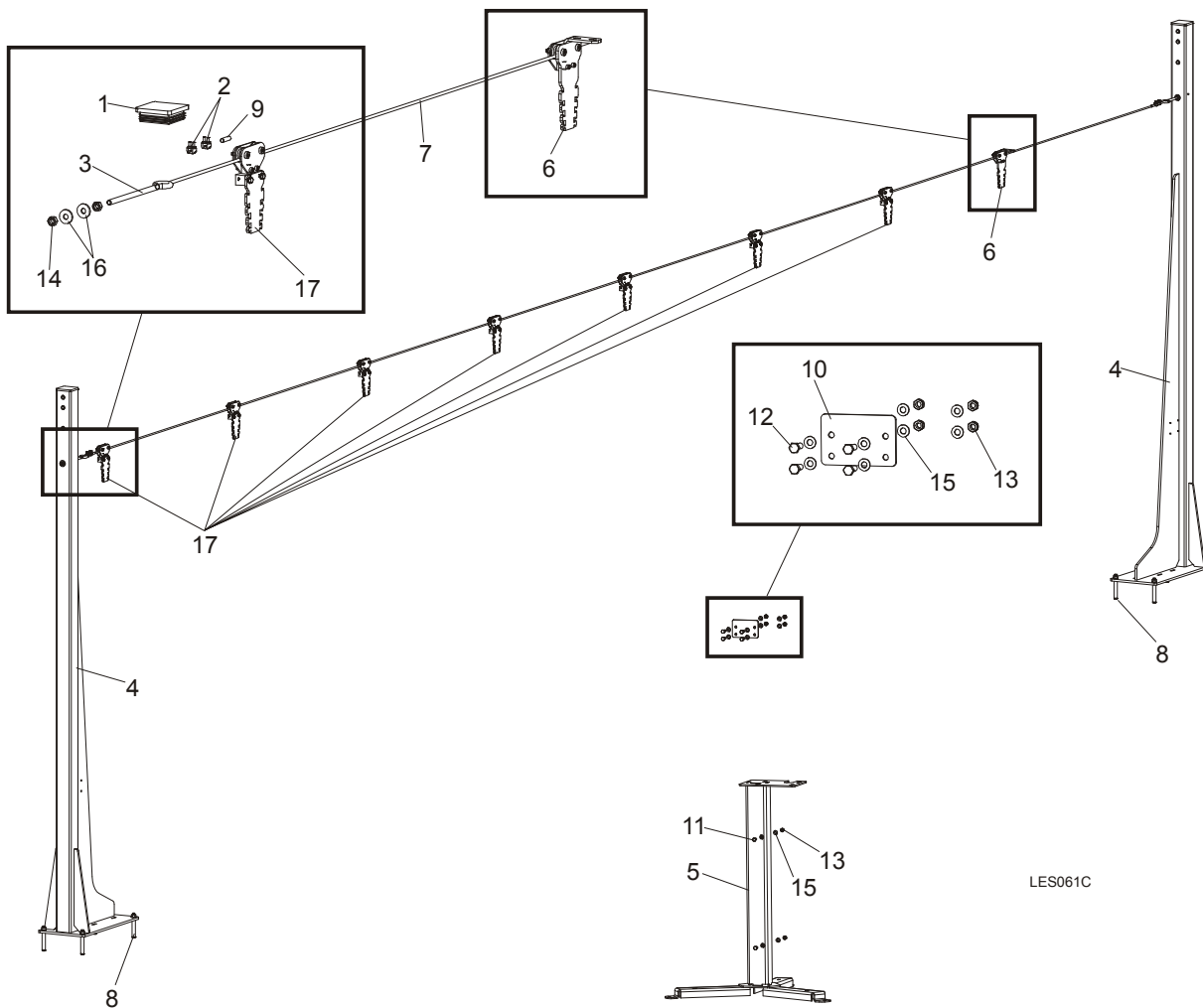

LES061C

REF.	DESCRIPTION (◆ Indicates Parts Available In Assemblies Only)	PART #	QTY.
	EQUIPMENT, LT20B REMOTE COMPLETE	501649	1
1	CAP, EDGER FRAME	089644	2
2	CLAMP, LT20 STRING	091614	4
3	TENSIONER, ZINC-PLATED	500846-1	2
4	COLUMN, LT20B LINE GUIDE	503600-1	2
5	STAND, LT20B CONTROL BOX	501651-1	1
6	PULLEY, STATIONARY	504264	1
7	CABLE, 6MM (11,5 M) STEEL	504279	1
8	PIN, LT 16X120	501877	8
9	POINTER, 6MM STEEL CABLE	504280-1	2
10	CAP, LT20B REMOTE CONTROL BOX	501879-1	1
11	BOLT, M8X20-5.8 HEX HEAD FULL THREAD ZINC	F81002-1	2
12	BOLT, M8x25-8.8-B HEX HEAD FULL THREAD ZINC	F81002-5	4
13	NUT, M8-8-B HEX NYLON ZINC LOCK	F81032-2	6
14	NUT, M10-8-B HEX ZINC	F81033-3	4
15	WASHER, 8.4 FLAT ZINC	F81054-1	12

8 Bed Frame Assembly

Bed Frame Decals

16	WASHER,10.5 ZINC FLAT SPECIAL	F81055-6	4	
17	PULLEY	504114	7	

8.11 Bed Frame Decals

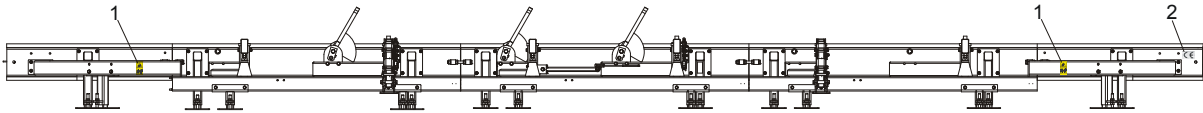

LES014

REF.	DESCRIPTION (◆ Indicates Parts Available In Assemblies Only)	PART #	QTY.	
	PICTOGRAPHIC DECAL KIT, LES	101215	1	
	PICTOGRAPHIC DECAL KIT, LT20AC See Section 4.5	099509	1	
1	DECAL, KEEP AWAY DANGER, PICTOGRAM	099221	2	
2	DECAL, CE CERTIFIED SAWMILL (SMALL)	P85070	1	

8.12 Saw Head Transportation Holder, LT70B

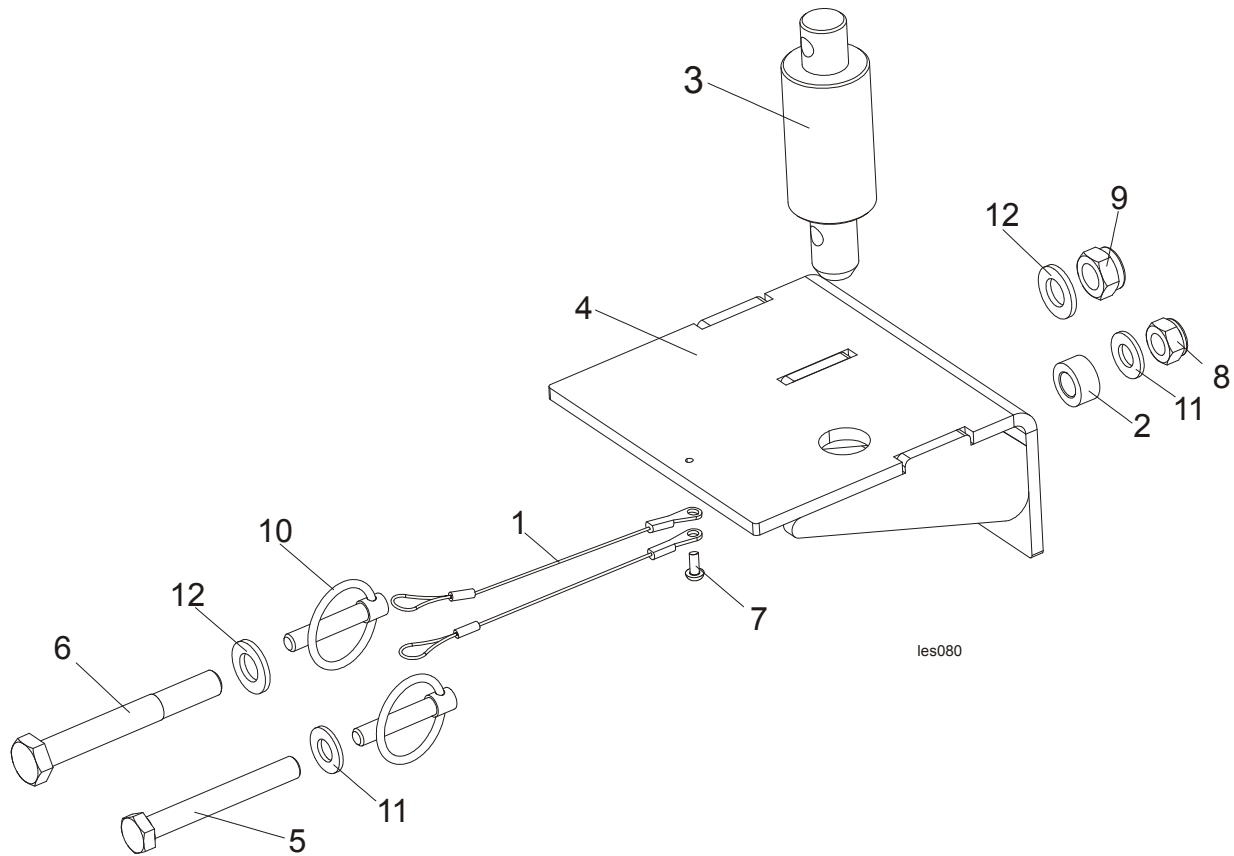

REF	DESCRIPTION (◆ Indicates Parts Available In Assemblies Only)	PART #	QTY.
	HOLDER, SAW HEAD TRANSPORTATION LT70B-COMPLETE	509277	1
1	LANYARD, 3/64x6	016030	2
2	BUSHING, SPACER ZINC-PLATED	090936-1	1
3	PIN, SAW HEAD REST LT20 PTD.	097935-1	1
4	HOLDER, TRANSPORTATION LT70B WLDMT/PTD	509278-1	1
5	BOLT, HEX HEAD M10x80-8.8-ZINC	F81003-50	1
6	BOLT, M12X95 8.8 HEX HEAD ZINC	F81004-29	1
7	SCREW, M4X12-5.8-B-CROSS RECESSED PAN HEAD ZINC	F81011-43	1
8	NUT, M10 HEX NYLON ZINC LOCK	F81033-1	1
9	NUT, M12 8 HEX NYLON ZINC LOCK	F81034-2	1
10	PIN, 8 BN914 (Bossard 1364650) LOCK	F81046-2	2
11	WASHER, 10,5 FLAT ZINC	F81055-1	2
12	WASHER, 13MM FLAT ZINC	F81056-1	2

SECTION 9 LOG CLAMP, LOADING RAMP & TOE BOARD

9.1 Log Clamp, LES

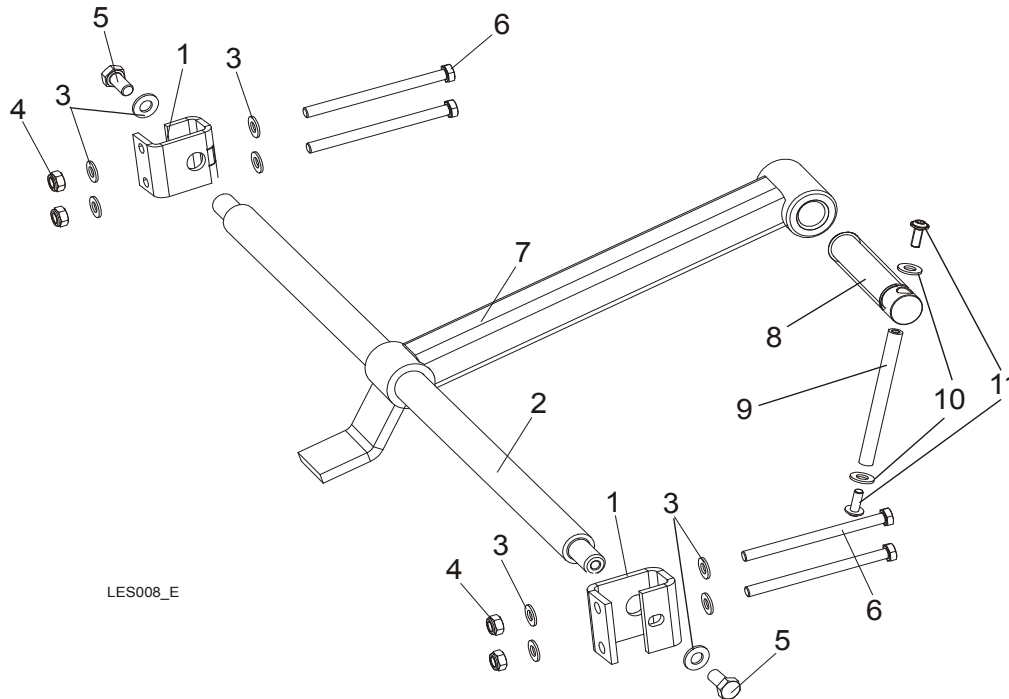

LES008_E

REF.	DESCRIPTION (◆ Indicates Parts Available In Assemblies Only)	PART #	QTY.
	CLAMP-LES	510230	1
1	BRACKET, LOG CLAMP MOUNT ZINC-PL.	500338-1	2
2	ROD, MAIN CLAMP	100643	1
3	WASHER, 10.5 FLAT ZINC	F81055-1	10
4	NUT, M10-8-B HEX NYLON ZINC LOCK	F81033-1	4
5	BOLT, M10X20-5.8 HEX HEAD FULL THREAD ZINC	F81003-1	2
6	BOLT, M10 X 80-8.8 HEX HEAD ZINC	F81003-50	4
7	CLAMP ARM	508453-1	1
	CLAMP BOLT - COMPLETE	507563	1
8	CLAMP BOLT	507463	1
	ROD - COMPLETE	511924	1
9	ROD - ZINC-PLATED	511923-1	1
10	WASHER, 8.4 FLAT ZINC	F81054-1	2
11	BOLT, M6x16 BN 11252 "BOSSARD"	F81001-24	2

9.2 Loading Ramp

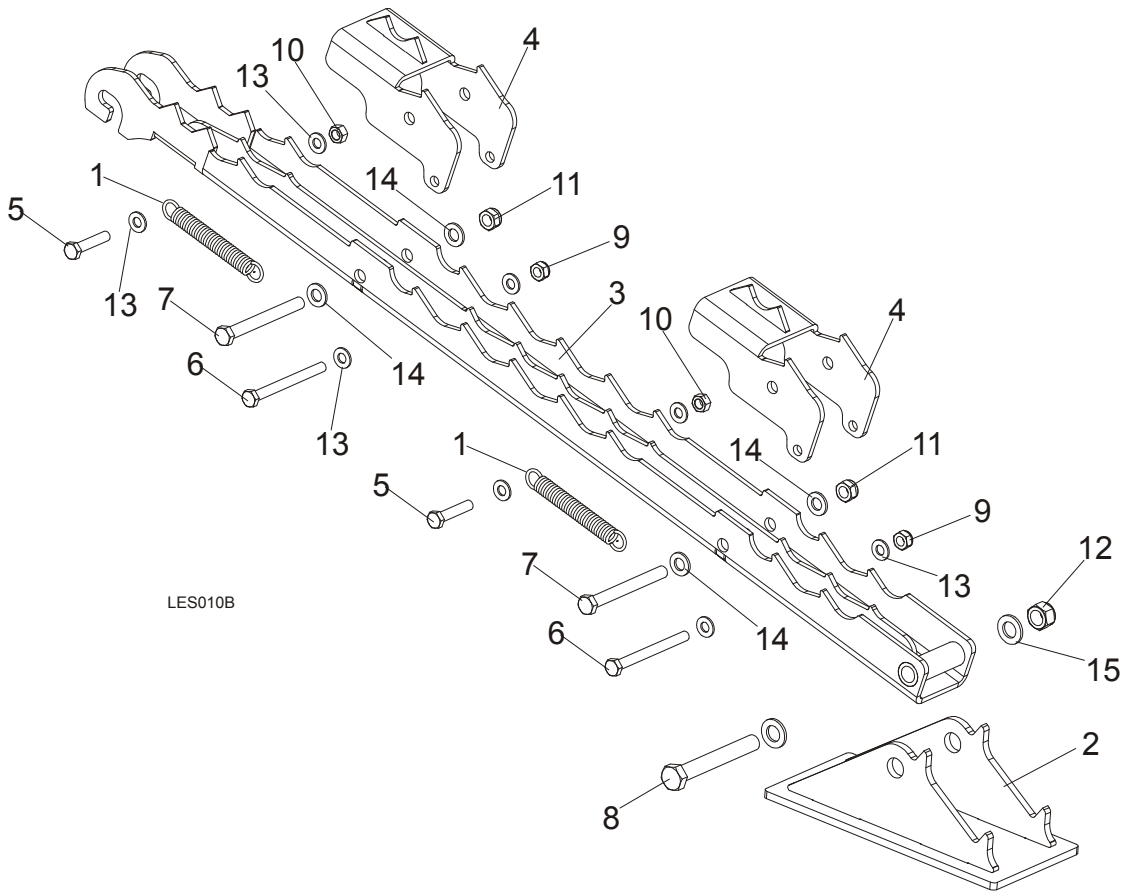

REF.	DESCRIPTION (◆ Indicates Parts Available In Assemblies Only)	PART #	QTY.
	LOADING RAMP, LES	500795	1
1	Spring, $\phi 1.9 \times \phi 14.2 \times 104$	091865	2
2	Foot, LES Loading Ramp	500788-1	1
3	Loading Ramp, LES	500790-1	1
4	Plate, LES Log w/Teeth	500799-1	2
5	Bolt, M10X50-8.8 Hex Head Full Thread Zinc	F81003-4	2
6	Bolt, M10x110 8.8 Hex Head Zinc	F81003-43	2
7	Bolt, M12X115-8.8 Hex Head Zinc	F81004-33	2
8	Bolt, ISO 24014 M16 X 120 8.8 A2E	F81006-25	1
9	Nut, M10-8-B Hex Nylon Zinc Lock	F81033-1	2
10	Nut, M10-8-B Hex Zinc	F81033-3	2
11	Nut, M12-8 Hex Nylon Zinc Lock	F81034-2	2
12	Nut, M16-8 Hex Nylon Zinc Lock	F81036-2	1
13	Washer, 10.5 Zinc Flat	F81055-1	8
14	Washer, 13 Flat Zinc	F81056-1	4
15	Washer, 17 Flat Zinc	F81058-1	2

9.3 Manual Toe Board

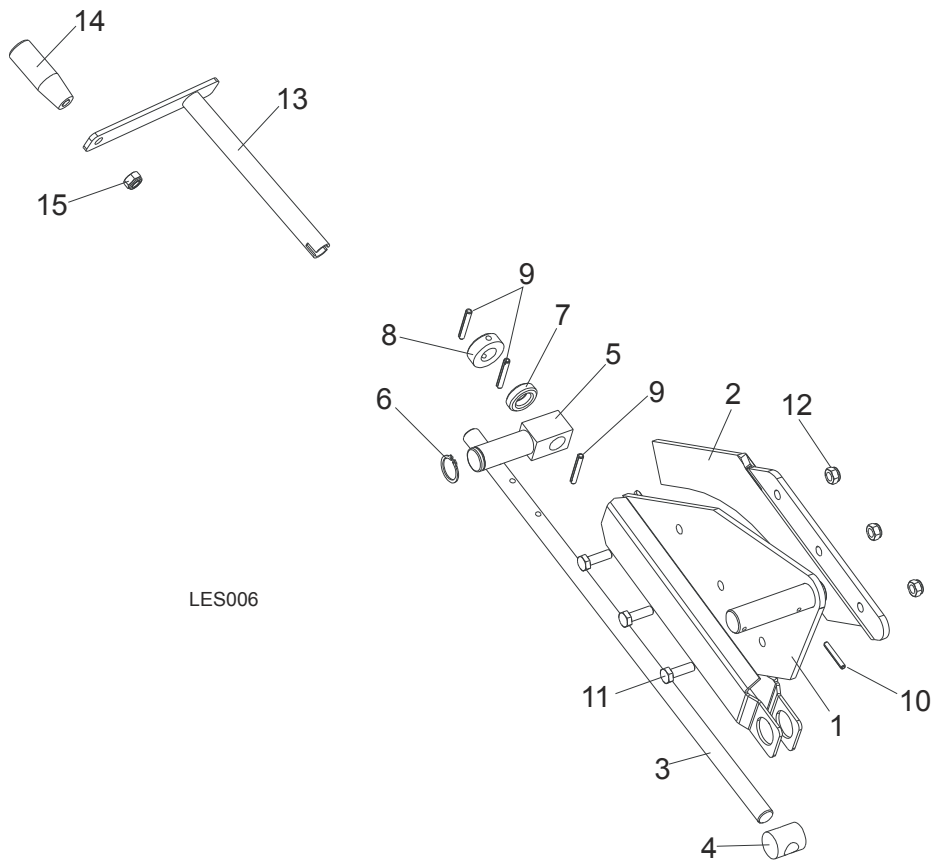

REF.	DESCRIPTION (◆ Indicates Parts Available In Assemblies Only)	PART #	QTY.
	TOE BOARD KIT, MANUAL REAR	094928	2
1	Plate Weldment, Manual Toe Board Rear	094926-1	1
2	Extension, Manual Toe Board Plate (II)	095202-1	1
3	Shaft, Manual Toe Board	090344-1	2
4	Nut, Special Threaded	090017	2
5	Pivot, Manual Toe Board Shaft (I)	094931-1	2
6	Ring, Z 22 Outside Retaining	F81090-24	2
7	Bearing, 5/8" Thrust	P04214	2
8	Collar, 16	F81039-6	2
9	Pin, 5x35-N-C PN-EN ISO 8752 Roll	F81044-9	6
10	Pin, 4x30 Zinc Roll	F81044-7	2
11	Bolt, M8 x 25-8.8-B Hex Head Full Thread Zinc	F81002-5	6
12	Nut, M8-8-B Hex Nylon Zinc Lock	F81032-2	6
	CRANK ASSEMBLY, MANUAL TOE BOARD	500600	1
13	Crank, Manual Toe Board	500599-1	1
14	Knob, Plastic Crank Handle	086338	1
15	Nut, M10-8-B Nylon Hex Zinc Lock	F81033-1	1

9.4 H1/H2/H3 Control Assemblies - Options

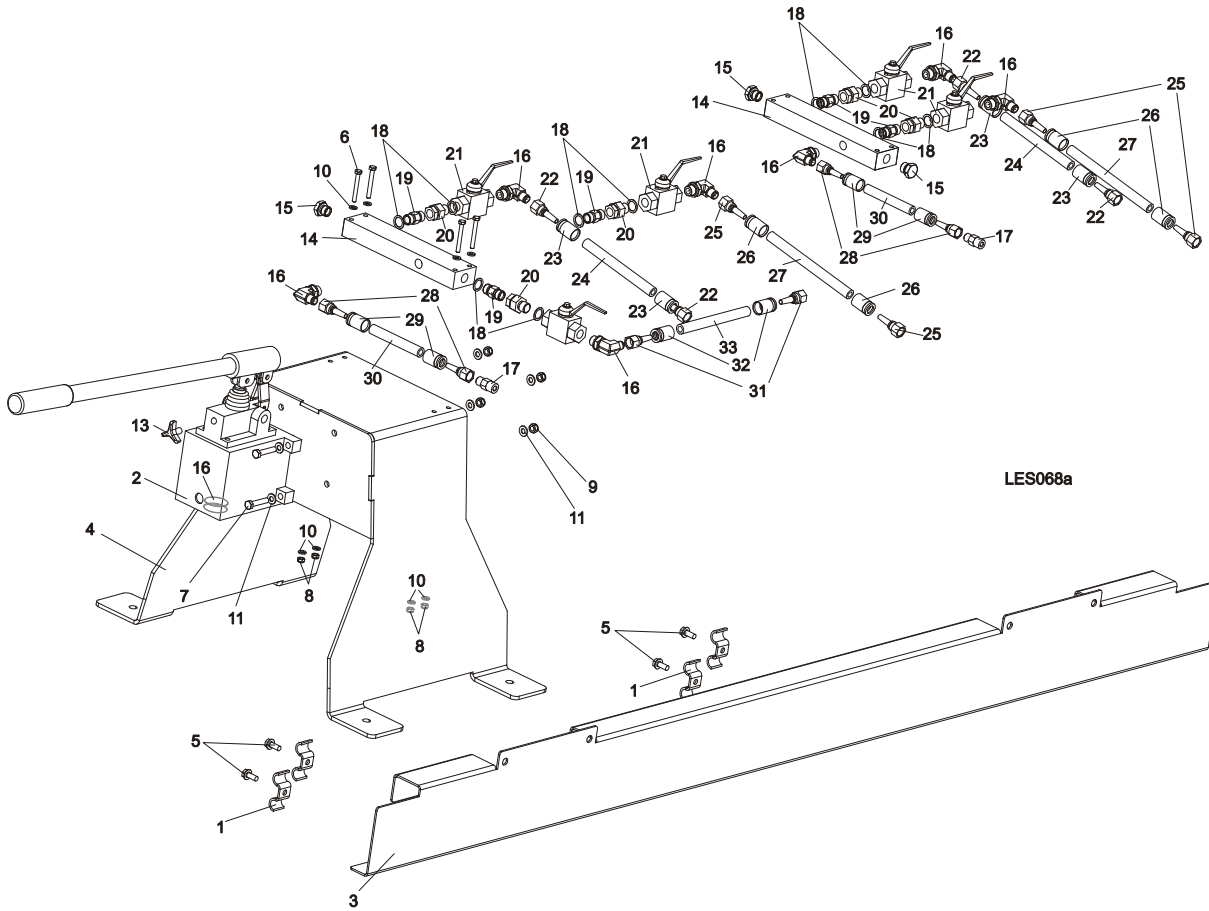

REF.	DESCRIPTION (◆ Indicates Parts Available In Assemblies Only)	PART #	QTY.
	H1 CONTROL ASSEMBLY-LES	504360	1
1	CLAMP, 3/8" HOSE	016041	8
2	PUMP, PMS12/TNK1 HAND W/RELIEF VALVE	505630	1
3	CHANNEL, HYDRAULIC HOSE GUIDE	502419-1	3
4	BRACKET, PUMP & VALVE MOUNT	502543-1	1
5	SCREW, 5/16-18 x 3/4 SELF-TAPPING	F05015-30	8
6	BOLT, M6x50-8.8 HEX HEAD ZINC	F81001-62	4
7	BOLT, M8x40-8.8 HEX HEAD FULL THREAD ZINC	F81002-15	4
8	NUT, M6-8-B HEX NYLON ZINC LOCK	F81031-2	4
9	NUT, M8-8-B HEX NYLON ZINC LOCK	F81032-2	4
10	WASHER, 6.4 FLAT ZINC	F81053-1	8
11	WASHER, 8.4 FLAT ZINC	F81054-1	8
12	MAGNET, MW.38x12/N38 NEODYMIUM	500022	1
13	VALVE, LES HAND PUMP RELIEF - COMPLETE	083712	1
14	BLOCK, 4-WAY HYDRAULIC VALVE	502540-1	1
15	CAP, 3/8 BSPP (G3/8)	502544	2
	VALVE, H1 LES HYDRAULIC	504361	1
16	FITTING, 3/8" BSP-9/16" JIC ELBOW	096335	3
17	FITTING, G3/8-9/16-18JIC HAND PUMP	091842	1
18	WASHING, 16x22 SEALING COPPER	502420	4

9 Log Clamp, Loading Ramp & Toe Board

H1/H2/H3 Control Assemblies - Options

19	FITTING, 3/8 BSP GZ STRAIGHT	503617	2	
20	FITTING, 3/8" BSP-GZ/GW 600 106 06 REDUCER	503616	2	
21	VALVE, 3/8 " G BALL	502056	2	
	PHD 2T3/8X4.200 W9/16UNF-W9/16UNF	502413	1	
22	FITTING, JIC 9/16-18	085900	2	
23	CRIMP SOCKET, 3/8" HYDRAULIC HOSE	085901	2	
24	HOSE, 3/8" (C/S-20MPa)P/N8106-6-06 HYDRAULIC	R02132	(4.2m)	
	PHD 2T3/8X4.200 W9/16UNF-W9/16UNF	502414	1	
25	FITTING, JIC 9/16-18	085900	2	
26	CRIMP SOCKET, 3/8" HYDRAULIC HOSE	085901	2	
27	HOSE, 3/8" (C/S-20MPa)P/N8106-6-06 HYDRAULIC	R02132	(7.2m)	
	PHD 2T3/8X4.200 W9/16UNF-W9/16UNF	502416	1	
28	FITTING, JIC 9/16-18	085900	2	
29	CRIMP SOCKET, 3/8" HYDRAULIC HOSE	085901	2	
30	HOSE, 3/8" (C/S-20MPa)P/N8106-6-06 HYDRAULIC	R02132	(0.58m)	
	H2/H3-LES CONTROL ASSEMBLY	502055	1	
1	CLAMP, 3/8" HOSE	016041	8	
2	PUMP, PMS12/TNK1 HAND W/RELIEF VALVE	505630	1	
3	CHANNEL, HYDRAULIC HOSE GUIDE	502419-1	3	
4	BRACKET, PUMP & VALVE MOUNT	502543-1	1	
5	SCREW, 5/16-18 x 3/4 SELF-TAPPING	F05015-30	8	
6	BOLT, M6x50-8.8 HEX HEAD ZINC	F81001-62	4	
7	BOLT, M8x40-8.8 HEX HEAD FULL THREAD ZINC	F81002-15	4	
8	NUT, M6-8-B HEX NYLON ZINC LOCK	F81031-2	4	
9	NUT, M8-8-B HEX NYLON ZINC LOCK	F81032-2	4	
10	WASHER, 6.4 FLAT ZINC	F81053-1	8	
11	WASHER, 8.4 FLAT ZINC	F81054-1	8	
12	MAGNET, MW.38x12/N38 NEODYMIUM	500022	1	
13	VALVE, LES HAND PUMP RELIEF - COMPLETE	083712	1	
14	BLOCK, 4-WAY HYDRAULIC VALVE	502540-1	1	
15	CAP, 3/8 BSPP (G3/8)	502544	1	
	VALVE, H2/3-LES HYDRAULIC	502040	1	
16	FITTING, 3/8" BSP-9/16" JIC ELBOW	096335	4	
17	FITTING, G3/8-9/16-18JIC HAND PUMP	091842	1	
18	WASHER, 16x22 SEALING COPPER	502420	6	
19	FITTING, 3/8 BSP GZ STRAIGHT	503617	3	
20	FITTING, 3/8" BSP-GZ/GW 600 106 06 REDUCER	503616	3	
21	VALVE, 3/8 " G BALL	502056	3	
	PHD 2T3/8X4.200 W9/16UNF-W9/16UNF	502413	1	
22	FITTING, JIC 9/16-18	085900	2	
23	CRIMP SOCKET, 3/8" HYDRAULIC HOSE	085901	2	
24	HOSE, 3/8" (C/S-20MPa)P/N8106-6-06 HYDRAULIC	R02132	(4.2m)	
	HOSE, 2T3/8X4.200 W9/16UNF-W9/16UNF HYDRAULIC	502414	1	
25	FITTING, JIC 9/16-18	085900	2	
26	CRIMP SOCKET, 3/8" HYDRAULIC HOSE	085901	2	
27	HOSE, 3/8" (C/S-20MPa)P/N8106-6-06 HYDRAULIC	R02132	(7.2m)	
	PHD 2T3/8X4.200 W9/16UNF-W9/16UNF	502416	1	
28	FITTING, JIC 9/16-18	085900	2	

Log Clamp, Loading Ramp & Toe Board

H1/H2/H3 Control Assemblies - Options



29	CRIMP SOCKET, 3/8" HYDRAULIC HOSE	085901	2	
30	HOSE, 3/8" (C/S-20MPa)P/N8106-6-06 HYDRAULIC	R02132	(0.58m)	
	PHD 2T3/8X4.200 W9/16UNF-W9/16UNF	092357	1	
31	FITTING, JIC 9/16-18	085900	2	
32	CRIMP SOCKET, 3/8" HYDRAULIC HOSE	085901	2	
33	HOSE, 3/8" (C/S-20MPa)P/N8106-6-06 HYDRAULIC	R02132	(6.25m)	

9.5 Toe Board Roller Option

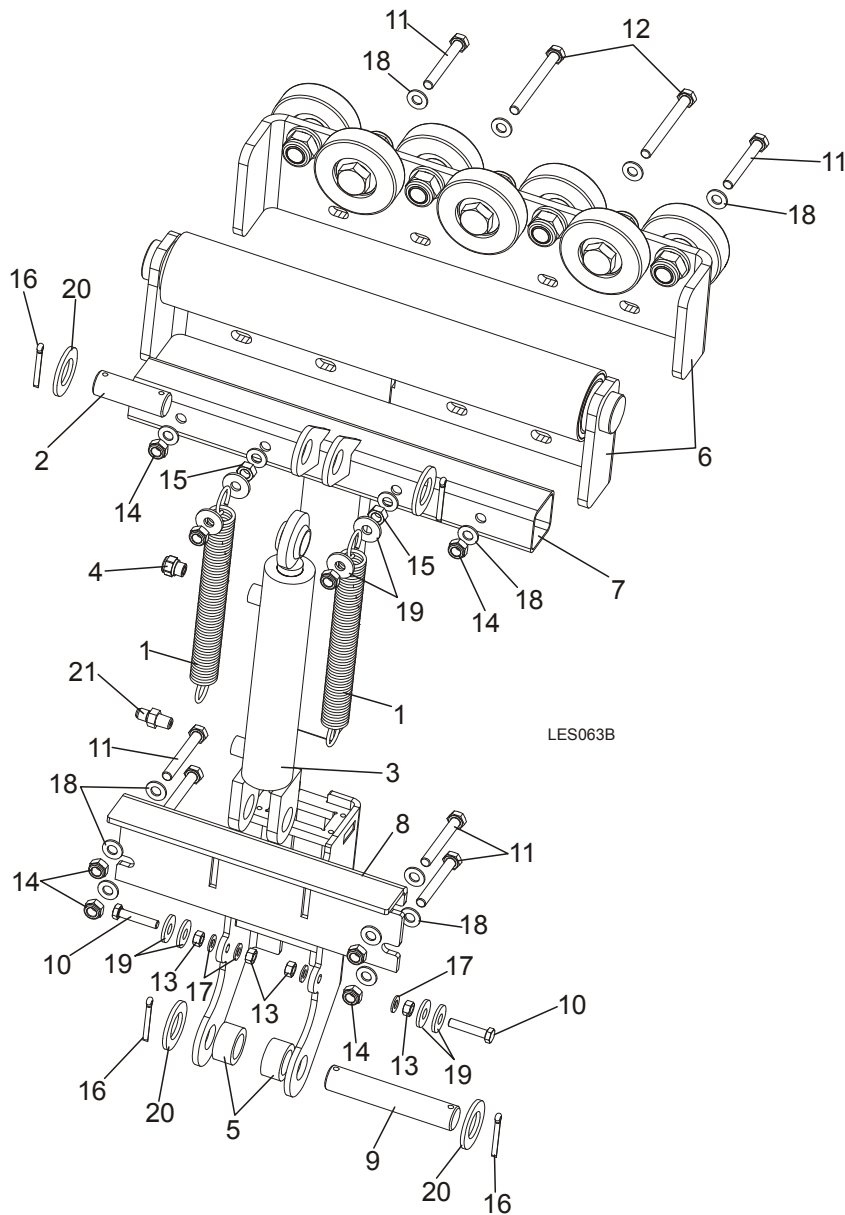

REF.	DESCRIPTION (◆ Indicates Parts Available In Assemblies Only)	PART #	QTY.
	KIT, ROLLER TOE BOARD	502110	1
1	SPRING, 1 1/16x8x.135 DIA	015718	2
2	PIN, 25X75 ZINC-PLATED	088659-1	1
3	CYLINDER, CJ-S170-16-40/25/152 HYDRAULIC	088681	1
4	AIR VENT VALVE 2901-14-17	090794	1
5	BUSHING, 38/25.4-19.6	505514-1	2
6	BRACKET, HYDRAULIC TOE BOARD - FRONT	502050-1	1
	RETROFIT KIT, ROLLER TURNER OPTION	504893-S	1
7	LINE FEED PART, TOE BOARD	502104-1	1
8	GUIDE, TOE BOARD ROLLER	502105-1	1

Log Clamp, Loading Ramp & Toe Board

Toe Board Roller Option



9	PIN, 25 x 140	502109-1	1	
10	BOLT, M8 X 45 - 8.8 HEX HEAD FULL THREAD ZINC	F81002-14	2	
11	BOLT, M10x75-8.8 HEX HEAD ZINC	F81003-15	6	
12	BOLT, M10x100-8.8 HEX HEAD FULL THREAD ZINC	F81003-91	2	
13	NUT, M8-8-B HEX ZINC	F81032-1	6	
14	NUT, M10-8-B HEX NYLON ZINC LOCK	F81033-1	8	
15	NUT, M10-8-B HEX ZINC	F81033-3	2	
16	PIN, 5 X 40 COTTER	F81043-31	4	
17	WASHER, 8.4 FLAT ZINC	F81054-1	4	
18	WASHER, 10.5 FLAT ZINC	F81055-1	16	
19	WASHER, 10.5 ZINC FLAT SPECIAL	F81055-6	8	
20	WASHER, 28 FLAT ZINC	F81061-1	4	
21	FITTING, 3/8JIC-1/4NPT STRAIGHT	015560	1	

9.6 Roller Turner Option

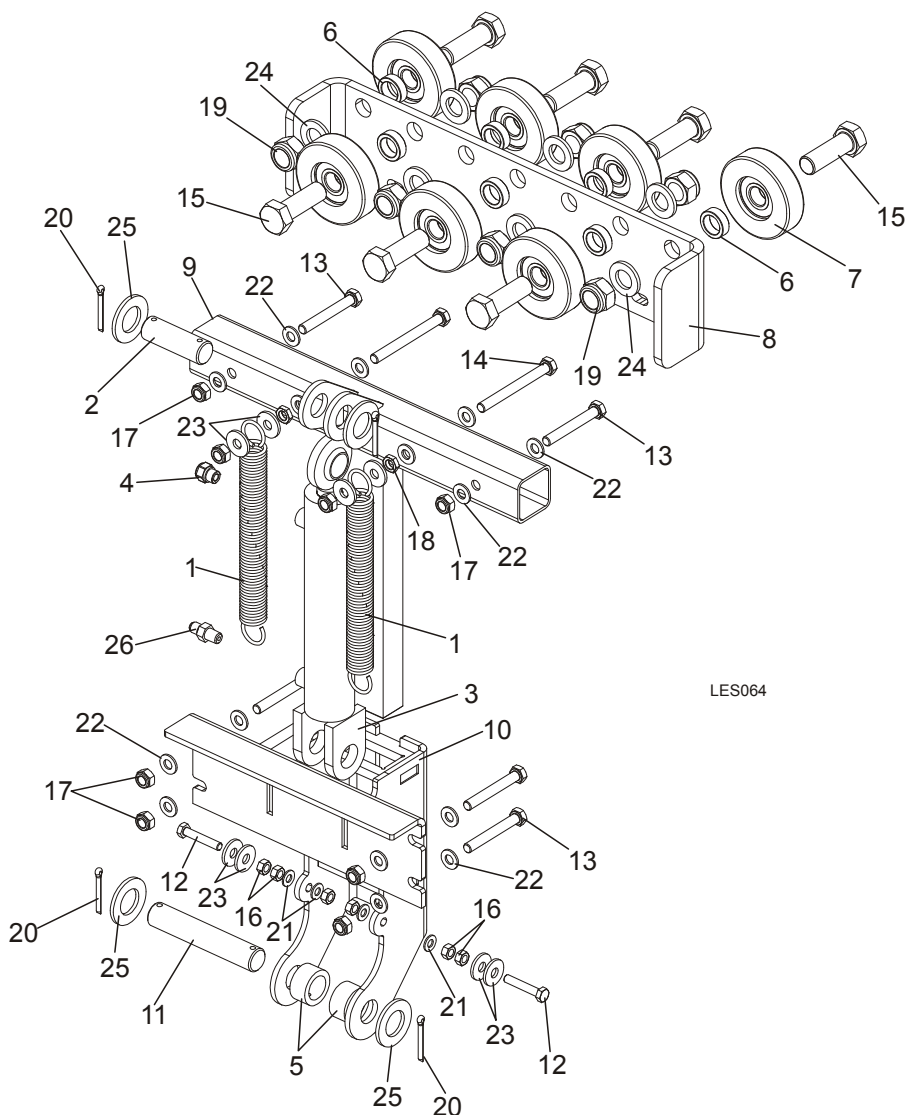

REF	DESCRIPTION (◆ Indicates Parts Available In Assemblies Only)	PART #	QTY.
	KIT, ROLLER TURNER	502309	1
1	SPRING, 1 1/16x8x.135 DIA	015718	2
2	PIN, 25X75 ZINC-PLATED	088659-1	1
3	CYLINDER, CJ-S170-16-40/25/152 HYDRAULIC	088681	1
4	AIR VENT VALVE 2901-14-17	090794	1
5	BUSHING, 38/25.4-19.6	505514-1	2
6	BUSHING, 21X30X10 SPACER ZINC	099351-1	7
7	ROLLER, RP-90, 6304 POLYURETHANE	099689	7
8	PLATE, TOE BOARD ROLLER MAIN	502037-1	1
9	LINE FEED PART, TOE BOARD	502104-1	1
10	GUIDE, TOE BOARD ROLLER	502105-1	1
11	PIN, 25 x 140	502109-1	1
12	BOLT, M8x45-8.8 HEX HEAD FULL THREAD ZINC	F81002-14	2

Log Clamp, Loading Ramp & Toe Board

Roller Turner Option



13	BOLT, M10X75-8.8 HEX HEAD ZINC	F81003-15	6	
14	BOLT, M10x100-8.8 HEX HEAD FULL THREAD ZINC	F81003-91	2	
15	BOLT, M20X60-8.8 HEX HEAD ZINC	F81007-7	7	
16	NUT, M8-8-B HEX ZINC	F81032-1	4	
17	NUT, M10-8-B HEX NYLON ZINC LOCK	F81033-1	8	
18	NUT, M10-8-B HEX ZINC	F81033-3	2	
19	NUT, M20-6 HEX	F81037-2	7	
20	PIN, 5 X 40 COTTER	F81043-31	4	
21	WASHER, 8.4 FLAT ZINC	F81054-1	4	
22	WASHER, 10.5 FLAT ZINC	F81055-1	16	
23	WASHER, 10.5 SPECIAL FLAT ZINC	F81055-6	8	
24	WASHER, 21 FLAT ZINC	F81059-2	7	
25	WASHER, 28 FLAT ZINC	F81061-1	4	
26	FITTING, 3/8JIC-1/4NPT STRAIGHT	015560	1	

9.7 Winch Option

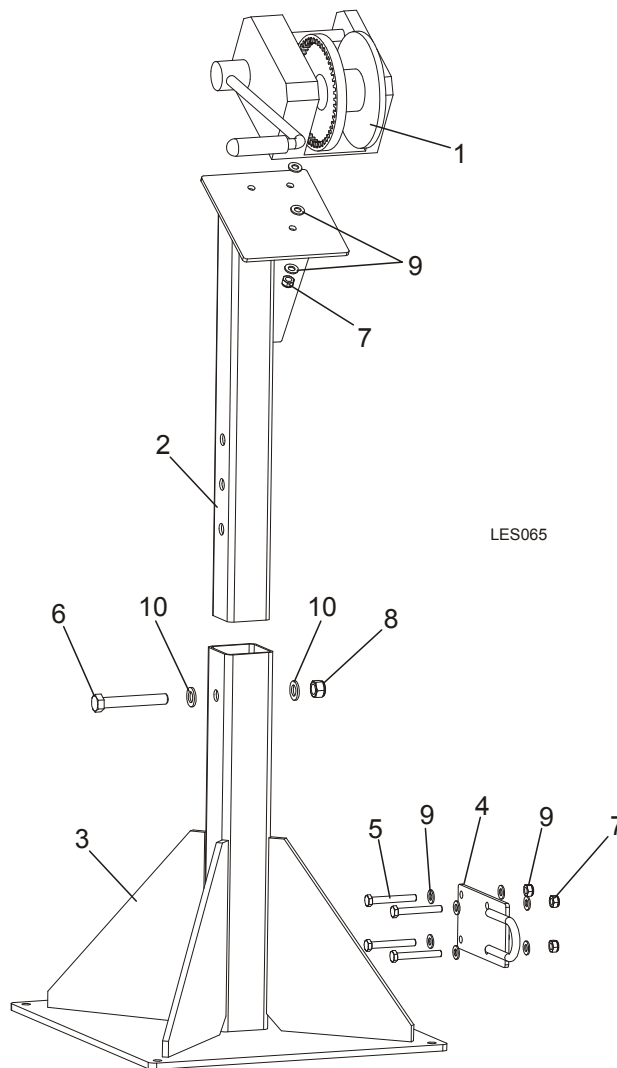

REF	DESCRIPTION (◆ Indicates Parts Available In Assemblies Only)	PART #	QTY.
	WINCH ASSEMBLY, LES	501341	1
1	WINCH, AL-KO TYPE 901	096453	1
2	TUBE, VERTICAL OUTRIGGER	501128-1	1
3	BASE WDMT, WINCH	502068-1	1
4	BRACKET, CABLE	502418-1	1
5	BOLT, M10x75-8.8 HEX HEAD ZINC	F81003-15	4
6	BOLT, M16x110-8.8 HEX HEAD ZINC	F81006-24	1
7	NUT, M10-8-B HEX NYLON ZINC LOCK	F81033-1	7
8	NUT, M16 HEX NYLON ZINC LOCK	F81036-2	1
9	WASHER, 10.5 FLAT ZINC	F81055-1	14
10	WASHER, 17 FLAT ZINC	F81058-1	2

9.8 Log Side Supports w/Lever Option

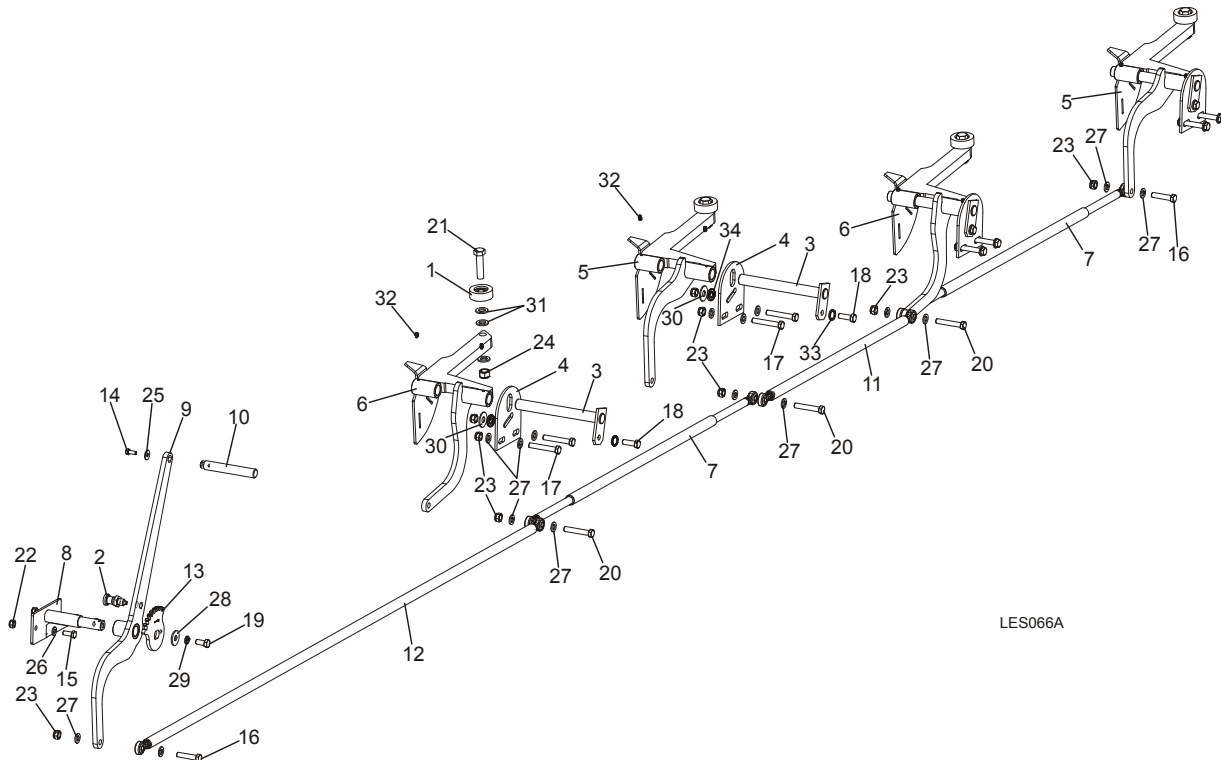

REF	DESCRIPTION (◆ Indicates Parts Available In Assemblies Only)	PART #	QTY.
	SUPPORT KIT, LOG SIDE W/LEVER	503672	1
1	ROLLER ASSY, SIDE SUPPORT	015014	4
2	PIN, DETENT	090197	1
3	PIN, SIDE SUPPORT ZINC-PLATED	091549-1	4
4	PLATE, LOG SIDE SUPPORT MOUNT PTD	091591-1	4
5	SIDE SUPPORT, W/COVER 1	502955-1	2
6	SIDE SUPPORT, W/COVER 2	502958-1	2
7	STRING, EXTREME COMPLETE	502961	2
8	SHAFT WELDMNT, COMPLETE	502966-1	1
9	LEVER	502977-1	1
10	KNOB, LEVER	502979	1
11	STRING, MIDDLE COMPLETE	502980	1
12	STRING, LEVER COMPLETE	502981	1
13	BLOCK, SIDE SUPPORT LEVER	502982-1	1
14	BOLT, M8X20-5.8 HEX HEAD FULL THREAD ZINC	F81002-1	1
15	BOLT, M10X25-8.8 HEX HEAD FULL THREAD ZINC	F81003-11	2
16	BOLT, M12X55-8.8 HEX HEAD ZINC	F81004-12	2
17	BOLT, M12 X 75-8.8 ZINC	F81004-21	8
18	BOLT, M12 X 35-8.8-FE/ZN5 HEX HEAD FULL	F81004-24	4
19	BOLT, M12X25-8.8 HEX HEAD FULL THREAD ZINC	F81004-31	1
20	BOLT, M12x70 8.8 HEX HEAD ZINC	F81004-39	3
21	BOLT, M16x65-8.8 HEX HEAD FULL THREAD ZINC	F81006-1	4
22	NUT, M10-8-B HEX NYLON ZINC LOCK	F81033-1	2

9 **Log Clamp, Loading Ramp & Toe Board**
Log Side Supports w/Lever Option

23	NUT, M12-8 HEX NYLON ZINC LOCK	F81034-2	17	
24	NUT, M16,HEX, NYLON ZINC LOCK	F81036-2	4	
25	WASHER, 8.5 FLAT, ZINC SPECIAL	F81054-11	1	
26	WASHER, 10.5 FLAT ZINC	F81055-1	2	
27	WASHER, 13 FLAT ZINC	F81056-1	26	
28	WASHER, 13 SPECIAL FLAT ZINC	F81056-14	1	
29	WASHER, Z12.2 SPLIT LOCK ZINC	F81056-2	1	
30	WASHER, 15 SPECIAL FLAT ZINC	F81057-3	1	
31	WASHER, 17 FLAT ZINC	F81058-1	12	
32	FITTING, 3/16X3/16 STRAIGHT GREASE	P04107	9	
33	WASHER, SPECIAL BOSART/2S, BN781 M12/13	F81056-16	4	
34	WASHER, SPECIAL BOSART/2S M12/12,3/30,3	F81056-17	4	