

user manual

Instrukcja obsługi | Руководство пользователя
Manuel de l'Utilisateur | Betriebsanweisung
Bruksanvisning | Manual del Usuario
Betjeningsvejledning | Gebruikershandleiding
Käyttöohjeet | Manual de utilizare | Bruksanvisning
Manuale d'uso | Příručka uživatele | Navodila
za uporabo

Retain for future use
Zachować do przyszłego użytku
Сохраните для последующего
использования
A conserver pour une utilisation future
Für zukünftige Benutzung aufbewahren
Behold for senere bruk
Säilytä nämä käyttöohjeet tulevaa tarvetta marten
Opbevar manualen til fremtidig brug
Bewaren voor gebruik in de toekomst
Conservare il presente manuale a l'uso futuro
Păstrați acest manual pentru utilizare viitoare
Conservar para futuras consultas
Behall för framtida användning
Uchovejte pro další použití
Hranite za prihodnjo uporabo

Wood-Mizer® Sawmill

Safety, Setup, Operation & Maintenance Manual

LT40 B1-4 AH	rev. A2.03
LT40 B1-4 AH WIDE	rev.A2.03
LT40 B1-4 DH	rev.A3.03
LT40 B1-4 DH WIDE	rev. A3.03



Safety is our #1 concern! Read and understand all safety information and instructions before operating, setting up or maintaining this machine.

**This is the original language
for the manual.**

This manual is to replace or to be used with all previous information received on the Wood-Mizer® sawmill. All future mailings will be an addition to or a revision of individual sections of this manual as we obtain new information.

The information and instructions given in this manual do not amend or extend the limited warranties for the equipment given at the time of purchase.

If You Need To Order Parts...

From Europe call our European Headquarters and Manufacturing Facility in Kolo, Poland at **+48-63-2626000**. Please have the vehicle identification number and your customer number ready when you call. Wood-Mizer will accept these methods of payment:

- Visa, Mastercard, or Select Purchase
- COD
- Prepayment
- Net 15 (with approved credit)

Be aware that shipping and handling charges may apply. Handling charges are based on size and quantity of order. In most cases, items will ship on the day they are ordered. Second Day and Next Day shipping are available at additional cost.

If You Need Service...

From Europe call our European Headquarters and Manufacturing Facility in Kolo, Poland at **+48-63-2626000**. Ask to speak with a Customer Service Representative. Please have your vehicle identification number and your customer number ready when you call. The Service Representative can help you with questions about alignment of your mill, blade sharpening, or cutting a particular species of wood. He also can schedule you for a service call.

Office Hours: All times are Eastern Standard Time. Please remember that Indiana does not observe Daylight Savings Time in the summer.

Company Identification Number
456=Wood-Mizer, Indiana

Weight Class; A=Under 1800kg, B=1800-2200kg, C=1801-2200 kg, D=2201-3000kg, X=Stationary.

Prod No.; 1=LT110 Series, 2=LT200 Series, 7=LT70 Series

Length of the Trailer (m), 24=24m, 25=25m, 26=26m, 27=27m, 35=35m (11 m)

Number of axles on the trailer

Code of Mill

Adjust the number and divide by 11

Year of Manufacture

N=2015, P=2016, R=2017, S=2018, T=2019

State of Manufacture

N=Indiana, C=Canada, F=France, M=Month of Manufacture

January, B=February, C=March, etc...

Revision Level

Sequence Number ranging from 000-999

End of Digit VIN

Revision Level (Repeated)

Two-Digit Minor Revision Level

Entry

Monday - Friday

Saturday

Sunday

IMPORTANT! Read the entire Operator's Manual before operating the sawmill. Take notice of all safety warnings throughout this manual and those posted on the machine. Keep this manual with this machine at all times, regardless of ownership.

*Wood-Mizer® is a registered trademark of Wood-Mizer Products, Inc.

Sawmill and Customer Identification

Each Wood-Mizer sawmill has a 17-digit Vehicle Identification Number (VIN). See the figure below for VIN locations. See the chart for VIN description.

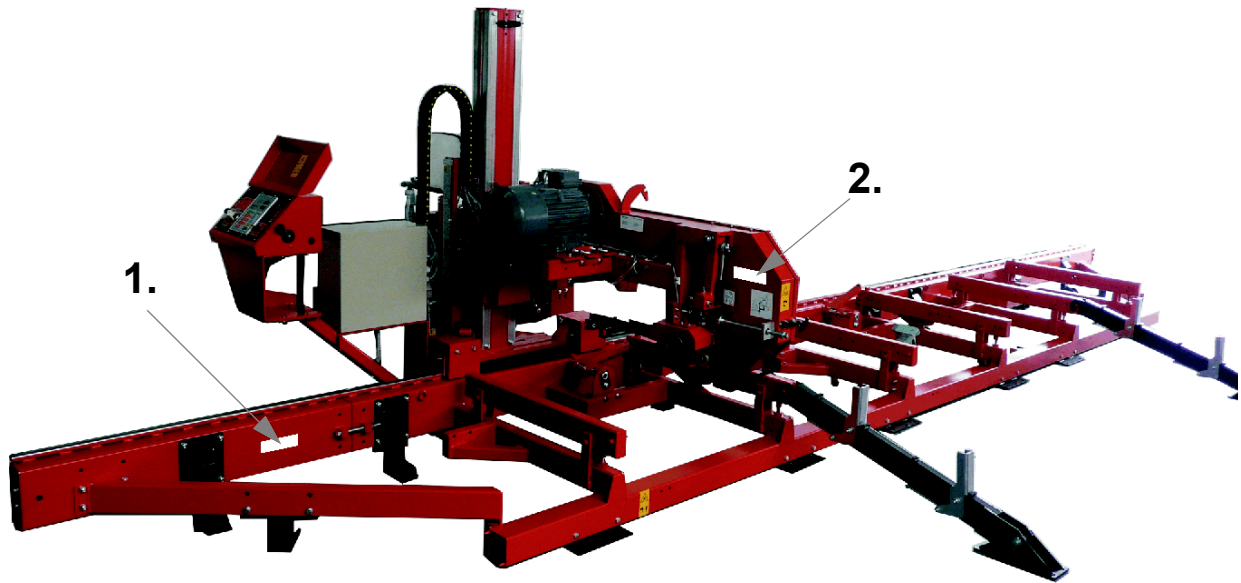

V.I.N. LOCATIONS.

456	A	4	24	1	X	H	P	A	F9	017		F9	.01

V.I.N. DESCRIPTION

LT40
Basic Sawmill I.D.

E25
Engine/Motor Configuration

Getting Service

Wood-Mizer is committed to providing you with the latest technology, best quality and strongest customer service available on the market today. We continually evaluate our customers' needs to ensure we're meeting current wood-processing demands. Your comments and suggestions are welcome.

General Contact Information

From Europe call your local distributor or our European Headquarters and Manufacturing Facility in Koło, Nagórna 114 St, Poland at **+48-63-2626000**. From the continental U.S., call our U.S. Headquarter 8180 West 10th St. Indianapolis, IN 46214, toll-free at **1-800-525-8100**. Ask to speak with a Customer Service Representative. Please have your machine identification number and your customer number ready when you call. The Service Representative can help you with questions about the operation and maintenance of your machine. He also can schedule you for a service call.

Office Hours:

Country	Monday - Friday	Saturday	Sunday
Poland	7 a.m.- 3 p.m.	Closed	Closed
US	8 a.m.- 5 p.m.	8 a.m.- 12 p.m	Closed

Please have your vehicle identification number and your customer number ready when you call.

Wood-Mizer will accept these methods of payment:

- Visa, Mastercard, or Discover
- COD
- Prepayment
- Net 15 (with approved credit)



Be aware that shipping and handling charges may apply. Handling charges are based on size and quantity of order.

Technical data are subject to change without prior notice.

Actual product may differ from product images. Some illustrations show machines with optional equipment.

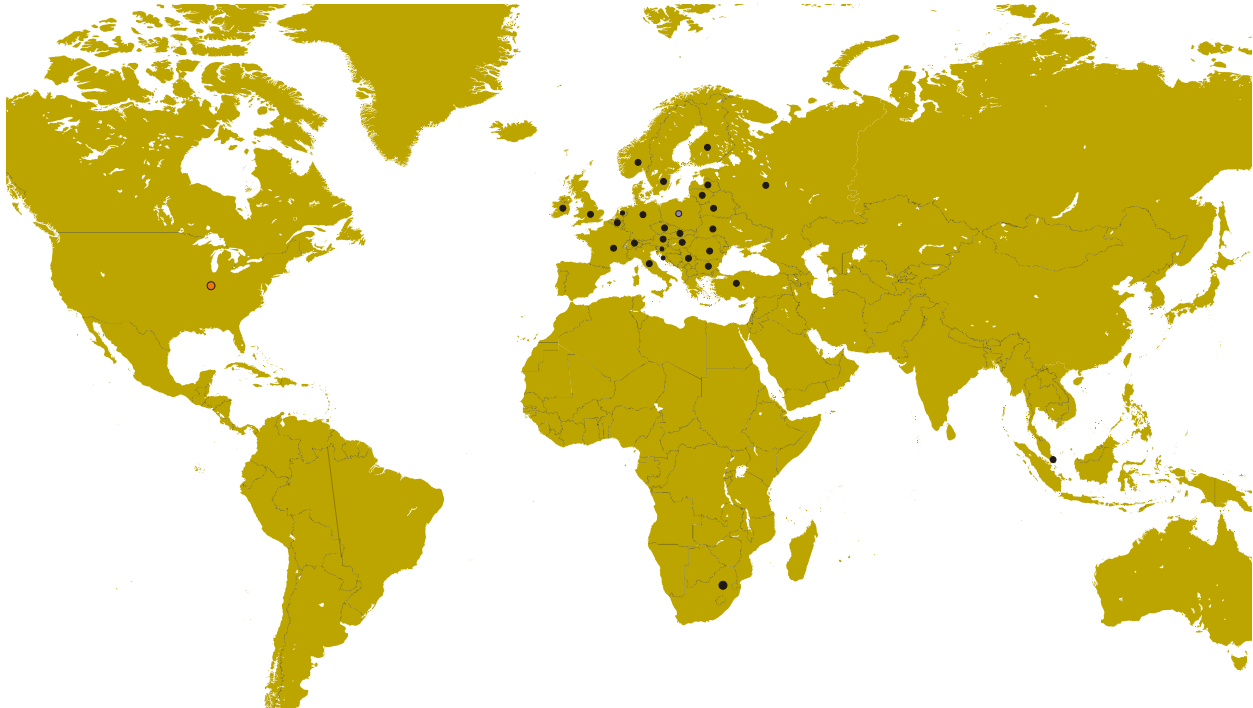
Branches & Authorized Sales Centers Wood-Mizer Locations (North and South America)



EUROPE		UNITED STATES
<p> European Headquarters Wood-Mizer Industries Sp. z o.o. Nagórna 114, 62-600 Kolo, Poland Tel.: +48-63-26-26-000 Fax: +48-63-27-22-327 www.woodmizer.eu</p>		<p> World Headquarters Wood-Mizer LLC 8180 West 10th Street Indianapolis, Indiana 46214-2400, USA Tel.: +1-317-271-1542 Fax: +1-317-273-1011 www.woodmizer.com</p>
<p>BELARUS MOST-GRUPP Siemashko 15, k.3 Minsk 2200116 Tel.: +375-17-270-90-08 Fax: +375-17-270-90-08 GSM: +375-29-649-90-80 e-mail: most-by@mail.ru</p>	<p>SWITZERLAND Stefan Wespi Maschinen u. Geräte Spezialarbeiten GmbH Eichstraße 4 6353 Weggis Tel.: +41-413-900-312 GSM: +41-799-643-594 info@woodmizer.ch www.woodmizer.ch</p>	<p>RUSSIA Dariusz Mikołajewski OOO WOOD-MIZER INDUSTRIES 141031, Moscow Reg., Mytishenski raj., pos. Veshki, Zavodskaja str., 3B Tel.Fax: +7(495) 788-72-35 Tel.Fax: +7(495) 641-51-60 e-mail: dariuszm@woodmizer-moscow.ru</p>
<p>BULGARIA Kalin Simeonov Ecotechproduct 38 Star Lozenski pat str. Sofia 1186 Tel.: +359-2-462-7035 Tel.: +359-2-963-1656 Tel./Fax : +359-2-979-1710 Kalin Simeonov GSM: +3592-963-2559 e-mail: office@ecotechproduct.com</p>	<p>HUNGARY Wiktor Turoczy Wood-Mizer Hungary K.F.T. Szonyi Ut 67., 2921 Komárom Tel./Fax: +36-34-346-255 e-mail: woodmizer@woodmizer.hu</p>	<p>RUSSIA Far East Wladimir Glazaczew "WM Service" Krasnoretchenskaya Str.111 680006 Khabarovsk Tel./Fax: +7-914-541-1183 e-mail: wms-khv@mail.ru</p>

<p>CROATIA Krešimir Pregernik Pregimex d.o.o. S. Batušića 31, 10090 Zagreb Tel./Fax: +3851-38-94-668 Krešimir Pregernik GSM: +3851-98-207-106 e-mail: Kresimir.Pregernik@gmail.com</p>	<p>ITALY Pasquale Felice Wood-Mizer Italia Srl Cda. Capoiaccio SN 86012 Cercemaggiore Campobasso Tel./Fax: +39-0874-798-357 GSM: +39-333-281-03-79 e-mail: wmitaliasrl@gmail.com</p>	<p>SERBIA Dragan Markov Wood-Mizer Balkan d.o.o. Svetosavska GA 3/3; P. Fah 25 23 300 Kikinda Tel./Fax: +381-230-25-754 Tel./Fax: +381-230-23-567 GSM: +381-63-568-658 e-mail: office@woodmizer.co.yu</p>
<p>CZECH REPUBLIC Miroslav Greill Wood-Mizer CZ s.r.o. Za Kasárny 946 339 01 Klatovy Tel: +420-376-312-220 GMS: +420-608-111-104 Miroslav Greill GMS: + 420-602-439-799 E-mail: woodmizer@woodmizer.cz</p>		<p>SLOVAKIA Wiktor Turoczy Wood-Mizer Danubia s.r.o. Hadovce 5, 94501 Komárno Tel.: +421-35-77-40-316 Fax: +421-35-7740-326 GSM: +421-905-930-972 e-mail: woodmizer@woodmizer.sk</p>
<p>CZECH REPUBLIC Lubomir Kudlik Wood-Mizer Moravia Sovadinova 6 69002 Breclav Tel./Fax: +420-519-322-443 Lubomir Kudlik GSM: +420-602-734-792 e-mail: info@wood-mizer.net</p>	<p>LATVIA Vilmars Jansons OBERTS Ltd Gaujas str. 32/2 LV-2167 Marupe, Rigas Raj. Tel.: +371-7-810-666 Fax: +371-7-810-655 Vilmars Jansons GSM: +371-92-06-966 Andris Orols GSM: +371-28-33-07-90 e-mail: andris@oberts.lv</p>	<p>TURKEY Er-Ka Ahsap Profil Kerestecilik San. ve Tic. Ltd. Sti. Adana Keresteciler Sitesi 191 sk No.41 ADANA Tel.: +90-322-346-15-86 Fax: +90-322-345-17-07 GSM: +90-533-363-18-44 e-mail: info@erkaahsap.com.tr</p>
<p>FINLAND Howard Blackbourn Oy Falkberg Jordbruk Ab Falkintie 220 25610 Ylonkyla Tel.: +358-2732-2253 Fax: +358-2732-2263 Howard Blackbourn GSM: +358-440-424-339 e-mail: falkberg@woodmizer.fi</p>	<p>LITHUANIA Andrius Zuzevicius UAB Singlis Savanoriu pr. 187, 2053 Vilnius Tel.: +370-5-2-32-22-44 Fax: +370-5-2-64-84-15 GSM: +370-620-28-645 e-mail: andrius.z@singlis.lt Dmitrij Gaiduk GSM: +370-69-84-51-91 e-mail: dmitrijus.g@singlis.lt</p>	<p>UKRAINE Ivan Vinnicki MOST UKRAINA bul. Myru 3, Bajkivtsi Ternoplskyj r-j Ternopolska oblast 47711 Ukraine Tel/Fax: +38 (0352) 52 37 74 GSM: +38 (067) 352 54 34 GSM: +38 (067) 674 50 68 E-mail: most-ukraine@ukr.net</p>
<p>FRANCE Tizoc Chavez Wood-Mizer France 556 chemin des Embouffus, ZAC des Basses Echarrieres 38440 SAINT JEAN DE BOURNAY Tel: +33-4 74 84 84 44 GSM: +33-607 52 02 82 Mail: tchavez@woodmizer.fr</p>	<p>NORWAY Tor Bakken Flaathe Bakken Flaathe A/S Løkenvegen 5, 2034 Holter Tel: + 47-638 74 989 Sales: + 47- 412 80 076 Service: +47- 975 87 588 post@woodmizer.no www.woodmizer.no</p>	<p>UNITED KINGDOM & IRELAND Wood-Mizer UK Hopfield Barn Kenward Road, Yalding Kent ME18 6JP, UK Tel.: +44-1622-813-201 Fax: +44-1622-815-534 e-mail: info@woodmizer.co.uk</p>
<p>SLOVENIA Jan Fale FAMTEH d.o.o. Gacnikova pot 2, 2390 Ravne na Koroskem Tel.: +386-2-62-04-232 Fax: +386-2-62-04-231 Jan Fale GSM: +386-2-62-04-230 e-mail: jan.fale@famteh.si Matjaz Kolar Tel.: +386-2-62-04-232 GSM: +386-31-775-999 e-mail: matjaz.kolar@famteh.si</p>		

<p>GERMANY/AUSTRIA Klaus Longmuss Wood-Mizer GmbH Dorfstraße 5, 29485 Schletau Büro Tel: +49-5883 988 010 Werkstatt Tel: +49-5883 988 220 Ersatzteilservice Tel: +49 58 83 - 98 80 250 Schärfservice Tel: +49-58 83 - 98 80 270 E-mail: info@woodmizer.de www.woodmizer.de Klaus Longmuss Tel.: +49-5883-9880-12 GSM: +49-17-298-55-892 e-mail: KLongmuss@woodmizer.de</p>	<p>Subagent: SWEDEN Kjell Larsson Mekwood AB Slingan 14, 812 41 Gästrike-Hammarby Tel.: +46-290-515-65 Kjell Larsson GSM: +46-706-797-965 e-mail: kjell.larsson@mekwood.se</p>	<p>IRELAND Wood-Mizer Ireland Stephen Brennan Cum Lahardane Ballina County Mayo Tel:+353 96 51345 E-mail: brennanmill@ericom.net</p>
<p>Subagents: DENMARK Kevin Christiansen Kevin Christiansen's savværker PMV Arnborgvej 40, 7330 Brande- Fasterholt Mobile: +45 61468763 Mobile: +45-23495828 Info@woodmizer.dk www.woodmizer.dk</p>	<p>ROMANIA Adrian Echert SC WOOD-MIZER RO SRL TRANSILVANIEI Nr. 5 Sibiu, Cisanadie 555300 Tel./Fax: : +40-369-405-433 GSM: +40-745-707-323 e-mail: aechert@woodmizer.ro</p>	<p>Regional Manager - Asia Robert Moxham Regional Direction - Asia Wood-Mizer Asia Manufacturing Co., Ltd. No.2, Gongyequ 40th Rd. Xitun District, Taichung City, 40768, Taiwan, R.O.C. TEL: +886-4-2359 3022 FAX: +886-4-2359 3205 CELL: +886-9-0568 7708 EMAIL: RMoxham@woodmizer.com www.woodmizerasia.com Skype: r.g.moxham</p>
<p>NETHERLANDS Gerlo Breukers Breukers Houtzagerij en Bosbouwmachines Hazenweg 5, 7481 PC Haaksbergen Tel: +31-535741326 Mobile: +31-620419412 info@woodmizer.nl www.woodmizer.nl</p>	<p>Subagent: ROMANIA M. Echert S.C. Echert Comprod s.r.l Str. Schitului Nr. 6, Apt.7 etajul-1 725 70 Vatra Dornei, Romania Tel./Fax: +40-230-374-235 Tel. : +40-740-35-35-74</p>	<p>Regional Manager - Africa Gavin Prowse Regional Sales Director - Africa Wood-Mizer Africa (Pty) Ltd. Unit 1, Leader Park 20 Chariot Street Stormill Ext.5 Maraisburg, Johannesburg South Africa TEL: +27 11 473 1313 FAX: +27 11 473 2005 CELL: +27 71 398 8010 EMAIL: growse@woodmizer.com www.woodmizerafrika.com Skype: gavin.prowse</p>

USA World Headquarters

Serving North & South America, Oceania, East Asia

Wood-Mizer LLC
8180 West 10th Street
Indianapolis, IN 46214

Phone: 317.271.1542 or 800.553.0182
Customer Service: 800.525.8100
Fax: 317.273.1011
Email: infocenter@woodmizer.com

Brazil Headquarters

Serving Brazil

Wood-Mizer do Brasil
Rua Dom Pedro 1, No: 205 Bairro: Sao Jose
Ivoti/RS CEP:93.900-000

Tel: +55 51 9894-6461/ +55 21 8030-3338/ +55 51 3563-4784
Email: info@woodmizer.com.br

Canadian Headquarters

Serving Canada

Wood-Mizer Canada
396 County Road 36, Unit B
Lindsay, ON K9V 4R3

Phone: 705.878.5255 or 877.357.3373
Fax: 705.878.5355
Email: ContactCanada@woodmizer.com

Europe Headquarters

Serving Europe, Africa, West Asia

Wood-Mizer Industries Sp z o.o.
Nagorna 114
62-600 Kolo, Poland

Phone: +48.63.26.26.000
Fax: +48.63.27.22.327

Branches & Authorized Sales Centers

For a complete list of dealers, visit www.woodmizer.com

Table of Contents

Section-Page

General Contact Information

Branches & Authorized Sales Centers Wood-Mizer Locations (North and South America)

SECTION 1	SAFETY & GENERAL INFORMATION	1-1
1.1	Blade Handling.....	1-1
1.2	Sawmill Setup.....	1-2
1.3	Sawmill Operation.....	1-2
1.4	Sawmill Maintenance	1-5
1.5	Belt Sizes	1-10
1.6	Blade Sizes	1-11
1.7	Cutting Capacity	1-11
1.8	Engine/Motor Specifications	1-12
1.9	Noise Level.....	1-14
1.10	Overall Dimensions	1-15
1.11	Chains	1-15
1.12	Hydraulic System	1-15
1.13	Dust Extractor Specifications	1-16
1.14	Components	1-17
SECTION 2	SAWMILL ASSEMBLY	2-1
2.1	Mounting Parts of LT40 Sawmills	2-1
	<i>Specifications of Parts</i>	
	<i>Specifications of Fasteners</i>	
	<i>Tools Necessary for Assembling the Sawmill</i>	
2.2	Unpacking the Sawmill	2-6
	<i>Standard Version of the Sawmill</i>	
	<i>Sawmill with Remote Equipment</i>	
2.3	Bed Frame Assembly	2-9
SECTION 3	SETUP & OPERATION	3-1
3.1	Sawmill Setup.....	3-1
	<i>Setting up sawmills equipped with non-adjustable legs</i>	
	<i>Setting up sawmills equipped with outrigger legs</i>	
3.2	Sawmills with cable guide.....	3-6
3.3	Middle Track Cover	3-11
3.4	Replacing The Blade	3-13
3.5	Tensioning The Blade.....	3-14
3.6	Tracking The Blade	3-15
3.7	Starting The Motor (LT40 B1-4 AC)	3-17
3.8	Starting The Engine (LT40 B1-4 DC).....	3-18
3.9	Loading, Turning, And Clamping Logs	3-20
3.10	Up/Down Operation	3-22
3.11	Blade Guide Arm Operation.....	3-23

Table of Contents

Section-Page

3.12	Clutch/Brake Operation.....	3-24
3.13	Power Feed Operation	3-26
3.14	Blade Height Scale	3-27
3.15	Water Lube Operation	3-30
SECTION 4 MAINTENANCE		4-1
4.1	Wear Life.....	4-1
4.2	Blade Guides	4-2
	<i>Steel Blade Guide Blocks</i>	
4.3	Sawdust Removal	4-3
4.4	Carriage Track, Wiper & Scrapers	4-4
4.5	Vertical Mast Rails	4-5
4.6	Drum Switches	4-5
4.7	Miscellaneous	4-6
4.8	Blade Tensioner.....	4-7
4.9	Brake Strap Adjustment	4-9
4.10	Blade Wheel Belts	4-9
4.11	Drive Belt Adjustment.....	4-10
4.12	Clutch Handle Adjustment	4-13
4.13	Autoclutch Option Adjustment.....	4-14
4.14	Drive Bearing	4-15
4.15	Up/Down System.....	4-16
4.16	Power Feed	4-18
4.17	Safety Devices Inspection	4-20
SECTION 5 TROUBLESHOOTING GUIDE		5-1
5.1	Sawing Problems	5-1
5.2	Electrical Problems.....	5-3
5.3	Power Feed Problems	5-5
5.4	Motor and Drive Pulleys Alignment	5-7
5.5	Power Feed Variable Speed Switch Test.....	5-8
5.6	Power Feed Preliminary Test	5-8
5.7	Power Feed Mechanical Test.....	5-8
SECTION 6 SAWMILL ALIGNMENT		6-1
6.1	Pre-Alignment Procedures.....	6-1
6.2	Frame Setup.....	6-2
6.3	Blade Installation And Alignment.....	6-2
6.4	Saw Head Slide Pad Adjustment.....	6-6
6.5	Adjusting The Lower Track Rollers.....	6-9
6.6	Adjusting Bed Rails To The Blade.....	6-13
6.7	Blade Guide Arm Alignment.....	6-14
6.8	Blade Deflection.....	6-20

Table of Contents

Section-Page

6.9 Blade Guide Vertical Tilt Adjustment.....6-22
6.10 Blade Guide Spacing6-25
6.11 Horizontal Tilt Adjustment.....6-27
6.12 Blade Guide Disc Adjustment.....6-29
6.13 Horizontal Adjustment of Side Supports.....6-32
6.14 Vertical Adjustment of Side Supports.....6-34
6.15 Saw Head Tilt.....6-35
6.16 Blade Height Scale Adjustment.....6-38

SECTION 1 SAFETY & GENERAL INFORMATION



This symbol calls your attention to instructions concerning your personal safety. Be sure to observe and follow these instructions. This symbol accompanies a signal word. The word **DANGER** indicates an imminently hazardous situation which, if not avoided, will result in death or serious injury. **WARNING** suggests a potentially hazardous situation which, if not avoided, could result in death or serious injury. **CAUTION** refers to potentially hazardous situations which, if not avoided, may result in minor or moderate injury to persons or equipment. Read all safety instructions before operating this equipment and observe all safety warnings!



Warning stripes are placed on areas where a single decal would be insufficient. To avoid serious injury, keep out of the path of any equipment marked with warning stripes.

Read and observe all safety instructions before operating this equipment! Also read any additional manufacturer's manuals and observe any applicable safety instructions including dangers, warnings, and cautions.

Always be sure that all safety decals are clean and readable. Replace all damaged safety decals to prevent personal injury or damage to the equipment. Contact your local distributor, or call your Customer Service Representative to order more decals.

IMPORTANT! It is always the owner's responsibility to comply with all applicable federal, state and local laws, rules and regulations regarding the ownership, operation and towing of your Wood-Mizer sawmill. All Wood-Mizer mill owners are encouraged to become thoroughly familiar with these applicable laws and comply with them fully while using or towing the mill.

Always properly dispose of all sawing by-products, including sawdust and other debris, coolant, oil, fuel, oil filters and fuel filters.

Safety instructions are listed in this section by the following operations:

- Blade Handling
- Sawmill Setup
- Sawmill Operation
- Sawmill Maintenance

1.1 Blade Handling



DANGER! Shut off the sawmill motor before changing the blade. Failure to do so will result in serious injury.



WARNING! Always wear gloves and eye protection when handling bandsaw blades. Changing blades is safest when done by one person! Keep all other persons away from area when coiling, carrying or

changing a blade. Failure to do so may result in serious injury.



WARNING! Do not spin the blade wheels by hand. Spinning the blade wheels by hand may result in serious injury.

1.2 Sawmill Setup



WARNING! Securely fasten the feet of a stationary sawmill to the floor before operating the sawmill. Failure to do so may result in serious injury or death.

WARNING! Do not set up the mill on ground with more than a 10 degree incline. If setup on an incline is necessary, put blocks under one side of the mill or dig out areas for outrigger legs to keep mill level. Setting up the mill on an incline could cause it to tip over, resulting in serious personal injury.



CAUTION! Changes in temperature could cause increased pressure in the blade tensioner and loss of fluid from the gauge. Release the blade tension when the mill is not in use to avoid damage to the tensioner.

1.3 Sawmill Operation



IMPORTANT! The sawmill is intended for sawing wood only. [See Section 1.7](#) for log size capacities of the machine.

IMPORTANT! The operator of the sawmill should get adequate training in the operation and adjustment of the machine.



DANGER! Make sure all guards and covers are in place and secured before operating or towing the sawmill. Failure to do so may result in serious injury.

Be sure the blade housing and pulley covers are in place and secure. Use the safety retainer pin and cable to fasten blade housing covers.

DANGER! Always keep hands away from moving bandsaw blade. Failure to do so will result in serious injury.



DANGER! Stay clear of the area between the trailer axle and saw carriage. Failure to do so will result in serious injury.

DANGER! Keep all persons out of the path of moving equipment and logs when operating sawmill or loading and turning logs. Failure to do so will result in serious injury.

DANGER! Maintain a clean and clear path for all necessary movement around the mill and lumber stacking areas. Failure to do so will result in serious injury.

DANGER! Always be sure the blade is disengaged and all persons are out of the path of the blade before starting the engine or motor. Failure to do so will result in serious injury.

DANGER! Keep all persons out of the path of returning boards. Failure to do so will result in serious injury.



WARNING! Always wear eye, ear, respiration, and foot protection when operating the sawmill. Failure to do so may result in serious injury.

WARNING! Be sure the power feed switch is in the neutral position before turning the key switch to the (#1) or (#2) position. This prevents accidental carriage movement which may cause serious injury or death.



WARNING! Secure all loose clothing and jewelry before operating the sawmill. Failure to do so may result in serious injury or death.

WARNING! Always make sure log is clamped securely before sawing. Failure to do so may result in serious injury or death.

WARNING! Use ONLY water with the water lube accessory. Never use flammable fuels or liquids. If these types of liquids are necessary to clean the blade, remove it and clean with a rag. Failure to do so may result in serious injury or death.



CAUTION! Be sure the pivot rails, turning arm, clamp, and toe boards are below bed level before loading a log onto the bed. Failure to do so may result in machine damage or cause misalignment.

CAUTION! Before loading a log, be sure the cutting head is moved far enough forward so the log does not hit it. Failure to do so may result in machine damage.

CAUTION! Do not try to force the saw head beyond its upper and lower travel limits. Damage to the up/down system may result.

CAUTION! Always make sure the up/down switch moves to the neutral or off position when released to ensure that the saw head stops moving. Failure to do so may result in machine damage.

CAUTION! Be sure to stop the blade when returning the carriage. This will not only prevent the blade from being pulled off and ruined by a wood sliver, but also will increase the life of the blade.



DANGER! Any arbitrary repairs of the electric installation could result in serious injury or death.

DANGER! Any damaged electric parts, especially the wires supplying

the power feed motors must be repaired by a qualified electrician.

DANGER! Any repairs done to the electric installation may be done by a qualified electrician with the power off.

DANGER! The electric connector must be equipped with a safety device to protect against shock.

DANGER! The electric connector must be installed by a qualified electrician.

DANGER! Do not operate the sawmill with an open electric box.

DANGER! In the event that water appears in the electric box further work on the sawmill may result in electric shock as well as damage to the power feed motor.

DANGER! The electric box door must always be closed, even when the sawmill is not in use.

DANGER! Always disconnect the power when the sawmill has been not in use for a long period.

DANGER! Any maintenance or repair must be done with the power off (the plug must be taken out of the outlet).

DANGER! Maintain a clean and clear path for all necessary movement around the mill and lumber stacking areas. Failure to do so will result in serious injury.

CAUTION! Be sure all safety plates are clean and readable. For new safety plates please contact your local distributor.

CAUTION! The saw head will hit the spring-loaded ramp stops when adjusted for low cuts. Remove the loading ramps before sawing to prevent damage to the saw head and/or blade guide arm.



CAUTION! Never clean the blade or the blade wheels with a brush or a scraper during sawmill operation.

CAUTION! Before installation of the blade, inspect it for damage and cracks. Use only properly sharpened blades. Always handle the blade with extreme caution. Use suitable carrier equipment for transporting the blades.

CAUTION! Always wear gloves when handling the blade. Never grab the blade with bare hands!

CAUTION! If the blade breaks during sawmill operation, push the EMERGENCY STOP button to stop the blade motor and wait 10 sec-

onds before you open the blade housing cover.

CAUTION! The sawmill's work-stand should be equipped with a 4 kg or bigger dry powder extinguisher.

1.4 Sawmill Maintenance



WARNING! Always secure the cutting head with a chain or a brace before adjusting the up/down chain. The cutting head may fall, causing severe injury or death.

WARNING! Always secure the cutting head with a chain or a brace before adjusting the mast pads. The cutting head may fall, causing severe injury or death.

WARNING! Always secure the cutting head with a chain or a brace before removing the up/down motor belt. The cutting head may fall, causing severe injury or death.

WARNING! Drum switch grease contains Petroleum Hydrocarbon Lubricant. Eye and skin irritant. If introduced into eyes, flush with water for at least 15 minutes. If film or irritation persists, seek medical attention. Wash skin with soap and water. If ingested, do not induce vomiting - contact a physician. KEEP OUT OF THE REACH OF CHILDREN.

CAUTION! Reinstall the track wiper so that it lightly touches the track rail. If the wiper presses too firmly against the rail, it can cause the power feed to bind.

CAUTION! Never use grease on the mast rails as it will collect sawdust.

CAUTION! Do not use chain lube. It causes sawdust buildup in chain links.

CAUTION! Do not over-tension the up/down chain. Over-tensioning may lead to early failure of the gear reducer.

CAUTION! Do not overtighten the feed chain. Damage to the power feed motor may result.

CAUTION! Due to variations in the vertical mast, the pad spacing may vary throughout the travel of the saw head. Check the pad spacing at the top and bottom ends of the mast only. Pads adjusted too tight will cause premature up/down motor failure.

CAUTION! It is important that the lower stop bolts are properly

adjusted to secure the carriage on the track rail. Failure to properly adjust the stop bolts can cause saw head damage, especially during mill transportation.

CAUTION! Failure to remove sawdust buildup from the battery box lid and/or track rail cover could result in damage to these parts when the saw head is lowered to its lowest position.

See Table 1-1. Pictogram decals used to warn and inform the user about danger in the LT40.

TABLE 1-1



Decal View	W-M No.	Description
	096317	CAUTION! Read thoroughly the manual before operating the machine. Observe all safety instructions and rules when operating the sawmill.
	099220	CAUTION! Close all guards and covers before starting the machine.
	099219	Blade tension. Turning the bolt clockwise will increase the blade tension and turning the bolt counterclockwise will decrease the tension.

TABLE 1-1

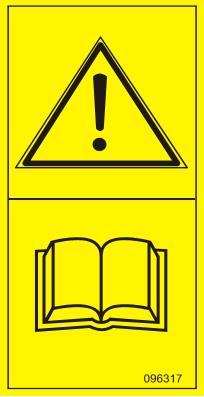

	<p>099223</p>	<p>Blade tension - See manual.</p>
	<p>099221</p>	<p>CAUTION! Keep all persons a safe distance away from work area when operating the machine.</p>
	<p>098176</p>	<p>CAUTION! Keep away from debarker blade!</p>

TABLE 1-1

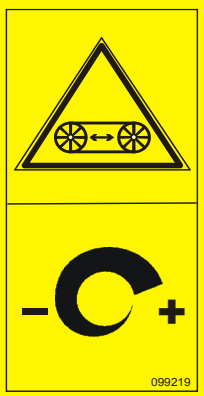
 <p>096316</p>	<p>096316</p>	<p>CAUTION! Do not open or close the electric box when the switch is not in the "0" position.</p>
 <p>096319</p>	<p>096319</p>	<p>CAUTION! Disconnect power supply before opening the box.</p>
 <p>099222</p>	<p>099222</p>	<p>CAUTION! Sawdust outlet. Protect eyes!</p>
 <p>099542</p>	<p>099542</p>	<p>CAUTION! Trailer.</p>
 <p>096321</p>	<p>096321</p>	<p>Blade movement direction</p>

TABLE 1-1

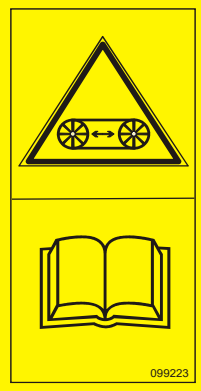





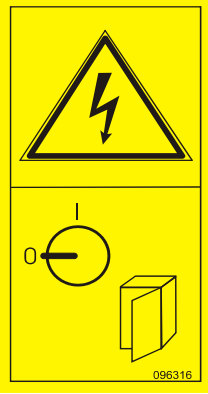
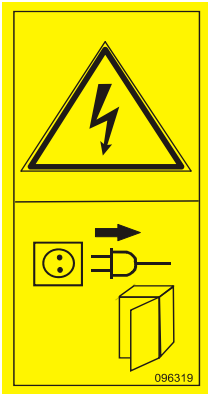
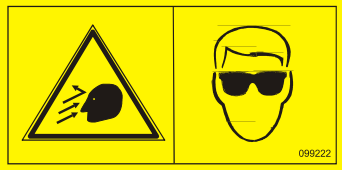
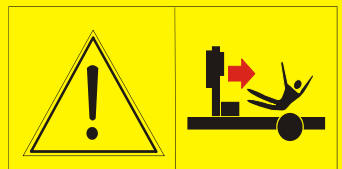
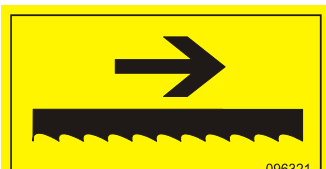

	512235	Clean chain from sawdust every 50 hours of operation or once a week
	512157	Lubricate chain every 50 hours of operation or once a week
	S12004G	CAUTION! Always wear safety goggles when operating the sawmill!
	S12005G	CAUTION! Always wear protective ear muffs when operating the sawmill!
	501465	CAUTION! Always wear safety boots when operating the sawmill
	501467	Lubrication Point

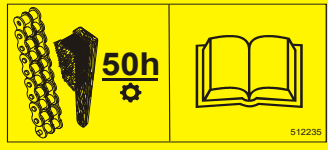
TABLE 1-1

 <p>P11789b</p>	<p>P11789</p>	<p>Aligning the blade on the wheels</p>
	<p>P85070</p>	<p>CE safety certification</p>
	<p>099401</p>	<p>Russian safety certification</p>
	<p>S20097E</p>	<p>2930 RPM - Motor rotation direction</p>

1.5 Belt Sizes

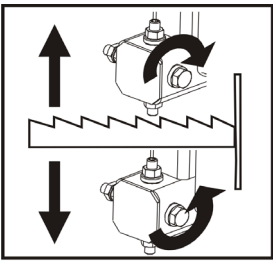
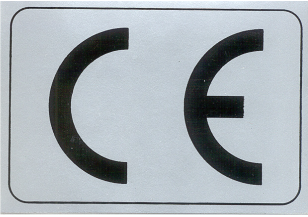
See Table 1-2. Belt sizes for the LT40 B1-4 Series are shown.

Description	Belt Size	Wood-Mizer Part #
Blade Pulley Belts	B57 ¹	P04185
Power Feed Drive Belt	AX13X1000	086532
Up/Down Drive Belt	AX23	015257
Engine Drive Belt (D42)	3BX72	014085
Alternator Belt (D42)	6PK1080	088181
Motor Drive Belt EA20 & EA25 (50Hz)	3BX73	091548

TABLE 1-2

1 Safety & General Information

Blade Sizes

¹ To insure proper blade tracking, use Goodyear, Dayco Super II, or Brown-ing belts only.

1.6 Blade Sizes

See Table 1-3. Wood-Mizer TRU•SHARP™ offers three types of blades to provide efficient sawing for all models of sawmills. The engine/motor size of your sawmill and the type of wood you saw should determine which blade you choose for optimum performance.

	Softwood ¹	Medium Hardwood	Frozen Timber or Dense Hardwood
5-15HP Gas	B275IH1030 B275IH741030	B375IH929	B375IH929 ²
7.4-11kW (10-15HP) Electric 16-25HP Gas 33HP Diesel	B376IH1030 B376IH741030	B275IH1030 B275IH741030 B376IH1030 B376IH741030 ³	B375IH929 ²
15-18.5kW (20-25HP) Electric 42HP Diesel	B376IH1030 B376IH741030	B275IH1030 B275IH741030 B376IH1030 B376IH741030 ³	B375IH929 ²

TABLE 1-3

¹ LT40 Sawmill is equipped with a blade with a length of 4.01 m.

² TRU•SHARP™ “F” blades use a 9/29 profile (9° hook angle and 29° back angle) and are designed to cut frozen and/or extremely dense, hard-to-cut wood. Standard TRU•SHARP™ blades use a 10/30 profile.

³ Customer may choose preferred blade.

LT40 Wide Sawmill is equipped with a blade with a length of 4.33 m.

See *The Blade Handbook* for blade hook angle, tooth height, and tooth set specifications.

1.7 Cutting Capacity

See Table 1-4. The log size capacities of the LT40 B1-4 series sawmill are listed below.

	Max. Diameter ¹	Max. Length ¹
LT40B1E20H	36" (91,5 cm)	3.1 m
LT40B1E20H with debarker	36" (91,5 cm)	2.8 m
LT40B2E20H	36" (91,5 cm)	5.1 m
LT40B2E20H with debarker	36" (91,5 cm)	4.8 m
LT40B3E20H	36" (91,5 cm)	7.1 m
LT40B3E20H with debarker	36" (91,5 cm)	6.8 m
LT40B4E20H	36" (91,5 cm)	9.1 m

TABLE 1-4

LT40B4E20H with debarker	36" (91,5 cm)	8.8 m
--------------------------	---------------	-------

TABLE 1-4

¹ Maximum log capacity for a basic mill is 2000 Kg.

See Table 1-5. The log size capacities of the LT40 Wide.

	Max. cutting width	Max. cant width	Max. Diameter	Max. Length
LT40 S	84 cm (33")	62 cm (24")	100 cm (39")	4,8 m (15' 7")
LT40 M	84 cm (33")	62 cm (24")	100 cm (39")	6,1 m (20')
LT40 L	84 cm (33")	62 cm (24")	100 cm (39")	8,4 m (27')

TABELA 1-5

See Table 1-6. The performance capacity of the LT40 Series sawmills is listed below. Peak cutting rates are measured in 12" (30 cm) wide red oak and represent the capability of the sawmill only. Rates based on using Tru-Sharp 1 1/2" x .045 blades.

Model	Blade speed	Cutting Rate
LT40 B1-4 Series	30 m/s	18 m/min.

TABLE 1-6

1.8 Engine/Motor Specifications

See Table 1-7. The power options available for the LT40 B1-4 Series sawmills are listed below.

Engine/Motor Type ¹	Manufacturer	Model No.	Power	Other Specifications
28HP Gasoline	Kohler	CH745	28KM	3600 RPM, 725 cm ³
42HP Diesel	Kubota	V1505-TE	42KM	4 cylinders, 1498 cm ³
33HP Diesel	Kubota	V1505-E	33KM	4 cylinders, 1498 cm ³
20HP Electric	Tamel SA, Poland	3Sg 160M-2B-HM-T Motor, Tamel	15kW (20KM)	28,1 A, 2930 RPM
25HP Electric ²	TamelSA, Poland	3Sg 160L-2-HM-T	18,5kW	33,8 A, 2930 RPM

TABLE 1-7

¹ Use diesel fuel for D42.

² The electric motors supplied on Wood-Mizer sawmills carry a rating assigned by the motor manufacturer for the continuous duty operation of the motor, potentially, 24 hours per day, day after day. This rating is useful in sizing motors for use in applications like blowers for heating and ventilation that are never cycled off except for system maintenance.

See Table 1-8. The other motors used in sawmills are listed below

Model	Manufacturer	Voltage	Rated output
Power Feed Motor controlled by ALTIVAR (Super)	Besel, Poland	3x400V	1,1 kW, 1380 RPM
Up/Down Motor (2-Speed, Super only)	Besel, Poland	3x400V	0,55/0,9 kW, 950/1400 RPM
Blade Guide Arm Motor	Motor Products Owosso, USA	12V	17W, 60 RPM

TABLE 1-8

See Table 1-9. See the table below for power supply specifications for the LT40 sawmill

	3-Phase Volts	Fused Disconnect Switch	Recommended Wire Size
15kW (EA20)	400 VAC	32 A	6 mm ² up to 15 m of length
18,5kW (EA25)	400 VAC	40 A	6 mm ² up to 15 m of length

TABLE 1-9



DANGER! It is recommended that a 30mA Ground Fault Interrupter (GFI) be used.

1.9 Noise Level

See Table 1-10. The average noise level is given in the table below¹².

Sawmill	Noise Level L_{EX8}
LT40AE15H	77,1 dB (A)
LT40AE20H	78,0 dB (A)
LT40AE25H	86,2 dB (A)
LT40 sawmill equipped with Diesel engine	87.7 dB (A)

TABLE 1-10

-
1. The noise level measurement was taken in accordance with PN-EN ISO 3746 Standard. The noise exposure level given above concerns an 8-hour work day
 2. The measured values refer to emission levels, not necessarily to noise levels in the workplace. Although there is a relation between emission levels and exposure levels, it is not possible to determine with certainty if preventives are needed or are not needed. The factors affecting a current level of noise exposure during work are inter alia room characteristics and characteristics of other noise sources, e.g. number of machines and machining operations nearby. Also, the permissible exposure level value may vary depending on country. This information enables the machine's user to better identify hazards and a risk.

1.10 Overall Dimensions

See Table 1-11. The overall dimensions of the Wood-Mizer LT40 B1-4 Series sawmills are listed below.

Model	Length ¹	With (Operating Position with Loading Arms)	Height ²	Weight ³
LT40B1	4.35 m	8' 2" (2.5 m)	7' 8" (2.4 m)	3291 lbs. (1481 kg)
LT40B2	6.35 m	8' 2" (2.5 m)	7' 8" (2.4 m)	3291 lbs. (1481 kg)
LT40B3	8.35 m	8' 2" (2.5 m)	7' 8" (2.4 m)	3291 lbs. (1481 kg)
LT40B4	10.35 m	8' 2" (2.5 m)	7' 8" (2.4 m)	3491 lbs. (1571 kg)

TABLE 1-11

¹ Length from hitch to chain bracket.

² Height from ground to mast. Placing head in maximum position will add to total height.

³ Weight will increase when sawmill will be equipped with additional accessories, like Remote or debarker.

1.11 Chains

See Table 1-12. The load capacity of the chains is listed below.

	Load Capacity According to ISO Nr 08A-1
Power Feed Chain	1780N
Up/Down Chain	1780N

TABLE 1-12

1.12 Hydraulic System

See Table 1-13. The specifications of the hydraulic system are shown below.

Hydraulic Pump	HYDROIRMA
Pressure Rating	15MPa

TABLE 1-13

1.13 Dust Extractor Specifications

See Table 1-14. Specifications of the dust extractors used on the resaw for each saw head are listed below.¹

Airflow	1200 m ³ /h 3937ft ³ /h
Inlet diameter	100 mm (5.9")
Motor power	1,5 kW
Number of sacks	1 pcs
Sack capacity	0,25 m ³ (8.8 ft) ³
Weight	110 kg (242.5 lb)
Pressure drop	1,5 kPa (0.22 psi) ¹
Recommended conveying air velocity in the duct	20 m/s 65.6 ft/s

TABLE 1-14

¹ The pressure drop between the inlet of the capture device and the connection to the CADES should be maximum 1,5 kPa (for the nominal air flow rate). If the pressure drop exceeds 1,5 kPa the machine might not be compatible with conventional CADES.



IMPORTANT! The dust extractor hoses must be grounded or made with materials not accumulating electrostatic charge.



CAUTION! Always turn on the dust extractor before starting the machine



IMPORTANT! The total value of hand-arm vibration the operator may be exposed to does not exceed 2.5 m/s². The highest root mean square value of weighted acceleration to which the whole operator's body is subjected does not exceed 0.5 m/s².

1. External chip and dust extraction equipment with fixed installations are dealt with in EN 12779:2016-04

1.14 Components

See Figure 1-1. The major components of the LT40 B1-4 sawmill are shown below.

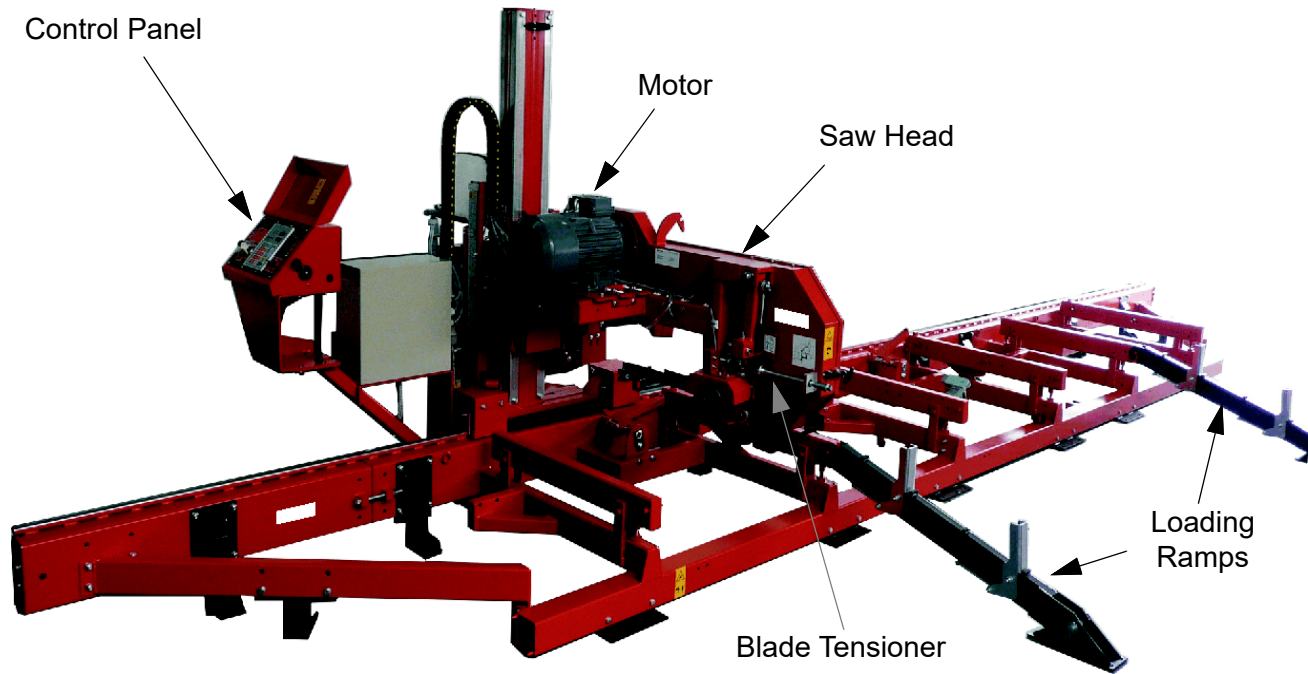

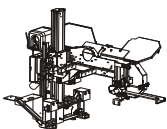

FIG. 1-1

SECTION 2 SAWMILL ASSEMBLY

2.1 Mounting Parts of LT40 Sawmills

2.1.1 Specifications of Parts

Table 1:

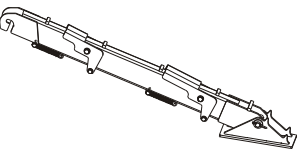
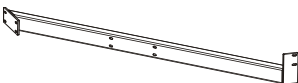
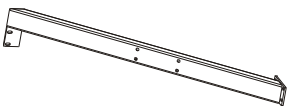
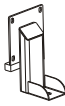
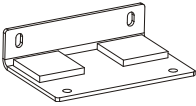
Fig.	Wood-Mizer Part No.	Description	Qty LT20B3
	503630	Sawmill Saw Head	1
	093012	D33 Motor Kit	1
	093006	E20 Motor Kit	1
	100634	Log Ramp (Optional Equipment)	2
	100551-1	Side Tube, Front	1
	100545-1	Side Tube, Back	1
	100536-1	Leg, Long (non-adjustable legs kit)	7
	100550-1	Leg, Short (non-adjustable legs kit)	6

2 SAWMILL ASSEMBLY

Specifications of Parts

Table 1:







	100868-1	Leg, Side (non-adjustable legs kit)	2
	101186-1	Leg, Long with Tube (non-adjustable legs kit)	1
	099281-1	Foot Assembly (adjustable legs kit)	16
	100553-1	Leg, Short (adjustable legs kit)	6
	100554-1	Leg, Side (adjustable legs kit)	2
	100559-1	Leg, Long (adjustable legs kit)	7
	101187-1	Leg, Long with Tube (adjustable legs kit)	1
	500775-1	Leg, Wide (adjustable legs kit)	8
	099728-1	Bed Extension, LES	2
	087105-1	Bumper Bracket	1
	091828	Bumper	1

Table 1:

	015023	Cover	1
	510230	Clamp, Complete	Depends on order
	100903-1	Sawdust Chute Weldment	1
	100999	Tube, Sawdust Chute Rubber	1
	089712-1	Bumper Bracket	1
	091852-1	Limit Switch Bracket	1

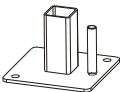
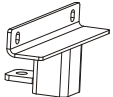
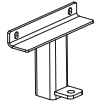
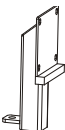
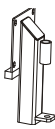
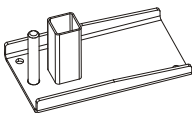
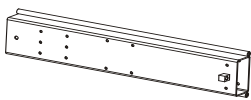
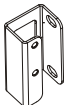
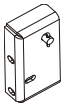
2.1.2 Specifications of Fasteners

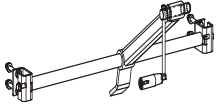
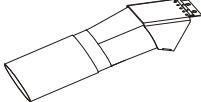
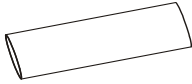
Table 2:

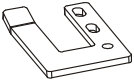
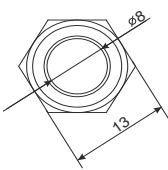
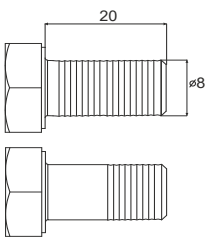
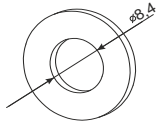
Wood-Mizer No.	Description	Qty. LT20B3
Sample designations of fasteners: <div style="display: flex; justify-content: space-around; align-items: flex-start;"> <div style="text-align: center;"> <p>M8 Nut</p>  </div> <div style="text-align: center;"> <p>M8x20 Bolt</p>  </div> <div style="text-align: center;"> <p>8.4 Washer</p>  </div> </div>		
F81036-1	NUT, M16-5.8 HEX ZINC	36
F81055-1	WASHER, 10.5 FLAT ZINC	56
F81033-1	NUT, M10-8-B HEX NYLON ZINC LOCK	44
F81003-33	BOLT, M10X120 8.8 CARRIAGE ZINC	24
F81003-18	BOLT, M10 X 125-8.8 HEX HEAD ZINC	8
F81003-15	BOLT, M10x75-8.8 HEX HEAD ZINC	4
F81058-1	WASHER, 17 FLAT ZINC	42
F81056-1	WASHER, M12 FLAT ZINC	26
F81034-2	NUT, M12-8 HEX NYLON ZINC LOCK	2
F81034-1	NUT, M12-8-B HEX ZINC	2
F81006-23	BOLT, M16X160-8.8 HEX HEAD ZINC	4
F81004-55	BOLT, M12X130-8.8 HEX HEAD ZINC	4
F81004-45	BOLT, M12X100-8.8 HEX HEAD ZINC	2
F81004-12	BOLT, M12X55-8.8 HEX HEAD ZINC	4
F81003-34	BOLT, M10X125 CARRIAGE	8

2.1.3 Tools Necessary for Assembling the Sawmill**Table 3:**

Required Tools	
Flat Wrench #8	1 pc
Flat Wrench #10	2 pcs
Flat Wrench #13	2 pcs
Flat Wrench #17	2 pcs
Flat Wrench #19	2 pcs
Ratchet Wrench #30	1 pc
Hammer	1 pc
Allen Wrench #4	1 pc
Allen Wrench #5	1 pc

2 SAWMILL ASSEMBLY

Unpacking the Sawmill

2.2 Unpacking the Sawmill



IMPORTANT! The machine can be lifted with a forklift only. Use a forklift with lifting capacity of minimum 2000kg and forks at least 2m long.

2.2.1 *Standard Version of the Sawmill*



FIG. 2-0

2.2.2 Sawmill with Remote Equipment

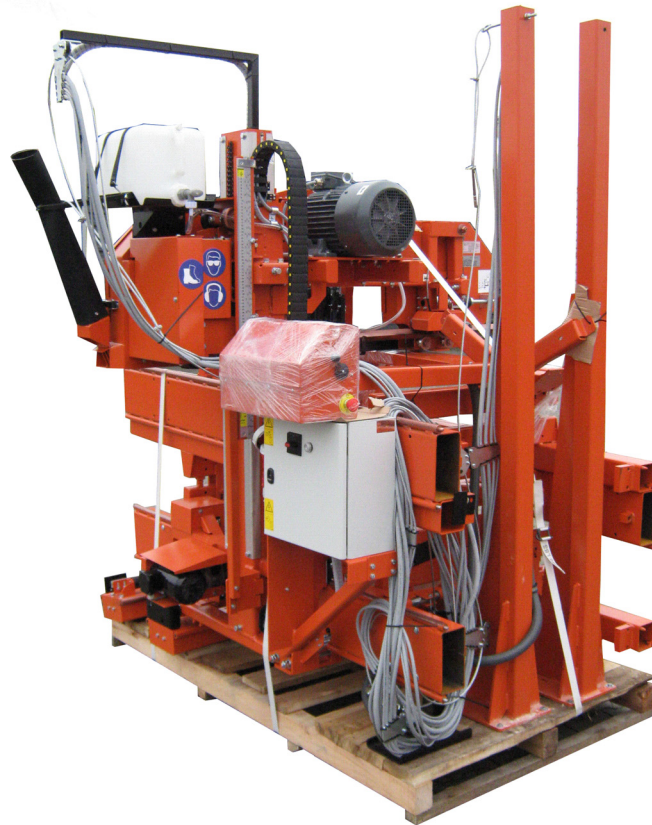

FIG. 2-0

1. Cut the bands holding the components together.
2. Remove the parts which are placed on the box. Next remove the parts from inside of the box. Remove the box from the pallet.
3. Plug the power cord, turn the main power switch to the ON position. Switch the key to the "M" position. Press the START button to start the blade motor for the moment. Then stop the motor and check if the motor rotations are in accordance with the arrow on the motor cover.



IMPORTANT! When starting the machine for the first time, check that main motor rotation direction is as indicated by the arrow located on the motor body (fan guard). If the rotation direction is incorrect, invert the phases in the phase inverter located in the power socket (electric box). Setting the phases in the phase inverter correctly will ensure

correct rotation directions of all sawmill motors.

4. Carefully raise the cutting head by about 20 cm.
5. Turn the key switch to the “0” position. Turn the main power switch to the OFF position and disconnect the power cord.
6. Using a forklift truck with lifting capacity of at least 1000 kg, carefully lift the two bed sections from the pallet.
7. Plug the power cord again, turn the main power switch to the ON position. Switch the key to the “M” position and lower the cutting head completely. Then turn off power and disconnect the power cord.
8. Lift the last bed section with the saw head.



WARNING! When lifting the bed sections, especially the bed section with the saw head, use extreme care and keep all persons at a safe distance. Failure to do so may result in serious injury or death.



IMPORTANT! When the saw head with bed section is taken off the pallet, remove two short legs and mount them as shown on the picture, [See Section 2.3](#).

2.3 Bed Frame Assembly



IMPORTANT! With all screw joints without split lock washer or lock nylon nut, use the "LOCTITE 243" (blue, of average durability, for screw joints).

1. Mount the legs to each bed section as shown below.

See Figure 2-1. Non-adjustable legs are shown below.

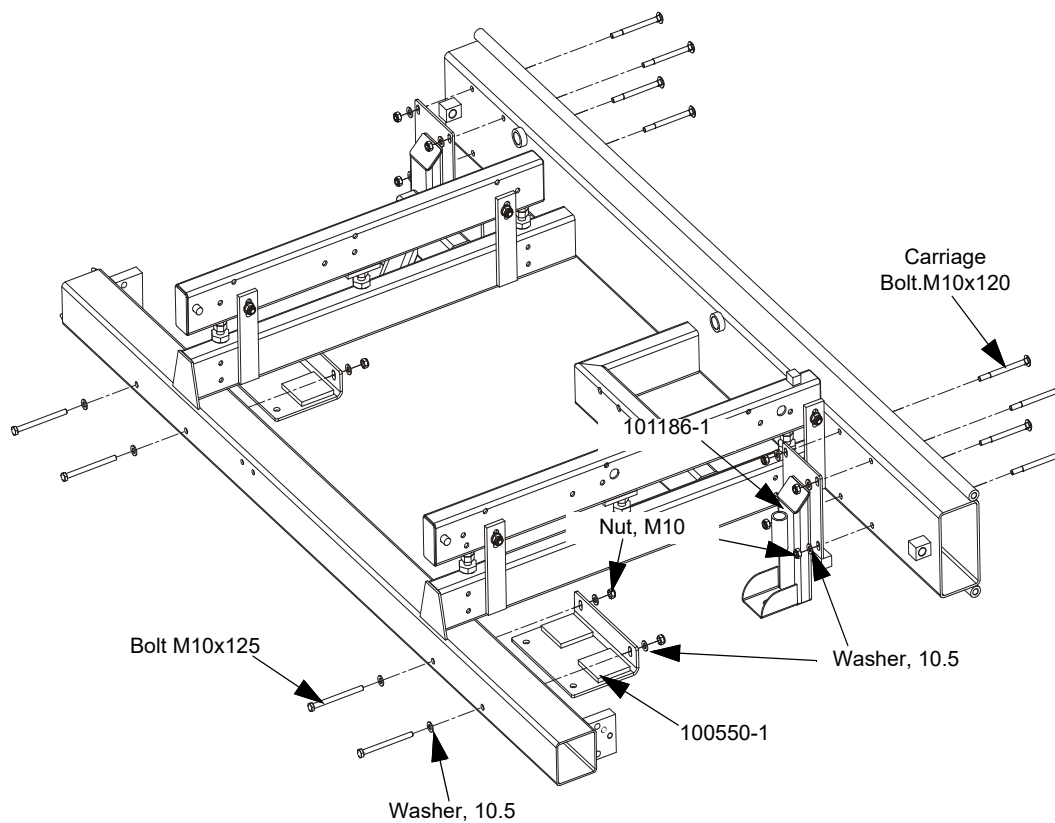

FIG. 2-1

2 SAWMILL ASSEMBLY

Bed Frame Assembly

See Figure 2-2. Adjustable legs are shown below.

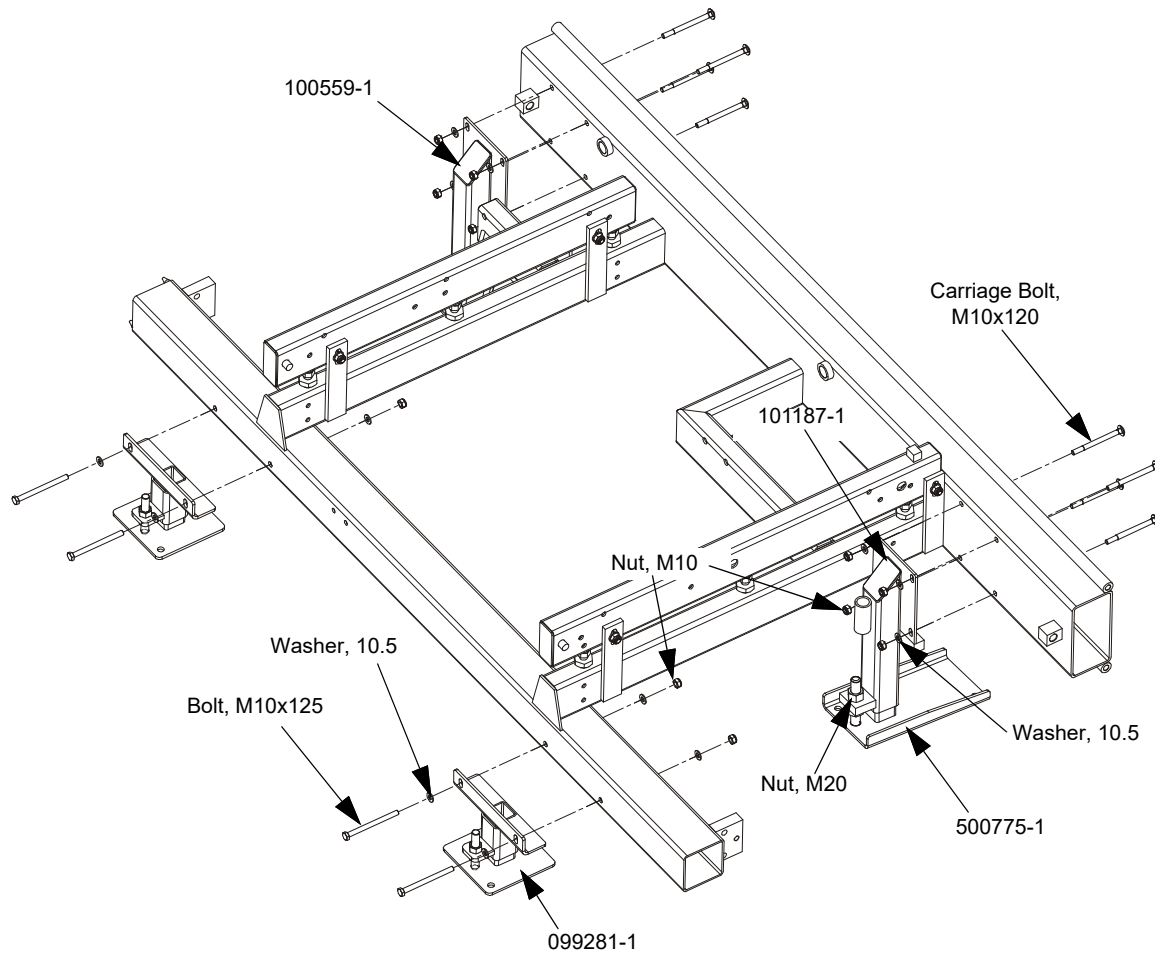

FIG. 2-2

2. Mount the bed segments together.

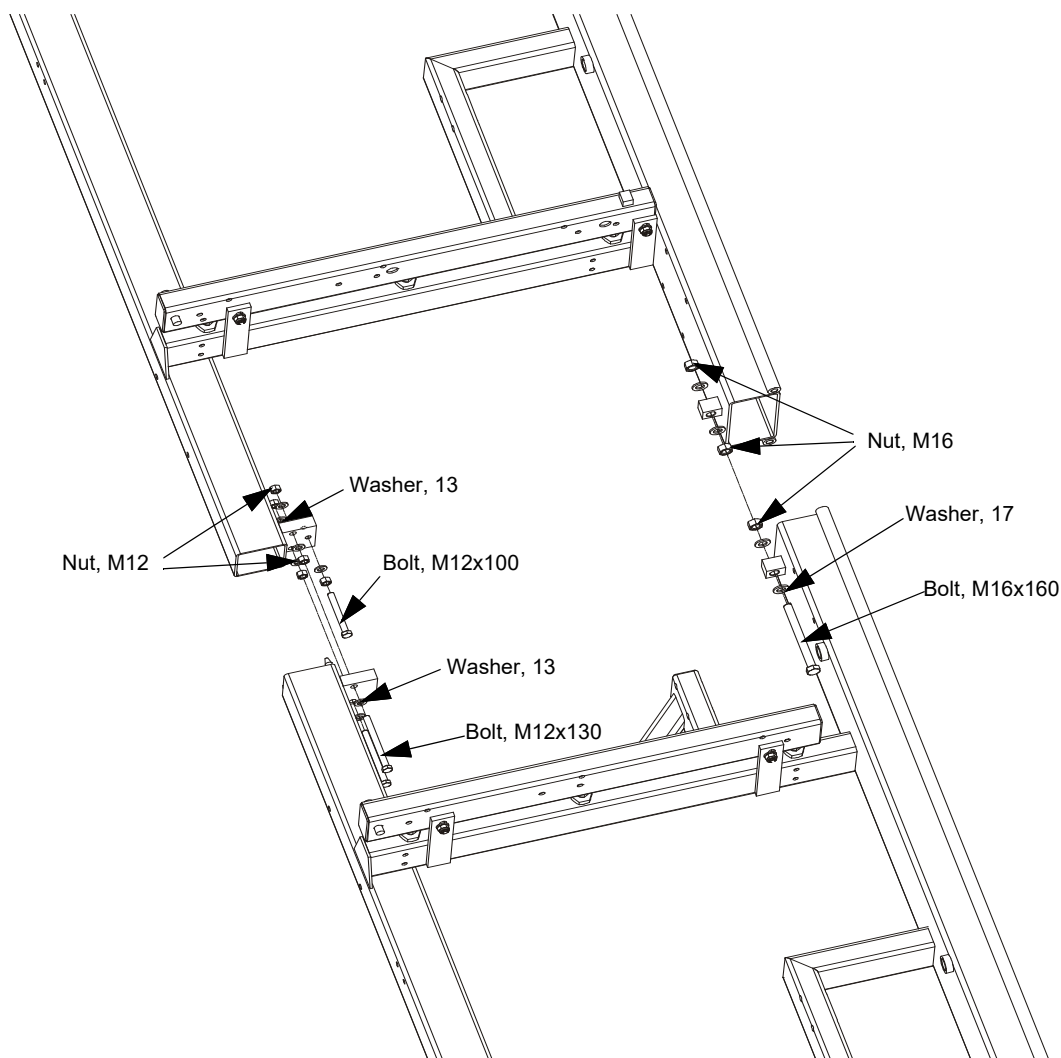

FIG. 2-2

3. Align the bed sections.

Put the flat bar against the upper track rail and check if it touches the rail along its entire length. If there is a gap in the middle of the bar, you need to screw in the adjustment bolt and tighten the mounting bolt. If there is a gap at one end of the bar, you need to loosen the mounting bolt and unscrew the adjustment bolt.

Repeat the above procedure on each segment connection (depending on the number of sections used).

2 SAWMILL ASSEMBLY

Bed Frame Assembly

See Figure 2-3.

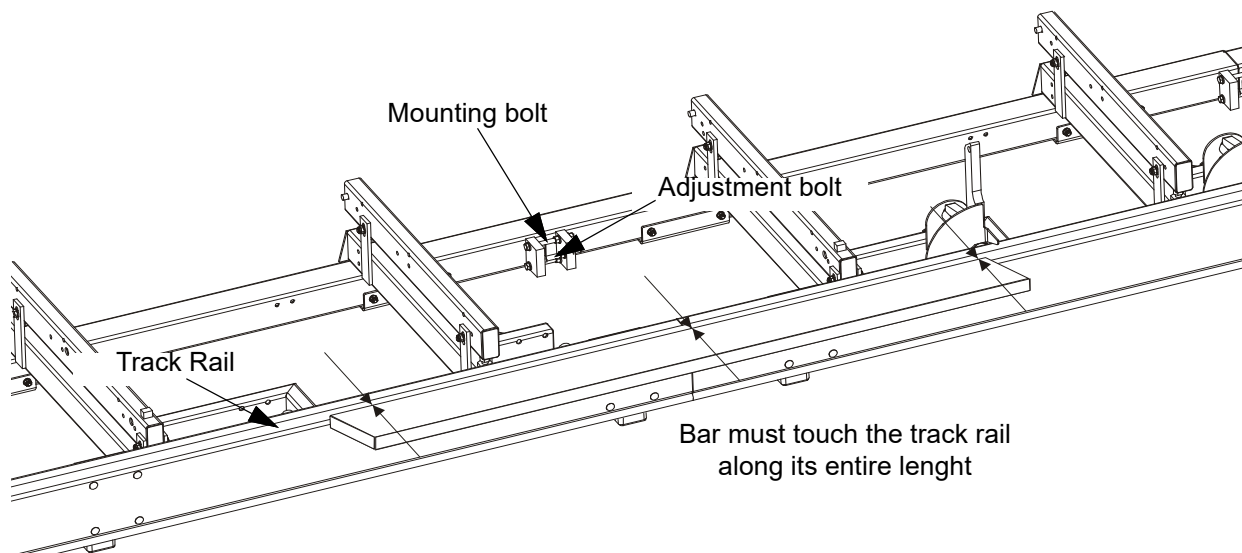

FIG. 2-3

Next place the bar on the top of the upper track rail. The bar must touch the rail along its entire length. If there is a gap in the middle of the bar or at its end, you need to put wedges under segment legs (frame with non-adjustable legs) or adjust the legs to raise the appropriate end of the segment (frame with adjustable legs).

See Figure 2-4.

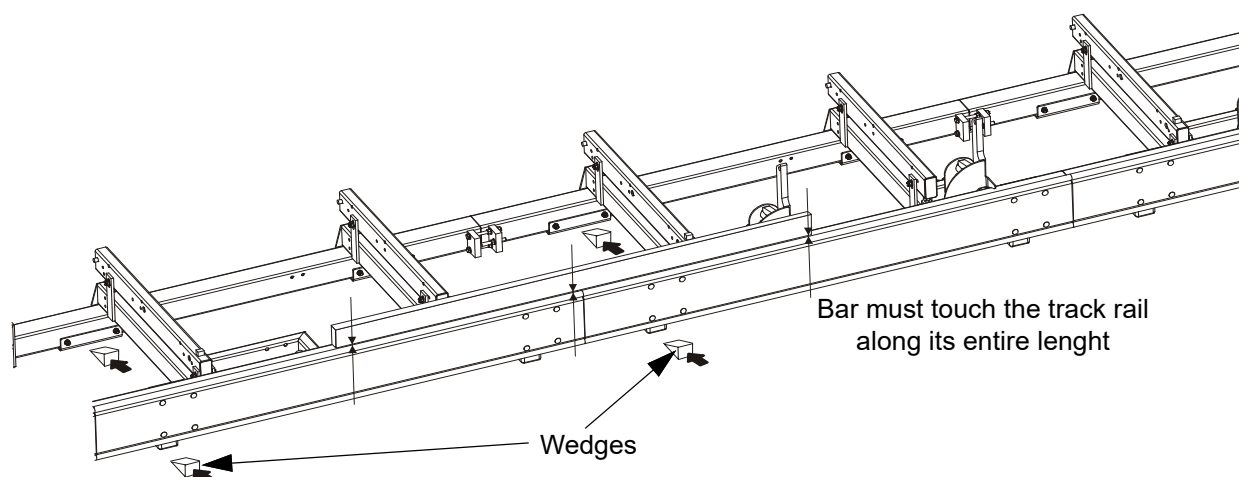

FIG. 2-4

4. Mount the bed extensions.

Mount the legs to the bed extensions. Next mount the main tube of the bed extension and the supporting tube together. Mount the complete bed extension to the sawmill frame.

See Figure 2-5.

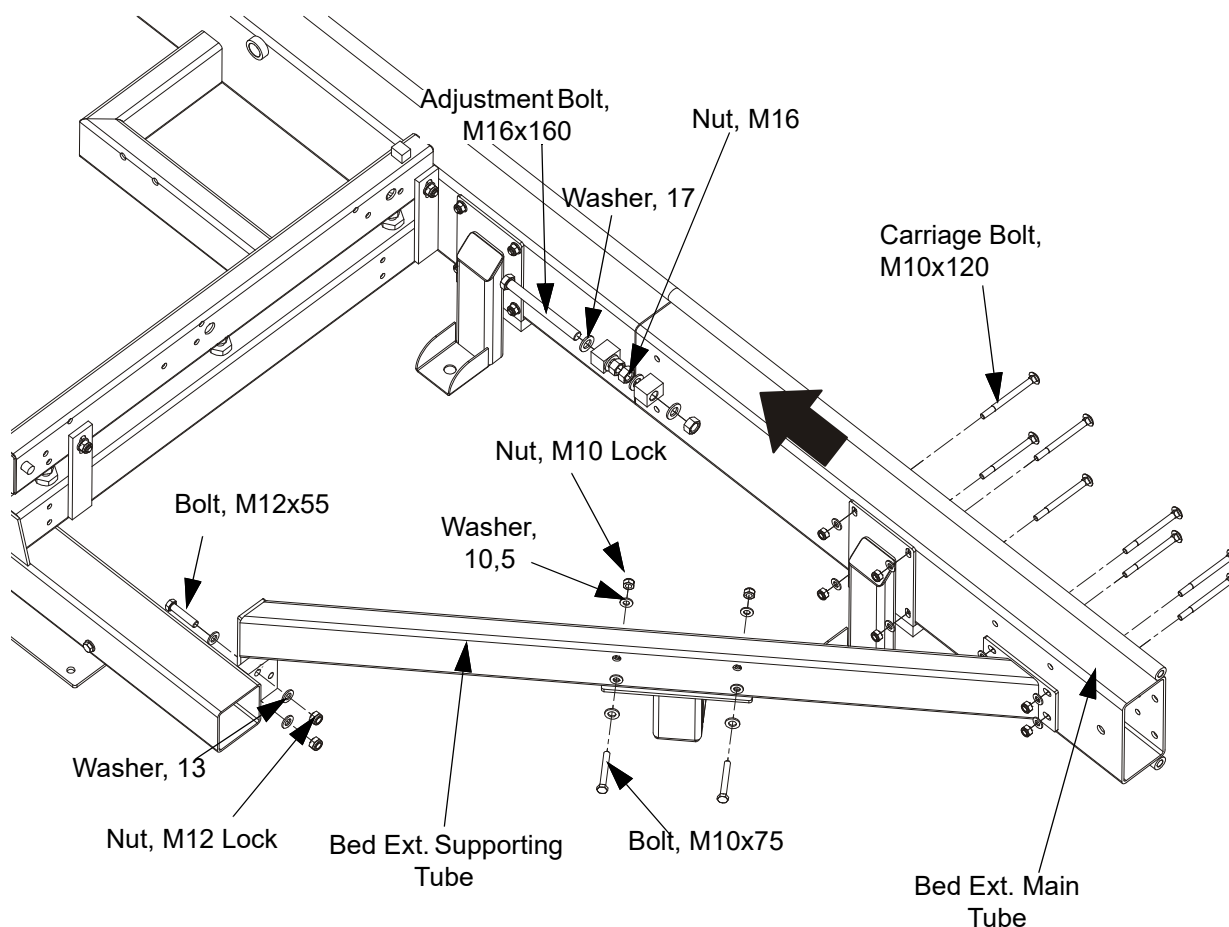

FIG. 2-5

5. Align the bed extension with the sawmill frame. Put the flat bar against the upper track rail and check if it touches the rail along its entire length. If there is a gap at one end of the bar, you need to tighten the adjusting bolt.

2 SAWMILL ASSEMBLY

Bed Frame Assembly

See Figure 2-6.

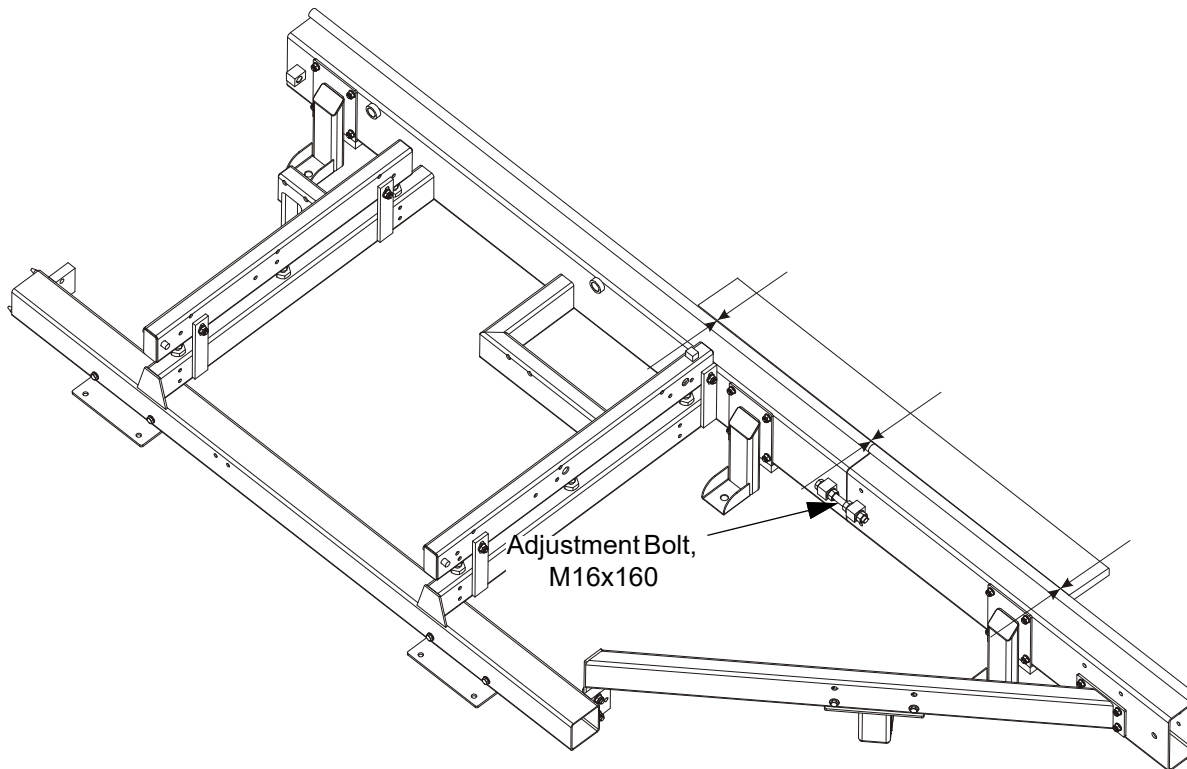

FIG. 2-6

6. Mount the saw head front bumper with the bracket and the main tube cover.

See Figure 2-7.

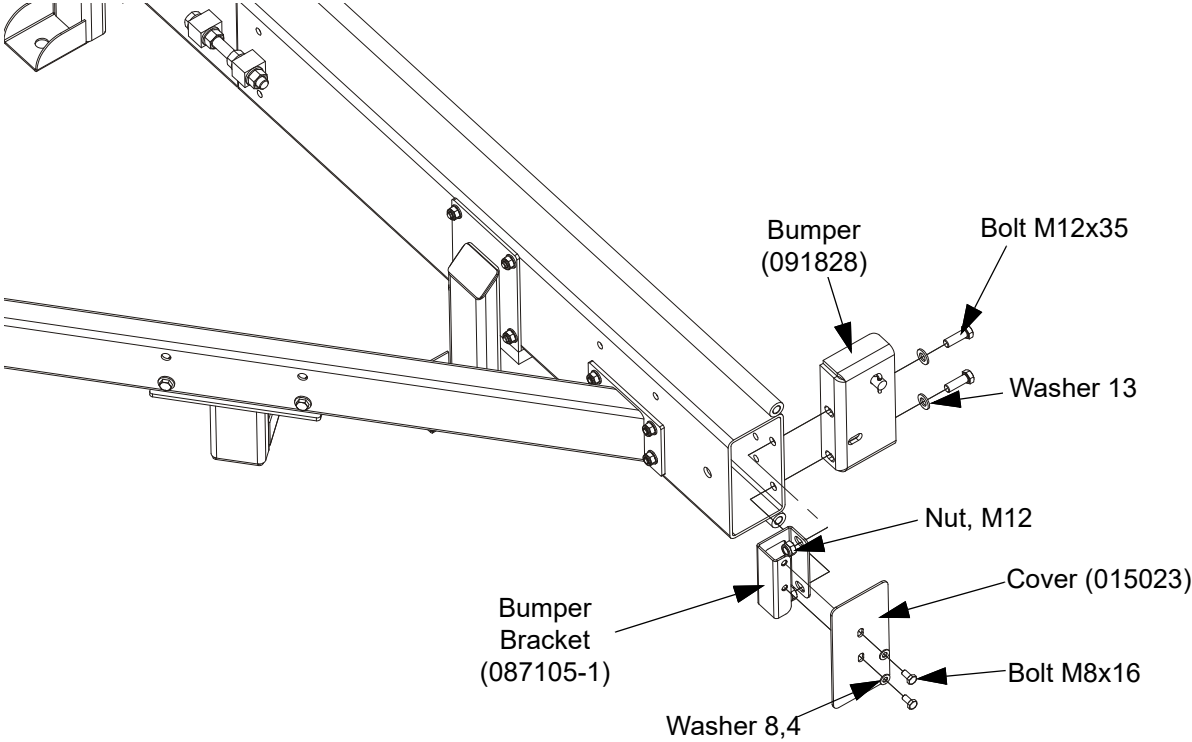

FIG. 2-7

7. Mount the rear bumper.

2 SAWMILL ASSEMBLY

Bed Frame Assembly

See Figure 2-8.

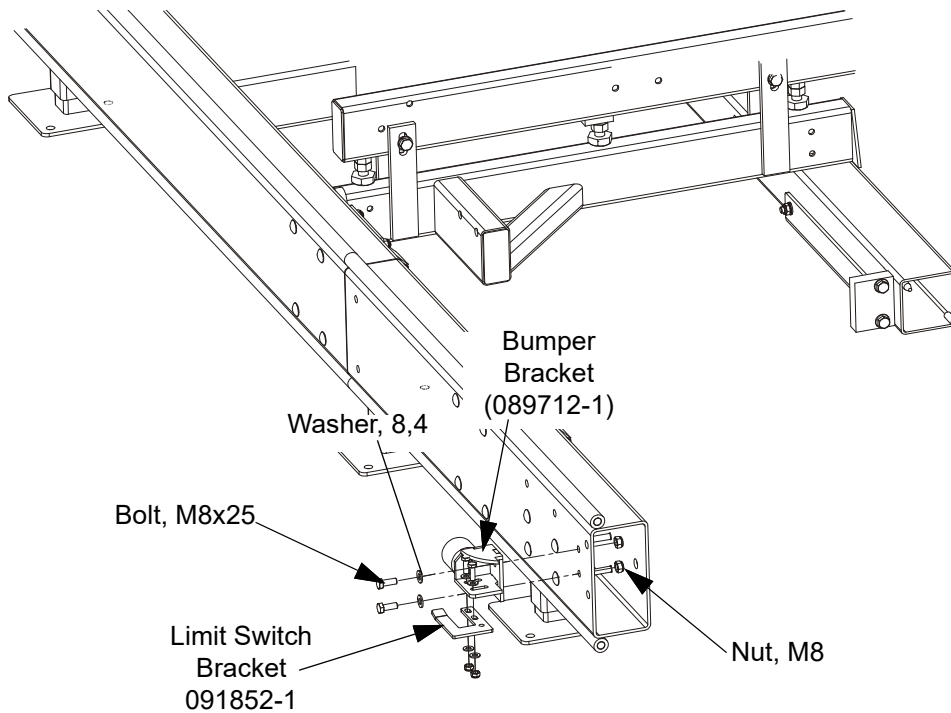

FIG. 2-8

8. Mount the side tube with the leg.

See Figure 2-9.

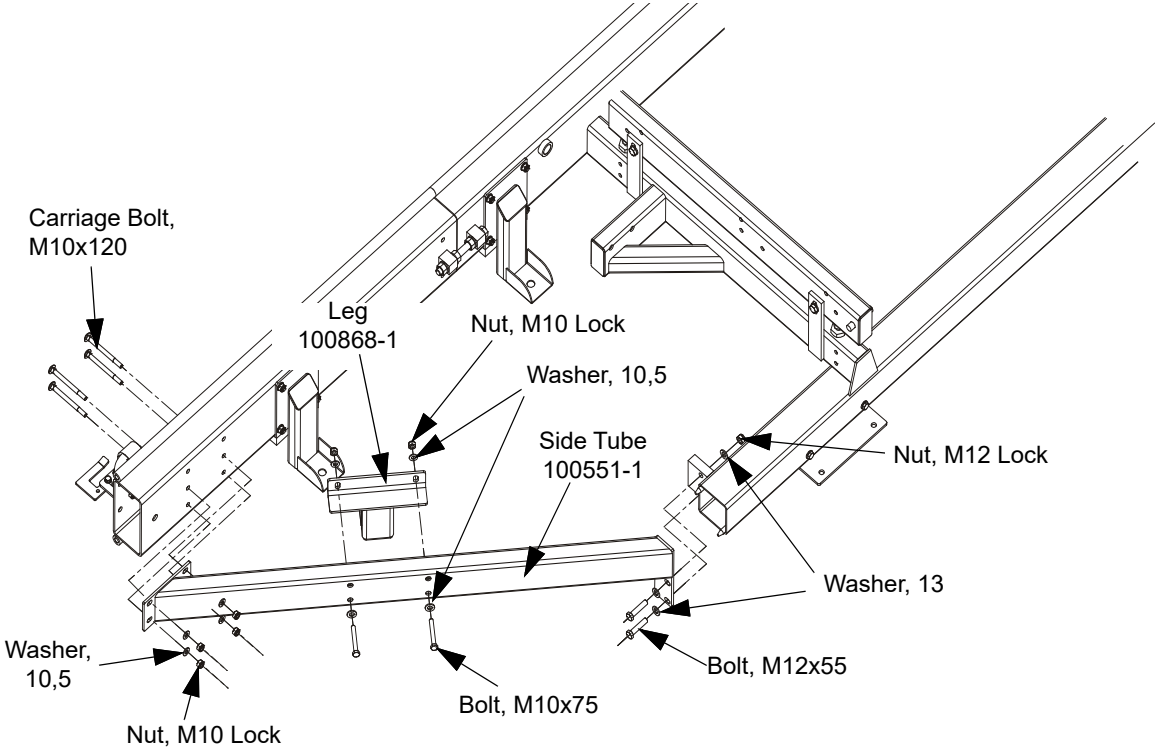

FIG. 2-9

9. Mount the log clamp.

2 SAWMILL ASSEMBLY

Bed Frame Assembly

See Figure 2-10.

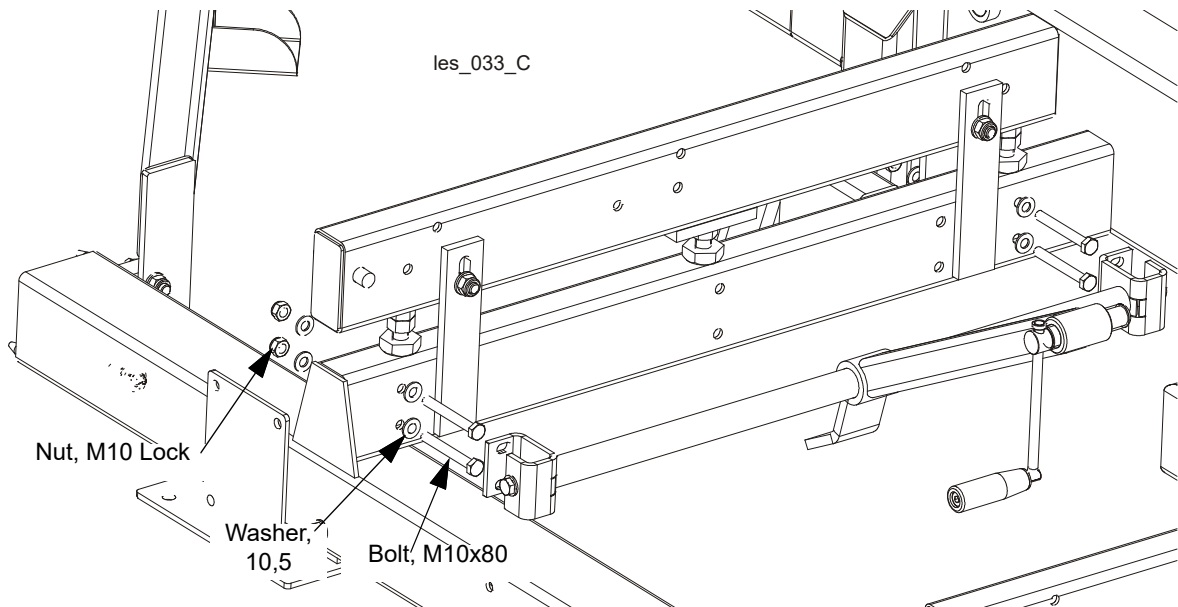

FIG. 2-10

10. Mount the sawdust chute.

See Figure 2-11.

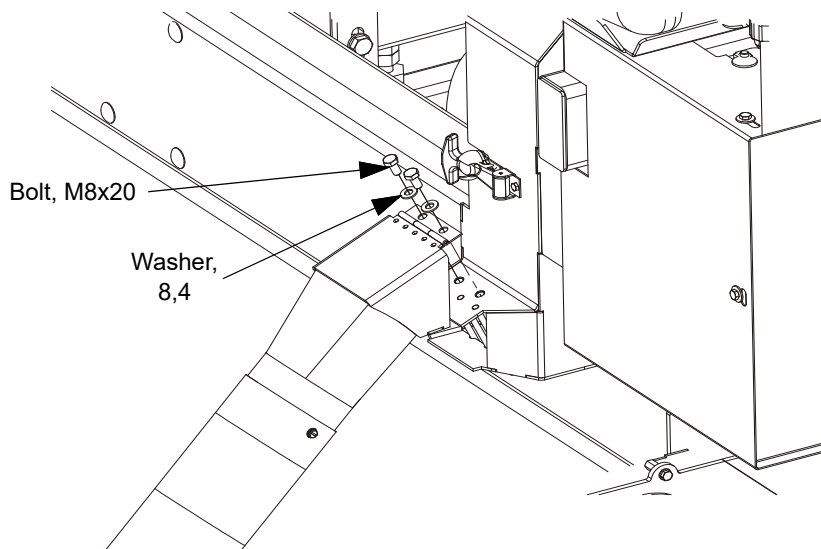

FIG. 2-11

11. Mount the power cord bracket.

See Figure 2-12.

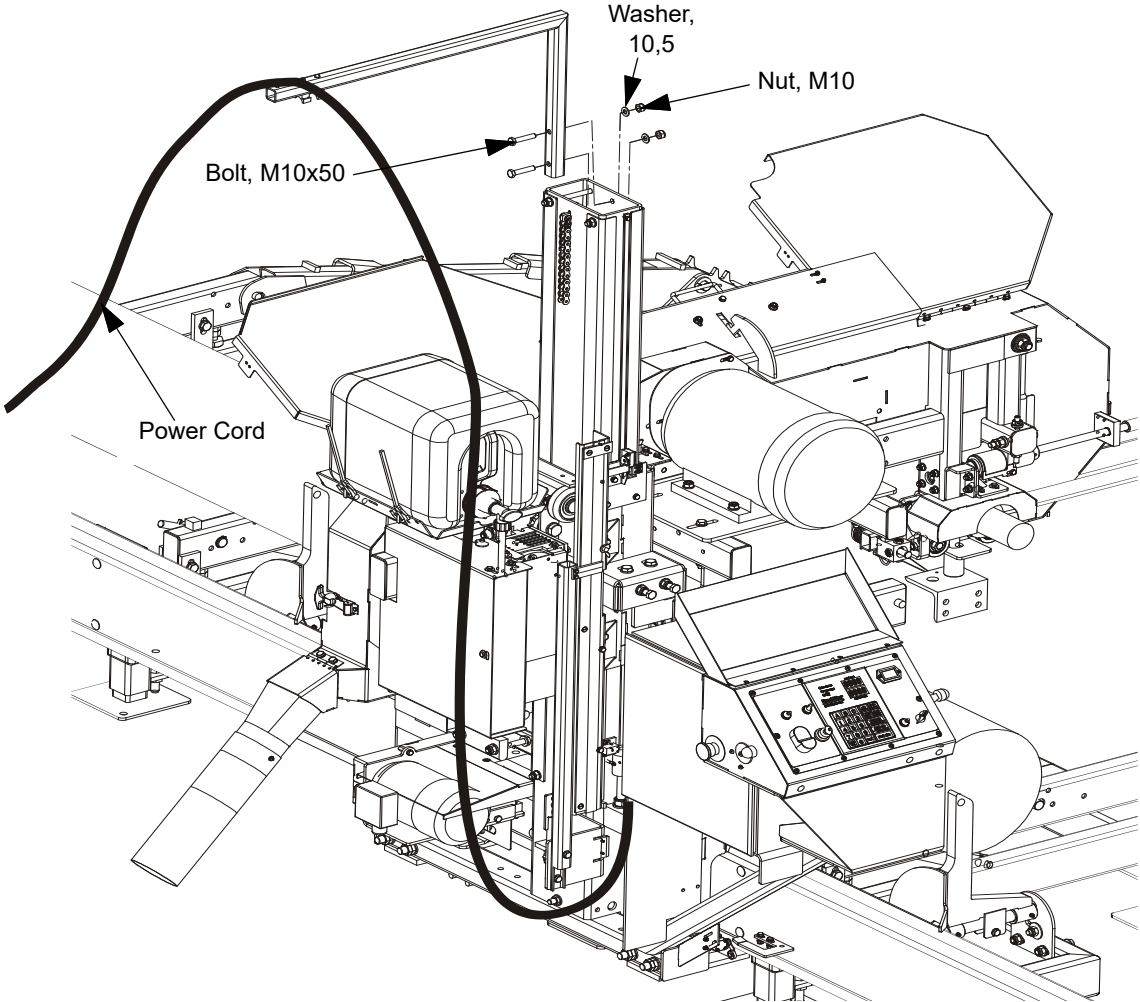

FIG. 2-12

12. Mount the log ramps (optional equipment).

2 SAWMILL ASSEMBLY

Bed Frame Assembly

See Figure 2-13.

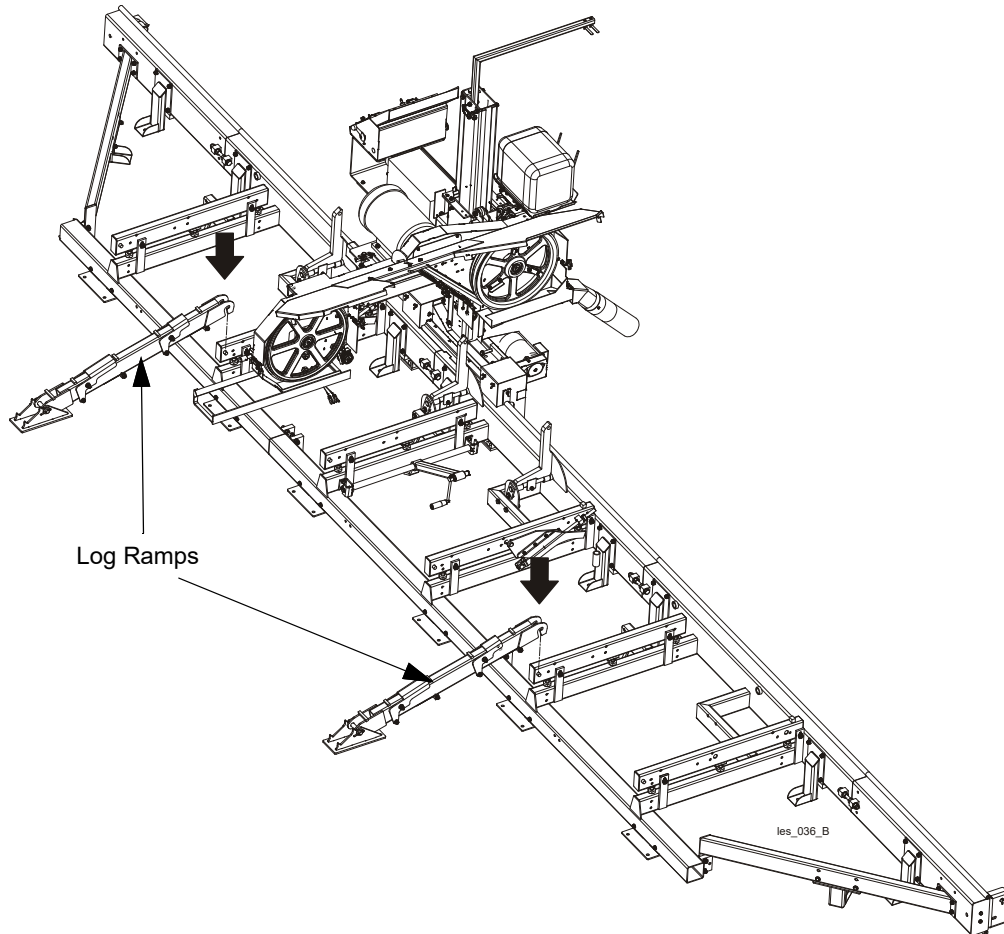

FIG. 2-13

SECTION 3 SETUP & OPERATION

3.1 Sawmill Setup



IMPORTANT! Before starting to use the sawmill you have to meet the following conditions:

- Set up the sawmill on firm and level ground.
- The sawmill can be operated with the sawdust collection system only.
- The sawmill can be operated under roof only.
- The sawmill can be operated in temperature range from -15° C to 40° C only.
- Illumination at operator's position must be 300lx.
- Have a qualified electrician install the power supply (according to EN 60204 Standard). The power supply must meet the specifications given in the table below.

3-Phase Volts	Fuse disconnect	Suggested Wire Size
400 VAC	40 A	6 mm ² up to 15 m long

TABLE 3-1



IMPORTANT! When starting the machine for the first time, check that main motor rotation direction is as indicated by the arrow located on the motor body (fan guard). If the rotation direction is incorrect, invert the phases in the phase inverter in the power socket (electric box). Setting the phases in the phase inverter correctly will ensure correct rotation directions of all sawmill motors.

3.1.1 *Setting up sawmills equipped with non-adjustable legs*

Set up the mill on firm and level footing. Fasten the mill to the floor to prevent any creep after prolonged use. A cement pad with 5/8" (16 mm) diameter anchor bolts is recommended. The cement pad should be rated to support 6350 lbs./sq.ft. (31 T/m²) at each sawmill foot position.



WARNING! Do not operate a sawmill without the feet securely fastened to the floor.

from tipping over.

- 13. After mounting the segments together, level the sawmill frame using the outrigger legs.

See Figure 3-2.

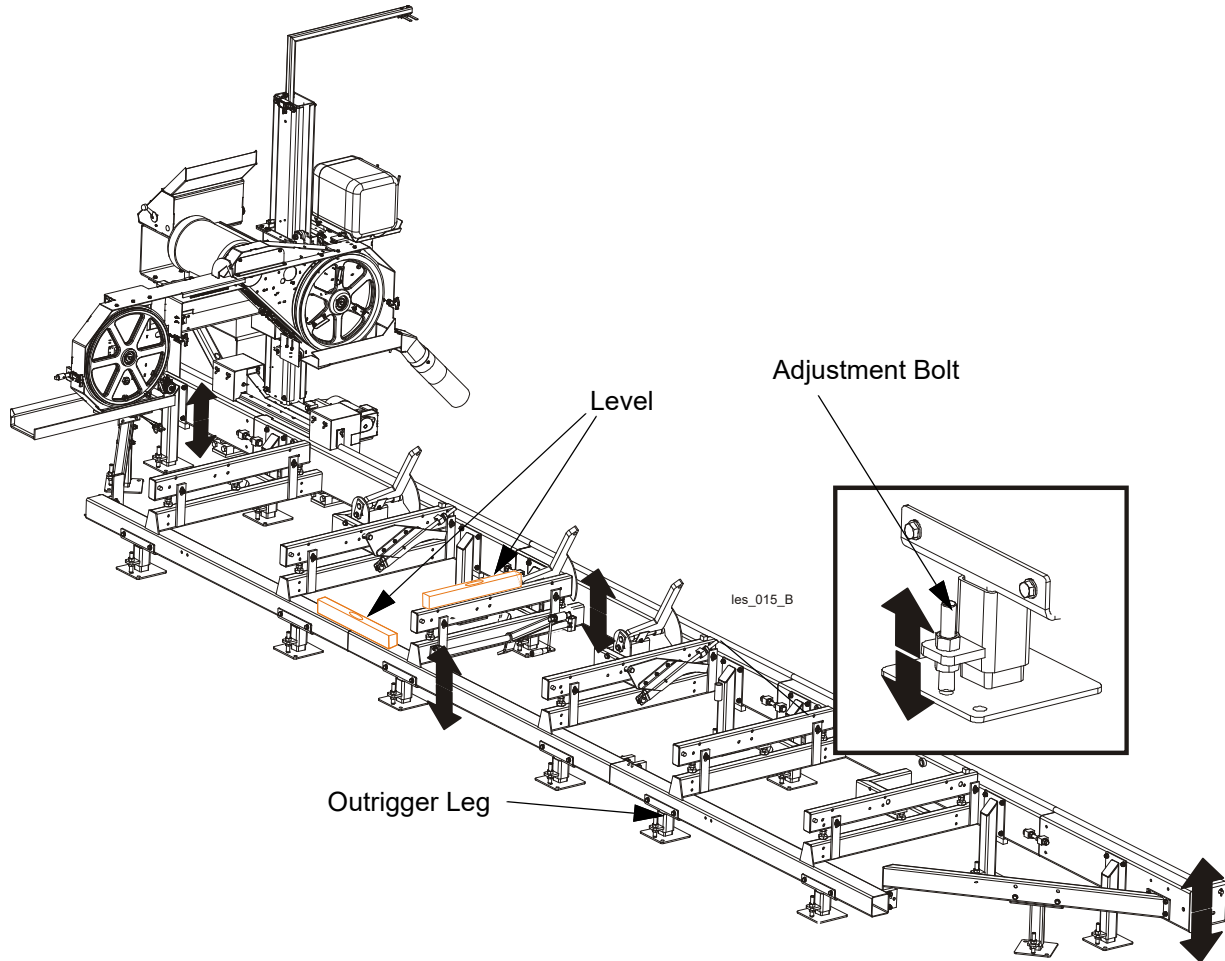

FIG. 3-2. OUTRIGGER ADJUSTMENT

3 SETUP & OPERATION

Setting up sawmills equipped with outrigger legs

See Figure 3-3.

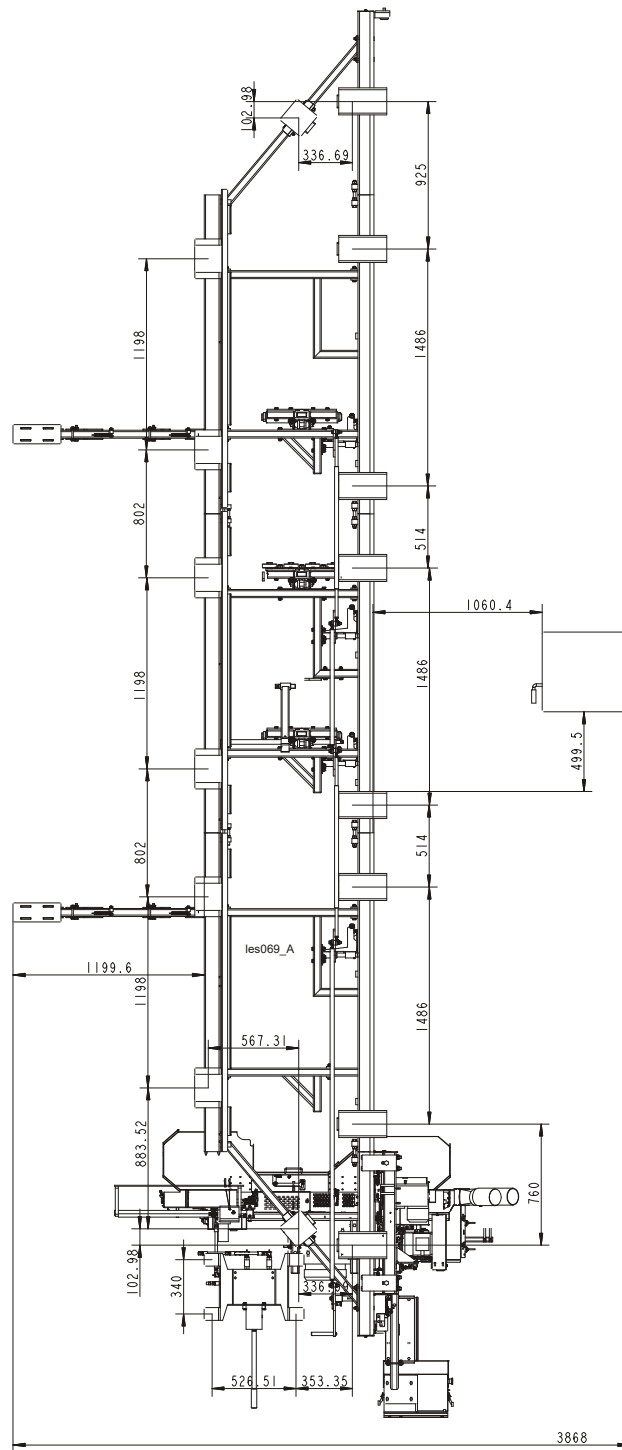

FIG. 3-3. OUTRIGGER PLACEMENT (H1, H2, H3 HYDRAULIC)



CAUTION! When setting up the sawmill on boggy terrain (such as deep mud or sand), place a board or a metal plate under each outrigger leg to prevent the legs from sinking.

NOTE: Make sure the unit is level before securing. The sawmill mast should not be tilted from the vertical more than 3° towards the loading ramps. The mast should not be tilted in the opposite direction.

14. Unhook the carriage safety chain, located at the bottom of the vertical mast.
15. Use the up/down crank or the up/down switch to raise the cutting head from the carriage rest pin. Swing the rest pin below bed level.
16. Use the power feed switch to move the cutting head toward the front end of the mill. Raise the two side supports that will prevent a log from falling off the side of the mill when loaded.

See Figure 3-4.

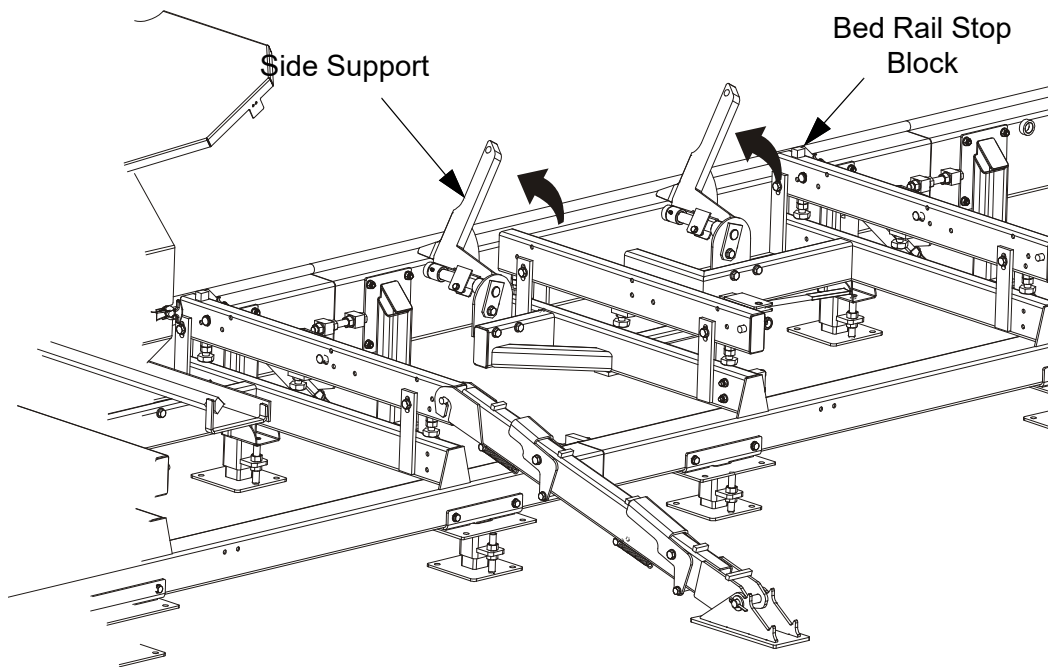

FIG. 3-4

3.2 Sawmills with cable guide

See Figure 3-5. The figure below shows setup of the sawmill, the control box and the guiding rail columns.

Secure the columns to the ground using 16mm anchored bolts.

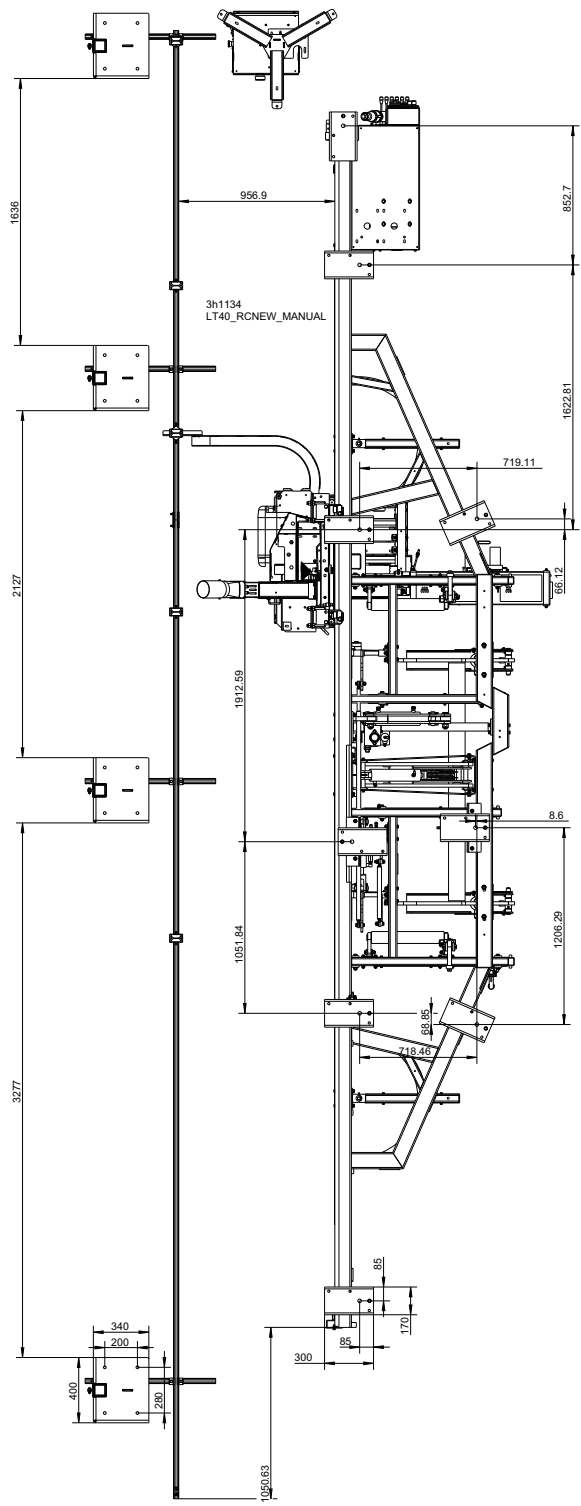

FIG. 3-5 LT40MRC

See Figure 3-6. The electrical wires should be installed on the guiding rail as shown below.



FIG. 3-6

See Figure 3-7. Install the rail bracket arm as shown below.

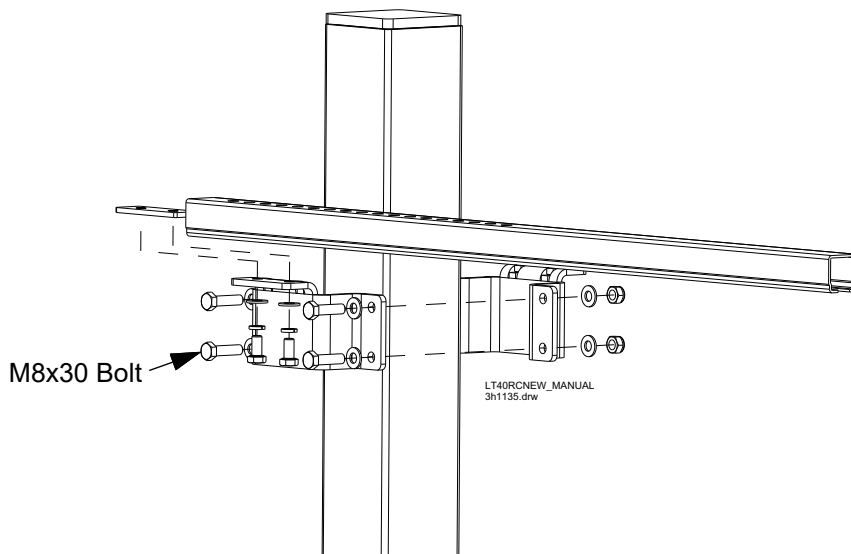

FIG. 3-7

See Figure 3-8. Install the guiding rail.

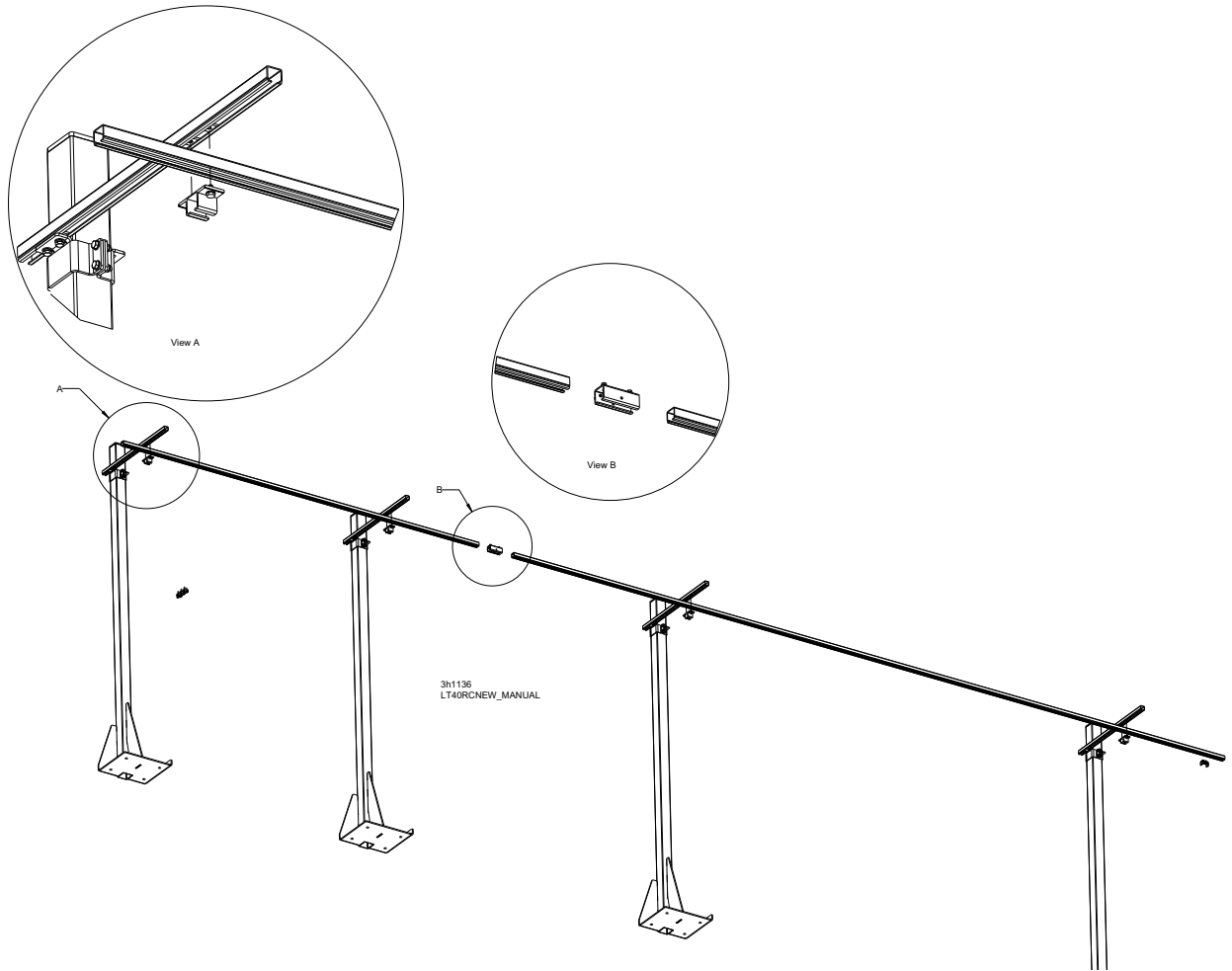

FIG. 3-8

See Figure 3-9.

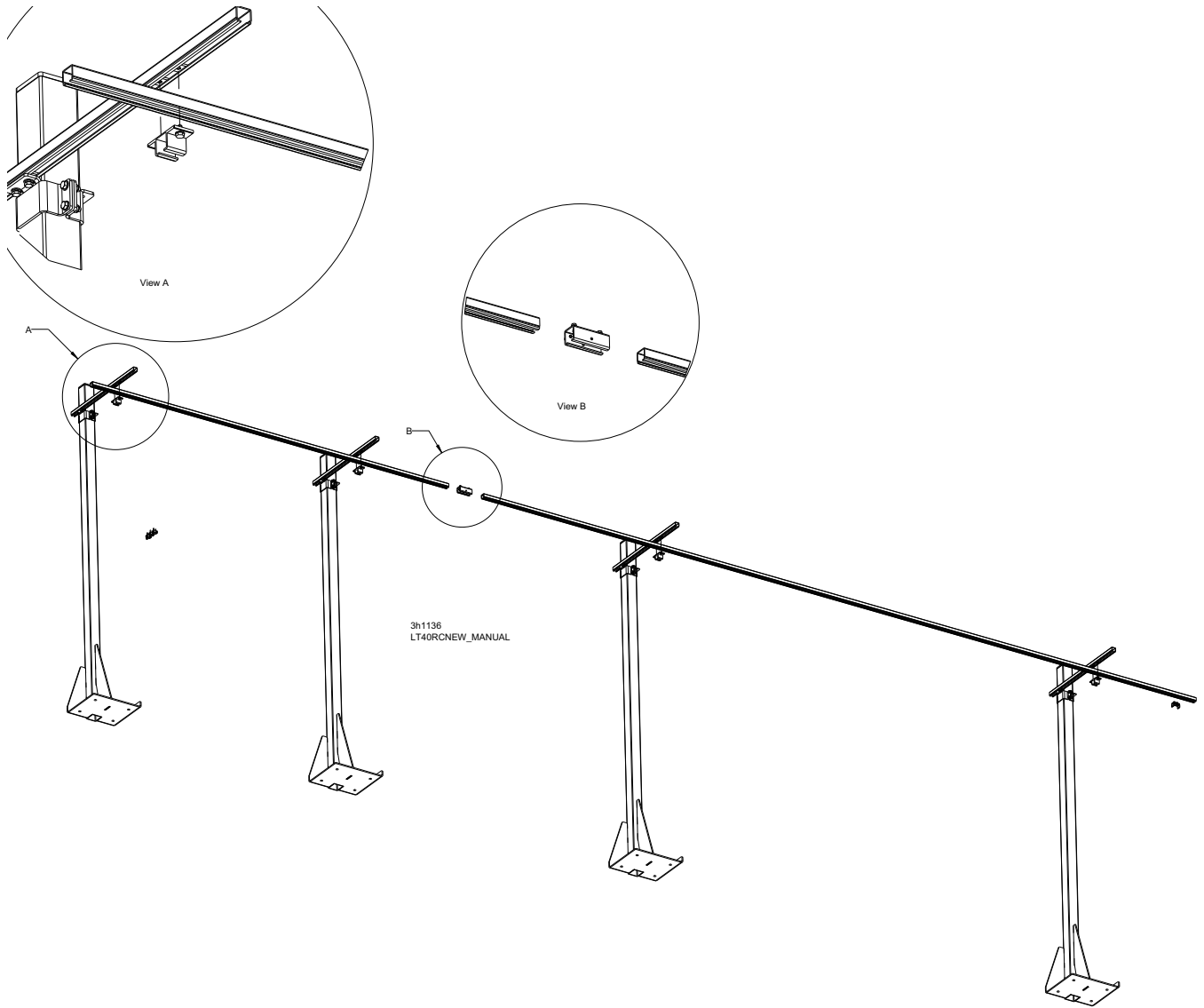

FIG. 3-9

See **Figure 3-10**. The figure below shows how the cable hanger should be set.

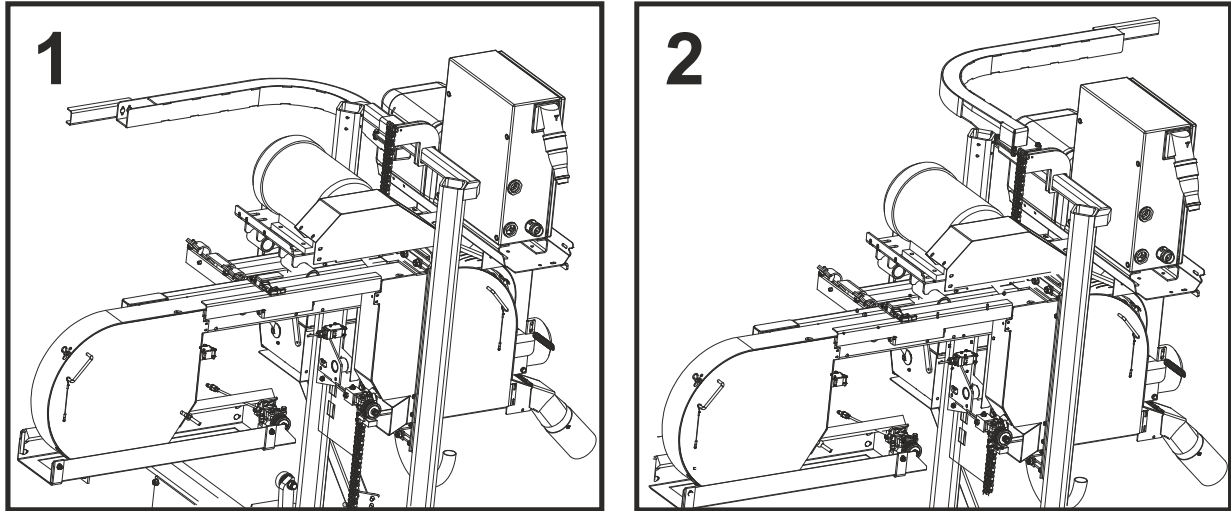

FIG. 3-10

Unbolt the four bolts, rotate the hanger 90 degrees to the right and tighten the bolts.

3.3 Middle Track Cover

Before operating the sawmill do as follows:

1. Clean the upper and lower rails to remove any sawdust and rust preventives.
2. Unbolt and remove the middle track cover from its storage position.
3. Soak the felt wiper with Dexron III transmission fluid, 10W30 motor oil or 3-in-1 turbine oil.
4. Install the middle track cover so it fits against the rail and secure with two thumb screws.

3 SETUP & OPERATION

Middle Track Cover

See Figure 3-11.

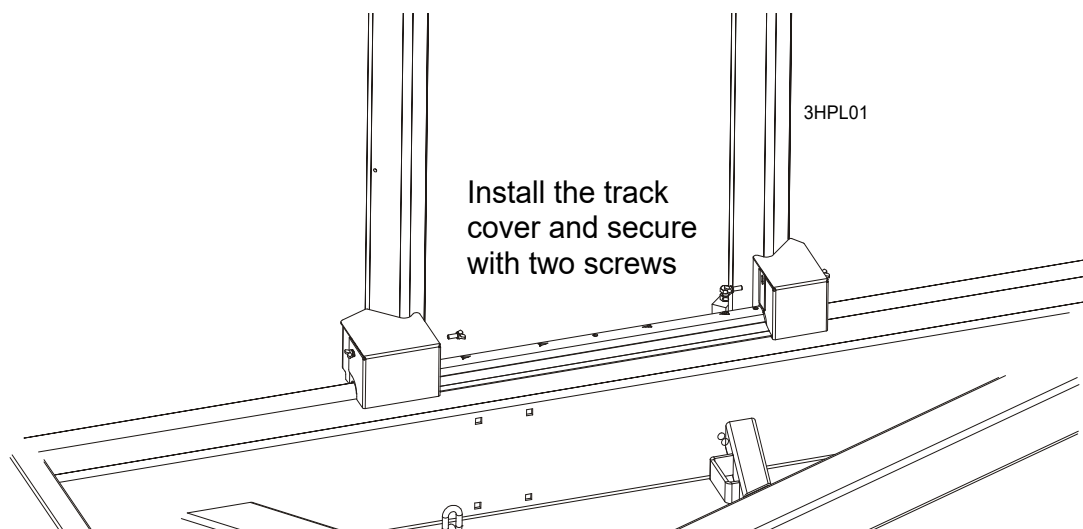

FIG. 3-11



CAUTION! Install the track cover so that it lightly touches the track rail. If the wiper presses too firmly against the rail, it can cause the power feed to bind.

3.4 Replacing The Blade



DANGER! Always disengage the blade and shut off the sawmill engine before changing the blade. Failure to do so will result in serious injury.



WARNING! Always wear gloves and eye protection when handling bandsaw blades. Changing blades is safest when done by one person! Keep all other persons away from area when coiling, carrying or changing a blade. Failure to do so may result in serious injury.

Remove the two main blade housing covers that cover the blade wheels. Lower the hinged middle blade housing cover. Turn the blade tension handle to release the blade tension until the wheel is pulled in and the blade is lying loose in the blade housing. Lift the blade out of the blade housing.

When installing a blade, make sure the teeth are pointing the correct direction. The teeth should be pointing toward the operator side of the mill when you are looking at the blade below the blade guides. Install the blade so it is lying around the wheels.

Position 1 1/4" wide blades on the wheels so the gullet is 1/8" (3.0 mm) out from the edge of the wheel. Position 1 1/2" wide blades on the wheels so the gullet is 3/16" (4.5 mm) out from the edge of the wheel.

Close the middle blade housing cover.

Next, turn the tension handle until the blade is tensioned correctly.



CAUTION! Should you need to adjust the blade position, never grab the wheel arms to spin the idle-side blade wheel as your fingers can get pinched.

3.5 Tensioning The Blade

See Figure 3-12. Tension the blade by turning the hydraulic tensioning handle clockwise until the tension gauge indicates the recommended tension.

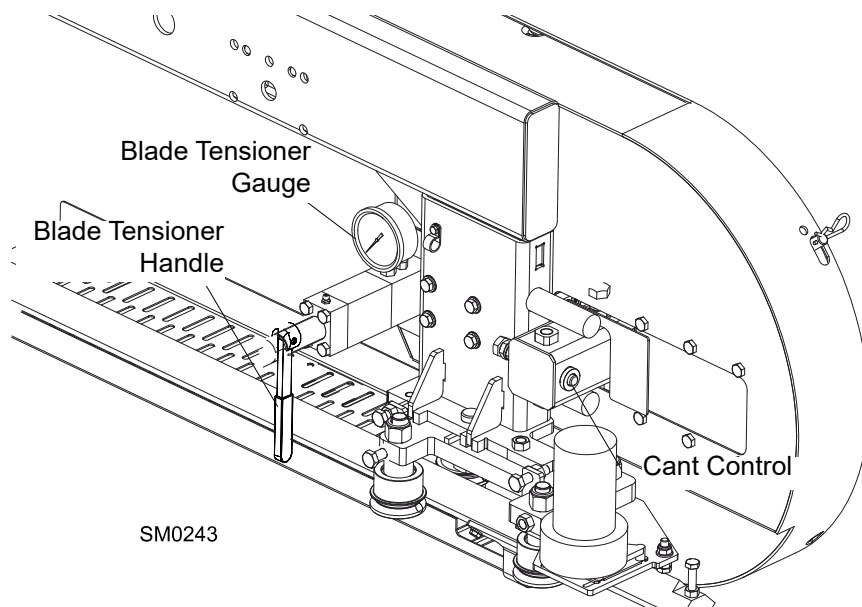

FIG. 3-12

See Table 3-11. The recommended tension for different blades is shown below.

Blade Type	Acceptable Range	Ideal Tension
B375IH929	12,4 - 14,5 MPa (1800 - 2100 psi)	13,8 MPa (2000 psi)
B275IH1030	14,5 - 16,5 MPa (2100 - 2400 psi)	15,9 MPa (2300 psi)
B2735	16,5 - 17,9 MPa (2400-2600 psi)	17,0 MPa (2466 psi)
B275IH741030	14,5 - 16,5 MPa (2100 - 2400 psi)	15,9 MPa (2300 psi)

TABLE 3-11

The tension gauge should be checked occasionally when adjusting the cant control or while cutting. Ambient temperature changes will cause tension to change. Adjust the tension handle as necessary to maintain the recommended tension level.



CAUTION! Changes in temperature could cause increased pressure in the blade tensioner and loss of fluid from the gauge. Release the blade tension when the mill is not in use to avoid damage to the tensioner.

3.6 Tracking The Blade

1. Make sure the middle blade housing cover is closed and all persons are clear of the open side of the saw head.
2. Start the motor by pushing the START button located on the control box.



WARNING! Do not spin the blade wheels by hand. Spinning the blade wheels by hand may result in serious injury.

3. Push the STOP button to stop the blade. Remove the key and check the position of the blade on the blade wheels.

See Figure 3-13. Position 1 1/4" wide blades so the gullet is 3.0 mm (0.12") out from the edge of the blade wheel (± 1.0 mm [0.04"]). Position 1 1/2" blades so the gullet is 4.5 mm (0.18") out from the edge of the blade wheel (± 1.0 mm [0.04"]).

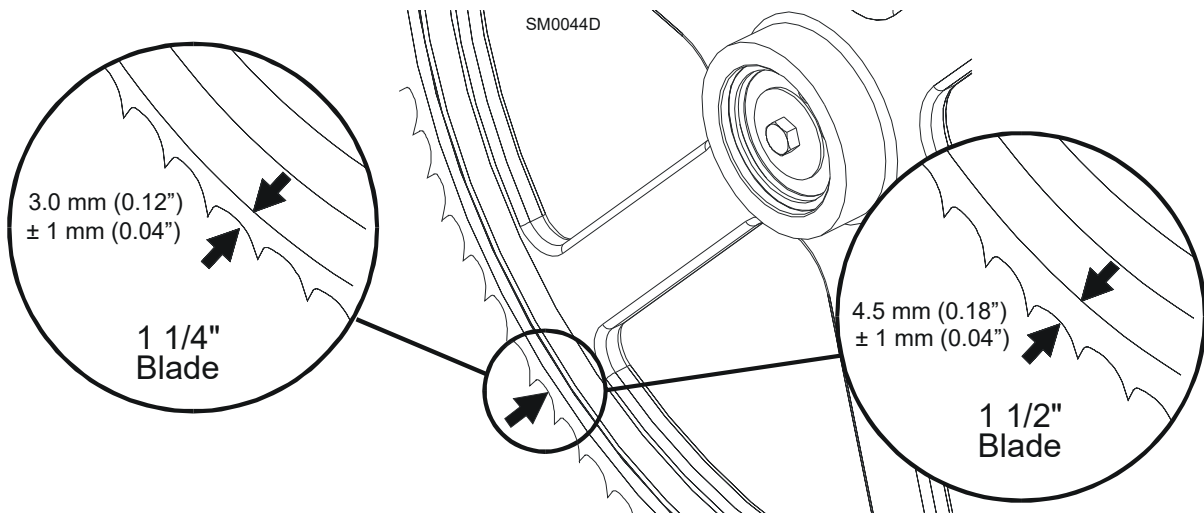

FIG. 3-13

4. To adjust where the blade travels on the blade wheels, use the cant control shown in **Figure 3-12**.

If the blade is too far out, back the blade onto the wheel by turning the cant control counterclockwise. If the blade is too far in, turn the cant control clockwise until the gullet of the blade is the correct distance from the front edge of the wheel.

5. Retension the blade to the recommended tension to compensate for any adjustments you have made in the cant control.
6. Replace the blade housing covers.



DANGER! Make sure all guards and covers are in place and secured before operating or towing the sawmill. Failure to do so may result in serious injury. Be sure the blade housing and pulley covers are in place and secure. Use the safety retainer pin and cable to fasten blade

housing covers.

IMPORTANT! After aligning the blade on the wheels, always double-check the blade guide spacing and location. (See Section 5 for more information.)

3.7 Starting The Motor (LT40 B1-4 AC)

See the appropriate manual supplied with your specific motor configuration for starting and operating instructions.



DANGER! Make sure all guards and covers are in place and secured before operating or towing the sawmill. Failure to do so may result in serious injury. Be sure the blade housing and pulley covers are in place and secure. Use the safety retainer pin and cable to fasten blade housing covers.

DANGER! Check the sawmill wiring every year. Make sure all electrical installation, service and/or maintenance work is performed by a qualified electrician.

DANGER! Do not operate or leave the sawmill with the electrical boxes open. Failure to do so may cause serious injury or death.



WARNING! Always wear eye, ear, respiration, and foot protection when operating the sawmill. Failure to do so may result in serious injury.

WARNING! Be sure the power feed switch is in the neutral position before turning the key switch to the (#1) or (#2) position. This prevents accidental carriage movement, which may cause serious injury or death.

WARNING! Hazardous voltage inside the electric box is dangerous. Turn the main switch to the OFF ("0") position and lock out power supply before opening the box door!

WARNING! Hazardous voltage inside the electric control box attached to the hydraulic control box is dangerous. Turn the main switch to the OFF ("0") position and lock out power supply before opening the box door!

WARNING! The door of the electric box can be opened only when the main switch is in the "0" position. The door is closed when the switch is in the "1" position. Serious damage to the box may result while opening the door when the main switch is in the "1" position.

At least once a year the electric wires should be checked for isolation and hazardous voltage by a qualified person.

Keep the electrical starter box clean. Remove any dust or wood chips from the box from time to time. Make sure the electric box door is closed before operating the sawmill.

WARNING! Hazardous voltage inside the electric box and inside the motor can cause shock, burns, and death. Turn the main switch to the OFF ("0") position and lock out power supply before opening the box door!

The time-delay relay in the electrical starter box attached to the hydraulic box should be set between 4 and 5 seconds.

After installation, test the sawmill for proper motor rotation.

If rotation is incorrect, turn the motor off pushing the STOP button located on the control box. Turn the main switch on the starter box to the OFF ("0") position. Disconnect the power cord on the left side of the starter box.

Use the screwdriver to turn the phase converter switch to the left or to the right to change the motor rotation.



CAUTION! If at any time you need to immediately stop the blade motor, press the emergency stop button located on the control box. **CAUTION!** If at any time you need to immediately stop the blade motor, press the emergency stop button located on the control box. **CAUTION!** If at any time you need to immediately stop the blade motor, press the emergency stop button located on the control box. **CAUTION!** If at any time you need to immediately stop the blade motor, press the emergency stop button located on the control box.

3.8 Starting The Engine (LT40 B1-4 DC)

See the appropriate manual supplied with your specific engine/motor configuration for starting and operating instructions.



DANGER! Make sure all guards and covers are in place and secured before operating or towing the sawmill. Failure to do so may result in serious injury. Be sure the blade housing and pulley covers are in place and secure. Use the safety retainer pin and cable to fasten blade housing covers.

DANGER! Always be sure the blade is disengaged and all persons are out of the path of the blade before starting the engine or motor. Failure to do so will result in serious injury.



WARNING! Always wear eye, ear, respiration, and foot protection when operating the sawmill. Failure to do so may result in serious

injury.

WARNING! Be sure the power feed switch is in the neutral position before turning the key switch to the on (#1) or accessory (#3) position. This prevents accidental carriage movement, which may cause serious injury or death.



CAUTION! If at any time you need to immediately stop the blade motor, press the emergency stop button located on the control box. **CAUTION!** If at any time you need to immediately stop the blade motor, press the emergency stop button located on the control box. **CAUTION!** If at any time you need to immediately stop the blade motor, press the emergency stop button located on the control box. **CAUTION!** If at any time you need to immediately stop the blade motor, press the emergency stop button located on the control box.

3.9 Loading, Turning, And Clamping Logs



CAUTION! Make sure the clamps and the toe boards are below bed level before loading a log onto the bed. Also, be sure the cutting head is moved far enough forward so the log does not hit it.

To Load Logs:

1. Raise the side supports.
2. Place the log at the foot of the loading ramps. Using a cant hook, roll the log onto the sawmill bed.

NOTE: Logs also may be loaded onto the mill with a forklift or other equipment specifically designed for that purpose.

To Turn Logs:

1. Disengage the clamp.
2. Use the cant hook to rotate the log on the sawmill bed.
3. Clamp the log.

To Clamp Logs:

1. Position the clamp against the log.
2. Move the clamp down far enough so that it is below your first few cuts. Using the clamp lever, clamp the log against the side supports.

See Figure 3-12.

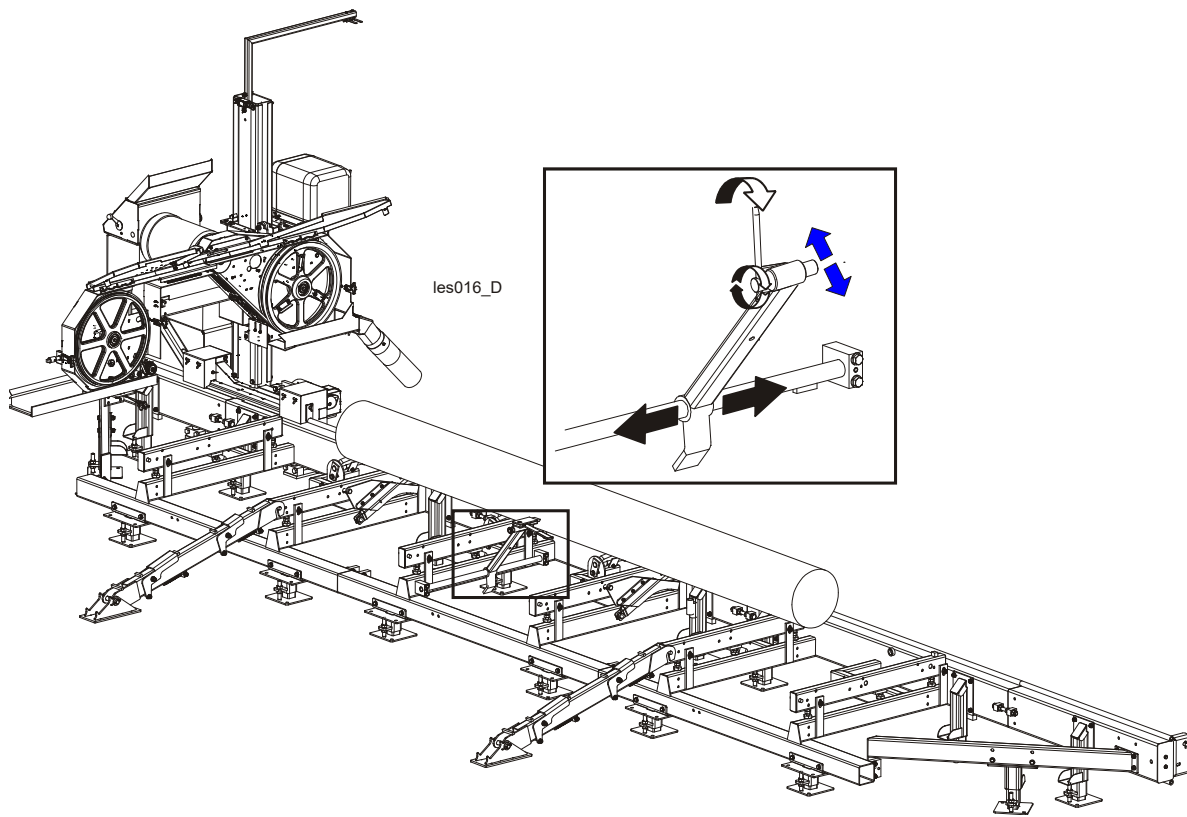

FIG. 3-12

3. Make sure the side supports are positioned low enough for the blade to pass over them. If they are not, back the clamp off slightly and push the side supports down until they are positioned below the level of your first few cuts.
4. Use the toe board levers to level the log if desired.

To Level A Tapered Log:

Use the toe board levers to raise either end of a tapered log, if desired.

3.10 Up/Down Operation

1. Install a blade, if needed, and check for correct blade tension. ([See Section 3.5](#)).
2. Set the cutting head to the desired height. (The blade height scale shows the height of the blade above the bed rails.)



See Figure 3-13. The up/down switch is located on the far right side of the control panel. Push the switch up to raise the cutting head; push the switch down to lower the cutting head. Hold the switch in position until the cutting head reaches the desired height, then release.

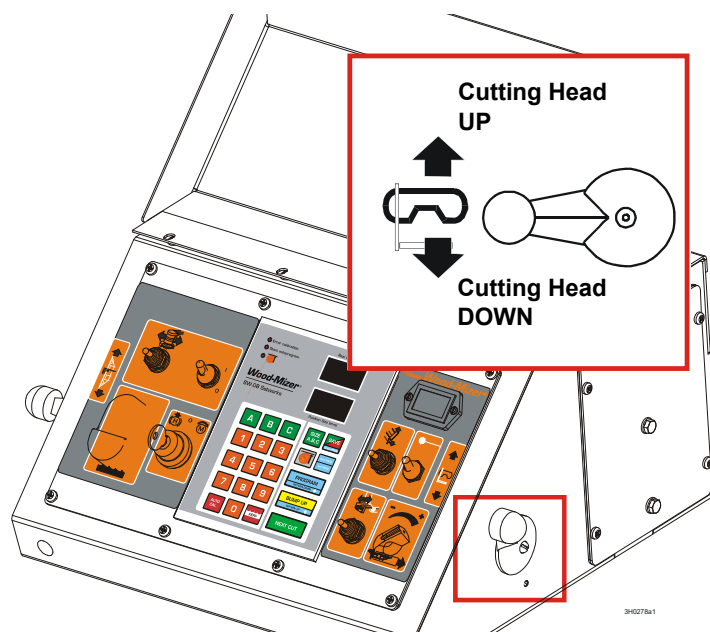

FIG. 3-13

The up/down switch is designed to return to the neutral or "off" position when released. If the switch remains engaged, manually move the switch to the neutral or "off" position. Repair the up/down drum switch ().



CAUTION! Always make sure the up/down switch moves to the neutral or "off" position when released to ensure that the saw head stops moving. Failure to do so may result in machine damage.

CAUTION! DO NOT try to force the carriage above the 35" (88 cm) mark or below the 1" (2.54 cm) mark. Damage to the up/down system may result.

3.11 Blade Guide Arm Operation

1. Look down the length of the log to see its maximum width. The outer blade guide should be adjusted to clear the widest section of the log by less than 1" (25.4 mm).
2. Use the blade guide toggle switch on the control panel to adjust the outer blade guide as necessary. Push the switch to the left to move the arm in. Push the switch to the right to move the arm out.

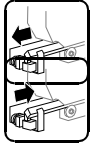

See Figure 3-14.

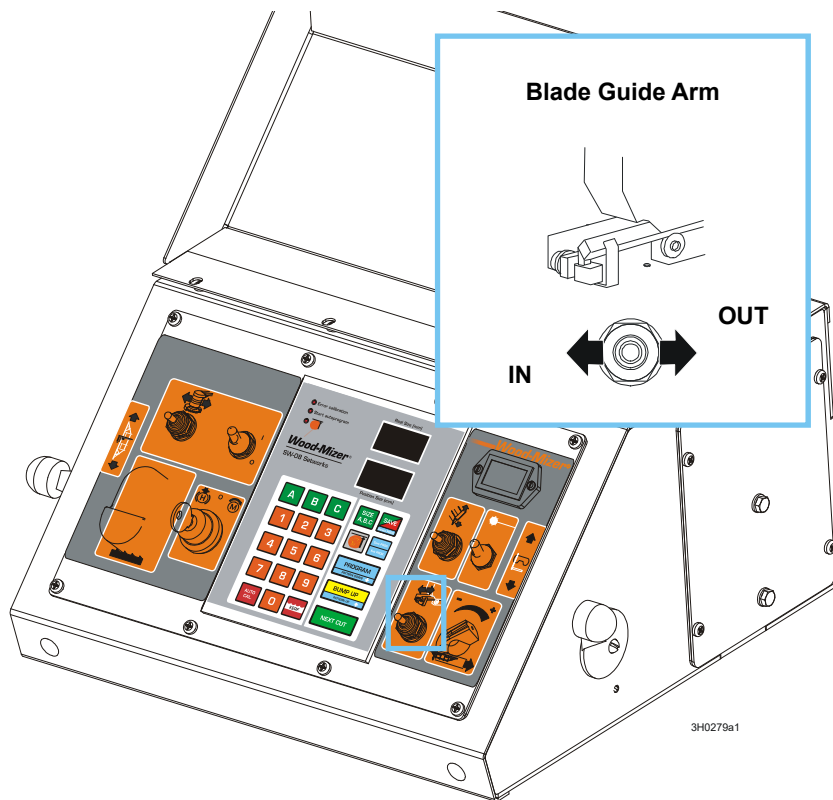



FIG. 3-14

3. Use the blade guide toggle switch to readjust the outer blade guide as you are cutting in order to keep the guide within 1" (2.5 cm) of the log. Be sure to adjust the arm back out before returning the carriage.

3.12 Clutch/Brake Operation

NOTE: If your sawmill is equipped with the Remote Option, see the option manual for clutch/brake operation.

1. Clear any loose objects from the area of the blade, motor, and drive belt.
2. Make sure the clamp and side supports are adjusted below the level of your first few cuts.
3. Start the engine or motor as instructed in the engine manual.

 **DANGER!** Make sure all guards and covers are in place and secured before operating or towing the sawmill. Failure to do so may result in serious injury. Be sure the blade housing and pulley covers are in place and secure. Use the safety retainer pin and cable to fasten blade housing covers.

Be sure the blade housing and pulley covers are in place and secure before starting the engine or motor. Use the safety retainer pin and cable to fasten blade housing covers.

See **Figure 3-15**. The clutch/brake lever is located next to the engine.

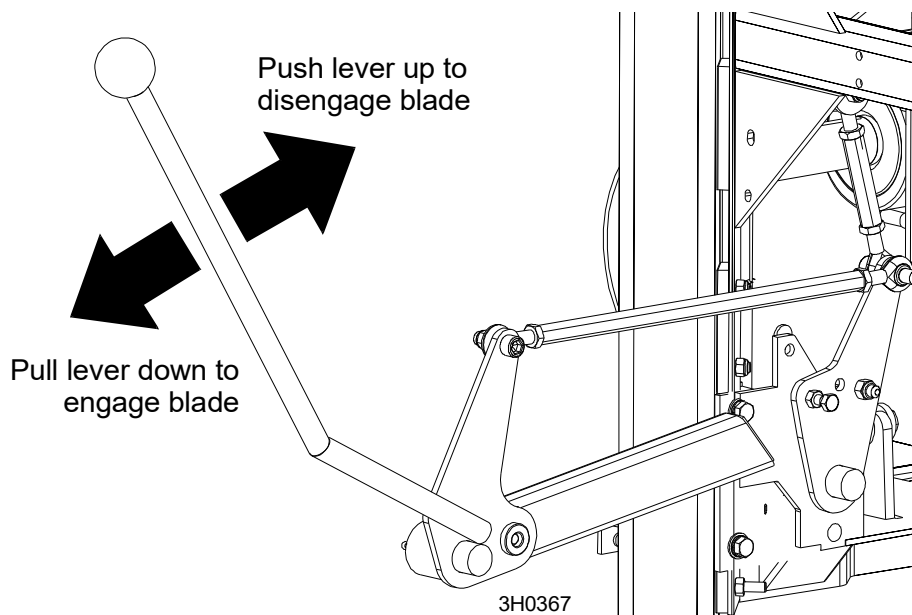

FIG. 3-15

4. To engage the blade, pull the lever down until it locks in the down position. This engages the drive mechanism, releases the blade brake, and increases the engine speed to full throttle.

To disengage the blade, raise the clutch/brake lever to the up position. This disengages the drive belt, engages the blade brake, and returns the engine to idle.

3.13 Power Feed Operation

See Figure 3-16. The power feed system moves the carriage forward and backward by using two switches on the control panel.

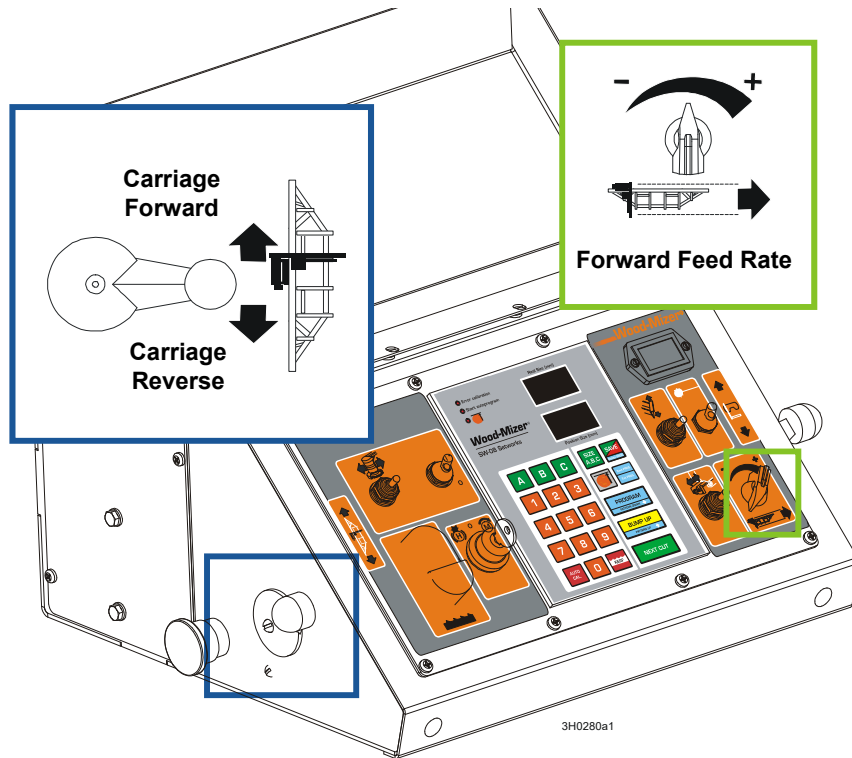



FIG. 3-16

Carriage Feed Rate

 The carriage feed rate switch controls the speed at which the carriage travels forward. Turn the switch clockwise to increase speed. Turn it counterclockwise to reduce speed.

Carriage Forward and Reverse

 The carriage forward/reverse switch controls the direction in which the carriage travels. Turn the forward/reverse switch upward to move the carriage forward. Turn the switch down to move the carriage backward.

The middle position (as shown) is the neutral position. The power feed switch is designed to return to the neutral or "off" position when released from operating in the reverse position. If the switch remains engaged, manually move the switch to the neutral or "off" position. Repair the drum switch ([See Section 4.2](#)).

 **WARNING!** Be sure the power feed switch is in the neutral position before turning the key switch to the (#2) or (#1) position. This prevents accidental carriage movement, which may cause serious injury or death.

Using The Power Feed



HINT: To get a straight cut in the first part of the board, feed the blade into the log at a slow speed. This stops the blade from flexing and dipping up or down. Turn the carriage feed rate switch to a slow speed until the whole width of the blade has entered the cut. Then use the carriage feed rate switch to increase the feed rate as desired. Maximum feed rate varies with width and hardness of the wood. Over-feeding results in engine and blade wear, and also produces a wavy cut.



Stop the carriage at the end of the cut by turning the carriage feed rate switch counterclockwise until the carriage stops moving.

2. Push the STOP button to stop the blade. Remove the board from the top of the log.



CAUTION! Be sure to stop the blade when returning the carriage. This will not only prevent the blade from being pulled off and ruined by a wood sliver, but also will increase the life of the blade. [See Section 3.15](#) for optional procedure for Super series mills.



3. Return the carriage to the front of the mill by turning the carriage forward/reverse switch down. The power feed motor will bypass the carriage feed rate switch and the carriage will automatically return at the fastest speed available. **Always disengage the blade before returning the carriage for the next cut.** [See Section 3.15](#) for optional procedure for Super series mills.

4. Make sure that the blade does not catch on the end of the log. Raise the carriage slightly to make sure the blade clears the log when returned. **HINT:** Try to stop the blade while the heel of the blade is still on the log. Then bring the carriage back without adjusting the blade up. This lets you keep the blade at the current height setting so you can make the next blade height adjustment more quickly.



DANGER! Stay clear of the area between the trailer axle and saw carriage. Failure to do so will result in serious injury.

3.14 Blade Height Scale

See Figure 3-17. The blade height scale is attached to the carriage head frame. It includes:

- a blade height indicator
- an metric or inch scale

- a quarter scale

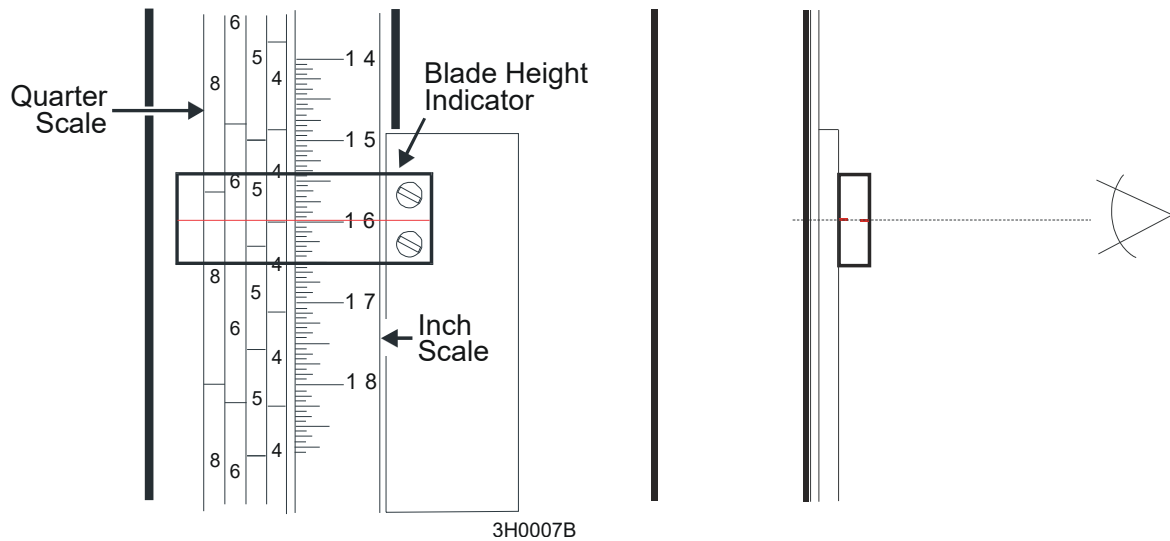

FIG. 3-17

The scales are attached to the frame and move up and down with the carriage head. The blade indicator, used to read the inch and quarter scales, remains stationary.

Blade Height Indicator

The blade height indicator has two horizontal, red lines on both sides. Readings should be taken with eyes level with the indicator, when the two red lines are in line. This will allow to avoid the parallax error (different scale readings depending on the angle of vision).

The Inch Scale

The horizontal red line on the blade height indicator shows how many inches the bottom of the blade is above the bed of the mill. If you know the height of your blade at each cut, you can determine the thickness of lumber you are sawing.

Example: You want to cut 1" (25 mm) random width boards from a log. Position the blade for the first cut. Move the carriage to an even measurement on the inch scale. Make a trim cut. Return the carriage for the second cut and lower it 1 1/8" (29 mm) below the original measurement. (The extra 1/8" (3 mm) allows for saw kerf and shrinkage of the lumber.)

The yellow area on the scale identifies where the blade could encounter a side support or log clamp. Check that these items are below the blade level before sawing.

The Quarter Scale

See Table 3-3. Two quarter scales are provided with four sets of marks. Each set represents a specific lumber thickness. Saw kerf and shrinkage allowance are included, but actual board thickness will vary slightly depending on blade thickness and tooth set.

To choose which scale to use, determine what finished thickness you want to end up with. The Grade Hardwood Quarter Scale provides thicker finished boards usually required by commercial buyers. The Standard Quarter Scale allows for kerf and shrinkage of finished boards suitable for most custom applications. Always check with your customer before you saw to determine what actual finished thickness is required.

Standard Quarter Scale		Grade Hardwood Quarter Scale	
Scale	Actual Board Thickness	Scale	Actual Board Thickness
4/4	1" (25 mm)	4/4	1 1/8" (29 mm)
5/4	1 1/4" (32 mm)	5/4	1 3/8" (35 mm)
6/4	1 1/2" (38 mm)	6/4	1 5/8" (41 mm)
8/4	2" (51 mm)	8/4	2 1/8" (54 mm)

TABLE 3-3

To use the quarter scale, look at the blade height indicator. Line up the horizontal red line on the indicator with the nearest mark on the scale you want to use. Make a trim cut. When you return the carriage for a second cut, lower the carriage to the next mark on the scale. This mark shows where the blade should be positioned to cut a certain thickness of lumber, without having to measure on the inch scale.

Example: You want to cut 1" (25 mm) (4/4) random width boards from a log. Position the blade for the first cut. Adjust the quarter scale so a 4/4 mark is aligned with the red line on the indicator. Make a trim cut. Return the carriage for the second cut. Now, instead of having to measure down 1 1/8" (29 mm) on the inch scale, you can simply lower the blade so the indicator is aligned with the next 4/4 mark on the quarter scale. Turn the log 90 degrees and repeat.

3.15 Water Lube Operation

See Figure 3-18. The Water Lube System keeps the blade clean. Water flows from a 5-gallon (18.9 liter) bottle through a hose to the blade guide where the blade enters the log. A valve in the bottle cap controls the amount of water flow.

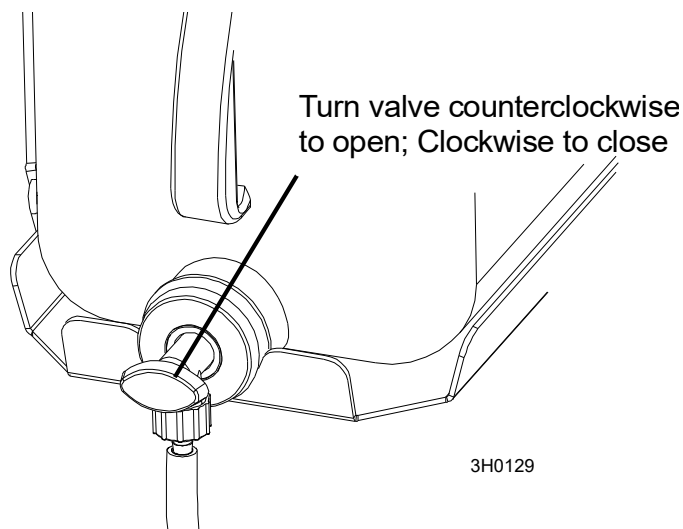



FIG. 3-18

Super models include a solenoid valve that will automatically start the water flow when the power feed is activated in the forward direction. The solenoid will stop the water flow when the feed switch is returned to the neutral position.

Not all types of wood require the use of the Water Lube System. When it is needed, use just enough water to keep the blade clean. This saves water, and lowers the risk of staining the boards with water. Usual flow will be 1-2 gallons (3.8-7.6 liters) per hour. A squirt of liquid dishwashing detergent in the water bottle will help clean the blade when cutting wood with a high sap content.

 **WARNING!** Use ONLY water with the water lube accessory. Never use flammable fuels or liquids. If these types of liquids are necessary to clean the blade, remove it and clean with a rag. Failure to do so may result in serious injury or death.

Before removing the blade, start the motor. Let the blade spin with water running on it for about 15 seconds. This will clean the blade of sap buildup. Wipe the blade dry with a rag before storing or sharpening.

If you are sawing in freezing temperatures, remove the water lube bottle from the sawmill when done sawing and store it in a warm place. Blow any remaining water from the water lube hose.

To remove water from the water valve on Super models, turn the key switch to accessory (#1), turn the feed rate knob down to '0' and place the feed switch in the forward position. Blow any remaining water from the water lube hose and valve. Return the forward/reverse switch to neutral and turn the key switch to off (#0).

SECTION 4 MAINTENANCE

This section lists the maintenance procedures that need to be performed.

The Short Interval Maintenance Schedule lists procedures that need to be performed every 4, 8 or 25 hours. The Maintenance Log lists procedures that need to be performed every 50, 100, 200, or 1000 hours. Keep track of machine maintenance by filling in the machine hours and the date you perform each procedure.



This symbol identifies the interval (hours of operation) at which each maintenance procedure should be performed.

Be sure to refer to option and engine manuals for other maintenance procedures.

4.1 Wear Life

See Table 4-1. This chart lists estimated life expectancy of common replacement parts if proper maintenance and operation procedures are followed. Due to the many variables which exist during sawmill operation, actual part life may vary significantly. This information is provided so that you may plan ahead in ordering replacement parts.

Part Description	Estimated Life
B57 Blade Wheel Belts	500 hours
Up/Down Motor	2000 hours
Up/Down Drum Switch	1000 hours
Blade Guide Rollers	1000 hours
Power Feed Drum Switch	1200 hours
Drive Belt	1250 hours
Power Feed Motor	1500 hours
Power Feed Belt	2000 hours
Up/Down Belt	2000 hours

TABLE 4-1

4.2 Blade Guides

1. Check the rollers for performance and wear every blade change. Make sure the rollers are clean and spinning freely. If not, rebuild them. Replace any rollers which have worn smooth or have become cone shaped. See The LT40LT40 Series AH Parts manual for blade guide rebuild kits and complete roller assemblies.

Steel Blade Guide Blocks

2. Inspect the blocks at every blade change for damage or wear. If the block housing is bent or damaged, replace the block assembly.

As the blocks wear, the front inside corner will wear more than the body of the block. When the corner wears far enough, sawing performance will be affected even if the body of the block is adjusted properly to the blade. At this point, the block should be replaced. If you have access to the appropriate equipment, you can grind or mill the blocks to a new flat surface and reuse them. It is recommended you develop a routine schedule for replacing the blade guide blocks based on your sawing conditions and experience.

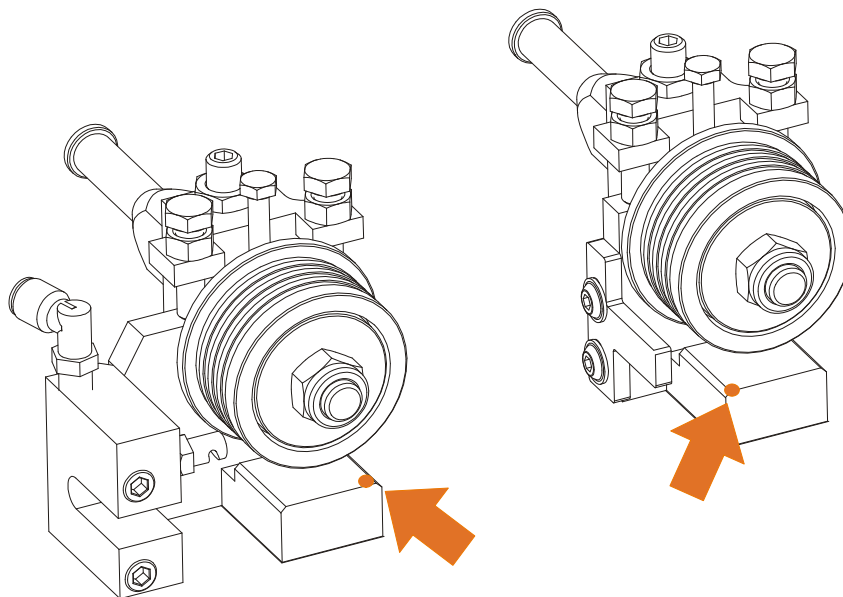

RYS. 4-0

3. Check the inserts are properly spaced from the bottom of the blade every 25 hours of operation. As the rollers wear, the gap between the blade and inserts will become larger. Use the provided shim or a feeler gauge to check the inserts are adjusted 0,3 - 0,5 mm from the blade.

25

See Figure 4-1. To adjust the disks up, loosen the bottom guide disk mounting bolt and clamp bolt. Use the provided adjustment tool. to raise bottom disk Retighten the bottom disk mounting bolt and clamp bolt. See Section:



IMPORTANT! The inserts should be parallel to the blade. Check the space between the insert and the blade at each side of the insert to insure it is parallel. Use the appropriate outer adjustment bolt to tilt the

insert mounting plate so the insert is parallel to the blade.

After adjusting the drive side blade guide block insert up, check the deflector. If necessary, loosen the two deflector mounting screws and adjust the deflector so it does not touch the blade.

See Figure 4-2.

4. Make sure the blade screw in the top center of the C-frame is 1/16" (1.5 mm) below the bottom of the blade. If not, loosen the nut and adjust the screw as necessary. Check the screw every blade change. Failing to maintain this adjustment will lead to early blade breakage.

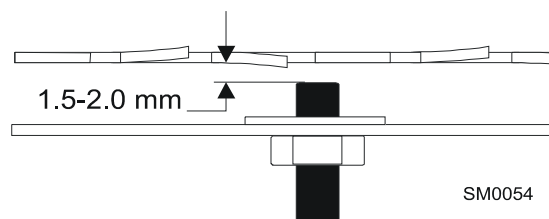

FIG. 4-2

4.3 Sawdust Removal

1. Remove the excess sawdust from the blade wheel housings and sawdust chute every blade change.
2. Remove all sawdust and debris from around the velocity fuse valves every 8 hours of operation. The valves are located at the bottom of the log loader cylinders.
3. Remove sawdust buildup as necessary from top rail cover.



CAUTION! Failure to remove sawdust buildup from track rail cover could result in damage to these parts when the saw head is lowered to its lowest position.

4. As required, remove sawdust buildup from the power feed belt housing. Turn the control panel key switch to OFF (0) and remove the key. Disassemble the power feed belt cover and remove sawdust buildup in and around the power feed belt and pulleys. Replace the power feed belt cover.

4.4 Carriage Track, Wiper & Scrapers

See Figure 4-3.

- 8 **1.** Clean the upper and lower track rails to remove any sawdust and sap buildup every eight hours of operation. Lubricate the lower track rail by wiping it with Dexron III ATF.
- 8 **2.** Remove sawdust from the upper cam housings. Loosen the thumb screws on the upper cam housing covers and open. Brush any sawdust buildup from the housings.
- 3.** Check the track scrapers as needed. Make sure the scrapers fit firmly against the rail. If a track scraper needs to be adjusted, loosen the thumb screw, push the scraper downward until it fits firmly against the rail, and retighten the thumb screw.

Clean and lubricate the upper track wiper every twenty-five hours of operation. Unbolt the wiper, remove it from the sawmill, and remove any sawdust buildup. Soak the felt wiper with Dexron III transmission fluid, 10W30 motor oil or 3-in-1 turbine oil.



CAUTION! Reinstall the track wiper so that it lightly touches the track rail. If the wiper presses too firmly against the rail, it can cause the power feed to bind.

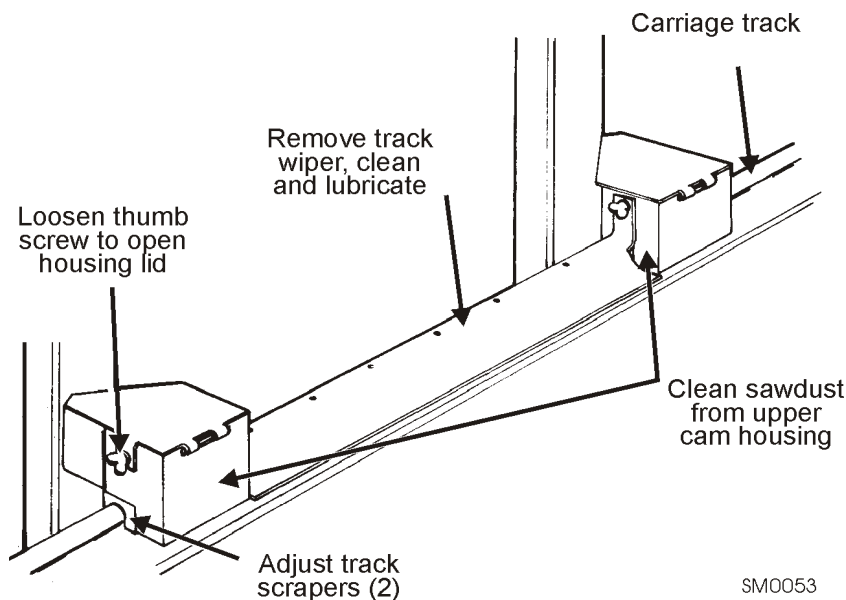

FIG. 4-3

4.5 Vertical Mast Rails



Clean and lubricate the vertical mast rails every 50 hours of operation. Clean with solvent and remove any rust with a light-grade sand paper or emery cloth. Lubricate the mast with motor oil or automatic transmission fluid (ATF).



CAUTION! Never use grease on the mast rails as it will collect sawdust.

4.6 Drum Switches



Lubricate the up/down and power feed drum switch contacts inside the control panel every fifty hours of operation. Use only contact grease supplied by Wood-Mizer. Remove the control panel cover. Use a cotton swab to apply grease to the switch contact ends.



WARNING! Drum switch grease contains Petroleum Hydrocarbon Lubricant. Eye and skin irritant. If introduced into eyes, flush with water for at least 15 minutes. If film or irritation persists, seek medical attention. Wash skin with soap and water. If ingested, do not induce vomiting - contact a physician. **KEEP OUT OF THE REACH OF CHILDREN.**

4.7 Miscellaneous

1. Apply a thin film of a NLGI No. 2 grade lithium grease to the blade guide arm every fifty hours of operation to help prevent it from rusting.
50
2. Lubricate the log turner (if equipped) with a NLGI No. 2 grade lithium grease every fifty hours of operation. Lubricate the turner pivot pins with WD-40 or a dry lube.
50
3. Grease the clamp mechanism, loading arm, and side supports with a NLGI No. 2 grade lithium grease every fifty hours of operation.
50
4. Oil all chains with Dexron III ATF every fifty hours of operation.
50



CAUTION! Do not use chain lube. It causes sawdust buildup in chain links.

5. Lubricate the board return pivot every fifty hours of operation with a NLGI No. 2 grade lithium grease. Apply grease to the grease fitting on the board return pivot tube.
50
6. Check the mill alignment every setup. See Section 5, Alignment.
7. Make sure all safety warning decals are readable. Remove sawdust and dirt. Replace any damaged or unreadable decals immediately. Order decals from your Customer Service Representative.
8. Lubricate the clutch lever bushings every 200 hours of operation (or once a month). Apply lithium grease to the fitting.

4.8 Blade Tensioner

1. Lubricate the chrome rods of the tensioner system with a heavy duty teflon spray lubricant, such as Gunk L508, every 50 hours of operation.

50

2. Lubricate the tensioner screw handle with a NLGI No. 2 grade lithium grease as needed.

See Figure 4-4.

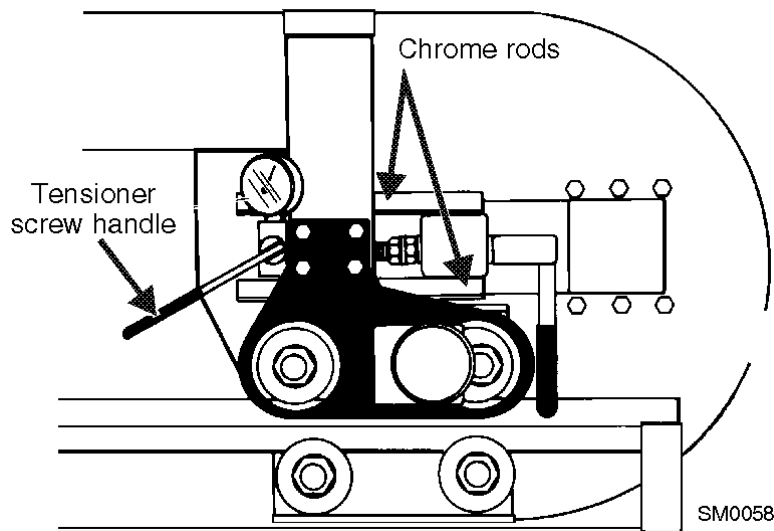

FIG. 4-4

3. Add an Automatic Transmission Fluid (ATF) such as Dexron III ATF to the hydraulic blade tensioner as needed.

See **Figure 4-5**. To add enough fluid to completely fill the tensioner block:

- Remove the tensioner handle and ball. Remove the sawmill blade housing covers, blade and idle-side blade wheel.
- Push the idle-side shaft housing all the way in to collapse the rear tensioner piston and fully extend the front piston. The front piston should reach the threaded area of the piston guide.

NOTE: If the hydraulic fluid level is extremely low, collapsing the rear piston may not fully extend the front piston. If it does not, finish the fill procedure in its entirety and repeat. The first pass should add enough fluid to allow the front piston to fully extend. The second pass should add enough fluid to completely fill the block.

- Locate the fill plug behind the tension gauge. Clean any dirt and debris from the plug area. Use a 7/16" wrench to remove the plug, making sure to keep the plug o-ring with the plug.
- Manually extend the rear piston (the front piston should remain extended).
- Use a small funnel or cup to completely fill the block with hydraulic fluid. When full, place the fill plug in the fill plug hole and thread 1-2 turns. Manually push the rear piston all the way in to allow excess oil and air to bleed from system through the plug. Tighten the plug all the way.
- Reinstall the idle-side blade wheel, blade and blade housing covers. Reinstall the tensioner ball and handle.

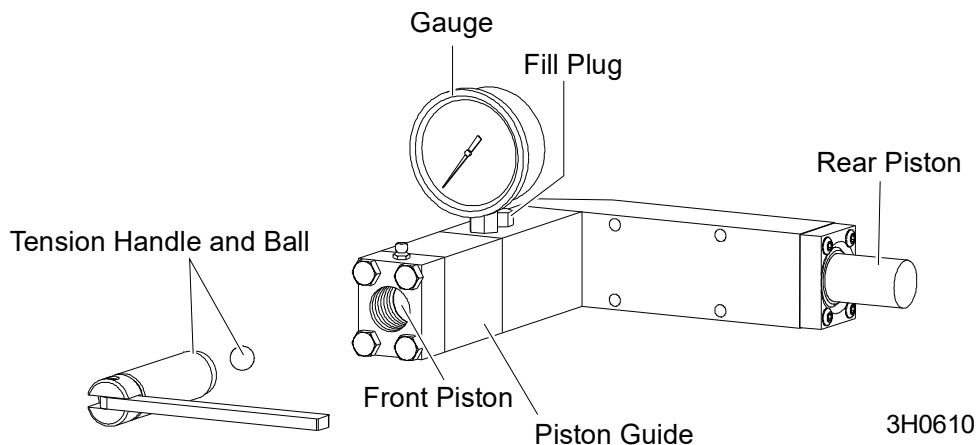

FIG. 4-5

4.9 Brake Strap Adjustment

200

Check the brake strap for wear every 200 hours of operation. Replace if damaged or worn.

Also check and adjust the brake strap if the blade does not stop quickly, unusual sounds occur when the brake is applied, or a sudden change is noticed in the clutch handle position when the clutch is disengaged.

To access the brake strap, remove the belt cover located underneath the engine. Engage the clutch/brake lever.

See Figure 4-6. Loosen the two nuts on the upper brake strap bracket. Slide the bracket and brake strap down until snug. Retighten the bolts. Replace the belt cover.

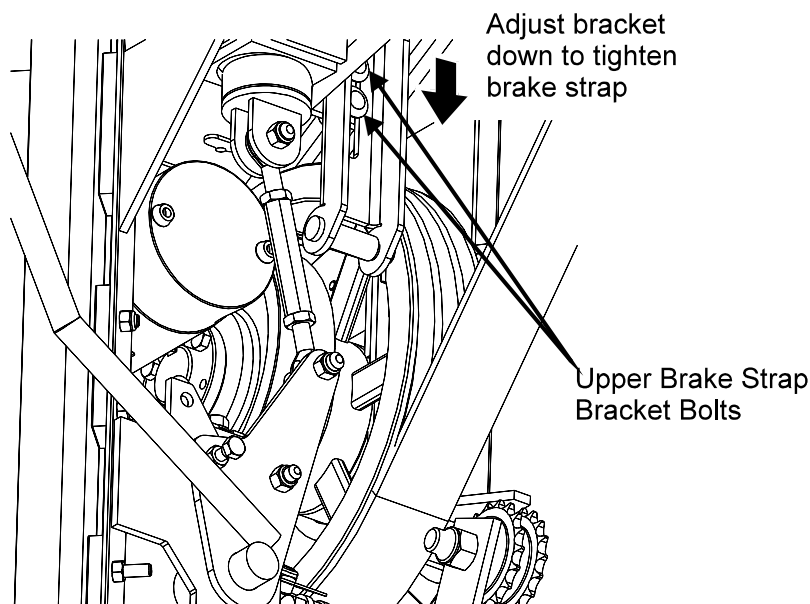

FIG. 4-6

4.10 Blade Wheel Belts

50

1. Rotate the blade wheel belts and check them for wear. Rotating the belts every 50 hours will give you longer belt life. Replace belts as necessary. Use only B57 belts manufactured by Goodyear or Browning.
2. Periodically check all belts for wear. Replace any damaged or worn belts as needed.

4.11 Drive Belt Adjustment



WARNING! Do not for any reason adjust the engine drive belts or belt support bracket with the engine running. Doing so may result in serious injury.

50

See **Table 4-2**. Check the drive belt tension after the first 20 hours, and every 50 hours thereafter. See the table below for drive belt tension specifications for your model sawmill.

Engine/Motor	Belt Tension
E20	7/16" (11mm) deflection with 16 lbs. of deflection force
E25	7/16" (11mm) deflection with 16 lbs. of deflection force
D42	7/16" (11mm) deflection with 16 lbs.(7,2kg) of deflection force

TABLE 4-2

1. Remove the two belt covers located underneath the engine.
2. **For Manual Clutch Handle:** Loosen the drive belt turnbuckle jam nuts. Turn the turnbuckle counterclockwise (as viewed from the top) to tighten the belt, clockwise to loosen the belt.

See **Figure 4-7**.

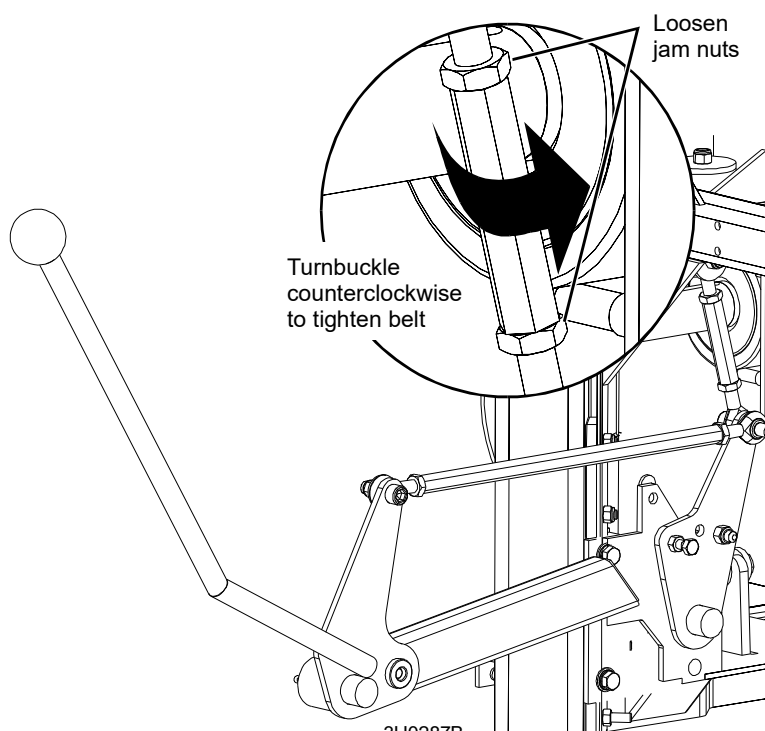

FIG. 4-7

3. **For Autoclutch Option:** Place a wrench on the flats at the top of the turnbuckle. Use a second wrench to turn the bottom-most jam nut clockwise (as viewed from the bottom) to tighten the belt, counterclockwise to loosen the belt.

See Figure 4-8.

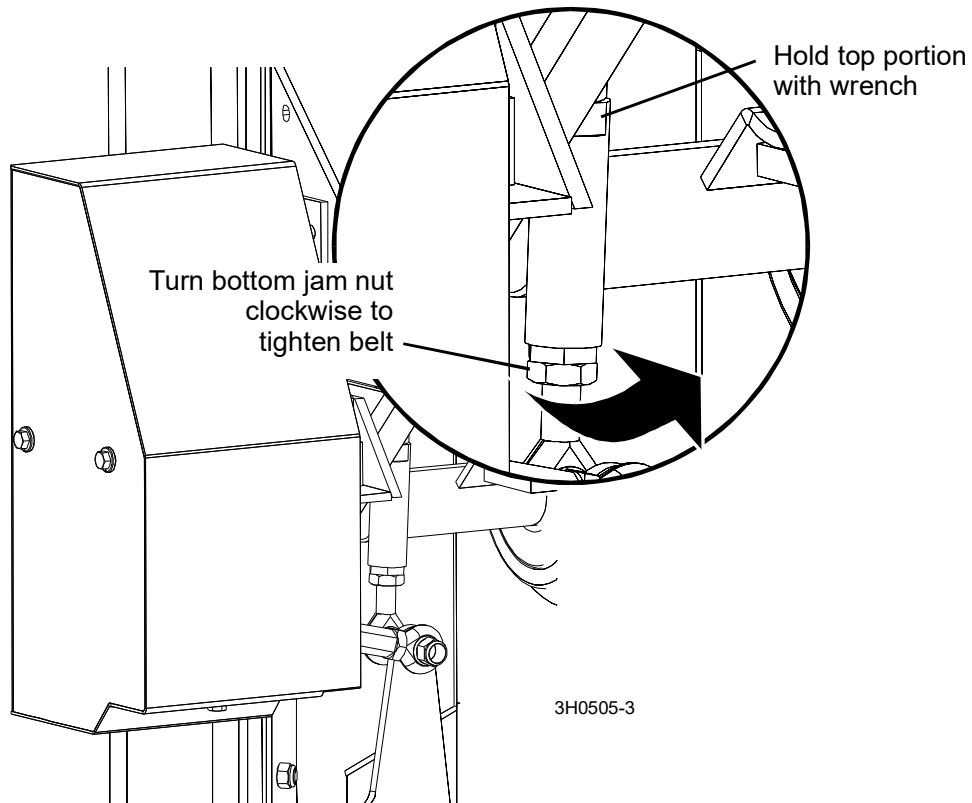

FIG. 4-8

- 4. Gas/Diesel Engines Only:** After tensioning the drive belt, check throttle cable tension and adjust if necessary. The throttle cable should be tensioned just enough so that the engine revs as soon as the clutch/brake handle is engaged. The throttle linkage should NOT affect engine RPM while the clutch/brake handle is disengaged. **NOTE:** A properly adjusted throttle will extend the cable spring 1/4" to 3/8" (6.4 - 9.5 mm) when running and have a slight amount of slack in the cable when idling. Always be sure to check the drive belt support after adjusting drive belt tension.



Periodically check all belts for wear. Replace any damaged or worn belts as needed.

AR

Adjust the drive belt support as needed. The drive belt support is designed to extend belt life. The bracket should be adjusted to NOT touch the drive belt when the clutch handle is engaged (down position), AND to hold the drive belt away from the engine pulley when the clutch handle is disengaged (up position).

See Figure 4-9. To adjust the drive belt support:

1. Make sure the motor is not running. Loosen the adjustment bolts.
2. Position the bracket so that the prong is close to, but does not touch, the drive belt with the clutch handle engaged (down position).
3. Retighten the adjustment bolts 25-27 pound feet (34-37 newton meters).

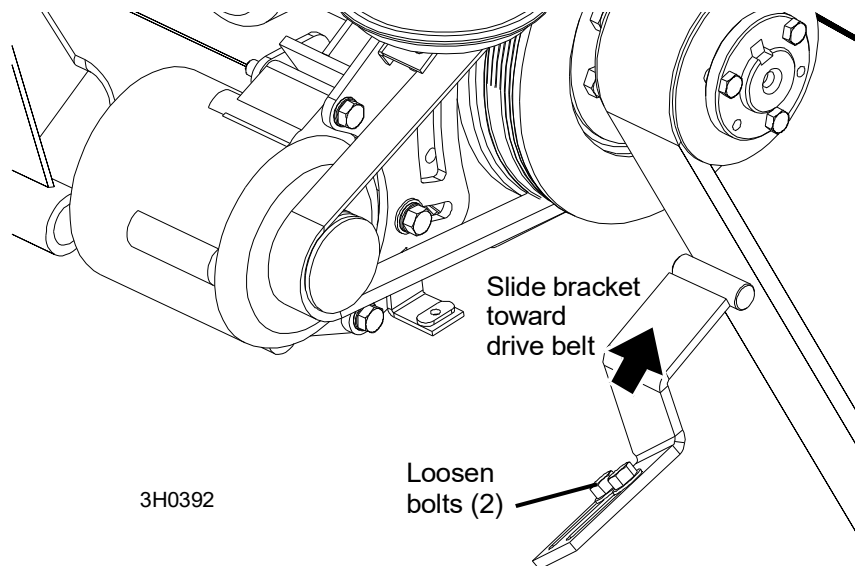

FIG. 4-9

4.12 Clutch Handle Adjustment

After the drive belts and brake strap are properly adjusted, the clutch handle should lock in the down position when the drive belts are engaged. If the clutch handle does not stay locked, adjust the handle turnbuckle. [See Section 4.13](#) for optional Autoclutch adjustment.

1. Remove the blade from the sawmill.
2. Remove the inner belt guard and pull the clutch handle down to engage the drive belts.
3. Hold a straight edge between the bottom and top pivot centers and measure the distance to the middle pivot.
4. Adjust the clutch handle turnbuckle until the center of the middle pivot is $7/16$ " from the straight edge.

See Figure 4-10.

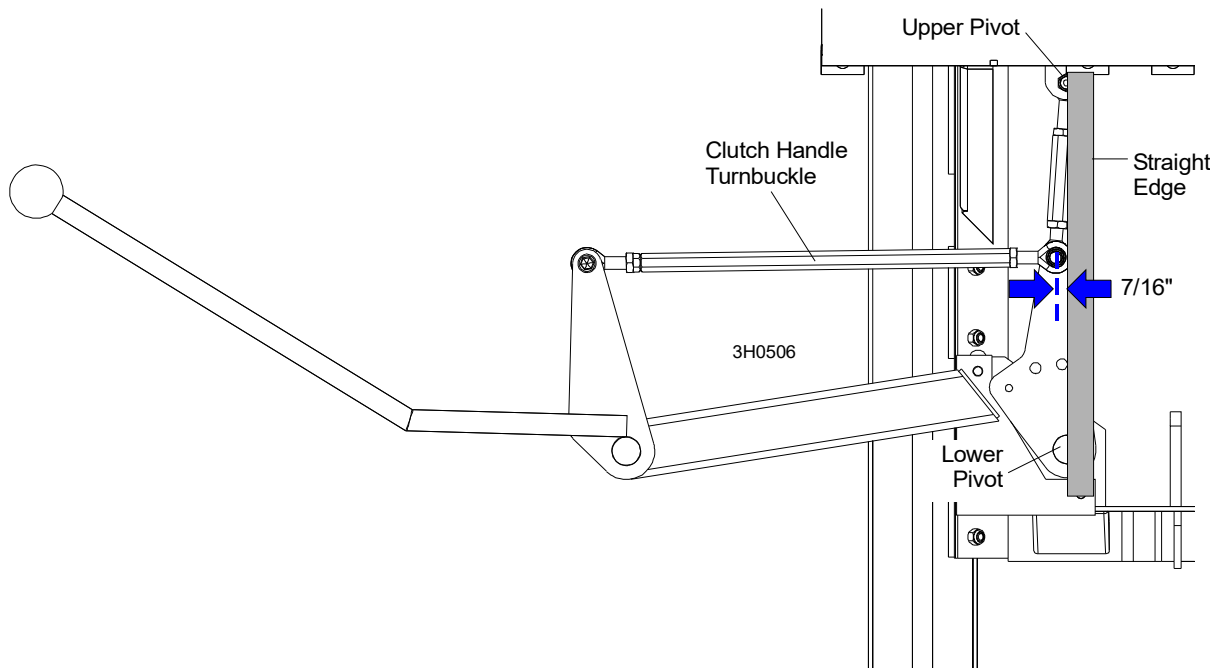

FIG. 4-10

4.13 Autoclutch Option Adjustment

If your sawmill is equipped with the Autoclutch option, check the clutch linkage after every drive belt or brake strap adjustment.

1. Remove the blade from the sawmill.
2. Remove the inside belt guard and push the Autoclutch switch up to engage the drive belts.
3. With the belts engaged, place a straight edge between the upper and lower clutch pivot centers. Measure the distance to the middle pivot.
4. Adjust the Autoclutch turnbuckle so the middle pivot is positioned $7/16$ " behind the straight edge.

See Figure 4-11.

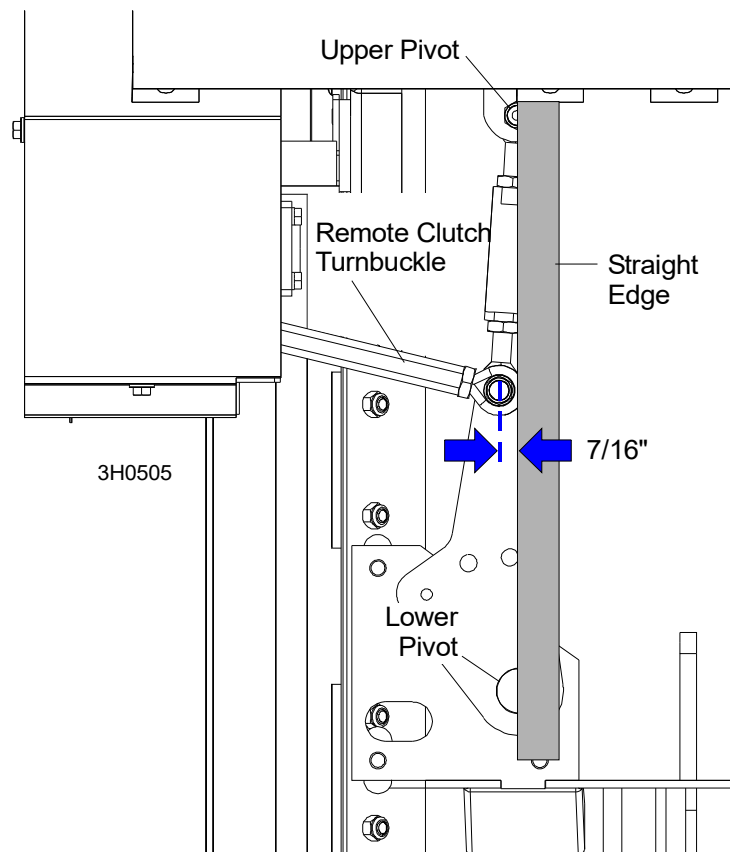

FIG. 4-11

4.14 Drive Bearing

500

Refill the fluid in the drive-side cylinder bearing housing every 500 hours of operation. Remove the top and bottom oil plugs. Pour an Automatic Transmission Fluid (ATF) such as Dexron III ATF into the top hole until it begins to flow from the bottom hole. Reinstall the square oil plug to the bottom hole and the vented oil plug to the top hole.

See Figure 4-12.

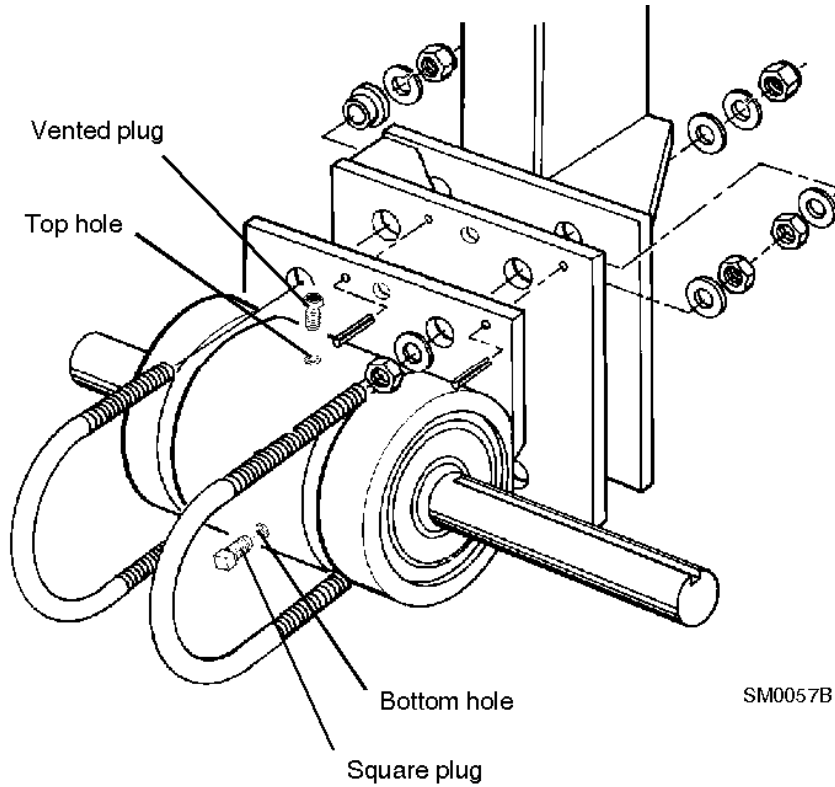

FIG. 4-12

4.15 Up/Down System

1. Grease the up/down gear reducer shaft bearing with a NLGI No. 2 grade lithium grease every 1000 hours of operation.

See Figure 4-13.

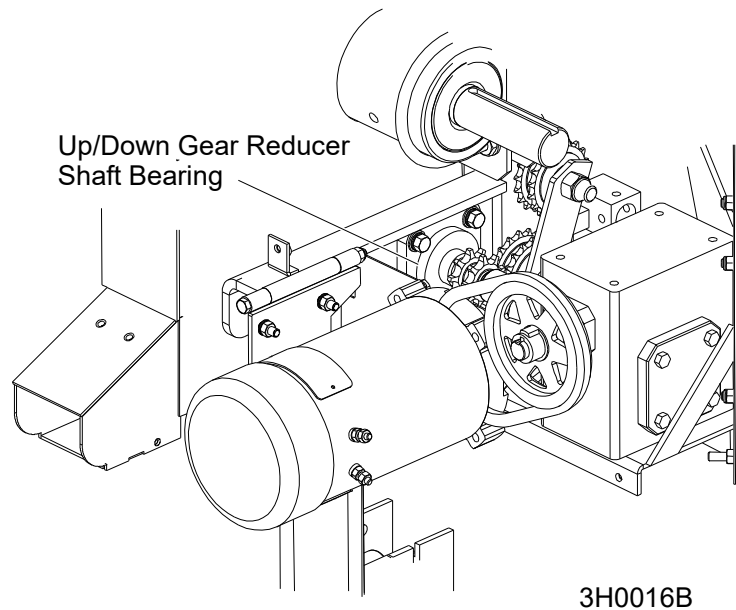



FIG. 4-13

2. Super model up/down systems feature a spring loaded belt design. Belt tension is automatically maintained and requires no adjustment. Replace the belt when adequate belt tension can no longer be obtained.



WARNING! Always secure the cutting head with a chain or a brace before removing the up/down motor belt. The cutting head may fall, causing severe injury or death.

- Adjust the up/down chain tension as needed. Measure chain tension with the head all the way to the top of the vertical mast. Secure the carriage with a chain at the top, or shim it underneath. Find the chain adjusting bolt at the bottom of the mast, behind the battery box. Adjust the bolt until the center of the chain can be deflected 3/4" (1.9cm) forward *and* 3/4" (1.9cm) backward with a 5 lb. (2.3 Kg) deflection force.

 **WARNING!** Always secure the cutting head with a chain or a brace before adjusting the up/down chain. The cutting head may fall, causing severe injury or death.

 **CAUTION!** Do not over-tension the chain. Over-tensioning the chain may lead to early failure of the gear reducer.

See Figure 4-14.

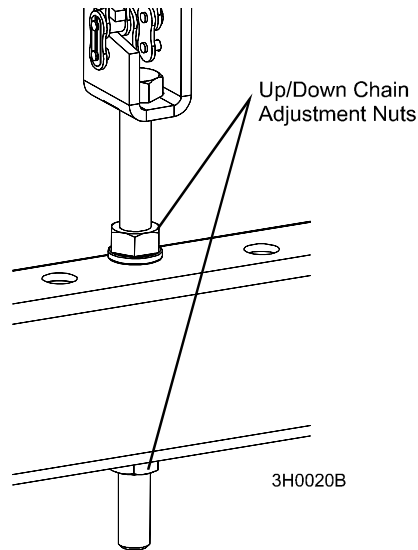
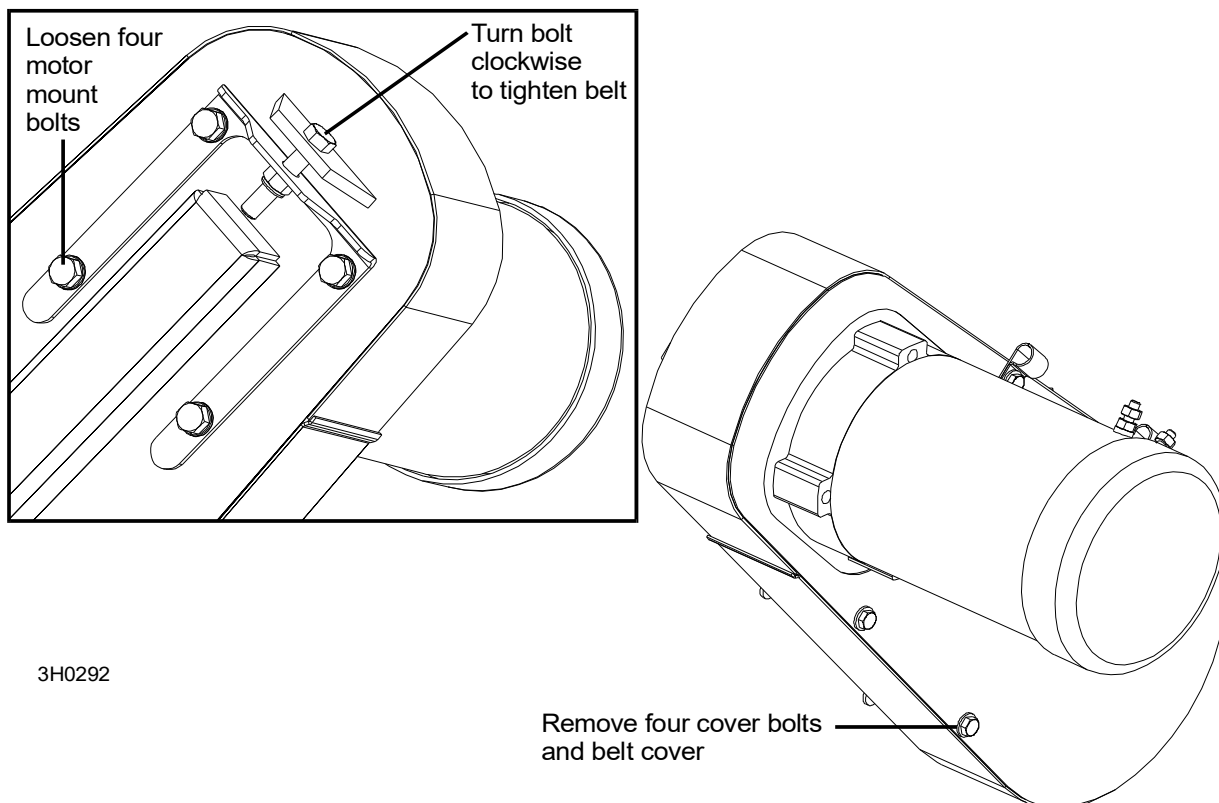

FIG. 4-14

4.16 Power Feed

1. Adjust the power feed belt as needed. When the power feed belt gets loose, it will begin slipping. This causes the carriage to not move forward when cutting. To retighten the belt:

See Figure 4-15. Remove the four cover bolts and belt cover and measure the belt tension. The belt should be tightened so there is 1/8" (3 mm) deflection with a 7 lb. (3.2 Kg) deflection force. To adjust the belt tension, loosen the four motor mount bolts. Place a wrench on the jam nut and turn the adjustment bolt clockwise to tighten the belt. Retighten the motor bolts and replace the feed motor cover.



3H0292

FIG. 4-15

2. Adjust the power feed chain as needed. Measure the power feed chain tension with the saw head all the way toward the front of the mill. Use the two lock nuts at the rear of the mill to tighten or loosen the power feed chain. Adjust the chain until it measures 7 to 8 inches (17.8 to 20.3 cm) from the top of the top rail at its lowest point.



CAUTION! Do not overtighten the feed chain. Damage to the power feed motor may result.

See Figure 4-16.

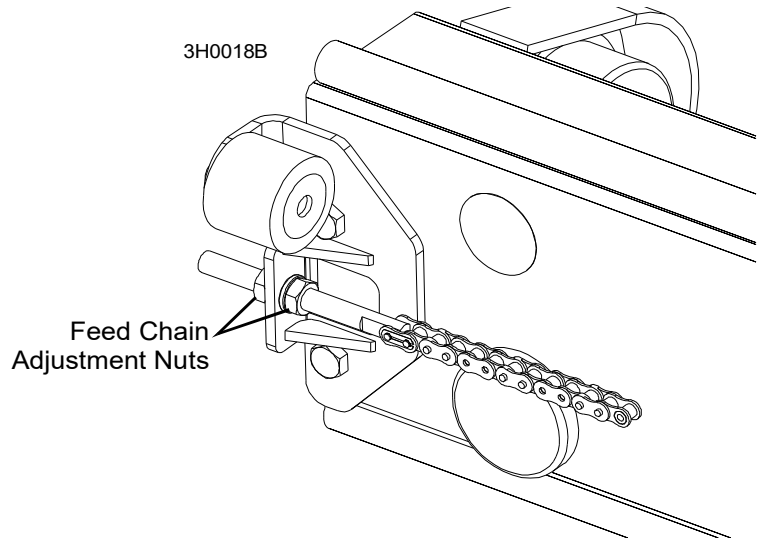

FIG. 4-16

4.17 Safety Devices Inspection

LT40 AC – Safety devices inspection

Safety devices on the LT40AC machine which must be checked before every shift:

- E-STOP button and its circuit inspection
- Inspection of the control circuits with the E-STOP button pressed
- Blade cover safety switches and its circuit inspection
- Motor brake and its circuit inspection

1. E-STOP button and its circuit inspection

- Turn on the blade motor;
- Press the E-STOP button located on the left side of the control box. Blade motor should be stopped. Pressing the START button shouldn't start the motor until the E-STOP button is released.

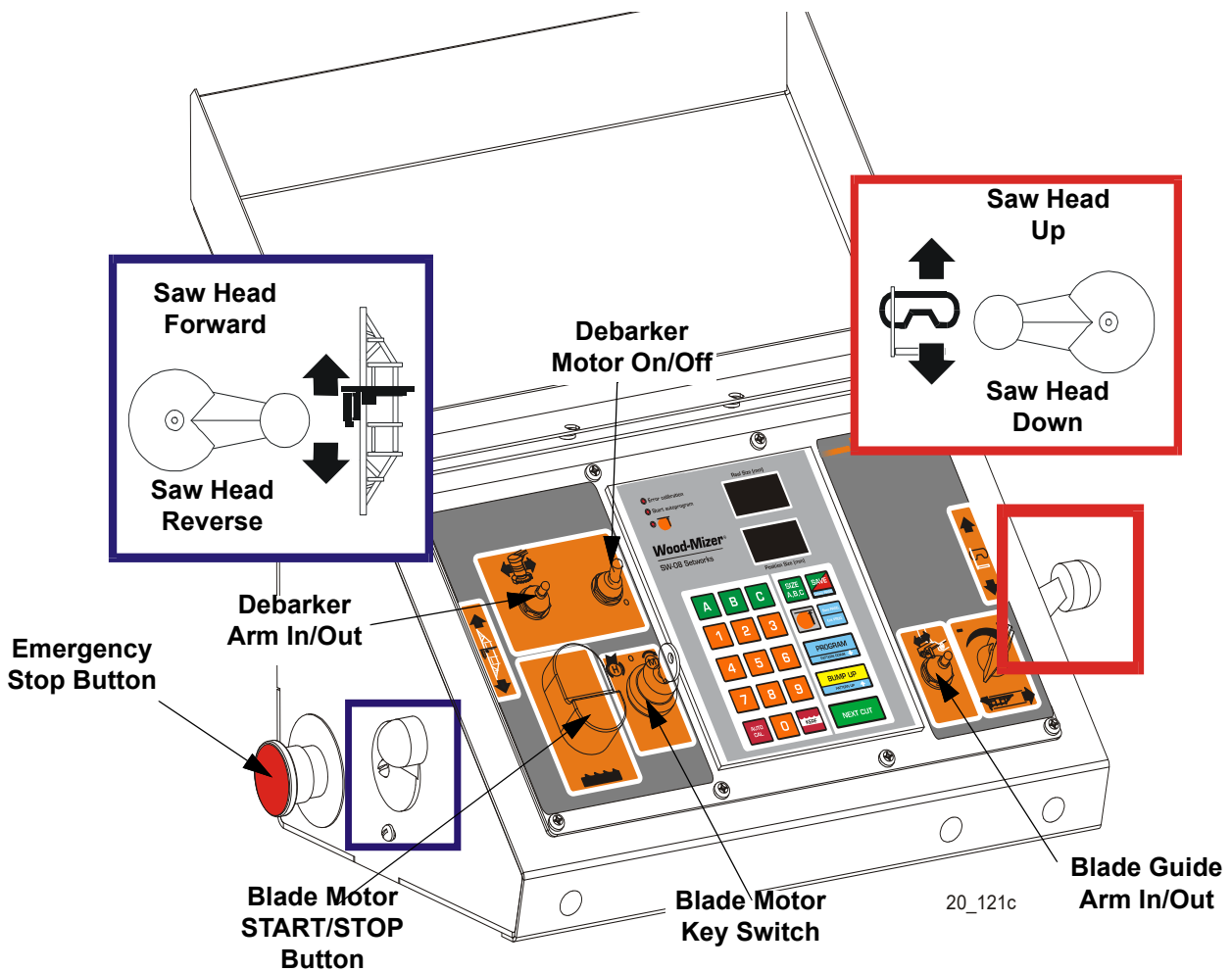

2. Inspection of the control circuits with the E-STOP button pressed

- Turn on the blade motor;
- Press the E-STOP button located on the left side of the control box. Blade motor should be stopped.
- With E-STOP button pressed try to move the saw head up and down (using switch and setwork buttons) and forward/backward using power feed switch. Both systems shouldn't start.
- With E-STOP button pressed try to start the debarker blade motor and move the debarker arm in and out. Debarker shouldn't work.

With E-STOP button pressed try to move the blade guide arm in and out. Blade guide arm shouldn't work.

LT40 DC – Safety devices inspection

Safety devices on the LT40DC machine which must be checked before every shift:

- E-STOP button and its circuit inspection

- Inspection of the control circuits with the E-STOP button pressed
- Blade cover safety switches and its circuit inspection
- Blade brake and its circuit inspection

1. E-STOP button and its circuit inspection

- Start the engine;
- Turn the tensioner handle to engage the blade;
- Press the E-STOP button located on the left side of the control box. Engine should be stopped. Re-starting the engine shouldn't be possible until the E-STOP button is released.

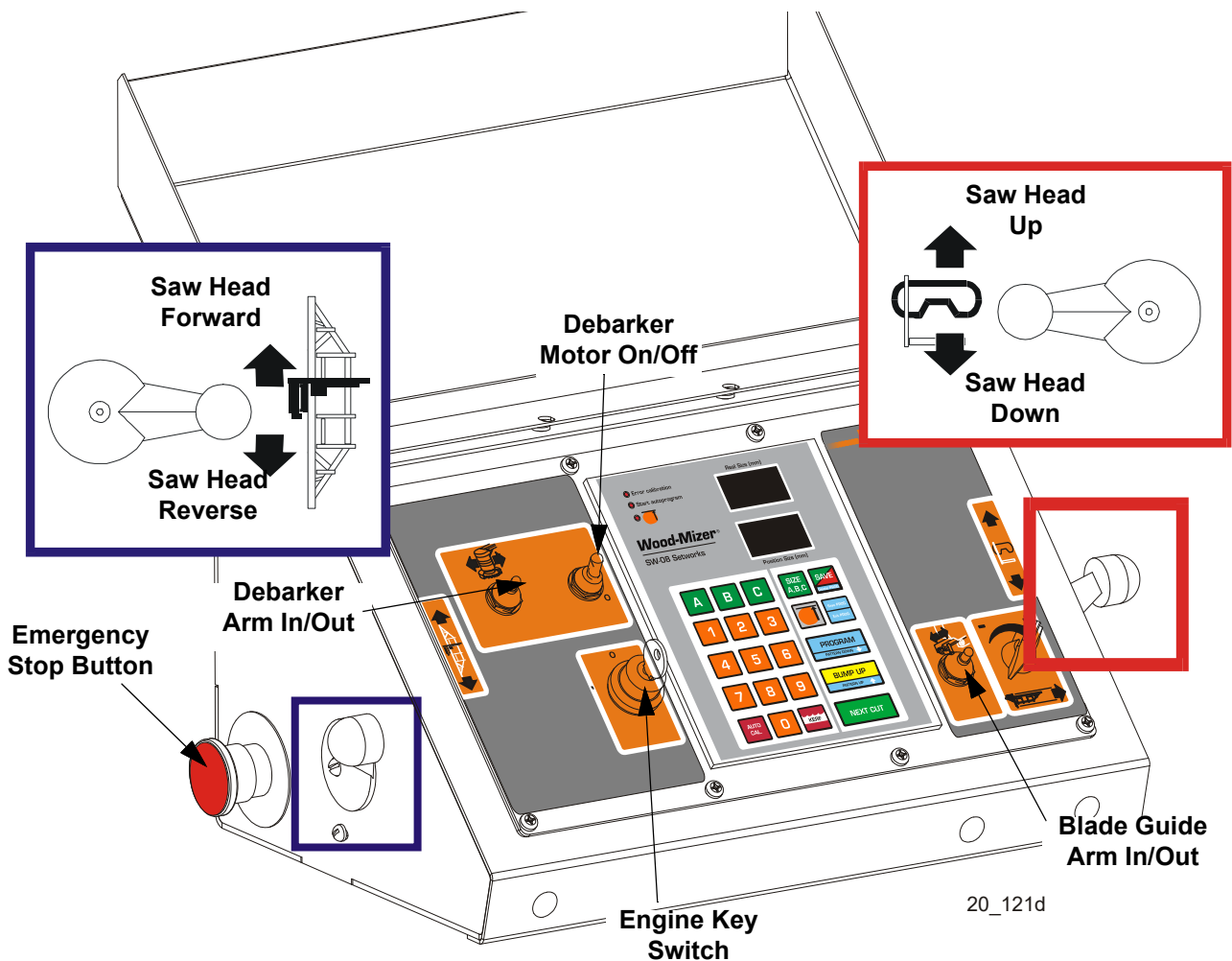

2. Inspection of the control circuits with the E-STOP button pressed

- Start the engine;
- Turn the tensioner handle to engage the blade;

- Press the E-STOP button located on the left side of the control box. Engine should be stopped..
- With E-STOP button pressed try to move the saw head up and down (using switch and setwork buttons) and forward/backward using power feed switch. Both systems shouldn't start.
- With E-STOP button pressed try to start the debarker blade motor and move the debarker arm in and out. Debarker shouldn't work.
- With E-STOP button pressed try to move the blade guide arm in and out. Blade guide arm shouldn't work.
- With E-STOP button pressed try to control the board return arm. Board return arm shouldn't work.

3. Blade cover safety switches and its circuits inspection.

- Start the engine;
- Turn the tensioner handle to engage the blade;
- Open left blade housing cover;
- Engine should be stopped;
- Try to start the engine. The engine should remain stopped;
- Close blade housing cover;
- Engine should remain stopped.
- Re-start the engine
- Turn the tensioner handle to engage the blade;
- Open right blade housing cover;
- Engine should be stopped;
- Try to start the engine. The engine should remain stopped;
- Close blade housing cover;
- Engine should remain stopped.

4. Blade brake and its circuit inspection

- Start the engine;
- Turn the tensioner handle right to engage the blade.
- Stop the engine by switching the key to "0" position. Measure the braking time.

- Re-start the engine. Turn the tensioner handle right to engage the blade.
- Turn the tensioner handle left to stop the blade. Measure the braking time.
- Braking time should always be shorter than 10 seconds. If the braking time is longer it is necessary to adjust or replace brake pads. [See Section 4.9](#)

LT40 Series A/DH Short Interval Maintenance Schedule

(Check engine and option manuals for additional maintenance procedures)

PROCEDURE	MANUAL REFERENCE
EVERY BLADE CHANGE	
Check Blade Guide Roller Performance	See Section 3.2
Remove Excess Sawdust From Blade Wheel Housings And Sawdust Chute	See Section 3.3
Check Blade Screw	See Section 3.2
EVERY 8 HOURS	
Clean And Lubricate Track	See Section 3.4
Remove Sawdust From Upper Cam Housings	See Section 3.4
Clean Sawdust From Hydraulic Loader Fuses, Battery Box Lid & Track Cover	See Section 3.3
EVERY 25 HOURS	
Clean And Lubricate Upper Track Wiper	See Section 3.4

WOOD-MIZER LT40 SERIES A/DH MAINTENANCE LOG

(Check Engine And Option Manuals For Additional Maintenance Procedures)

PROCEDURE	MANUAL REFERENCE	TOTAL HOURS OF OPERATION									
		FILL IN THE DATE AND THE MACHINE HOURS AS YOU PERFORM EACH PROCEDURE. A SHADED BOX INDICATES MAINTENANCE IS NOT NEEDED AT THIS TIME.									
		50 HRS	100 HRS	150 HRS	200 HRS	250 HRS	300 HRS	350 HRS	400 HRS	450 HRS	500 HRS
Clean & lube mast rails	See Section 3.5										
Lubricate drum switches	See Section 3.6										
Grease pivot points and bearings/Oil chains	See Section 3.7 See Section 3.16 See Section 3.17										
Check belt tensions	See Section 3.11 See Section 3.16 See Section 3.17										
Check brake strap tension	See Section 3.10										
Rotate drive/idle blade wheel belts/Check all belts for wear	See Section 3.9										
Check feed & up/down chain tensions	See Section 3.16 See Section 3.17										
Check up/down gear box fluid level	See Section 3.16										
Lubricate blade tensioner handle and rods	See Section 3.8										
Inspect hydraulic lines & fittings	See Section 3.14										
Check hydraulic fluid level	See Section 3.14										
Replace hydraulic system filter	See Section 3.14										
Replace cylinder drive bearing fluid	See Section 3.15										
Inspect hydraulic pump motor brushes	See Section 3.14										
Grease up/down shaft bearing	See Section 3.16										

WOOD-MIZER LT40 SERIES A/DH MAINTENANCE LOG

(Check Engine And Option Manuals For Additional Maintenance Procedures)

PROCEDURE	MANUAL REFERENCE	TOTAL HOURS OF OPERATION									
		FILL IN THE DATE AND THE MACHINE HOURS AS YOU PERFORM EACH PROCEDURE. A SHADED BOX INDICATES MAINTENANCE IS NOT NEEDED AT THIS TIME.									
		550 HRS	600 HRS	650 HRS	700 HRS	750 HRS	800 HRS	850 HRS	900 HRS	950 HRS	1000 HRS
Clean & lube mast rails	See Section 3.5										
Lubricate drum switches	See Section 3.6										
Grease pivot points and bearings/Oil chains	See Section 3.7 See Section 3.16 See Section 3.17										
Check belt tensions	See Section 3.11 See Section 3.16 See Section 3.17										
Check brake strap tension	See Section 3.10										
Rotate drive/idle blade wheel belts/Check all belts for wear	See Section 3.9										
Check feed & up/down chain tensions	See Section 3.16 See Section 3.17										
Check up/down gear box fluid level	See Section 3.16										
Lubricate blade tensioner handle and rods	See Section 3.8										
Inspect hydraulic lines & fittings	See Section 3.14										
Check hydraulic fluid level	See Section 3.14										
Replace hydraulic system filter	See Section 3.14										
Replace cylinder drive bearing fluid	See Section 3.15										
Inspect hydraulic pump motor brushes	See Section 3.14										
Grease up/down shaft bearing	See Section 3.16										

WOOD-MIZER LT40 SERIES A/DH MAINTENANCE LOG

(Check Engine And Option Manuals For Additional Maintenance Procedures)

PROCEDURE	MANUAL REFERENCE	TOTAL HOURS OF OPERATION									
		FILL IN THE DATE AND THE MACHINE HOURS AS YOU PERFORM EACH PROCEDURE. A SHADED BOX INDICATES MAINTENANCE IS NOT NEEDED AT THIS TIME.									
		1050 HRS	1100 HRS	1150 HRS	1200 HRS	1250 HRS	1300 HRS	1350 HRS	1400 HRS	1450 HRS	1500 HRS
Clean & lube mast rails	See Section 3.5										
Lubricate drum switches	See Section 3.6										
Grease pivot points and bearings/Oil chains	See Section 3.7 See Section 3.16 See Section 3.17										
Check belt tensions	See Section 3.11 See Section 3.16 See Section 3.17										
Check brake strap tension	See Section 3.10										
Rotate drive/idle blade wheel belts/Check all belts for wear	See Section 3.9										
Check feed & up/down chain tensions	See Section 3.16 See Section 3.17										
Check up/down gear box fluid level	See Section 3.16										
Lubricate blade tensioner handle and rods	See Section 3.8										
Inspect hydraulic lines & fittings	See Section 3.14										
Check hydraulic fluid level	See Section 3.14										
Replace hydraulic system filter	See Section 3.14										
Replace cylinder drive bearing fluid	See Section 3.15										
Inspect hydraulic pump motor brushes	See Section 3.14										
Grease up/down shaft bearing	See Section 3.16										

WOOD-MIZER LT40 SERIES A/DH MAINTENANCE LOG

(Check Engine And Option Manuals For Additional Maintenance Procedures)

PROCEDURE	MANUAL REFERENCE	TOTAL HOURS OF OPERATION									
		FILL IN THE DATE AND THE MACHINE HOURS AS YOU PERFORM EACH PROCEDURE. A SHADED BOX INDICATES MAINTENANCE IS NOT NEEDED AT THIS TIME.									
		1550 HRS	1600 HRS	1650 HRS	1700 HRS	1750 HRS	1800 HRS	1850 HRS	1900 HRS	1950 HRS	2000 HRS
Clean & lube mast rails	See Section 3.5										
Lubricate drum switches	See Section 3.6										
Grease pivot points and bearings/Oil chains	See Section 3.7 See Section 3.16 See Section 3.17										
Check belt tensions	See Section 3.11 See Section 3.16 See Section 3.17										
Check brake strap tension	See Section 3.10										
Rotate drive/idle blade wheel belts/Check all belts for wear	See Section 3.9										
Check feed & up/down chain tensions	See Section 3.16 See Section 3.17										
Check up/down gear box fluid level	See Section 3.16										
Lubricate blade tensioner handle and rods	See Section 3.8										
Inspect hydraulic lines & fittings	See Section 3.14										
Check hydraulic fluid level	See Section 3.14										
Replace hydraulic system filter	See Section 3.14										
Replace cylinder drive bearing fluid	See Section 3.15										
Inspect hydraulic pump motor brushes	See Section 3.14										
Grease up/down shaft bearing	See Section 3.16										



SECTION 5 TROUBLESHOOTING GUIDE

5.1 Sawing Problems

PROBLEM	CAUSE	SOLUTION
Blades Dull Quickly	Dirty logs	Clean or debark logs, especially on entry side of the cut
	When grinding teeth, heating too much and causing teeth to soften	Grind just enough metal to restore sharpness to the teeth. Use water/coolant while sharpening blade
	Poor sharpening techniques	Make sure the tip is being sharpened completely (See Sharpener Manual)
Blades Break Prematurely	Rubber belts on blade wheels worn to a point that blade contacts metal pulley - look for shiny spots on edge of wheels	Change blade wheel belts (B-57)
	Poor sharpening techniques	See Sharpener Manual
	Tension too tight	Tension blade to recommended specifications
Blade Does Not Track Right on Drive Wheel	Cant adjustment is incorrect	Readjust
	Flat/worn belts	Replace B-57 belts
Blade Guides Do Not Spin While Cutting	Frozen bearings	Replace bearings
	Stiff bearings	Grease bearings
Drive Belts Wear Prematurely or Jump	Engine/motor and drive pulleys out of alignment	Align pulleys See Section 5.4 Motor and Drive Pulleys Alignment.

5 Troubleshooting Guide

Sawing Problems

PROBLEM	CAUSE	SOLUTION
Boards Thick Or Thin On Ends Or Middle Of Board.	Stress in log which causes log to not lay flat on the bed.	After log has been squared, take equal cuts off opposing sides. Take a board off the top. Turn the log 180 degrees. Take a board off. Repeat, keeping the heart in the middle of the cant, and making it your last cut.
	Set in teeth.	Resharpen and reset blade.
Height Adjustment Jumps or Stutters When Moving Up or Down.	Bed rails misaligned.	Realign sawmill.
	Mast needs lubrication.	Lubricate mast track surface.
	Up/down chain improperly adjusted.	Adjust up/down chain.
Lumber Is Not Square	Vertical wear pads are too tight.	Adjust pads.
	Drive belt(s) loose.	Adjust belts.
	Vertical side supports not square to bed	Adjust side supports.
Sawdust Builds Up On Track	Blade not parallel to bed rails	Adjust bed rails parallel to blade.
	Sawdust or bark between cant and bed rails	Remove particles
	Tooth set problems	Resharpen and reset blade
Wavy Cuts	Excessive oiling	Do not oil track
	Track wipers worn	Adjust wipers to firmly contact track
	Track is sticky	Clean track with solvent and apply silicone spray
Wavy Cuts	Excessive feed	Slow feed rate
	Improperly sharpened blade (This will be the problem 99% of the time!)	Resharpen blade (See Sharpener Manual - read entire manual!)
	Blade guides improperly adjusted	Adjust blade guides.
Wavy Cuts	Sap buildup on blade	Use Water Lube.
	Tooth set problem	Resharpen and reset blade

5.2 Electrical Problems

PROBLEM	CAUSE	SOLUTION
Up/down Excessively Slow.	Vertical wear pads too tight.	Adjust pads.
	Up/down belt loose.	Adjust belt to be as loose as possible without slipping
Up/down Or Power Feed Motors Do Not Work.	Worn/dirty contacts in drum switch.	Replace switch or remove control panel cover and clean contacts.
	Bad key switch.	Replace key switch.
	Circuit breaker.	Reset breaker in control box.
	Burned-out motor.	Replace motor.
	Bad connection on battery post or loose wire.	Check for loose wire or terminal connections.
	Up/down motor relay damaged.	Have a qualified electrician replace the relay.
	Up/down motor is damaged.	Have a qualified electrician replace the up/down motor.
	One phase lacks.	Check circuit breakers in the connectors.
	Motor thermal protector started to work.	Let the motor cool and then reset the thermal protector.
	Speed switch circuit overloaded.	Turn off the power and let the motor cool. Turn the power back on.
Power Feed Motor Does Not Work.	Power feed is overheated.	Turn off the power and let the motor cool. Turn the power back on.
	Short circuit in speed switch motor system.	Have a qualified electrician remove the short circuit.
	Sawdust buildup in the power feed pulleys.	Sawdust buildup puts mechanical bind on power feed which causes automatic motor protection circuit to activate. Remove sawdust from pulleys and operate normally. If motor does not operate after sawdust removal, reset 70 amp circuit breaker on the front of the control box.

5 Troubleshooting Guide

Electrical Problems

Up/Down Or Power Feed Switches Remain Engaged When Switch Is Released.	Worn or dirty contacts in drum switch.	Manually move the power feed or up/down switch back to neutral or "off" position. Replace drum switch or remove control panel cover and clean and lubricate contacts NOTE: Use only contact grease supplied by Wood-Mizer.
	Drum switch spring broken.	Manually move the power feed or up/down switch back to neutral or "off" position. Replace drum switch spring.
Up/Down Or Power Feed Motors Overheat And Loose Power.	System overload or bind occurred.	Correct problem. See Section 5.3 Power Feed Problems. Allow motor to cool before restarting.
	Normal operation factors exceeded (eg: up/down control jockeyed excessively).	Allow motor to cool before restarting.
Everything Works And Then Cuts Out - Works Again.	Bad fuse, or ground connection.	Check and tighten connections.
Nothing Works Electrically.	Blown fuse.	Replace.
Intermittent Or Permanent Loss Of Accessory Motor Functions Occurs (Up/down, Fwd/rev, Blade Guide Functions Do Not Work).	Bad connections at accessory solenoid or bad solenoid.	Check all connections at accessory solenoid. If connections are good, replace solenoid.

5.3 Power Feed Problems

PROBLEM	CAUSE	SOLUTION
Power Feed Is Jerky At Low Speeds Or Does Not Move Until Speed Is Above Halfway Mark.	Drum switch is dirty.	Clean drum switch and lubricate with contact grease supplied by Wood-Mizer.
	Drum switch contacts are bad	Check that contacts are in good condition and positively close circuit.
	Speed switch is worn.	Replace the speed switch.
Power Feed Is Jerky, But Power Feed Motor Runs Properly At All Speeds.	Speed switch is blocked.	Turn off the power for 20 seconds and turn it back on.
	Problem is mechanical.	Refer to the Mechanical Test.
Power Feed Is Sluggish, Trips Circuit Breaker Or Current Limit.	Sawdust buildup in power feed cover.	Remove power feed belt cover and remove sawdust.

5 Troubleshooting Guide

Power Feed Problems

PROBLEM	CAUSE	SOLUTION
Power Feed Motor Overheats.	Middle track oiler is dragging.	Clean middle track oiler and lubricate with 30-weight oil or ATF (Automatic Transmission Fluid) such as Dexron II. Allow motor to cool before restarting.
	Ground is not level.	Level mill with carpenter's level. Allow motor to cool before restarting.
	Track roller bearing drag is excessive.	Lubricate bearings; Replace tight bearings. Allow motor to cool before restarting.
	Lower track rollers are not aligned properly.	Check stop block clearance from lower bed rail. Allow motor to cool before restarting.
	Chain is dragging.	Make sure chain is centered on cam follower bearing; Clean and lubricate chain; Adjust chain tension. Allow motor to cool before restarting.
	Chain is improperly tensioned.	Adjust chain tension. Allow motor to cool before restarting.
	Seat load is excessive.	Check seat bearings for freedom of movement; Loosen clamping screw 1/4 turn. Allow motor to cool before restarting.
	Power feed is binding.	Adjust belt tension; Check condition of belt, pulleys, bearings, and sprocket; Check motor for ground fault. Allow motor to cool before restarting.
	Saw head load is excessive.	Avoid unnecessary modifications to saw heads that would give them extra weight. Allow motor to cool before restarting.
	Blade is dull or improperly set.	Use proper blade maintenance procedures (See Sharpener or Toothsetter manual). Allow motor to cool before restarting.

5.4 Motor and Drive Pulleys Alignment

1. Install the drive belt.
2. Use a straight edge to align the engine/motor pulley to the drive pulley. Also check that the engine pulley is within 1/8" square with the drive pulley. Loosen the engine mounting bolts and rotate the engine if necessary.
3. Check front-to-back movement of the engine does not exceed 1/4". Tighten the motor mount U-bolts if necessary.
4. Engage the clutch handle and adjust the drive belt tension to 7/16" deflection with 10 lb. of force.
5. Recheck the pulley alignment and engine squareness with the clutch handle engaged. Adjust if necessary.
6. Adjust the drive belt support to 1/4" ($\pm 1/32$) from the belt while engaged.

5.5 Power Feed Variable Speed Switch Test

With the feed rate dial switch all the way down, move the shaft of the dial back and forth to see if there is a jerky response. Turn the dial and move the shaft back and forth again. Repeat several times. If the jerkiness occurs at the same location on the dial several times, you need to replace the variable speed switch.

5.6 Power Feed Preliminary Test

This test will determine if the problem is a mechanical or electrical.

1. Remove the drive belt from the power feed drive pulley.
2. Turn the key switch to the (#2) position. Put the carriage forward/reverse switch into the forward position and turn the feed rate dial through all speeds. If the power feed motor runs properly at all speeds, the problem is a mechanical one instead of an electrical one.

5.7 Power Feed Mechanical Test

1. Remove the weight from the track rollers. They should turn smoothly and easily with very little play.
2. Make sure the middle track cover is not bent or touching the top rail.
3. Make sure the middle track oiler is free of sawdust buildup.
4. Make sure the power feed chain is not stiff from rust. Also make sure the chain is not too tight.
5. Check the power feed shaft. Visually inspect the bearings. The shaft should move neither in or out nor side to side.
6. Make sure the power feed chain cam bearing is not touching the main frame tube.
7. Make sure there is no sap or rust on the rails.
8. Make sure the block on the lower track roller assembly is not rubbing the lower rail. Also make sure the track rollers are not too tight.
9. Make sure the power feed belt is properly tightened.

SECTION 6 SAWMILL ALIGNMENT

6.1 Pre-Alignment Procedures

The Wood-Mizer sawmill is factory aligned. Two alignment procedures are available to realign the sawmill if necessary. The Routine Alignment instructions should be performed as necessary to solve sawing problems not related to blade performance. The Complete Alignment procedure should be performed approximately every 1500 hours of operation (sooner if you regularly transport the sawmill over rough terrain).

Routine Alignment Procedure:

1. Install and track the blade ([See Section 6.3](#)).
2. Check the angle of the blade in relation to the bed rails and adjust the lower track rollers if necessary ([See Section 6.15](#)).
3. Check and adjust the vertical alignment of the blade guide arm ([See Section 6.7](#)).
4. Check and adjust the horizontal alignment of the blade guide arm ([See Section 6.8](#)).
5. Check and adjust the vertical angle of the blade guides ([See Section 6.9](#)).
6. Check and adjust the horizontal angle of the blade guides ([See Section 6.11](#)).
7. Check and adjust the spacing between the blade guide flanges and the back of the blade ([See Section 6.10](#)).
8. Check and adjust the horizontal angle of the side supports ([See Section 6.13](#)).
9. Check and adjust the vertical angle of the side supports ([See Section 6.14](#)).
10. Check that the blade height scale accurately displays the actual distance from the bottom of the blade to the bed rails and adjust if necessary ([See Section 6.16](#)).

Complete Alignment Procedure:

Perform all steps in this section to completely realign the sawmill.



Sawmill Alignment

Frame Setup

6.2 Frame Setup

Stationary sawmills should be setup on firm, level ground before proceeding with alignment. Shim the feet so the weight of the sawmill is evenly supported.

6.3 Blade Installation And Alignment

See **Figure 6-1**. Install a blade and apply the appropriate tension ([See Section 2.5](#)). Blade tension is adjusted with the tension handle shown.

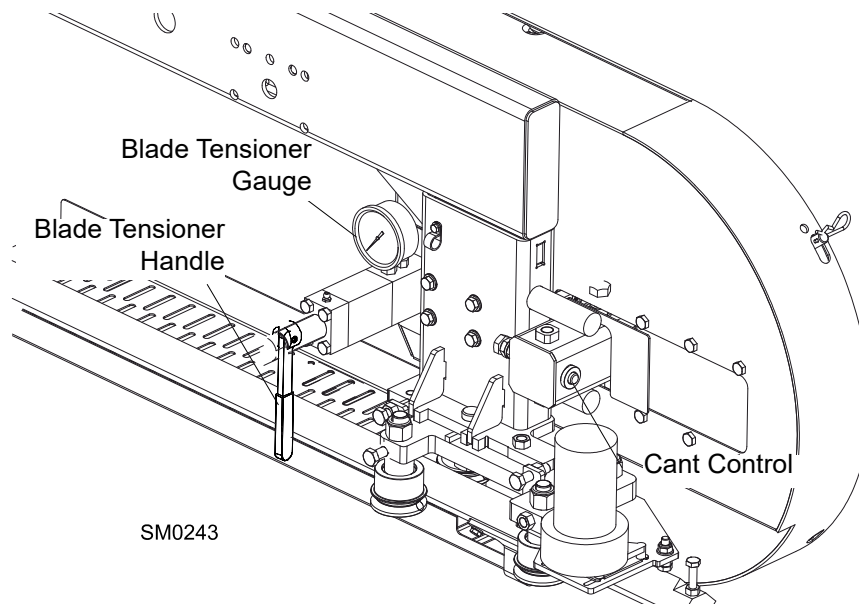

FIG. 6-1

1. Raise the middle blade housing cover and make sure all persons are clear of the open side of the saw head.
2. Turn the key switch to pos. #2.
3. Manually spin idle pulley
4. Remove the key and check the position of the blade on the blade wheels.

Check the vertical alignment of the idle-side blade wheel. The gullet of the blade should ride the same distance from the front edge of the wheel at the top and bottom of the wheel. If it does not, loosen and tighten the appropriate adjustment screws on the wheel shaft.

6

Sawmill Alignment

Blade Installation And Alignment

See **Figure 6-2**. The blade wheels should be adjusted so that the gullet of 1 1/4" blades ride 3.0 mm (0.12") out from the front edge of the wheels (± 1.0 mm [0.04"]). The gullet of 1 1/2" blades should ride 4.5 mm (0.18") from the front edge of the wheels (± 1 mm [0.04"]). Do not let the teeth ride on the wheels.

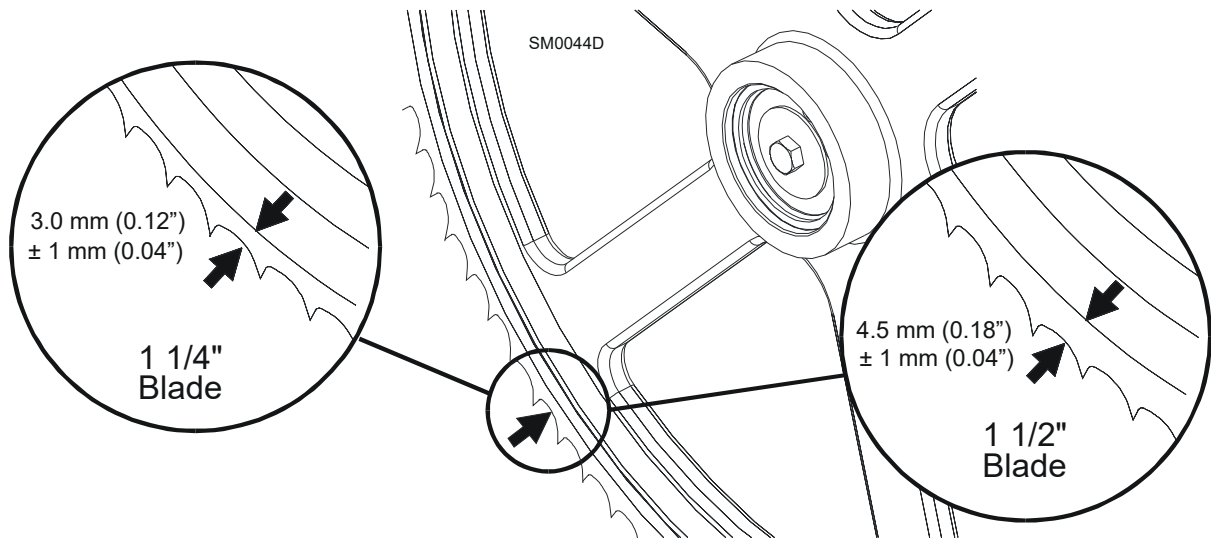

FIG. 6-2

To adjust where the blade travels on the idle-side blade wheel, use the cant control shown in **Figure 5-1**.

If the blade is too far forward on the wheels, turn the cant control counterclockwise. If it is too far back on the wheels, turn the cant control clockwise.

Some adjustment in blade tension may be needed to compensate for adjustments made with the cant control.

Adjustment with the cant control is usually all that is required to track the blade properly on both blade wheels. The drive-side blade wheel will usually not have to be adjusted. If necessary, the drive-side wheel can be adjusted as follows:

See Figure 6-3. For horizontal adjustment, use the horizontal adjustment nuts. If the blade is running too far back on the drive-side blade wheel, locate the long U-bolt on the right which mounts the bearing housing to the mounting plates. Loosen the hex nuts on the U-bolt (on the back side of the back plate). Tighten the adjustment nuts to spread the plates apart and bring the blade forward.

If the blade is running too far to the front, loosen the jam nuts on the long U-bolt and back the adjustment bolts out. Tighten the hex nuts on the long U-bolt (on the back side of the back plate).

Be sure to tighten all nuts against the mounting plates when the adjustment is complete.

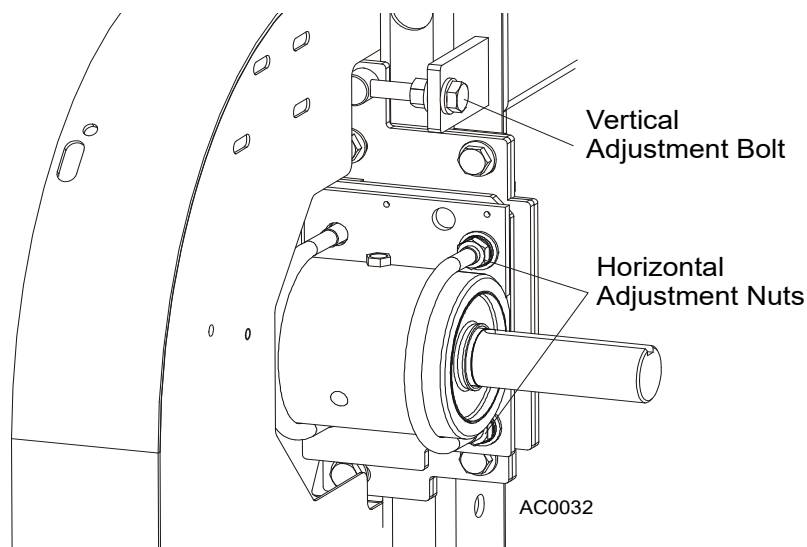

FIG. 6-3

The vertical angle of the drive side wheel is factory-set and should not need to be adjusted. If adjustment is needed, use the vertical adjustment bolt. To tilt the wheel upward, loosen the jam nut and turn the vertical adjustment bolt clockwise. To tilt the wheel downward, loosen the jam nut and turn the vertical adjustment bolt counterclockwise. Be sure to tighten the jam nut.

6.4 Saw Head Slide Pad Adjustment

There are eight nylon pads positioned between the saw head frame and vertical mast. The spacing of the pads is factory set and rarely needs adjusting. To check the pad spacing, perform the following steps.

NOTE: The pads on the engine side of the mast are referred to as the "inner" pads. The pads on the control side of the mast are referred to as the "outer" pads.

NOTE: Shims are often used around the clamping bolts, between the C-frame support bracket and the mast v-brace. The shims align the v-brace to the mast so that the entire face of each slide pad makes contact with the mast. Be sure to keep these shims in place when performing the following adjustment.

See Figure 6-4.

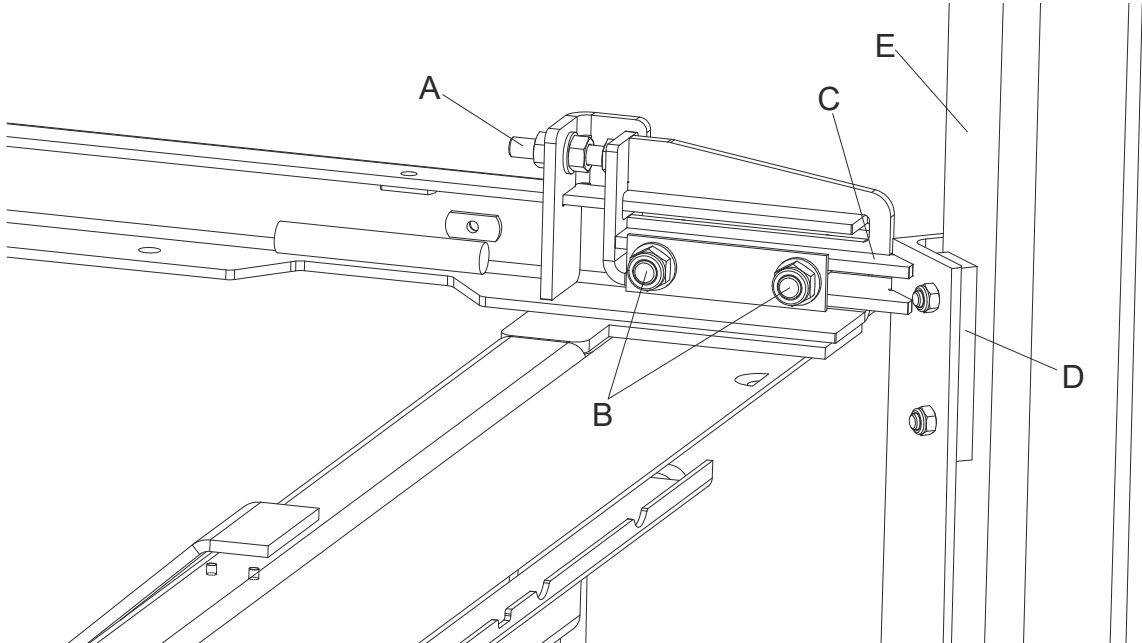

FIG. 6-4

1. Raise the saw head to the top of the vertical mast and secure the saw head with a chain at the top, or shim it underneath. Check the top set of four pads. The outer two pads should be touching the mast rails. There should be a small gap (just wide enough to slide a business card through) between one of the inner pads and the mast rail.



WARNING! Always secure the cutting head with a chain or a brace before adjusting the mast pads. The cutting head may fall, causing severe injury or death.

2. To adjust the spacing of the upper set of pads, lower the saw head until you can access the upper slide pad adjustment bolts.
3. Loosen the upper locking bolts and turn the adjusting bolt as necessary to provide the pad spacing described in Step 1.
4. Lower the saw head to the bottom of the vertical mast. Check the bottom set of four pads.

There should be a small gap between one of the outer pads and the mast rail. The gap should be just wide enough to slide a business card through. The inner two pads should be touching the mast rails. To adjust the spacing of the lower set of pads, raise the saw head until you can access the lower slide pad adjustment bolts.

5. Loosen the lower locking bolts and turn the adjusting bolt as necessary to provide the pad spacing described in Step 4.



CAUTION! Due to variations in the vertical mast, the pad spacing may vary throughout the travel of the saw head. Check the pad spacing at the top and bottom ends of the mast only. Pads adjusted too tight will cause premature up/down motor failure.

6.5 Adjusting The Lower Track Rollers

6

Sawmill Alignment

Adjusting The Lower Track Rollers

See Figure 6-5. Making these adjustments correctly will give you square cuts and accurate dimensions across the width of your boards.

1. Using the feed controls, move the saw carriage so that the blade is positioned over the front pivot end rail.
2. Check the lower roller on the bottom track rail. Make sure that the bottom rollers touch the bottom rail but remain loose enough that you can turn them with your finger. Use the vertical bolts to adjust the bottom track rollers.
3. Check the inside lower rollers. Both inside rollers should touch the rail so that you cannot spin them by hand. If the rollers are not adjusted evenly and you can spin either one, adjust the horizontal nuts until the roller cannot be spun by hand. Check the other roller and adjust if necessary. Adjust both inside rollers until each evenly supports the carriage and you cannot spin either by hand.
4. Move the carriage forward until the blade is positioned over the rear pivot end rail. Repeat steps 2 & 3 until all lower rollers are adjusted properly at the front and rear of the sawmill.

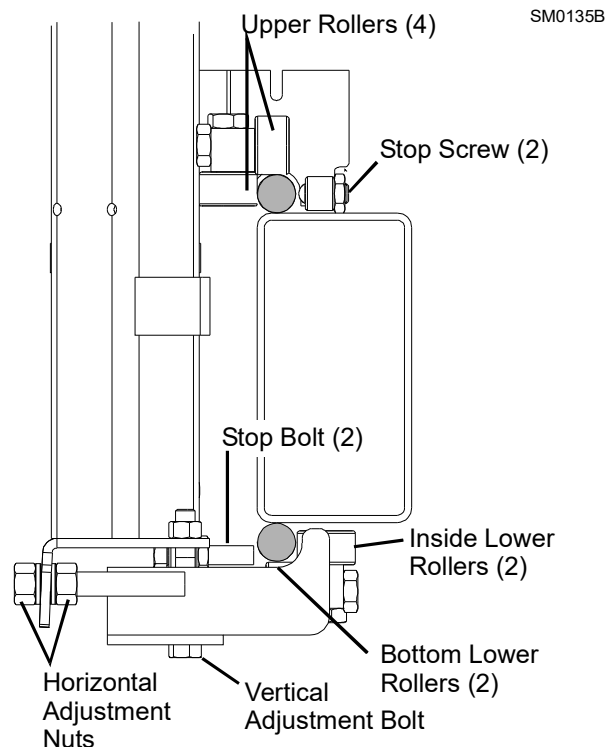

FIG. 6-5

5. Remove the blade guides, or adjust them so that they do not touch the blade.

6. Open the adjustable blade guide arm to within 1/2" (15 mm) of full open.
7. Move the carriage back to the front pivot end rail. Raise the cutting head until the bottom of the blade is 17" (400 mm) above the outside of the pivot rail support by actual measurement with a tape or ruler.

6

Sawmill Alignment

Adjusting The Lower Track Rollers

See Figure 6-6.

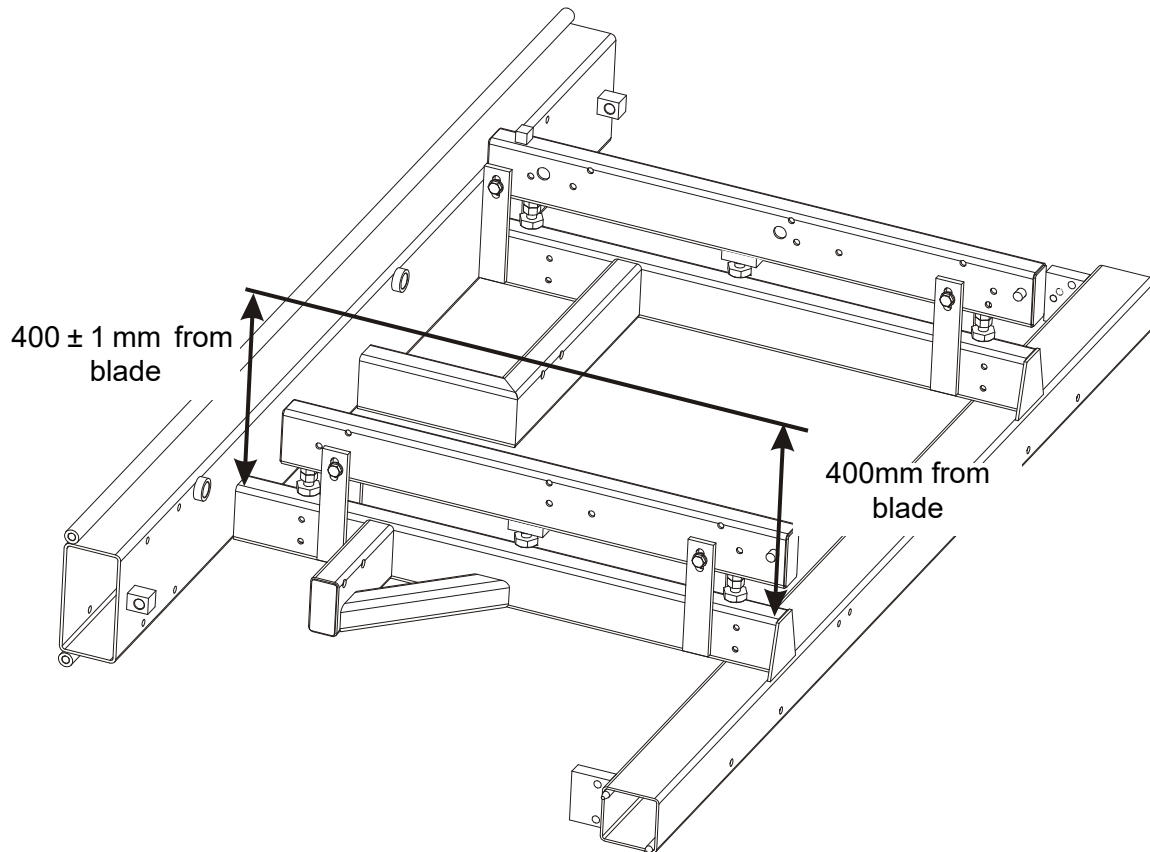

FIG. 6-6

8. Move the carriage forward to check the distance to the blade at the inside of the pivot rail support. All measurements should be equal within ± 1.0 mm.
9. Turn the horizontal adjustment nuts evenly to adjust the inner lower rollers to tilt the saw head until the blade is parallel (± 1.0 mm) to the pivot rail support on the outside.

NOTE: Adjustments of the lower track rollers change the angle between the cutting head and sawmill bed rails. Only small adjustments of the lower track rollers should ever be needed.

10. After the lower track rollers are adjusted properly, adjust the upper and lower stop screws. Tighten each screw until it just touches the rail. Then, back the screw off 1/2 turn. The gap will be approximately 2.0 mm.



CAUTION! It is important that the lower stop bolts are properly adjusted to secure the carriage on the track rail. Failure

to properly adjust the stop bolts can cause saw head damage, especially during mill transportation.

6.6 Adjusting Bed Rails To The Blade

1. Move the cutting head so the blade is positioned over the center of the front main bed rail.
2. Measure the distance between the bottom of the blade and the bed rail at each end of the bed rail. The bed rail should measure 15" (375 mm) (+ 1.0 mm on the outer end) from the blade at each end of the rail.

See Figure 6-7.

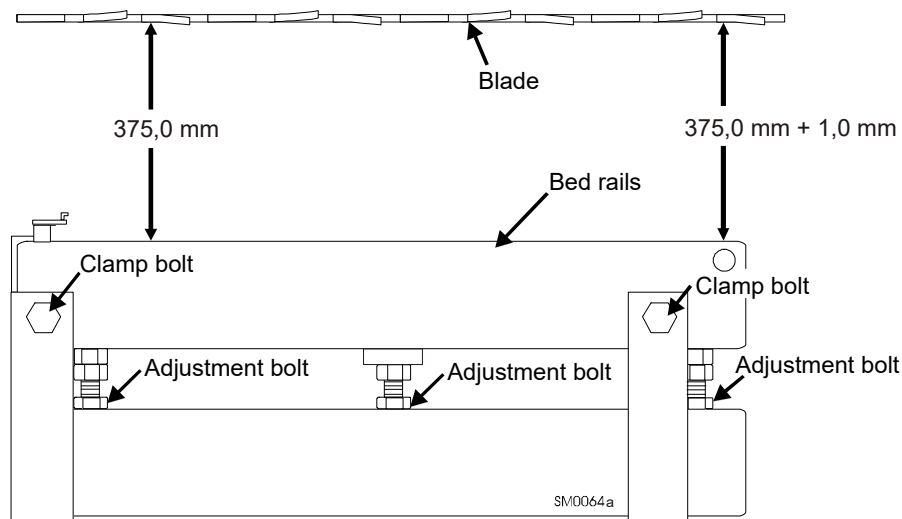

FIG. 6-7

3. Loosen the bed rail clamping bolts and turn the adjustment bolts to move the bed rails to the blade if necessary.
4. Retighten the clamping bolts and adjustment bolts.
5. Without adjusting the cutting head height, check the four main bed rails. Adjust them so that all measure the same distance from the blade at both ends of the bed rail.

6.7 Blade Guide Arm Alignment

Each Wood-Mizer sawmill has two blade guide assemblies that help the blade maintain a straight cut. The two blade guide assemblies are positioned on the saw head to guide the blade on each side of the material being cut.

One blade guide assembly is mounted in a stationary position on the drive side of the saw head. This assembly is referred to as the "inner" blade guide assembly.

The other blade guide assembly is mounted on the idle side of the saw head. It is referred to as the "outer" assembly and is adjustable for various widths of materials to be processed.

Blade guide alignment includes four steps:

- Blade Deflection
- Blade Guide Vertical Tilt
- Blade Guide Flange Spacing
- Blade Guide Horizontal Tilt

Perform the blade guide alignment after you have aligned the blade on the wheels and adjusted the blade and blade guide arm parallel to the bed rails. After blade guide alignment, check the scale indicator to make sure it is adjusted properly.

NOTE: During blade guide alignment, remove the blade guide adjusting screws and apply a lubricating oil such as 10W30 or Dexron III to each screw. This will prevent the screws and threaded holes from corroding and make screw adjustments easier.

1. Adjust the blade guide arm in to 1/2" (15 mm) from fully closed.
2. Manually try to move the arm up and down. If you can move the arm by hand, you will need to tighten the arm rollers.

See Figure 6-8. Loosen the jam nuts and turn the adjustment bolts in to tighten the blade guide arm rollers. Retighten the jam nuts.

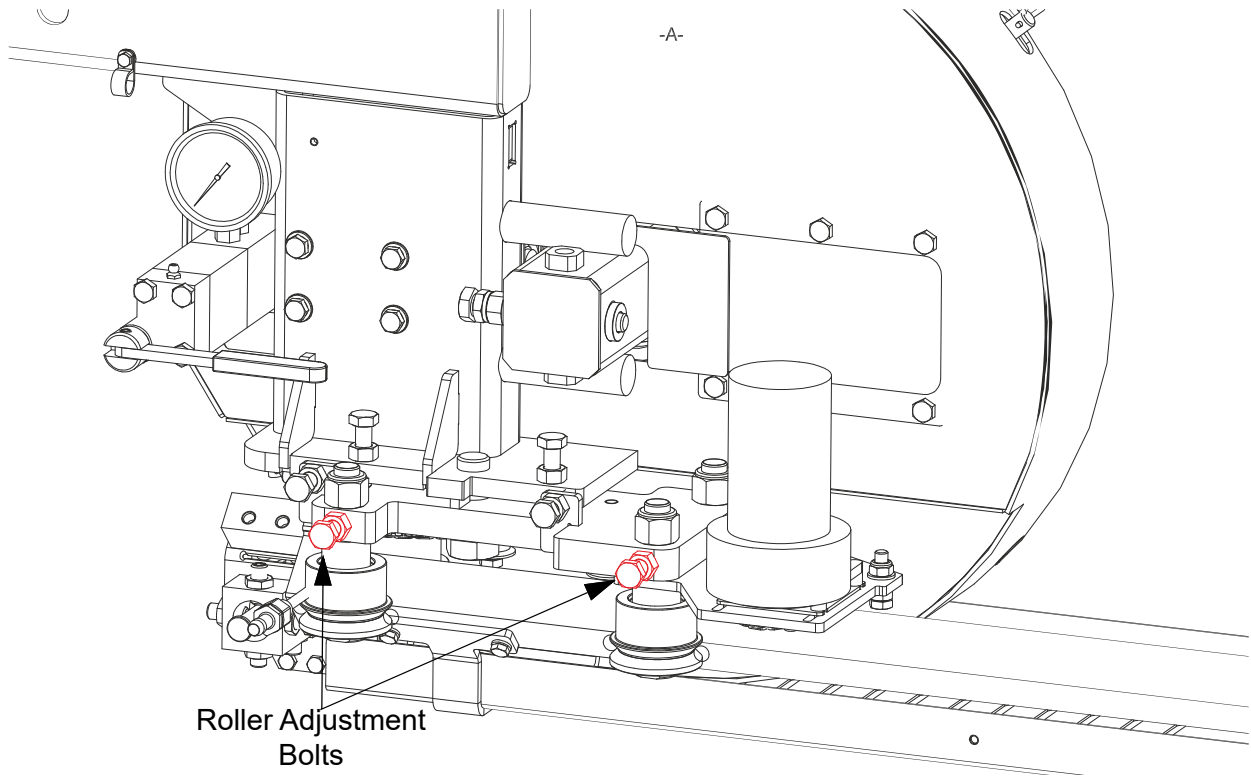

FIG. 6-8

After tightening the blade guide arm rollers, check that the arm is aligned properly.

3. With the arm adjusted 1/2" (15 mm) from fully closed, measure the distance between the rear blade guide roller and the back of the blade.

6 Sawmill Alignment

Blade Guide Arm Alignment

See Figure 6-9.

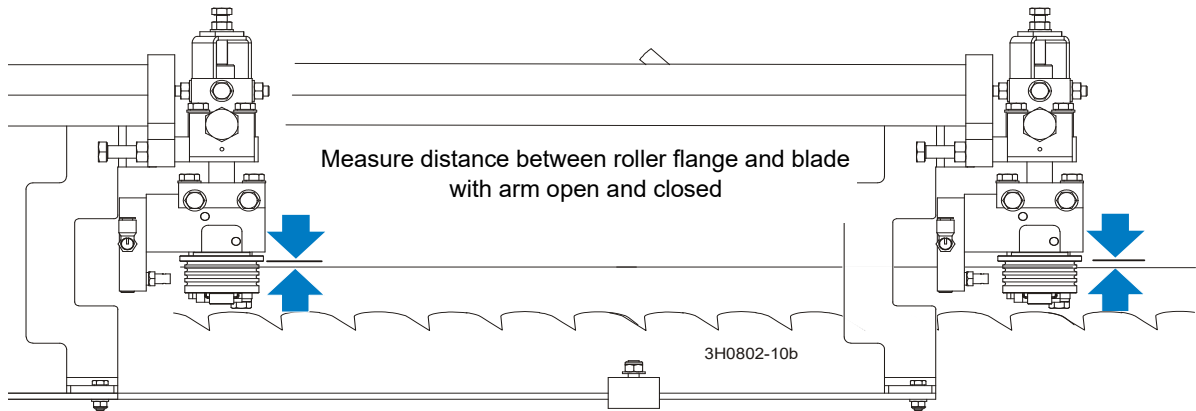

FIG. 6-9

4. Adjust the blade guide arm to 1/2" (15 mm) from fully open and remeasure the distance from the roller flange to the back of the blade. The two measurements should be the same. If not, adjust the outer rollers in or out to tilt the arm horizontally.

See Figure 6-10. Loosen the horizontal adjustment bolt jam nuts. To tilt the arm in toward the blade, loosen the right bolt and tighten the left bolt. To tilt the arm out away from the blade, loosen the left bolt and tighten the right bolt. Retighten the jam nuts and recheck the blade guide arm horizontal tilt.

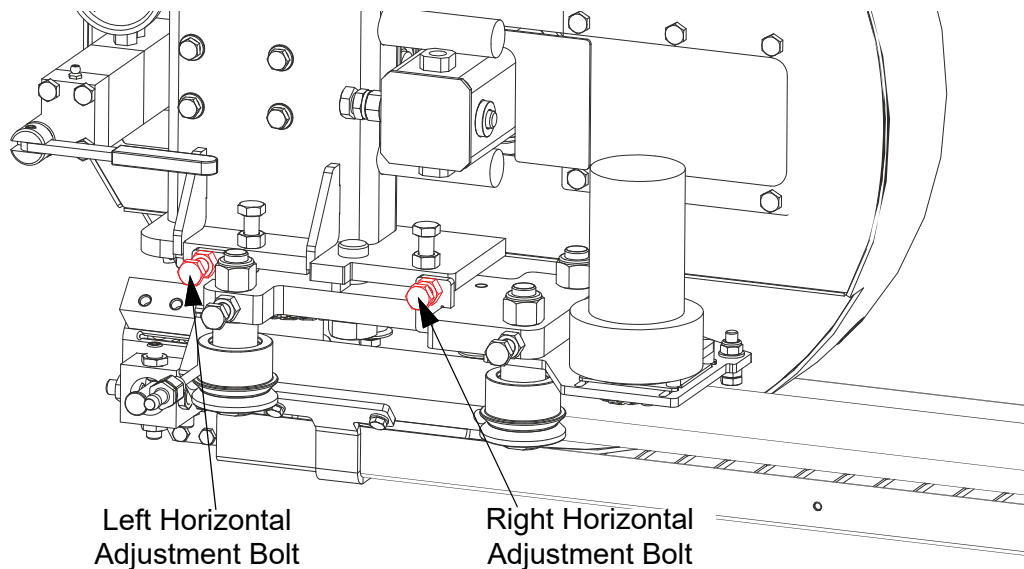

FIG. 6-10

5. Now check the vertical tilt of the blade guide arm. Move the saw head so the blade guide arm is positioned over a bed rail.
6. With the arm 1/2" (15 mm) from fully closed, raise or lower the saw head until the bottom of the blade guide block is 15" (375 mm) from the top of the bed rail (dimension A).

See Figure 6-11.

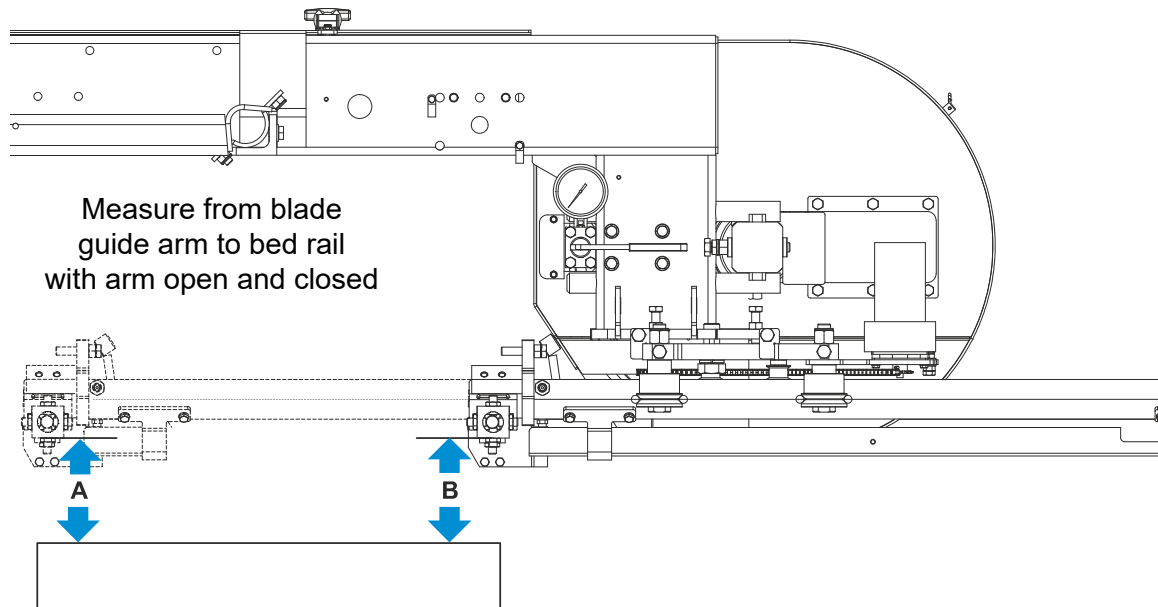

FIG. 6-11

7. Adjust the blade guide arm to 1/2" (15 mm) from fully open. Measure the distance from the bottom of the blade guide mounting block to the bed rail. This measurement should be 15", 375 mm (dimension B) or slightly higher because the saw head is tilted up 1/26" (1 mm) on the outside ([See 6.15 Saw Head Tilt](#)). If the measurement is different, adjust the blade guide arm vertically.

See Figure 6-12. Loosen the vertical adjustment bolt jam nuts. To tilt the blade guide arm down, loosen the right bolt and tighten the left bolt. To tilt the blade guide arm up, loosen the left bolt and tighten the right bolt. Retighten the jam nuts and recheck the blade guide arm vertical tilt.

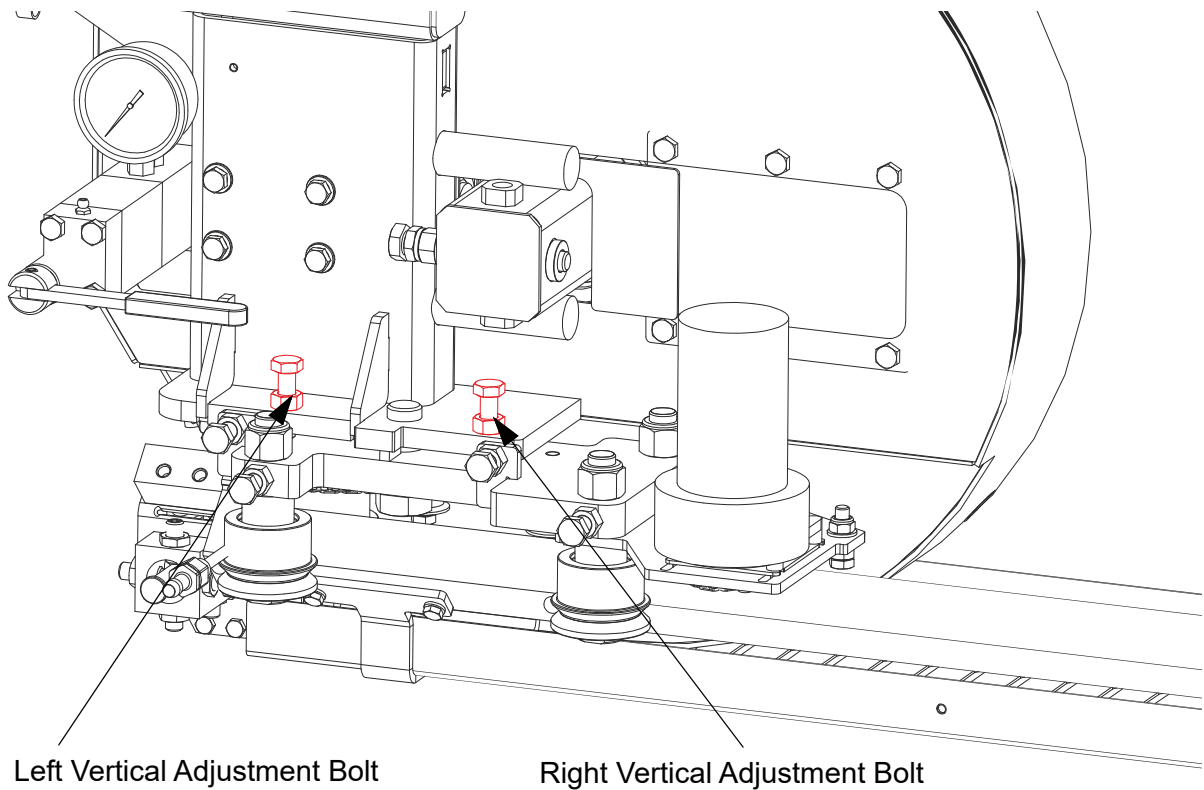

FIG. 6-12



Sawmill Alignment

Blade Deflection

6.8 Blade Deflection

Perform the following steps to achieve proper blade deflection with the blade guides.

1. Raise the carriage until the blade is 15" (375 mm) above a bed rail. Measure the actual distance with a tape from the top of the rail to the bottom of the blade.
2. Install the blade guides. Make sure the two set screws shown are threaded into the blade guide shaft until they touch each other.

See Figure 6-13.

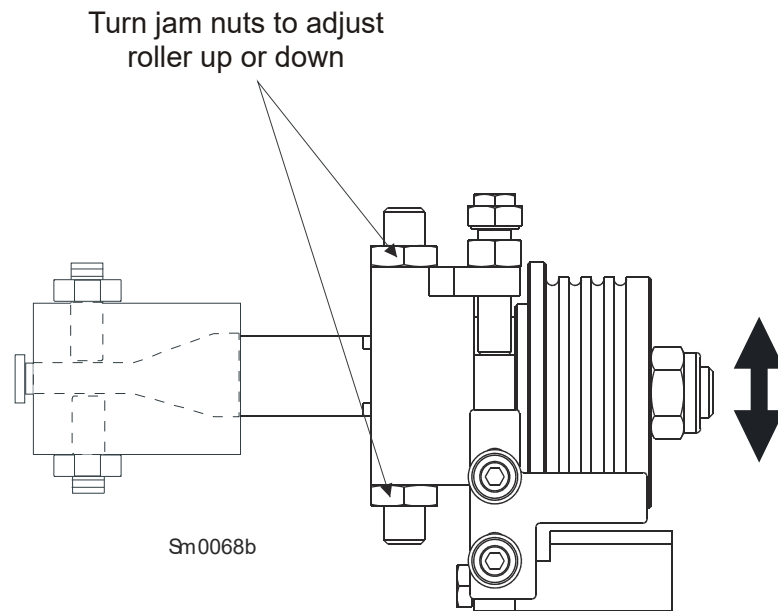

FIG. 6-13

3. Loosen the bottom jam nut and tighten the top jam nut until the blade guide deflects the blade down 4.0 mm.
4. Repeat for the other blade guide.

NOTE: Be sure that the blade guide deflector rod clears the blade on both guide assemblies. The rod on the outer guide assembly should be checked with the arm all the way in and all the way out.

6.9 Blade Guide Vertical Tilt Adjustment

Check that the blade guide does not tilt the blade up or down. A Blade Guide Alignment Tool (BGAT) is provided to help you measure the vertical tilt of the blade.

1. Open the adjustable blade guide arm 1/2" (15 mm) from full open.
2. Clamp the alignment tool on the blade. Position the tool close to a blade guide roller. Be sure the tool does not rest on a tooth or burr, and is lying flat on the blade.

See Figure 6-14.

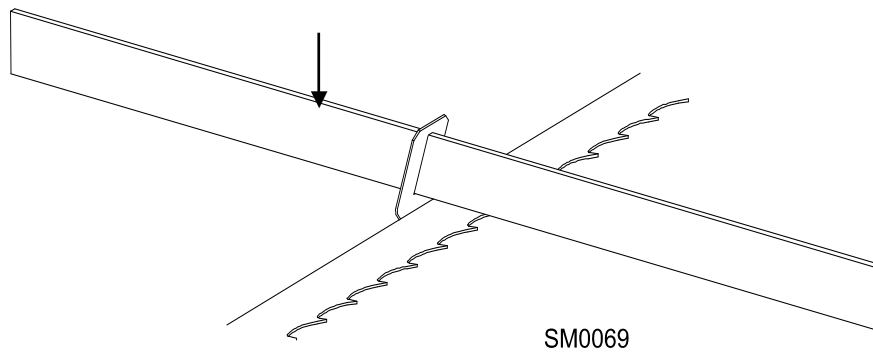

FIG. 6-14

3. Measure the distance from the bed rail to the bottom of the tool.

NOTE: If the sawmill is equipped with stainless steel bed rail covers, be sure to measure from the blade guide alignment tool to the top surface of the cover rather than the bed rail tube.

4. Move the carriage so that the front end of the tool is positioned above the bed rail.
5. Measure the distance from the bed rail to the bottom edge of the tool.
6. Loosen one set screw at the side of the blade guide assembly.
7. Use the set screws shown to tilt the blade guide until the measurement from the bed rail to the tool equals the first measurement taken at the center of the tool.

See Figure 6-15.

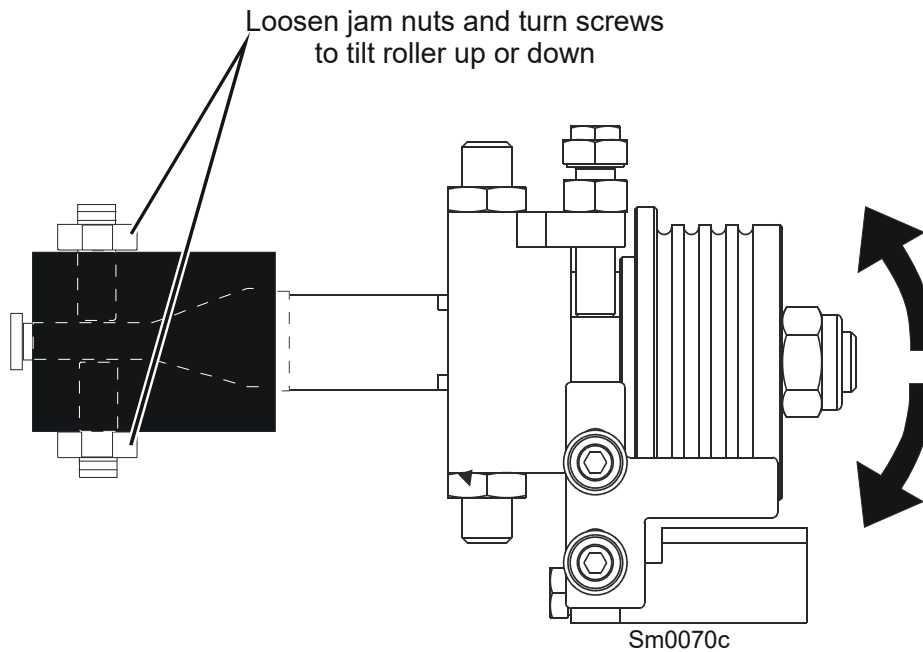

FIG. 6-15

8. Move the carriage forward so the back end of the tool is over the bed rail.
9. Use the set screws shown to adjust the blade guide tilt until the measurement from the bed rail to the tool equals the other two measurements taken.
10. Move the tool close to the other blade guide and repeat the previous steps.

NOTE: If major adjustments to blade guide tilt were made, measure the distance between the blade and the bed rails again to ensure the correct 4.0 mm blade guide deflection. Adjust if necessary.

6.10 Blade Guide Spacing

HINT: When adjusting blade guide spacing, loosen the top set screw and one side set screw only. This will ensure horizontal and vertical tilt adjustments are maintained when the set screws are retightened.

1. Adjust the inner blade guide so the blade guide flange is approximately 3.0 mm from the back of the blade.
2. Loosen one side and one top set screw shown. Tap the blade guide forward or backward until properly positioned.

6 Sawmill Alignment

Blade Guide Spacing

See Figure 6-16.

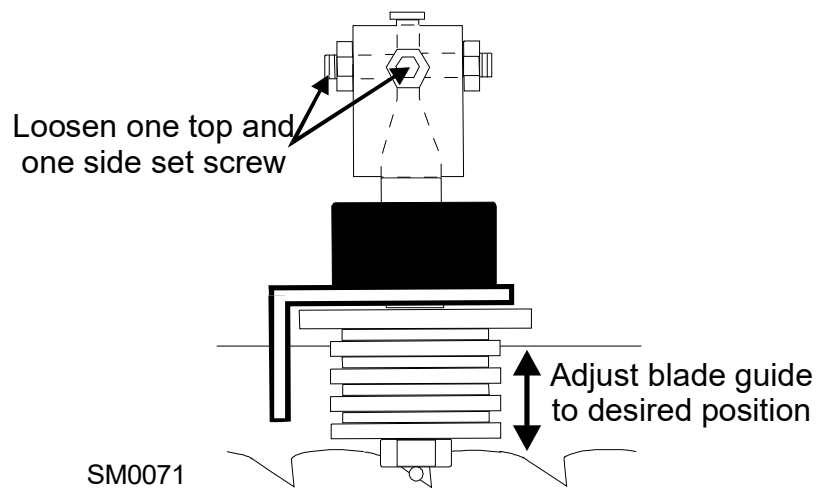

FIG. 6-16

3. Retighten the two set screws.
4. Adjust the outer blade guide in the same way so the blade guide flange is approximately 3.0 mm from the back of the blade.

6.11 Horizontal Tilt Adjustment

1. Finally, both blade guides must be tilted horizontally. Adjust the blade guide arm halfway in.

6 Sawmill Alignment

Horizontal Tilt Adjustment

See Figure 6-17.

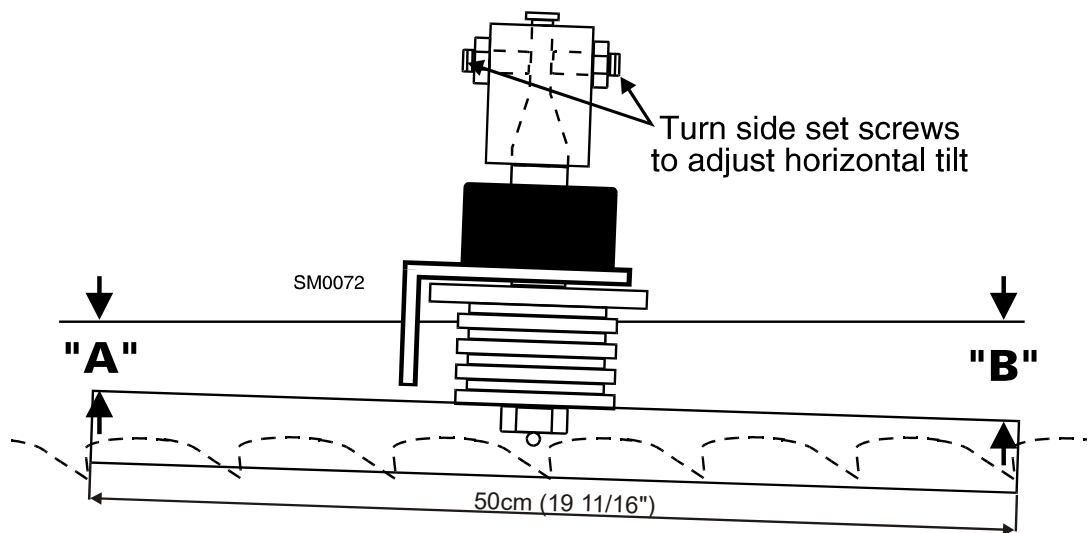

FIG. 6-17

2. Place the Blade Guide Alignment Tool against the face of the outer blade guide roller.
3. Center the tool on the roller and measure between the back edge of the blade and the ruler at the end closest to the inner blade guide ("B").
4. Measure between the back edge of the blade and the other end of the ruler ("A").
5. The roller should be tilted slightly to the left ($A=B-1.4$ " [6 mm]).
6. Use the side set screws to adjust the horizontal tilt of the roller.
7. Repeat steps 3-7 for the inner blade guide roller.

NOTE: Once the blade guides have been adjusted, any cutting variances are most likely caused by the blade. **See the Blade Handbook, Form #600.**

6.12 Blade Guide Disc Adjustment

To ensure correct cutting, adjust the gap between the blade guide disc and the blade. Perform the adjustment with the blade installed and properly tensioned.

6

Sawmill Alignment

Blade Guide Disc Adjustment

See Figure 6-18. Loosen both nuts and retaining bolts. Use the adjustment bolt to raise or lower the disc until its distance from the blade is 0.3 - 0.5 mm. Then retighten the retaining bolts so that the disc is parallel to the blade. Retighten the retaining bolt nuts.

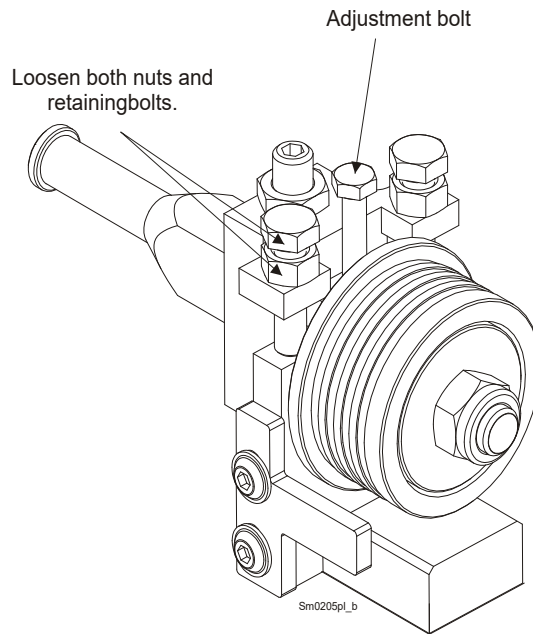

FIG. 6-18

See Figure 6-19. The gap between the disc and the blade should measure 0.3 - 0.5 mm.

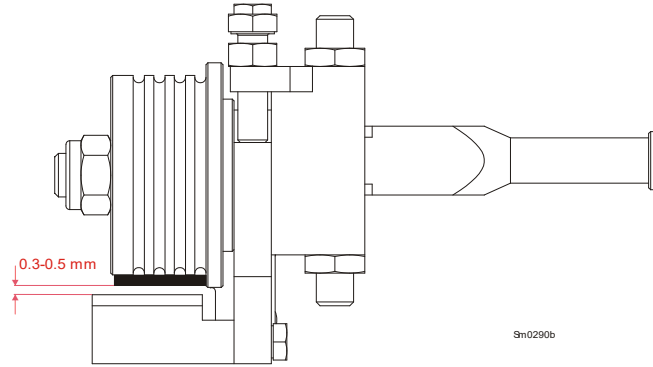

FIG. 6-19

6.13 Horizontal Adjustment of Side Supports

Logs and boards are clamped against the side supports when sawing. The sides supports must be square to the bed to ensure square lumber.

1. Swing the side support down.
2. Measure between the face of the support and the main bed tube. Make measurements at both ends of the side support to make sure that it is parallel to the rail.

See Figure 6-20.

3. Use the two lower bolts to adjust the side support so $B=A$.
4. Repeat for remaining side supports.

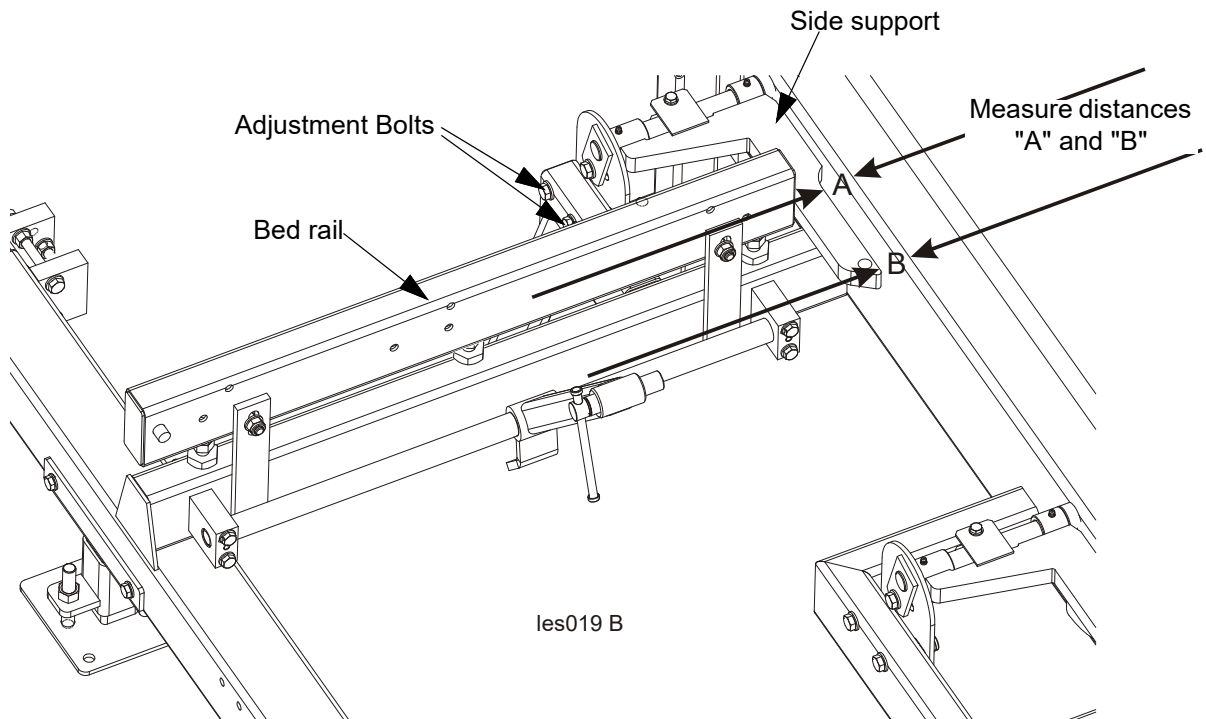

FIG. 6-20



Sawmill Alignment

Vertical Adjustment of Side Supports

6.14 Vertical Adjustment of Side Supports

1. Place a flat board across the bed rails.
2. Swing a side support up so that it is vertical.
3. Pull back at the top of the support to eliminate slack as if a log were being clamped against it.

See Figure 6-21.

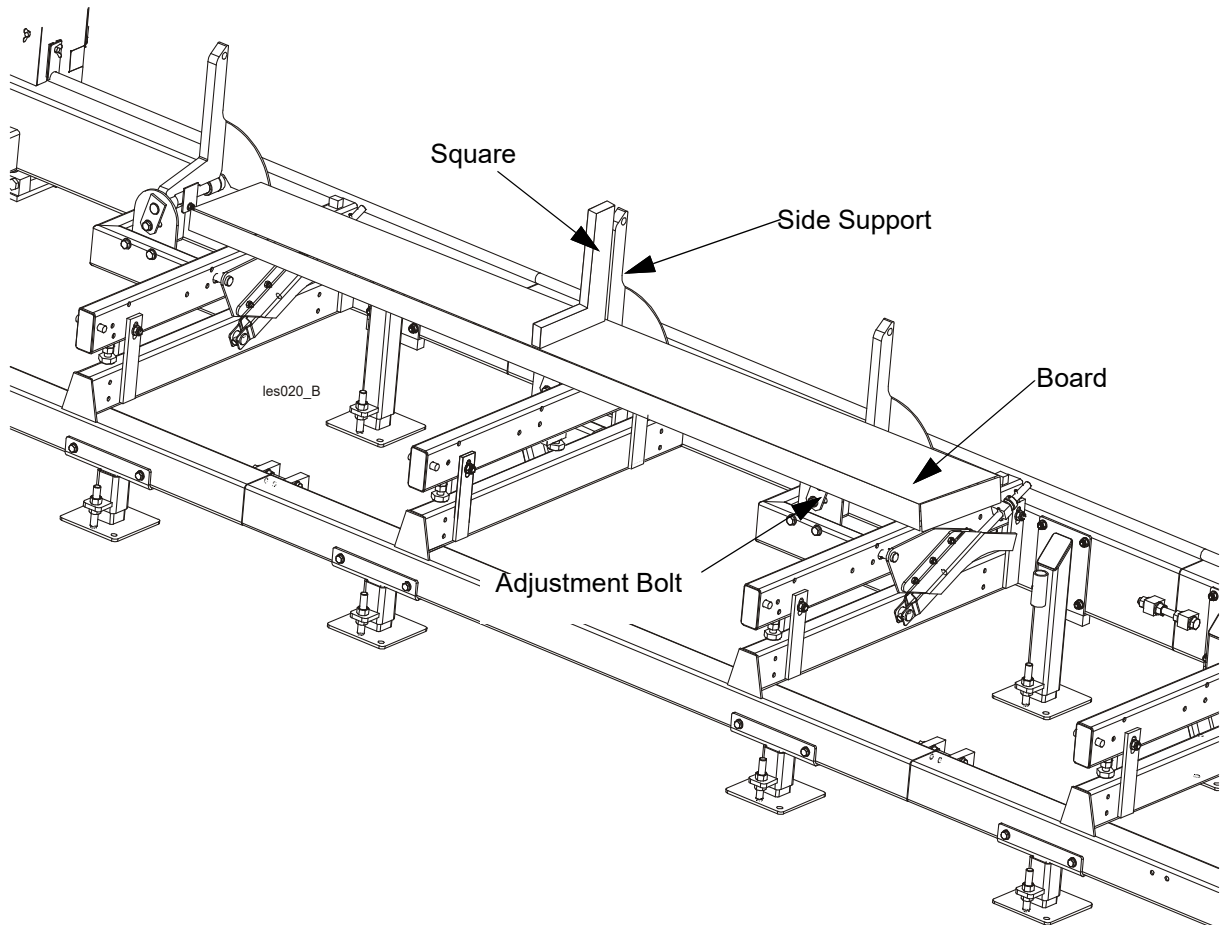

FIG. 6-21

4. Check the angle of each support with a square on the board.
5. The side support should be 90° to the bed rails. Loosen the top adjustment bolt, adjust the side support, and retighten the bolt.
6. Repeat for the remaining side supports.

6.15 Saw Head Tilt

As the blade enters a wide log or cant, the outside of the saw head will drop down slightly. To compensate for the drop, use the lower track roller horizontal bolts to raise the outside of the saw head 1/16" (1.5 mm).

6**Sawmill Alignment***Saw Head Tilt*

1. Move the saw head so the blade is positioned 14 3/4" (375 mm) above a bed rail.
2. Adjust the lower track roller horizontal nuts until the blade measures 14 13/16" (376 mm) from the bed rail near the outer blade guide.

See Figure 6-22.

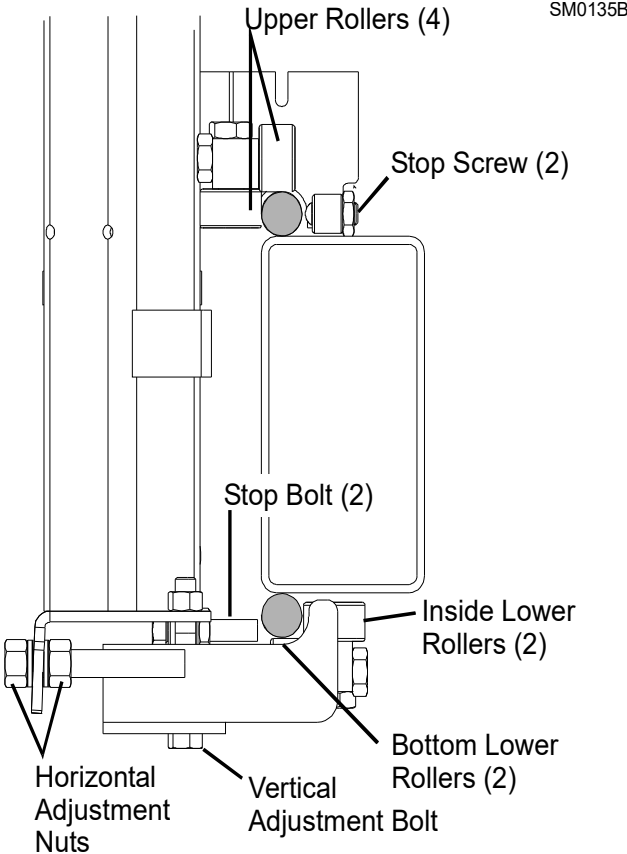

FIG. 6-22

6.16 Blade Height Scale Adjustment

After the entire sawmill has been aligned and all adjustments made, check that the blade height scale indicates the true distance from the blade to the bed rails.

1. Move the saw head so the blade is positioned directly above one of the bed rails. Measure from the bottom edge on a down-set tooth of the blade to the top of the bed rail (or stainless steel sleeve if applicable).

See Figure 6-23.

2. View the blade height scale with eyes level with the indicator.

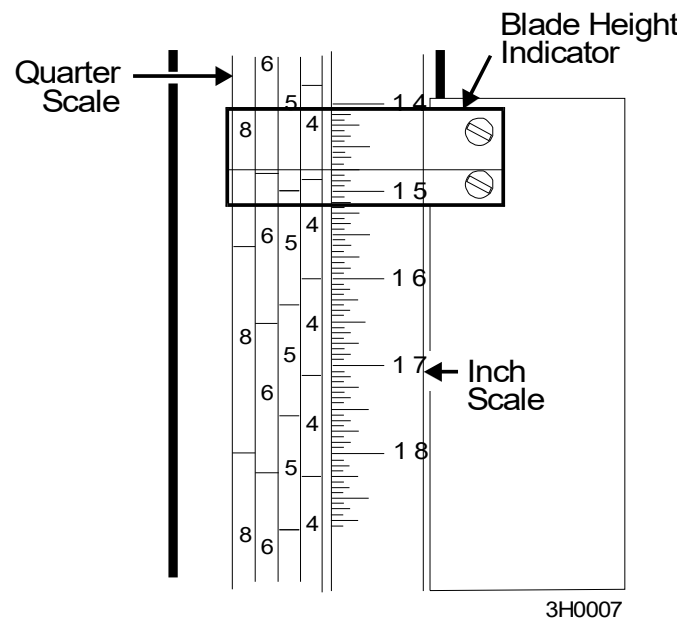

FIG. 6-23

3. Loosen the indicator bracket mounting bolts and adjust the bracket until the indicator is aligned with the correct mark on the scale. Re-tighten the bracket mounting nut.

For example, if the measurement from blade to bed rail was 14 3/4" (375 mm), make sure the indicator reads 14 3/4" (375 mm) on the scale.

EC declaration of conformity
according to EC Machinery Directive 2006/42/EC, Annex II, 1.A**Manufacturer:**Wood-Mizer Industries sp. z o.o.
Nagórna 114, 62-600 Koło; Poland
Tel. +48 63 26 26 000

This declaration of conformity is issued under the sole responsibility of the manufacturer.

Following machine in our delivered version complies with the appropriate essential safety and health requirements of the EC Machinery Directive 2006/42/EC based on its design and type, as brought into circulation by us. In case of alteration of the machine, not agreed by us, this declaration is no longer valid.

We, the undersigned herewith declare, that:Designation of the machine: Sawmill
Type: LT40
Serial Number:**Is in conformity with the following
EC directives:**EC Machinery Directive 2006/42/EC
EC Electromagnetic Compatibility Directive 2014/30/EU**And is in conformity with the following
Harmonized Standards:**PN-EN 1807-2: 2013-08
PN-EN ISO 13849-1:2016-02
PN-EN 60204-1:2018-12Notified Body according to annex IV : Sieć Badawcza Łukasiewicz
INSTYTUT TECHNOLOGII DREWNA
Centrum Certyfikacji Wyrobów Przemysłu Drzewnego
Winiarska 1, 60-654 Poznań

Notification No: 1583

EC type - examination certificate no: 0758/2020

Responsible for Technical Documentation: Piotr Adamiec / Engineering Manager
Wood-Mizer Industries Sp. z o.o.
62-600 Koło, ul. Nagórna 114, Poland
Tel. +48 63 26 26 000

Place / Date / Authorized Signature

Koło, 14.02.2020



Title:

Engineering Manager