

Wood-Mizer®

Replacement Parts

WM1000

rev. B2.00



Safety is our #1 concern! Read and understand all safety information and instructions before operating, setting up or maintaining this machine.

February 2011

Form #634

Table of Contents

Section-Page

SECTION 1	GENERAL INFORMATION	1-1
1.1	How To Use The Parts List	1-1
1.2	Sample Assembly	1-1
SECTION 2	WM1000 SAWMILL SAW HEAD	2-1
2.1	Drive Side Blade Wheel Assembly	2-1
2.2	Blade Drive Wheel Kits, 19 m/s, 22kW (Standard)	2-3
2.3	Blade Drive Wheel Kits, 17,6 m/s, 22kW (Optional)	2-4
2.4	Blade Drive Wheel Kits, 21,3 m/s, 22kW (Optional)	2-5
2.5	Blade Drive Wheel Kits, 19 m/s, 30kW (Standard)	2-6
2.6	Blade Drive Wheel Kits, 17,6 m/s, 30kW (Optional)	2-7
2.7	Blade Drive Wheel Kits, 21,3 m/s, 30kW (Optional)	2-8
2.8	Blade Drive Wheel Kits, 19 m/s, 37kW (Standard)	2-9
2.9	Blade Drive Wheel Kits, 17,6 m/s, 37kW (Optional)	2-10
2.10	Blade Drive Wheel Kits, 21,3 m/s, 37kW (Optional)	2-11
2.11	Drive Side Blade Wheel Scraper Assembly	2-12
2.12	Idle Side Blade Wheel Assembly	2-14
2.13	Idle Side Blade Wheel Scraper Assembly	2-16
2.14	Blade Guide Assembly	2-18
2.15	Blade Guide Drive Assembly	2-20
2.16	Blade Guide Tray	2-22
2.17	Motor Assembly, 22kW	2-24
2.18	Hydraulic Blade Tensioner Assembly	2-26
2.19	Oil Supply Assembly	2-28
2.20	Blade Wiper Assembly	2-30
2.21	Saw Head Covers	2-32
2.22	Blade Motor Cage Covers	2-34
2.23	Scale	2-35
2.24	Decals	2-37
SECTION 3	SAWMILL MAST	3-1
3.1	Track Roller Assembly	3-1
3.2	Power Feed Assembly	3-3
3.3	Saw Head Support Rollers	3-5
3.4	Up/Down Drive	3-6
3.5	Operator Platform	3-8
3.6	Power Cord Bracket	3-9
3.7	Electrical Wires Covers	3-10
3.8	Mast Limit Switch	3-12
3.9	6 m & 15 m Tracks	3-13
3.10	Tracks: 10 m & 10 m Extension	3-15
3.11	33' & 66' Track Assembly (U.S. Only)	3-17
SECTION 4	CONTROL BOX	4-1
4.1	Control Box Assembly	4-1
4.2	Control Box Bracket	4-3

Table of Contents

Section-Page

4.3 Switches.....4-4
4.4 Circuit Breakers4-5

SECTION 1 GENERAL INFORMATION

1.1 How To Use The Parts List

- Use the index above to locate the assembly that contains the part you need.
- Go to the appropriate section and locate the part in the illustration.
- Use the number pointing to the part to locate the correct part number and description in the table.
- Parts shown indented under another part are included with that part.
- Parts marked with a diamond (◆) are only available in the assembly listed above the part.

See the sample table below. Sample Part #A01111 includes part F02222-2 and subassembly A03333. Subassembly A03333 includes part S04444-4 and subassembly K05555. The diamond (◆) indicates that S04444-4 is not available except in subassembly A03333. Subassembly K05555 includes parts M06666 and F07777-77. The diamond (◆) indicates M06666 is not available except in subassembly K05555.

1.2 Sample Assembly				
REF	DESCRIPTION (◆ Indicates Parts Available In Assemblies Only)	PART #	QTY.	
	Sample Assembly, Complete (Includes All Indented Parts Below)	A01111	1	
1	Sample Part	F02222-22	1	
	Sample Subassembly (Includes All Indented Parts Below)	A03333	1	
2	Sample Part (◆ Indicates Part Is Only Available With A03333)	S04444-4	1	◆
	Sample Subassembly (Includes All Indented Parts Below)	K05555	1	
3	Sample Part (◆ Indicates Part Is Only Available With K05555)	M06666	2	◆
4	Sample Part	F07777-77	1	

To Order Parts:

- From Europe call our European Headquarters and Manufacturing Facility in Kolo, Poland at **+48-63-2626000**. From the continental U.S., call our toll-free Parts hotline at **1-800-525-8100**. Have your customer number, vehicle identification number, and part numbers ready when you call. From other international locations, contact the Wood-Mizer distributor in your area for parts.

Office Hours:

Country	Monday - Friday	Saturday	Sunday
Poland	7-15	Closed	Closed
US	8 a.m.- 5 p.m.	Closed	Closed



CAUTION! It is strongly recommended that only original spare parts be used.

SECTION 2 WM1000 SAWMILL SAW HEAD

2.1 Drive Side Blade Wheel Assembly

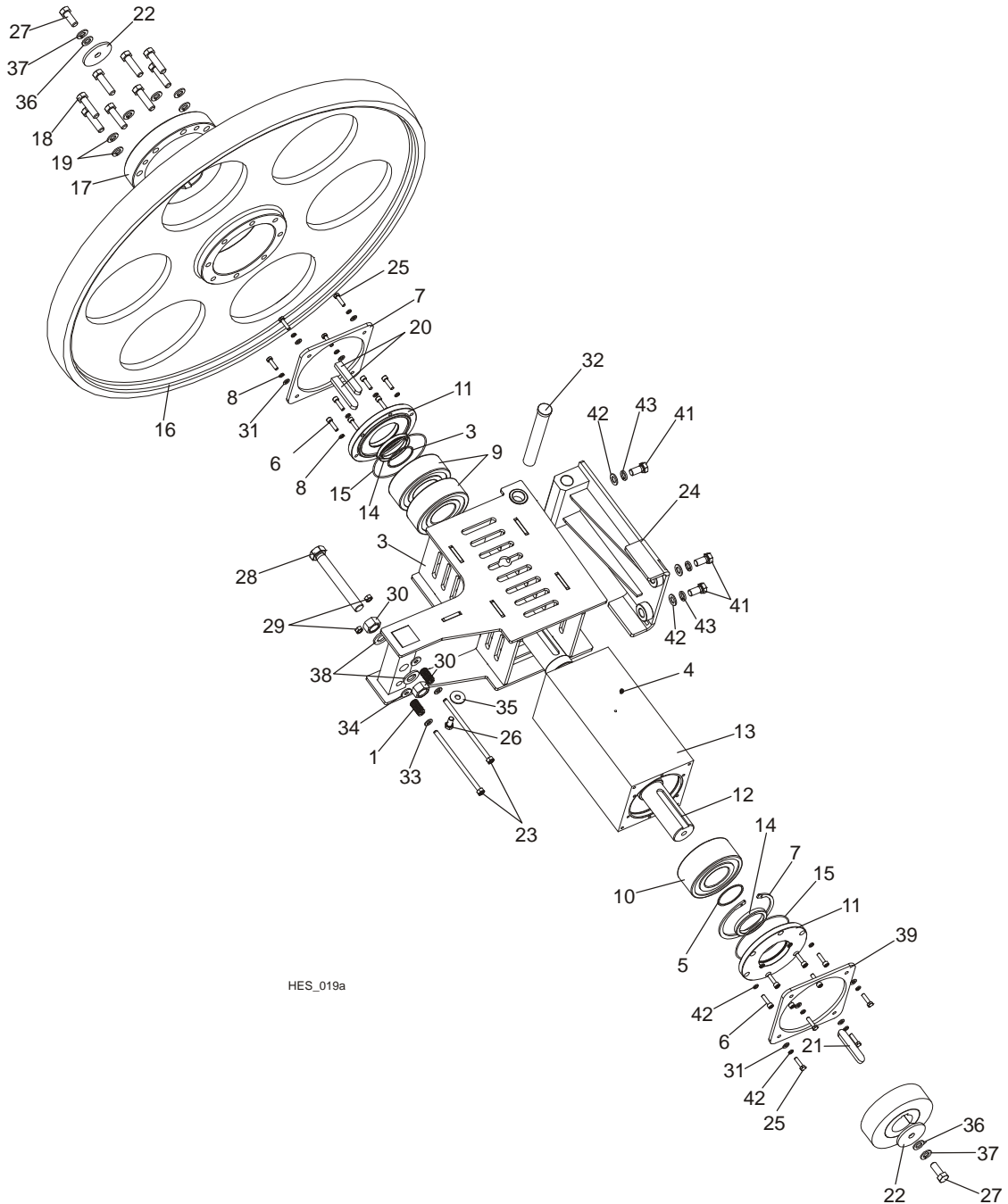

REF.	DESCRIPTION (◆ Indicates Parts Available In Assemblies Only)	PART #	QTY.
	DRIVE SIDE BLADE WHEEL ASSEMBLY	503935	1
1	SPRING, 19X38 COMPRESSION	034430	2
2	SHEAVE, 3SPB ULMER F02397+T31169	500327	1
3	BRACKET, WM1000 DRIVE SHAFT ASSEMBLY	501387-1	1

	DRIVE SHAFT ASSEMBLY	507912		
4	FITTING, M6 TYPE A GREASE	086280	1	
5	RING, Z70 SPRING RETAINING	089165	1	
6	BOLT, M8X30 -8.8- SOCKET HEAD	F81002-31	12	
7	RING, W150SPRING RETAINING	F81090-43	1	
8	WASHER, 8,2 SPLIT LOCK ZINC	F81054-4	12	
9	BEARING, NJ2314E.TVP2-WM1000	503932	2	
10	BEARING, 22314 E-WM1000 BARREL	509478	1	
11	PLATE, GASKET RING MOUNTING - ZINC	503934-1	2	
12	SHAFT, DRIVE WM1000	503937	1	
13	HOUSING, DRIVE SHAFT WM1000	503938-1	1	
14	RING, CC70X90X10-WM1000 GASKET	503943	2	
15	O-RING OR150X3 NBR-WM1000	503944	2	
	DRIVE SIDE BLADE WHEEL ASSEMBLY WM1000	504153-1	1	
16	WHEEL, 42" DRIVE SIDE BLADE WHEEL	503945-1	1	
17	BUSHING, DRIVE SIDE WHEEL	504152	1	
18	BOLT, M16x60 8.8 HEX HEAD FULL THREAD ZINC	F81006-12	8	
19	WASHER, 16,3 SPLITLOCK ZINC	F81058-2	8	
20	KEY, AB 18X11X100 PARALLEL	504602	2	
21	KEY, AB 18X11X125 PARALLEL	504603	1	
22	WASHER, ϕ 16.5x ϕ 80x6 special	504604-1	2	
23	BOLT, M10X200	504713	2	
24	BRACKET, WM1000 DRIVE WHEEL PIVOT	501390-1	1	
25	BOLT, M8X30-8.8-B-HEX HEAD FULL THREAD ZINC	F81002-7	8	
26	BOLT, M12X25-8.8-HEX HEAD FULL THREAD ZINC	F81004-31	1	
27	BOLT, M16X40-8.8 HEX HEAD FULL THREAD ZINC	F81006-13	2	
28	BOLT, 4017-M24X180 HEX HEAD	F81009-9	1	
29	NUT, M10-8-B-HEX ZINC	F81033-3	2	
30	NUT, M24-8-B-HEX ZINC	F81039-12	2	
31	WASHER, 8,4-FLAT ZINC	F81054-1	8	
32	PIN, MAIN SHAFT HOUSING	502971-1	1	
33	WASHER, 10,5 FLAT ZINC	F81055-1	2	
34	WASHER, 10,5 SPECIAL FLAT ZINC	F81055-6	2	
35	WASHER, 13 SPECIAL FLAT ZINC	F81056-14	1	
36	WASHER, 17 FLAT ZINC	F81058-1	2	
37	WASHER, 16,3 SPLIT LOCK ZINC	F81058-2	2	
38	WASHER, 25 FLAT ZINC	F81061-3	2	
39	PLATE, WM1000 MAIN SHAFT COVER REST	501749-1	2	
40	WASHER, 8,2 SPLIT LOCK ZINC	F81054-4	8	
41	BOLT, M24X50 8.8 HEX HEAD FULL THREAD ZINC	F81009-13	3	
42	WASHER, 25 FLAT ZINC	F81061-3	3	
43	WASHER, Z24,5 SPLIT LOCK ZINC	F81061-4	3	

2.2 Blade Drive Wheel Kits, 19 m/s, 22kW (Standard)

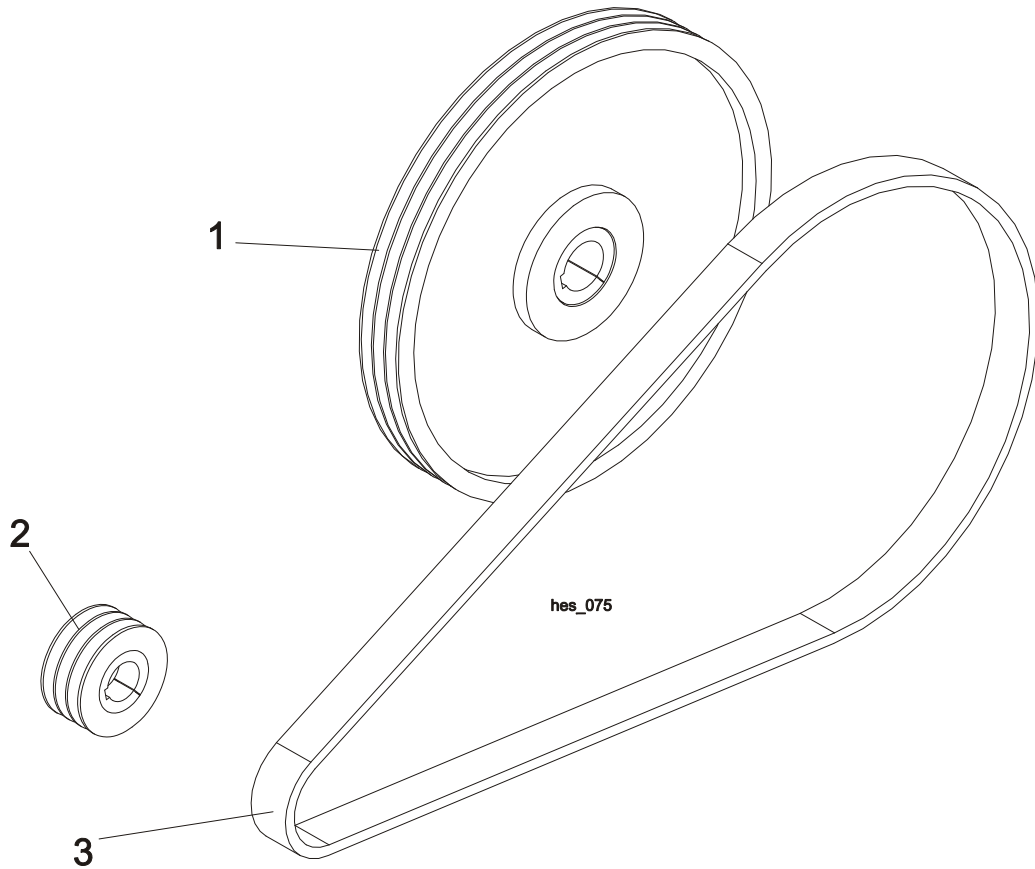

REF.	DESCRIPTION (◆ Indicates Parts Available In Assemblies Only)	PART #	QTY.	
	KIT, DRIVE WHEEL WM1000 19M/S 22KW	507929	1	
1	PULLEY, ULMER SPB-3 F01906+T31169	508283	1	
2	PULLEY SPB-3 D125 TAPER-LOCK 2012/48	500326	1	
3	BELT, OPTIBELT 3HB 2750	508284	1	

2 WM1000 SAWMILL SAW HEAD

Blade Drive Wheel Kits, 17,6 m/s, 22kW (Optional)

2.3 Blade Drive Wheel Kits, 17,6 m/s, 22kW (Optional)

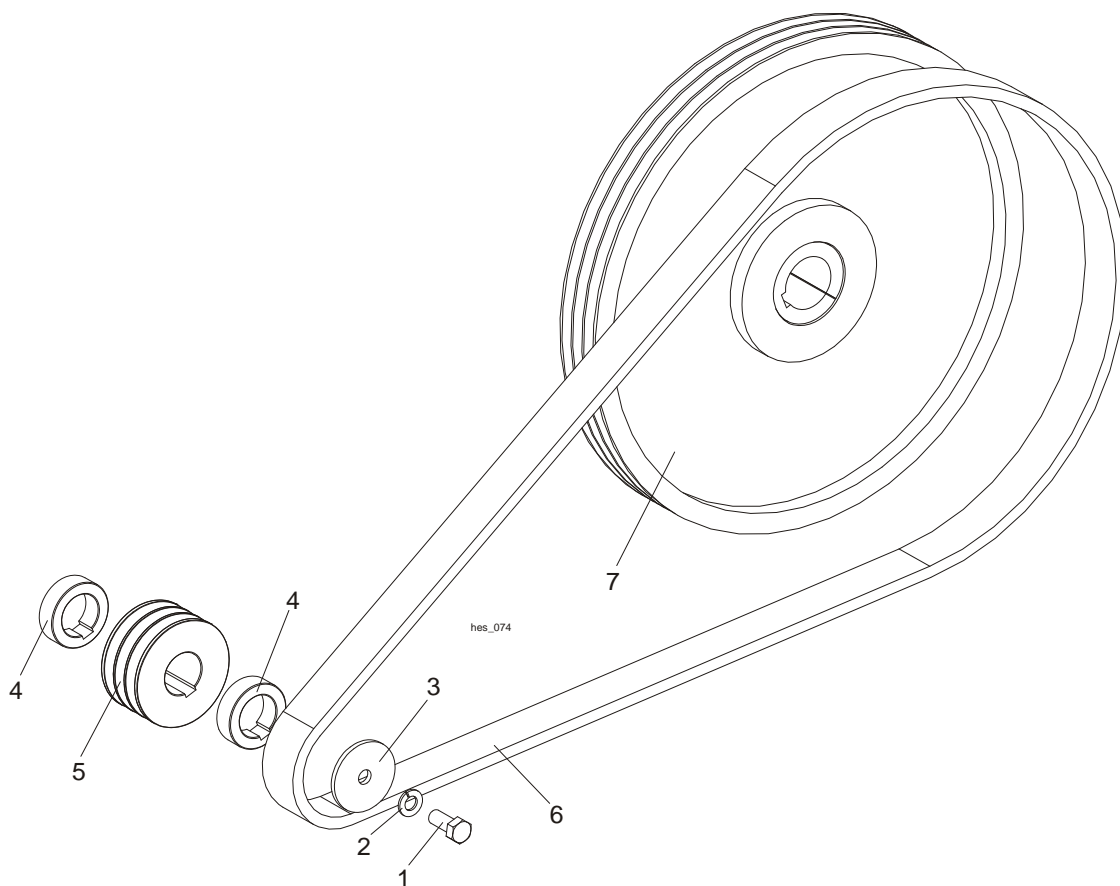

REF.	DESCRIPTION (◆ Indicates Parts Available In Assemblies Only)	PART #	QTY.
	KIT, DRIVE WHEEL WM1000 17.6M/S 22KW	507928	1
1	BOLT,M16X40-8.8 HEX HEAD FULL THREAD ZINC	F81006-13	1
2	WASHER,16.3 SPLIT LOCK ZINC	F81058-2	1
3	WASHER, SPECIAL FI16.5FI80X6 WM1000-ZINC	504604-1	1
4	SPACER SPECIAL 75X48X24	507937-1	2
5	PULLEY 3B 122X48	507927-1	1
6	DRIVE BELT OPTIBELT 3HB 2750	508284	1
7	SHEAVE ULMER SPB-3 F01906+T31169	508283	1

2.4 Blade Drive Wheel Kits, 21,3 m/s, 22kW (Optional)

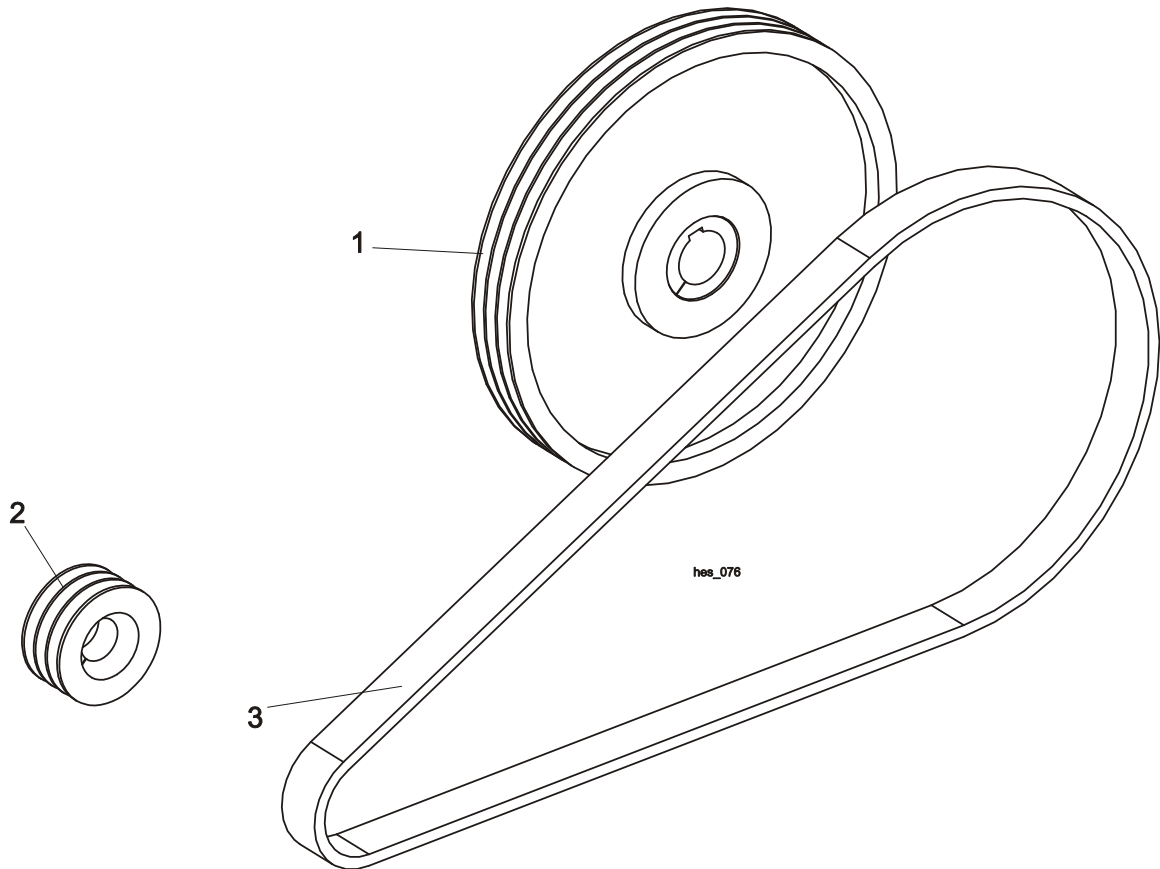

REF.	DESCRIPTION (◆ Indicates Parts Available In Assemblies Only)	PART #	QTY.	
	KIT, DRIVE WHEEL WM1000 21,3M/S 22KW	507930	1	
1	PULLEY, ULMER 3SPB ULMER F02397+T31169	500327	1	
2	PULLEY SPB-3 D125 TAPER-LOCK 2012/48	500326	1	
3	BELT, .3B BP LE 2640	504790	1	

2 **WM1000 SAWMILL SAW HEAD**
Blade Drive Wheel Kits, 19 m/s, 30kW (Standard)

2.5 Blade Drive Wheel Kits, 19 m/s, 30kW (Standard)

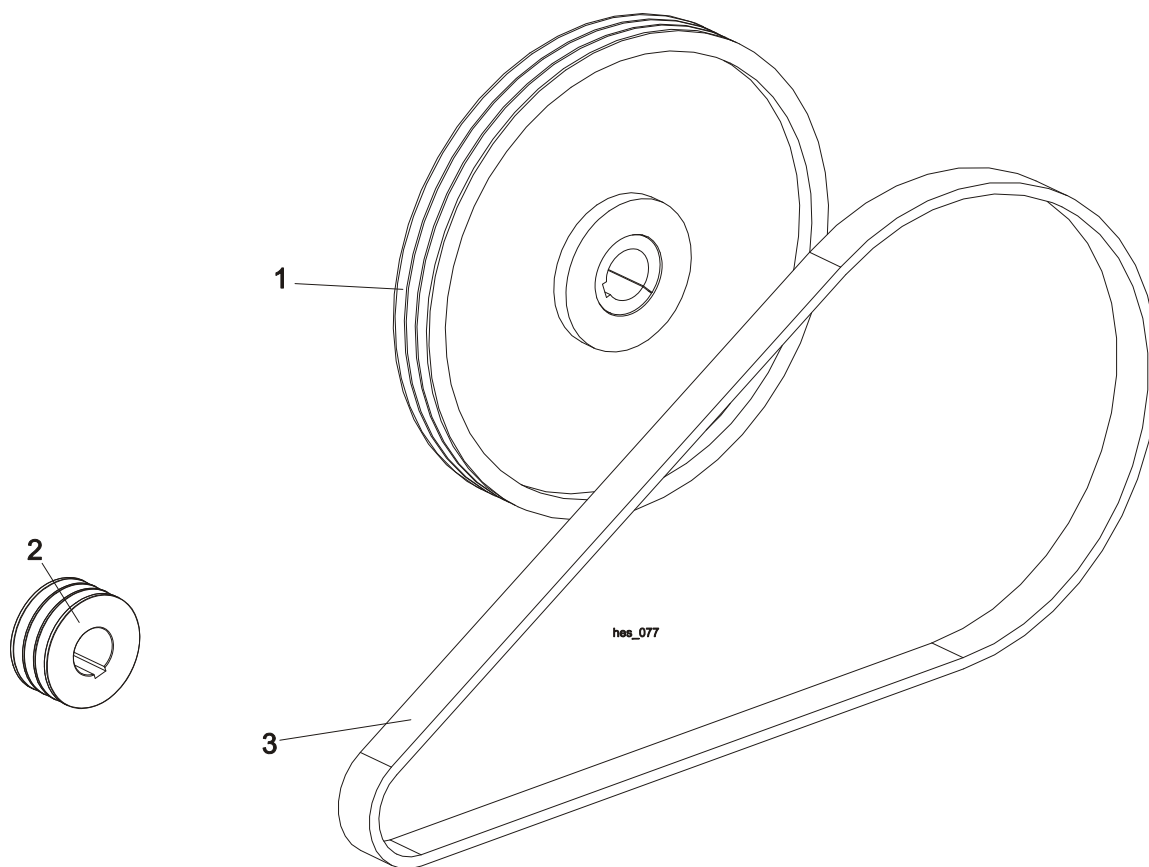

REF.	DESCRIPTION (◆ Indicates Parts Available In Assemblies Only)	PART #	QTY.	
	KIT, DRIVE WHEEL WM1000 19M/S 30KW	507932	1	
1	PULLEY, ULMER SPB-3 F01906+T31169	508283	1	
2	PULLEY 3B DIAMETER.132X55	505498-1	1	
3	BELT, ULMER SPB-3 F01906+T31169	508283	1	

2.6 Blade Drive Wheel Kits, 17,6 m/s, 30kW (Optional)

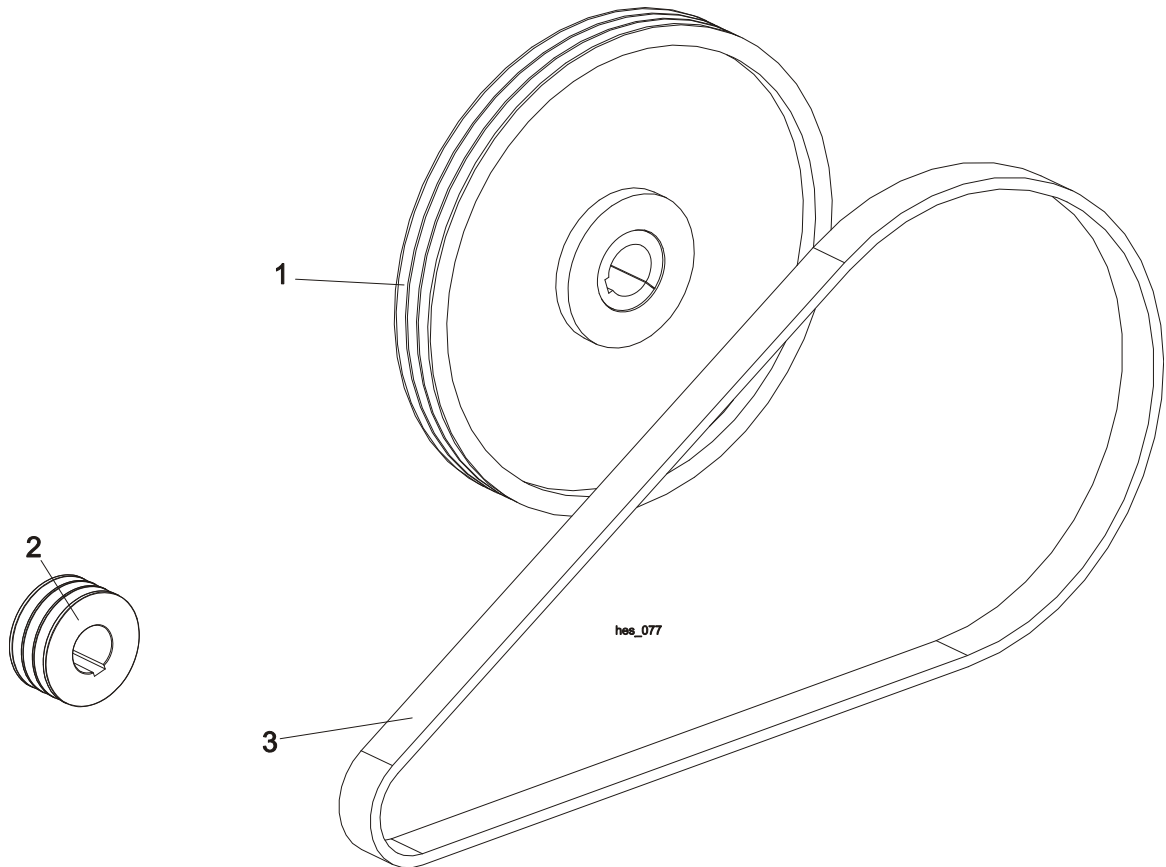

REF.	DESCRIPTION (◆ Indicates Parts Available In Assemblies Only)	PART #	QTY.	
	KIT, DRIVE WHEEL WM1000 17,6 M/S 30KW	507931	1	
1	PULLEY, ULMER SPB-3 F01906+T31169	508283	1	
2	PULLEY 3B DIAMETER.122X55	507926-1	1	
3	BELT, OPTIBELT 3HB 2750	508284	1	

2 **WM1000 SAWMILL SAW HEAD**
Blade Drive Wheel Kits, 21,3 m/s, 30kW (Optional)

2.7 Blade Drive Wheel Kits, 21,3 m/s, 30kW (Optional)

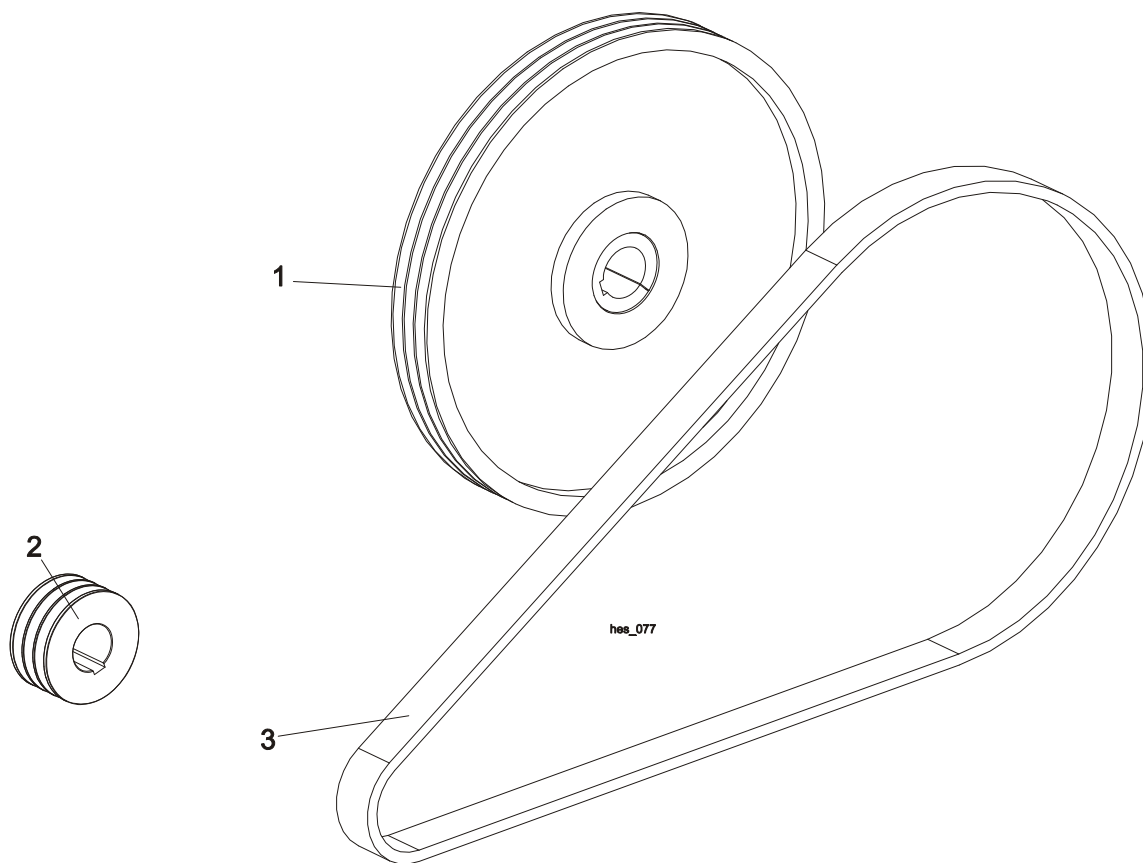

REF.	DESCRIPTION (◆ Indicates Parts Available In Assemblies Only)	PART #	QTY.	
	KIT, DRIVE WHEEL WM1000 21,3 M/S 30KW	507933	1	
1	PULLEY, 3SPB ULMER F02397+T31169	500327	1	
2	PULLEY 3B DIAMETER.132X55	505498-1	1	
3	BELT, 3B BP LE 2640	504790	1	

2.8 Blade Drive Wheel Kits, 19 m/s, 37kW (Standard)

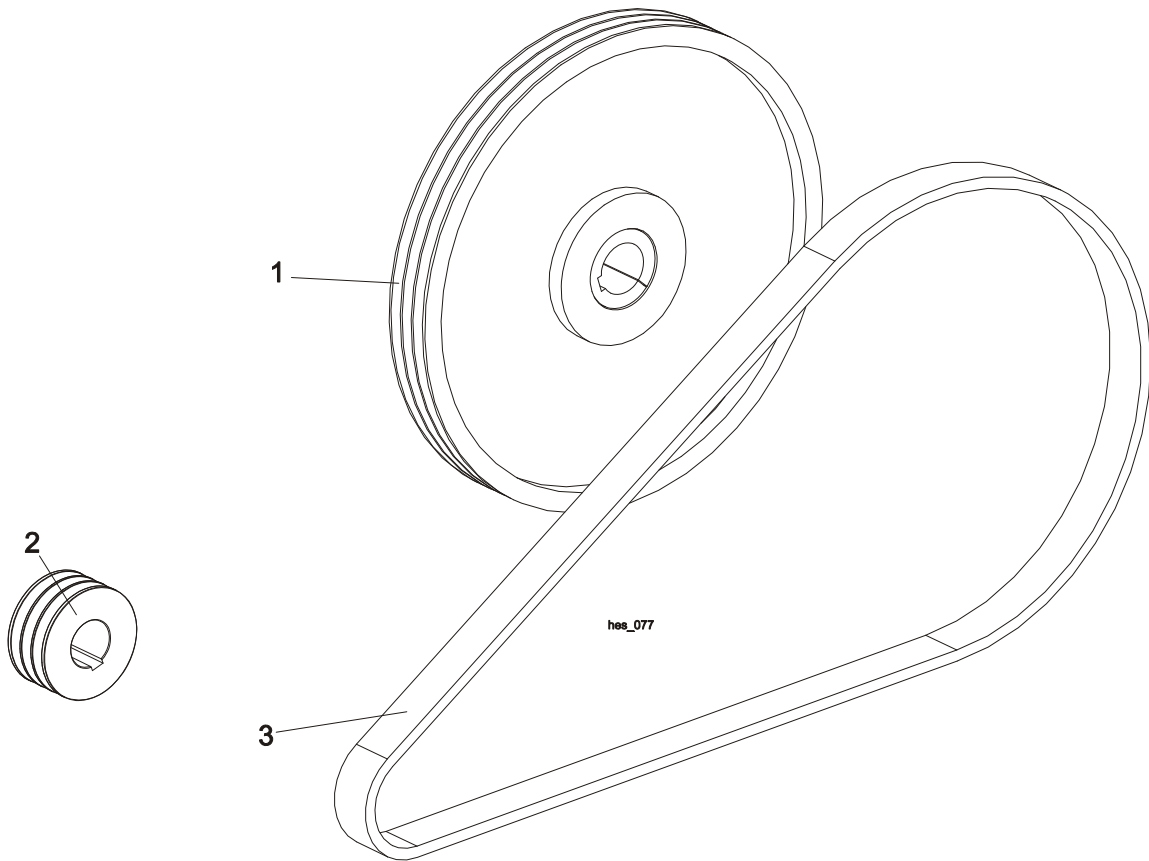

REF.	DESCRIPTION (◆ Indicates Parts Available In Assemblies Only)	PART #	QTY.	
	KIT, DRIVE WHEEL WM1000 19M/S 30KW	507935	1	
1	PULLEY, ULMER SPB-3 F01906+T31169	508283	1	
2	PULLEY ULMER SPB-3 F01906+T31169	505499-1	1	
3	BELT, OPTIBELT 3HB 2750	508284	1	

2 **WM1000 SAWMILL SAW HEAD**
Blade Drive Wheel Kits, 17,6 m/s, 37kW (Optional)

2.9 Blade Drive Wheel Kits, 17,6 m/s, 37kW (Optional)

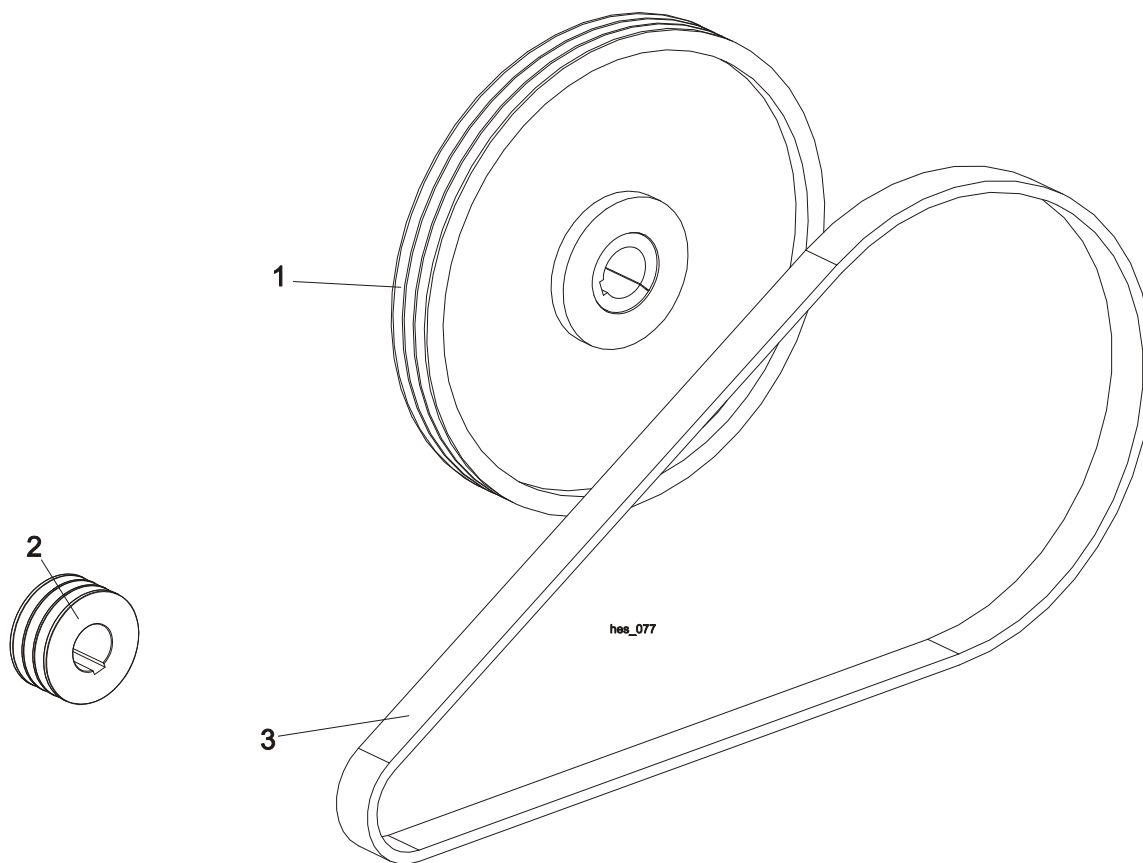

REF.	DESCRIPTION (◆ Indicates Parts Available In Assemblies Only)	PART #	QTY.	
	KIT, DRIVE WHEEL WM1000 17,6 M/S 30KW	507934	1	
1	PULLEY, ULMER SPB-3 F01906+T31169	508283	1	
2	PULLEY 3B DIAMETER.122X60	508282-1	1	
3	BELT, OPTIBELT 3HB 2750	508284	1	

2.10 Blade Drive Wheel Kits, 21,3 m/s, 37kW (Optional)

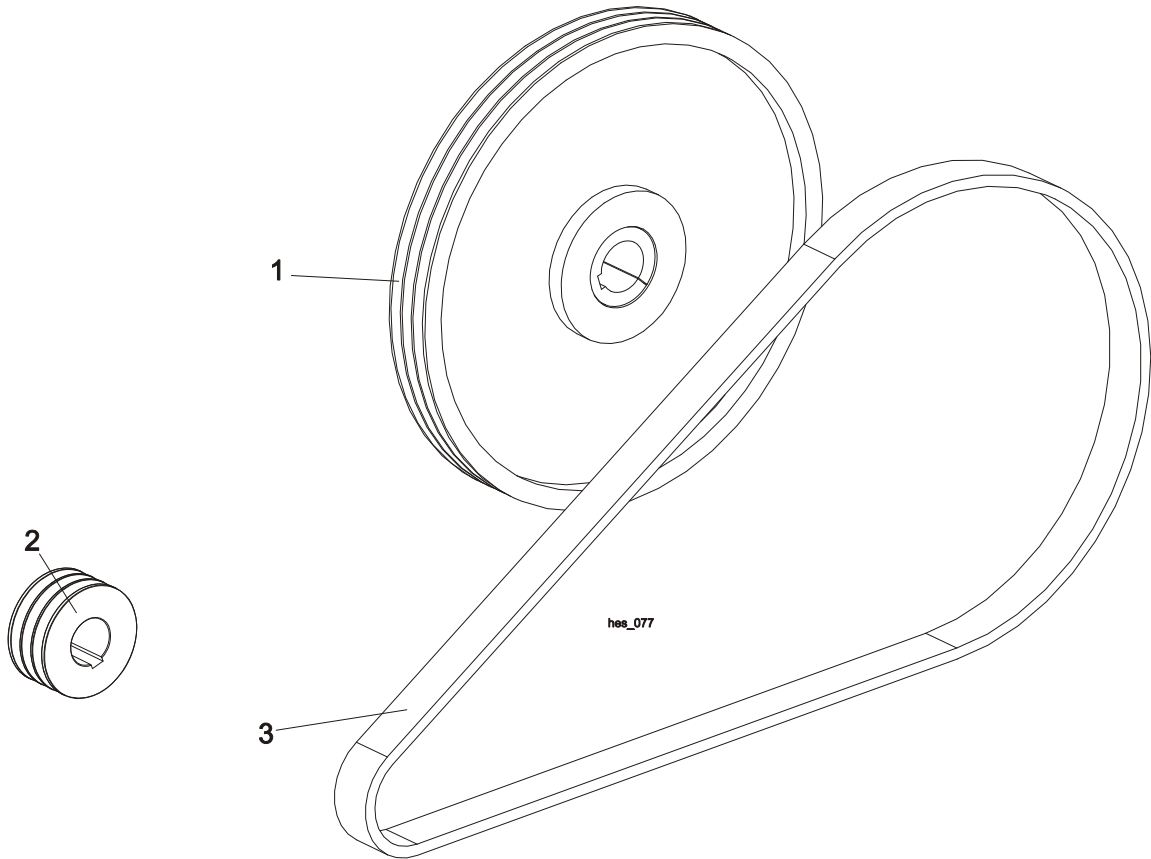

REF.	DESCRIPTION (◆ Indicates Parts Available In Assemblies Only)	PART #	QTY.	
	KIT, DRIVE WHEEL WM1000 21,3 M/S 30KW	507936	1	
1	PULLEY, 3SPB ULMER F02397+T31169	500327	1	
2	PULLEY 3B DIAMETER.132X560	505499-1	1	
3	BELT, 3B BP LE 2640	504790	1	

2.11 Drive Side Blade Wheel Scraper Assembly

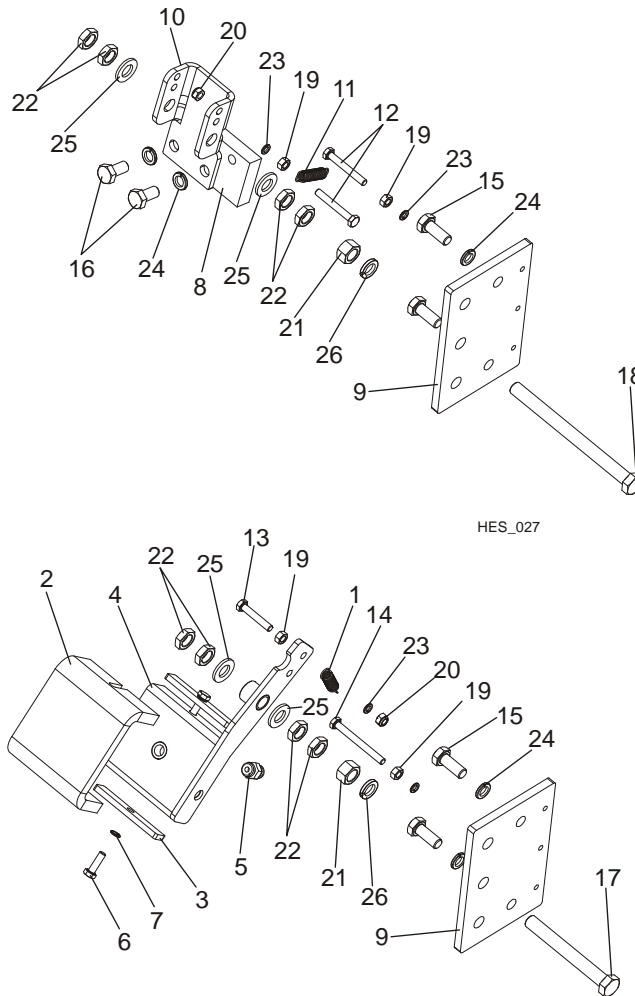

REF.	DESCRIPTION (◆ Indicates Parts Available In Assemblies Only)	PART #	QTY.	
	DRIVE SIDE BLADE WHEEL SCRAPER ASSEMBLY	504711	1	
1	SPRING, 1,6X12X38 EXTENSION	092208	1	
	BLADE WIPER ASSEMBLY, UPPER	500986	1	
2	PAD, OILER FELT	500808	1	
3	FLAT BAR, FELT MOUNT ZINC	500813-1	2	
4	ARM, FELT MOUNT RIGHT	500832-1	1	
5	FITTING, 6MM (KAH06-U02) ONE-TOUCH	503977	1	
6	BOLT, M6x20-8.8-HEX HEAD FULL THREAD ZINC	F81001-2	2	
7	WASHER, Z 6,1 SPLIT LOCK ZINC	F81053-3	2	
8	SCRAPER	501922	1	
9	PLATE, SCRAPER MOUNTING ZINC	502668-1	2	
10	PLATE, SCRAPER MOUNTING ZINC	503260-1	1	
11	SPRING, 1X10X30-ZINC WM1000 EXTENSION	504701-1	1	
12	BOLT, M6X45-8.8-HEX HEAD ZINC	F81001-6	2	

WM1000 SAWMILL SAW HEAD
Drive Side Blade Wheel Scraper Assembly

2

13	BOLT, M6X35 8.8 HEX HEAD ZINC	F81001-71	1	
14	BOLT, M6X60-8.8-HEX HEAD FULL THREAD ZINC	F81001-9	1	
15	BOLT, M10X25-8.8-HEX HEAD FULL THREAD ZINC	F81003-11	4	
16	BOLT, ISO4017-M10X20-8.8-A2E HEX HEAD	F81003-53	2	
17	BOLT, M12X100 8.8 HEX HEAD FULL THREAD ZINC	F81004-45	1	
18	BOLT, M12X150-8.8-HEX HEAD FULL THREAD ZINC	F81004-54	1	
19	NUT, M6-8-HEX ZINC	F81031-1	4	
20	BOLT, M6-8-B-HEX NYLON ZINC LOCK	F81031-2	2	
21	NUT, M12-8-B HEX ZINC	F81034-1	2	
22	NUT, M12 THIN ZINC	F81034-6	8	
23	WASHER, Z 6,1 SPLIT LOCK ZINC	F81053-3	4	
24	WASHER, 10.2 SPLIT LOCK ZINC	F81055-2	6	
25	WASHER, 13 FLAT ZINC	F81056-1	4	
26	WASHER, Z12,2 SPLIT LOCK ZINC	F81056-2	2	

2.12 Idle Side Blade Wheel Assembly

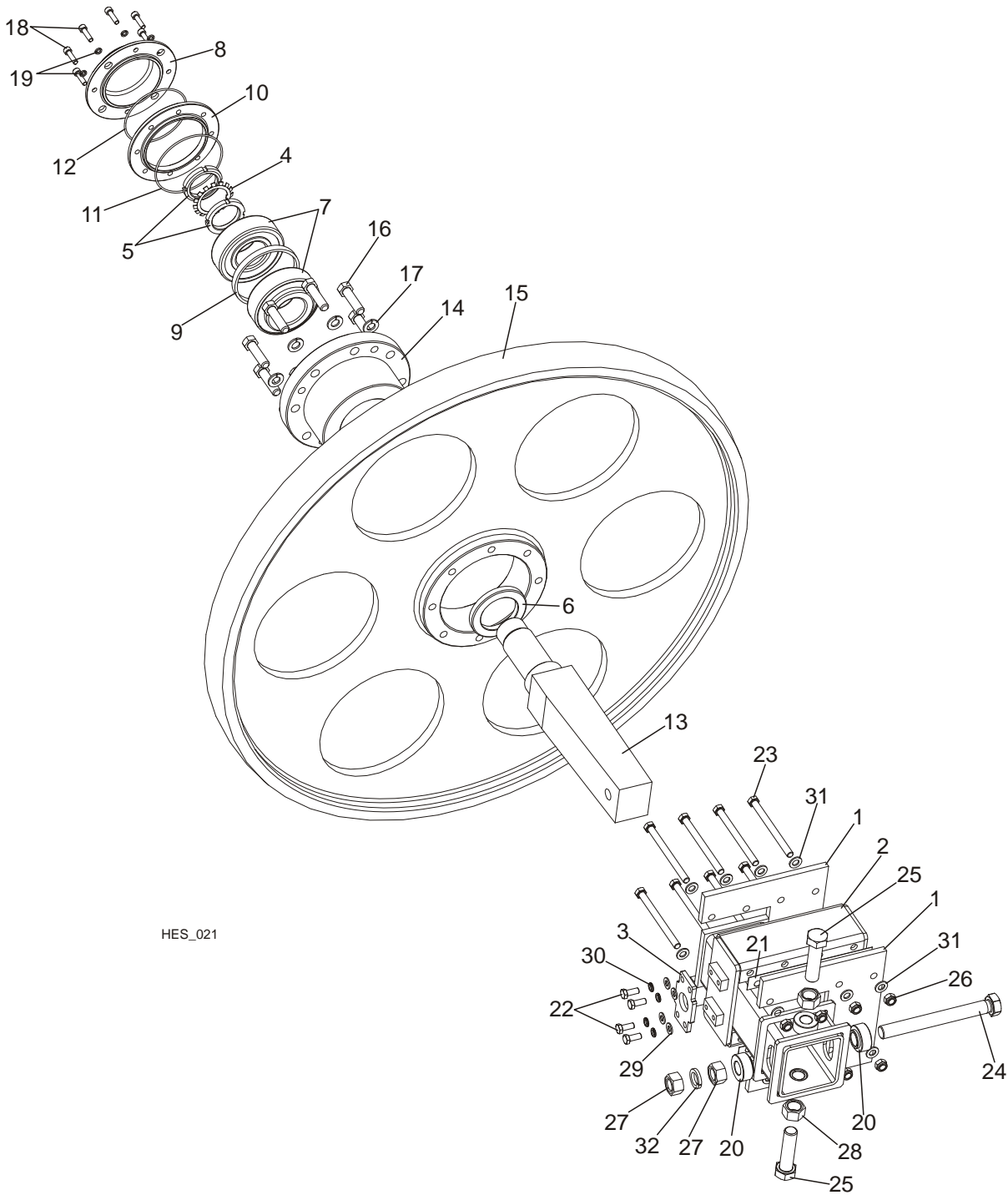

HES_021

REF.	DESCRIPTION (◆ Indicates Parts Available In Assemblies Only)	PART #	QTY.
	IDDL SIDE BLADE WHEEL ASSEMBLY	501385	1
1	PLATE, WM1000 ROCKER ARM VERTICAL PTD	501537-1	2
2	HOUSING, WELDMENT IDLER SHAFT - WM1000 COMPLETE	501539-1	1
3	PLATE, WM1000 BLADE TENSIONER CYLINDER	501542-1	1

	IDLE BLADE WHEEL ASSEMBLY WM1000	503940	1	
4	WASHER, MB11-WM1000 LOCK	501351	1	
5	NUT, KM11-WM1000 LOCK	501352	2	
6	RING, CC75x110x12-WM1000 CONNECTOR SEAL	501353	1	
7	BEARING, 32312A -WM1000	501373	2	
8	CAP, WM1000 BEARING	501384-1	1	
9	SPACER, $\phi 120 \times \phi 129.8 \times 12$	501844	1	
10	RING, WM1000 BEARING RETAINING	502775-1	1	
11	O-RING OR130x3 NBR-WM1000	502952	1	
12	O-RING OR120x3 NBR-WM1000	503941	1	
13	SHAFT, IDLER WHEEL WM1000	503942	1	
	IDLE SIDE BLADE WHEEL ASSEMBLY WM1000	504154-1	1	
14	SLEEVE, IDLER WHEEL BEARING	503936	1	
15	WHEEL, 42" BLADE	503945-1	1	
16	BOLT, M16x60 8.8 HEX HEAD FULL THREAD ZINC	F81006-12	8	
17	WASHER, 16,3 SPLIT LOCK ZINC	F81058-2	8	
18	BOLT, M8x30 -8.8- SOCKET HEAD ZINC	F81002-31	8	
19	WASHER, 8,2 SPLIT LOCK ZINC	F81054-4	8	
20	BUSHING, SHAFT HOUSING	504156-1	2	
21	PAD, WM1000 ROCKER ARM	504703	1	
22	BOLT, M10X25-8.8-HEX HEAD FULL THREAD ZINC	F81003-11	4	
23	BOLT, M12X150-8.8-HEX HEAD FULL THREAD ZINC	F81004-54	8	
24	BOLT, ISO8676-M24X2X220-8 HEX HEAD	F81009-7	1	
25	BOLT, 4017-M24X90-8 HEX HEAD FULL THREAD	F81009-8	2	
26	NUT, M12-8 HEX NYLON ZINC LOCK	F81034-2	8	
27	NUT, M24X2-8-B-HEX ZINC	F81039-11	2	
28	NUT, M24-8-B HEX ZINC	F81039-12	2	
29	WASHER, 10,5 FLAT ZINC	F81055-1	4	
30	WASHER, 10,2 SPLIT LOCK ZINC	F81055-2	4	
31	WASHER, 13 FLAT ZINC	F81056-1	16	
32	WASHER, Z24,5 SPLIT LOCK ZINC	F81061-4	1	

2.13 Idle Side Blade Wheel Scraper Assembly

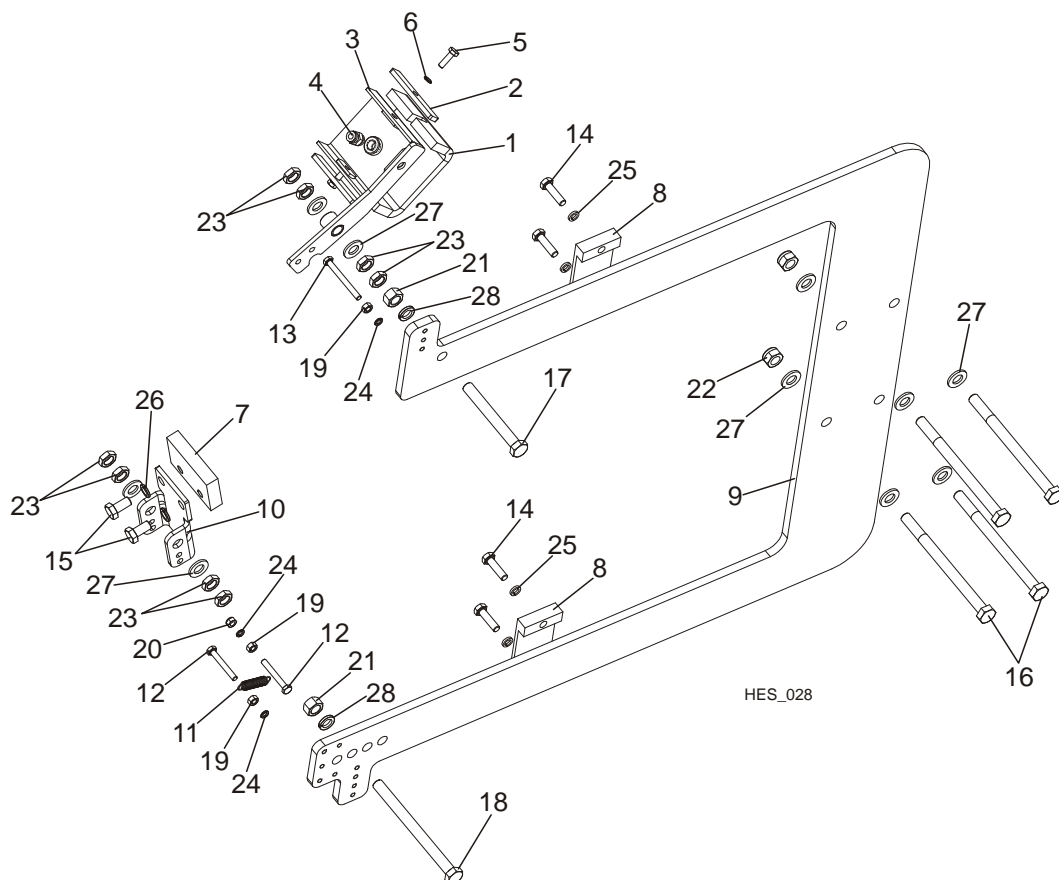

REF.	DESCRIPTION (◆ Indicates Parts Available in Assemblies Only)	PART #	QTY.
	IDLE SIDE BLADE WHEEL SCRAPER ASSEMBLY	502121	1
	BLADE SCRAPER ASSEMBLY, UPPER	500986	1
1	PAD, FELT	500808	1
2	FLAT BAR, FELT MOUNT ZINC	500813-1	2
3	ARM, FELT MOUNT RIGHT	500832-1	1
4	FITTING, 6MM (KAH06-U02) ONE-TOUCH	503977	1
5	BOLT, M6x20-8.8-HEX HEAD FULL THREAD ZINC	F81001-2	2
6	WASHER, Z 6,1 SPLIT LOCK ZINC	F81053-3	2
7	SCRAPER	501922	1
8	BLOCK, GUIDE MOUNTING ZINC	502116-1	2
9	PLATE, ROCKER ARM VERTICAL ZINC	502118-1	1
10	PLATE, SCRAPER MOUNTING ZINC	503260-1	1
11	SPRING, 1X10X30- WM1000 EXTENSION ZINC	504701-1	1
12	BOLT, M6X45-8.8-HEX HEAD ZINC	F81001-6	2
13	BOLT, M6X60-8.8-HEX HEAD FULL THREAD ZINC	F81001-9	1
14	BOLT, M8X30-8.8-B-HEX HEAD FULL THREAD ZINC	F81002-7	4
15	BOLT, ISO4017-M10X20-8.8-A2E HEX HEAD	F81003-53	2

WM1000 SAWMILL SAW HEAD*Idle Side Blade Wheel Scraper Assembly***2**

16	BOLT, M12X160-8.8-HEX HEAD ZINC	F81004-13	4	
17	BOLT, M12X100 8.8 HEX HEAD FULL THREAD ZINC	F81004-45	1	
18	BOLT, M12X150-8.8-HEX HEAD FULL THREAD ZINC	F81004-54	1	
19	NUT, M6-8-HEX ZINC	F81031-1	3	
20	NUT, M6-8-B-HEX NYLON ZINC LOCK	F81031-2	1	
21	NUT, M12-8-B HEX ZINC	F81034-1	2	
22	NUT, M12-8 HEX NYLON ZINC LOCK	F81034-2	4	
23	NUT, M12THIN ZINC	F81034-6	8	
24	WASHER, Z 6,1 SPLIT LOCK ZINC	F81053-3	3	
25	WASHER, 8,2 SPLIT LOCK ZINC	F81054-4	4	
26	WASHER, 10.2 SPLIT LOCK ZINC	F81055-2	2	
27	WASHER, 13 FLAT ZINC	F81056-1	12	
28	WASHER, Z12,2 SPLIT LOCK ZINC	F81056-2	2	

2.14 Blade Guide Assembly

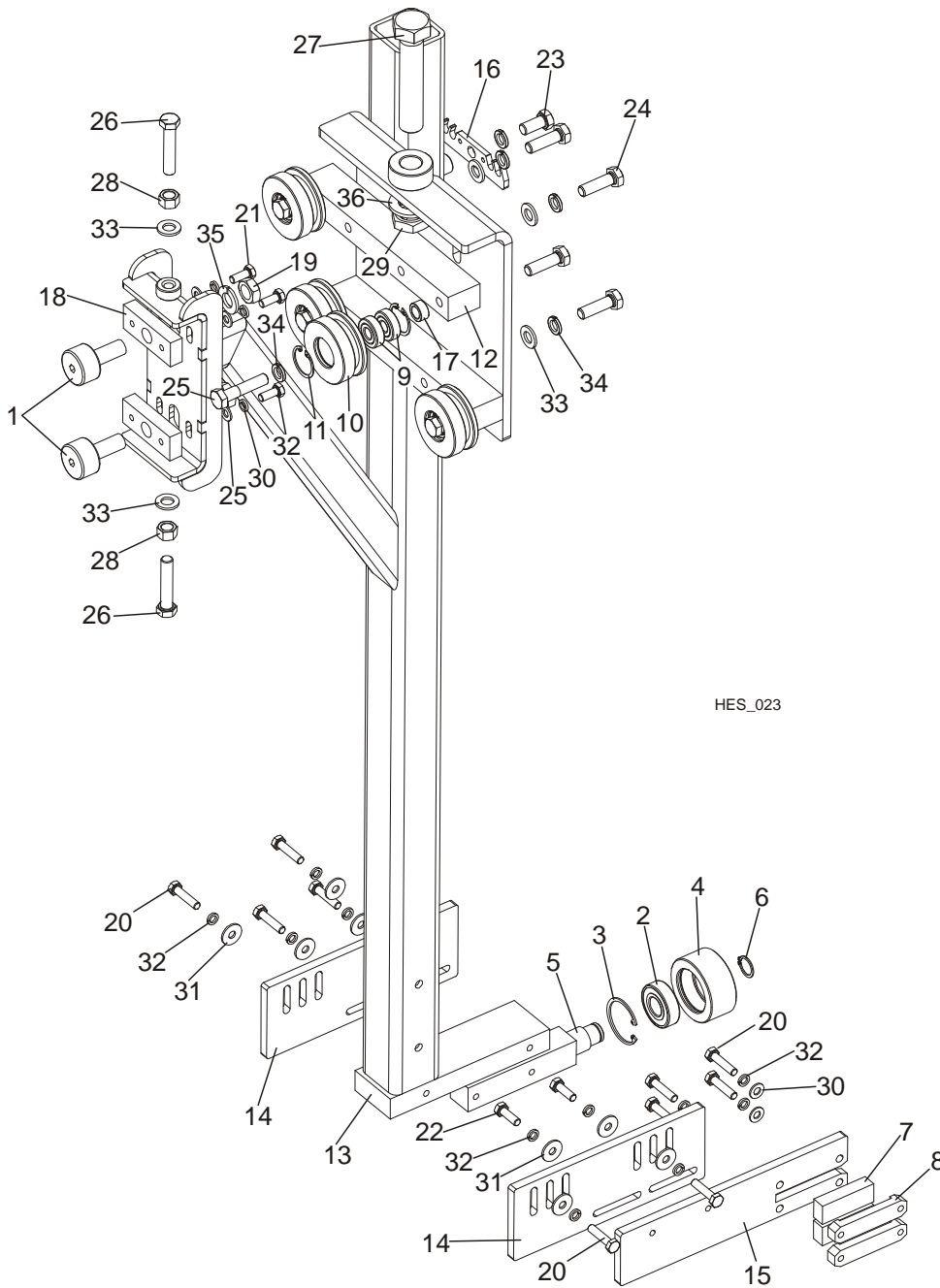

REF.	DESCRIPTION (◆ Indicates Parts Available In Assemblies Only)	PART #	QTY.
	BLADE GUIDE RIGHT WM1000	501565	1
	BLADE GUIDE LEFT WM1000	504435	1
1	BEARING, (MCGILL) CAM FOLLOWER	012797	2
	BLADE STOP ROLLER WM1000 COMPLETE	500380	1
2	BEARING, 6204 2RS-CX	088447	1
3	RING, W47 RETAINING	089653	1

4	ROLLER, WM1000 BLADE STOP	500378-1	1	
5	AXLE, WM1000 BLADE STOP ROLLER MOUNT ZINC	500379-1	1	
6	RING, Z20 RETAINING	F81090-27	1	
7	BLOCK, WM1000 BLADE GUIDE ZINC	501052-1	2	
8	BAR, WM1000 BLADE GUIDE BLOCK RETAINER	501053-1	2	
	ROLLER, BLADE GUIDE COMPLETE	501563	4	
9	BEARING, 6201-2RS CX	089060	2	
10	ROLLER, WM1000 BLADE GUIDE	501562-1	1	
11	RING, W32 RETAINING	F81090-5	2	
12	BAR, WM1000 BLADE GUIDE ROLLER MOUNT	501564-1	2	
13	BRACKET, WM1000 BLADE GUIDE RIGHT	501567-1	1	
	BRACKET, WM1000 BLADE GUIDE LEFT	504434-1	1	
14	PLATE, WM1000 ROLLER BRACKET RETAINING	501571-1	2	
15	BRACKET, WM1000 ROLLER LOWER	501572-1	1	
16	BRACKET, 08B WM1000 CHAIN ZINC	501581-1	1	
17	BUSHING, ϕ 13X ϕ 20X10 WM1000 ZINC	502665-1	4	
18	BAR, WM1000 BLADE GUIDE ROLLER MOUNT	503056-1	2	
19	NUT, 5/8"-18 ZINC	F05010-11	2	
20	BOLT, M8X35 -8.8-HEX HEAD FULL THREAD ZINC	F81002-13	10	
21	BOLT, M8X20-8.8-B-HEX HEAD FULL THREAD ZINC	F81002-4	4	
22	BOLT, M8X25-8.8-B-HEX HEAD FULL THREAD ZINC	F81002-5	2	
23	BOLT, M12X25-8.8-HEX HEAD FULL THREAD ZINC	F81004-31	1	
24	BOLT, M12X40-8.8-HEX HEAD FULL THREAD ZINC	F81004-4	4	
25	BOLT, M12X55 - 8.8 HEX HEAD FULL THREAD ZINC	F81004-43	4	
26	BOLT, M12X60-8.8-HEX HEAD FULL THREAD ZINC	F81004-51	2	
27	BOLT, M24X120 8.8 HEX HEAD FULL THREAD ZINC	F81009-6	1	
28	NUT, M12-8-B HEX ZINC	F81034-1	2	
29	NUT, M24-04-B-HEX THIN ZINC	F81039-3	1	
30	WASHER, 8,4-FLAT ZINC	F81054-1	8	
31	WASHER, 8,5 SPECIAL FLAT ZINC	F81054-11	8	
32	WASHER, 8,2 SPLIT LOCK ZINC	F81054-4	16	
33	WASHER, 13 FLAT ZINC	F81056-1	6	
34	WASHER, 12,2 SPLIT LOCK ZINC	F81056-2	9	
35	WASHER, 16,3 SPLIT LOCK ZINC	F81058-2	2	
36	WASHER, 25 FLAT ZINC	F81061-3	1	

2.15 Blade Guide Drive Assembly

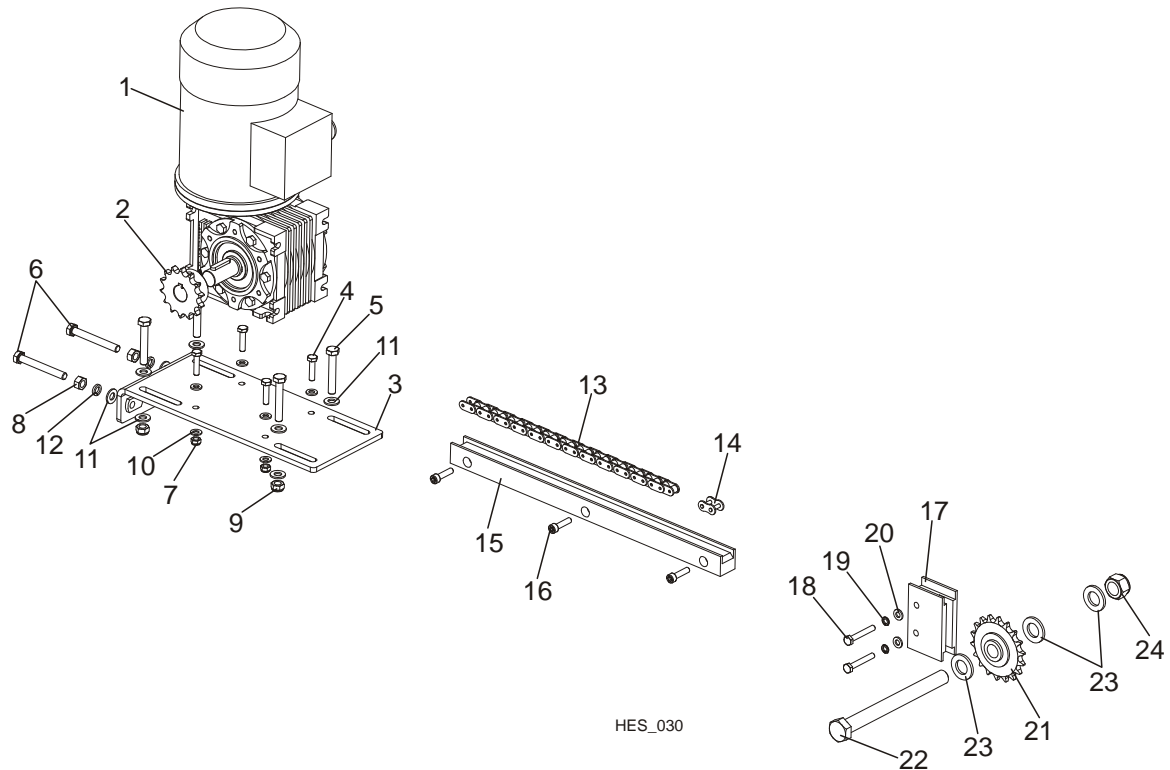

REF.	DESCRIPTION (◆ Indicates Parts Available In Assemblies Only)	PART #	QTY.
	DRIVE ASSEMBLY, WM1000 BLADE GUIDE	504785	2
1	MOTOREDUCER MR-40/21/0,25-1400/K3/V5	100810	1
2	SPROCKET, 14Z08BF119 (ULMER T72504)	502111	1
3	PLATE, WM1000 BLADE GUIDE REDUCER	504784-1	1
4	BOLT, M6X25 -5.8- HEX HEAD FULL THREAD ZINC	F81001-3	4
5	BOLT, M8X50-8.8-HEX HEAD FULL THREAD ZINC	F81002-19	4
6	BOLT, M8X65 8.8 HEX HEAD FULL THREAD ZINC	F81002-9	2
7	NUT, M6-8-B-HEX NYLON ZINC LOCK	F81031-2	4
8	NUT, M8-8-B-HEX ZINC	F81032-1	2
9	NUT, M8-8-B-HEX NYLON ZINC LOCK	F81032-2	4
10	WASHER, 6,4 FLAT ZINC	F81053-1	8
11	WASHER, 8,4-FLAT ZINC	F81054-1	10
12	WASHER, 8,2 SPLIT LOCK ZINC	F81054-4	2
	CHAIN, WM1000 BLADE GUIDE LEFT	504719	1
	CHAIN, WM1000 BLADE GUIDE RIGHT	504721	1
13	CHAIN, 08B-1 - 4.6M WM1000	504718	1
	CHAIN, 08B-1 - 4.35M WM1000	504720	1
14	LINK, 08B-1PZ MASTER	091625	1
15	GUIDE, CHAIN REAR	502784	2
16	BOLT, M6X25 -8.8-SOCKET HEAD ZINC	F81001-41	6
17	COVER, CHAIN UPPER	504564	2

18	BOLT, M6X40-8.8-HEX HEAD FULL THREAD ZINC	F81001-5	4	
19	WASHER, Z 6,1 SPLIT LOCK ZINC	F81053-3	4	
20	WASHER, 6,4 FLAT ZINC	F81053-1	4	
21	SPROCKET, Z18 1/2"X5/16" W/BEARING	088700	2	
22	BOLT, M16X170 HEX HEAD ZINC	F81006-39	2	
23	WASHER, 17 FLAT ZINC	F81058-1	6	
24	NUT, M16-8-HEX NYLON ZINC LOCK	F81036-2	2	

2.16 Blade Guide Tray

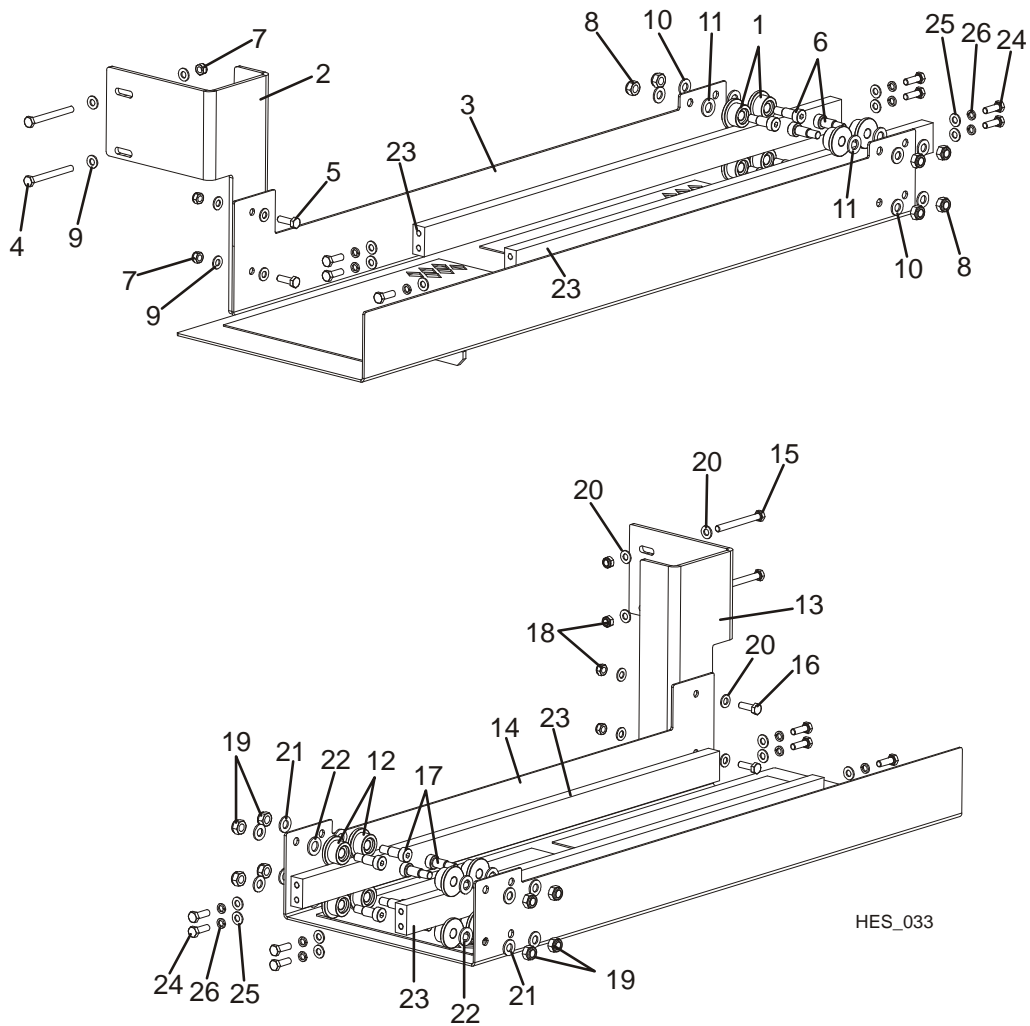

HES_033

REF.	DESCRIPTION (◆ Indicates Parts Available in Assemblies Only)	PART #	QTY.
	TRAY, BLADE GUIDE RIGHT COMPLETE	504183	1
1	ROLLER, TRAY GUIDE	503329	8
2	BRACKET, BLADE GUIDE COVER RIGHT	504184-1	1
3	TRAY, BLADE GUIDE RIGHT	504787-1	1
4	BOLT, M8X80-8.8 HEX HEAD ZINC	F81002-18	2
5	BOLT, M8X25-8.8-B-HEX HEAD FULL THREAD	F81002-5	2
6	SCREW, 12/M10X20 12.9 ISO7379 BOSSARD SHOULDER	F81003-86	8
7	NUT, M8-8-B-HEX NYLON ZINC LOCK	F81032-2	4
8	NUT, M10-8-B -HEX NYLON ZINC LOCK	F81033-1	8
9	WASHER, 8,4-FLAT ZINC	F81054-1	8
10	WASHER, 10,5 FLAT ZINC	F81055-1	8
11	WASHER, 13 FLAT ZINC	F81056-1	8

	TRAY, BLADE GUIDE LEFT COMPLETE	504625	1	
12	ROLLER, TRAY GUIDE	503329	8	
13	BRACKET, BLADE GUIDE COVER LEFT	504621-1	1	
14	TRAY, BLADE GUIDE LEFT	504788-1	1	
15	BOLT, M8X80-8.8 HEX HEAD ZINC	F81002-18	2	
16	BOLT, M8X25-8.8-B-HEX HEAD FULL THREAD ZINC	F81002-5	2	
17	SCREW, 12/M10X20 12.9 ISO7379 BOSSARDSHOULDER	F81003-86	8	
18	NUT, M8-8-B-HEX NYLON ZINC LOCK	F81032-2	4	
19	NUT, M10-8-B -HEX NYLON ZINC LOCK	F81033-1	8	
20	WASHER, 8,4-FLAT ZINC	F81054-1	8	
21	WASHER, 10,5 FLAT ZINC	F81055-1	8	
22	WASHER, 13 FLAT ZINC	F81056-1	8	
23	BAR, BLADE GUIDE COVER	504182-1	4	
24	BOLT, M8X25-8.8-BHEX HEAD ZINC	F81002-5	16	
25	WASHER, 8,4-FLAT ZINC	F81054-1	16	
26	WASHER, 8,2 SPLIT LOCK ZINC	F81054-4	16	

2.17 Motor Assembly, 22kW

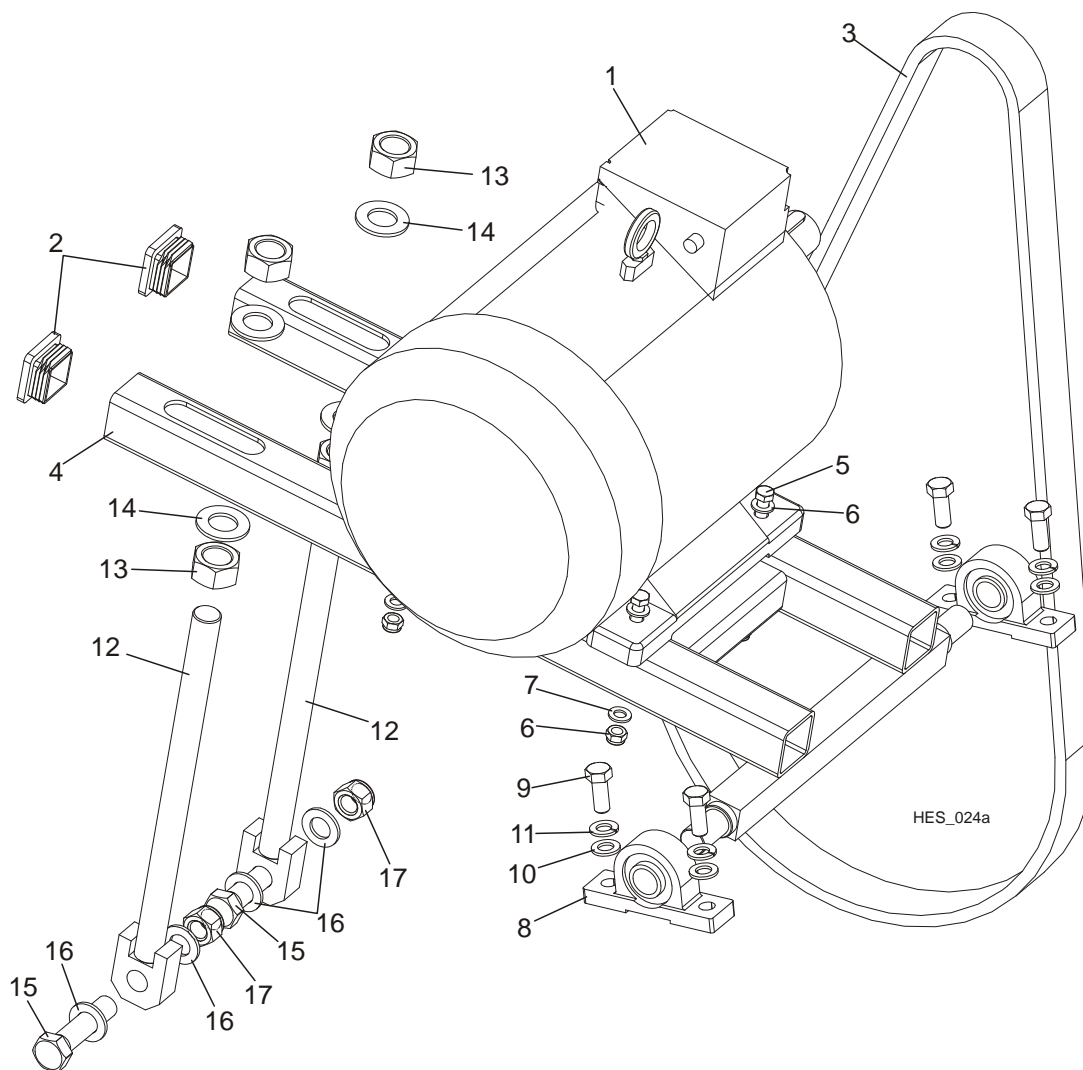

REF.	DESCRIPTION (◆ Indicates Parts Available In Assemblies Only)	PART #	QTY.
	MOTOR ASSEMBLY 22KW WM1000	504776	1
1	MOTOR, 22 KW 1LG4186-4AA60-Z G26+C01 ELECTRIC	093897	1
2	CAP, SR 1540 199211 OUTRIGGER LEG	089710	2
3	V-BELT, 3B BP LE 2640	504790	1
4	MOUNT, 22KW WM1000 MOTOR	504775-1	1
5	BOLT, M12X110-8.8-B-HEX HEAD ZINC	F81004-47	4
6	NUT, M12-8 HEX NYLON ZINC LOCK	F81034-2	4
7	WASHER, 13FLAT ZINC	F81056-1	8
8	BEARING, UCP 206 CX	099254	2
9	BOLT, M16X40-8.8 HEX HEAD FULL THREAD ZINC	F81006-13	4
10	WASHER, 17 FLAT ZINC	F81058-1	4
11	WASHER, 16,3 SPLIT LOCK ZINC	F81058-2	4
12	SCREW, MOTOR TENSION	501800-1	2

WM1000 SAWMILL SAW HEAD*Motor Assembly, 22kW***2**

13	NUT, M30 HEX ZINC	F81038-3	4	
14	WASHER, 31 FLAT ZINC	F81061-9	4	
15	BOLT, M24X100 8.8HEX HEAD ZINC	F81009-10	2	
16	WASHER, 25 FLAT ZINC	F81061-3	4	
17	NUT, M24X2-8-A-HEX NYLON ZINC LOCK	F81039-10	2	

2.18 Hydraulic Blade Tensioner Assembly

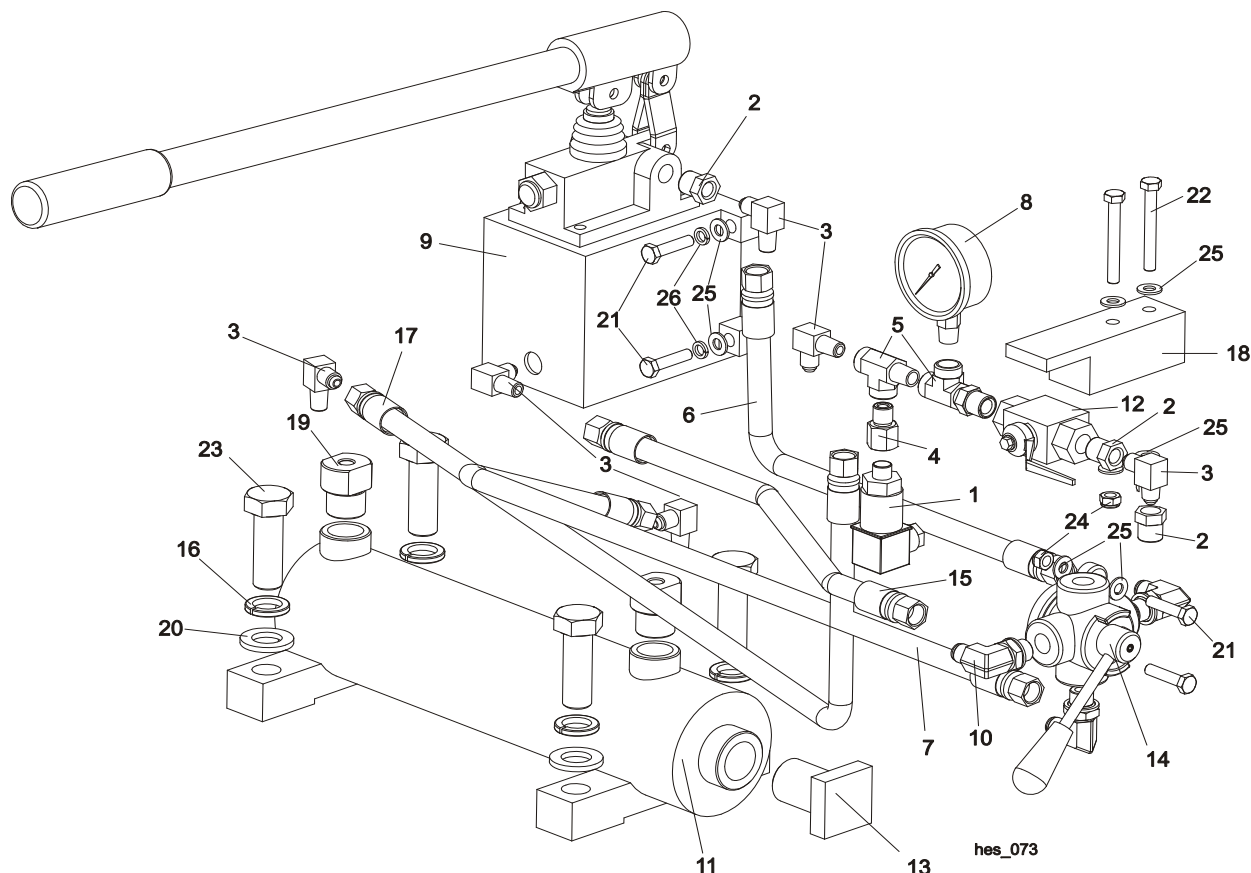

REF.	DESCRIPTION (◆ Indicates Parts Available in Assemblies Only)	PART #	QTY.
	HYDRAULIC BLADE TENSIONER ASSEMBLY WM1000	504325	1
1	PRESSURE SWITCH F4-T-I-M3-16 BAR	504830	1
2	FITTING, 3/8NPT- 1/4NPT REDUCER	015490	4
3	FITTING, LOG CLAMP	015491	7
4	FITTING, PRESSURE SWITCH.504830	507052-1	1
5	FITTING, C3759X4 MALE RUN TEE	P09141	2
6	HOSE, 3/8" SECTION TO OIL FLOW DIVIDER 0,43	089845	1
7	HOSE, 3/8" ZHYD. VALVE TO 1ST TEE CONNECTOR 0,72M	089851	1
8	GAUGE,.-3000PSI HYDRAULIC	090552	1
9	PUMP, PMS12/TNK1 MANUAL W/TANK 1L	092789	1
10	FITTING, 3/8" BSP-9/16" JIC ELBOW	096335	3
11	CYLINDER, CJ7F800X200 „BARTEX"	501386	1
12	VALVE, 3/8 " G BALL	502056	1
13	SCREW, BLADE TENSIONER CYLINDER	502459-1	1
14	VALVE, 4-WAY IDF 4V02C	504324	1
15	HOSE, 3/8 - 365 HYDRAULIC	504704	1
16	WASHER, Z 20,5-SPLIT LOCK ZINC	F81059-1	4
17	HOSE, 3/8 - 830 HYDRAULIC	504707	1
18	CLAMP, BALL VALVE	504709-1	1

WM1000 SAWMILL SAW HEAD*Hydraulic Blade Tensioner Assembly***2**

19	FITTING, M27X2 - 1/4NPT	504710-1	2	
20	WASHER, 21 FLAT ZINC	F81059-2	4	
21	BOLT, M8X35 -8.8-HEX HEAD FULL THREAD ZINC	F81002-13	6	
22	BOLT, M8X65-5,8 HEX HEAD ZINC	F81002-3	2	
23	BOLT, M20X60-8.8-HEX HEAD ZINC	F81007-7	4	
24	NUT, M8-8-B-HEX NYLON ZINC LOCK	F81032-2	4	
25	WASHER, 8,4-FLAT ZINC	F81054-1	12	
26	WASHER, 8,2 SPLIT LOCK ZINC	F81054-4	4	

2.19 Oil Supply Assembly

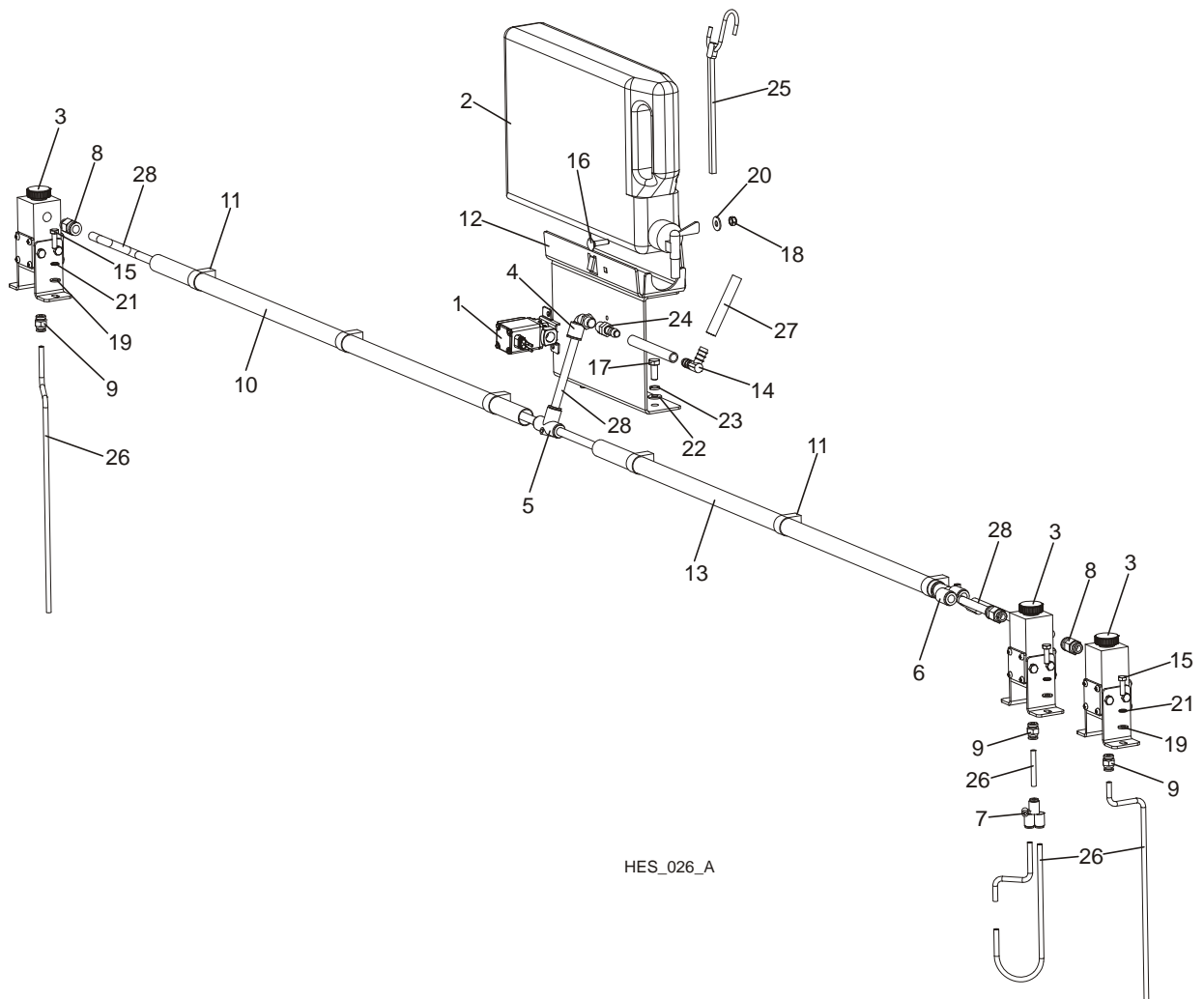

REF.	DESCRIPTION (◆ Indicates Parts Available in Assemblies Only)	PART #	QTY.	
	OIL SUPPLY ASSEMBLY	504320	1	
1	SOLENOID, WATER LUBE	509113	1	
2	BOTTLE, 5L OIL	049119	1	
3	DISPENSER, OIL	502660	3	
4	FITTING, KQ2L 10-02S 1/4"-18 UNF ELBOW	503972	1	
5	FITTING, KQ2T 10-00 1/4" TYPE-T	503973	1	
6	FITTING, KQ2U 10-00 1/4" TYPE-Y	503974	1	
7	FITTING, KQ2U 06-00 1/4" TYPE-Y	503975	1	
8	FITTING, 10MM (KAH10-U02) STRAIGHT	503976	3	
9	FITTING, 6MM (KAH6-U02) STRAIGHT	503977	3	
10	TUBE, PVC-22, L=935MM	504318	1	
11	HOLDER, U-22 TUBE	504319	6	
12	BRACKET, WM1000 OIL BOTTLE	504322-1	1	

13	TUBE, PVC-22, L=850MM	504702	1	
14	FITTING, 90 ^o -10MM ELBOW	504800	1	
15	BOLT, M6X20-8.8 HEX HEAD FULL THREAD ZINC	F81001-2	6	
16	BOLT, M6X25-8.8-CARRIAGE HEAD ZINC	F81001-20	1	
17	BOLT, M8X20-8.8-B-HEX HEAD FULL THREAD ZINC	F81002-4	2	
18	NUT, M6-8-B-HEX NYLON ZINC LOCK	F81031-2	1	
19	WASHER, 6,4 FLAT ZINC	F81053-1	6	
20	WASHER, 6,5 SPECIAL FLAT ZINC	F81053-11	1	
21	WASHER, Z 6,1 SPLIT LOCK ZINC	F81053-3	6	
22	WASHER, 8,4-FLAT ZINC	F81054-1	2	
23	WASHER, 8,2SPLIT LOCK ZINC	F81054-4	2	
24	FITTING, 3/8" BARB 1/4" NPT MALE NYLON	P04682	1	
25	STRAP, 24" RUBBER WITH HOOKS	P11258	1	
26	HOSE, 6MM AIR	R01869-3	2,5mb	
27	TUBING, WATER LUBE	R01885	0,2m	
28	HOSE, 12X10 25M POLYURETHANE	R80588-4	2,5mb	

2.20 Blade Wiper Assembly

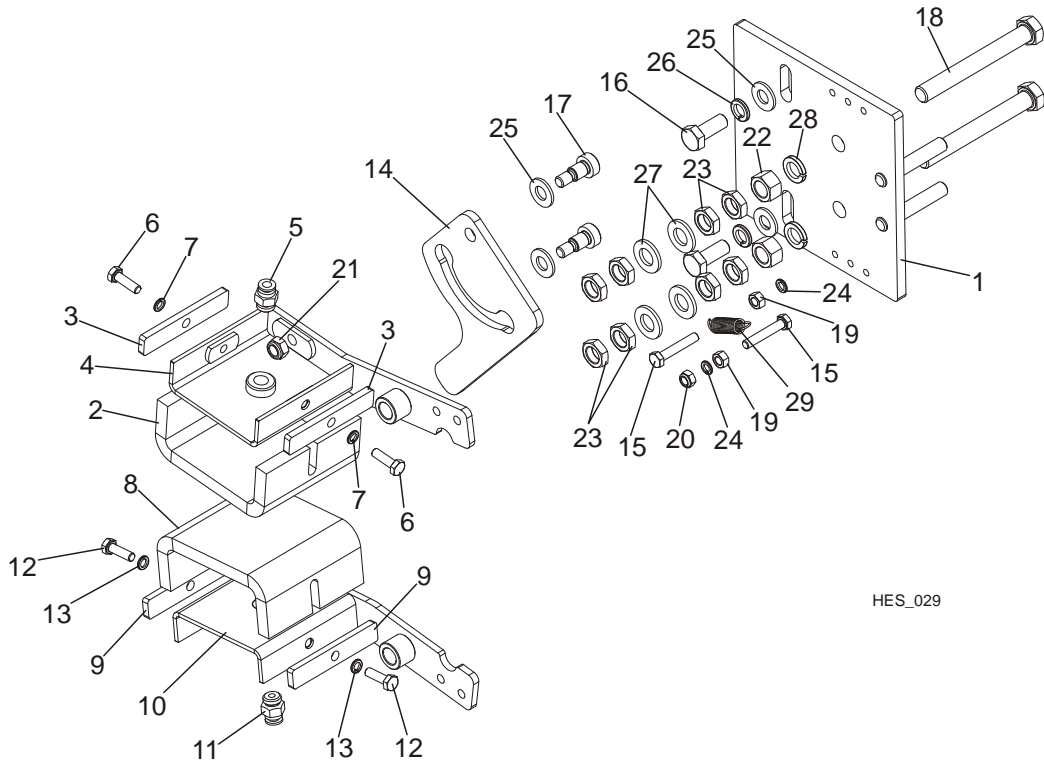

HES_029

REF.	DESCRIPTION (◆ Indicates Parts Available In Assemblies Only)	PART #	QTY.
	BLADE WIPER ASSEMBLY	500830	1
1	BRACKET, BLADE WIPER KIT ZINC	500825-1	1
	BLADE WIPER ASSEMBLY, UPPER	500986	1
2	PAD, FELT	500808	1
3	FLAT BAR, FELT MOUNT ZINC	500813-1	2
4	ARM, FELT MOUNT ZINC RIGHT	500832-1	1
5	FITTING, 6MM (KAH06-U02) STRAIGHT	503977	1
6	BOLT, M6x20-8.8-HEX HEAD FULL THREAD ZINC	F81001-2	2
7	WASHER, Z 6,1 SPLIT LOCK ZINC	F81053-3	2
	BLADE WIPER ASSEMBLY, LOWER	500987	1
8	PAD, FELT	500808	1
9	FLAT BAR, FELT MOUNT ZINC	500813-1	2
10	ARM, FELT MOUNT ZINC LEFT	500833-1	1
11	FITTING, 6MM (KAH06-U02) STRAIGHT	503977	1
12	BOLT, M6x20-8.8-HEX HEAD FULL THREAD ZINC	F81001-2	2
13	WASHER, Z 6,1 SPLIT LOCK ZINC	F81053-3	2
14	CAM, BLADE WIPER ASSEMBLY	502666-1	1
15	BOLT, M6X35 8.8HEX HEAD ZINC	F81001-71	2
16	BOLT, M10X25-8.8-HEX HEAD FULL THREAD ZINC	F81003-11	2
17	SCREW, 10/M8X12-12.9 ISO-7379 SHOULDER	F81003-62	2
18	BOLT, M12X100 8.8 HEX HEAD FULL THREAD ZINC	F81004-45	2

19	NUT, M6-8-HEX ZINC	F81031-1	2	
20	NUT, M6-8-B-HEX NYLON ZINC LOCK	F81031-2	1	
21	NUT, M8-8-B-HEX NYLON ZINC LOCK	F81032-2	2	
22	NUT, M12-8-B HEX ZINC	F81034-1	2	
23	NUT, M12 THIN ZINC	F81034-6	8	
24	WASHER, Z 6,1 SPLIT LOCK ZINC	F81053-3	2	
25	WASHER, 10,5 FLAT ZINC	F81055-1	4	
26	WASHER, 10.2 SPLIT LOCK ZINC	F81055-2	2	
27	WASHER, 13 FLAT ZINC	F81056-1	4	
28	WASHER, Z12,2 SPLIT LOCK ZINC	F81056-2	2	
29	SPRING, 1,6X12X38 EXTENSION	092208	1	

2.21 Saw Head Covers

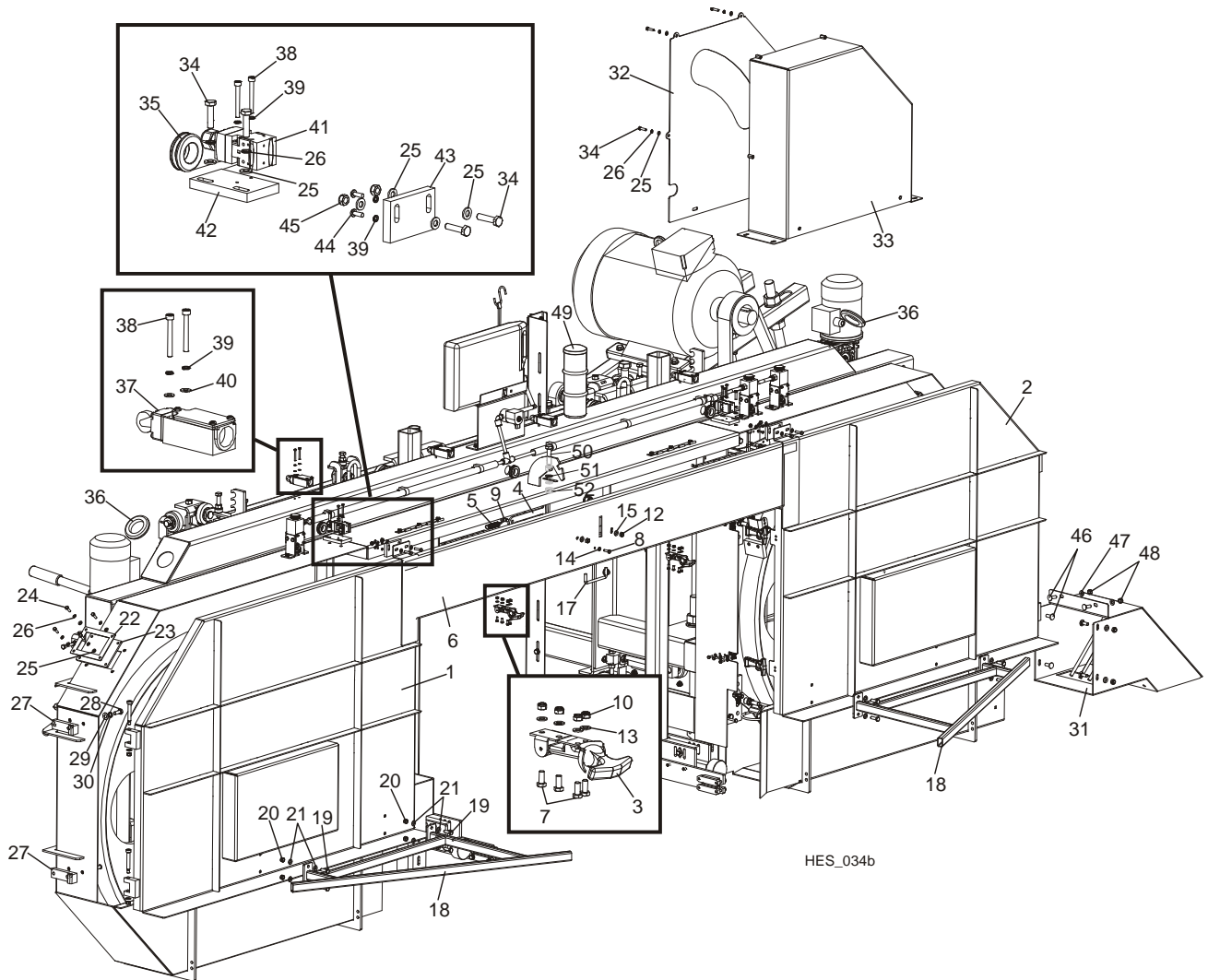

HES_034b

REF.	DESCRIPTION (◆ Indicates Parts Available In Assemblies Only)	PART #	QTY.	
1	COVER, WM1000 SAW HEAD LEFT	501744-1	1	
2	COVER, WM1000 SAW HEAD RIGHT	501745-1	1	
	COVER, WM1000 SAW HEAD FRONT	504178	1	
3	LATCH, FLEXIBLE DRAW	014829	2	
4	PAWL, LOCKING PTD	090643-1	1	
5	SPRING, 1,6X12X38 EXTENSION	092208	1	
6	COVER, WM1000 SAW HEAD FRONT	504177-1	1	
7	BOLT, M5X12-5.8-HEX HEAD FULL THREADZINC	F81000-5	8	
8	BOLT, M6X20-8.8-HEX HEAD FULL THREAD ZINC	F81001-2	1	
9	SCREW, 10/M8X12-12.9 ISO-7379 SHOULDER	F81003-62	2	
10	NUT, M5-8- DIN 985 ZINC	F81030-2	8	
11	NUT, M6-8-B-HEX NYLON ZINC LOCK	F81031-2	2	
12	NUT, M8-8-B-HEX NYLON ZINC LOCK	F81032-2	2	
13	WASHER, 5,3 FLAT ZINC	F81052-1	8	

14	WASHER, 6,4 FLAT ZINC	F81053-1	2	
15	WASHER, 8,4-FLAT ZINC	F81054-1	2	
16	WASHER, 10,5 FLAT ZINC	F81055-1	2	
17	HANDLE, W/BOLTS	P08065	1	
	GUARD, WM1000 SAW HEAD SAFETY FRONT COMPLETE	504510	2	
18	GUARD, SAW HEAD SAFETY FRONT	504584-1	1	
19	BOLT, M8X25-8.8-B-HEX HEAD FULL THREAD ZINC	F81002-5	4	
20	NUT, M8-8-B-HEX NYLON ZINC LOCK	F81032-2	4	
21	WASHER, 8,4-FLAT ZINC	F81054-1	8	
22	VIEWFINDER	504146	2	
23	FRAME, VIEWFINDER MOUNTING	504147-1	2	
24	BOLT, M6X20-8.8-HEX HEAD FULL THREAD ZINC	F81001-2	8	
25	WASHER, 6,4 FLAT ZINC	F81053-1	20	
26	WASHER, Z 6,1 SPLIT LOCK ZINC	F81053-3	20	
27	BRACKET, WM1000 COVER HINGE INNER	502458	4	
28	BOLT, M10X25-8.8-HEX HEAD FULL THREAD ZINC	F81003-11	8	
29	WASHER, 10,5 FLAT ZINC	F81055-1	8	
30	WASHER, 10,2 SPLIT LOCK ZINC	F81055-2	8	
31	CHUTE, WM1000 SAWDUST	502017-1	1	
32	PLATE, COVER REAR	502021-1	1	
33	COVER, WM1000 UPPER	502022-1	1	
34	BOLT, M6X25 -5.8- HEX HEAD FULL THREAD ZINC	F81001-3	12	
35	GROMMET, RUBBER 22MM ID	087400	3	
36	GROMMET, RUBBER 55MM	085614	2	
37	SWITCH, GLCB01A2B (HONEYWELL) LIMIT	086469	4	
38	BOLT, M4X35 -8.8- HEX SOCKET HEAD ZINC	F81011-34	12	
39	WASHER, Z 4,1 SPLIT LOCK ZINC	F81051-1	8	
40	WASHER, 4,3 FLAT ZINC	F81051-2	8	
41	SWITCH, AZ17-11ZRK SAFETY	094232	2	
42	FLAT BAR, LIMIT SWITCH GUIDE MOUNTING	504189-1	2	
43	FLAT BAR, LIMIT SWITCH GUIDE MOUNTING	504669-1	2	
44	SCREW, M4X12 -5,8-B- CROSS RECESSED PAN HEX	F81011-43	4	
45	NUT, M6-8-B-HEX NYLON ZINC LOCK	F81031-2	4	
46	BOLT, M8 X 20 FE/ZN5, PN-M/82406	F81002-11	6	
47	WASHER, 8,4 FLAT ZINC	F81054-1	6	
48	NUT, M8-8-B HEX NYLON ZINC LOCK	F81032-2	6	
49	COLUMN, SIGNAL, RED WITH SOUND	503550	1	
50	BOLT M16X220 8.8- A2E FULL THREAD	F81006-43	1	
51	WASHER, 17 FLAT ZINC	F81058-1	2	
52	NUT, M16, HEXAGON, GRADE 5.8 PLAIN	F81036-1	2	

2.22 Blade Motor Cage Covers

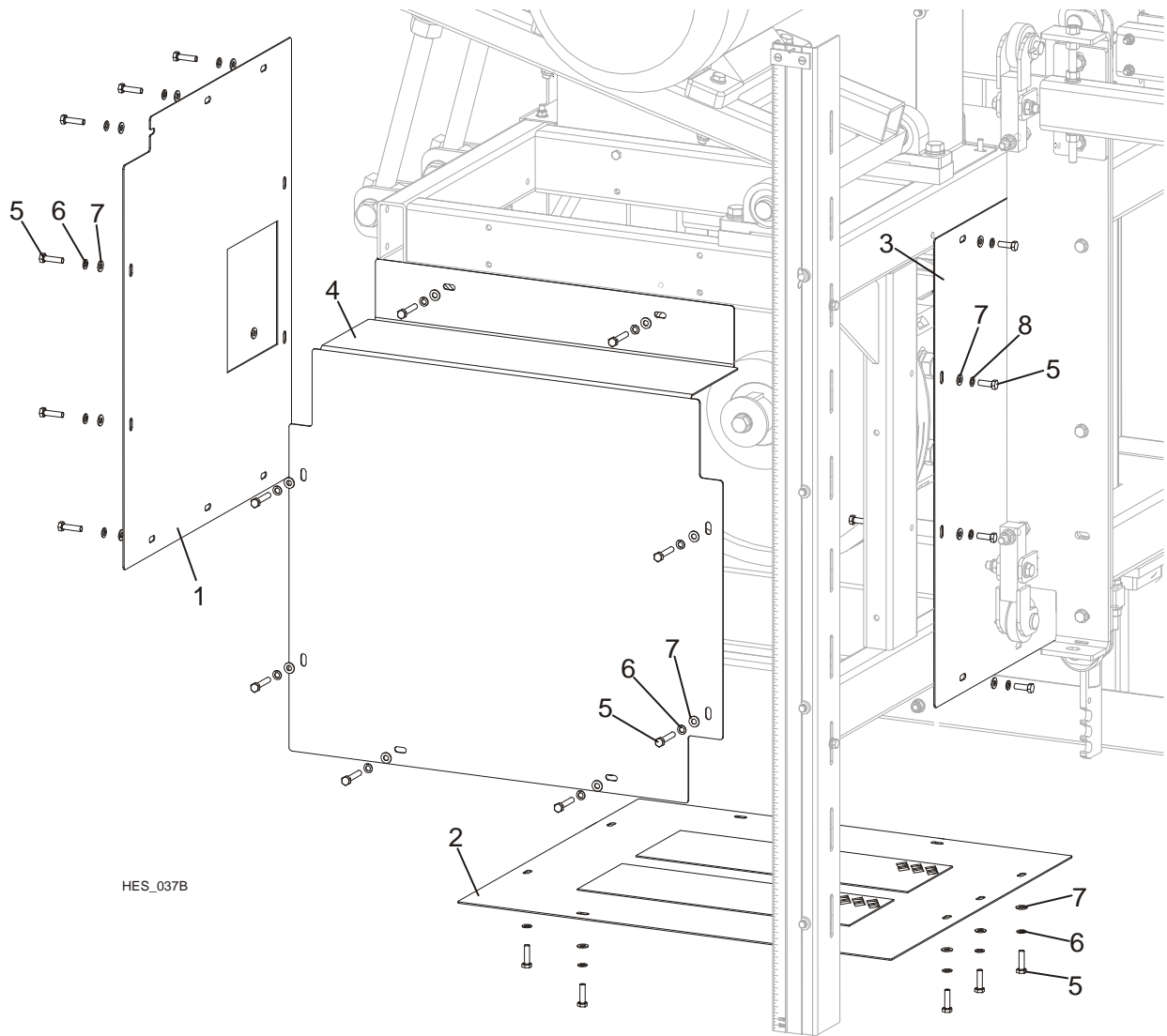

REF.	DESCRIPTION (◆ Indicates Parts Available in Assemblies Only)	PART #	QTY.
1	PLATE, WM1000 COVER SIDE	502020-1	1
2	PLATE, WM1000 COVER	504161-1	1
3	PLATE, WM1000 COVER SIDE RIGHT	504162-1	1
4	PLATE, WM1000 COVER REAR	504163-1	1
5	BOLT, M8X25-8.8-B HEX HEAD FULL THREAD	F81002-5	35
6	WASHER 8,2 SPLIT LOCK ZINC	F81054-4	35
7	WASHER, 8,4-FLAT ZINC	F81054-1	35

2.23 Scale

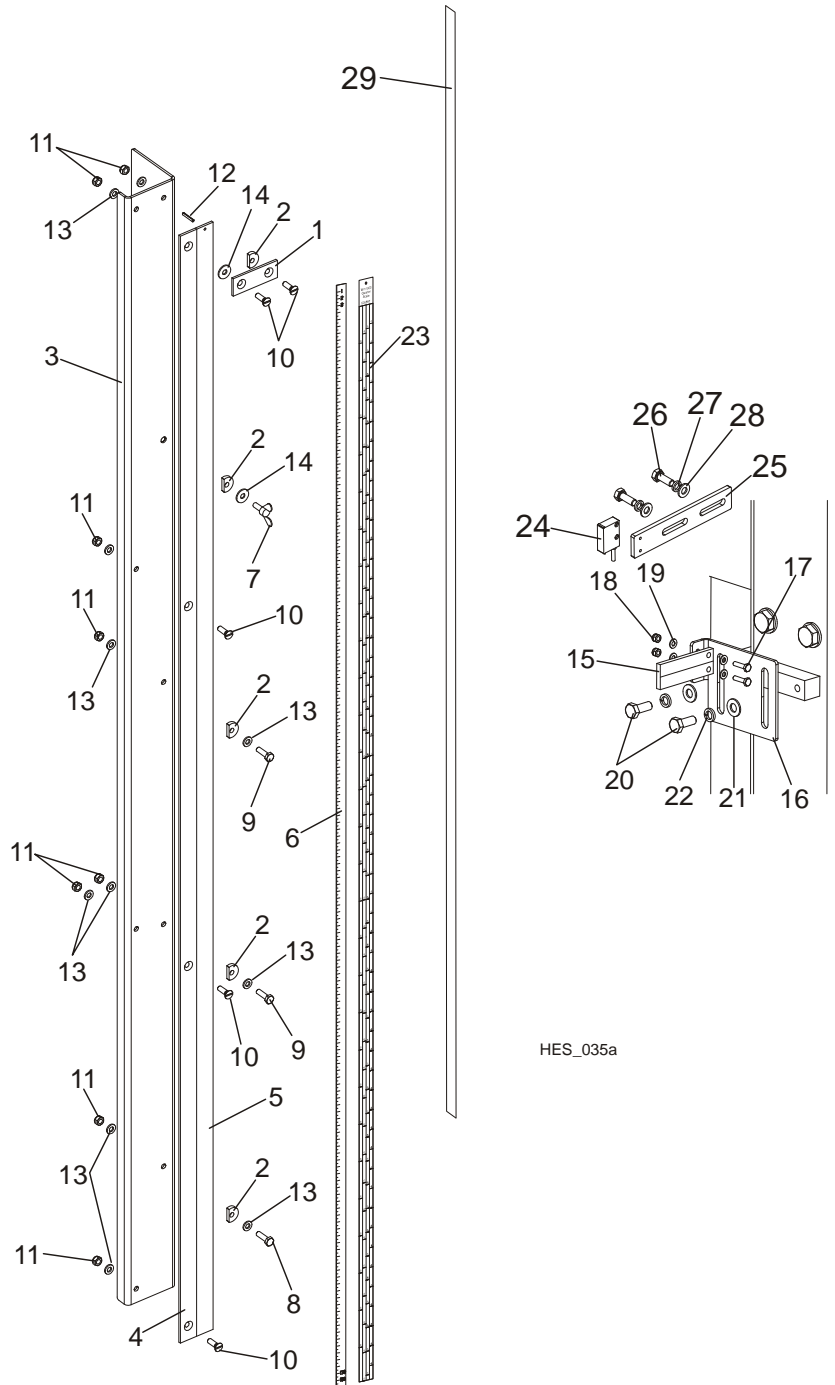

HES_035a

REF.	DESCRIPTION (◆ Indicates Parts Available In Assemblies Only)	PART #	QTY.
	SCALE WM1000 COMPLETE	504605	1
1	BAR, SCALE MOUNT	093134	1
2	WASHER, 6.2X20X4.5 SPECIAL	503098	5
3	PLATE, SCALE MOUNTING	504607-1	1
4	FLAT BAR, WM1000 SCALE	504608	1

5	BAR, WM1000 INCH SCALE	504609	1	
6	SCALE, 0-180CM WM1000	504789	1	
7	BOLT, M6X16 BN276 DIN 316	F81001-16	1	
8	BOLT, M6X20-8.8-HEX HEAD FULL THREAD ZINC	F81001-2	1	
9	BOLT, M6X25 -5.8- HEX HEAD FULL THREAD ZINC	F81001-3	2	
10	SCREW, M6X20- 4.8-B FZINC	F81001-31	5	
11	NUT, M6-8-B-HEX NYLON ZINC LOCK	F81031-2	8	
12	PIN, 3X20 GEOMET ROLL	F81044-5	1	
13	WASHER, 6,4 FLAT ZINC	F81053-1	11	
14	WASHER, 6,5 SPECIAL FLAT ZINC	F81053-11	2	
	INDICATOR, WM1000 SCALE COMPLETE	504610	1	
15	INDICATOR, SCALE	094821	1	
16	BRACKET, WM1000 SCALE INDICATOR	504616-1	1	
17	BOLT, M4X16 5.8 HEX HEAD FULL THREAD ZINC	F81011-6	2	
18	NUT, M4-BHEX NYLON ZINC LOCK	F81029-1	2	
19	WASHER, 4,3 FLAT ZINC	F81051-2	4	
20	BOLT, M8X20-8.8-B-HEX HEAD FULL THREAD	F81002-4	2	
21	WASHER, 8,4-FLAT ZINC	F81054-1	2	
22	WASHER, 8,2 SPLIT LOCK ZINC	F81054-4	2	
23	SCALE, WM1000 QUARTER	506597	1	
24	SENSOR, MSK-320	096014	1	
25	MOUNTING BAR, SESNOR WM1000-ZINC	504661-1	1	
26	BOLT, M8X20MM, HEX HEAD,GR 5.8 ZINC	F81002-4	2	
27	WASHER 8,2 FE/ZN9	F81054-4	2	
28	WASHER, 8.4 FLAT,ZINC	F81054-1	2	
29	TAPE, MB320 MAGNETIC (1M)	096014-1000	1	

2.24 Decals

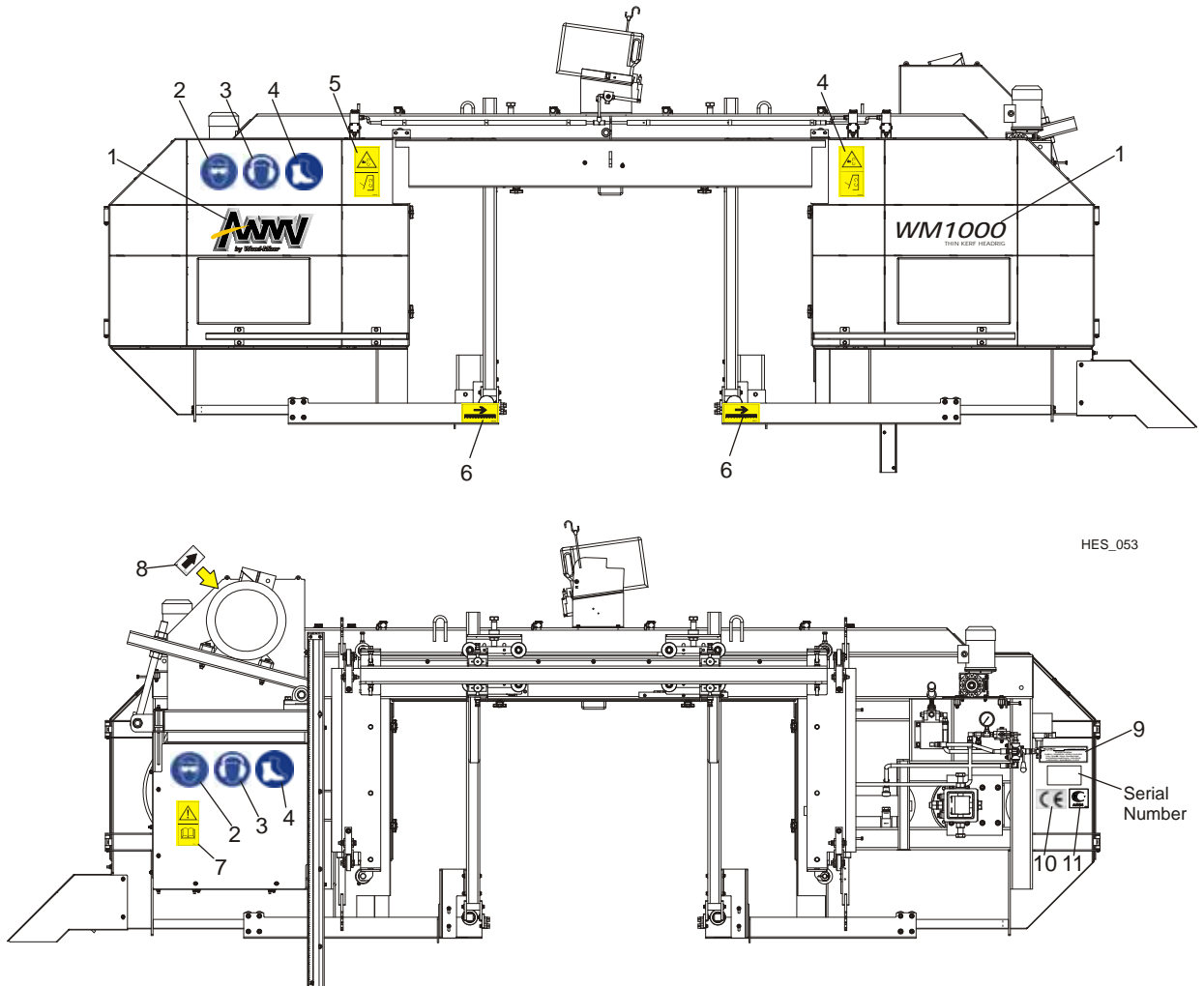

REF.	DESCRIPTION (◆ Indicates Parts Available in Assemblies Only)	PART #	QTY.
	DECAL KIT, WM1000	505052	1
1	DECAL, WM1000 SAWMILL	505053	1
2	DECAL, EYE PROTECTION WARNING (PICTOGRAM)	S12004G	2
3	DECAL, EAR PROTECTION WARNING (PICTOGRAM)	S12005G	2
4	DECAL, USE SAFETY BOOTS (PICTOGRAM)	501465	2
5	DECAL, SAWMILL COVERS CAUTION	099220	2
6	DECAL, BLADE MOVEMENT DIRECTION (PICTOGRAM)	096321	2
7	DECAL, READ OPERATOR'S MANUAL (PICTOGRAM)	096317	1
8	DECAL, 1465 RPM MOTOR DIRECTION	S200971	1
9	DECAL, INTERNATIONAL SAWMILL NAME	501466	1
10	DECAL, CE CERTIFIED SAWMILL (SMALL)	P85070	1
11	DECAL, RUSSIAN SAFETY CERTIFICATION	099401	1
	DECAL, HIGH VOLTAGE INSIDE THE ELECTRIC BOX (PICTOGRAM)	096316	2
	DECAL, REMOVE THE PLUG BEFORE OPENING THE BOX (PICTOGRAM)	096319	2

SECTION 3 SAWMILL MAST

3.1 Track Roller Assembly

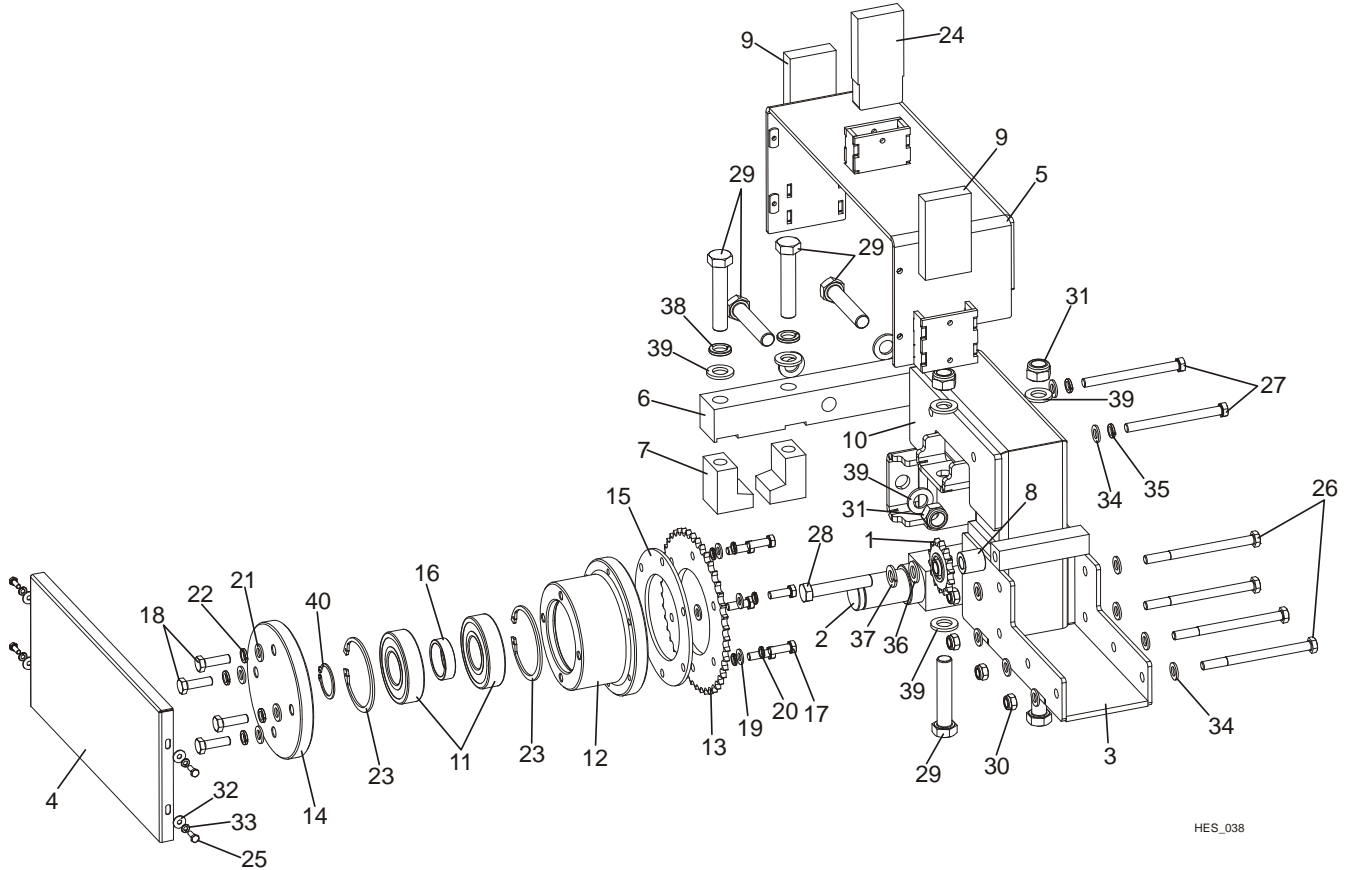

HES_038

REF.	DESCRIPTION (◆ Indicates Parts Available In Assemblies Only)	PART #	QTY.
	TRACK ROLLER ASSEMBLY, WM1000 COMPLETE RIGHT	502770	2
	TRACK ROLLER ASSEMBLY, WM1000 COMPLETE LEFT	502771	2
1	SPROCKET, Z14 5/8"x3/8" W/BEARING	088867	1
2	SHAFT, WM1000 TRACK ROLLER	500331-1	1
3	BRACKET, MOUNTING TRACK ROLLER WM1000	502470-1	1
4	GUARD, TRACK ROLLER WM1000	502474-1	1
5	COVER, TRACK ROLLER WM1000	502477-1	1
6	BAR, WM1000 SUPPORT BLOCK	502478-1	1
7	BLOCK, WM1000 SUPPORT ZINC	502479-1	2
8	ROD, WM1000 BLADE GUIDE MOUNT	502776-1	1
9	SCRAPER WM1000	503261	2
10	PLATE, MOUNTING BRACKET SIDE WM1000	504407-1	1
	WHEEL, WM1000 SAW HEAD TRACK COMPLETE	504675	1
11	BEARING, 6309 2RSR FAG	096107	2
12	WHEEL, WM1000 SAW HEAD TRACK	500332-1	1
13	SPROCKET SPEC. 44Z 10B DIA. 120-WM1000 SPECIAL	502769-1	1
14	COVER, WM1000 TRACK WHEEL ZINC	503474-1	1
15	PLATE, POWER FEED SPROCKET SPACER	503489-1	1

16	BUSHING, $\phi 46;\phi 56;15$ - WM1000 SPACER	504676-1	1	
17	BOLT, M10x30-5.8-HEX HEAD FULL THREAD ZINC	F81003-2	6	
18	BOLT, M12x40-8.8-HEX HEAD FULL THREAD ZINC	F81004-4	4	
19	WASHER, 10,5 FLAT ZINC	F81055-1	6	
20	WASHER, 10,2 SPLIT LOCK ZINC	F81055-2	6	
21	WASHER, 13 FLAT ZINC	F81056-1	4	
22	WASHER, Z12,2 SPLIT LOCK ZINC	F81056-2	4	
23	RING, W100 SPRING RETAINING	F81090-10	2	
24	SCRAPER, WM1000 UPPER	504691	1	
25	BOLT, M6x16 8.8 Fe/Zn5 PN-M/82105	F81001-15	4	
26	BOLT, M12x160-8.8-HEX HEAD ZINC	F81004-13	4	
27	BOLT, M12x140-8.8-HEX HEAD ZINC	F81004-35	2	
28	BOLT, M16x90 -8.8-HEX HEAD ZINC	F81006-17	1	
29	BOLT, M20X100-8.8-HEX HEAD ZINC	F81007-6	6	
30	BOLT, M12-8 HEX NYLON ZINC LOCK	F81034-2	4	
31	BOLT, M20-8-A-HEX NYLON ZINC LOCK	F81037-2	4	
32	WASHER, 6,5 SPECIAL FLAT	F81053-11	4	
33	WASHER, 6,1 DIN127(A2-3) SPLIT LOCK STAINLESS STEEL	F81053-4	4	
34	WASHER, 13 FLAT ZINC	F81056-1	10	
35	WASHER, Z12,2 SPLIT LOCK ZINC	F81056-2	2	
36	WASHER, 17 FLAT ZINC	F81058-1	1	
37	WASHER, 16,3 SPLIT LOCK ZINC	F81058-2	1	
38	WASHER, 20,5-SPLIT LOCK ZINC	F81059-1	2	
39	WASHER, 21 FLAT ZINC	F81059-2	10	
40	RING, Z45 SPRING RETAINING	F81090-32	1	

3.2 Power Feed Assembly

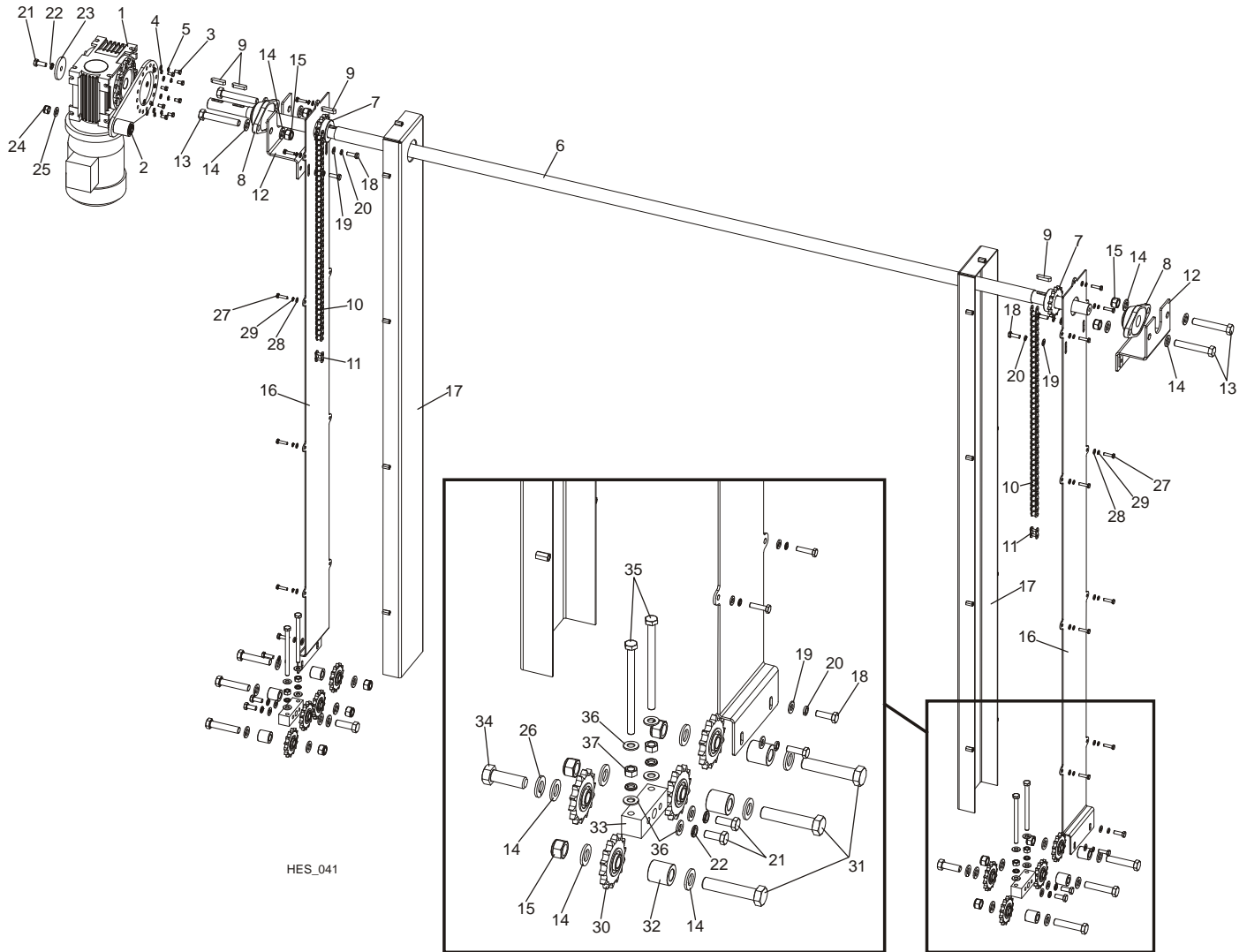

HES_041

REF.	DESCRIPTION (◆ Indicates Parts Available In Assemblies Only)	PART #	QTY.
	POWER FEED GEAR BOX ASSEMBLY WM1000	504629	1
1	MOTOREDUCER, MR-63/32/0.75-1400/F3/V6	502773	1
2	ARM, MR-63 WM1000 REACTION	504176	1
3	BOLT, M6x12-8.8-HEX HEAD FULL THREAD ZINC	F81001-7	8
4	WASHER, 6,4 FLAT ZINC	F81053-1	8
5	WASHER, Z 6,1 SPLIT LOCK ZINC	F81053-3	8
6	SHAFT, WM1000 POWER FEED	502774-1	1
7	SPROCKET, 15Z10B n32 (T43994,T31041)	502772	2
8	BEARING, UCFL 206 CX-WM1000 ASSEMBLY	090851	1
9	KEY, A10x8x40 WM1000 PARALLEL	502045	4
	CHAIN, WM1000 POWER FEED	504717	2
10	CHAIN, 10B-1 - 8.3m WM1000	504716	1
11	LINK, 10B-1Pz MASTER	088671	1
12	PLATE, COVER MOUNTING	503413-1	2

13	BOLT, M16x100-8.8-HEX HEAD FULL THREAD ZINC	F81006-2	4	
14	WASHER, 17 FLAT ZINC	F81058-1	22	
15	NUT, M16-8-HEX NYLON ZINC LOCK	F81036-2	10	
16	PLATE, WM1000 COVER REAR	503415-1	2	
17	COVER, WM1000 POWER FEED	504630-1	1	
18	BOLT, M8x25-8.8-B-HEX HEAD FULL THREAD ZINC	F81002-5	8	
19	WASHER, 8,4- FLAT ZINC	F81054-1	8	
20	WASHER, 8,2 SPLIT LOCK ZINC	F81054-4	8	
21	BOLT, M10x25 8.8 HEX HEAD FULL THREAD	F81003-31	5	
22	WASHER, 10,2 SPLIT LOCK ZINC	F81055-2	9	
23	WASHER, IDLE BLADE WHEEL RETAINING - ZINC	088957-1	1	
24	NUT, M12-8 HEX NYLON ZINC LOCK	F81034-2	1	
25	WASHER, 13 FLAT ZINC	F81056-1	1	
26	WASHER, 16,3 SPLIT LOCK ZINC	F81058-2	2	
27	BOLT, M6x25 -5.8- HEX HEAD FULL THREAD ZINC	F81001-3	18	
28	WASHER, 6,4 FLAT ZINC	F81053-1	18	
29	WASHER, Z 6,1 SPLIT LOCK ZINC	F81053-3	18	
30	SPROCKET, Z14 5/8"x3/8" W/BEARING	088867	8	
31	BOLT, M16x80 8.8-B- HEX HEAD FULL THREAD ZINC	F81006-11	6	
32	BUSHING, ϕ 30x16.5x30 SPACER	502776-1	6	
33	BLOCK, SPROCKET WM1000 MOUNTING- ZINC	502777-1	2	
34	BOLT, M16x50-8.8-HEX HEAD FULL THREAD ZINC	F81006-7	2	
35	BOLT, M10x140-8.8 HEX HEAD ZINC	F81003-5	4	
36	WASHER, 10,5 FLAT ZINC	F81055-1	12	
37	NUT, M10-8-B-HEX ZINC	F81033-3	4	

3.3 Saw Head Support Rollers

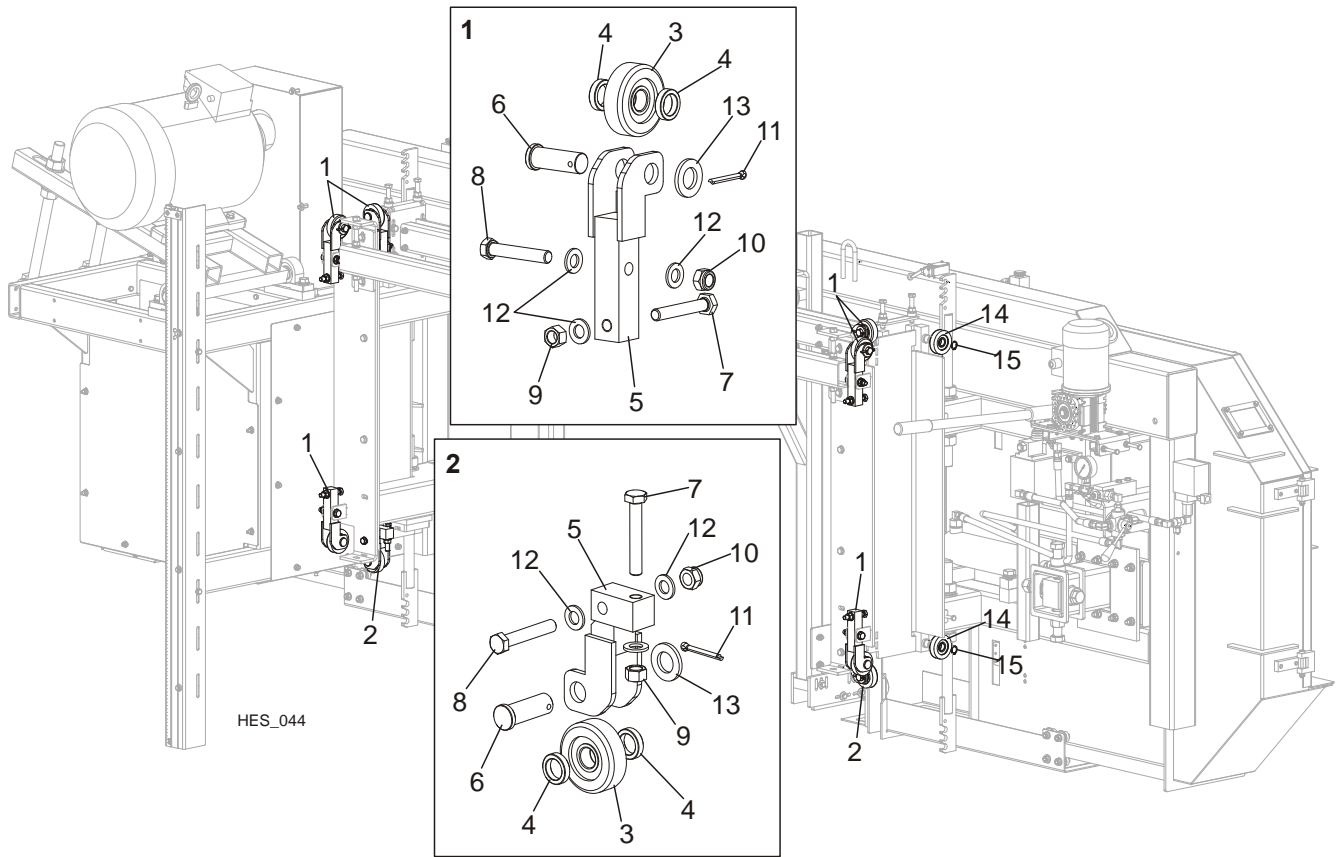

REF.	DESCRIPTION (◆ Indicates Parts Available In Assemblies Only)	PART #	QTY.
1	BRACKET, WM1000 UPPER SUPPORT ROLLER COMPLETE	503484	6
2	BRACKET, WM1000 LOWER SUPPORT ROLLER COMPLETE	503487	2
3	ROLLER, R-68,5M - WM1000 METAL	503475	1
4	BUSHING, $\phi 21 \times \phi 30 \times 7.2$ ZINC	503478-1	2
5	BRACKET, WM1000 UPPER SUPPORT ROLLER ZINC	503482-1	1
	GUIDE, LOWER ROLLER	503477-1	1
6	PIN, WM1000 REACTION ARM ZINC	504173-1	1
7	BOLT, M12x75-8.8HEX HEAD FULL THREAD ZINC	F81004-10	1
8	BOLT, M12x70 8.8 HEX HEAD ZINC	F81004-39	1
9	NUT, M12-8-B HEX ZINC	F81034-1	1
10	NUT, M12-8 HEX NYLON ZINC LOCK	F81034-2	1
11	PIN, S-Zn 5x40 COTTER	F81043-31	1
12	WASHER, 13 FLAT ZINC	F81056-1	3
13	WASHER, 21 FLAT ZINC	F81059-2	1
14	ROLLER, R-68,5M - WM1000 METAL	503475	4
15	RING, Z20 RETAINING	F81090-27	4

3.4 Up/Down Drive

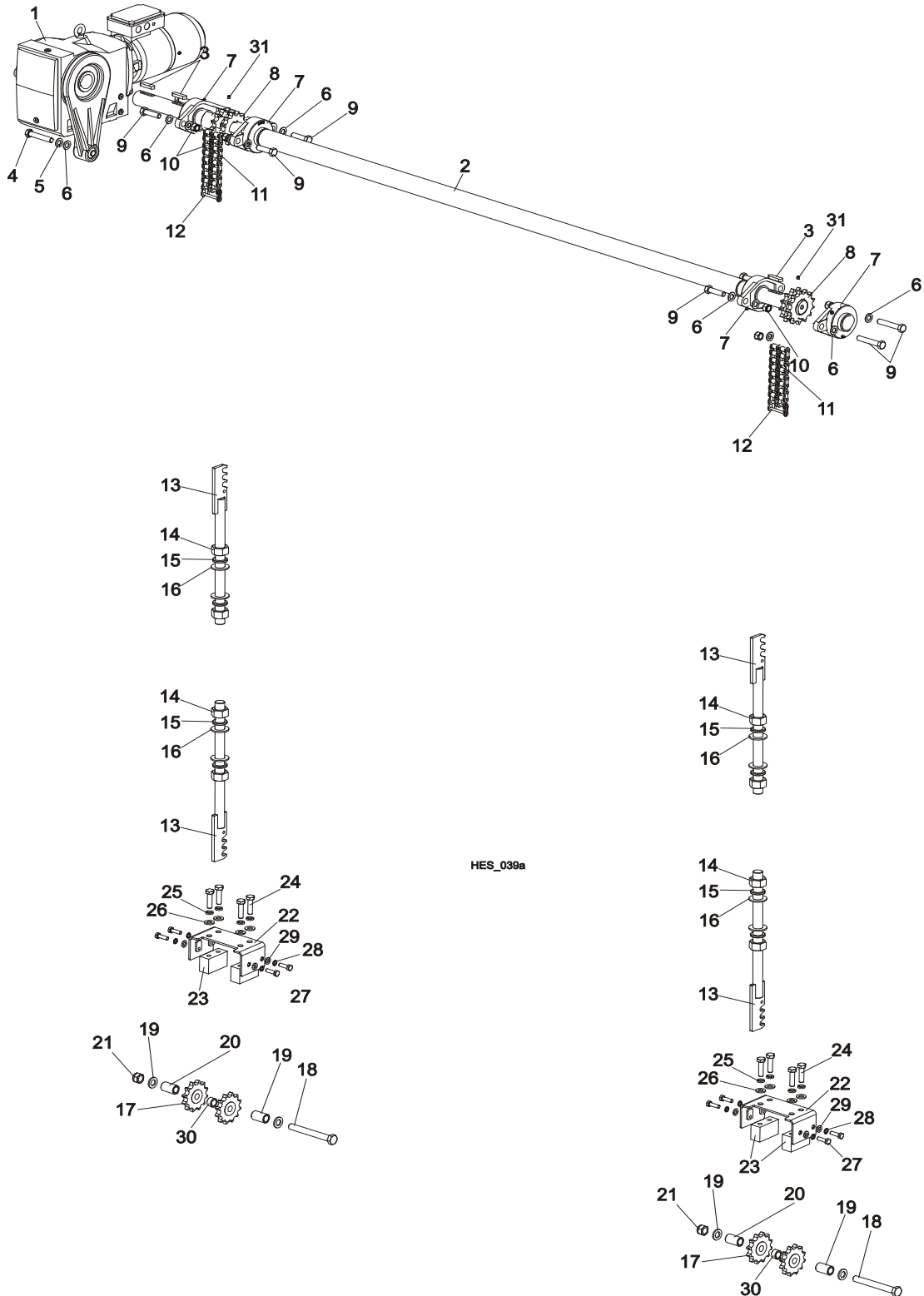

REF.	DESCRIPTION (◆ Indicates Parts Available In Assemblies Only)	PART #	QTY.
1	MOTOREDUCER, SK9032.1AZBDH-90S/4BRE20 TF	504150	1
	MOTOR SK 90S/4BRE20 TF	083725	1
	GEARBOX SK 9032.1AZBDH-OPEN	509032	4

2	SHAFT, WM1000 UP/DOWN FEED	500362-1	1	
3	KEY, A14x9x56 PN-M/85005-WM1000 PARALLEL	504601	3	
4	BOLT, M16x90 -8.8-HEX HEAD ZINC	F81006-17	1	
5	WASHER, 16,3 SPLIT LOCK ZINC	F81058-2	1	
6	WASHER, 17 FLAT ZINC	F81058-1	17	
7	BEARING ASSEMBLY, UCFL 210 CX-WM1000	098824	4	
8	SPROCKET, 13Z16Bfi50 ULMER T14968	506633-1	2	
9	BOLT, M16x60 8.8 HEX HEAD FULL THREAD ZINC	F81006-12	8	
10	NUT, M16-8-HEX NYLON ZINC LOCK	F81036-2	8	
	CHAIN, WM1000 UP/DOWN FEED COMPLETE	506642	2	
11	CHAIN, 16B-2 .207 ELEMENTS WM1000	506634	1	
12	LINK, 16B-2 T36073 ULMER 2-ROW	506635	1	
13	SCREW, 1" UP/DOWN CHAIN TENSION	506640-1	4	
14	NUT, M30 HEX ZINC	F81038-3	8	
15	WASHER, Z30.5 SPLIT LOCK ZINC	F81068-1	8	
16	WASHER, 31 FLAT ZINC	F81061-9	8	
17	SPROCKET, Z12 1"x17.02 W/BEARING	099746	2	
18	BOLT, M20x170-8.8 HEX HEAD ZINC	F81007-9	2	
19	WASHER, 21 FLAT ZINC	F81059-2	4	
20	BUSHING, $\phi 21$ X $\phi 30$ X 50 WM1000	502664-1	4	
21	NUT, M20-8-A-HEX NYLON ZINC LOCK	F81037-2	2	
	COVER, BOTTOM, UP/DOWN SPROCKET, COMPLETE	504791	1	
22	COVER, BOTTOM, UP/DOWN SPROCKET, PTD WM1000	504566-1	1	
23	BLOCK, GUARDING, UP/DOWN WM1000	504565	2	
24	BOLT M8X30-8.8	F81002-7	4	
25	WASHER 8,2 FE/ZN9	F81054-4	4	
26	WASHER, 8.4 FLAT ZINC	F81054-1	4	
27	BOLT, M6x20-8.8 HEX HEAD FULL THREAD ZIN	F81001-2	4	
28	WASHER, Z6.1 SPLIT LOCK ZINC	F81053-3	4	
29	WASHER, 6.4 FLAT ZINC	F81053-1	4	
30	SPACER FI20.5xFI30x15	100105-1	2	
31	SCREW M10X12-45H Fe/Zn5	F81003-46	2	

3.5 Operator Platform

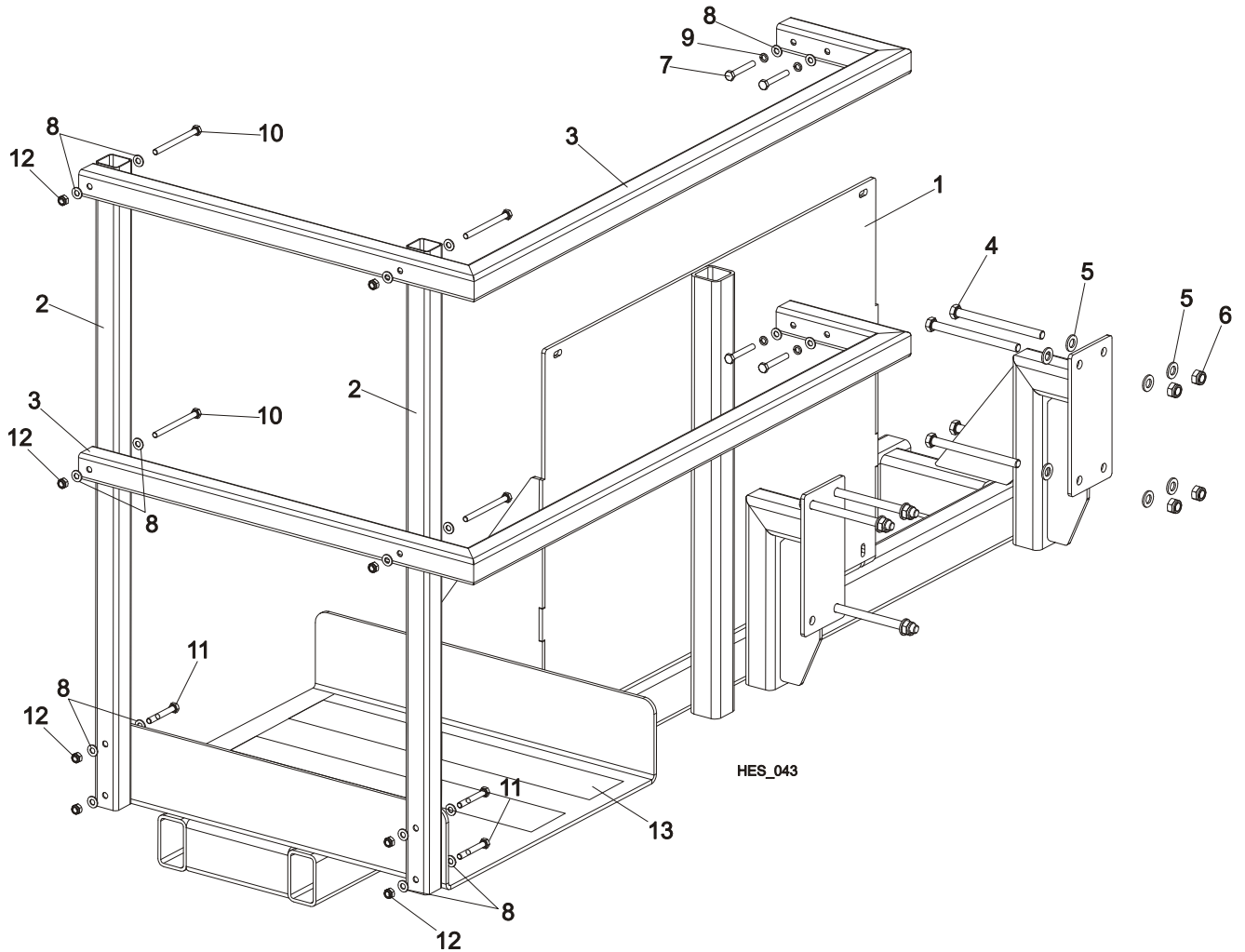

REF.	DESCRIPTION (◆ Indicates Parts Available In Assemblies Only)	PART #	QTY.	
1	OPERATOR PLATFORM WM1000	503125-1	1	
2	TUBE, WM1000 GUARD-RAIL POST VERTICAL	503239-1	2	
3	GUARD-RAIL, WM1000 OPERATOR	503244-1	2	
4	BOLT, M12x150-8.8-HEX HEAD ZINC	F81004-48	7	
5	WASHER, 13 FLAT ZINC	F81056-1	14	
6	NUT, M12-8 HEX NYLON ZINC LOCK	F81034-2	7	
7	BOLT, M8x55 8.8 HEX ZINC	F81002-8	4	
8	WASHER, 8,4-FLAT ZINC	F81054-1	19	
9	WASHER, 8,2 SPLIT LOCK ZINC	F81054-4	4	
10	BOLT, M8x100 -8.8- HEX HEAD ZINC	F81002-23	4	
11	BOLT, M8X60-8.8 HEX HEAD ZINC	F81002-54	2	
12	NUT, M8-8-B-FeZn5 HEX NYLON ZINC LOCK	F81032-2	8	
13	PAD, NON-SKID STEP, 6" WIDE	045149	2	

3.6 Power Cord Bracket

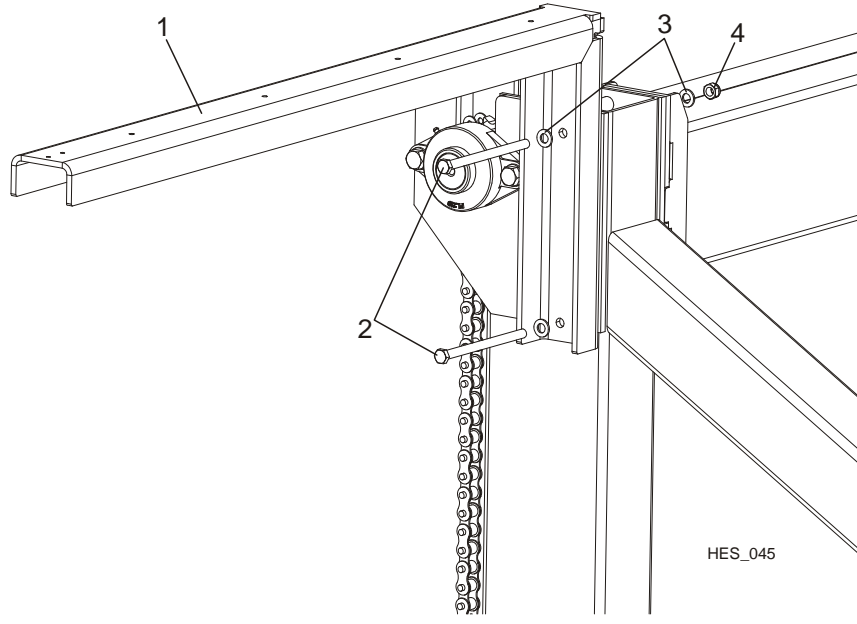

REF.	DESCRIPTION (◆ Indicates Parts Available In Assemblies Only)	PART #	QTY.	
1	BRACKET, WM1000 POWER CORD	504665-1	1	
2	BOLT, M12x180-8.8-HEX HEAD ZINC	F81004-49	2	
3	WASHER, 13 FLAT ZINC	F81056-1	4	
4	NUT, M12-8 HEX NYLON ZINC LOCK	F81034-2	2	

3.7 Electrical Wires Covers

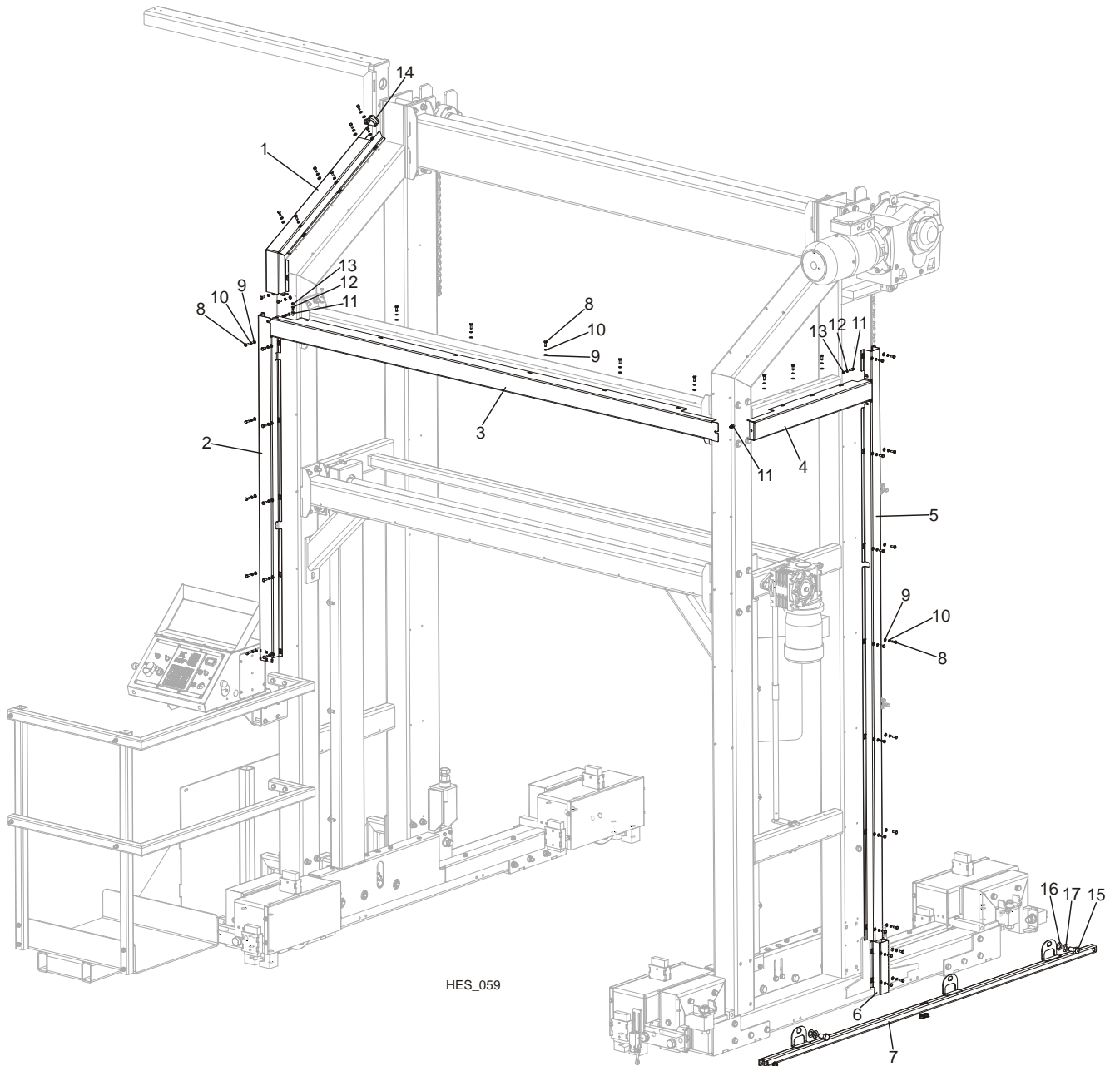

HES_059

REF.	DESCRIPTION (◆ Indicates Parts Available In Assemblies Only)	PART #	QTY.	
1	COVER, UPPER VERTICAL LEFT	505444-1	1	
2	COVER, SHORT HORIZONTAL LEFT	505211-1	1	
3	COVER, UPPER VERTICAL WIRE	505215-1	1	
4	COVER, SHORT HORIZONTAL RIGHT	505212-1	1	
5	COVER, LONG VERTICAL LEFT	505213-1	1	
6	COVER, SHORT VERTICAL LEFT	505395-1	1	
7	COVER, LOWER WIRE COMPLETE	505361	1	
8	BOLT, M6 x 16 8.8 HEX HEAD FULL THREAD ZINC	F81001-15	55	

9	WASHER, 6.4 FLAT ZINC	F81053-1	55	
10	WASHER, Z6.1 SPLIT LOCK ZINC	F81053-3	55	
11	SCREW, M5X15 3732 705 0115 RIVET	F81000-63	4	
12	WASHER, 5.3 FLAT ZINC	F81052-1	4	
13	NUT, M5-8-Fe/Zn5 DIN985	F81030-2	4	
14	GUARD, RSGU 1.30/20 W1 METAL-RUBBER	F81087-1	1	
15	BOLT, M16X30 8.8 HEX HEAD FULL THREAD ZINC	F81006-36	2	
16	WASHER, 17 FLAT ZINC	F81058-1	2	
17	WASHER,16.3 SPLIT LOCK ZINC	F81058-2	2	

3.8 Mast Limit Switch

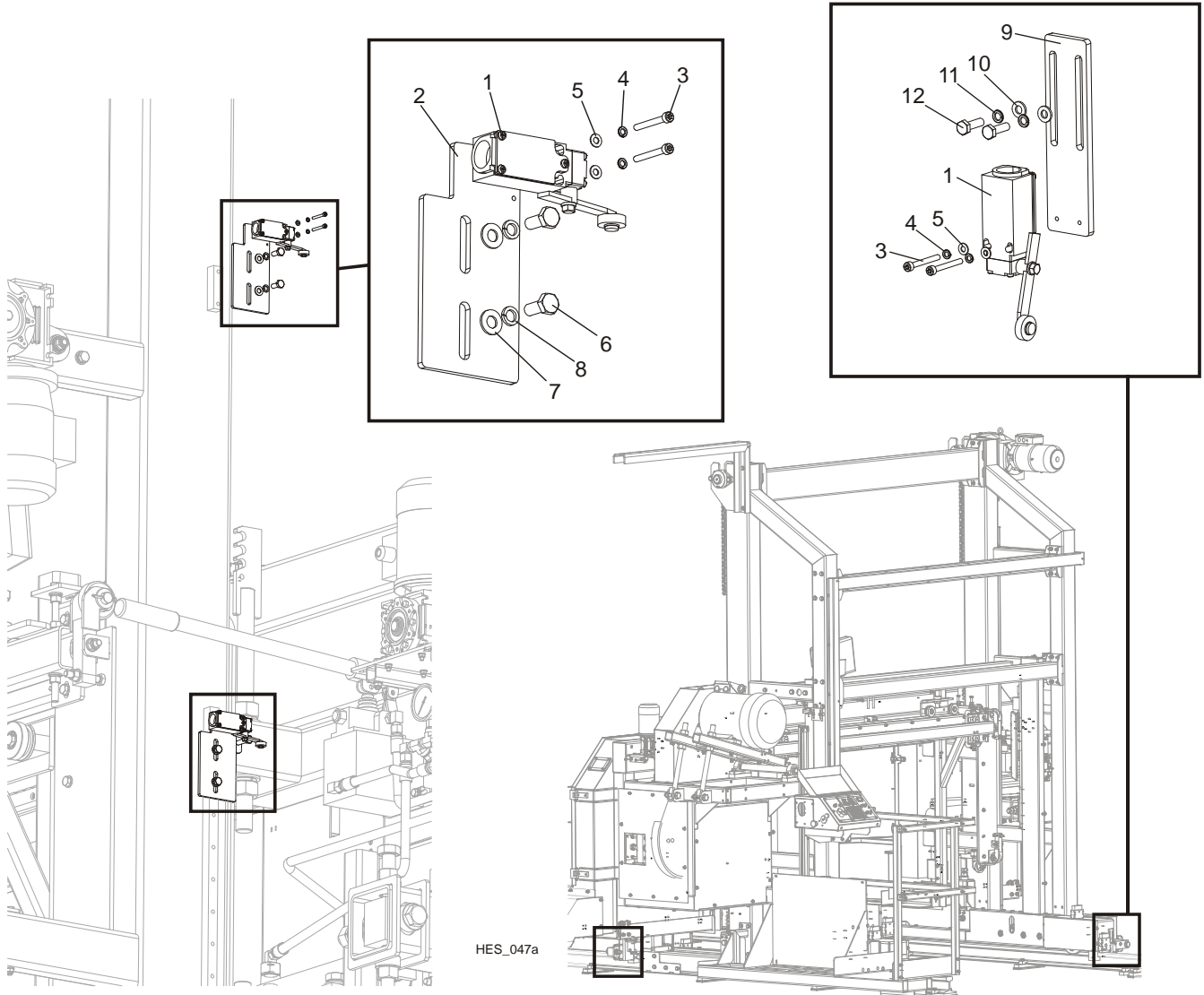

REF.	DESCRIPTION (◆ Indicates Parts Available In Assemblies Only)	PART #	QTY.
1	SWITCH, GLCB01A2B (HONEYWELL) LIMIT	086469	4
2	FLAT, WM1000 LIMIT SWITCH MOUNTING ZINC	504363-1	2
3	BOLT, M4x35 -8.8- SOCKET HEAD ZINC	F81011-34	8
4	WASHER, Z 4.1 SPLIT LOCK	F81051-1	8
5	WASHER, 4.3 FLAT ZINC	F81051-2	8
6	BOLT, M8x20-8.8-B-HEX HEAD FULL THREAD ZINC	F81002-4	4
7	WASHER, 8.4-FLAT ZINC	F81054-1	4
8	WASHER, 8.2 SPLIT LOCK ZINC	F81054-4	4
9	PLATE, WM1000/LT70/HR11 P/F LIMIT SWITCH MOUNT	505125-1	2
10	WASHER, 6.4 FLAT ZINC	F81053-1	2
11	WASHER, Z 6.1 SPLIT LOCK ZINC	F81053-3	2
12	BOLT, M6x20-8.8 HEX HEAD FULL THREAD ZINC	F81001-2	2

3.9 6 m & 15 m Tracks

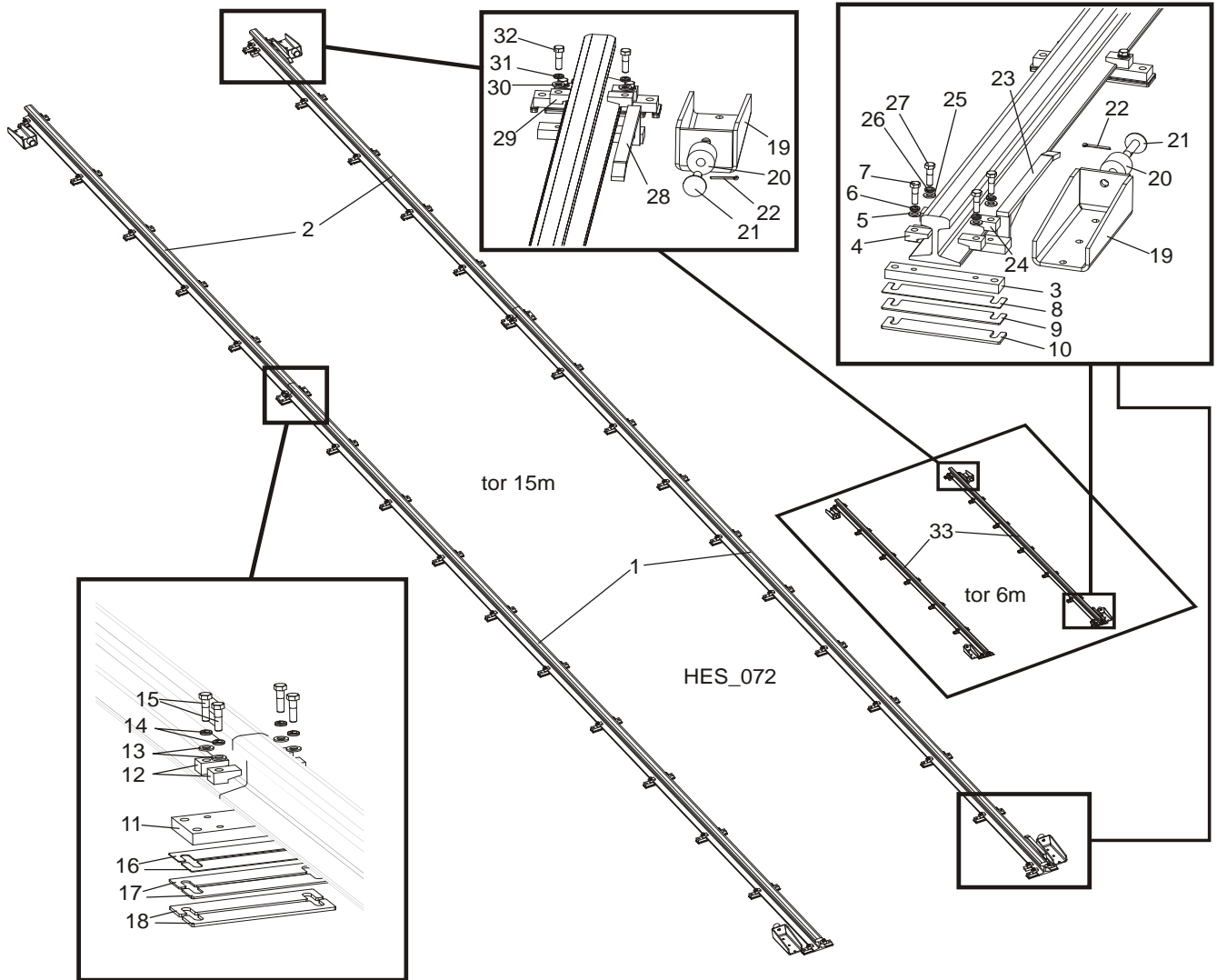

REF.	DESCRIPTION (◆ Indicates Parts Available In Assemblies Only)	PART #	QTY. 15m / 6m
	TRACK, WM1000 6M - COMPLETE	506620	1
	TRACK, 15M - COMPLETE	504795	1
1	RAIL, S40-10M DIN 5901	504797	2/0
2	RAIL, S40-6m DIN 5901	504798	2/0
	RAIL MOUNT ASSEMBLY - SINGLE	504793	30/14
3	BAR, RAIL MOUNT	502986-1	1
4	BLOCK, RAIL LOCKING - ZINC-PLATED	502970-1	2
5	WASHER, 13 FLAT ZINC	F81056-1	2
6	WASHER, Z12.2 SPLIT LOCK ZINC	F81056-2	2
7	BOLT, M12x40-8.8 HEX HEAD ZINC	F81004-1	2
8	WASHER, 1.5 MM SPACER, zinc	505122-1	1
9	WASHER, 3MM SPACER, zinc	505123-1	1
10	WASHER, 5MM SPACER, zinc	505124-1	1
	RAIL MOUNT ASSEMBLY - DOUBLE	504794	2/0
11	BAR, RAIL CONNECTION	502696-1	1
12	BLOCK, RAIL LOCKING - ZINC-PLATED	502970-1	4

13	WASHER, 13 FLAT ZINC	F81056-1	4	
14	WASHER, Z12.2 SPLIT LOCK ZINC	F81056-2	4	
15	BOLT, M12x40-8.8 HEX HEAD ZINC	F81004-1	4	
16	WASHER, 1.5 MM SPACER, zinc	505122-1	2	
17	WASHER, 3 MM SPACER, zinc	505123-1	2	
18	WASHER, 5 MM SPACER, zinc	505124-1	2	
	RUBBER BUMPER ASSEMBLY, WM1000	504796	4/4	
19	BRACKET WELDMENT, RUBBER BUMPER PTD	503245-1	1	
20	BUSHING, 11/16X2 1/8X1 3/4 RUBBER	P12165	1	
21	MOUNT WELDMENT, CARRIAGE STOP PTD	086182-1	1	
22	PIN, S-Zn 4x25 COTTER	F81043-2	1	
	PLATE, P/F LIMIT SWITCH ACTIVATOR PTD	505116	1/1	
23	PLATE, WM1000 P/F LIMIT SWITCH ACTIVATOR - RIGHT	505114-1	1	
24	BLOCK, RAIL LOCKING - ZINC-PLATED	502970-1	2	
25	WASHER, 13 FLAT ZINC	F81056-1	2	
26	WASHER, Z12.2 SPLIT LOCK ZINC	F81056-2	2	
27	BOLT, M12x40-8.8 HEX HEAD ZINC	F81004-1	2	
	PLATE, WM1000 P/F LIMIT SWITCH ACTIVATOR - LEFT	505117	1/1	
28	PLATE, WM1000 P/F LIMIT SWITCH ACTIVATOR - LEFT	505115-1	1	
29	BLOCK, RAIL LOCKING - ZINC-PLATED	502970-1	2	
30	WASHER, 13 FLAT ZINC	F81056-1	2	
31	WASHER, Z12.2 SPLIT LOCK ZINC	F81056-2	2	
32	BOLT, M12x40-8.8 HEX HEAD ZINC	F81004-1	2	
33	RAIL, S30-6m DIN 5901	506619	0/2	

3.10 Tracks: 10 m & 10 m Extension

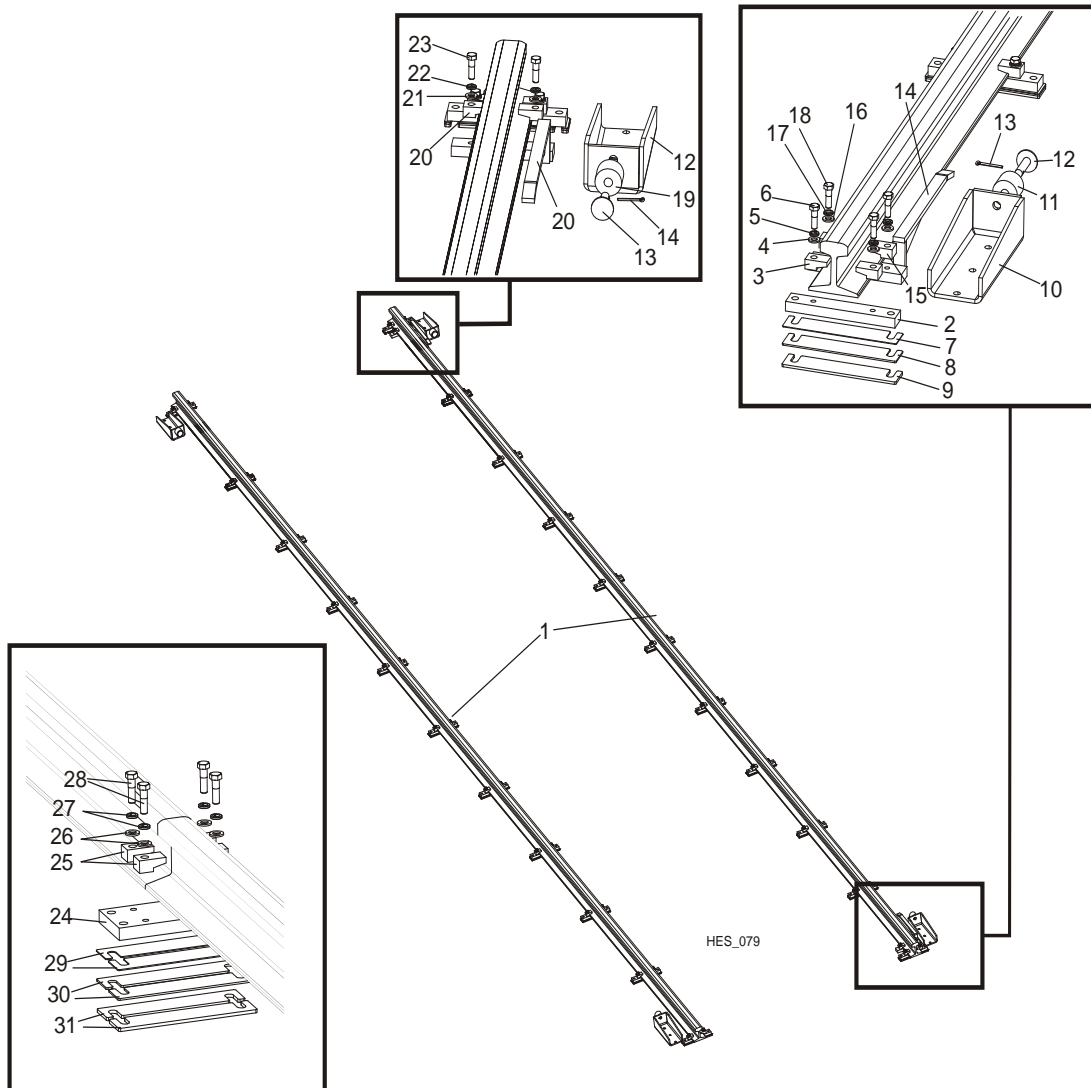

REF.	DESCRIPTION (◆ Indicates Parts Available In Assemblies Only)	PART #	QTY. 509750/ 509759
	TRACK, WM1000 10M - COMPLETE	509750	1
	TRACK, 10M - EXTENSION	509759	1
1	RAIL, S30-10M DIN 5901	504797	2/2
	RAIL MOUNT ASSEMBLY - SINGLE	504793	22/18
2	BAR, RAIL MOUNT	502986-1	1
3	BLOCK, RAIL LOCKING - ZINC-PLATED	502970-1	2
4	WASHER, 13 FLAT ZINC	F81056-1	2
5	WASHER, Z12.2 SPLIT LOCK ZINC	F81056-2	2
6	BOLT, M12x40-8.8 HEX HEAD ZINC	F81004-1	2
7	WASHER, 1.5 MM SPACER, zinc	505122-1	1
8	WASHER, 3MM SPACER, zinc	505123-1	1
9	WASHER, 5MM SPACER, zinc	505124-1	1
	RUBBER BUMPER ASSEMBLY, WM1000	504796	4/0
10	BRACKET WELDMENT, RUBBER BUMPER PTD	503245-1	1
11	BUSHING, 11/16X2 1/8X1 3/4 RUBBER	P12165	1

12	MOUNT WELDMENT, CARRIAGE STOP PTD	086182-1	1	
13	PIN, S-Zn 4x25 COTTER	F81043-2	1	
	PLATE, P/F LIMIT SWITCH ACTIVATOR PTD	505116	1/0	
14	PLATE, WM1000 P/F LIMIT SWITCH ACTIVATOR - RIGHT	505114-1	1	
15	BLOCK, RAIL LOCKING - ZINC-PLATED	502970-1	2	
16	WASHER, 13 FLAT ZINC	F81056-1	2	
17	WASHER, Z12.2 SPLIT LOCK ZINC	F81056-2	2	
18	BOLT, M12x40-8.8 HEX HEAD ZINC	F81004-1	2	
	PLATE, WM1000 P/F LIMIT SWITCH ACTIVATOR - LEFT	505117	1/0	
19	PLATE, WM1000 P/F LIMIT SWITCH ACTIVATOR - LEFT	505115-1	1	
20	BLOCK, RAIL LOCKING - ZINC-PLATED	502970-1	2	
21	WASHER, 13 FLAT ZINC	F81056-1	2	
22	WASHER, Z12.2 SPLIT LOCK ZINC	F81056-2	2	
23	BOLT, M12x40-8.8 HEX HEAD ZINC	F81004-1	2	
	RAIL MOUNT ASSEMBLY - DOUBLE	504794	0/2	
24	BAR, RAIL CONNECTION	502696-1	1	
25	BLOCK, RAIL LOCKING - ZINC-PLATED	502970-1	4	
26	WASHER, 13 FLAT ZINC	F81056-1	4	
27	WASHER, Z12.2 SPLIT LOCK ZINC	F81056-2	4	
28	BOLT, M12x40-8.8 HEX HEAD ZINC	F81004-1	4	
29	WASHER, 1.5 MM SPACER, zinc	505122-1	2	
30	WASHER, 3 MM SPACER, zinc	505123-1	2	
31	WASHER, 5 MM SPACER, zinc	505124-1	2	
	RESIN HIT-HY 200-A	509252	4/4	
	ANCHOR HIT-V-5,8.8M12X150	509293	90/90	
	TOOL, RESIN EXTRUSION HDM 500 CR/CB	509254	1/0	

3.11 33' & 66' Track Assembly (U.S. Only)

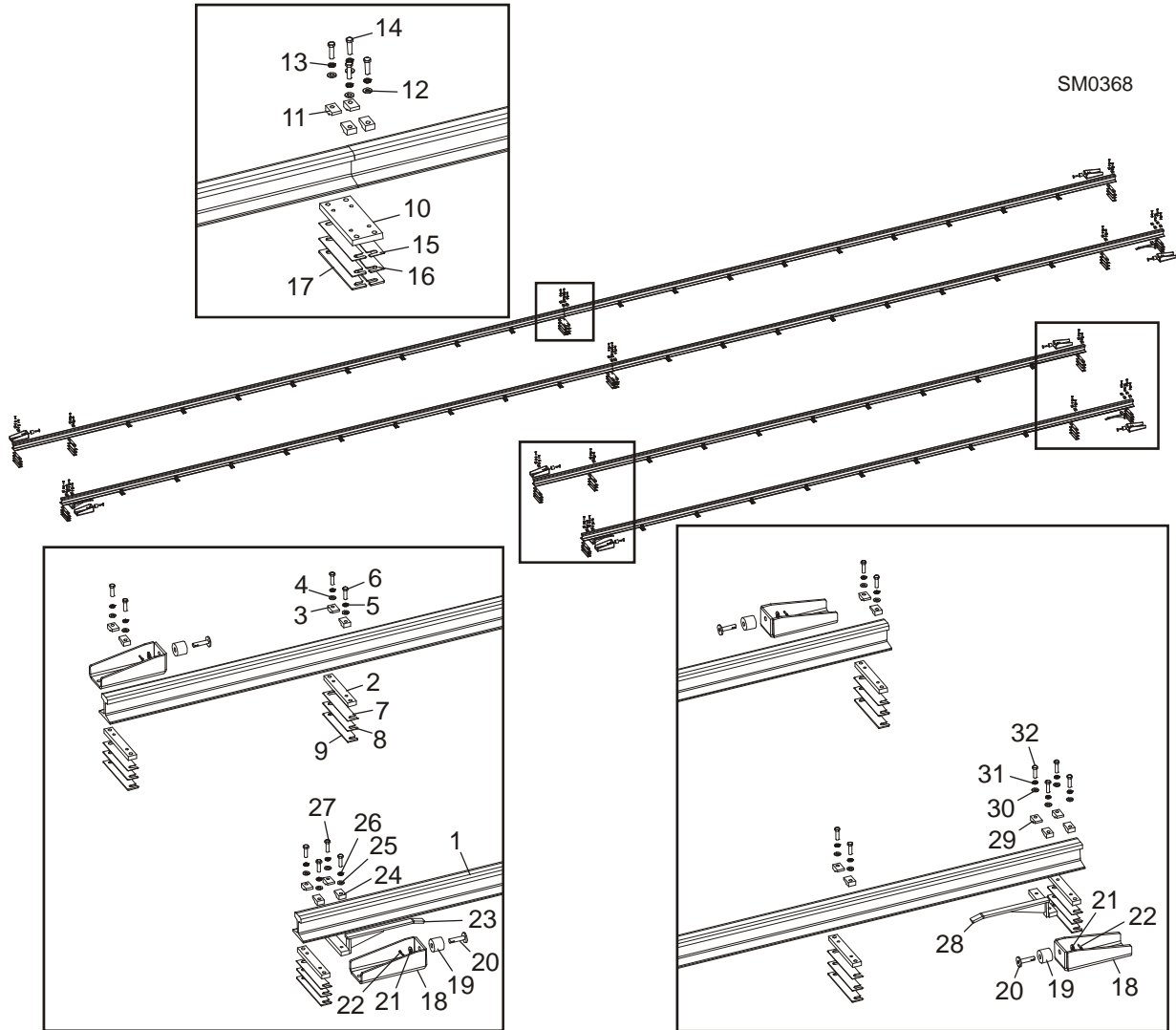

REF	DESCRIPTION (◆ Indicates Parts Available In Assemblies Only)	PART #	QTY.
	TRACK ASSEMBLY, WM1000 66' RAIL	065244-66	1
	TRACK ASSEMBLY, WM1000 33' RAIL	065244-33	1
1	Rail, 4-1/4 x 33' x 60 lbs. 6040	065229	4/2
	Bar Assembly, Rail Hold Down	065247	40/20
2	Bar, 1-1/2" Rail Foot Mount	065231	1
3	Block, Rail Toe Clamp	065230	2
4	Washer, 1/2" SAE Flat	F05011-2	2
5	Washer, 1/2" Split Lock	F05011-9	2
6	Bolt, 1/2-13 x 1 3/4" Hex Head Grade 5	F05008-88	2
7	Shim, 16Ga Rail Mount	065233	1
8	Shim, 1/8" Rail Mount	065234	1
9	Shim, 3/16" Rail Mount	065235	1
	Bar Assembly, Rail Hold Down Splice (66' Track Only)	065248	2
10	Bar, 3/4" x 4" x 9-1/2" Base Splice	065238	1
11	Block, Rail Toe Clamp	065230	4
12	Washer, 1/2" SAE Flat	F05011-2	4

13	Washer, 1/2" Split Lock	F05011-9	4	
14	Bolt, 1/2-13 x 1 3/4" Hex Head Grade 5	F05008-88	4	
15	Shim, 16Ga Rail Mount	065233	2	
16	Shim, 1/8" Rail Mount	065234	2	
17	Shim, 3/16" Rail Mount	065235	2	
18	Bracket, 3/8" WM1000 Head Stop	065245	4	
19	Bushing, 11/16" x 2 1/8" x 1 3/4" Rubber	P12165	4	
20	Stop Weldment, Carriage Ptd	W09293	4	
21	Washer, 5/8" SAE Flat	F05011-5	4	
22	Pin, 3/16" x 1" Cotter	F05012-21	4	
	Bar Assembly, Rail Pick Up Front	065249	1	
23	Slide Weldment, Rail Pick Up, Front	065243	1	
24	Block, Rail Toe Clamp	065230	2	
25	Washer, 1/2" SAE Flat	F05011-2	2	
26	Washer, 1/2" Split Lock	F05011-9	2	
27	Bolt, 1/2-13 x 1 3/4" Hex Head Grade 5	F05008-88	2	
	Bar Assembly, Rail Pick Up End	065251	1	
28	Slide Weldment, Rail Pick Up End	065250	1	
29	Block, Rail Toe Clamp	065230	2	
30	Washer, 1/2" SAE Flat	F05011-2	2	
31	Washer, 1/2" Split Lock	F05011-9	2	
32	Bolt, 1/2-13 x 1 3/4" Hex Head Grade 5	F05008-88	2	

SECTION 4 CONTROL BOX

4.1 Control Box Assembly

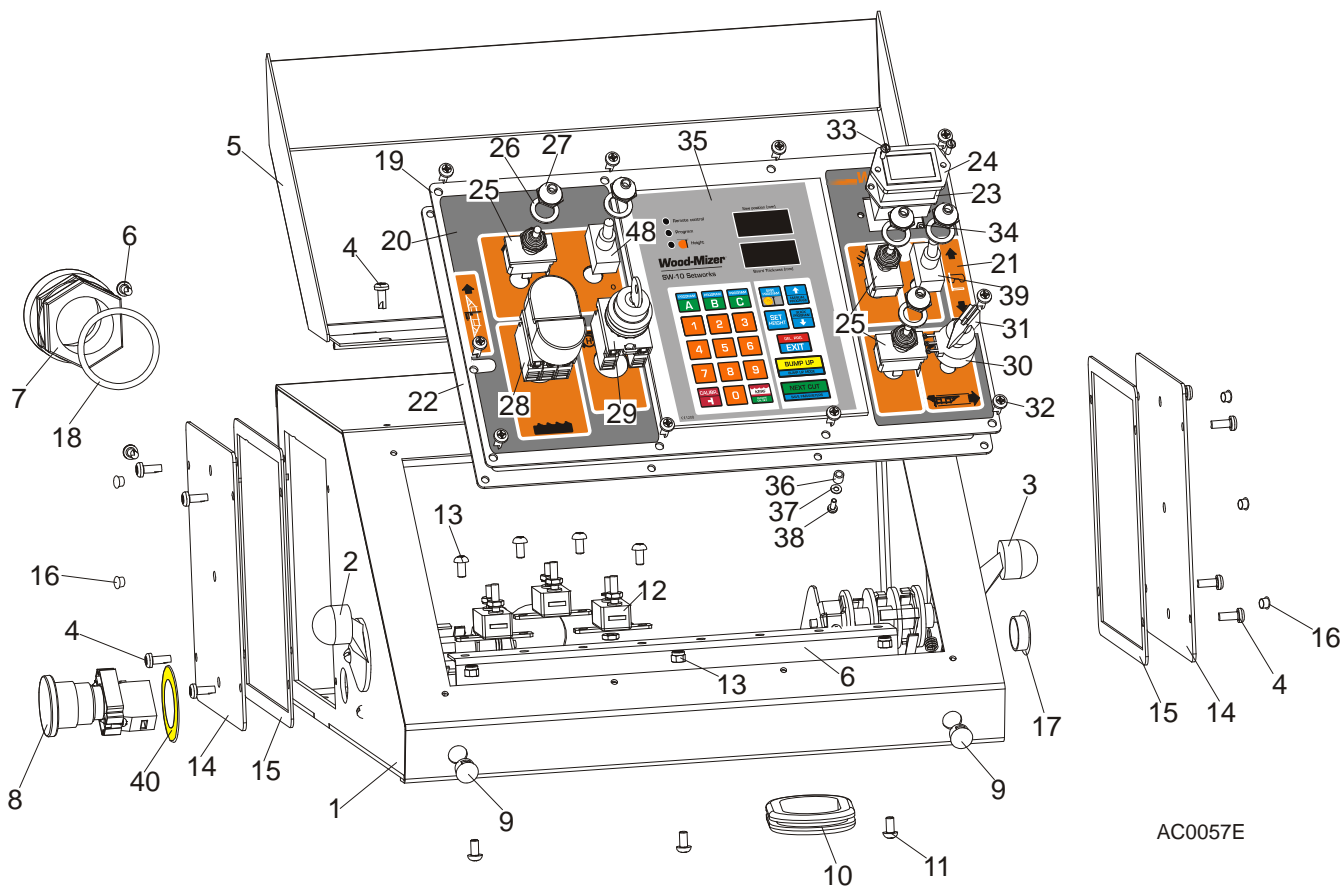

AC0057E

REF.	DESCRIPTION (◆ Indicates Parts Available In Assemblies Only)	PART #	QTY.
	CONTROL BOX ASSEMBLY	098690	1
1	Control Panel	099622-1	1
2	Switch, '92 EUROPower Feed	E20438	1
3	Switch, 1992 Up/Down	E20440	1
4	Bolt, #10-24 x 1/2 ph pan head type 23	F05015-17	12
5	Cover, LT20/40 Control Box Complete	097135-1	1
6	Rail, Circuit Breaker	015310	1
7	Connector, 1 1/4 Straight Metal Conduit	024402	1
8	Switch, XB4 BS542 Emergency	086556	1
9	Cap, 12.7 Heyman DP 500 #2643	086773	2
10	Grommet, Rubber	087065	1
11	Screw, H M5x10 8.8 Zinc	F81000-13	7
12	Breaker, 15A, Manual Reset	E20430	3
13	Nut, M5-8-Fe/Zn5 DIN 985	F81030-2	3
	Cover, Control Box Left	086700	2
14	Cover, Control Box Left	086699-1	1
15	Gasket, Control Box Left Cover	015274	1
16	Cap, SR1086 (dia 6,4)	099700	6

17	Cap, SR1086 (dia 22,2)	093544	1	
18	Ring, 1 1/4"LQTI Seal w/Retaining	015430	1	
	Plate, AC Control Box Front Complete	098689	1	
19	Plate, AC Control Box Front	100572-1	1	
20	Decal, AC Control Box Left	099594	1	
21	Decal, AC/DC Control Box Right	099596	1	
22	Gasket, Control Box	097132	1	
23	Gasket, Hour Meter	093346	1	
24	Meter, Hour	093166	1	
25	Switch	024000	3	
26	Washer, 1/2"x3/4"x 5/8" Nylon	P05251-1	5	
27	Boot, Toggle Switch	P02575	5	
28	Switch, 24V Start/Stop	090452	1	
	Membrane, M22-T-DD	090462	1	
29	Switch, M22 - 3-position Key	091361	1	
30	Potentiometer, 1k	E20519	1	
31	Knob, Speed Control	P06257	1	
32	Bolt, #10-24 x 1/2 Ph Pan Head Type 23	F05015-17	10	
33	Bolt, M3x12-8.8 Hex Head Full Thread Zinc	F81000-12	2	
34	Nut, M3-6-FHex Nylon Zinc Lock	F81028-2	2	
35	Controller, SW-10 Setwork	500628	1	
36	Bushing, dia. 4,2 length 6mm Spacer	R80671-4	6	
37	Washer, 3,2 Flat Zinc	F81050-2	6	
38	Screw, M3x8-4.8Zinc	F81000-83	6	
39	Switch, SPST On/Off TO11B Toggle	P03027	2	

4.2 Control Box Bracket

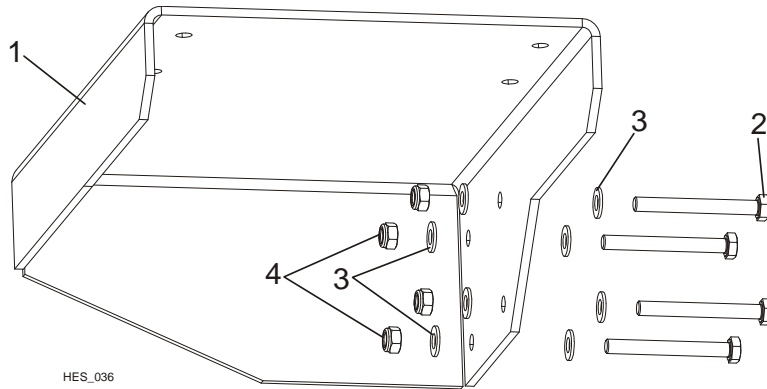

HES_036

REF.	DESCRIPTION (◆ Indicates Parts Available In Assemblies Only)	PART #	QTY.	
1	BRACKET, CONTROL BOX	502781-1	1	
2	BOLT, M8x70 8.8 HEX HEAD ZINC	F81002-71	4	
3	WASHER, 8,4-FLAT ZINC	F81054-1	8	
4	NUT, M8-8-B-HEX NYLON ZINC LOCK	F81032-2	4	

4.3 Switches

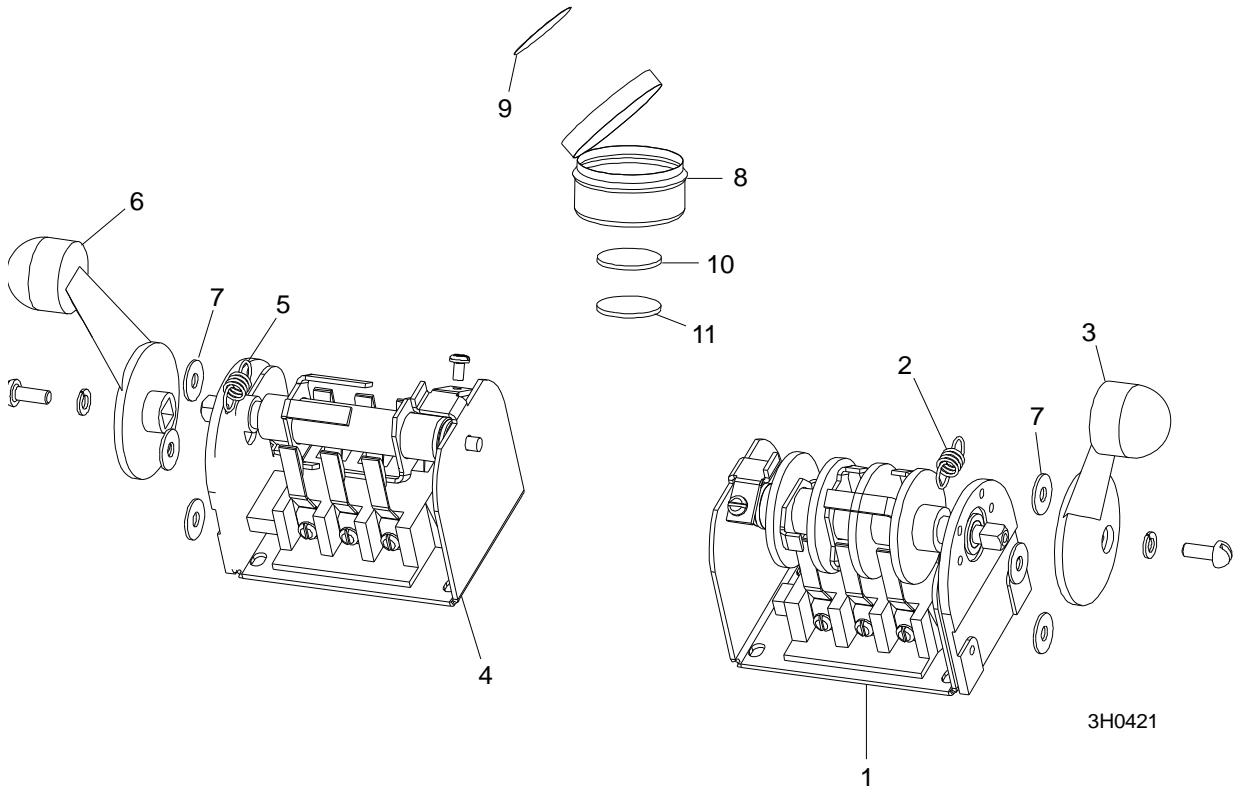

REF.	DESCRIPTION (◆ Indicates Parts Available In Assemblies Only)	PART #	QTY.	
	SWITCH, UP/DOWN	E20440	1	
1	Housing, Drum Switch	E20440-B	1	◆
2	Spring, Drum Switch	P12570	1	
3	Handle, Drum Switch w/Screw	P12500	1	
	SWITCH, POWER FEED	E20438	1	
4	Housing, Drum Switch	E20438-B	1	◆
5	Spring, Drum Switch	P12570	1	
6	Handle, Drum Switch w/Screw	P12500	1	
7	WASHER, #8 SAE FLAT ZINC	F05011-41	6	
	GREASE, DRUM SWITCH	A20463	1	
8	Cup, Grease Container	P20464	1	◆
9	Label, Grease Cup	P20467	1	
10	Velcro, Tab Loops	P20466	1	◆
11	Velcro, Tab Hook	P20465	1	◆
	Grease, Drum Switch	P20468	.011ml	◆

4.4 Circuit Breakers

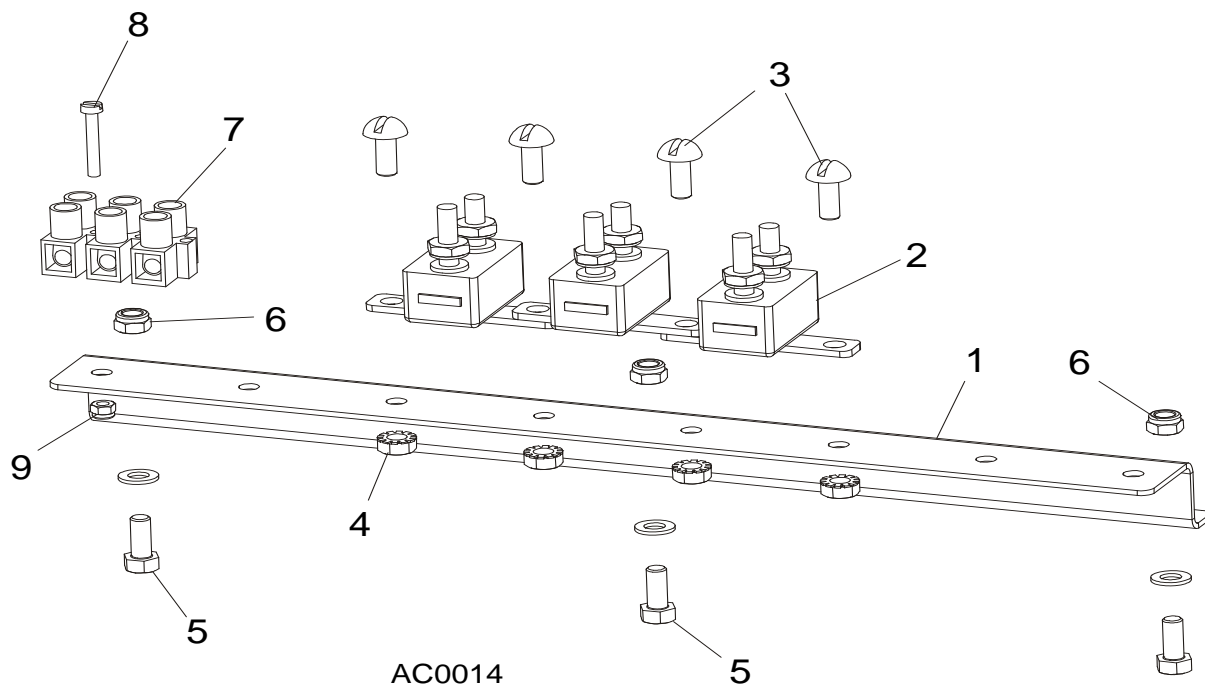

REF.	DESCRIPTION (◆ Indicates Parts Available In Assemblies Only)	PART #	QTY.
1	RAIL, CIRCUIT BREAKER	015310	1
2	BREAKER, 15A MANUAL RESET	E20430	3
3	SCREW, H M5X10 8.8 ZINC	F81000-13	4
4	NUT, M5-8- DIN 985 ZINC	F81030-2	4
5	BOLT, M5X12-5.8-HEX HEAD FULL THREAD ZINC	F81000-5	3
6	NUT, M5-8- DIN 985 ZINC	F81030-2	3
7	BLOCK, TERMINAL	F81086-1	1
8	SCREW, M3 X 20-5.8	F81000-8	1
9	NUT, M3-6 HEX NYLON ZINC LOCK	F81028-2	1