



user manual

Instrukcja obsługi | Руководство пользователя
Manuel de l'Utilisateur | Betriebsanweisung
Bruksanvisning | Manual del Usuario
Betjeningsvejledning | Gebruikershandleiding
Käyttöohjeet | Manual de utilizare | Bruksanvisning
Manuale d'uso | Příručka uživatele | Navodila
za uporabo

Retain for future use
Zachować do przyszłego użytku
Сохраните для последующего
использования
A conserver pour une utilisation future
Für zukünftige Benutzung aufbewahren
Behold for senere bruk
Säilytä nämä käyttöohjeet tulevaa tarvetta marten
Opbevar manualen til fremtidig brug
Bewaren voor gebruik in de toekomst
Conservare il presente manuale a l'uso futuro
Păstrați acest manual pentru utilizare viitoare
Conservar para futuras consultas
Behåll för framtida användning
Uchovejte pro další použití
Hranite za prihodnjo uporabo

Wood-Mizer®

Safety, Setup, Operation & Maintenance Manual

WM1000

rev.B1.01



Safety is our #1 concern! Read and understand all safety information and instructions before operating, setting up or maintaining this machine.

September 2010

Form #633

**This is the original language
for the manual**

Table of Contents

Section-Page

SECTION 1	INTRODUCTION	1-1
1.1	Machine Description	1-1
1.2	Machine and Site Preparation.....	1-2
1.3	If You Need To Order Parts	1-2
1.4	If You Need Service	1-3
SECTION 2	SAFETY	2-1
2.1	Blade Handling	2-2
2.2	Sawmill Setup.....	2-3
2.3	Sawmill Operation.....	2-4
2.4	Sawmill Maintenance	2-6
SECTION 3	SETUP & OPERATION	3-1
3.1	Sawmill Setup.....	3-1
3.2	Replacing the Blade.....	3-4
3.3	Tensioning the Blade	3-5
3.4	Tracking the Blade	3-6
3.5	Starting the Motor.....	3-7
3.6	Loading and Clamping Logs	3-9
3.7	Up/Down Operation	3-10
3.8	Blade Guides Setting	3-11
3.9	Power Feed Operation	3-12
3.10	Cutting the Log.....	3-14
3.11	Blade Height Scale	3-15
3.12	Lube System Operation	3-17
SECTION 4	MAINTENANCE	4-1
4.1	Wear Life.....	4-1
4.2	Blade Guides	4-2
	<i>Steel Guide Blocks</i>	
4.3	Sawdust Removal	4-3
4.4	Carriage Track, Wiper & Scrapers	4-4
4.5	Vertical Mast Rails	4-6
4.6	Drum Switches	4-6
4.7	Miscellaneous	4-6
4.8	Drive Belt Adjustment.....	4-7
4.9	Up/Down System.....	4-8
4.10	Power Feed	4-9
4.11	Blade Guide Chain Tension.....	4-11
4.12	Safety Devices Inspection	4-12

Table of Contents

Section-Page

SECTION 5	SAWMILL ALIGNMENT	5-1
5.1	Alignment Procedure.....5-1 <i>Blade Installation</i> <i>Saw Head Tilt</i> <i>Blade Wheels Adjustment</i> <i>Blade Guides</i>	
SECTION 6	SAWMILL SPECIFICATIONS	6-1
6.1	Belt Sizes6-1	
6.2	Blade Specification.....6-1	
6.3	Cutting Capacity6-1	
6.4	Motor Specifications6-2	
6.5	Noise Level.....6-2	
6.6	Overall Dimensions6-3	
6.7	Chains6-3	
6.8	Sawdust Extractor Specifications6-4	
6.9	Lube System Specifications6-4	
SECTION 7	HYDRAULIC DIAGRAMS (OPTIONAL EQUIPPMENT)	7-1
SECTION 8	ELECTRICAL DIAGRAMS	8-1
8.1	Electrical Diagram, WM1000EH30S8-2	
8.2	Electrical Component List, WM1000EH30S8-4	
8.3	Electrical Diagram, WM1000EH40S8-6	
8.4	Electrical Component List, WM1000EH40S8-8	
8.5	Electrical Diagram, WM1000EH50S8-10	
8.6	Electrical Component List, WM1000EH50S8-12	
8.7	Electrical Diagram, WM1000EC308-14	
8.8	Electrical Component List, WM1000EC308-16	
8.9	Electrical Diagram, WM1000EC508-18	
8.10	Electrical Component List, WM1000EC508-20	

SECTION 1 INTRODUCTION

Thank you for choosing Wood-Mizer wood processing equipment!

Wood-Mizer is committed to providing you with the latest technology, best quality and strongest customer service available on the market today. We continually evaluate our customers' needs to ensure we're meeting current wood-processing demands. Your comments and suggestions are welcome.

The present documentation contains information that should be used when preparing the machine for operation, working with it and when servicing or repairing it, as well.

1.1 Machine Description

The WM1000 sawmill is intended for sawing wood only. The sawmill must not be used for any other purposes such as cutting ice, metal or any other materials.

Using the machine correctly, you will obtain a material of the highest quality and high degree of accuracy.

The WM1000 sawmill should be operated only by an adult who has read and understood the entire operator's manual.

The machine is built to be durable and easy to operate and maintain.

1.2 Machine and Site Preparation

The sawmill is delivered and installed at customer's premises by the Wood-Mizer Customer Service.

The major components of the WM1000 sawmill are shown in the figure below.

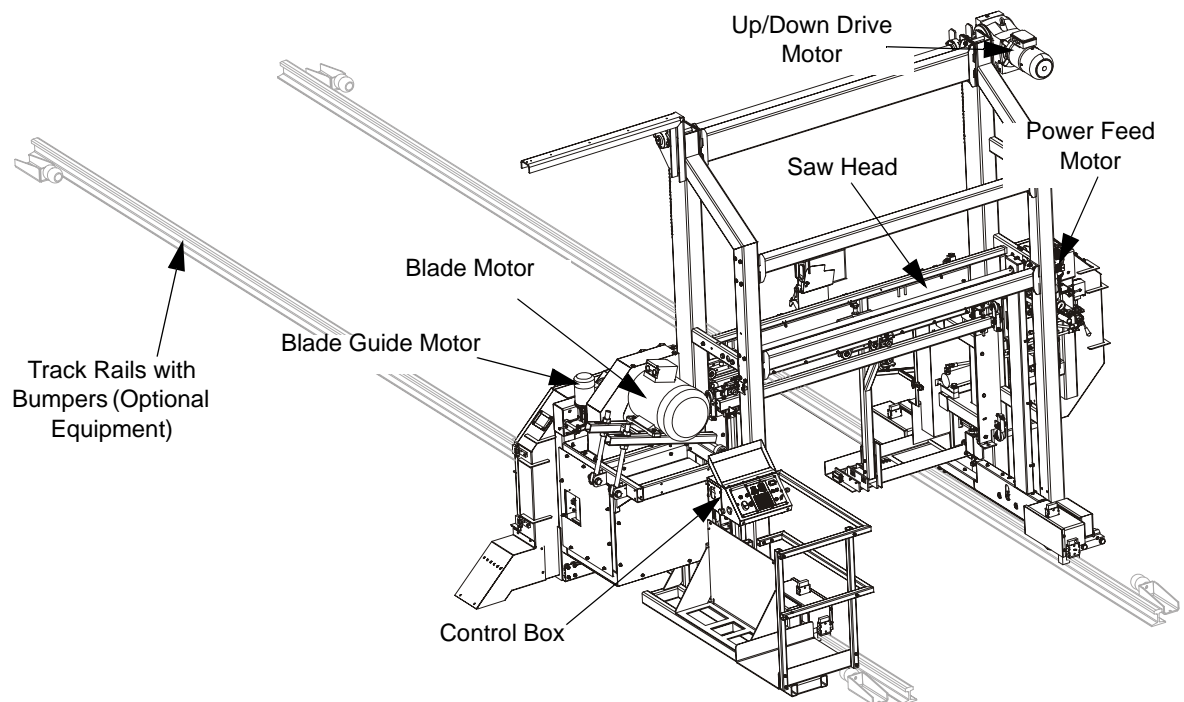

FIG. 1-0

1.3 If You Need To Order Parts

From Europe call your local distributor or our European Headquarters and Manufacturing Facility in Kolo, Nagórna 114 St, Poland at +48-63-2626000. From the continental U.S., call our toll-free Parts hotline at **1-800-525-8100**. Please have the machine identification number and your customer number ready when you call. Wood-Mizer will accept these methods of payment:

- Visa, Mastercard, or Discover
- COD
- Prepayment
- Net 15 (with approved credit)

Be aware that shipping and handling charges may apply. Handling charges are based on size and quantity of order. In most cases, items will ship on the day they are ordered. Second Day and Next Day shipping are available at additional cost.

1

INTRODUCTION

If You Need Service

From the continental U.S., call our toll-free Parts hotline at **1-800-525-8100**.

1.4 If You Need Service

From Europe call your local distributor or our European Headquarters and Manufacturing Facility in Kolo, Nagórna 114 St, Poland at **+48-63-2626000**. From the continental U.S., call our U.S. Headquarter 8180 West 10th St. Indianapolis, IN 46214, toll-free at **1-800-525-8100**. Ask to speak with a Customer Service Representative. Please have your machine identification number and your customer number ready when you call. The Service Representative can help you with questions about the operation and maintenance of your sawmill. He also can schedule you for a service call.

Office Hours:

Country	Monday - Friday	Saturday	Sunday
Poland	7 a.m.- 3 p.m.	Closed	Closed
US	8 a.m.- 5 p.m.	8 a.m.- 5 p.m	Closed

SECTION 2 SAFETY



This symbol calls your attention to instructions concerning your personal safety. Be sure to observe and follow these instructions. This symbol accompanies a signal word. The word **DANGER** indicates an imminently hazardous situation which, if not avoided, will result in death or serious injury. **WARNING!** suggests a potentially hazardous situation which, if not avoided, could result in death or serious injury. **CAUTION** refers to potentially hazardous situations which, if not avoided, may result in minor or moderate injury to persons or equipment. Read all safety instructions before operating this machine and observe all safety warnings!



Warning stripes are placed on areas where a single decal would be insufficient. To avoid serious injury, keep out of the path of any equipment marked with warning stripes.

Read all safety instructions before operating this sawmill and observe them during operation of the machine! Also read any additional manufacturer's manuals and observe any applicable safety instructions including dangers, warnings, and cautions.

Always be sure that all safety decals placed on the machine are clean and readable. Replace immediately all damaged safety decals to prevent personal injury or damage to the equipment. Contact your local Wood-Mizer dealer, or call Wood-Mizer Customer Service Department to order more decals.

IMPORTANT! It is always the owner's responsibility to comply with all applicable federal, state and local laws, rules and regulations regarding the ownership, operation and towing of your Wood-Mizer sawmill. All Wood-Mizer mill owners are encouraged to become thoroughly familiar with these applicable laws and comply with them fully while using or towing the mill.

Always properly dispose of all sawing by-products, including sawdust and other debris, coolant, oil, fuel, oil filters and fuel filters.

Safety instructions are listed in this section by the following operations:

- Blade Handling,
- Sawmill Setup,
- Sawmill Operation,
- Sawmill Maintenance.

2.1 Blade Handling



DANGER! Always disengage the blade and shut off the sawmill motor before changing the blade. Failure to do so may result in serious injury.



WARNING! Always wear gloves and eye protection when handling bandsaw blades. Changing blades is safest when done by one person! Keep all other persons away from area when coiling, carrying or changing a blade. Failure to do so may result in serious injury.

2.2 Sawmill Setup



WARNING! Securely fasten rails of a sawmill to the floor before operating the sawmill. Failure to do so may result in serious injury or death.

WARNING! The sawmill should be set up on firm, level ground and must be fastened to the ground.



CAUTION! Changes in temperature could cause blade tension changes. Release the blade tension when the sawmill is not in use.

2.3 Sawmill Operation



IMPORTANT! The sawmill is intended for sawing wood only. See Section [6.3 Cutting Capacity](#) for log size capacities of the machine.

IMPORTANT! The sawmill's operator should get training in operation and adjustment of the machine.



DANGER! Make sure all guards and covers are in place and secured before operating. Failure to do so may result in serious injury.

Be sure the blade housing and pulley covers are in place and secured, and the safety switches located on them are engaged. Use the rubber latches to fasten the blade housing covers shut.

DANGER! Always keep hands away from moving bandsaw blade. Failure to do so may result in serious injury.

DANGER! Keep all persons out of the path of moving equipment and logs when operating the sawmill or loading and turning logs. Failure to do so may result in serious injury.

DANGER! Maintain a clean and clear path for all necessary movement around the mill and lumber stacking areas. Failure to do so may result in serious injury.

DANGER! Always be sure all persons are out of the path of the blade before starting the motor. Failure to do so may result in serious injury.

WARNING! When operating or servicing the machine, always wear eye, ear and foot protection as well as safety clothing. Failure to do so may result in serious injury.



WARNING! Secure all loose clothing and jewelry before operating the sawmill. Failure to do so may result in serious injury or death.

WARNING! Always make sure a log is clamped securely before sawing. Failure to do so may result in serious injury or death.

WARNING! Use ONLY oil specified in Section [6.9 Lube System Specifications](#) with the blade lube system. Never use flammable fuels or liquids! If these types of liquids are necessary to clean the blade, remove it and clean with a rag. Failure to do so may result in serious injury or death. When cutting in freezing temperatures, use an anti-freeze, non-flammable additive.



CAUTION! Make sure the log handling accessories are below bed level before loading a log onto the bed. Failure to do so may result in machine damage or cause misalignment.

CAUTION! Before loading a log, make sure the saw head is moved far enough so the log does not hit it. Failure to do so may result in sawmill damage.

CAUTION! Do not try to force the saw head beyond its upper and lower travel limits. Damage to the up/down system may result.



CAUTION! Never clean the blade or the blade wheels with a brush or a scraper during sawmill operation.

CAUTION! Before installation of the blade, inspect it for damage and cracks. Use only properly sharpened blades. Always handle the blade with extreme caution. Use suitable carrier equipment for transporting blades.

CAUTION! Always wear gloves when handling the blade. Never grab the blade with bare hands!

CAUTION! If the blade breaks during sawmill operation, the blade motor will be stopped automatically. Wait until both wheels have come to a complete stop before you open the blade housing covers.

CAUTION! Be sure to stop the blade when returning the saw head. This will not only prevent the blade from being pulled off and ruined by a wood sliver, but also will increase the life of the blade.

CAUTION! The sawmill's work-stand should be equipped with a 4 kg or bigger dry powder extinguisher.

CAUTION! If at any time you need to immediately stop the blade motor, press the emergency stop button located on the control box.

CAUTION! The sawmill should be operated with a sawdust extraction system only.

CAUTION! When working in dusty conditions, use a protective dust mask.

2.4 Sawmill Maintenance



WARNING! Always secure the saw head with a chain or a brace before adjusting the up/down chain. The saw head may fall, causing severe injury or death.

WARNING! Always secure the saw head with a chain or a brace before adjusting the saw head guide rollers. The cutting head may fall, causing severe injury or death.

CAUTION! Do not use chain lube. It causes sawdust buildup in chain links.



CAUTION! Due to variations in the vertical mast, the guide roller spacing may vary throughout the travel of the saw head. Check the guide roller spacing at the top and bottom ends of the mast only. Rollers adjusted too tight will cause premature up/down motor failure.



DANGER! Always disconnect and lock out power supply before performing any maintenance work, cleaning or servicing the sawmill!

See Table 2-1 Pictographic safety decals placed on the WM1000 sawmill are shown in the table below.

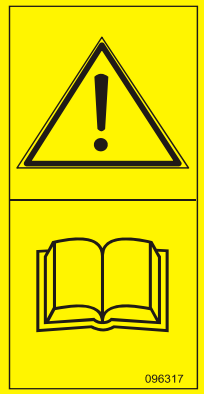
TABLE 2-1

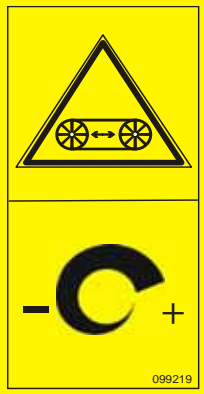
Decal View	Decal No.	Description
	096317	CAUTION! Read thoroughly the manual before operating the machine. Observe all safety instructions and rules when operating the sawmill.
	099220	CAUTION! Close all guards and covers before starting the sawmill.
	099219	Blade tension. Turning the bolt clockwise will increase the blade tension, and turning the bolt counterclockwise will decrease the tension.

2 Safety

Sawmill Maintenance

TABLE 2-1





 <p>099221</p>	<p>099221</p>	<p>CAUTION! Keep all other persons at a safe distance from work area when operating the machine.</p>
 <p>098176</p>	<p>098176</p>	<p>CAUTION! Keep a safe distance from the debarker blade!</p>
 <p>096316</p>	<p>096316</p>	<p>CAUTION! Do not open or close the electric box when the switch is not in the "0" position.</p>

TABLE 2-1

 <p style="text-align: right; font-size: small;">096319</p>	<p>096319</p>	<p>CAUTION! Disconnect power supply before opening the box.</p>
 <p style="text-align: right; font-size: small;">099222</p>	<p>099222</p>	<p>CAUTION! Sawdust chute. Protect eyes!</p>
 <p style="text-align: right; font-size: small;">096321</p>	<p>096321</p>	<p>Blade movement direction</p>
	<p>S12004G</p>	<p>CAUTION! Always wear safety goggles when operating the sawmill!</p>

2 Safety
Sawmill Maintenance

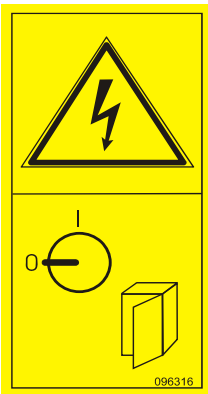
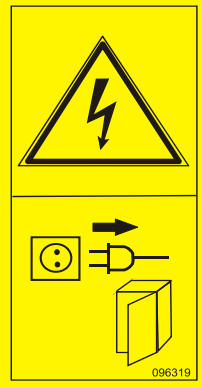
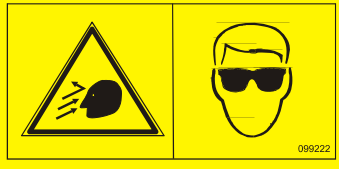
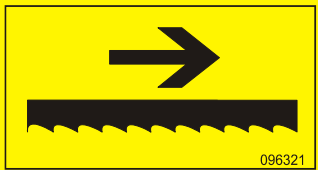
TABLE 2-1





	S12005G	CAUTION! Always wear protective ear muffs when operating the sawmill!
	501465	CAUTION! Always wear safety boots when operating the sawmill!
	501467	Lubrication point
	P11789	Aligning the blade on the wheels
	P85070	CE safety certification

TABLE 2-1

	<p>099401</p>	<p>Russian safety certification</p>
	<p>S20097F</p>	<p>Motor rotation direction - 1465 r.p.m.</p>

SECTION 3 SETUP & OPERATION

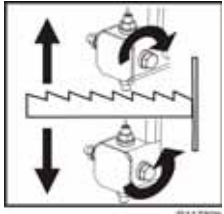
3.1 Sawmill Setup

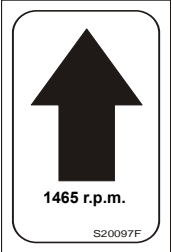

IMPORTANT! Before starting to use the sawmill you have to meet the following conditions:

- Set up the machine on firm and level ground.
- The sawmill should be operated with a sawdust extraction system only.
- The sawmill should be operated under roof only.
- The sawmill should be operated in temperature range from -15°C do 40° (5°F to 104°F) only.
- The illumination at the operator's position should be at least 300lx¹.
- The sawmill operator's position is shown below.

1.. The light source can not cause stroboscopic effect.

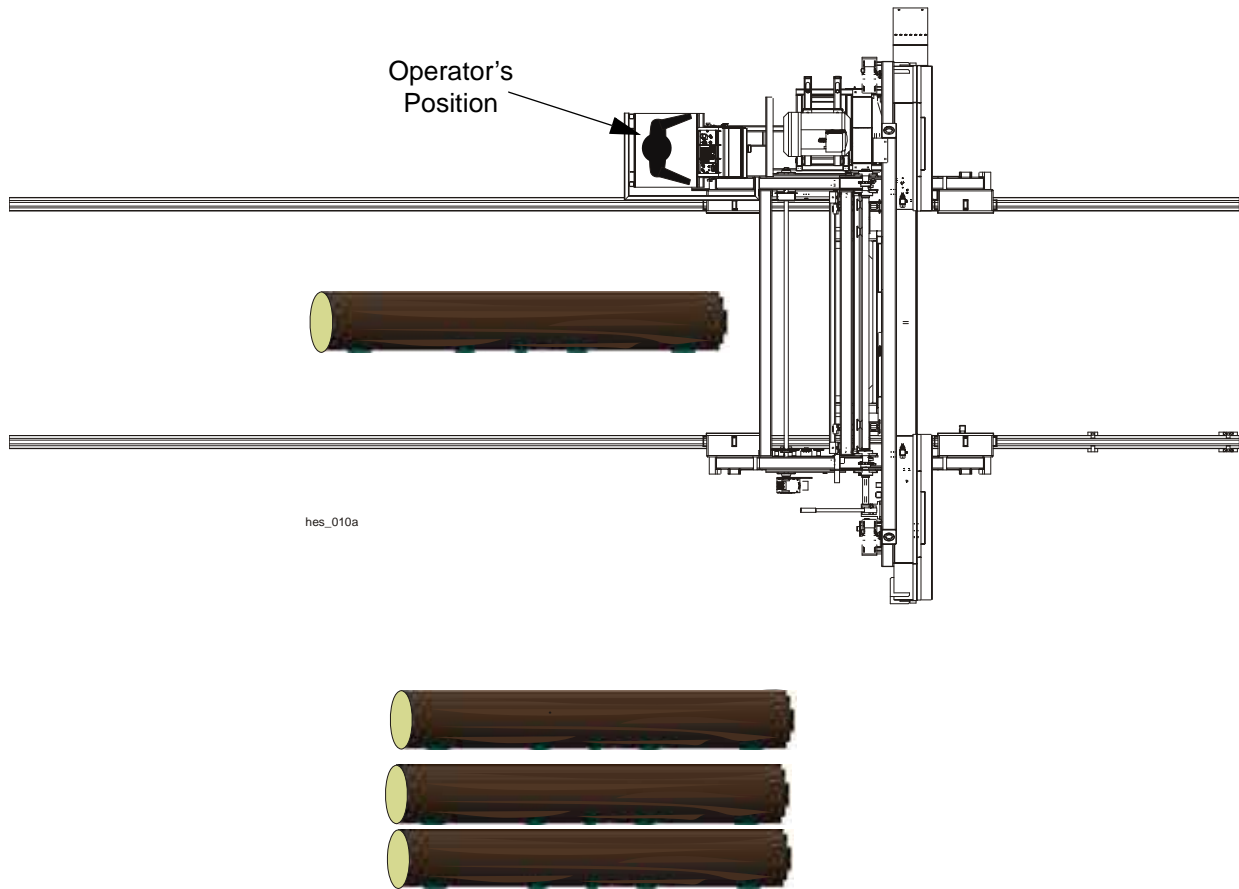

- Have a qualified electrician install the power supply (according to EN 60204 Standard). The power supply must meet the specifications given in the table below.

3-Phase Volts	Fuse Disconnect	Suggested Wire Size
EH30, EC30 22 KW 400 VAC 460 VAC	50 A	16 mm ² to 15m in length 5 AWG to 49 ft in length
EH40, EC40 30 KW 400 VAC 460 VAC	70 A	16 mm ² to 15m in length 5 AWG to 49 ft in length
EH50, EC50 37 KW 400 VAC 460 VAC	80 A	16 mm ² to 15m in length 5 AWG to 49 ft in length

TABLE 3-1



IMPORTANT! When starting the machine for the first time,

3

Setup & Operation

Sawmill Setup

check that main motor rotation direction is as indicated by the arrow located on the motor body. If the rotation direction is incorrect, invert the phases in the phase inverter located in the power socket. Setting the phases in the phase inverter correctly will ensure correct rotation directions of all sawmill motors.



DANGER! It is recommended that a 30mA Ground Fault Interrupter (GFI) be used.

Set up the sawmill on firm and level footing. Fasten the machine to the floor to prevent any movement. It is highly recommended that cement pads with 21mm (0.827") diameter anchor bolts be made under the track rails and the bed (if equipped). The cement pad should be rated to support 40 T/m² (8192 pound/foot).



WARNING! Fasten the sawmill to the floor before operating.

The machine can be lifted with a forklift or a winch only. The forklift must be rated for at least 4 T (8818 lb.). The sawmill head is equipped with lifting brackets. Attach the winch hook to the brackets shown in the figure below.

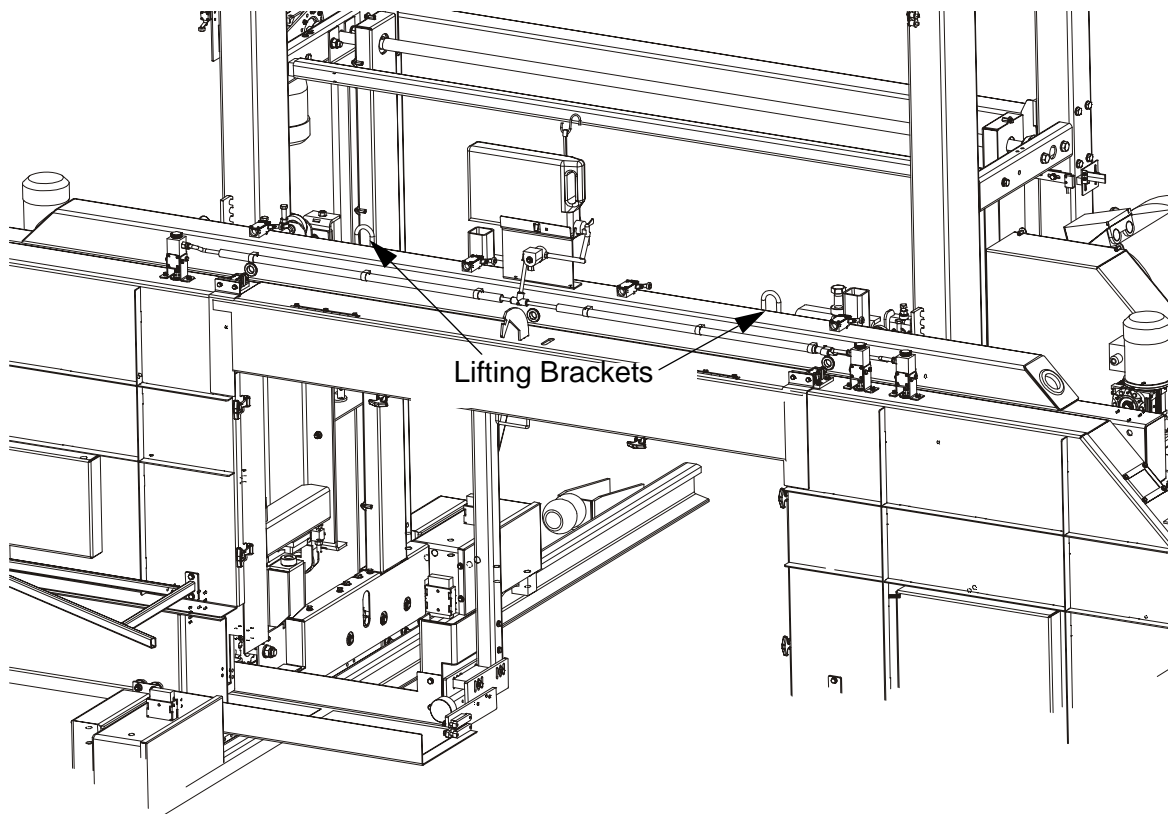

FIG. 3-1

3.2 Replacing the Blade



DANGER! Always shut off the sawmill motor before changing the blade. Failure to do so may result in serious injury.



WARNING! Always wear gloves and eye protection whenever handling a bandsaw blade. Changing blades is safest when done by one person! Keep all other persons away from work area when changing blades. Failure to do so may result in serious injury.

Move the right blade guide arm out.

Open the blade housing covers. Release the blade tension ([See Section 3.3](#)) until the wheel is pulled in and the blade is lying loose in the blade housing. Carefully remove the blade from the blade housing.

Install the blade so it is lying around the wheels. When installing the blade, make sure the teeth are pointing the correct direction. The teeth should be pointing toward the operator side of the sawmill when you are looking at the blade below the blade guides, as shown on the label located on the blade housing.

Position 2" wide blades on the wheels so the gullet is 5mm (0.196 ") out from the front edge of the wheel.

Close the blade housing. Next, use the blade tension handle to tension the blade correctly.



CAUTION! When adjusting the blade position, be extremely careful, because your fingers can get pinched.

3.3 Tensioning the Blade

See Figure 3-1.

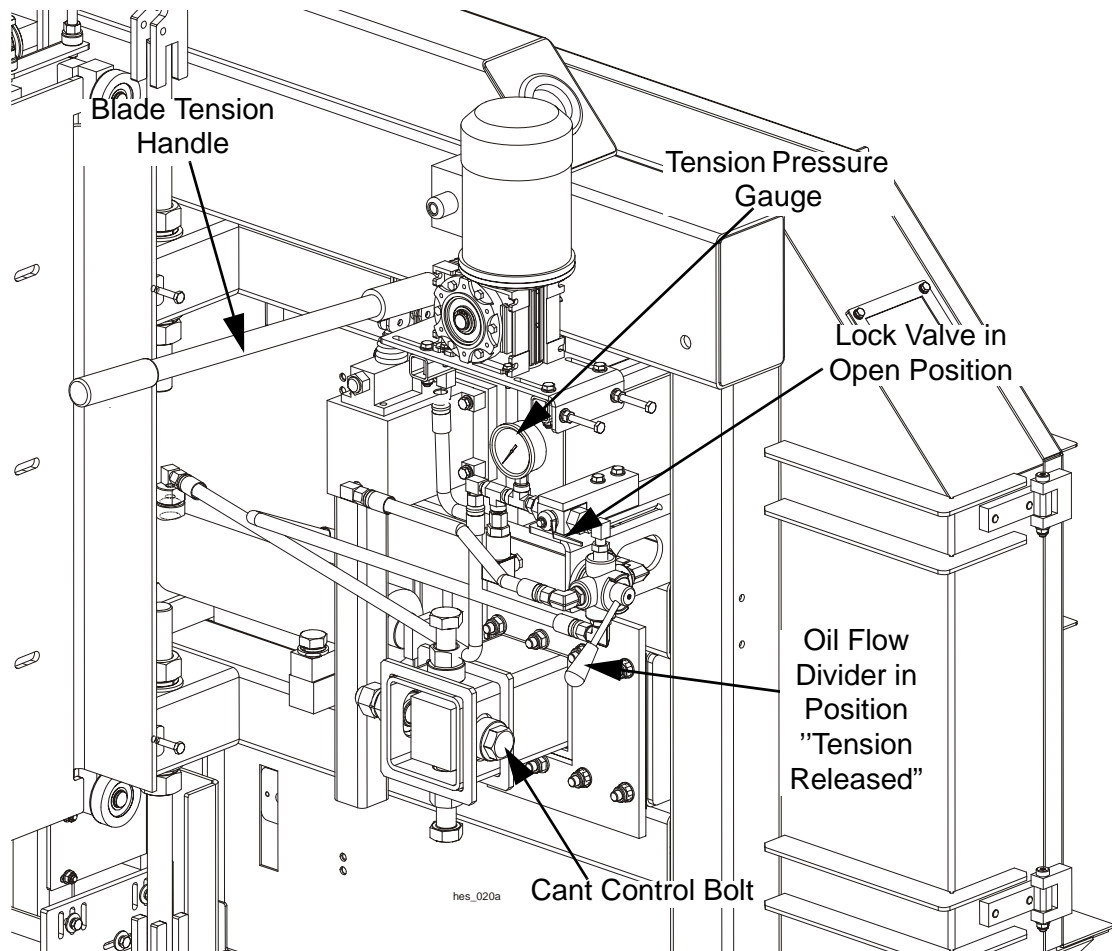

FIG. 3-1

The blade tension is adjusted with the blade tension handle and by setting properly the oil flow control valves shown in the figure above.

To release the tension, turn the lock valve right. Then turn the oil flow divider to the down position. Move the tension handle up and down to release the blade tension. Turn the lock valve left to the position "closed" and remove or install the blade.

To tension the blade, turn the lock valve left and set the oil flow divider in the up position. Moving the tension handle up and down, tension the blade until the tension pressure gauge indicates 40-50 bar (580-725 PSI). Turn the lock valve left to the position "closed" and read again the tension pressure on the gauge.

Check the blade tension occasionally when adjusting the cant control or while cutting. Also, ambient temperature changes can cause tension to change.

IMPORTANT! Loosen the blade when the machine is not in use. Tension the blade again before starting the motor.

The WM1000 sawmill is equipped with a safety switch that disengage the motor until the blade is properly tensioned (the motor is stopped also when the blade breaks).

3.4 Tracking the Blade

1. Open the blade housing.
2. Turn the key switch to the "H" position (If machine is equipped with motor brake).



3. Carefully spin by hand one of the blade wheels until the blade positions itself on them.
4. Check if the blade is properly positioned on the blade wheels.

See Figure 3-2. Position 2" (50mm) wide blades on the wheels so the gullet is 5mm (0.196") out from the front edge of the wheel and 8 mm (0.314") in case of 3" (75mm) blade.

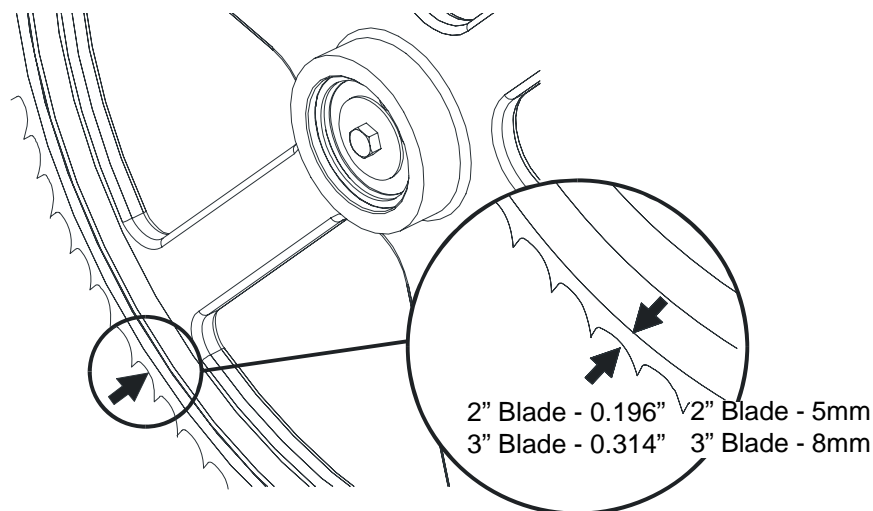

FIG. 3-2

5. Use the cant adjustment bolt, shown in **Figure 3-1**, to adjust when the blade travels on the blade wheels.

To move the blade out on the blade wheel, turn the cant adjustment bolt clockwise.

To move the blade in on the blade wheel, turn the bolt counterclockwise.

6. After making the cant adjustment, tension the blade properly and then re-check the cant adjustment.
7. Close the blade housing.



DANGER! Make sure all guards and covers are in place and secured before operating or towing the sawmill. Failure to do so may result in serious injury. Be sure the blade housing covers are in place and secured.

DANGER! After adjusting the blade wheels, always recheck the blade tracking.

3.5 Starting the Motor

See the appropriate manual supplied with your specific motor configuration for detailed starting and operating instructions.



IMPORTANT! For safe operation of the sawmill, one person is sufficient, however in case of manual collection of sawn material, at least two persons should be assigned to these activities in order not to exceed the manual lifting standard.



CAUTION! Before starting the sawmill, the operator must warn all persons who are nearby of the intention of starting the machine.



IMPORTANT! The sawmill should be operated only by a qualified person of age, being in good state of health confirmed by a medical certificate.

IMPORTANT! When starting the machine for the first time, check that the main motor rotation direction is as indicated by the arrow located on the motor body (fan guard). If the rotation direction is incorrect, invert the phases in the phase inverter in the power socket (electric box). Setting the phases in the phase inverter correctly will ensure correct rotation directions of all sawmill motors.



CAUTION! Make sure all guards and covers are in place and secured before operating. Failure to do so may result in serious injury. Be sure the blade housing covers are in place and secured.



CAUTION! Always wear eye, ear, respiration and foot protection when operating the machine. Secure all loose clothing and jewelry before operating the sawmill.

CAUTION! Before starting the sawmill, connect a sawdust extraction system to the sawdust chute and start the extraction system. [See Section 1.13](#) for the sawdust extractor specifications.

CAUTION! If at any time you need to immediately stop the blade motor, press the emergency stop button located on the control box.

Before starting the sawmill at a new location, at least once a year or after every repair have a qualified electrician (having appropriate measurement qualifications) check the insulation resistance and the electric shock protection of the electrical system.

The electric box should be protected against dust and moisture. Regularly disconnect the power supply and clean the inside of the electric box of dust, sawdust, etc. Do not operate or leave the sawmill with the electric box door open.



CAUTION! Hazardous voltage inside the electric box (even if disconnected with the main disconnect switch) and at the motor can cause shock, burns, or death. Always disconnect the power supply before servicing!

3.6 Loading and Clamping Logs



CAUTION! Be extremely careful when handling the log. Also, be sure the cutting head is moved far enough forward so the log does not hit it.

To Load Logs

1. Load the log onto the bed using a forklift, a crane, or other equipment specifically designed for that purpose.
2. Use any wedges to secure the log in the middle of the track rails.

To Clamp and Level Tapered Logs

1. Use any wooden or steel wedges of an adequate size to level the log.

3.7 Up/Down Operation

1. Install a blade and check for correct blade tension. ([See Section 2.4.](#))
2. Set the cutting head at the desired height. (The blade height scale shows the height of the blade above the track rails, bed rail or ground depending on the sawmill installation.)



See Figure 3-1. The up/down switch is located on the right side of the control panel. Push the switch up to raise the saw head; push the switch down to lower the saw head.



Hold the switch in position until the saw head reaches the desired height and then release.

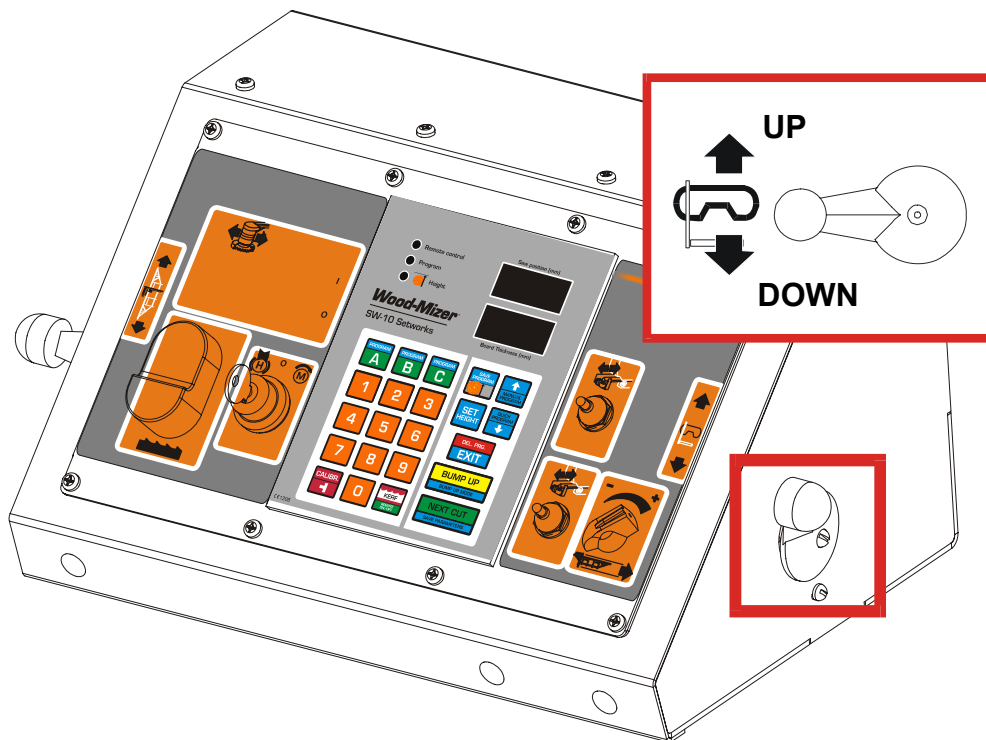

FIG. 3-5

The up/down switch is designed to return to the neutral position when released. If the switch remains engaged, manually move it to the neutral position. Repair the switch immediately.

3.8 Blade Guides Setting

1. Look down the length of the log to see its maximum width. The blade guides should be adjusted to clear the widest section of the log by about 25mm (1").
2. Use the blade guide toggle switches on the control panel to adjust the blade guides as necessary.



See Figure 3-6.

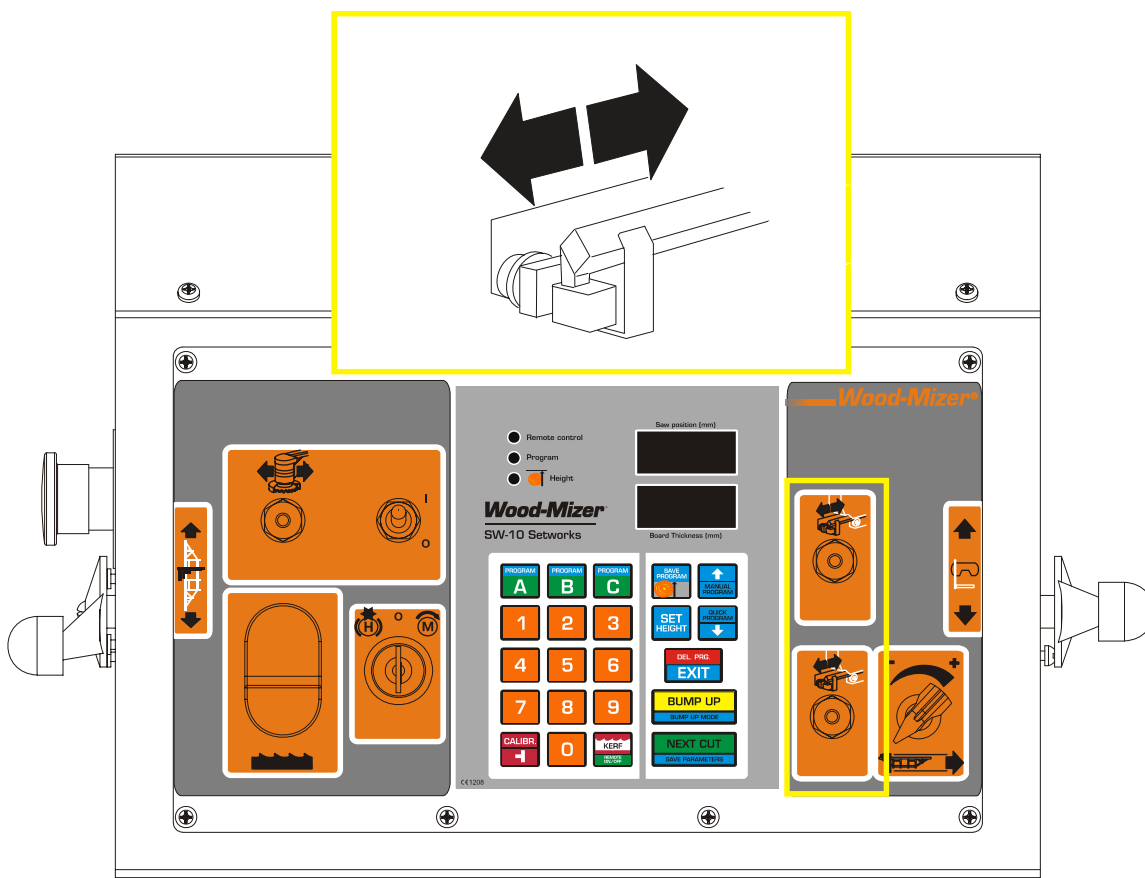

FIG. 3-6

3.9 Power Feed Operation

See Figure 3-7. The power feed system moves the saw head forward and backward by using two switches on the control panel.

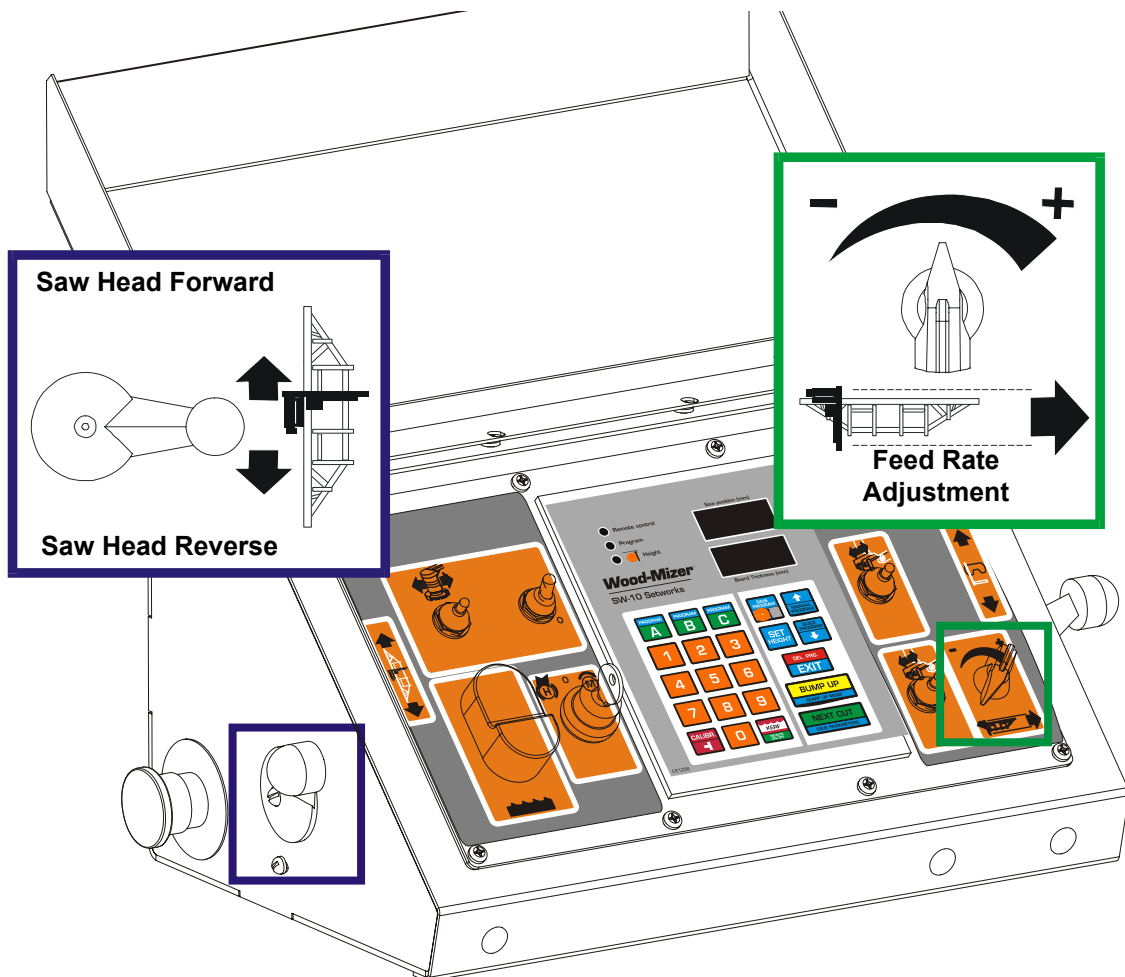

FIG. 3-7

Saw Head Feed Rate



The saw head feed rate switch controls the speed at which the saw head travels forward. Turn the switch clockwise to increase the speed; turn it counterclockwise to reduce the speed.

Saw Head Forward and Reverse



The power feed switch controls the direction in which the saw head travels. Turn the switch upward to move the saw head forward; turn it down to move the saw head backward.



NOTE: Always disengage the blade before returning the saw head and raise the saw head slightly to make sure it clears the log.

The middle position (shown in the figure above) is the neutral position. The power feed switch is designed to return to the neutral position when released. If the switch remains engaged, manually move it to the neutral position. Repair the switch. ([See Section Maintenance.](#))



WARNING! Be sure the power feed switch is in the neutral position before turning the key switch to the ON position. This prevents accidental saw head movement which may cause serious injury or death.

Feed Rate

HINT: To get a straight cut in the first part of the log, the blade should be fed into the log at a slow speed. This will stop the blade from flexing and dipping up or down. Turn the saw head feed rate switch to a slow speed until the whole width of the blade has entered the cut. Then use the saw head feed rate switch to increase the feed rate as desired. Maximum feed rate varies with width and hardness of the wood. Over-feeding results in motor and blade wear, and also produces a wavy cut.



Stop the saw head at the end of the cut by turning the saw head feed rate switch counterclockwise until the saw head stops moving.



- Using the STOP button, disengage the blade. This will stop the blade. Remove the board from the log.



CAUTION! Be sure to stop the blade when returning the saw head.

- To return the saw head to the front of the sawmill, turn the power feed switch down. The power feed motor will bypass the saw head feed rate switch and the saw head will automatically return at the fastest speed available. **Always disengage the blade before returning the saw head for the next cut.**



- Make sure that the blade does not catch on the end of the log. Raise the saw head slightly to make sure the blade clears the log when returned. **HINT:** Try to stop the blade while the heel of the blade is still on the log. Then bring the saw head back without adjusting the blade up. This lets you keep the blade at the current height so you can make the next blade height setting more quickly.

3.10 Cutting the Log

The following steps guide you through normal operation of the Wood-Mizer sawmill.

1. Once the log is placed where you want it and clamped firmly, position the blade close to the end of the log.
2. Use the blade height scale or SW-10 Setworks to determine where to make your first cut. ([See Section 3.11.](#)) Set the blade to the desired height with the up/down switch. Make sure that the blade will clear the side supports and the clamps.
3. Adjust the blade guides to clear the widest section of the log using the blade guide toggle switches.



4. Make sure all guards and covers are in place. Engage the blade. To do this, turn the key switch to the "M" position and press the START button.

5. To prevent sap buildup on the blade, open the oil tank valve. ([See Section 2.19.](#))
6. Feed the blade into the log slowly. ([See Section 3.9.](#)) Once the blade completely enters the log, increase the feed rate as desired. Always try to cut at the fastest speed you can while keeping an accurate cut. Cutting too slowly will waste blade life and lower production!
7. As you get to the end of the log, slow down the feed rate. When the teeth exit the end of the log, turn the power feed switch to the neutral position. Then disengage the blade using the STOP button. Remove the board that you have just cut from the log.
8. Use the power feed switch to move the saw head to the front of the sawmill. Always disengage the blade before returning the saw head for the next cut.
9. Repeat until the first side of the log is cut as desired. Set aside the usable flitches (boards with bark on one or both sides). You can edge them on the sawmill later.
10. Lower the toe boards if they were used (optional equipment). Release the clamps or carefully remove the wedges and turn the log 90 or 180 degrees. Using the wedges or the toeboards, level the log until the heart of it is parallel to the bed/ground.
11. Repeat the steps used to cut the first side of the log until the log is square. Cut boards from the remaining cant by adjusting the blade height for the thickness of boards that you want.

Example: Remember that the blade cuts a 1/16-1/8" (1.5-3.0 mm) wide kerf. If you want to get 1" (25 mm) thick boards, lower the saw head 1 1/16 - 1 1/8" (27-29 mm) for each board. If SW-10 Setworks is used, the kerf value is included automatically. See *SW-10 Setworks Operator's Manual*.

3.11 Blade Height Scale

See Figure 3-8. The blade height scale is attached to the saw head frame. It includes:

- a blade height indicator
- a metric/inch scale

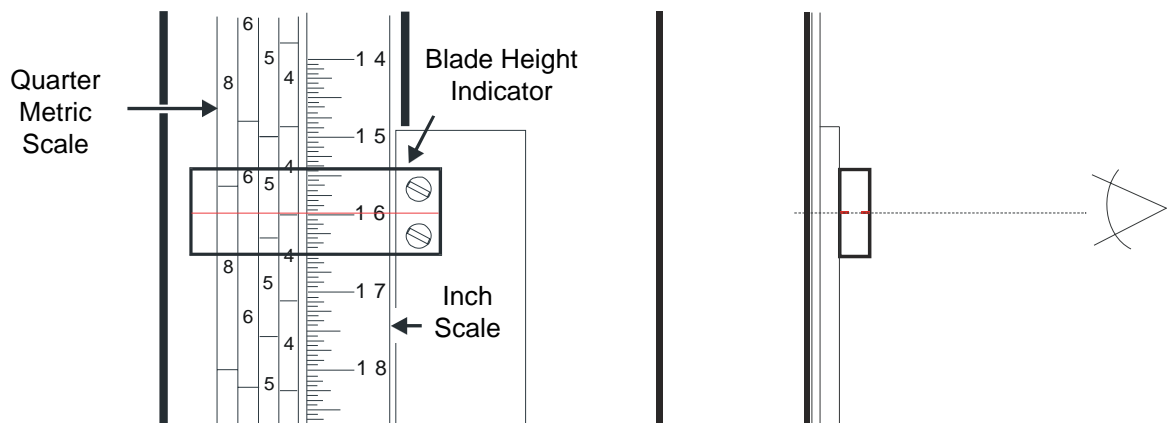

FIG. 3-8

Blade Height Indicator

The blade height indicator has two horizontal, red lines on both sides. Readings should be taken with eyes level with the indicator, when the two red lines are in line. This will allow to avoid the parallax error (different scale readings depending on the angle of vision).

Metric/Inch Scale

The horizontal red line on the blade height indicator shows how many inches the bottom of the blade is above the sawmill bed. If you know the height of your blade at each cut, you can determine the thickness of lumber you are sawing.

Example: You want to cut 1" (25mm) random width boards from a log. Position the blade for the first cut. Move the saw head to an even measurement on the scale. Make a trim cut. Return the saw head for the second cut and lower it 1 1/8" (28 mm) below the original measurement. (The extra 1/8" (3 mm) allows for saw kerf and shrinkage of the lumber.)

The yellow area on the scale identifies where the blade could encounter a side support or a log clamp (if equipped). Check that these items are below the blade level before sawing.

Quarter Scale

See Table 3-2 Two quarter scales are provided with four sets of marks. Each set represents a specific lumber thickness. Saw kerf and shrinkage allowance are included, but actual board thickness will vary slightly depending on blade thickness and tooth set.

To choose which scale to use, determine what finished thickness you want to end up with. The Grade Hardwood Quarter Scale provides thicker finished boards usually required by commercial buyers. The Standard Quarter Scale allows for kerf and shrinkage of finished boards suitable for most custom applications. Always check with your customer before you saw to determine what actual finished thickness is required.

Standard Quarter Scale		Grade Hardwood Quarter Scale	
Scale	Board Thickness	Scale	Board Thickness
4/4	1" (25 mm)	4/4	1 1/8" (29 mm)
5/4	1 1/4" (32 mm)	5/4	1 3/8" (35 mm)
6/4	1 1/2" (38 mm)	6/4	1 5/8" (41 mm)
8/4	2" (51 mm)	8/4	2 1/8" (54 mm)

TABLE 3-2

To use the quarter scale, look at the blade height indicator. Line up the horizontal red line on the indicator with the nearest mark on the scale you want to use. Make a trim cut. When you return the saw head for a second cut, lower the saw head to the next mark on the scale. This mark shows where the blade should be positioned to cut a certain thickness of lumber, without having to measure on the inch scale.

Example: You want to cut 1" (25 mm) (4/4) random width boards from a log. Position the blade for the first cut. Adjust the quarter scale so a 4/4 mark is aligned with the red line on the indicator. Make a trim cut. Return the saw head for the second cut. Now, instead of having to measure down 1 1/8" (29 mm) on the inch scale, you can simply lower the blade so the indicator is aligned with the next 4/4 mark on the quarter scale. Turn the log 90 degrees and repeat.

3.12 Lube System Operation

See **Figure 3-9**. The Lube System keeps the blade and the wheels clean and cools them. The coolant (ACP-1 oil) flows from a 5-liter tank through hoses to both sides of the blade and surfaces of the wheels. Drip feed lubricators located on the saw head control the amount of oil flow.

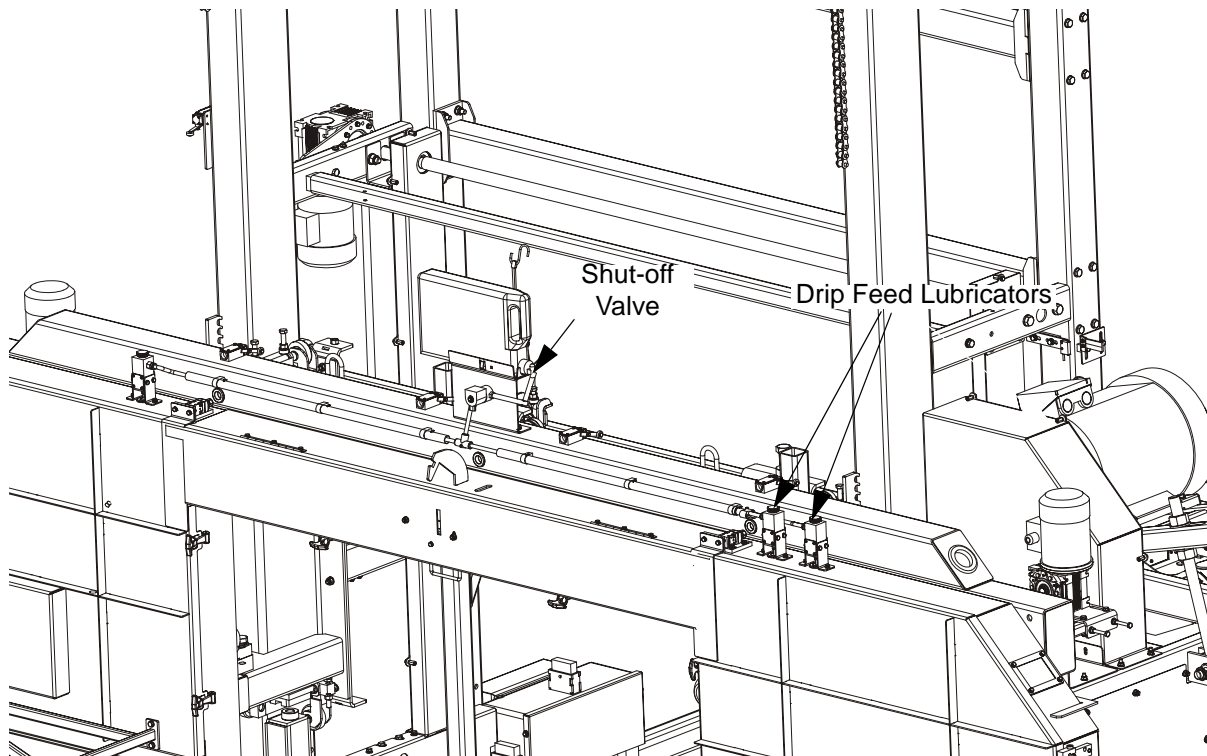

FIG. 3-9

Use just as much coolant as it is necessary to keep the blade clean. Usually, it is sufficient to set the drip feed lubricators so that one drop flows every 3 seconds.



WARNING! Never use flammable fuels or liquids! If these types of liquids are necessary to clean the blade, remove it and clean with a rag. Failure to do so may result in serious injury or death.

Before removing the blade, start the motor with the START button. Let the blade spin with oil running on it for about 15 seconds. This will clean the blade of sap buildup. Wipe the blade dry with a rag before storing or sharpening.

If you are sawing in temperatures below -20°C (-4°F), remove the oil tank from the sawmill when done sawing and store it in a warm place. Blow any remaining oil from the lube hose.

SECTION 4 MAINTENANCE

This section lists the maintenance procedures that need to be performed.

The Short Interval Maintenance Schedule lists procedures that need to be performed every 4, 8 or 25 hours. The Maintenance Log lists procedures that need to be performed every 50, 100, 200, or 1000 hours. Keep track of machine maintenance by filling in the machine hours and the date you perform each procedure.

 **This symbol** identifies the interval (hours of operation) at which each maintenance procedure should be performed.

4.1 Wear Life

See Table 4-1. This chart lists estimated life expectancy of common replacement parts if proper maintenance and operation procedures are followed. Due to the many variables which exist during sawmill operation, actual part life may vary significantly. This information is provided so that you may plan ahead in ordering replacement parts.

Part Description	Estimated Life
Up/Down Motor	2000 hours
Up/Down Drum Switch	1000 hours
Blade Guide Blocks	200 hours
Power Feed Drum Switch	1200 hours
Drive Belt	1250 hours
Power Feed Motor	1500 hours

TABLE 4-1

4.2 Blade Guides

1. Check the rollers for performance and wear every blade change. Make sure the rollers are clean and spinning freely. If not, replace them.

Steel Guide Blocks

2. Inspect the blocks for damage or wear every 100 hours of operation.

As the blocks wear, the block surfaces that contact the blade will wear more than the rest of the block. If you have access to appropriate equipment, you can grind or mill the blocks to a new flat surface and reuse them. Otherwise, it is necessary to replace the block. It is recommended you develop a routine schedule for replacing the blade guide blocks based on your sawing conditions and experience.

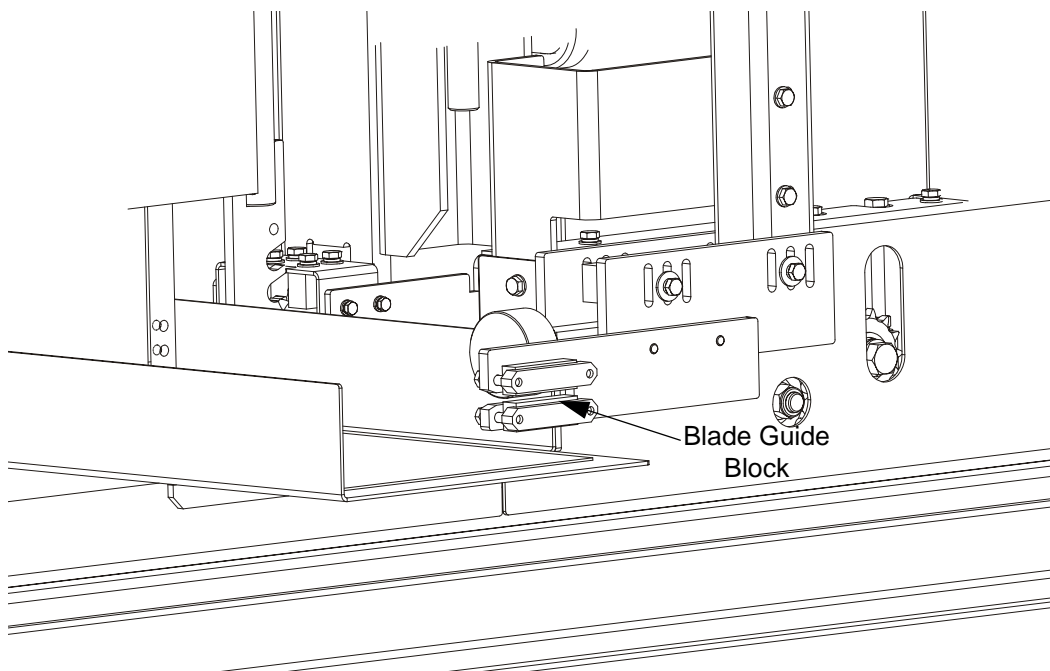

FIG. 4-1

3. Check that the blocks are properly spaced from the bottom of the blade every 25 hours of operation. The blocks should be adjusted 17-18mm (0,67 - 0,71") from the blade. [See Section: Blade Guides.](#)

25



IMPORTANT! The blocks should be parallel to the blade. Check the spacing between the disks and the blade on each side of the disks to ensure they are parallel. Inspect the blade guide assemblies for proper alignment every time you change the blade. [See Section: Blade Guides](#) for blade guide adjustment instructions.

A/R



WARNING! Blade guide alignment is essential for optimal cutting performance, blade life and safety. Failure to check and maintain proper blade guide alignment will result in stress cracks forming in the blade. These cracks will lead to premature blade breakage. If the blade breaks during operation and the blade has multiple stress cracks, the blade could

shatter into several pieces and escape from the protective guards of the sawmill. Small blade pieces projected into the area around the sawmill creates a safety hazard for the operator and any bystanders surrounding the mill.



WARNING! DO NOT use blades with stress cracks. Blades with stress cracks can shatter causing bodily injury and/or machine damage.

4.3 Sawdust Removal

1. Remove the excess sawdust from the blade wheel housings, sawdust chute and blade guides every blade change.
2. Remove all sawdust and debris from the inside of the track rollers housing.
3. Remove all sawdust from the surfaces of the mast tubes marked in the figure below.

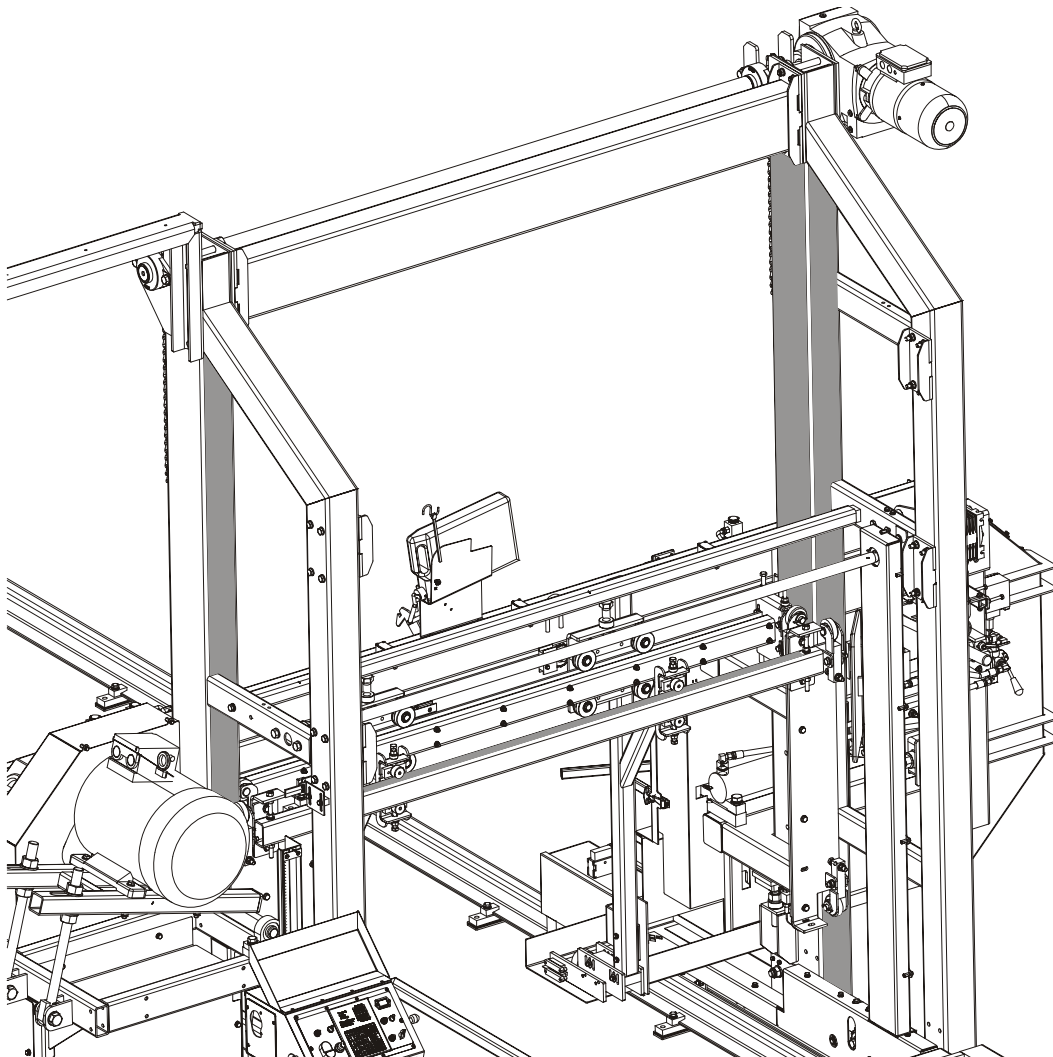



FIG. 4-2

4.4 Carriage Track, Wiper & Scrapers

Properly maintaining the sawmill carriage track is critical in preventing corrosion that can cause pitting and scaling on the rail surfaces. Pitted and scaled surfaces can, in turn, cause rough cuts or jerky power feed movement.

-  1. Clean the track rails to remove any sawdust and sap buildup every eight hours of operation.

Use a light-grade sandpaper or an emery cloth to sand off any rust or other adhering particles from the rails.

Lubricate the rails by wiping them with Dexron III ATF transmission fluid, 10W30 motor oil, or 3-in-1 turbine oil. Oil lubrication will help protect the rails from corrosive elements such as acid rain and/or moisture from nearby bodies of saltwater (if applicable). This lubrication is essential to maintain the integrity of the track rails and track rollers and to achieve long service life.

-  2. Remove sawdust from the track roller housings.

Remove the track roller housing covers and brush any sawdust buildup from the housings.

3. Check the track and the feed roller scrapers as needed. Make sure the scrapers fit firmly against the rail/roller. Replace the worn scrapers.

-  4. Check the blade wheels scrapers and felt wipers every 100 hours of operation.



IMPORTANT! Always remember to turn on the oil flow. It is not allowed to cut without oiling the blade.

See Figure 4-3.

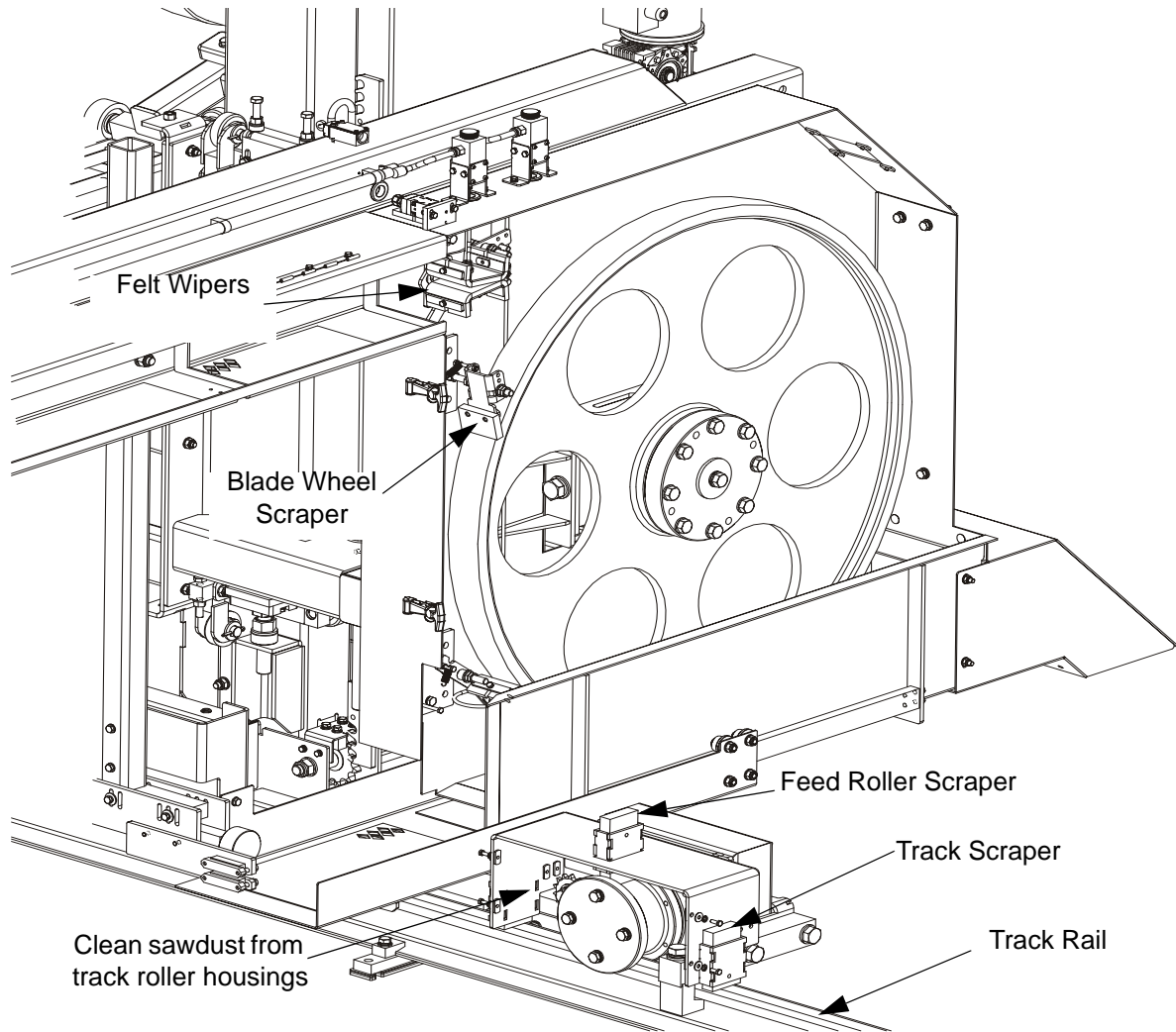

FIG. 4-3

4.5 Vertical Mast Rails

- 50 Clean and lubricate the vertical mast rails every 50 hours of operation. Clean with solvent and remove any rust with a light-grade sand paper or emery cloth. Lubricate the mast with motor oil or automatic transmission fluid (ATF).



CAUTION! Never use grease on the mast rails as it will collect sawdust.

4.6 Drum Switches

- 50 Lubricate the up/down and power feed drum switch contacts inside the control panel every fifty hours of operation. Use only contact grease supplied by Wood-Mizer. Remove the control panel cover. Use a cotton swab to apply grease to the switch contact ends.



WARNING! Drum switch grease contains Petroleum Hydrocarbon Lubricant. Eye and skin irritant. If introduced into eyes, flush with water for at least 15 minutes. If film or irritation persists, seek medical attention. Wash skin with soap and water. If ingested, do not induce vomiting - contact a physician. KEEP OUT OF THE REACH OF CHILDREN.

4.7 Miscellaneous

- 50 1. Oil all chains with Dexron III ATF every fifty hours of operation.



CAUTION! Do not use chain lube. It causes sawdust buildup in chain links.

- 50 2. Lubricate the drive blade wheel shaft with a NLGI No. 2 grade lithium grease. Apply grease to the grease fitting shown below.

See Figure 4-4.

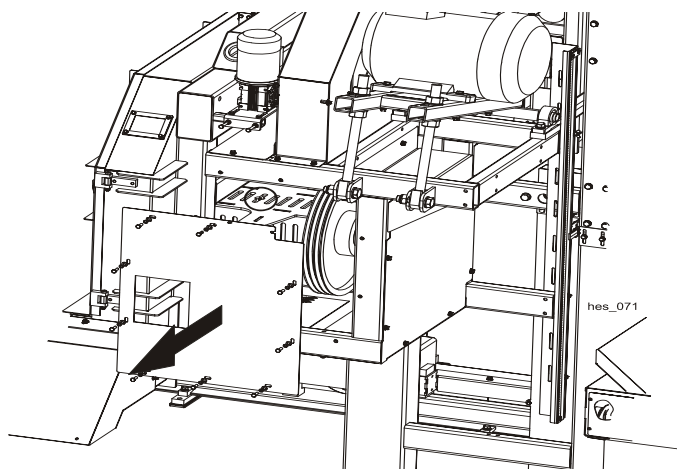



FIG. 4-4

3. Check the mill alignment every 100 hours of operation.

100
4. Make sure all safety warning decals are readable. Remove sawdust and dirt. Replace any damaged or unreadable decals immediately. Order decals from your Customer Service Representative.

4.8 Drive Belt Adjustment

 **DANGER!** Never adjust the drive belts while the motor is running. Failure to do so may result in serious injury.

AR
Periodically check the drive belt for wear. Replace any damaged or worn belts as needed.

See Figure 4-5. Adjust the drive belt tension using the nuts on the bolts supporting the motor weldment. To tighten the drive belt, loosen the upper nuts and tighten the lower nuts. To loosen the drive belt, first loosen the lower bolts and then tighten the upper bolts. The drive belt deflection in the place shown below should be 4mm (0,15") with a 15kg (33lb, 150N) force.

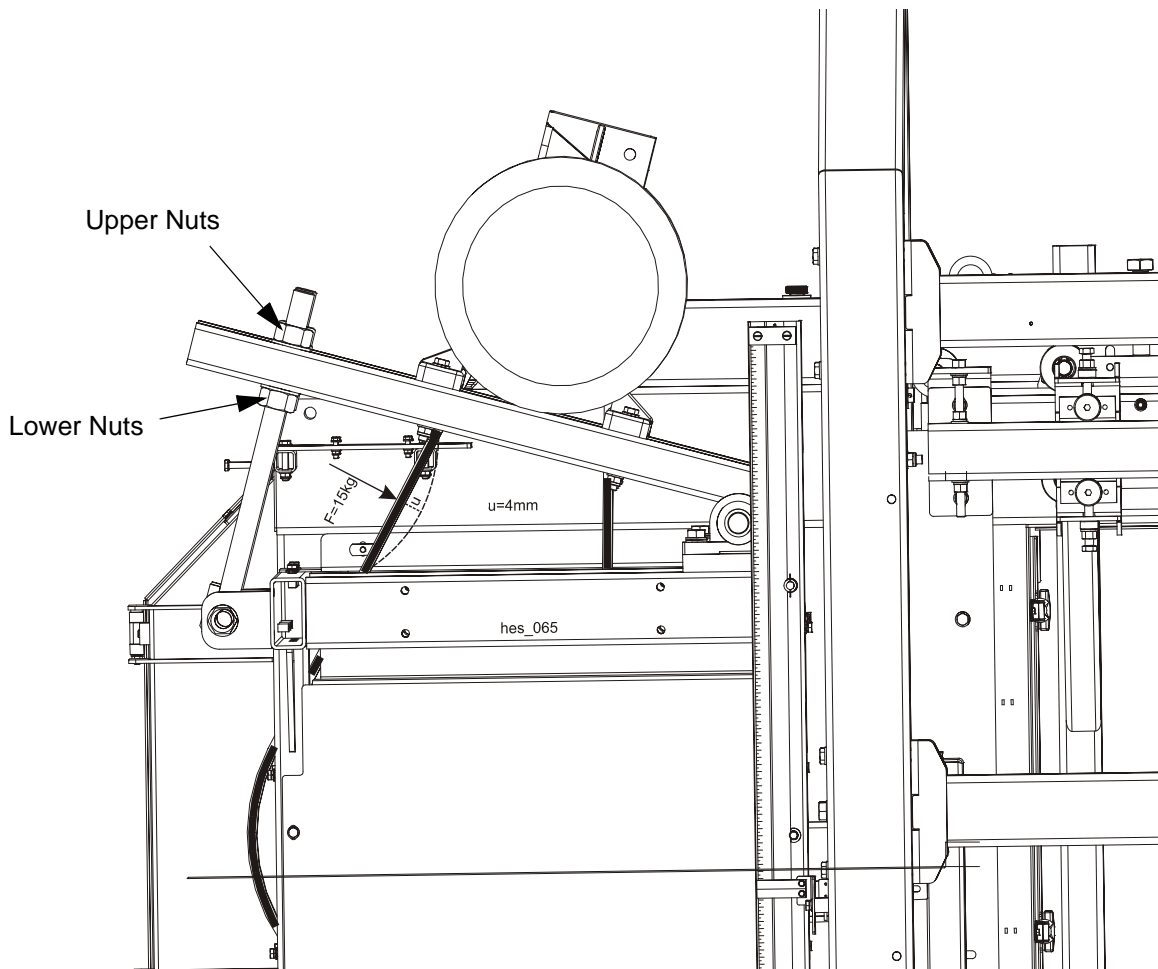

FIG. 4-5

4.9 Up/Down System

500

Adjust the up/down chain tension every 500 hours. Measure the chain tension with the head all the way to the top of the vertical mast. Find the chain adjusting bolt at the bottom of the mast. Use the adjustment bolt to adjust the bolt until the center of the chain can be deflected 2cm (0.787") with a 2.5 KG (5.5 lbf) (24.5 N), deflection force.



CAUTION! Do not overtension the chain. Overtensioning the chain may lead to early failure of the gear reducer, the sprockets and the chains.

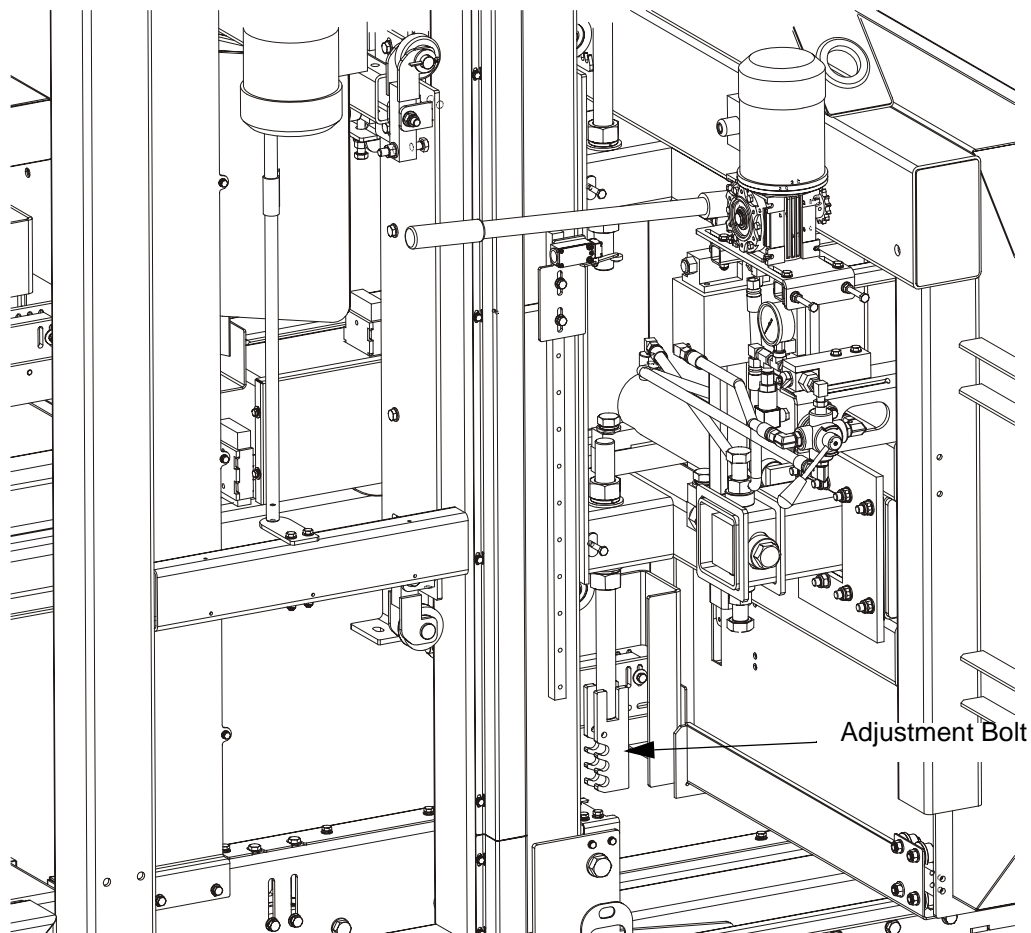

FIG. 4-5

5. Check the gear reducer for leaks. When oil leaks from the gear reducer, please contact Customer Service.

4.10 Power Feed

1. Adjust the power feed chain every 500 hours of operation. Measure the chain slack in the middle of the chain, between the feed rollers. Adjust the chain until the slack is 2 cm (0.787").

500



CAUTION! Do not overtighten the feed chain. Damage to the power feed motor may result.

See Figure 4-6. To adjust the feed chain tension, first loosen the locking bolts and then use the adjustment bolts to change the chain tension. Tighten the locking nuts when the adjustment is complete.

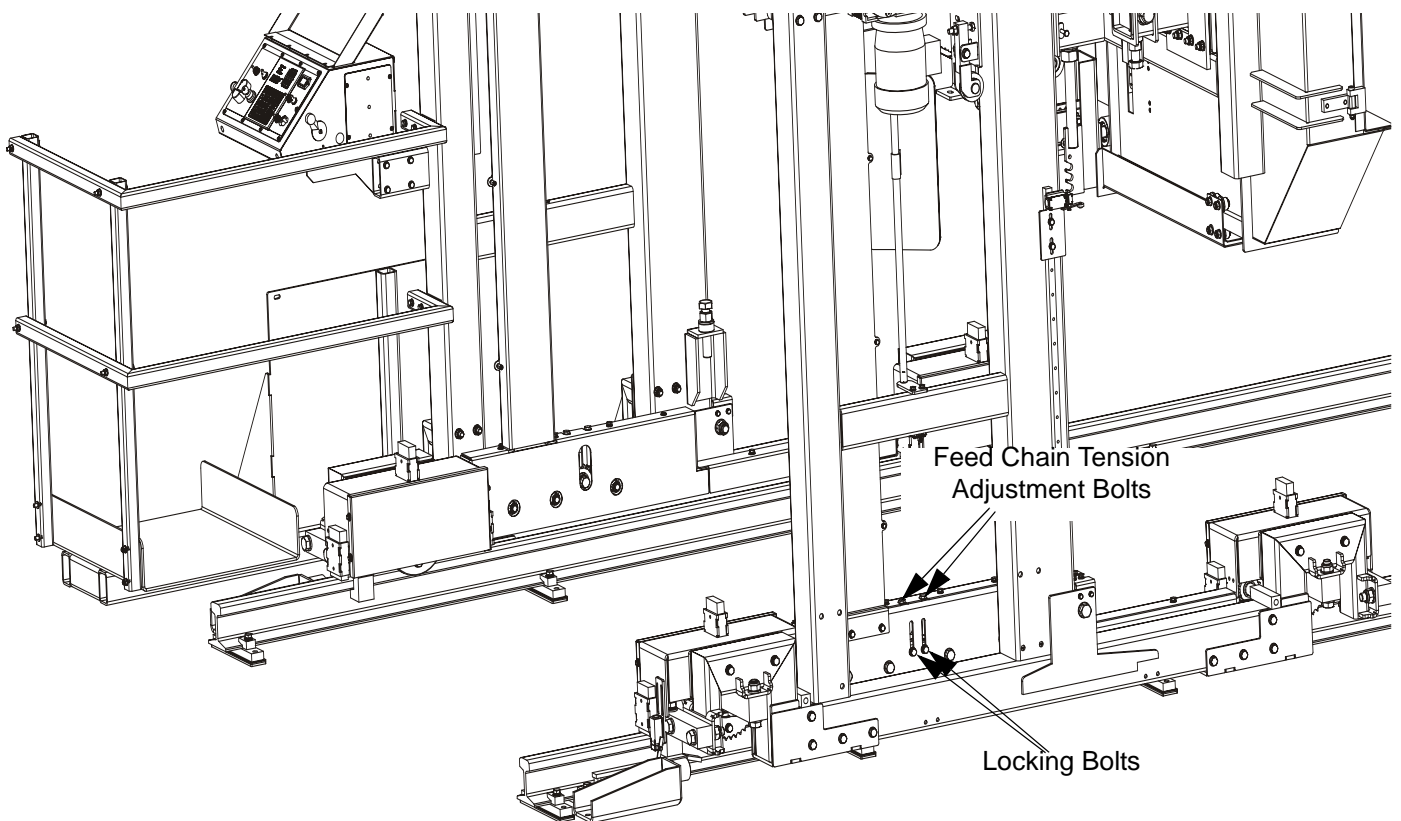

FIG. 4-6

See Figure 4-7.

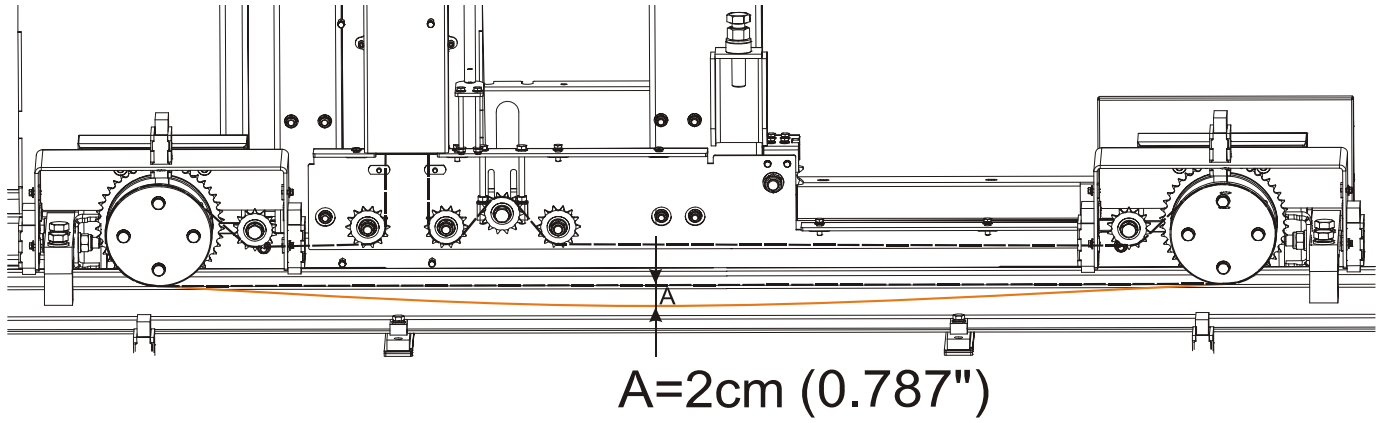

FIG. 4-7

4.11 Blade Guide Chain Tension

1. Adjust the chains of the blade guides every 500 hours of operation. Measure the blade guide chain slack with the blade guide in its most inward position. Adjust the chain until the slack is 2 cm (0.787").

500



CAUTION! Do not overtighten the chains of the blade guides. Damage to the gearbox or motor may result.

See **Figure 4-8**. To adjust the blade guide chain tension, first loosen the locking bolts and then use the adjustment bolts to change the chain tension. Tighten locking nuts.

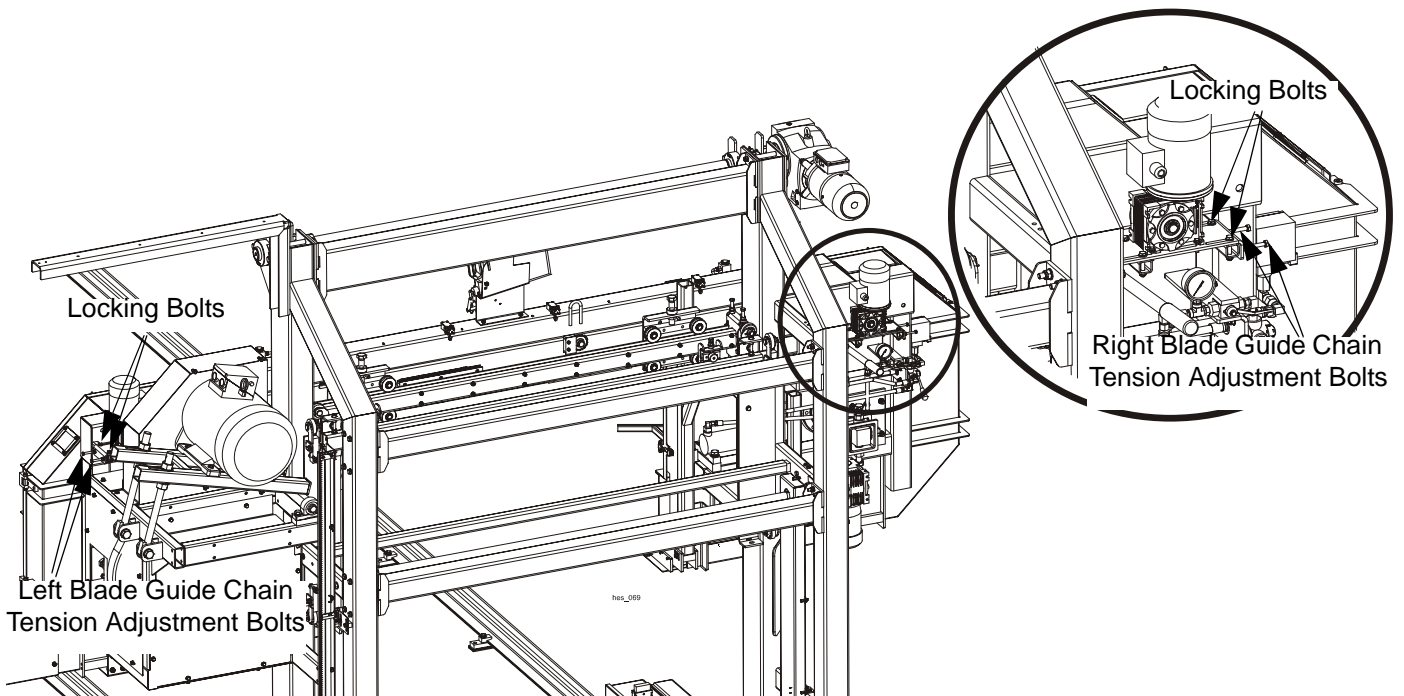

FIG. 4-8

4.12 Safety Devices Inspection

WM1000 – Safety Devices Inspection

Safety devices on the WM1000 machine which must be checked before every shift:

- E-STOP button and its circuit
- Control circuits with the E-STOP button pressed
- Blade cover safety switch #1 and its circuit
- Blade cover safety switch #2 and its circuit
- Motor brake and its circuit

1. E-STOP button and its circuit inspection

- Turn on the blade motor;
- Press the E-STOP button located on the left side of the control box. The blade motor should be stopped. Pressing the START button should not start the motor until the E-STOP button is released.

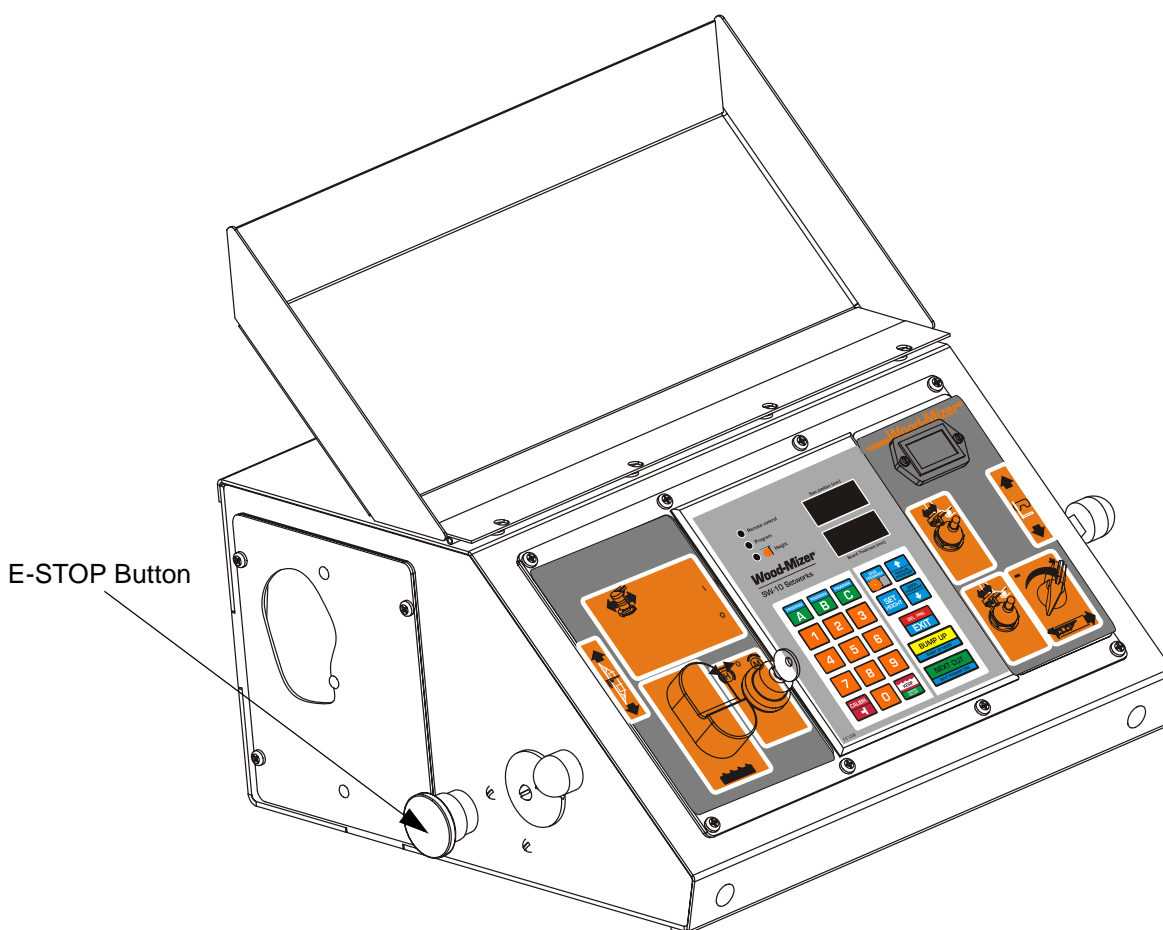

2. Inspection of the control circuits with the E-STOP button pressed

- Turn on the blade motor;
- Press the E-STOP button located on the left side of the control box. The blade motor should be stopped.
- With the E-STOP button pressed, try to move the saw head up and down using the switch and the Networks buttons, and forward/backward using the power feed switch. Both systems should not start.
- With the E-STOP button pressed, try to start the debarker blade motor and move the debarker arm in and out. The debarker should not work.
- With the E-STOP button pressed, try to move the blade guide arm in and out. The blade guide arm should not work.
- With the E-STOP button pressed, try to start the board return system. The board return system should not work.

3. Blade cover safety switch #1 and its circuit inspection

- Turn on the blade motor;
- Open the blade housing cover #1;
- The blade motor should be stopped;
- Try to start the motor. The blade motor should remain stopped;
- Close the blade housing cover #1;
- The blade motor should remain stopped until it is restarted with the START button.

4. Blade cover safety switch #2 and its circuit inspection

- Turn on the blade motor;
- Open the blade housing cover #2;
- The blade motor should be stopped;
- Try to start the motor. The blade motor should remain stopped;
- Close the blade housing cover #2;
- The blade motor should remain stopped until it is restarted with the START button.

5. Motor brake and its circuit inspection

- Turn on the blade motor. Stop the motor using the STOP button. Measure the braking time.
- Turn on the blade motor. Stop the motor by switching the key to the "0" position. Measure the braking time.
- Turn on the blade motor. Stop the motor by switching the key to the "2" position. Measure the braking time.
- The braking time should always be shorter than 10 seconds. If the braking time is longer, it is necessary to adjust or replace the motor disk brake. See your motor option manual.

SECTION 5 SAWMILL ALIGNMENT

The Alignment instructions should be performed as necessary to solve sawing problems not related to blade performance or approximately every 1500 hours of operation.

5.1 Alignment Procedure

Blade Installation

1. Check the blade and the blade wheels. Remove any sawdust buildup from the surface of the wheels.
2. Install a clean blade and apply the appropriate tension ([See Section 3.3 Tensioning the Blade](#)).
3. Check the blade guide blocks are properly adjusted ([See Section Blade Guides](#)).
4. Adjust the idle-side and drive-side cant control to track the blade ([See Section 2.7 Tracking The Blade](#)).
5. Turn the key switch to #3 position.
6. Manually spin one of the blade wheels until the blade positions itself on the blade wheels.

Saw Head Tilt

The saw head must be leveled.

1. Place a water level on the saw head main tube.
2. Use the up/down chain adjustment bolts to level the saw head.

See Figure 5-1.

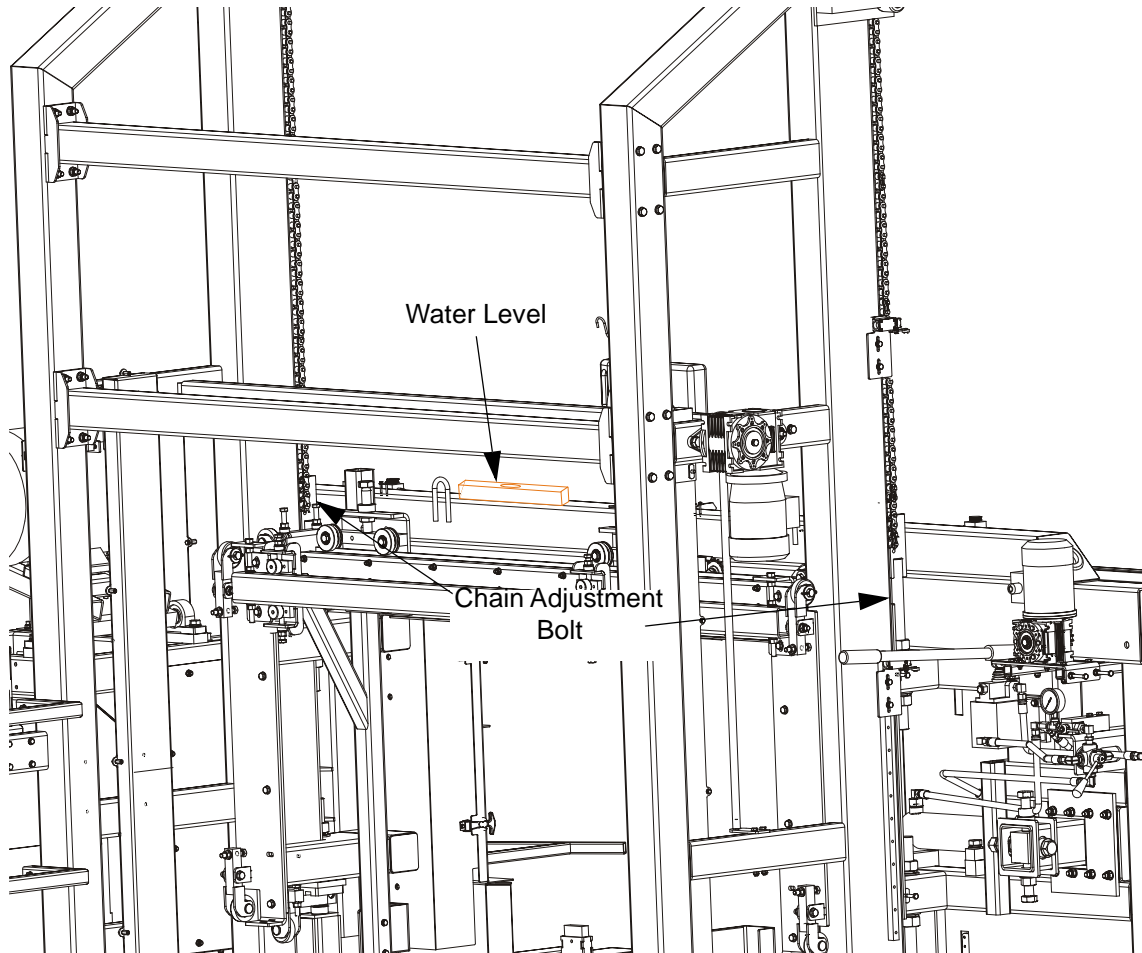

FIG. 5-1

NOTE: To make the tilt adjustment easier, it is recommended to completely lower the saw head until it rests on the stop bolts, tighten or loosen adjustment bolts. Then raise the saw head to check the saw head tilt.

3. After levelling the saw head, check the saw head rollers adjustment. All twelve rollers must touch the mast tube or may have maximum 0.5 mm (0,02") of clearance. Use the adjustment bolts shown below if necessary.

5 Sawmill Alignment
Alignment Procedure

See Figure 5-2.

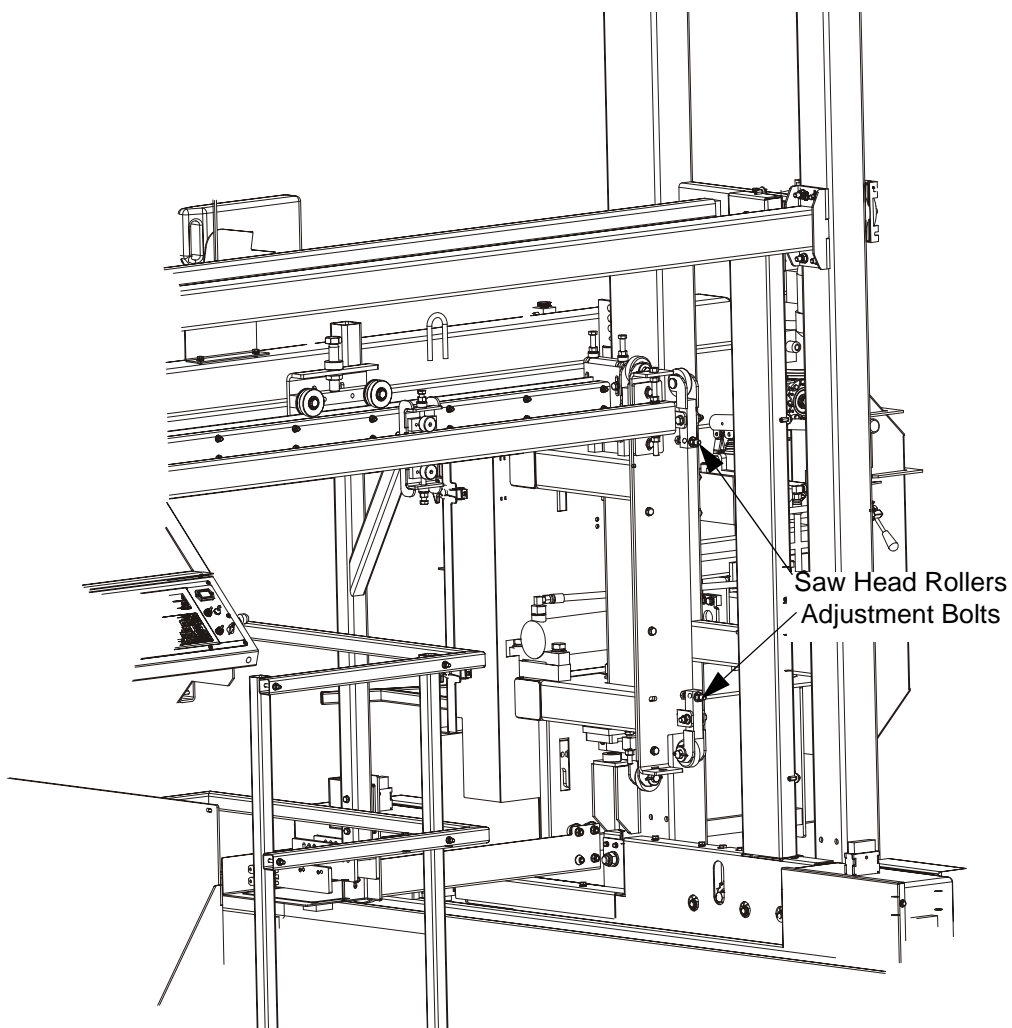

FIG. 5-2

Blade Wheels Adjustment

The blade wheels should be adjusted so they are level in the vertical and horizontal planes. If the blade wheels are tilted up or down, the blade will want to travel in the tilted direction. If the blade wheels are tilted horizontally, the blade will not track properly on the wheels.

1. Set left and right blade guide arms to its extreme outer position. Be sure the blade guide rollers or blocks do not deflect the blade. Use the blade guide alignment tool to check the vertical alignment of each blade wheel. Attach the tool to the blade near the left blade guide mount. Be sure the tool does not rest on a tooth or burr, and is lying flat against the bottom of the blade.

See Figure 5-3.

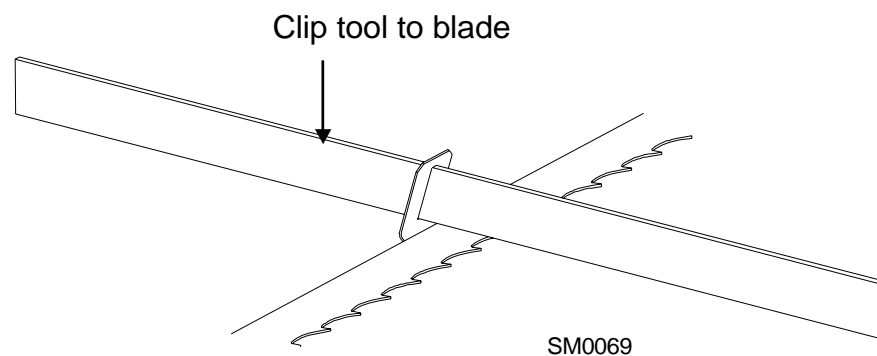

FIG. 5-3

2. Choose a reference point on the ground, floor or bed frame (if equipped).
3. Move the saw carriage so the front end of the tool is positioned over the reference point. Measure the distance from the bottom of the tool to the reference point.
4. Move the saw head so the rear of the tool is positioned over the reference point. Measure the distance from the bottom of the tool to the reference point.
5. If the two measurements differ by more than 1.5 mm (1/16"), adjust the vertical tilt of the drive-side blade wheel.

See Figure 5-4. Unbolt and remove inner cover of the the drive side wheel. Use the vertical adjustment screws to adjust the drive-side blade wheel. To tilt the wheel down, loosen two lock bolts and the top adjustment screw one quarter turn. Loosen the jam nut on the bottom adjustment screw and tighten the screw. Tighten the top and bottom jam nuts and lock bolts. To tilt the wheel up, loosen two lock bolts and the bottom adjustment screw one quarter turn. Loosen the jam nut on the top adjustment screw and tighten the screw. Tighten the top and bottom jam nuts and lock bolts. Mount the inner cover of the drive

side wheel.

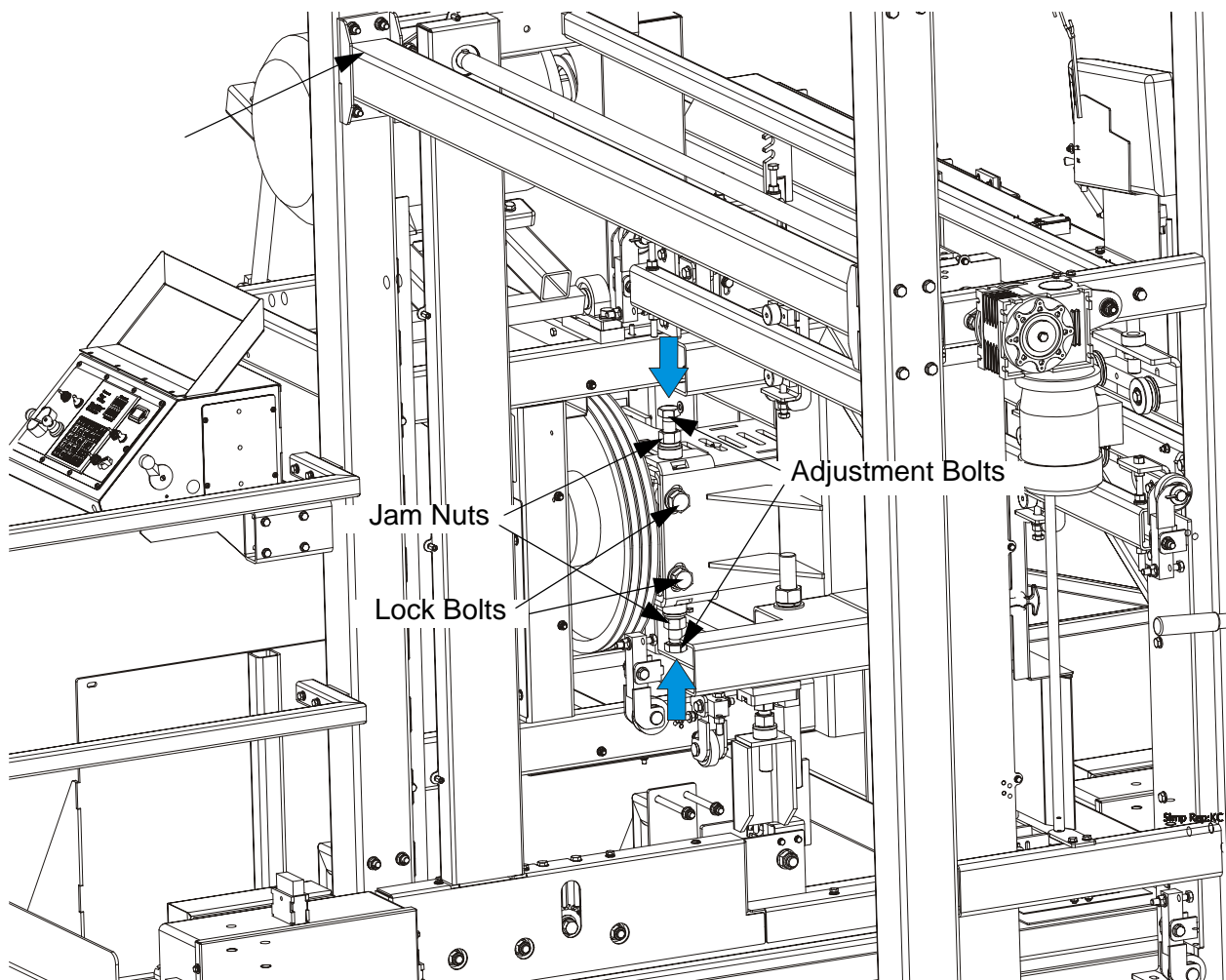

FIG. 5-4 DRIVE SIDE WHEEL VERTICAL ADJUSTMENT (SOME PARTS WERE HIDDEN INTENTIONALLY)

6. Recheck the vertical tilt of the drive-side blade wheel with the blade guide alignment tool. Readjust the blade wheel as necessary until the front and rear of the tool are the same distance from the reference point (1/16") (1.5mm).
7. Remove the tool from the blade and reattach it near the outer blade guide assembly.
8. Measure from the tool to the reference point at both ends of the tool. If the measurements at the front and rear ends of the tool differ by more than 1.5mm (1/16"), adjust the vertical tilt of the idle-side blade wheel.

See Figure 5-5. Use the vertical adjustment screws to adjust the idle-side blade wheel. To tilt the wheel up, loosen the bottom adjustment screw one quarter turn. Loosen the jam nut on the top adjustment screw and tighten the screw. Tighten the top and bottom jam nuts.

To tilt the wheel down, loosen the top adjustment screw one quarter turn. Loosen the jam nut on the bottom adjustment screw and tighten the screw. Tighten the top and bottom jam nuts.

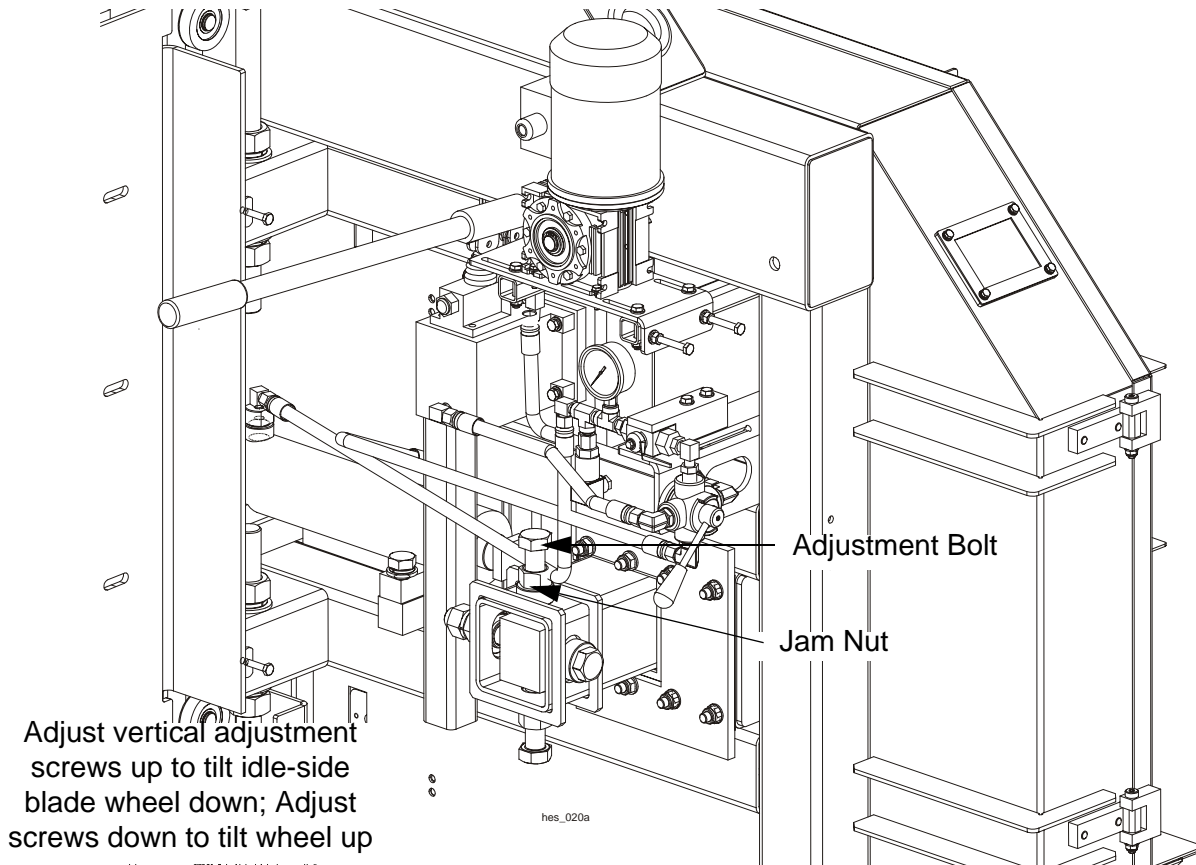

FIG. 5-5

9. Recheck the vertical tilt of the idle-side blade wheel with the blade guide alignment tool. Readjust the blade wheel as necessary until the front and rear of the tool are the same distance from the reference point (within 1.5 mm (1/16")).

10. Check the position of the blade on the idle-side blade wheel.

See Figure 5-6. The horizontal tilt of the blade wheel should be adjusted so that the gullet of a 2" (50 mm) blade is 5mm (0.196") out from the front edge of the wheel and 8 mm (0.314") in case of 3" (75 mm) blade. Do not let the teeth ride on the wheels.

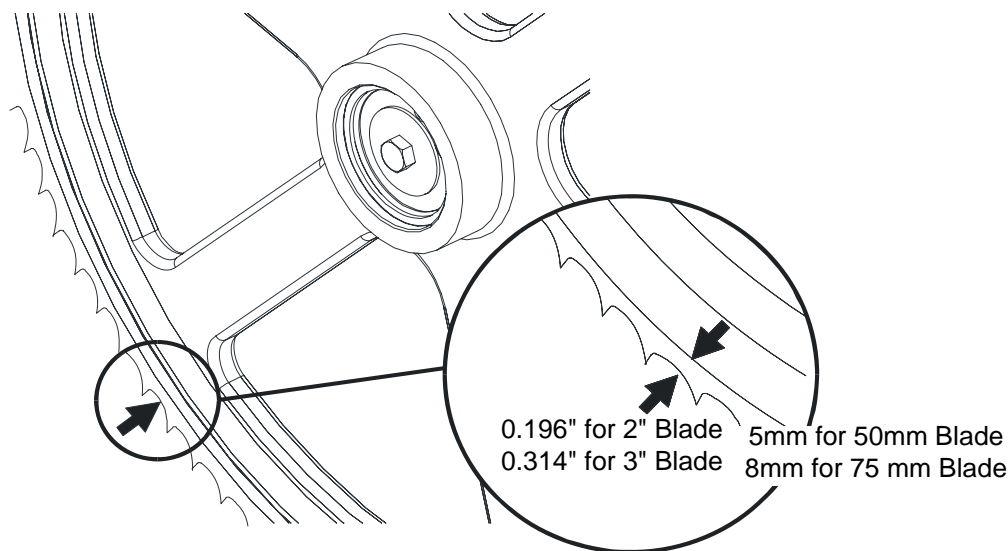

FIG. 5-6

See Figure 5-7. Use the cant control adjustment to adjust the idle-side blade wheel. If the blade is too far forward on the wheel, turn the cant control counterclockwise. If it is too far back on the wheel, turn the cant control clockwise.

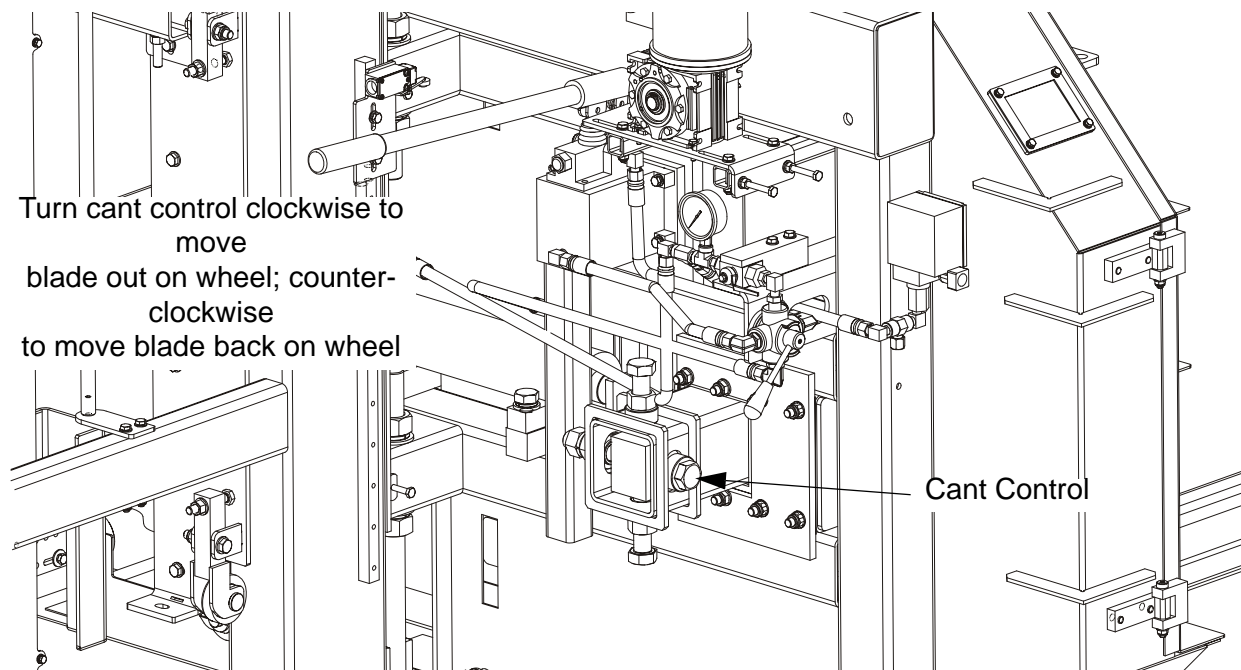

FIG. 5-7

11. Check the position of the blade on the drive-side blade wheel. The blade should be positioned on the

wheel as described for the idle-side blade wheel. Adjust the drive-side blade wheel if necessary.

See Figure 5-8. Remove the saw head side cover. Use the horizontal adjustment bolt to adjust the drive-side blade wheel. To move the blade back on the wheel, loosen the jam nuts on the adjustment bolt and turn the bolt counterclockwise. Tighten the jam nuts.

To move the blade out on the wheel, loosen the jam nuts on the adjustment bolt and turn the screw clockwise. Tighten the jam nuts. After adjustment is finished, mount the saw head side cover.

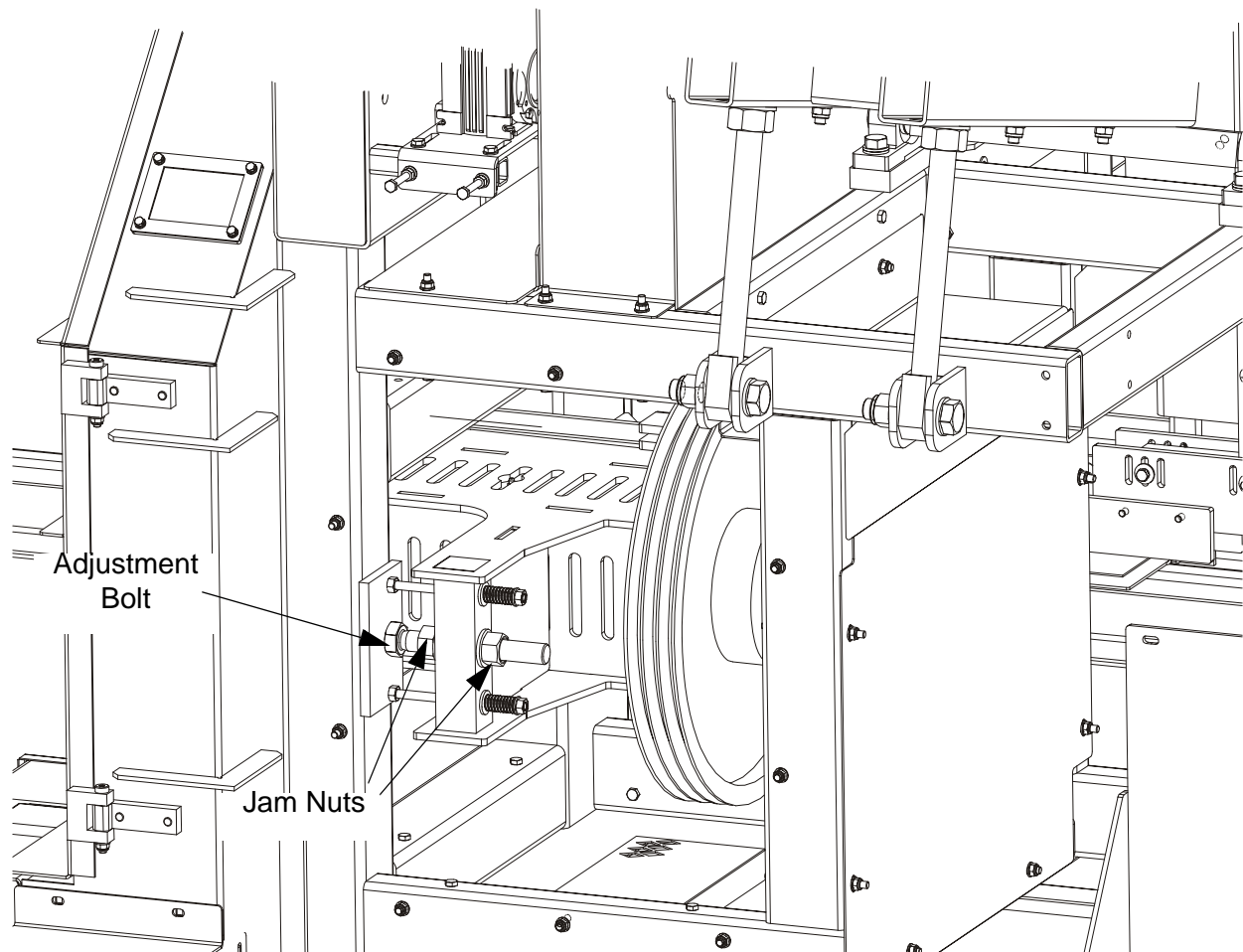

FIG. 5-8

12. After blade wheels adjustment always check drive belt tension and blade tension.

5 Sawmill Alignment

Alignment Procedure

Blade Guides

1. Check if the blade guides front horizontal tube is level.

See Figure 5-9. Place a water level on the blade guides front horizontal tube. The tube must be leveled. If adjustment is necessary, loosen the mounting bolts and lock nuts. Use adjustment bolts shown below to level this tube. Tighten lock nuts and mounting bolts when adjustment is done.

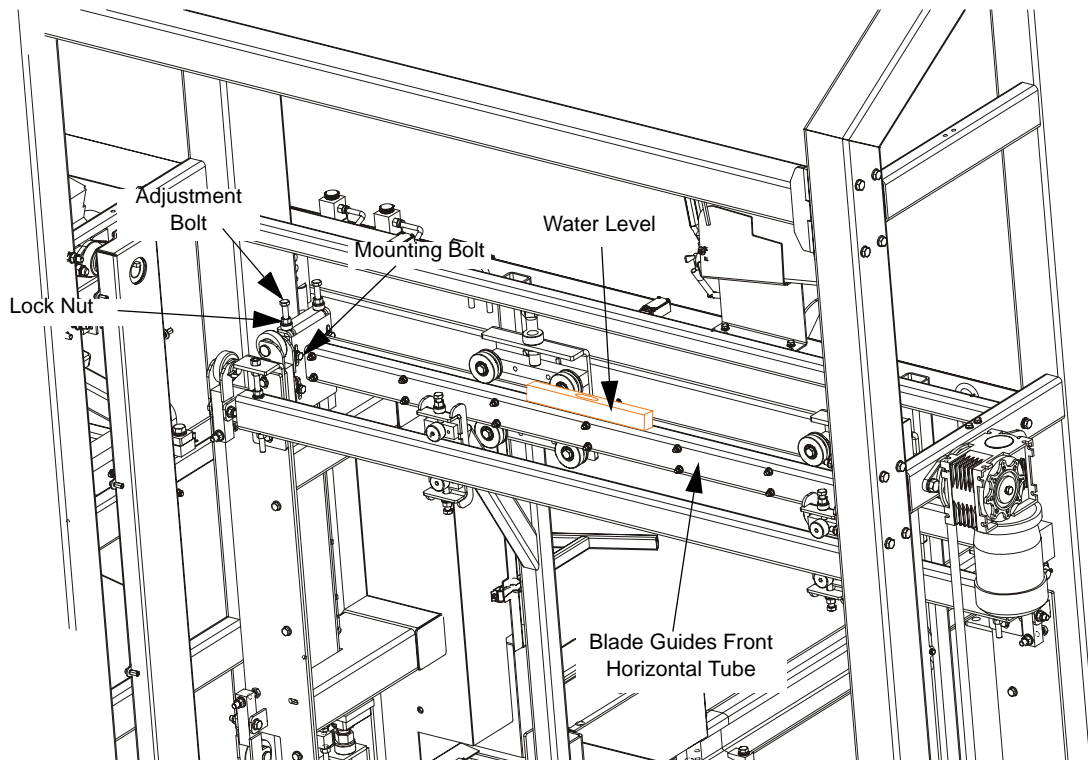

FIG. 5-9

2. Check if the blade guides back horizontal tube is level.

See Figure 5-10. Place a water level on the blade guides back horizontal tube. The tube must be leveled. If adjustment is necessary, loosen the mounting bolts and lock nuts. Use adjustment bolts shown below to level this tube. Tighten lock nuts and mounting bolts when adjustment is done.

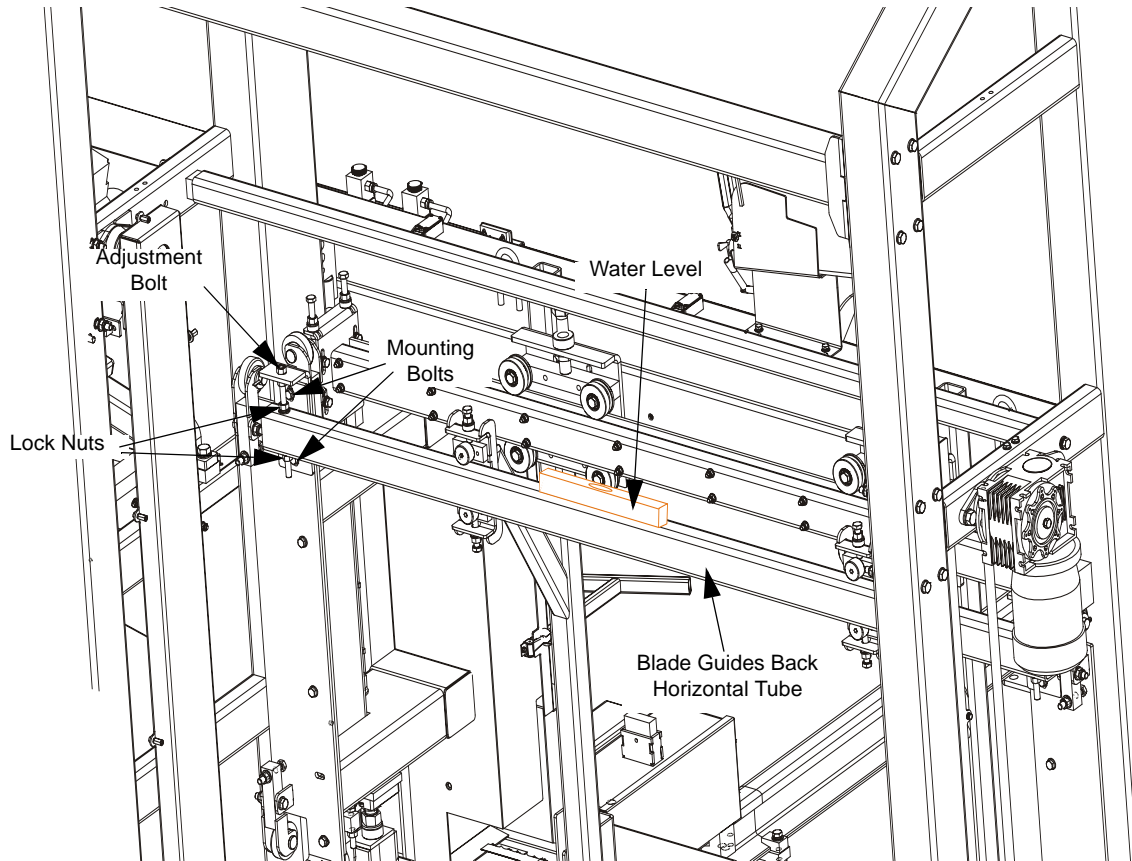

FIG. 5-10

3. Check if the blade guides vertical tubes are perpendicular.

See **Figure 5-11**. Put a water level against the left and then right blade guides vertical tubes. The tubes must be perpendicular. To adjust loosen the lock nuts and turn the adjustment bolts shown below left or right to make the vertical tube perpendicular. Tighten lock nuts when adjustment is done.

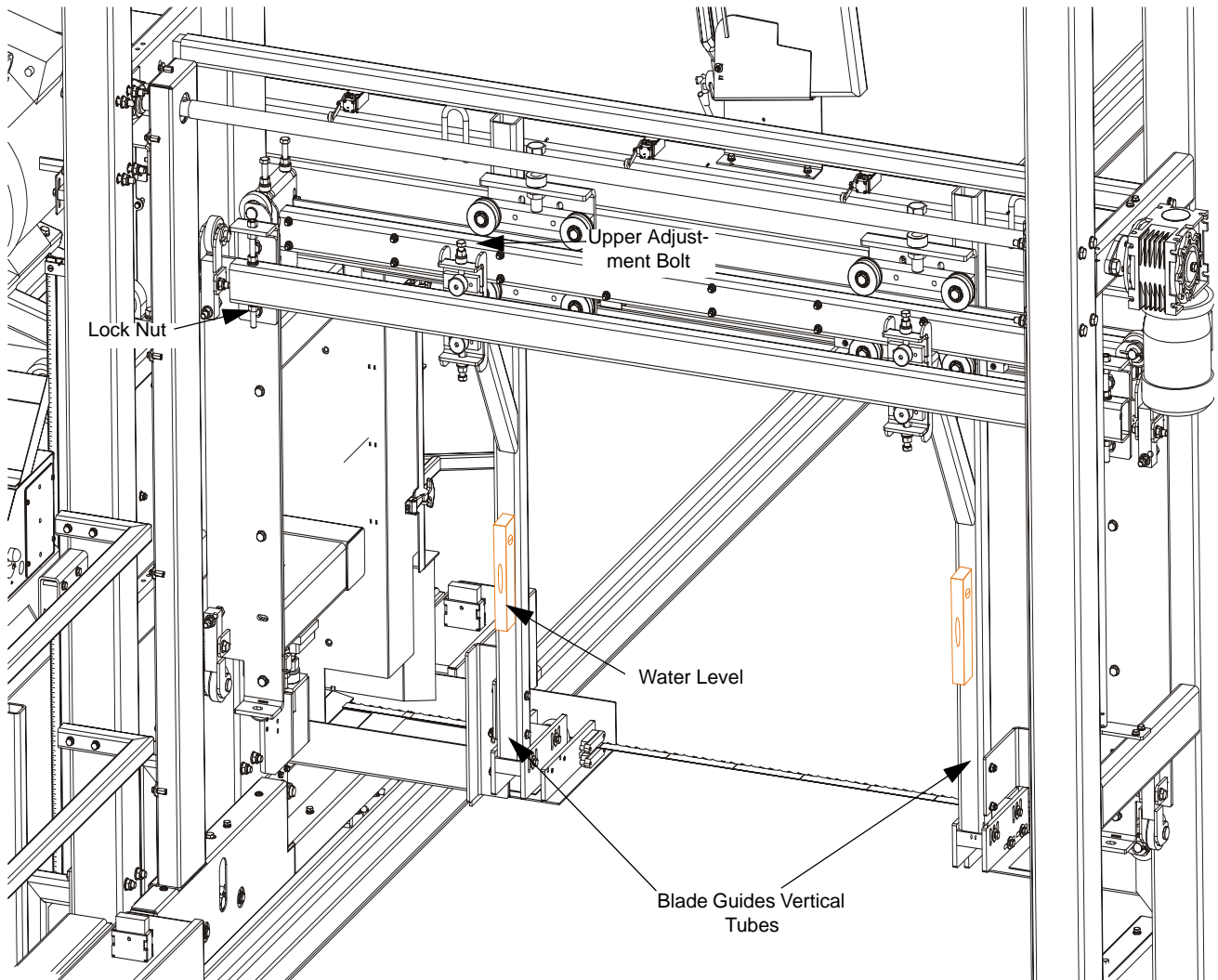

FIG. 5-11 BLADE GUIDE VERTICAL TUBES ADJUSTMENT (SOME PARTS WERE HIDDEN INTENTIONALLY)

4. Measure the distance between front surface of the blade guide roller and the back of the blade. This distance should be 8-10mm (0.314"-0.393").

See Figure 5-12.

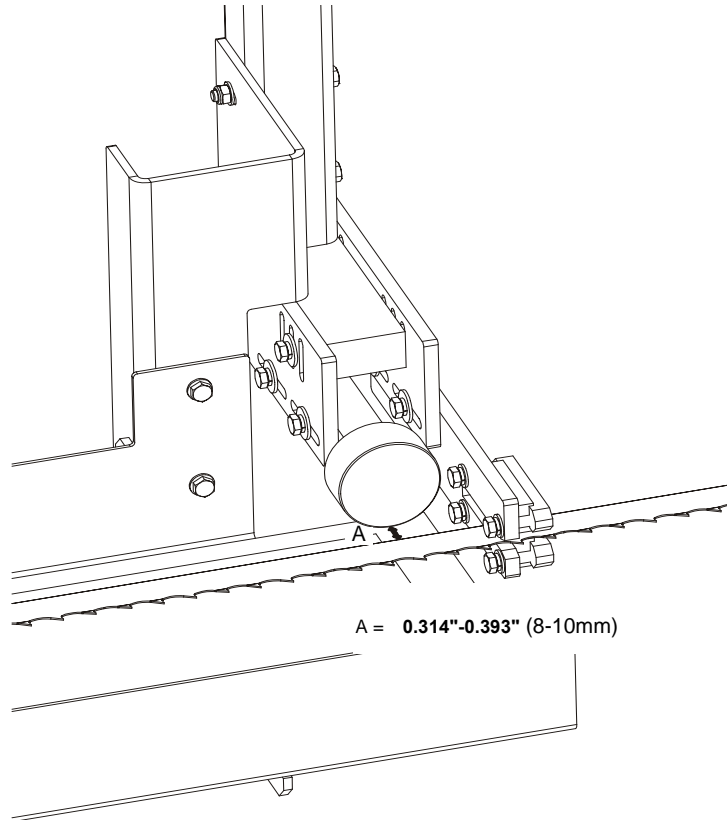

FIG. 5-12

5 Sawmill Alignment

Alignment Procedure

5. Measure the distance between bottom of the blade guide roller and the bottom side of the blade. This distance should be 17-18 mm (0.669"-0.708").

See Figure 5-13.

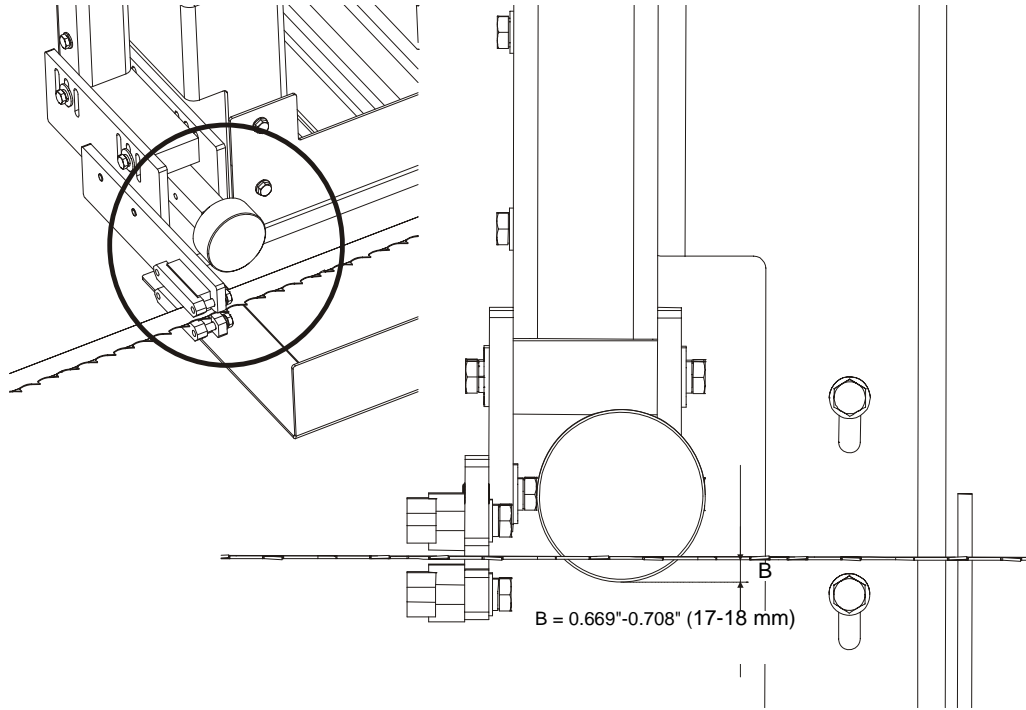

FIG. 5-13 BLADE GUIDE ADJUSTMENT (SOME PARTS WERE HIDDEN INTENTIONALLY)

6. Measure the distance between blade gullet and front surface of the upper and bottom blade guide blocks. This distance should be 5mm (0.196") for 2" (50mm) blade and 8 mm (0.314") for 3" (75mm) blade. Then check if the upper and bottom blade guide blocks slightly touches the blade on the entire length of the block.

See Figure 5-14.

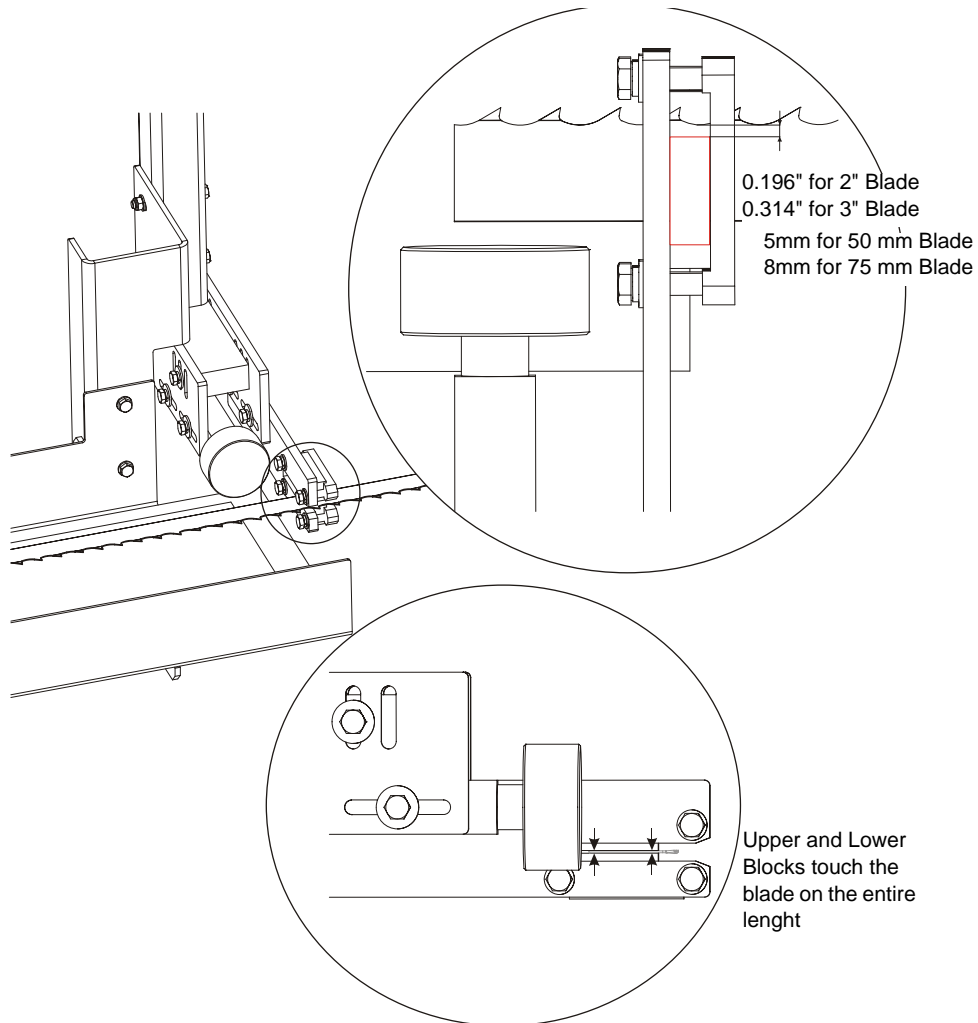

FIG. 5-14 BLADE GUIDE BLOCKS ADJUSTMENT (SOME PARTS WERE HIDDEN INTENTIONALLY)

SECTION 6 SAWMILL SPECIFICATIONS

6.1 Belt Sizes

See Table 6-1. Belt sizes for the WM1000 sawmill are shown below.

Description	Belt Size	Wood-Mizer Part #
Motor Drive Belt	3BX2640Le	--

TABLE 6-1.

6.2 Blade Specification

See Table 6-2. Blade specifications for the WM1000 sawmill are shown below.

Parameter	Value
Blade Width	50-75mm 2"-3"
Blade Length	9823mm 386.731"
Blade linear speed	17,6-21,3m/s 58-70 foot/s
Blade Tension System	Hydraulic
Blade Lubrication	Oil only

TABLE 6-2.

See The Blade Handbook for blade hook angle, tooth height, and tooth set specifications.

6.3 Cutting Capacity

See Table 6-3. The log size capacities of the WM1000 sawmill are listed below.

Parameter	Value
Min. Log Diameter	500mm 20"
Max. Log Diameter	1150-1700mm 45"-67"(depends on sawmill configuration)
Min. Log Length	1800mm 71"
Max. Log Length	depends on rails length
Min. Cut Width	200mm 8"
Max. Cut Width	1700mm 67"

TABLE 6-3.

6.4 Motor Specifications

See Table 6-4. The power options available for the WM1000 sawmill are listed below.

Motor Type	Manufacturer	W-M No.	Power	Other Specifications	Locked-rotor Current
Electric E30	Siemens	093897	22 kW	50 A, 1465 r.p.m.	6,9
Electric E40	Siemens	505394	30 kW	66 A, 1465 r.p.m.	6,7
Electric E50	Siemens	505378	37 kW	80 A, 1465 r.p.m.	6,7

TABLE 6-4.

See Table 6-5. The other motors used in sawmills are listed below.

Motor Type	Power	Locked-rotor Current
Up/Down	1,1 kW	4,4
Power Feed	1,1kW	5,1
Blade Guide Arms Motors	2x0,25kW	3,0

TABLE 6-5.

6.5 Noise Level

See Table 6-6. The average noise level is given in the table below¹².

Sawmill	Noise Level
WM1000	$L_{EX8} = 88 \text{ dB (A)}$

TABLE 6-6.

-
1. The noise level measurement was taken in accordance with PN-EN ISO 3746 Standard. The noise exposure level given above concerns an 8-hour work day.
 2. The measured values refer to emission levels, not necessarily to noise levels in the workplace. Although there is a relation between emission levels and exposure levels, it is not possible to determine with certainty if preventives are needed or are not needed. The factors affecting a current level of noise exposure during work are inter alia room characteristics and characteristics of other noise sources, e.g. number of machines and machining operations nearby. Also, the permissible exposure level value may vary depending on country. This information enables the machine's user to better identify hazards and a risk.

6 Sawmill Specifications

Overall Dimensions

6.6 Overall Dimensions

See Table 6-7. The overall dimensions of the WM1000 sawmill are listed below.

Sawmill Model	Length	Width	Height	Weight
WM1000 Stationary	10000mm (393.7") ¹	4812mm (189.448")	3380mm (133.07")	3000kg (6613lb) ² 3600kg (7936lb) ³

TABLE 6-7.

¹ If equipped with optional track rails.

² Head without rails

³ Head with 32.8 ft (10 m) long rails.

6.7 Chains

See Table 6-8. The load capacity of the chains is listed below.

	Load Capacity According to ISO Nr 08A-1
Up/Down Chains	6000 KG 13228 lb each

TABLE 6-8.

6.8 Sawdust Extractor Specifications



CAUTION! Always connect a dust extraction system before starting the machine.



CAUTION! The sawdust extraction system must be grounded or made with materials not accumulating electrostatic charge.

See **Table 6-9**. See the table below for specifications of the dust extractor.

Maximum Capacity	1200 m ³ /h (1569 yd ³ /h)
Collector Inlet Diameters (in front of fan)	150 mm (5.9 ")
Motor Power	1.5 kW
Number of Sacks for Waste	1 pcs
Total Capacity of Sacks	0,25 m ³ (8.8 ft) ³
Weight	110 kg (242.5 lb)
Conveying Speed When 10 m Long Hose Is Used	20 m/s (65.6 ft/s)

TABLE 6-9.

6.9 Lube System Specifications

The blade lubricating oil specifications are listed below.

Oil Type	Manufacturer	Freezing Temperature	Ignition Temperature	Autoignition Temperature
ACP-1E ¹	Orlen	-20° C (-4° F ⁰)	Above 140° C (284° F)	250° C (482° F)

TABLE 6-10.

¹ Waste oil must be disposed of in compliance with applicable national and local regulations.

SECTION 7 HYDRAULIC DIAGRAMS (OPTIONAL EQUIPMENT)

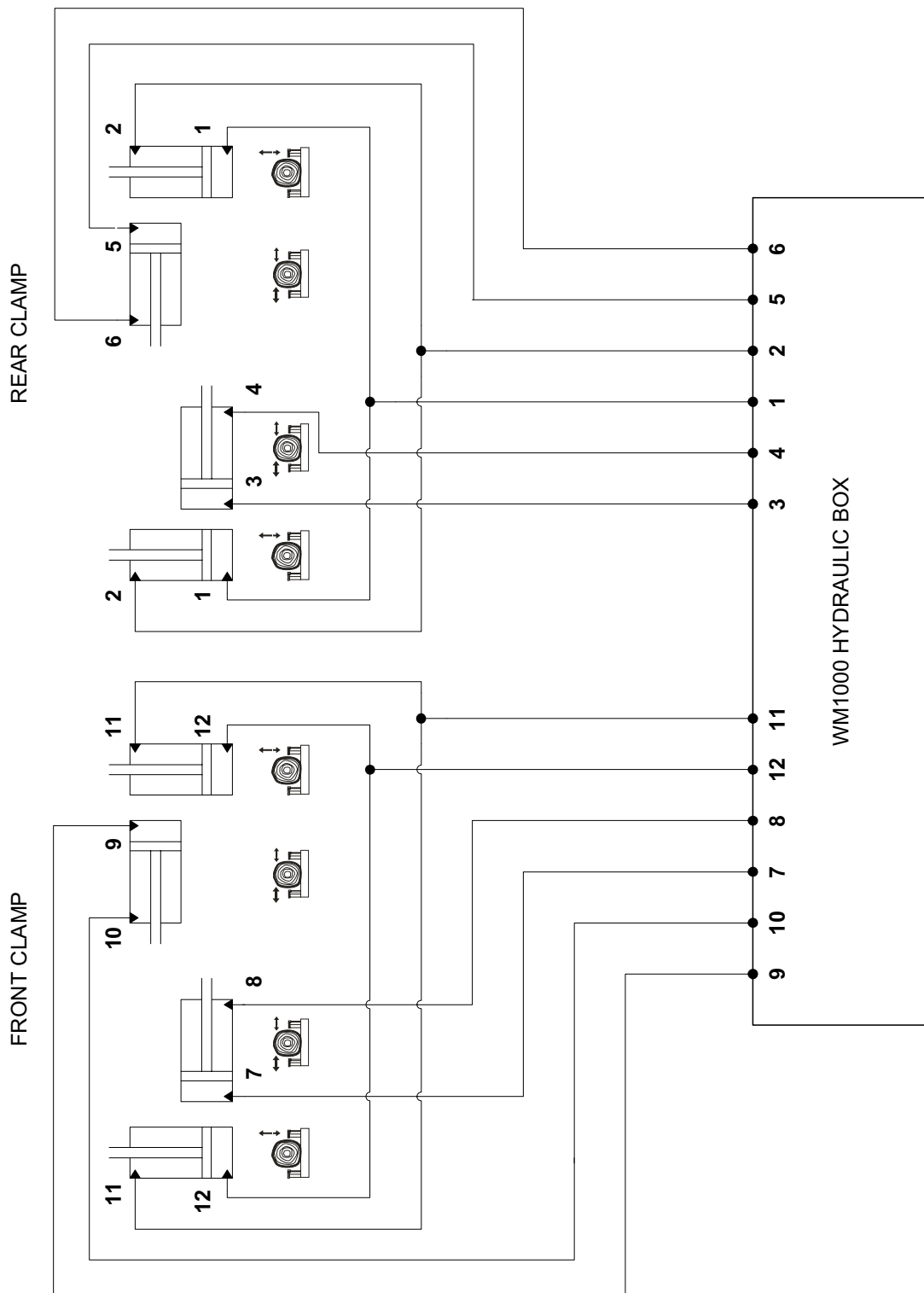
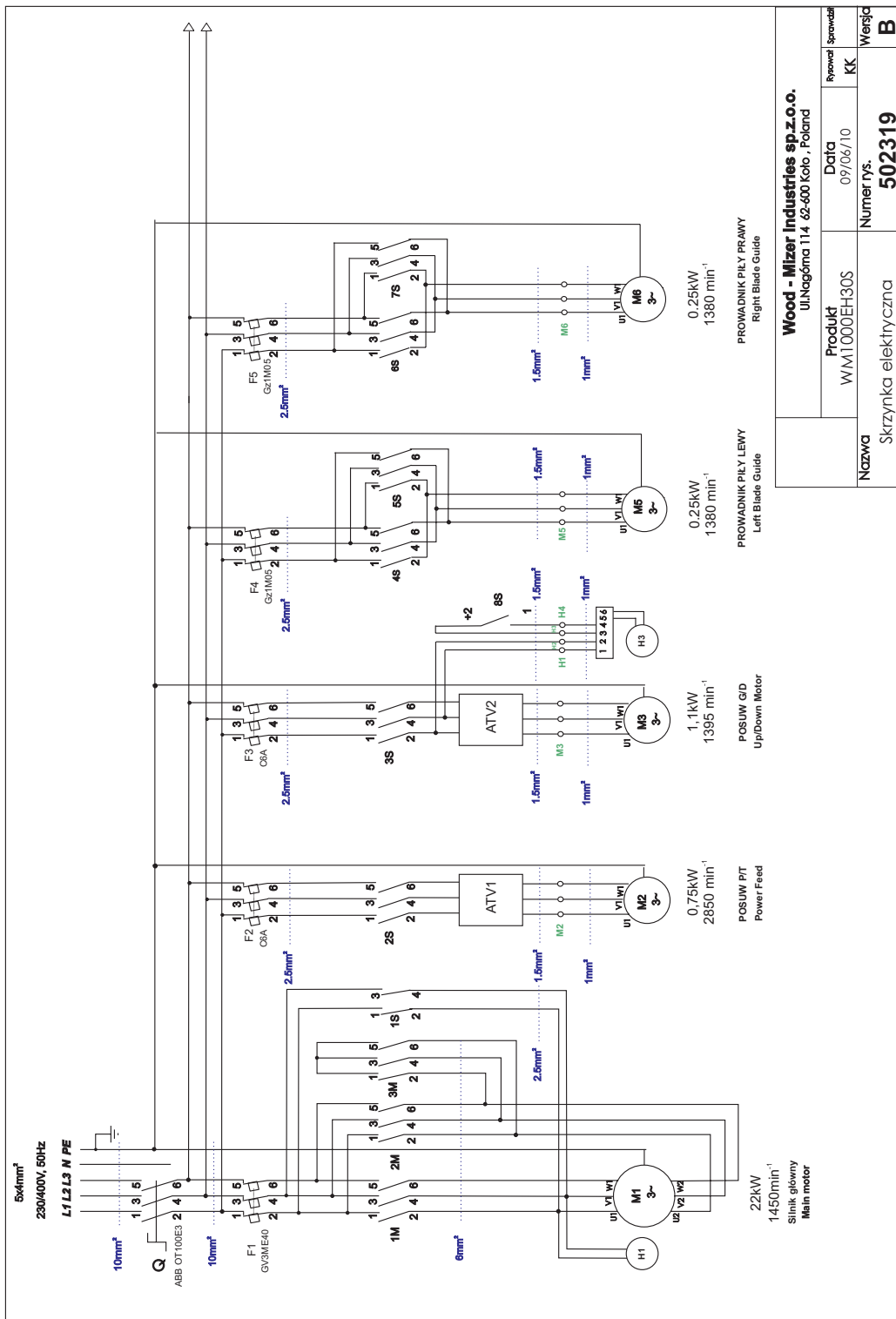

FIG. 7-0

SECTION 8 ELECTRICAL DIAGRAMS

8.1 Electrical Diagram, WM1000EH30S



Wood - Mizer Industries sp.z.o.o. ul. Nagłna 114 62-600 Kolo, Poland	
Produkt	WM1000EH30S
Data	09/06/10
Rysował	SPrawca
KK	
Nazwa	Skryzynka elektryczna
Numer rys.	502319
Wersja	B

FIG. 8-1 WM1000EH30S, PAGE 1

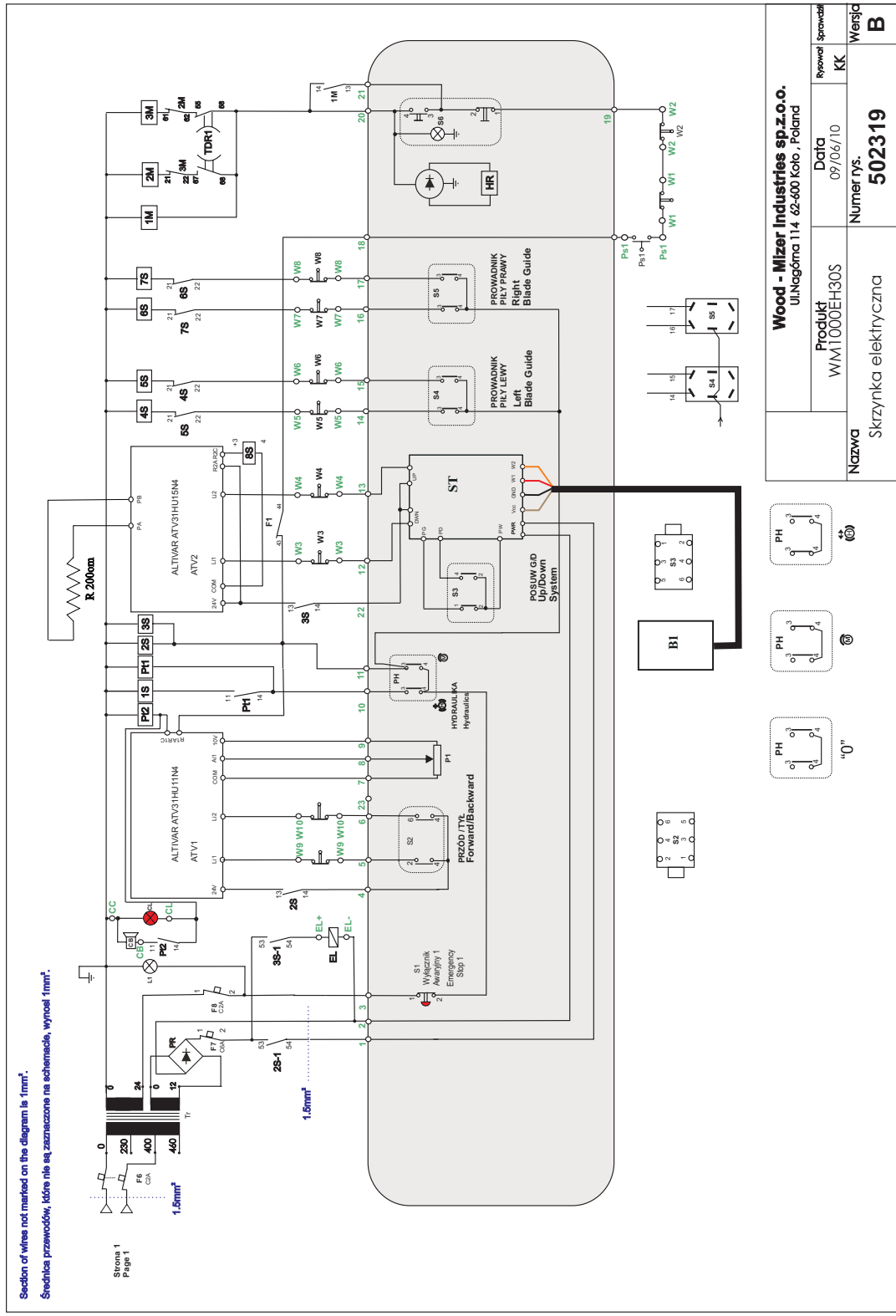

Wood - Mizer Industries sp.z o.o. Ul. Nagórna 114 62-600 Koto, Poland		Wykonawca / Sprawdził KK
Produkt WM1000EH30S	Data 09/06/10	Wersja B
Nazwa Skrzynka elektryczna	Numer rys. 502319	

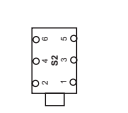
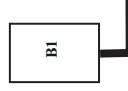
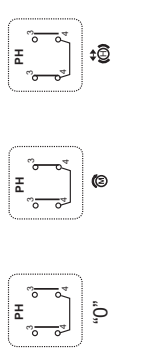

FIG. 8-2 WM1000EH30S, PAGE 2

8.2 Electrical Component List, WM1000EH30S

Symbol	Wood-Mizer Part No.	Description	Manufacturer
Q	501017	Switch, ABB OT100 F3	ABB
F1	090436	Motor Switch, GV3 P40	SCHNEIDER ELECTRIC
1M, 2M, 3M	090923	Contactora, LC1 D25 B7	SCHNEIDER ELECTRIC
TDR1	084037	Relay, LADS2 Time	SCHNEIDER ELECTRIC
M1+H	093897	Motor, 22 kW 1LG4186-4AA60-Z G26+C01	SIEMENS
1S, 2S, 3S	084308	Contactora, LC1 K610 B7	SCHNEIDER ELECTRIC
4S, 5S, 6S, 7S	084309	Contactora, LC1 K601 B7	SCHNEIDER ELECTRIC
F2, F3	091554	Circuit Breaker, C60N 3P 6A	SCHNEIDER ELECTRIC
ATV1, ATV2	093488	Controller, ATV312HU11N4	SCHNEIDER ELECTRIC
8S	503523	Solenoid, SSR D4D07 400V 7A	CRYDOM
M2	502773	Motor, SMR-63/32/0.75-1400/F3/V6 Power Feed	BESEL
M3+H3	504150	Motor, SK9032.1AZBDH-90S/4BRE20 TF 1,1kW Up/Down	NORD
M5, M6	100810	Motor, MR-40/21/0,25-1400/K3/V5 0,25kW Tray	BESEL
F4, F5	503522	Motor Switch, GZ1 M05	SCHNEIDER ELECTRIC
F6	507244	Circuit Breaker, C60N 2P C2	SCHNEIDER ELECTRIC
F7	095842	Circuit Breaker, C60N 1P 6A	SCHNEIDER ELECTRIC
F8	088278	Circuit Breaker, C60N 1P 2A	SCHNEIDER ELECTRIC
TR	506229	Transformer, TMB200/zl.576/11	INDEL
L1	090448	Control Light, M22 White	MOELLER
2S-1	097776	Contacts, LA1-KN22 Auxiliary	SCHNEIDER ELECTRIC
S1	086556	Switch, XB4 BS542 Emergency	SCHNEIDER ELECTRIC
PR	084318	Retifier, KBPC 3508 Bridge	-
EL	016140	Solenoid, Water Lube	PARKER
PT1, PT2	090515 090515-1 097612	Solenoid, 40.52.9.024.000 Socket, Solenoid 40.95.05 Series Time Module 86.20.0.024.0000	FINDER
R	503527	Resistor, MCRA 200W 160OHM Braking	LG
PS1	504830	Switch, Sealed F4-T-I-M3-16 BAR. Hyd Pressure	FOX
W1, W2	094232	Safety Switch, AZ17-11ZRK	SCHMERSAL
W3, W4	100931	Safety Switch, GLCB01A01B	HONEYWELL
W5, W6, W7, W8, W9, W10	086469	Safety Switch, GLCB01A2B	HONEYWELL
ST	500628	Controller, SW-10 Setworks	SELBIT
B1	096014	Sensor Assy, MSK-320	SIKO
P1	E20519	Potentiometer, 1K CLA 53C3-1K	HONEYWELL S&C CLAROSTAT
PH	095001	Key Switch, M22-WRS3	MOELLER

S6	090452	START-STOP Switch, M22	MOELLER
S2	E20438	Switch, 2601AF2S12 Pwr/Feed	SCHNEIDER ELECTRIC
S3	E20440	Switch, 2601AF2S10 Up/Down	SCHNEIDER ELECTRIC
S4, S5	024200	Switch Assy, 21A DPDT	Cole Hersee Company
CL+CB	503550	Column, Red-Sound Signal	MOELLER

8.3 Electrical Diagram, WM1000EH40S

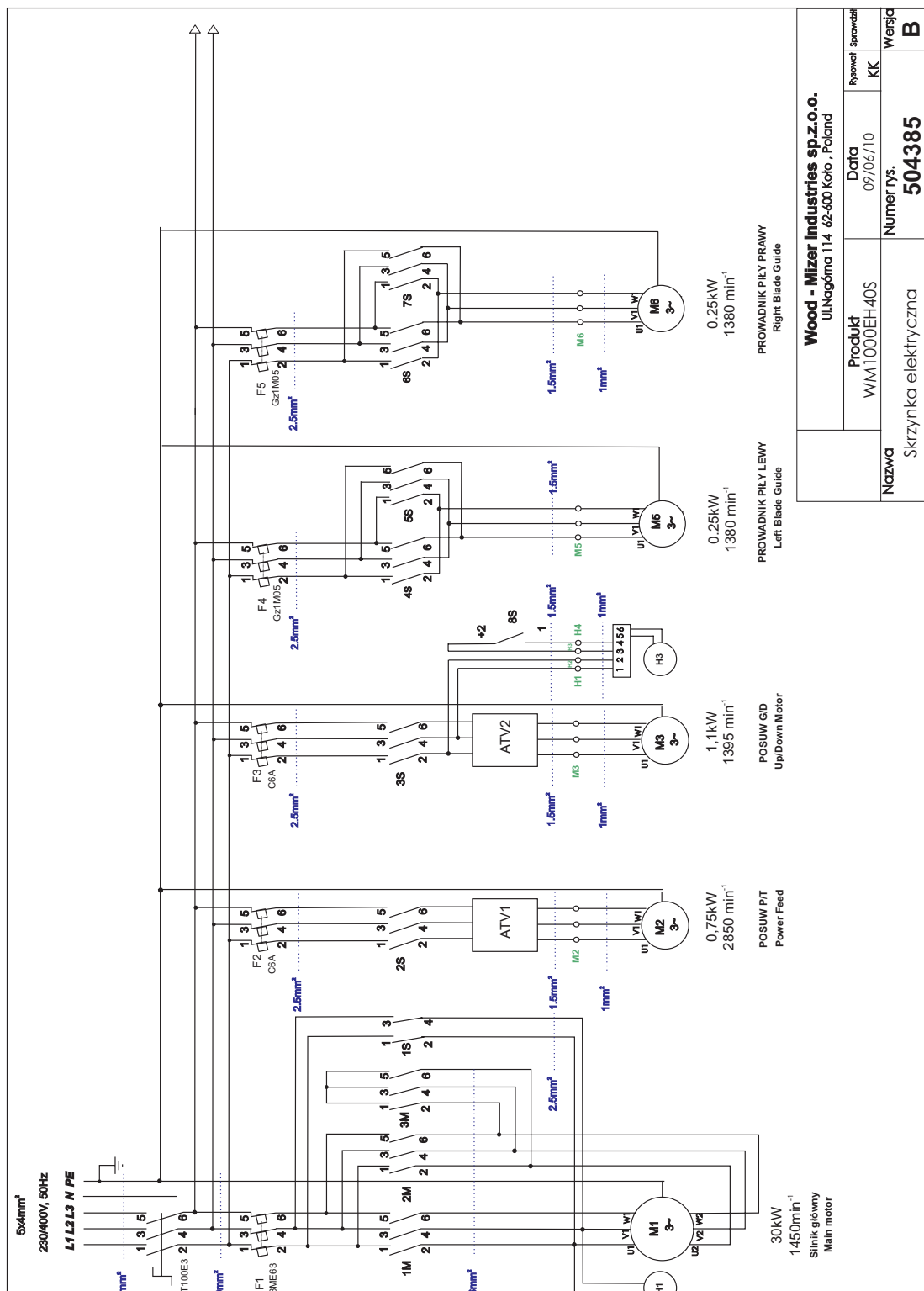

Wood - Mizer Industries sp.z.o.o. ul.Nagórna 114 62-400 Koto, Poland		Rezerwa	Sprawdzili
Produkt	Data	KK	
WM1000EH40S	09/06/10		
Nazwa	Numer rys.	Wersja	
Skrzynka elektryczna	504385	B	

FIG. 8-3 WM1000EH40S, PAGE 1

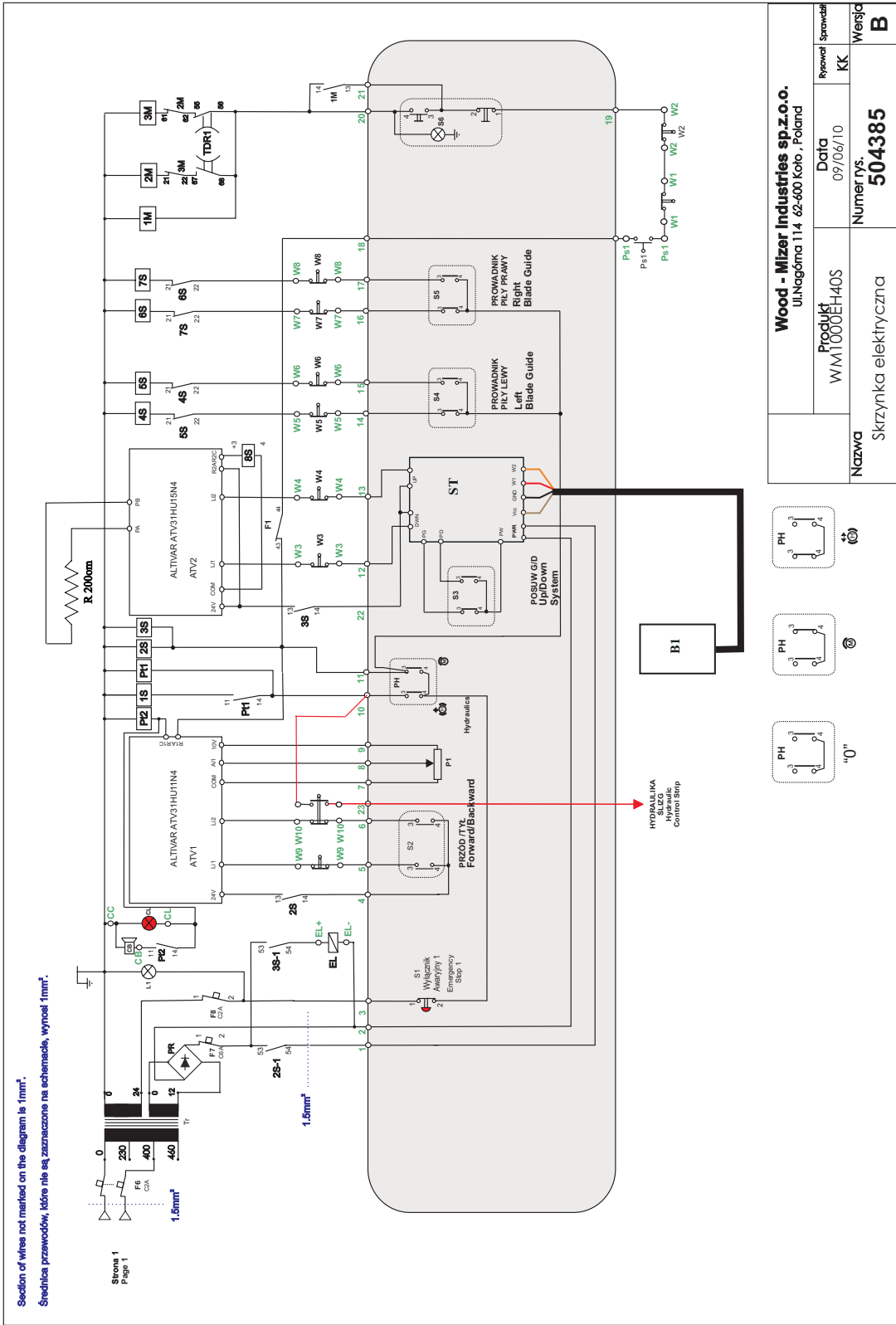

FIG. 8-4 WM1000EH40S, PAGE 2

8.4 Electrical Component List, WM1000EH40S

Symbol	Wood-Mizer Part No.	Description	Manufacturer
Q	501017	Switch, ABB OT100 F3	ABB
F1	507245	Motor Switch, GV3 ME63	SCHNEIDER ELECTRIC
1M, 2M, 3M	503464	Contactora, LC1 D38 B7	SCHNEIDER ELECTRIC
TDR1	084037	Relay, LADS2 Time	SCHNEIDER ELECTRIC
M1+H	505394	Motor, 30 kW 1LG4186-4AA60-Z G26+C01	SIEMENS
1S, 2S, 3S	084308	Contactora, LC1 K610 B7	SCHNEIDER ELECTRIC
4S, 5S, 6S, 7S	084309	Contactora, LC1 K601 B7	SCHNEIDER ELECTRIC
F2, F3	091554	Circuit Breaker, C60N 3P 6A	SCHNEIDER ELECTRIC
ATV1, ATV2	093488	Controller, ATV312HU11N4	SCHNEIDER ELECTRIC
8S	503523	Solenoid, SSR D4D07 400V 7A	CRYDOM
M2	502773	Motor, SMR-63/32/0.75-1400/F3/V6 1,1kW Power Feed	BESEL
M3+H3	504150	Motor, SK9032.1AZBDH-90S/4BRE20 TF 1,1kW Up/Down	NORD
M5, M6	100810	Motor, MR-40/21/0,25-1400/K3/V5 0,25kW Tray	BESEL
F4, F5	503522	Motor Switch, GZ1 M05	SCHNEIDER ELECTRIC
F6	507244	Circuit Breaker, C60N 2P C2	SCHNEIDER ELECTRIC
F7	095842	Circuit Breaker, C60N 1P 6A	SCHNEIDER ELECTRIC
F8	088278	Circuit Breaker, C60N 1P 2A	SCHNEIDER ELECTRIC
TR	506229	Transformer, TMB200/zl.576/11	INDEL
L1	090448	Control Light, M22 White	MOELLER
2S-1	097776	Contacts, LA1-KN22 Auxiliary	SCHNEIDER ELECTRIC
S1	086556	Switch, XB4 BS542 Emergency	SCHNEIDER ELECTRIC
PR	084318	Retifier, KBPC 3508 Bridge	-
EL	016140	Solenoid, Water Lube	PARKER
PT1, PT2	090515 090515-1 097612	Solenoid, 40.52.9.024.000 Socket, Solenoid 40.95.05 Series Time Module 86.20.0.024.0000	FINDER
R	503527	Resistor, MCRA 200W 160OHM Braking	LG
PS1	504830	Switch, Sealed F4-T-I-M3-16 BAR. Hyd Pressure	FOX
W1, W2	094232	Safety Switch, AZ17-11ZRK	SCHMERSAL
W3, W4	100931	Safety Switch, GLCB01A01B	HONEYWELL
W5, W6, W7, W8, W9, W10	086469	Safety Switch, GLCB01A2B	HONEYWELL
ST	500628	Controller, SW-10 Setworks	SELBIT
B1	096014	Sensor Assy, MSK-320	SIKO
P1	E20519	Potentiometer, 1K CLA 53C3-1K	HONEYWELL S&C CLAROSTAT
PH	095001	Key Switch, M22-WRS3	MOELLER

S6	090452	START-STOP Switch, M22	MOELLER
S2	E20438	Switch, 2601AF2S12 Pwr/Feed	SCHNEIDER ELECTRIC
S3	E20440	Switch, 2601AF2S10 Up/Down	SCHNEIDER ELECTRIC
S4, S5	024200	Switch Assy, 21A DPDT	Cole Hersee Company
CL+CB	503550	Column, Red-Sound Signal	MOELLER

8.5 Electrical Diagram, WM1000EH50S

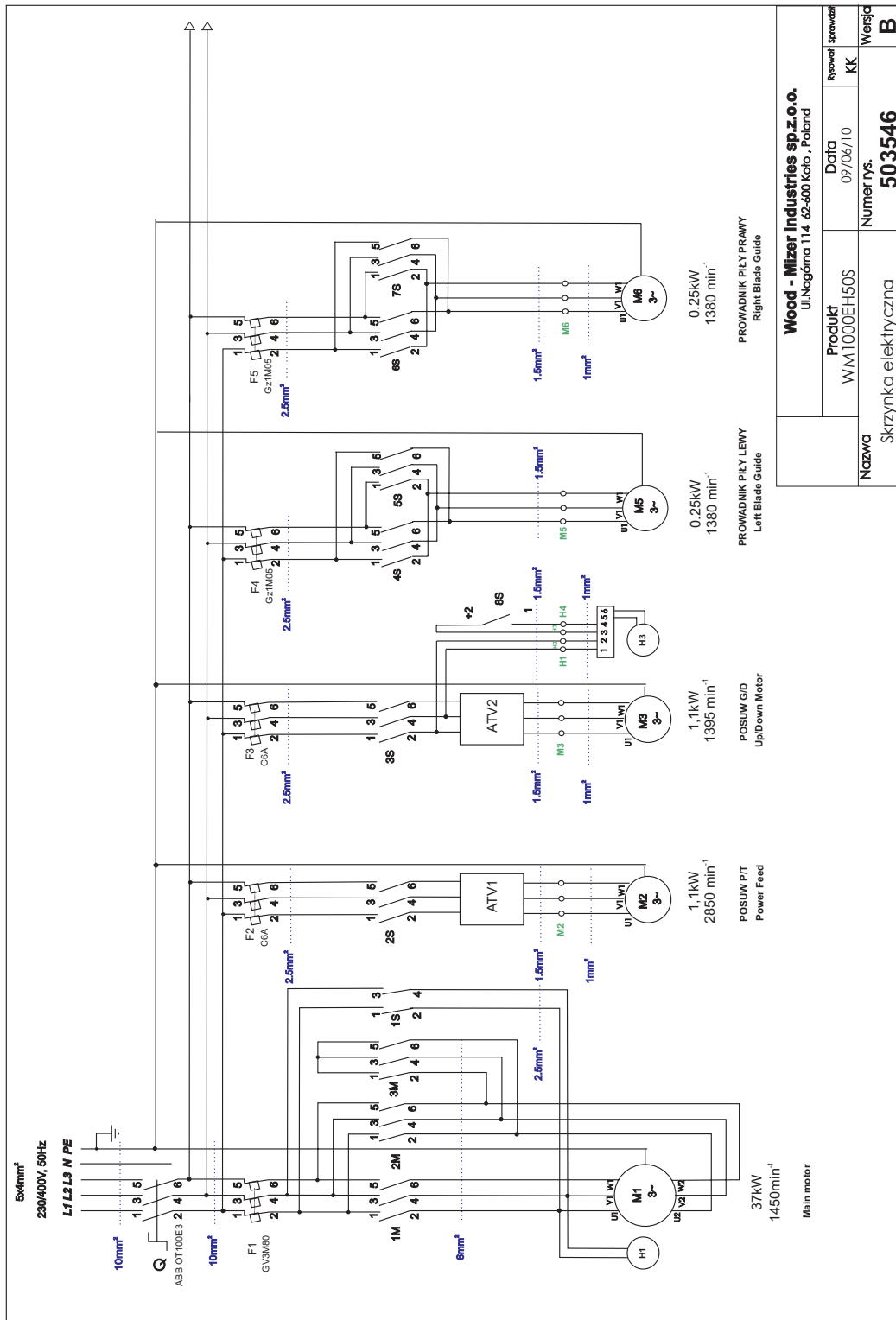

Wood - Mizer Industries sp.z.o.o. Ul. Nagłomska 114 62-600 Kob. , Poland	
Produkt WM1000EH50S	Data 09/06/10
Nazwa Skrzynka elektryczna	Numer rys. 503546
Wykonawca KK	Wersja B

FIG. 8-5 WM1000EH50S, PAGE 1

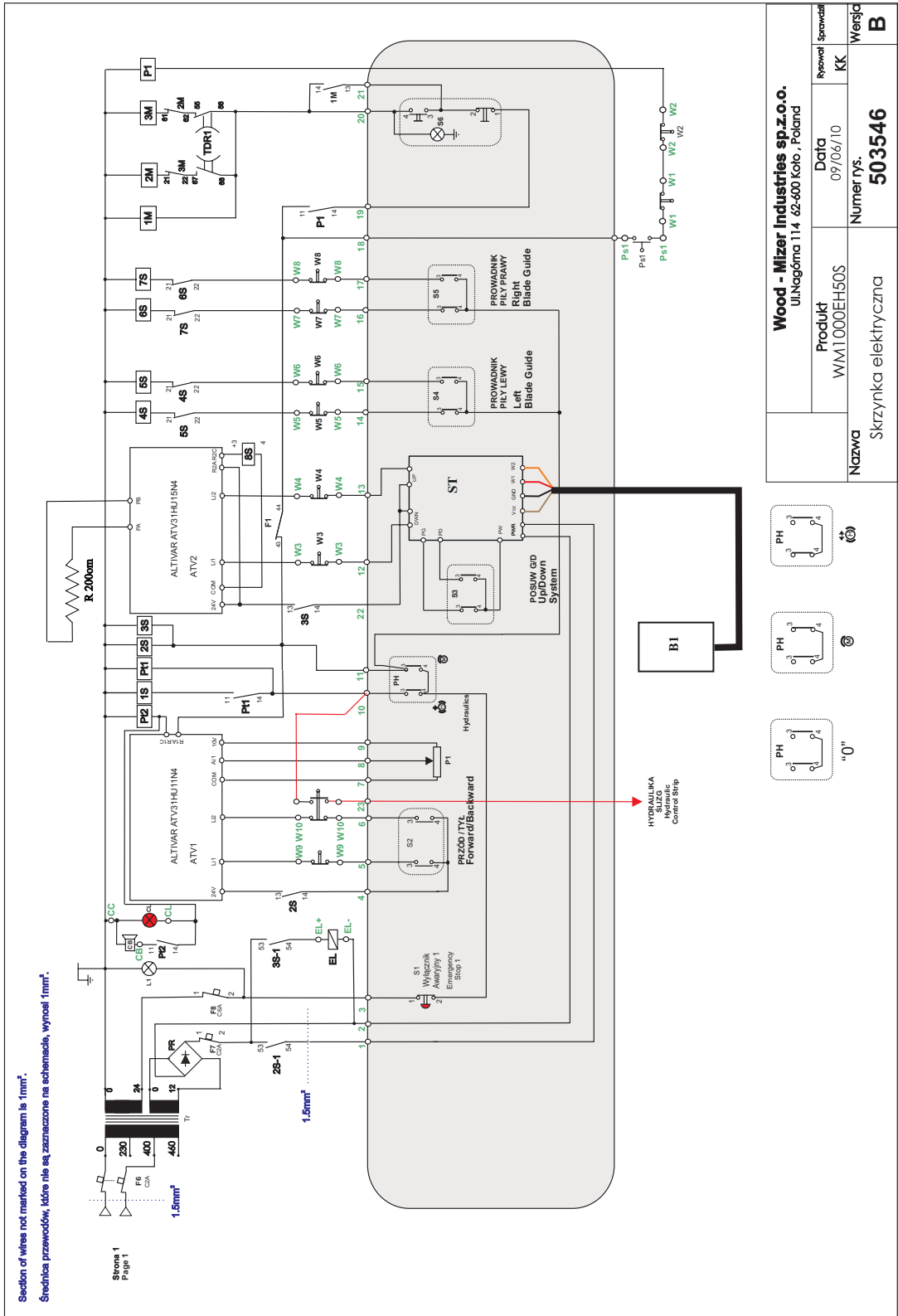

FIG. 8-6 WM1000EH50S, PAGE 2

8.6 Electrical Component List, WM1000EH50S

Symbol	Wood-Mizer Part No.	Description	Manufacturer
Q	501017	Switch, ABB OT100 F3	ABB
F1	503549	Motor Switch, GV3 M80	SCHNEIDER ELECTRIC
1M, 2M, 3M	502686	Contactor, LC1 D50 AB7	SCHNEIDER ELECTRIC
TDR1	084037	Relay, LADS2 Time	SCHNEIDER ELECTRIC
M1+H	505378	Motor, 37kW 1LG4220-4AA60-Z+G26+C01	SIEMENS
1S, 2S, 3S	084308	Contactor, LC1 K610 B7	SCHNEIDER ELECTRIC
4S, 5S, 6S, 7S	084309	Contactor, LC1 K601 B7	SCHNEIDER ELECTRIC
F2, F3	091554	Circuit Breaker, C60N 3P 6A	SCHNEIDER ELECTRIC
ATV1, ATV2	093488	Controller, ATV312HU11N4	SCHNEIDER ELECTRIC
8S	503523	Solenoid, SSR D4D07 400V 7A	CRYDOM
M2	502773	Motor, MR-63/32/0.75-1400/F3/V6 Power Feed	BESEL
M3+H3	504150	Motor, SK9032.1AZBDH-90S/4 BRE20 1,1kW Up/Down	NORD
M5, M6	100810	Motor, SKh 71-4A1 0,25kW Tray	BESEL
F4, F5	503522	Motor Switch, GZ1 M05	SCHNEIDER ELECTRIC
F6	507244	Circuit Breaker, C60N 2P 2A	SCHNEIDER ELECTRIC
F7	095842	Circuit Breaker, C60N 1P 6A	SCHNEIDER ELECTRIC
F8	088278	Circuit Breaker, C60N 1P 2A	SCHNEIDER ELECTRIC
TR	096917	Transformer, SU84A-4004601224	NORATEL
L1	090448	Control Light, M22 White	MOELLER
2S-1, 3S-1	097776	Contacts, LA1-KN22 Auxiliary	SCHNEIDER ELECTRIC
S1	086556	Switch, XB4 BS542 Emergency	SCHNEIDER ELECTRIC
PR	084318	Retifier, KBPC 3508 Bridge	-
EL	016140	Solenoid, Water Lube	PARKER
PT1, PT2	090515 090515-1 097612	Solenoid, 40.52.9.024.000 Socket, Solenoid 40.95.05 Series Time Module 86.20.0.024.0000	FINDER
R	503527	Resistor, MCRA 200W 160OHM Braking	LG
PS1	504830	Switch, Sealed F4-T-I-M3-16 BAR Hyd Pressure	SCHNEIDER ELECTRIC
W1, W2	094232	Safety Switch, AZ17-11ZRK	SCHMERSAL
W3, W4	100931	Safety Switch, GLCB01A01B	HONEYWELL
W5, W6, W7, W8, W9, W10	086469	Safety Switch, GLCB01A2B	HONEYWELL
ST	500628	Controller, SW-10 Setworks	SELBIT
B1	096014	Sensor Assy, MSK-320	SIKO
P1	E20519	Potentiometer, 1K CLA 53C3-1K	HONEYWELL S&C CLAROSTAT
PH	095001	Key Switch, M22-WRS3	MOELLER
S6	090452	START-STOP Switch, M22	MOELLER

S2	E20438	Switch, 2601AF2S12 Pwr/Feed	SCHNEIDER ELECTRIC
S3	E20440	Switch, 2601AF2S10 Up/Down	SCHNEIDER ELECTRIC
S4, S5	024000	Switch Assy, 21A DPDT	Cole Hersee Company
CL+CB	503550	Column, Red-Sound Signal	MOELLER

8.7 Electrical Diagram, WM1000EC30

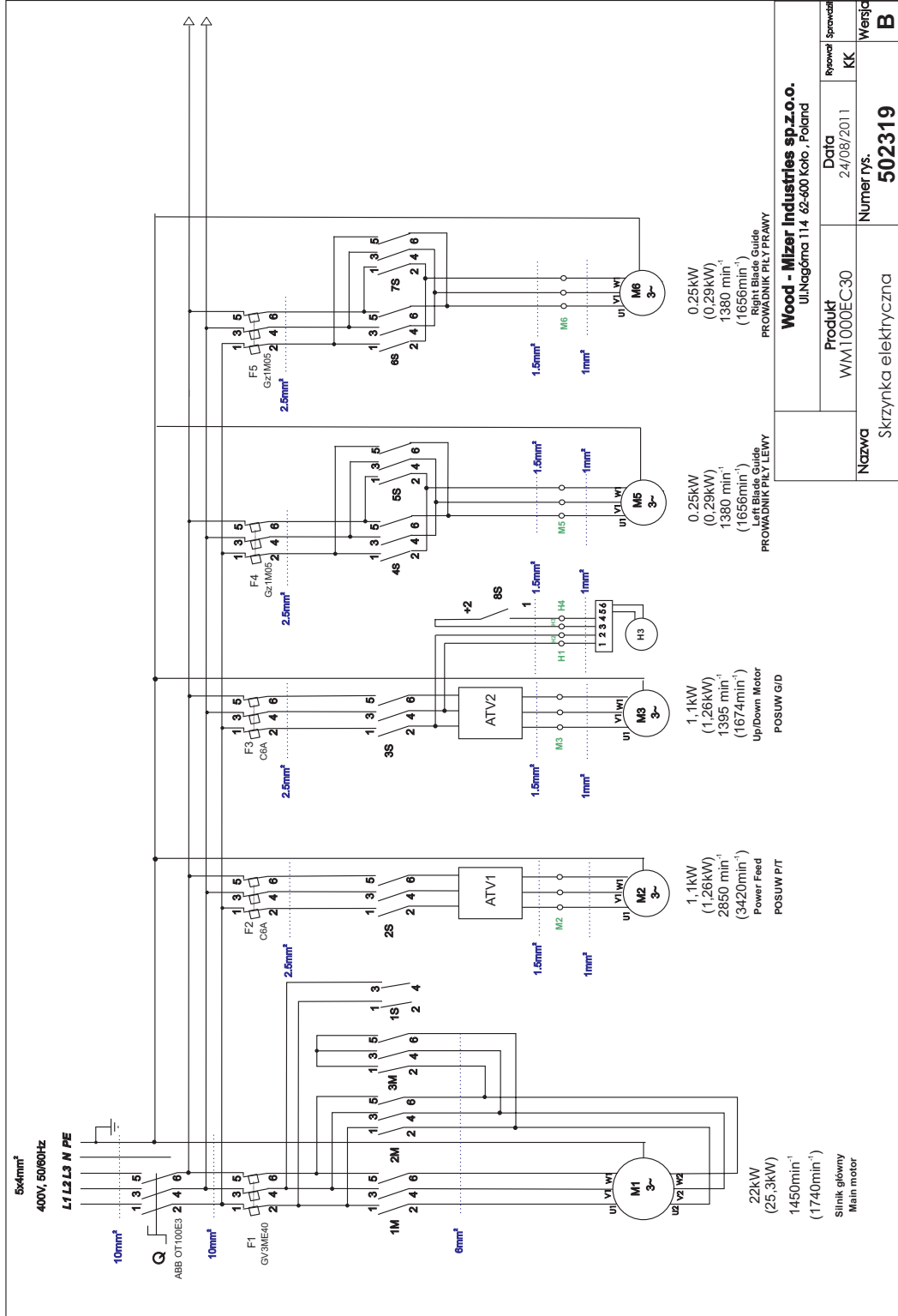

Wood - Mizer Industries sp.z o.o. Ul. Nagłomska 114 62-600 Kofo, Poland		Projekt	Sprawdzil
Produkt	WM1000EC30	Data	24/08/2011
Nazwa	Skrzynka elektryczna	Numer rys.	502319
		Wersja	B

FIG. 8-7 WM1000EC30, PAGE 1

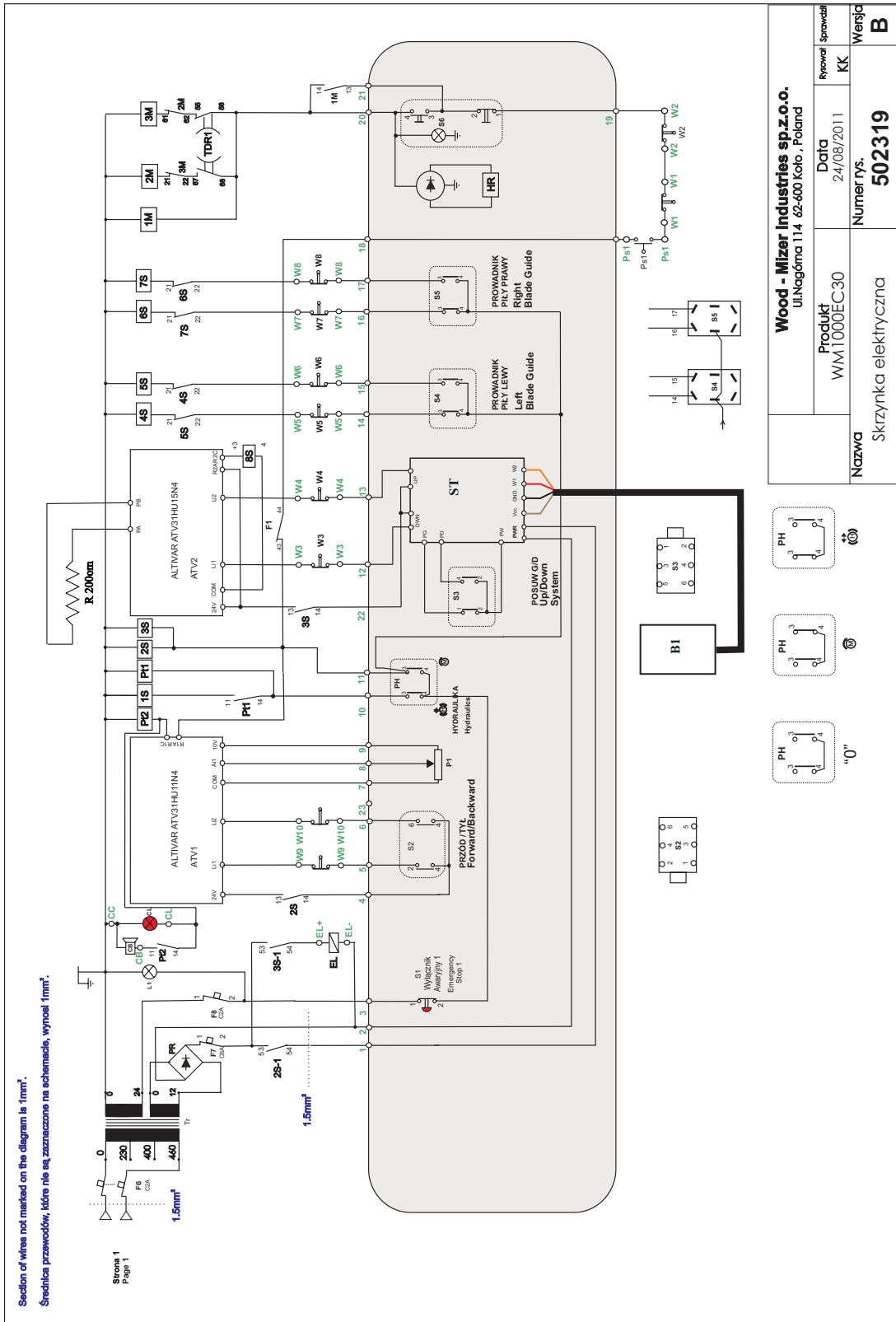

Wood - Mizer Industries sp.z.o.o. ul.Nagórna 114 62-600 Koto , Poland	
Produkt WM1000EC30	Data 24/08/2011
Nazwa Skrzynka elektryczna	Numer rys. 502319
Wykonali KK	Sprawdził Wersja B

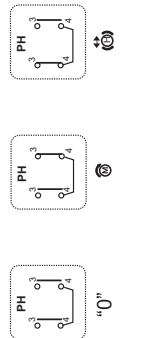

FIG. 8-8 WM1000EC30, PAGE 2

8.8 Electrical Component List, WM1000EC30

Symbol	Wood-Mizer Part No.	Description	Manufacturer
Q	501017	Switch, ABB OT100 F3	ABB
F1	090436	Motor Switch, GV3 P40	SCHNEIDER ELECTRIC
1M, 2M, 3M	090923	Contactor, LC1 D25 B7	SCHNEIDER ELECTRIC
TDR1	084037	Relay, LADS2 Time	SCHNEIDER ELECTRIC
M1	092610	Motor, 22 kW 1LG4186-4AA60	SIEMENS
1S, 2S, 3S	084308	Contactor, LC1 K610 B7	SCHNEIDER ELECTRIC
4S, 5S, 6S, 7S	084309	Contactor, LC1 K601 B7	SCHNEIDER ELECTRIC
F2, F3	091554	Circuit Breaker, C60N 3P 6A	SCHNEIDER ELECTRIC
ATV1, ATV2	093488	Controller, ATV312HU11N4	SCHNEIDER ELECTRIC
8S	503523	Solenoid, SSR D4D07 400V 7A	CRYDOM
M2	502773	Motor, MR-63/32/0.75-1400/F3/ Power Feed	BESEL
M3+H3	504150	Motor, SK9032.1AZBDH-90S/4BRE20 TF 1,1kW Up/Down	NORD
M5, M6	100810	Motor, SMR-40/21/0,25-1400/K3/V5 Tray	BESEL
F4, F5	503522	Motor Switch, GZ1 M05	SCHNEIDER ELECTRIC
F6	507244	Circuit Breaker, C60N 2P C2	SCHNEIDER ELECTRIC
F7	095842	Circuit Breaker, C60N 1P 6A	SCHNEIDER ELECTRIC
F8	088278	Circuit Breaker, C60N 1P 2A	SCHNEIDER ELECTRIC
TR	506229	Transformer, TMB200/zl.576/11	INDEL
L1	090448	Control Light, M22 White	MOELLER
2S-1, 3S-1	097776	Contacts, LA1-KN22 Auxiliary	SCHNEIDER ELECTRIC
S1	086556	Switch, XB4 BS542 Emergency	SCHNEIDER ELECTRIC
PR	084318	Retifier, KBPC 3508 Bridge	-
EL	016140	Solenoid, Water Lube	PARKER
PT1, PT2	090515 090515-1 097612	Solenoid, 40.52.9.024.000 Socket, Solenoid 40.95.05 Series Time Module 86.20.0.024.0000	FINDER
R	503527	Resistor, MCRA 200W 160OHM Braking	LG
PS1	E22726	Switch, Sealed GFW2B2 Hyd Pressure	SCHNEIDER ELECTRIC
W1, W2	094232	Safety Switch, AZ17-11ZRK	SCHMERSAL
W3, W4	100931	Safety Switch, GLCB01A01B	HONEYWELL
W5, W6, W7, W8, W9, W10	086469	Safety Switch, GLCB01A2B	HONEYWELL
ST	500628	Controller, SW-10 Setworks	SELBIT
B1	096014	Sensor Assy, MSK-320	SIKO
P1	E20519	Potentiometer, 1K CLA 53C3-1K	HONEYWELL S&C CLAROSTAT
PH	095001	Key Switch, M22-WRS3	MOELLER

S6	090452	START-STOP Switch, M22	MOELLER
S2	E20438	Switch, 2601AF2S12 Pwr/Feed	SCHNEIDER ELECTRIC
S3	E20440	Switch, 2601AF2S10 Up/Down	SCHNEIDER ELECTRIC
S4, S5	024000	Switch Assy, 21A DPDT	Cole Hersee Company
CL+CB	503550	Column, Red-Sound Signal	MOELLER

8.9 Electrical Diagram, WM1000EC50

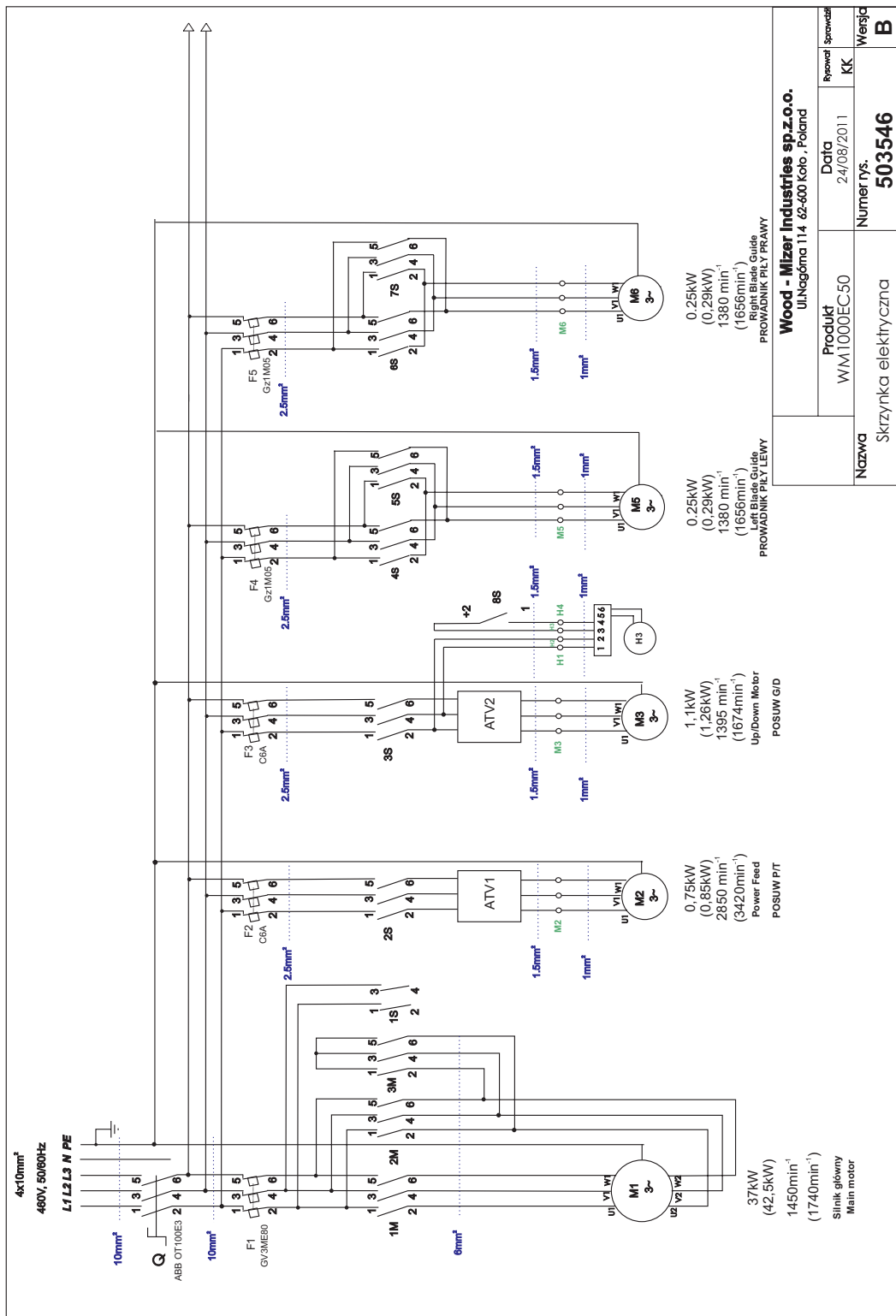

Wood - Mizer Industries sp.z.o.o. Ul. Nagólna 114 62-600 Końce, Poland	
Produkt	WM1000EC50
Data	24/08/2011
Projekt	KK
Nazwa	Skryzynka elektryczna
Numer rys.	503546
Wersja	B

FIG. 8-9 WM1000EC50, PAGE 1

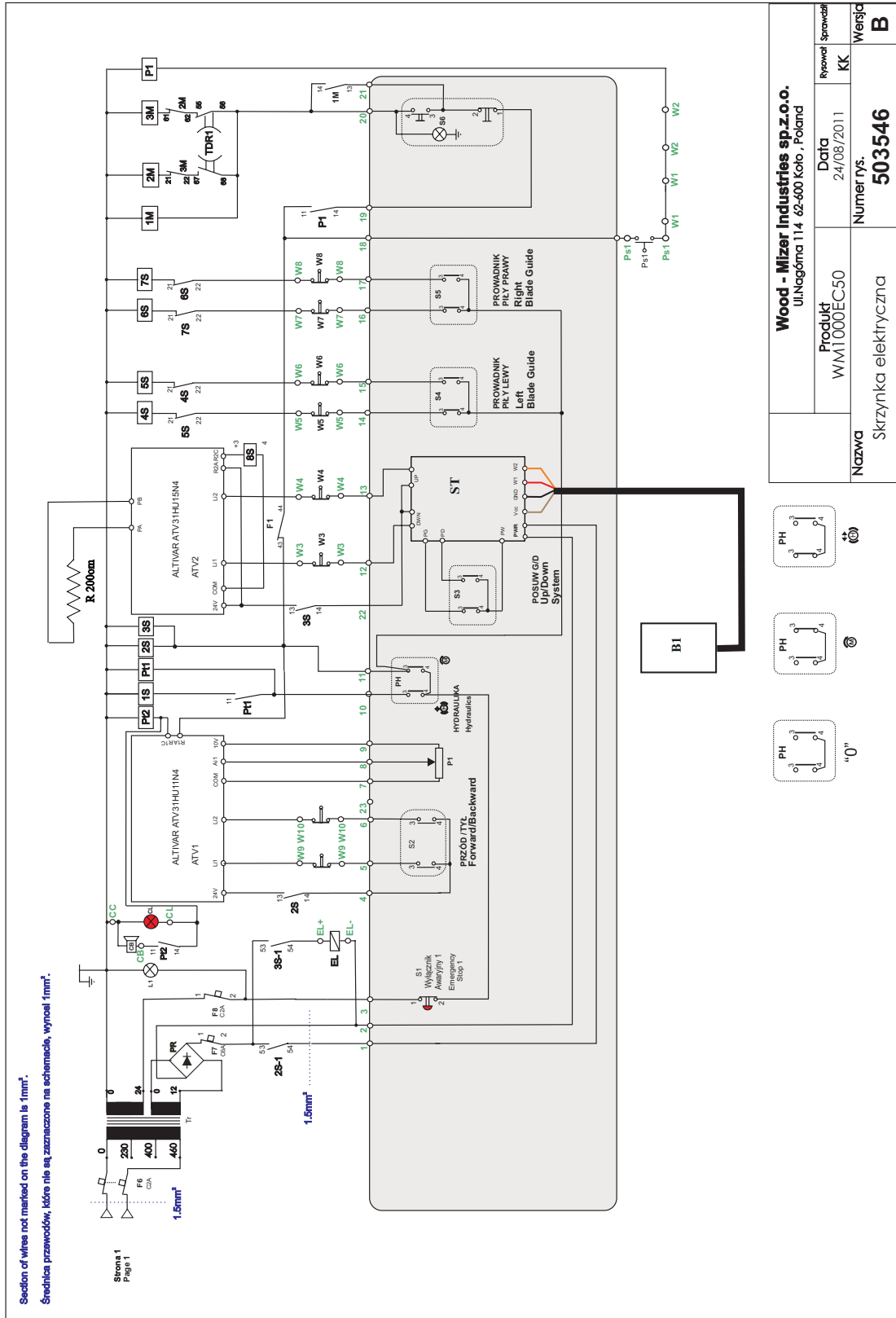

FIG. 8-10 WM1000EC50, PAGE 2

8.10 Electrical Component List, WM1000EC50

Symbol	Wood-Mizer Part No.	Description	Manufacturer
Q	501017	Switch, ABB OT100 E3	ABB
F1	503549	Motor Switch, GV3 M80	SCHNEIDER ELECTRIC
1M, 2M, 3M	502686	Contactora, LC1 D50 B7	SCHNEIDER ELECTRIC
TDR1	084037	Relay, LADS2 Time	SCHNEIDER ELECTRIC
M1	100772	Motor, 37 kW 1LG42204AA60	SIEMENS
1S, 2S, 3S	084308	Contactora, LC1 K610 B7	SCHNEIDER ELECTRIC
4S, 5S, 6S, 7S	084309	Contactora, LC1 K601 B7	SCHNEIDER ELECTRIC
F2, F3	091554	Circuit Breaker, C60N 3P 6A	SCHNEIDER ELECTRIC
ATV1, ATV2	093488	Controller, ATV312HU11N4	SCHNEIDER ELECTRIC
8S	503523	Solenoid, SSR D4D07 400V 7A	CRYDOM
M2	502773	Motor, MR-63/32/0.75-1400/F3/V6 Power Feed	BESEL
M3+H3	504150	Motor, SK9032.1AZBDH-90S/4BRE20 1,1kW Up/Down	NORD
M5, M6	100810	Motor, MR-40/21/0,25-1400/K3/V5 0,25kW Tray	BESEL
F4, F5	503522	Motor Switch, GZ1 M05	SCHNEIDER ELECTRIC
F6	507244	Circuit Breaker, C60N 2P 2A	SCHNEIDER ELECTRIC
F7	095842	Circuit Breaker, C60N 1P 6A	SCHNEIDER ELECTRIC
F8	088278	Circuit Breaker, C60N 1P 2A	SCHNEIDER ELECTRIC
TR	506229	Transformer, TMB200/zl.576/11	INDEL
L1	090448	Control Light, M22 White	MOELLER
2S-1, 3S-1	097776	Contacts, LA1-KN22 Auxiliary	SCHNEIDER ELECTRIC
S1	086556	Switch, XB4 BS542 Emergency	SCHNEIDER ELECTRIC
PR	084318	Rectifier, KBPC 3508 Bridge	-
EL	016140	Solenoid, Water Lube	PARKER
PT1, PT2	090515 090515-1 097612	Solenoid, 40.52.9.024.000 Socket, Solenoid 40.95.05 Series Time Module 86.20.0.024.0000	FINDER
P1	090515	Solenoid, 40.52.9.024.00.00	FINDER
R	503527	Resistor, MCRA 200W 160OHM Braking	LG
PS1	504830	Switch, Sealed F4-T-I-M3-16 BAR.Hyd Pressure	SCHNEIDER ELECTRIC
W1, W2	094232	Safety Switch, AZ17-11ZRK	SCHMERSAL
W3, W4	100931	Safety Switch, GLCB01A01B	HONEYWELL
W5, W6, W7, W8, W9, W10	086469	Safety Switch, GLCB01A2B	HONEYWELL
ST	500628	Controller, SW-10 Setworks	SELBIT
B1	096014	Sensor Assy, MSK-320	SIKO
P1	E20519	Potentiometer, 1K CLA 53C3-1K	HONEYWELL S&C CLAROSTAT
PH	095001	Key Switch, M22-WRS3	MOELLER

S6	090452	START-STOP Switch, M22	MOELLER
S2	E20438	Switch, 2601AF2S12 Pwr/Feed	SCHNEIDER ELECTRIC
S3	E20440	Switch, 2601AF2S10 Up/Down	SCHNEIDER ELECTRIC
S4, S5	024000	Switch Assy, 21A DPDT	Cole Hersee Company
CL+CB	503550	Column, Red-Sound Signal	MOELLER

EC declaration of conformity according to EC Machinery Directive 2006/42/EC

We herewith declare,

Wood-Mizer Industries sp. Z O.O.
114 Nagorna street, 62-600 Kolo; Poland.

That the following described machine in our delivered version complies with the appropriate basic safety and health requirements of the EC Machinery Directive 2006/42/EC based on its design and type, as brought into circulation by us. In case of alteration of the machine, not agreed by us, this declaration is no longer valid.

Designation of the machine:	Sawmill
TYPE:	WM1000S
No. of manufacturer:
Applicable EC Directives:	EC Machinery Directive 2006/42/EC EC Low-Voltage Directive 2006/95/EC EC Electromagnetic Compatibility Directive 2004/108/EC
Applicable Harmonized Standards:	EN 1807-2:2009 EN 60204-1/A1:2009
Notified Body according to annex IV :	TUV SUD Product Service GmbH Gottlieb-Daimler Strasse 7 70794 Filderstadt
Notification No	0123
Responsible for:	EC type examination
EC type-examination certificate no.	M8A110855286021
Responsible for Technical Documentation:	Roman Frontczak / R&D Director
Date/Authorized Signature:	18. 08. 2011 
Title:	R&D Director