

Wood-Mizer®

Parts Manual

LT20 B1-4 E15S MH	rev. A6.00
LT20 B1-4 D22S MH	rev. A6.00
LT20 B1-4 G25S MH	rev. A6.00



Safety is our #1 concern! Read and understand all safety information and instructions before operating, setting up or maintaining this machine.

October 2008

Form #632

Table of Contents

Section-Page

SECTION 1	GENERAL INFORMATION	1-1
1.1	How To Use The Parts List	1-1
1.2	Sample Assembly	1-1
SECTION 2	BLADE GUIDE ROLLERS & ARM	2-1
2.1	Blade Guide Assembly, Idle Side.....	2-1
2.2	Blade Guide Assembly, Drive Side.....	2-2
2.3	Blade Guide Arm & Rollers	2-3
2.4	Blade Guide Arm Drive Assembly.....	2-4
SECTION 3	BLADE WHEELS & TENSIONER	3-1
3.1	Blade Wheel Assembly, Drive Side	3-1
3.2	Blade Wheel Assembly, Idle Side	3-2
3.3	Blade Tensioner Assembly	3-3
SECTION 4	SAW HEAD	4-1
4.1	Middle Throat Screw	4-1
4.2	Drive Belt Tensioner, DC Sawmills	4-1
4.3	Water Lube Assembly	4-3
4.4	Blade Lube System.....	4-4
4.5	LT20AC Saw Head Decals	4-5
4.6	LT20DC Saw Head Decals	4-7
4.7	Blade Housing Cover	4-9
4.8	Control Box (AC Sawmills)	4-11
4.9	Control Box (DC Sawmills)	4-13
4.10	Drum Switches	4-15
4.11	Sawdust Chute	4-16
4.12	Up/Down Cable Chain Assembly	4-17
4.13	LES Control Box Bracket.....	4-18
4.14	Saw Head Safety Device For LT20B Sawmills	4-19
SECTION 5	UP/DOWN ASSEMBLY	5-1
5.1	Up/Down Assembly, AC Mills	5-1
5.2	Up/Down Assembly, DC Mills	5-3
5.3	Up/Down Chain Tensioner Assembly.....	5-5
5.4	Battery Box Assembly, DC Mills.....	5-6

Table of Contents

Section-Page

SECTION 6 UP/DOWN ROLLERS & BLADE HEIGHT SCALE

6-1

6.1	Up/Down Rollers.....	6-1
6.2	Blade Height Scale	6-3
6.3	Limit Switches.....	6-5

SECTION 7 POWER FEED & TRACK ROLLERS

7-1

7.1	Power Feed Assembly, AC Mills	7-1
7.2	Power Feed Assembly, DC Mills	7-3
7.3	Upper Track Rollers And Wipers	7-5
7.4	Lower Track Rollers	7-7

SECTION 8 BED FRAME ASSEMBLY

8-1

8.1	Bed Section.....	8-1
8.2	Bed Section, Additional	8-2
8.3	Bed Extension.....	8-3
8.4	Stationary Leg Kit	8-4
8.5	Outrigger Leg Kit	8-5
8.6	Outrigger Leg Kit High - LES B3	8-6
8.7	Log Side Support Assembly	8-7
8.8	Front & Rear Tubes	8-8
8.9	Bumpers.....	8-9
8.10	Remote Equipment Option	8-10
8.11	Bed Frame Decals.....	8-11
8.12	Saw Head Transportation Holder, LT70B.....	8-12

SECTION 9 LOG CLAMP, LOADING RAMP & TOE BOARD

9-1

9.1	Log Clamp, LES	9-1
9.2	Loading Ramp	9-2
9.3	Manual Toe Board.....	9-3
9.4	H1/H2/H3 Control Assemblies - Options.....	9-4
9.5	Toe Board Roller Option	9-7
9.6	Roller Turner Option	9-9
9.7	Winch Option	9-11
9.8	Log Side Supports w/Lever Option.....	9-12

SECTION 1 GENERAL INFORMATION

1.1 How To Use The Parts List

- Use the index above to locate the assembly that contains the part you need.
- Go to the appropriate section and locate the part in the illustration.
- Use the number pointing to the part to locate the correct part number and description in the table.
- Parts shown indented under another part are included with that part.
- Parts marked with a diamond (◆) are only available in the assembly listed above the part.

See the sample table below. Sample Part #A01111 includes part F02222-2 and subassembly A03333. Subassembly A03333 includes part S04444-4 and subassembly K05555. The diamond (◆) indicates that S04444-4 is not available except in subassembly A03333. Subassembly K05555 includes parts M06666 and F07777-77. The diamond (◆) indicates M06666 is not available except in subassembly K05555.

1.2 Sample Assembly				
REF	DESCRIPTION (◆ Indicates Parts Available In Assemblies Only)	PART #	QTY.	
	Sample Assembly, Complete (Includes All Indented Parts Below)	A01111	1	
1	Sample Part	F02222-22	1	
	Sample Subassembly (Includes All Indented Parts Below)	A03333	1	
2	Sample Part (◆ Indicates Part Is Only Available With A03333)	S04444-4	1	◆
	Sample Subassembly (Includes All Indented Parts Below)	K05555	1	
3	Sample Part (◆ Indicates Part Is Only Available With K05555)	M06666	2	◆
4	Sample Part	F07777-77	1	

To Order Parts:

- From Europe call our European Headquarters and Manufacturing Facility in Kolo, Poland at **+48-63-2626000**. From the continental U.S., call our toll-free Parts hotline at **1-800-525-8100**. Have your customer number, vehicle identification number, and part numbers ready when you call. From other international locations, contact the Wood-Mizer distributor in your area for parts.

Office Hours:

Country	Monday - Friday	Saturday	Sunday
Poland	7-15	Closed	Closed
US	8 a.m.- 5 a.m.	8 a.m.- 12 p.m.	Closed



CAUTION! It is strongly recommended that only original spare parts be used.

SECTION 2 BLADE GUIDE ROLLERS & ARM

2.1 Blade Guide Assembly, Idle Side

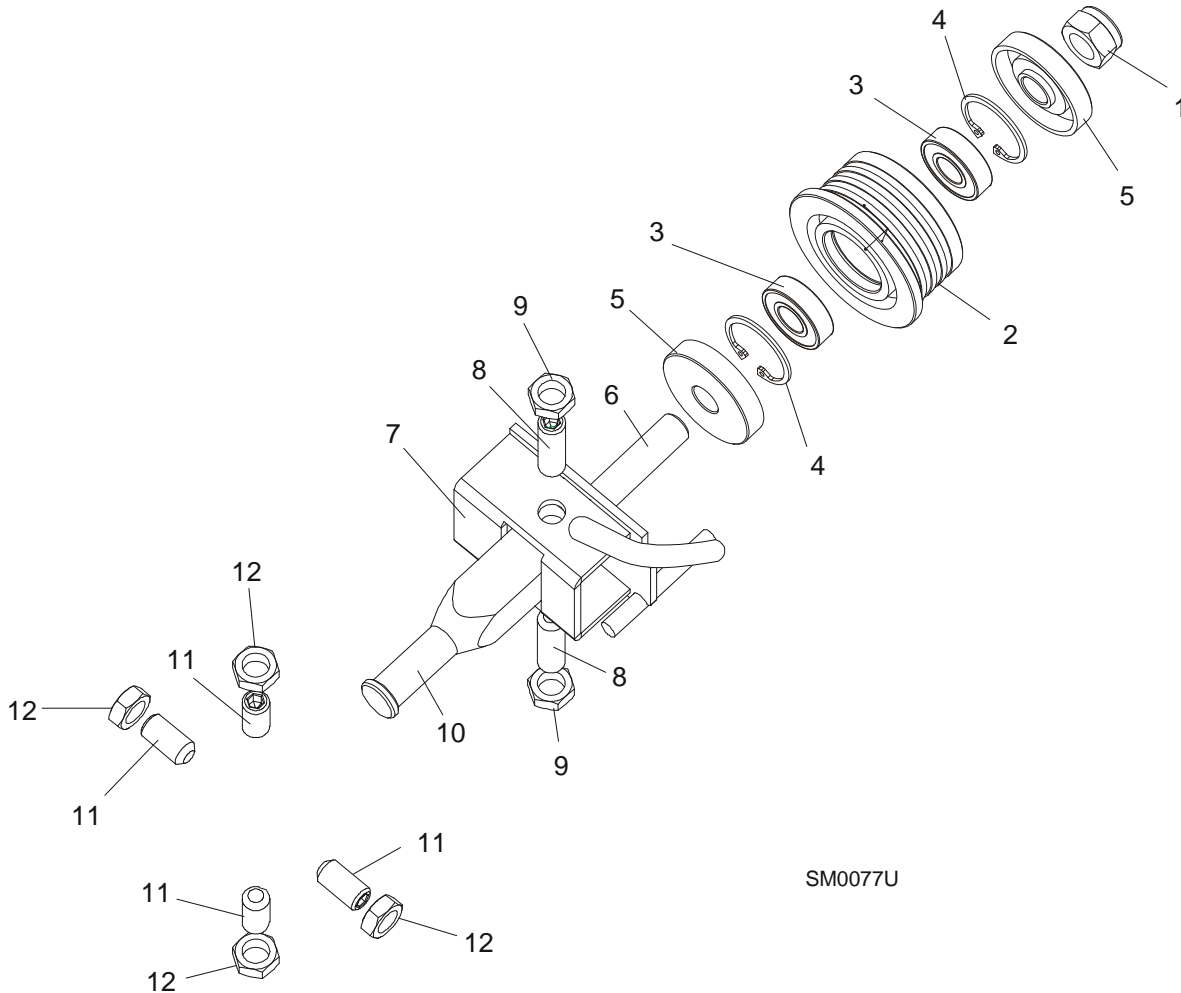

SM0077U

REF.	DESCRIPTION (◆ Indicates Parts Available In Assemblies Only)	PART #	QTY.	
	BLADE GUIDE ASSEMBLY, IDLE SIDE	094683	1	
	Roller, Blade Guide Complete Standard	087887	1	
1	Nut, M12-8 Hex Nylon Zinc Lock	F81034-2	1	
2	Roller, Blade Guide Narrow	087889	1	◆
3	Bearing, 6001 2RSR FAG	087893	2	
4	Ring, W28 Inside Retaining	F81090-9	1	
5	Washer, Zinc-plated Spacer	087891-1	2	
6	Shaft, Blade Guide Roller Zinc-plated	087763-1	1	
7	Bracket Weldment, Idle Side Blade Guide Painted	094681-1	1	
8	Screw, M10x1x40 DIN 913 A2-70 Set Stainless Steel	F81015-2	2	
9	Nut, M10x1-04-ST-A2 ISO 8675 Thin	F81033-10	2	
10	Shaft, Blade Guide Mount Zinc-plated	503588-1	1	
11	SCREW, M10X1X20 DIN 913 SET STAINLESS STEEL	F81015-1	4	
12	NUT, M10x1-04-ST-A2 ISO 8675 THIN	F81033-10	4	

2

Blade Guide Rollers & Arm

Blade Guide Assembly, Drive Side

2.2 Blade Guide Assembly, Drive Side

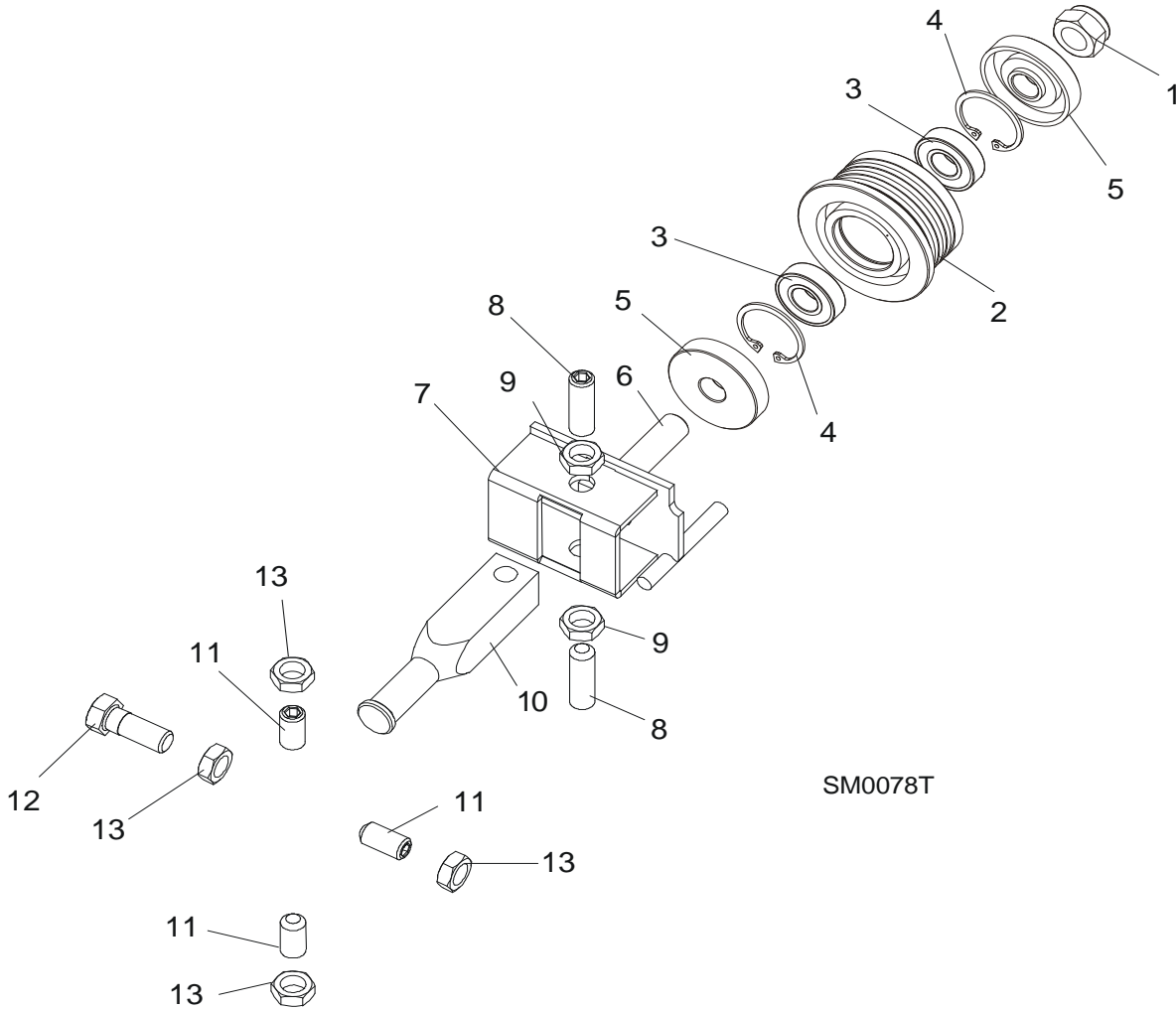

SM0078T

REF.	DESCRIPTION (◆ Indicates Parts Available In Assemblies Only)	PART #	QTY.
	BLADE GUIDE ASSEMBLY, DRIVE SIDE	094682	1
	Roller, Blade Guide Complete Standard	087887	1
1	Nut, M12-8 Hex Nylon Zinc Lock	F81034-2	1
2	Roller, Blade Guide Narrow	087889	1 ◆
3	Bearing, 6001 2RSR FAG	087893	2
4	Ring, W28 Inside Retaining	F81090-9	1
5	Washer, Zinc-plated Spacer	087891-1	2
6	Shaft, Blade Guide Roller Zinc-plated	087763-1	1
7	Bracket Weldment, Blade Guide Painted	094679-1	1
	Screw Kit, Blade Guide Adjustment w/Nuts (for two blade guide assemblies)	K09942	1
8	Screw, M10x1x40 DIN 913 A2-70 Set Stainless Steel	F81015-2	2
9	Nut, M10x1-04-ST-A2 ISO 8675 Thin	F81033-10	2
10	Shaft, Blade Guide Mount Zinc-plated	503588-1	1
11	SCREW, M10X1X20 DIN 913 SET STAINLESS STEEL	F81015-1	3
12	BOLT, M10X1X25 DIN 933 STAINLESS STEEL	F81003-28	1

13	NUT, M10x1-04-ST-A2 ISO 8675 THIN	F81033-10	4
----	-----------------------------------	-----------	---

2.3 Blade Guide Arm & Rollers

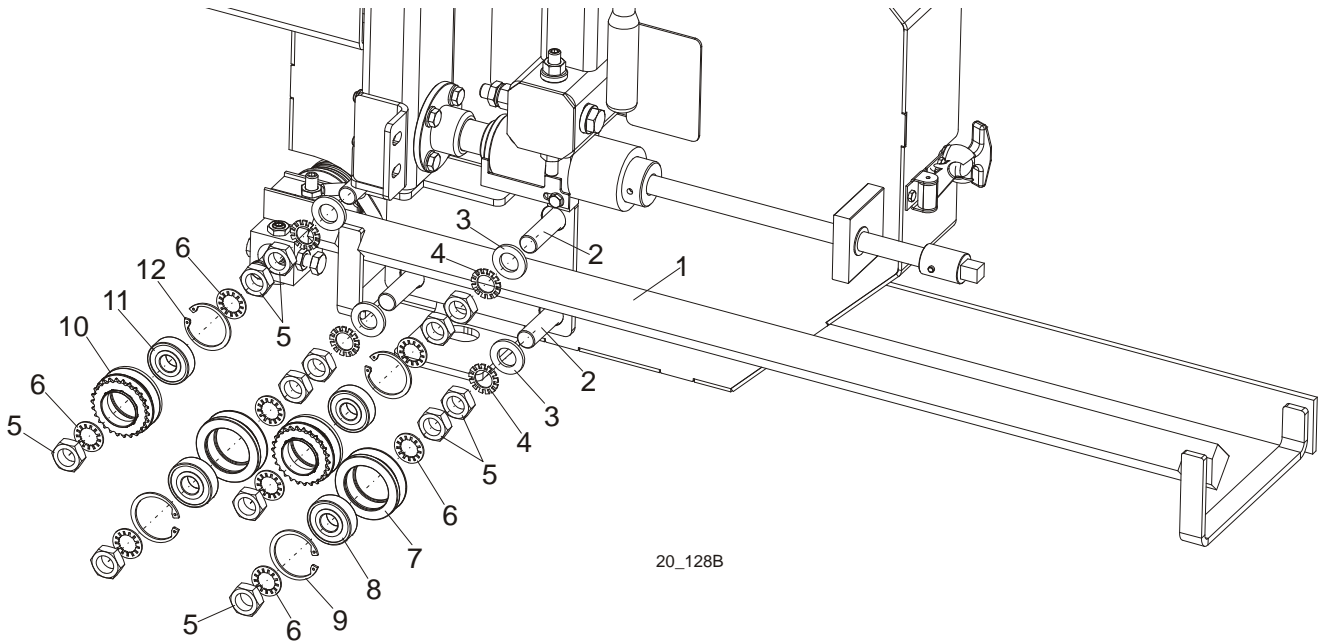

REF.	DESCRIPTION (◆ Indicates Parts Available In Assemblies Only)	PART #	QTY.
1	BLADE GUIDE ARM WELDMENT	096397-1	1
2	BOLT, BLADE GUIDE ARM ROLLER CAM	086508-1	4
3	WASHER, M16,FLAT ZINC	F81058-1	4
4	WASHER, 5/8" EXTERNAL STAR	F05011-26	4
5	NUT, 5/8-18 HEX JAM	F05010-11	12
6	WASHER, 5/8" INTERNAL STAR	F05011-25	8
	ROLLER ASSY, BLADE GUIDE ARM WITH BEARING	093855	2
7	Roller, Blade Guide Arm V-Groove	093856-1	1 ◆
8	Bearing, 6203 2RSP6-5/8 CX	095087	1
9	Ring, W40 Retaining	F81090-3	1
	ROLLER ASSY, BLADE GUIDE ARM DRIVE W/SPROCKET COMPLETE	501496	2
10	Roller, Blade Guide Arm Drive w/Sprocket	501495-1	1 ◆
11	Bearing, 6203-2 RSP6-5/8 CX	095087	1
12	Ring, W40 Spring Retaining	F81090-3	1

2.4 Blade Guide Arm Drive Assembly

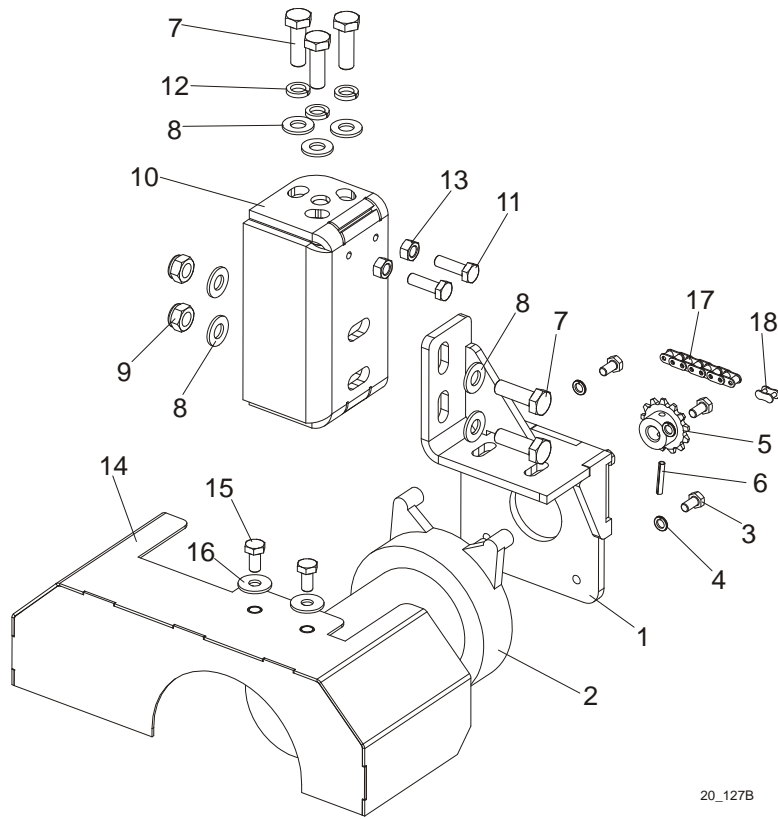

20_127B

REF.	DESCRIPTION (◆ Indicates Parts Available In Assemblies Only)	PART #	QTY.
	DRIVE ASSEMBLY, BLADE GUIDE ARM	096396	1
1	BRACKET, BLADE GUIDE ARM MOTOR MOUNT	096390-1	1
2	MOTOR, BLADE GUIDE ARM 53:1 GEAR	P09698-1	1
3	SCREW, 10-32X1/2 HH MACHINE	F05004-60	4
4	WASHER, 5.1 SPLIT LOCK	F81052-2	4
5	SPROCKET, 25B13X.3130	P09970	1
6	PIN, 1/8X3/4 ROLL	F05012-6	1
7	BOLT, M8x25-8.8-B HEX HEAD FULL THREAD ZINC	F81002-5	5
8	WASHER, 8.4 FLAT ZINC	F81054-1	7
9	NUT, M8-8-B HEX NYLON ZINC LOCK	F81032-2	2
10	BRACKET, BLADE GUIDE ARM DRIVE	501265-1	1
11	BOLT, M6x20-8.8 HEX HEAD FULL THREAD ZINC	F81001-2	2
12	WASHER, 8.2 SPLIT LOCK	F81054-4	3
13	NUT, M6-8.8 HEX GRADE 5 ZINC	F81031-1	2
14	COVER, LT20 BLADE GUIDE ARM MOTOR	097424-1	1
15	BOLT, M6X12MM HEX HEAD ZINC	F81001-7	2
16	WASHER, 6.5 FLAT ZINC	F81053-11	2
17	CHAIN, 20 1/4IN #25	P09984	1
18	LINK, 25 MASTER	P09983	1

SECTION 3 BLADE WHEELS & TENSIONER

3.1 Blade Wheel Assembly, Drive Side

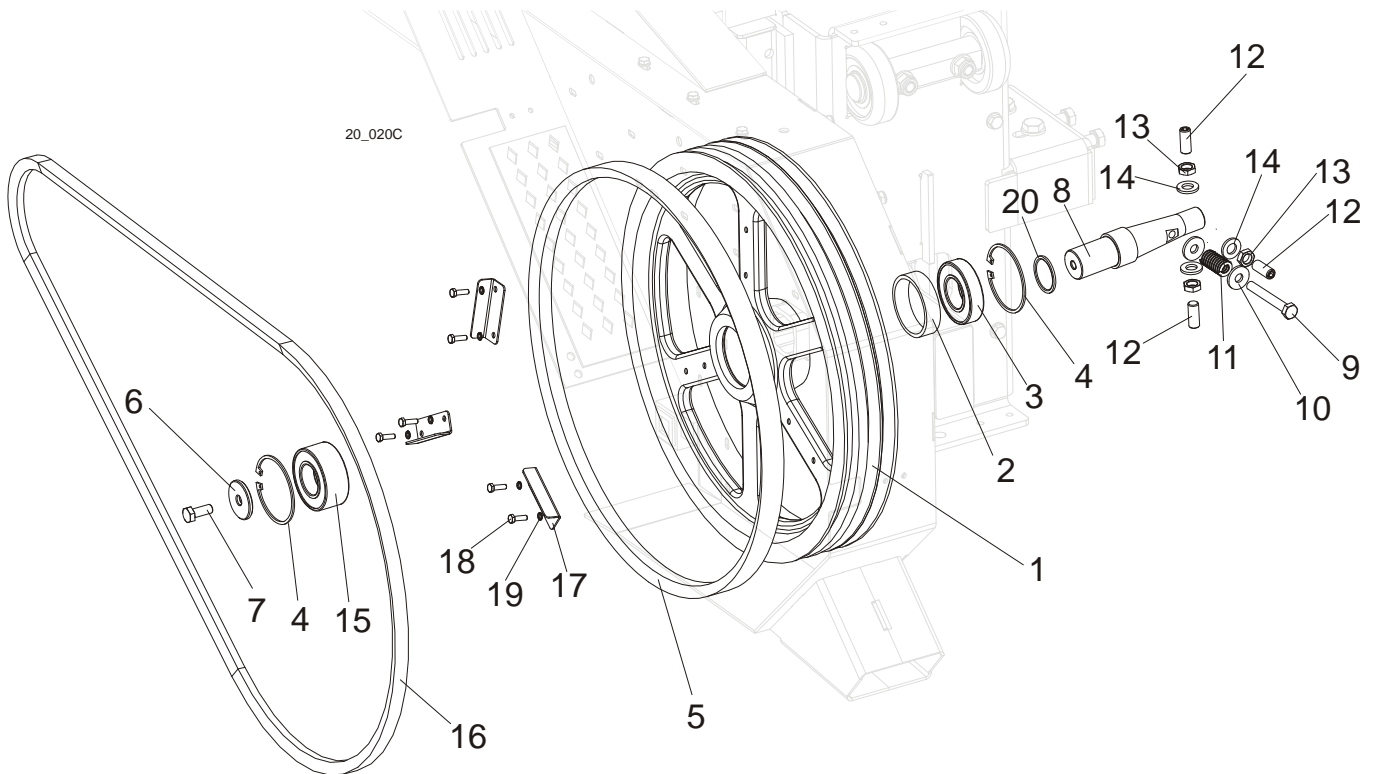

REF.	DESCRIPTION (◆ Indicates Parts Available In Assemblies Only)	PART #	QTY.
	BLADE WHEEL ASSEMBLY, LT20 DRIVE SIDE	091612	1
1	Wheel, LT20 Drive Side Blade	090646-1	1
2	Bushing, Bearing Spacer	096778	1
3	Bearing, 6207 2RS 35x72x17 FAG	014811	1
4	Ring, W72 Retaining	F81090-4	2
5	Belt, B57 Blade Wheel	P04185-2	1
6	Washer, Drive Side Blade Wheel	092006	1
7	Bolt, M10x25-8.8 Hex Head Full Thread Zinc	F81003-11	1
8	Shaft, LT15/20 Drive Side Blade Wheel	093850	1
9	Bolt, M10X65-8.8-B Hex Head Zinc	F81003-67	1
10	Washer, Zinc	098813-1	2
11	Spring, 19x38 Compression	034430	1
12	Screw, M12x1,25x30 DIN913 Set	F81016-1	4
13	Washer, 13 Flat Zinc	F81056-1	4
14	Nut, M12x1,25 DIN439 Thin Stainless Steel	F81034-9	4
15	Bearing, 3207B, 2RSR. TVH FAQ	092005	1
16	Drive Belt, 2BX81, AC Sawmills (E11, E15) Drive Belt, 2BX84, DC Sawmills (D17, D22 & G25)	014819-2 (AC) 088110 (DC)	1 2
17	Wing	097808-1	3
18	Bolt, M6x20mm, HH, Full Thread, Zinc	F81001-2	6
19	Washer, M6 Split Lock Zinc	F81053-3	6
20	Washer, φ35 Special	091851	1

3.2 Blade Wheel Assembly, Idle Side

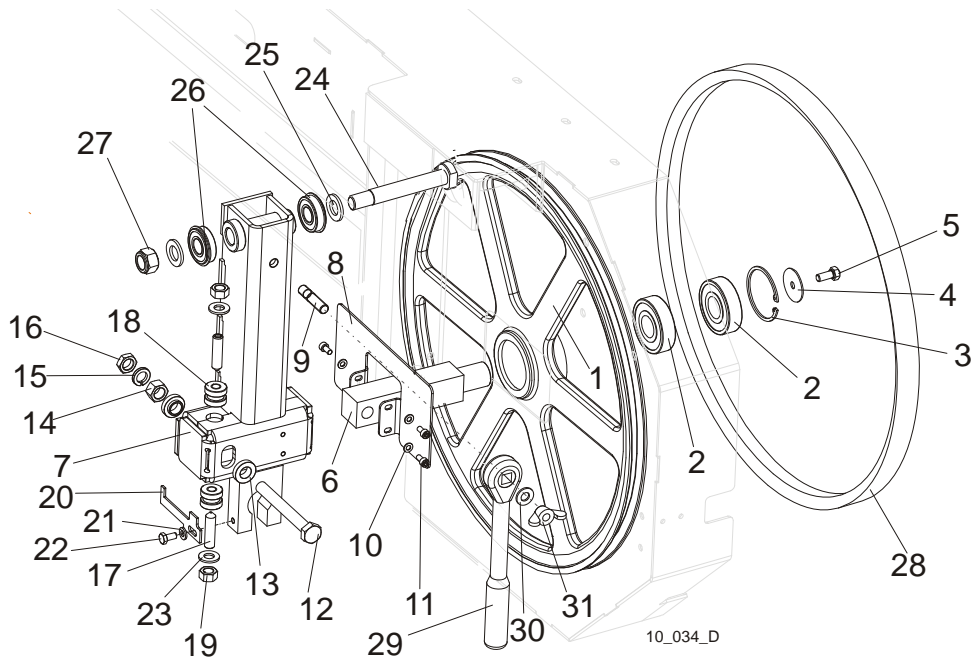

REF.	DESCRIPTION (◆ Indicates Parts Available In Assemblies Only)	PART #	QTY.
	WHEEL ASSEMBLY, IDLE SIDE BLADE	A08218	1
1	WHEEL ASSEMBLY, 18.62" BLADE IDLE SIDE	P08125	1
2	BEARING, 6305 2RS NSK IDLE SIDE WHEEL	P08066	2
3	RING, 2 7/16" INSIDE RETAINING	F04254-21	1
	HOUSING, LT10 & LT15 IDLER SHAFT, COMPLETE	100180	1
4	WASHER, IDLE SIDE WHEEL RETAINING	093854-1	1
5	BOLT, M8X25-8.8-B HEX HEAD FULL THREAD ZINC	F81002-5	1
6	SHAFT, IDLE SIDE BLADE WHEEL (METRIC)	096045	1
	HOUSING, IDLER SHAFT COMPLETE	508145	1
7	HOUSING, IDLER SHAFT WELDED/PAINTED	508144-1	1
8	COVER, HOUSING, IDLER SHAFT COMPLETE PAINTED	508128-1	1
9	BOLT M10X35-8.8	F81003-9	1
10	WASHER, 5.3 FLAT ZINC	F81052-1	3
11	SCREW, M5x10 DIN912 A2-70 HEX SOCKET HEAD	F81000-23	3
12	BOLT, M12X1,25X100-8.8 HEX HEAD FULL THREAD ZINC	F81004-41	1
13	WASHER, FLANGED ZINC-PLATED	086769-1	2
14	NUT, M12X1,25 -8 HEX ZINC	F81034-8	1
15	WASHER, 12.2 SPLIT LOCK ZINC	F81056-2	1
16	NUT, M12x1.25 DIN439 THIN STAINLESS STEEL	F81034-5	1
17	SCREW, M10X40-45H CONE POINT HEX SOCKET	F81003-61	2
18	BUSHING, M10 IDLER SHAFT HOUSING	086987	2
19	NUT, M10-8-B HEX HEAD ZINC	F81033-3	2
20	INDICATOR, LT15/LT20 PTD BLADE TENSION	092467-1	1
21	WASHER, 6.4 FLAT ZINC	F81053-1	1
22	BOLT, M6x12-8.8 HEX HEAD FULL THREAD ZIN	F81001-7	1
23	WASHER, 10.5 FLAT ZINC	F81055-1	2
24	PIN, IDLER ARM MOUNT	086404	1

25	WASHER, 17 FLAT ZINC	F81058-1	2	
26	BEARING, 6203-2RS NR NSK W/SNAP RING	086395	2	
27	NUT, M16-8 HEX NYLON ZINC LOCK	F81036-2	1	
28	V-BELT, B57	P04185-2	1	
29	WRENCH, LT20 BLADE TENSION	091620	1	
30	WASHER, 10.5 FLAT ZINC	F81055-1	1	
31	NUT WING M10	F81033-8	1	

3.3 Blade Tensioner Assembly

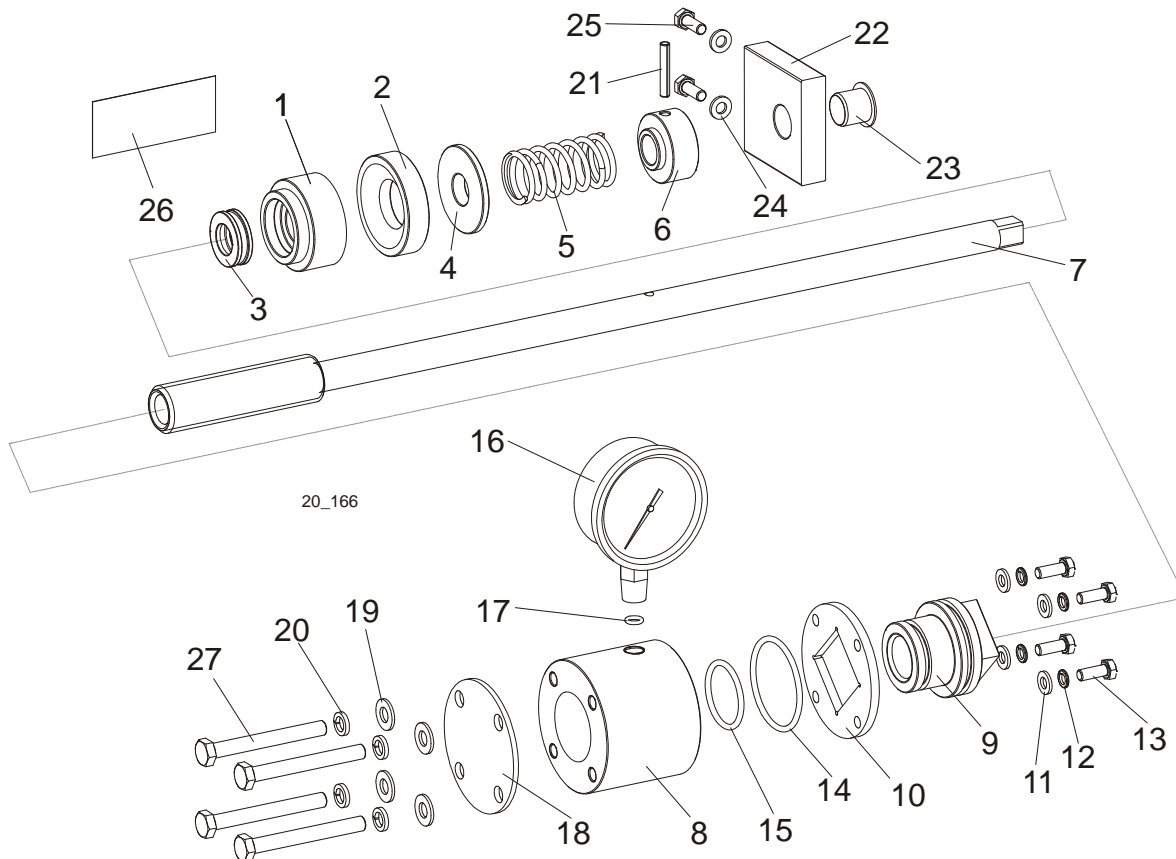

REF.	DESCRIPTION (◆ Indicates Parts Available In Assemblies Only)	PART #	QTY.	
	COMPLETE BLADE TENSIONER	510640	1	
1	HOUSING, BALL THRUST BEARING	510635	1	
2	SOCKET, BEARING HOUSING	510634-1	1	
3	BEARING, 51103. BALL THRUST	086675	1	
4	WASHER	510633-1	1	
5	SPRING, n3mm	088992	1	
6	BUSHING, BLADE TENSIONER SCREW	510636-1	1	
7	SCREW, BLADE TENSIONER ZINC-PLATED	510650-1	1	
	CYLINDER ASSEMBLY	510641	1	
8	CYLINDER	510637-1	1	
9	PISTON	510638	1	
10	PLATE, CYLINDER	510490-1	1	
11	WASHER, 6.4 FLAT ZINC	F81053-1	4	
12	WASHER, Z 6.1 SPLIT LOCK ZINC	F81053-3	4	

3

Blade Wheels & Tensioner*Blade Tensioner Assembly*

13	BOLT, M6x16-8.8 HEX HEAD FULL THREAD ZINC	F81001-15	4	
14	O-RING, 46.2x3	510646	1	
15	O-RING, 32.2x3	510647	1	
16	GAUGE, 3000psi/200 bar OIL PRESSURE	505176	1	
17	O-RING, 6.2x2	510648	1	
18	PLATE, CYLINDER COVER	510642-1	1	
19	WASHER, 8.4 FLAT ZINC	F81054-1	4	
20	WASHER, 8.2 SPLIT LOCK ZINC	F81054-4	4	
21	PIN, 5x30 ROLL ZINC	F81044-21	1	
22	BLOCK, TENSIONER HANDLE MOUNT	096730	1	
23	BUSHING, GFM-1618-17	089589	1	
24	WASHER, 6.4 FLAT ZINC	F81053-1	2	
25	BOLT, M6x16-8.8 HEX HEAD FULL THREAD ZINC	F81001-15	2	
26	DECAL, PRESSURE VALUES	510643	1	
27	BOLT, M8x70-8.8 HEX HEAD ZINC	F81002-71	4	

SECTION 4 SAW HEAD

4.1 Middle Throat Screw

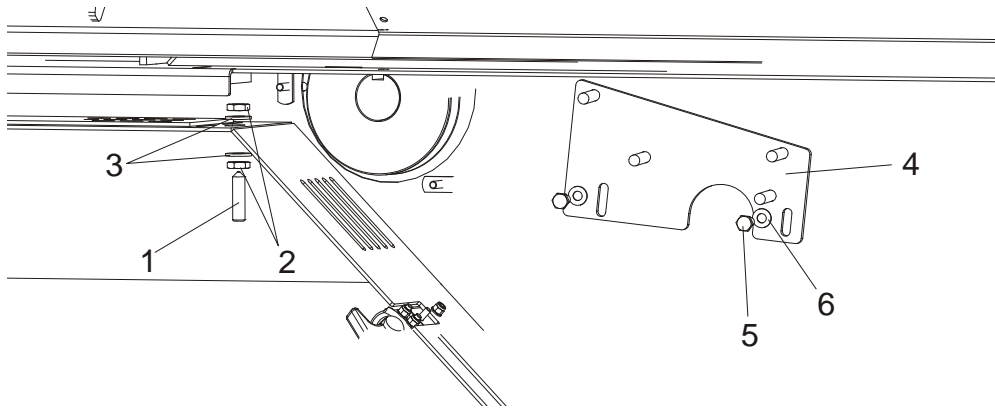

REF.	DESCRIPTION (◆ Indicates Parts Available In Assemblies Only)	PART #	QTY.
1	SCREW, M10 X 40-45H HEX SOCKET SET CONE POINT ZINC	F81003-61	1
2	NUT, M10-8-B ZINC HEX	F81033-6	2
3	WASHER, 10.5 ZINC FLAT	F81055-1	2
4	BRACKET, DRIVE BELT SUPPORT, UPPER	092668-1	1
5	BOLT, M8X20-5.8 HEX HEAD FULL THREAD ZINC	F81002-1	2
6	WASHER, 8.4 ZINC FLAT	F81054-1	2

4.2 Drive Belt Tensioner, DC Sawmills

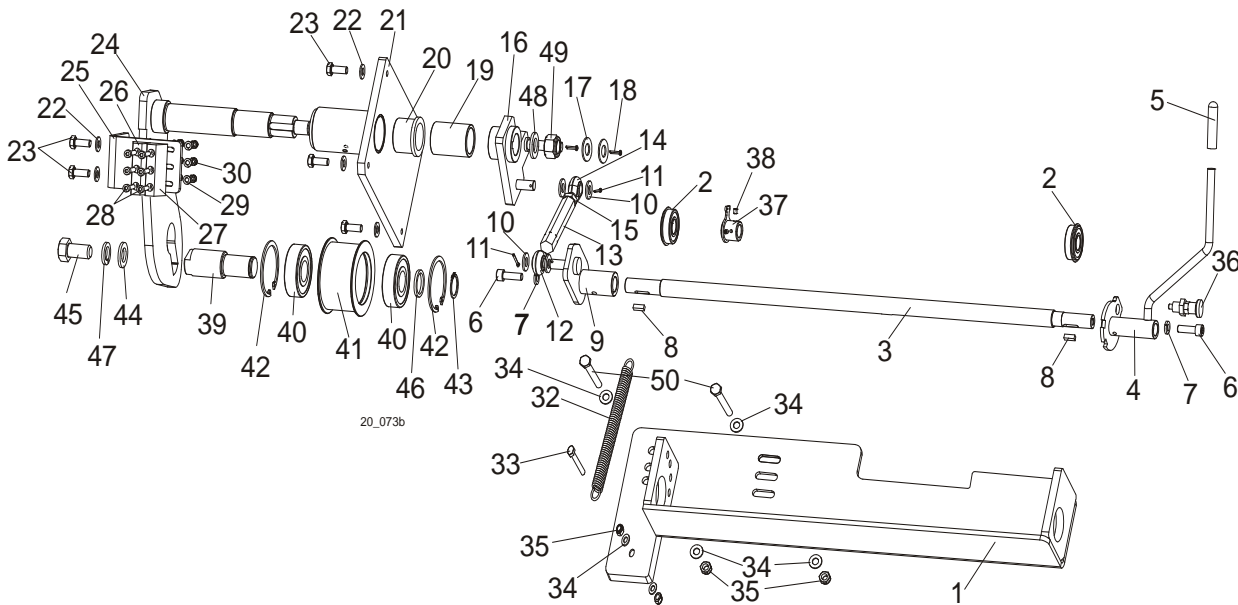

REF.	DESCRIPTION (◆ Indicates Parts Available In Assemblies Only)	PART #	QTY.
	BELT TENSIONER, LT20 COMPLETE, D22	098456	1
	BELT TENSIONER, LT20 COMPLETE, G25	097842	1
1	Mount Weldment, Belt Tensioner Ptd	091169-1	1
2	Bearing, 6203-2RS NR NSK w/Ring	086395	2
3	Rod, LT20 Belt Tensioner Ptd	091176-1	1
4	Handle Weldment, Accelerate/Brake, Ptd	097837-1	1

5	Grip, Handle 1/2" ID x 3" Long	014835	1	
6	Screw, M8x25 -8.8 Hex Socket Head Cap Zinc	F81002-21	2	
7	Washer, 8.2 Split Lock Zinc	F81054-4	2	
8	Key, B 5x5.1x14 Parallel	087365	2	
9	Bracket, Belt Tensioner Pivot	091245-1	1	
10	Washer, 10.5 Zinc Flat	F81055-1	4	
11	Pin, 2.5x20 Zinc Cotter	F81043-1	2	
12	Rod End, 7/16-20 Right-Hand Male	P11579	1	
13	Turnbuckle, Clutch/Brake	S11577	1	
14	Rod End, 7/16-20 Left-Hand Male	P11578	1	
15	Nut, 7/16-20 Zinc	F05010-38	1	
16	Arm Weldment, Belt Tensioner Ptd	091172-1	1	
17	Washer, 17 Zinc Flat	F81058-1	2	
18	Pin, 2.5x20 Zinc Cotter	F81043-1	2	
19	Bushing, Spacer Ptd	091351-1	1	
20	Bushing, MFM-3240-30 (IGUS)	088461	2	
21	Mount Weldment, Tensioner Shaft Ptd	091112-1	1	
22	Washer, 8.4 Zinc Flat	F81054-1	6	
23	Bolt, M8x20-5.8 Hex Head Full Thread Zinc	F81002-1	6	
24	Shaft Weldment, Belt Tensioner Ptd	097828-1	1	
25	Bracket, Brake Block Mount Ptd	091248-1	1	
26	Block, F9150 123 Belt Tensioner Brake	087648	1	
27	Block, F9150 123 Belt Tensioner Brake	087648	1	
28	Screw, M5x25-8.8 Hex Socket Head Cap Zinc	F81000-7	6	
29	Washer, 5.3 Zinc Flat	F81052-1	6	
30	Nut, M5-8 Zinc DIN 985	F81030-2	6	
31	Screw, M8x25-8.8 Hex Socket Head Cap Zinc	F81002-21	1	
32	Spring, Hydraulic Log Turner	P09136	1	
33	Bolt, M8x45-8.8 Hex Head Zinc	F81002-17	1	
34	Washer, 8.4 Zinc Flat	F81054-1	6	
35	Nut, M8-8-B Hex Nylon Zinc Lock	F81032-2	3	
36	Pin, Detent	089939	1	
37	Tension Member, (G25 Engine Only) Ptd	092535-1	1	
38	Set Screw M6x8	F81013-1	2	
	Roller, Tension Complete	509902	1	
39	Axle, Belt Tension Wheel Zinc	509901-1	1	
40	Bearing Wheel, Idle Side 6305 2RS NSK.	P08066	2	
41	Wheel, LT15 Belt Tension Zinc	087671-1	1	
42	Ring, 62W Inside Spring Retaining	F81090-1	2	
43	Ring, 25Z Outside Retaining	F81090-22	1	
44	Washer, 17 Flat Zinc	F81058-1	1	
45	Bolt, M16x30-8.8 Hex Head Full Thread Zinc	F81006-36	1	
46	WASHER, DRIVE ASSY, ZINC	500863-1	1	
47	WASHER,16.3 SPLIT LOCK ZINC	F81058-2	1	
48	Washer, 17 Flat Zinc	F81058-1	1	
49	Nut, M16-8 Hex Nylon Zinc Lock	F81036-2	1	
50	Bolt, M8 X 75 8.8 Hex Head Zinc	F81002-91	2	

4.3 Water Lube Assembly

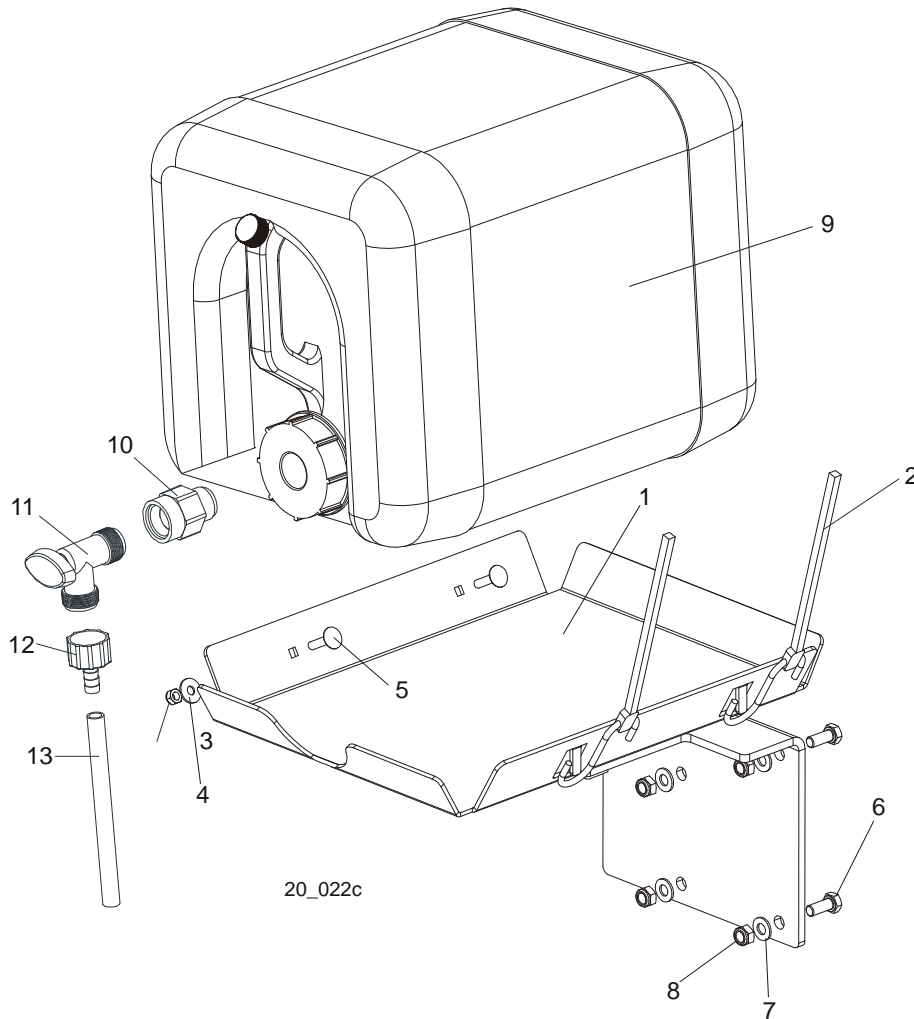

REF.	DESCRIPTION (◆ Indicates Parts Available In Assemblies Only)	PART #	QTY.
	BOTTLE KIT, LT20 WATER LUBE	091036	1
1	Tray Weldment, LT20 Water Lube	091033-1	1
2	Strap, 20" Rubber	P11668	2
3	Nut, M6-8-B Hex Nylon Zinc Lock	F81031-2	2
4	Washer, 6.5 Zinc Flat	F81053-11	2
5	Bolt, M6x25-8.8 Carriage Head Zinc	F81001-20	2
6	Bolt, M8x20-8.8 Hex Head Full Thread Zinc	F81002-1	2
7	Washer, 8.4 Zinc Flat	F81054-1	2
8	Nut, M8-8-B Hex Nylon Zinc Lock	F81032-2	2
9	Bottle, 5-gallon Water	014637	1
10	Fitting, 3/4FPT x 3/4MPT	014636	1
11	Fitting, Water Lube Shutoff Valve	014100	1
12	Fitting, 5/8" NPT to 3/8" Hose Barb	014113	1
13	Tubing, Water Lube	R01885	2.1 m

4.4 Blade Lube System

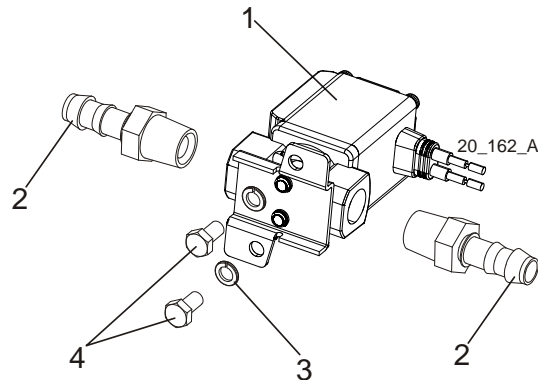

REF.	DESCRIPTION (◆ Indicates Parts Available In Assemblies Only)	PART #	QTY.
	KIT, LT20AC BLADE LUBE SYSTEM	503517	1
1	SOLENOID, WATER LUBE	509113	1
2	FITTING, 3/8 BARB 1/4NPT MALE NYLON	P04682	2
3	WASHER, 5.1 SPLIT LOCK ZINC	F81052-2	2
4	SCREW, 10-32X1/2 HH MACHINE	F05004-60	2
	CONNECTOR, 16-14GA FI BUTT	F04875-1	2
	CONDUIT, 1/2IN EXPANDABLE BLACK	R02374	1m
	KIT, LT20DC BLADE LUBE SYSTEM	503518	1
1	SOLENOID, WATER LUBE	509113	1
2	FITTING, 3/8 BARB 1/4NPT MALE NYLON	P04682	2
	CONDUIT, 1/2IN EXPANDABLE BLACK	R02374	1m

4.5 LT20AC Saw Head Decals

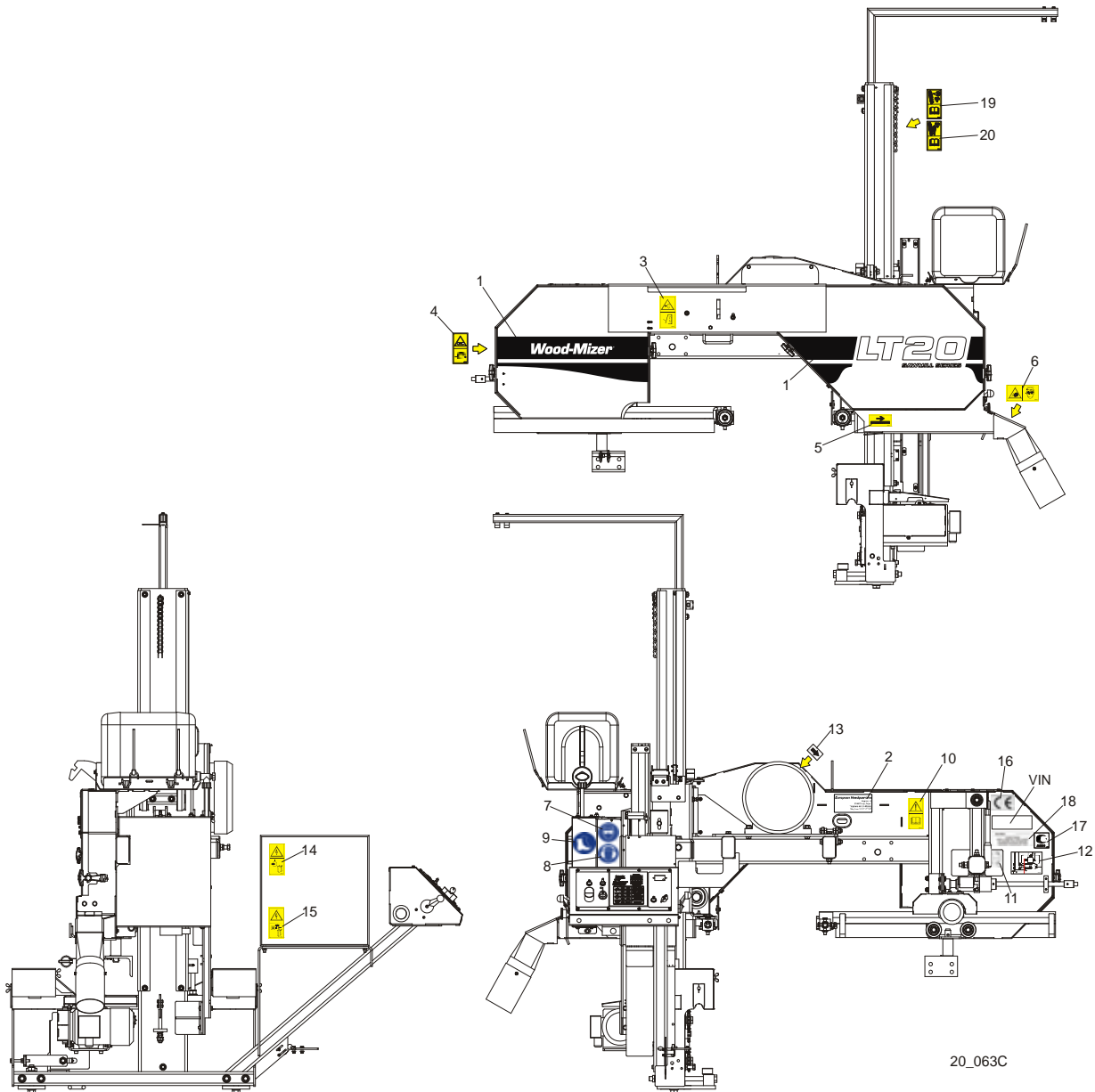

20_063C

REF.	DESCRIPTION (◆ Indicates Parts Available In Assemblies Only)	PART #	QTY.
1	DECAL, LT20 SERIES SAWMILL	092762	1
	PICTOGRAPHIC DECAL KIT, LT20AC	099509	1
2	DECAL, EUROPEAN HEADQUARTERS ADDRESS	015841	1
3	DECAL, SAWMILL COVERS CAUTION	099220	1
4	DECAL, BLADE TENSION (PICTOGRAM)	099219	1
5	DECAL, BLADE MOVEMENT DIRECTION (PICTOGRAM)	096321	1
6	DECAL, SAWDUST CHUTE WARNING (PICTOGRAM)	099222	1
7	DECAL, EYE PROTECTION WARNING (PICTOGRAM)	S12004G	1
8	DECAL, EAR PROTECTION WARNING (PICTOGRAM)	S12005G	1
9	DECAL, USE SAFETY BOOTS (PICTOGRAM)	501465	1
10	DECAL, READ OPERATOR'S MANUAL (PICTOGRAM)	096317	1

4

Saw Head*LT20AC Saw Head Decals*

11	DECAL, BLADE ALIGNMENT	P11789	1	
12	DECAL, BLADE TENSION INDICATOR ADJUSTMENT	092597	1	
13	DECAL, MOTOR ROTATION DIRECTION	S20097	1	
14	DECAL, HIGH VOLTAGE INSIDE THE ELECTRIC BOX (PICTOGRAM)	096316	2	
15	DECAL, REMOVE THE PLUG BEFORE OPENING THE BOX (PICTOGRAM)	096319	2	
16	DECAL, CE CERTIFIED SAWMILL	P85070	2	
17	DECAL, RUSSIAN SAFETY CERTIFICATION	099401	1	
18	DECAL, INTERNATIONAL SAWMILL NAME	501466	1	
	DECAL, BLADE SETTING	P85066	1	
	DECAL, KEEP AWAY DANGER, PICTOGRAM	099221	1	
	DECAL, MAX. OIL PRESSURE, PICTOGRAM	099524	1	
19	DECAL, LUBRICATE THE CHAIN	512158	1	
20	DECAL, CLEAN THE CHAIN	512240	1	

4.6 LT20DC Saw Head Decals

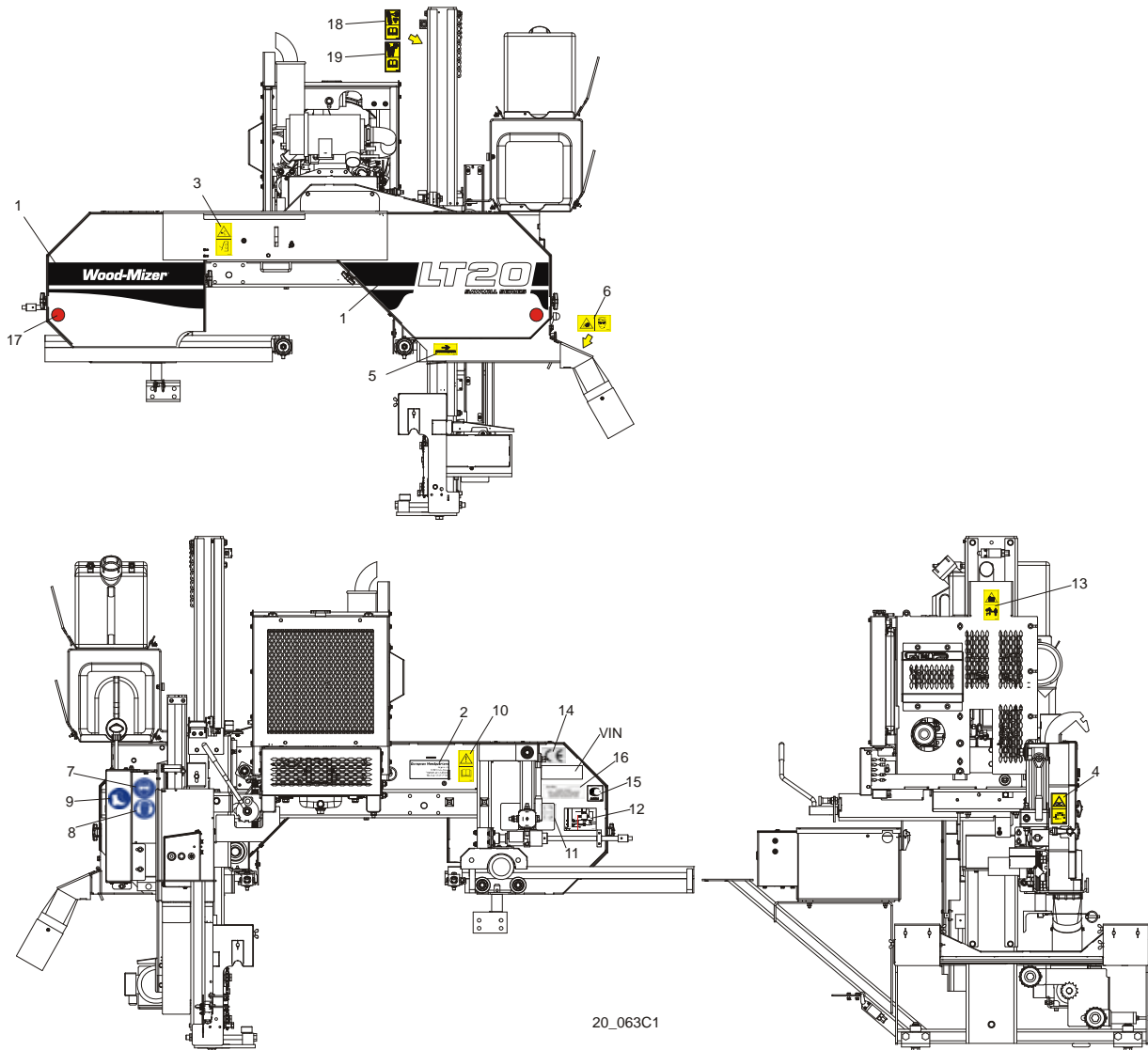

REF.	DESCRIPTION (◆ Indicates Parts Available In Assemblies Only)	PART #	QTY.
	DECAL, LT20 SERIES SAWMILL	092762	1
1	PICTOGRAPHIC DECAL KIT, LT20DC	099510	1
2	DECAL, EUROPEAN HEADQUARTERS ADDRESS	015841	1
3	DECAL, SAWMILL COVERS CAUTION	099220	1
4	DECAL, BLADE TENSION (PICTOGRAM)	099219	1
5	DECAL, BLADE MOVEMENT DIRECTION (PICTOGRAM)	096321	1
6	DECAL, SAWDUST CHUTE WARNING (PICTOGRAM)	099222	1
7	DECAL, EYE PROTECTION WARNING (PICTOGRAM)	S12004G	1
8	DECAL, EAR PROTECTION WARNING (PICTOGRAM)	S12005G	1
9	DECAL, USE SAFETY BOOTS (PICTOGRAM)	501465	1
10	DECAL, READ OPERATOR'S MANUAL (PICTOGRAM)	096317	1
11	DECAL, BLADE ALIGNMENT	P11789	1
12	DECAL, BLADE TENSION INDICATOR ADJUSTMENT	092597	1

4**Saw Head***LT20DC Saw Head Decals*

13	DECAL, KEEP AWAY - HOT PARTS (PICTOGRAM)	086099	1	
14	DECAL, CE CERTIFIED SAWMILL	P85070	1	
15	DECAL, RUSSIAN SAFETY CERTIFICATION	099401	1	
16	DECAL, INTERNATIONAL SAWMILL NAME	501466	1	
17	REFLECTOR, 2 DIA RED (MOBILE SAWMILLS ONLY)	P07452	1	
18	DECAL, LUBRICATE THE CHAIN	512158	1	
19	DECAL, CLEAN THE CHAIN	512240	1	

4.7 Blade Housing Cover

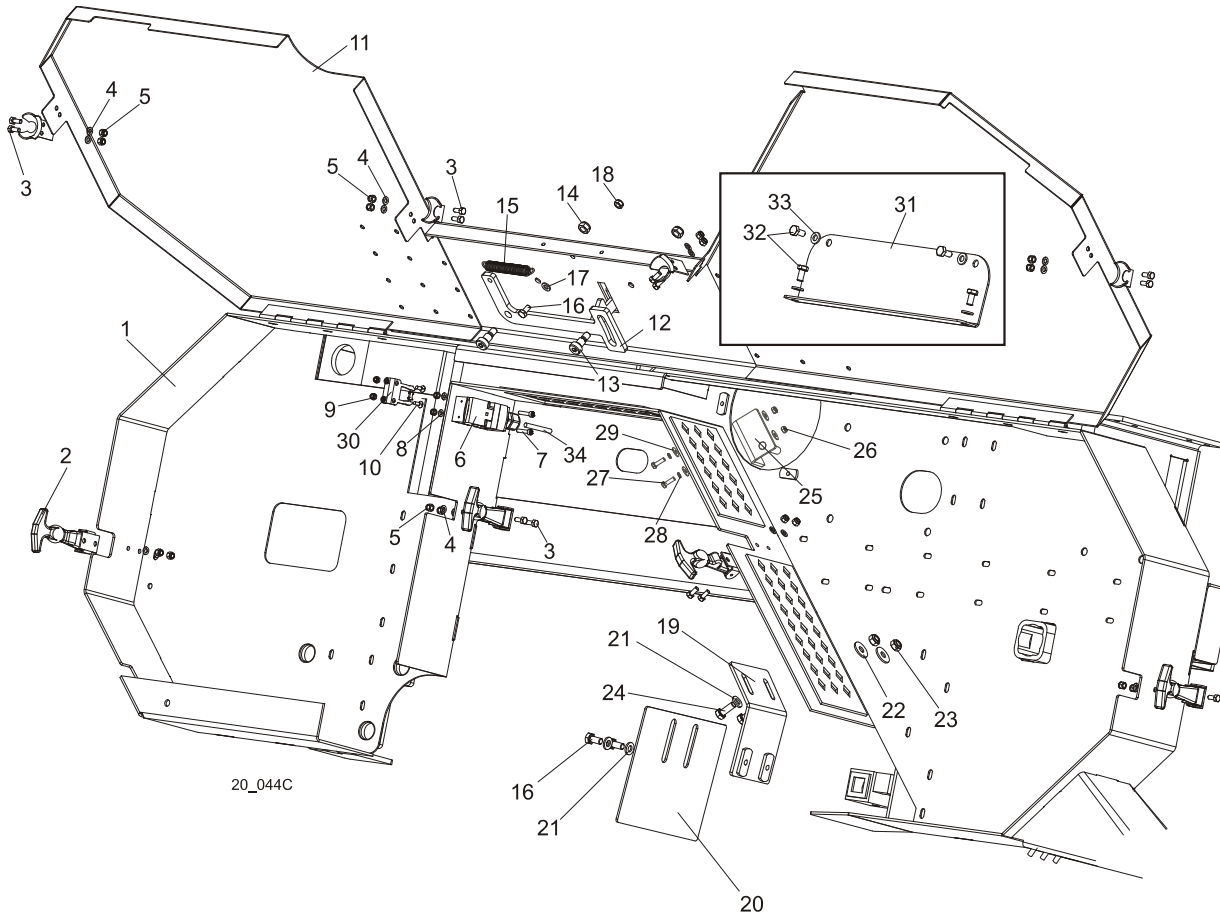

REF.	DESCRIPTION (◆ Indicates Parts Available In Assemblies Only)	PART #	QTY.
1	SAW HEAD WELDMENT, LT20	090567	1
2	LATCH, FLEXIBLE DRAW	014829	4
3	BOLT, M5 X 12-5.8 HEX HEAD FULL THREAD ZINC	F81000-5	16
4	WASHER, 5.3 ZINC FLAT	F81052-1	16
5	NUT, M5-8 HEX NYLON ZINC LOCK	F81030-2	16
6	SWITCH, AZ17-11ZRK SAFETY KEY	094232	1
7	SCREW, M4 X 35 8.8 HEX SOCKET HEAD CAP ZINC	F81011-34	2
8	WASHER, 4.3 ZINC FLAT	F81051-2	4
9	NUT, M4-B HEX NYLON ZINC LOCK	F81029-1	4
10	SCREW, M4 X 12 5.8-B SLOTTED COUNTERSUNK HEAD ZINC	F81011-43	2
11	COVER WELDMENT, LT20 BLADE HOUSING PTD	096776-1	1
12	PAWL, LOCKING PTD	090643-1	1
13	SCREW, 10/M8 X 12-12.9 ISO-7379 SOCKET HEAD SHOULDER	F81003-62	2
14	NUT, M8-8-B HEX NYLON ZINC LOCK	F81032-2	2
15	SPRING, 1,6x12x38 EXTENSION	092208	1
16	BOLT, M6 X 12-8.8 HEX HEAD FULL THREAD ZINC	F81001-7	3
17	WASHER, 6.4 ZINC FLAT	F81053-1	1

4

Saw Head*Blade Housing Cover*

18	NUT, M6-8-B HEX NYLON ZINC LOCK	F81031-2	1	
19	BRACKET, BLADE GUIDE ROLLER GUARD PAINTED	092378-1	1	
20	GUARD, BLADE GUIDE ROLLER PAINTED	092379-1	1	
21	WASHER, 6.4 ZINC FLAT	F81053-1	4	
22	WASHER, 6.5 ZINC FLAT	F81053-11	2	
23	NUT, M6-8-B HEX NYLON ZINC LOCK	F81031-2	2	
24	BOLT, M6X16 8.8 HEX HEAD FULL THREAD ZINC	F81001-15	2	
25	BRACKET WLDMT, PTD DRIVE BELT SUPPORT	092636-1	1	
26	NUT, M6-8-B HEX NYLON ZINC LOCK	F81031-2	2	
27	BOLT, M6 X 20-8.8 HEX HEAD FULL THREAD ZINC	F81001-2	2	
28	WASHER 6,1 FE/ZN9 PN/M-82008	F81053-3	2	
29	WASHER, 6.5 ZINC FLAT	F81053-11	4	
30	KEY, AZ17/170-B5 SAFETY SWITCH	094422	1	
31	COVER, SAW HEAD MOUNT	096788-1	1	
32	BOLT, M6X12MM HEX HEAD ZINC	F81001-7	4	
33	WASHER, M6 FLAT ZINC	F81053-1	4	
34	CABLE, OLFLEX 400P 2X1	R80583-5	3m (DC) 5m (AC)	

4.8 Control Box (AC Sawmills)

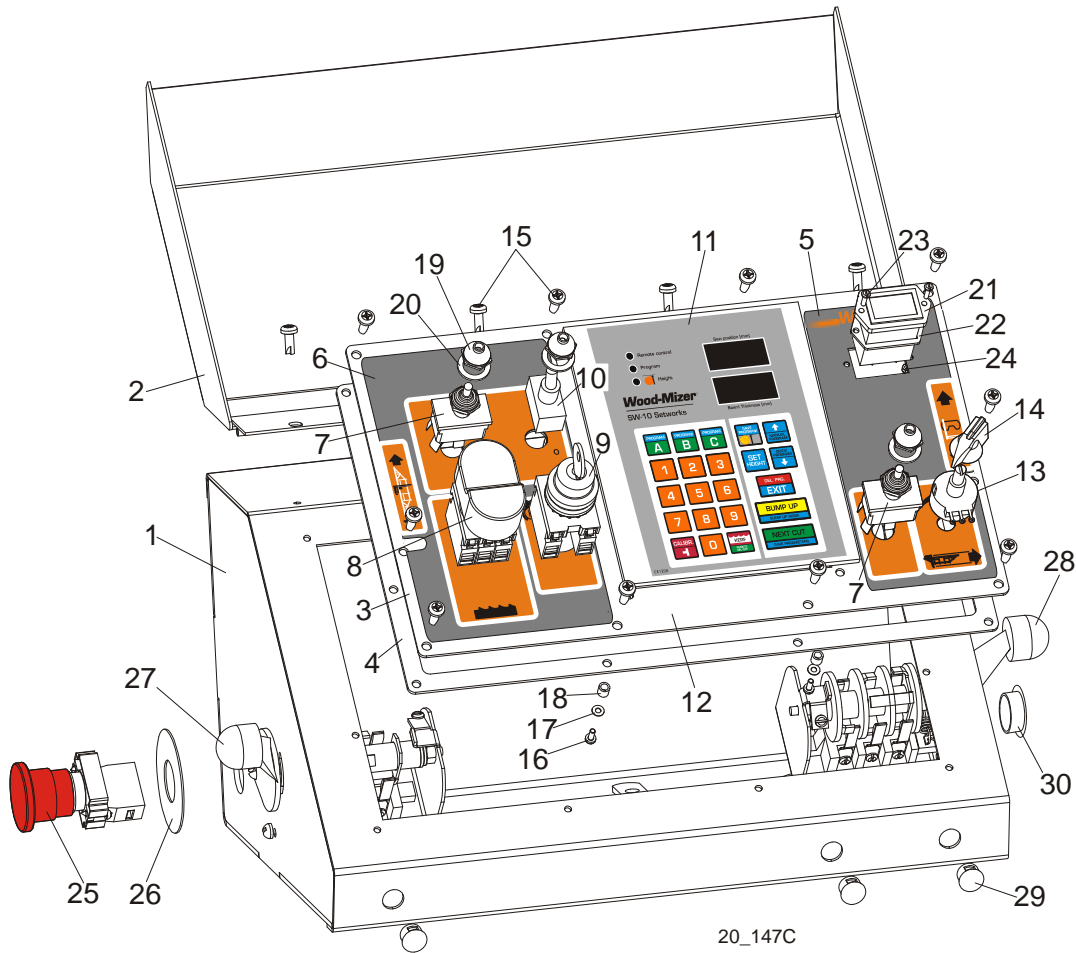

REF.	DESCRIPTION (◆ Indicates Parts Available In Assemblies Only)	PART #	QTY.
	CONTROL BOX ASSEMBLY, LT20 AC COMPLETE	097136	1
1	Box Weldment, LT20 AC Control	097134-1	1
2	Cover Control Box, LT20	097135-1	1
3	Panel, LT20AC Front Control Complete	097131	1
4	Gasket, LT20 Control Box	097132	1
5	Decal, LT20AC/DC Control Box Right	099593	1
6	Decal, LT20AC Control Box Left	099594	1
7	Switch, DPDT Toggle 21A Rev Mom Spade	024200	2
8	Button, 24V Start/Stop	090452	1
	Membrane, M22-T-DD	090462	1
9	Switch, M22 3-position Key	091361	1
	Contact, M22 - K10	091362	2
10	Switch, SPST ON/OFF 15A .25 Tabs Toggle	P03027	1
11	Controller, SW-10 Setworks	500628	1
12	Panel, LT20/40AC Front Control	100572-1	1
13	Potentiometer, 1K Feed Rate	E20519	1
14	Knob, Speed Control	P06257	1
15	Bolt, #10-24x1/2 Ph Pan Hd, Type 23	F05015-17	14

4

Saw Head*Control Box (AC Sawmills)*

16	Screw, M3x8 -4.8- Fe/Zn5 PN-M/82202	F81000-83	6	
17	Washer, 3.2 Flat Zinc	F81050-2	6	
18	Tube, 6mm 4.2 long	R80671-4	6	
19	Boot, Toggle Switch	P02575	3	
20	Washer, 1/2x3/4x1/16 Nylon	P05251-1	3	
21	Meter, Hour	093166	1	
22	Gasket, Hour Meter	093346	1	
23	Bolt, M3x12-8.8 Zinc	F81000-12	2	
24	Nut, M3-6 Hex Nylon Zinc Lock	F81028-2	2	
25	Button, XB4 BS542 Emergency Stop	086556	1	
26	Washer, Emergency Stop Switch	086561	1	
27	Switch, 1992GS Pwr/Feed (Service Package)	E20438	1	
28	Switch, 1992 Up/Down (Service Package)	E20440	1	
29	Cap, DP 812 Heyman 12.7 Dia. Hole	086773	3	
30	Cap, SR1086 22.2 Dia. Hole	093544	1	

4.9 Control Box (DC Sawmills)

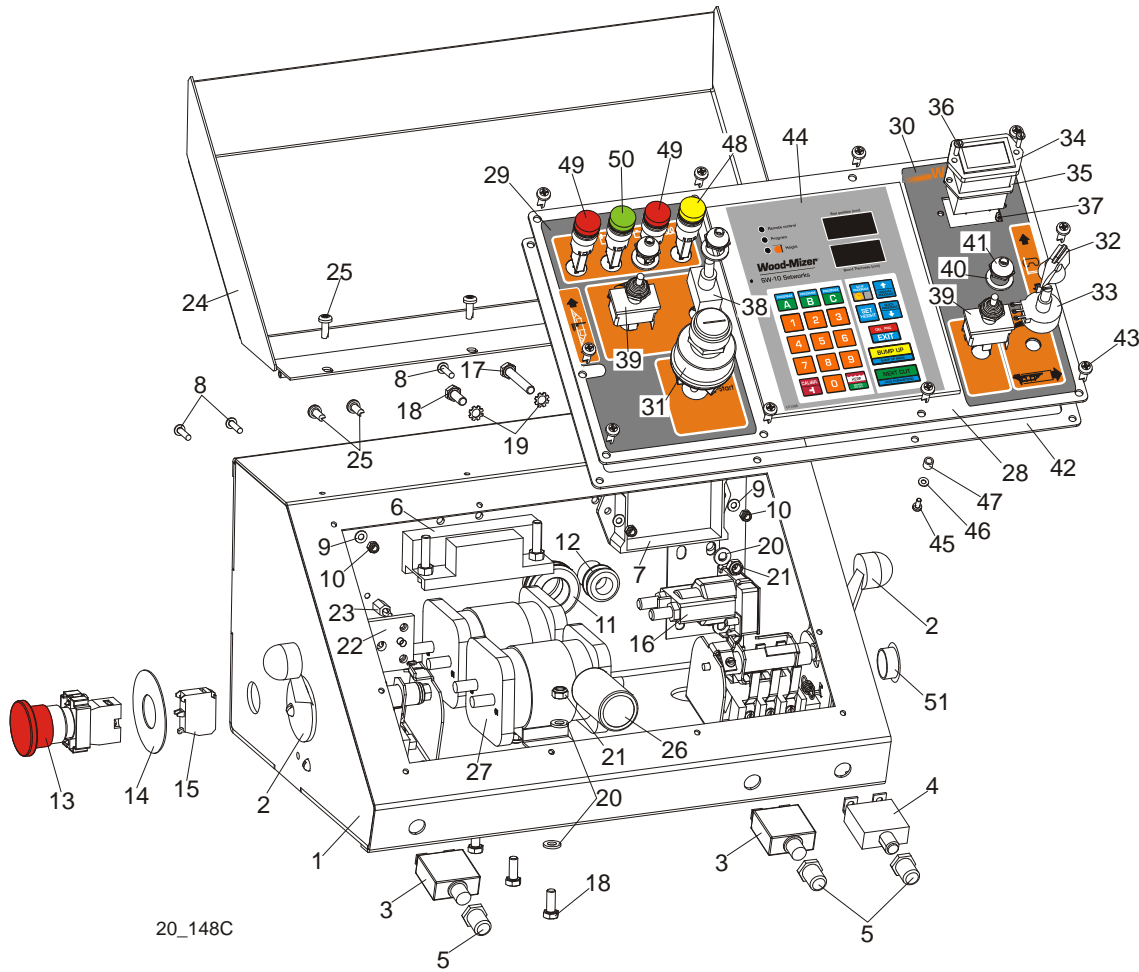

REF.	DESCRIPTION (◆ Indicates Parts Available In Assemblies Only)	PART #	QTY.
	CONTROL BOX ASSEMBLY, LES DC COMPLETE	500656	1
1	Box Weldment, LT20 DC	097165-1	1
2	Switch, 1992GS Pwr/Feed (Service Package)	E20438	2
3	Breaker, 50A Manual Reset Panel Mount	021256	2
4	Breaker, 30A Manual Reset Panel Mount	024246	1
5	Boot, Circuit Breaker	021253	3
6	Module Assy, Mosfet 4x 92-96 P/F	024540	1
7	Control Module Assy, P/F SMT Service '97	024396	1
8	Screw, M4x16 5.8-B Cross Recessed Pan Head	F81011-42	4
9	Washer, 4.3 Flat Zinc	F81051-2	4
10	Nut, M4-B Hex Nylon Zinc Lock	F81029-1	4
11	Grommet, 22mm Rubber	087400	1
12	Grommet, 20/13 Rubber	086188	1
13	Button, XB4 BS542 Emergency Stop	086556	1
14	Washer, ZBY9330 Emergency Stop Button	086561	1
15	Contact, ZBE102	086810	1
16	Solenoid, 120-943 Hyd Shut-Off	P10449	1
17	Bolt, M6x40-8.8Hex Head Full Thread Zinc	F81001-5	1

4

Saw Head**Control Box (DC Sawmills)**

18	Bolt, M6x16 8.8 Hex Head Full Thread Zinc	F81001-15	6	
19	Washer, 6.4 Star Lock Zinc	F81053-2	2	
20	Washer, 6.4 Flat Zinc	F81053-1	8	
21	Nut, M6-8-B Hex Nylon Lock Zinc	F81031-2	5	
22	Radiator, Diode	091867	1	
23	Spacer, P3/12	R80671-2	4	
24	Cover Weldment, LT20 Complete	097135-1	1	
25	Bolt, #10-24x1/2 Ph Pan Hd, Type 23	F05015-17	6	
26	Capacitor, 10000/63V Elektrolytic	091166	1	
27	Solenoid, 200A 12V DPST	015417	2	
	Panel, LT20DC Front Complete	097163	1	
28	Panel, LT20/40DC Front	100573-1	1	
29	Decal, LT20DC Control Box Left	099592	1	
30	Decal, LT20AC/DC Control Box Right	099593	1	
31	Switch, Key	P04350	1	
32	Knob, Speed Control	P06257	1	
33	Potentiometer, 1k	E20519	1	
34	Meter, Hour	093166	1	
35	Gasket, Hour Meter	093346	1	
36	Bolt, M3x12-8.8 Zinc	F81000-12	2	
37	Nut, M3-6 Hex Nylon Zinc Lock	F81028-2	2	
38	Switch, SPST On/Off 15A.25 Tabs Toggle	P03027	1	
39	Switch, DPDT Toggle 21A Rev Mom Spade	024200	2	
40	Washer, 1/2x3/4x1/16 Nylon	P05251-1	3	
41	Boot, Toggle Switch	P02575	3	
42	Gasket, LT20 Control Box	097132	1	
43	Bolt, #10-24x1/2 Ph Pan Hd, Type 23	F05015-17	10	
44	Controller, SW-10 Setworks	500628	1	
45	Screw, FH ST 3,5x6,5 A4	F81000-82	6	
46	Washer, 3.2 Flat Zinc	F81050-2	6	
47	Spacer, 4.2x6mm Idler	R80671-4	6	
48	Light, XB6AV5BB Yellow	089812	1	
49	Light, XB6AV4BB Red	091099	2	
50	Light, XB6AV3BB Green	087348	1	
51	Cap, SR1086 22.2 Dia. Hole	093544	1	

4.10 Drum Switches

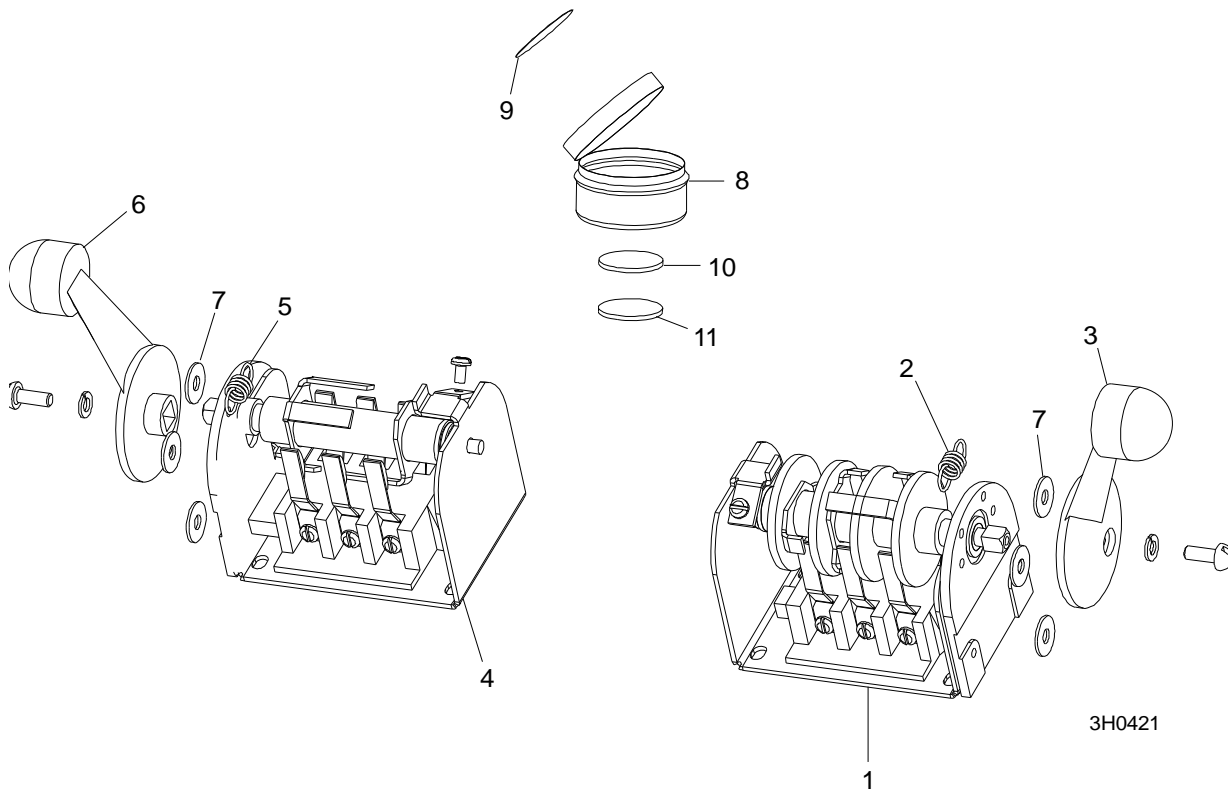

REF.	DESCRIPTION (◆ Indicates Parts Available In Assemblies Only)	PART #	QTY.	
	SWITCH ASSEMBLY, UP/DOWN DRUM	E20440	1	
1	Switch, Drum	E20440-B	1	◆
2	Spring, Drum Switch	P12570	1	
3	Handle, Drum Switch w/Screws	P12500	1	
	SWITCH ASSEMBLY, POWER FEED DRUM	E20438	1	
4	Switch, Drum	E20438-B	1	◆
5	Spring, Drum Switch	P12570	1	
6	Handle, Drum Switch w/Screws	P12500	1	
7	WASHER, #8 SAE FLAT	F05011-41	6	
	CUP ASSEMBLY, DRUM SWITCH GREASE	A20463	1	
8	Cup, Plastic Container	P20464	1	◆
9	Label, Grease Cup	P20467	1	
10	Pad, Velcro Loop	P20466	1	◆
11	Pad, Velcro Hook	P20465	1	◆
	Grease, Drum Switch	P20468	.011ml	◆

4.11 Sawdust Chute

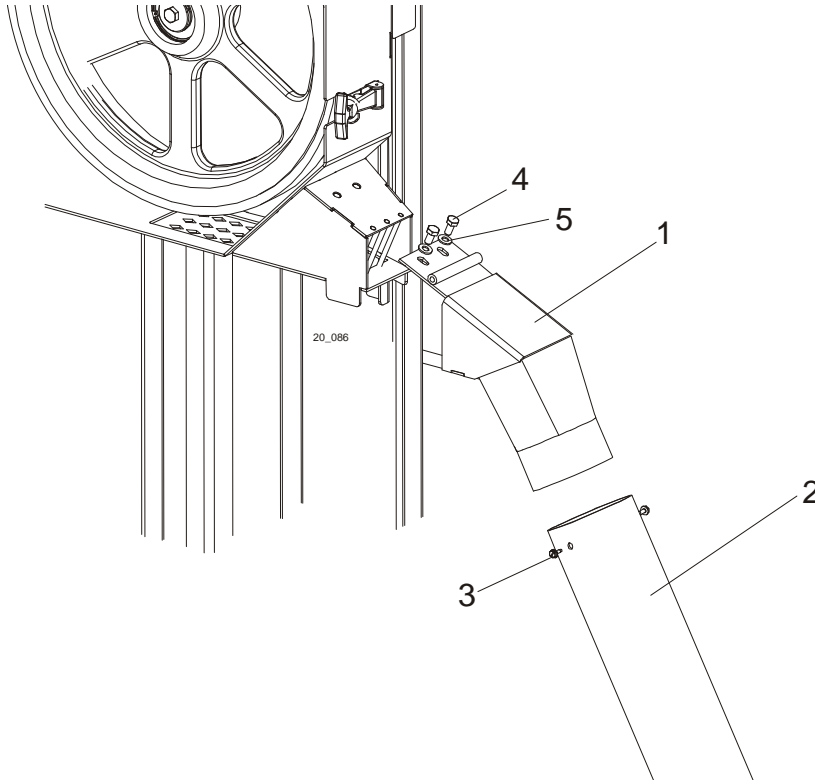

REF.	DESCRIPTION (◆ Indicates Parts Available In Assemblies Only)	PART #	QTY.	
1	CHUTE WELDMENT, SAWDUST	100903-1	1	
2	TUBE, SAWDUST CHUTE RUBBER	R02336	1	
3	SCREW, #10-24 X 1/2 SELF-TAPPING	F05015-7	2	
4	BOLT, M8x16-8.8-B HEX HEAD FULL THREAD ZINC	F81002-20	2	
5	WASHER, 8.4 ZINC FLAT	F81054-1	2	

4.12 Up/Down Cable Chain Assembly

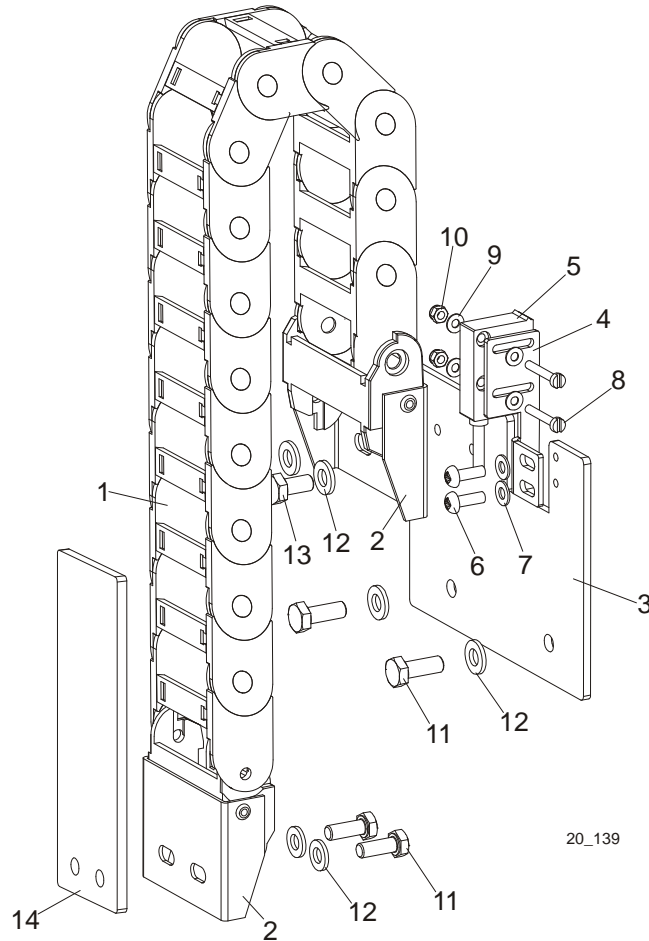

REF.	DESCRIPTION (◆ Indicates Parts Available In Assemblies Only)	PART #	QTY.
	HARNESS GUIDE AND SENSOR ASSEMBLY	098052	1
1	Harness Guide, SR300A 050 080	097924	1
2	Bracket, AN300A 050K Mount	097925	1
3	Mounting Plate, Harness and Sensor Assy.	096067-1	1
4	Bracket, Sensor Mount	096068-1	1
5	Sensor, MSK-320	096014	1
6	Screw, M4x12-5,8-B Zinc	F81011-43	2
7	Washer, 4.3 Flat Zinc	F81051-2	2
8	Screw, M3x20-5.8-A Zinc	F81000-8	2
9	Washer, 3.2 Flat Zinc	F81050-2	4
10	Nut, M3-6 Hex Nylon Zinc Lock	F81028-2	2
11	Bolt, M6x20-8.8 Hex Head Zinc	F81001-2	4
12	Washer, 6.4 Flat Zinc	F81053-1	6
13	Bolt, M6x12-8.8 Hex Head Zinc	F81001-7	2
14	Plate, Guide Mount	098662-1	1

4.13 LES Control Box Bracket

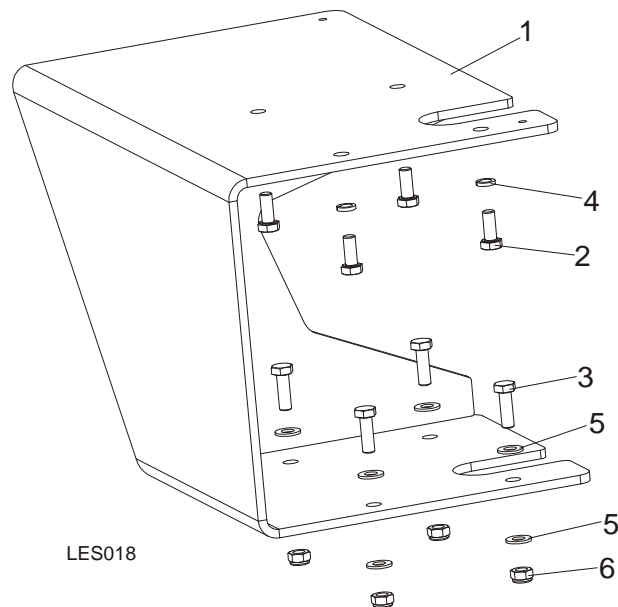

REF.	DESCRIPTION (◆ Indicates Parts Available In Assemblies Only)	PART #	QTY.
	BRACKET, LES CONTROL BOX	101178	1
1	BRACKET, LES CONTROL BOX	100542-1	1
2	BOLT, M8X20-5.8 HEX HEAD FULL THREAD ZINC	F81002-1	4
3	BOLT, M8X25-8.8-B HEX HEAD FULL THREAD ZINC	F81002-5	4
4	WASHER, 8.2 SPLIT LOCK ZINC	F81054-4	4
5	WASHER, 8.4 FLAT ZINC	F81054-1	8
6	NUT, M8-8-B HEX NYLON ZINC LOCK	F81032-2	4

4.14 Saw Head Safety Device For LT20B Sawmills

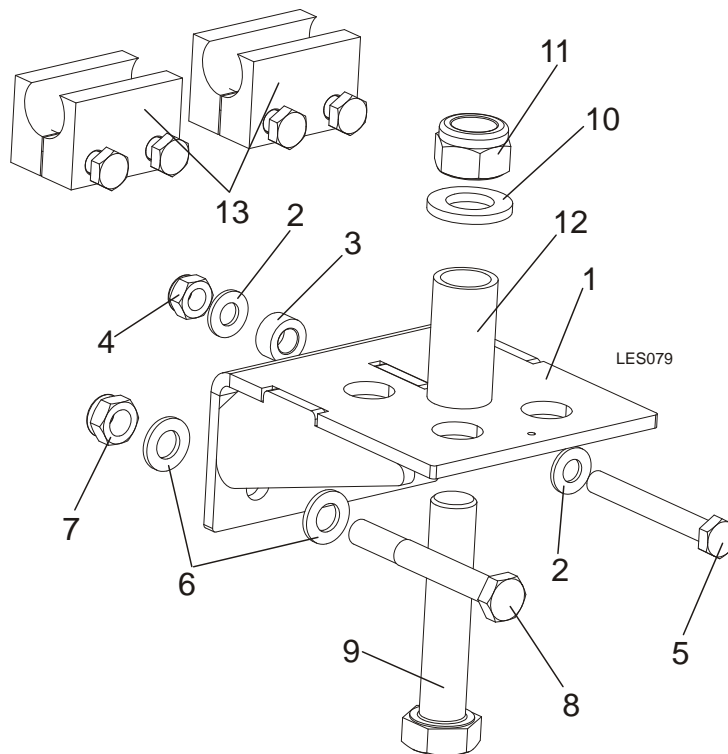

REF.	DESCRIPTION (◆ Indicates Parts Available In Assemblies Only)	PART #	QTY.
	SAW HEAD SAFETY DEVICE, LT20B	504326	1
	SAW HEAD SAFETY DEVICE, LT20B	504328	1
1	BRACKET WDMT, SAW HEAD SAFETY PIN PTD	092699-1	1
2	WASHER, 10.5 FLAT ZINC	F81055-1	2
3	BUSHING, ZINC-PLATED SPACER	090936-1	1
4	NUT, M10-8-B HEX NYLON ZINC LOCK	F81033-1	1
5	BOLT, M10 X 80 -8.8 HEX HEAD ZINC	F81003-50	1
6	WASHER, 13 FLAT ZINC	F81056-1	2
7	NUT, M12-8 HEX NYLON ZINC LOCK	F81034-2	1
8	BOLT, M12x95 -8.8- HEX HEAD ZINC-PLATED	F81004-29	1
9	BOLT, M20X100-8.8 HEX HEAD ZINC	F81007-6	1
10	WASHER, 21 FLAT ZINC	F81059-2	1
11	NUT, M20-8-A HEX NYLON ZINC LOCK	F81037-2	1
12	BUSHING, SPACER	504327-1	1
13	STOP, CARRIAGE SAFETY PAINTED (UKRAINE)	085973-1	2

SECTION 5 UP/DOWN ASSEMBLY

5.1 Up/Down Assembly, AC Mills

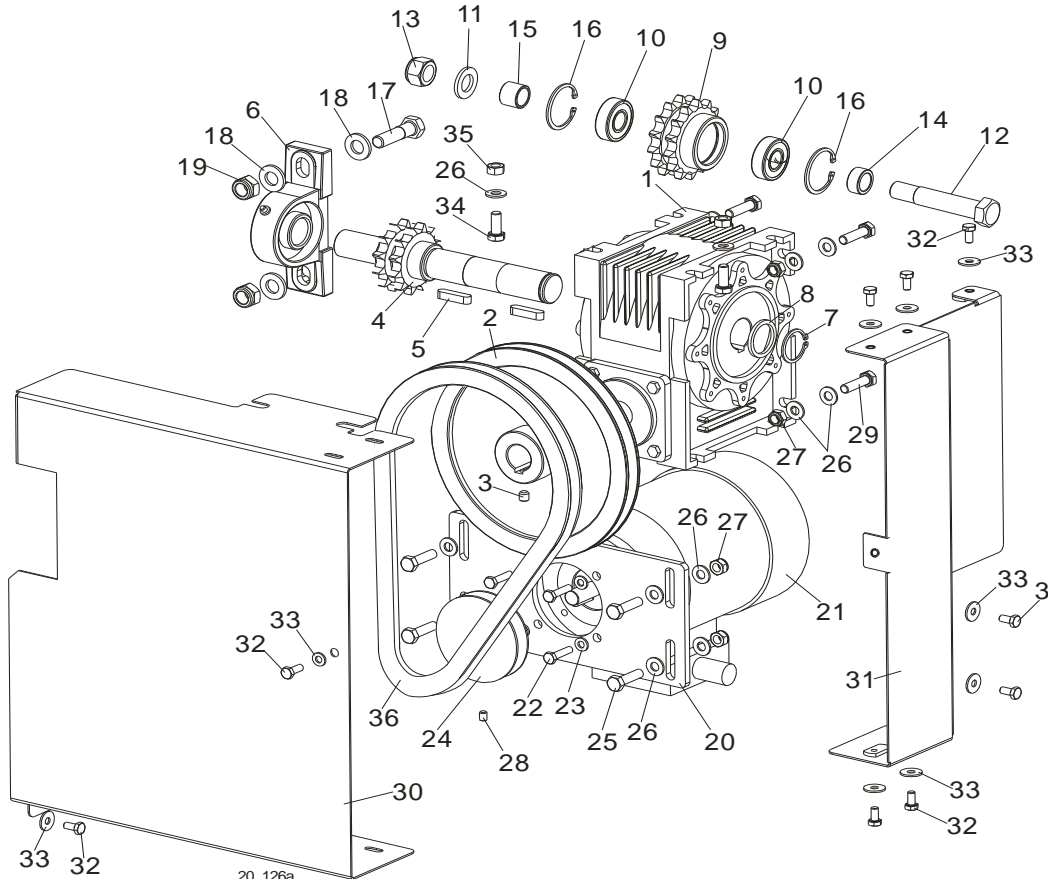

REF.	DESCRIPTION (◆ Indicates Parts Available In Assemblies Only)	PART #	QTY.	
	MOTOR ASSEMBLY, LT20 AC UP/DOWN	098300	1	◆
	Motor Assembly, LT20 Up/Down	098299	1	
1	Box, R-63/66/F1/B3 Gear	097786	1	
2	Pulley, LT20	091078-1	1	
3	Screw, M8x8-33H Hex Socket Set Flat Point	F81014-1	1	
4	Shaft, LT20 Up/Down w/Sprocket	512249-1	1	
5	Key, A8x7x32 Parallel	088564	2	
6	Bearing Assembly, UCP 205CX	088468	1	
7	Ring, Z28 Outside Retaining	F81090-12	1	
8	Washer	098351	1	
	Sprocket Assembly	512276	2	
9	Sprocket, ULMER T08260	512247-1	1	
10	Spacer, Drive Bearing	098166	2	
11	Washer, M16 Flat Zinc	F81058-1	2	
12	Pin, Up/Down Drive Shaft	098289-1	1	
13	Nut, M16-8 Hex Nylon Zinc Lock	F81036-2	1	

14	BUSHING, D42 BELT TENSIONER SPACER ZINC-PL.	087965-1	1	
15	BUSHING, UP/DOWN SPROCKET SPACER ZINC-PL.	088792-1	1	
16	RING, W40 INSIDE RETAINING	F81090-3	2	
17	Bolt, M12x45-8.8 Hex Head Zinc	F81004-32	2	
18	Washer, 13 Flat Zinc	F81056-1	4	
19	Nut, M12-8 Hex Nylon Zinc Lock	F81034-2	2	
	Motor Assembly, LT20 AC Up/Down	091302	1	
20	Plate, LT20AC Up/Down Motor Mount	098355-1	1	
21	Motor, SKh 71- 4B2 RAL 9005	091304	1	
22	Bolt, M6x25-5.8 Hex Head Full Thread Zinc	F81001-3	4	
23	Washer, 6.4 Flat Zinc	F81053-1	4	
24	Pulley, LT20 Power Feed Gear Box	090699-1	1	
25	Bolt, M8x30-5.8 Hex Head Full Thread Zinc	F81002-2	4	
26	Washer, 8.4 Flat Zinc	F81054-1	18	
27	Nut, M8-8-B Hex Nylon Zinc Lock	F81032-2	8	
28	Screw, M6x8 Hex Socket Set Flat Point Zinc	F81013-1	1	
29	Bolt, M8x30-8.8-B Hex Head Full Thread Zinc	F81002-7	4	
30	Guard, Up/Down Front	098393-1	1	
31	Guard, Side Complete	098395-1	1	
32	Bolt, M6x12-8.8 Hex Head Full Thread Zinc	F81001-7	9	
33	Washer, 6.5 Special Flat Zinc	F81053-11	9	
34	Bolt, M8x20-5.8 Hex Head Full Thread Zinc	F81002-1	2	
35	Nut, M8-8-B Hex Zinc	F81032-1	2	
36	V-Belt, HA-800 (Kleberg)	091086	1	

5.2 Up/Down Assembly, DC Mills

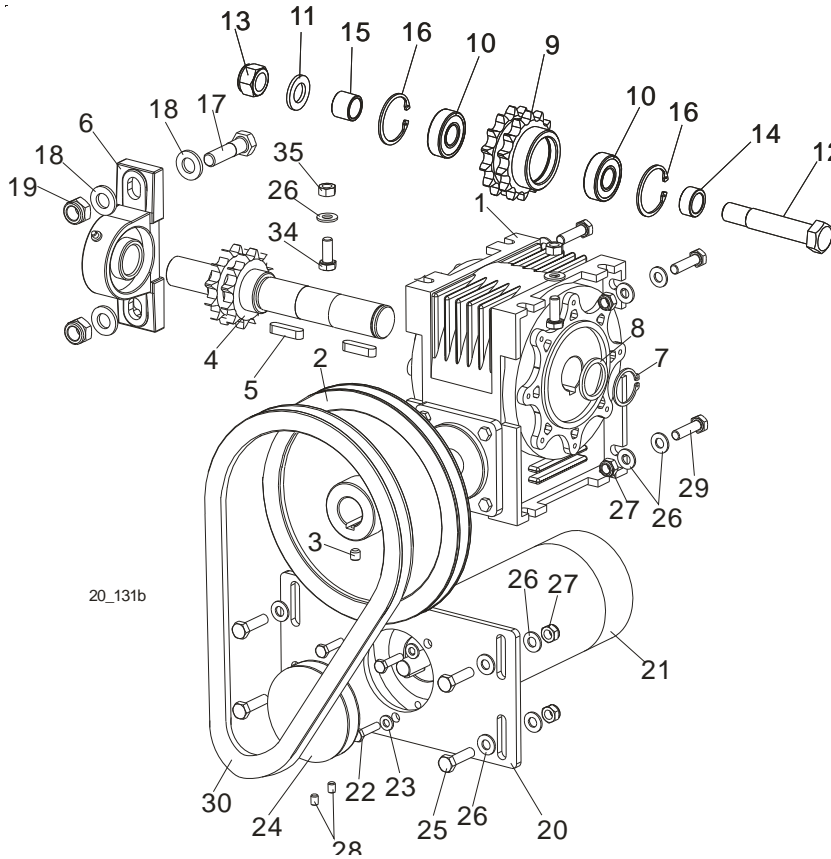

REF.	DESCRIPTION (◆ Indicates Parts Available In Assemblies Only)	PART #	QTY.	
	MOTOR ASSEMBLY, LT20 DC UP/DOWN	098346	1	◆
	Motor Assembly, LT20 Up/Down	098299	1	
1	Box, R-63/66/F1/B3 Gear	097786	1	
2	Pulley, LT20	091078-1	1	
3	Screw, M8x8-33H Hex Socket Set Flat Point	F81014-1	1	
4	Shaft, LT20 Up/Down w/Sprocket	512249-1	1	
5	Key, A8x7x32 Parallel	088564	2	
6	Bearing Assembly, UCP 205CX	088468	1	
7	Ring, Z28 Outside Retaining	F81090-12	1	
8	Washer	098351	1	
	Sprocket Assembly	512276	2	
9	Sprocket, ULMER T08260	512247-1	1	
10	Spacer, Drive Bearing	098166	2	
11	Washer, 17 Flat Zinc	F81058-1	2	
12	Pin, Up/Down Drive Shaft	098289-1	1	
13	Nut, M16-8 Hex Nylon Zinc Lock	F81036-2	1	
14	Bushing, D42 Belt Tensioner Spacer Zinc-pl.	087965-1	1	
15	Bushing, Up/down Sprocket Spacer Zinc-pl.	088792-1	1	
16	Ring, W40 Inside Retaining	F81090-3	2	
17	Bolt, M12x45-8.8 Hex Head Zinc	F81004-32	2	
18	Washer, 13 Flat Zinc	F81056-1	4	

19	Nut, M12-8 Hex Nylon Zinc Lock	F81034-2	2	
	Motor Assembly, LT20 DC Up/Down	091303	1	
20	Plate, LT20 DC Up/Down Motor Mount	098363-1	1	
21	Motor, 0.5HP 12V DC Up/Down & Power Feed	006747	1	
	Brush Kit, 0.5/0.75HP 12VDC	061794		
22	Bolt, M6x25 -5.8 Hex Head Full Thread Zinc	F05005-1	3	
23	Washer, 6.4 Flat Zinc	F81053-1	3	
24	Pulley, "A" SR. 82/12.7	093158-1	1	
25	Bolt, M8x30-5.8 Hex Head Full Thread Zinc	F81002-2	4	
26	Washer, 8.4 Flat Zinc	F81054-1	18	
27	Nut, M8-8-B Hex Nylon Zinc Lock	F81032-2	8	
28	Screw, M6x8 Hex Socket Set Flat Point Zinc	F81013-1	2	
29	Bolt, M8x30-8.8-B Hex Head Full Thread Zinc	F81002-7	4	
30	V-Belt, HA-800 (Kleberg)	091086	1	

5.3 Up/Down Chain Tensioner Assembly

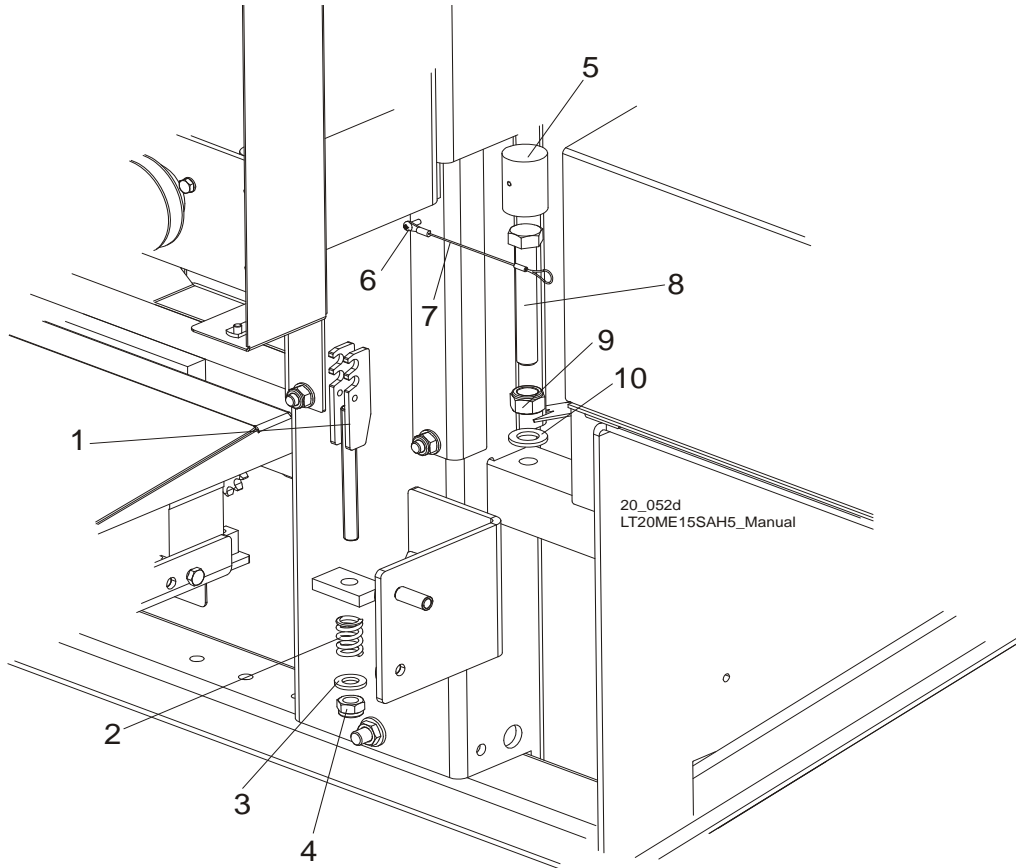

REF.	DESCRIPTION (◆ Indicates Parts Available In Assemblies Only)	PART #	QTY.
1	TENSIONER WELDMENT, LT20 UP/DOWN CHAIN ZINC-PLATED	512259-1	1
2	SPRING, 14 X 30 X 3.2	090797	1
3	WASHER, 13 ZINC FLAT	F81056-1	1
4	NUT, M12-8 HEX NYLON ZINC LOCK	F81034-2	1
	BLOCK, HEAD SUPPORTING, COMPLETE	097775	1
5	Block, Head Support	097771-1	1
6	Screw, M4x12-5.8-B Cross Recessed Pan Head Zinc	F81011-43	1
7	Lanyard, 3/64 x 6	016030	1
8	BOLT, M16X110-8.8 HEX HEAD ZINC	F81006-24	1
9	NUT, M16-8 HEX NYLON ZINC LOCK	F81036-2	1
10	WASHER, 17 FLAT ZINC	F81058-1	1
	CHAIN, LT20 UP/DOWN TYPE 10B-2-111 LINKS	512641	1

5.4 Battery Box Assembly, DC Mills

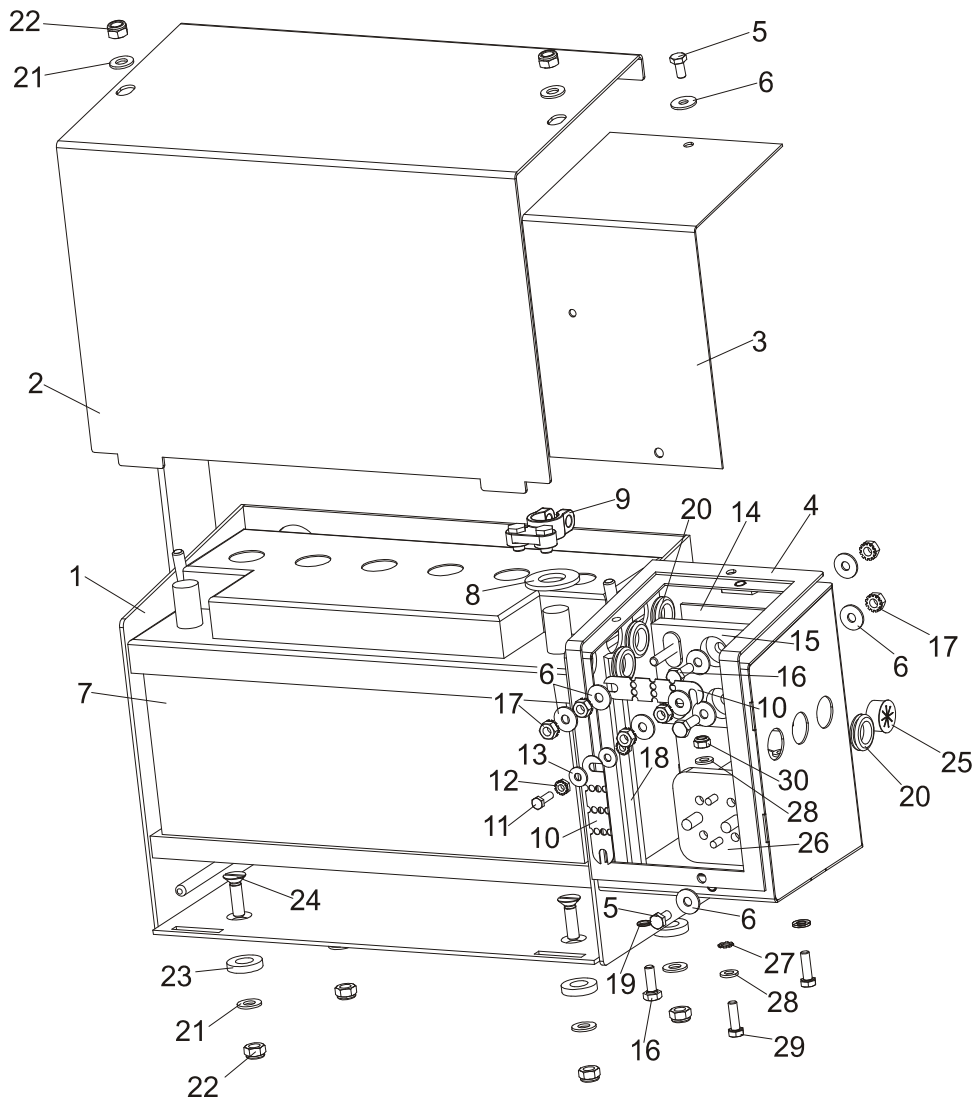

REF.	DESCRIPTION (◆ Indicates Parts Available In Assemblies Only)	PART #	QTY.
	BATTERY BOX, LT20 COMPLETE	097490	1
1	Battery Box, LT20	097486-1	1
2	Lid, Battery Box	097489-1	1
3	Lid, Fuse Box	092222-1	1
4	Gasket, Fuse Box	092226	1
5	Bolt, M6x12-8.8 Hex Head Full Thread Zinc	F81001-7	2
6	Washer, 6.5 Split Lock Zinc	F81053-11	10
7	Battery, "Banner" 12V 100Ah #95751	088323	1
8	Washer, Battery Terminal	P12161	1
9	Terminal, Battery	P05085	1
10	Fuse, 150A 12V Link	023361	2
11	Screw, 10-24x5/8 Unsl Indent HH Machine	F05004-18	1
12	Nut, #10-24 Keps	F05010-14	2
13	Washer, 5.5 Split Lock Zinc	F81052-3	2
14	Plate, 1/8 Plasic Fuse Box	015287	1

15	Block Assy, Fuse, High Amp	017665	1	
16	Bolt, 1/4-20x3/4 FT HHC	F05005-1	3	
17	Nut, 1/4-20 Self Locking Zinc	F05010-9	6	
18	Nut, Fuse Stud Extended	015517	1	
19	Washer, Z6.1 Split Lock Zinc	F81053-3	1	
20	Grommet, 5/8 ID Rubber	P11764	3	
	Grommet, SR170P No.462041	098816	1	
21	Washer, 8.4 Flat Zinc	F81054-1	6	
22	Nut, M8-8-B Hex Nylon Zinc Lock	F81032-2	6	
23	Spacer, SR 1941 Idler	R80671-5	4	
24	Screw, M8x30-5.8-B Zinc	F81002-37	4	
25	Grommet, Heyco Wire	P04137	1	
26	Solenoid, 200A 12V SPST Hyd. Pump 1997	015470	1	
27	Washer, 6.4 Star Lock Zinc	F81053-2	1	
28	Washer, 6.4 Flat Zinc	F81053-1	4	
29	Bolt, M6x20-8.8 Hex Head Full Thread Zinc	F81001-2	2	
30	Nut, M6-8-B Hex Nylon Lock Zinc	F81031-2	2	

SECTION 6 UP/DOWN ROLLERS & BLADE HEIGHT SCALE

6.1 Up/Down Rollers

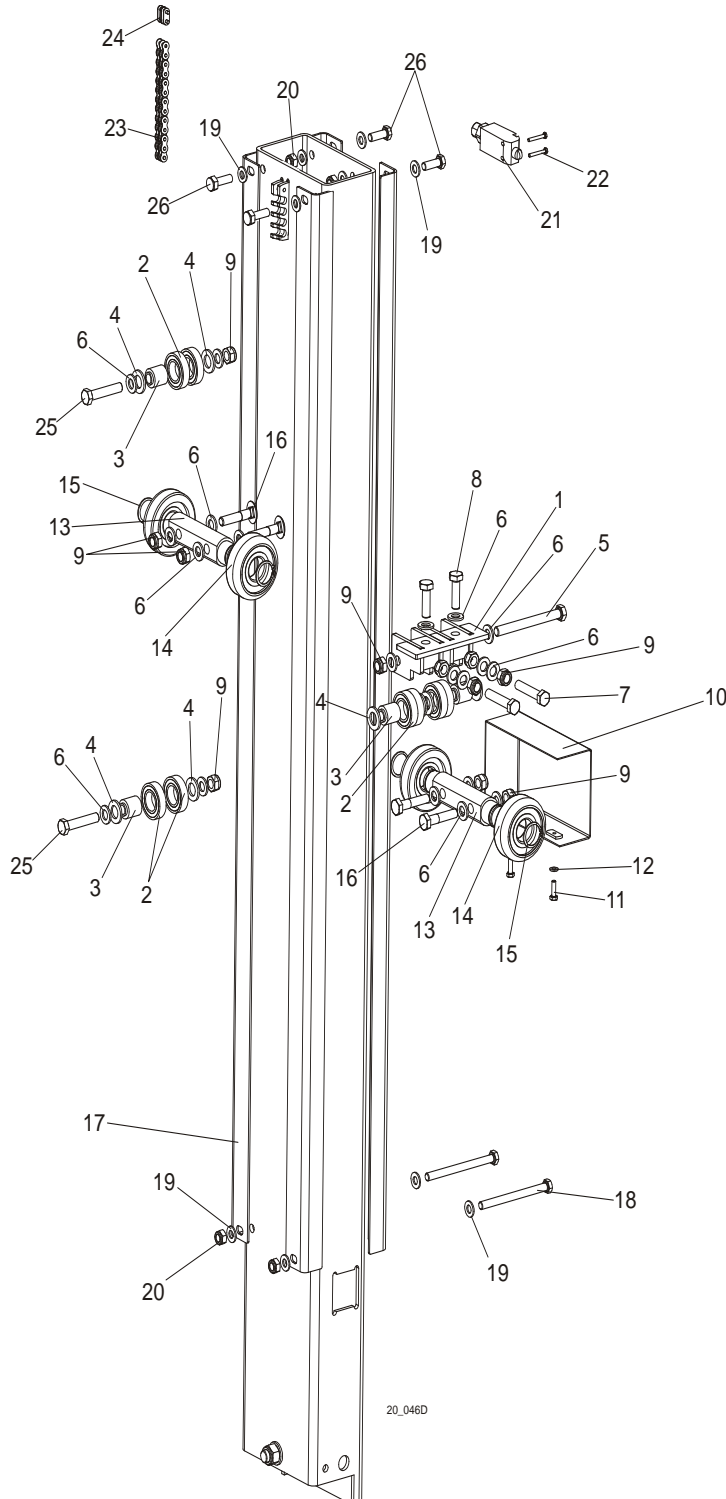

20_046D

REF.	DESCRIPTION (◆ Indicates Parts Available In Assemblies Only)	PART #	QTY.
1	BRACKET WELDMENT, LT20 UP/DOWN ROLLER PTD	091095-1	1
2	BEARING, 6005 2RS CX	089652	8

3	BUSHING, LT20 UP/DOWN ROLLER	090790	4	
4	WASHER, 17 ZINC FLAT	F81058-1	10	
5	BOLT, M12 X 120 8.8 HEX HEAD ZINC	F81004-38	1	
6	WASHER, 13 ZINC FLAT	F81056-1	20	
7	BOLT, M12 X 60-8.8 HEX HEAD FULL THREAD ZINC	F81004-51	2	
8	BOLT, M12 X 40-8.8 HEX HEAD FULL THREAD ZINC	F81004-4	2	
9	NUT, M12-8 HEX NYLON ZINC LOCK	F81034-2	11	
10	GUARD, LT20 UP/DOWN ROLLERS PTD	091619-1	1	
11	BOLT, M6 X 20-8.8 HEX HEAD FULL THREAD ZINC	F81001-2	2	
12	WASHER, 6.4 ZINC FLAT	F81053-1	2	
13	SHAFT, UP/DOWN ROLLER ZINC-PLATED	090616-1	2	
14	ROLLER, CBK-468	088433	4	
15	RING, Z30 SPRING RETAINING	F81090-23	4	
16	BOLT, M12 X 55-8.8 HEX HEAD FULL THREAD ZINC	F81004-43	4	
17	ANGLE, LT20 MAST TUBE	091182	4	
18	BOLT, M10 X 125-8.8 HEX HEAD ZINC	F81003-18	2	
19	WASHER, 10.5 ZINC FLAT	F81055-1	22	
20	NUT, M10-8-B HEX NYLON ZINC LOCK	F81033-1	10	
21	SWITCH, GLCB01C LIMIT	100910	1	
22	BOLT, M4 X 30 8.8 HEX HEAD FULL THREAD ZINC	F81011-5	2	
23	CHAIN, LT20 UP/DOWN TYPE 10B-2-111 LINKS	512641	1	
24	LINK, 10B-2Pz	088673	1	
25	BOLT, M12X60-8.8 HEX HEAD ZINC	F81004-5	2	
26	BOLT, M10X25-8.8 HEX HEAD FULL THREAD ZINC	F81003-11	4	

6.2 Blade Height Scale

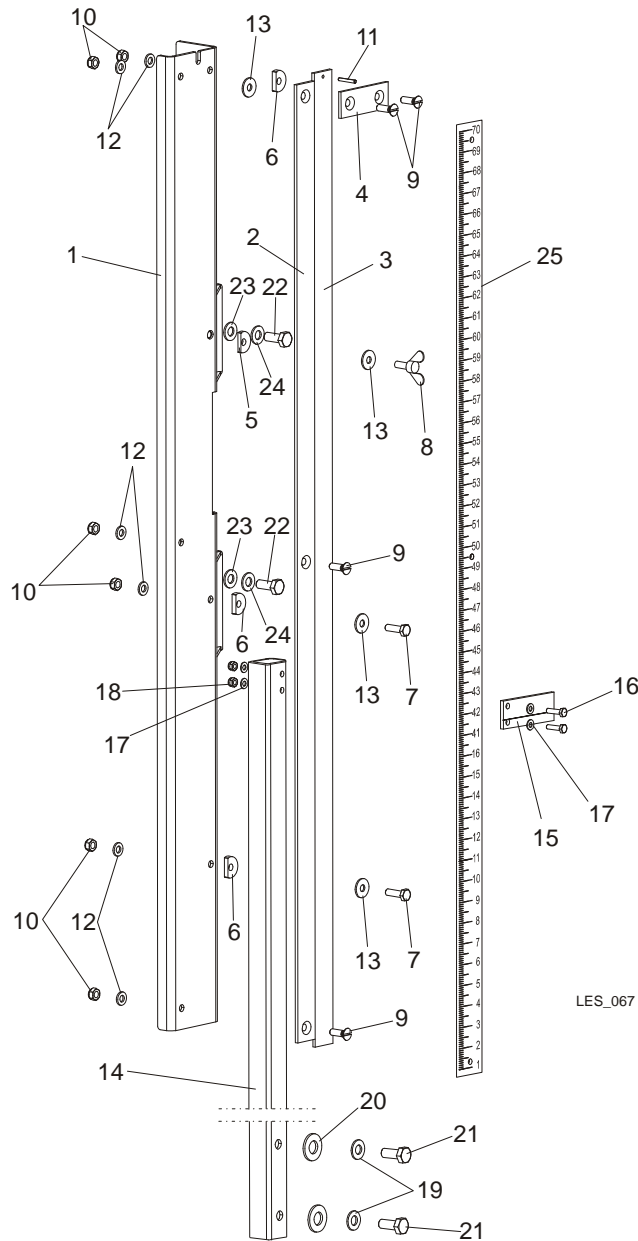

REF.	DESCRIPTION (◆ Indicates Parts Available In Assemblies Only)	PART #	QTY.
	SCALE, LT20B SPECIAL W/INDICATOR COMPLETE	503050	1
	SCALE, LT20B SPECIAL COMPLETE	503046	1
1	BRACKET, SCALE MOUNT PTD	503047-1	1
2	BAR, SCALE	092750	1
3	BAR, INCH SCALE	093133	1
4	BAR, SCALE MOUNT	093134	1
5	WASHER, 6.2X20X3.5 SPECIAL	503096	1
6	WASHER, 6.2X20X4.5 SPECIAL	503098	3
7	BOLT, M6X20-8.8 HEX HEAD FULL THREAD ZINC	F81001-2	2
8	BOLT, M6X16 BN276	F81001-16	1
9	SCREW, M6X20-4.8-B FE/ZN5 PN-85/M-82207	F81001-31	4

10	NUT, M6-8-B HEX NYLON LOCK ZINC	F81031-2	6	
11	PIN, 3X20 ROLL ZINC	F81044-5	1	
12	WASHER, 6.4 FLAT ZINC	F81053-1	9	
13	WASHER, 6.5 SPECIAL FLAT ZINC	F81053-11	2	
	INDICATOR, LT20B CUTTING HEIGHT SPECIAL COMPLETE	503095	1	
14	BRACKET, SCALE INDICATOR MOUNT PTD	503049-1	1	
15	INDICATOR, BLADE HEIGHT SCALE	094821	1	
16	BOLT, M5x16-8.8 HEX HEAD ZINC	F81000-20	2	
17	WASHER, 5.3 FLAT ZINC	F81052-1	4	
18	NUT, M5-8-Fe/Zn5 DIN985	F81030-2	2	
19	WASHER, 8.4 FLAT ZINC	F81054-1	2	
20	WASHER, 8.2 SPLIT LOCK ZINC	F81054-4	2	
21	BOLT, M8 X 45 - 8.8 HEX HEAD FULL THREAD ZINC	F81002-14	2	
22	BOLT, M8 X 20-5.8 HEX HEAD FULL THREAD ZINC	F81002-1	2	
23	WASHER, 8.5 SPECIAL ZINC	F81054-11	2	
24	WASHER, 8.2 SPLIT LOCK ZINC	F81054-4	2	
25	DECAL, LT20 0-80CM METRIC SCALE	091239	1	
	DECAL, 45-63MM METRIC	P12040-2	1	
	DECAL, 16-40MM METRIC	P12040-1	1	

6.3 Limit Switches

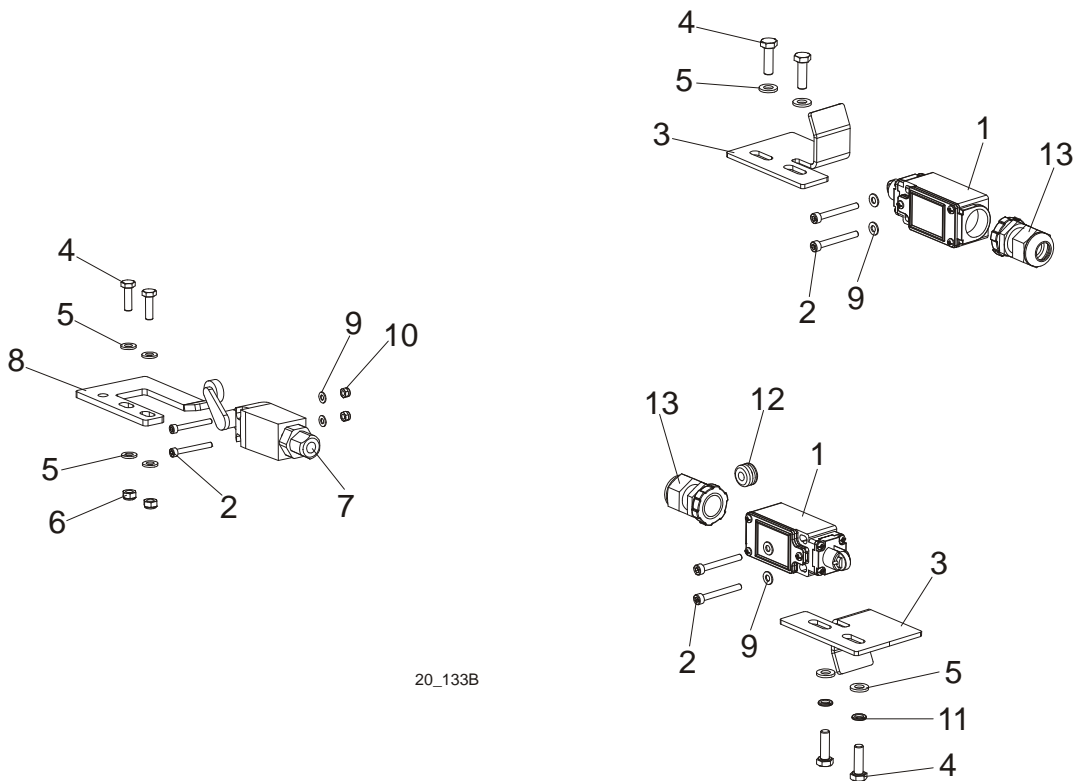

20_133B

REF	DESCRIPTION (◆ Indicates Parts Available In Assemblies Only)	PART #	QTY.
1	SWITCH, GLCB01C LIMIT	100910	2
2	SCREW, M4x35-8.8 HEX SOCKET HEAD CAP ZINC	F81011-34	6
3	BRACKET, LIMIT SWITCH	091682-1	2
4	BOLT, M6X20-8.8 HEX HEAD FULL THREAD ZINC	F81001-2	6
5	WASHER, 6.4 FLAT ZINC	F81053-1	8
6	NUT, M6-8-B HEX NYLON ZINC LOCK	F81031-2	2
7	SWITCH, GLCB01A1B LIMIT	100931	1
8	BRACKET, LIMIT SWITCH	091852-1	1
9	WASHER, 4.3 FLAT ZINC	F81051-2	6
10	NUT, M4-B HEX NYLON ZINC LOCK	F81029-1	2
11	WASHER, Z6.1 SPLIT LOCK ZINC	F81053-3	2
12	GROMMET, RUBBER INSIDE DIA 6mm	085338	1
13	STUFFING-BOX, SKINTOP PG 13,5	086524	2



SECTION 7 POWER FEED & TRACK ROLLERS

7.1 Power Feed Assembly, AC Mills

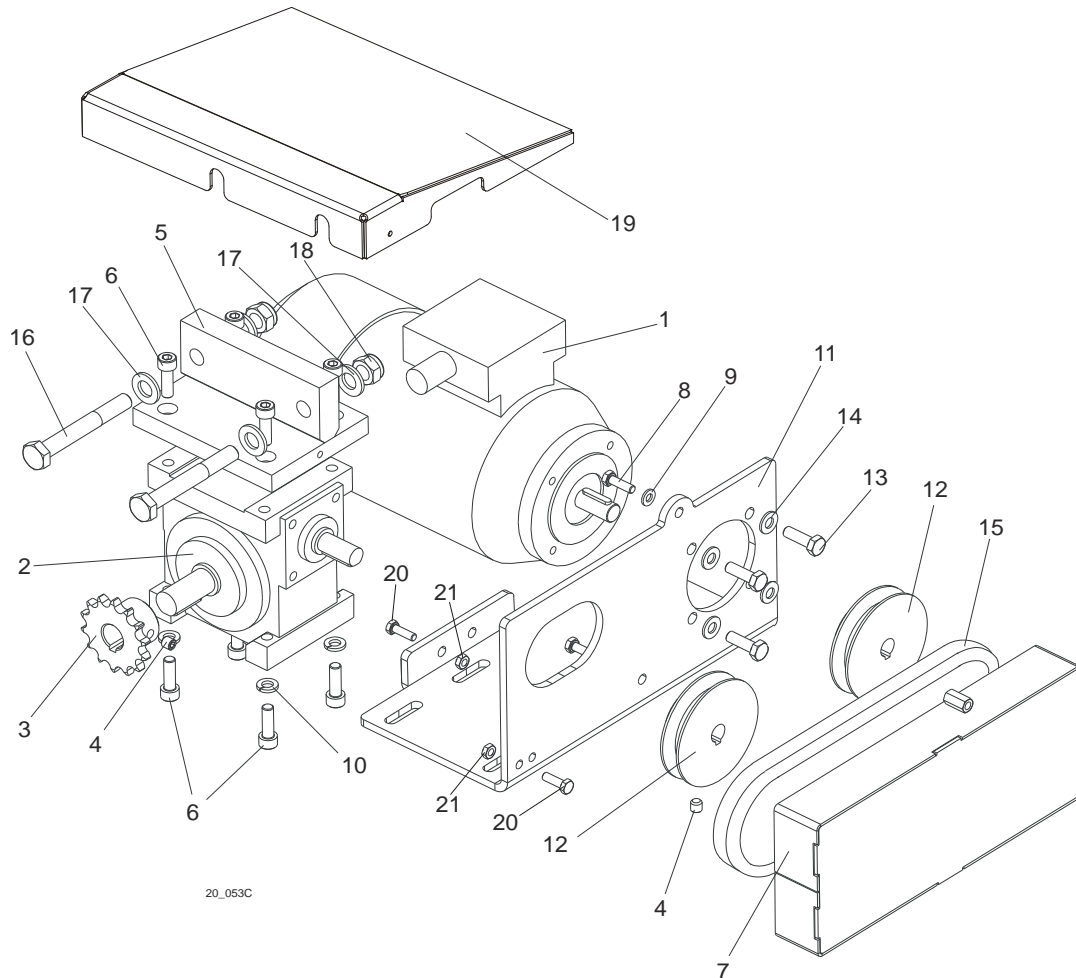

REF.	DESCRIPTION (◆ Indicates Parts Available In Assemblies Only)	PART #	QTY.
	POWER FEED ASSEMBLY, LT20 AC	091196	1
1	Motor, Kh71X-2C2, RAL 9005	097313	1
2	Gear Box, RA-04/7.5/D1/N+S/B8 w/Output Shaft	090698	1
3	Sprocket, 08B Z14 Zinc-plated	090702-1	1
4	Screw, M8x8-33H Hex Socket Set Flat Point Zinc	F81014-1	1
5	Bracket, Power Feed Gear Box Mount	090715-1	1
6	Screw, M8X25-8.8 Hex Socket Head Cap Zinc	F81002-21	4
7	Guard, Power Feed Drive Belt	091195-1	1
8	Bolt, M6x20-8.8 Hex Head Full Thread Zinc	F81001-2	2
9	Washer, 6.4 Zinc Flat	F81053-1	2
10	Washer, 8.2 Split Lock Zinc	F81054-4	4
11	Bracket, Power Feed Gear Box	091191	1
12	Pulley, LT20 Power Feed Gear Box Ptd	090699-1	2
13	Bolt, M6x20-8.8-B Hex Head Full Thread Zinc	F81001-2	4
14	Washer, 6.1 Split Lock Zinc	F81053-3	4
15	V-Belt, HA-560 (STOMIL-SANOK)	088562	1

16	BOLT, M12X90-8.8 HEX HEAD ZINC	F81004-2	2	
17	WASHER, 13 ZINC FLAT	F81056-1	4	
18	NUT, M12-8 HEX NYLON ZINC LOCK	F81034-2	2	
19	GUARD, POWER FEED MOTOR	093780-1	1	
20	BOLT, M8 x 25mm HEX HEAD GR 5.8 ZINC	F81002-5	2	
21	NUT, M8 HEXAGON, GRADE 5.8 FREE ZINC	F81032-1	2	

7.2 Power Feed Assembly, DC Mills

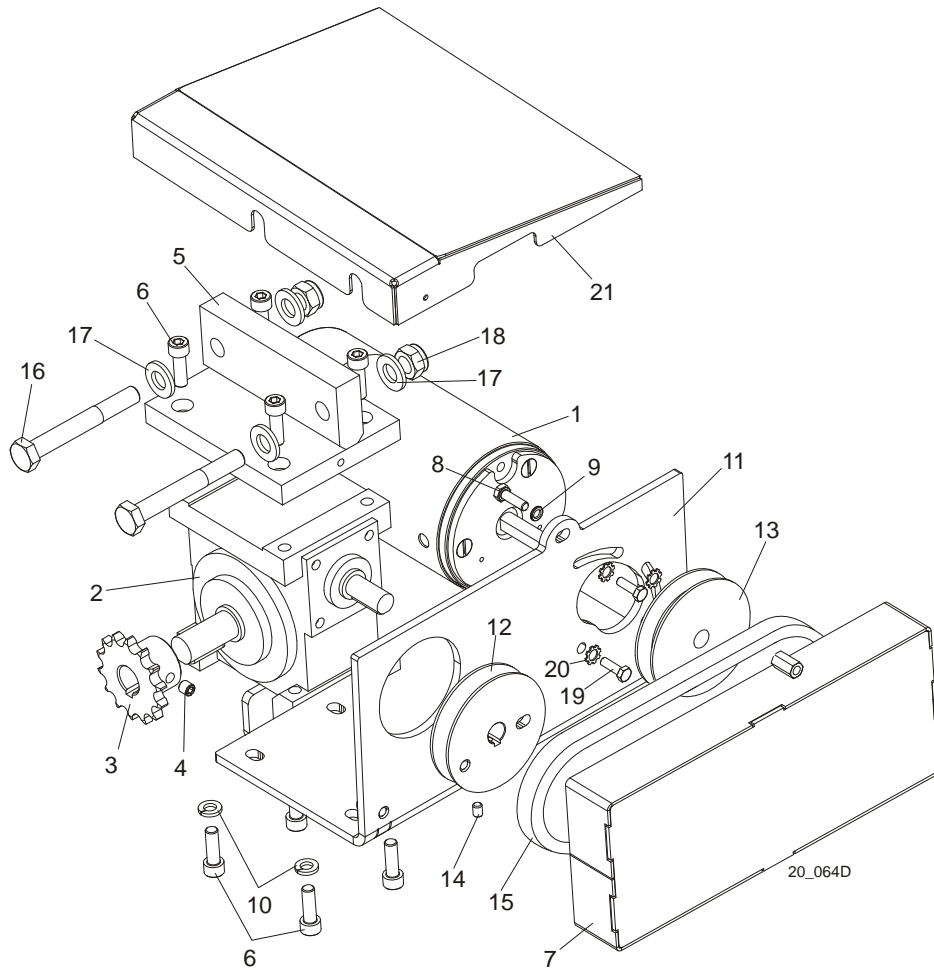

REF.	DESCRIPTION (◆ Indicates Parts Available In Assemblies Only)	PART #	QTY.
	POWER FEED ASSEMBLY, LT20 DC	090703	1
1	Motor, 12V 0.5HP	006747	1
	Brush Kit, 1/2 HP 12V DC	061794	
2	Gear Box, RA-04/7.5/WBS/i1/N+S/B8 w/Output Shaft	090698	1
3	Sprocket, 10B Z14 Zinc-plated	090702-1	1
4	Screw, M8x8-33H Hex Socket Set Flat Point Zinc	F81014-1	1
5	Bracket, Power Feed Gear Box Mount	090715-1	1
6	Screw, M8X25-8.8 Hex Socket Head Cap Zinc	F81002-21	4
7	Guard, Power Feed Drive Belt	091195-1	1
8	Bolt, M6x20-8.8 Hex Head Full Thread Zinc	F81001-2	2
9	Washer, M6 Split Lock Zinc	F81053-3	2
10	Washer, 8.2 Split Lock Zinc	F81054-4	4
11	Plate, LT20 Power Feed Motor Mount Ptd	502550-1	1
12	Pulley, LT20 Power Feed Gear Box Ptd	090699-1	2
13	Sheave, Up/Down Motor "A" 82/12.7 Ptd	093158-1	1
14	Screw, M6x8 Hex Socket Set Cone Point Zinc	F81013-1	3
15	V-Belt, HA-560 (STOMIL-SANOK)	088562	1
16	Bolt, M12x90-8.8 Hex Head Zinc	F81004-2	2
17	Washer, 13 Zinc Flat	F81056-1	4

18	Nut, M12-8 Hex Nylon Zinc Lock	F81034-2	2	
19	Bolt, 1/4-20x3/4 FT HHC	F05005-1	3	
20	Washer, M6 Star Lock Zinc	F81053-2	3	
21	GUARD, POWER FEED MOTOR	093780-1	1	

7.3 Upper Track Rollers And Wipers

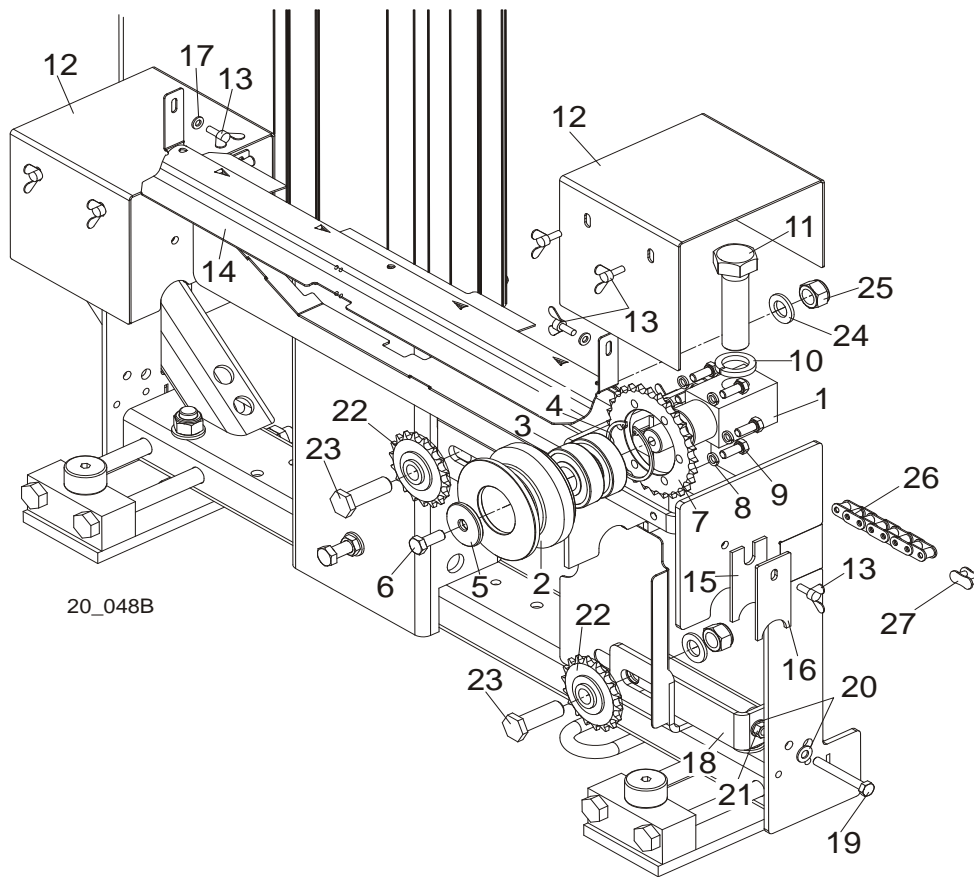

REF.	DESCRIPTION (◆ Indicates Parts Available In Assemblies Only)	PART #	QTY.
	ROLLER ASSEMBLY, LT20 UPPER TRACK	090662	2
1	Block, Upper Track Roller Mount	090665	1
2	Roller, Upper Track	090663	1
3	Bearing, 6305 2RS NSK	P08066	2
4	Ring, 2 7/16" Bevelled Snap	F04254-21	1
5	Washer, Drive Wheel	086286	1
6	Bolt, M10x25-8.8 Hex Head Full Thread Zinc	F81003-11	1
7	Sprocket, O8B Z28	090664	2
8	Washer, 8.2 Split Lock Zinc	F81054-4	6
9	Bolt, M8x20-5.8 Hex Head Full Thread Zinc	F81002-1	6
10	WASHER, Z 24.5 SPLIT LOCK ZINC	F81061-4	2
11	BOLT, M24X2X90-8.8 HEX HEAD FULL THREAD ZINC	F81009-2	2
12	GUARD, UPPER TRACK ROLLER	090749-1	2
13	SCREW, M6 X 16 BN276 DIN 316 THUMB	F81001-16	8
14	COVER, LT20 MIDDLE TRACK W/FELT - SERVICE	091656-S	1
	Cover, LT20 Middle Track Ptd	091656-1	1
	Strip, 3/16 X 2 X 23 Felt	S09915	1
15	WIPER, TOP RAIL	M04113	2
16	PLATE, TRACK WIPER PTD	088559-1	2
17	WASHER, 6.4 ZINC FLAT	F81053-1	2

18	TENSIONER, POWER FEET SPROCKET	092862-1	1	
19	BOLT, M8 X 65MM,HH,GRADE 5.8, ZINC	F81002-3	1	
20	WASHER, M8, FLAT, ZINC	F81054-1	2	
21	NUT, M8 HEXAGON,GRADE 5.8 FREE ZINC	F81032-1	1	
22	SPROCKET, IDLER Z=18 KSR16.L0.08.10.18.0	088700	2	
23	BOLT, SPROCKET MOUNT	091744-1	2	
24	WASHER, 17 FLAT ZINC	F81058-1	2	
25	NUT, M16,HEX, NYLON ZINC LOCK	F81036-2	2	
26	CHAIN, LT20 08B-185 TYPE POWER FEED	091624	1	
27	LINK, 08B-1PZ MASTER	091625	1	

7.4 Lower Track Rollers

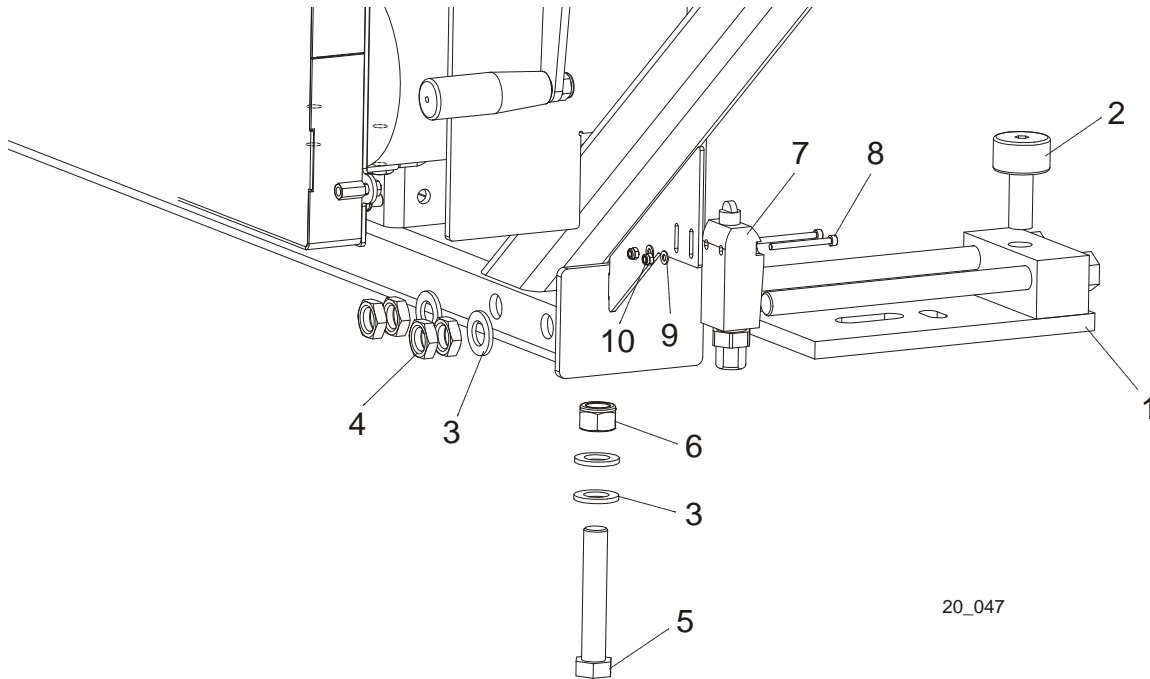

REF.	DESCRIPTION (◆ Indicates Parts Available In Assemblies Only)	PART #	QTY.
	ROLLER ASSEMBLY, LT20 LOWER TRACK	090670	2
1	Bracket, LT20 Lower Track Roller	090671-1	1
2	Bearing, Cam Follower (McGill)	012797	1
3	WASHER, 17 ZINC FLAT	F81058-1	4
4	NUT, M16 HEX THIN ZINC	F81036-4	4
5	BOLT, M16 X 90-8.8 HEX HEAD ZINC	F81006-17	1
6	NUT, M16-8 HEX NYLON ZINC LOCK	F81036-2	1
7	SWITCH, GLCB01A1B LIMIT	100931	1
8	SCREW, M4 X 45-8.8 HEX SOCKET HEAD CAP ZINC	F81011-33	2
9	NUT, M4-B HEX NYLON ZINC LOCK	F81029-1	2
10	WASHER, 4.3 ZINC FLAT	F81051-2	2

SECTION 8 BED FRAME ASSEMBLY

8.1 Bed Section

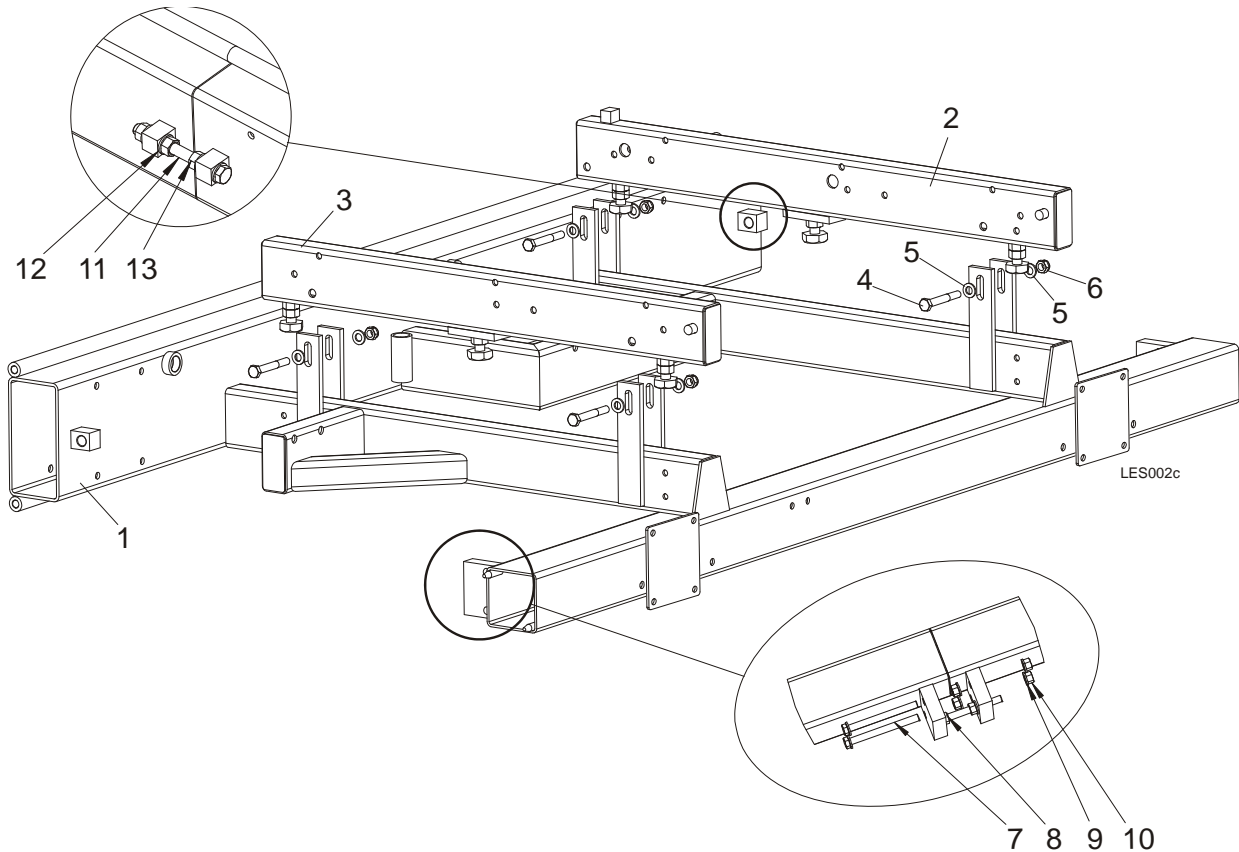

REF	DESCRIPTION (◆ Indicates Parts Available In Assemblies Only)	PART #	QTY.
1	BED SECTION, LES COMPLETE	099710-1	1
2	Tube Wldmt, Bed, LT80 Long	089385	1
3	Tube Wldmt, Bed, LT80 Short	089386	1
4	Bolt, M12 x 90-8.8 Hex Head Zinc	F81004-2	4
5	Washer, 13 SAE Flat	F81056-1	8
6	Nut, M12-8 Hex Nylon Zinc Lock	F81034-2	4
7	BOLT, M12X130-8.8 HEX HEAD ZINC	F81004-55	2
8	BOLT, M12X100-8.8 HEX HEAD ZINC	F81004-45	1
9	WASHER, 13 SAE FLAT	F81056-1	7
10	NUT, M10-8-B HEX NYLON ZINC LOCK	F81033-1	5
11	BOLT, M16X160-8.8 HEX HEAD ZINC	F81006-23	1
12	WASHER, 17 FLAT ZINC	F81058-1	4
13	NUT, M16-5.8 HEX ZINC	F81036-1	3

8.2 Bed Section, Additional

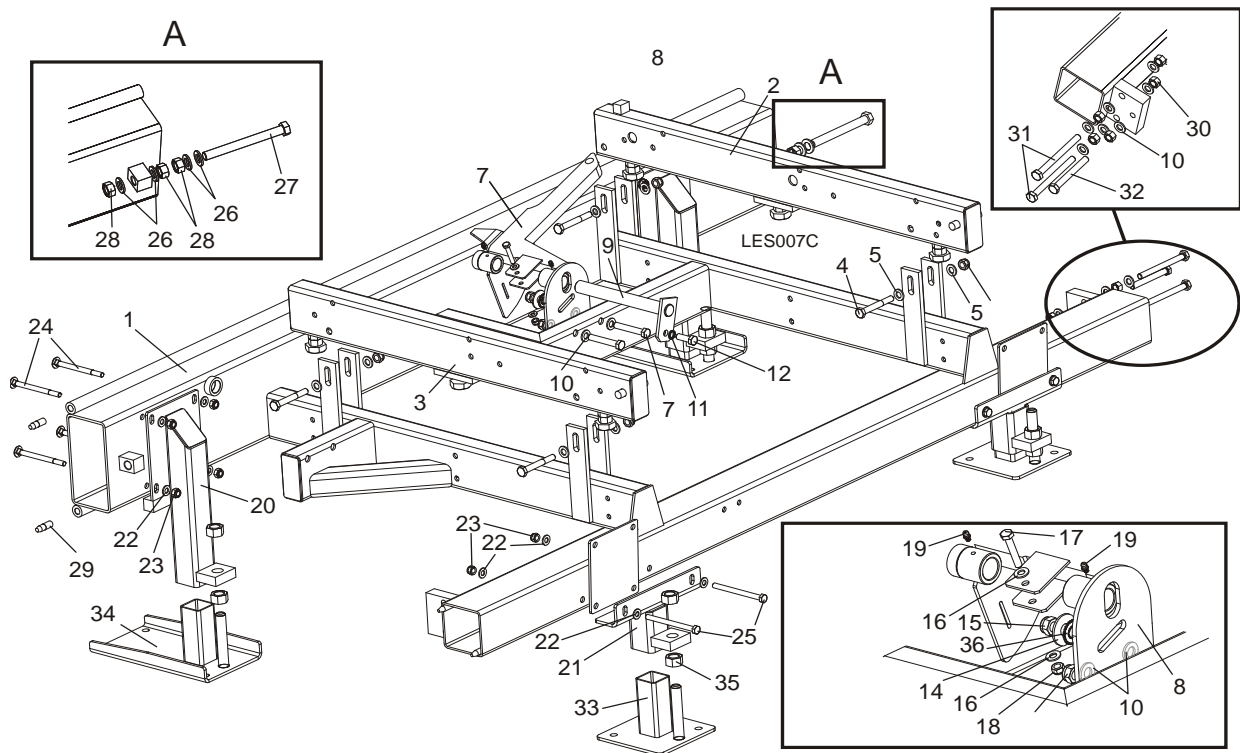

REF.	DESCRIPTION (◆ Indicates Parts Available In Assemblies Only)	PART #	QTY.
	BED SECTION, LES ADDITIONAL	101061-S	1
1	BED FRAME SECTION,	099710-1	1
2	Tube Wldmt, Bed, LT80 Long	089385	1
3	Tube Wldmt, Bed, LT80 Short	089386	1
4	Bolt, M12 x 90-8.8 Hex Head Zinc	F81004-2	4
5	Washer, 13 Flat Zinc	F81056-1	8
6	Nut, M12-8 Hex Nylon Zinc Lock	F81034-2	4
7	SUPPORT, PTD SIDE W/GUARD	099785-1	1
8	PLATE, LOG SIDE SUPPORT MOUNT PTD	091591-1	1
9	PIN, SIDE SUPPORT ZINC-PLATED	091549-1	1
10	WASHER,13 FLAT ZINC	F81056-1	11
11	WASHER, SERRATED BN781 M12/13	F81056-16	1
12	BOLT, M12 X 35-8.8-FE/ZN5 HEX HEAD FULL	F81004-24	1
13	BOLT, M12 X 75-8.8 HEX HEAD ZINC	F81004-21	2
14	WASHER, 15 FLAT SPECIAL ZINC-PLATED	F81057-3	1
15	NUT, M12-8 HEX NYLON ZINC LOCK	F81034-2	3
16	WASHER, 8.4 FLAT ZINC	F81054-1	2
17	BOLT, M8 X 45 - 8.8 HEX HEAD FULL THREAD ZINC	F81002-14	1
18	NUT, M8-8-B HEX NYLON ZINC LOCK	F81032-2	1
19	FITTING, 3/16X3/16 STRAIGHT GREASE	P04107	2
20	SUPPORT, HIGH LES	100559-1	2

21	SUPPORT, LOW LES	100553-1	2	
22	WASHER, 10.5 FLAT ZINC	F81055-1	16	
23	NUT, M10-8-B NYLON HEX ZINC LOCK	F81033-1	12	
24	BOLT, M10X120 8.8 FE/ZN5	F81003-33	8	
25	BOLT, M10x125-8.8 HEX HEAD ZINC	F81003-18	4	
26	WASHER, 17 FLAT ZINC	F81058-1	4	
27	BOLT, M16x160-8.8 HEX HEAD FULL THREAD ZINC	F81006-23	1	
28	NUT, M16-5.8 HEX ZINC	F81036-1	3	
29	PIN, SPECIAL	090675	2	
30	NUT, M12-8-B ZINC HEX	F81034-1	5	
31	BOLT, M12X130-8.8 HEX HEAD FULL THREAD ZINC	F81004-55	2	
32	BOLT, M12X100 8.8 HEX HEAD FULL THREAD ZINC	F81004-45	1	
33	FOOT, LES TABLE LEG	099281-1	2	
34	FOOT WIDE LES	500775-1	2	
35	NUT, M20-8 HEX ZINC	F81037-1	8	
36	WASHER, SERRATED BN783 M12/12.3/30.3	F81056-17	1	

8.3 Bed Extension

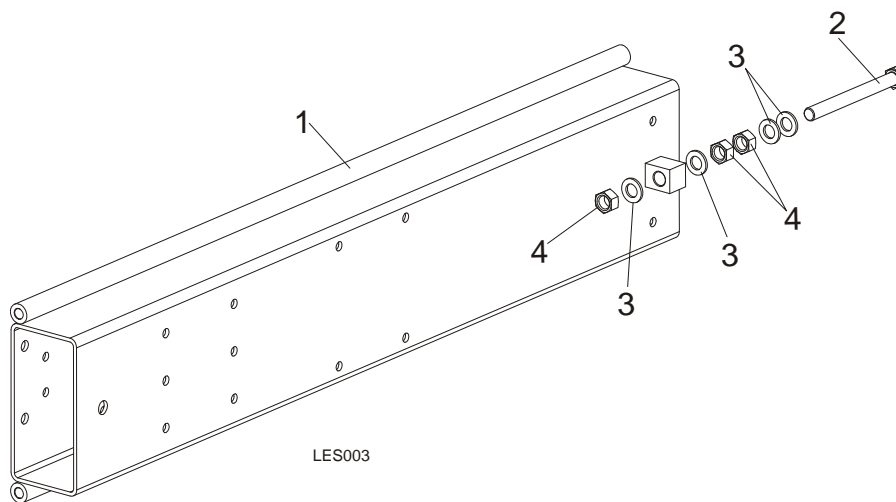

REF.	DESCRIPTION (◆ Indicates Parts Available In Assemblies Only)	PART #	QTY.	
	BED EXTENSION, LES COMPLETE	099729	1	
1	Bed Extension, LES	099728-1	1	
2	Bolt, M16x160-8.8 Hex Head Zinc	F81006-23	1	
3	Washer, 17 Zinc Flat	F81058-1	4	
4	Nut, M16-5.8 Hex Zinc	F81036-1	3	

8.4 Stationary Leg Kit

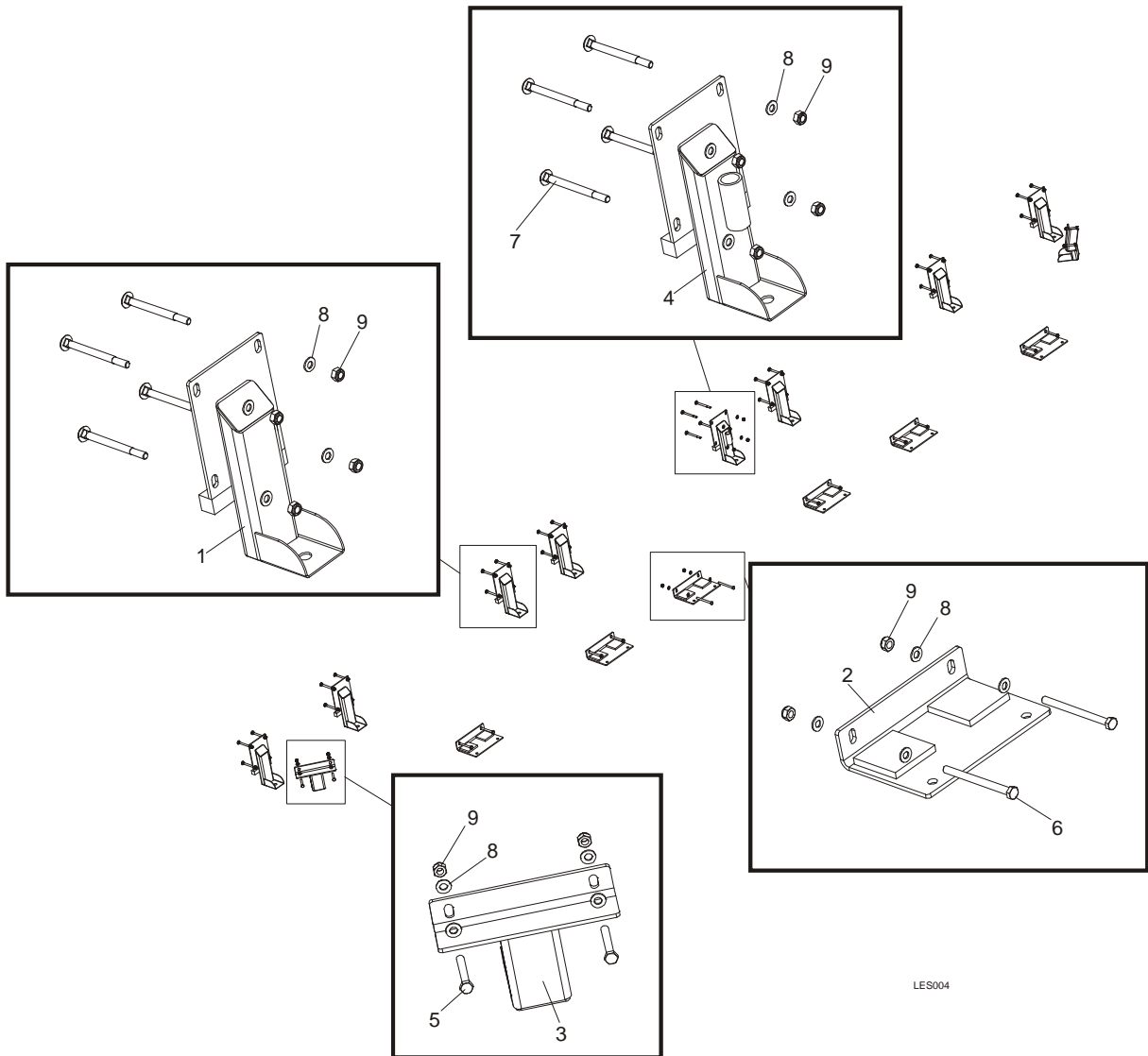

LES004

REF.	DESCRIPTION (◆ Indicates Parts Available In Assemblies Only)	PART #	QTY.	
	KIT, LES STATIONARY LEG (LT20B2)	500802	1	
	KIT, LES STATIONARY LEG (LT20B3)	100864	1	
1	Leg, LES High	100536-1	5/7	
2	Leg, LES Low	100550-1	6	
3	Leg, LES Side	100868-1	2	
4	Leg, LES High w/Bushing	101186-1	1	
5	Bolt, M10X75-8.8 Hex Head Zinc	F81003-15	4	
6	Bolt, M10x125-8.8 Hex Head Zinc	F81003-18	8/12	
7	Bolt, M10X120 8.8 Carriage Head Zinc	F81003-33	24/32	
8	Washer, 10.5 Flat Zinc	F81055-1	52/64	
9	Nut, M10-8-B Hex Nylon Zinc Lock	F81033-1	36/48	

8.5 Outrigger Leg Kit

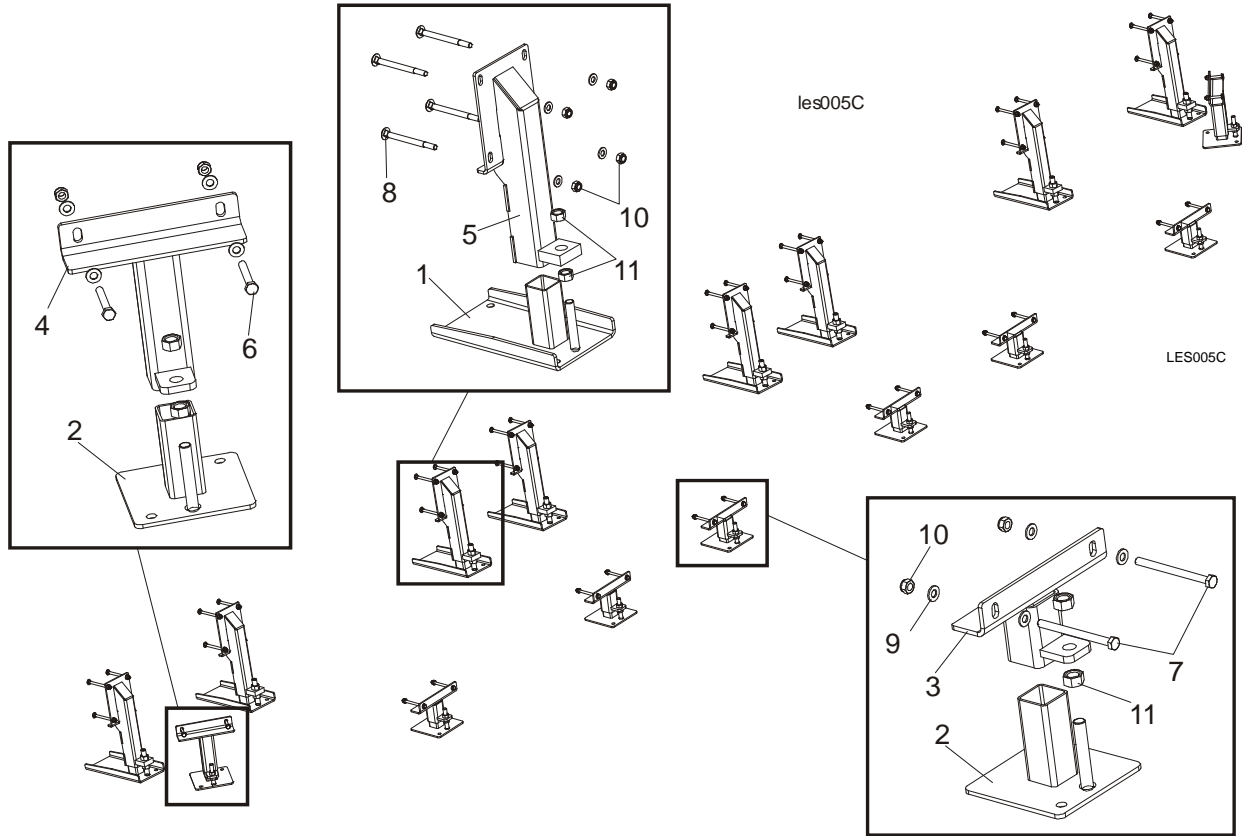

REF.	DESCRIPTION (◆ Indicates Parts Available in Assemblies Only)	PART #	QTY.
	KIT, LES OUTRIGGER LEG (LT20B2)	500803	1
	KIT, LES OUTRIGGER LEG (LT20B3)	100865	1
1	Foot, LES Wide	500775-1	6/8
2	Foot, LES Table Leg	099281-1	6/8
3	Leg, LES Low	100553-1	4/6
4	Leg, LES Side	100554-1	2
5	Leg, LES High	100559-1	6/8
6	Bolt, M10X75-8.8 Hex Head Zinc	F81003-15	4
7	Bolt, M10x125-8.8 Hex Head Zinc	F81003-18	8/12
8	Bolt, M10X120 8.8 Carriage Head Zinc	F81003-33	24/32
9	Washer, 10.5 Flat Zinc	F81055-1	48/64
10	Nut, M10-8-B Hex Nylon Zinc Lock	F81033-1	40/48
11	Nut, M16-5.8 Hex Zinc	F81036-1	32

8.6 Outrigger Leg Kit High - LES B3

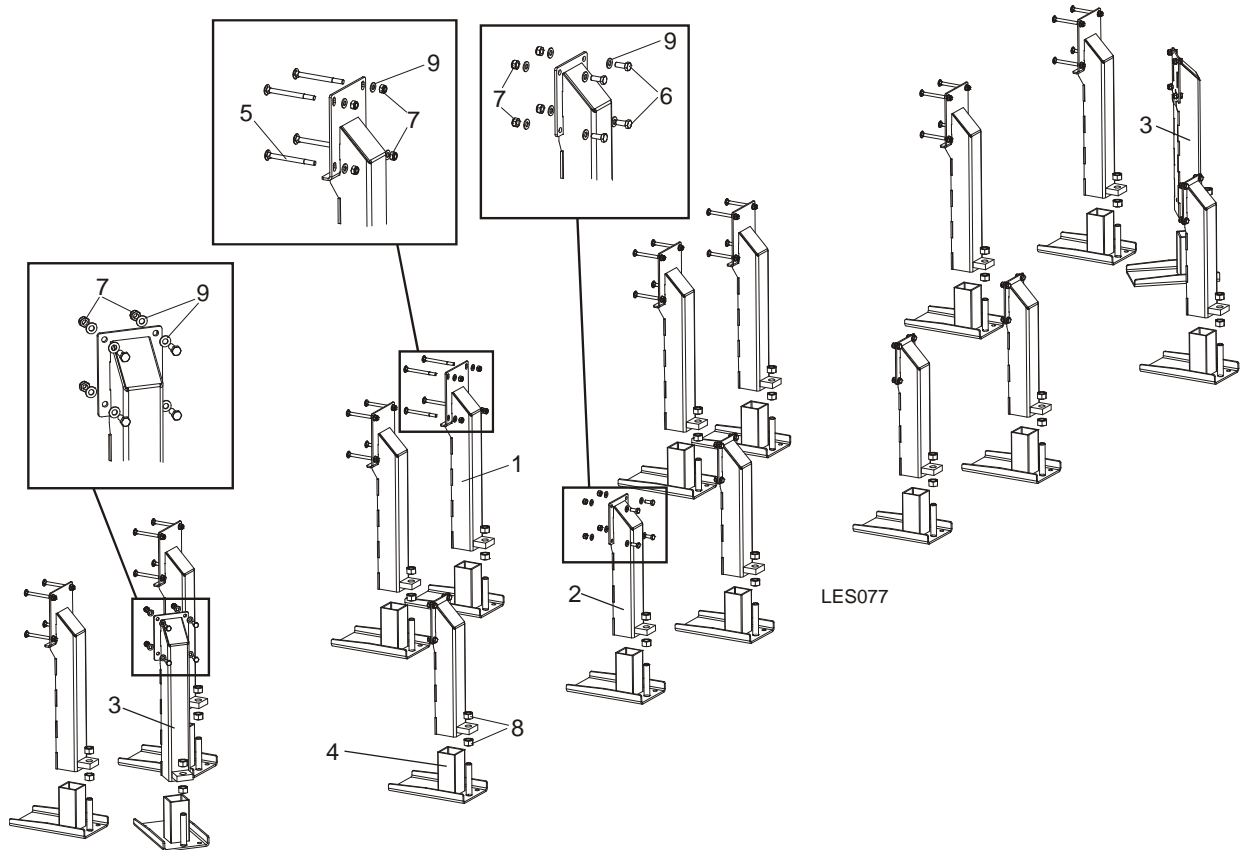

REF.	DESCRIPTION (◆ Indicates Parts Available In Assemblies Only)	PART #	QTY.
	KIT, LES OUTRIGGER LEG HIGH- LES B3	508436	1
1	Leg, LES High Main Tube	507620-1	8
2	Leg, LES Side LT40B/RPA	508435-1	6
3	Leg, LES Side	507715-1	2
4	Foot, LES Wide	501084-1	16
5	Bolt, M10X120 8.8 Carriage Head Zinc	F81003-33	32
6	Bolt, M10x25-8.8 Hex Head Full Thread Zinc	F81003-11	32
7	Nut, M10-8-B Hex Nylon Zinc Lock	F81033-1	64
8	Nut, M20-8 Hex Zinc	F81037-1	32
9	Washer, 10.5 Flat Zinc	F81055-1	96

8.7 Log Side Support Assembly

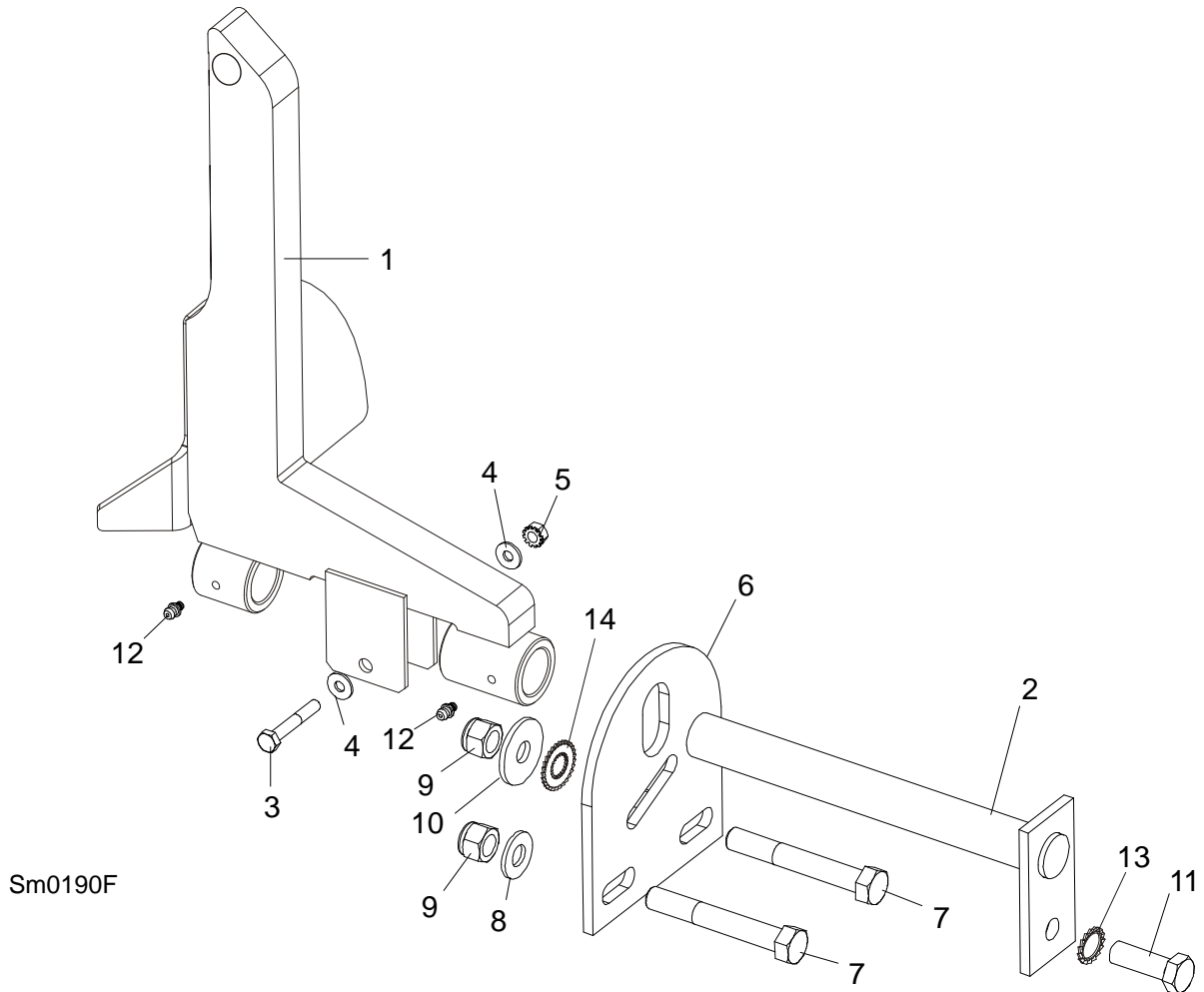

REF.	DESCRIPTION (◆ Indicates Parts Available In Assemblies Only)	PART #	QTY.
	SUPPORT KIT, MANUAL LOG SIDE	092686	1
	LOG SIDE SUPPORT - LT20B	500960	3
1	SUPPORT, LOG SIDE W/GUARD	099785-1	1
2	Pin, Log Side Support Pivot	091549-1	1
3	Bolt, M8x45-8.8 Hex Head Full Thread Zinc	F81002-14	1
4	Washer, 8.4 Flat	F81054-1	2
5	Nut, M8-8-B Self Locking	F81032-2	1
6	Plate, Log Side Support End	091591-1	1
7	Bolt, M12 x 75-8.8 Hex Head	F81004-21	2
8	Washer, 13 Flat	F81056-1	2
9	Nut, M12-8 Hex Nylon Lock	F81034-2	3
10	Washer, 15 Flat Special Zinc-Plated	F81057-3	1
11	Bolt, M12 x 35-8.8 Hex Head	F81004-24	1
12	FITTING, 3/16" GREASE	P04107	2
13	WASHER, SPECIAL BOSART/2S, BN781 M12/13	F81056-16	1
14	WASHER, SPECIAL BOSART/2S M12/12,3/30,3	F81056-17	1

8.8 Front & Rear Tubes

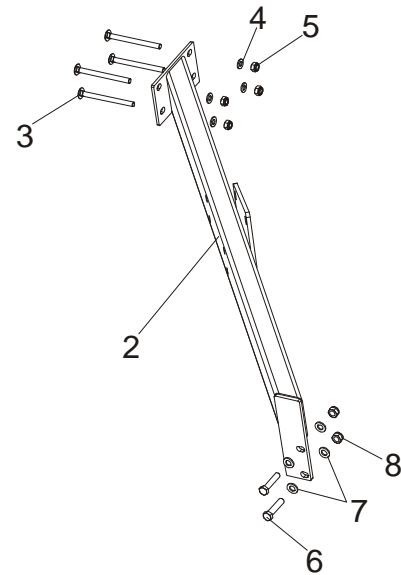

LES012a

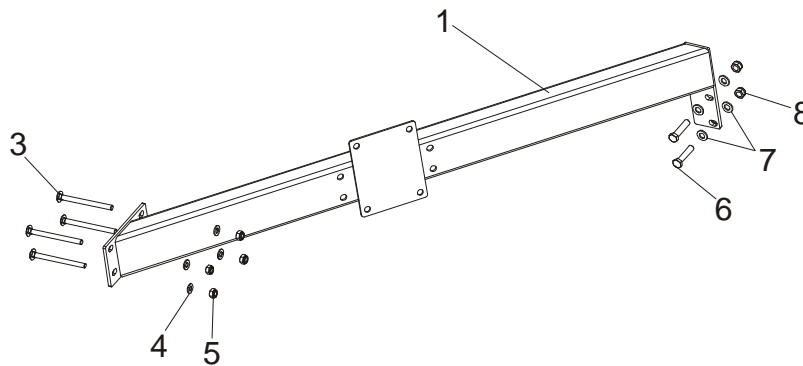

REF.	DESCRIPTION (◆ Indicates Parts Available In Assemblies Only)	PART #	QTY.
1	TUBE, LES BED FRONT	100551-1	1
2	TUBE, LES BED REAR	100545-1	1
3	BOLT, M10X125 CARRIAGE	F81003-34	8
4	WASHER, 10.5 ZINC FLAT	F81055-1	8
5	NUT, M10-8-B HEX NYLON ZINC LOCK	F81033-1	8
6	BOLT, M12X55-8.8 HEX HEAD ZINC	F81004-12	4
7	WASHER, 13 FLAT ZINC	F81056-1	8
8	NUT, M12-8 HEX NYLON ZINC LOCK	F81034-2	4

8.9 Bumpers

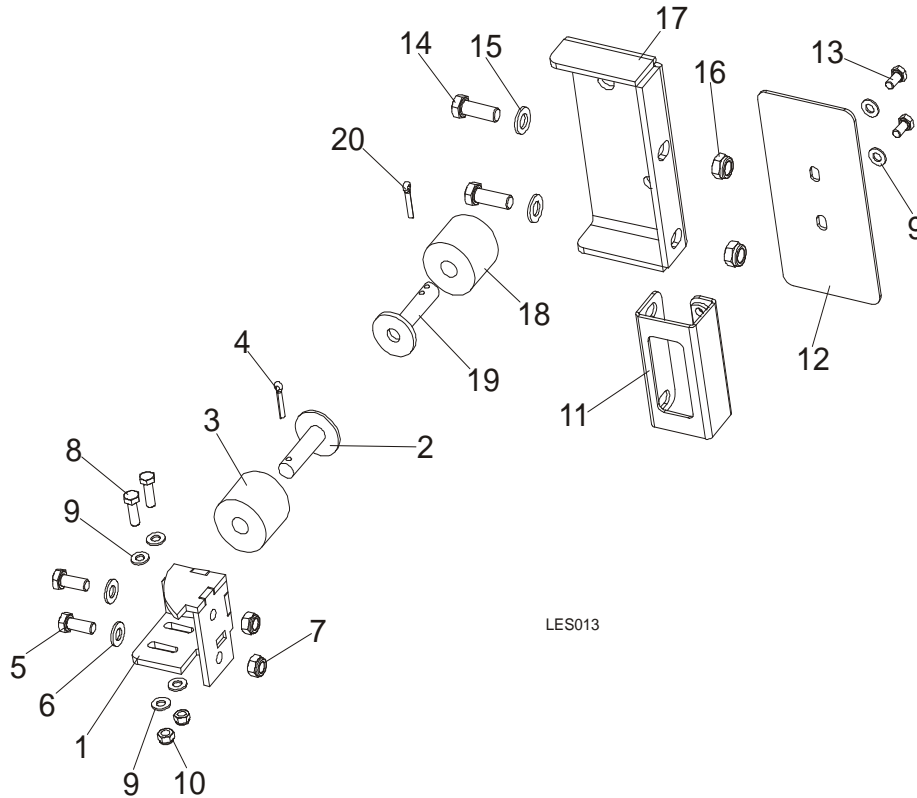

LES013

REF.	DESCRIPTION (◆ Indicates Parts Available In Assemblies Only)	PART #	QTY.
1	MOUNT WELDMENT, FRONT CARRIAGE STOP	089712-1	1
2	MOUNT WELDMENT, CARRIAGE STOP PTD	086182-1	1
3	BUSHING, 11/16x2 1/8x1 3/4 RUBBER	P12165	1
4	PIN, 3/16 X 1 COTTER	F05012-21	1
5	BOLT, M10X25-8.8 HEX HEAD FULL THREAD ZINC	F81003-11	2
6	WASHER, 10.5 ZINC FLAT	F81055-1	2
7	NUT, M10-8-B HEX NYLON ZINC LOCK	F81033-1	2
8	BOLT, M8x25-8.8-B HEX HEAD FULL THREAD ZINC	F81002-5	2
9	WASHER, 8.4 FLAT ZINC	F81054-1	2
10	NUT, M8-8-B HEX NYLON ZINC LOCK	F81032-2	2
11	BRACKET WELDMENT, REAR MAIN TUBE COVER	087105-1	1
12	COVER, MAIN TUBE REAR	015023	1
13	BOLT, M8x16-8.8-B HEX HEAD FULL THREAD ZINC	F81002-20	2
14	BOLT, M12 X 35-8.8-FE/ZN5 HEX HEAD FULL THREAD	F81004-24	2
15	WASHER, 13 FLAT ZINC	F81056-1	2
16	NUT, M12-8 HEX NYLON ZINC LOCK	F81034-2	2
	BUMPER, REAR COMPLETE	091828	1
17	BRACKET, BUMPER REAR	091829-1	1
18	BUSHING, 11/16X2 1/8X1 3/4 RUBBER	P12165	1
19	STOP, (PTD) CARRIAGE	W09293	1
20	PIN, 3/16 X 1 COTTER	F05012-21	1

8.10 Remote Equipment Option

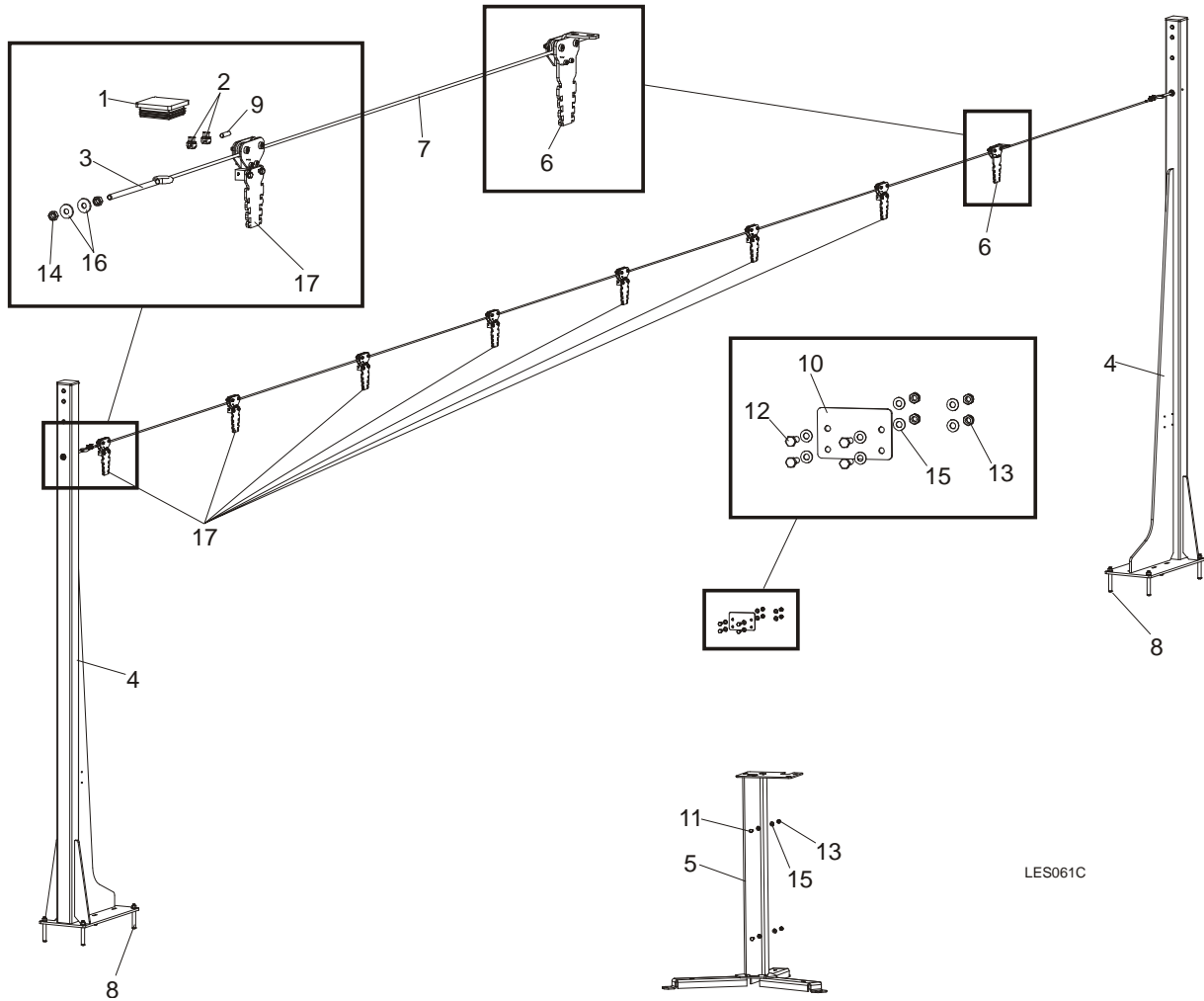

LES061C

REF.	DESCRIPTION (◆ Indicates Parts Available In Assemblies Only)	PART #	QTY.
	EQUIPMENT, LT20B REMOTE COMPLETE	501649	1
1	CAP, EDGER FRAME	089644	2
2	CLAMP, LT20 STRING	091614	4
3	TENSIONER, ZINC-PLATED	500846-1	2
4	COLUMN, LT20B LINE GUIDE	503600-1	2
5	STAND, LT20B CONTROL BOX	501651-1	1
6	PULLEY, STATIONARY	504264	1
7	CABLE, 6MM (11,5 M) STEEL	504279	1
8	PIN, LT 16X120	501877	8
9	POINTER, 6MM STEEL CABLE	504280-1	2
10	CAP, LT20B REMOTE CONTROL BOX	501879-1	1
11	BOLT, M8X20-5.8 HEX HEAD FULL THREAD ZINC	F81002-1	2
12	BOLT, M8x25-8.8-B HEX HEAD FULL THREAD ZINC	F81002-5	4

13	NUT, M8-8-B HEX NYLON ZINC LOCK	F81032-2	6	
14	NUT, M10-8-B HEX ZINC	F81033-3	4	
15	WASHER, 8.4 FLAT ZINC	F81054-1	12	
16	WASHER, 10.5 ZINC FLAT SPECIAL	F81055-6	4	
17	PULLEY	504114	7	

8.11 Bed Frame Decals

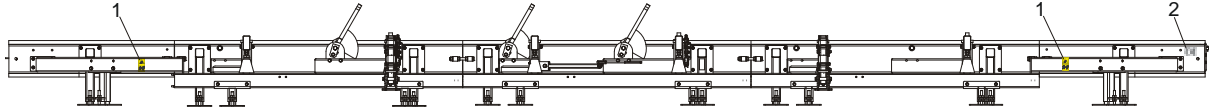

LES014

REF.	DESCRIPTION (◆ Indicates Parts Available In Assemblies Only)	PART #	QTY.	
	PICTOGRAPHIC DECAL KIT, LES	101215	1	
	PICTOGRAPHIC DECAL KIT, LT20AC See Section 4.5	099509	1	
1	DECAL, KEEP AWAY DANGER, PICTOGRAM	099221	2	
2	DECAL, CE CERTIFIED SAWMILL (SMALL)	P85070	1	

8.12 Saw Head Transportation Holder, LT70B

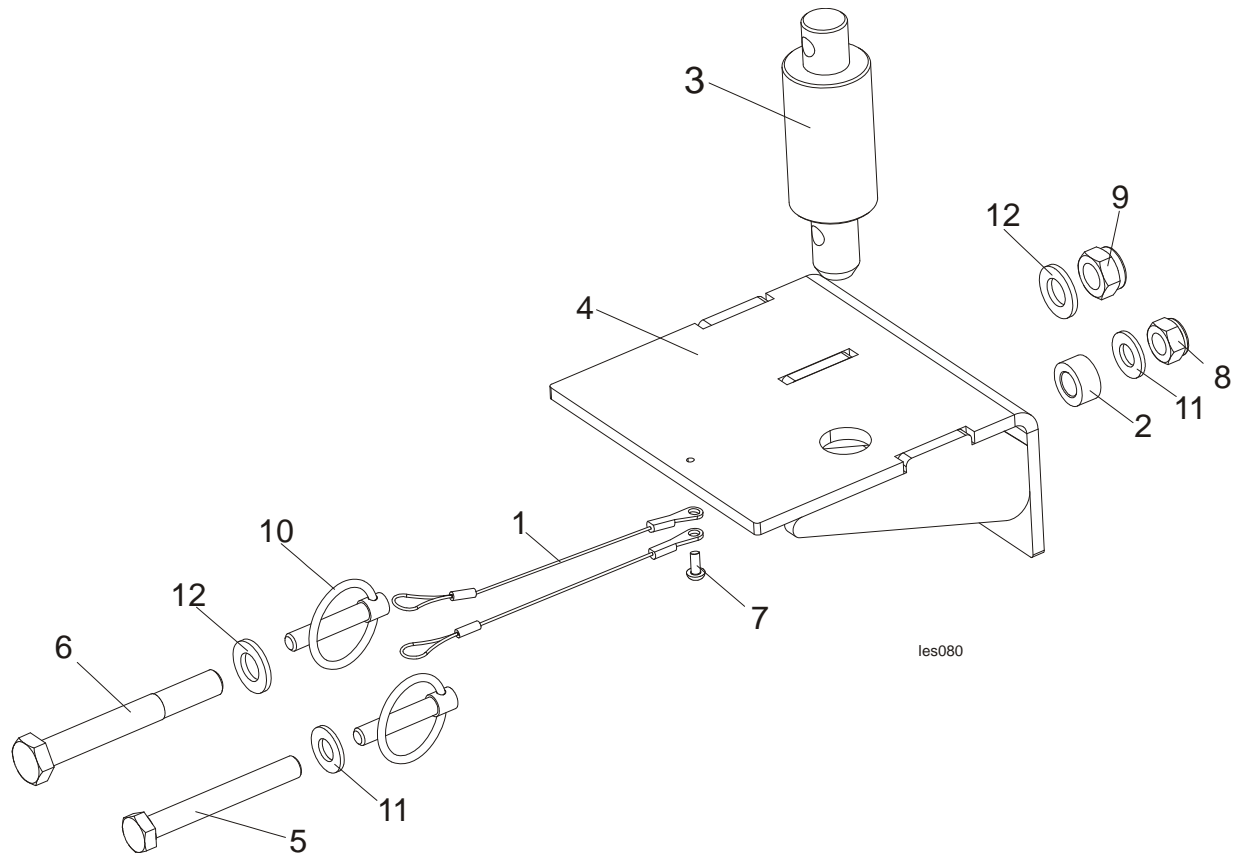

REF	DESCRIPTION (◆ Indicates Parts Available In Assemblies Only)	PART #	QTY.
	HOLDER, SAW HEAD TRANSPORTATION LT70B-COMPLETE	509277	1
1	LANYARD, 3/64x6	016030	2
2	BUSHING, SPACER ZINC-PLATED	090936-1	1
3	PIN, SAW HEAD REST LT20 PTD.	097935-1	1
4	HOLDER, TRANSPORTATION LT70B WLDMT/PTD	509278-1	1
5	BOLT, HEX HEAD M10x80-8.8-ZINC	F81003-50	1
6	BOLT, M12X95 8.8 HEX HEAD ZINC	F81004-29	1
7	SCREW, M4X12-5.8-B-CROSS RECESSED PAN HEAD ZINC	F81011-43	1
8	NUT, M10 HEX NYLON ZINC LOCK	F81033-1	1
9	NUT, M12 8 HEX NYLON ZINC LOCK	F81034-2	1
10	PIN, 8 BN914 (Bossard 1364650) LOCK	F81046-2	2
11	WASHER, 10,5 FLAT ZINC	F81055-1	2
12	WASHER, 13MM FLAT ZINC	F81056-1	2

SECTION 9 LOG CLAMP, LOADING RAMP & TOE BOARD

9.1 Log Clamp, LES

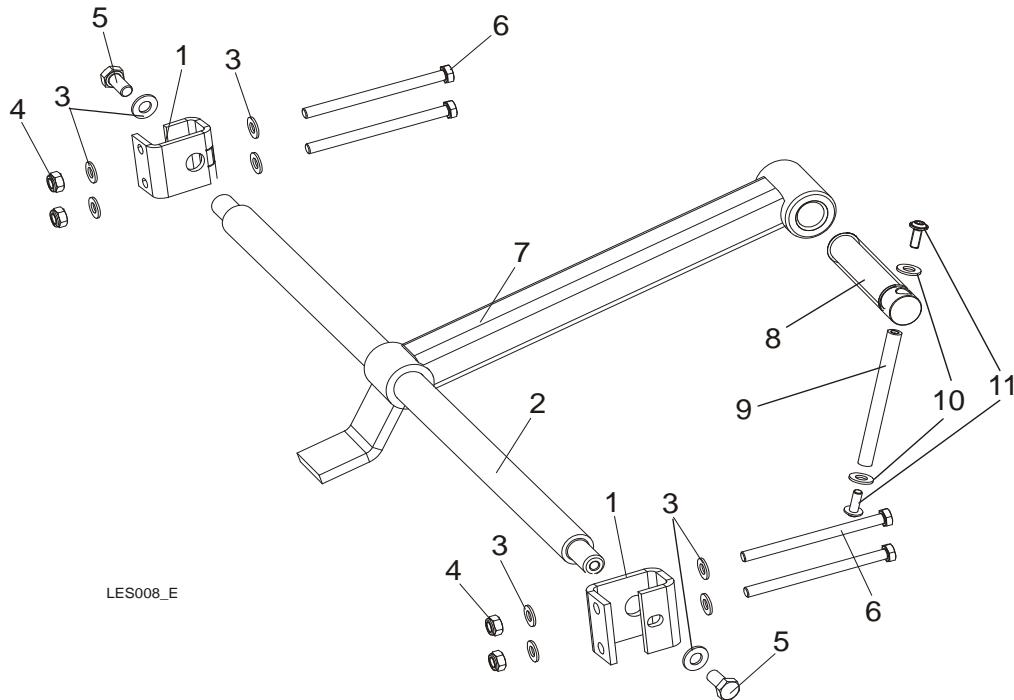

REF.	DESCRIPTION (◆ Indicates Parts Available In Assemblies Only)	PART #	QTY.
	CLAMP-LES	510230	1
1	BRACKET, LOG CLAMP MOUNT ZINC-PL.	500338-1	2
2	ROD, MAIN CLAMP	100643	1
3	WASHER, 10.5 FLAT ZINC	F81055-1	10
4	NUT, M10-8-B HEX NYLON ZINC LOCK	F81033-1	4
5	BOLT, M10X20-5.8 HEX HEAD FULL THREAD ZINC	F81003-1	2
6	BOLT, M10 X 80-8.8 HEX HEAD ZINC	F81003-50	4
7	CLAMP ARM	508453-1	1
	CLAMP BOLT - COMPLETE	507563	1
8	CLAMP BOLT	507463	1
	ROD - COMPLETE	511924	1
9	ROD - ZINC-PLATED	511923-1	1
10	WASHER, 8.4 FLAT ZINC	F81054-1	2
11	BOLT, M6x16 BN 11252 "BOSSARD"	F81001-24	2

9.2 Loading Ramp

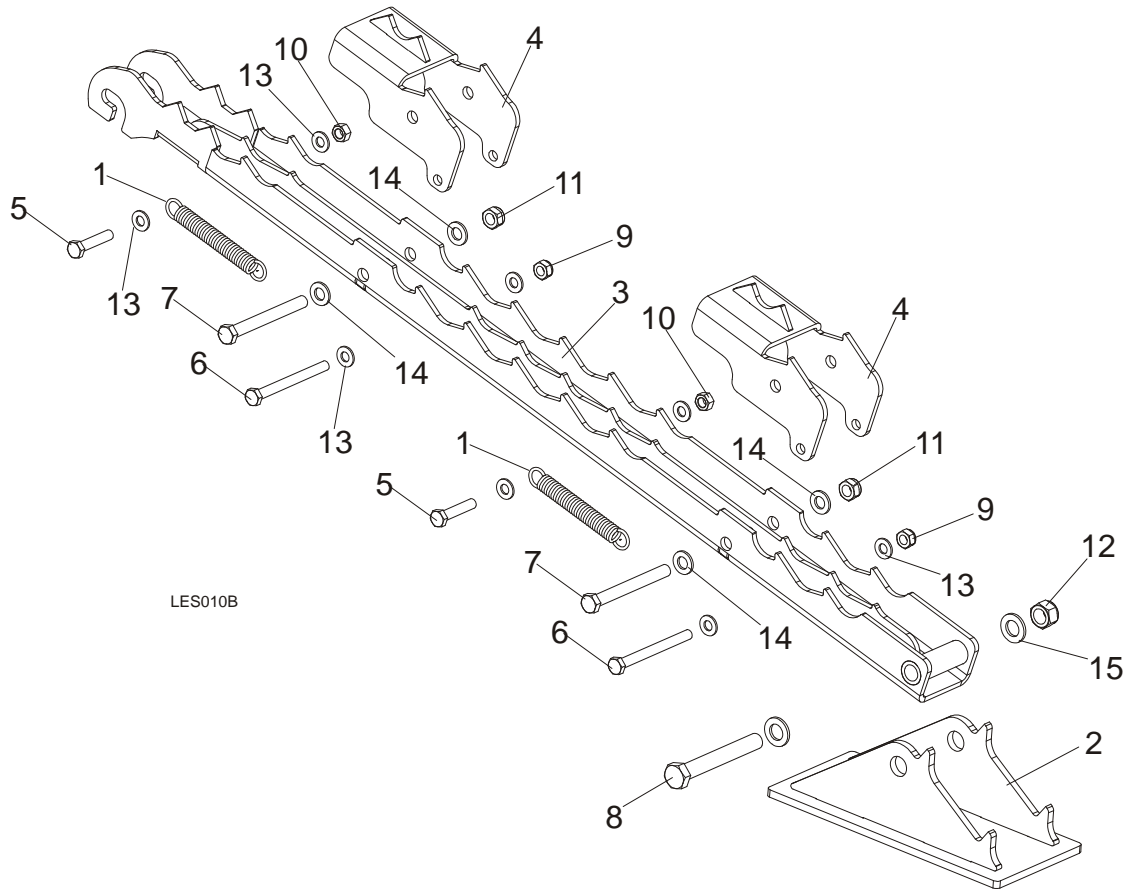

LES010B

REF.	DESCRIPTION (◆ Indicates Parts Available In Assemblies Only)	PART #	QTY.
	LOADING RAMP, LES	500795	1
1	Spring, $\phi 1.9 \times \phi 14.2 \times 104$	091865	2
2	Foot, LES Loading Ramp	500788-1	1
3	Loading Ramp, LES	500790-1	1
4	Plate, LES Log w/Teeth	500799-1	2
5	Bolt, M10X50-8.8 Hex Head Full Thread Zinc	F81003-4	2
6	Bolt, M10x110 8.8 Hex Head Zinc	F81003-43	2
7	Bolt, M12X115-8.8 Hex Head Zinc	F81004-33	2
8	Bolt, ISO 24014 M16 X 120 8.8 A2E	F81006-25	1
9	Nut, M10-8-B Hex Nylon Zinc Lock	F81033-1	2
10	Nut, M10-8-B Hex Zinc	F81033-3	2
11	Nut, M12-8 Hex Nylon Zinc Lock	F81034-2	2
12	Nut, M16-8 Hex Nylon Zinc Lock	F81036-2	1
13	Washer, 10.5 Zinc Flat	F81055-1	8
14	Washer, 13 Flat Zinc	F81056-1	4
15	Washer, 17 Flat Zinc	F81058-1	2

9.3 Manual Toe Board

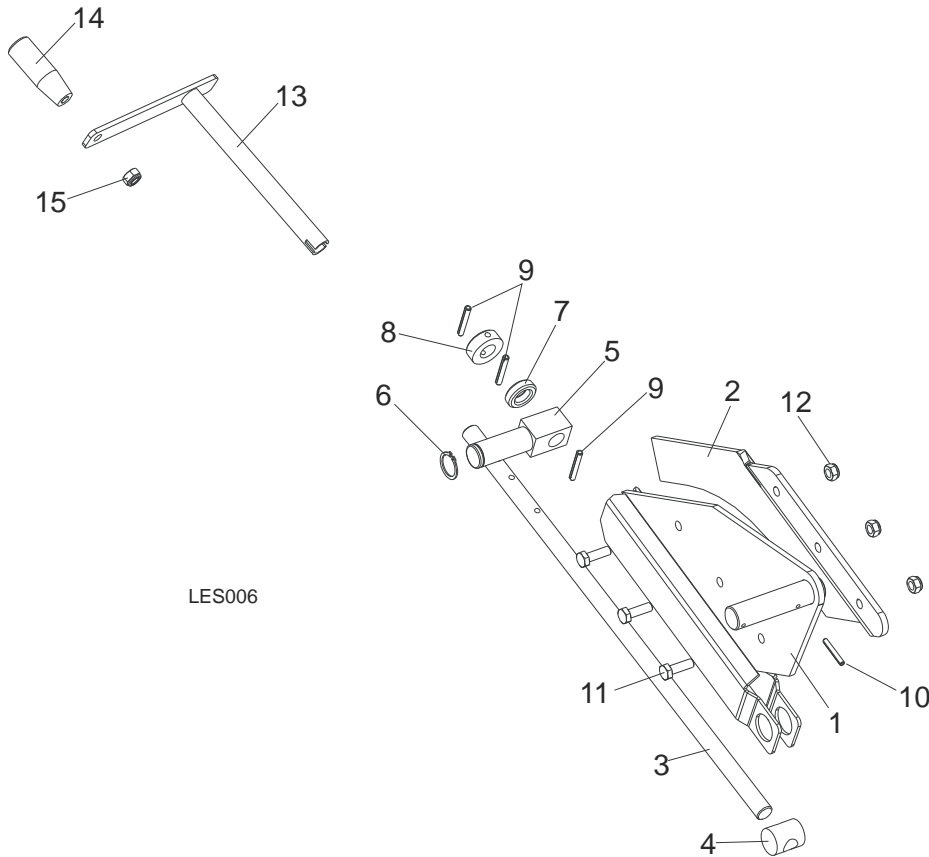

REF.	DESCRIPTION (◆ Indicates Parts Available In Assemblies Only)	PART #	QTY.
	TOE BOARD KIT, MANUAL REAR	094928	2
1	Plate Weldment, Manual Toe Board Rear	094926-1	1
2	Extension, Manual Toe Board Plate (II)	095202-1	1
3	Shaft, Manual Toe Board	090344-1	2
4	Nut, Special Threaded	090017	2
5	Pivot, Manual Toe Board Shaft (I)	094931-1	2
6	Ring, Z 22 Outside Retaining	F81090-24	2
7	Bearing, 5/8" Thrust	P04214	2
8	Collar, 16	F81039-6	2
9	Pin, 5x35-N-C PN-EN ISO 8752 Roll	F81044-9	6
10	Pin, 4x30 Zinc Roll	F81044-7	2
11	Bolt, M8 x 25-8.8-B Hex Head Full Thread Zinc	F81002-5	6
12	Nut, M8-8-B Hex Nylon Zinc Lock	F81032-2	6
	CRANK ASSEMBLY, MANUAL TOE BOARD	500600	1
13	Crank, Manual Toe Board	500599-1	1
14	Knob, Plastic Crank Handle	086338	1
15	Nut, M10-8-B Nylon Hex Zinc Lock	F81033-1	1

9.4 H1/H2/H3 Control Assemblies - Options

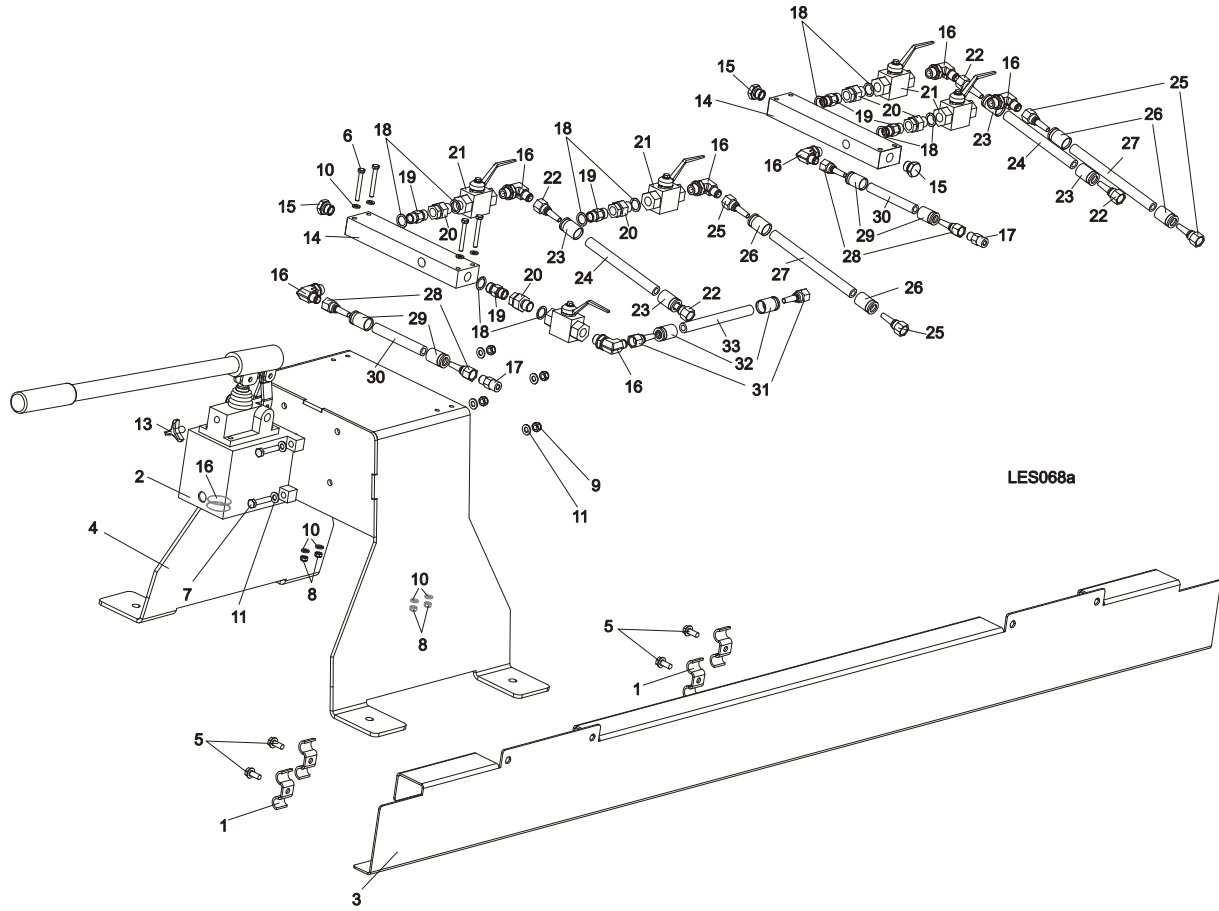

REF.	DESCRIPTION (◆ Indicates Parts Available In Assemblies Only)	PART #	QTY.
	H1 CONTROL ASSEMBLY-LES	504360	1
1	CLAMP, 3/8" HOSE	016041	8
2	PUMP, PMS12/TNK1 HAND W/RELIEF VALVE	505630	1
3	CHANNEL, HYDRAULIC HOSE GUIDE	502419-1	3
4	BRACKET, PUMP & VALVE MOUNT	502543-1	1
5	SCREW, 5/16-18 x 3/4 SELF-TAPPING	F05015-30	8
6	BOLT, M6x50-8.8 HEX HEAD ZINC	F81001-62	4
7	BOLT, M8x40-8.8 HEX HEAD FULL THREAD ZINC	F81002-15	4
8	NUT, M6-8-B HEX NYLON ZINC LOCK	F81031-2	4
9	NUT, M8-8-B HEX NYLON ZINC LOCK	F81032-2	4
10	WASHER, 6.4 FLAT ZINC	F81053-1	8
11	WASHER, 8.4 FLAT ZINC	F81054-1	8
12	MAGNET, MW.38x12/N38 NEODYMIUM	500022	1
13	VALVE, LES HAND PUMP RELIEF - COMPLETE	083712	1
14	BLOCK, 4-WAY HYDRAULIC VALVE	502540-1	1
15	CAP, 3/8 BSPP (G3/8)	502544	2
	VALVE, H1 LES HYDRAULIC	504361	1

16	FITTING, 3/8" BSP-9/16" JIC ELBOW	096335	3	
17	FITTING, G3/8-9/16-18JIC HAND PUMP	091842	1	
18	WASHING, 16x22 SEALING COPPER	502420	4	
19	FITTING, 3/8 BSP GZ STRAIGHT	503617	2	
20	FITTING, 3/8" BSP-GZ/GW 600 106 06 REDUCER	503616	2	
21	VALVE, 3/8 " G BALL	502056	2	
	PHD 2T3/8X4.200 W9/16UNF-W9/16UNF	502413	1	
22	FITTING, JIC 9/16-18	085900	2	
23	CRIMP SOCKET, 3/8" HYDRAULIC HOSE	085901	2	
24	HOSE, 3/8" (C/S-20MPa)P/N8106-6-06 HYDRAULIC	R02132	(4.2m)	
	PHD 2T3/8X4.200 W9/16UNF-W9/16UNF	502414	1	
25	FITTING, JIC 9/16-18	085900	2	
26	CRIMP SOCKET, 3/8" HYDRAULIC HOSE	085901	2	
27	HOSE, 3/8" (C/S-20MPa)P/N8106-6-06 HYDRAULIC	R02132	(7.2m)	
	PHD 2T3/8X4.200 W9/16UNF-W9/16UNF	502416	1	
28	FITTING, JIC 9/16-18	085900	2	
29	CRIMP SOCKET, 3/8" HYDRAULIC HOSE	085901	2	
30	HOSE, 3/8" (C/S-20MPa)P/N8106-6-06 HYDRAULIC	R02132	(0.58m)	
	H2/H3-LES CONTROL ASSEMBLY	502055	1	
1	CLAMP, 3/8" HOSE	016041	8	
2	PUMP, PMS12/TNK1 HAND W/RELIEF VALVE	505630	1	
3	CHANNEL, HYDRAULIC HOSE GUIDE	502419-1	3	
4	BRACKET, PUMP & VALVE MOUNT	502543-1	1	
5	SCREW, 5/16-18 x 3/4 SELF-TAPPING	F05015-30	8	
6	BOLT, M6x50-8.8 HEX HEAD ZINC	F81001-62	4	
7	BOLT, M8x40-8.8 HEX HEAD FULL THREAD ZINC	F81002-15	4	
8	NUT, M6-8-B HEX NYLON ZINC LOCK	F81031-2	4	
9	NUT, M8-8-B HEX NYLON ZINC LOCK	F81032-2	4	
10	WASHER, 6.4 FLAT ZINC	F81053-1	8	
11	WASHER, 8.4 FLAT ZINC	F81054-1	8	
12	MAGNET, MW.38x12/N38 NEODYMIUM	500022	1	
13	VALVE, LES HAND PUMP RELIEF - COMPLETE	083712	1	
14	BLOCK, 4-WAY HYDRAULIC VALVE	502540-1	1	
15	CAP, 3/8 BSPP (G3/8)	502544	1	
	VALVE, H2/3-LES HYDRAULIC	502040	1	
16	FITTING, 3/8" BSP-9/16" JIC ELBOW	096335	4	
17	FITTING, G3/8-9/16-18JIC HAND PUMP	091842	1	
18	WASHER, 16x22 SEALING COPPER	502420	6	
19	FITTING, 3/8 BSP GZ STRAIGHT	503617	3	
20	FITTING, 3/8" BSP-GZ/GW 600 106 06 REDUCER	503616	3	
21	VALVE, 3/8 " G BALL	502056	3	
	PHD 2T3/8X4.200 W9/16UNF-W9/16UNF	502413	1	
22	FITTING, JIC 9/16-18	085900	2	
23	CRIMP SOCKET, 3/8" HYDRAULIC HOSE	085901	2	
24	HOSE, 3/8" (C/S-20MPa)P/N8106-6-06 HYDRAULIC	R02132	(4.2m)	
	HOSE, 2T3/8X4.200 W9/16UNF-W9/16UNF HYDRAULIC	502414	1	

25	FITTING, JIC 9/16-18	085900	2	
26	CRIMP SOCKET, 3/8" HYDRAULIC HOSE	085901	2	
27	HOSE, 3/8" (C/S-20MPa)P/N8106-6-06 HYDRAULIC	R02132	(7.2m)	
	PHD 2T3/8X4.200 W9/16UNF-W9/16UNF	502416	1	
28	FITTING, JIC 9/16-18	085900	2	
29	CRIMP SOCKET, 3/8" HYDRAULIC HOSE	085901	2	
30	HOSE, 3/8" (C/S-20MPa)P/N8106-6-06 HYDRAULIC	R02132	(0.58m)	
	PHD 2T3/8X4.200 W9/16UNF-W9/16UNF	092357	1	
31	FITTING, JIC 9/16-18	085900	2	
32	CRIMP SOCKET, 3/8" HYDRAULIC HOSE	085901	2	
33	HOSE, 3/8" (C/S-20MPa)P/N8106-6-06 HYDRAULIC	R02132	(6.25m)	

9.5 Toe Board Roller Option

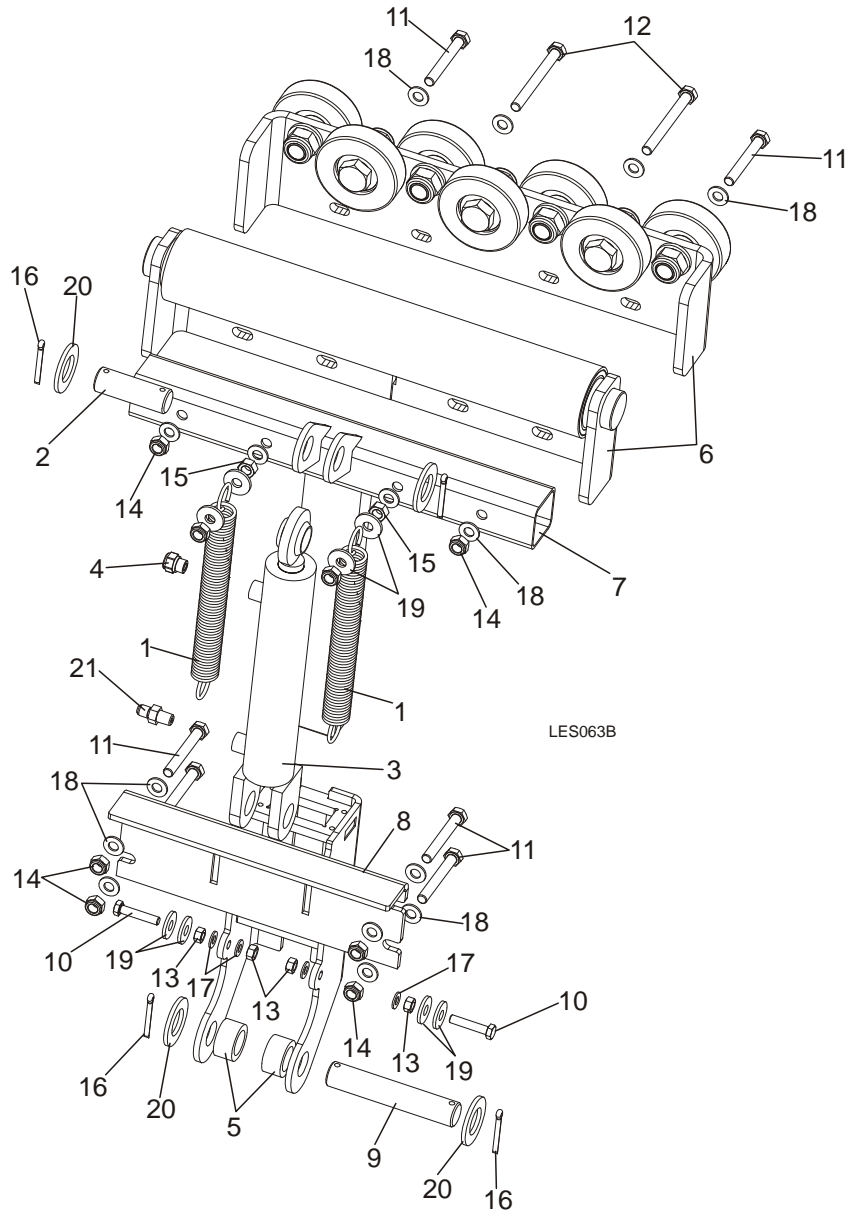

REF.	DESCRIPTION (◆ Indicates Parts Available In Assemblies Only)	PART #	QTY.
	KIT, ROLLER TOE BOARD	502110	1
1	SPRING, 1 1/16x8x.135 DIA	015718	2
2	PIN, 25X75 ZINC-PLATED	088659-1	1
3	CYLINDER, CJ-S170-16-40/25/152 HYDRAULIC	088681	1
4	AIR VENT VALVE 2901-14-17	090794	1
5	BUSHING, 38/25.4-19.6	505514-1	2
6	BRACKET, HYDRAULIC TOE BOARD - FRONT	502050-1	1
	RETROFIT KIT, ROLLER TURNER OPTION	504893-S	1

7	LINE FEED PART, TOE BOARD	502104-1	1	
8	GUIDE, TOE BOARD ROLLER	502105-1	1	
9	PIN, 25 x 140	502109-1	1	
10	BOLT, M8 X 45 - 8.8 HEX HEAD FULL THREAD ZINC	F81002-14	2	
11	BOLT, M10x75-8.8 HEX HEAD ZINC	F81003-15	6	
12	BOLT, M10x100-8.8 HEX HEAD FULL THREAD ZINC	F81003-91	2	
13	NUT, M8-8-B HEX ZINC	F81032-1	6	
14	NUT, M10-8-B HEX NYLON ZINC LOCK	F81033-1	8	
15	NUT, M10-8-B HEX ZINC	F81033-3	2	
16	PIN, 5 X 40 COTTER	F81043-31	4	
17	WASHER, 8.4 FLAT ZINC	F81054-1	4	
18	WASHER, 10.5 FLAT ZINC	F81055-1	16	
19	WASHER, 10.5 ZINC FLAT SPECIAL	F81055-6	8	
20	WASHER, 28 FLAT ZINC	F81061-1	4	
21	FITTING, 3/8JIC-1/4NPT STRAIGHT	015560	1	

9.6 Roller Turner Option

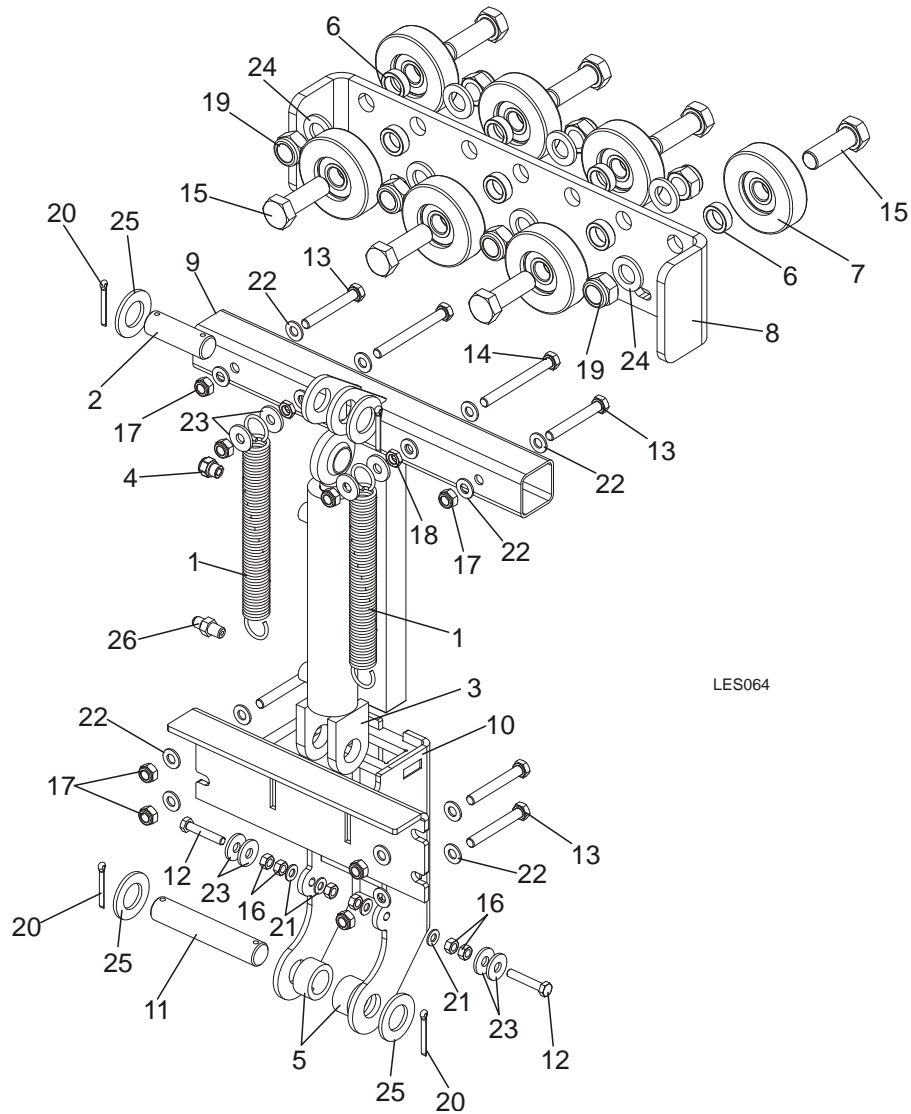

REF	DESCRIPTION (◆ Indicates Parts Available In Assemblies Only)	PART #	QTY.
	KIT, ROLLER TURNER	502309	1
1	SPRING, 1 1/16x8x.135 DIA	015718	2
2	PIN, 25X75 ZINC-PLATED	088659-1	1
3	CYLINDER, CJ-S170-16-40/25/152 HYDRAULIC	088681	1
4	AIR VENT VALVE 2901-14-17	090794	1
5	BUSHING, 38/25.4-19.6	505514-1	2
6	BUSHING, 21X30X10 SPACER ZINC	099351-1	7
7	ROLLER, RP-90, 6304 POLYURETHANE	099689	7
8	PLATE, TOE BOARD ROLLER MAIN	502037-1	1
9	LINE FEED PART, TOE BOARD	502104-1	1
10	GUIDE, TOE BOARD ROLLER	502105-1	1

11	PIN, 25 x 140	502109-1	1	
12	BOLT, M8x45-8.8 HEX HEAD FULL THREAD ZINC	F81002-14	2	
13	BOLT, M10X75-8.8 HEX HEAD ZINC	F81003-15	6	
14	BOLT, M10x100-8.8 HEX HEAD FULL THREAD ZINC	F81003-91	2	
15	BOLT, M20X60-8.8 HEX HEAD ZINC	F81007-7	7	
16	NUT, M8-8-B HEX ZINC	F81032-1	4	
17	NUT, M10-8-B HEX NYLON ZINC LOCK	F81033-1	8	
18	NUT, M10-8-B HEX ZINC	F81033-3	2	
19	NUT, M20-6 HEX	F81037-2	7	
20	PIN, 5 X 40 COTTER	F81043-31	4	
21	WASHER, 8.4 FLAT ZINC	F81054-1	4	
22	WASHER, 10.5 FLAT ZINC	F81055-1	16	
23	WASHER, 10.5 SPECIAL FLAT ZINC	F81055-6	8	
24	WASHER, 21 FLAT ZINC	F81059-2	7	
25	WASHER, 28 FLAT ZINC	F81061-1	4	
26	FITTING, 3/8JIC-1/4NPT STRAIGHT	015560	1	

9.7 Winch Option

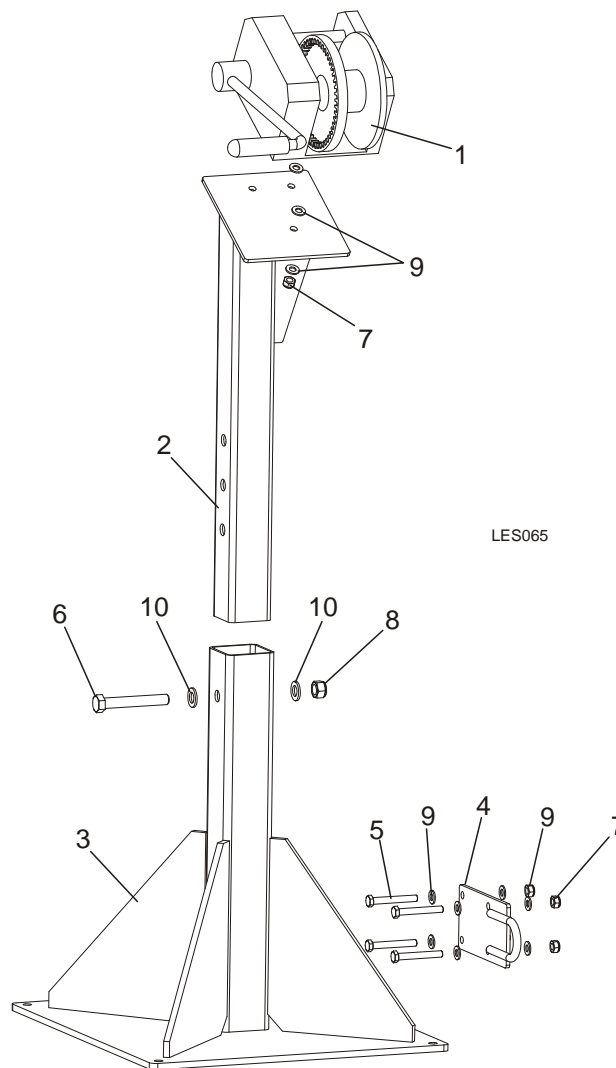

REF	DESCRIPTION (◆ Indicates Parts Available In Assemblies Only)	PART #	QTY.
	WINCH ASSEMBLY, LES	501341	1
1	WINCH, AL-KO TYPE 901	096453	1
2	TUBE, VERTICAL OUTRIGGER	501128-1	1
3	BASE WDMT, WINCH	502068-1	1
4	BRACKET, CABLE	502418-1	1
5	BOLT, M10x75-8.8 HEX HEAD ZINC	F81003-15	4
6	BOLT, M16x110-8.8 HEX HEAD ZINC	F81006-24	1
7	NUT, M10-8-B HEX NYLON ZINC LOCK	F81033-1	7
8	NUT, M16 HEX NYLON ZINC LOCK	F81036-2	1
9	WASHER, 10.5 FLAT ZINC	F81055-1	14
10	WASHER, 17 FLAT ZINC	F81058-1	2

9.8 Log Side Supports w/Lever Option

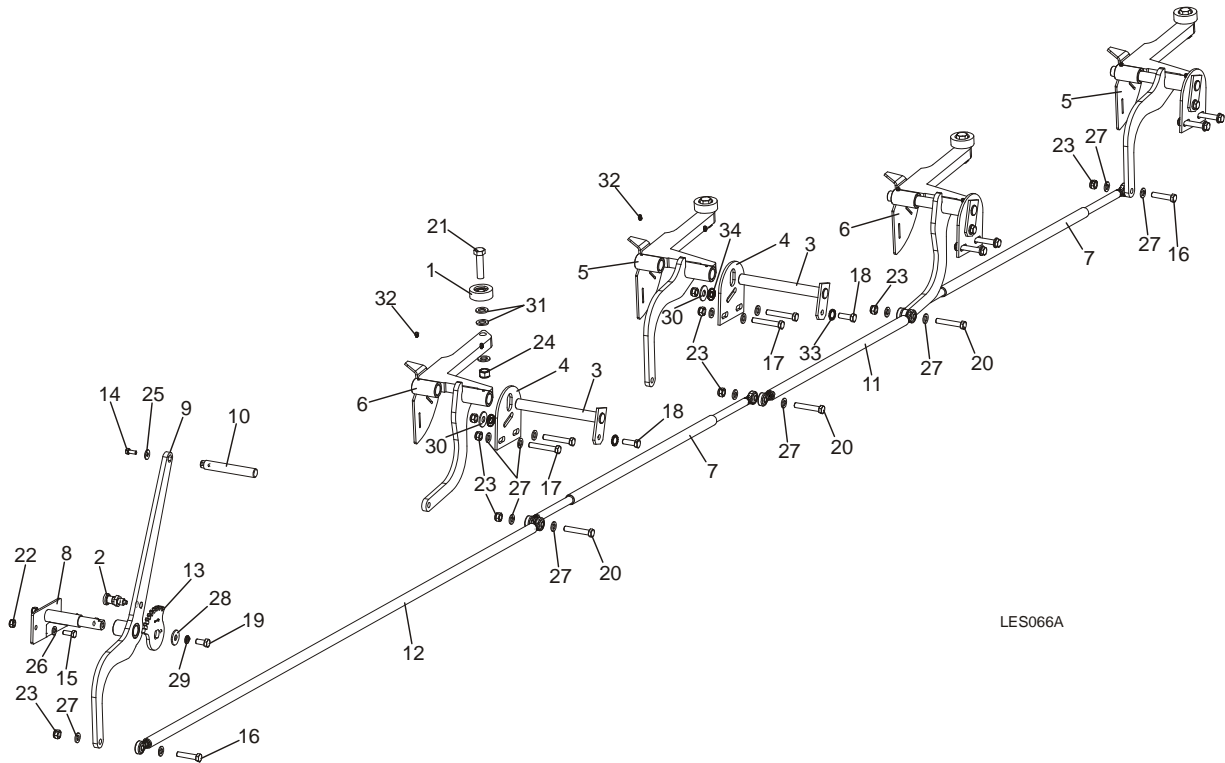

REF	DESCRIPTION (◆ Indicates Parts Available In Assemblies Only)	PART #	QTY.
	SUPPORT KIT, LOG SIDE W/LEVER	503672	1
1	ROLLER ASSY, SIDE SUPPORT	015014	4
2	PIN, DETENT	090197	1
3	PIN, SIDE SUPPORT ZINC-PLATED	091549-1	4
4	PLATE, LOG SIDE SUPPORT MOUNT PTD	091591-1	4
5	SIDE SUPPORT, W/COVER 1	502955-1	2
6	SIDE SUPPORT, W/COVER 2	502958-1	2
7	STRING, EXTREME COMPLETE	502961	2
8	SHAFT WELDMENT, COMPLETE	502966-1	1
9	LEVER	502977-1	1
10	KNOB, LEVER	502979	1
11	STRING, MIDDLE COMPLETE	502980	1
12	STRING, LEVER COMPLETE	502981	1
13	BLOCK, SIDE SUPPORT LEVER	502982-1	1
14	BOLT, M8X20-5.8 HEX HEAD FULL THREAD ZINC	F81002-1	1
15	BOLT, M10X25-8.8 HEX HEAD FULL THREAD ZINC	F81003-11	2
16	BOLT, M12X55-8.8 HEX HEAD ZINC	F81004-12	2
17	BOLT, M12 X 75-8.8 ZINC	F81004-21	8
18	BOLT, M12 X 35-8.8-FE/ZN5 HEX HEAD FULL	F81004-24	4
19	BOLT, M12X25-8.8 HEX HEAD FULL THREAD ZINC	F81004-31	1
20	BOLT, M12x70 8.8 HEX HEAD ZINC	F81004-39	3

21	BOLT, M16x65-8.8 HEX HEAD FULL THREAD ZINC	F81006-1	4	
22	NUT, M10-8-B HEX NYLON ZINC LOCK	F81033-1	2	
23	NUT, M12-8 HEX NYLON ZINC LOCK	F81034-2	17	
24	NUT, M16,HEX, NYLON ZINC LOCK	F81036-2	4	
25	WASHER, 8.5 FLAT, ZINC SPECIAL	F81054-11	1	
26	WASHER, 10.5 FLAT ZINC	F81055-1	2	
27	WASHER, 13 FLAT ZINC	F81056-1	26	
28	WASHER, 13 SPECIAL FLAT ZINC	F81056-14	1	
29	WASHER, Z12.2 SPLIT LOCK ZINC	F81056-2	1	
30	WASHER, 15 SPECIAL FLAT ZINC	F81057-3	1	
31	WASHER, 17 FLAT ZINC	F81058-1	12	
32	FITTING, 3/16X3/16 STRAIGHT GREASE	P04107	9	
33	WASHER, SPECIAL BOSART/2S, BN781 M12/13	F81056-16	4	
34	WASHER, SPECIAL BOSART/2S M12/12,3/30,3	F81056-17	4	