



user manual

Instrukcja obsługi | Руководство пользователя
Manuel de l'Utilisateur | Betriebsanweisung
Bruksanvisning | Manual del Usuario
Betjeningsvejledning | Gebruikershandleiding
Käyttöohjeet | Manual de utilizare | Bruksanvisning
Manuale d'uso | Příručka uživatele | Navodila
za uporabo

Retain for future use
Zachować do przyszłego użytku
Сохраните для последующего
использования
A conserver pour une utilisation future
Für zukünftige Benutzung aufbewahren
Behold for senere bruk
Säilytä nämä käyttöohjeet tulevaa tarvetta marten
Opbevar manualen til fremtidig brug
Bewaren voor gebruik in de toekomst
Conservare il presente manuale a l'uso futuro
Păstrați acest manual pentru utilizare viitoare
Conservar para futuras consultas
Behall för framtida användning
Uchovejte pro další použití
Hranite za prihodnje uporabo

Wood-Mizer®

Safety, Setup, Operation & Maintenance Manual

LT20 B1-4 E15 SMH	rev. A5.01
LT20 B1-4 D22 SMH	rev. A5.01
LT20 B1-4 G25 SMH	rev. A5.01



Safety is our #1 concern! Read and understand all safety information and instructions before operating, setting up or maintaining this machine.

September 2008

Form #631

**This is the original language
for the manual.**

*General Contact Information
Branches & Authorized Sales Centers*

SECTION 1	SAFETY & GENERAL INFORMATION	1-1
1.1	Blade Handling.....	1-2
1.2	Sawmill Setup.....	1-3
1.3	Sawmill Operation.....	1-4
1.4	Sawmill Maintenance	1-6
1.5	Belt Sizes	1-12
1.6	Blade Sizes	1-12
1.7	Cutting Capacity	1-12
1.8	Engine/Motor Specifications	1-13
1.9	Noise Level.....	1-14
1.10	Overall Dimensions	1-14
1.11	Overall Dimensions (Packed).....	1-15
1.12	Chains	1-15
1.13	Sawdust Extractor Specifications	1-15
1.14	Components	1-16
SECTION 2	SAWMILL ASSEMBLY	2-1
2.1	Mounting Parts of LT20 Sawmills with Electric Motors	2-1
	<i>Parts specifications</i>	
	<i>Specifications of Fasteners</i>	
	<i>Tools Necessary for Assembling the Sawmill</i>	
2.2	Unpacking the Sawmill	2-6
	<i>Standard version of the Sawmill.</i>	
	<i>Sawmill with Remote Equipment.</i>	
2.3	Bed Frame Assembly	2-9
SECTION 3	SETUP & OPERATION	3-1
3.1	Sawmill Setup.....	3-1
	<i>Setting up sawmills equipped with non-adjustable legs</i>	
	<i>Setting up sawmills equipped with outrigger legs</i>	
	<i>Sawmills with cable guide</i>	
3.2	Middle Track Cover	3-11
3.3	Replacing The Blade	3-12
3.4	Tensioning The Blade.....	3-13
3.5	Tracking The Blade	3-14
3.6	Starting The Motor (AC sawmill)	3-16

Table of Contents

Section-Page

3.7	Loading, Turning, And Clamping Logs	3-18	
	<i>Sawmills equipped with MH (Manual Hydraulics)</i>		
	<i>Sawmills equipped with H1, H2 or H3 hydraulics</i>		
3.8	Up/Down Operation	3-25	
3.9	Blade Guide Arm Operation.....	3-26	
3.10	Power Feed Operation	3-27	
3.11	Cutting The Log	3-29	
3.12	Edging.....	3-30	
3.13	Blade Height Scale	3-31	
3.14	Water Lube Operation	3-33	
SECTION 4 MAINTENANCE			4-1
4.1	Wear Life.....	4-2	
4.2	Blade Guides	4-3	
4.3	Sawdust Removal	4-4	
4.4	Carriage Track, Wiper & Scrapers	4-5	
4.5	Vertical Mast Rails	4-6	
4.6	Miscellaneous	4-7	
4.7	Blade Tensioner.....	4-8	
4.8	Blade Wheel Belts	4-9	
4.9	Brake Pads Adjustment (Gas / Diesel Sawmills Only)	4-10	
4.10	Drive Belt Adjustment	4-11	
4.11	Up/Down System.....	4-14	
4.12	Power Feed System	4-16	
4.13	Power Feed System (CE Version Only).....	4-20	
SECTION 5 TROUBLESHOOTING GUIDE			5-1
5.1	Sawing Problems	5-1	
5.2	Electrical Problems.....	5-3	
5.3	Power Feed Problems	5-4	
5.4	Engine/Motor and Drive Pulleys Alignment.....	5-6	
SECTION 6 SAWMILL ALIGNMENT			6-1
6.1	Pre-Alignment Procedures.....	6-1	
6.2	Frame Setup.....	6-2	
6.3	Blade Installation And Alignment.....	6-2	
6.4	Blade Wheel Alignment	6-5	
6.5	Adjusting The Lower Track Rollers.....	6-10	
6.6	Adjusting Bed Rails To The Blade.....	6-13	
6.7	Blade Guide Arm Vertical Adjustment	6-14	
6.8	Blade Guide Arm Feed Chain Adjustment.....	6-15	
6.9	Saw Head Backlash Removal.....	6-17	
6.10	Blade Guide Arm Horizontal Adjustment.....	6-19	

Table of Contents

Section-Page

6.11	Aligning the Blade Guides	6-21
6.12	Blade Deflection	6-22
6.13	Blade Guide Vertical Tilt Adjustment.....	6-23
6.14	Blade Guide Spacing	6-25
6.15	Horizontal Tilt Adjustment.....	6-26
6.16	Horizontal Adjustment of Side Supports	6-27
6.17	Vertical Adjustment of Side Supports	6-28
6.18	Saw Head Tilt.....	6-29
6.19	Blade Height Scale Adjustment.....	6-31

1

Introduction

General Contact Information

Getting Service

Wood-Mizer is committed to providing you with the latest technology, best quality and strongest customer service available on the market today. We continually evaluate our customers' needs to ensure we're meeting current wood-processing demands. Your comments and suggestions are welcome.

General Contact Information

From Europe call your local distributor or our European Headquarters and Manufacturing Facility in Koło, Nagórna 114 St, Poland at **+48-63-2626000**. From the continental U.S., call our U.S. Headquarter 8180 West 10th St. Indianapolis, IN 46214, toll-free at **1-800-525-8100**. Ask to speak with a Customer Service Representative. Please have your machine identification number and your customer number ready when you call. The Service Representative can help you with questions about the operation and maintenance of your machine. He also can schedule you for a service call.

Office Hours:

Country	Monday - Friday	Saturday	Sunday
Poland	7 a.m.- 3 p.m.	Closed	Closed
US	8 a.m.- 5 p.m.	8 a.m.- 12 p.m	Closed

Please have your vehicle identification number and your customer number ready when you call.



Wood-Mizer will accept these methods of payment:

- Visa, Mastercard, or Discover
- COD
- Prepayment
- Net 15 (with approved credit)

Be aware that shipping and handling charges may apply. Handling charges are based on size and quantity of order.

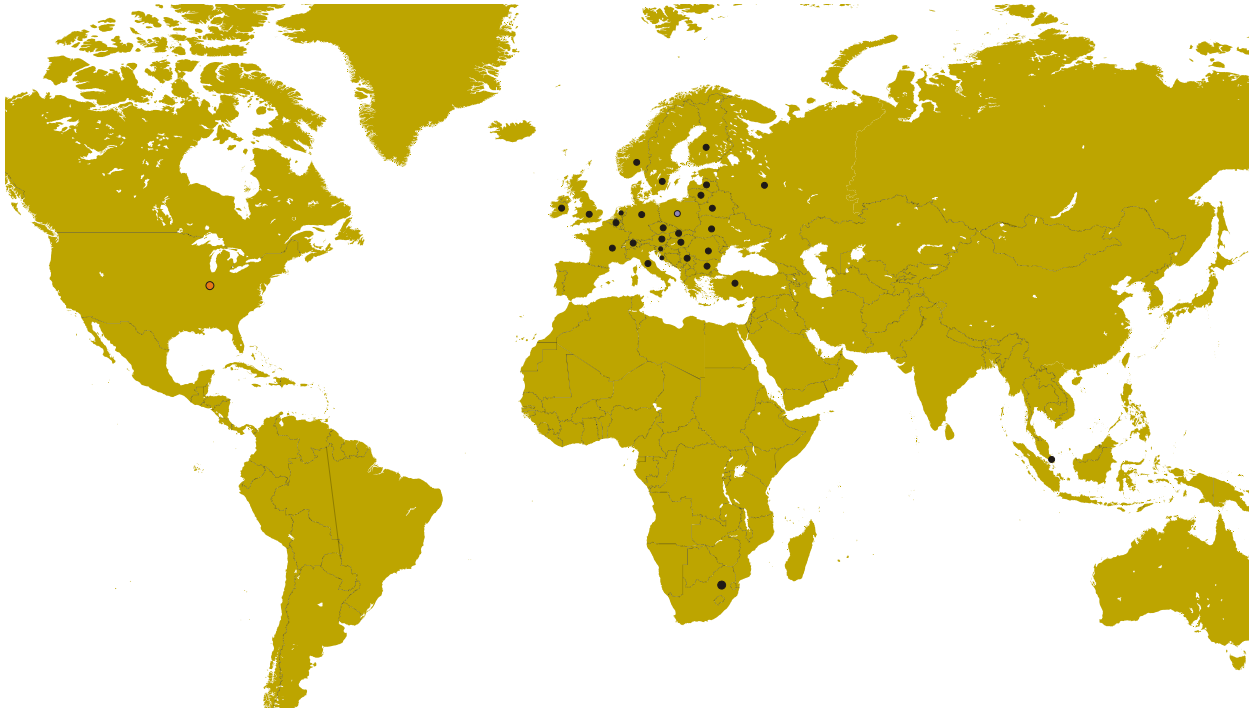
Branches & Authorized Sales Centers



EUROPE		UNITED STATES
<p> European Headquarters Wood-Mizer Industries Sp. z o.o. Nagórna 114, 62-600 Kolo, Poland Tel.: +48-63-26-26-000 Fax: +48-63-27-22-327 www.woodmizer.eu</p>		<p> World Headquarters Wood-Mizer LLC 8180 West 10th Street Indianapolis, Indiana 46214-2400, USA Tel.: +1-317-271-1542 Fax: +1-317-273-1011 www.woodmizer.com</p>
<p>BELARUS MOST-GRUPP Siemashko 15, k.3 Minsk 2200116 Tel.: +375-17-270-90-08 Fax: +375-17-270-90-08 GSM: +375-29-649-90-80 e-mail: most-by@mail.ru</p>	<p>SWITZERLAND Bruno Steiner Striegelgasse 2 CH-6214 Schenkon Tel.: +41-41-921-13-01 Fax: +41-41-922-18-87 e-mail: info@mobilsaegen.ch</p>	<p>RUSSIA Dariusz Mikołajewski OOO WOOD-MIZER INDUSTRIES 141031, Moscow Reg., Mytishenski raj., pos. Veshki, Zavodskaja str., 3B Tel.Fax: +7(495) 788-72-35 Tel.Fax: +7(495) 641-51-60 e-mail: dariuszm@woodmizer-moscow.ru</p>

<p>BULGARIA Kalin Simeonov Ecotechproduct 38 Star Lozenski pat str. Sofia 1186 Tel.: +359-2-462-7035 Tel.: +359-2-963-1656 Tel./Fax : +359-2-979-1710 Kalin Simeonov GSM: +3592-963-2559 e-mail: office@ecotechproduct.com</p>	<p>HUNGARY Wiktor Turoczy Wood-Mizer Hungary K.F.T. Szonyi Ut 67., 2921 Komárom Tel./Fax: +36-34-346-255 e-mail: woodmizer@woodmizer.hu</p>	<p>RUSSIA Far East Wladimir Glazczew "WM Service" Krasnoretchenskaya Str.111 680006 Khabarovsk Tel./Fax: +7-914-541-1183 e-mail: wms-khv@mail.ru</p>
<p>CROATIA Krešimir Pregernik Pregimex d.o.o. S. Batušića 31, 10090 Zagreb Tel./Fax: +3851-38-94-668 Krešimir Pregernik GSM: +3851-98-207-106 e-mail: Kresimir.Pregernik@gmail.com</p>	<p>ITALY Pasquale Felice Wood-Mizer Italia Srl Cda. Capoiaccio SN 86012 Cercemaggiore Campobasso Tel./Fax: +39-0874-798-357 GSM: +39-333-281-03-79 e-mail: wmitaliasrl@gmail.com</p>	<p>SERBIA Dragan Markov Wood-Mizer Balkan d.o.o. Svetosavska GA 3/3; P. Fah 25 23 300 Kikinda Tel./Fax: +381-230-25-754 Tel./Fax: +381-230-23-567 GSM: +381-63-568-658 e-mail: office@woodmizer.co.yu</p>
<p>CZECH REPUBLIC Miroslaw Greill Wood-Mizer CZ s.r.o. Osvaldova 91 339 01 Klatovy-Luby Tel./Fax: +420-376-312-220 Fax: +420-376-319-011 Miroslaw Greill GSM: +420-723-580-799 e-mail: greill@woodmizer.cz</p>		<p>SLOVAKIA Wiktor Turoczy Wood-Mizer Danubia s.r.o. Hadovce 5, 94501 Komárno Tel.: +421-35-77-40-316 Fax: +421-35-7740-326 GSM: +421-905-930-972 e-mail: woodmizer@woodmizer.sk</p>
<p>CZECH REPUBLIC Lubomir Kudlik Wood-Mizer Moravia Sovadinova 6 69002 Breclav Tel./Fax: +420-519-322-443 Lubomir Kudlik GSM: +420-602-734-792 e-mail: info@wood-mizer.net</p>	<p>LATVIA Vilmars Jansons OBERTS Ltd Gaujas str. 32/2 LV-2167 Marupe, Rigas Raj. Tel.: +371-7-810-666 Fax: +371-7-810-655 Vilmars Jansons GSM: +371-92-06-966 Andris Orols GSM: +371-28-33-07-90 e-mail: andris@oberts.lv</p>	<p>TURKEY Er-Ka Ahsap Profil Kerestecilik San. ve Tic. Ltd. Sti. Adana Keresteciler Sitesi 191 sk No.41 ADANA Tel.: +90-322-346-15-86 Fax: +90-322-345-17-07 GSM: +90-533-363-18-44 e-mail: info@erkaahsap.com.tr</p>
<p>FINLAND Howard Blackburn Oy Falkberg Jordbruk Ab Falkintie 220 25610 Ylonkyla Tel.: +358-2732-2253 Fax: +358-2732-2263 Howard Blackburn GSM: +358-440-424-339 e-mail: falkberg@woodmizer.fi</p>	<p>LITHUANIA Andrius Zuzevicius UAB Singlis Savanoriu pr. 187, 2053 Vilnius Tel.: +370-5-2-32-22-44 Fax: +370-5-2-64-84-15 GSM: +370-620-28-645 e-mail: andrius.z@singlis.lt</p> <p>Dmitrij Gaiduk GSM: +370-69-84-51-91 e-mail: dmitrijus.g@singlis.lt</p>	<p>UKRAINE Ivan Vinnicki MOST UKRAINA bul. Myru 3, Bajkivtsi Ternoplskyj r-j Ternopolska oblast 47711 Ukraine Tel/Fax: +38 (0352) 52 37 74 GSM: +38 (067) 352 54 34 GSM: +38 (067) 674 50 68 E-mail: most-ukraine@ukr.net</p>

<p>FRANCE Laurence Serrurier Wood-Mizer France Zac du Prè Marechal Route de Fruges 62560 Fauquembergues Tel: +33-321-930-544 Fax: +33-321-930-990 GSM: +33-607-025-282 Mail: lserrurier@woodmizer.fr</p>	<p>NORWAY Odd Edvoll Wood-Mizer Nordic AS Vardelia 17, 2020 Skedsmokorset Tel.: +47-63-87-49-89 Fax: +47-63-87-37-66 GSM: +47-930-42-335 e-mail: odd.edvoll@woodmizer.no e-mail: firmapost@woodmizer.no</p>	<p>UNITED KINGDOM & IRELAND Wood-Mizer UK Hopfield Barn Kenward Road, Yalding Kent ME18 6JP, UK Tel.: +44-1622-813-201 Fax: +44-1622-815-534 e-mail: info@woodmizer.co.uk</p>
<p>SLOVENIA Jan Fale FAMTEH d.o.o. Gacnikova pot 2, 2390 Ravne na Koroskem Tel.: +386-2-62-04-232 Fax: +386-2-62-04-231 Jan Fale GSM: +386-2-62-04-230 e-mail: jan.fale@famteh.si</p> <p>Matjaz Kolar Tel.: +386-2-62-04-232 GSM: +386-31-775-999 e-mail: matjaz.kolar@famteh.si</p>		<p>David Darnell 10 Tennyson Avenue Southend on Sea Essex, SS2 5HD David Darnell GSM: +44 7799 063 497</p> <p>Stephan Cull Cembrandy Gardens, Manorwen Fishguard, Pembrokeshire SA659PT Tel.: +44-1348-873-179 GSM: +44-7887-544-333</p>
<p>GERMANY Klaus Longmuss Wood-Mizer Sägewerke GmbH Dorfstraße 5, 29485 Schletau Tel.: +49-5883-9880-10 Fax: +49-5883-9880-20 e-mail: info@woodmizer.de</p> <p>Klaus Longmuss Tel.: +49-5883-9880-12 GSM: +49-17-298-55-892 e-mail: KLongmuss@woodmizer.de</p>	<p>Subagent: SWEDEN Kjell Larsson Mekwood AB Slingan 14, 812 41 Gästrike-Hammarby Tel.: +46-290-515-65 Kjell Larsson GSM: +46-706-797-965 e-mail: kjell.larsson@mekwood.se</p>	<p>IRELAND Wood-Mizer Ireland Stephen Brennan Cum Lahardane Ballina County Mayo Tel:+353 96 51345 E-mail: brennanmill@ericom.net</p>
<p>Subagents: DENMARK Brian Jensen Arnborgvej 9, 7330 Brande- Fasterholt Tel.: +45-971-88-265 Fax: +45-971-88-266 Brian Jensen GSM: +45-23-49-5828 e-mail: Fasterholt-Savvaerk@Mail.Tele.dk</p>	<p>ROMANIA Adrian Echert SC WOOD-MIZER RO SRL TRANSILVANIEI Nr. 5 Sibiu, Cisnadie 555300 Tel./Fax: : +40-369-405-433 GSM: +40-745-707-323 e-mail: aeichert@woodmizer.ro</p>	<p>Regional Manager - Asia Wood-Mizer Asia Pte Ltd. James Wong Tel: +65 81216910 Fax: +65 6283 8636 WWW: www.woodmizerasia.com E-mail: jwong@woodmizerasia.com</p>
<p>Netherlands Chris Dragt Lange Brink 77d, 7317 BD Apeldoorn Tel.: +31-55312-1833 Fax: +31-55312-2042 e-mail: Info@dragtbosbouw.nl</p>	<p>Subagent: ROMANIA M. Echert S.C. Echert Comprod s.r.l Str. Schitului Nr. 6, Apt.7 etajul-1 725 70 Vatra Dornei, Romania Tel./Fax: +40-230-374-235 Tel. : +40-740-35-35-74</p>	<p>Regional Manager - Africa Wood-Mizer Africa Jean-Jacques Oelofse UNIT 3, LEADER PARK, NO: 20 CHARIOT ROAD STORMILL, EXT 5, Roodepoort, Johannesburg Tel: +27 011 473 1313 Fax: +27 011 473 2005 Jean-Jacques Oelofse E-mail: jjoelofse@woodmizerafrika.com Jean-Jacques Oelofse Skype:jean.jacques.pierre.oelofse</p>

Sawmill and Customer Identification

Each Wood-Mizer sawmill has a 17-digit Vehicle Identification Number (VIN). See the figure below for VIN locations. See the chart for VIN description.

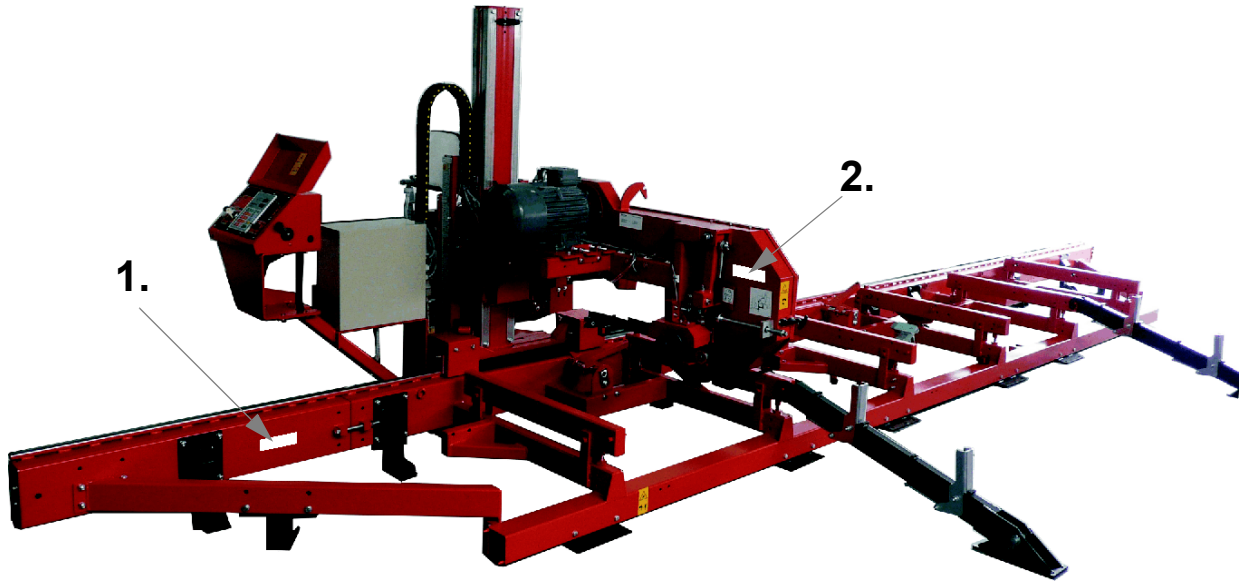

V.I.N. LOCATIONS

456	Company Identification Number 456=Wood-Mizer Indiana		Weight Class; A=Under 1361 kg, B=1361-1814 kg, C=1814-2268 kg, D=2269-3000kg	Product No.; 1=LT10/15, 2=LT20 Series, 4=LT40 Series, 7=LT70 Series	Length of the Trailer; 20= 20' (6 m), 24=24' (7 m), 35=35' (11 m)	Number of axles on the trailer	Check Digit Add all the number and divide by 11	Year of Manufacture; G=2009, H=2010, J=2011, K=2012, L=2013, M=2014	State of Manufacture N=Indiana, P=Poland	Month of Manufacture A=January, B=February, C=March, etc...	Revision Level	Sequence Number Ranging from 000-999	End of 17-Digit VIN	Revision Level (Repeated)	Two-Digit Minor Revision Level
456	A	4	24	1	X	H	P	A	F9	017		F9	.01		

V.I.N. DESCRIPTION

Each sawmill is also identified with a model number which includes the base model and the engine/motor configuration. See the figure for a description of the model number.

LT20B
Basic Sawmill I.D.

E15
Engine/Motor
Configuration

MODEL NUMBER DESCRIPTION

When you pick up your mill, you will receive a customer number. Both the VIN and your customer number expedite our service to you. Please write these numbers below so you have quick, easy access to them.

Customer No.	Model No.	V.I.N.	Revision

Getting Service

Wood-Mizer is committed to providing you with the latest technology, best quality and strongest customer service available on the market today. We continually evaluate our customers' needs to ensure we're meeting current wood-processing demands. Your comments and suggestions are welcome.

General Contact Information

From Europe call your local distributor or our European Headquarters and Manufacturing Facility in Koło, Nagórna 114 St, Poland at **+48-63-2626000**. From the continental U.S., call our U.S. Headquarter 8180 West 10th St. Indianapolis, IN 46214, toll-free at **1-800-525-8100**. Ask to speak with a Customer Service Representative. Please have your machine identification number and your customer number ready when you call. The Service Representative can help you with questions about the operation and maintenance of your machine. He also can schedule you for a service call.

Office Hours:

Country	Monday - Friday	Saturday	Sunday
Poland	7 a.m.- 3 p.m.	Closed	Closed
US	8 a.m.- 5 p.m.	8 a.m.- 12 p.m	Closed

Please have your vehicle identification number and your customer number ready when you call.



Wood-Mizer will accept these methods of payment:

- Visa, Mastercard, or Discover
- COD
- Prepayment
- Net 15 (with approved credit)

Be aware that shipping and handling charges may apply. Handling charges are based on size and quantity of order.

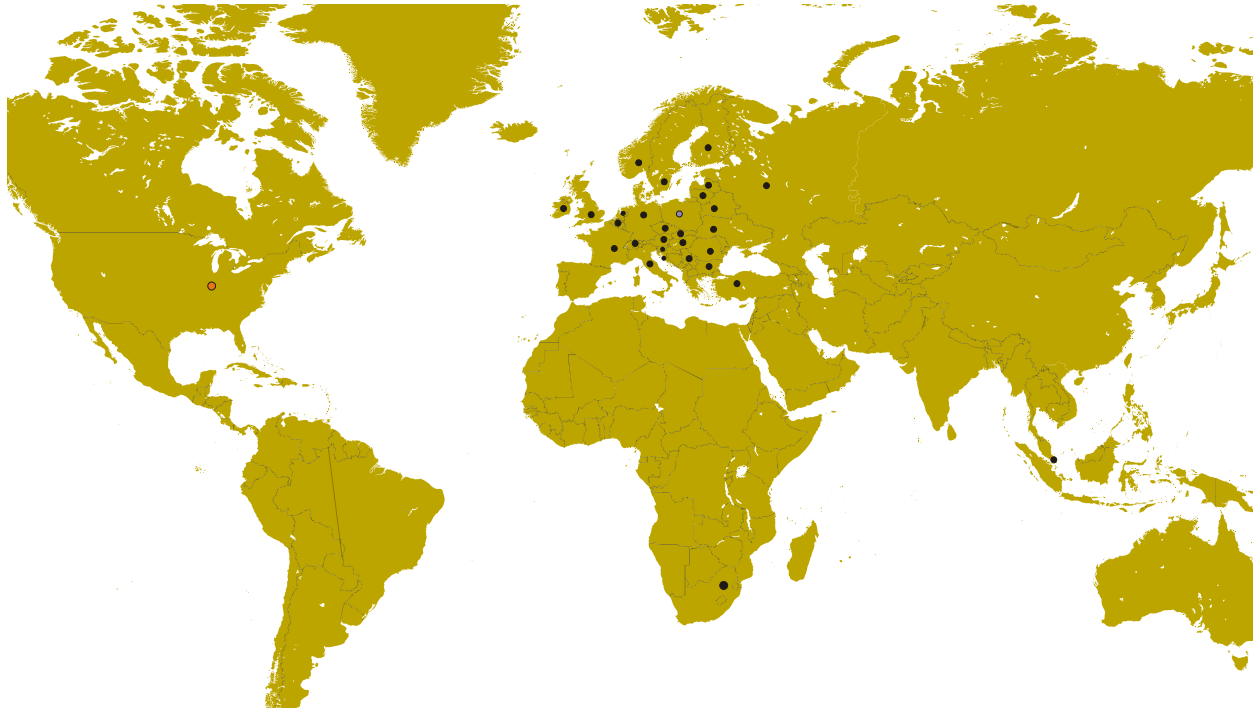
Branches & Authorized Sales Centers



EUROPE		UNITED STATES
<p> European Headquarters Wood-Mizer Industries Sp. z o.o. Nagórna 114, 62-600 Kolo, Poland Tel.: +48-63-26-26-000 Fax: +48-63-27-22-327 www.woodmizer.eu</p>		<p> World Headquarters Wood-Mizer LLC 8180 West 10th Street Indianapolis, Indiana 46214-2400, USA Tel.: +1-317-271-1542 Fax: +1-317-273-1011 www.woodmizer.com</p>
<p>BELARUS MOST-GRUPP Siemashko 15, k.3 Minsk 2200116 Tel.: +375-17-270-90-08 Fax: +375-17-270-90-08 GSM: +375-29-649-90-80 e-mail: most-by@mail.ru</p>	<p>SWITZERLAND Bruno Steiner Striegelgasse 2 CH-6214 Schenkon Tel.: +41-41-921-13-01 Fax: +41-41-922-18-87 e-mail: info@mobilsaegen.ch</p>	<p>RUSSIA Dariusz Mikołajewski OOO WOOD-MIZER INDUSTRIES 141031, Moscow Reg., Mytishenski raj., pos. Veshki, Zavodskaja str., 3B Tel.Fax: +7(495) 788-72-35 Tel.Fax: +7(495) 641-51-60 e-mail: dariuszm@woodmizer-moscow.ru</p>

1 Introduction

Branches & Authorized Sales Centers

<p>BULGARIA Kalin Simeonov Ecotechproduct 38 Star Lozenski pat str. Sofia 1186 Tel.: +359-2-462-7035 Tel.: +359-2-963-1656 Tel./Fax : +359-2-979-1710 Kalin Simeonov GSM: +3592-963-2559 e-mail: office@ecotechproduct.com</p>	<p>HUNGARY Wiktor Turoczy Wood-Mizer Hungary K.F.T. Szonyi Ut 67., 2921 Komárom Tel./Fax: +36-34-346-255 e-mail: woodmizer@woodmizer.hu</p>	<p>RUSSIA Far East Wladimir Glazaczew "WM Service" Krasnoretchenskaya Str.111 680006 Khabarovsk Tel./Fax: +7-914-541-1183 e-mail: wms-khv@mail.ru</p>
<p>CROATIA Krešimir Pregernik Pregimex d.o.o. S. Batušića 31, 10090 Zagreb Tel./Fax: +3851-38-94-668 Krešimir Pregernik GSM: +3851-98-207-106 e-mail: Kresimir.Pregernik@gmail.com</p>	<p>ITALY Felice Pasquale Wood-Mizer Italia Srl Cda. Capoiaccio SN 86012 Cercemaggiore Campobasso Tel./Fax: +39-0874-798-357 GSM: +39-333-281-03-79 e-mail: wmitaliasrl@gmail.com</p>	<p>SERBIA Dragan Markov Wood-Mizer Balkan d.o.o. Svetosavska GA 3/3; P. Fah 25 23 300 Kikinda Tel./Fax: +381-230-25-754 Tel./Fax: +381-230-23-567 GSM: +381-63-568-658 e-mail: office@woodmizer.co.yu</p>
<p>CZECH REPUBLIC Miroslaw Greill Wood-Mizer CZ s.r.o. Osvaldova 91 339 01 Klatovy-Luby Tel./Fax: +420-376-312-220 Fax: +420-376-319-011 Miroslaw Greill GSM: +420-723-580-799 e-mail: greill@woodmizer.cz</p>	<p>Subagent: ITALY Franz Josef Reichsigl Muls 21, 39058 Samnthein Tel./Fax: +39-471-627-264 GSM: +39-335-824-88-05</p>	<p>SLOVAKIA Wiktor Turoczy Wood-Mizer Danubia s.r.o. Hadovce 5, 94501 Komárno Tel.: +421-35-77-40-316 Fax: +421-35-7740-326 GSM: +421-905-930-972 e-mail: woodmizer@woodmizer.sk</p>
<p>CZECH REPUBLIC Lubomir Kudlik Wood-Mizer Moravia Sovadinova 6 69002 Breclav Tel./Fax: +420-519-322-443 Lubomir Kudlik GSM: +420-602-734-792 e-mail: info@wood-mizer.net</p>	<p>LATVIA Vilmars Jansons OBERTS Ltd Gaujas str. 32/2 LV-2167 Marupe, Rigas Raj. Tel.: +371-7-810-666 Fax: +371-7-810-655 Vilmars Jansons GSM: +371-92-06-966 Andris Orols GSM: +371-28-33-07-90 e-mail: andris@oberts.lv</p>	<p>TURKEY Er-Ka Ahsap Profil Kerestecilik San. ve Tic. Ltd. Sti. Adana Keresteciler Sitesi 191 sk No.41 ADANA Tel.: +90-322-346-15-86 Fax: +90-322-345-17-07 GSM: +90-533-363-18-44 e-mail: info@erkaahsap.com.tr</p>
<p>FINLAND Howard Blackburn Oy Falkberg Jordbruk Ab Falkintie 220 25610 Ylonkyla Tel.: +358-2732-2253 Fax: +358-2732-2263 Howard Blackburn GSM: +358-440-424-339 e-mail: falkberg@woodmizer.fi</p>	<p>LITHUANIA Andrius Zuzevicius UAB Singlis Savanoriu pr. 187, 2053 Vilnius Tel.: +370-5-2-32-22-44 Fax: +370-5-2-64-84-15 GSM: +370-620-28-645 e-mail: andrius.z@singlis.lt Dmitrij Gaiduk GSM: +370-69-84-51-91 e-mail: dmitrijus.g@singlis.lt</p>	<p>UKRAINE Ivan Vinnicki MOST UKRAINA bul. Myru 3, Bajkivtsi Ternoplskyj r-j Ternopolska oblast 47711 Ukraine Tel/Fax: +38 (0352) 52 37 74 GSM: +38 (067) 352 54 34 GSM: +38 (067) 674 50 68 E-mail: most-ukraine@ukr.net</p>

<p>FRANCE Laurence Serrurier Wood-Mizer France Zac du Prè Marechal Route de Fruges 62560 Fauquembergues Tel: +33-321-930-544 Fax: +33-321-930-990 GSM: +33-607-025-282 Mail: lserrurier@woodmizer.fr</p>	<p>NORWAY Odd Edvoll Wood-Mizer Nordic AS Vardelia 17, 2020 Skedsmokorset Tel.: +47-63-87-49-89 Fax: +47-63-87-37-66 GSM: +47-930-42-335 e-mail: odd.edvoll@woodmizer.no e-mail: firmapost@woodmizer.no</p>	<p>UNITED KINGDOM & IRELAND Wood-Mizer UK Hopfield Barn Kenward Road, Yalding Kent ME18 6JP, UK Tel.: +44-1622-813-201 Fax: +44-1622-815-534 e-mail: info@woodmizer.co.uk</p>
<p>SLOVENIA Jan Fale FAMTEH d.o.o. Gacnikova pot 2, 2390 Ravne na Koroskem Tel.: +386-2-62-04-232 Fax: +386-2-62-04-231 Jan Fale GSM: +386-2-62-04-230 e-mail: jan.fale@famteh.si</p> <p>Matjaz Kolar Tel.: +386-2-62-04-232 GSM: +386-31-775-999 e-mail: matjaz.kolar@famteh.si</p>		<p>David Darnell 10 Tennyson Avenue Southend on Sea Essex, SS2 5HD David Darnell GSM: +44 7799 063 497</p> <p>Stephan Cull Cembrandy Gardens, Manorwen Fishguard, Pembrokeshire SA659PT Tel.: +44-1348-873-179 GSM: +44-7887-544-333</p>
<p>GERMANY Klaus Longmuss Wood-Mizer Sägewerke GmbH Dorfstraße 5, 29485 Schletau Tel.: +49-5883-9880-10 Fax: +49-5883-9880-20 e-mail: info@woodmizer.de</p> <p>Klaus Longmuss Tel.: +49-5883-9880-12 GSM: +49-17-298-55-892 e-mail: KLongmuss@woodmizer.de</p>	<p>Subagent: SWEDEN Kjell Larsson Mekwood AB Slingan 14, 812 41 Gästrike-Hammarby Tel.: +46-290-515-65 Kjell Larsson GSM: +46-706-797-965 e-mail: kjell.larsson@mekwood.se</p>	<p>IRELAND Wood-Mizer Ireland Stephen Brennan Cum Lahardane Ballina County Mayo Tel:+353 96 51345 E-mail: brennanmill@ericom.net</p>
<p>Subagents: DENMARK Brian Jensen Arnborgvej 9, 7330 Brande- Fasterholt Tel.: +45-971-88-265 Fax: +45-971-88-266 Brian Jensen GSM: +45-23-49-5828 e-mail: Fasterholt-Savvaerk@Mail.Tele.dk</p>	<p>ROMANIA Adrian Echert SC WOOD-MIZER RO SRL TRANSILVANIEI Nr. 5 Sibiu, Cismadie 555300 Tel./Fax: : +40-369-405-433 GSM: +40-745-707-323 e-mail: aechert@woodmizer.ro</p>	<p>Regional Manager - Asia Wood-Mizer Asia Pte Ltd. James Wong Tel: +65 81216910 Fax: +65 6283 8636 WWW: www.woodmizerasia.com E-mail: jwong@woodmizerasia.com</p>
<p>Netherlands Chris Dragt Lange Brink 77d, 7317 BD Apeldoorn Tel.: +31-55312-1833 Fax: +31-55312-2042 e-mail: Info@dragtbosbouw.nl</p>	<p>Subagent: ROMANIA M. Echert S.C. Echert Comprod s.r.l Str. Schitului Nr. 6, Apt.7 etajul-1 725 70 Vatra Dornei, Romania Tel./Fax: +40-230-374-235 Tel. : +40-740-35-35-74</p>	<p>Regional Manager - Africa Wood-Mizer Africa Jean-Jacques Oelofse UNIT 3, LEADER PARK, NO: 20 CHARIOT ROAD STORMILL, EXT 5, Roodepoort, Johannesburg Tel: +27 011 473 1313 Fax: +27 011 473 2005 Jean-Jacques Oelofse E-mail: jjoelofse@woodmizerafrika.com Jean-Jacques Oelofse Skype: jean.jacques.pierre.oelofse</p>

SECTION 1 SAFETY & GENERAL INFORMATION



This symbol calls your attention to instructions concerning your personal safety. Be sure to observe and follow these instructions. This symbol accompanies a signal word. The word **DANGER** indicates an imminently hazardous situation which, if not avoided, will result in death or serious injury. **WARNING** suggests a potentially hazardous situation which, if not avoided, could result in death or serious injury. **CAUTION** refers to potentially hazardous situations which, if not avoided, may result in minor or moderate injury to persons or equipment. Read all safety instructions before operating this equipment and observe all safety warnings!



Warning stripes are placed on areas where a single decal would be insufficient. To avoid serious injury, keep out of the path of any equipment marked with warning stripes.

Read and observe all safety instructions before operating this equipment! Also read any additional manufacturer's manuals and observe any applicable safety instructions including dangers, warnings, and cautions.

Always be sure that all safety decals are clean and readable. Replace all damaged safety decals to prevent personal injury or damage to the equipment. Contact your local distributor, or call your Customer Service Representative to order more decals.

IMPORTANT! It is always the owner's responsibility to comply with all applicable federal, state and local laws, rules and regulations regarding the ownership, operation and towing of your Wood-Mizer sawmill. All Wood-Mizer mill owners are encouraged to become thoroughly familiar with these applicable laws and comply with them fully while using or towing the mill.

Always properly dispose of all sawing by-products, including sawdust and other debris, coolant, oil, fuel, oil filters and fuel filters.

Safety instructions are listed in this section by the following operations:

- Blade Handling
- Sawmill Setup
- Sawmill Operation
- Sawmill Maintenance

1.1 Blade Handling



DANGER! Always disengage the blade and shut off the sawmill engine before changing the blade. Failure to do so will result in serious injury.



WARNING! Always wear gloves and eye protection when handling bandsaw blades. Changing blades is safest when done by one person! Keep all other persons away from area when coiling, carrying or changing a blade. Failure to do so may result in serious injury.



WARNING! Do not spin the blade wheels by hand. Spinning the blade wheels by hand may result in serious injury.

1 Safety & General Information

Sawmill Setup

1.2 Sawmill Setup



WARNING! Securely fasten the feet of a stationary sawmill to the floor before operating the sawmill. Failure to do so may result in serious injury or death.

WARNING! Always make sure the trailer is supporting the sawmill frame when operating a sawmill with adjustable outriggers. Failure to do so may result in serious injury or death. The adjustable outriggers are intended to support the saw frame with assistance from the trailer.

WARNING! Do not set up the mill on ground with more than a 10 degree incline. If setup on an incline is necessary, put blocks under one side of the mill or dig out areas for outrigger legs to keep mill level. Setting up the mill on an incline could cause it to tip over, resulting in serious personal injury.



CAUTION! Changes in temperature could cause increased pressure in the blade tensioner and loss of fluid from the gauge. Release the blade tension when the mill is not in use to avoid damage to the tensioner.

1.3 Sawmill Operation



DANGER! Make sure all guards and covers are in place and secured before operating or towing the sawmill. Failure to do so may result in serious injury.

Be sure the blade housing and pulley covers are in place and secure. Use the safety retainer pin and cable to fasten blade housing covers.

DANGER! Always keep hands away from moving bandsaw blade. Failure to do so will result in serious injury.

DANGER! Stay clear of the area between the trailer axle and saw carriage. Failure to do so will result in serious injury.

DANGER! Keep all persons out of the path of moving equipment and logs when operating sawmill or loading and turning logs. Failure to do so will result in serious injury.

DANGER! Maintain a clean and clear path for all necessary movement around the mill and lumber stacking areas. Failure to do so will result in serious injury.

DANGER! Always be sure the blade is disengaged and all persons are out of the path of the blade before starting the engine or motor. Failure to do so will result in serious injury.

DANGER! Keep all persons out of the path of returning boards. Failure to do so will result in serious injury.



WARNING! Always disengage the clutch/brake mechanism whenever the sawmill is not cutting. Failure to do so may result in serious injury.

WARNING! Always wear eye, ear, respiration, and foot protection when operating the sawmill. Failure to do so may result in serious injury.



WARNING! Secure all loose clothing and jewelry before operating the sawmill. Failure to do so may result in serious injury or death.

1

Safety & General Information

Sawmill Operation

WARNING! Always make sure log is clamped securely before sawing. Failure to do so may result in serious injury or death.

WARNING! Use ONLY water with the water lube accessory. Never use flammable fuels or liquids. If these types of liquids are necessary to clean the blade, remove it and clean with a rag. Failure to do so may result in serious injury or death. When cutting in freezing temperatures, use anti-freeze, non-flammable additive.



CAUTION! Be sure the pivot rails, turning arm, clamp, and toe boards are below bed level before loading a log onto the bed. Failure to do so may result in machine damage or cause misalignment.

CAUTION! Before loading a log, be sure the cutting head is moved far enough forward so the log does not hit it. Failure to do so may result in machine damage.

CAUTION! Do not try to force the saw head beyond its upper and lower travel limits. Damage to the up/down system may result.

CAUTION! Do not use the blade guide arm knob to move the carriage head forward and backward. Damage to the blade guide arm may result.

CAUTION! Be sure to stop the blade when returning the carriage. This will not only prevent the blade from being pulled off and ruined by a wood sliver, but also will increase the life of the blade.

CAUTION! The sawmill's work-stand should be equipped with a 4 kg or bigger dry powder extinguisher.

CAUTION! If at any time you need to immediately stop the blade engine, press the emergency stop button located on the control box.

CAUTION! Sawmill can be operated with sawdust extraction system only.

1.4 Sawmill Maintenance



WARNING! Always secure the cutting head with a chain or a brace before adjusting the up/down chain. The cutting head may fall, causing severe injury or death.

WARNING! Always secure the cutting head with a chain or a brace before adjusting the mast pads. The cutting head may fall, causing severe injury or death.

CAUTION! Reinstall the track wiper so that it lightly touches the track rail. If the wiper presses too firmly against the rail, it can cause the power feed to bind.

CAUTION! Never use grease on the mast rails as it will collect sawdust.

CAUTION! Do not use chain lube. It causes sawdust buildup in chain links.

CAUTION! Due to variations in the vertical mast, the pad spacing may vary throughout the travel of the saw head. Check the pad spacing at the top and bottom ends of the mast only. Pads adjusted too tight will cause premature up/down motor failure.

CAUTION! It is important that the lower stop bolts are properly adjusted to secure the carriage on the track rail. Failure to properly adjust the stop bolts can cause saw head damage, especially during mill transportation.

1 Safety & General Information

Sawmill Maintenance

See Table 1-1. Pictogram decals used to warn and inform the user about danger.

TABLE 1-1



Decal View	W-M No.	Description
	096317	CAUTION! Read thoroughly the manual before operating the machine. Observe all safety instructions and rules when operating the sawmill.
	099220	CAUTION! Close all guards and covers before starting the machine.
	099219	Blade tension. Turning the bolt clockwise will increase the blade tension and turning the bolt counterclockwise will decrease the tension.

TABLE 1-1

<p>099221</p>	<p>099221</p>	<p>CAUTION! Keep all persons a safe distance away from work area when operating the machine.</p>
<p>098176</p>	<p>098176</p>	<p>CAUTION! Keep away from debarker blade!</p>
<p>096316</p>	<p>096316</p>	<p>CAUTION! Do not open or close the electric box when the switch is not in the "0" position.</p>

1 Safety & General Information

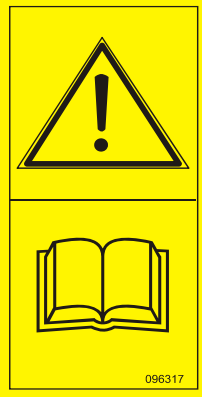
Sawmill Maintenance

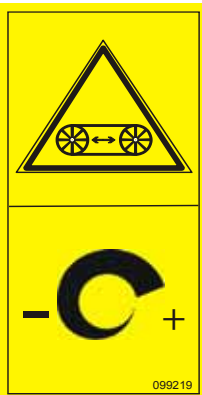
TABLE 1-1







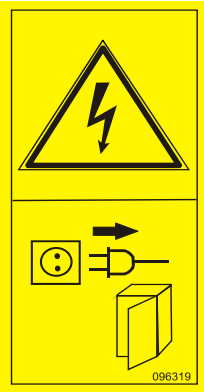
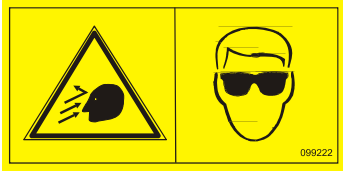
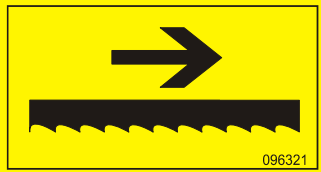

 <p>096319</p>	<p>096319</p>	<p>CAUTION! Disconnect power supply before opening the box.</p>
 <p>099222</p>	<p>099222</p>	<p>CAUTION! Sawdust outlet. Protect eyes!</p>
 <p>096321</p>	<p>096321</p>	<p>Blade movement direction</p>
	<p>S12004G</p>	<p>CAUTION! Always wear safety goggles when operating the sawmill!</p>

TABLE 1-1

	<p>S12005G</p>	<p>CAUTION! Always wear protective ear muffs when operating the sawmill!</p>
	<p>501465</p>	<p>CAUTION! Always wear safety boots when operating the sawmill</p>
	<p>501467</p>	<p>Lubrication point</p>
 <p>P11789b</p>	<p>P11789</p>	<p>Aligning the blade on the wheels</p>
 <p>092597</p>	<p>092597</p>	<p>Setting the blade tension indicator</p>

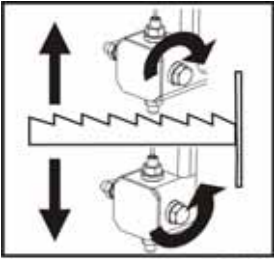
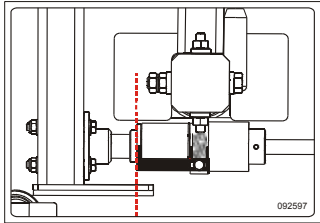
1 Safety & General Information
Sawmill Maintenance

TABLE 1-1

	P85070	CE safety certification
	099401	Russian safety certification
	S20097A	3600 r.p.m. - motor rotation direction
	S20097F	2925 r.p.m. - motor rotation direction

1.5 Belt Sizes

See Table 1-2. Belt sizes for the LT20 sawmill are shown.

Description	Belt Size	Wood-Mizer Part #
Motor Drive Belt E11 & E15	2BX81	014819-2
Engine Drive Belt D22, G25	2BX84	088110
Blade Pulley Belts	B57 ¹	P04185

TABLE 1-2

¹ To insure proper blade tracking, use Goodyear, Dayco Super II, or Browning belts only.

1.6 Blade Sizes

See *The Blade Handbook* for blade hook angle, tooth height, and tooth set specifications.

1.7 Cutting Capacity

See Table 1-3. The log size capacities of the LT20 series sawmill are listed below.

	Max. Diameter ¹	Max. Length ¹
LT20B1E15SMH	71 cm	3.1 m
LT20B1E15SMH with debarker	71 cm	2.8 m
LT20B2E15SMH	71 cm	5.1 m
LT20B2E15SMH with debarker	71 cm	4.8 m
LT20B3E15SMH	71 cm	7.1 m
LT20B3E15SMH with debarker	71 cm	6.8 m
LT20B4E15SMH	71 cm	9.1 m
LT20B4E15SMH with debarker	71 cm	8.8 m

TABLE 1-3

¹ Maximum log capacity for a basic mill is 2000 Kg.

1 Safety & General Information

Engine/Motor Specifications

See Table 1-4. The performance capacity of the LT20 series sawmill is listed below. Peak cutting rates are measured in 12" (30 cm) wide red oak and represent the capability of the sawmill only. Rates based on using Tru-Sharp 1 1/4" x .042 blades.

Model	Linear Blade Speed	Maximum Cutting Speed
LT20B3E15SMH	---	5.2 m/min.

TABLE 1-4

1.8 Engine/Motor Specifications

See Table 1-5. The power options available for the LT20 Series sawmill are listed below.

Engine/Motor Type	Manufacturer	Model No.	Power	Other Specifications
11HP Electric	Tamel SA, Poland	Sg 132S-2B HM	7.5 kW	14.5 A, 2925 r.p.m.
15HP Electric	Tamel SA, Poland	Sg 132S-2PC HM	11 kW	22.3 A 2920 r.p.m.
22HP Diesel	Kubota	D1005	22 HP	3600 r.p.m.
25HP Gasoline	Kohler	CH25	25HP	3600 RPM, 725 cm ³

TABLE 1-5

See Table 1-6. See the table below for power supply specifications for the LT20 sawmill.

3-Phase Volts	Fused Disconnect Switch	Recommended Wire Size
400 VAC	25 Amp	4 mm ² up to 15 m of length

TABLE 1-6



DANGER! It is recommended that a 30mA Ground Fault Interrupter (GFI) be used.

1.9 Noise Level

See Table 1-7. The average noise level is given in the table below¹²³.

Sawmill	Noise Level
LT20B3E15SMH	$L_{EX8} = 82 \text{ dB (A)}$
LT20B3D22SMH	$L_{EX8} = 85,6 \text{ dB (A)}$

TABLE 1-7

1.10 Overall Dimensions

See Table 1-8. The overall dimensions of the LT20 sawmill are listed below.

Model	Length	Width Operating Position	Height	Weight
LT20B1E15SMH	4.35 m	3.2 m	2.3 m	870 kg
LT20B2E15SMH	6.35 m	3.2 m	2.3 m	1048 kg
LT20B3E15SMH	8.35 m	3.2 m	2.3 m	1226 kg
LT20B4E15SMH	10.35 m	3.2 m	2.3 m	1404 kg

TABLE 1-8

1. The noise level measurement was taken in accordance with PN-EN ISO 3746 Standard. The noise exposure level given above concerns an 8-hour work day.
2. The measured values refer to emission levels, not necessarily to noise levels in the workplace. Although there is a relation between emission levels and exposure levels, it is not possible to determine with certainty if preventives are needed or are not needed. The factors affecting a current level of noise exposure during work are inter alia room characteristics and characteristics of other noise sources, e.g. number of machines and machining operations nearby. Also, the permissible exposure level value may vary depending on country. This information enables the machine's user to better identify hazards and a risk.
3. It is necessary to perform the noise level measurement by the customer in the work place, after sawmill installation.

1 Safety & General Information

Overall Dimensions (Packed)

1.11 Overall Dimensions (Packed)

See Table 1-9. The overall dimensions (packed) of the LT20 sawmill for transporting.

Model	Length	Width	Height
LT20B1-4 E15SMH	2.13 m	2 m	2,3 m
LT20B1-4 E15SRC	2.13 m	2 m	2.83 m

TABLE 1-9

1.12 Chains

See Table 1-10. The load capacity of the chains is listed below.

	Load Capacity According to ISO No 08A-1
Up/Down Chain	2270KG

TABLE 1-10

1.13 Sawdust Extractor Specifications

See Table 1-11. The dust extractor specifications are given below.

Maximum Capacity	1200 m ³ /h
Collector Inlet Diameters (in front of fan)	150 mm
Motor Power	1.5 kW
Number of Sacks for Waste	1
Total Capacity of Sacks	0.25 m ³
Weight	110 kg
Conveying Speed When 10 m Long Hose Is Used	20 m/s

TABLE 1-11

1.14 Components

See Figure 1-1. The major components of the LT20 sawmill are shown below.

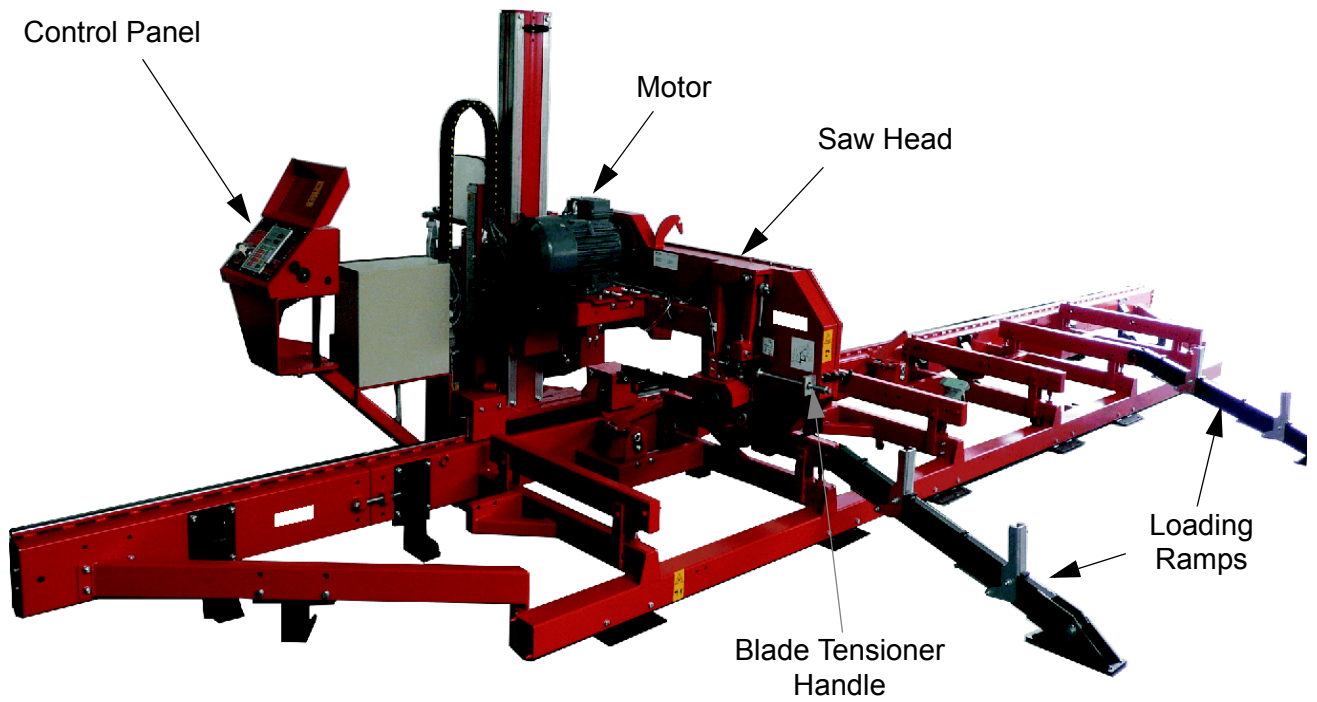

FIG. 1-1

2

SAWMILL ASSEMBLY

Mounting Parts of LT20 Sawmills with Electric Motors

SECTION 2 SAWMILL ASSEMBLY

2.1 Mounting Parts of LT20 Sawmills with Electric Motors

2.1.1 Parts specifications

Table 1:

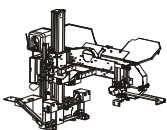

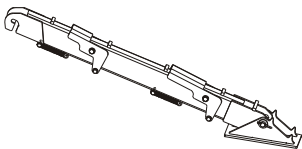
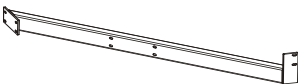
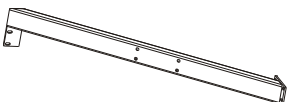

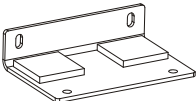

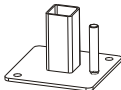
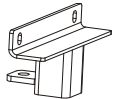
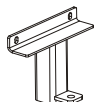
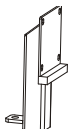
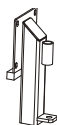
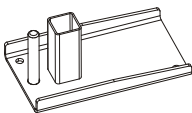
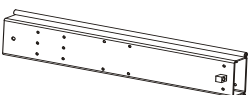
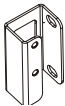
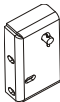

Fig.	Wood-Mizer Part No.	Description	Qty. LT20B3
	090676	Sawmill Saw Head	1
	096726	Motor Kit	1
	100634	Log Ramp (Optional Equipment)	2
	100551-1	Side Tube, Front	1
	100545-1	Side Tube, Back	1
	100536-1	Leg, Long (non-adjustable legs kit)	7
	100550-1	Leg, Short (non-adjustable legs kit)	6
	100868-1	Leg, Side (non-adjustable legs kit)	2

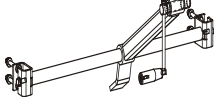
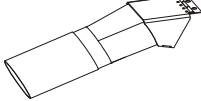
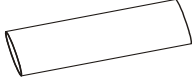
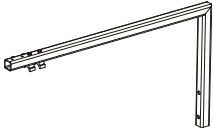

Table 1:

	101186-1	Leg, Long with Tube (non-adjustable legs kit)	1
	099281-1	Foot Assembly (adjustable legs kit)	16
	100553-1	Leg, Short (adjustable legs kit)	6
	100554-1	Leg, Side (adjustable legs kit)	2
	100559-1	Leg, Long (adjustable legs kit)	7
	101187-1	Leg, Long with Tube (adjustable legs kit)	1
	500775-1	Leg, Wide (adjustable legs kit)	8
	099728-1	Bed Extension, LES	2
	087105-1	Bumper Bracket	1
	091828	Bumper	1
	015023	Cover	1

2 SAWMILL ASSEMBLY

Parts specifications

Table 1:

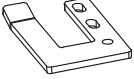
	510230	Clamp, Complete	Depends on order
	100903-1	Sawdust Chute Weldment	1
	100999	Tube, Sawdust Chute Rubber	1
	091598-1	Power Cord Bracket	1
	089712-1	Bumper Bracket	1
	091852-1	Limit Switch Bracket	1

2.1.2 Specifications of Fasteners

Table 2:

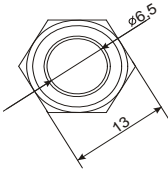
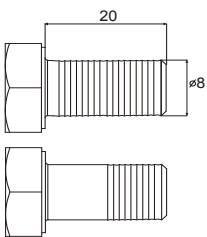
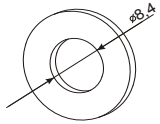
Wood-Mizer No.	Description	Qty. LT20B3
Sample designations of fasteners:		
<div style="display: flex; justify-content: space-around; align-items: flex-start;"> <div style="text-align: center;"> <p>M8 Nut</p>  </div> <div style="text-align: center;"> <p>M8x20 Bolt</p>  </div> <div style="text-align: center;"> <p>8.4 Washer</p>  </div> </div>		
F81036-1	NUT, M16-5.8 HEX ZINC	36
F81055-1	WASHER, 10.5 FLAT ZINC	56
F81033-1	NUT, M10-8-B HEX NYLON ZINC LOCK	44
F81003-33	BOLT, M10X120 8.8 CARRIAGE ZINC	24
F81003-18	BOLT, M10 X 125-8.8 HEX HEAD ZINC	8
F81003-15	BOLT, M10x75-8.8 HEX HEAD ZINC	4
F81058-1	WASHER, 17 FLAT ZINC	42
F81056-1	WASHER, M12 FLAT ZINC	26
F81034-2	NUT, M12-8 HEX NYLON ZINC LOCK	2
F81034-1	NUT, M12-8-B HEX ZINC	2
F81006-23	BOLT, M16X160-8.8 HEX HEAD ZINC	4
F81004-55	BOLT, M12X130-8.8 HEX HEAD ZINC	4
F81004-45	BOLT, M12X100-8.8 HEX HEAD ZINC	2
F81004-12	BOLT, M12X55-8.8 HEX HEAD ZINC	4
F81003-34	BOLT, M10X125 CARRIAGE	8

2

SAWMILL ASSEMBLY

Tools Necessary for Assembling the Sawmill

2.1.3 *Tools Necessary for Assembling the Sawmill*

Table 3:

Required Tools	
Flat Wrench #8	1 pcs
Flat Wrench #10	2 pcs
Flat Wrench #13	2 pcs
Flat Wrench #17	2 pcs
Flat Wrench #19	2 pcs
Ratchet Wrench #30	1 pcs
Hammer	1 pcs
Allen Wrench #4	1 pcs
Allen Wrench #5	1 pcs

2.2 Unpacking the Sawmill



IMPORTANT! Machine can be lifted only with forklift. Use forklift with lifting capacity of minimum 2000kg, and forks length of minimum 2m.

2.2.1 *Standard version of the Sawmill.*

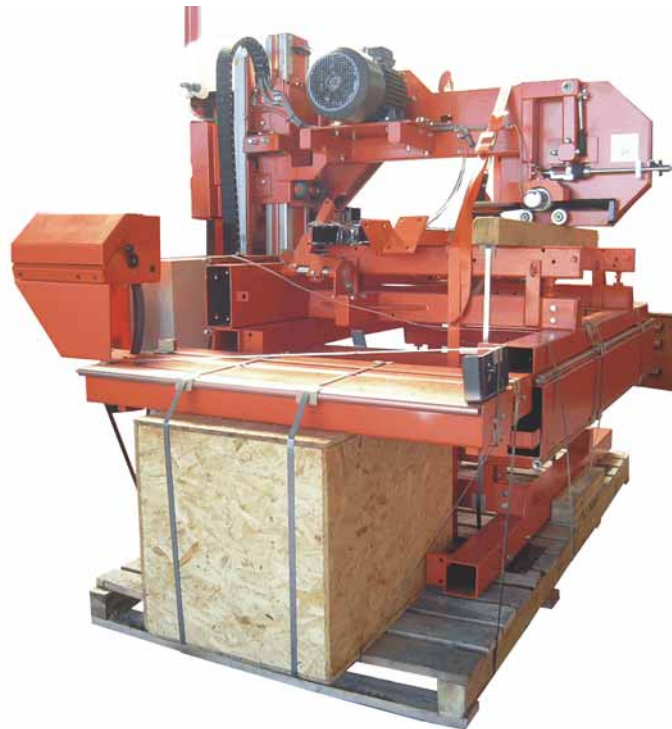

FIG. 2-0

2.2.2 Sawmill with Remote Equipment.



RYS. 2-0

1. Cut the bands holding the components together.
2. Remove the parts which are placed on the box. Next remove the parts from inside of the box. Remove the box from the pallet.
3. Plug the power cord, turn the main power switch to the ON position. Switch the key to the "M" position. Press the START button to start the blade motor for the moment. Then stop the motor and check if the motor rotations are in accordance with the arrow on the motor cover.



IMPORTANT! When starting the machine for the first time, check that main motor rotation direction is as indicated by the arrow located on the motor body (fan guard). If the rotation direction is incorrect, invert the phases in the phase inverter located in the power socket (electric box). Setting the phases in the phase inverter correctly will ensure

correct rotation directions of all sawmill motors.

4. Carefully raise the cutting head by about 20 cm.
5. Turn the key switch to the “0” position. Turn the main power switch to the OFF position and disconnect the power cord.
6. Using a forklift truck with lifting capacity of at least 1000 kg, carefully lift the two bed sections from the pallet.
7. Plug the power cord again, turn the main power switch to the ON position. Switch the key to the “M” position and lower the cutting head completely. Then turn off power and disconnect the power cord.
8. Lift the last bed section with the saw head.



WARNING! When lifting the bed sections, especially the bed section with the saw head, use extreme care and keep all persons at a safe distance. Failure to do so may result in serious injury or death.



IMPORTANT! When the saw head with bed section is taken off the pallet, remove two short legs and mount them as shown on the picture, [See Section 2.3](#).

2.3 Bed Frame Assembly



IMPORTANT! With all screw joints without split lock washer or lock nylon nut, use the "LOCTITE 243" (blue, of average durability, for screw joints).

1. Mount the legs to each bed section as shown below.

See Figure 2-1. Non-adjustable legs are shown below.

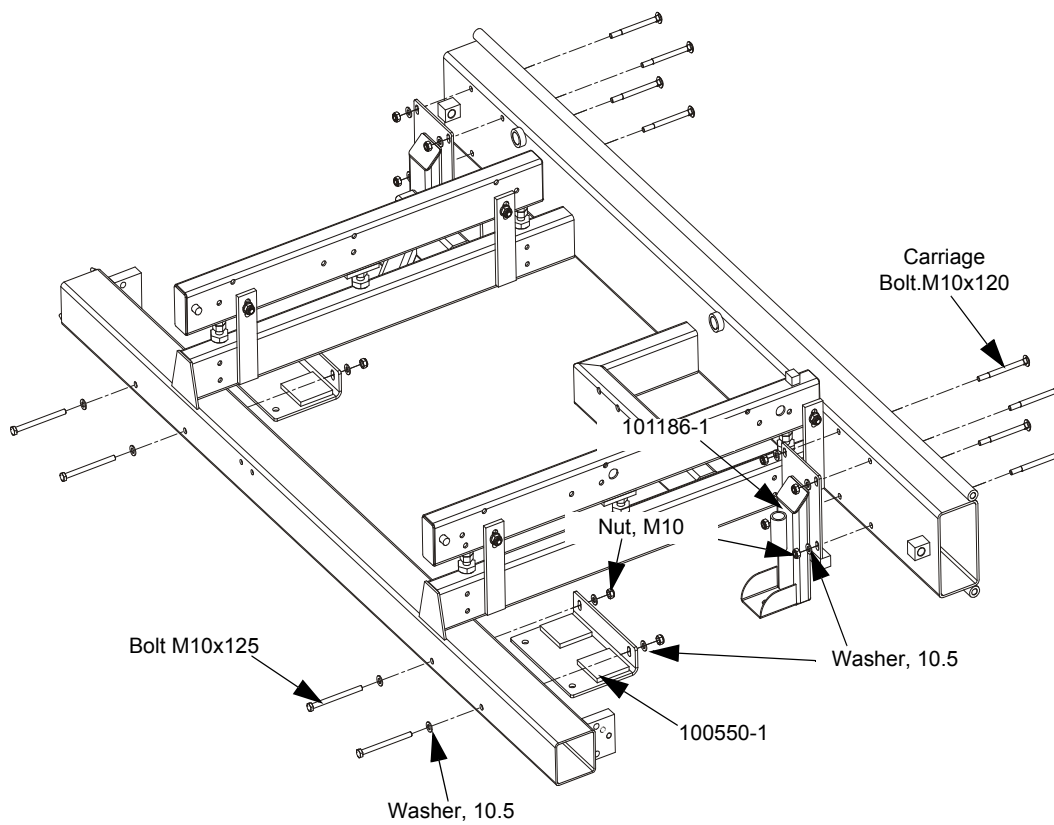

FIG. 2-1

See Figure 2-2. Adjustable legs are shown below.

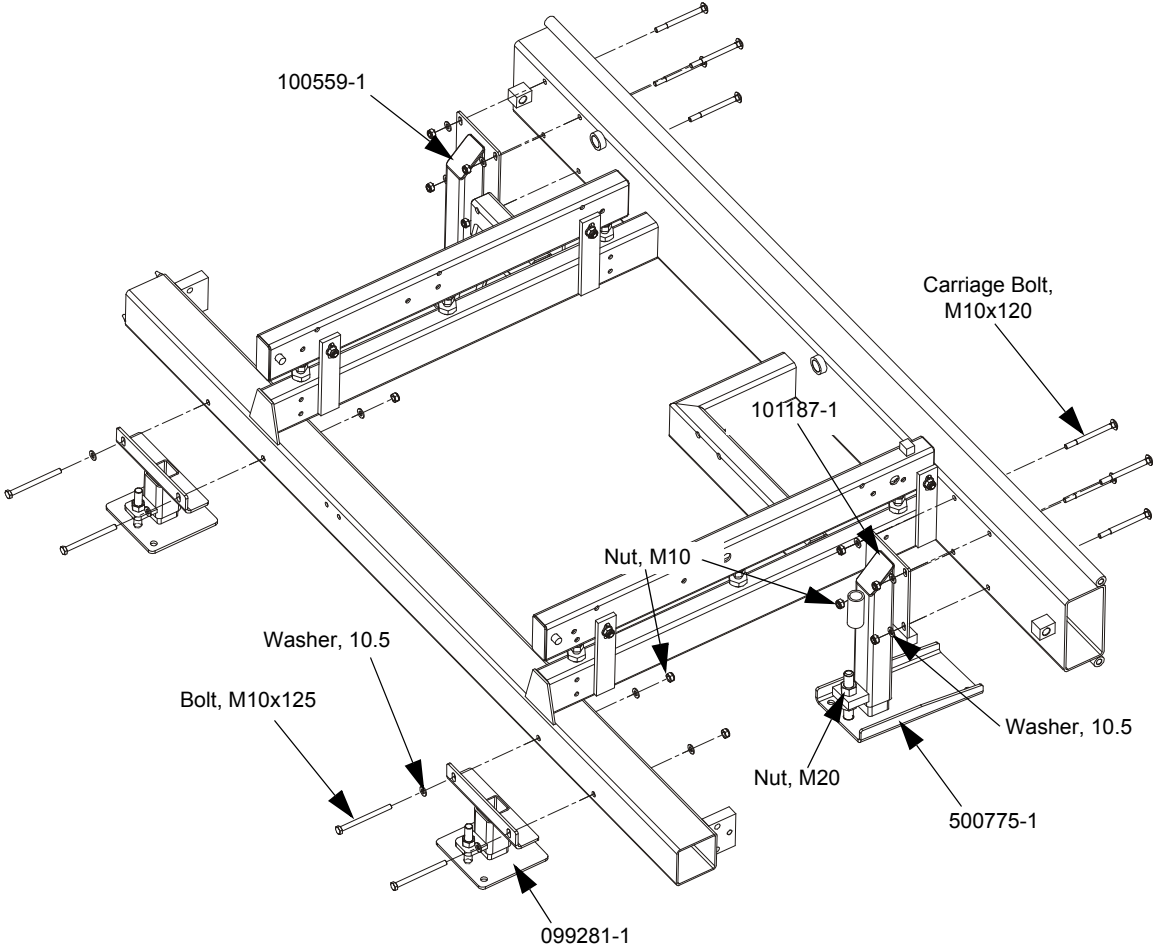

FIG. 2-2

2. Mount the bed segments together.

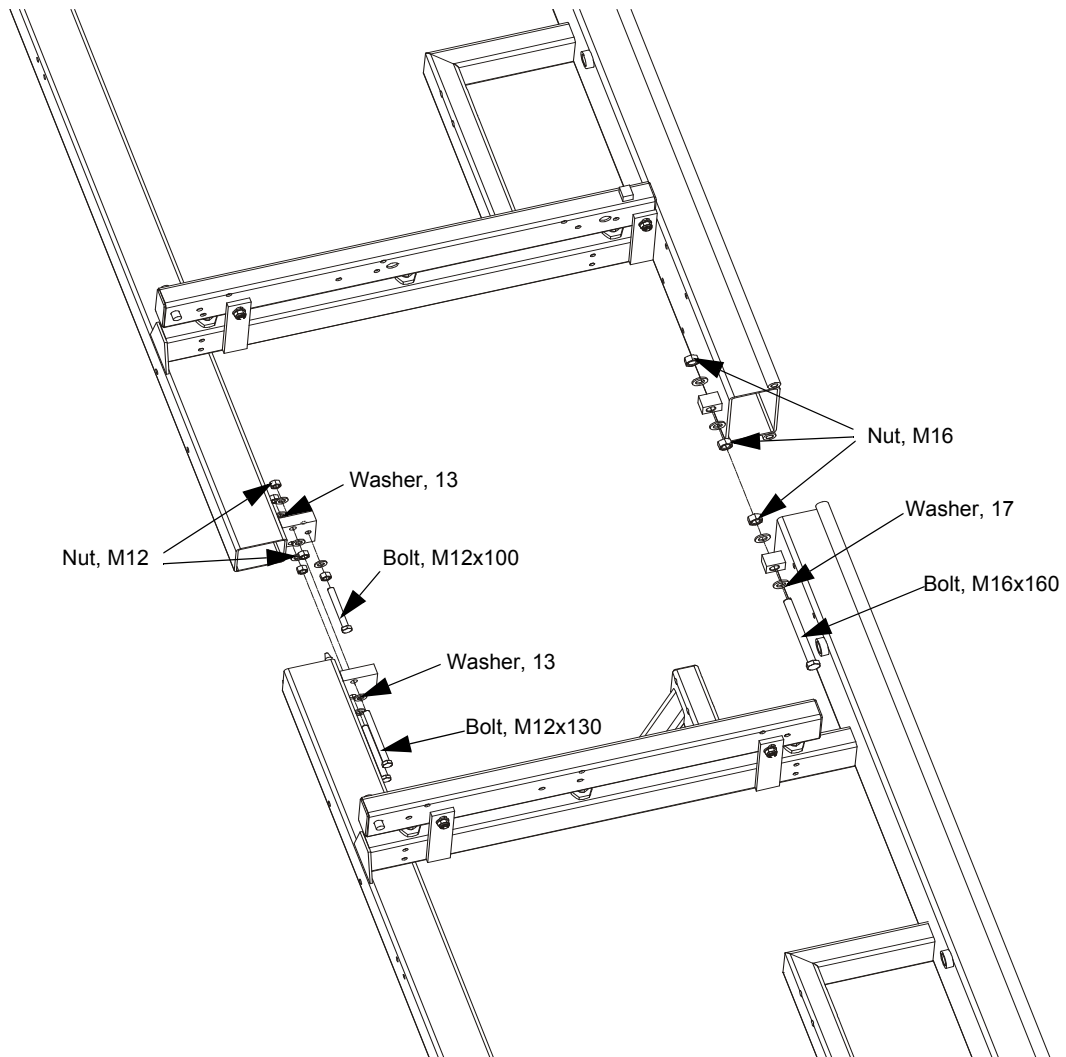

FIG. 2-3

3. Align the bed sections.

Put the flat bar against the upper track rail and check if it touches the rail along its entire length. If there is a gap in the middle of the bar, you need to screw in the adjustment bolt and tighten the mounting bolt. If there is a gap at one end of the bar, you need to loosen the mounting bolt and unscrew the adjustment bolt.

Repeat the above procedure on each segment connection (depending on the number of sections used).

See Figure 2-4.

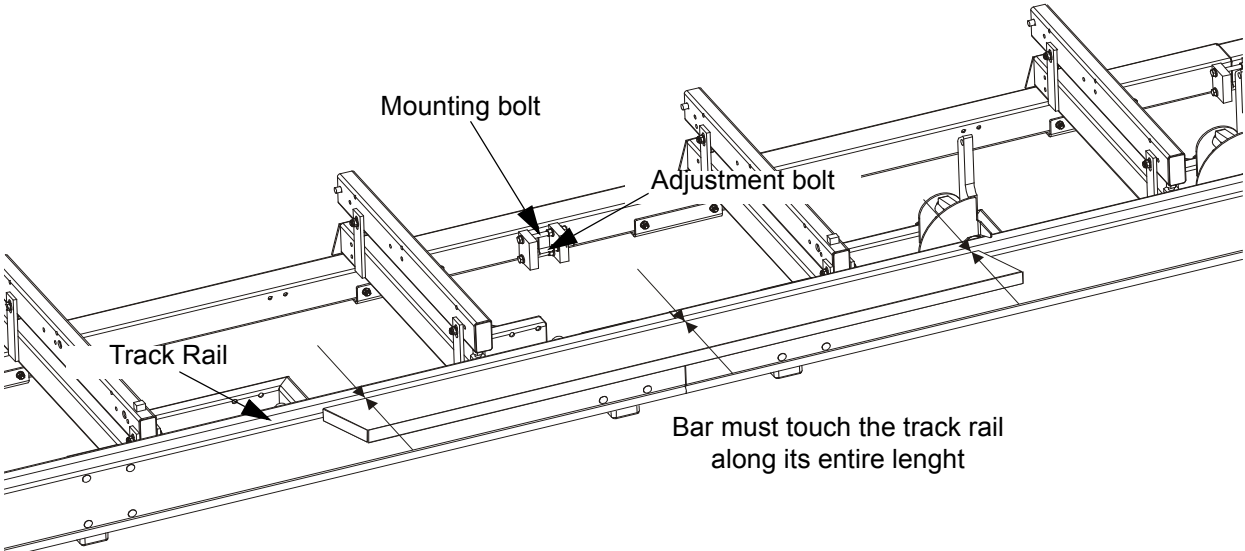

FIG. 2-4

Next place the bar on the top of the upper track rail. The bar must touch the rail along its entire length. If there is a gap in the middle of the bar or at its end, you need to put wedges under segment legs (frame with non-adjustable legs) or adjust the legs to raise the appropriate end of the segment (frame with adjustable legs).

See Figure 2-5.

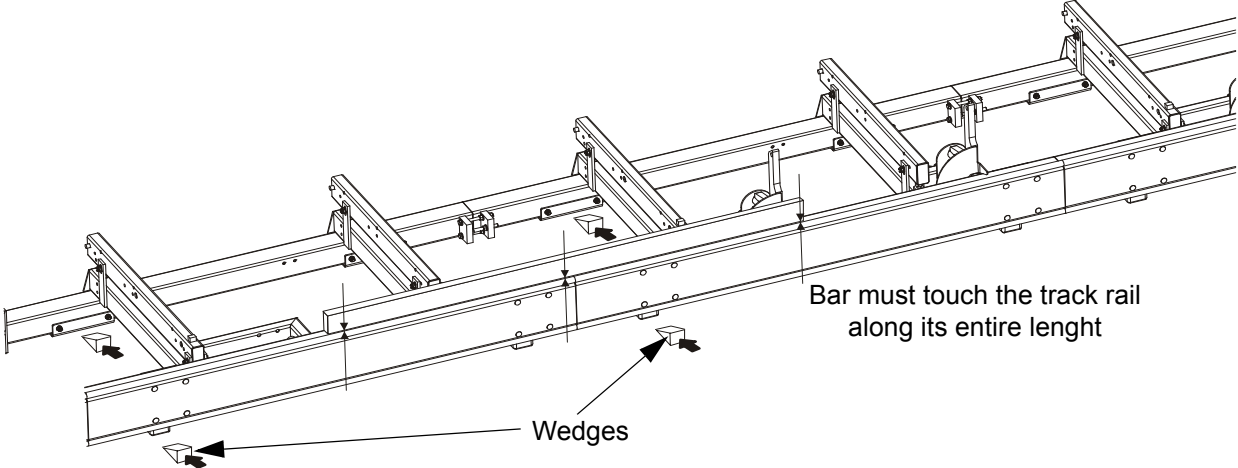

FIG. 2-5

2 SAWMILL ASSEMBLY

Bed Frame Assembly

4. Mount the bed extensions.

Mount the legs to the bed extensions. Next mount the main tube of the bed extension and the supporting tube together. Mount the complete bed extension to the sawmill frame.

See Figure 2-6.

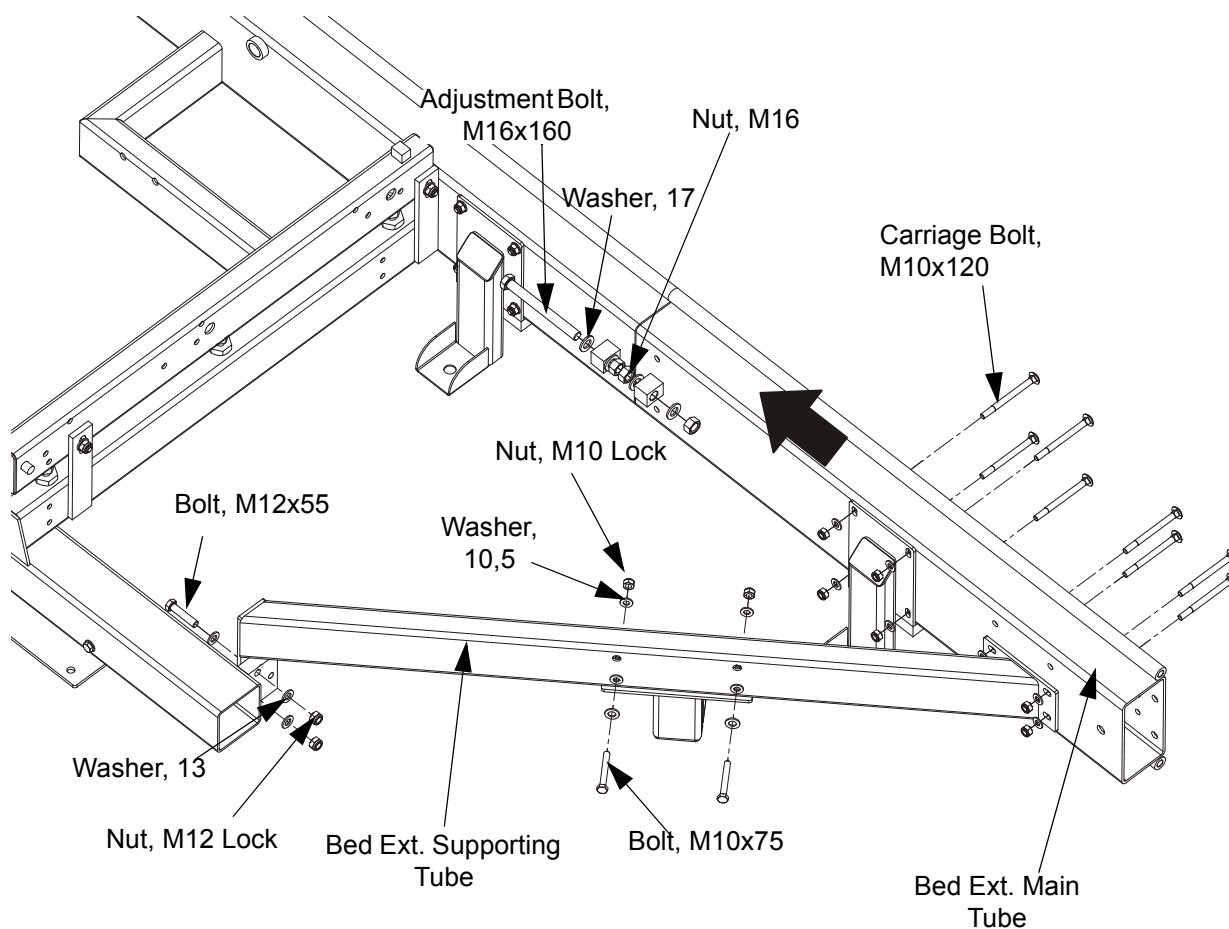

FIG. 2-6

5. Align the bed extension with the sawmill frame. Put the flat bar against the upper track rail and check if it touches the rail along its entire length. If there is a gap at one end of the bar, you need to tighten the adjusting bolt.

See Figure 2-7.

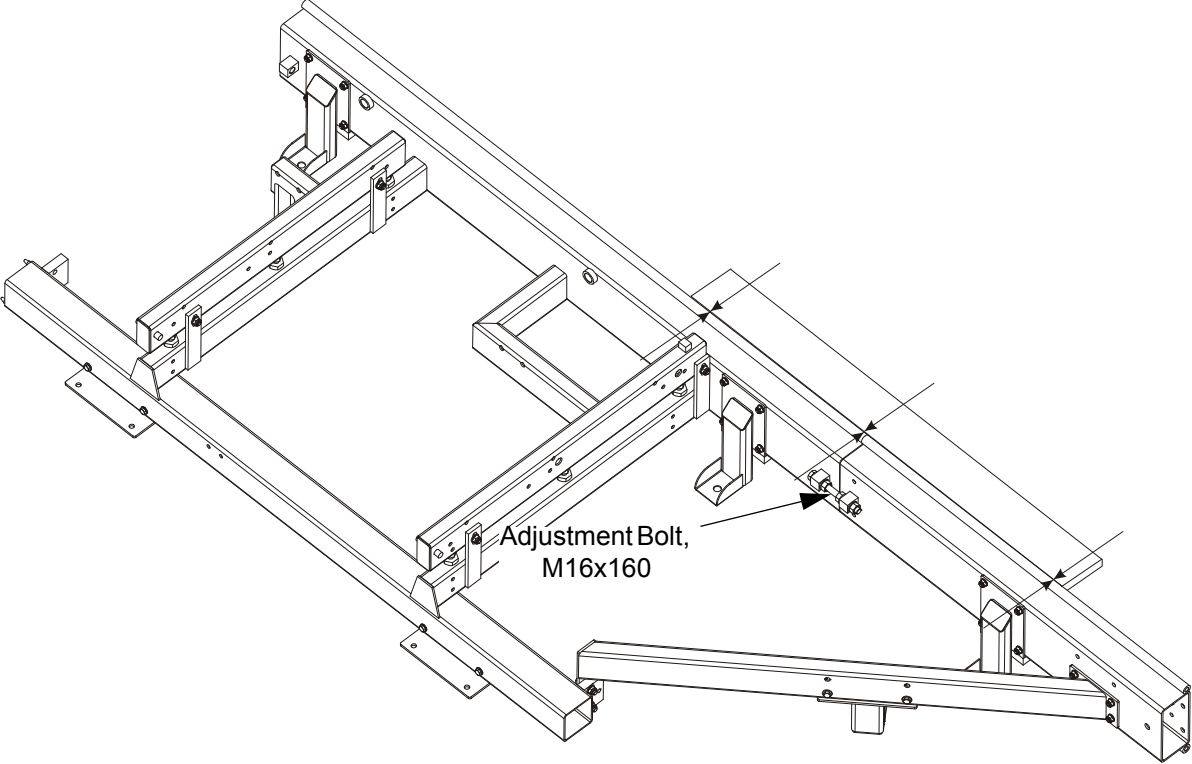

FIG. 2-7

6. Mount the saw head front bumper with the bracket and the main tube cover.

See Figure 2-8.

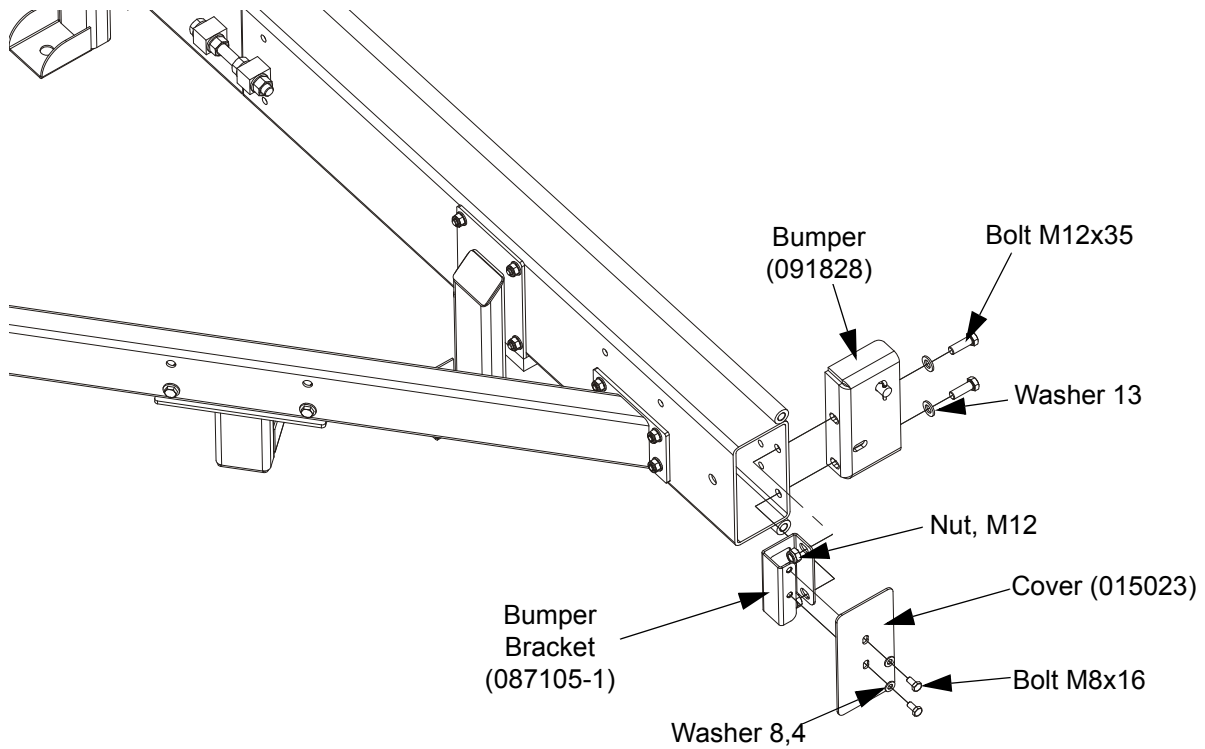

FIG. 2-8

7. Mount the rear bumper.

See Figure 2-9.

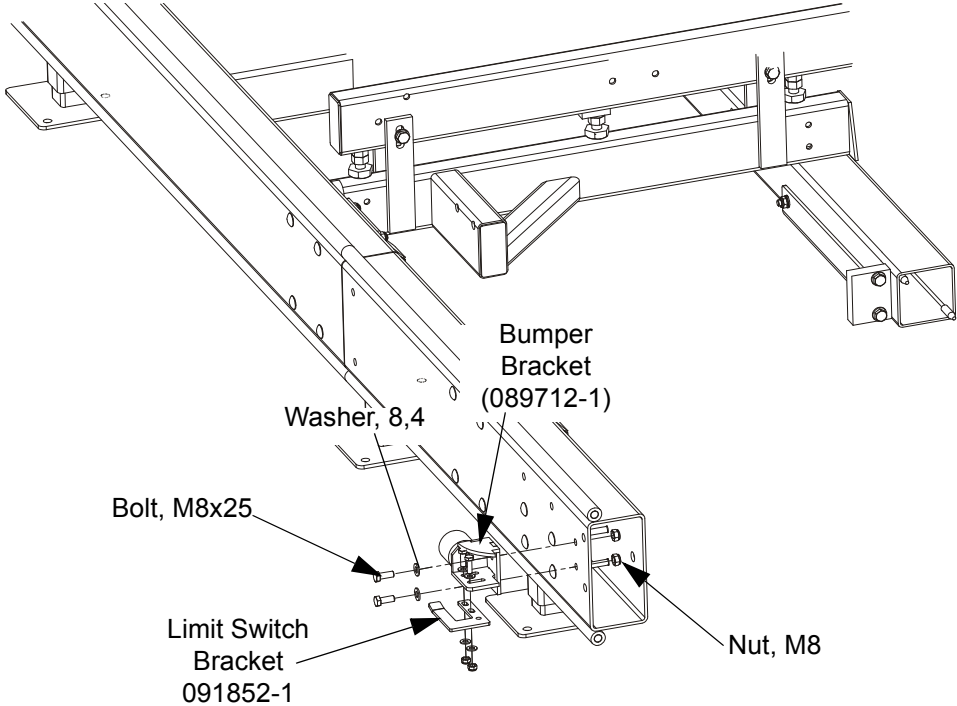

FIG. 2-9

8. Mount the side tube with the leg.

2 SAWMILL ASSEMBLY

Bed Frame Assembly

See Figure 2-10.

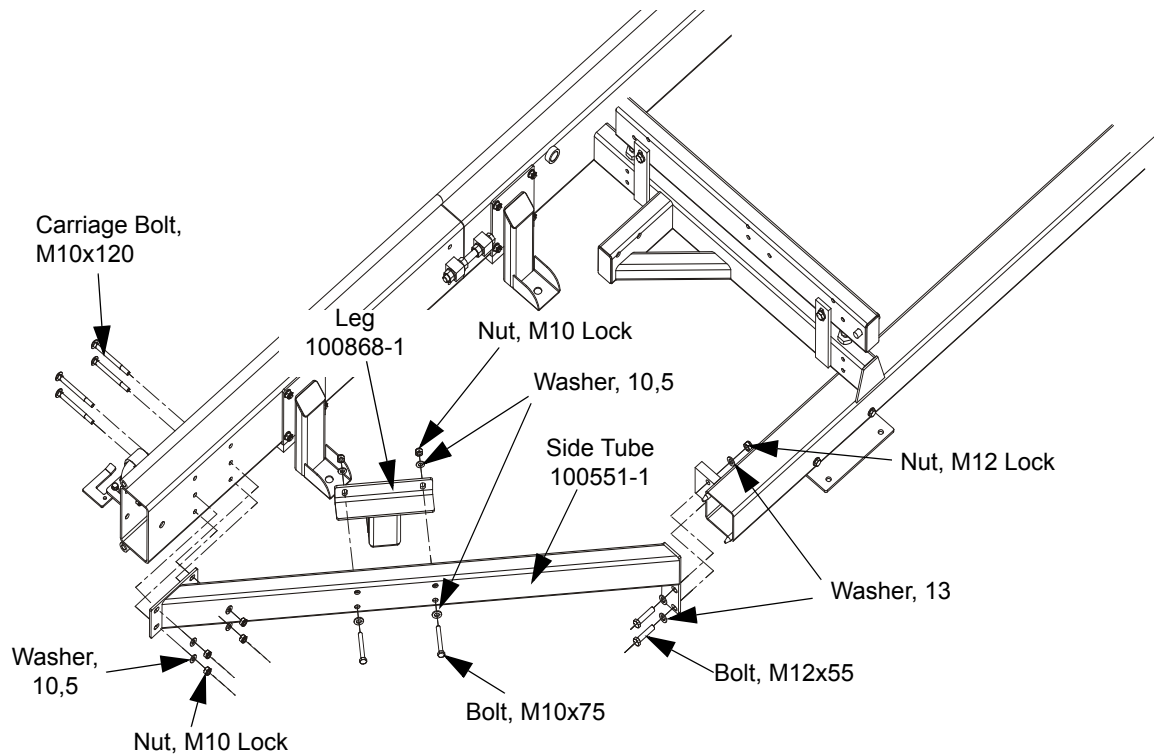

FIG. 2-10

9. Mount the log clamp.

See Figure 2-11.

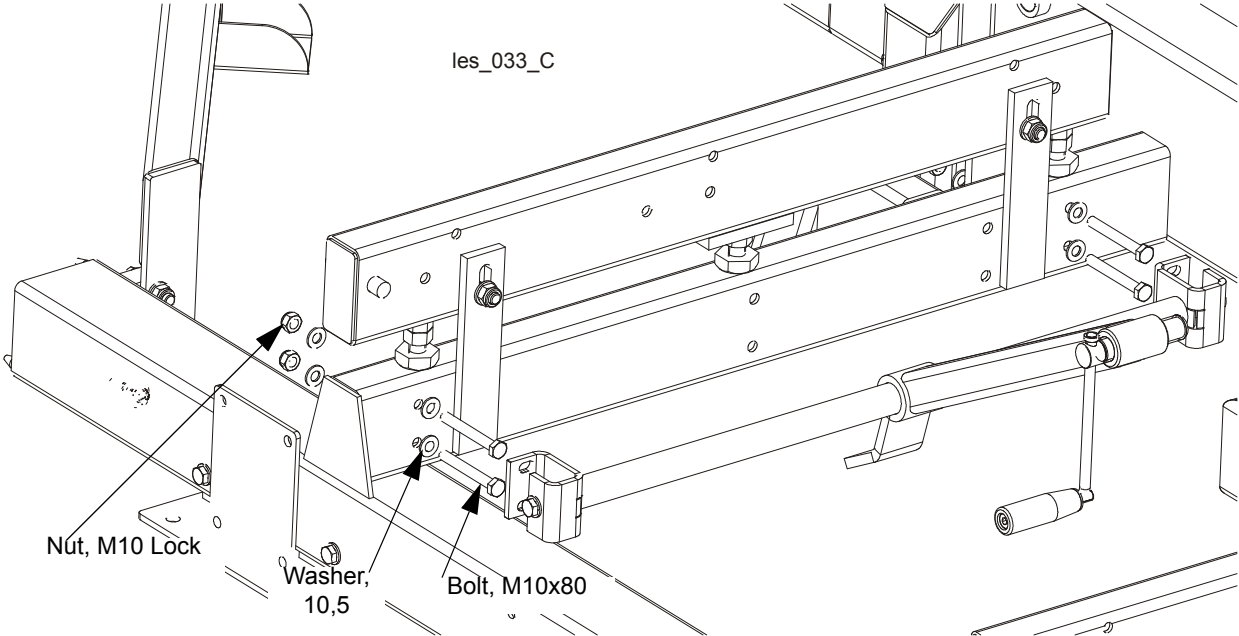

FIG. 2-11

10. Mount the sawdust chute.

See Figure 2-12.

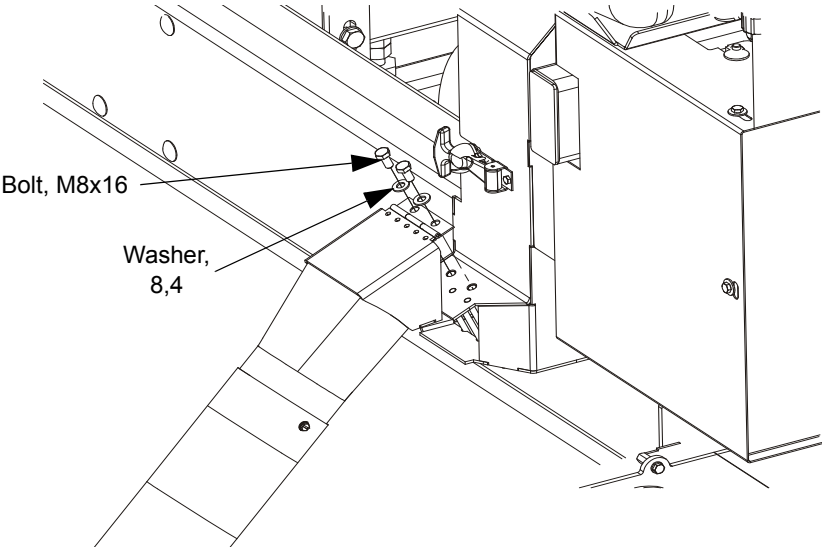

FIG. 2-12

11. Mount the power cord bracket.

See Figure 2-13.

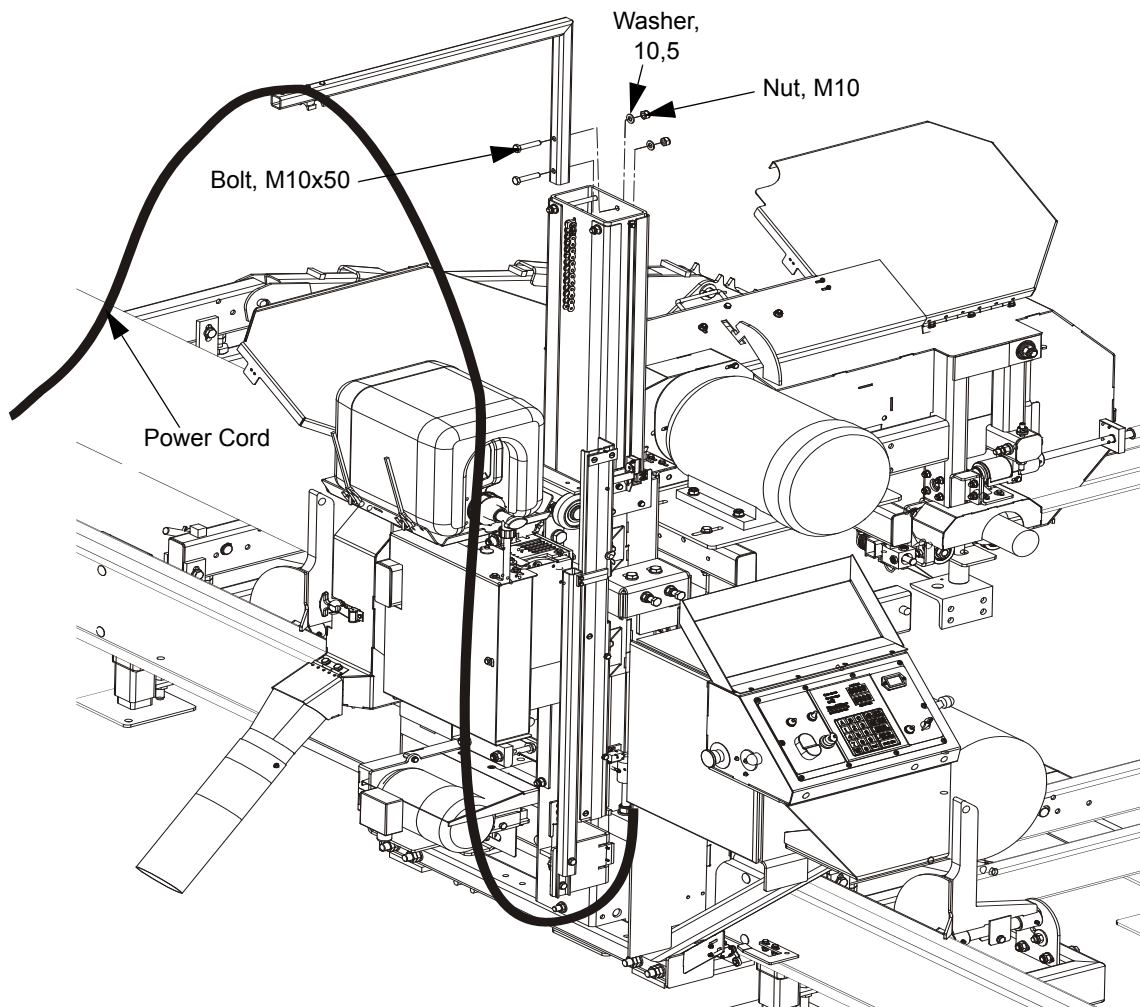

FIG. 2-13

12. Mount the log ramps (optional equipment).

See Figure 2-14.

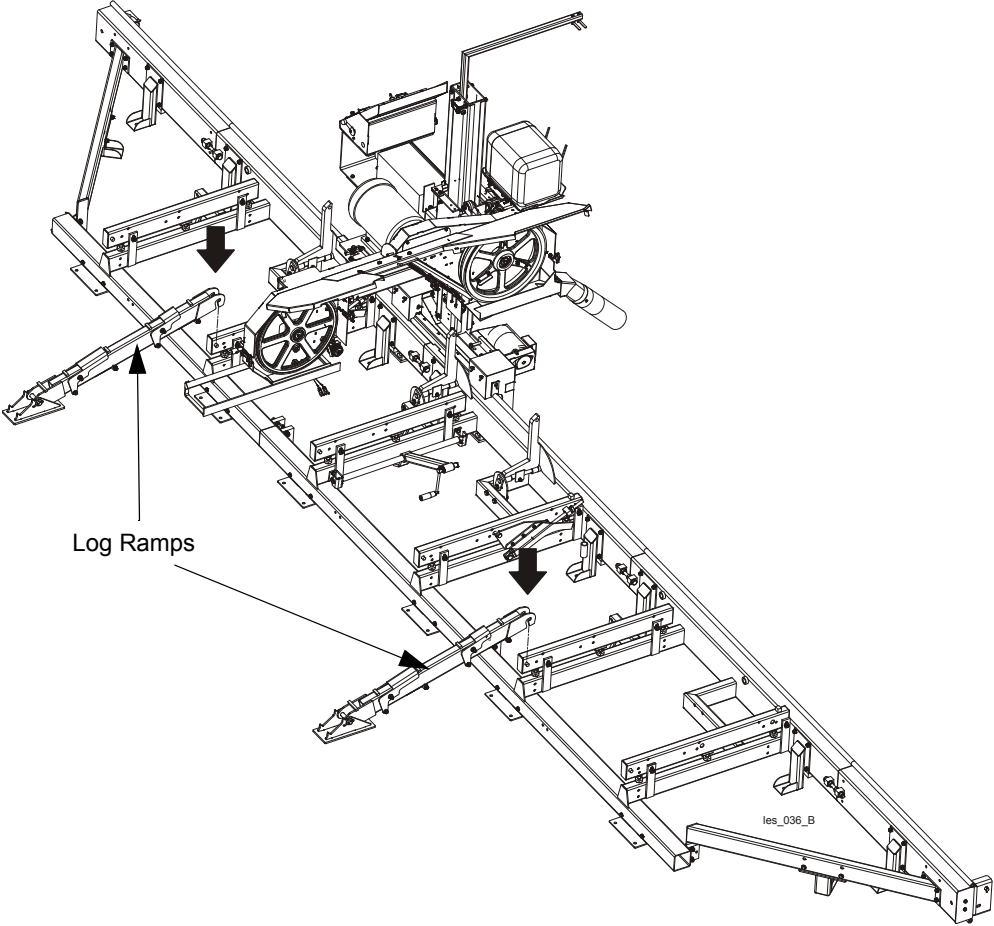

FIG. 2-14

SECTION 3 SETUP & OPERATION

3.1 Sawmill Setup



IMPORTANT! Before starting to use the sawmill you have to meet the following conditions:

- Set up the sawmill on firm and level ground.
- The sawmill can be operated with the sawdust collection system only.
- The sawmill can be operated under roof only.
- The sawmill can be operated in temperature range from -15° C to 40° C only.
- Illuminance at operator's position must be 300lx.
- Operator's working places are shown on the picture below

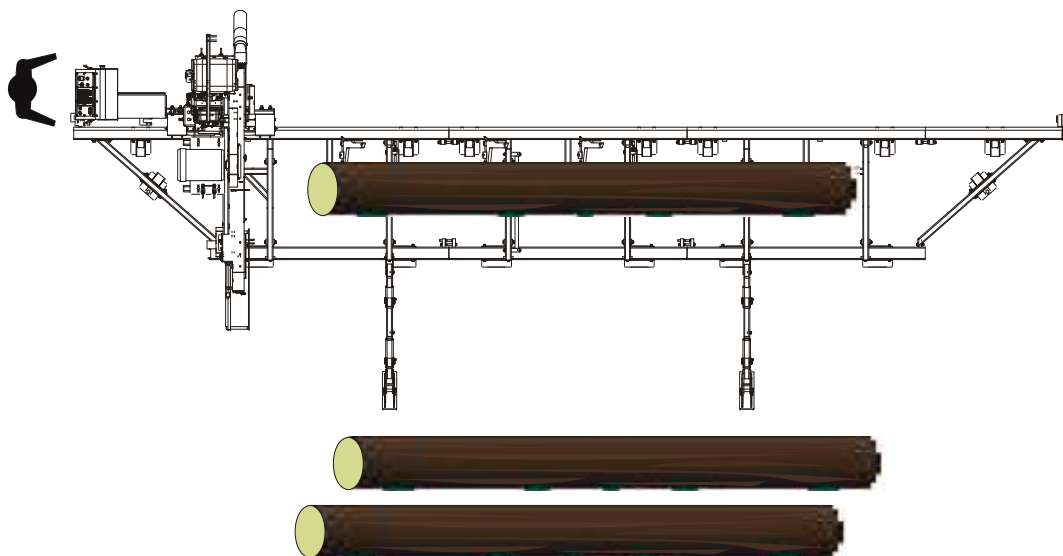

- Have a qualified electrician install the power supply (according to EN 60204 Standard). The power supply must meet the specifications given in the table below.

3-Phase Volts	Fuse disconnect	Suggested Wire Size
400 VAC	40 A	6 mm ² up to 15 m long

TABLE 3-1



IMPORTANT! When starting the machine for the first time, check that main motor rotation direction is as indicated by the arrow located on the motor body (fan guard). If the rotation direction is incorrect, invert the phases in the phase inverter in the power socket (electric box). Setting the phases in the phase inverter correctly will ensure correct rotation directions of all sawmill motors.

3.1.1 *Setting up sawmills equipped with non-adjustable legs*

Set up the mill on firm and level footing. Fasten the mill to the floor to prevent any creep after prolonged use. A cement pad with 5/8" (16 mm) diameter anchor bolts is recommended. The cement pad should be rated to support 6350 lbs./sq.ft. (31 T/m²) at each sawmill foot position.



WARNING! Do not operate a sawmill without the feet securely fastened to the floor.

3

SETUP & OPERATION

Setting up sawmills equipped with non-adjustable legs

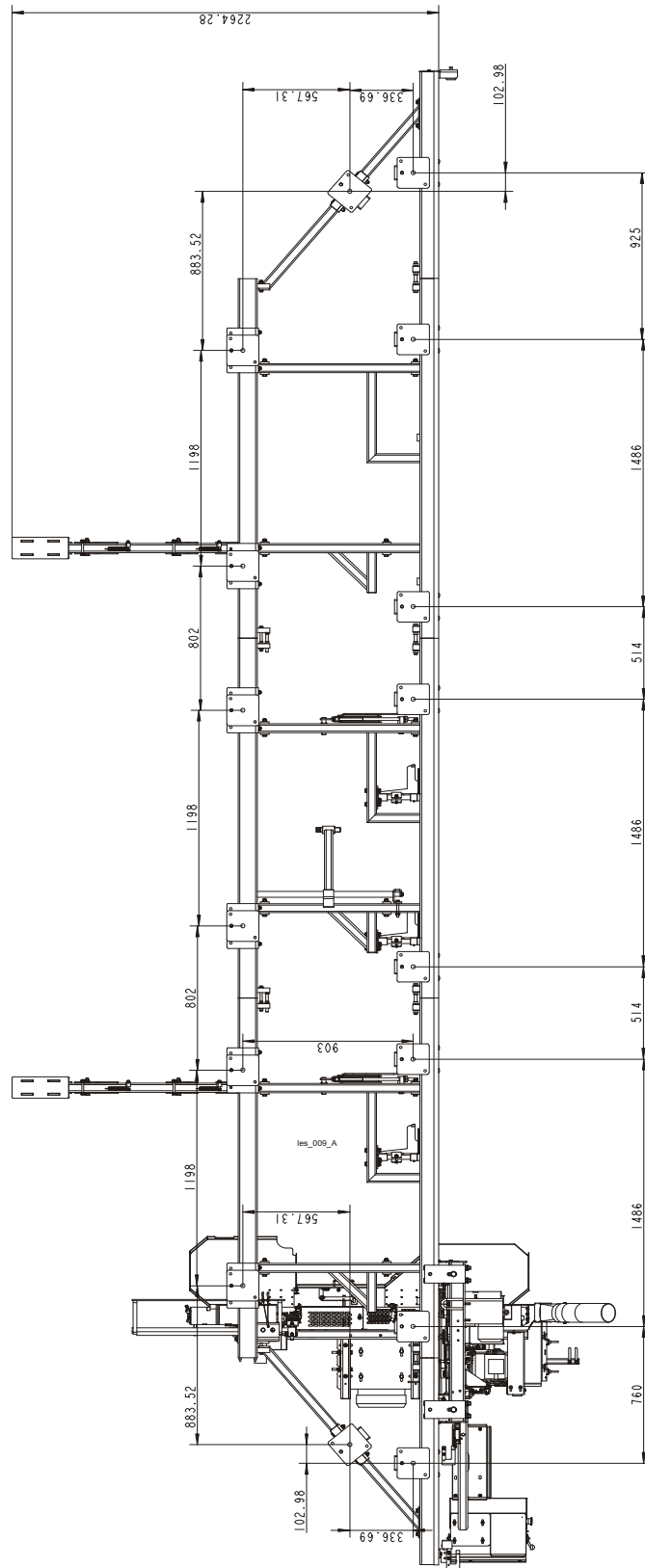

FIG. 3-1

3.1.2 Setting up sawmills equipped with outrigger legs



WARNING! If it is necessary to set up the sawmill on ground with more than 3° incline, dig out areas for outrigger legs to prevent the sawmill from tipping over.

13. After mounting the segments together, level the sawmill frame using the outrigger legs.

See Figure 3-2.

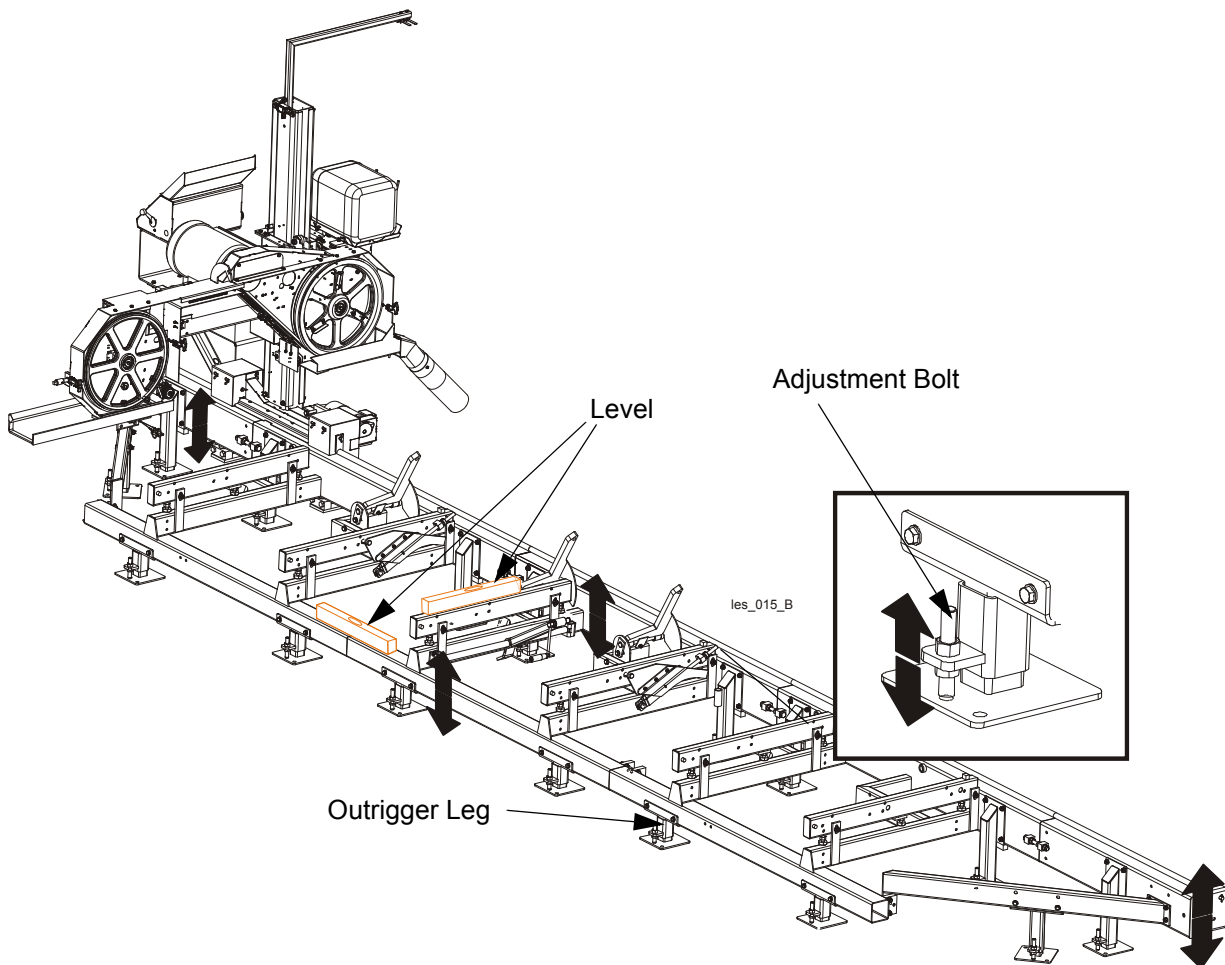

FIG. 3-2. OUTRIGGER ADJUSTMENT

See Figure 3-3.

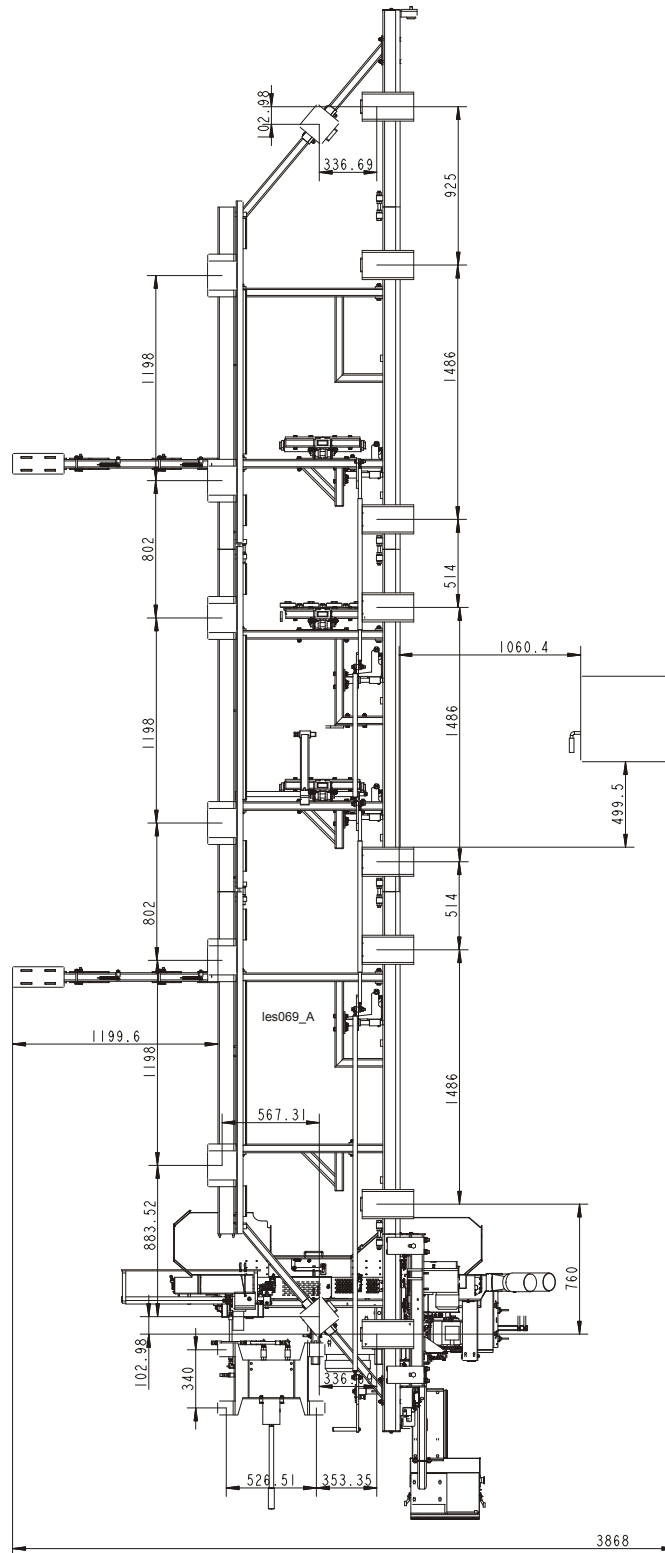

FIG. 3-3. OUTRIGGER PLACEMENT (H1, H2, H3 HYDRAULIC)



CAUTION! When setting up the sawmill on boggy terrain (such as deep mud or sand), place a board or a metal plate under each outrigger leg to prevent the legs from sinking.

NOTE: Make sure the unit is level before securing. The sawmill mast should not be tilted from the vertical more than 3° towards the loading ramps. The mast should not be tilted in the opposite direction.

See Figure 3-4 Sawmill Mast Tilt

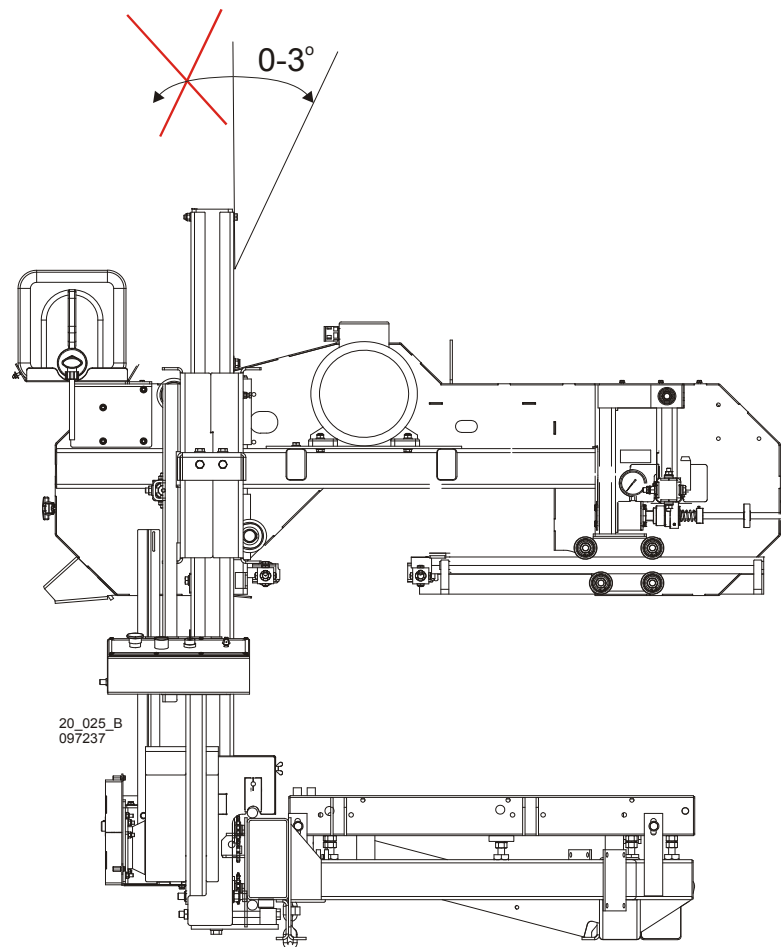

FIG. 3-4

14. Unhook the carriage safety chain, located at the bottom of the vertical mast.
15. Use the up/down crank or the up/down switch to raise the cutting head from the carriage rest pin. Swing the rest pin below bed level.
16. Use the power feed switch to move the cutting head toward the front end of the mill. Raise the two side supports that will prevent a log from falling off the side of the mill when loaded.

See Figure 3-5.

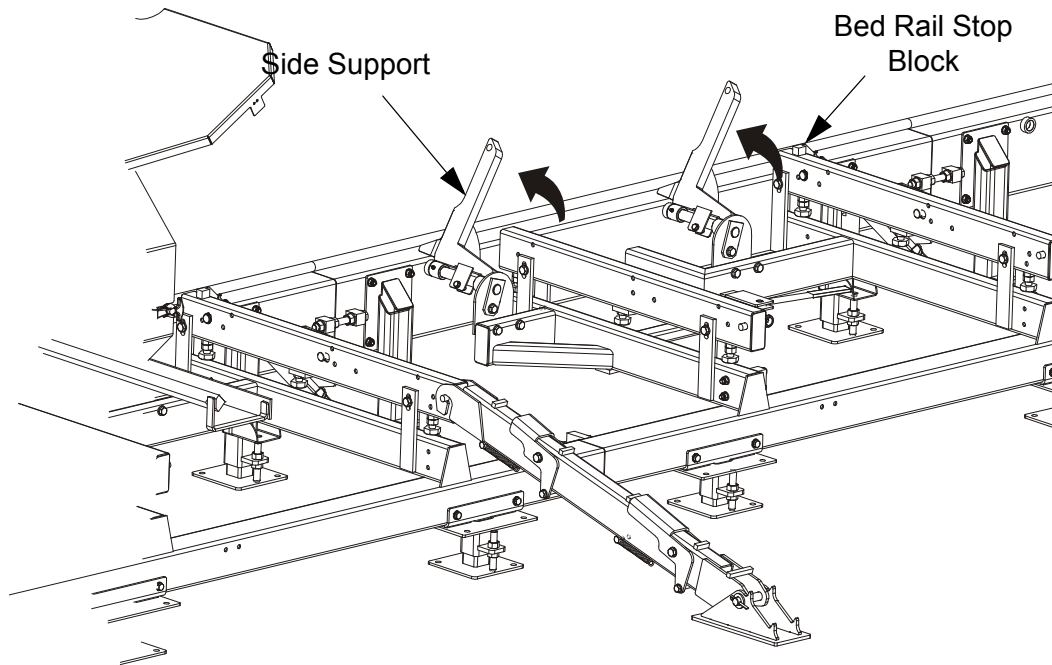

FIG. 3-5

3.1.3 *Sawmills with cable guide*

See Figure 3-6. The figure below shows setup of the sawmill, the control box and the cable guide columns.

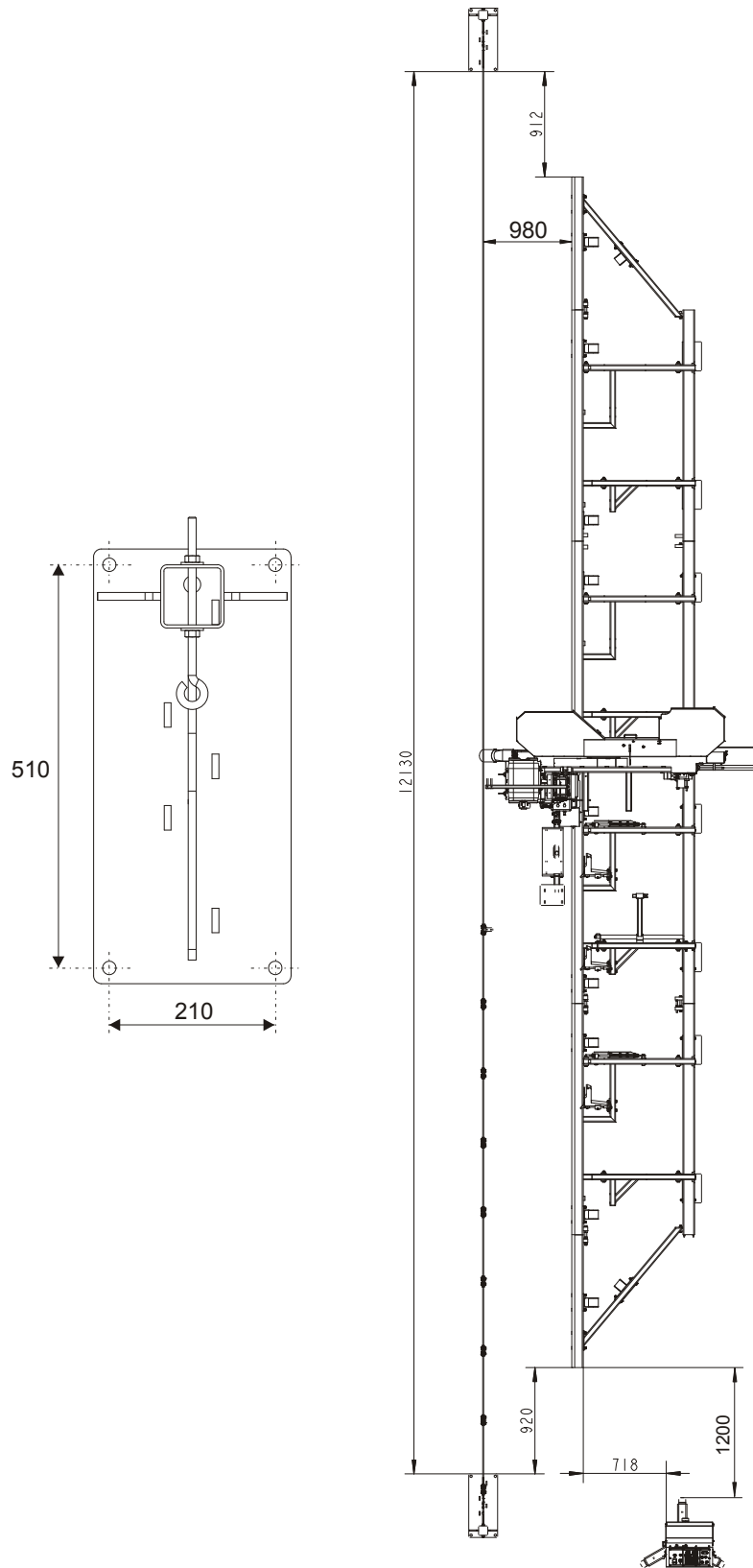

FIG. 3-6

3

SETUP & OPERATION

Sawmills with cable guide

See Figure 3-7. The electrical wires should be installed on the cable guide as shown below.

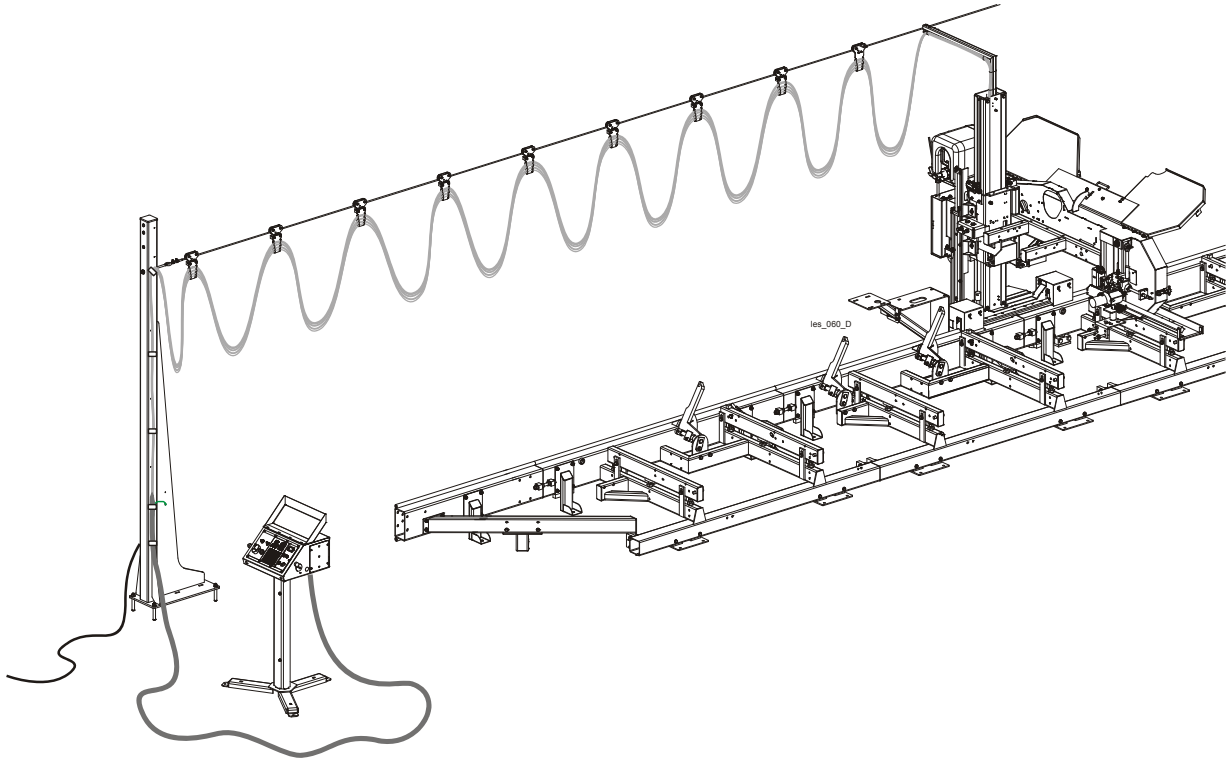

FIG. 3-7

See Figure 3-8. The figure below shows how the electrical wires should be installed on the roller hangers.

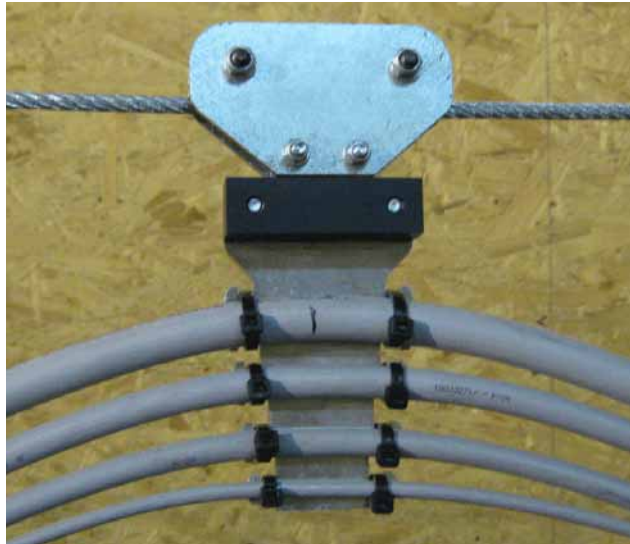



FIG. 3-8

 **CAUTION!** Be sure the larger diameter cables are mounted to the upper brackets of the roller hangers, and the smaller diameter cables are mounted to the lower brackets of the hangers.

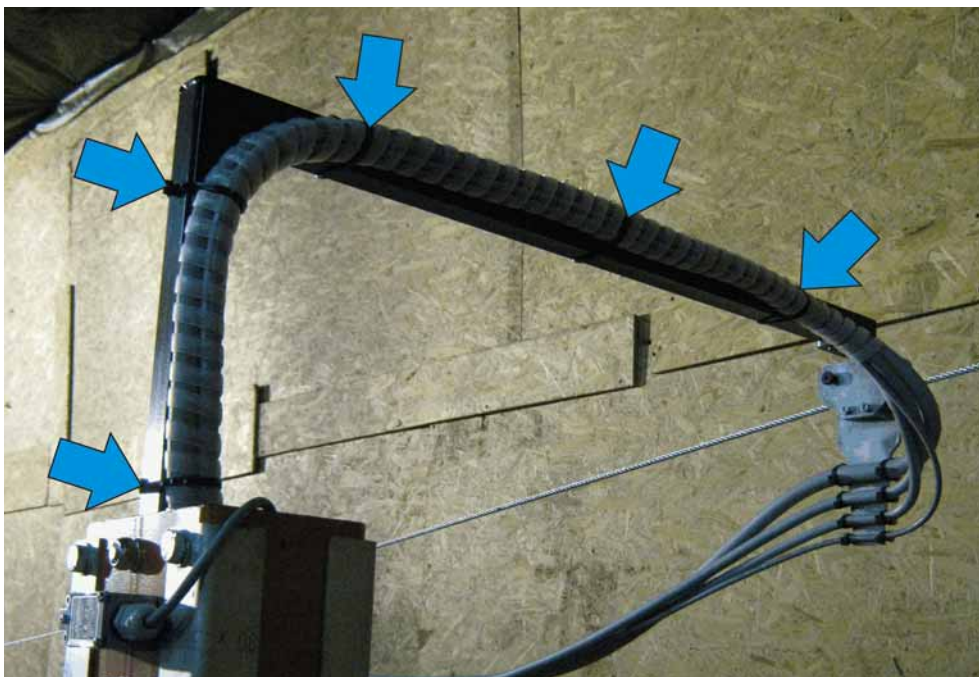

FIG. 3-9

3.2 Middle Track Cover

Before operating the sawmill do as follows:

1. Clean the upper and lower rails to remove any sawdust and rust preventive.
2. Unbolt and remove the middle track cover from its storage position.
3. Soak the felt wiper with Dexron III transmission fluid, 10W30 motor oil or 3-in-1 turbine oil.
4. Install the middle track cover so it fits against the rail and secure with two thumb screws.

See Figure 3-10.

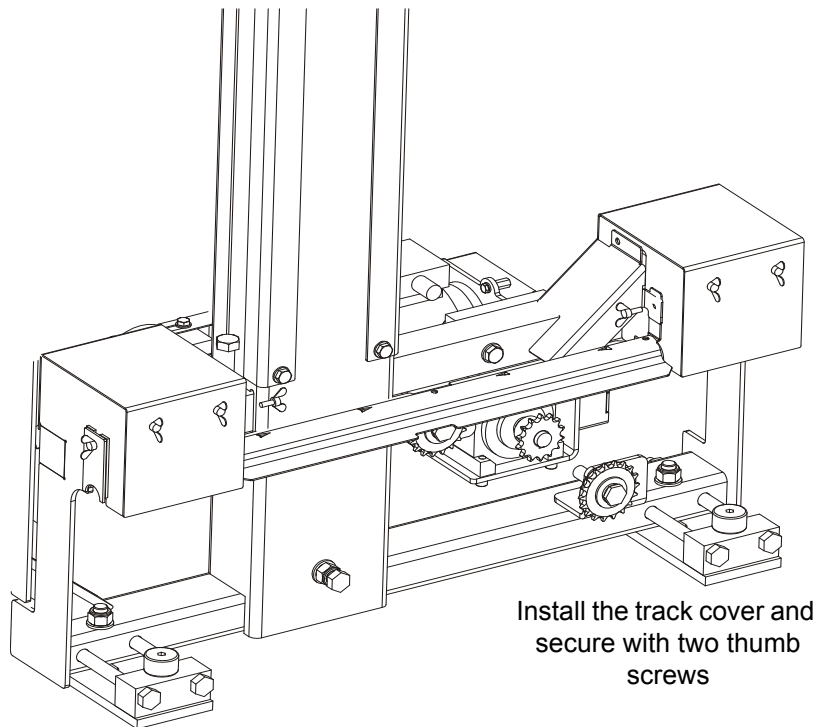

FIG. 3-10



CAUTION! Install the track cover so that it lightly touches the track rail. If the wiper presses too firmly against the rail, it can cause the power feed to bind.

3.3 Replacing The Blade



DANGER! Always shut off the sawmill motor before changing the blade. Failure to do so may result in serious injury.



WARNING! Always wear gloves and eye protection whenever handling bandsaw blades. Changing blades is safest when done by one person! Keep all other persons away from work area when changing blades. Failure to do so may result in serious injury.

Raise the blade housing cover. Turn the blade tension handle to release the blade tension until the wheel is pulled in and the blade is lying loose in the blade housing. Lift the blade out of the blade housing.

When installing a blade, make sure the teeth are pointing the correct direction. The teeth should be pointing toward the operator side of the mill when you are looking at the blade below the blade guides. Install the blade so it is lying around the wheels.

Position 1 1/4" wide blades on the wheels so the gullet is 3.0 mm (\pm 1.0 mm) out from the front edge of the wheel.

Close the blade housing cover.

Next, turn the tension handle until the blade is tensioned correctly.



CAUTION! Should you need to adjust the blade position, never grab the wheel arms to spin the idle-side blade wheel as your fingers can get pinched.

3 SETUP & OPERATION

Tensioning The Blade

3.4 Tensioning The Blade

See Figure 3-11. Turn the blade tension handle clockwise until the tension gauge indicates the recommended tension. Check the blade tension occasionally when adjusting the cant control or while cutting. As the blade and belts heat up and stretch, the blade tension will change. Also, ambient temperature changes can cause tension to change.

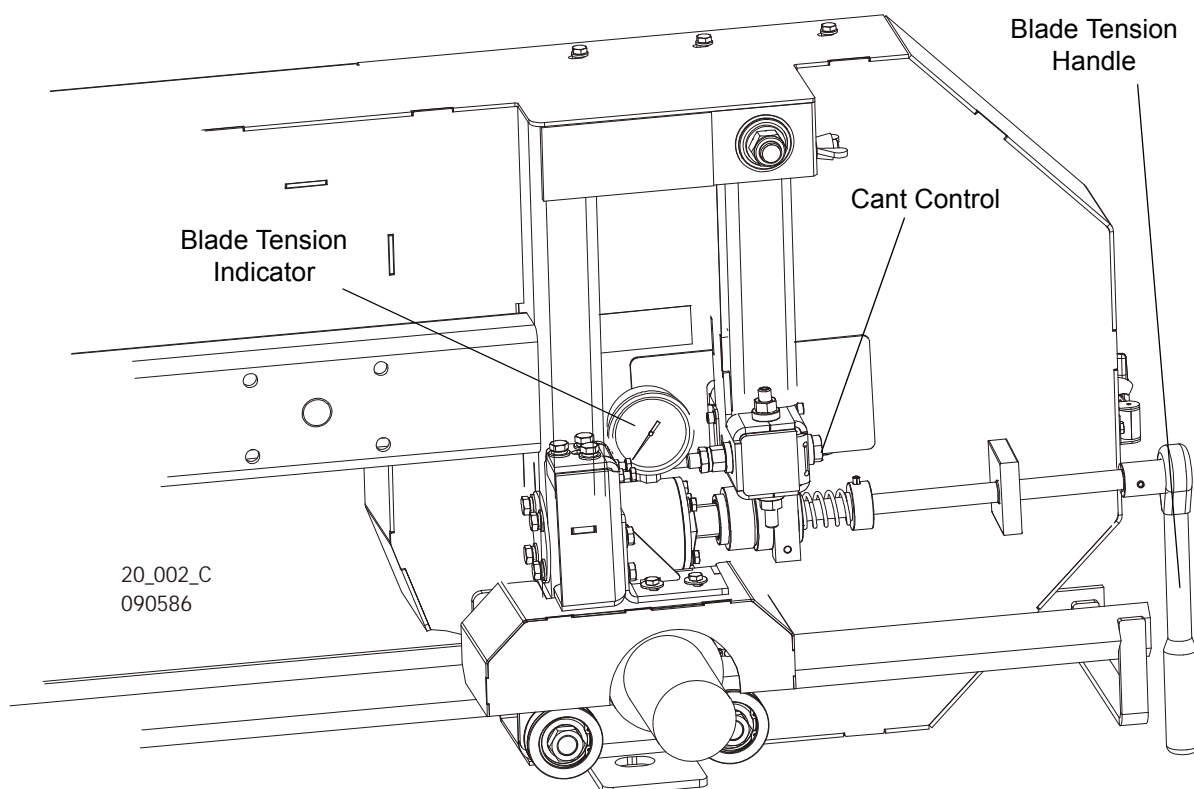

FIG. 3-11



CAUTION! Release the blade tension when the mill is not in use.

See Table 3-12. The recommended tension for different blades is shown below.

Blade Type	Blade Dimensions		Tension range	
	Width (mm)	Height (mm)	PSI	Bar
275	1.07	32	1015-1088	70-75
375	1.14	32	1088-1160	75-80
2735	1.07	35	1160-1233	80-85

TABLE 3-12

3.5 Tracking The Blade

1. Open the blade housing cover.
2. Turn the key switch to the "H" position.



3. Manually spin one of the blade wheels until the blade positions itself on the blade wheels.
4. Check if the blade is properly positioned on the blade wheels.

See Figure 3-13. Position 1 1/4" wide blade on the wheels so the gullet is 3.0 mm (0.12") \pm 1.0 mm (0.04") out from the front edge of the wheel.

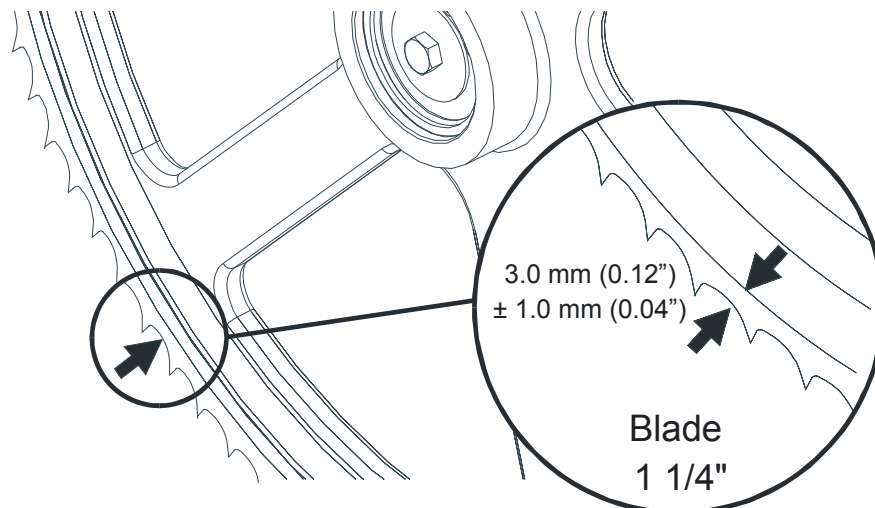

FIG. 3-13

5. Use the cant adjustment bolt, shown in **Figure 3-11** to adjust where the blade travels on the blade wheels.

To move the blade out on the blade wheel, turn the cant adjustment bolt clockwise.
To move the blade in on the blade wheel, turn the bolt counterclockwise.

6. After adjusting the tilt of the blade wheels with the cant adjustment bolt, tension the blade properly.
7. Close the blade housing cover.

3 SETUP & OPERATION

Tracking The Blade



DANGER! Make sure all guards and covers are in place and secured before operating or towing the sawmill. Failure to do so may result in serious injury. Be sure the blade housing cover is in place and secured.

DANGER! After aligning the blade on the wheels, always check the blade guide spacing and location. (See Section 5 for more information.)

3.6 Starting The Motor (AC sawmill)

See the appropriate manual supplied with your specific motor configuration for starting and operating instructions.



IMPORTANT! For safe operation of the sawmill, one person is sufficient, however in case of manual collection of sawn material, at least two persons should be assigned to these activities in order not to exceed the manual lifting standard.



CAUTION! Before starting the sawmill, the operator must warn all persons who are nearby of the intention of starting the machine.



IMPORTANT! The sawmill should be operated only by a qualified person of age, being in good state of health confirmed by a medical certificate.

IMPORTANT! When starting the machine for the first time, check that main motor rotation direction is as indicated by the arrow located on the motor body (fan guard). If the rotation direction is incorrect, invert the phases in the phase inverter located in the power socket (electric box). Setting the phases in the phase inverter correctly will ensure correct rotation directions of all sawmill motors.



WARNING! Make sure all guards and covers are in place and secured before operating or towing the sawmill. Failure to do so may result in serious injury. Be sure the blade housing cover is in place and secured.

WARNING! Do not start the motor when the clutch/brake lever is in the engaged position. Always be sure the blade is disengaged and all persons are out of the path of the blade before starting the motor. Failure to do so will result in serious injury.



WARNING! Always wear eye, ear, respiration and foot protection when operating the machine. Secure all loose clothing and jewelry before operating the sawmill. Failure to do so may result in serious injury.

WARNING! Always connect and start the dust extraction system before starting the machine, [See Section 1.13](#).



CAUTION! If at any time you need to immediately stop the blade motor, press the emergency stop button located on the control box.

Before starting the sawmill at a new location, at least once a year or after every repair have a qualified electrician (having appropriate measurement qualifications) check the insulation resistance and electric shock protection of the electrical system.

The electric box should be protected against dust and moisture. Regularly disconnect power supply and clean the inside of the electric box of dust, sawdust, etc. Do not operate or leave the sawmill with the electric box door open.



DANGER! Hazardous voltage inside the electric box (even if disconnected with the main disconnect switch) and at the motor can cause shock, burns, or death. Always disconnect power supply before servicing!

3.7 Loading, Turning, And Clamping Logs

3.7.1 Sawmills equipped with MH (Manual Hydraulics)



CAUTION! Make sure the clamps and the toe boards are below bed level before loading a log onto the bed. Also, be sure the cutting head is moved far enough forward so the log does not hit it.

To Load Logs:

1. Raise the side supports.
2. Place the log at the foot of the loading ramps. Using a cant hook, roll the log onto the sawmill bed.

NOTE: Logs also may be loaded onto the mill with a forklift or other equipment specifically designed for that purpose.

To Turn Logs:

1. Disengage the clamp.
2. Use the cant hook to rotate the log on the sawmill bed.
3. Clamp the log.

To Clamp Logs:

1. Position the clamp against the log.
2. Move the clamp down far enough so that it is below your first few cuts. Turn the clamp screws in so they move the log firmly against the side supports.

See Figure 3-14.

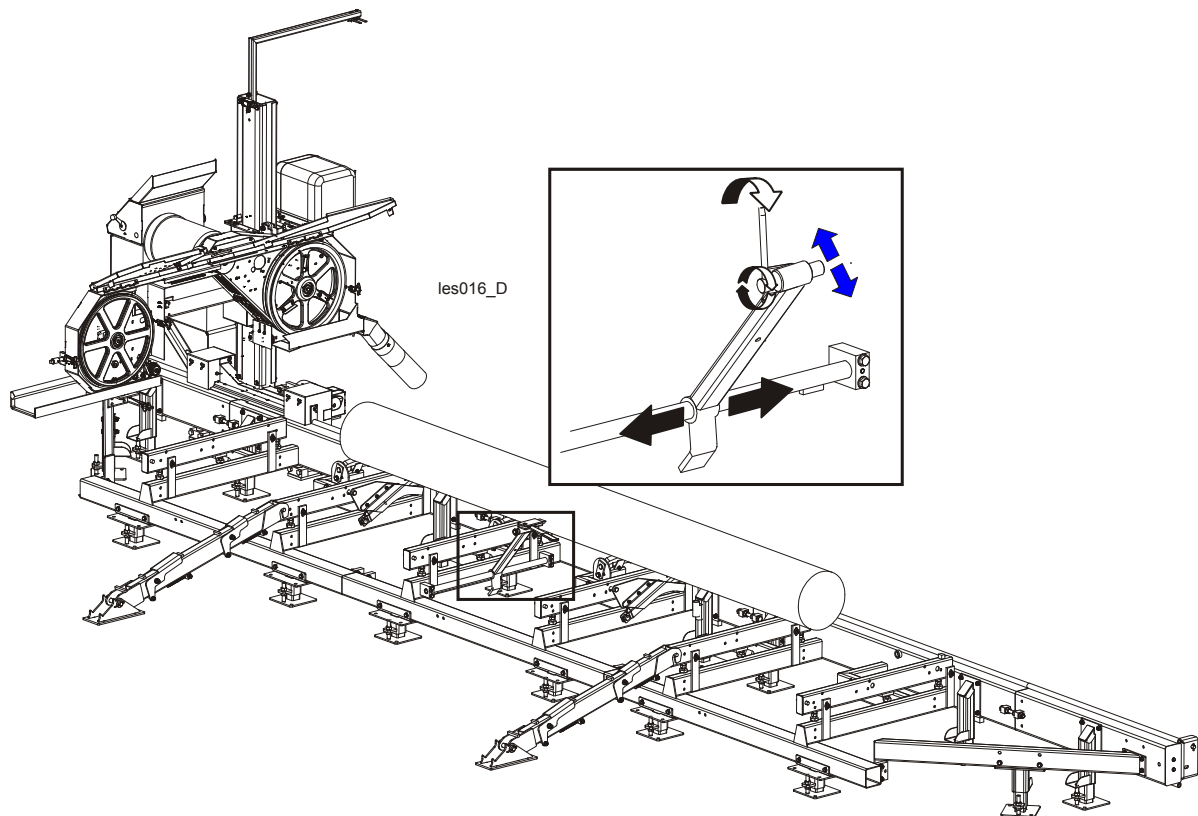

FIG. 3-14

3. Be sure to leave crank in the bottom position to avoid damage to the blade.

See Figure 3-2.

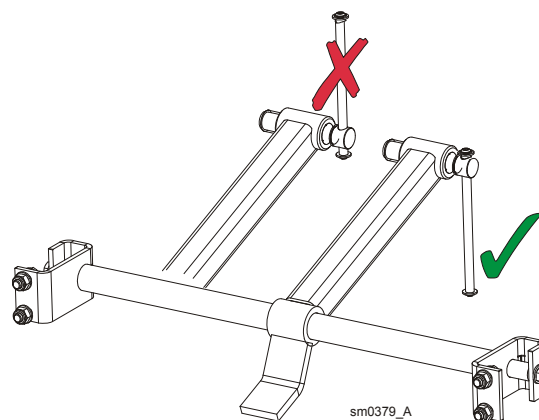

FIG. 3-2

4. Make sure the side supports are positioned low enough for the blade to pass over them. If they are not, back the clamp off slightly and push the side supports down until they are positioned below the level of your first few cuts.
5. Use the toe board levers to level the log if desired.

To Level A Tapered Log:

Use the toe board levers to raise either end of a tapered log, if desired.

3.7.3 Sawmills equipped with H1, H2 or H3 hydraulics



CAUTION! Make sure the clamps and the toe boards are below bed level before loading a log onto the bed. Also, be sure the cutting head is moved far enough forward so the log does not hit it.

To Load Logs:

1. Raise the side supports.
2. Place the log at the foot of the loading ramps. Loop the rope around the log. Using a winch, roll the log onto the sawmill bed.

See Figure 3-15.

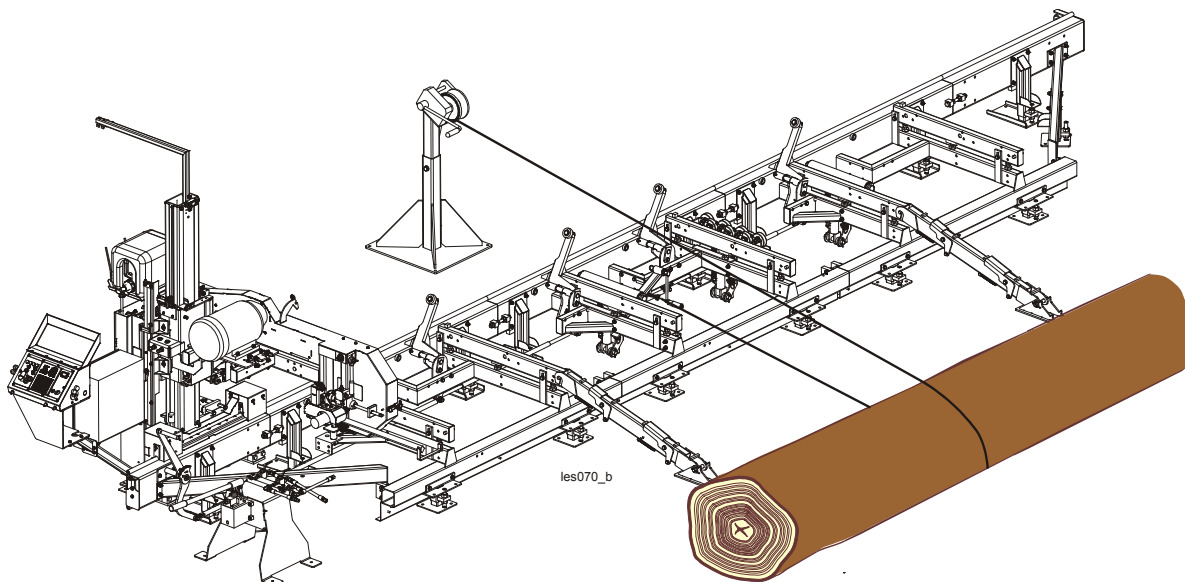

FIG. 3-15

NOTE: Logs also may be loaded onto the mill with a forklift or other equipment specifically designed for that purpose.

To Turn Logs:

1. Disengage the clamp.
2. Raise the log turning rollers (if equipped). To do this, make sure the release valve is closed (the valve screw is completely screwed in), then set the lever of the log turning rollers valve to the "1" position. Using the pump lever, raise the log turning rollers. To lower the log turning rollers, open the release valve (loosen the valve screw until the rollers are lowered completely).

See Figure 3-16.

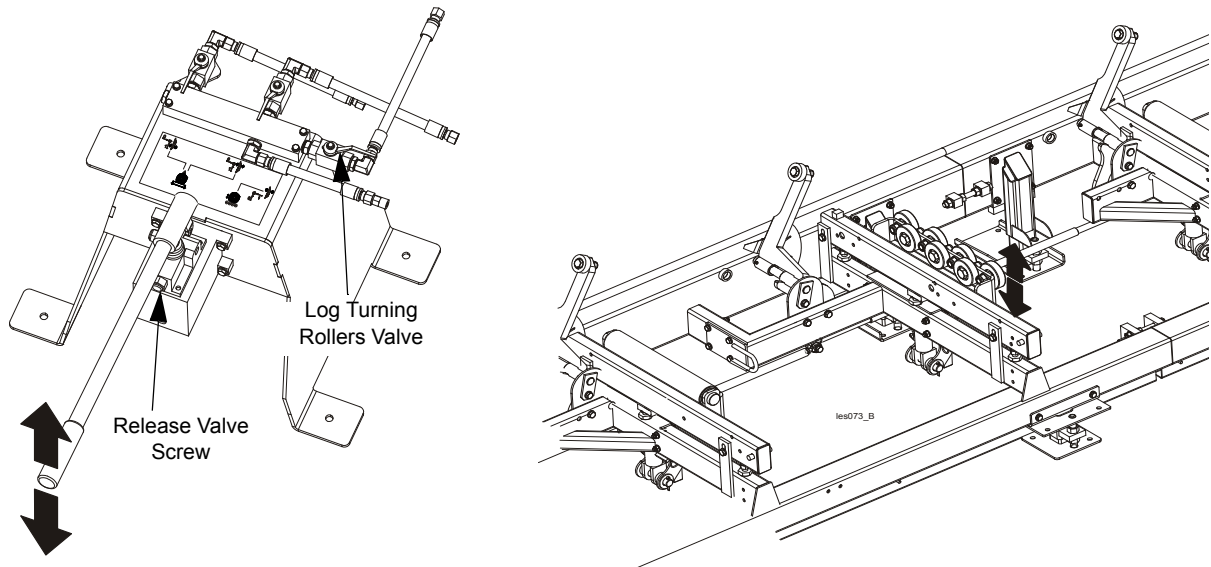

FIG. 3-16

3. Use the cant hook to turn the log on the sawmill bed.
4. Clamp the log.

To Clamp Logs:

1. Position the clamp against the log.
2. Move the clamp down far enough so that it is below your first few cuts. Using the clamp lever, clamp the log against the side supports.

See Figure 3-17.

FIG. 3-17

3. Make sure the side supports are positioned low enough for the blade to pass over them. If they are not, back the clamp off slightly and push the side supports down until they are positioned below the level of your first few cuts.
4. Use the toe board levers to level the log if desired.

To Level A Tapered Log:

Be sure the release valve is closed (the valve screw is completely screwed in). Set the front and/or rear toe board valve levers to the "1" position. Using the pump lever, raise either end of a tapered log, if desired. To lower the toe boards, open the release valve (loosen the valve screw until the toe boards are lowered completely).

See Figure 3-18.

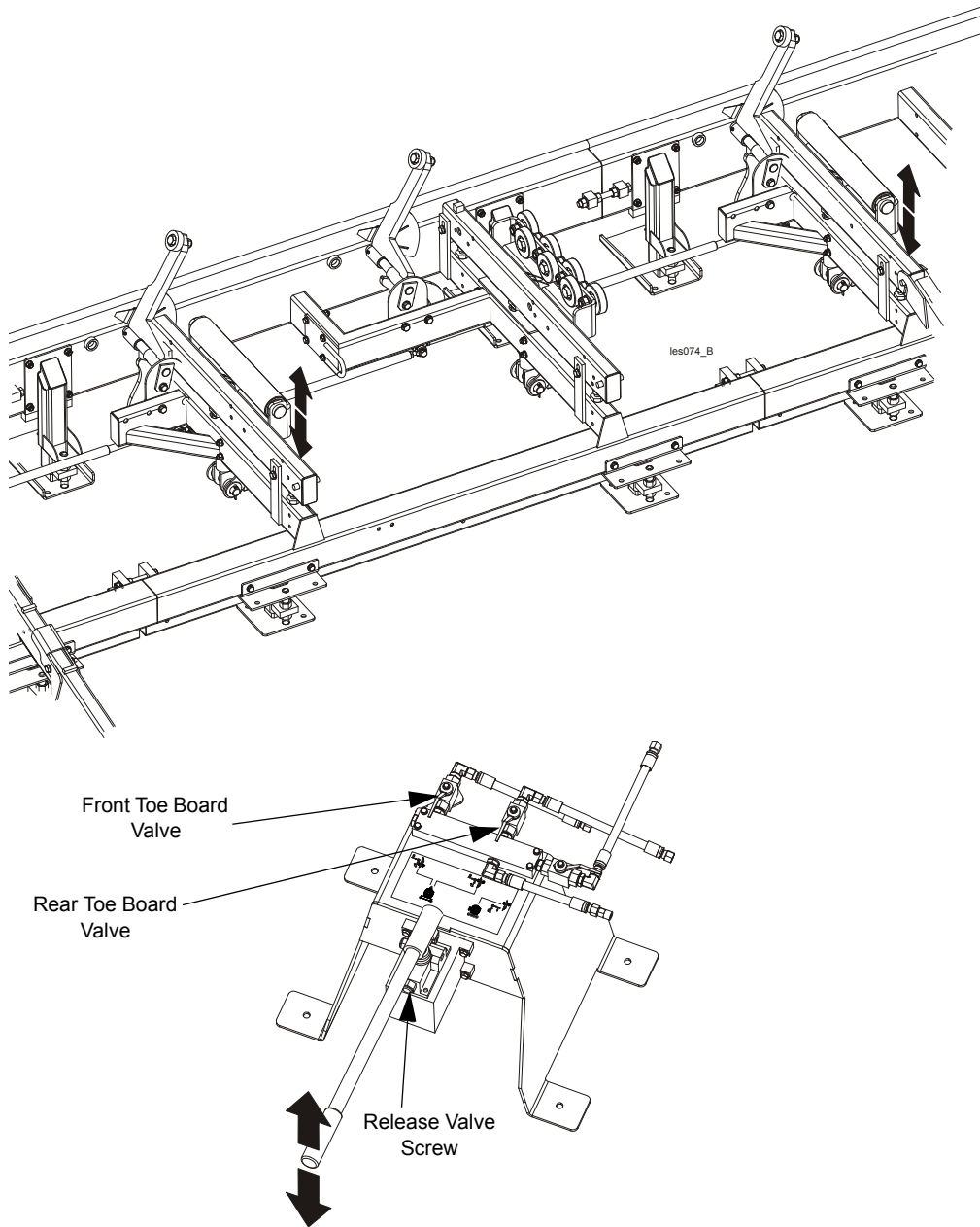

FIG. 3-18

3 SETUP & OPERATION

Up/Down Operation

3.8 Up/Down Operation

1. Install a blade and check for correct blade tension. ([See Section 2.4.](#))
2. Set the cutting head to the desired height. (The blade height scale shows the height of the blade above the bed rails.)



See **Figure 3-19**. The up/down switch is located on the right side of the control panel. Push the switch up to raise the cutting head; push the switch down to lower the cutting head. Hold the switch in position until the cutting head reaches the desired height, then release.

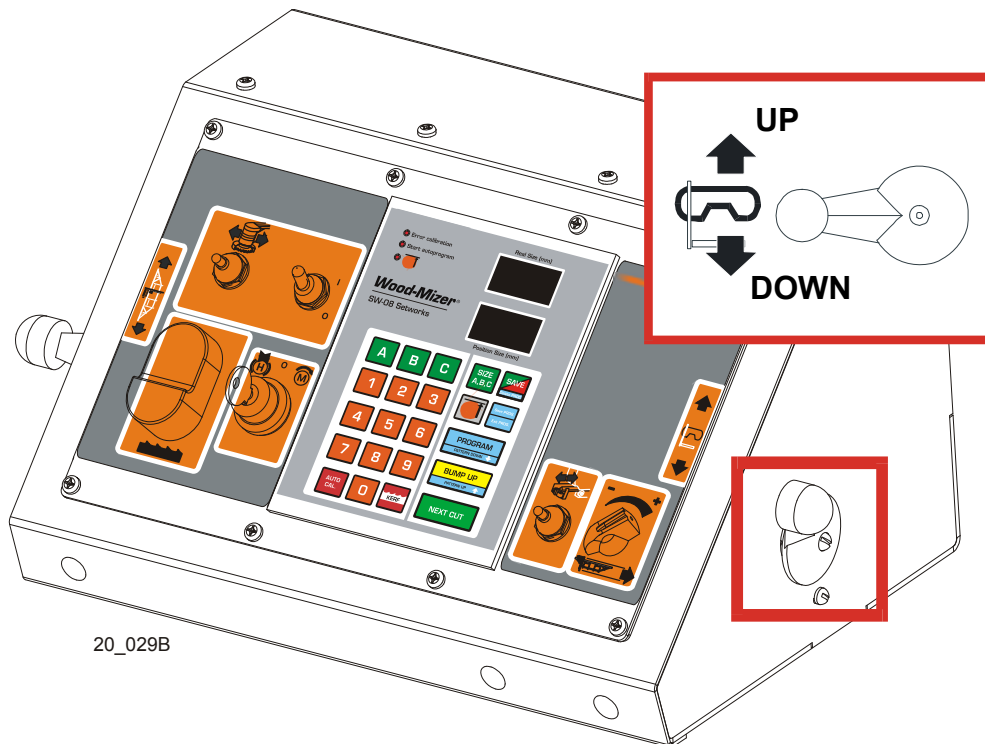

FIG. 3-19

The up/down switch is designed to return to the neutral position when released. If the switch remains engaged, manually move it to the neutral position. Repair the switch.



CAUTION! DO NOT try to force the carriage above the 35" (88 cm) mark or below the 1" (2.54 cm) mark. Damage to the up/down system may result.

3.9 Blade Guide Arm Operation

1. Look down the length of the log to see its maximum width. The outer blade guide should be adjusted to clear the widest section of the log by less than about 25 mm.
2. Use the blade guide toggle switch on the control panel to adjust the outer blade guide as necessary. Push the switch to the left to move the arm in. Push the switch to the right to move the arm out.



See Figure 3-20.

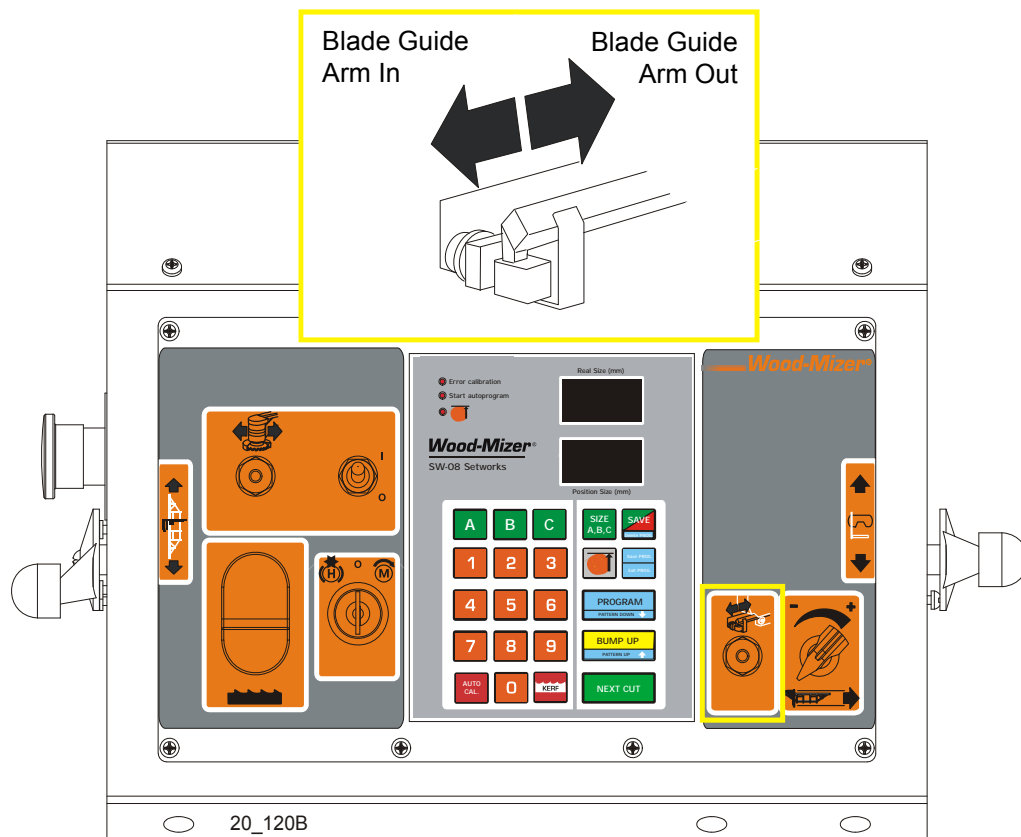
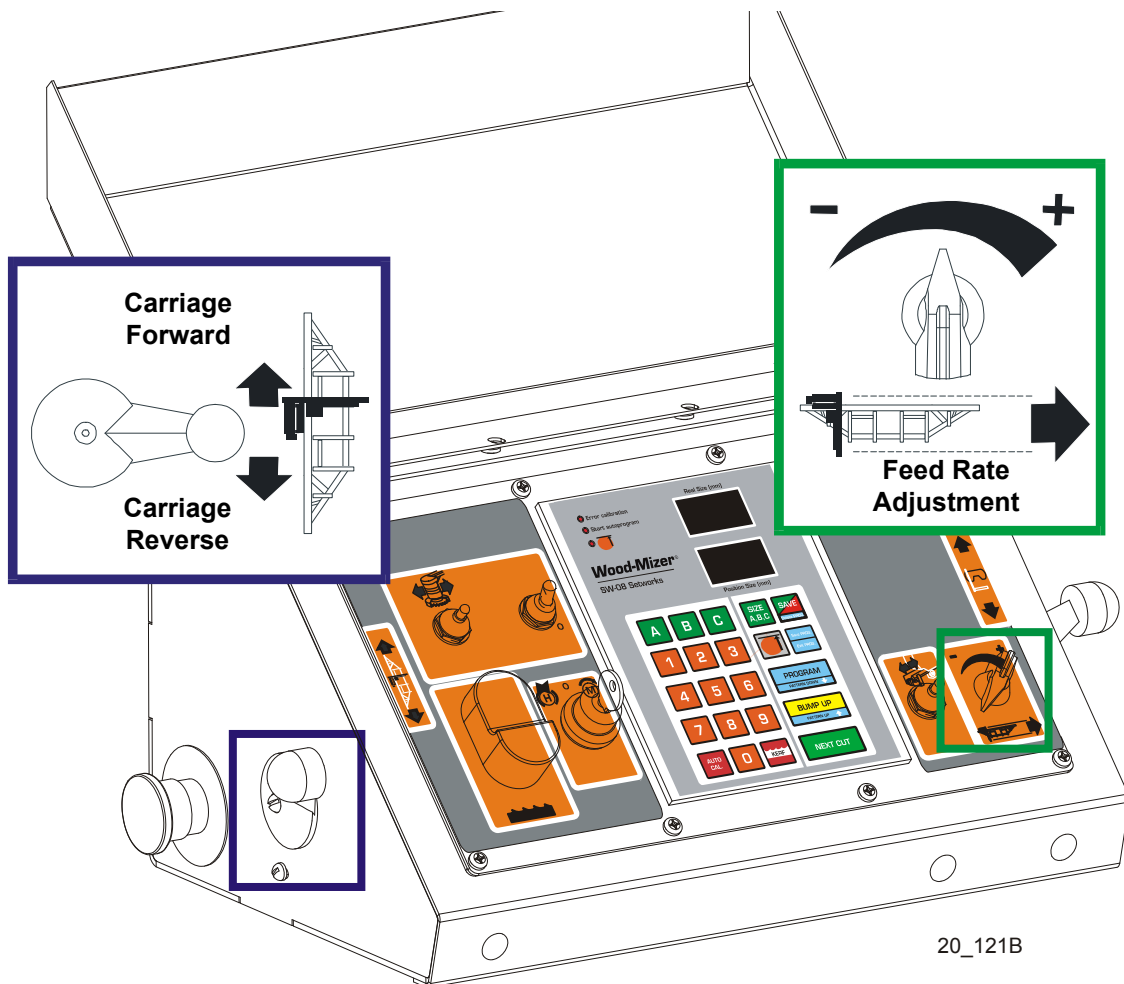

FIG. 3-20

3.10 Power Feed Operation

See Figure 3-21. The power feed system moves the carriage forward and backward by using two switches on the control panel.



20_121B

FIG. 3-21

Carriage Feed Rate



The carriage feed rate switch controls the speed at which the carriage travels forward. Turn the switch clockwise to increase speed. Turn it counterclockwise to reduce speed.

Carriage Forward and Reverse

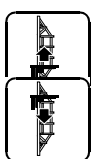

The power feed switch controls the direction in which the carriage travels. Turn the switch upward to move the carriage forward. Turn the switch down to move the carriage backward.

NOTE: Always disengage the blade before returning the carriage and raise the carriage slightly to make sure the blade clears the log.

The middle position (shown in the figure above) is the neutral position. The power feed switch is designed to return to the neutral position when released. If the switch remains engaged, manually move it to the neutral position. Repair the switch. ([See Section 4.2.](#))

 **WARNING!** Be sure the power feed switch is in the neutral position before turning the key switch to the ON position. This prevents accidental carriage movement which may cause serious injury or death.

Feed Rate

HINT: To get a straight cut in the first part of the log, feed the blade into the log at a slow speed. This stops the blade from flexing and dipping up or down. Turn the carriage feed rate switch to a slow speed until the whole width of the blade has entered the cut. Then use the carriage feed rate switch to increase the feed rate as desired. Maximum feed rate varies with width and hardness of the wood. Over-feeding results in motor and blade wear, and also produces a wavy cut.



1.



Stop the carriage at the end of the cut by turning the carriage feed rate switch counterclockwise until the carriage stops moving.

2. Using the STOP button, disengage the blade. This will stop the blade. Remove the board from the log.

 **CAUTION!** Be sure to stop the blade when returning the carriage. This will not only prevent the blade from being pulled off and ruined by a wood sliver, but also will increase the life of the blade.

3. Return the carriage to the front of the mill by turning the power feed switch down. The power feed motor will bypass the carriage feed rate switch and the carriage will automatically return at the fastest speed available. **Always disengage the blade before returning the carriage for the next cut.**



4. Make sure that the blade does not catch on the end of the log. Raise the carriage slightly to make sure the blade clears the log when returned. **HINT:** Try to stop the blade while the heel of the blade is still on the log. Then bring the carriage back without adjusting the blade up. This lets you keep the blade at the current height setting so you can make the next blade height adjustment more quickly.

3.11 Cutting The Log

The following steps guide you through normal operation of the Wood-Mizer sawmill.

1. Once the log is placed where you want it and clamped firmly, position the blade close to the end of the log.
2. Use the blade height scale to determine where to make your first cut. ([See Section 3.13.](#)) Set the blade to the desired height with the up/down switch. Make sure that the blade will clear both side supports and the clamp.
3. Adjust the outer blade guide to clear the widest section of the log using the blade guide toggle switch.



Make sure all guards and covers are in place. Engage the blade. To do this, turn the key switch to the "M" position and press the START button.

5. To prevent sap buildup on the blade, open the water bottle valve so that water flow to the blade. ([See Section 2.19.](#))
6. Feed the blade into the log slowly. ([See Section 3.10.](#)) Once the blade completely enters the log, increase the feed rate as desired. Always try to cut at the fastest speed you can while keeping an accurate cut. Cutting too slowly will waste blade life and lower production!
7. As you get to the end of the log, slow down the feed rate. When the teeth exit the end of the log, turn the power feed switch to the neutral position. Then disengage the blade using the STOP button. Remove the board that you have just cut from the log.
8. Use the power feed switch to move the carriage to the front of the mill. Always disengage the blade before returning the carriage for the next cut.
9. Repeat until the first side of the log is cut as desired. Set aside the usable flitches (boards with bark on one or both sides). You can edge them on the mill later.
10. Lower the toe boards, if they were used. Remove the clamp and turn the log 90 or 180degrees. Make sure the flat on the log is placed flat against the side supports if turned 90degrees. Make sure it is placed on bed rails if turned 180 degrees. If the log was turned 90degrees and you are using toe boards to compensate for taper in the log, raise the front or rear toe board again on the second side of the log until the heart is parallel with the bed.
11. Repeat the steps used to cut the first side of the log until the log is square. Cut boards from the remaining cant by adjusting the blade height for the thickness of boards that you want.

Example: Remember that the blade cuts a 1/16 - 1/8" (1.5-3.0 mm) wide kerf. If you want 1" (25.4 mm) thick boards, lower the carriage 1 1/16 - 1 1/8" (27-28.6 mm) for each board.

3.12 Edging

The following steps guide you through edging boards on the Wood-Mizer sawmill.

1. Raise the side supports to $\frac{1}{2}$ the height of the flitches, or the boards that need to be edged.
2. Stack the flitches on edge against the side supports.
3. Clamp the flitches against the side supports. (Wider flitches should be placed to the clamp side. When they are edged, flip them over to edge the second side without disturbing the other flitches or without having to pull them from the middle of the stack.)
4. Adjust the blade height to edge a few of the widest boards.
5. Loosen the clamp and turn the edged boards over to edge the other side.
6. Repeat steps 2-4.
7. Loosen the clamp and remove the boards that have good clean edges on both sides. Clamp the remaining flitches and repeat steps 2-5.

3.13 Blade Height Scale

See **Figure 3-22**. The blade height scale is attached to the cutting head frame. It includes:

- a blade height indicator
- an inch scale.

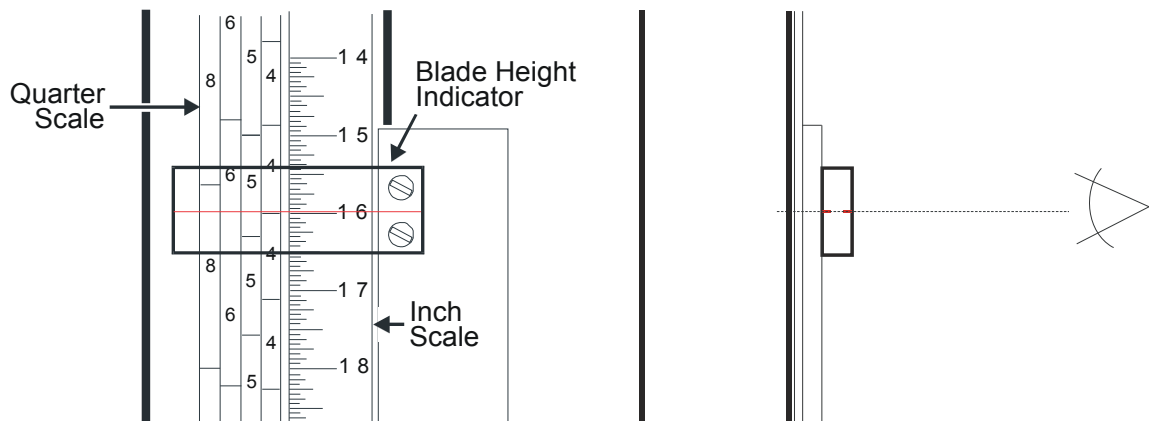

FIG. 3-22

Blade Height Indicator

The blade height indicator has two horizontal, red lines on both sides. Readings should be taken with eyes level with the indicator, when the two red lines are in line. This will allow to avoid the parallax error (different scale readings depending on the angle of vision).

The Inch Scale

The horizontal red line on the blade height indicator shows how many inches the bottom of the blade is above the bed of the mill. If you know the height of your blade at each cut, you can determine the thickness of lumber you are sawing.

Example: You want to cut 1" (25 mm) random width boards from a log. Position the blade for the first cut. Move the carriage to an even measurement on the inch scale. Make a trim cut. Return the carriage for the second cut and lower it 1 1/8" (28 mm) below the original measurement. (The extra 1/8" (3 mm) allows for saw kerf and shrinkage of the lumber.)

The yellow area on the scale identifies where the blade could encounter a side support or log clamp. Check that these items are below the blade level before sawing.

The Quarter Scale

See Table 3-2. Two quarter scales are provided with four sets of marks. Each set represents a specific lumber thickness. Saw kerf and shrinkage allowance are included, but actual board thickness will vary slightly depending on blade thickness and tooth set.

To choose which scale to use, determine what finished thickness you want to end up with. The Grade Hardwood Quarter Scale provides thicker finished boards usually required by commercial buyers. The Standard Quarter Scale allows for kerf and shrinkage of finished boards suitable for most custom applications. Always check with your customer before you saw to determine what actual finished thickness is required.

Standard Quarter Scale		Grade Hardwood Quarter Scale	
Scale	Actual Board Thickness	Scale	Actual Board Thickness
4/4	1" (25 mm)	4/4	1 1/8" (29 mm)
5/4	1 1/4" (32 mm)	5/4	1 3/8" (35 mm)
6/4	1 1/2" (38 mm)	6/4	1 5/8" (41 mm)
8/4	2" (51 mm)	8/4	2 1/8" (54 mm)

TABLE 3-2

To use the quarter scale, look at the blade height indicator. Line up the horizontal red line on the indicator with the nearest mark on the scale you want to use. Make a trim cut. When you return the carriage for a second cut, lower the carriage to the next mark on the scale. This mark shows where the blade should be positioned to cut a certain thickness of lumber, without having to measure on the inch scale.

Example: You want to cut 1" (25 mm) (4/4) random width boards from a log. Position the blade for the first cut. Adjust the quarter scale so a 4/4 mark is aligned with the red line on the indicator. Make a trim cut. Return the carriage for the second cut. Now, instead of having to measure down 1 1/8" (29 mm) on the inch scale, you can simply lower the blade so the indicator is aligned with the next 4/4 mark on the quarter scale. Turn the log 90 degrees and repeat.

3.14 Water Lube Operation

The Water Lube System keeps the blade clean. Water flows from a 5-gallon (18.9 liter) bottle through a hose to the blade guide where the blade enters the log. A valve in the bottle cap controls the amount of water flow.

See Figure 3-19. Open the valve on the water bottle to start water flow. A stream of water flow to the blade only when the main engine is turned on.

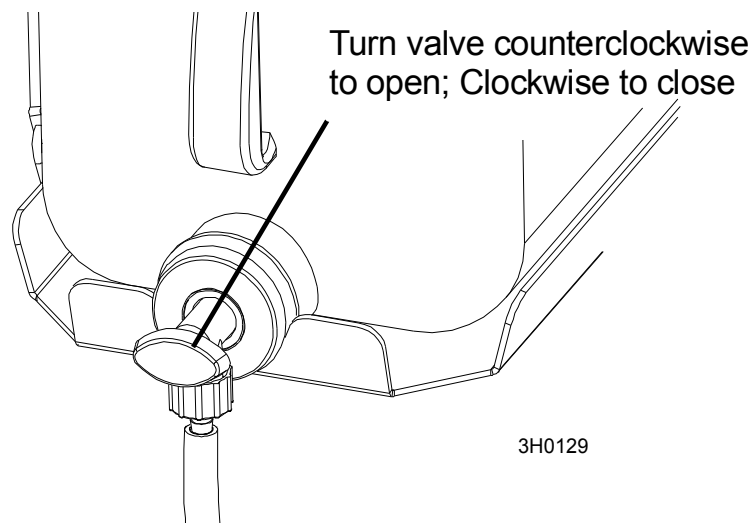

FIG. 3-19

Not all types of wood require the use of the Water Lube System. When it is needed, use just enough water to keep the blade clean. This saves water, and lowers the risk of staining the boards with water. Usual flow will be 1-2 gallons (3.8-7.6 liters) per hour. A squirt of liquid dishwashing detergent in the water bottle will help clean the blade when cutting wood with a high sap content.



WARNING! Use ONLY water with the water lube accessory. Never use flammable fuels or liquids. If these types of liquids are necessary to clean the blade, remove it and clean with a rag. Failure to do so may result in serious injury or death.

Before removing the blade, start the motor with the START button. Let the blade spin with water running on it for about 15 seconds. This will clean the blade of sap buildup. Wipe the blade dry with a rag before storing or sharpening.

If you are sawing in freezing temperatures, remove the water lube bottle from the sawmill when done sawing and store it in a warm place. Blow any remaining water from the water lube hose.

SECTION 4 MAINTENANCE

This section lists the maintenance procedures that need to be performed.

The Short Interval Maintenance Schedule lists procedures that need to be performed every 4, 8 or 24 hours. *The Maintenance Log* lists procedures that need to be performed every 50, 100, 200, or 1000 hours. Keep track of machine maintenance by filling in the machine hours and the date you perform each procedure.



This symbol identifies the interval (hours of operation) at which each maintenance procedure should be performed.

Be sure to refer to option and engine manuals for other maintenance procedures.

4.1 Wear Life

See Table 4-1. This chart lists estimated life expectancy of common replacement parts if proper maintenance and operation procedures are followed. Due to the many variables which exist during sawmill operation, actual part life may vary significantly. This information is provided so that you may plan ahead in ordering replacement parts.

Part Description	Estimated Life
B57 Blade Wheel Belts	500 hours
Blade Guide Rollers	1000 hours
Drive Belt	1250 hours

TABLE 4-1

4.2 Blade Guides

1. Check the rollers for performance and wear every blade change. Make sure the rollers are clean and spinning freely. If not, rebuild them. Replace any rollers which have worn smooth or have become cone shaped. See The LT20 Parts manual for blade guide rebuild kits and complete roller assemblies.

See Figure 4-1.

2. Make sure the blade screw in the top center of the C-frame is 1/16" (1.5 mm) below the bottom of the blade. If not, loosen the nut and adjust the screw as necessary. Failing to maintain this adjustment will lead to early blade breakage.

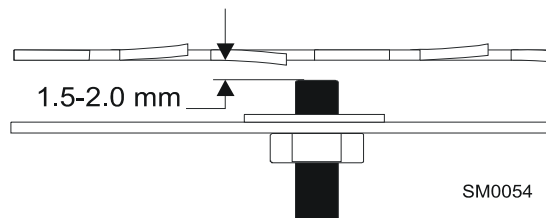

FIG. 4-1

4.3 Sawdust Removal

1. Remove the excess sawdust from the blade wheel housing and sawdust chute every blade change.

4.4 Carriage Track, Wiper & Scrapers

See Figure 4-2.

1. Clean the upper and lower track rails to remove any sawdust and sap buildup every eight hours of operation. Lubricate the lower track rail by wiping it with Dexron III ATF. 8
2. Remove sawdust from the upper cam housings. Loosen the thumb screws on the upper cam housing covers and open. Brush any sawdust buildup from the housings. 8
3. Check the track scrapers as needed. Make sure the scrapers fit firmly against the rail. If a track scraper needs to be adjusted, loosen the thumb screw, push the scraper downward until it fits firmly against the rail, and retighten the thumb screw.

Clean and lubricate the upper track wiper every twenty-five hours of operation. Unbolt the wiper, remove it from the sawmill, and remove any sawdust buildup. Soak the felt wiper with Dexron III transmission fluid, 10W30 motor oil or 3-in-1 turbine oil. 25

CAUTION! Reinstall the track wiper so that it lightly touches the track rail. If the wiper presses too firmly against the rail, it can cause the power feed to bind.

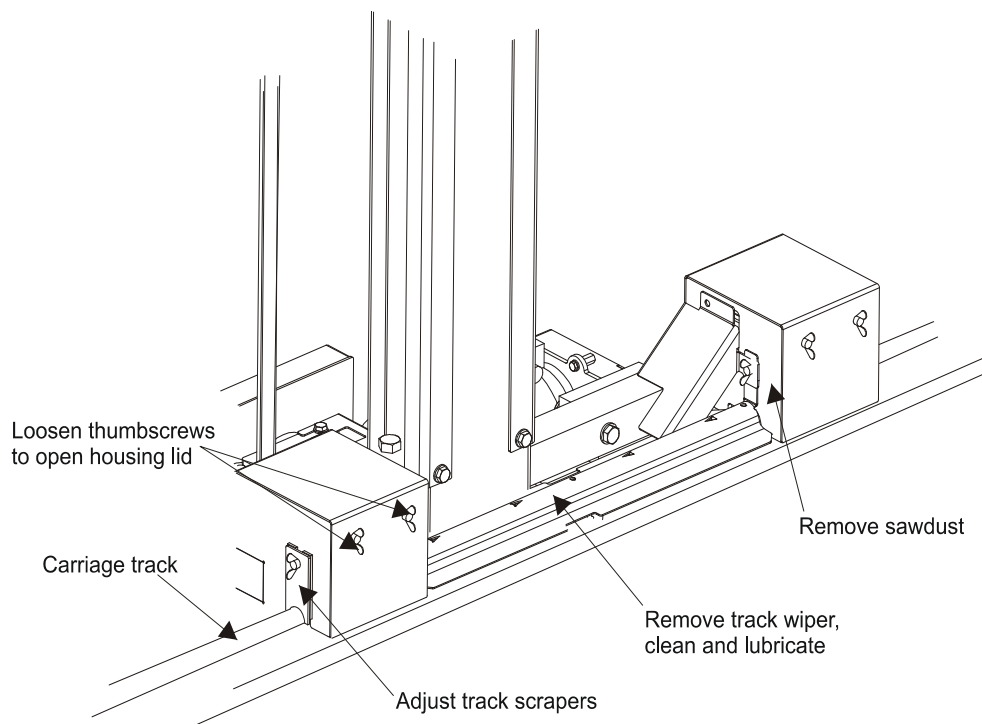

FIG. 4-2

4.5 Vertical Mast Rails

Lubricate the vertical mast rails with WD40, clean and wipe them dry every 50 hours of operation.

50



CAUTION! Never use grease on the mast rails as it will collect sawdust.

4.6 Miscellaneous

1. Apply a thin film of a lithium grease to the blade guide arm to help prevent it from rusting.
50
2. Lubricate the log turner (if equipped) with a lithium grease every fifty hours of operation. Lubricate the turner pivot points (e.g. with WD-40).
50
3. Grease the side supports with a lithium grease every 50 hours of operation.
50
4. Oil all chains with an easily penetrating oil such as WD-40.
50



CAUTION! Do not use chain lube. It causes sawdust buildup in chain links.

5. Check the mill alignment every setup. See Section 5, Alignment.
6. Make sure all safety warning decals are readable. Remove sawdust and dirt. Replace any damaged or unreadable decals immediately. Order decals from your Customer Service Representative.

4.7 Blade Tensioner

1. Grease the tensioner handle screw with a lithium grease every fifty hours of operation, but at least once a week.

50

See Figure 4-3.

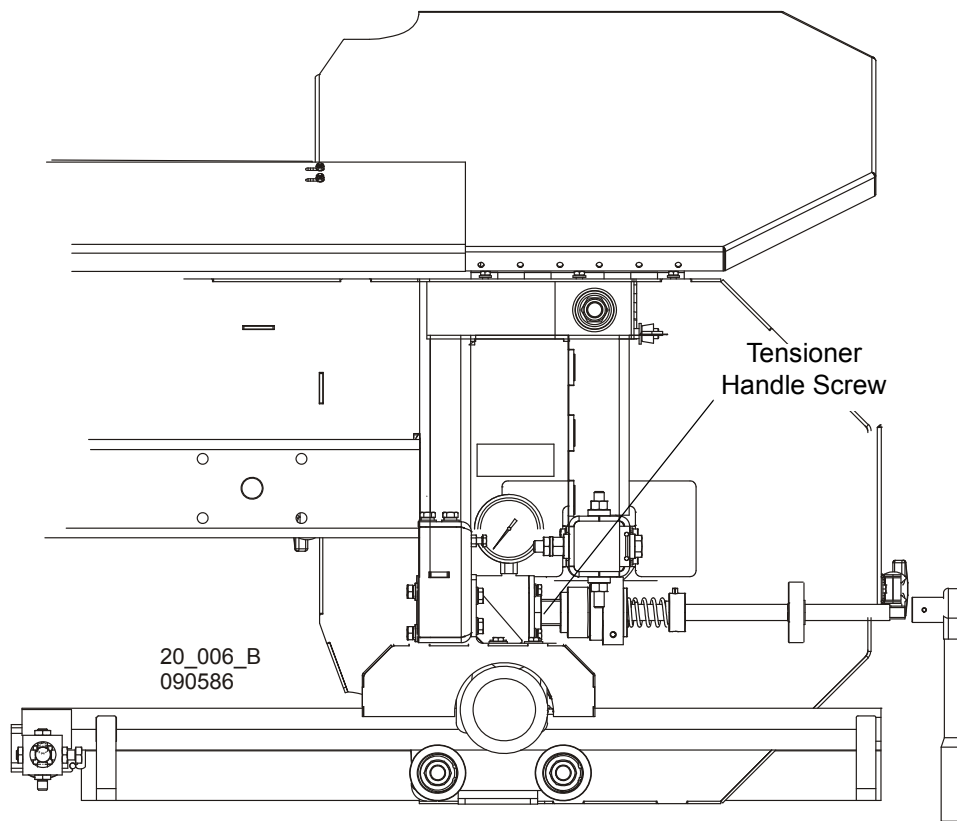



FIG. 4-3

4.8 Blade Wheel Belts

-  1. Check the blade wheel belts for wear every 50 hours of operation. Replace as needed.
2. Periodically check all belts for wear. Replace any damaged or worn belts as needed.

4.9 Brake Pads Adjustment (Gas / Diesel Sawmills Only)

200

Check the brake pads for wear every 200 hours of operation. Replace if damaged or worn.

Adjust the brake pads if the blade does not stop quickly, unusual sounds occur when the brake is applied, or a sudden change is noticed in the clutch/brake lever position when the clutch is disengaged.



WARNING! Do not for any reason adjust the brake pads with the engine running. Doing so may result in serious injury.

Open the blade housing cover.

See Figure 4-4. Loosen the locking bolts shown below. Adjust the brake pads so the blade stops no more than 10 seconds after disengaging. The brake pads should enter the grooves in the drive pulley when the brake is applied. If they are not, it can lead to their premature wear.

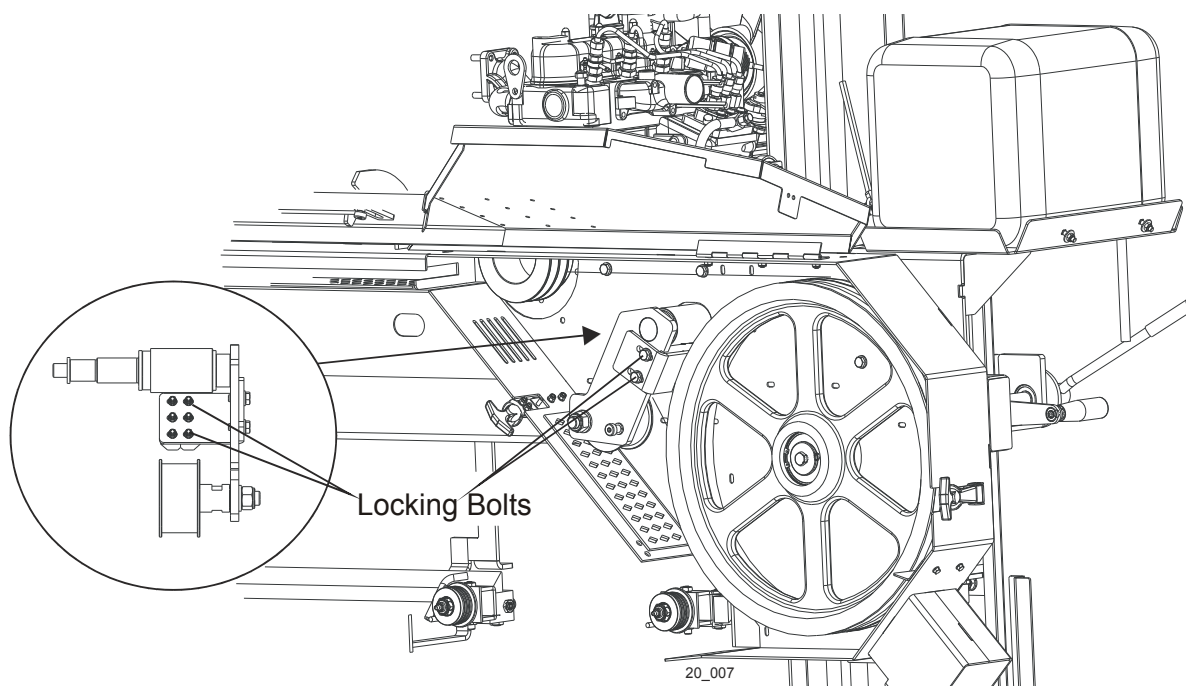



FIG. 4-4

4.10 Drive Belt Adjustment

 **WARNING!** Do not for any reason adjust the drive belts with the motor running. Doing so may result in serious injury.

 **See Table 4-2.** Check the drive belt tension after the first 20 hours, and every 50 hours thereafter. See the table below for drive belt tension specifications for your sawmill.

Motor/Engine	Belt Tension
E11	7/16" (11mm) deflection with 16 lbs. (3,6 KG) of deflection force (two belts)
E15, G25, D22	7/16" (11mm) deflection with 16 lbs. (7,2 KG) of deflection force (two belts)

TABLE 4-2

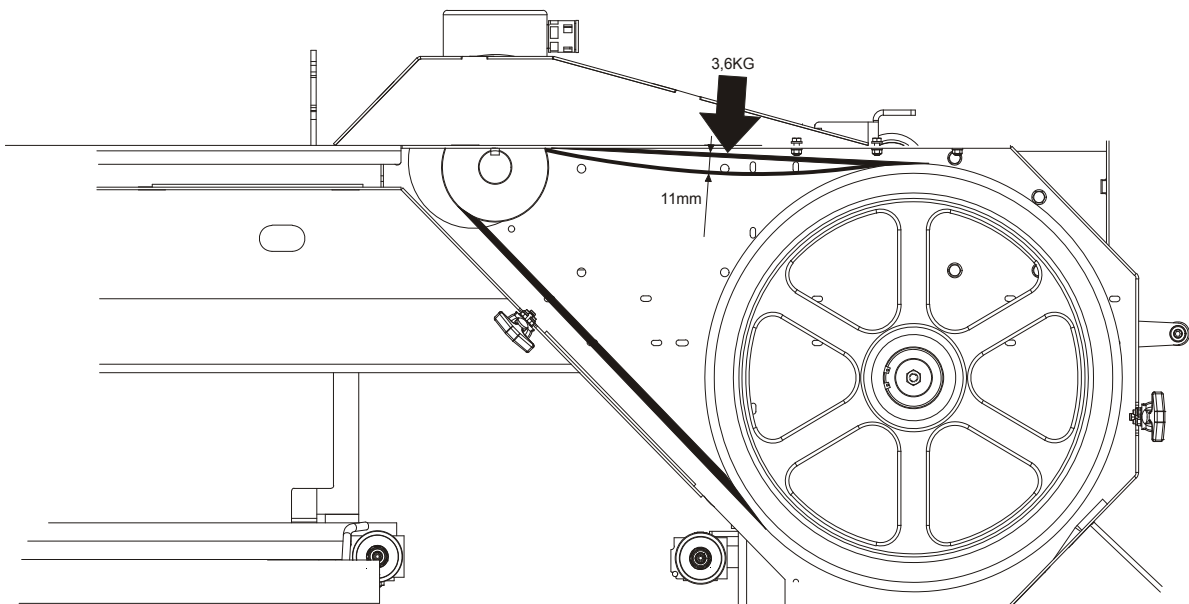

FIG. 4-5

To adjust the drive belt tension:

1. Raise the blade housing cover.

AC Sawmills

2. Loosen the four mounting bolts in the motor mount plate (See the figure below).
3. Loosen mounting bolts and using the adjustment nuts adjust the drive belt(s) tension according to the specifications given in Table 4-2.

4

MAINTENANCE *Drive Belt Adjustment*

4. Tighten the four mounting bolts.

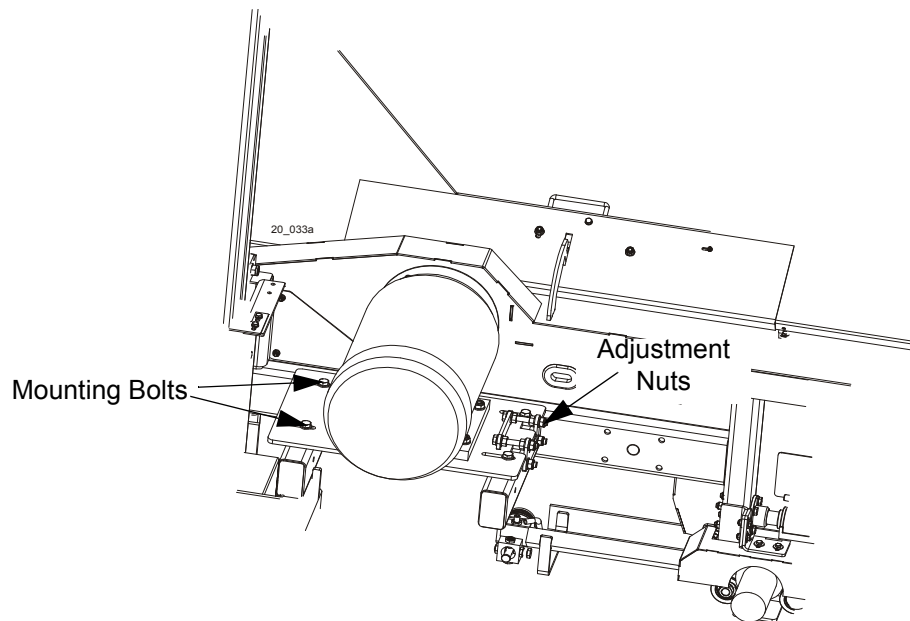
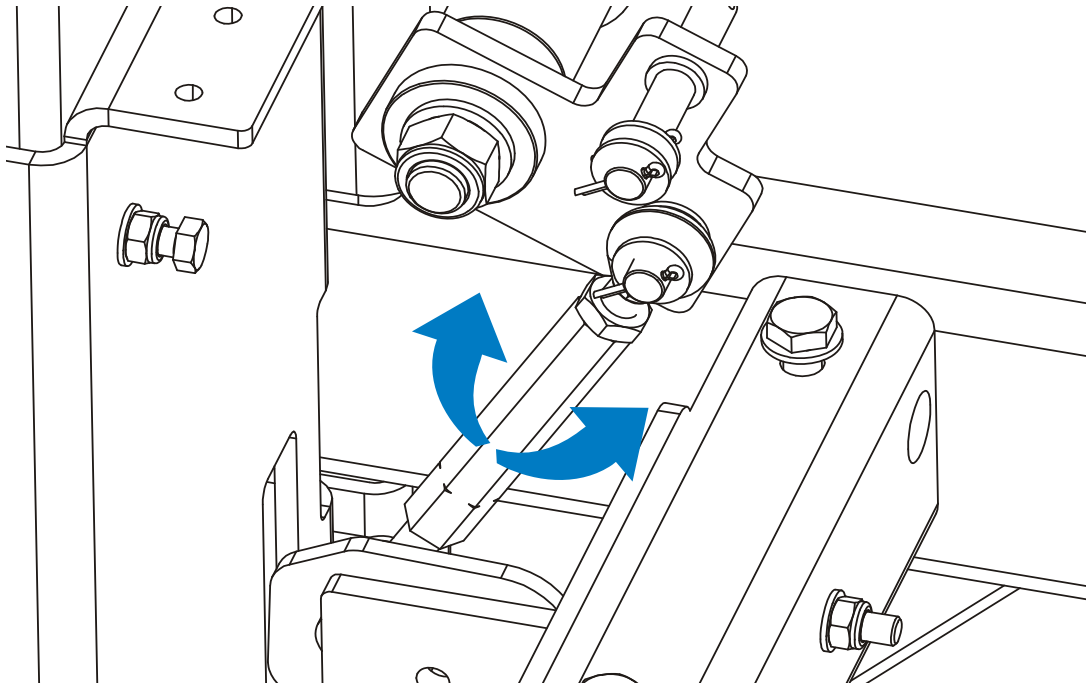

FIG. 4-6



Periodically check the belts for wear. Replace if the belt is damaged or worn.

DC Sawmills



To tighten - turn the bolt clockwise; to loosen - turn it counterclockwise.



Periodically check the belts for wear. Replace if the belt is damaged or worn.

4.11 Up/Down System

1. Adjust the up/down chain tension as needed. Measure chain tension with the cutting head all the way to the top of the vertical mast. Secure the carriage with a chain at the top, or shim it underneath. Using the adjustment nut shown in Figure 4-7, adjust the chain tension so that there is 1" (2.5 cm) deflection in the center of the chain with a 5 lbs. (2.3 KG) deflection force.

 **WARNING!** Always secure the cutting head with a chain or a brace before adjusting or inspecting the up/down system. The cutting head may fall, causing severe injury or death.

See Figure 4-7. Use the adjustment nut shown below to tension the chain.

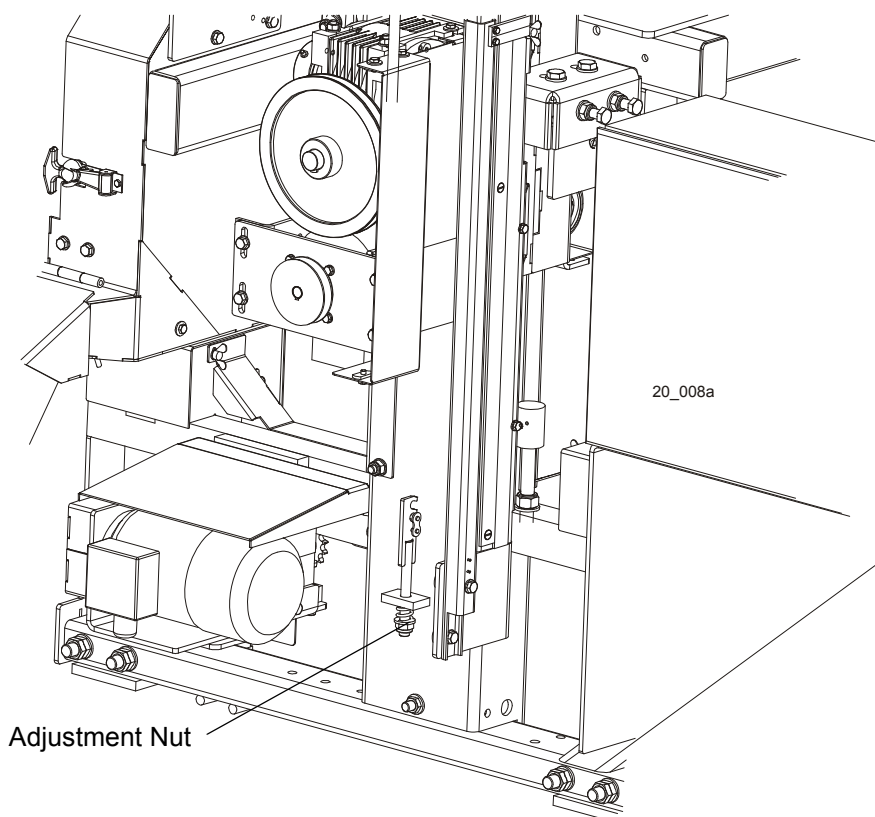



FIG. 4-7

2. Every 500 hours check the up/down chain and chain brackets for wear.

500

 **WARNING!** If you noticed the up/down chain or chain brackets wear, immediately stop the work and contact Wood-Mizer Customer Service. Failure to do so will result in serious injury or death.

3. Adjust the up/down gear belt tension as needed.

 **WARNING!** Before adjusting, always remove the key from the key switch. Failure to do so may result in serious injury.

4. Loosen the four set screws shown below. Adjust the belt tension and tighten the set screws.

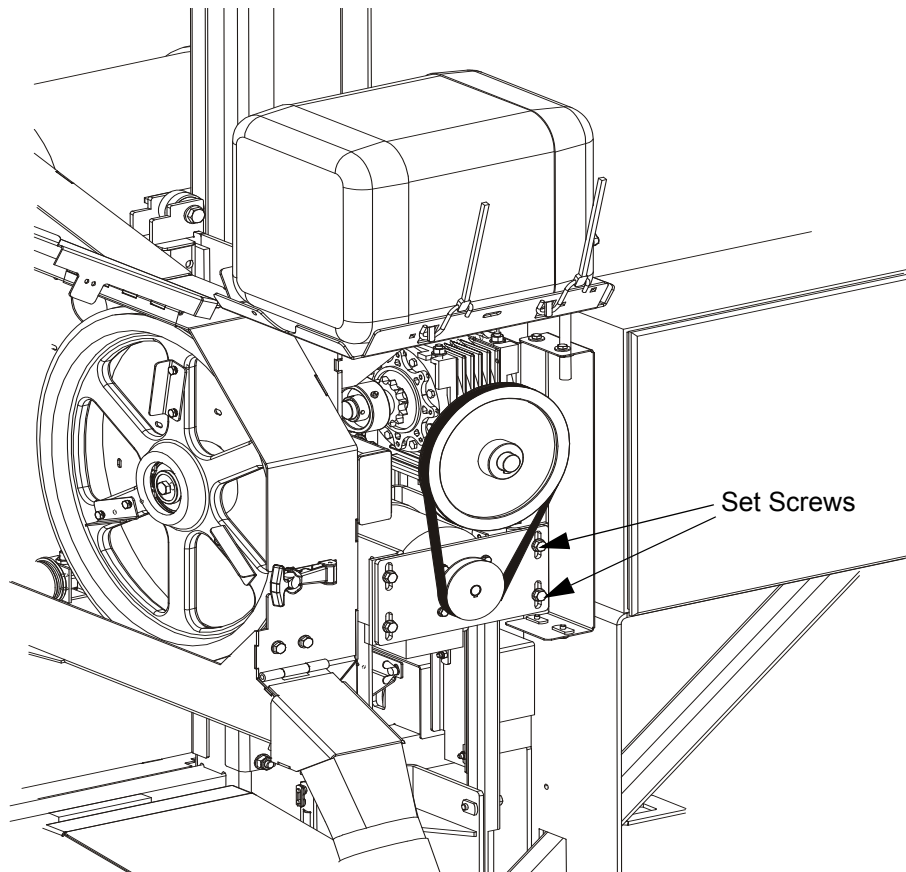



FIG. 4-8

4.12 Power Feed System

1. Adjust the power feed chain as needed.

 **WARNING!** Always remove the key from the key switch before adjusting the chain. Failure to do so may result in serious injury.

See **Figure 4-9**. Loosen the locking nut. To tighten the chain, turn the adjusting bolt clockwise. To loosen the chain, turn the adjusting bolt counterclockwise. Tighten the locking nut.

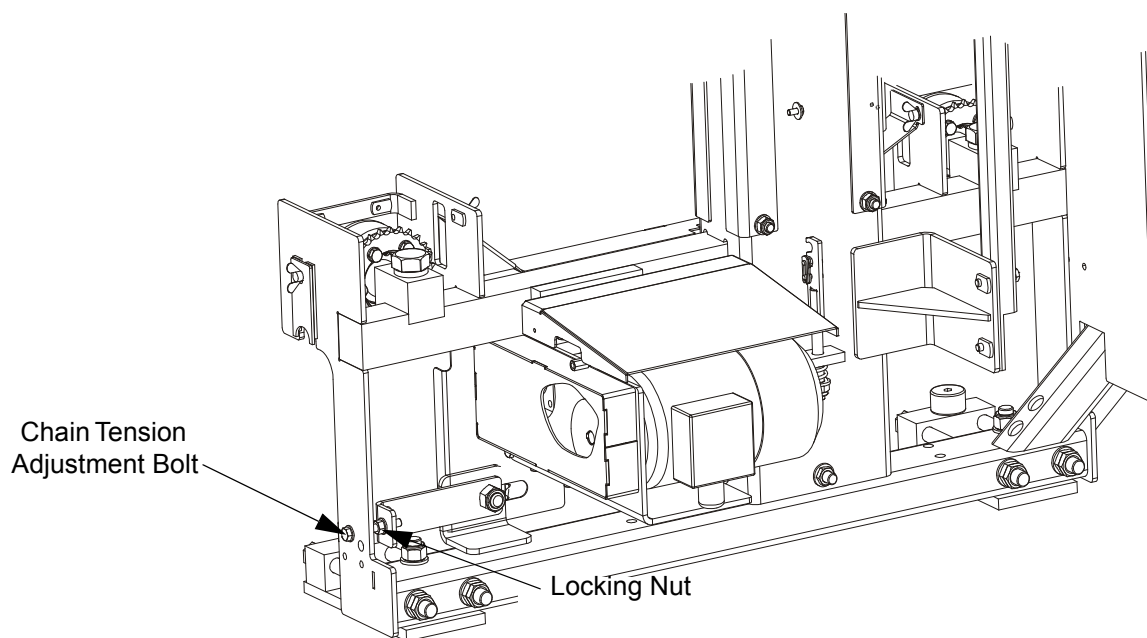



FIG. 4-9

2. If necessary, align the power feed motor pulley with the gear reducer pulley.

 **WARNING!** Remove the key from the key switch before adjusting the pulleys. Failure to do so may result in serious injury.

See Figure 4-10. Keep the pulleys aligned to avoid premature V-belt and pulleys wear.

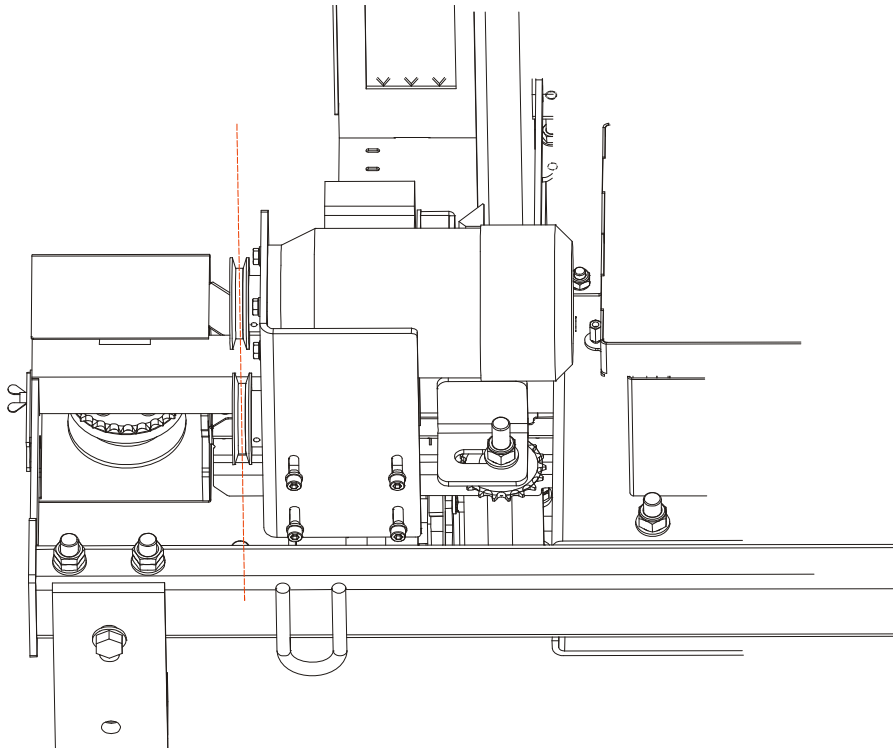

FIG. 4-10

To align the pulleys, slide one of them on the shaft appropriately.

3. Adjust the power feed gear belt tension as needed.



WARNING! Remove the key from the key switch before adjusting the belt tension. Failure to do so may result in serious injury.

See Figure 4-11. Loosen the adjustment bolts shown below. Adjust the belt tension and tighten the adjustment bolts.

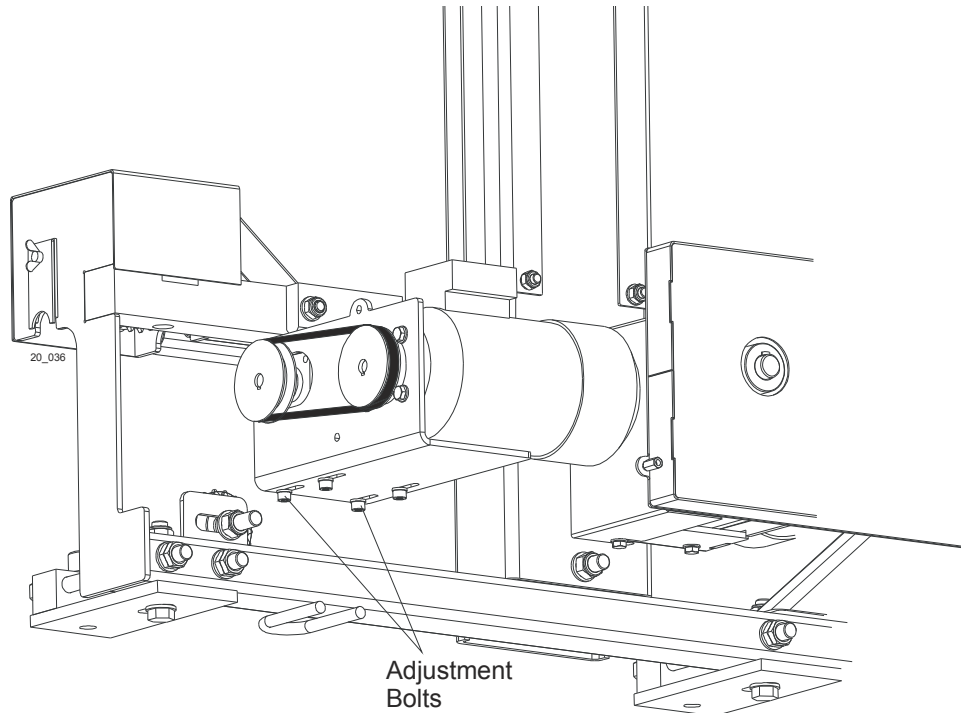

FIG. 4-11

4. If the power feed chain must be replaced, route a new chain as shown on the picture

below.

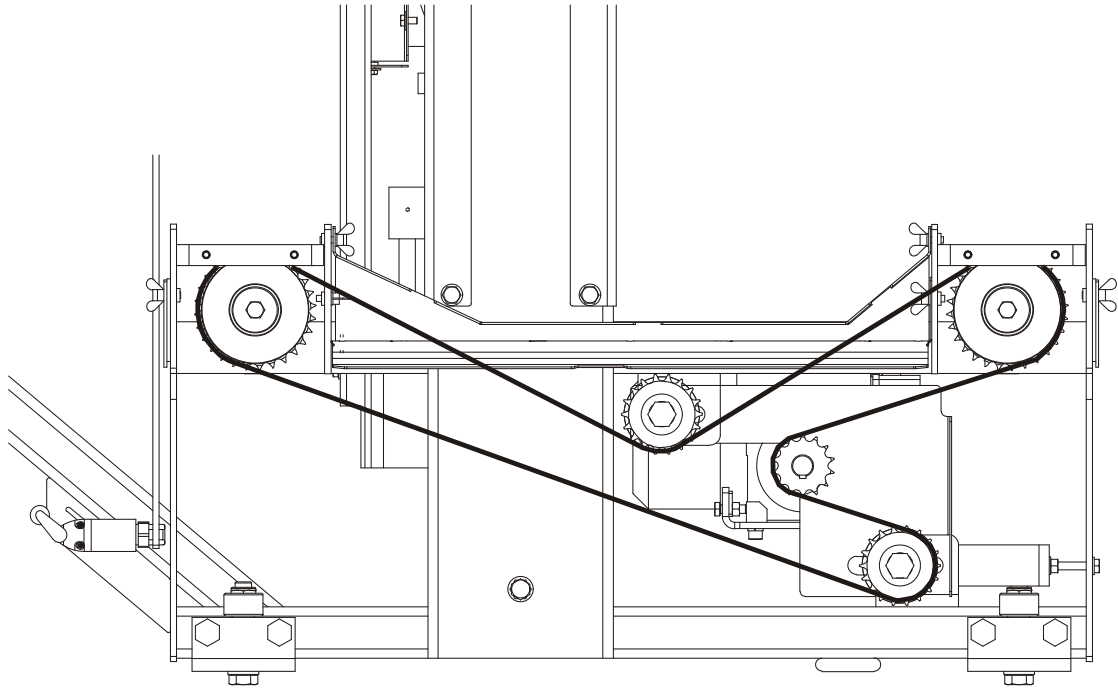

FIG. 4-11

4.13 Safety devices inspection (CE Version Only)

LT20 AC – Safety devices inspection

Safety devices on the LT20AC machine which must be checked before every shift:

- E-STOP button and its circuit inspection
- Inspection of the control circuits with the E-STOP button pressed
- Blade cover safety switches and its circuit inspection
- Motor brake and its circuit inspection

1. E-STOP button and its circuit inspection

- Turn on the blade motor;
- Press the E-STOP button located on the left side of the control box. Blade motor should be stopped. Pressing the START button shouldn't start the motor until the E-STOP button is released.

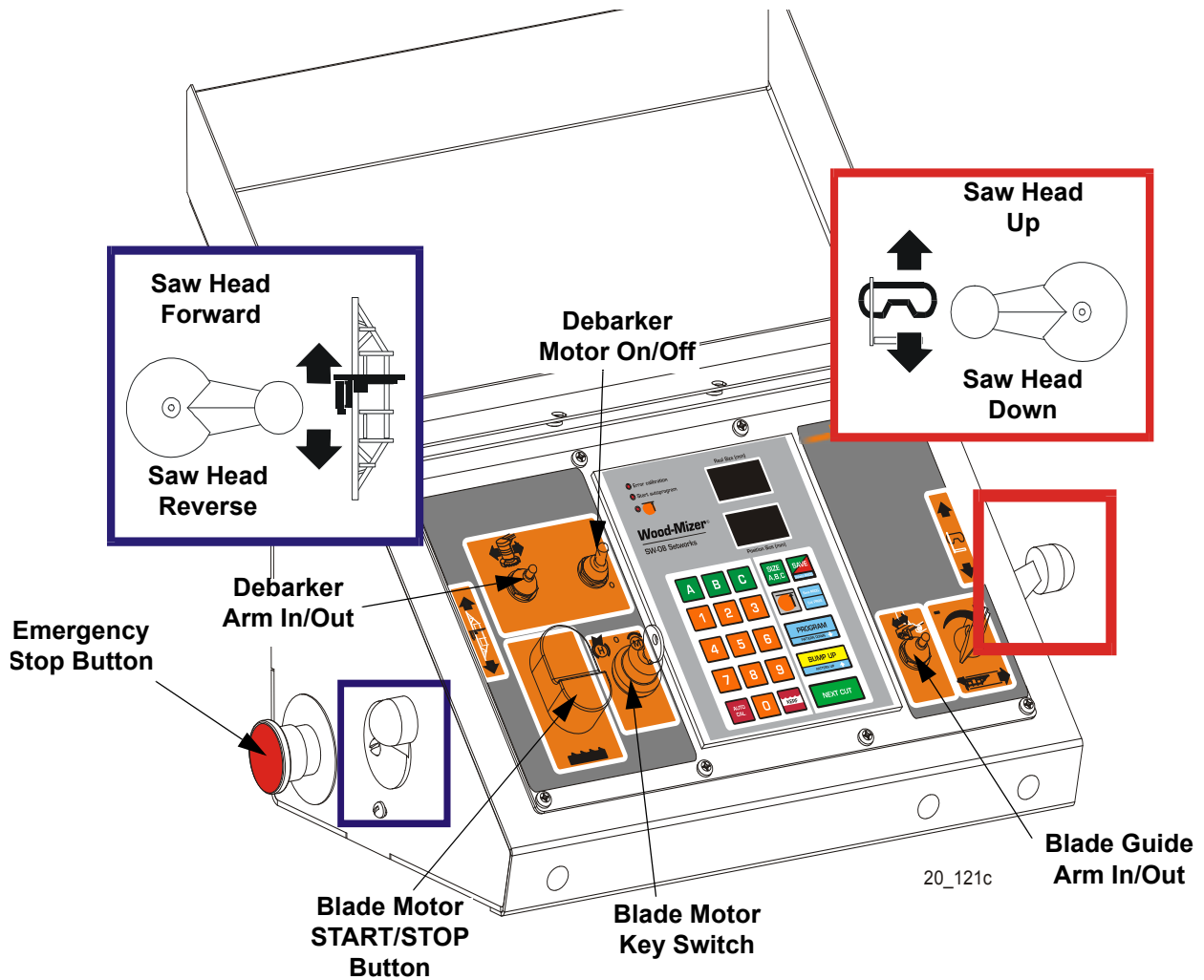

2. Inspection of the control circuits with the E-STOP button pressed

- Turn on the blade motor;
- Press the E-STOP button located on the left side of the control box. Blade motor should be stopped.
- With E-STOP button pressed try to move the saw head up and down (using switch and set-work buttons) and forward/backward using power feed switch. Both systems shouldn't start.
- With E-STOP button pressed try to start the debarker blade motor and move the debarker arm in and out. Debarker shouldn't work.
- With E-STOP button pressed try to move the blade guide arm in and out. Blade guide arm shouldn't work.

3. Blade cover safety switch and its circuits inspection.

- Turn on the blade motor;

- Open blade housing cover;
- Blade motor should be stopped;
- Try to start the motor. The blade motor should remain stopped;
- Close blade housing cover;
- Blade motor should remain stopped until re-started using START button.

4. Motor brake and its circuit inspection

- Turn on the blade motor. Stop the motor using STOP button. Measure the braking time.
- Turn on the blade motor. Stop the motor by switching the key to "0" position. Measure the braking time.
- Turn on the blade motor. Stop the motor by switching the key to "H" position. Measure the braking time.
- Braking time should always be shorter than 10 seconds. If the braking time is longer it is necessary to adjust or replace motor disc brake. See your motor option manual.

LT20 DC – Safety devices inspection

Safety devices on the LT20DC machine which must be checked before every shift:

- E-STOP button and its circuit inspection
- Inspection of the control circuits with the E-STOP button pressed
- Blade cover safety switches and its circuit inspection
- Blade brake and its circuit inspection

1. E-STOP button and its circuit inspection

- Start the engine;
- Turn the tensioner handle to engage the blade;
- Press the E-STOP button located on the left side of the control box. Engine should be stopped. Re-starting the engine shouldn't be possible until the E-STOP button is released.

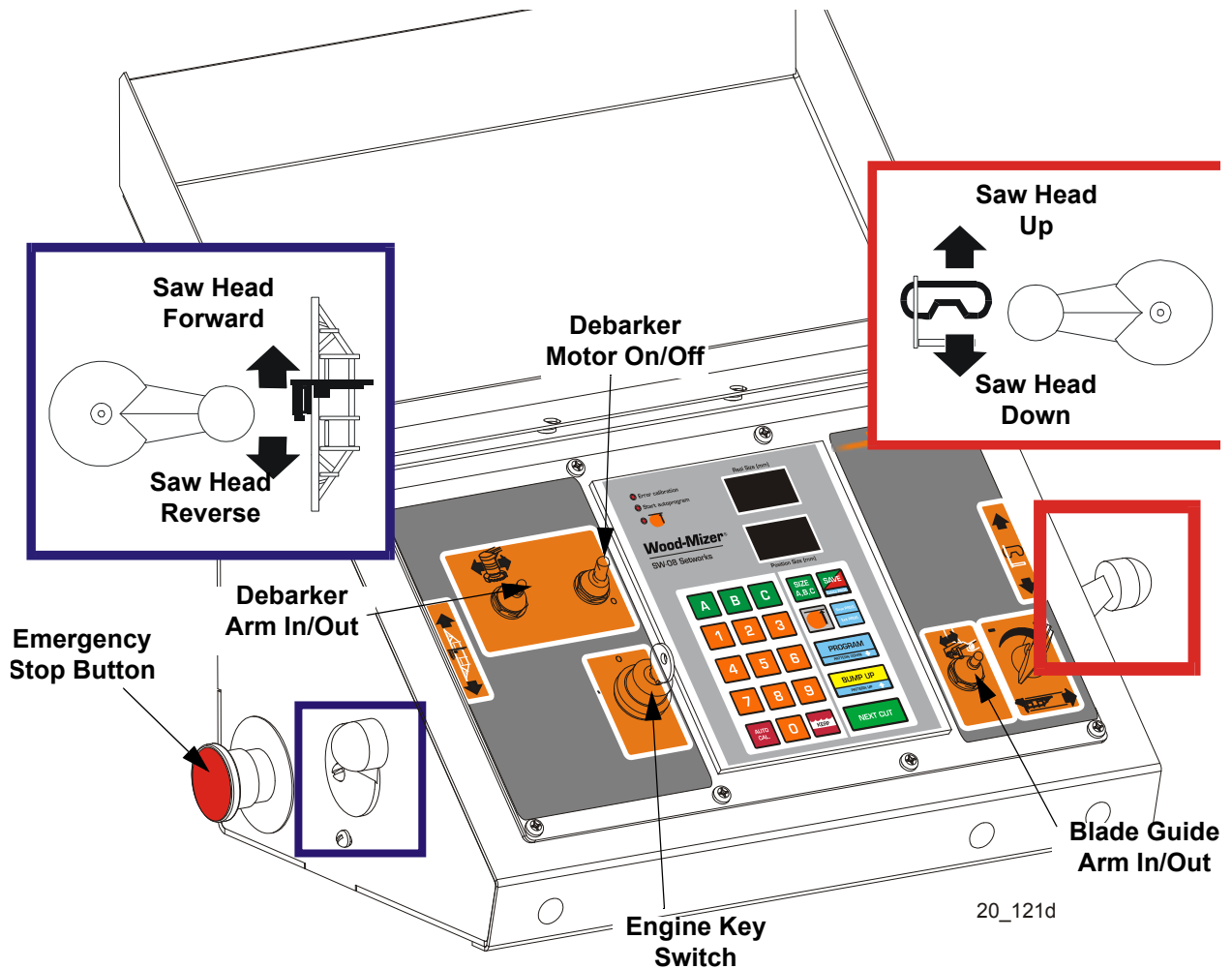

2. Inspection of the control circuits with the E-STOP button pressed

- Start the engine;
- Turn the tensioner handle to engage the blade;
- Press the E-STOP button located on the left side of the control box. Engine should be stopped.
- With E-STOP button pressed try to move the saw head up and down (using switch and set-work buttons) and forward/backward using power feed switch. Both systems shouldn't start.
- With E-STOP button pressed try to start the debarker blade motor and move the debarker arm in and out. Debarker shouldn't work.
- With E-STOP button pressed try to move the blade guide arm in and out. Blade guide arm shouldn't work.

3. Blade cover safety switch and its circuits inspection.

- Start the engine;
- Turn the tensioner handle to engage the blade;
- Open blade housing cover;
- Engine should be stopped;
- Try to start the engine. The engine should remain stopped;
- Close blade housing cover;
- Engine should remain stopped.

4. Blade brake and its circuit inspection

- Start the engine;
- Turn the tensioner handle right to engage the blade.
- Stop the engine by switching the key to “0” position. Measure the braking time.
- Braking time should always be shorter than 10 seconds. If the braking time is longer it is necessary to adjust or replace brake pads. [See Section 3.9](#)

SECTION 5 TROUBLESHOOTING GUIDE

5.1 Sawing Problems

PROBLEM	CAUSE	SOLUTION
Blades Dull Quickly	Dirty logs	Clean or debark logs, especially on entry side of the cut
	When grinding teeth, heating too much and causing teeth to soften	Grind just enough metal to restore sharpness to the teeth. Use water/coolant while sharpening blade
	Poor sharpening techniques	Make sure the tip is being sharpened completely (See Sharpener Manual)
Blades Break Prematurely	Rubber belts on blade wheels worn to a point that blade contacts metal pulley - look for shiny spots on edge of wheels	Change blade wheel belts (B-57)
	Poor sharpening techniques	See Sharpener Manual
	Tension too tight	Tension blade to recommended specifications
Blade Does Not Track Right on Drive Wheel	Cant adjustment is incorrect	Readjust
	Flat/worn belts	Replace B-57 belts
Blade Guides Do Not Spin While Cutting	Frozen bearings	Replace bearings
	Stiff bearings	Grease bearings
Blade Does Not Stop Immediately After Disengaging	Brake strap too loose	Adjust brake strap
Drive Belts Come Off Pulleys When Disengaging Blade	Brake strap too loose	Adjust brake strap
	Brake drum misaligned	Realign on drive shaft
Drive Belts Wear Prematurely or Jump	Brake strap tightened with one edge too loose and one edge too tight	Adjust brake strap
	Engine/motor and drive pulleys out of alignment	Align pulleys. See Section 5.4 Engine/Motor and Drive Pulleys Alignment.

5 Troubleshooting Guide

Sawing Problems

PROBLEM	CAUSE	SOLUTION
Boards Thick Or Thin On Ends Or Middle Of Board.	Stress in log which causes log to not lay flat on the bed.	After log has been squared, take equal cuts off opposing sides. Take a board off the top. Turn the log 180 degrees. Make a cut. Repeat, keeping the heart in the middle of the cant, and making it your last cut.
	Set in teeth.	Resharpen and reset blade.
Height Adjustment Jumps or Stutters When Moving Up or Down.	Bed rails misaligned.	Realign sawmill.
	Mast needs lubrication.	Lubricate mast track surface.
	Up/down chain improperly adjusted.	Adjust up/down chain.
Lumber Is Not Square	Vertical wear pads are too tight.	Adjust pads.
	Drive belt(s) loose.	Adjust belts.
	Vertical side supports not square to bed	Adjust side supports.
Sawdust Builds Up On Track	Blade not parallel to bed rails	Adjust bed rails parallel to blade.
	Sawdust or bark between cant and bed rails	Remove particles
	Tooth set problems	Resharpen and reset blade
Wavy Cuts	Excessive oiling	Do not oil track
	Track wipers worn	Adjust wipers to firmly contact track
Wavy Cuts	Track is sticky	Clean track with solvent and apply silicone spray
	Excessive feed	Slow feed rate
	Improperly sharpened blade (This will be the problem 99% of the time!)	Resharpen blade (See Sharpener Manual - read entire manual!)
Wavy Cuts	Blade guides improperly adjusted	Adjust blade guides.
	Sap buildup on blade	Use Water Lube.
Wavy Cuts	Tooth set problem	Resharpen and reset blade

5.2 Electrical Problems

PROBLEM	CAUSE	SOLUTION
Up/down Excessively Slow.	Up/down belt loose.	Adjust belt to be as loose as possible without slipping
	Worn/dirty contacts in drum switch.	Replace switch or remove control panel cover and clean contacts.
Up/down Or Power Feed Motors Do Not Work.	Bad key switch.	Replace key switch.
	Circuit breaker.	
	Burned-out motor.	Replace motor.
	Bad connection on battery post or loose wire.	Check for loose wire or terminal connections.
	Up/down motor relay damaged.	Have a qualified electrician replace the relay.
	Up/down motor is damaged.	Have a qualified electrician replace the up/down motor.
	One phase lacks.	Check circuit breakers in the connectors.
	Motor thermal protector started to work.	Let the motor cool and then reset the thermal protector.
	Speed switch circuit overloaded.	Turn off the power bad let the motor cool. Turn the power back on.
	Power feed is overheated.	Turn off the power and let the motor cool. Turn the power back on.
Up/Down Or Power Feed Switches Remain Engaged When Switch Is Released.	Short circuit in speed switch motor system.	Have a qualified electrician remove the short circuit.
	Worn or dirty contacts in drum switch.	Manually move the power feed or up/down switch back to neutral or "off" position. Replace drum switch or remove control panel cover and clean and lubricate contacts NOTE: Use only contact grease supplied by Wood-Mizer.
	Drum switch spring broken.	Manually move the power feed or up/down switch back to neutral or "off" position. Replace drum switch spring.

5 Troubleshooting Guide

Power Feed Problems

Up/Down Or Power Feed Motors Overheat And Loose Power.	System overload or bind occurred.	Correct problem. See Section 5.3 Power Feed Problems. Allow motor to cool before restarting.
	Normal operation factors exceeded (e.g.: up/down control jockeyed excessively).	Allow motor to cool before restarting.
Everything Works And Then Cuts Out - Works Again.	Bad fuse, or ground connection.	Check and tighten connections.
Nothing Works Electrically.	Blown fuse.	Replace.

5.3 Power Feed Problems

PROBLEM	CAUSE	SOLUTION
Power Feed Is Jerky At Low Speeds Or Does Not Move Until Speed Is Above Halfway Mark.	Drum switch is dirty.	Clean drum switch and lubricate with contact grease supplied by Wood-Mizer.
	Drum switch contacts are bad	Check that contacts are in good condition and positively close circuit.
	Speed switch is worn.	Replace the speed switch.
	Speed switch is blocked.	Turn off the power for 20 seconds and turn it back on.
Power Feed Is Jerky, But Power Feed Motor Runs Properly At All Speeds.	Problem is mechanical.	Refer to the Mechanical Test.

PROBLEM	CAUSE	SOLUTION
Power Feed Motor Overheats.	Middle track oiler is dragging.	Clean middle track oiler and lubricate with 30-weight oil or ATF (Automatic Transmission Fluid) such as Dexron II. Allow motor to cool before restarting.
	Ground is not level.	Level mill with carpenter's level. Allow motor to cool before restarting.
	Track roller bearing drag is excessive.	Lubricate bearings; Replace tight bearings. Allow motor to cool before restarting.
	Lower track rollers are not aligned properly.	Check stop block clearance from lower bed rail. Allow motor to cool before restarting.
	Chain is dragging.	Make sure chain is centered on cam follower bearing; Clean and lubricate chain; Adjust chain tension. Allow motor to cool before restarting.
	Chain is improperly tensioned.	Adjust chain tension. Allow motor to cool before restarting.
	Power feed is binding.	Adjust belt tension; Check condition of belt, pulleys, bearings, and sprocket; Check motor for ground fault. Allow motor to cool before restarting.
	Saw head load is excessive.	Avoid unnecessary modifications to saw heads that would give them extra weight. Allow motor to cool before restarting.
	Blade is dull or improperly set.	Use proper blade maintenance procedures (See Sharpener or Toothsetter manual). Allow motor to cool before restarting.

5.4 Engine/Motor and Drive Pulleys Alignment

1. Install the drive belt.
2. Use a straight edge to align the engine/motor pulley to the drive pulley. Also check that the engine pulley is within 1/8" square with the drive pulley. Loosen the engine mounting bolts and rotate the engine if necessary.
3. Check front-to-back movement of the engine does not exceed 6,5 mm 1/4". Tighten the motor mount U-bolts if necessary.
4. Adjust the drive belt tension to 11mm deflection with 7,2 kg. of force.
5. Recheck the pulley alignment and engine squareness with the clutch handle engaged. Adjust if necessary.
6. Adjust the drive belt support to 6mm from the belt while engaged.

SECTION 6 SAWMILL ALIGNMENT

6.1 Pre-Alignment Procedures

The Wood-Mizer sawmill is factory aligned. This section includes instructions on how to realign the sawmill completely. Be scrupulous when performing all alignment steps as sawmill alignment determines the accuracy of your cuts. The alignment procedure should be performed approximately every 1500 hours of operation (sooner if you regularly transport the sawmill over rough terrain).

Routine Alignment Procedure:

1. Install and track the blade ([See Section 6.3](#)).
2. Check the angle of the blade in relation to the bed rails and adjust the lower track rollers if necessary ([See Section 6.18](#)).
3. Check and adjust the vertical alignment of the blade guide arm ([See Section 6.7](#)).
4. Check and adjust the horizontal alignment of the blade guide arm ([See Section 6.10](#)).
5. Check and adjust the vertical angle of the blade guides ([See Section 6.13](#)).
6. Check and adjust the horizontal angle of the blade guides ([See Section 6.15](#)).
7. Check and adjust the spacing between the blade guide flange and the back of the blade ([See Section 6.14](#)).
8. Check and adjust the horizontal angle of the side supports ([See Section 6.16](#)).
9. Check and adjust the vertical angle of the side supports ([See Section 6.17](#)).
10. Check that the blade height scale accurately displays the actual distance from the bottom of the blade to the bed rails and adjust if necessary ([See Section 6.19](#)).

Complete Alignment Procedure:

Perform all steps in this section to completely realign the sawmill.

6.2 Frame Setup

Stationary sawmills should be setup on firm, level ground before proceeding with alignment.

6.3 Blade Installation And Alignment

See **Figure 6-1**. Install a blade and apply the appropriate tension. Blade tension is adjusted with the tension handle shown below.

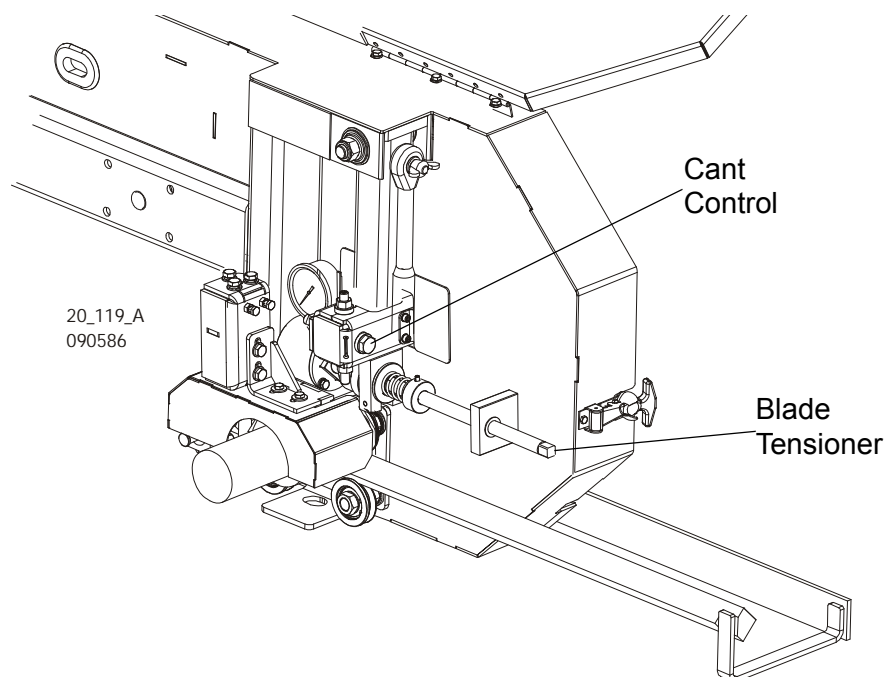

FIG. 6-1

Electric Sawmills:

1. Turn the key switch to the "H" position.

H

2. Open the blade housing cover.
3. Manually spin one of the blade wheels until the blade positions itself on the blade wheels.

Gas Sawmills:

1. Turn the key switch to the "0" position and remove the key.
2. Open the blade housing cover.

3. Release the locking pin. To do this, pull it outward and rotate.
4. Push the clutch lever up lightly so that the locking pin drops down into the hole. At this position of the lever the blade brake is released and the drive belt is loosened.

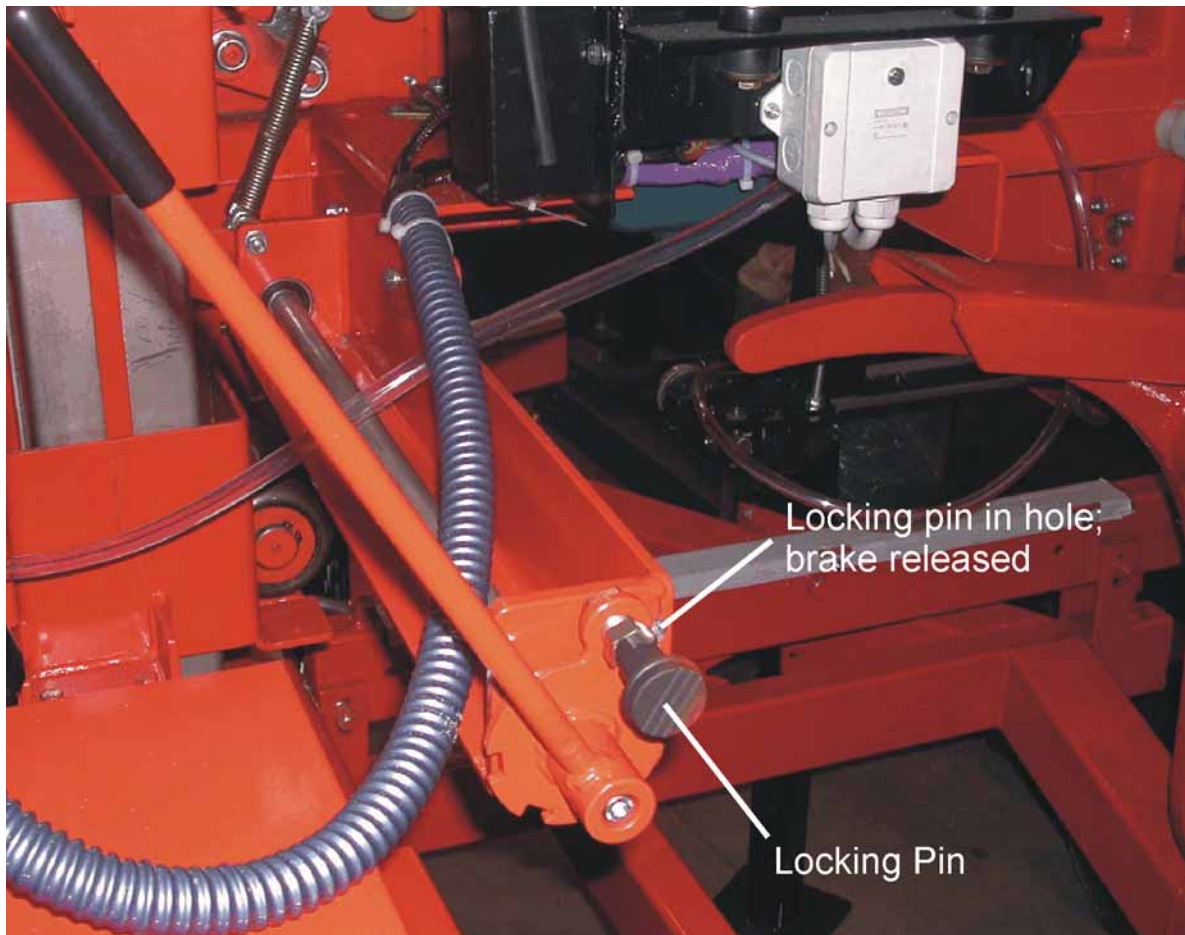

FIG. 6-1

5. Spin one of the blade wheels by hand until the blade positions itself on the blade wheels.

Check the vertical alignment of the idle-side blade wheel. The gullet of the blade should ride the same distance from the front edge of the wheel at the top and bottom of the wheel. If it does not, loosen and tighten the appropriate adjustment screws on the wheel shaft.

See Figure 6-2. The blade wheels should be adjusted so that the gullet of 1 1/4" blades rides 3.0 mm (0.12") out from the front edge of the wheels (± 1.0 mm [0.04"]). The gullet of 1 1/2" blades should ride 4.5 mm (0.18") from the front edge of the wheels (± 1.0 mm

[0.04"]). Do not let the teeth ride on the belt.

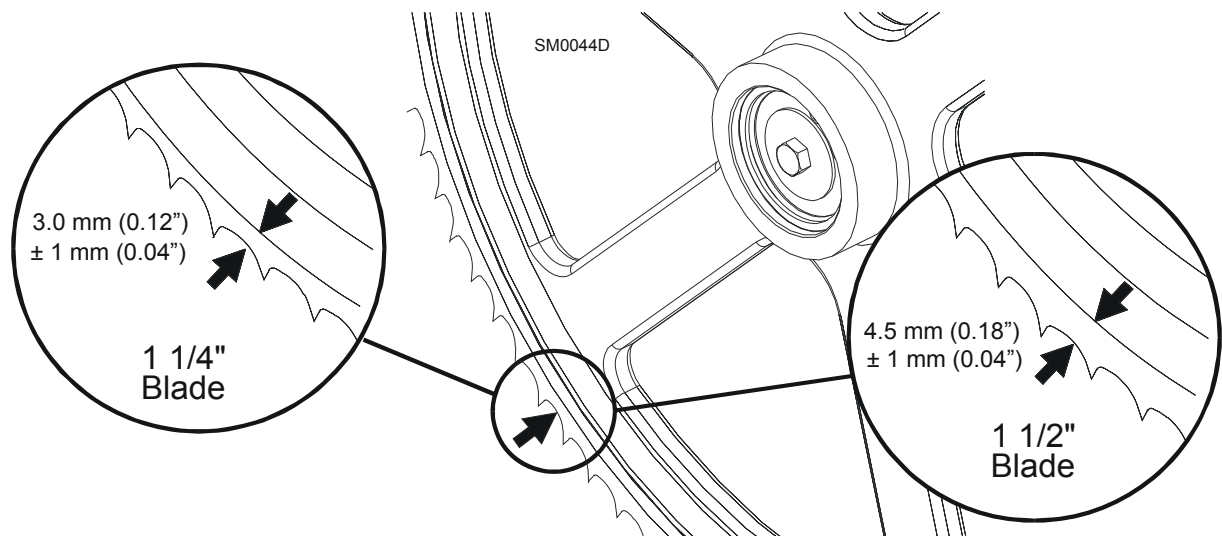

FIG. 6-2

To adjust where the blade travels on the idle-side blade wheel, use the cant control shown in **Figure 5-1**.

To move the blade out on the blade wheel, turn the cant adjustment screw clockwise. To move the blade in on the blade wheel, turn the screw counterclockwise.

Some adjustment in blade tension may be needed to compensate for adjustments made with the cant control.

Adjustment with the cant control is usually all that is required to track the blade properly on both blade wheels. The drive-side blade wheel will usually not have to be adjusted. If necessary, the drive-side wheel can be adjusted as follows:

Locate the nuts and the clamping screws located on the drive-side of the cutting head. If the blade is too far forward on the wheel, turn the screw located on the inside of the head counterclockwise and turn the screw located on the outside of the head clockwise. Make sure to tighten the nuts against the shaft housing when adjustment is complete.

6.4 Blade Wheel Alignment

The blade wheels should be adjusted so they are level in the vertical and horizontal planes. If the blade wheels are tilted up or down, the blade will want to travel in the tilted direction. If the blade wheels are tilted horizontally, the blade will not track properly on the wheels.

1. Use the blade guide alignment tool to check the vertical alignment of each blade wheel. Attach the tool to the blade near the inner blade guide mount. Be sure the tool does not rest on a tooth or burr, and is lying flat against the bottom of the blade.

See Figure 6-3.

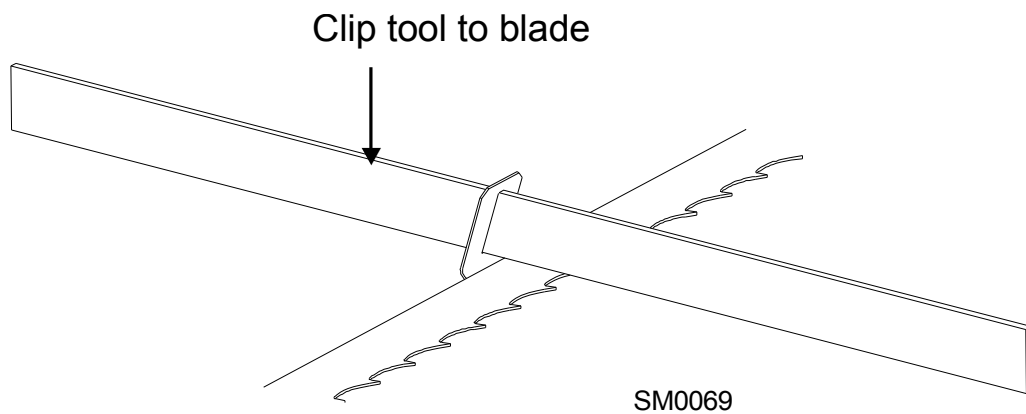

FIG. 6-3

2. Move the saw carriage so the front end of the tool is positioned over the first bed rail. Measure from the bottom of the tool to the top surface of the bed rail.
3. Move the saw carriage so the rear of the tool is positioned over the bed rail. Again, measure from the bottom of the tool to the bed rail.
4. If the two measurements differ by more than (± 1.5 mm), adjust the vertical tilt of the drive-side blade wheel.

See Figure 6-4. Use the vertical adjustment screws to adjust the drive-side blade wheel. To tilt the wheel, loosen the top adjustment screw one quarter turn. Loosen the jam nut on the bottom adjustment screw and tighten the screw. Tighten the top and bottom jam nuts.

To tilt the wheel, loosen the bottom adjustment screw one quarter turn. Loosen the jam nut on the top adjustment screw and tighten the screw. Tighten the top and bottom jam nuts.

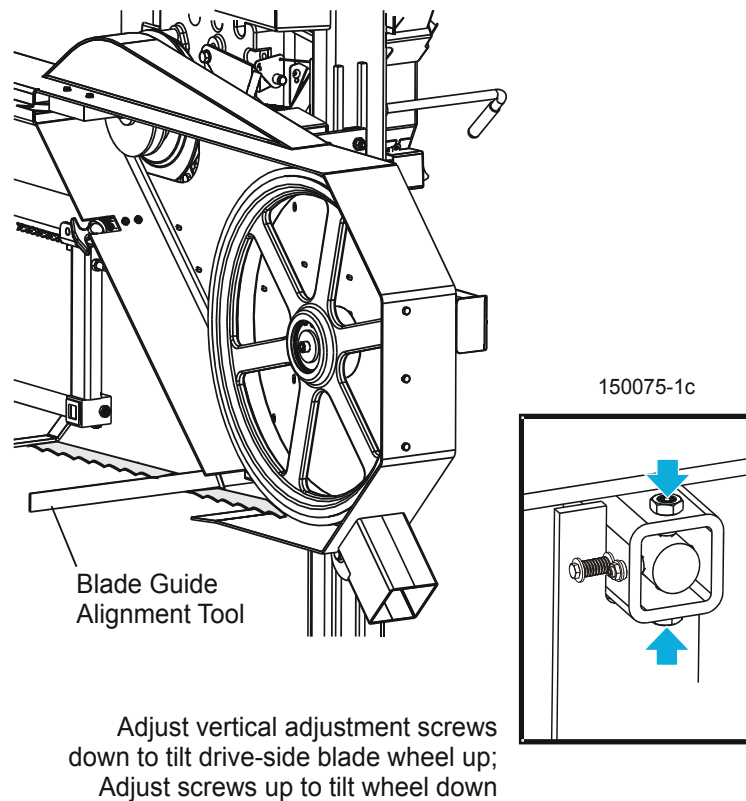

FIG. 6-4

5. Recheck the vertical tilt of the drive-side blade wheel with the blade guide alignment tool. Readjust the blade wheel as necessary until the front and rear of the tool are the same distance from the bed rail (± 1.5 mm).
6. Remove the tool from the blade and reattach it near the outer blade guide assembly.
7. Measure from the tool to the bed rail at both ends of the tool. If the measurements at the front and rear ends of the tool differ by more than (± 1.5 mm), adjust the vertical tilt of the idle-side blade wheel.

See Figure 6-5. Use the vertical adjustment screws to adjust the idle-side blade wheel. To tilt the wheel up, loosen the bottom adjustment screw one quarter turn. Loosen the jam nut on the top adjustment screw and tighten the screw. Tighten the top and bottom jam nuts.

To tilt the wheel down, loosen the top adjustment screw one quarter turn. Loosen the jam nut on the bottom adjustment screw and tighten the screw. Tighten the top and bottom jam nuts.

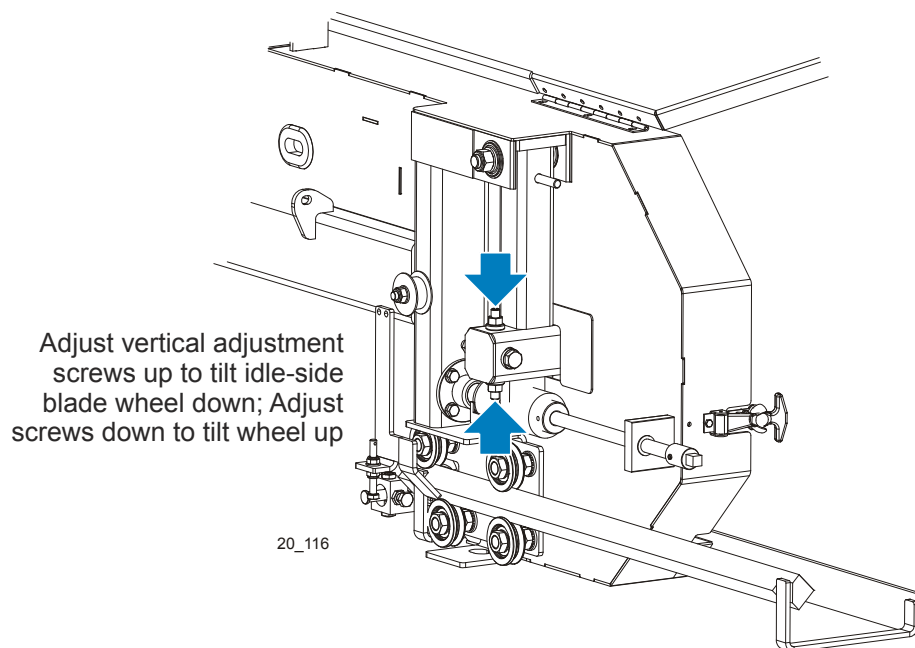

FIG. 6-5

8. Recheck the vertical tilt of the idle-side blade wheel with the blade guide alignment tool. Readjust the blade wheel as necessary until the front and rear of the tool are the same distance from the bed rail.
9. Check the position of the blade on the idle-side blade wheel.

See Figure 6-6. The horizontal tilt of the blade wheel should be adjusted so that the gullet of an 1-1/4" blade is 3.0 mm out from the front edge of the wheel (± 1.0 mm).

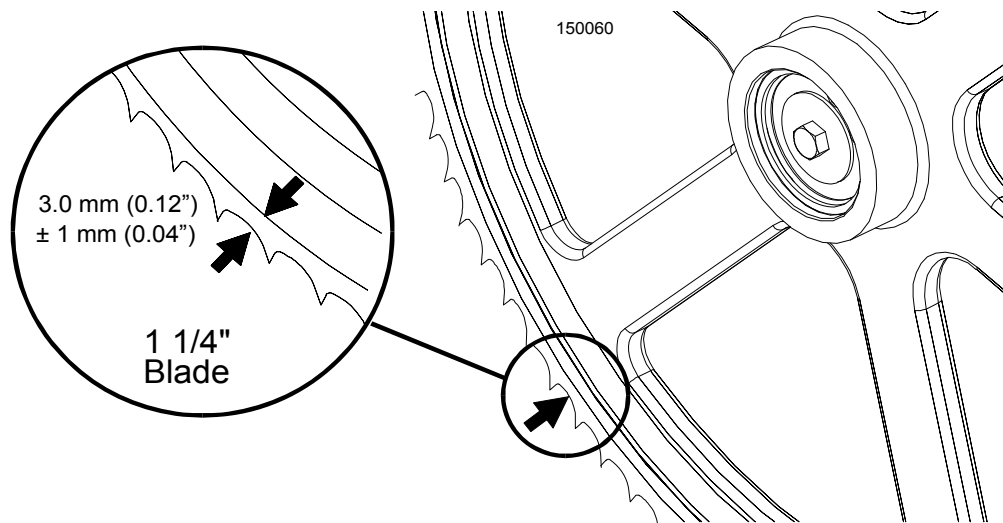

FIG. 6-6

See Figure 6-7. Use the cant control adjustment to adjust the idle-side blade wheel. If the blade is too far forward on the wheel, turn the cant control counterclockwise. If it is too far back on the wheel, turn the cant control clockwise.

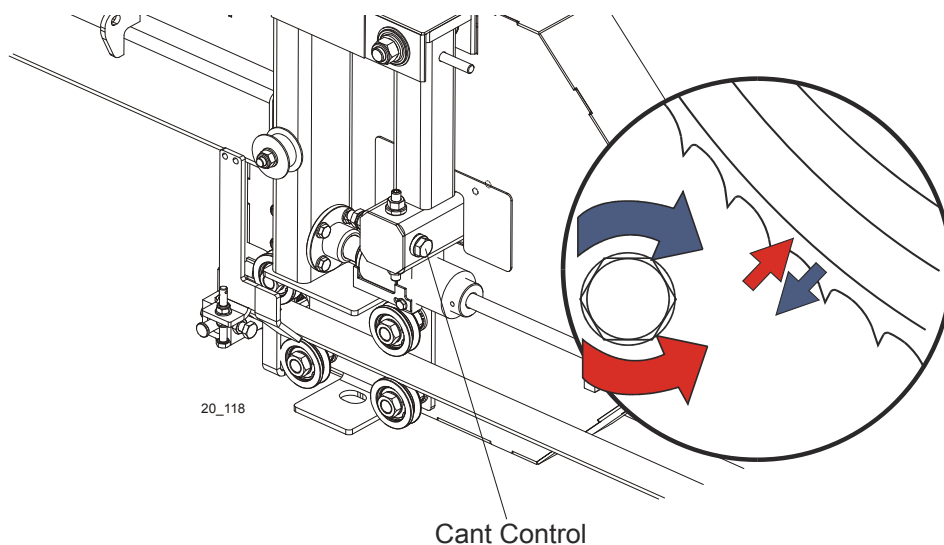

FIG. 6-7

10. Check the position of the blade on the drive-side blade wheel. The blade should be positioned on the wheel as described for the idle-side blade wheel. Adjust the drive-side blade wheel if necessary.

See Figure 6-8. Use the horizontal adjustment screw to adjust the drive-side blade wheel. Loosen the jam nut on the adjustment screw. Loosen adjustment screw to move blade out on wheel. Tighten adjustment screw to move blade in on wheel. Tighten the jam

nut.

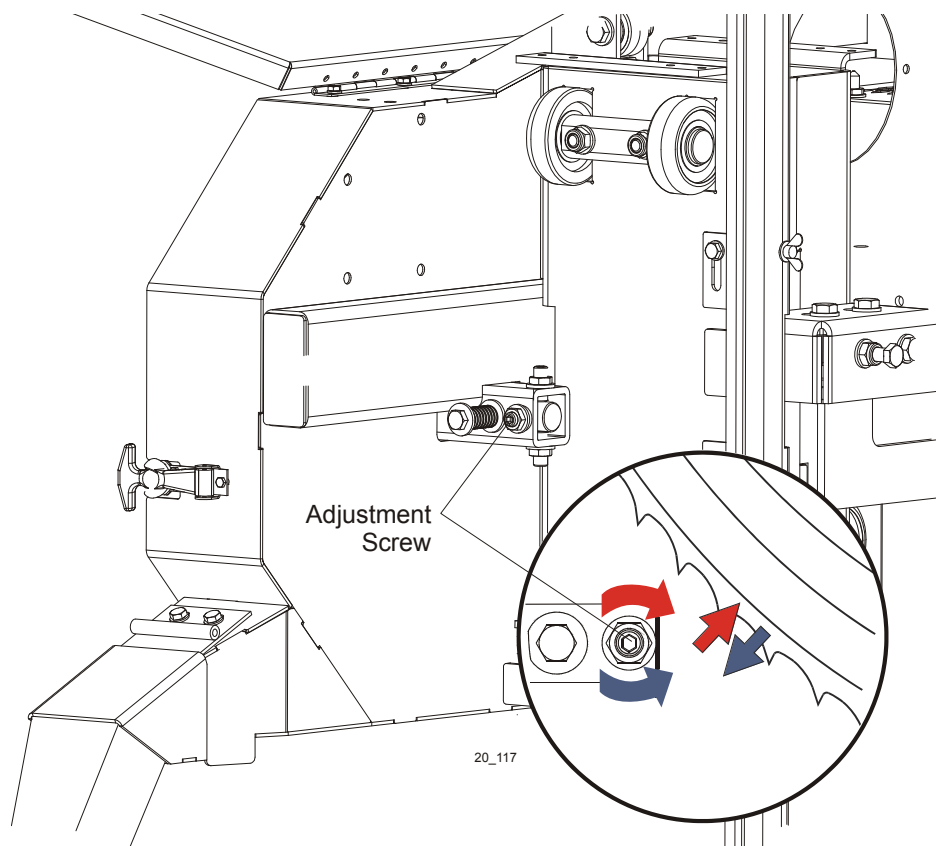

FIG. 6-8

6.5 Adjusting The Lower Track Rollers

See **Figure 6-9**. Making these adjustments correctly will give you square cuts and accurate dimensions across the width of your boards.

1. Using the power feed switch, move the saw carriage so that the blade is positioned over the front bed rail.
2. Check the lower rollers. Both rollers should touch the rail so that you cannot spin them by hand. If the rollers are not adjusted evenly and you can spin either one, loosen the stop bolt and adjust the adjustment nuts until the roller cannot be spun by hand. Check the other roller and adjust if necessary. Adjust both rollers until each evenly supports the carriage and you cannot spin either by hand.
3. Move the carriage forward until the blade is positioned over the rear bed rail. Repeat the step #2 until the lower rollers are adjusted properly at the front and rear of the sawmill.

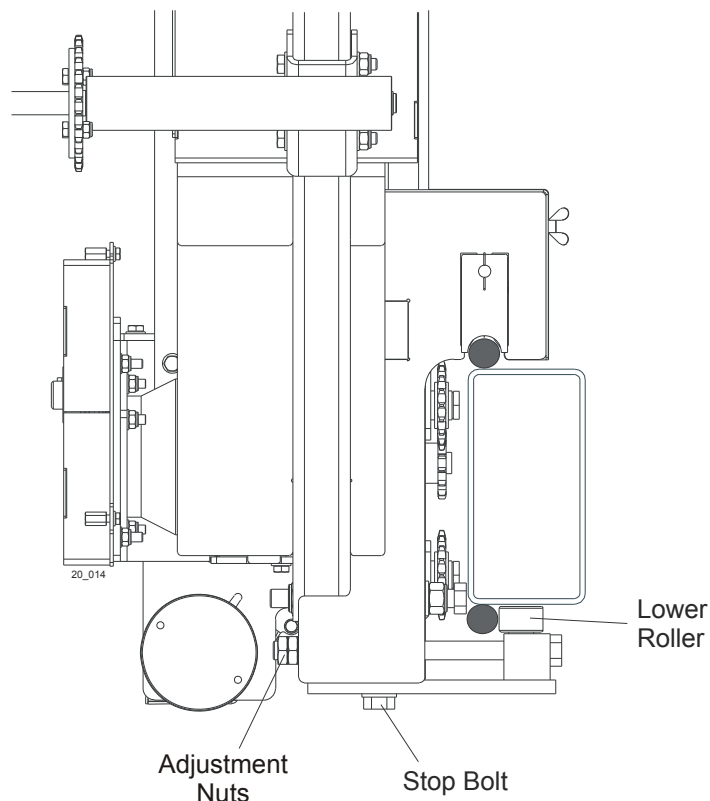

FIG. 6-9

4. Remove the blade guides, or adjust them so that they do not touch the blade.
5. Open the adjustable blade guide arm to within 1/2" (15 mm) of full open.
6. Move the carriage back to the front bed rail. Raise the cutting head until the bottom of the

blade is 400 mm above the outside of the bed rail support by actual measurement with a tape or ruler.

See Figure 6-10.

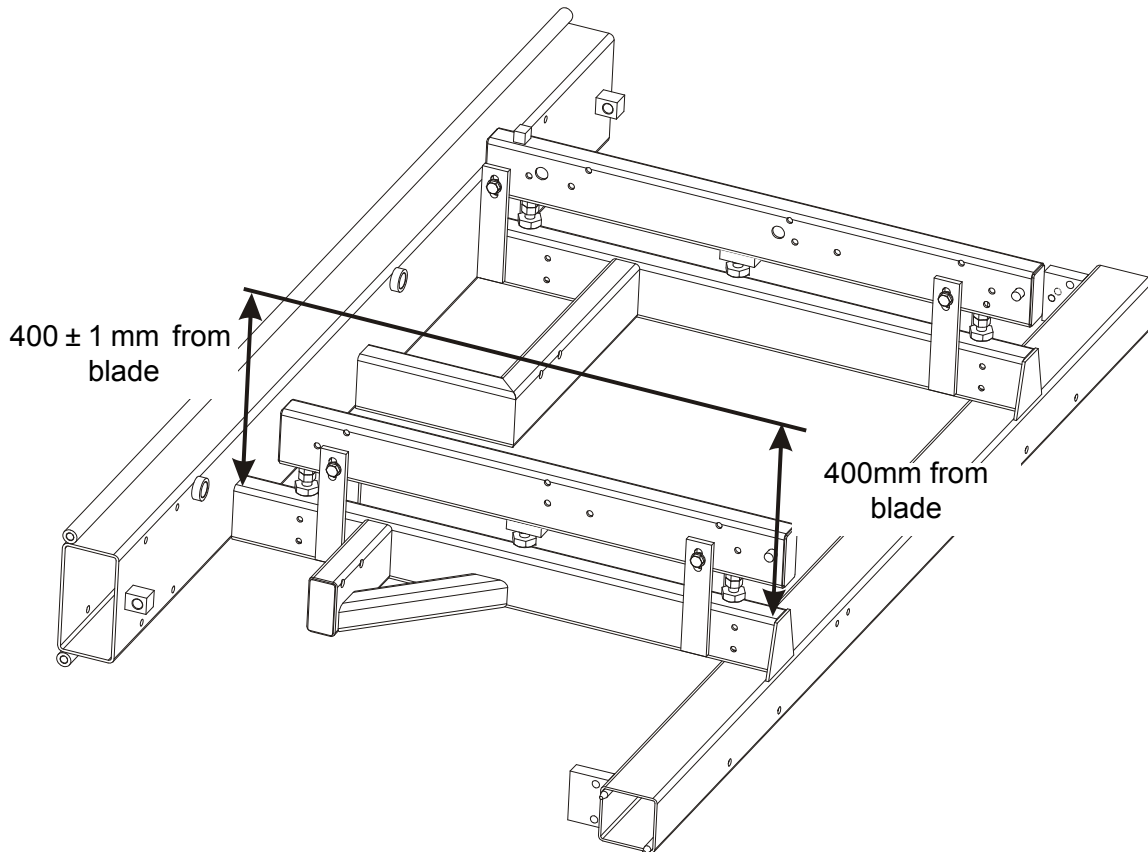

FIG. 6-10

7. Check the distance to the blade at the inside of the bed rail support. Both measurements should be equal within (± 1.0 mm [0.04"]).
8. Using the adjustment nuts adjust the lower rollers to tilt the cutting head until the blade is parallel (± 1.0 mm [0.04"]) to the bed rail support.

NOTE: Adjustments of the lower track rollers change the angle between the cutting head and sawmill bed rails. Only small adjustments of the lower track rollers should ever be needed.

9. After the lower track rollers are adjusted properly, adjust the stop screw. Tighten the screw until it touches the main bed tube. Then, back the screw off 1/2 turn. The distance from the rail should be 1.0 mm [0.04"].



CAUTION! It is important that the stop screw is properly adjusted to secure the carriage on the track rails. Failure to

properly adjust the stop screw can cause cutting head damage, especially during mill transportation.

See Figure 6-11.

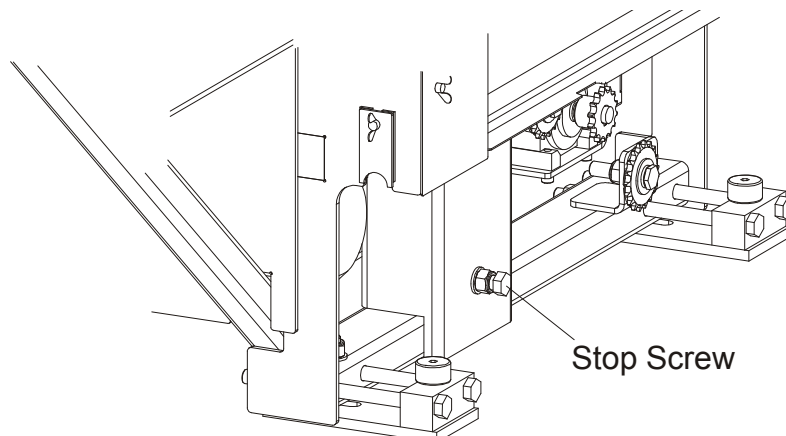

FIG. 6-11

6.6 Adjusting Bed Rails To The Blade

1. Move the cutting head so the blade is positioned over the center of the front main bed rail.
2. Measure the distance between the bottom of the blade and the bed rail at each end of the bed rail. The bed rail should measure 15" (375 mm) (+ 1.0 mm on the outer end) from the blade at each end of the rail.

See Figure 6-12.

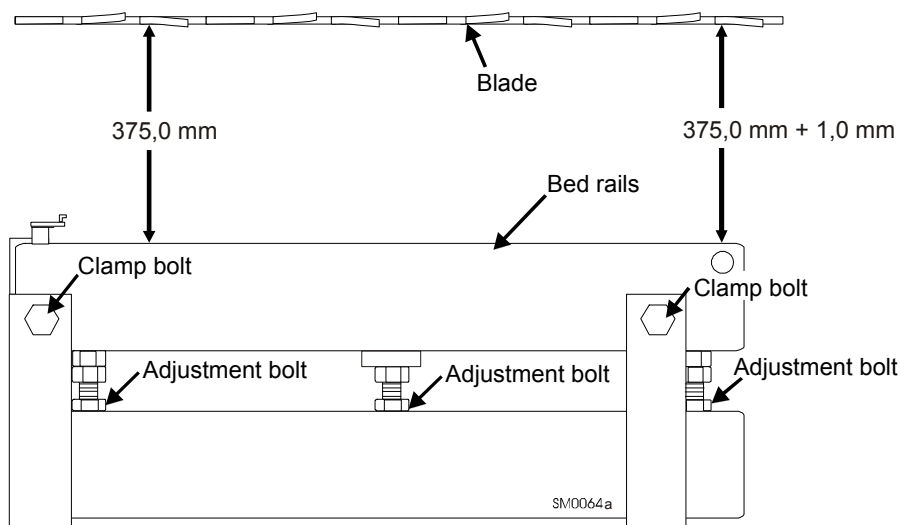

FIG. 6-12

3. Loosen the bed rail clamping bolts and turn the adjustment bolts to move the bed rails to the blade if necessary.
4. Retighten the clamping bolts and adjustment bolts.
5. Without adjusting the cutting head height, check the four main bed rails. Adjust them so that all measure the same distance from the blade at both ends of the bed rail.

6.7 Blade Guide Arm Vertical Adjustment

1. Move the cutting head so that the blade guide arm is directly over a bed rail.
2. Adjust the blade guide arm out to within 1/2" (15 mm) of full open.
3. Measure from the top of the bed rail to the arm.

See Figure 6-13.

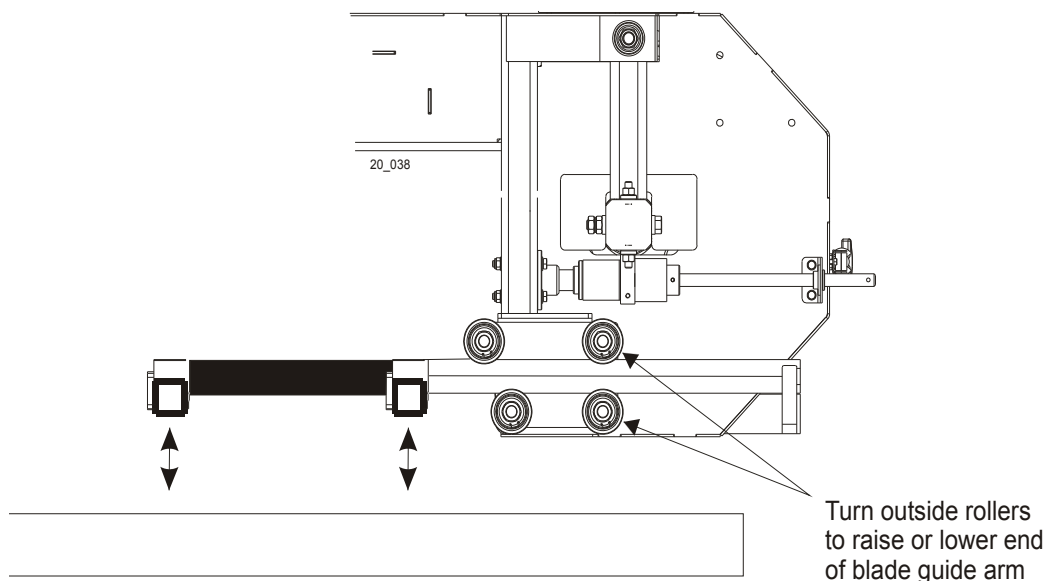

FIG. 6-13

4. Adjust the blade guide arm in to within 1/2" (15 mm) of full closed. Measure again from the top of the bed rail to the arm.
5. Adjust the arm so that the measurement from the top of the bed rail to the arm in the closed position is the same as the measurement from the top of the bed rail to the arm in the open position.

If the arm is too low in the closed position, loosen the lower outside roller and tighten the upper outside roller (See point 6.)

6. The rollers are mounted on cam bolts that raise or lower the arm when turned.

To adjust the rollers, locate the cam bolt inside the housing and turn until the arm is lowered or raised as needed. Recheck the arm in both the open and closed positions. Repeat adjustments until the arm is the same distance from the bed rail in the open and closed position.

- The blade guide arm should be snug, but not too tight, in the rollers. You should be able to move it in and out with firm hand pressure. There should be no side-to-side play.

6.8 Blade Guide Arm Feed Chain Adjustment

- Arm and motor sprockets must be in line (see figure below). If not, loosen the set screws and adjust the arm motor placement. Next, tighten the set screws.

If the motor sprocket (1) is not parallel to the blade guide arm sprockets (2), the drive assembly may be adjusted by turning it at a small angle around the indicated point.

To adjust, loosen (3) bolts and use (4) bolts.

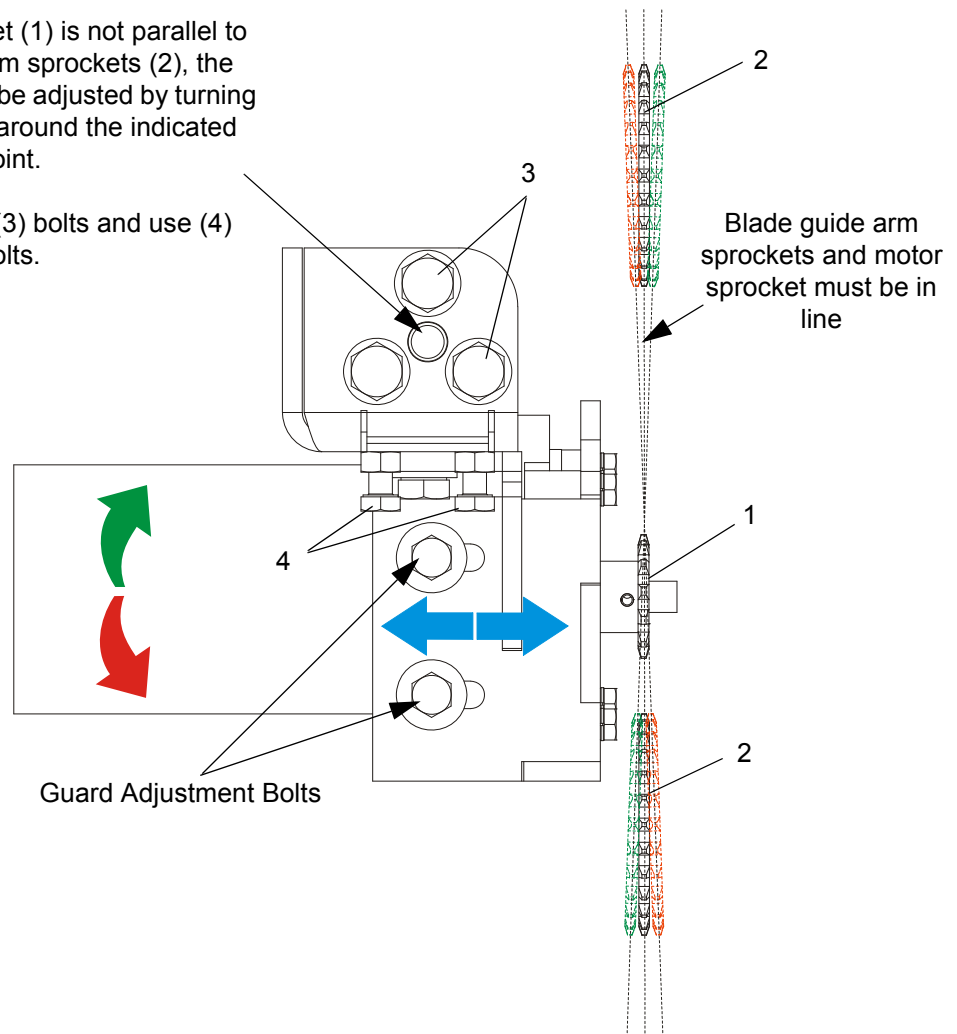

FIG. 6-13

- Check the blade guide arm chain tension. Tighten the chain if is too loose.

See Figure 6-14. Loosen the two set screws. Move the bracket with motor down to tighten the chain, move it up to loosen. Next tighten the set screws.

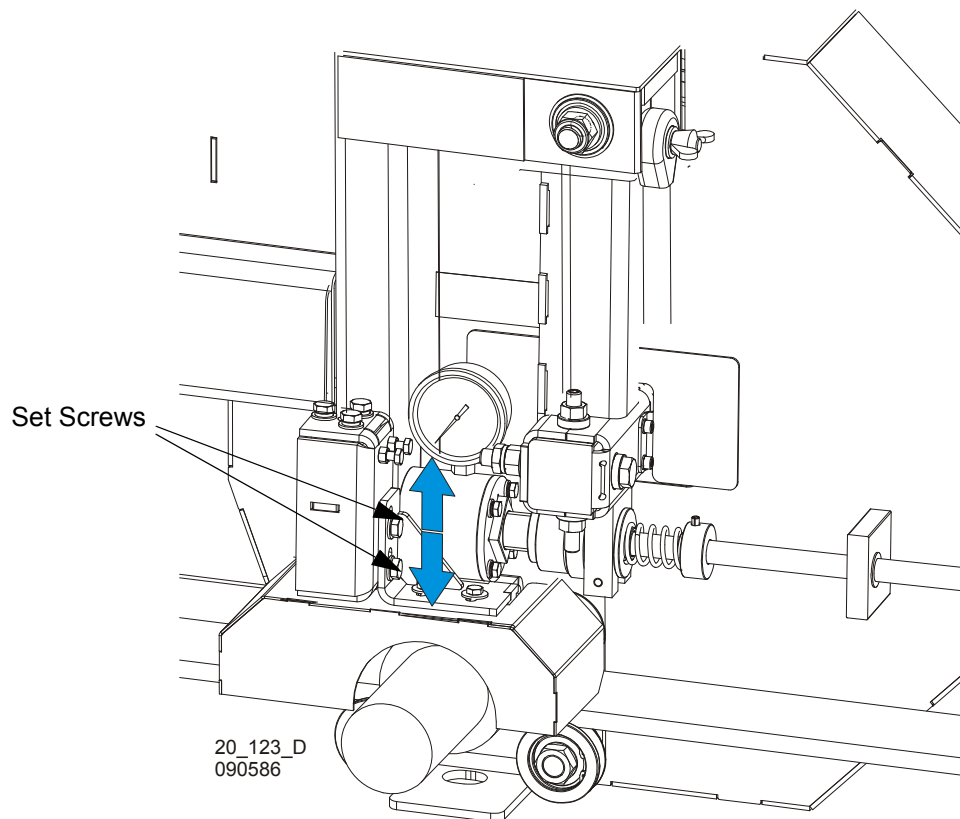

FIG. 6-14



CAUTION! Do not overtension the chain. It will cause premature chain and sprockets wear.

6.9 Saw Head Backlash Removal

Check the saw head for backlash every 200 hours of operation. If necessary, remove the backlash.

See Figure 6-15. To check if the backlash is present, grasp the outside part of the saw head and move it as shown in the figure below. To remove the backlash, perform the following steps:

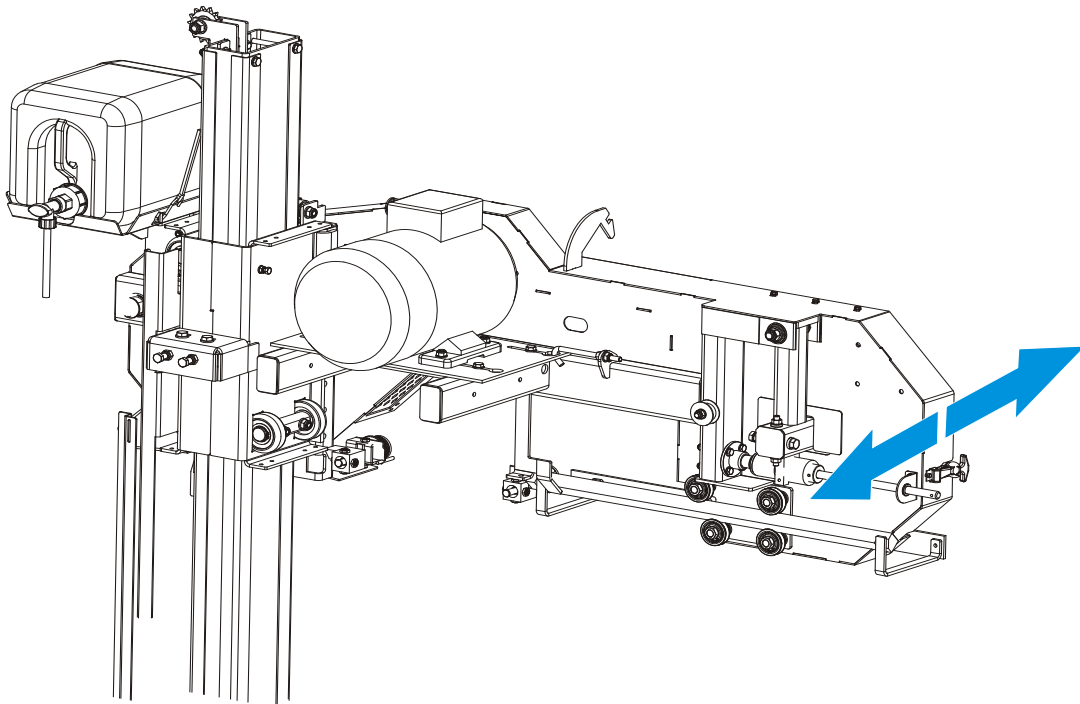

FIG. 6-15

1. Loosen the nuts on the adjustment bolts and the set screws shown in Figure 6-15, adjust the mast guide rollers as shown in Figure 6-15.

2. Tighten the two adjustment bolts evenly to remove the backlash.

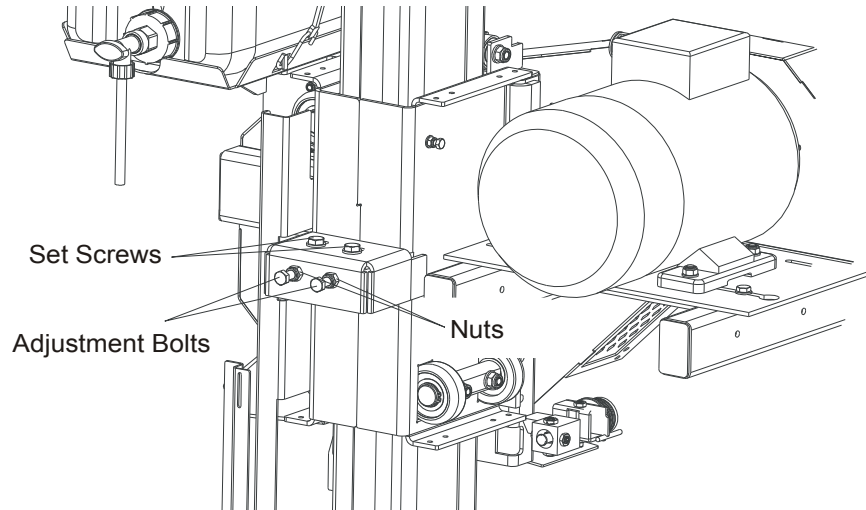

FIG. 6-15

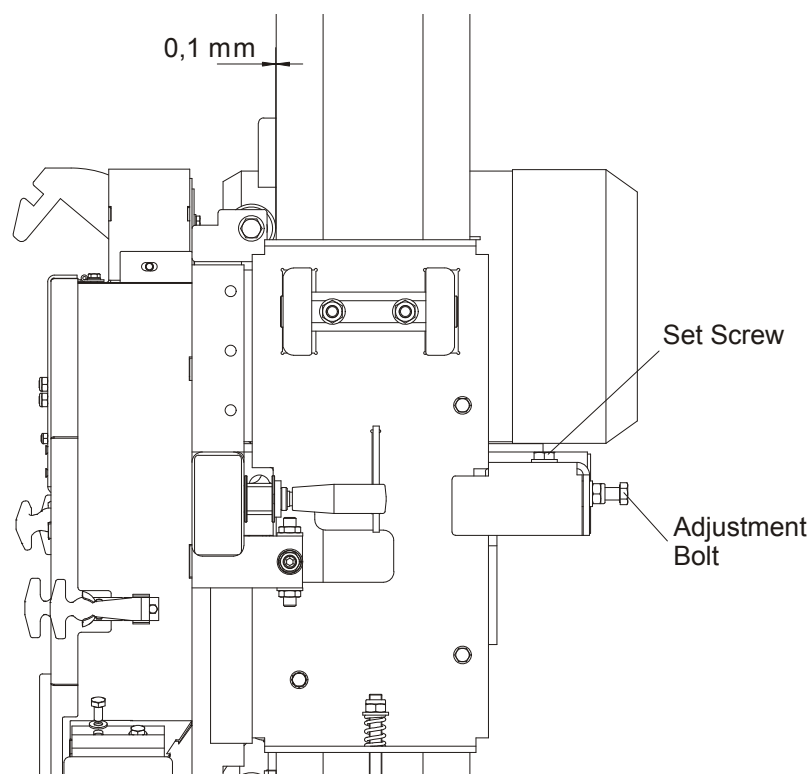

FIG. 6-15

3. Tighten the set screws and the nuts.



CAUTION! Do not overtighten the adjustment bolts.
Damage to the up/down system may result.

6.10 Blade Guide Arm Horizontal Adjustment

1. Put the blade guide assembly back in the arm (if you took it out). Put the assembly back so that the flanged collar on the roller is about 3.0 mm (0.04") from the back of the blade when the arm is 15 mm (0.6") from full open.
2. Close the throat to within 15 mm (0.6") from fully closed. Check to see that the flange is the same distance from the back of the blade.

See Figure 6-16.

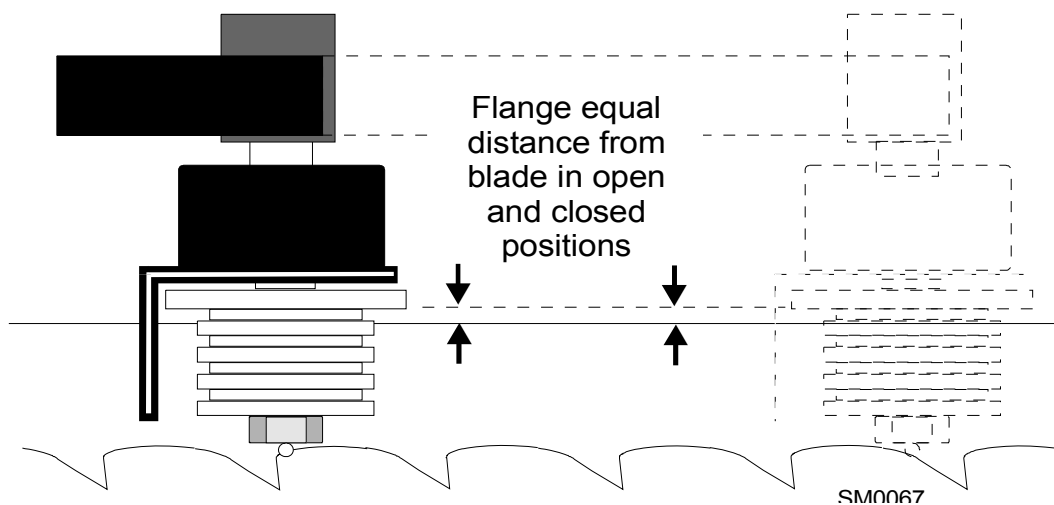

FIG. 6-16

3. If adjustment is needed, the guide rollers can be adjusted in or out on the threaded mounts to open or close the gap.

See Figure 6-17.

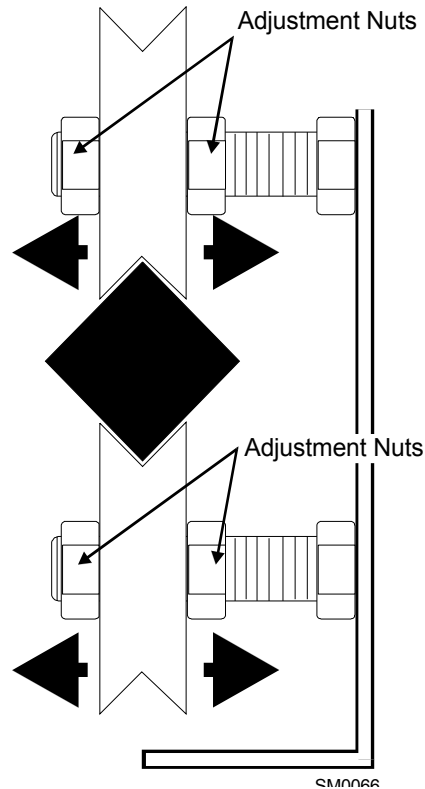

FIG. 6-17

4. Adjusting the outside two rollers (furthest from the arm motor) inward will cause the flange to move away from the blade.
5. Adjusting the two outside rollers outward will cause the flange to move toward the blade.
6. Adjust until the roller flange is the same distance from the back of the blade in the open and closed position.

6.11 Aligning the Blade Guides

Each Wood-Mizer sawmill has two blade guide assemblies that help the blade maintain a straight cut. The two blade guide assemblies are positioned on the cutting head to guide the blade on each side of the material being cut.

One blade guide assembly is mounted in a stationary position on the drive side of the cutting head. This assembly is referred to as the "inner" blade guide assembly.

The other blade guide assembly is mounted on the idle side of the cutting head. It is referred to as the "outer" assembly and is adjustable for various widths of materials to be processed.

Blade guide alignment includes four steps:

- Blade Deflection
- Blade Guide Vertical Tilt
- Blade Guide Flange Spacing
- Blade Guide Horizontal Tilt

Perform the blade guide alignment after you have aligned the blade on the wheels and adjusted the blade and blade guide arm parallel to the bed rails. After blade guide alignment, check the scale indicator to make sure it is adjusted properly. ([See Section 6.19.](#))

NOTE: During blade guide alignment, remove the blade guide adjusting screws and apply a lubricating oil such as 10W30 or Dexron III to each screw. This will prevent the screws and threaded holes from corroding and make screw adjustments easier.

6.12 Blade Deflection

Perform the following steps to achieve proper blade deflection with the blade guides.

1. Raise the carriage until the blade is 375 mm (15") above a bed rail. Measure the actual distance with a tape from the top of the rail to the bottom of the blade.
2. Install the blade guides. Make sure the two set screws shown are threaded into the blade guide shaft until they touch each other.

See Figure 6-18.

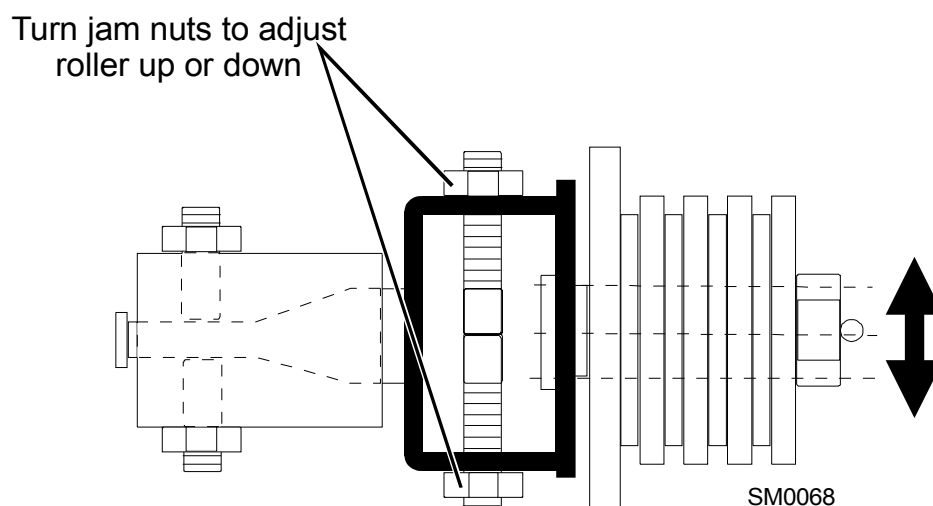

FIG. 6-18

3. Loosen the bottom jam nut and tighten the top jam nut until the blade guide deflects the blade down 6.0 mm (0.24").
4. Repeat for the other blade guide.

NOTE: Be sure that the blade guide touches the blade in both guide assemblies. The outer blade guide should be checked with the arm all the way in and all the way out.

6.13 Blade Guide Vertical Tilt Adjustment

Check that the blade guide does not tilt the blade up or down. A Blade Guide Alignment Tool (BGAT) is provided to help you measure the vertical tilt of the blade.

1. Open the blade guide arm 15 mm (0.6") from full open.
2. Clamp the alignment tool on the blade. Position the tool close to a blade guide roller. Be sure the tool does not rest on a tooth or burr, and is lying flat on the blade.

See Figure 6-19.

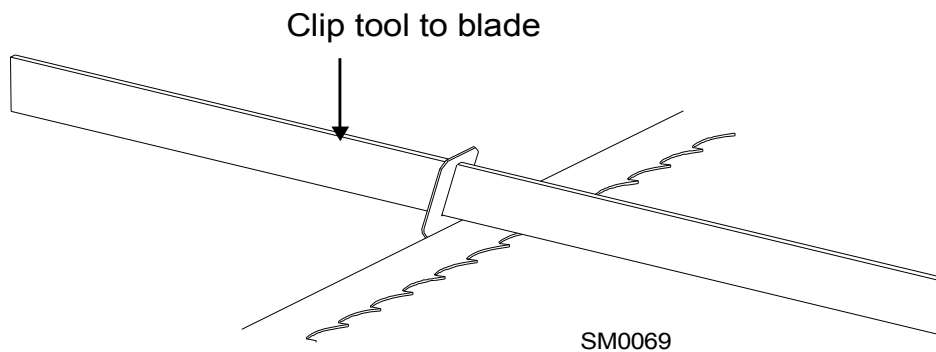

FIG. 6-19

3. Measure the distance from the bed rail to the bottom of the tool.
NOTE: If the sawmill is equipped with stainless steel bed rail covers, be sure to measure from the blade guide alignment tool to the top surface of the cover rather than the bed rail tube.
4. Move the carriage so that the front end of the tool is positioned above the bed rail.
5. Measure the distance from the bed rail to the bottom edge of the tool.
6. Loosen one set screw at the side of the blade guide assembly.
7. Use the set screws shown to tilt the blade guide until the measurement from the bed rail to the tool equals the first measurement taken at the center of the tool.

See Figure 6-20.

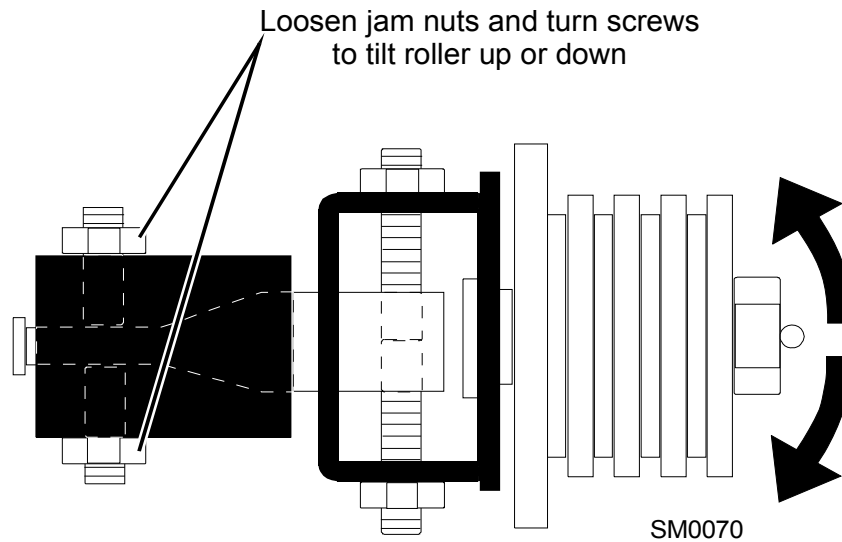

FIG. 6-20

8. Move the carriage forward so the back end of the tool is over the bed rail.
9. Use the set screws shown to adjust the blade guide tilt until the measurement from the bed rail to the tool equals the other two measurements taken.
10. Move the tool close to the other blade guide and repeat the previous steps.

NOTE: If major adjustments to blade guide tilt were made, measure the distance between the blade and the bed rails again to ensure the correct 6.0 mm (0.24") blade guide deflection. Adjust if necessary.

6.14 Blade Guide Spacing

HINT: When adjusting blade guide spacing, loosen the top set screw and one side set screw only. This will ensure horizontal and vertical tilt adjustments are maintained when the set screws are retightened.

1. Adjust the inner blade guide so the blade guide flange is approximately 1.5 – 3.0 mm (0.06 - 0.12") from the back of the blade.
2. Loosen one side and one top set screw shown. Tap the blade guide forward or backward until properly positioned.

See Figure 6-21.

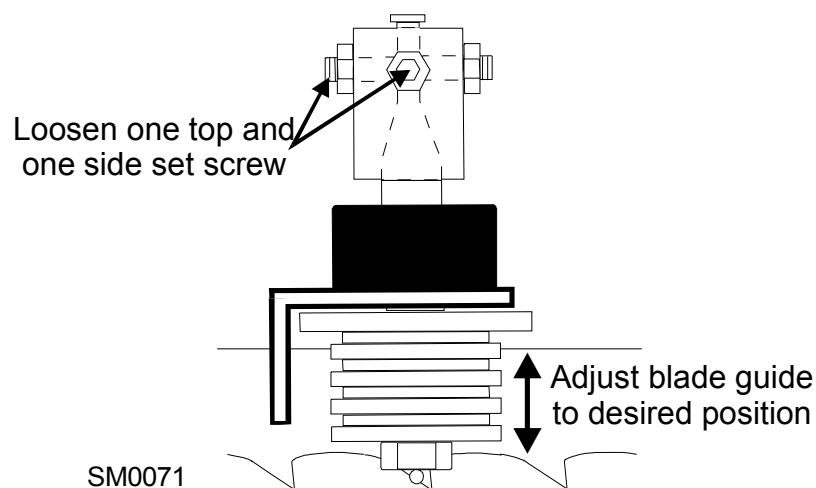

FIG. 6-21

3. Retighten the two set screws.
4. Adjust the outer blade guide in the same way so the blade guide flange is approximately 1.5 – 3.0 mm (0.06 - 0.12") from the back of the blade.

6.15 Horizontal Tilt Adjustment

1. Finally, both blade guides must be tilted horizontally. Adjust the blade guide arm halfway in.

See Figure 6-22.

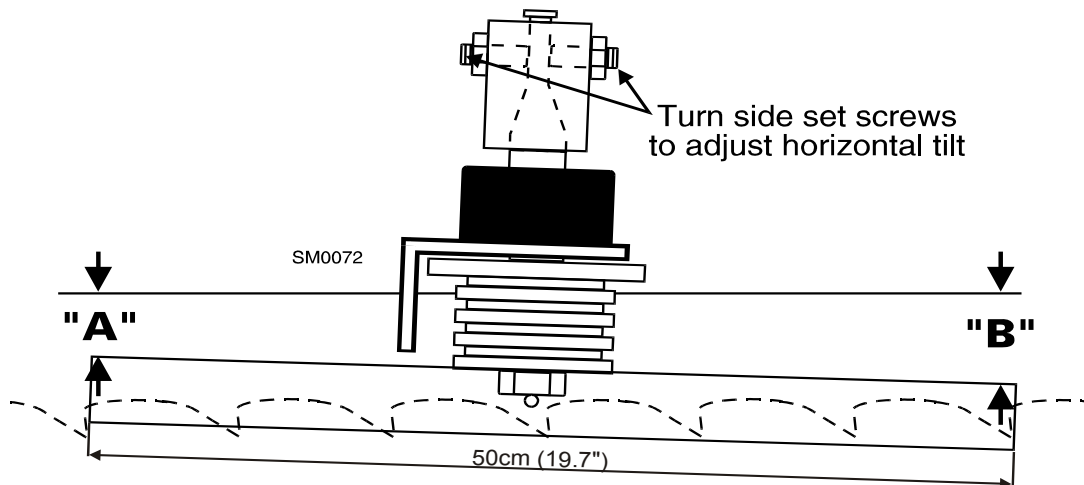

FIG. 6-22

2. Place the Blade Guide Alignment Tool against the face of the outer blade guide roller.
3. Center the tool on the roller and measure between the back edge of the blade and the ruler at the end closest to the inner blade guide ("B").
4. Measure between the back edge of the blade and the other end of the ruler ("A").
5. The roller should be tilted slightly to the left ($A = B - 6.0 \text{ mm [0.24"]}$).
6. Use the side set screws to adjust the horizontal tilt of the roller.
7. Repeat steps 3-7 for the inner blade guide roller.

NOTE: Once the blade guides have been adjusted, any cutting variances are most likely caused by the blade. See the **Blade Handbook, Form #600**.

6.16 Horizontal Adjustment of Side Supports

Logs and boards are clamped against the side supports when sawing. The side supports must be square to the bed to ensure square lumber.

1. Swing the side support down.
2. Measure between the face of the support and the main bed tube. Make measurements at both ends of the side support to make sure that it is parallel to the rail.

See Figure 6-23.

3. Use the two lower bolts to adjust the side support so $B=A$.
4. Repeat for remaining side supports.

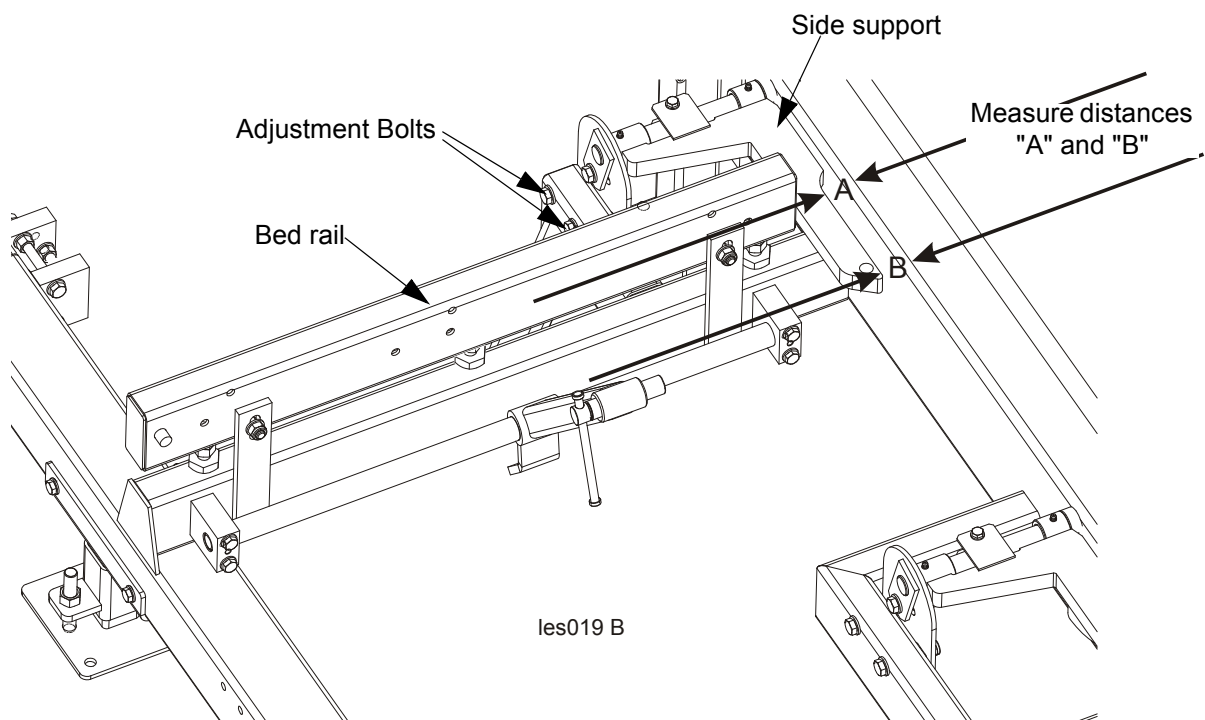

FIG. 6-23

6.17 Vertical Adjustment of Side Supports

1. Place a flat board across the bed rails.
2. Swing a side support up so that it is vertical.
3. Pull back at the top of the support to eliminate slack as if a log were being clamped against it.

See Figure 6-24.

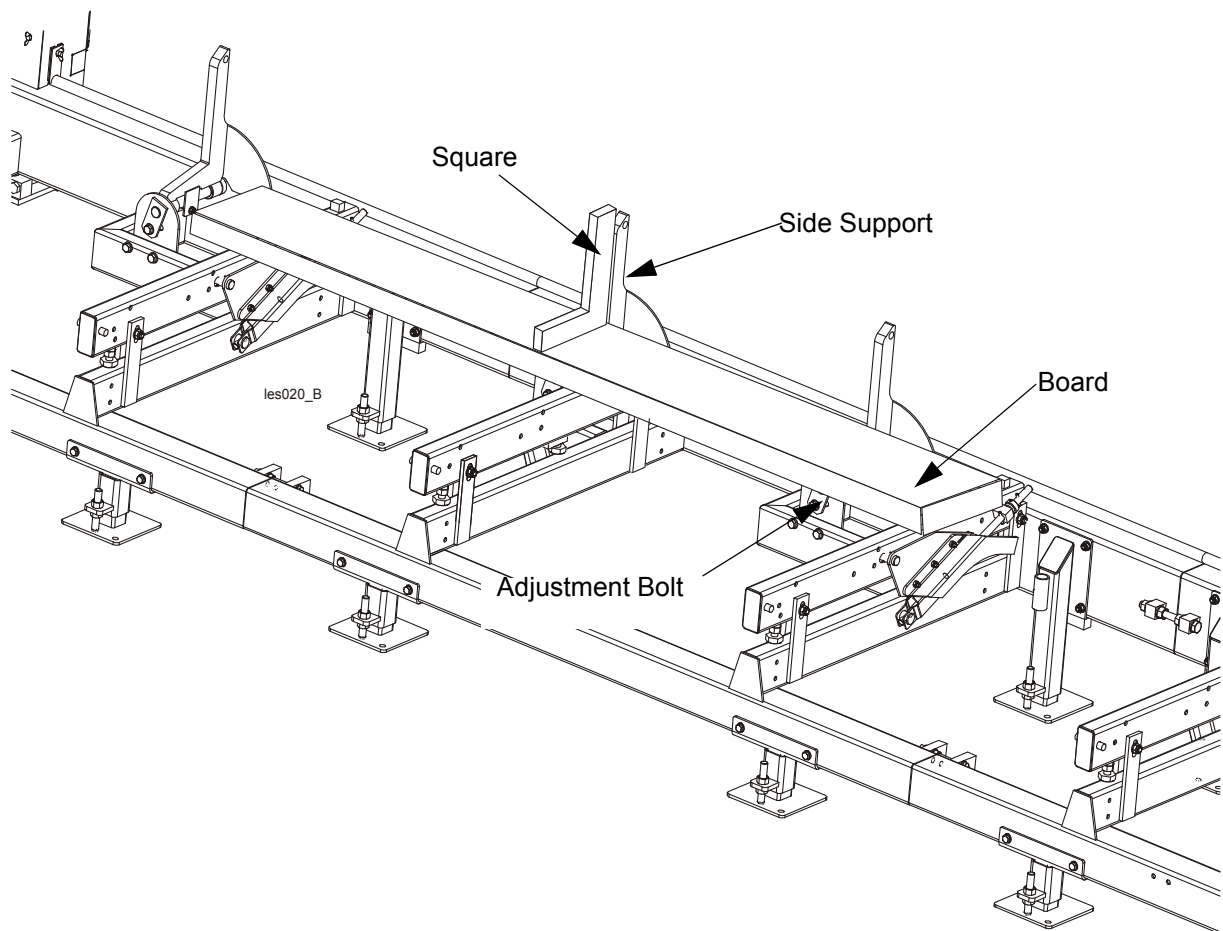

FIG. 6-24

4. Check the angle of each support with a square on the board.
5. The side support should be 90° to the bed rails or leaning forward 1.0 mm (0.04"). Loosen the top adjustment bolt, adjust the side support, and retighten the bolt.
6. Repeat for the remaining side supports.

6.18 Saw Head Tilt

As the blade enters a wide log or cant, the outside of the saw head will drop down slightly. To compensate for the drop, use the lower track roller horizontal nuts to raise the outside of the saw head 1.5 mm (0.06").

1. Move the cutting head so the blade is positioned 375 mm (14.76") above a bed rail.
2. Adjust the lower track roller horizontal nuts until the blade measures 376 mm (14.80") from the bed rail near the outer blade guide.

See Figure 6-25.

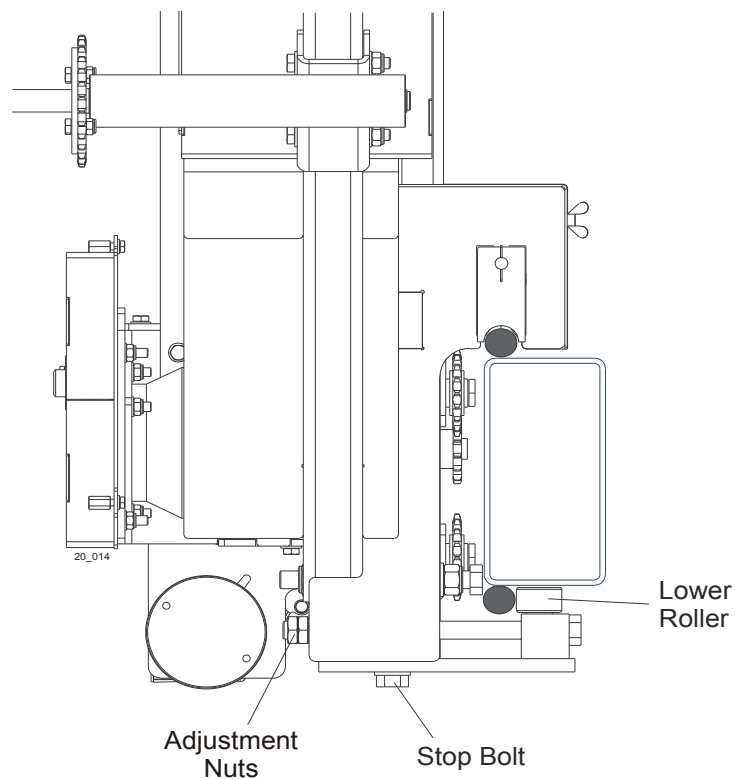

FIG. 6-25

See Figure 6-26.

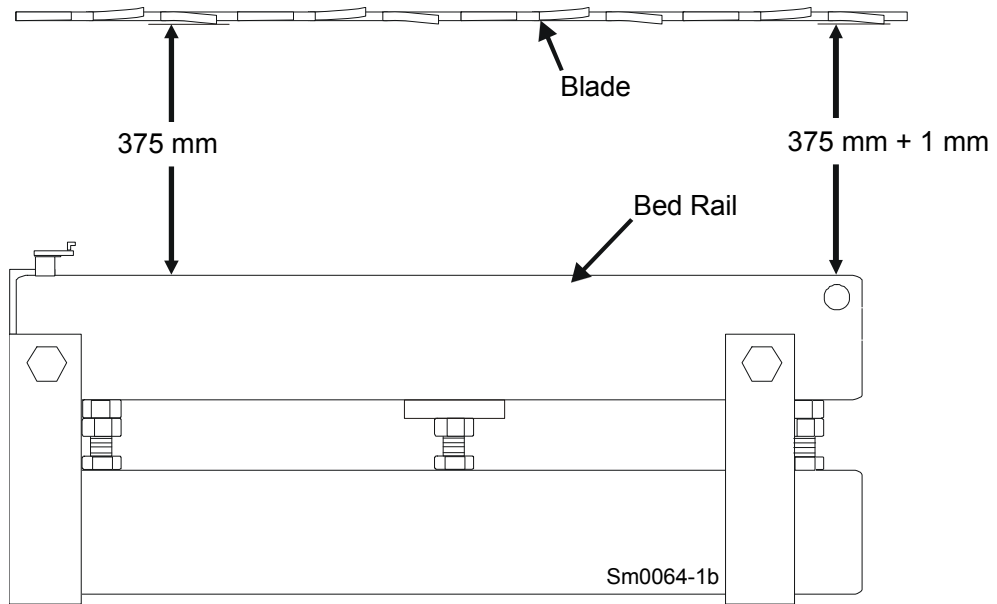

FIG. 6-26

6.19 Blade Height Scale Adjustment

After the entire sawmill has been aligned and all adjustments made, check that the blade height scale indicates the true distance from the blade to the bed rails.

1. Move the saw head so the blade is positioned directly above one of the bed rails. Measure from the bottom edge on a down-set tooth of the blade to the top of the bed rail (or stainless steel sleeve if applicable).

See Figure 6-27.

2. View the blade height scale with eyes level with the indicator.

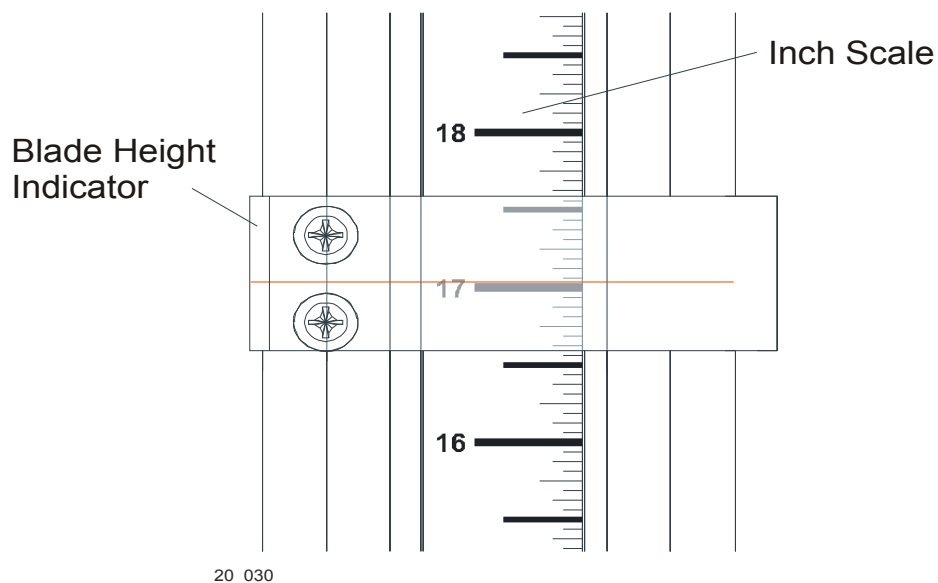

FIG. 6-27

3. Loosen the indicator bracket mounting bolts and adjust the bracket until the indicator is aligned with the correct mark on the scale. Retighten the bracket mounting bolts.

For example, if the measurement from blade to bed rail was 375 mm (14.76"), make sure the indicator reads 375 mm (14.76") on the scale.

EC declaration of conformity according to EC Machinery Directive 2006/42/EC

We herewith declare,

Wood-Mizer Industries Sp. z o.o.
114 Nagorna street, 62-600 Kolo; Poland.

That the following described machine in our delivered version complies with the appropriate basic safety and health requirements of the EC Machinery Directive 2006/42/EC based on its design and type, as brought into circulation by us. In case of alteration of the machine, not agreed by us, this declaration is no longer valid.

Designation of the machine:	SAWMILL
TYPE:	LT20
Model:
No. of manufacturer:
Applicable EC Directives:	EC Machinery Directive 2006/42/EC EC Electromagnetic Compatibility Directive 2004/108/EC
Applicable Harmonized Standards:	PN-EN 1807-2:2013 PN-EN 60204-1:2010 PN-EN 13849-1:2008
Notified Body according to annex IV:	PZ.LSV; Pruf- und Zertifizierungsstelle des Spitzenverbandes der landwirtschaftlichen Sozialversicherung
Notification No	2157
Responsible for:	EC type examination
EC type-examination certificate no.	LSV-EG-2010/123
Year of CE marked affixed	2010
Responsible for Technical Documentation:	Adam Kubiak / R&D Manager Wood-Mizer Industries Sp. z o.o. 62-600 Koło, ul. Nagórna 114 Tel. +48 63 26 26 000
Date/Authorized Signature:	26.01.2010 Adam Kubiak
Title:	R&D Manager