

# **Wood-Mizer®**

## **Parts Manual**

---

**LT20 Series AH**  
**LT20 Series DH**

**rev. D6.00**  
**rev. D5.00**

---



**Safety is our #1 concern!** Read and understand all safety information and instructions before operating, setting up or maintaining this machine.

*April 2003*

*Form #620*

# Table of Contents

# Section-Page

<b>SECTION 1</b>	<b>GENERAL INFORMATION</b>	<b>1-1</b>
1.1	How To Use The Parts List .....	1-1
1.2	Sample Assembly .....	1-1
<b>SECTION 2</b>	<b>BLADE GUIDE ROLLERS &amp; ARM</b>	<b>2-1</b>
2.1	Blade Guide Assembly, Idle Side.....	2-1
2.2	Blade Guide Assembly, Drive Side.....	2-2
2.3	Blade Guide Arm & Rollers .....	2-3
2.4	Blade Guide Arm Drive Assembly.....	2-4
<b>SECTION 3</b>	<b>BLADE WHEELS &amp; TENSIONER</b>	<b>3-1</b>
3.1	Blade Wheel Assembly, Drive Side .....	3-1
3.2	Blade Wheel Assembly, Idle Side .....	3-2
3.3	Blade Tensioner Assembly.....	3-3
<b>SECTION 4</b>	<b>SAW HEAD</b>	<b>4-1</b>
4.1	Middle Throat Screw .....	4-1
4.2	Drive Belt Tensioner, DC Sawmills .....	4-1
4.3	Water Lube Assembly .....	4-3
4.4	LT20AC Saw Head Decals .....	4-4
4.5	LT20DC Saw Head Decals .....	4-6
4.6	Blade Housing Cover .....	4-8
4.7	Control Box (AC Sawmills).....	4-10
4.8	Control Box (DC Sawmills).....	4-12
4.9	Drum Switches .....	4-14
4.10	Sawdust Chute .....	4-15
4.11	Up/Down Cable Chain Assembly .....	4-16
4.12	LT20 Saw Head Rest Pin Assembly .....	4-17
<b>SECTION 5</b>	<b>UP/DOWN ASSEMBLY</b>	<b>5-1</b>
5.1	Up/Down Assembly, AC Mills .....	5-1
5.2	Up/Down Assembly, DC Mills .....	5-3
5.3	Up/Down Chain Tensioner Assembly.....	5-5
5.4	Battery Box Assembly, DC Mills.....	5-6
<b>SECTION 6</b>	<b>UP/DOWN ROLLERS &amp; BLADE HEIGHT SCALE</b>	<b>6-1</b>
6.1	Up/Down Rollers.....	6-1
6.2	Blade Height Scale .....	6-3
6.3	Limit Switches.....	6-5

## Table of Contents

## Section-Page

<b>SECTION 7</b>	<b>POWER FEED &amp; TRACK ROLLERS</b>	<b>7-1</b>
7.1	Power Feed Assembly, AC Mills .....	7-1
7.2	Power Feed Assembly, DC Mills .....	7-3
7.3	Upper Track Rollers And Wipers .....	7-5
7.4	Lower Track Rollers .....	7-7
<b>SECTION 8</b>	<b>BED FRAME ASSEMBLY</b>	<b>8-1</b>
8.1	Bed Rail Assembly, Front (S/M type frame).....	8-1
8.2	Bed Rail Assembly, Rear (S/M type frame).....	8-2
8.3	Bed Rail Assembly, Front Middle (S/M type frame).....	8-3
8.4	Bed Rail Assembly, Rear Middle (S/M type frame).....	8-4
8.5	Bed Rail Assembly (L type frame).....	8-5
8.6	Bed Rail Assembly (L type frame).....	8-6
8.7	Stationary Leg .....	8-7
8.8	Pivot Bed Rail Assembly.....	8-9
8.9	Board Return Table, Log Side Support Assembly .....	8-11
8.10	Tie Down Chain Assembly .....	8-13
8.11	Inspection Platform (DC mills only) .....	8-14
8.12	Bed Frame Decals.....	8-15
<b>SECTION 9</b>	<b>HYDRAULIC SYSTEM</b>	<b>9-1</b>
9.1	Hydraulic Hoses, LT20 Series A/DH .....	9-1
9.2	Hydraulic Hoses, LT20 Series DH.....	9-3
9.3	Hydraulic Control Box, LT20 Series AH3 .....	9-4
9.4	Hydraulic Control Box, LT20 Series AH5/7.....	9-7
9.5	Hydraulic Control Box, LT20 Series DH3.....	9-10
9.6	Hydraulic Control Box, LT20 Series DH5/7.....	9-13
9.7	Hydraulic Power Supply Strip (DC).....	9-16
9.8	Hydraulic System Switch (AC).....	9-18
9.9	Hydraulic Log Loader .....	9-19
9.10	Hydraulic Log Turner .....	9-21
9.11	Hydraulic Log Side Supports .....	9-23
9.12	Hydraulic Log Clamp, Main.....	9-25
9.13	Hydraulic Pull Down Clamp .....	9-27
9.14	Hydraulic Toe Board .....	9-29

## SECTION 1 GENERAL INFORMATION

### 1.1 How To Use The Parts List

- Use the index above to locate the assembly that contains the part you need.
- Go to the appropriate section and locate the part in the illustration.
- Use the number pointing to the part to locate the correct part number and description in the table.
- Parts shown indented under another part are included with that part.
- Parts marked with a diamond (◆) are only available in the assembly listed above the part.

See the sample table below. Sample Part #A01111 includes part F02222-2 and subassembly A03333. Subassembly A03333 includes part S04444-4 and subassembly K05555. The diamond (◆) indicates that S04444-4 is not available except in subassembly A03333. Subassembly K05555 includes parts M06666 and F07777-77. The diamond (◆) indicates M06666 is not available except in subassembly K05555.

<b>1.2 Sample Assembly</b>				
REF	DESCRIPTION (◆ Indicates Parts Available In Assemblies Only)	PART #	QTY.	
	Sample Assembly, Complete (Includes All Indented Parts Below)	A01111	1	
1	Sample Part	F02222-22	1	
	Sample Subassembly (Includes All Indented Parts Below)	A03333	1	
2	Sample Part (◆ Indicates Part Is Only Available With A03333)	S04444-4	1	◆
	Sample Subassembly (Includes All Indented Parts Below)	K05555	1	
3	Sample Part (◆ Indicates Part Is Only Available With K05555)	M06666	2	◆
4	Sample Part	F07777-77	1	

#### **To Order Parts:**

- From Europe call our European Headquarters and Manufacturing Facility in Kolo, Poland at **+48-63-2626000**. From the continental U.S., call our toll-free Parts hotline at **1-800-448-7881**. Have your customer number, vehicle identification number, and part numbers ready when you call.
- From other international locations, contact the Wood-Mizer distributor in your area for parts.

## SECTION 2 BLADE GUIDE ROLLERS & ARM

### 2.1 Blade Guide Assembly, Idle Side

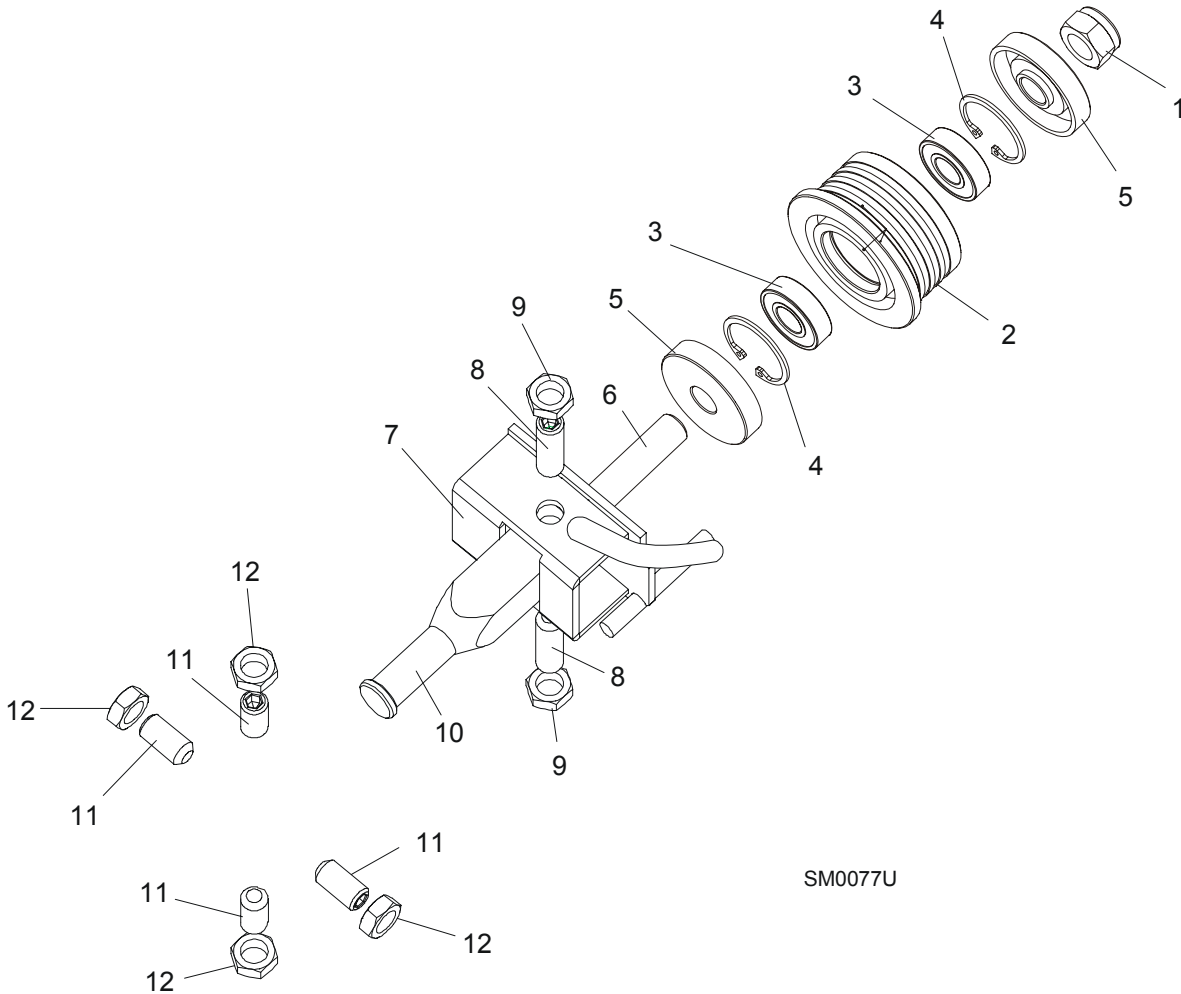

SM0077U

REF	DESCRIPTION (◆ Indicates Parts Available In Assemblies Only)	PART #	QTY.	
	<b>BLADE GUIDE ASSEMBLY, IDLE SIDE</b>	094683	1	
	Roller, Blade Guide Complete Standard	087887	1	
1	Nut, M12-8 Hex Nylon Zinc Lock	F81034-2	1	
2	Roller, Blade Guide Narrow	087889	1	◆
3	Bearing, 6001 2RSR FAG	087893	2	
4	Ring, W28 Inside Retaining	F81090-9	1	
5	Washer, Zinc-plated Spacer	087891-1	2	
6	Shaft, Blade Guide Roller Zinc-plated	087763-1	1	
7	Bracket Weldment, Idle Side Blade Guide Painted	094681-1	1	
8	Screw, M10x1x40 DIN 913 A2-70 Set Stainless Steel	F81015-2	2	
9	Nut, M10x1-04-ST-A2 ISO 8675 Thin	F81033-10	2	
10	Shaft, Blade Guide Mount Zinc-plated	088255-1	1	
11	<b>SCREW, M10X1X20 DIN 913 SET STAINLESS STEEL</b>	F81015-1	4	
12	<b>NUT, M10x1-04-ST-A2 ISO 8675 THIN</b>	F81033-10	4	

**2.2 Blade Guide Assembly, Drive Side**

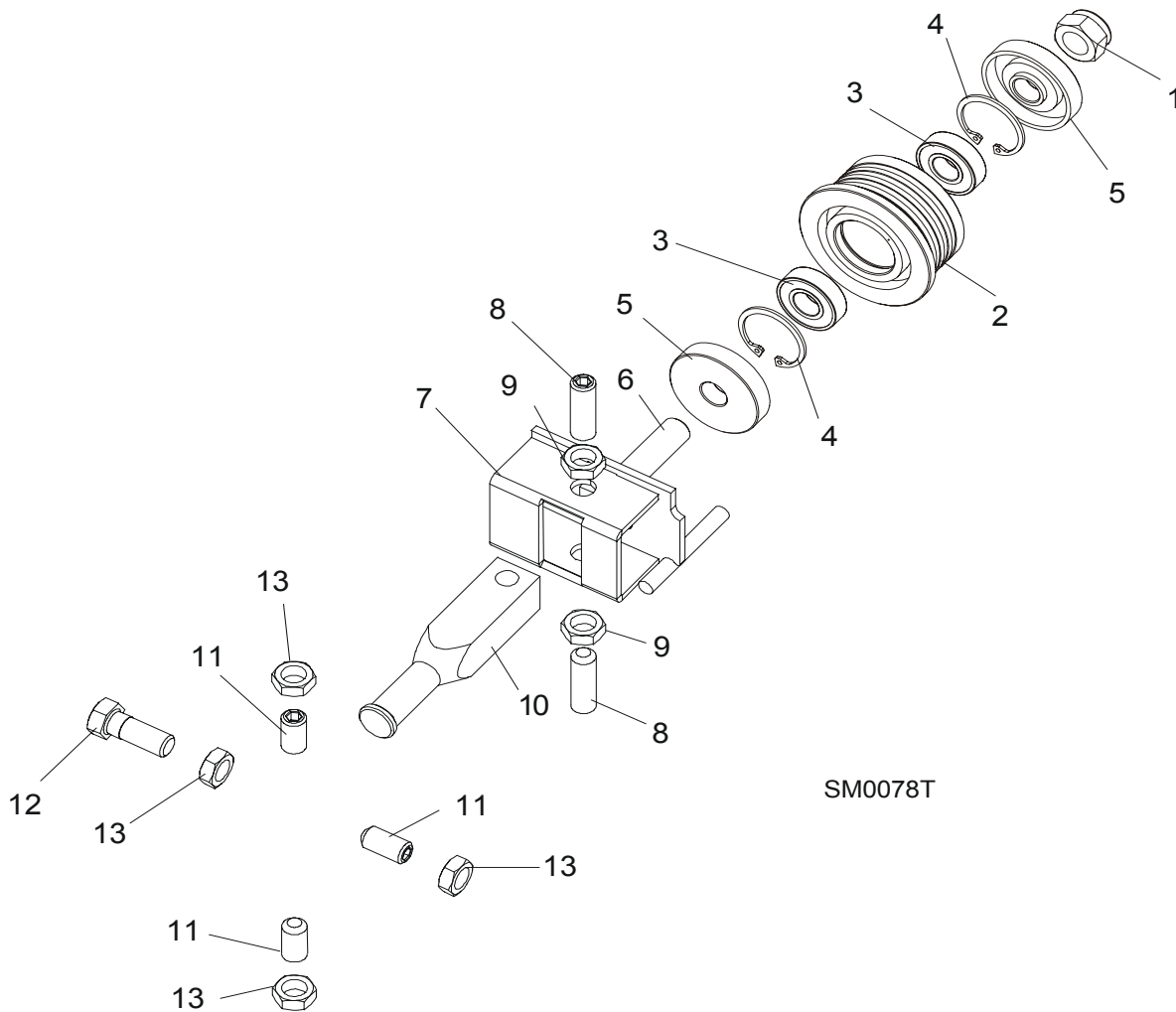

SM0078T

REF	DESCRIPTION (◆ Indicates Parts Available In Assemblies Only)	PART #	QTY.	
	<b>BLADE GUIDE ASSEMBLY, DRIVE SIDE</b>	094682	1	
	Roller, Blade Guide Complete Standard	087887	1	
1	Nut, M12-8 Hex Nylon Zinc Lock	F81034-2	1	
2	Roller, Blade Guide Narrow	087889	1	◆
3	Bearing, 6001 2RSR FAG	087893	2	
4	Ring, W28 Inside Retaining	F81090-9	1	
5	Washer, Zinc-plated Spacer	087891-1	2	
6	Shaft, Blade Guide Roller Zinc-plated	087763-1	1	
7	Bracket Weldment, Blade Guide Painted	094679-1	1	
	Screw Kit, Blade Guide Adjustment w/Nuts (for two blade guide assemblies)	K09942	1	
8	Screw, M10x1x40 DIN 913 A2-70 Set Stainless Steel	F81015-2	2	
9	Nut, M10x1-04-ST-A2 ISO 8675 Thin	F81033-10	2	
10	Shaft, Blade Guide Mount Zinc-plated	088255-1	1	
11	<b>SCREW, M10X1X20 DIN 913 SET STAINLESS STEEL</b>	F81015-1	3	
12	<b>BOLT, M10X1X25 DIN 933 STAINLESS STEEL</b>	F81003-28	1	

13	NUT, M10x1-04-ST-A2 ISO 8675 THIN	F81033-10	4	
----	-----------------------------------	-----------	---	--

## 2.3 Blade Guide Arm & Rollers

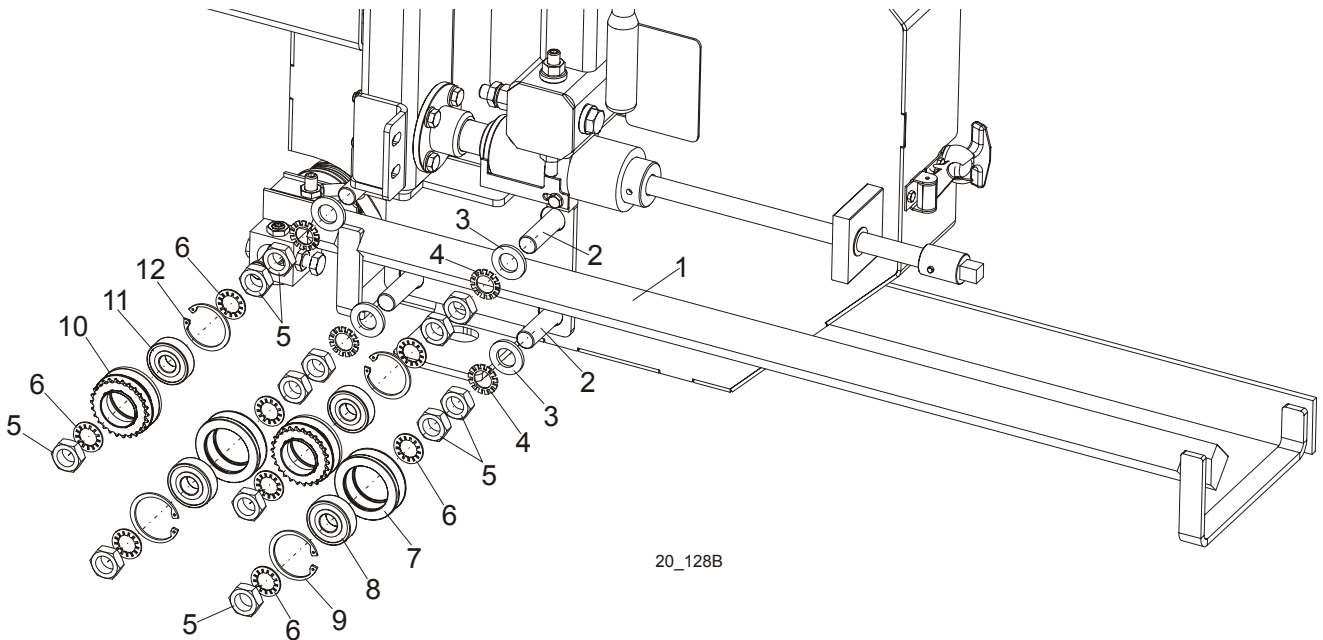

REF	DESCRIPTION (◆ Indicates Parts Available In Assemblies Only)	PART #	QTY.	
1	BLADE GUIDE ARM WELDMENT	096397-1	1	
2	BOLT, BLADE GUIDE ARM ROLLER CAM	086508-1	4	
3	WASHER, M16,FLAT ZINC	F81058-1	4	
4	WASHER, 5/8" EXTERNAL STAR	F05011-26	4	
5	NUT, 5/8-18 HEX JAM	F05010-11	12	
6	WASHER, 5/8" INTERNAL STAR	F05011-25	8	
	<b>ROLLER ASSY, BLADE GUIDE ARM WITH BEARING</b>	093855	2	
7	Roller, Blade Guide Arm V-Groove	093856-1	1	◆
8	Bearing, 6203 2RSP6-5/8 CX	095087	1	
9	Ring, W40 Retaining	F81090-3	1	
	<b>ROLLER ASSY, BLADE GUIDE ARM DRIVE W/SPROCKET COMPLETE</b>	501496	2	
10	Roller, Blade Guide Arm Drive w/Sprocket	501495-1	1	◆
11	Bearing, 6203-2 RSP6-5/8 CX	095087	1	
12	Ring, W40 Spring Retaining	F81090-3	1	

## 2.4 Blade Guide Arm Drive Assembly

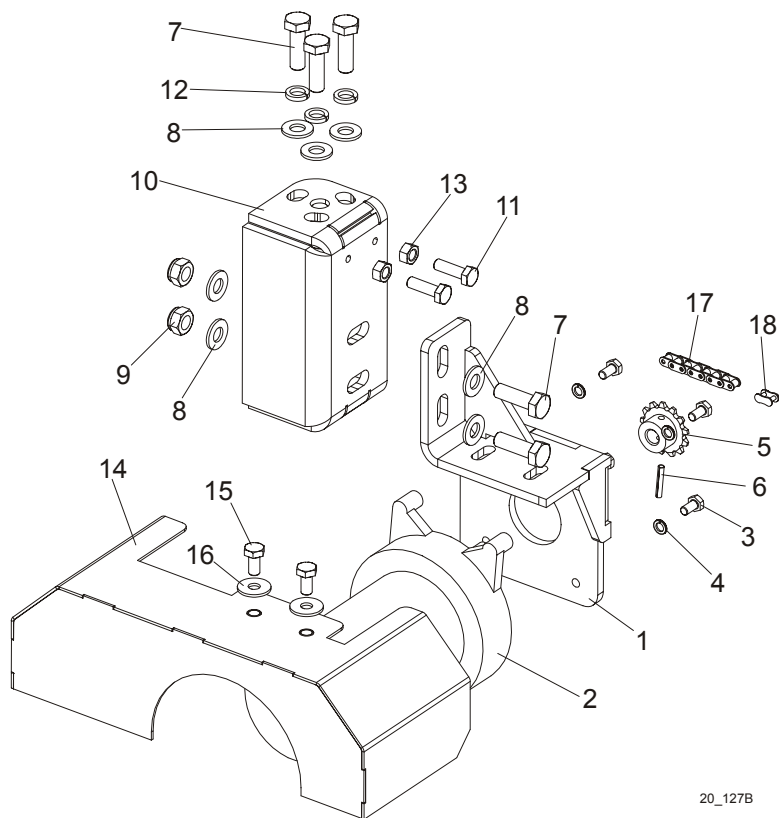

20\_127B

REF	DESCRIPTION (◆ Indicates Parts Available In Assemblies Only)	PART #	QTY.
	<b>DRIVE ASSEMBLY, BLADE GUIDE ARM</b>	096396	1
1	BRACKET, BLADE GUIDE ARM MOTOR MOUNT	096390-1	1
2	MOTOR, BLADE GUIDE ARM 53:1 GEAR	P09698-1	1
3	SCREW, 10-32X1/2 HH MACHINE	F05004-60	4
4	WASHER, 5.1 SPLIT LOCK	F81052-2	4
5	SPROCKET, 25B13X.3130	P09970	1
6	PIN, 1/8X3/4 ROLL	F05012-6	1
7	BOLT, M8x25-8.8-B HEX HEAD FULL THREAD ZINC	F81002-5	5
8	WASHER, 8.4 FLAT ZINC	F81054-1	7
9	NUT, M8-8-B HEX NYLON ZINC LOCK	F81032-2	2
10	BRACKET, BLADE GUIDE ARM DRIVE	501265-1	1
11	BOLT, M6x20-8.8 HEX HEAD FULL THREAD ZINC	F81001-2	2
12	WASHER, 8.2 SPLIT LOCK	F81054-4	3
13	NUT, M6-8.8 HEX GRADE 5 ZINC	F81031-1	2
14	<b>COVER, LT20 BLADE GUIDE ARM MOTOR</b>	097424-1	1
15	<b>BOLT, M6X12MM HEX HEAD ZINC</b>	F81001-7	2
16	<b>WASHER, 6.5 FLAT ZINC</b>	F81053-11	2
17	<b>CHAIN, 20 1/4IN #25</b>	P09984	1
18	<b>LINK, 25 MASTER</b>	P09983	1



## SECTION 3 BLADE WHEELS & TENSIONER

### 3.1 Blade Wheel Assembly, Drive Side

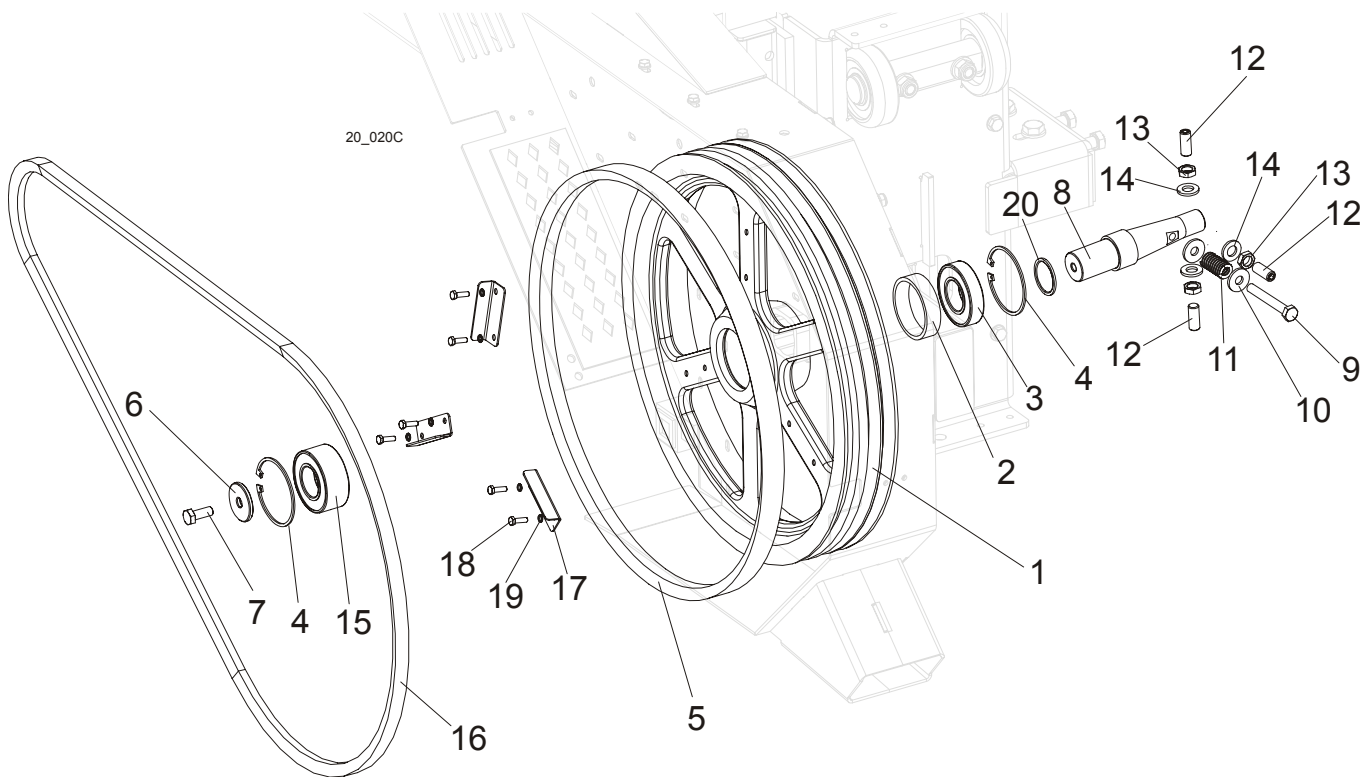

REF	DESCRIPTION (◆ Indicates Parts Available In Assemblies Only)	PART #	QTY.
	<b>BLADE WHEEL ASSEMBLY, LT20 DRIVE SIDE</b>	091612	1
1	Wheel, LT20 Drive Side Blade	090646-1	1
2	Bushing, Bearing Spacer	096778	1
3	Bearing, 6207 2RS 35x72x17 FAG	014811	1
4	Ring, W72 Retaining	F81090-4	2
5	Belt, B57 Blade Wheel	P04185	1
6	Washer, Drive Side Blade Wheel	092006	1
7	Bolt, M10x25-8.8 Hex Head Full Thread Zinc	F81003-11	1
8	Shaft, LT15/20 Drive Side Blade Wheel	093850	1
9	Bolt, M10X65-8.8-B Hex Head Zinc	F81003-67	1
10	Washer, Zinc	098813-1	2
11	Spring, 19x38 Compression	034430	1
12	Screw, M12x1,25x30 DIN913 Set	F81016-1	4
13	Washer, 13 Flat Zinc	F81056-1	4
14	Nut, M12x1,25 DIN439 Thin Stainless Steel	F81034-9	4
15	Bearing, 3207B, 2RSR. TVH FAQ	092005	1
16	Drive Belt, 2BX81, AC Sawmills (E11, E15) Drive Belt, 2BX84, DC Sawmills (D17, D22 & G25)	014819-2 (AC) 088110 (DC)	1 2
17	Wing	097808-1	3
18	Bolt, M6x20mm, HH, Full Thread, Zinc	F81001-2	6
19	Washer, M6 Split Lock Zinc	F81053-3	6
20	Washer, φ35 Special	091851	1

## 3.2 Blade Wheel Assembly, Idle Side

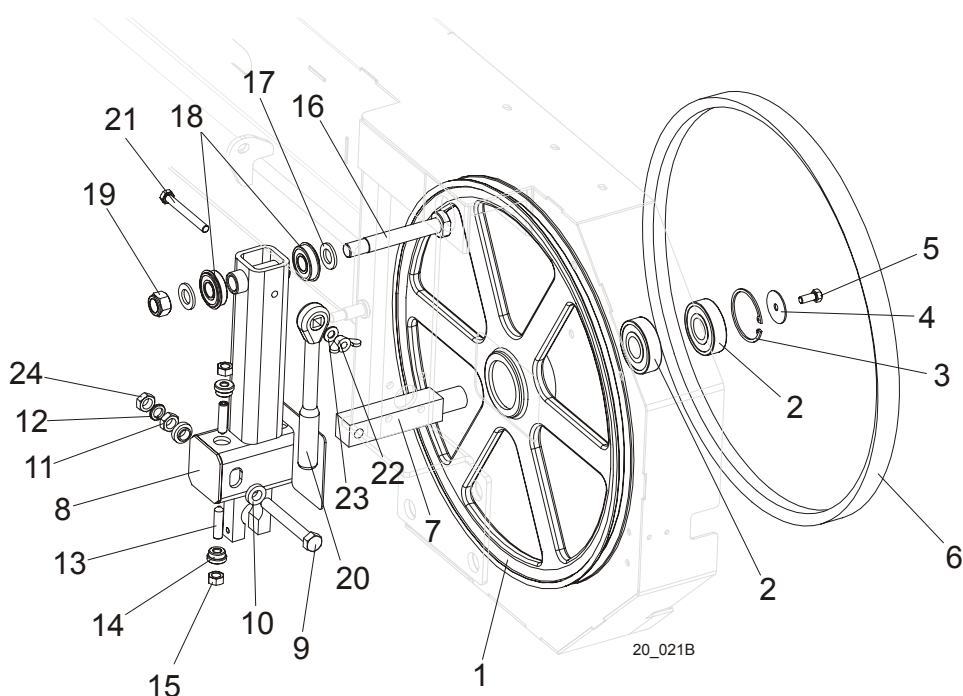

REF	DESCRIPTION (◆ Indicates Parts Available In Assemblies Only)	PART #	QTY.
	<b>WHEEL ASSEMBLY, IDLE SIDE BLADE</b>	A08218	1
1	Sheave, 18.62" Idler	P08125	1
2	Bearing, 6305 2RS NSK	P08066	2
3	Ring, 2 7/16" Inside Retaining	F04254-21	1
4	<b>WASHER, WHEEL RETAINING ZINC-PLATED</b>	093854-1	1
5	<b>BOLT, M8 x 25mm HEX HEAD GR 5.8 ZINC</b>	F81002-5	1
6	<b>BELT, B57 BLADE WHEEL</b>	P04185	1
7	<b>SHAFT, IDLE SIDE WHEEL METRIC</b>	096045	1
8	<b>HOUSING, IDLER SHAFT</b>	091595	1
9	<b>BOLT, M12X1.25X100-8.8 HEX HEAD FULL THREAD ZINC</b>	F81004-41	1
10	<b>SPACER, FLANGED ZINC-PLATED</b>	086769-1	2
11	<b>NUT, M12 X 1.25-8 HEX ZINC</b>	F81034-8	1
12	<b>WASHER, 12.2 SPLIT ZINC LOCK</b>	F81056-2	1
13	<b>SCREW, M10 X 40-45H HEX SOCKET SET CONE POINT ZINC</b>	F81003-61	2
14	<b>BUSHING, M10 IDLER SHAFT HOUSING</b>	086987	2
15	<b>NUT, M10-8-B HEX ZINC</b>	F81033-3	2
16	<b>PIN, IDLER ARM BEARINGS</b>	086404	1
17	<b>WASHER, 17 FLAT ZINC</b>	F81058-1	2
18	<b>BEARING, 6203-2RS NR NSK W/RING</b>	086395	2
19	<b>NUT, M16-8 HEX NYLON ZINC LOCK</b>	F81036-2	1
20	<b>WRENCH, LT20 BLADE TENSION</b>	091620	1
21	<b>BOLT, M10x90-8.8-B HEX HEAD ZINC</b>	F81003-66	1
22	<b>STUD, M10x25-8.8 ZINC-PLATED</b>	F81003-8	1
23	<b>WASHER, M10 FLAT ZINC</b>	F81055-1	1
24	<b>NUT, M12x1.25 DIN439 THIN STAINLES STEEL</b>	F81034-9	1

### 3.3 Blade Tensioner Assembly

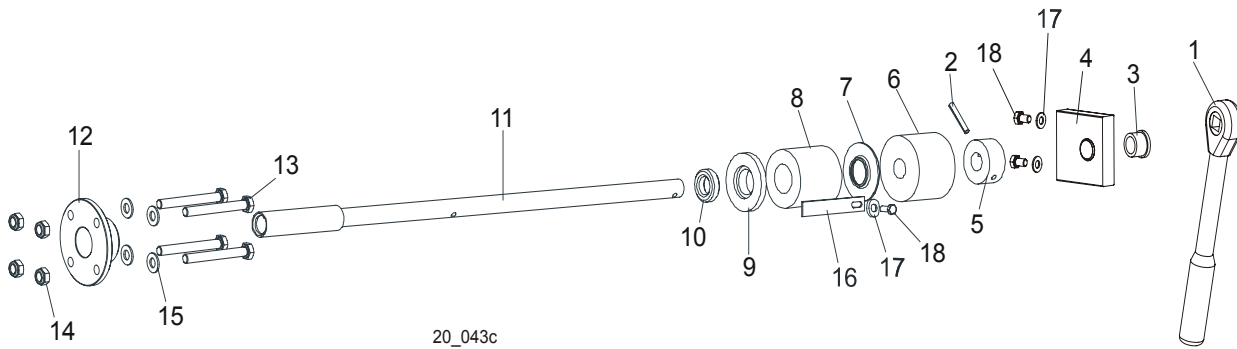

REF	DESCRIPTION (◆ Indicates Parts Available In Assemblies Only)	PART#	QTY.
	<b>BLADE TENSIONER ASSEMBLY</b>	090587	1
1	Wrench, LT20 Blade Tension	091620	1
2	Pin, 5 x 30 Zinc Roll	F81044-21	1
	Bracket, Tension Handle Mount w/Bushing	096729	1
3	Bushing GFM-1618-17(IGUS)	089589	1
4	Bracket, Painted	096730	1
5	Collar, Blade Tensioner	086712-1	1
6	Bushing, Rubber Stop	P12165	1
7	Guide, LT15 Tension Handle	014925	1
8	Spring, LT15 Rubber Blade Tensioner	014828	1
9	Washer, Rubber Spring Front	086674-1	1
10	Bearing, 51103 FLT Ball Thrust	086675	1
11	Shaft Weldment, Blade Tensioner Zinc-plated	101338-1	1
12	Nut, Blade Tensioner	086672-1	1
13	Bolt, M8x70 8.8 Hex Head Zinc	F81002-71	4
14	Nut, M8-8-B Hex Nylon Zinc Lock	F81032-2	4
15	Washer, 8.4 Zinc Flat	F81054-1	8
16	Indicator, LT15 Blade Tension Zinc-plated	092467-1	1
17	Washer, 6.4 Zinc Flat	F81053-1	1
18	Bolt, M6x16 8.8 Hex Head Full Thread Zinc	F81001-15	1

## SECTION 4 SAW HEAD

### 4.1 Middle Throat Screw

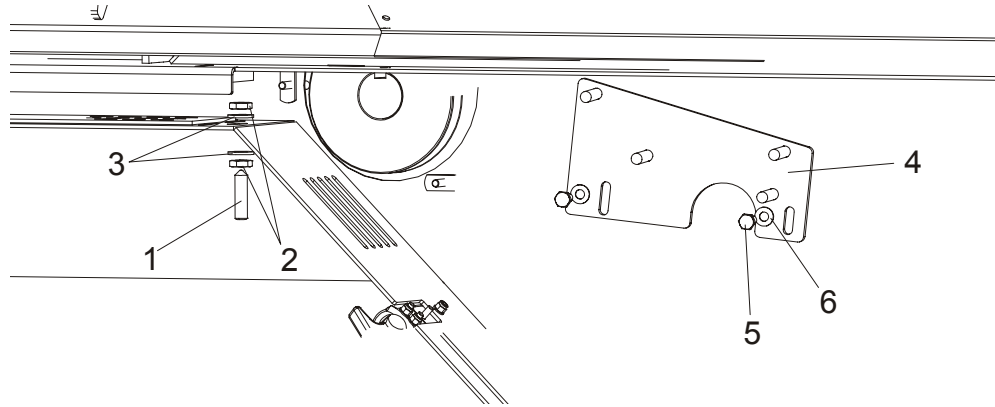

REF	DESCRIPTION (◆ Indicates Parts Available In Assemblies Only)	PART #	QTY.
1	SCREW, M10 X 40-45H HEX SOCKET SET CONE POINT ZINC	F81003-61	1
2	NUT, M10-8-B ZINC HEX	F81033-6	2
3	WASHER, 10.5 ZINC FLAT	F81055-1	2
4	BRACKET, DRIVE BELT SUPPORT, UPPER	092668-1	1
5	BOLT, M8X20-5.8 HEX HEAD FULL THREAD ZINC	F81002-1	2
6	WASHER, 8.4 ZINC FLAT	F81054-1	2

### 4.2 Drive Belt Tensioner, DC Sawmills

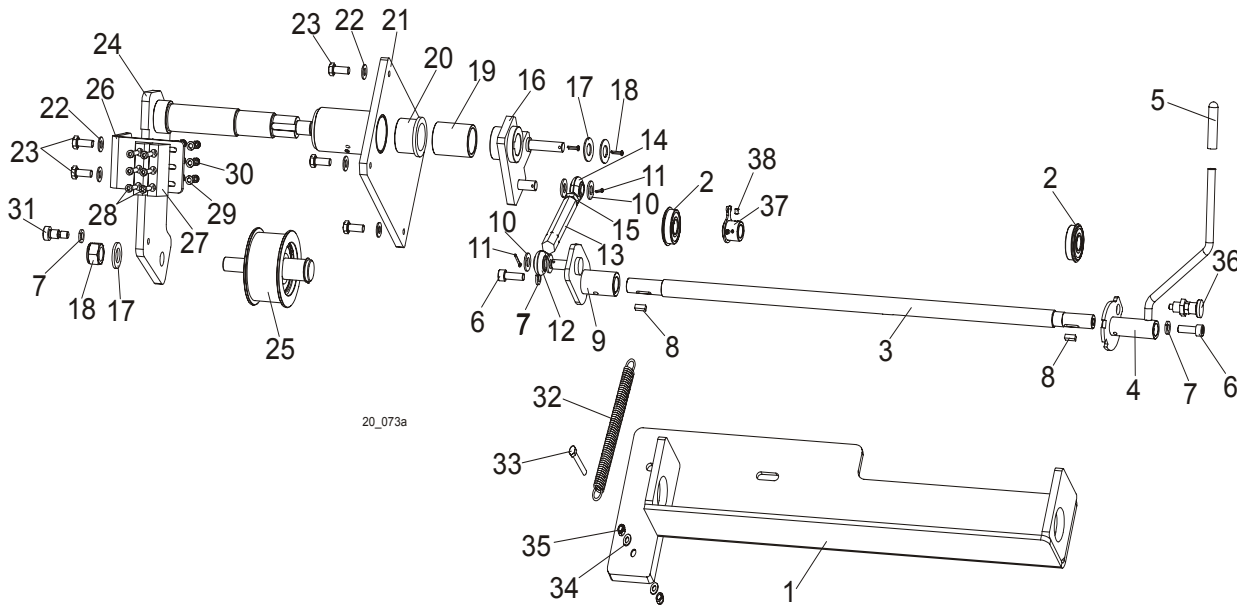

REF	DESCRIPTION (◆ Indicates Parts Available In Assemblies Only)	PART #	QTY.
	BELT TENSIONER, LT20 COMPLETE, D22	098456	1
	BELT TENSIONER, LT20 COMPLETE, G25	097842	1

1	Mount Weldment, Belt Tensioner Ptd	091169-1	1	
2	Bearing, 6203-2RS NR NSK w/Ring	086395	2	
3	Rod, LT20 Belt Tensioner Ptd	091176-1	1	
4	Handle Weldment, Accelerate/Brake, Ptd	097837-1	1	
5	Grip, Handle 1/2" ID x 3" Long	014835	1	
6	Screw, M8x25 -8.8 Hex Socket Head Cap Zinc	F81002-21	2	
7	Washer, 8.2 Split Lock Zinc	F81054-4	3	
8	Key, B 5x5.1x14 Parallel	087365	2	
9	Bracket, Belt Tensioner Pivot	091245-1	1	
10	Washer, 10.5 Zinc Flat	F81055-1	4	
11	Pin, 2.5x20 Zinc Cotter	F81043-1	2	
12	Rod End, 7/16-20 Right-Hand Male	P11579	1	
13	Turnbuckle, Clutch/Brake	S11577	1	
14	Rod End, 7/16-20 Left-Hand Male	P11578	1	
15	Nut, 7/16-20 Zinc	F05010-38	1	
16	Arm Weldment, Belt Tensioner Ptd	091172-1	1	
17	Washer, 17 Zinc Flat	F81058-1	2	
18	Nut, M16-8 Hex Nylon Zinc Lock	F81036-2	2	
19	Bushing, Spacer Ptd	091351-1	1	
20	Bushing, MFM-3240-30 (IGUS)	088461	2	
21	Mount Weldment, Tensioner Shaft Ptd	091112-1	1	
22	Washer, 8.4 Zinc Flat	F81054-1	7	
23	Bolt, M8x20-5.8 Hex Head Full Thread Zinc	F81002-1	6	
24	Shaft Weldment, Belt Tensioner Ptd	097828-1	1	
25	Roller, Belt Tension	097832	1	
26	Bracket, Brake Block Mount Ptd	091248-1	1	
27	Block, F9150 123 Belt Tensioner Brake	087648	2	
28	Screw, M5x25-8.8 Hex Socket Head Cap Zinc	F81000-7	6	
29	Washer, 5.3 Zinc Flat	F81052-1	6	
30	Nut, M5-8 Zinc DIN 985	F81030-2	6	
31	Screw, M8x25-8.8 Hex Socket Head Cap Zinc	F81002-21	2	
32	Spring, Hydraulic Log Turner	P09136	1	
33	Bolt, M8x45-8.8 Hex Head Zinc	F81002-17	1	
34	Washer, 8.4 Zinc Flat	F81054-1	2	
35	Nut, M8-8-B Hex Nylon Zinc Lock	F81032-2	2	
36	Pin, Detent	089939	1	
37	Tension Member, (G25 Engine Only) Ptd	092535-1	1	
38	Set Screw M6x8	F81013-1	2	

#### 4.3 Water Lube Assembly

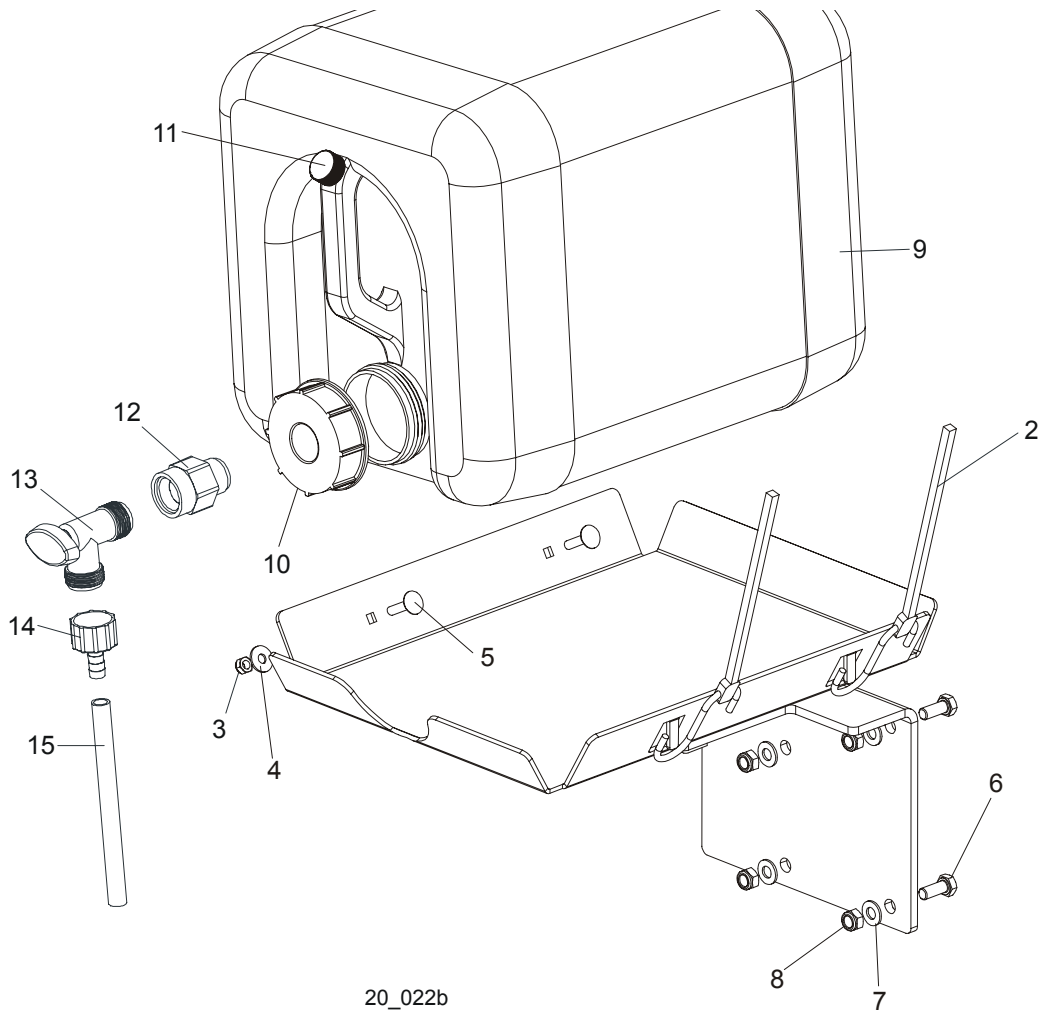

REF	DESCRIPTION (◆ Indicates Parts Available In Assemblies Only)	PART #	QTY.
	<b>BOTTLE KIT, LT20 WATER LUBE</b>	091036	1
1	Tray Weldment, LT20 Water Lube	091033-1	1
2	Strap, 20" Rubber	P11668	2
3	Nut, M6-8-B Hex Nylon Zinc Lock	F81031-2	2
4	Washer, 6.5 Zinc Flat	F81053-11	2
5	Bolt, M6x25-8.8 Carriage Head Zinc	F81001-20	2
6	Bolt, M8x20-8.8 Hex Head Full Thread Zinc	F81002-1	2
7	Washer, 8.4 Zinc Flat	F81054-1	2
8	Nut, M8-8-B Hex Nylon Zinc Lock	F81032-2	2
	Bottle, 5-gallon Water Complete	014637-1	1
9	Bottle, 5-gallon Water	101295	1
10	Cap, 5-gallon Water Bottle	036745	1
11	Cap, Vent Valve	061742	1
12	Fitting, 3/4FPT x 3/4MPT	014636	1
13	Fitting, Water Lube Shutoff Valve	014100	1
14	Fitting, 5/8" NPT to 3/8" Hose Barb	014113	1
15	Tubing, Water Lube	R01885	2.1 m

### 4.4 LT20AC Saw Head Decals

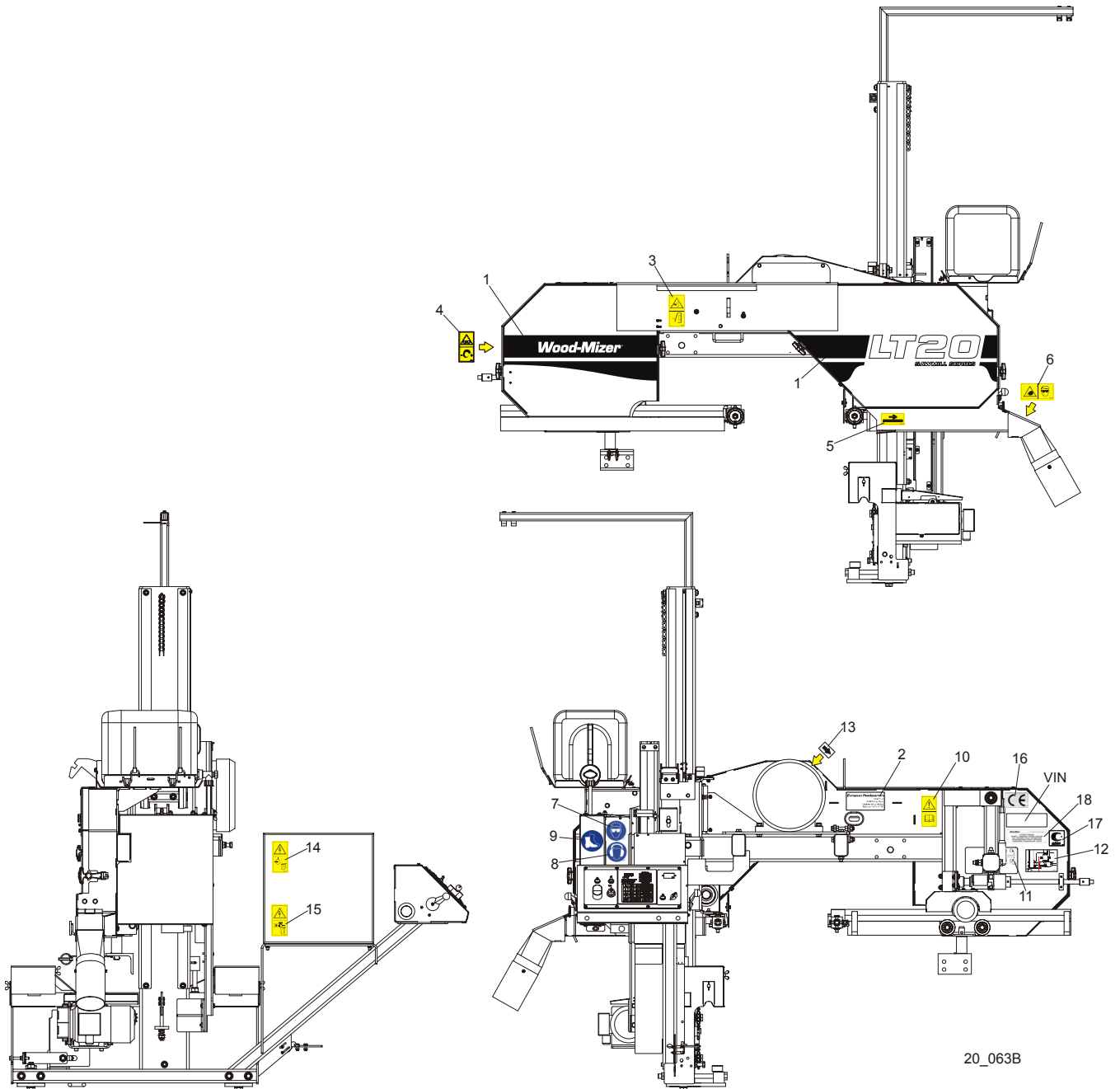

20\_063B

REF	DESCRIPTION (◆ Indicates Parts Available In Assemblies Only)	PART #	QTY.
1	DECAL, LT20 SERIES SAWMILL	092762	1
	PICTOGRAPHIC DECAL KIT, LT20AC	099509	1
2	DECAL, EUROPEAN HEADQUARTERS ADDRESS	015841	1
3	DECAL, SAWMILL COVERS CAUTION	099220	1
4	DECAL, BLADE TENSION (PICTOGRAM)	099219	1
5	DECAL, BLADE MOVEMENT DIRECTION (PICTOGRAM)	096321	1
6	DECAL, SAWDUST CHUTE WARNING (PICTOGRAM)	099222	1
7	DECAL, EYE PROTECTION WARNING (PICTOGRAM)	S12004G	1

8	DECAL, EAR PROTECTION WARNING (PICTOGRAM)	S12005G	1	
9	DECAL, USE SAFETY BOOTS (PICTOGRAM)	501465	1	
10	DECAL, READ OPERATOR'S MANUAL (PICTOGRAM)	096317	1	
11	DECAL, BLADE ALIGNMENT	P11789	1	
12	DECAL, BLADE TENSION INDICATOR ADJUSTMENT	092597	1	
13	DECAL, MOTOR ROTATION DIRECTION	S20097	1	
14	DECAL, HIGH VOLTAGE INSIDE THE ELECTRIC BOX (PICTOGRAM)	096316	2	
15	DECAL, REMOVE THE PLUG BEFORE OPENING THE BOX (PICTOGRAM)	096319	2	
16	DECAL, CE CERTIFIED SAWMILL	P85070	1	
17	DECAL, RUSSIAN SAFETY CERTIFICATION	099401	1	
18	DECAL, INTERNATIONAL SAWMILL NAME	501466	1	
	DECAL, BLADE SETTING	P85066	1	



### 4.5 LT20DC Saw Head Decals

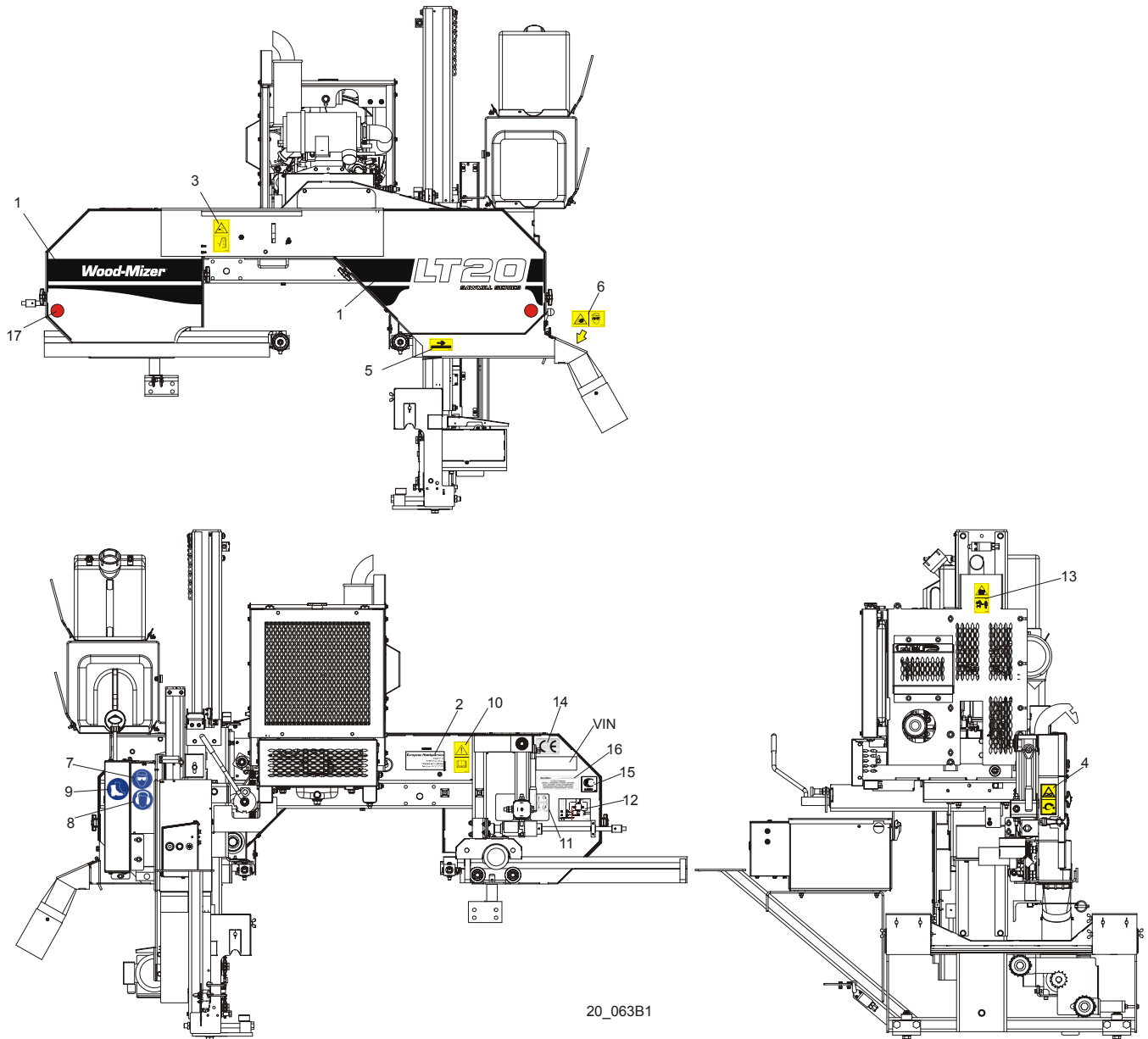

20\_063B1

REF	DESCRIPTION (◆ Indicates Parts Available In Assemblies Only)	PART #	QTY.
1	DECAL, LT20 SERIES SAWMILL	092762	1
	<b>PICTOGRAPHIC DECAL KIT, LT20DC</b>	099510	1
2	DECAL, EUROPEAN HEADQUARTERS ADDRESS	015841	1
3	DECAL, SAWMILL COVERS CAUTION	099220	1
4	DECAL, BLADE TENSION (PICTOGRAM)	099219	1
5	DECAL, BLADE MOVEMENT DIRECTION (PICTOGRAM)	096321	1
6	DECAL, SAWDUST CHUTE WARNING (PICTOGRAM)	099222	1
7	DECAL, EYE PROTECTION WARNING (PICTOGRAM)	S12004G	1
8	DECAL, EAR PROTECTION WARNING (PICTOGRAM)	S12005G	1
9	DECAL, USE SAFETY BOOTS (PICTOGRAM)	501465	1

## 4

**Saw Head***LT20DC Saw Head Decals*

10	DECAL, READ OPERATOR'S MANUAL (PICTOGRAM)	096317	1	
11	DECAL, BLADE ALIGNMENT	P11789	1	
12	DECAL, BLADE TENSION INDICATOR ADJUSTMENT	092597	1	
13	DECAL, KEEP AWAY - HOT PARTS (PICTOGRAM)	086099	1	
14	DECAL, CE CERTIFIED SAWMILL	P85070	1	
15	DECAL, RUSSIAN SAFETY CERTIFICATION	099401	1	
16	DECAL, INTERNATIONAL SAWMILL NAME	501466	1	
	DECAL, BLADE SETTING	P85066	1	
17	<b>REFLECTOR, 2 DIA RED (MOBILE SAWMILLS ONLY)</b>	P07452	1	

## 4.6 Blade Housing Cover

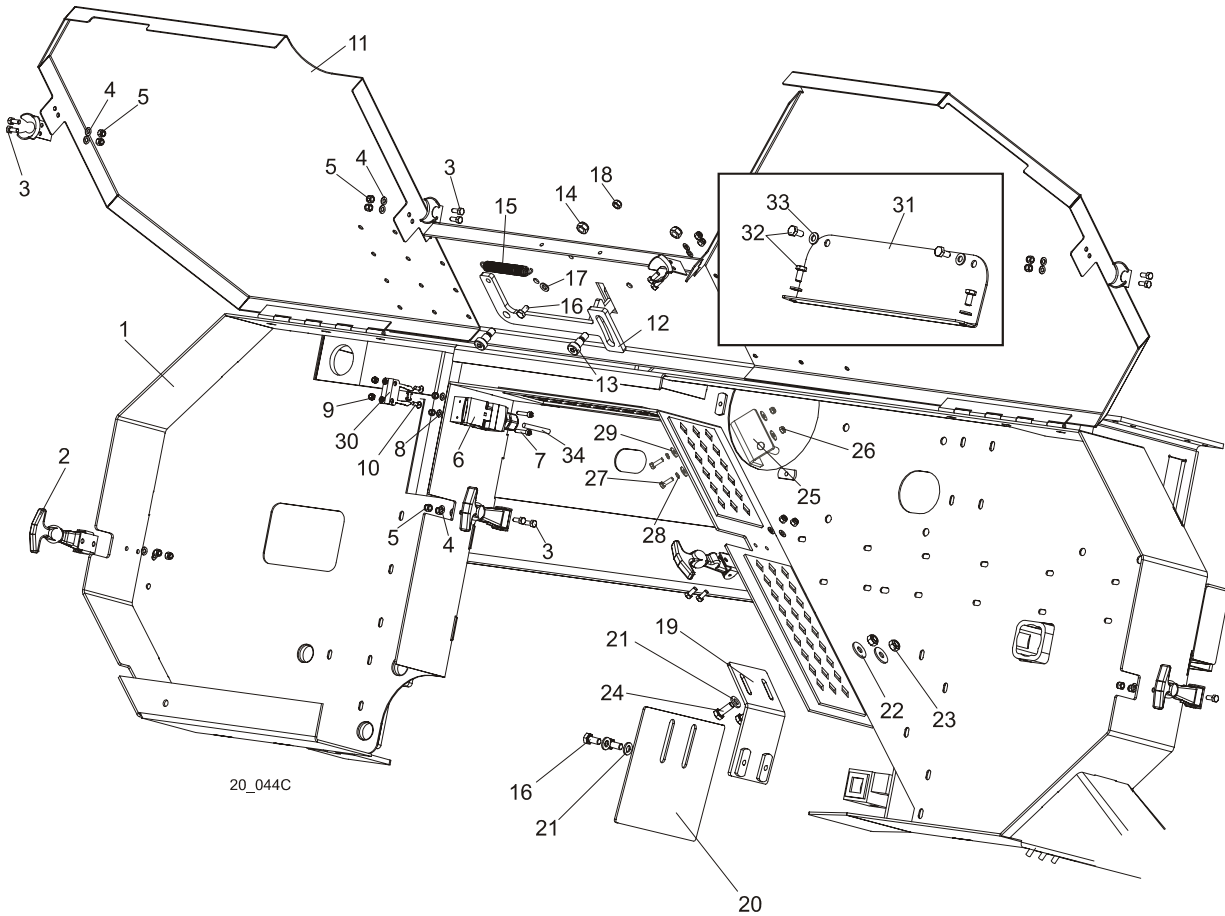

REF	DESCRIPTION (◆ Indicates Parts Available In Assemblies Only)	PART #	QTY.
1	SAW HEAD WELDMENT, LT20	090567	1
2	LATCH, FLEXIBLE DRAW	014829	4
3	BOLT, M5 X 12-5.8 HEX HEAD FULL THREAD ZINC	F81000-5	16
4	WASHER, 5.3 ZINC FLAT	F81052-1	16
5	NUT, M5-8 HEX NYLON ZINC LOCK	F81030-2	16
6	SWITCH, AZ17-11ZRK SAFETY KEY	094232	1
7	SCREW, M4 X 35 8.8 HEX SOCKET HEAD CAP ZINC	F81011-34	2
8	WASHER, 4.3 ZINC FLAT	F81051-2	4
9	NUT, M4-B HEX NYLON ZINC LOCK	F81029-1	4
10	SCREW, M4 X 12 5.8-B SLOTTED COUNTERSUNK HEAD ZINC	F81011-43	2
11	COVER WELDMENT, LT20 BLADE HOUSING PTD	096776-1	1
12	PAWL, LOCKING PTD	090643-1	1
13	SCREW, 10/M8 X 12-12.9 ISO-7379 SOCKET HEAD SHOULDER	F81003-62	2
14	NUT, M8-8-B HEX NYLON ZINC LOCK	F81032-2	2
15	SPRING, 1,6x12x38 EXTENSION	092208	1
16	BOLT, M6 X 12-8.8 HEX HEAD FULL THREAD ZINC	F81001-7	3
17	WASHER, 6.4 ZINC FLAT	F81053-1	1

18	NUT, M6-8-B HEX NYLON ZINC LOCK	F81031-2	1	
19	BRACKET, BLADE GUIDE ROLLER GUARD PAINTED	092378-1	1	
20	GUARD, BLADE GUIDE ROLLER PAINTED	092379-1	1	
21	WASHER, 6.4 ZINC FLAT	F81053-1	4	
22	WASHER, 6.5 ZINC FLAT	F81053-11	2	
23	NUT, M6-8-B HEX NYLON ZINC LOCK	F81031-2	2	
24	BOLT, M6X16 8.8 HEX HEAD FULL THREAD ZINC	F81001-15	2	
25	BRACKET WLDMT, PTD DRIVE BELT SUPPORT	092636-1	1	
26	NUT, M6-8-B HEX NYLON ZINC LOCK	F81031-2	2	
27	BOLT, M6 X 20-8.8 HEX HEAD FULL THREAD ZINC	F81001-2	2	
28	WASHER 6,1 FE/ZN9 PN/M-82008	F81053-3	2	
29	WASHER, 6.5 ZINC FLAT	F81053-11	4	
30	KEY, AZ17/170-B5 SAFETY SWITCH	094422	1	
31	COVER, SAW HEAD MOUNT	096788-1	1	
32	BOLT, M6X12MM HEX HEAD ZINC	F81001-7	4	
33	WASHER, M6 FLAT ZINC	F81053-1	4	
34	CABLE, OLFLEX 400P 2X1	R80583-5	3m (DC) 5m (AC)	

### 4.7 Control Box (AC Sawmills)

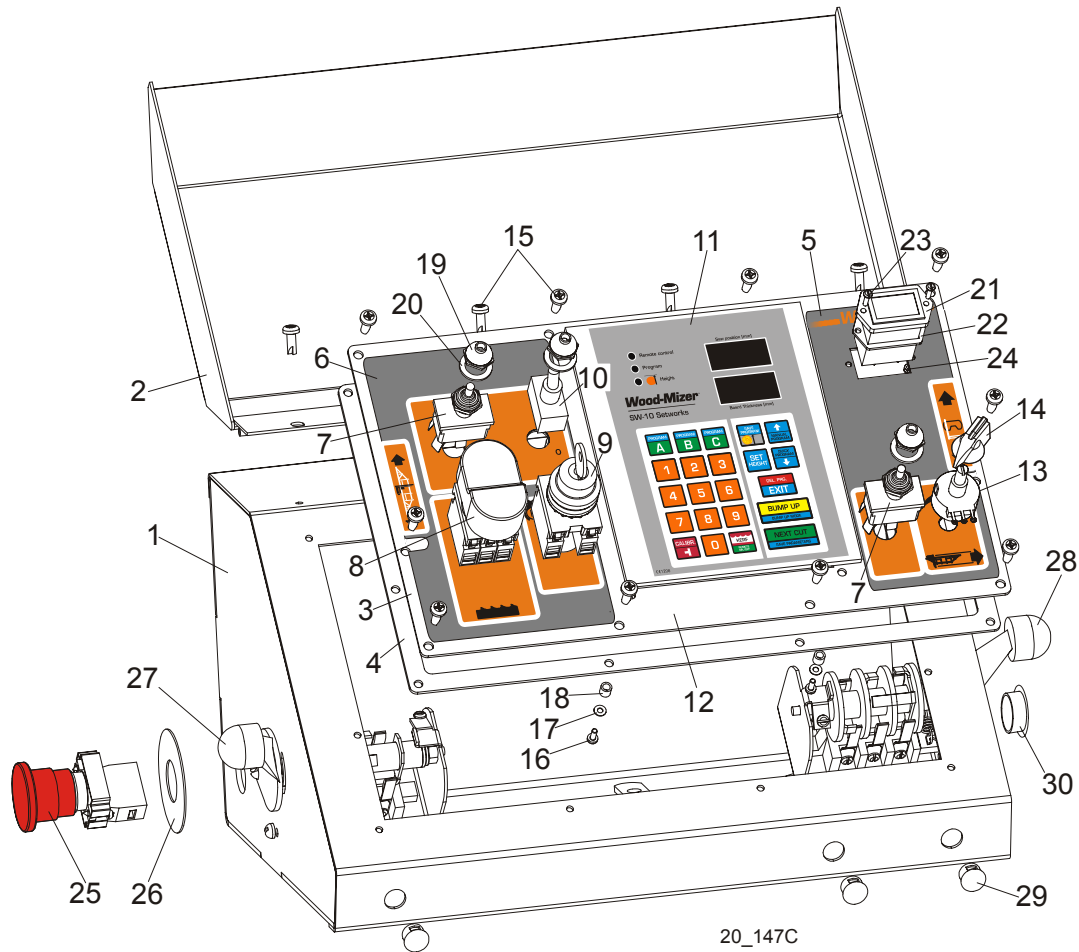

REF	DESCRIPTION (◆ Indicates Parts Available In Assemblies Only)	PART #	QTY.
	<b>CONTROL BOX ASSEMBLY, LT20 AC COMPLETE</b>	097136	1
1	Box Weldment, LT20 AC Control	097134-1	1
2	Cover Control Box, LT20	097135-1	1
3	Panel, LT20AC Front Control Complete	097131	1
4	Gasket, LT20 Control Box	097132	1
5	Decal, LT20AC/DC Control Box Right	099593	1
6	Decal, LT20AC Control Box Left	099594	1
7	Switch, DPDT Toggle 21A Rev Mom Spade	024200	2
8	Button, 24V Start/Stop	090452	1
	Membrane M22-T-DD	090462	1
9	Switch, M22 3-position Key	091361	1
	Contact, M22 - K10	091362	2
10	Switch, SPST ON/OFF 15A .25 Tabs Toggle	P03027	1
11	Controller, SW-10 Setworks	500628	1
12	Panel, LT20/40AC Front Control	100572-1	1
13	Potentiometer, 1K Feed Rate	E20519	1
14	Knob, Speed Control	P06257	1
15	Bolt, #10-24x1/2 Ph Pan Hd, Type 23	F05015-17	14

16	Screw, M3x8 -4.8- Fe/Zn5 PN-M/82202	F81000-83	6	
17	Washer, 3.2 Fe/Zn5 PN-M/82005	F81050-2	6	
18	Tube, 6mm 4.2 long	R80671-4	6	
19	Boot, Toggle Switch	P02575	3	
20	Washer, 1/2x3/4x1/16 Nylon	P05251-1	3	
21	Meter, Hour	093166	1	
22	Gasket, Hour Meter	093346	1	
23	Bolt, M3x12-8.8 Zinc	F81000-12	2	
24	Nut, M3-6 Hex Nylon Zinc Lock	F81028-2	2	
25	Button, XB4 BS542 Emergency Stop	086556	1	
26	Washer, Emergency Stop Switch	086561	1	
27	Switch, 1992GS Pwr/Feed (Service Package)	E20438	1	
28	Switch, 1992 Up/Down (Service Package)	E20440	1	
29	Cap, DP 812 Heyman 12.7 Dia. Hole	086773	3	
30	Cap, SR1086 22.2 Dia. Hole	093544	1	

### 4.8 Control Box (DC Sawmills)

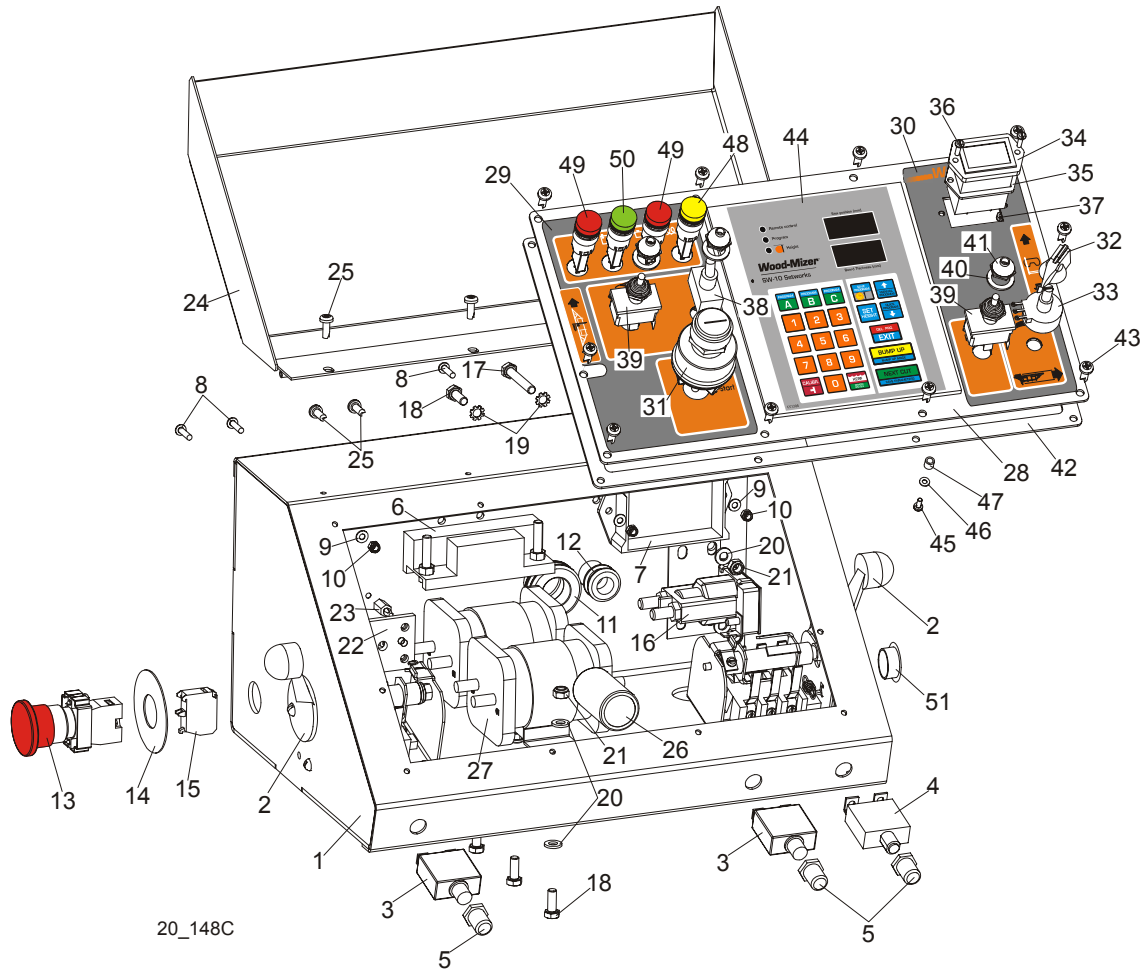

20\_148C

REF	DESCRIPTION (◆ Indicates Parts Available In Assemblies Only)	PART #	QTY.
	<b>CONTROL BOX ASSEMBLY, LT20 DC DIESEL COMPLETE</b>	097167	1
1	Box Weldment, LT20 DC	097165-1	1
2	Switch, 1992GS Pwr/Feed (Service Package)	E20438	2
3	Breaker, 50A Manual Reset Panel Mount	021256	2
4	Breaker, 30A Manual Reset Panel Mount	024246	1
5	Boot, Circuit Breaker	021253	3
6	Module Assy, Mosfet 4x 92-96 P/F	024540	1
7	Control Module Assy, P/F SMT Service '97	024396	1
8	Screw M4x16 5,8-B Zinc Lock	F81011-42	4
9	Washer, 4.3 Flat Zinc	F81051-2	4
10	Nut, M4-B Hex Nylon Zinc Lock	F81029-1	4
11	Grommet, 22mm Rubber	087400	1
12	Grommet, 20/13 Rubber	086188	1
13	Button, XB4 BS542 Emergency Stop	086556	1
14	Washer, ZBY9330 Emergency Stop Button	086561	1
15	Contact, ZBE102	086810	1
16	Solenoid, 120-943 Hyd Shut-Off	P10449	1
17	Bolt, M6x40mm, Hex Head, Full Thrd, Zinc	F81001-5	1

18	Bolt, M6x16mm, Hex Head, Full Thrd, Zinc	F81001-15	6	
19	Washer, M6 Star Lock Zinc	F81053-2	2	
20	Washer, M6 Flat Zinc	F81053-1	8	
21	Nut, M6 Hex Nylon Lock Zinc	F81031-2	5	
22	Radiator, Diode	091867	1	
23	Spacer, P3/12	R80671-2	4	
24	Cover Weldment, LT20 Complete	097135-1	1	
25	Bolt, #10-24x1/2 Ph Pan Hd, Type 23	F05015-17	6	
26	Capacitor, 10000/63V Elektrolytic	091166	1	
27	Solenoid, 200A 12V DPST	015417	2	
	Panel, LT20DC Front Complete	097163	1	
28	Panel, LT20/40DC Front	100573-1	1	
29	Decal, LT20DC Control Box Left	099592	1	
30	Decal, LT20AC/DC Control Box Right	099593	1	
31	Switch, Key	P04350	1	
32	Knob, Speed Control	P06257	1	
33	Potentiometer, 1k	E20519	1	
34	Meter, Hour	093166	1	
35	Gasket, Hour Meter	093346	1	
36	Bolt, M3x12-8.8 Zinc	F81000-12	2	
37	Nut, M3-6 Hex Nylon Zinc Lock	F81028-2	2	
38	Switch, SPST On/Off 15A .25 Tabs Toggle	P03027	1	
39	Switch, DPDT Toggle 21A Rev Mom Spade	024200	2	
40	Washer, 1/2x3/4x1/16 Nylon	P05251-1	3	
41	Boot, Toggle Switch	P02575	3	
42	Gasket, LT20 Control Box	097132	1	
43	Bolt, #10-24x1/2 Ph Pan Hd, Type 23	F05015-17	10	
44	Controller, SW-10 Networks	500628	1	
45	Screw, FH ST 3,5x6,5 A4	F81000-82	6	
46	Washer, 3.2 Flat Zinc	F81050-2	6	
47	Spacer, 4.2x6mm Idler	R80671-4	6	
48	Light, XB6AV5BB Yellow	089812	1	
49	Light, XB6AV4BB Red	091099	2	
50	Light, XB6AV3BB Green	087348	1	
51	Cap, SR1086 22.2 Dia. Hole	093544	1	



## 4.9 Drum Switches

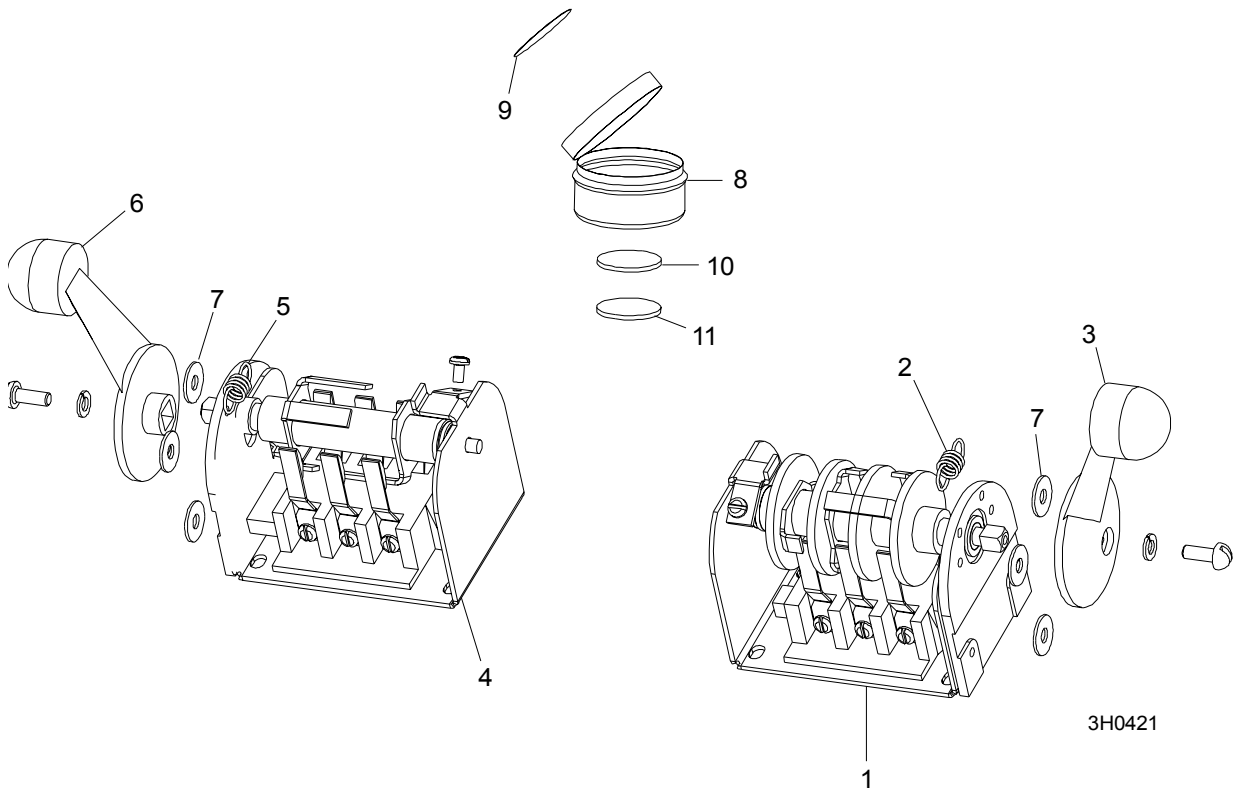

REF	DESCRIPTION (◆ Indicates Parts Available In Assemblies Only)	PART #	QTY.	
	<b>SWITCH ASSEMBLY, UP/DOWN DRUM</b>	E20440	1	
1	Switch, Drum	E20440-B	1	◆
2	Spring, Drum Switch	P12570	1	
3	Handle, Drum Switch w/Screws	P12500	1	
	<b>SWITCH ASSEMBLY, POWER FEED DRUM</b>	E20438	1	
4	Switch, Drum	E20438-B	1	◆
5	Spring, Drum Switch	P12570	1	
6	Handle, Drum Switch w/Screws	P12500	1	
7	<b>WASHER, #8 SAE FLAT</b>	F05011-41	6	
	<b>CUP ASSEMBLY, DRUM SWITCH GREASE</b>	A20463	1	
8	Cup, Plastic Container	P20464	1	◆
9	Label, Grease Cup	P20467	1	
10	Pad, Velcro Loop	P20466	1	◆
11	Pad, Velcro Hook	P20465	1	◆
	Grease, Drum Switch	P20468	.011ml	◆

**4.10 Sawdust Chute**

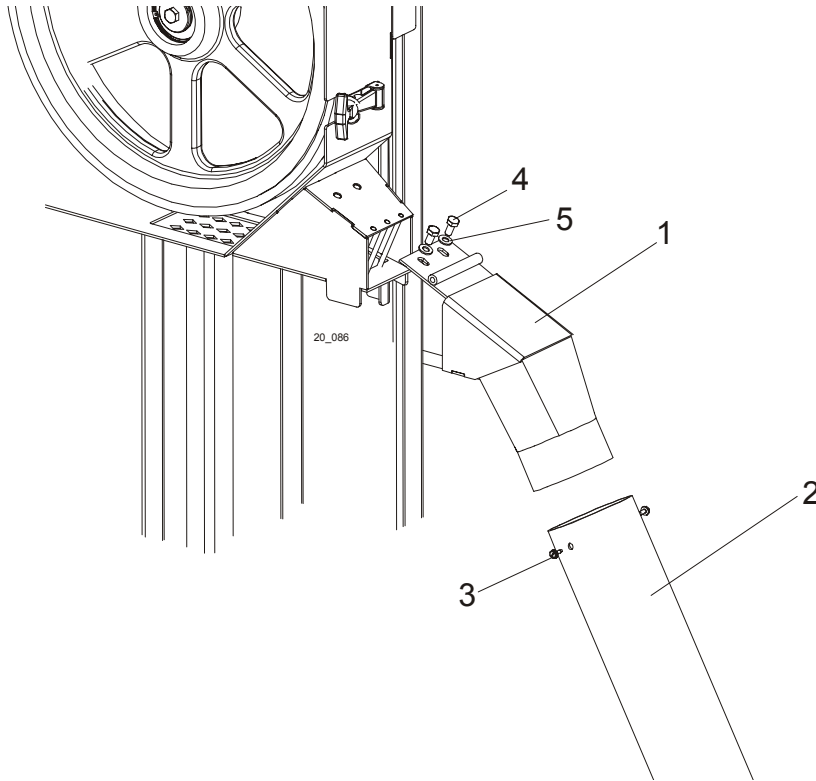

REF	DESCRIPTION (◆ Indicates Parts Available In Assemblies Only)	PART #	QTY.	
1	CHUTE WELDMENT, SAWDUST	100903-1	1	
2	TUBE, SAWDUST CHUTE RUBBER	R02336	1	
3	SCREW, #10-24 X 1/2 SELF-TAPPING	F05015-7	2	
4	BOLT, M8x16	F81002-20	2	
5	WASHER, 8.4 ZINC FLAT	F81054-1	2	

### 4.11 Up/Down Cable Chain Assembly

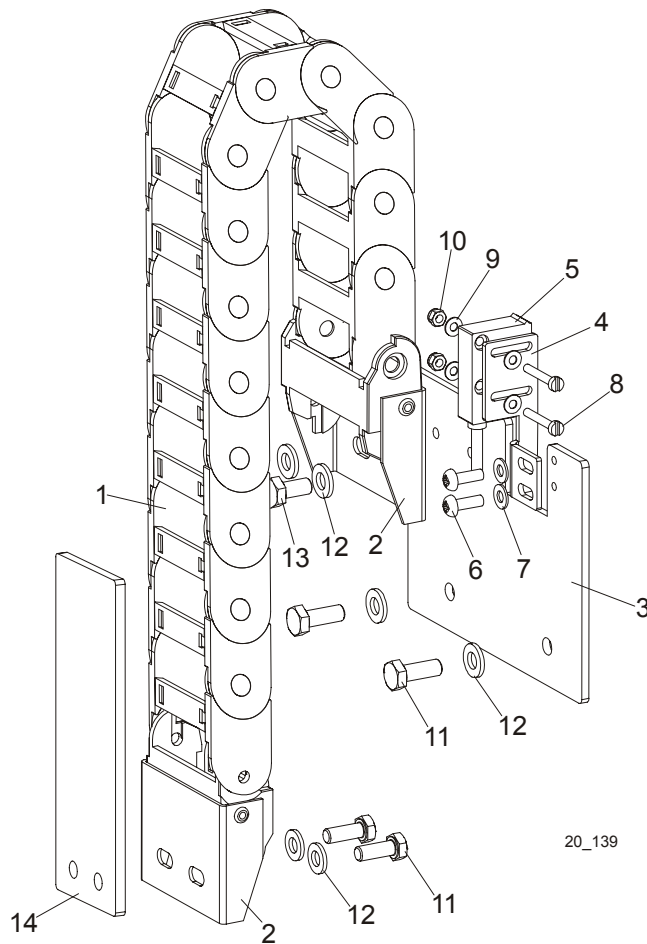

REF	DESCRIPTION (◆ Indicates Parts Available In Assemblies Only)	PART #	QTY.
	<b>HARNESS GUIDE AND SENSOR ASSEMBLY</b>	098052	1
1	Harness Guide, SR300A 050 080	097924	1
2	Bracket, AN300A 050K Mount	097925	1
3	Mounting Plate, Harness and Sensor Assy.	096067-1	1
4	Bracket, Sensor Mount	096068-1	1
5	Sensor, MSK-320	096014	1
6	Screw, M4x12-5,8-B Zinc	F81011-43	2
7	Washer, 4.3 Zinc	F81051-2	2
8	Screw, M3x20-5.8-A Zinc	F81000-8	2
9	Washer, 3.2 Zinc	F81050-2	4
10	Nut, M3-6 Zinc	F81028-2	2
11	Bolt, M6x20-8.8 Hex Head Zinc	F81001-2	4
12	Washer, 6.4 Zinc	F81053-1	6
13	Bolt, M6x12-8.8 Hex Head Zinc	F81001-7	2
14	Plate, Guide Mount	098662-1	1

4.12 LT20 Saw Head Rest Pin Assembly

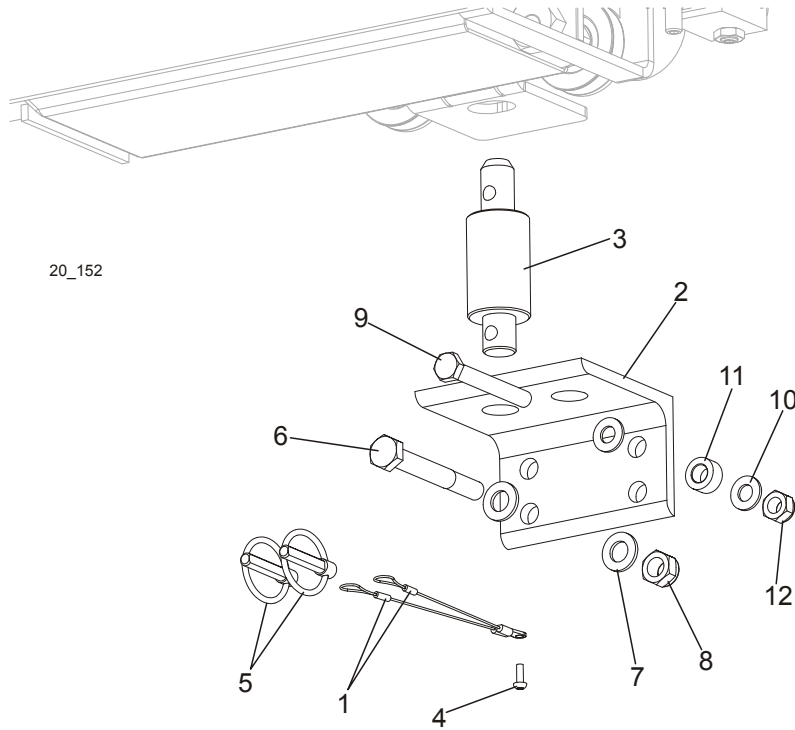

REF	DESCRIPTION (◆ Indicates Parts Available In Assemblies Only)	PART #	QTY.
	<b>BRACKET, LT20 SAW HEAD REST PIN COMPLETE</b>	097936	1
1	LANYARD, 3/64 X 6	016030	2
2	BRACKET, LT20 SAW HEAD REST PIN	091837-1	1
3	PIN, LT20 SAW HEAD REST	097935-1	1
4	SCREW, M4x12 5,8-B CROSS RECESSED PAN HEAD	F81011-43	1
5	PIN, 8 BN914 (BOSSARD 134650) LOCK	F81046-2	2
6	<b>BOLT, M12x95 -8.8- HEX HEAD ZINC-PLATED</b>	F81004-29	1
7	<b>WASHER, 13 FLAT ZINC</b>	F81056-1	2
8	<b>NUT, M12-8 HEX NYLON ZINC LOCK</b>	F81034-2	1
9	<b>BOLT, M10 X 80 -8.8- FE/ZN5 HEX HEAD</b>	F81003-50	1
10	<b>WASHER, 10.5 FLAT ZINC</b>	F81055-1	2
11	<b>BUSHING, ZINC-PLATED SPACER</b>	090936-1	1
12	<b>NUT, M10-8-B HEX NYLON ZINC LOCK</b>	F81033-1	1

## SECTION 5 UP/DOWN ASSEMBLY

### 5.1 Up/Down Assembly, AC Mills

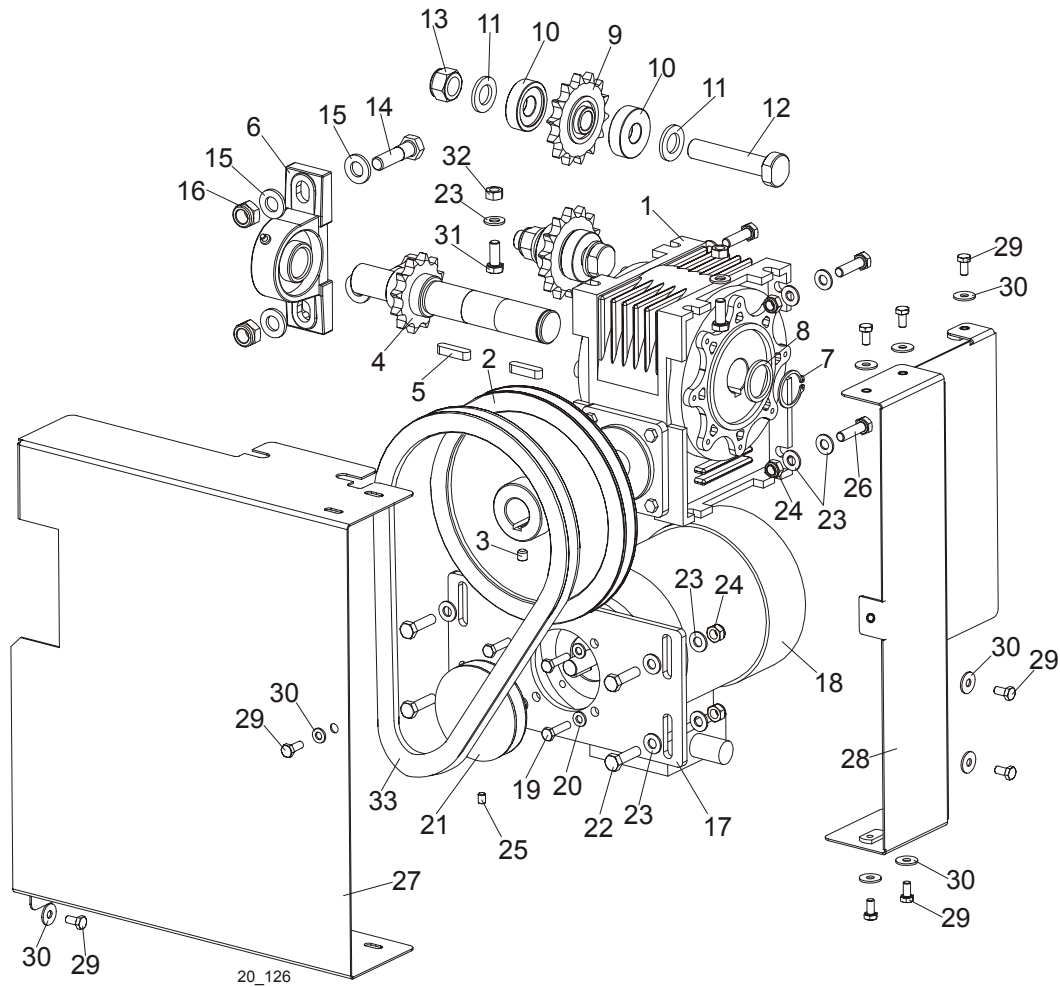

REF	DESCRIPTION (◆ Indicates Parts Available In Assemblies Only)	PART #	QTY.	
	<b>MOTOR ASSEMBLY, LT20 AC UP/DOWN</b>	098300	1	◆
	Motor Assembly, LT20 Up/Down	098299	1	
1	Box, R-63/66/F1/B3 Gear	097786	1	
2	Pulley, LT20	091078-1	1	
3	Screw, M8x8-33H Hex Socket Set Flat Point	F81014-1	1	
4	Shaft, LT20 Up/Down w/Sprocket	098298	1	
5	Key, A8x7x32 Parallel	088564	2	
6	Bearing Assembly, UCP 205CX	088468	1	
7	Ring, Z28 Spring Retaining	F81090-12	1	
8	Washer	098351	1	
	Shaft Assembly	098353	2	
9	Sprocket, KSR 16.LO.10.10.14.08 w/Bearing	088867	1	
10	Spacer, Drive Bearing	098166	2	
11	Washer, M16, Flat Zinc	F81058-1	2	
12	Pin, Up/Down Drive Shaft	098289-1	1	
13	Nut, M16, Hex, Nylon Zinc Lock	F81036-2	1	

14	Bolt, M12x45-8.8 Zinc Lock	F81004-32	2	
15	Washer, M12, Flat Zinc	F81056-1	4	
16	Nut, M12 ,Hexagon, Nylon, Zinc, Lock	F81034-2	2	
	Motor Assembly, LT20 AC Up/Down	091302	1	
17	Plate, LT20 AC Up/Down Motor Mount Ptd	098355-1	1	
18	Motor, SKh 71- 4B2 RAL 9005	091304	1	
19	Bolt, M6x25mm, Hex Head, Gr 8.8, Zinc	F81001-3	4	
20	Washer, M6, Flat Zinc	F81053-1	4	
21	Pulley, LT20 Gear Box	090699-1	1	
22	Bolt, M8x30mm,HH,Gr 5.8, Full Thrd, Zinc	F81002-2	4	
23	Washer, M8, Flat Zinc	F81054-1	18	
24	Nut, M8, Hexagon, Nylon Lock Zinc	F81032-2	8	
25	Screw, M6x8-33H Hex Socket Set Flat Point	F81013-1	1	
26	Bolt, M8x30-8.8-B-Fe/Zn5 PN-M82105	F81002-7	4	
27	Guard, Up/Down System Front	098393-1	1	
28	Guard, Up/Down System Side Complete	098395-1	1	
29	Bolt, M6x12mm Hex Head Zinc	F81001-7	9	
30	Washer, 6.5 Flat Special Zinc-Plated	F81053-11	9	
31	Bolt, M8x20mm,HH,GR 8.8, Full Thrd, Zinc	F81002-1	2	
32	Nut, M8 Hexagon, Grade 5.8 Free Zinc	F81032-1	2	
33	Belt, HA-800 (Kleberg)	091086	1	

## 5.2 Up/Down Assembly, DC Mills

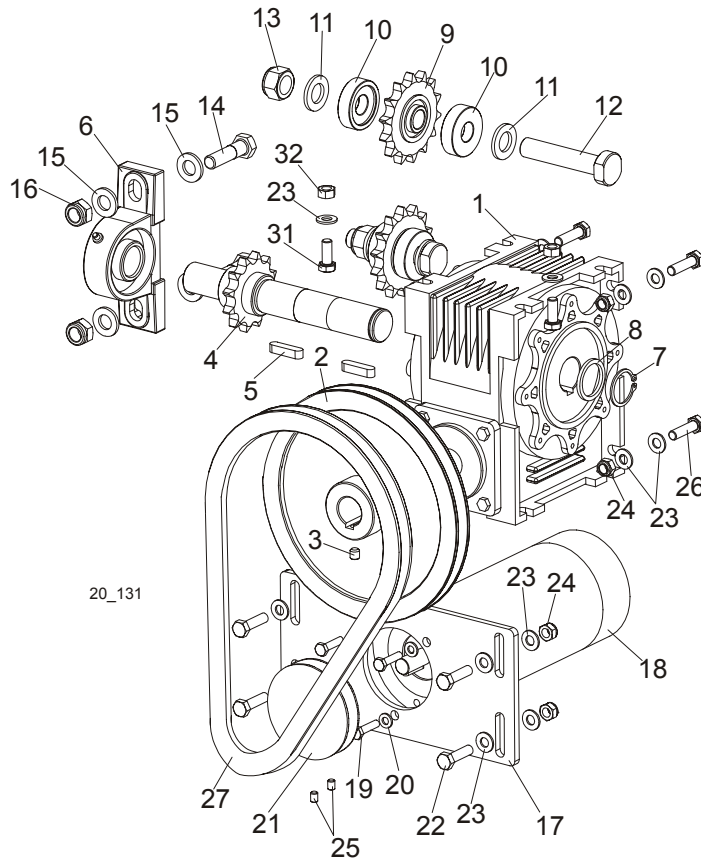

REF	DESCRIPTION (◆ Indicates Parts Available In Assemblies Only)	PART #	QTY.	
	<b>MOTOR ASSEMBLY, LT20 DC UP/DOWN</b>	098346	1	◆
	Motor Assembly, LT20 Up/Down	098299	1	
1	Box, R-63/66/F1/B3 Gear	097786	1	
2	Pulley, LT20	091078-1	1	
3	Screw, M8x8-33H Hex Socket Set Flat Point	F81014-1	1	
4	Shaft, LT20 Up/Down w/Sprocket	098298	1	
5	Key, A8x7x32 Parallel	088564	2	
6	Bearing Assembly, UCP 205CX	088468	1	
7	Ring, Z28 Spring Retaining	F81090-12	1	
8	Washer	098351	1	
	Shaft Assembly	098353	2	
9	Sprocket, KSR 16.LO.10.10.14.08 w/Bearing	088867	1	
10	Spacer, Drive Bearing	098166	2	
11	Washer, M16, Flat Zinc	F81058-1	2	
12	Pin, Up/Down Drive Shaft	098289-1	1	
13	Nut, M16, Hex, Nylon Zinc Lock	F81036-2	1	
14	Bolt, M12x45-8.8 Zinc Lock	F81004-32	2	
15	Washer, M12, Flat Zinc	F81056-1	4	
16	Nut, M12, Hexagon, Nylon, Zinc, Lock	F81034-2	2	
	Motor Assembly, LT20 AC Up/Down	091303	1	

17	Plate, LT20 DC Up/Down Motor Mount Ptd	098363-1	1	
18	Motor, 12V 0.5HP Drive	006747	1	
19	Bolt, 1/4-20x3/4 FT HHC	F05005-1	3	
20	Washer, M6, Flat Zinc	F81053-1	3	
21	Pulley, "A" 82/12,7 Gear Box	093158-1	1	
22	Bolt, M8x30mm,HH,Gr 5.8, Full Thrd, Zinc	F81002-2	4	
23	Washer, M8, Flat Zinc	F81054-1	18	
24	Nut, M8, Hexagon, Nylon Lock Zinc	F81032-2	8	
25	Screw, M6x8-33H Hex Socket Set Flat Point	F81013-1	2	
26	Bolt, M8x30-8.8-B-Fe/Zn5 PN-M82105	F81002-7	4	
27	Belt, HA-800 (Kleberg)	091086	1	



### 5.3 Up/Down Chain Tensioner Assembly

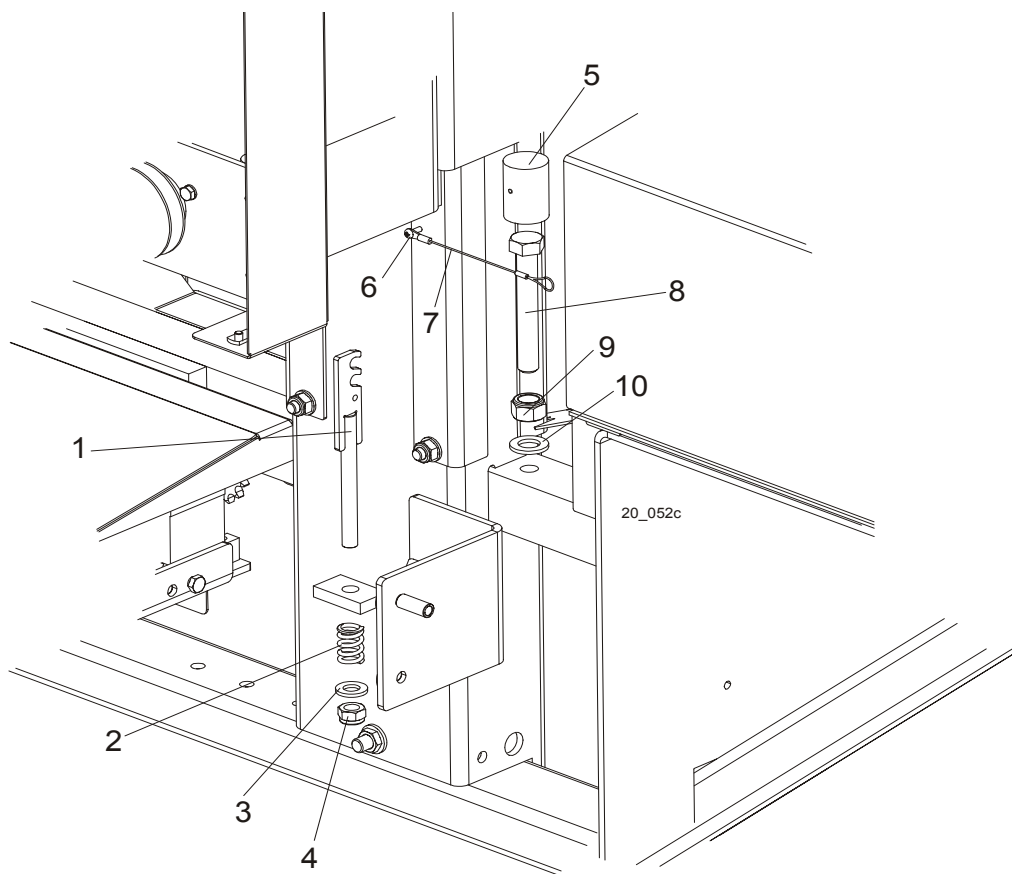

REF	DESCRIPTION (◆ Indicates Parts Available In Assemblies Only)	PART #	QTY.
1	<b>TENSIONER WELDMENT, LT20 UP/DOWN CHAIN ZINC-PLATED</b>	090730-1	1
2	<b>SPRING, 14 X 30 X 3.2</b>	090797	1
3	<b>WASHER, 13 ZINC FLAT</b>	F81056-1	1
4	<b>NUT, M12-8 HEX NYLON ZINC LOCK</b>	F81034-2	1
	<b>BLOCK, HEAD SUPPORTING, COMPLETE</b>	097775	1
5	Block, Head Support, ptd	097771-1	1
6	Screw M4x12 -5,8-B- Fe/Zn5 PN-M/82202	F81011-43	1
7	Lanyard, 3/64 x 6	016030	1
8	<b>BOLT M16X110-8.8</b>	F81006-24	1
9	<b>NUT, M16,HEX, NYLON ZINC LOCK</b>	F81036-2	1
10	<b>WASHER, M16,FLAT ZINC</b>	F81058-1	1
	<b>UP/DOWN CHAIN, LT20 TYPE 10B-1-111</b>	098451	1

**5.4 Battery Box Assembly, DC Mills**

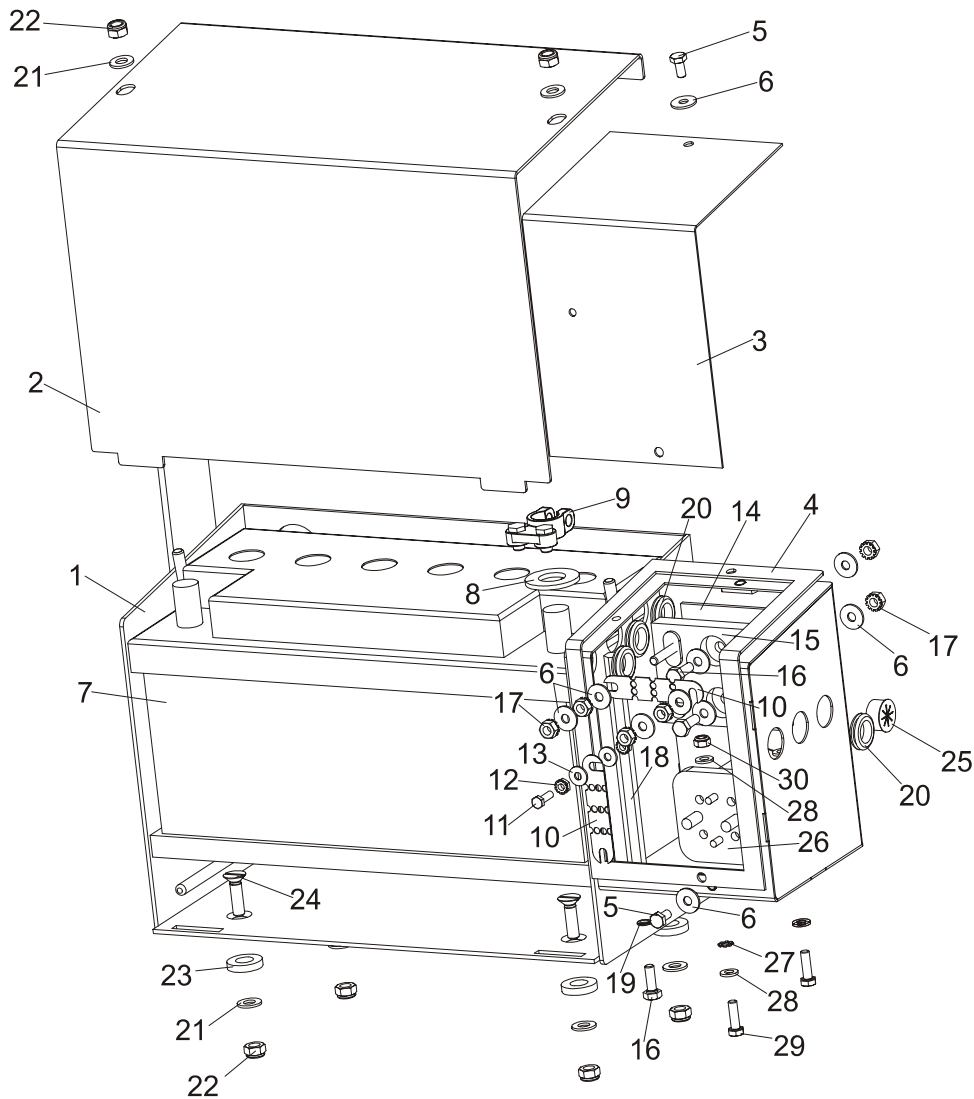

REF	DESCRIPTION (◆ Indicates Parts Available In Assemblies Only)	PART #	QTY.	
	<b>BATTERY BOX, LT20 COMPLETE</b>	<b>097490</b>	<b>1</b>	
1	Battery Box, LT20	097486-1	1	
2	Lid, Battery Box	097489-1	1	
3	Lid, Fuse Box	092222-1	1	
4	Gasket, Fuse Box	092226	1	
5	Bolt, M6x12mm Hex Head Zinc	F81001-7	2	
6	Washer, 6.5 Split Lock Zinc	F81053-11	10	
7	Battery, "Banner" 12V 100Ah #95751	088323	1	
8	Washer, Battery Terminal	P12161	1	
9	Terminal, Battery	P05085	1	
10	Fuse, 150A 12V Link	023361	2	
11	Screw, 10-24x5/8 Unsl Indent HH Machine	F05004-18	1	
12	Nut, #10-24 Keps	F05010-14	2	
13	Washer, 5.5 Split Lock Zinc	F81052-3	2	
14	Plate, 1/8 Plasic Fuse Box	015287	1	

<b>15</b>	Block Assy, Fuse, High Amp	017665	1	
<b>16</b>	Bolt, 1/4-20x3/4 FT HHC	F05005-1	3	
<b>17</b>	Nut, 1/4-20 Self Locking Zinc	F05010-9	6	
<b>18</b>	Nut, Fuse Stud Extended	015517	1	
<b>19</b>	Washer, M6 Split Lock Zinc	F81053-3	1	
<b>20</b>	Grommet, 5/8 ID Rubber	P11764	3	
	Grommet, SR170P No.462041	098816	1	
<b>21</b>	Washer, M8 Flat Zinc	F81054-1	6	
<b>22</b>	Nut, M8 Hexagon Nylon Lock Zinc	F81032-2	6	
<b>23</b>	Spacer, SR 1941 Idler	R80671-5	4	
<b>24</b>	Bolt, M8x30-5.8-B Zinc	F81002-37	4	
<b>25</b>	Grommet, Heyco Wire	P04137	1	
<b>26</b>	Solenoid, 200A 12V SPST Hyd. Pump 1997	015470	1	
<b>27</b>	Washer, M6 Star Lock Zinc	F81053-2	1	
<b>28</b>	Washer, M6 Flat Zinc	F81053-1	4	
<b>29</b>	Bolt, M6x20mm, HH, Full Thread, Zinc	F81001-2	2	
<b>30</b>	Nut, M6 Hex Nylon Lock Zinc	F81031-2	2	

# SECTION 6 UP/DOWN ROLLERS & BLADE HEIGHT SCALE

## 6.1 Up/Down Rollers

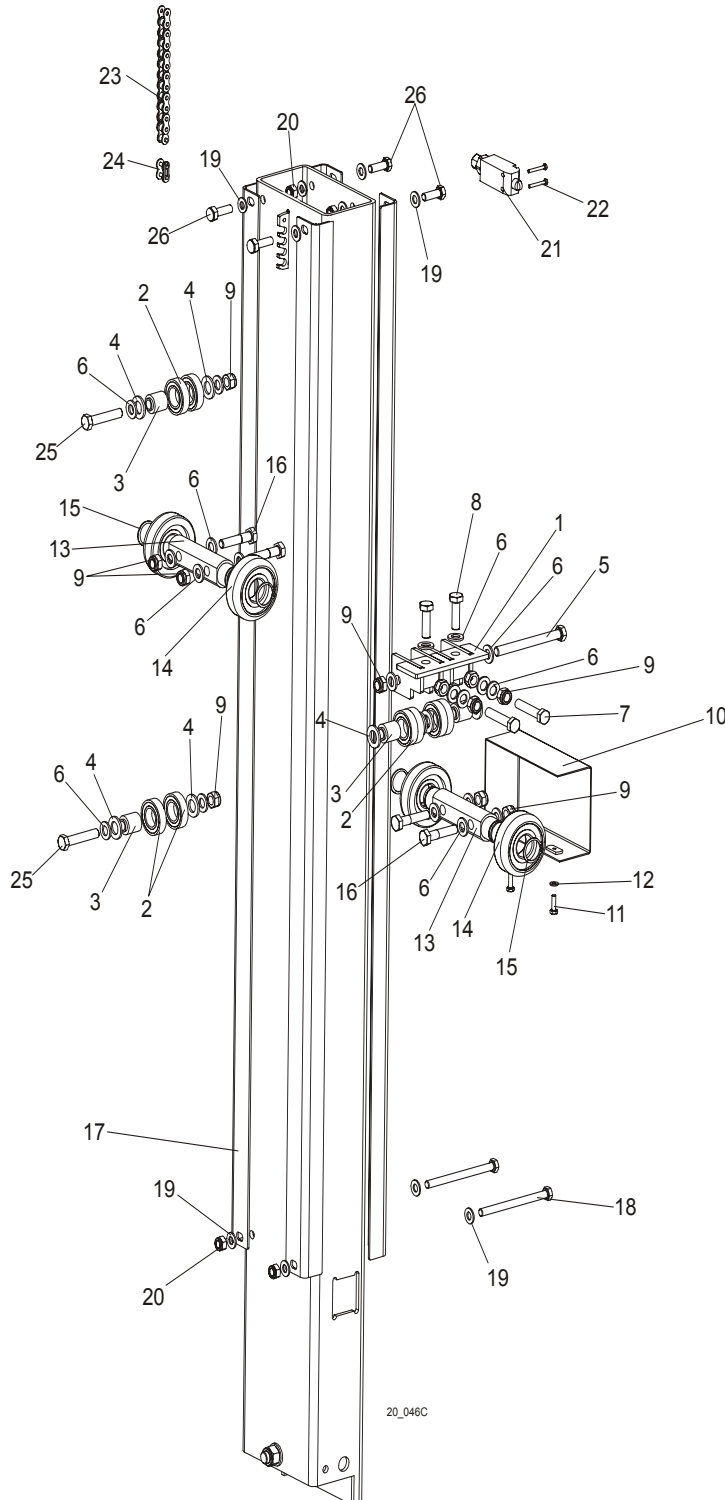

REF	DESCRIPTION (◆ Indicates Parts Available In Assemblies Only)	PART #	QTY.
1	BRACKET WELDMENT, LT20 UP/DOWN ROLLER PTD	091095-1	1
2	BEARING, 6005 2RS CX	089652	8

3	BUSHING, LT20 UP/DOWN ROLLER	090790	4	
4	WASHER, 17 ZINC FLAT	F81058-1	10	
5	BOLT, M12 X 120 8.8 HEX HEAD ZINC	F81004-38	1	
6	WASHER, 13 ZINC FLAT	F81056-1	20	
7	BOLT, M12 X 60-8.8 HEX HEAD FULL THREAD ZINC	F81004-51	2	
8	BOLT, M12 X 40-8.8 HEX HEAD FULL THREAD ZINC	F81004-4	2	
9	NUT, M12-8 HEX NYLON ZINC LOCK	F81034-2	11	
10	GUARD, LT20 UP/DOWN ROLLERS PTD	091619-1	1	
11	BOLT, M6 X 20-8.8 HEX HEAD FULL THREAD ZINC	F81001-2	2	
12	WASHER, 6.4 ZINC FLAT	F81053-1	2	
13	SHAFT, UP/DOWN ROLLERS ZINC-PLATED	090616-1	2	
14	ROLLER, CBK-468	088433	4	
15	RING, Z30 SPRING RETAINING	F81090-23	4	
16	BOLT, M12 X 55-8.8 HEX HEAD FULL THREAD ZINC	F81004-43	4	
17	ANGLE, LT20 MAST TUBE	091182	4	
18	BOLT, M10 X 125-8.8 HEX HEAD ZINC	F81003-18	2	
19	WASHER, 10.5 ZINC FLAT	F81055-1	22	
20	NUT, M10-8-B HEX NYLON ZINC LOCK	F81033-1	10	
21	SWITCH, GLCB01C LIMIT	100910	1	
22	BOLT, M4 X 30 8.8 HEX HEAD FULL THREAD ZINC	F81011-5	2	
23	CHAIN, LT20 10B-1-111 TYPE UP/DOWN	098451	1	
24	LINK, 10B-1PZ MASTER	088671	1	
25	BOLT, M12X60MM, HEX HEAD GR 8.8	F81004-5	2	
26	BOLT, M10X25-8.8-FE/ZN5	F81003-11	4	

6.2 Blade Height Scale

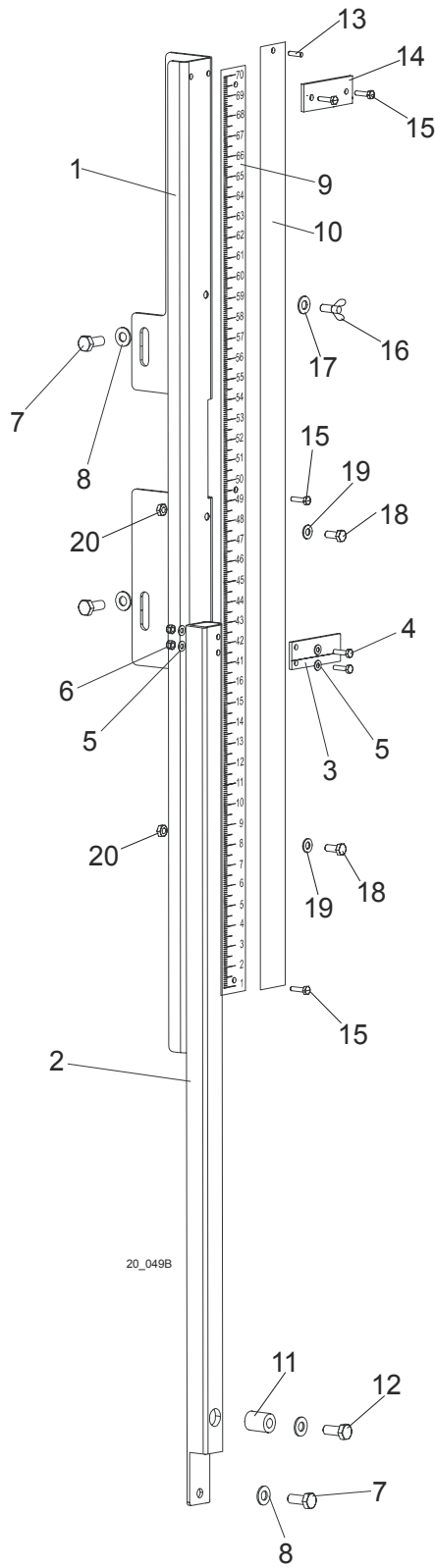

REF	DESCRIPTION (◆ Indicates Parts Available In Assemblies Only)	PART #	QTY.	
1	BRACKET, SCALE MOUNT PTD	092749-1	1	
2	BRACKET, SCALE INDICATOR MOUNT PTD	092751-1	1	

3	INDICATOR, BLADE HEIGHT SCALE	094821	1	
4	BOLT, M4 X 16 5.8 HEX HEAD FULL THREAD ZINC	F81011-6	2	
5	WASHER, 4.3 ZINC FLAT	F81051-2	4	
6	NUT, M4-B HEX NYLON ZINC LOCK	F81029-1	2	
7	BOLT, M8 X 20-5.8 HEX HEAD FULL THREAD ZINC	F81002-1	4	
8	WASHER, 8.4 ZINC FLAT	F81054-1	4	
9	BAR, SCALE	092750	1	
	DECAL, LT20 0-80CM METRIC SCALE	091239	1	
10	BAR, INCH SCALE	093133	1	
	DECAL, 45-63CM METRIC	P12040-2	1	
	DECAL, METRIC 16-40MM	P12040-1	1	
11	BUSHING, SPACER	092008-1	1	
12	BOLT, M8 X 45 - 8.8 Fe/Zn5, PN-M/82105	F81002-14	1	
13	PIN, 3x20 ROLL ZINC	F81044-5	1	
14	BAR, SCALE MOUNT	093134	1	
15	SCREW, M6x20- 4.8-B Fe/Zn5 PN-85/M-82207	F81001-31	1	
16	BOLT, M6X16 BN276	F81001-16	1	
17	WASHER, FLAT ZINC	F81053-11	1	
18	BOLT, M6X20MM, HH, FULL THREAD, ZINC	F81001-2	2	
19	WASHER, M6, FLAT,ZINC	F81053-1	2	
20	NUT, M6, HEX,NYLON LOCK ZINC	F81031-2	2	

6.3 Limit Switches

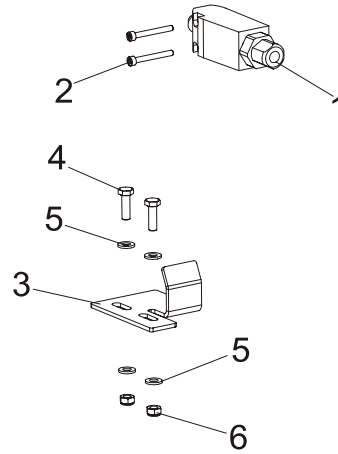

20\_133

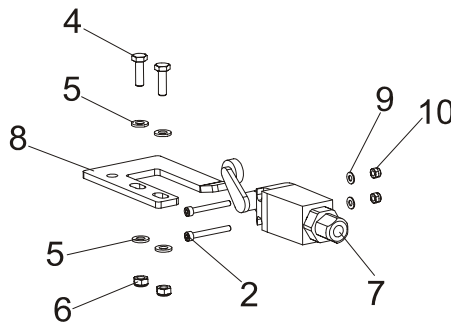

REF	DESCRIPTION (◆ Indicates Parts Available In Assemblies Only)	PART #	QTY.
1	SWITCH, GLCB01C LIMIT	100910	1
2	SCREW, M4x35-8.8 HEX SOCKET HEAD CAP ZINC	F81011-34	4
3	BRACKET, LIMIT SWITCH	091682-1	1
4	BOLT, M6X20MM, HH, FULL THREAD, ZINC	F81001-2	4
5	WASHER, M6 FLAT ZINC	F81053-1	8
6	NUT, M6 HEX NYLON LOCK ZINC	F81031-2	4
7	SWITCH, GLCB01A1B LIMIT	100931	1
8	BRACKET, LIMIT SWITCH	091852-1	1
9	WASHER, M4 FLAT ZINC	F81051-2	2
10	NUT, M4 HEX NYLON LOCK ZINC	F81029-1	2



## SECTION 7 POWER FEED & TRACK ROLLERS

### 7.1 Power Feed Assembly, AC Mills

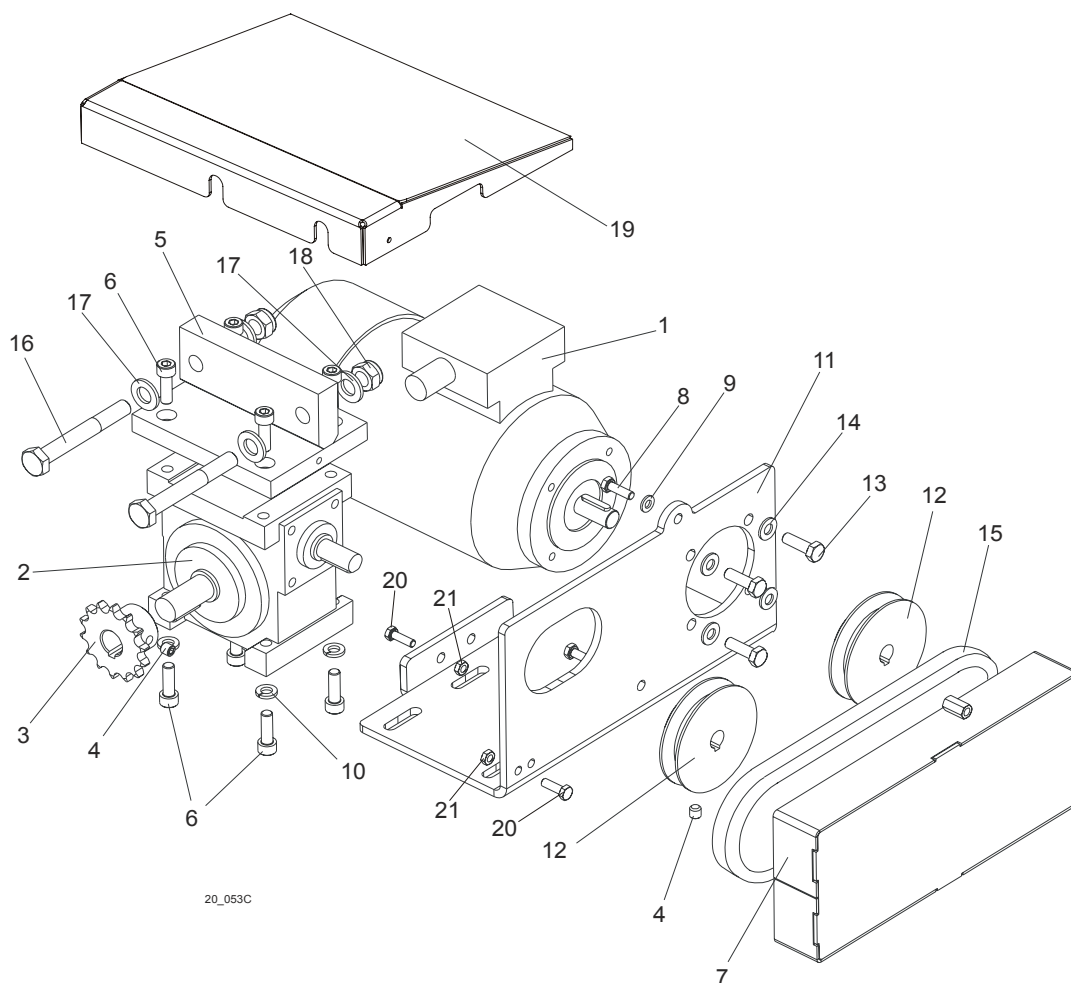

20\_053C

REF	DESCRIPTION (◆ Indicates Parts Available In Assemblies Only)	PART #	QTY.
	<b>POWER FEED ASSEMBLY, LT20 AC</b>	091196	1
1	Motor, Kh71X-2C2, RAL 9005	097313	1
2	Gear Box, RA-04/7.5/D1/N+S/B8 w/Output Shaft	090698	1
3	Sprocket, 08B Z14 Zinc-plated	090702-1	1
4	Screw, M8x8-33H Hex Socket Set Flat Point Zinc	F81014-1	1
5	Bracket, Power Feed Gear Box Mount	090715-1	1
6	Screw, M8X25-8.8 Hex Socket Head Cap Zinc	F81002-21	4
7	Guard, Power Feed Drive Belt	091195-1	1
8	Bolt, M6x20-8.8 Hex Head Full Thread Zinc	F81001-2	2
9	Washer, 6.4 Zinc Flat	F81053-1	2
10	Washer, 8.2 Split Lock Zinc	F81054-4	4
11	Bracket, Power Feed Gear Box	091191	1
12	Pulley, LT20 Power Feed Gear Box Ptd	090699-1	2
13	Bolt, M8x25-8.8-B Hex Head Full Thread Zinc	F81002-5	4
14	Washer, 8.4 Zinc Flat	F81054-1	4
15	V-Belt, HA-560 (STOMIL-SANOK)	088562	1

16	<b>BOLT, M12X90-8.8 HEX HEAD ZINC</b>	F81004-2	2	
17	<b>WASHER, 13 ZINC FLAT</b>	F81056-1	4	
18	<b>NUT, M12-8 HEX NYLON ZINC LOCK</b>	F81034-2	2	
19	<b>GUARD, POWER FEED MOTOR</b>	093780-1	1	
20	<b>BOLT, M8 x 25mm HEX HEAD GR 5.8 ZINC</b>	F81002-5	2	
21	<b>NUT, M8 HEXAGON, GRADE 5.8 FREE ZINC</b>	F81032-1	2	

## 7.2 Power Feed Assembly, DC Mills

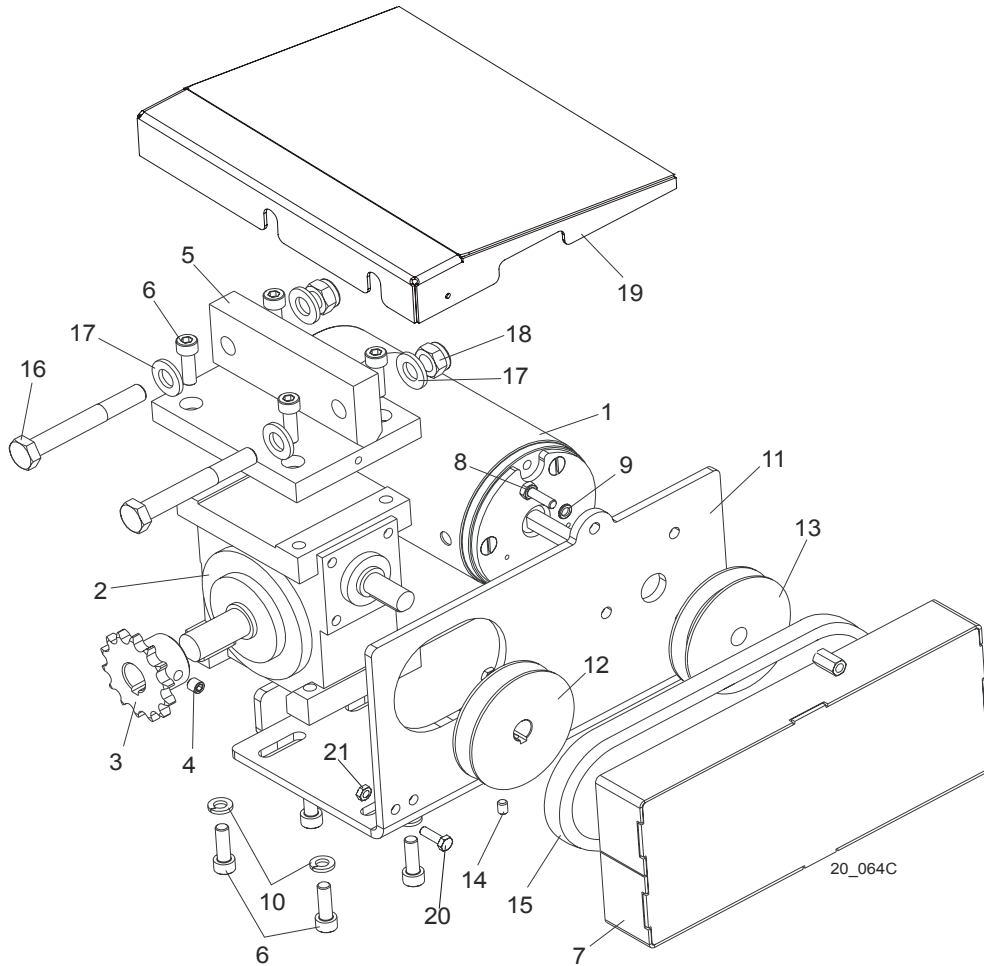

REF	DESCRIPTION (◆ Indicates Parts Available In Assemblies Only)	PART #	QTY.
	<b>POWER FEED ASSEMBLY, LT20 DC</b>	090703	1
1	Motor, 12V 0.5HP	006747	1
2	Gear Box, RA-04/7.5/D1/N+S/B8 w/Output Shaft	090698	1
3	Sprocket, 10B Z14 Zinc-plated	090702-1	1
4	Screw, M8x8-33H Hex Socket Set Flat Point Zinc	F81014-1	1
5	Bracket, Power Feed Gear Box Mount	090715-1	1
6	Screw, M8X25-8.8 Hex Socket Head Cap Zinc	F81002-21	4
7	Guard, Power Feed Drive Belt	091195-1	1
8	Bolt, M6x20-8.8 Hex Head Full Thread Zinc	F81001-2	2
9	Washer, 6.4 Zinc Flat	F81053-1	2
10	Washer, 8.2 Split Lock Zinc	F81054-4	4
11	Bracket, LT20 Power Feed Motor Mount Ptd	090701-1	1
12	Pulley, LT20 Power Feed Gear Box Ptd	090699-1	2
13	Sheave, Up/Down Motor "A" 82/12.7 Ptd	093158-1	1
14	Screw, M6x8 Hex Socket Set Cone Point Zinc	F81013-1	1
15	V-Belt, HA-560 (STOMIL-SANOK)	088562	1
16	<b>BOLT, M12X90-8.8 HEX HEAD ZINC</b>	F81004-2	2
17	<b>WASHER, 13 ZINC FLAT</b>	F81056-1	4
18	<b>NUT, M12-8 HEX NYLON ZINC LOCK</b>	F81034-2	2

19	<b>GUARD, POWER FEED MOTOR</b>	093780-1	1	
20	<b>BOLT, M8 x 25mm HEX HEAD GR 5.8 ZINC</b>	F81002-5	2	
21	<b>NUT, M8 HEXAGON, GRADE 5.8 FREE ZINC</b>	F81032-1	2	

### 7.3 Upper Track Rollers And Wipers

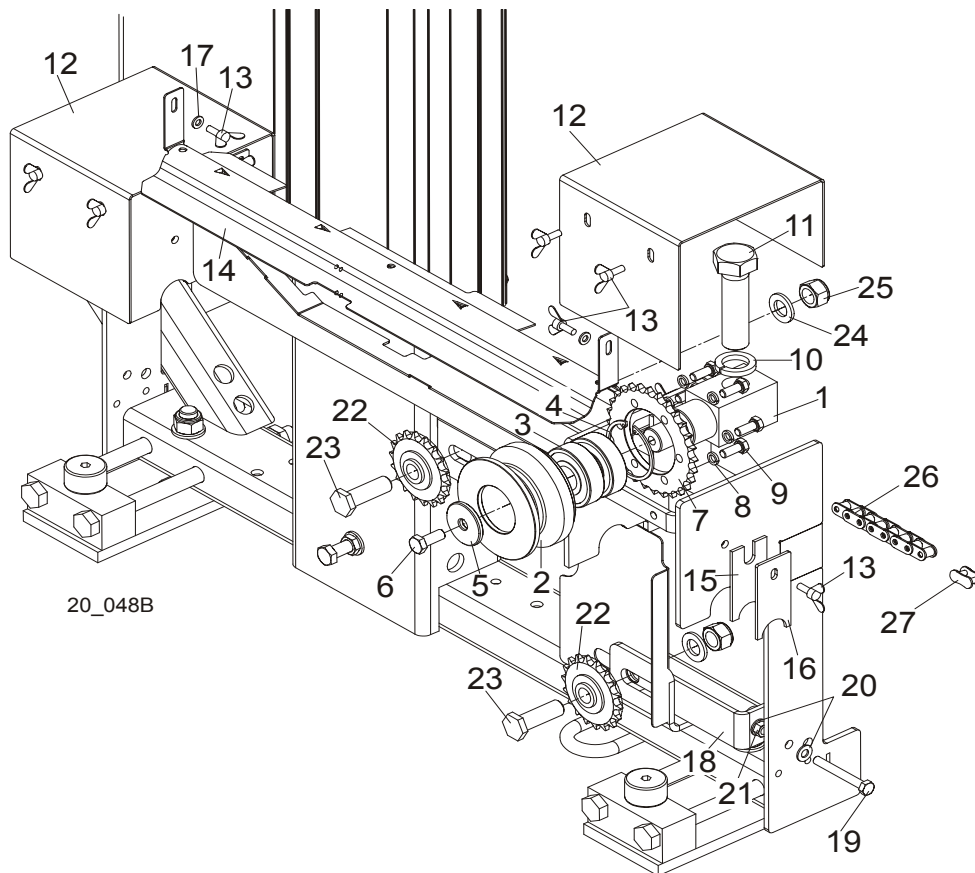

REF	DESCRIPTION (◆ Indicates Parts Available In Assemblies Only)	PART #	QTY.
	<b>ROLLER ASSEMBLY, LT20 UPPER TRACK</b>	090662	2
1	Block, Upper Track Roller Mount	090665	1
2	Roller, Upper Track	090663	1
3	Bearing, 6305 2RS NSK	P08066	2
4	Ring, 2 7/16" Bevelled Snap	F04254-21	1
5	Washer, Drive Wheel	086286	1
6	Bolt, M10x25-8.8 Hex Head Full Thread Zinc	F81003-11	1
7	Sprocket, O8B Z28	090664	2
8	Washer, 8.2 Split Lock Zinc	F81054-4	6
9	Bolt, M8x20-5.8 Hex Head Full Thread Zinc	F81002-1	6
10	<b>WASHER, Z 24.5 SPLIT LOCK ZINC</b>	F81061-4	2
11	<b>BOLT, M24X2X90-8.8 HEX HEAD FULL THREAD ZINC</b>	F81009-2	2
12	<b>GUARD, UPPER TRACK ROLLER</b>	090749-1	2
13	<b>SCREW, M6 X 16 BN276 DIN 316 THUMB</b>	F81001-16	8
14	<b>COVER, LT20 MIDDLE TRACK W/FELT - SERVICE</b>	091656-S	1
	Cover, LT20 Middle Track Ptd	091656-1	1
	Strip, 3/16 X 2 X 23 Felt	S09915	1
15	<b>WIPER, TOP RAIL</b>	M04113	2
16	<b>PLATE, TRACK WIPER PTD</b>	088559-1	2
17	<b>WASHER, 6.4 ZINC FLAT</b>	F81053-1	2

18	TENSIONER, POWER FEET SPROCKET	092862-1	1	
19	BOLT, M8 X 65MM,HH,GRADE 5.8, ZINC	F81002-3	1	
20	WASHER, M8, FLAT, ZINC	F81054-1	2	
21	NUT, M8 HEXAGON,GRADE 5.8 FREE ZINC	F81032-1	1	
22	SPROCKET, IDLER Z=18 KSR16.L0.08.10.18.0	088700	2	
23	BOLT, SPROCKET MOUNT	091744-1	2	
24	WASHER, 17 FLAT ZINC	F81058-1	2	
25	NUT, M16,HEX, NYLON ZINC LOCK	F81036-2	2	
26	CHAIN, LT20 08B-185 TYPE POWER FEED	091624	1	
27	LINK, 08B-1PZ MASTER	091625	1	

### 7.4 Lower Track Rollers

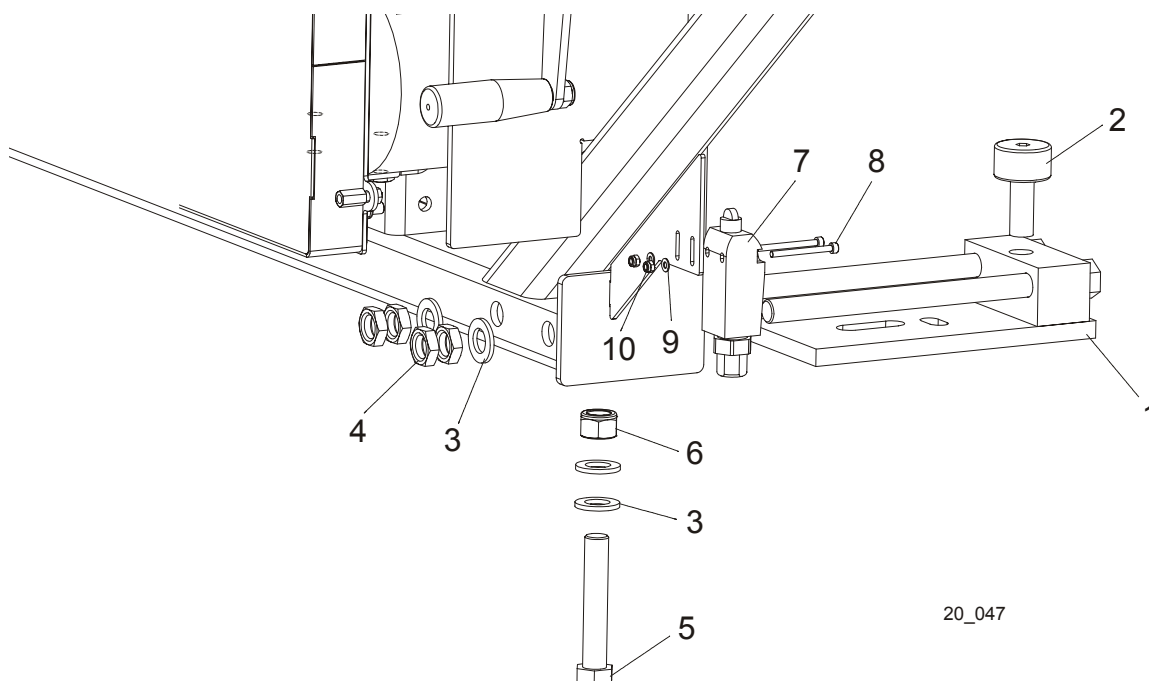

REF	DESCRIPTION (◆ Indicates Parts Available In Assemblies Only)	PART #	QTY.
	<b>ROLLER ASSEMBLY, LT20 LOWER TRACK</b>	090670	2
1	Bracket, LT20 Lower Track Roller	090671-1	1
2	Bearing, Cam Follower (McGill)	012797	1
3	<b>WASHER, 17 ZINC FLAT</b>	F81058-1	4
4	<b>NUT, M16 HEX THIN ZINC</b>	F81036-4	4
5	<b>BOLT, M16 X 90-8.8 HEX HEAD ZINC</b>	F81006-17	1
6	<b>NUT, M16-8 HEX NYLON ZINC LOCK</b>	F81036-2	1
7	<b>SWITCH, GLCB01A1B LIMIT</b>	100931	1
8	<b>SCREW, M4 X 45-8.8 HEX SOCKET HEAD CAP ZINC</b>	F81011-33	2
9	<b>NUT, M4-B HEX NYLON ZINC LOCK</b>	F81029-1	2
10	<b>WASHER, 4.3 ZINC FLAT</b>	F81051-2	2

**SECTION 8 BED FRAME ASSEMBLY**

**8.1 Bed Rail Assembly, Front (S/M type frame)**

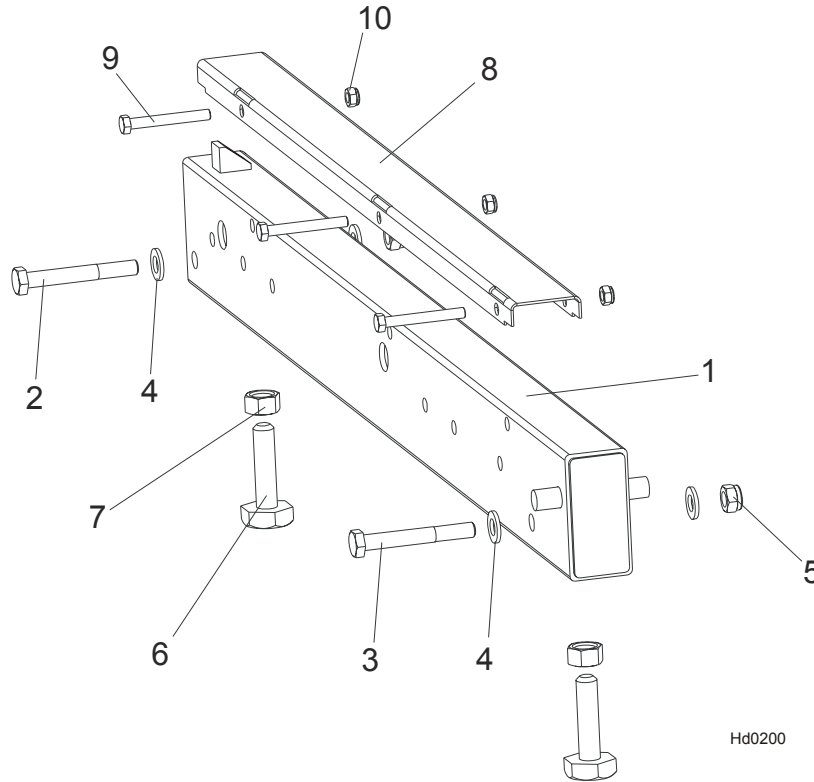

REF	DESCRIPTION (◆ Indicates Parts Available In Assemblies Only)	PART #	QTY.
1	<b>BED RAIL ASSEMBLY, FRONT (S&amp;M FRAME)</b>	099955	1
2	Bolt, M12 x 90-8.8 Hex Head	F81004-2	1
3	Bolt, M12 x 95-8.8 Hex Head	F81004-29	1
4	Washer, 13 SAE Flat	F81056-1	4
5	Nut, M12-8 Hex Nylon Lock	F81034-2	2
	Bed Rail Bolt, Complete (M16 Bolt + 2xNut)	093710	2
6	Bolt, M16, Bed Rail Adjustment	086809	1
7	Nut, M16-5-B Zinc Hex Head	F81036-5	2
8	<b>COVER, STAINLESS STEEL BED RAIL</b>	099124	1
9	<b>BOLT, M8X65-5,8 ZINC HEX HEAD</b>	F81002-3	3
10	<b>NUT, M8-8-B-ZINC HEX NYLON LOCK</b>	F81032-2	3



8.2 Bed Rail Assembly, Rear (S/M type frame)

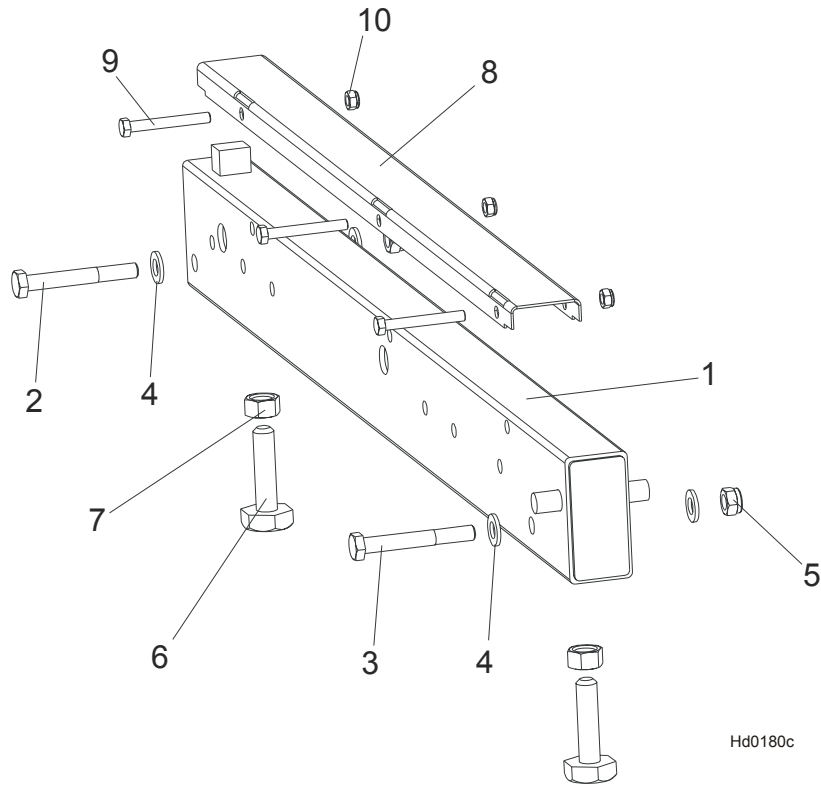

REF	DESCRIPTION (◆ Indicates Parts Available In Assemblies Only)	PART #	QTY.
1	<b>BED RAIL ASSEMBLY, REAR PAINTED</b>	091555	1
2	Bolt, M12 x 90-8.8 Hex Head	F81004-2	1
3	Bolt, M12 x 95-8.8 Hex Head	F81004-29	1
4	Washer, 13 SAE FLAT	F81056-1	4
5	Nut, m12-8 Hex Nylon Lock	F81034-2	2
	Bed Rail Bolt, Complete (M16 Bolt + 2xNut)	093710	1
6	Bolt, M16, Bed Rail Adjustment	086809	1
7	Nut, M16-5-B Zinc Hex Head	F81036-5	2
8	<b>COVER, STAINLESS STEEL BED RAIL</b>	099124	1
9	<b>BOLT, M8X65-5,8 ZINC HEX HEAD</b>	F81002-3	3
10	<b>NUT, M8-8-B-ZINC HEX NYLON LOCK</b>	F81032-2	3

**8.3 Bed Rail Assembly, Front Middle (S/M type frame)**

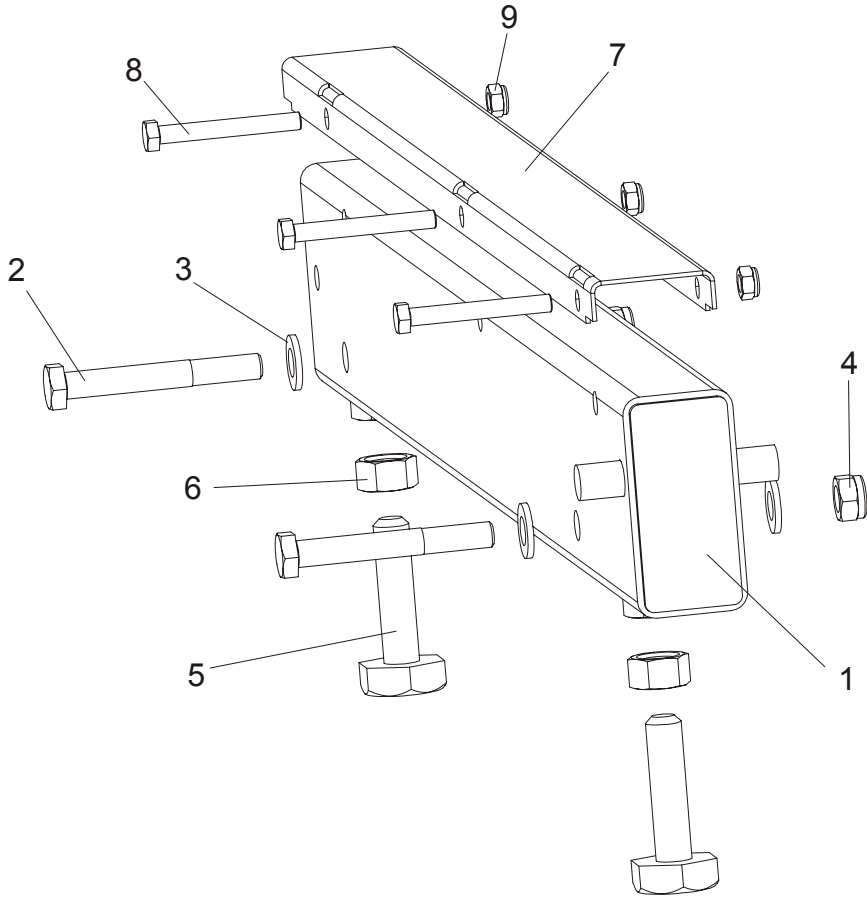

REF	DESCRIPTION (◆ Indicates Parts Available In Assemblies Only)	PART #	QTY.
1	<b>BED RAIL ASSEMBLY, FRONT MIDDLE</b>	091556	1
2	Bolt, M12 x 90-8.8 Hex Head	F81004-2	2
3	Washer, 13 SAE Flat	F81056-1	4
4	Nut, M12-8 hex Nylon Lock	F81034-2	2
	Bed Rail Bolt, Complete (M16 Bolt + 2xNut)	093710	2
5	Bolt, M16, Bed Rail Adjustment	086809	1
6	Nut, M16-5-B Zinc Hex Head	F81036-5	2
7	<b>COVER, STAINLESS STEEL BED RAIL</b>	099124	2
8	<b>BOLT, M8X65-5,8 ZINC HEX HEAD</b>	F81002-3	3
9	<b>NUT, M8-8-B-ZINC HEX NYLON LOCK</b>	F81032-2	3

8.4 Bed Rail Assembly, Rear Middle (S/M type frame)

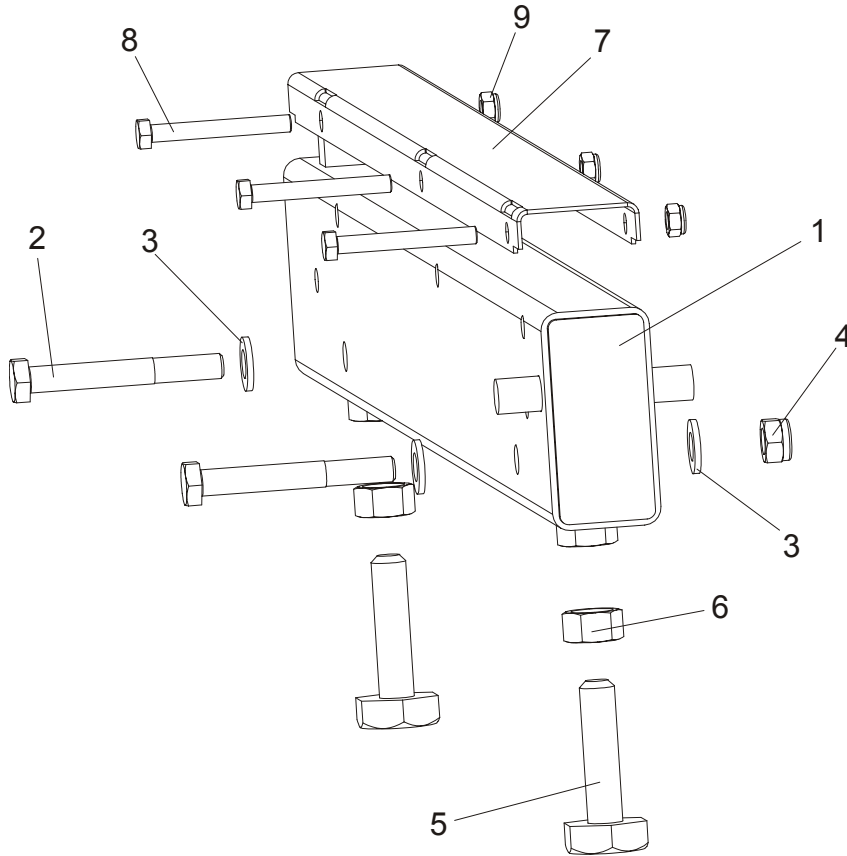

REF	DESCRIPTION (◆ Indicates Parts Available In Assemblies Only)	PART #	QTY.
1	<b>BED RAIL ASSEMBLY, REAR MIDDLE PAINTED</b>	091557	1
2	Bolt, M12 x 90-8.8 Hex Head	F81004-2	2
3	Washer, 13 SAE Flat	F81056-1	4
4	Nut, M12-8 hex Nylon Lock	F81034-2	2
	Bed Rail Bolt, Complete (M16 Bolt + 2xNut)	093710	2
5	Bolt, M16, Bed Rail Adjustment	086809	1
6	Nut, M16-5-B Zinc Hex Head	F81036-5	2
7	<b>COVER, STAINLESS STEEL BED RAIL</b>	099124	1
8	<b>BOLT, M8X65-5,8 ZINC HEX HEAD</b>	F81002-3	3
9	<b>NUT, M8-8-B-ZINC HEX NYLON LOCK</b>	F81032-2	3

**8.5 Bed Rail Assembly (L type frame)**

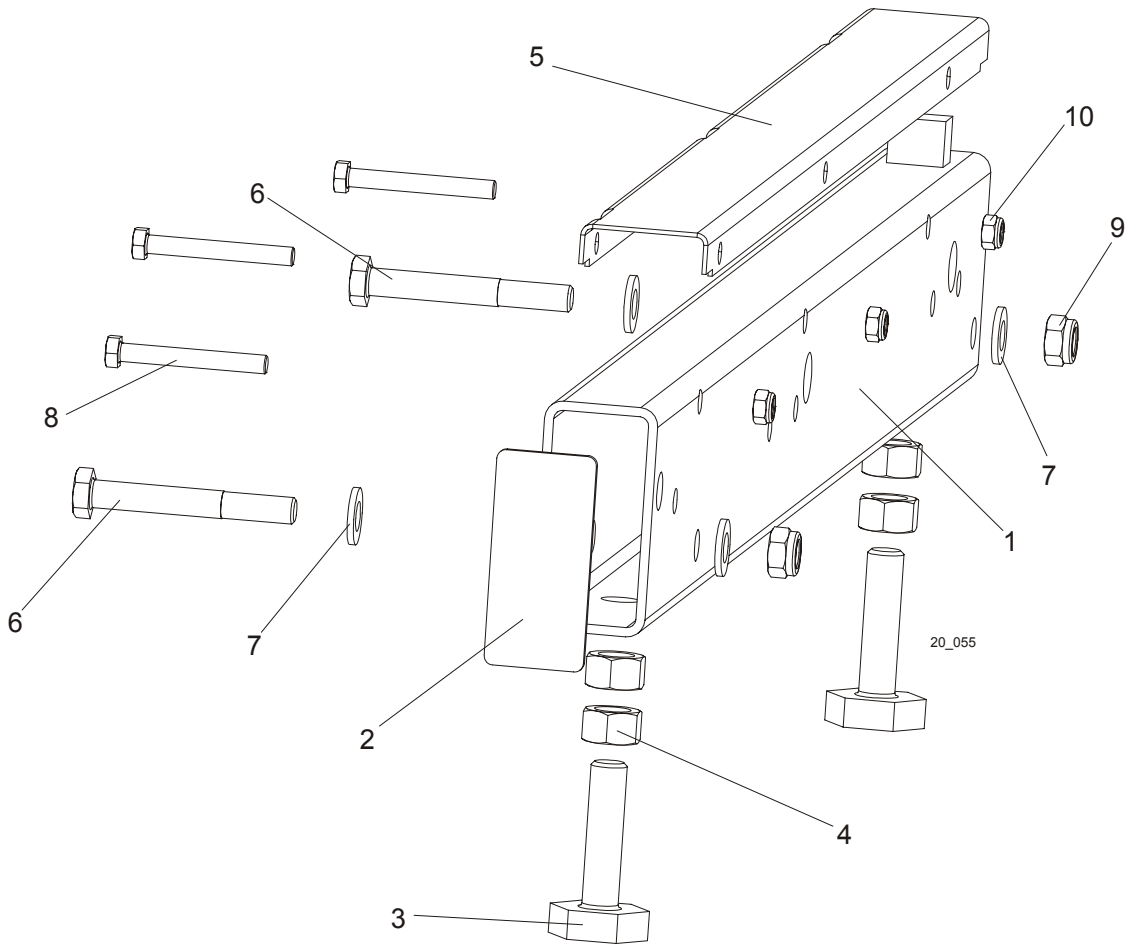

REF	DESCRIPTION (◆ Indicates Parts Available In Assemblies Only)	PART #	QTY.
	<b>LONG BED RAIL ASSEMBLY</b>	089385	1
1	Bed Rail Tube, Long	087433	1
2	Plate, Bed Rail End Cap	087853	1
3	Bolt, Bed Rail Adjustment	S13006	2
4	Nut, 5/8-11 Hex	F05010-54	4
5	Cover, Stainless Steel Bed Rail	099124	1
6	Bolt, M12 x 90-8.8 Hex Head Zinc	F81004-2	2
7	Washer, 13 Zinc Flat	F81056-1	4
8	<b>Bolt, M8x65-5.8 Hex Head Zinc</b>	F81002-3	3
9	Nut, M12-8 Hex Nylon Zinc Lock	F81034-2	2
10	Nut, M8-8-B Hex Nylon Zinc Lock	F81032-2	3

## 8.6 Bed Rail Assembly (L type frame)

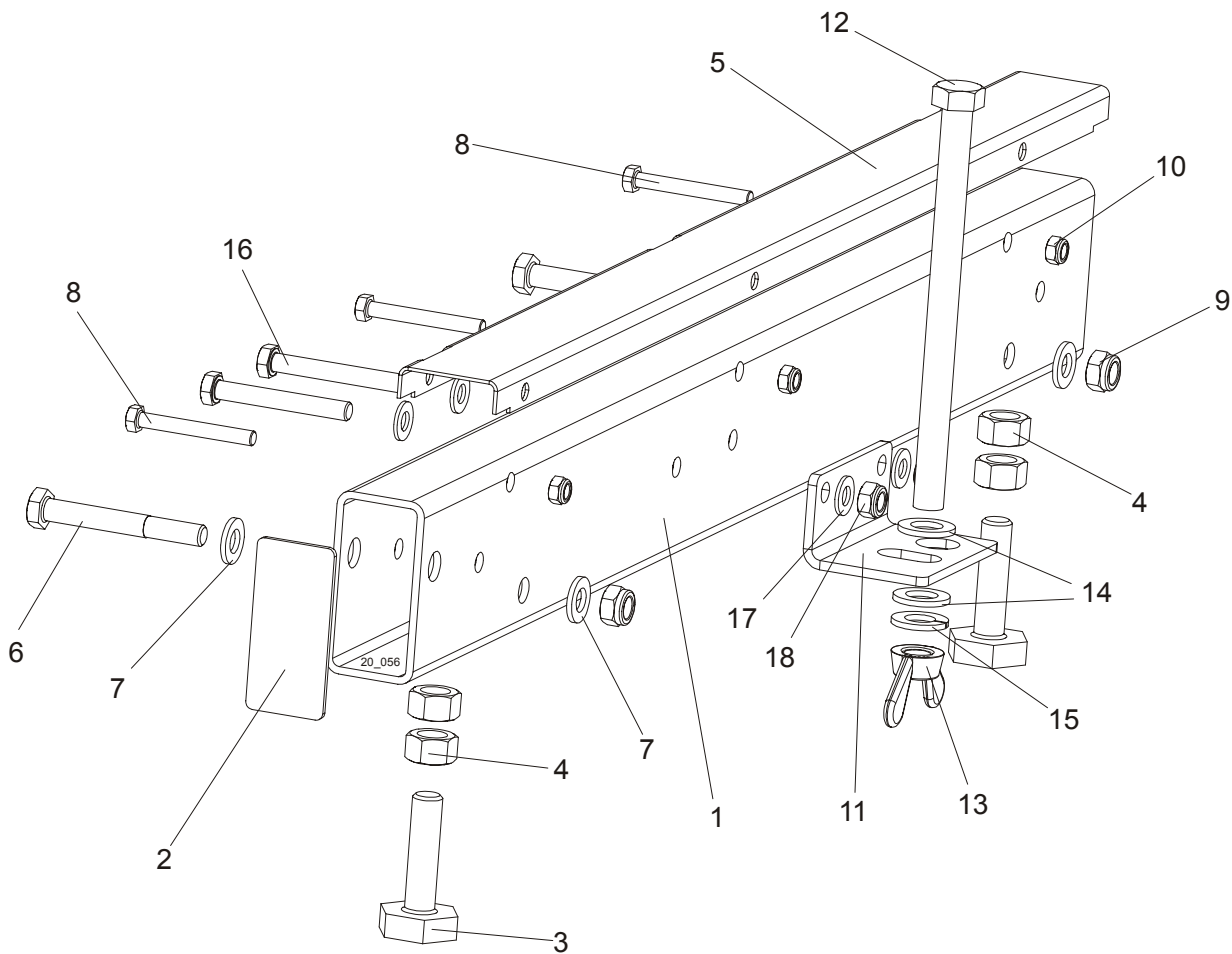

REF	DESCRIPTION (◆ Indicates Parts Available In Assemblies Only)	PART #	QTY.
	<b>BED RAIL ASSEMBLY, SHORT</b>	089386	1
1	Bed Rail Tube, Short	087878	1
2	Plate, Bed Rail End Cap	087853	1
3	Bolt, Bed Rail Adjustment	S13006	2
4	Nut, 5/8-11 Hex	F05010-54	4
5	Cover, Bed Rail Stainless Steel	099124	1
6	Bolt, M12x90-8.8 Hex Head Zinc	F81004-2	2
7	Washer, 13 Zinc Flat	F81056-1	4
8	<b>Bolt, M8x65-5.8 Hex Head Zinc</b>	F81002-3	3
9	Nut, M12-8 Hex Nylon Zinc Lock	F81034-2	2
10	Nut, M8-8-B Hex Nylon Zinc Lock	F81032-2	3
11	Bracket, Loading Arms Link Storage	090258-1	1
12	Bolt, M16x220-8.8-B Hex Head Zinc	F81006-21	1
13	Nut, M16-8 Hex Nylon Zinc Lock	F81036-2	1
14	Washer, 17 Zinc Flat	F81058-1	2
15	Washer, 16.3 Split Lock Zinc	F81058-2	1
16	Bolt, M10x75-8.8 Hex Head Zinc	F81003-15	2
17	<b>Washer, 10.5 Zinc Flat</b>	F81055-1	2
18	Nut, M10-8-B Hex Nylon Zinc Lock	F81033-1	2

8.7 Stationary Leg

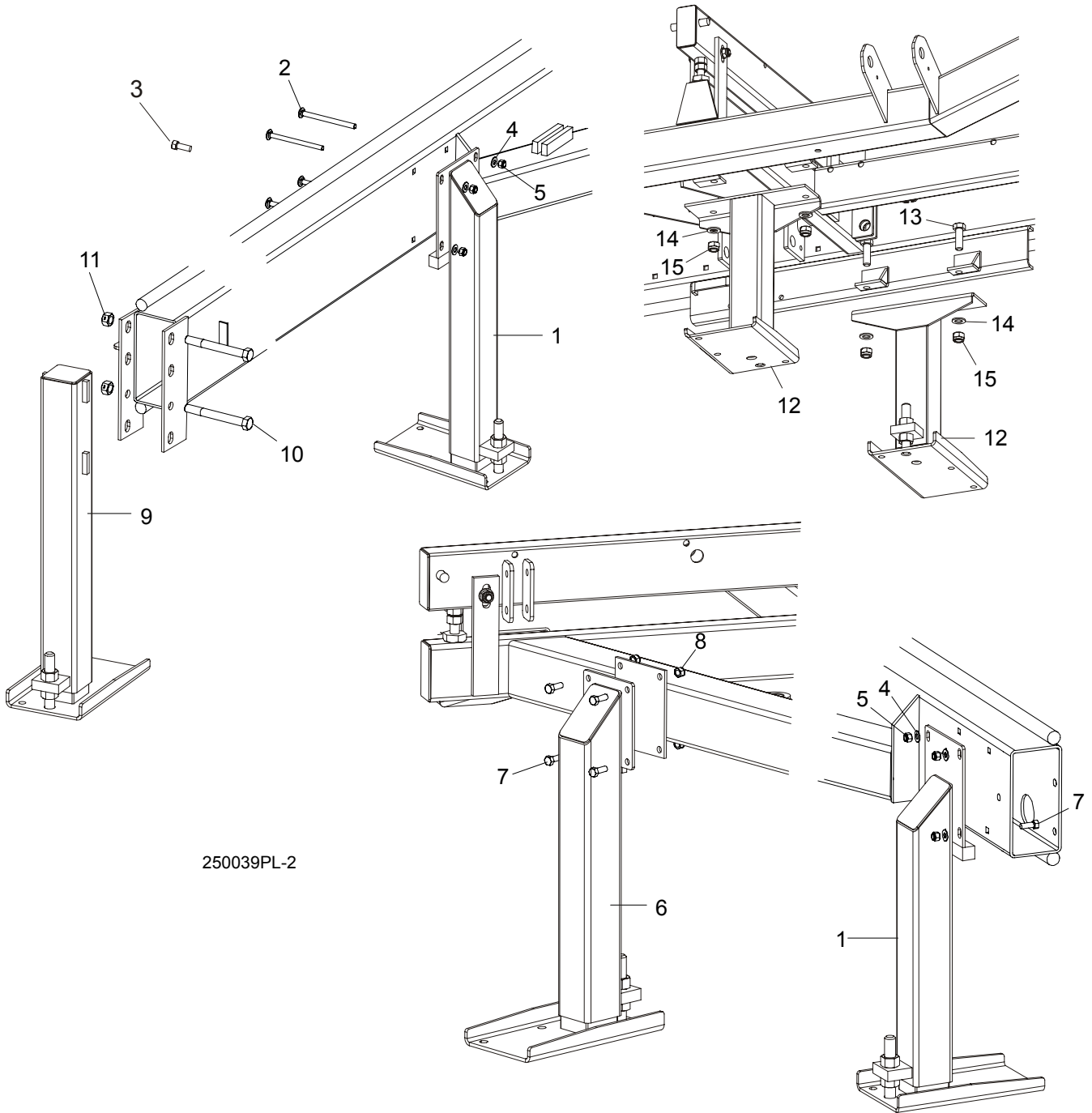

250039PL-2

REF	DESCRIPTION (◆ Indicates Parts Available In Assemblies Only)	PART #	QTY.
1	LEG, OUTRIGGER STATIONARY RIGHT	501640	2/3
2	BOLT, M10 X 120 - 8.8 CARRIAGE HEAD ZINC	F81003-33	8
3	BOLT, 3/8-16 X 1" HEX HEAD ZINC GRADE 8	F05007-7	4
4	WASHER, 10.5 ZINC FLAT	F81055-1	16
5	NUT, M10-8-B HEX NYLON ZINC LOCK	F81033-1	8/12
6	LEG, OUTRIGGER STATIONARY LEFT	501639	2
7	BOLT, M10 X 25-8.8 HEX HEAD ZINC	F81003-11	12

8	NUT, M10-8-B HEX NYLON ZINC LOCK	F81033-1	12	
9	LEG, OUTRIGGER STATIONARY FRONT	501641	1	
10	BOLT, M16 X 140 - 8.8 HEX HEAD	F81006-4	2	
11	NUT, 5/8-11 HEX ZINC	F05010-4	2	
12	LEG, OUTRIGGER STATIONARY MIDDLE	501637	2	
13	BOLT, M16 X 50-8.8 HEX HEAD FULL THREAD ZINC	F81006-7	4	
14	WASHER, 17 ZINC FLAT	F81058-1	4	
15	NUT, M16-8 HEX NYLON ZINC LOCK	F81036-2	4	

8.8 Pivot Bed Rail Assembly

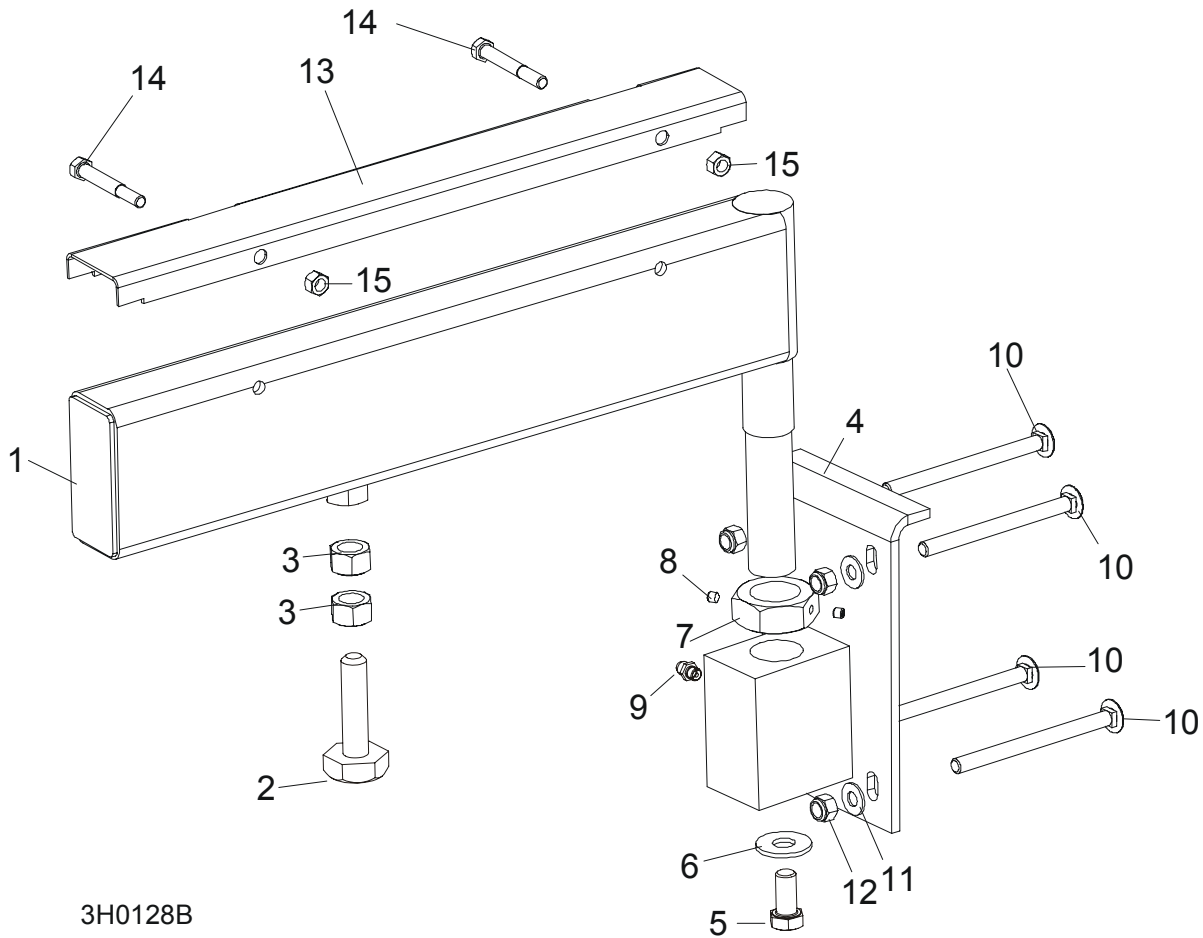

3H0128B

REF	DESCRIPTION (◆ Indicates Parts Available In Assemblies Only)	PART #	QTY.
	<b>PIVOT BED RAIL, COMPLETE</b>	087829	2
	<b>PIVOT BED RAIL, COMPLETE</b>	087855	2
1	Rail Weldment, Pivot Bed	087852-1	1
	Rail, Pivot Bed	087848-1	1
	Bolt Assembly, Bed Rail Adjustment		
2	Bolt, Pivot Bed Rail Adjustment	086809	1
3	Nut, M16-5.8 Zinc Hex	F81036-1	2
4	Bracket, Pivot Bed Rail Mounting	087841-1	1
5	Bolt, M12x25-8.8 Hex Head Full Thread Zinc	F81004-31	1
6	Washer, 9/16" Zinc Flat	F05011-52	1
7	Nut, M16-5.8 Zinc Hex Nut, M32 Zinc Hex Thin	F81036-1 F81039-2	1
8	Screw, 1/4-28 x 1/4 Socket Head Brass Tip Set	F05005-42	2
9	Fitting, M6 Grease	086280	1
10	<b>BOLT, M10 X 120 8.8 CARRIAGE HEAD ZINC</b>	F81003-33	2
11	<b>BOLT, M10 X 120 8.8 CARRIAGE HEAD ZINC</b>	F81003-33	6
12	<b>WASHER, 10.5 ZINC FLAT</b>	F81055-1	8
13	<b>NUT, M16-8 HEX NYLON ZINC LOCK</b>	F81036-2	8
	<b>COVER KIT, PIVOT BED RAIL</b>	015926	2
	<b>COVER KIT, PIVOT BED RAIL</b>	N/A	2



<b>14</b>	Cover, Pivot Bed Rail Stainless Steel	012994	1	
	Cover, Pivot Bed Rail	099123	1	
<b>15</b>	Bolt, M8x65-5.8 Hex Head Zinc	F81002-3	2	
<b>16</b>	Nut, M8-8-B Hex Nylon Zinc Lock	F81032-2	2	
	<b>WRENCH, BED RAIL ADJUSTMENT</b> ( <a href="#">Patrz rozdział 8.4</a> )	015970	1	

8.9 Board Return Table, Log Side Support Assembly

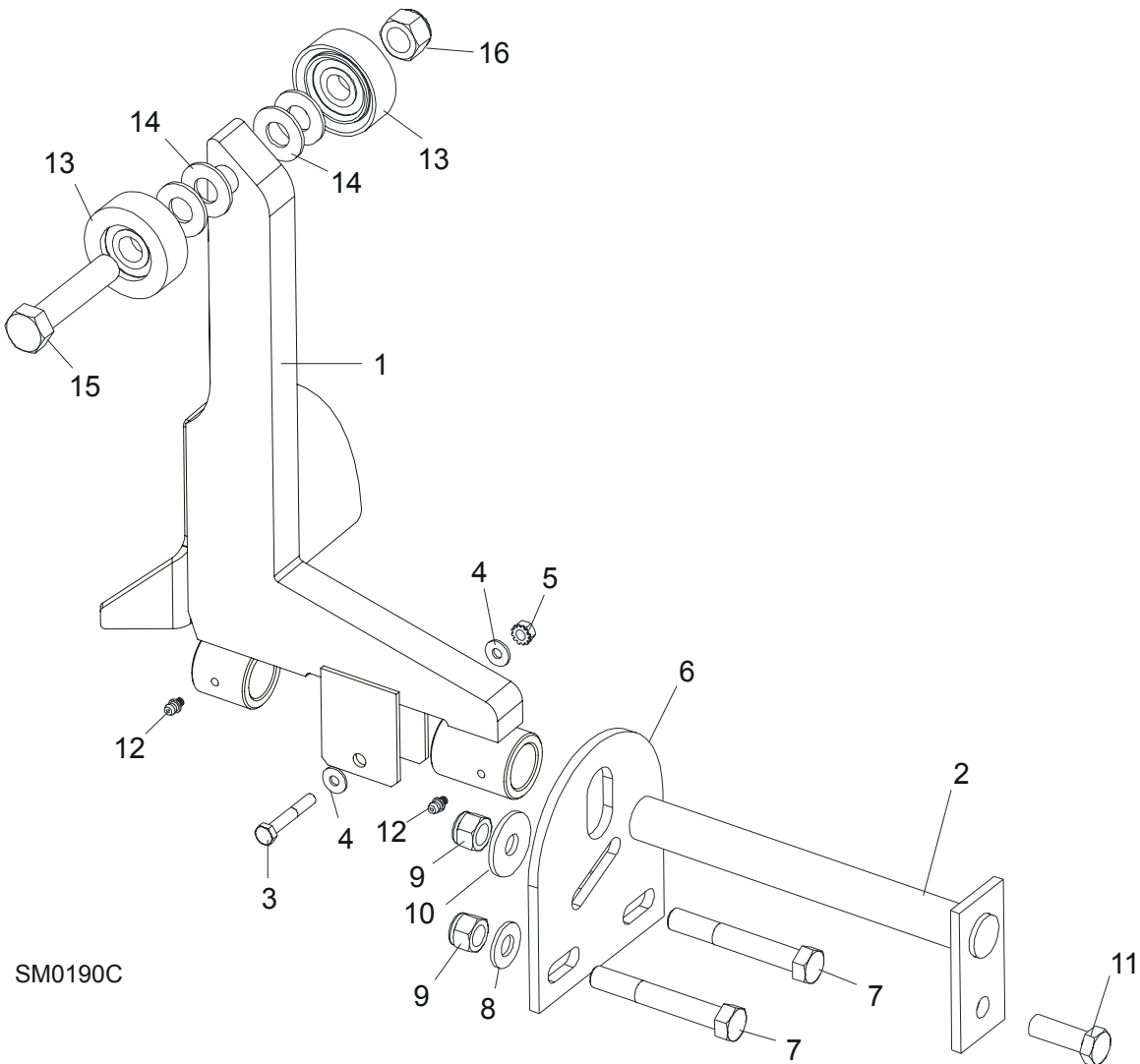

SM0190C

REF	DESCRIPTION (◆ Indicates Parts Available In Assemblies Only)	PART #	QTY.
1	SUPPORT, LOG SIDE W/GUARD	099785-1	1
2	PIN, LOG SIDE SUPPORT PIVOT	091549-1	1
3	BOLT, M8X45 - 8.8 HEX HEAD GRADE 5	F81002-14	1
4	WASHER, 8.4 FLAT	F81054-1	2
5	NUT, M8-8-B SELF LOCKING	F81032-2	1
6	PLATE, LOG SIDE SUPPORT END	091591-1	1
7	BOLT, M12 X 75-8.8 HEX HEAD	F81004-21	2
8	WASHER, 13 FLAT	F81056-1	2
9	NUT, M12-8 HEX NYLON LOCK	F81034-2	3
10	WASHER, 15 FLAT SPECIAL ZINC-PLATED	F81057-3	1
11	BOLT, M12 X 35-8.8 HEX HEAD	F81004-24	1
12	FITTING, 3/16" GREASE	P04107	2
13	ROLLER ASSEMBLY, SIDE SUPPORT	015014-1	2
14	WASHER, 17 FLAT	F81058-1	2
15	BOLT, M16X65-8.8-B HEX HEAD GRADE 5	F81006-1	1

<b>16</b>	<b>NUT, M16-8 NYLON LOCK</b>	F81036-2	1	
	<b>INSTRUCTION SHEET, SIDE SUPPORT ROLLER</b>	015109-526	1	

**8.10 Tie Down Chain Assembly**

SM0129

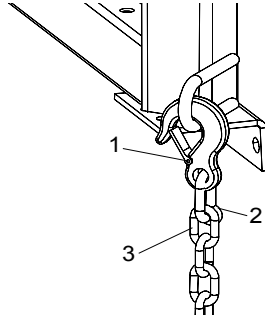

REF	DESCRIPTION (◆ Indicates Parts Available In Assemblies Only)	PART #	QTY.	
	<b>TIE DOWN CHAIN ASSEMBLY</b>	A04376-1	1	
1	Hook, 5/8" Safety Chain	P12075	1	◆
2	Screw Closed Chain Link, 10	100767	1	◆
3	Chain, N-10 x 35, 6 Links	100951	1	◆

## 8.11 Inspection Platform (DC mills only)

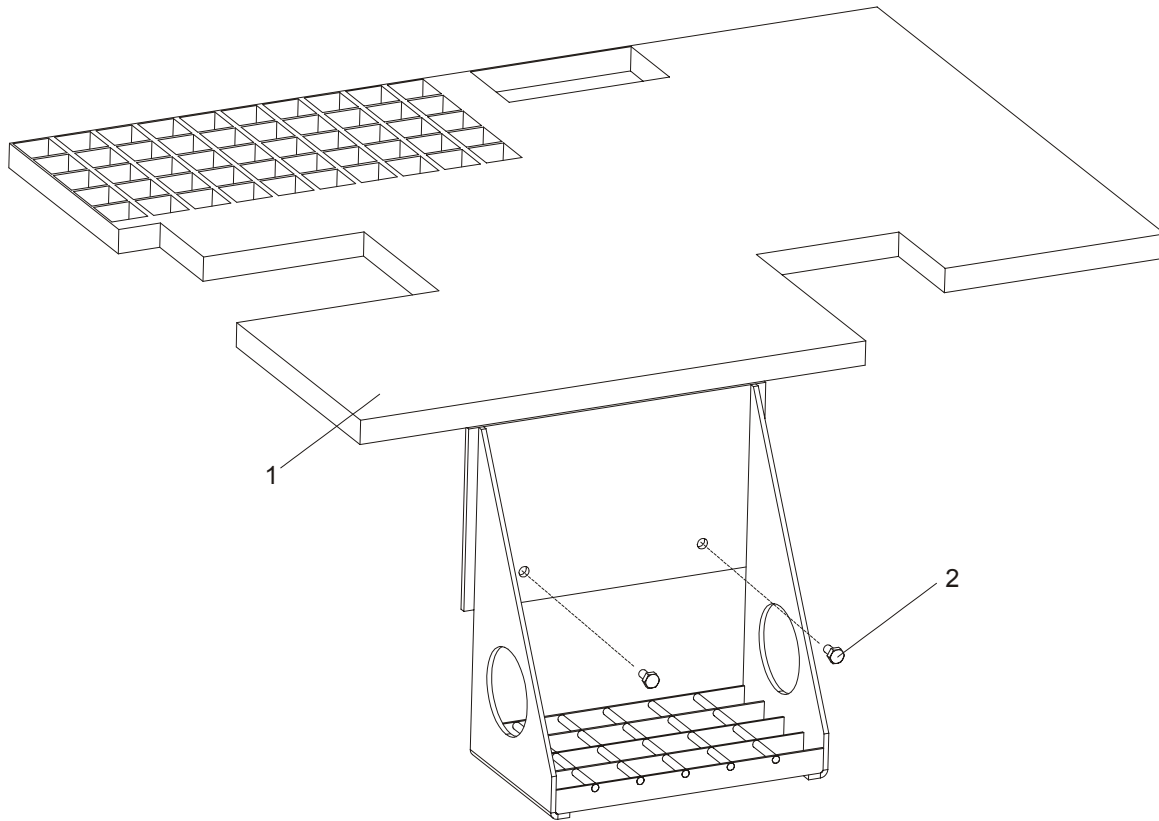

REF	DESCRIPTION (◆ Indicates Parts Available In Assemblies Only)	PART #	QTY.
	<b>PLATFORM, INSPECTION COMPLETE</b>	093062	1
<b>1</b>	PLATFORM, INSPECTION PTD	093061-1	1
<b>2</b>	BOLT, 1/4-20 X 1/2 HEX HEAD	F05005-15	2

**8.12 Bed Frame Decals**

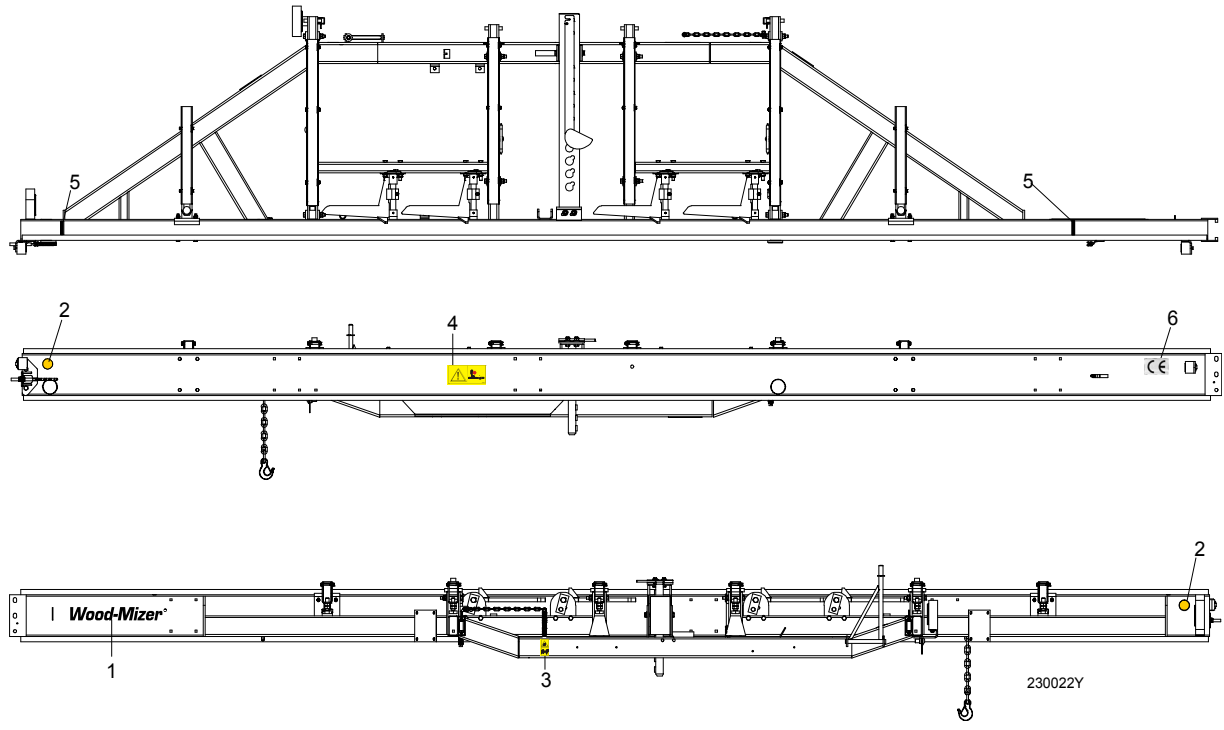

REF	DESCRIPTION (◆ Indicates Parts Available In Assemblies Only)	PART #	QTY.
1	DECAL, WOOD-MIZER LOGO	014751	1
2	DECAL, AMBER REFLECTIVE 2" ROUND	P07453	2
3	DECAL, KEEP AWAY DANGER, PICTOGRAM	099221	1
4	DECAL, SAWMILL TRAILER CAUTION, PICTOGRAM	099542	1
5	DECAL, LOG LENGTH LIMIT	S12051	2
6	DECAL, CE CERTIFIED SAWMILL SMALL	P85070	1

## SECTION 9 HYDRAULIC SYSTEM

### 9.1 Hydraulic Hoses, LT20 Series A/DH

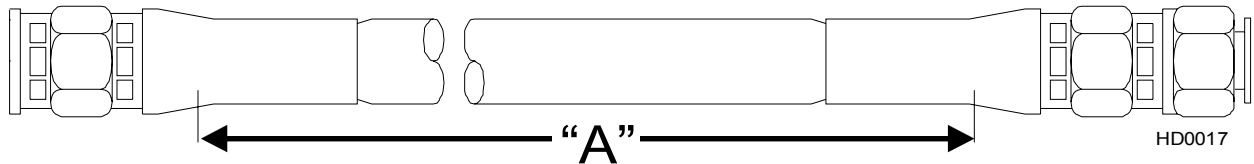

COLOR	LENGTH "A"	DESCRIPTION (◆ Indicates Parts Available In Assemblies Only)	PART #	QTY	ID
None	10"	3/8" HYDRAULIC PUMP TO VALVE	087774	1	H1
None	0,46	1/4" HYDRAULIC PUMP TO VALVE	015704	2	
Plain	27"	3/8" LOG TURNER CYLINDER BASE	014796	1	H3
Orange	22"	3/8" LOG TURNER CYLINDER TOP	087775	1	H4
Yellow	129"	1/4" FRONT TOE BOARD TOP (LT40S)	087790	1	H5
	151"	1/4" FRONT TOE BOARD TOP (LT40M)	087776	1	H5
Gray	129"	1/4" FRONT TOE BOARD BASE (LT40S)	087790	1	H6
	151"	1/4" FRONT TOE BOARD BASE (LT40M)	087776	1	H6
Plain	166"	3/8" SIDE SUPPORT CYLINDER TOP (LT40S)	087791	1	H7
	188"	3/8" SIDE SUPPORT CYLINDER TOP (LT40M)	087777	1	H7
Pink	168"	3/8" SIDE SUPPORT CYLINDER BASE (LT40S)	087791	1	H8
	188"	3/8" SIDE SUPPORT CYLINDER BASE (LT40M)	087777	1	H8
White	145"	3/8" CLAMP CYLINDER TOP (LT40S)	087792	1	H9
	157"	3/8" CLAMP CYLINDER TOP (LT40M)	087778	1	H9
Dark Orange	129"	3/8" CLAMP CYLINDER BASE (LT40S)	087793	1	H10
	151"	3/8" CLAMP CYLINDER BASE (LT40M)	087779	1	H10
Purple	204"	1/4" REAR TOE BOARD TOP (LT40S)	087794	1	H11
	226"	1/4" REAR TOE BOARD TOP (LT40M)	087780	1	H11
Black	204"	1/4" REAR TOE BOARD BASE (LT40S)	087794	1	H12
	226"	1/4" REAR TOE BOARD BASE (LT40M)	087780	1	H12
Green	62"	3/8" LOADING ARM BRANCH TOP	014797	2	H13
Yellow	63"	3/8" LOADING ARM BRANCH BASE	014798	1	H14
Yellow	71"	3/8" LOADING ARM BRANCH BASE	093329	1	H14
Blue	171"	3/8" LOADING ARM CYLINDER TOP (LT40S)	087795	1	H15
	193"	3/8" LOADING ARM CYLINDER TOP (LT40M)	087781	1	H15
Red	171"	3/8" LOADING ARM CYLINDER BOTTOM (LT40S)	087795	1	H16
	193"	3/8" LOADING ARM CYLINDER BOTTOM (LT40M)	087781	1	H16
Green	180"	1/4" CLAMP UP (LT40S)	087796	1	H17
	202"	1/4" CLAMP UP (LT40M)	087789	1	H17
Yellow	180"	1/4" CLAMP DOWN (LT40S)	087796	1	H18
	202"	1/4" CLAMP DOWN (LT40M)	087789	1	H18
White	157"	3/8" FRONT LOG CLAMP, IN/OUT CYLINDER BOTTOM (A/DH5)	094778	1	H19
Orange	157"	3/8" FRONT LOG CLAMP, IN/OUT CYLINDER TOP (A/DH5)	094778	1	H20

Red	150"	<b>3/8" FRONT LOG CLAMP, UP/DOWN CYLINDER BOTTOM (A/DH5)</b>	094779	1	H21
Blue	150"	<b>3/8" FRONT LOG CLAMP, UP/DOWN CYLINDER TOP (A/DH5)</b>	094779	1	H22
White	236"	<b>3/8" REAR LOG CLAMP, IN/OUT CYLINDER BOTTOM (A/DH5)</b>	094780	1	H23
Orange	236"	<b>3/8" REAR LOG CLAMP, IN/OUT CYLINDER TOP (A/DH5)</b>	094780	1	H24
Red	220"	<b>3/8" REAR LOG CLAMP, UP/DOWN CYLINDER BOTTOM (A/DH5)</b>	094781	1	H25
Blue	220"	<b>3/8" REAR LOG CLAMP, UP/DOWN CYLINDER TOP (A/DH5)</b>	094781	1	H26
Plain	15"	<b>3/8" VALVE TO OIL FLOW CONTROL VALVE (A/DH5)</b>	094782	1	H27
Plain	21"	<b>3/8" HYDRAULIC PUMP W/MOTOR TO OIL FLOW CONTROL VALVE (A/DH5)</b>	087775	1	H28
Red	1,50	<b>1/4" FIRST CLAMP, UP/DOWN CYLINDER BOTTOM (AH7)</b>	095211	1	H29
Blue	1,50	<b>1/4" FIRST CLAMP, UP/DOWN CYLINDER TOP (AH7)</b>	095211	1	H30
Red	4,00	<b>1/4" SECOND CLAMP, UP/DOWN CYLINDER BOTTOM (AH7)</b>	095212	1	H31
Blue	4,00	<b>1/4" SECOND CLAMP, UP/DOWN CYLINDER TOP (AH7)</b>	095212	1	H32
Red	7,70	<b>1/4" THIRD CLAMP, UP/DOWN CYLINDER BOTTOM (AH7)</b>	095213	1	H33
Blue	7,70	<b>1/4" THIRD CLAMP, UP/DOWN CYLINDER TOP (AH7)</b>	095213	1	H34
Orange	0,40	<b>1/4" HYDRAULIC VALVE POWER CORD TO CLAMP IN/OUT CYLINDER T-FITTING, BOTTOM (AH7)</b>	095214	1	H35
White	0,40	<b>1/4" HYDRAULIC VALVE POWER CORD TO CLAMP IN/OUT CYLINDER T-FITTING, TOP (AH7)</b>	095214	1	H36
Orange	7,00	<b>1/4" THIRD CLAMP, IN/OUT CYLINDER BOTTOM (AH7)</b>	095215	1	H37
White	7,00	<b>1/4" THIRD CLAMP, IN/OUT CYLINDER TOP (AH7)</b>	095215	1	H38
Orange	2,50	<b>1/4" FIRST/SECOND CLAMP, IN/OUT CYLINDER BOTTOM (AH7)</b>	095216	1	H39
White	2,50	<b>1/4" FIRST/SECOND CLAMP, IN/OUT CYLINDER TOP (AH7)</b>	095216	1	H40
Orange	1,20	<b>1/4" FIRST/SECOND CLAMP, IN/OUT CYLINDER BOTTOM (AH7)</b>	095217	1	H41
White	1,20	<b>1/4" FIRST/SECOND CLAMP, IN/OUT CYLINDER TOP (AH7)</b>	095217	1	H42



## 9.2 Hydraulic Hoses, LT20 Series DH

[See Section 1.18](#) of the LT20 DH Operators Manual (Form#629)

### *Protective Conduits, LT20 Series A/DH Hydraulic Hoses*

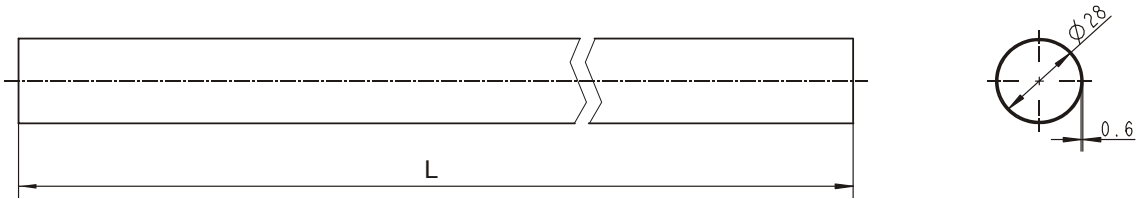

LENGTH "L"	DESCRIPTION (◆ Indicates Parts Available In Assemblies Only)	PART #	QTY.	
0,70	PROTECTIVE CONDUIT, LOG TURNER HOSE	099761	2	
0,28	PROTECTIVE CONDUIT, IN/OUT CYLINDER HOSE - BOTTOM	099762	1	
0,45	PROTECTIVE CONDUIT, IN/OUT CYLINDER HOSE - TOP	099763	1	
1,35	PROTECTIVE CONDUIT, UP/DOWN CYLINDER HOSE - BOTTOM	099764	1	
1,65	PROTECTIVE CONDUIT, UP/DOWN CYLINDER HOSE - TOP	099765	1	

9.3 Hydraulic Control Box, LT20 Series AH3

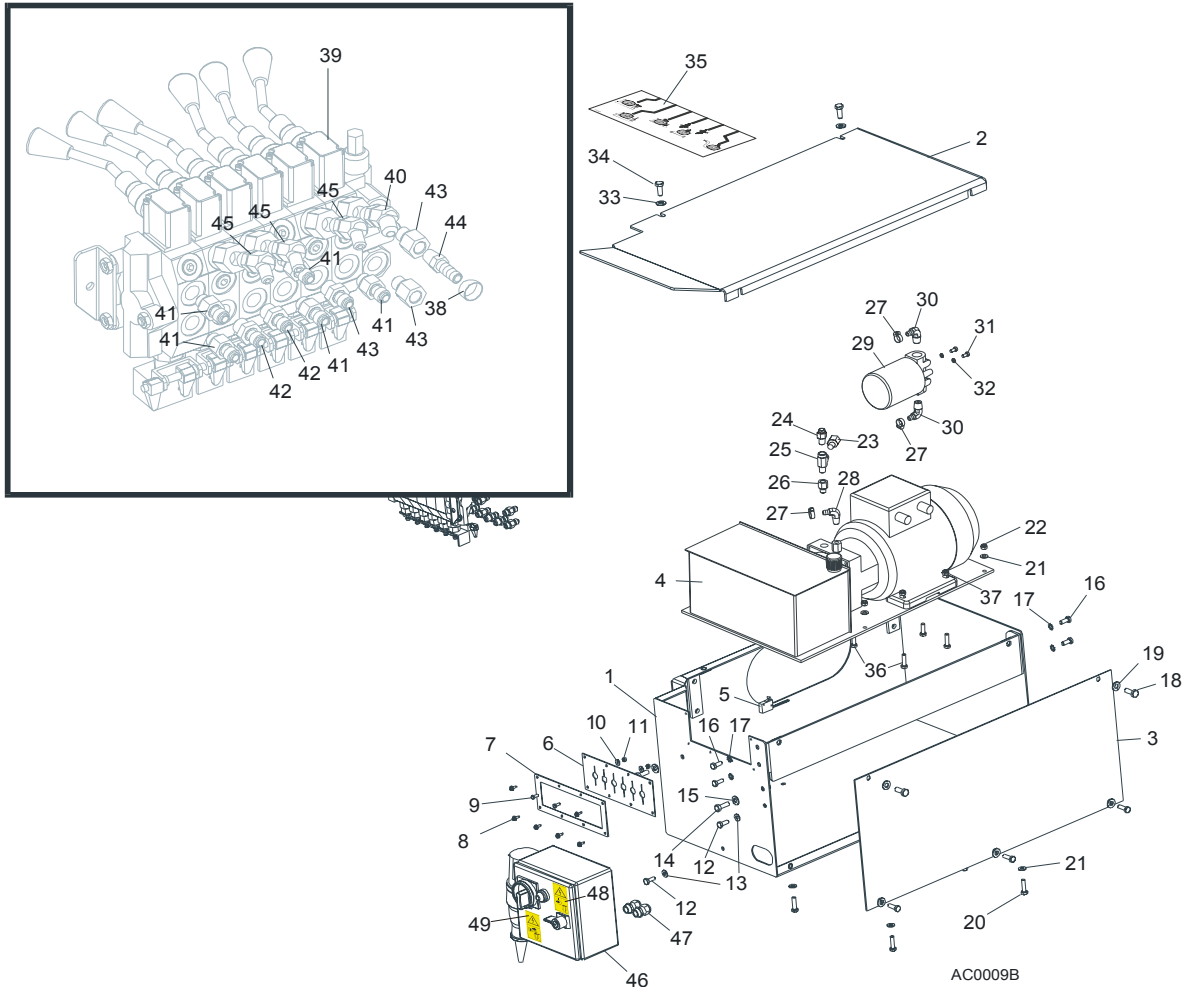

REF	DESCRIPTION (◆ Indicates Parts Available In Assemblies Only)	PART #	QTY.
	<b>BOX, AC SUPER HYDRAULIC (EA20, EA25)</b>	086791	1
	Cap, SR1086 22.2 Hole	093544	2
1	<b>BOX WELDMENT, HYDRAULIC PUMP HOUSING</b>	092243-1	1
2	<b>COVER, AC HYDRAULIC PUMP HOUSING TOP</b>	086485-1	1
3	<b>COVER, AC HYDRAULIC PUMP HOUSING SIDE</b>	086484-1	1
4	<b>HYDRAULIC PUMP W/MOTOR, 4 KW 14.5 L/MIN AC</b>	093459	1
	Pump, AC-4kW Hydraulic	097782	1
	Plate, AC-4kW Hydraulic Connecting	097783	1
	Seal, AC-4kW Hydraulic Complete	097784	1
5	Microswitch, 2A 125V Hydraulic Valve	014765	1
6	<b>GUARD, DOUBLE VALVE RUBBER</b>	015079	1
7	<b>PLATE, AC VALVE PAINTED</b>	086519-1	1
8	<b>SCREW, #10 X 1/2 SLOTTED HEX SELF-TAPPING</b>	F05015-7	6
9	<b>BOLT, M5X12-5.8 HEX HEAD FULL THREAD ZINC</b>	F81000-5	2
10	<b>WASHER, 5.5 SPECIAL FLAT ZINC</b>	F81052-3	2

11	NUT, M5-8 HEX ZINC	F81030-1	2	
12	BOLT, M8 X 20-8.8-B HEX HEAD FULL THREAD ZINC	F81002-4	2	
13	WASHER, 8.4 FLAT ZINC	F81054-1	2	
14	BOLT, 3/8-16X1 HEX HEAD ZINC GRADE 8	F05007-7	2	
15	WASHER, 10.5 FLAT ZINC	F81055-1	2	
16	BOLT, M8 X 20-8.8-B HEX HEAD FULL THREAD ZINC	F81002-4	4	
17	WASHER, 8.4 EXTERNAL STAR LOCK	F81054-3	4	
18	BOLT, M10 X 25-8.8 HEX HEAD FULL THREAD ZINC	F81003-11	4	
19	WASHER, 10.5 FLAT ZINC	F81055-1	4	
20	BOLT, M8 X 25-8.8-B HEX HEAD FULL THREAD ZINC	F81002-5	4	
21	WASHER, 8.4 FLAT ZINC	F81054-1	4	
22	NUT, M8-8-B HEX NYLON ZINC LOCK	F81032-2	4	
23	PLUG, 1/4" NPT EXTERNAL THREAD	096221	1	
24	FITTING, 1/4NPT X 1/4JIC MALE	P09143	1	
25	FITTING, 1/4NPT X 1/4JIC MALE RUN TEE	P09141	1	
26	FITTING, 6SAE MALE - 1/4NPT FEMALE	014686	1	
27	CLAMP, 11/16 HOSE	P12739	3	
28	FITTING, 3/8" NPT - 3/8" BARB ELBOW	P12708	1	
29	MANIFOLD, 1.2" W/FILTER	P22683	1	
30	FITTING, 1/2" NPT - 3/8" BARB ELBOW	P12707	2	
31	BOLT, 1/4-20 X 1/2" HEX HEAD ZINC GRADE 2	F05005-15	2	
32	WASHER, 6.1 SPLIT LOCK ZINC	F81053-3	2	
33	WASHER, 10.5 FLAT ZINC	F81055-1	2	
34	BOLT, M10 X 25-8.8 HEX HEAD FULL THREAD ZINC	F81003-11	2	
35	DECAL, 1997 SUPER HYDRAULIC CONTROL BOX	015364	1	
36	BOLT, M8 X 30-8.8-B HEX HEAD FULL THREAD ZINC	F81002-7	4	
37	NUT, M8-8-B HEX NYLON ZINC LOCK	F81032-2	4	
38	CLAMP, 11/16" HOSE	P12739	10	
39	VALVE, HYDRAULIC 6-SECTION	086589	1	
	MICROSWITCH ASSEMBLY, HYDRAULIC VALVE	024198	1	
40	FITTING, #6 SAE 45° ELBOW	015489	1	
41	FITTING, 3/8" O-RING - 3/8" JIC	014687	5	
42	FITTING, 3/8" O-RING - 1/4" JIC	P26284	3	
43	FITTING, #6 SAE MALE - 1/4" NPT FEMALE	014686	2	
44	FITTING, 1/4" NPT X 3/8" HOSE BARB	014685	1	
45	FITTING, #6 SAE - 1/4" JIC 45° ELBOW	015488	3	
46	BOX, ELECTRIC HYDRAULIC LT20 <i>(See Section 1.20 Electrical Information, 620 Operation Manual)</i>	093088	1	
	Contactor, LC1 K0910 P7	092736	1	
	Light, XB4-BVM1 White	084310	1	
	Phase Supply Control Relay, RM3 TG201	084452	1	
	Time Relay, 72.31.8.400.0000	501016	1	
	Switch, RELPOL MT-TUA-17S-11-92	501015	1	
	Thermal Overload Relay, LR2 K0316	084456	1	
	Switch, AAB OT16E3	089801	1	
	Plyg,16A 5P 2607 BALS	E85239	1	
	Switch, 2A 125V R-LEVER NO/NC/COM	014765	1	

## 9

**Hydraulic System***Hydraulic Control Box, LT20 Series AH3*

---

	Limit Switch, GLCB01A1B	100931	1	
47	<b>GLAND, DP 11/H CABLE (SUPER ONLY)</b>	085388	2	
48	<b>DECAL, HIGH VOLTAGE INSIDE THE ELECTRIC BOX (PICTOGRAM)</b>	096316	1	
49	<b>DECAL, REMOVE THE PLUG BEFORE OPENING THE BOX (PICTOGRAM)</b>	096319	1	

9.4 Hydraulic Control Box, LT20 Series AH5/7

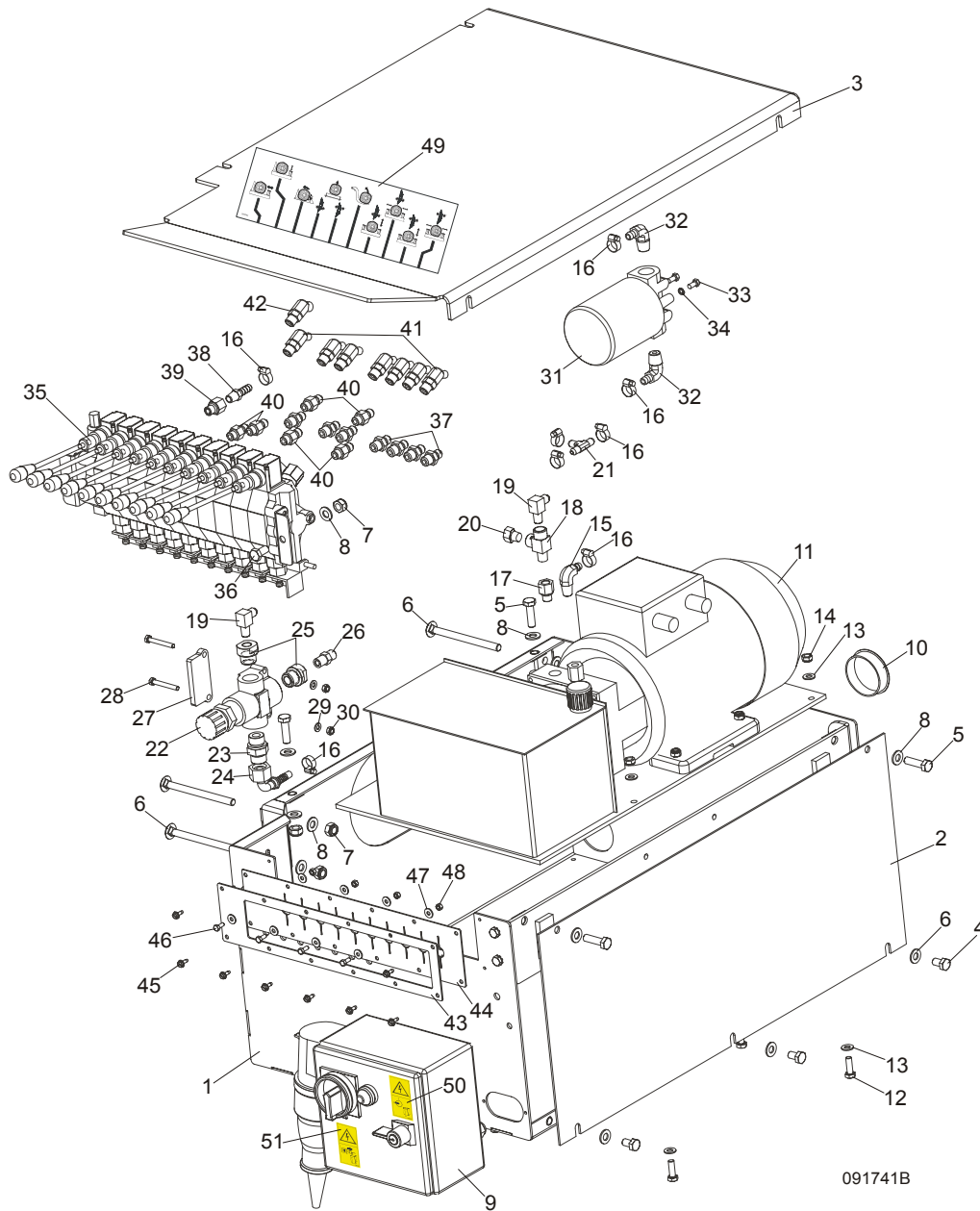

REF	DESCRIPTION (◆ Indicates Parts Available In Assemblies Only)	PART #	QTY.
	<b>BOX ASSEMBLY, LT20 AH5 HYDRAULIC CONTROL</b>	093128	1
1	Box Weldment, Hydraulic Pump Housing	091729-1	1
	Bracket, AC Hydraulic Control Box Complete	086518-1	1
	Bolt, M8x20-8.8-B Hex Head Full Thread Zinc	F81002-4	4
	Washer, 8.4 External Star	F81054-3	4
2	Cover, AC Hydraulic Pump Housing Side	086484-1	1
3	Cover, AC/DC Hydraulic Pump Housing Top	091734-1	1
4	Bolt, M10x16-8.8 Hex Head Full Thread Zinc	F81003-13	3

5	Bolt, M10x35-8.8 Hex Head Full Thread Zinc	F81003-17	4	
6	Bolt, M10x125 8.8 Carriage Head Zinc	F81003-34	4	
7	Nut, M10-8-B Hex Nylon Zinc Lock	F81033-1	6	
8	Washer, 10.5 Flat Zinc	F81055-1	13	
9	Box, Electric Hydraulic LT20 <i>(See Section 1.20 Electrical Information, 620 Operation Manual)</i>	093088	1	
	Contactor, LC1 K0910 P7	092736	1	
	Light, XB4-BVM1 White	084310	1	
	Phase Supply Control Relay, RM3 TG201	084452	1	
	Time Relay, 72.31.8.400.0000	501016	1	
	Switch, RELPOL MT-TUA-17S-11-92	501015	1	
	Thermal Overload Relay, LR2 K0316	084456	1	
	Switch, AAB OT16E3	089801	1	
	Plyg, 16A 5P 2607 BALS	E85239	1	
	Switch, 2A 125V R-LEVER NO/NC/COM	014765	1	
	Limit Switch, GLCB01A1B	100931	1	
10	Cap, HSA2790 (63.6 Dia.)	092859	1	
11	Hydraulic Pump W/Motor, 4 kW 14.5 l/min AC	093459	1	
	Pump, AC-4kW Hydraulic	097782	1	
	Plate, AC-4kW Hydraulic Connecting	097783	1	
	Seal, AC-4kW Hydraulic Complete	097784	1	
12	Bolt, M8 x 25-8.8-B Hex Head Full Thread Zinc	F81002-5	4	
13	Washer, 8.4 Flat Zinc	F81054-1	8	
14	Nut, M8-8-B Hex Nylon Zinc Lock	F81032-2	4	
15	Fitting, 3/8" NPT - 3/8" Barb Elbow	P12708	1	
16	Clamp, 11/16 Hose	P12739	8	
17	Fitting, 6 SAE Male - 1/4 NPT Female	014686	1	
18	Fitting, 1/4 NPT x 1/4 JIC Male Run Tee	P09141	1	
19	Fitting, 3/8 JIC - 1/4 NPT 90L	015491	2	
20	Plug, 1/4" NPT Blank	096221	1	
21	Fitting, 3/8" Barb Tee	015485	1	
22	Valve, MTKA.VB Oil Flow Control	093794	1	
23	Fitting, VMNW10HS22	094486	1	
24	Fitting, PN10AOL13-90 Elbow	094485	1	
25	Fitting, M22x1.5 / 1/4 - 18 NPT Zinc	093139-1	2	
26	Fitting, 3/8JIC-1/4 NPT Straight	015560	1	
27	Plate, MTKA Control Valve Spacer Zinc-Plated	094477-1	1	
28	Bolt, M6x45-8.8 Hex Head Zinc	F81001-6	2	
29	Washer, 6.4 Flat Zinc	F81053-1	2	
30	Nut, M6-8-B Hex Nylon Zinc Lock	F81031-2	2	
31	Manifold, 1.2" W/Filter	P22683	1	
32	Fitting, 1/2" NPT - 3/8" Barb Elbow	P12707	2	
33	Bolt, 1/4-20 x 1/2" Hex Head Zinc Grade 2	F05005-15	2	
34	Washer, Z6.1 Split Lock Zinc	F81053-3	2	
35	Valve, HDS11/10 6-Section Hydraulic	091344	1	
36	Bolt, M10x20-5.8 Hex Head Full Thread Zinc	F81003-1	2	
37	Fitting, 3/8" O-Ring - 1/4" JIC	P26284	7	

38	Fitting, 1/4" NPT x 3/8" Hose Barb	014685	1	
39	Fitting, #6 SAE Male - 1/4" NPT Female	014686	1	
40	Fitting, 3/8" O-Ring - 3/8" JIC	014687	6	
41	Fitting, #4 SAE - #6 SAE 45° Elbow	015488	7	
42	Fitting, #6 SAE 45° Elbow	015489	1	
43	Plate, 10-Section Valve Painted	091826-1	1	
44	Guard, 10-Section Valve Rubber	091739	1	
45	Screw, #10-24x1/2 Self-Tapping	F05015-7	8	
46	Bolt, M5x12-5.8 Hex Head Full Thread Zinc	F81000-5	4	
47	Washer, 5.5 Special Flat Zinc-Plated	F81052-3	8	
48	Nut, M5-8 Hex Zinc	F81030-1	4	
49	Decal, AH5 Hydraulic Control Box	094795	1	
	Decal, AH7 Hydraulic Control Box	094970	1	
50	<b>DECAL, HIGH VOLTAGE INSIDE THE ELECTRIC BOX (PICTOGRAM)</b>	096316	1	
51	<b>DECAL, REMOVE THE PLUG BEFORE OPENING THE BOX (PICTOGRAM)</b>	096319	1	

9.5 Hydraulic Control Box, LT20 Series DH3

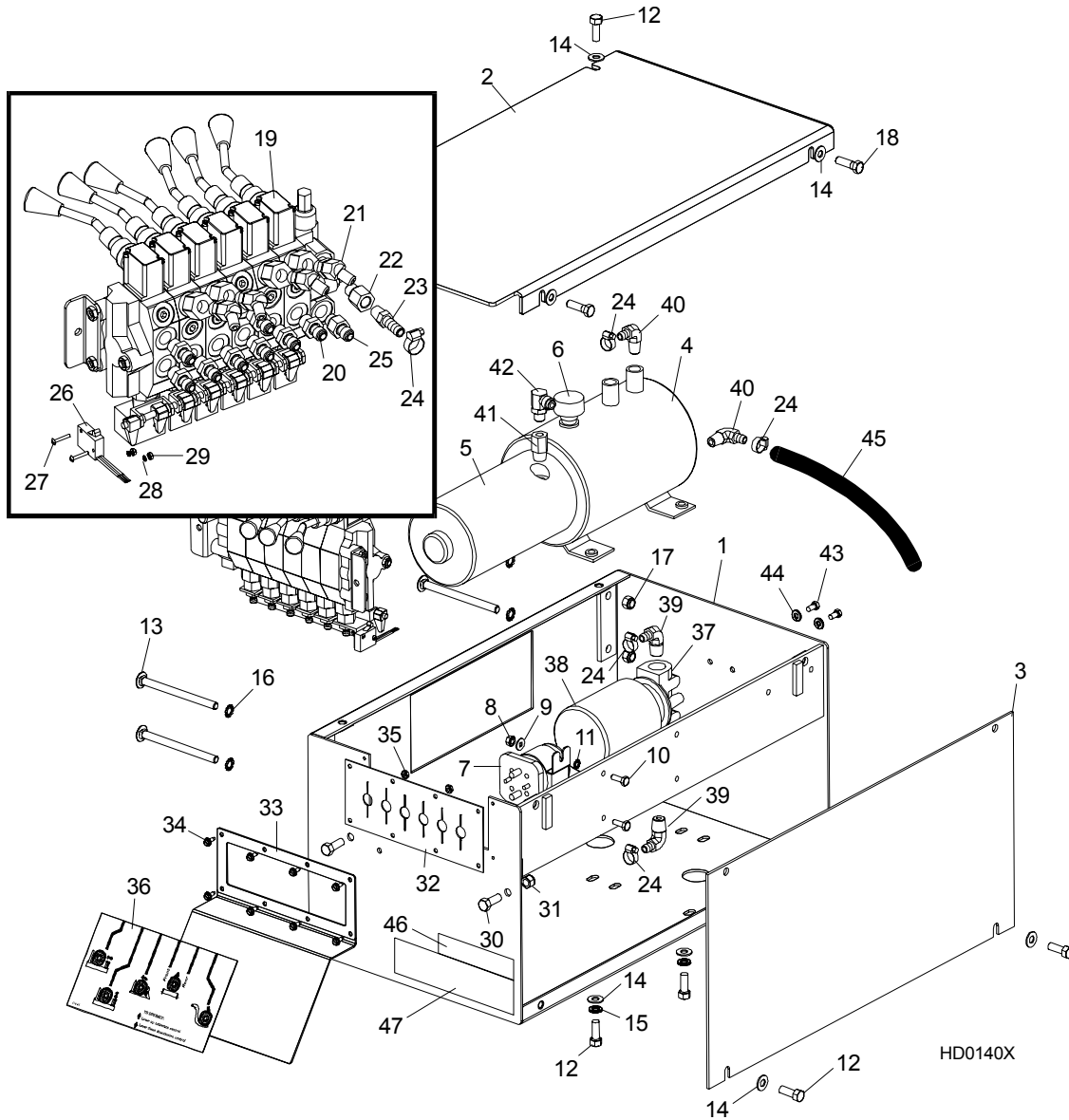

REF	DESCRIPTION (◆ Indicates Parts Available In Assemblies Only)	PART #	QTY.
1	BOX WELDMENT, SUPER HYDRAULIC PUMP HOUSING	092243-1	1
2	COVER, SUPER HYDRAULIC PUMP HOUSING TOP	086485-1	1
3	COVER, SUPER HYDRAULIC PUMP HOUSING SIDE	086484-1	1
4	PUMP W/MOTOR, HYDRAULIC #M-300-0230	P12701	1
5	Motor, 12 VDC Hydraulic Pump #08058	P09955	1
	Brush Kit, 4-Valve Hydraulic Pump Motor #08658	P09585	1
	Bearing, Base Motor #02318	P12513	1
6	Cap, Hydraulic Pump Vented Fill #03171	P12817	1



	O-Ring, Hydraulic Pump/Reservoir #02352	P10198	1	
	Seal, Hydraulic Pump/Motor #02330	P10315	1	
7	<b>SOLENOID, 200A 12V SPST HYDRAULIC PUMP MOTOR</b>	015470	1	
8	<b>NUT, 1/4-20 SELF-LOCKING HEX</b>	F05010-9	2	
9	<b>WASHER, 1/4" SAE FLAT</b>	F05011-11	2	
10	<b>BOLT, #1/4-20 X 3/4" HEX HEAD FULL THREAD</b>	F05005-1	2	
11	<b>WASHER, 1/4" EXTERIOR STAR LOCK</b>	F05011-37	2	
	<b>FLUID, 1-QUART DEXRON III HYDRAULIC</b>	P12742	8.5 l	
	<b>FLUID, 1-GALLON EXXON UNIVIS J26 HYDRAULIC</b>	P12823	8.5 l	
	<b>FLUID, 1-GALLON EXXON UNIVIS P13 HYDRAULIC</b>	P12822	8.5 l	
12	<b>BOLT, 3/8-16 X 1" HEX HEAD GRADE 8</b>	F05007-7	8	
13	<b>BOLT, 3/8-16 X 5" CARRIAGE HEAD</b>	F05007-113	4	
14	<b>WASHER, 3/8" SAE FLAT</b>	F05011-3	10	
15	<b>WASHER, 3/8" SPLIT LOCK</b>	F05011-4	4	
16	<b>WASHER, 3/8" EXTERNAL STAR LOCK</b>	F05011-36	4	
17	<b>NUT, 3/8-16 HEX NYLON LOCK</b>	F05010-10	4	
18	<b>BOLT, 3/8-16 X 1 1/4" HEX HEAD</b>	F05007-2	2	
19	<b>VALVE, HYDRAULIC 6 SECTION (<a href="#">See Form 575</a> FOR VALVE SERVICE PARTS)</b>	015260	1	
20	<b>FITTING, 3/8" O-RING - 1/4" JIC</b>	P26284	8	
21	<b>FITTING, #6 SAE - 1/4" JIC 45° ELBOW</b>	015488	4	
22	<b>FITTING, #6 SAE MALE - 1/4" NPT FEMALE</b>	014686	1	
23	<b>FITTING, 1/4" NPT X 3/8" HOSE BARB</b>	014685	1	
24	<b>CLAMP, 11/16" WORM</b>	P12739	5	
25	<b>FITTING, 3/8" O-RING - 1/4" JIC</b>	P26284	1	
26	<b>SWITCH, HYDRAULIC VALVE ELECTRIC</b>	024198	1	
27	<b>SCREW, #4-40 X 3/4" SLOTTED</b>	F05004-13	2	
28	<b>WASHER, #4 SPLIT LOCK</b>	F05011-21	2	
29	<b>NUT, #4-40 HEX</b>	F05010-43	2	
30	<b>BOLT, 3/8-16 X 1" HEX HEAD GRADE 8</b>	F05007-7	2	
31	<b>NUT, 3/8-16 HEX NYLON LOCK</b>	F05010-10	2	
32	<b>SEAL, RUBBER VALVE HANDLE</b>	015079	1	
33	<b>PLATE, VALVE HANDLE DECAL</b>	086519-1	1	
34	<b>SCREW, #10-24 X 1/2 SELF-TAPPING</b>	F05015-7	8	
35	<b>NUT, #10-24 SELF-LOCKING HEX</b>	F05010-14	2	
36	<b>DECAL, 1997 HYDRAULIC CONTROL BOX</b>	015364	1	
37	<b>MANIFOLD, HYDRAULIC CARTRIDGE FILTER</b>	P22683	1	
38	Filter, S28 Hydraulic Cartridge	P20301	1	
39	<b>FITTING, #6-8 (1/2" NPT) - 3/8" HOSE BARB ELBOW</b>	P12707	2	
40	<b>FITTING, #6-6 (3/8" NPT) - 3/8" HOSE BARB ELBOW</b>	P12708	2	
41	<b>FITTING, 3/8" NPT MALE - 1/4" NPT FEMALE</b>	015490	1	
42	<b>FITTING, 1/4" NPT - 1/4" JIC ELBOW</b>	P09142	1	
43	<b>BOLT, 1/4-20 X 1/2" HEX HEAD</b>	F05005-15	2	
44	<b>WASHER, 1/4" SPLIT LOCK</b>	F05011-14	2	
45	<b>HOSE, 3/8" LOW PRESSURE HYDRAULIC</b>	R01892-1	A/R	
	<b>GROUNDING ASSEMBLY, HYDRAULIC PUMP</b>	N/A	1	
	Bolt, 3/8-16 x 1/2" Hex Head Grade 5	F05004-124	1	

	Cable, 1AWG SO Welding	R01971	.39 m	
	Terminal, 5/16 1-2Ga Ring NI Loose	F05092-16	2	
	Washer, 3/8" Star External	F05011-36	2	
<b>46</b>	<b>DECAL, HYDRAULIC WORKING PRESSURE</b>	P85069	1	
<b>47</b>	<b>DECAL, HYDRAULIC FLUID</b>	P85068	1	

9.6 Hydraulic Control Box, LT20 Series DH5/7

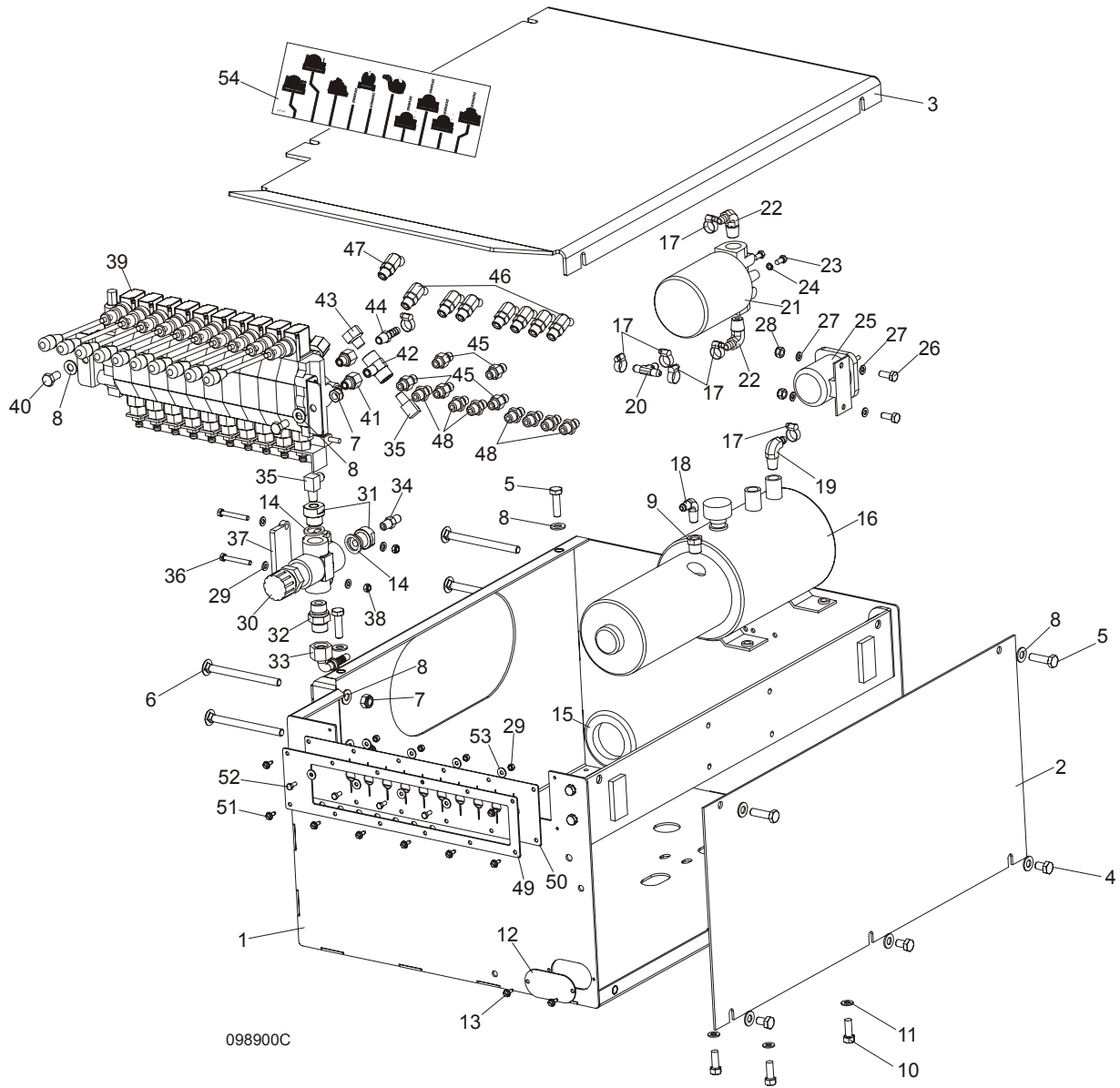

098900C

REF	DESCRIPTION (◆ Indicates Parts Available In Assemblies Only)	PART #	QTY.
	<b>BOX ASSEMBLY, LT20 DH5/7 HYDRAULIC CONTROL</b>	098900	1
1	Box Weldment, Hydraulic Pump Housing	091729-1	1
	Bracket, AC Hydraulic Control Box Complete	086518-1	1
	Bolt, M8X20-8.8-B, Hex Head Full Thread Zinc	F81002-4	4
	Washer, 8.4 External Star	F81054-3	4
2	Cover, AC Hydraulic Pump Housing Side	086484-1	1
3	Cover, AC/DC Hydraulic Pump Housing Top	091734-1	1
4	Bolt, M10x16-8.8 Hex Head Full Thread Zinc	F81003-13	3
5	Bolt, M10x35-8.8 Hex Head Full Thread Zinc	F81003-17	4
6	Bolt, M10x125 8.8 Carriage Head Zinc	F81003-34	4

7	Nut, M10-8-B Hex Nylon Zinc Lock	F81033-1	6	
8	Washer, 10.5 Flat Zinc	F81055-1	13	
9	Fitting, 3/8NPT-1/4NPT Reducer	015490	1	
10	Bolt, 3/8-16x1 Hex Head Grade 8	F05007-7	8	
11	Washer, 8.4 Flat Zinc	F81054-1	8	
12	Cap, Hydraulic Control Box	091733-1	1	
13	Screw, #10-24x1/2, Self Tap	F05015-7	2	
14	Washer, 22 Copper	F81061-5	2	
15	Grommet, 55mm Dia. Rubber	085614	1	
16	Pump Assy, W/Motor Hyd	P12701	1	
17	Clamp, 11/16 Worm	P12739	8	
18	Fitting, 1/4NPTx1/4JIC Male Elbow	P09142	1	
19	Fitting, 3/8" NPT - 3/8" Barb Elbow	P12708	1	
20	Fitting, 3/8" Barb Tee	015485	1	
21	Manifold, 1.2" W/Filter	P22683	1	
22	Fitting, 1/2" NPT - 3/8" Barb Elbow	P12707	2	
23	Bolt, 1/4-20 x 1/2" Hex Head Zinc Grade 2	F05005-15	2	
24	Washer, Z6.1 Split Lock Zinc	F81053-3	2	
25	Solenoid, 200A 12V SPST Hyd. Pump 1997	015470	1	
26	Bolt, M6X20-8.8-B, Hex Head Full Thread Zinc	F81001-2	2	
27	Washer, 6.4 Flat Zinc	F81053-1	6	
28	Nut, M6-8-B Hex Nylon Zinc Lock	F81031-2	2	
29	Nut, M5-8 Hex Zinc	F81030-1	4	
30	Valve, MTKA.VB Oil Flow Control	093794	1	
31	Fitting, M22x1.5 / 1/4 - 18 NPT Zinc	093139-1	2	
32	Fitting, VMNW10HS22	094486	1	
33	Fitting, PN10AOL13-90 Elbow	094485	1	
34	Fitting, 1/4NPTx1/4JIC Male	P09143	1	
35	Fitting, 3/8 JIC - 1/4 NPT 90L	015491	2	
36	Bolt, M6x45-8.8 Hex Head Zinc	F81001-6	2	
37	Plate, MTKA Control Valve Spacer Zinc-Plated	094477-1	1	
38	Nut, M6-8-B Hex Nylon Zinc Lock	F81031-2	2	
39	Valve, HDS11/10 6-Section Hydraulic	091344	1	
40	Bolt, M10x20-5.8 Hex Head Full Thread Zinc	F81003-1	2	
41	Fitting, #6 SAE Male - 1/4" NPT Female	014686	2	
42	Fitting, 1/4NPT Branch Tee	015486	1	
43	Plug, 1/4" NPT Blank	096221	1	
44	Fitting, 1/4" NPT x 3/8" Hose Barb	014685	1	
45	Fitting, 3/8" O-Ring - 3/8" JIC	014687	5	
46	Fitting, #4 SAE - #6 SAE 45° Elbow	015488	7	
47	Fitting, #6 SAE 45° Elbow	015489	1	
48	Fitting, 3/8" O-Ring - 1/4" JIC	P26284	7	
49	Plate, 10-Section Valve Painted	091826-1	1	
50	Guard, 10-Section Valve Rubber	091739	1	
51	Screw, #10-24x1/2 Self-Tapping	F05015-7	8	
52	Bolt, M5x12-5.8 Hex Head Full Thread Zinc	F81000-5	4	

<b>53</b>	Washer, 5.5 Special Flat Zinc-Plated	F81052-3	8	
<b>54</b>	Decal, DH5 Hydraulic Control Box	094795	1	
	Decal, DH7 Hydraulic Control Box	094970	1	

### 9.7 Hydraulic Power Supply Strip (DC)

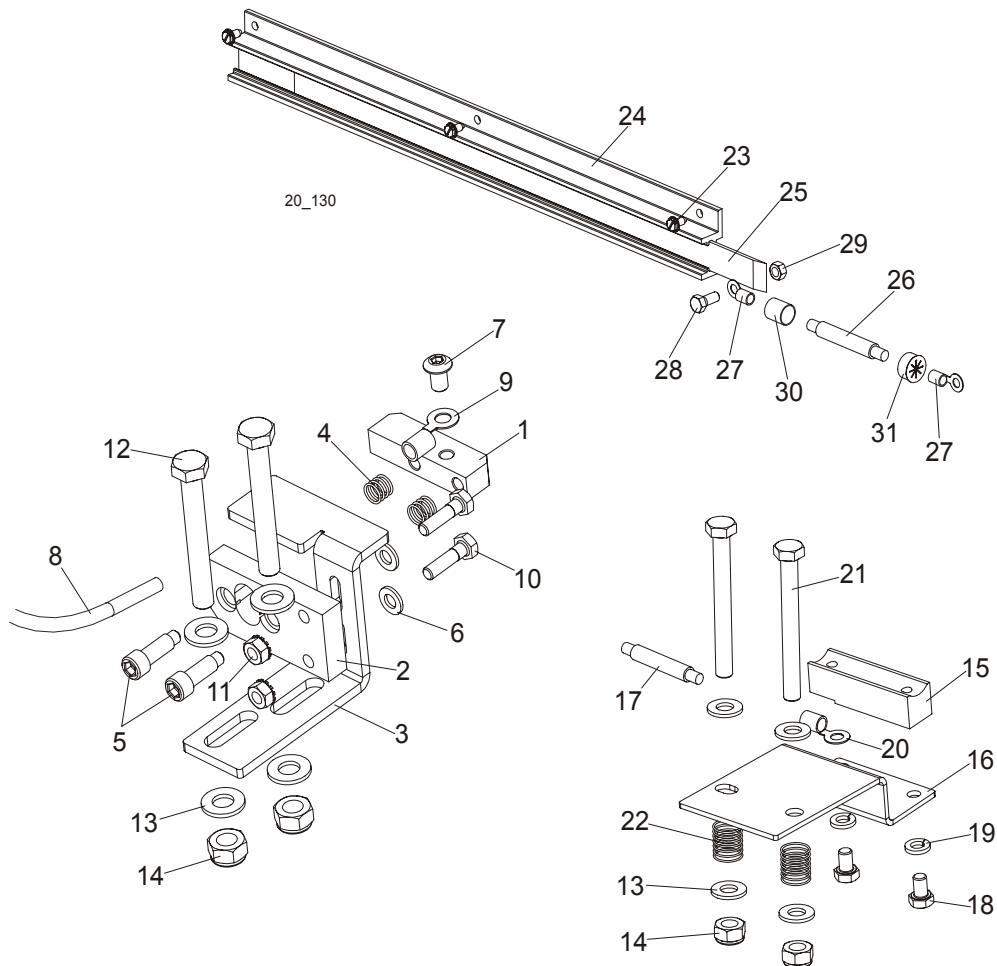

REF	DESCRIPTION (◆ Indicates Parts Available in Assemblies Only)	PART #	QTY.	
	<b>CONTACT ASSEMBLY, LT20 HYDRAULIC POWER SUPPLY (POSITIVE)</b>	097922	1	
1	Contact, Hydraulic Power Supply (Positive)	015253	1	
2	Insulator, Positive Contact	S10072	1	
3	Bracket, Positive Contact Mounting	097911-1	1	
4	Spring, Positive Contact	P10077	2	
5	Bolt, 5/16" X 3/4" Shoulder (1/4-20 Thread)	F05006-44	2	
6	Washer, 7.4 Flat	F81056-11	2	
7	Bolt, 5/16-24 x 3/8" Socket Button Head Zinc	F05006-20	1	
8	Cable, H07V-K BK 1x50	R80591-1	0.7m	◆
9	Terminal, KO 1/10	F81066-3	1	
10	Bolt, 1/4-20 X 1" Hex Head Grade 2	F05005-38	2	
11	Nut, 1/4-20 Hex Self-Locking	F05010-9	2	
12	Bolt, M10x75-8.8-Fe/Zn5 PN-M/82101	F81003-15	2	
13	Washer, 10.5 Flat	F81055-1	6	
14	Nut, M10 Hex Nylon Zinc Lock	F81033-1	4	

	<b>CONTACT ASSEMBLY, LT20 HYDRAULIC POWER SUPPLY (GROUND)</b>	097923	1	
15	Contact, Hydraulic Power Supply (Ground)	015264	1	
16	Bracket, Ground Contact Mounting	097912-1	1	
17	Cable, H07V-K BK 1x50	R80591	.76m	◆
18	Bolt, 5/16-18x1/2 HH Gr5	F05006-15	2	
19	Washer, 8.2 Split Lock	F81054-4	2	
20	Terminal, KO50/8	F81067-2	1	
21	Bolt, M10x90 -8.8-B- Fe/Zn5 PN/M-82101	F81003-66	2	
22	Spring, Ground Contact	P04282	2	
	<b>STRIP ASSEMBLY, LT20 HYDRAULIC POWER SUPPLY</b>	097916	1	
23	Screw, 1/4-20 X 1/2" Slotted Hex Head	F05015-1	3	
24	Housing, Contact Strip	097915	1	◆
25	Strip, Contact	097914	1	◆
26	Cable, H07V-K BK 1x50	R80591-1	1.9m	◆
27	Terminal, KO 50/8	F81067-2	2	
28	Bolt, 5/16-18 X 3/4" Hex Head Black Nylon	F05006-45	1	
29	Nut, 5/16-18 Hex Black Nylon	F05010-86	1	
30	Tube, RC19/9,5 Heat Shrink Black	R80600-3	.14 m	◆
31	Grommet, HEYCO Wire	P04137	1	

### 9.8 Hydraulic System Switch (AC)

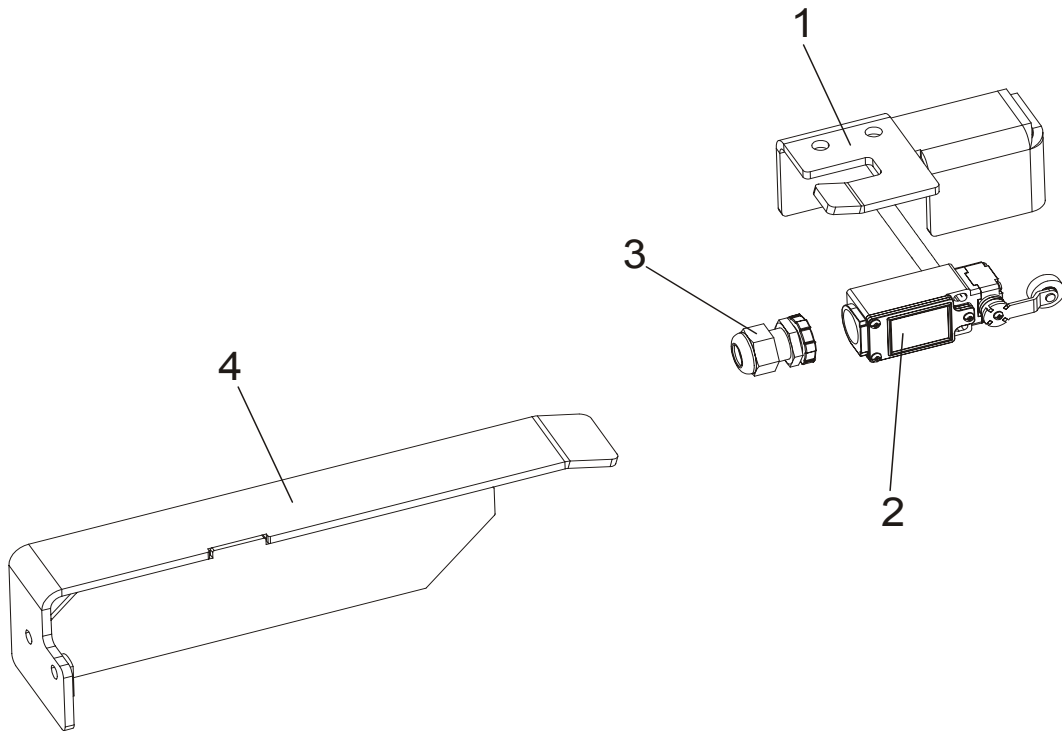

REF	DESCRIPTION (◆ Indicates Parts Available In Assemblies Only)	PART #	QTY.	
1	BRACKET, LOADING POSITION LIMIT SWITCH	092723-1	1	
2	LIMIT SWITCH, GLCB01A1B	100931	1	
3	STUFFING-BOX, SKINTOP PG 13,5	086524	1	
4	PLATE, LIMIT SWITCH ACTIVATOR PTD	092738-1	1	



## 9.9 Hydraulic Log Loader

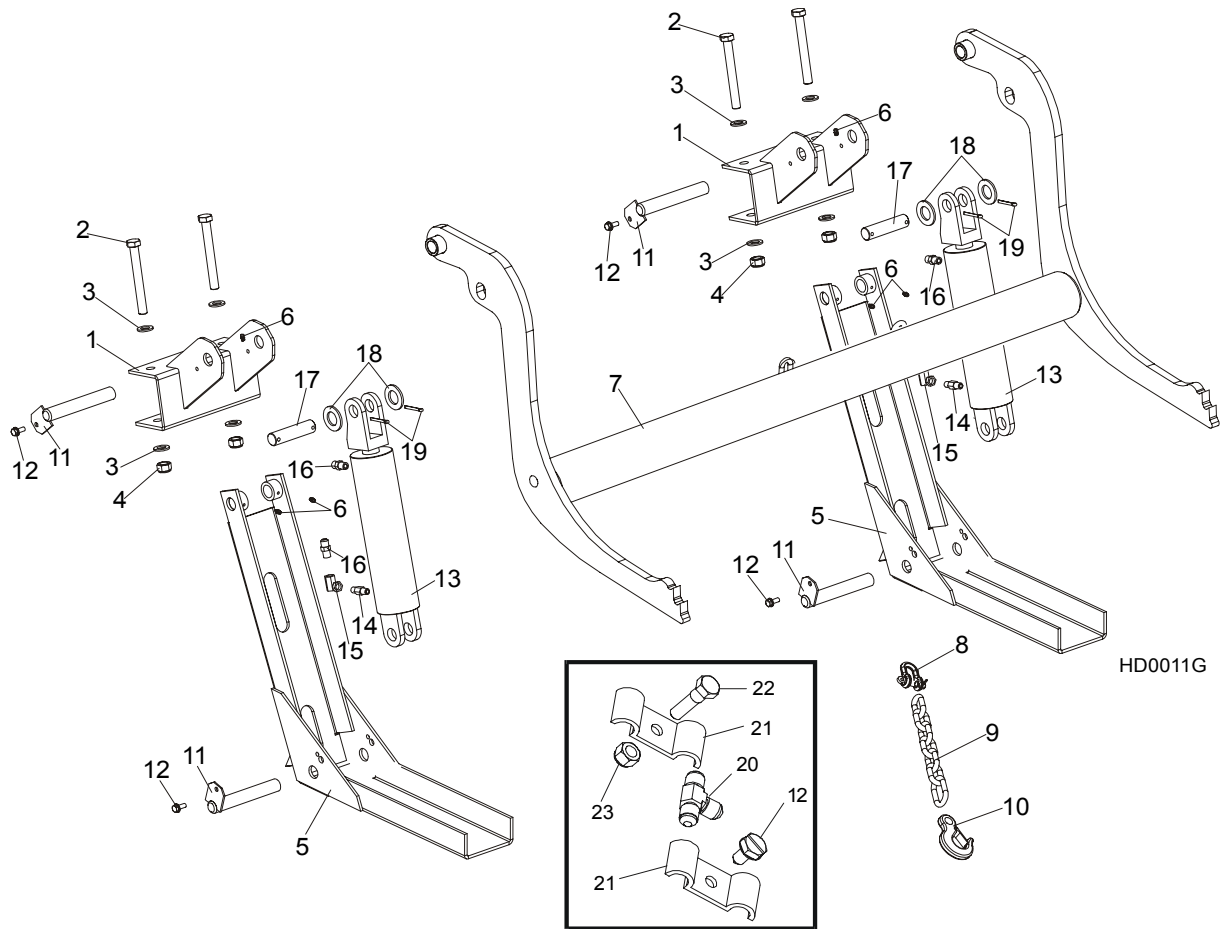

REF	DESCRIPTION (◆ Indicates Parts Available In Assemblies Only)	PART #	QTY.
	<b>HYDRAULIC LOG LOADER - COMPLETE</b>	092863	1
1	Bracket, Log Loader Mount	092865-1	1
2	Bolt, M16x140-8.8 Hex Head Zinc	F81006-4	4
3	Washer, 17 Flat Zinc	F81058-1	8
4	Nut, M16-8 Hex Nylon Zinc Lock	F81036-2	4
5	Channel, Hydraulic Log Loading Foot Complete	090049	2
5	Channel, Hydraulic Log Loading Foot	090048-1	2
6	Fitting, 3/16x3/16 Straight Grease	P04107	6
7	Arm, Hydraulic Log Loading Complete	090044	1
7	Arm, Hydraulic Log Loading	090006-1	1
8	Shackle, M-D .63	086540	1
9	Chain, Hydraulic Log Loader Safety	090007-1	1
10	Hook, 5/8 Safety Chain	P12075	1
11	Pin, Turner Arm	099127-1	4
12	Screw, 5/16-18x3/4 Self-Tapping	F05015-30	4
13	Cylinder Assy, Log Loading Super	015562	2

14	Fitting, 1/4NPT Velocity Fuse 5.0GPM	015750	2	
15	Fitting, 1/4NPT-1/4JIC Swivel Elbow	P12199	2	
16	Fitting, 3/8JIC-1/4NPT Straight	015560	4	
17	Washer, 28 Flat Zinc	F81061-1	4	
18	Fitting, 1/4JIC Union Tee	P09145	2	
19	Fitting, 3/8 Barb Tee	015485	1	
20	Plate, 1/4 Hose Clamp Painted	S09245	6	
21	Clamp, 3/8 Hose	016041	2	
22	Bolt, 5/16-18x1 Hex Head Zinc Grade 2	F05006-1	1	
23	Nut, 5/16-18 Self-Locking Nylon Zinc	F05010-58	1	

## 9.10 Hydraulic Log Turner

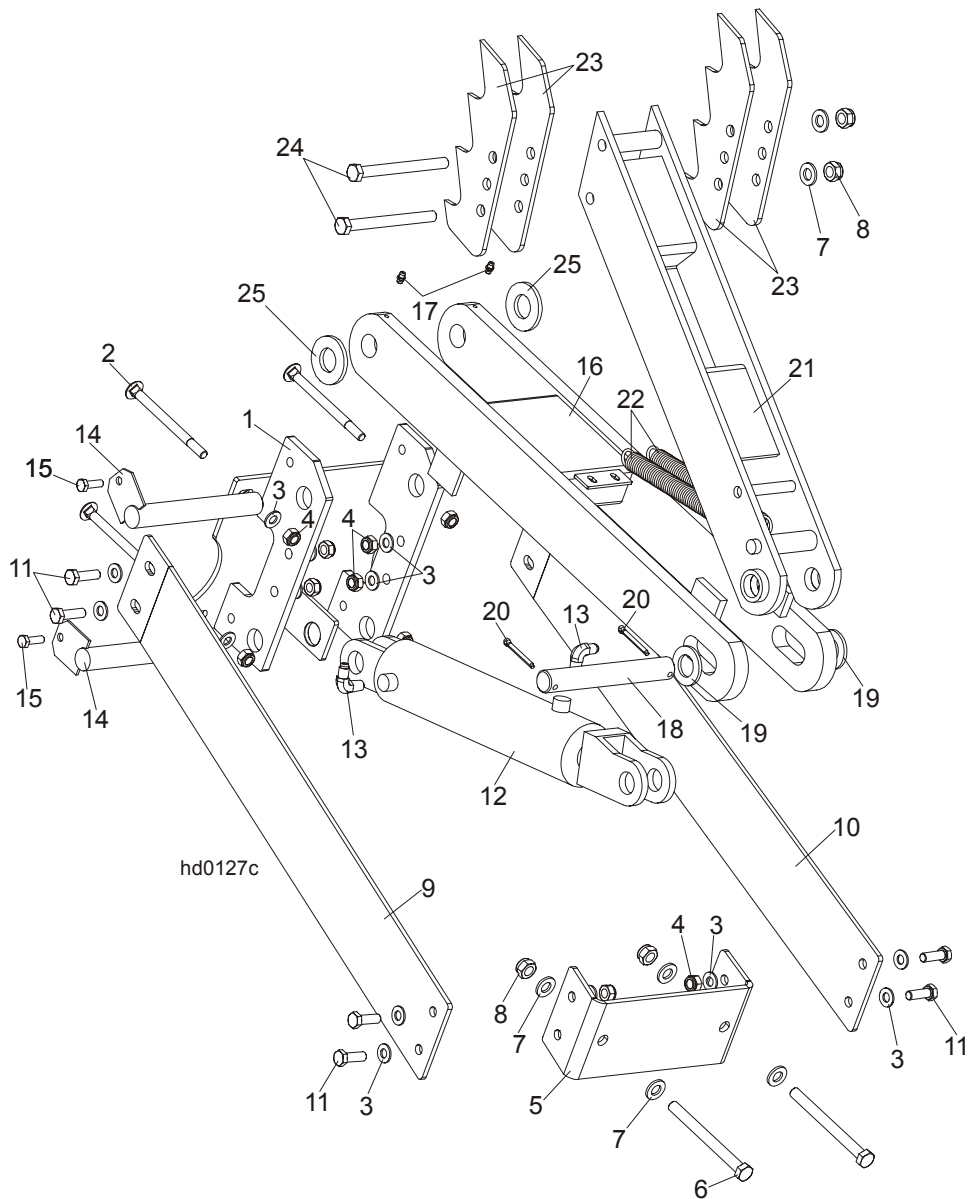

REF	DESCRIPTION (◆ Indicates Parts Available In Assemblies Only)	PART #	QTY.
	<b>HYDRAULIC LOG TURNER OPTION (S/M TYPE FRAME)</b>	088711	1
1	Bracket, Hydraulic Log Turner (S/M TYPE FRAME)	088710-1	1
2	Bolt, M10x120 8.8 Carriage Head Zinc	F81003-33	4
3	Washer, 10.5 Flat Zinc	F81055-1	20
4	Nut, M10-8-B Hex Nylon Zinc Lock	F81033-1	12
5	Bracket, Hydraulic Log Turner Front	091046-1	1
6	Bolt, M12x130-8.8 Hex Head Zinc	F81004-36	2
7	Washer, 13 Flat Zinc	F81056-1	6
8	Nut, M12-8 Hex Nylon Zinc Lock	F81034-2	4

9	Plate, Hydraulic Log Turner Left	091048-1	1	
10	Plate, Hydraulic Log Turner Right	091049-1	1	
11	Bolt, M10x30-5.8 Hex Head Full Thread Zinc	F81003-2	8	
	Cylinder Assy, Log Turner Super	015563	1	
12	Cylinder, CJ-S305-16-63/28/203 Hydraulic	088679	1	
13	Fitting, 1/4NPTx1/4JIC Male Elbow	P09142	2	
14	Pin, Log Turner Mount	088667-1	2	
15	Bolt, M8x25-8.8-B Hex Head Full Thread Zinc	F81002-5	2	
16	Arm, Hydraulic Log Turner Link	088060-1	1	
17	Fitting, M6 Grease	086280	2	
18	Pin, 25 X 180	088664	1	
19	Washer, 25 Flat Zinc	F81061-3	2	
20	Pin, 5x40 Cotter	F81043-31	2	
21	Arm, Hydraulic Log Turner Painted	088067-1	1	
22	Spring, 7/8x8 1/2x1/8 Extension	P09136	2	
23	Claw, Hydraulic Log Turner	088082-1	4	
24	Bolt, M12x130-8.8 Hex Head Zinc	F81004-36	2	
25	Washer, GTM-2644-015	093359	2	

## 9.11 Hydraulic Log Side Supports

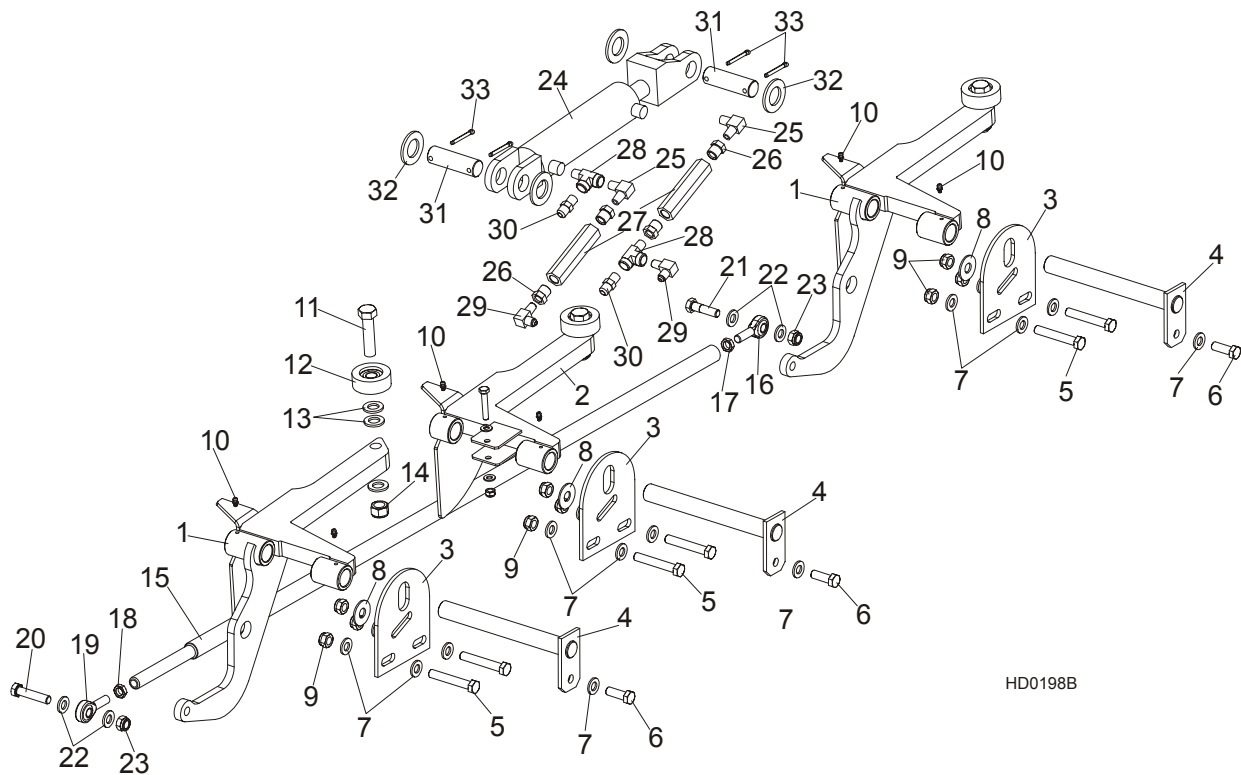

REF	DESCRIPTION (◆ Indicates Parts Available In Assemblies Only)	PART #	QTY.
	<b>LOG SIDE SUPPORT KIT, S/M FRAME</b>	092611	1
1	SUPPORT, HYDRAULIC LOG SIDE W/GUARD	099788-1	2
2	SUPPORT, LOG SIDE W/GUARD	099785-1	1
3	PLATE, LOG SIDE SUPPORT END	091591-1	3
4	PIN, LOG SIDE SUPPORT PIVOT	091549-1	3
5	BOLT, M12 X 75-8.8 HEX HEAD FULL THREAD ZINC	F81004-21	6
6	BOLT, M12 X 35-8.8 HEX HEAD FULL THREAD ZINC	F81004-24	3
7	WASHER, 13 FLAT ZINC	F81056-1	15
8	WASHER, 15 FLAT SPECIAL ZINC-PLATED	F81057-3	3
9	NUT, M12-8 HEX NYLON ZINC LOCK	F81034-2	9
10	FITTING, 3/16" STRAIGHT GREASE	P04107	6
11	BOLT, M16X65-8.8 HEX HEAD FULL THREAT	F81006-1	3
12	ROLLER ASSY, SIDE SUPPORT, PTD	015014-1	3
13	WASHER, 17 FLAT ZINC	F81058-1	9
14	NUT, M16,HEX, NYLON ZINC LOCK	F81036-2	3
	ROD, SIDE SUPPORT LINK COMPLETE	091640	1
15	ROD, SIDE SUPPORT LINK ZINC-PLATED	089374-1	1
16	ROD END (LEFT THREAD)	087036	1
17	NUT, M12-04-A RIGHT HEX THIN	F81034-6	1
18	NUT, M12-04-A LEFT HEX THIN	F81034-7	1

19	ROD END (RIGHT THREAD)	087035	1	
20	BOLT, M12 X 55-8.8 HEX HEAD FULL THREAD ZINC	F81004-12	1	
21	BOLT, M12 X 45-8.8 HEX HEAD FULL THREAD ZINC	F81004-32	2	
22	WASHER, 13 FLAT ZINC	F81056-1	4	
23	NUT, M12-8 HEX NYLON ZINC LOCK	F81034-2	2	
	CYLINDER ASSEMBLY, SUPER HYDRAULIC LOG SIDE SUPPORT	015561	1	
24	CYLINDER, CJ-S270-16-50/28/152 HYDRAULIC	088678	1	
	SEAL KIT, 6" X 2" HYDRAULIC CYLINDER	P12954	1	
25	FITTING, #C3529X4 90° ELBOW	P09140	2	
26	FITTING, 3/8" NPT - 1/4" NPT REDUCER	015490	4	
27	VALVE, SIDE SUPPORT SEQUENCE	015484	2	
28	FITTING, C3759X4 MALE TEE	P09141	2	
29	FITTING, C3759X4 MALE TEE	P09141	2	
30	FITTING, 3/8" JIC - 1/4" NPT STRAIGHT	015560	2	
31	PIN, HYDRAULIC CYLINDER ZINC-PLATED	086979-1	2	
32	WASHER, 28 FLAT ZINC	F81061-1	4	
33	PIN, 5 X 40 COTTER	F81043-31	4	

## 9.12 Hydraulic Log Clamp, Main

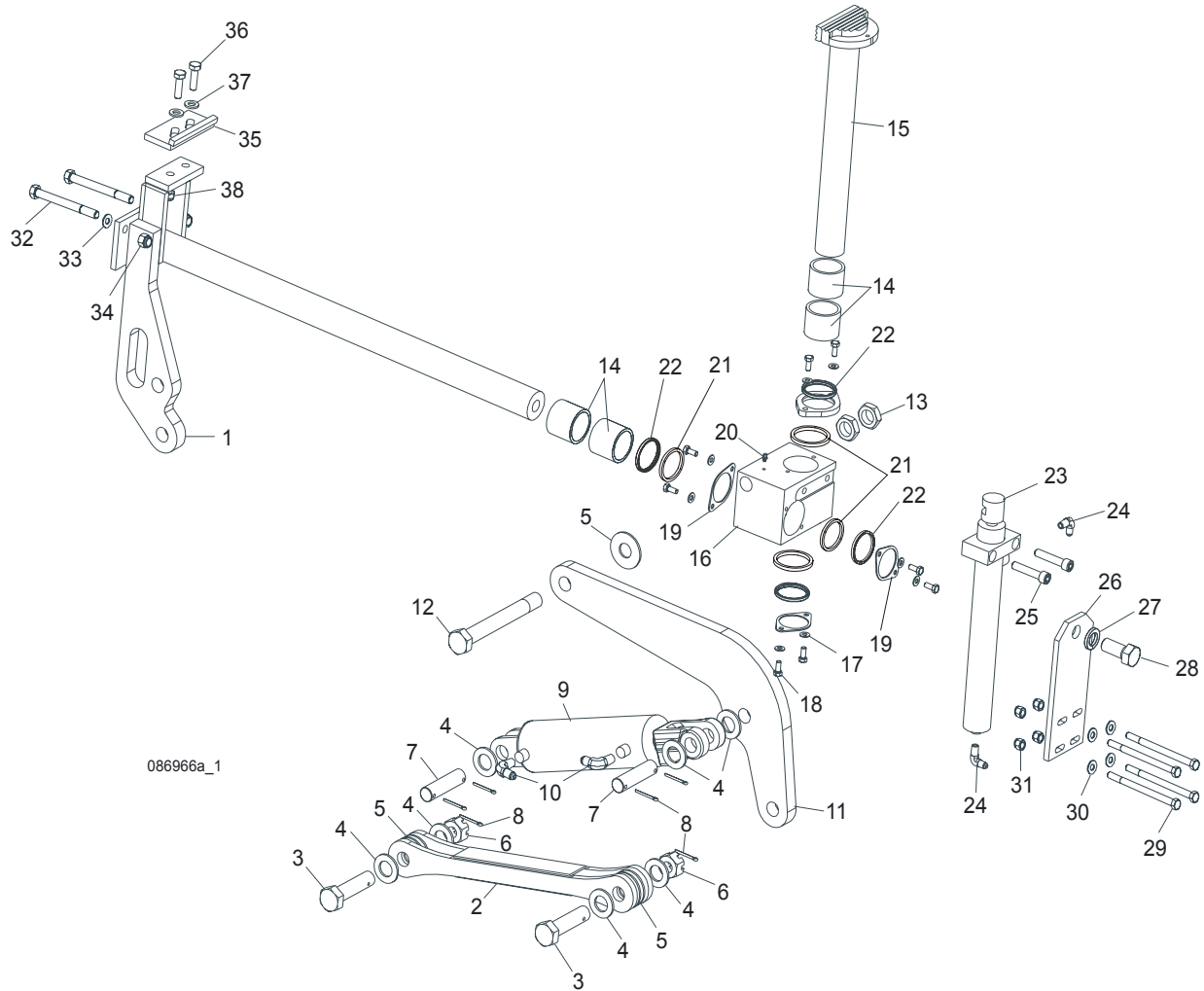

086966a\_1

REF	DESCRIPTION (◆ Indicates Parts Available In Assemblies Only)	PART #	QTY.
	<b>LOG CLAMP ASSEMBLY, TWO-PLANE</b>	088658	1
1	Rod Weldment, Log Clamp Slide Painted	086967-1	1
2	Arm Weldment, Hydraulic Clamp Link Painted	086963-1	1
3	Pin, B 24x95/85 Clevis Zinc	F81049-2	1
4	Washer, 25 Flat Zinc	F81061-3	8
5	Washer, 25x63 Zinc-Plated	088585-1	5
6	Nut, M20-8-3 Hex Slotted Castle Zinc	F81037-3	2
7	Pin, Hydraulic Cylinder Zinc-Plated	086979-1	2
8	Pin, 6.3x45 Cotter Zinc	F81045-2	6
9	Cylinder, CJ-S96-16-70/32/178 Hydraulic	088589	1
10	Fitting, 1/4" NPT - 1/4" JIC Male Elbow	P09142	2
11	Arm, Hydraulic Log Clamp Link Painted	086974-1	1

12	Bolt, M24x217/39 -8.8-B Hex Head Zinc	088586-1	1	
13	Nut, M24 -04-B Hex Thin Zinc	F81039-3	2	
14	Bushing, 5040BS Self-Lubricating	088660	2	
15	Rod Weldment, Log Clamp Vertical Painted	088582-1	1	
16	Block, Log Clamp Painted Steel	088591-1	1	
17	Washer, 8.4 Flat Zinc	F81054-1	8	
18	Bolt, M8x20-8.8-B Hex Head Full Thread Zinc	F81002-4	8	
19	Flange, Clamp Rod Wiper Painted	088887-1	3	
20	Fitting, 3/16" Straight Grease	P04107	1	
21	Spacer, Log Clamp	089324	1	
22	Wiper, ZZ 50x60x7 INCO Log Clamp Rod	088587	1	
23	Cylinder, CJ-S169-16-40/22/254 Hydraulic	088590	1	
24	Fitting, 1/4" NPT - 1/4" JIC Male Elbow	P09142	2	
25	Screw, M12x55 -8.8-B Hex Socket Head Cap Zinc	F81004-23	2	
26	Plate, Log Clamp Mount Painted	086975-1	1	
27	Washer, Z 22.5 Split Lock Zinc	F81059-4	1	
28	Bolt, M22x1.5x40-8.8-B Hex Head Full Thread Zinc	F81009-1	1	
29	Bolt, M10x125-8.8 Hex Head Zinc	F81003-18	4	
30	Washer, 10.5 Flat Zinc	F81055-1	4	
31	Nut, M10-8-B Hex Nylon Zinc Lock	F81033-1	4	
32	Bolt, M12 x 140-8.8 Hex Head Zinc	F81004-37	2	
33	Washer, 13 Flat Zinc	F81056-1	2	
34	Nut, M12-8-B Hex Zinc	F81034-1	2	
	<b>STOP ASSEMBLY, LOG CLAMP</b>	K09485	1	
35	Stop Weldment, Hydraulic Log Clamp Painted	086980-1	1	
36	Bolt, M12 x 40-8.8 Hex Head Full Thread Zinc	F81004-4	2	
37	Washer, 13 Flat Zinc	F81056-1	2	
38	Nut, M12-8 Hex Nylon Zinc Lock	F81034-2	2	



### 9.13 Hydraulic Pull Down Clamp

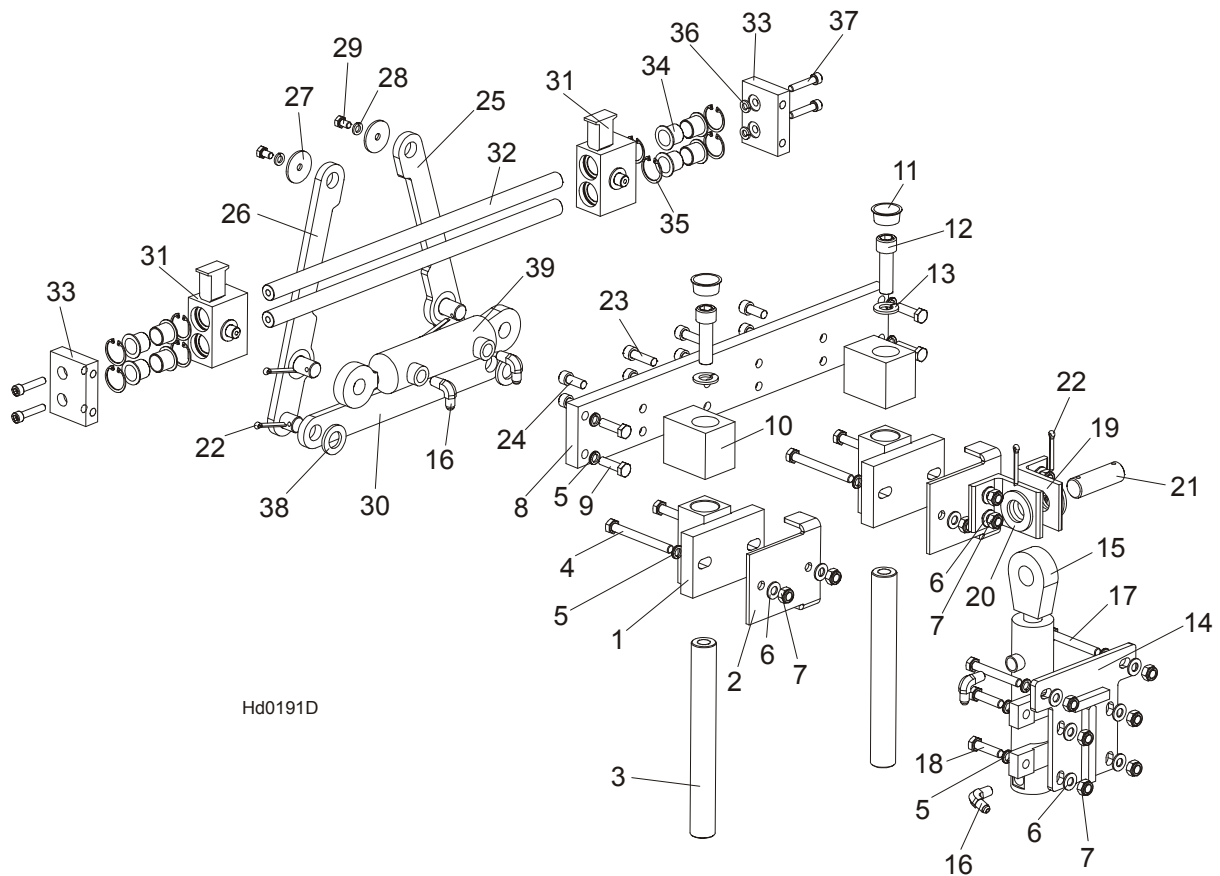

REF	DESCRIPTION (◆ Indicates Parts Available In Assemblies Only)	PART #	QTY.
	<b>LEFT HYDRAULIC LOG CLAMP ASSEMBLY (REAR)</b>	094129	1
1	Block Weldment, Log Clamp Up/Down Painted	090545-1	2
2	Bracket, Log Clamp Mount Painted	094098-1	2
3	Pin, Log Clamp Up/Down	088631	2
4	Bolt, M10x95-8.8-B Hex Head Zinc	F81003-71	4
5	Washer, 10.2 Split Lock Zinc	F81055-2	14
6	Washer, 10.5 Flat Zinc	F81055-1	14
7	Nut, M10-8-B Hex Nylon Zinc Lock	F81033-1	14
8	Beam, Log Clamp Main Zinc-plated	094115-1	1
9	Bolt, M10x35-8.8 Hex Head Full Thread Zinc	F81003-17	4
10	Block, Log Clamp Up/Down Painted	094124-1	2
11	Plug, M33 Thread #12428	089839	2
12	Screw, M16x55-8.8 Hex Socket Head Cap Zinc	F81006-18	2
13	Washer, 16.3 Split Lock Zinc	F81058-2	2
14	Plate Weldment, Hydraulic Cylinder Mounting Painted	094094-1	1

15	Cylinder, CJ7F-16/40/22 + UE2-40W Hydraulic	091346	1	
16	Fitting, 90° Male Elbow	P09142	2	
17	Bolt, M10x75-8.8 Hex Head Zinc	F81003-15	2	
18	Bolt, M10x40-8.8 Hex Head Full Thread Zinc	F81003-16	4	
19	Bracket, Hydraulic Cylinder Mounting Painted	094127-1	2	
20	Washer, 28 Flat Zinc	F81061-1	2	
21	Pin, 25X75 Zinc-plated	088659-1	1	
22	Pin, S-Zn 5x40 Cotter Zinc	F81043-31	4	
23	Screw, M10x35 8.8 Hex Socket Head Cap Zinc	F81003-56	4	
24	Screw, M10x25 8.8 Hex Socket Head Cap Zinc	F81003-32	4	
25	Link, Log Clamp In/Out Side Zinc-plated (1)	094097-1	1	
26	Link, Log Clamp In/Out Side Zinc-plated (2)	094099-1	1	
27	Washer, Zinc-plated Spacer	094128-1	1	
28	Washer, 8.2 Split Lock Zinc	F81054-4	2	
29	Bolt, M8x12-8.8 Hex Head Full Thread Zinc	F81002-6	2	
30	Arm, Log Clamp In/Out Zinc-plated	094092-1	1	
31	Jaw Weldment, Log Clamp Zinc-plated	094120-1	2	
32	Rod, Log Clamp Jaw Guide	094116	2	
33	Plate, Locking Zinc-plated	094117-1	2	
34	Bushing, JFM-2023-21 Flanged	094113	8	
35	Ring, W 31 Inside Retaining	F81090-15	8	
36	Washer, 8.2 Split Lock Zinc	F81054-4	4	
37	Screw, M8x40-8.8 Hex Socket Head Cap Zinc	F81002-29	4	
38	Washer, 21 Flat Zinc	F81059-2	2	
39	Cylinder SJ2F-16-40/22/80 Hydraulic	093880	1	

### 9.14 Hydraulic Toe Board

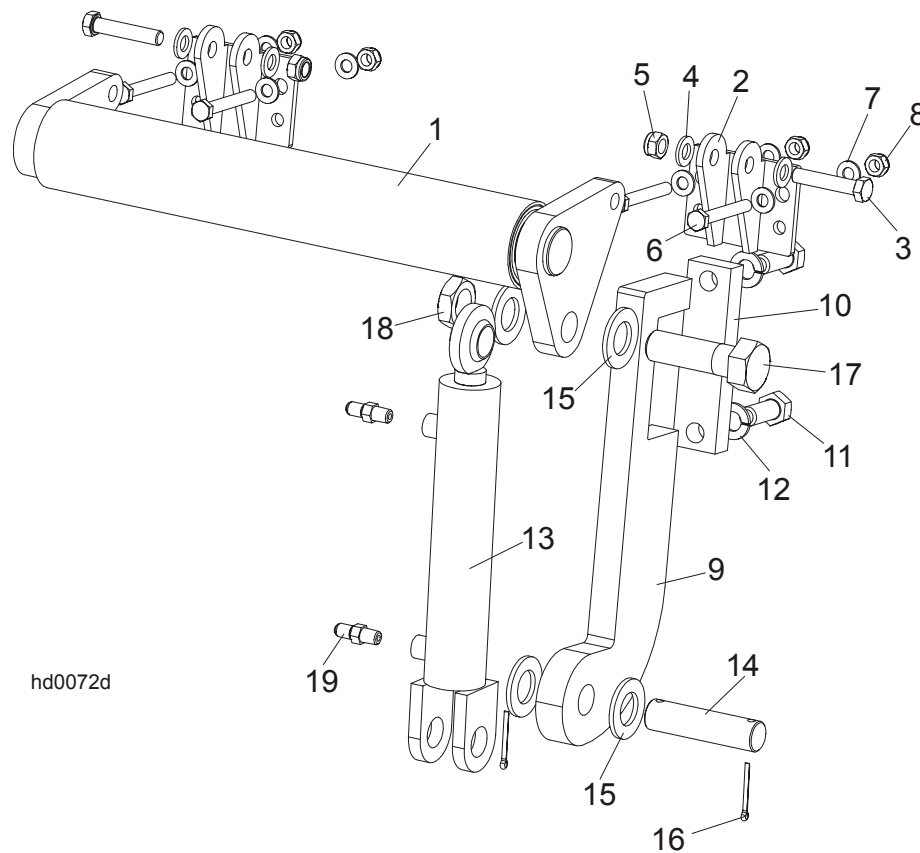

hd0072d

REF	DESCRIPTION (◆ Indicates Parts Available In Assemblies Only)	PART #	QTY.
	<b>FRONT HYDRAULIC TOE BOARD</b>	092613	1
	<b>REAR HYDRAULIC TOE BOARD</b>	092634	1
1	Toe Board Weldment, Front Hydraulic Painted	092612-1	1
	Toe Board Weldment, Rear Hydraulic Painted	086253-1	1
2	Bracket, Toe Board Roller Mount	087903-1	2
3	Bolt, M12x60-8.8 Hex Head Zinc	F81004-5	4
4	Washer, 13 Flat Zinc	F81056-1	8
5	Nut, M12-8 Hex Nylon Zinc Lock	F81034-2	4
6	Bolt, M10x75-8.8 Hex Head Zinc	F81003-15	8
7	Washer, 10.5 Flat Zinc	F81055-1	16
8	Nut, M10-8-B Hex Nylon Zinc Lock	F81033-1	8
9	Bracket, Toe Board Cylinder Mount Painted	087729-1	2
10	Plate, Toe Board Cylinder Mount	090086-1	2
11	Bolt, M16x40-8.8 Hex Head Full Thread Zinc	F81006-13	4
12	Washer, 16.3 Split Lock Zinc	F81058-2	4
13	Cylinder, CJ-S170-16-40/25/152 Hydraulic	088681	2
14	Pin, Hydraulic Cylinder Zinc-Plated	086979-1	2
15	Washer, 28 Flat Zinc	F81061-1	8
16	Pin, 3/16x1.5" Cotter Zinc	F05012-23	4

17	Bolt, 1"-8 x 3 1/4 Hex Head Grade 5	F05009-51	2	
18	Nut, 1"-14" Hex Jam Unplated	F05010-117	2	
19	Fitting, C5205x4x4 Male	P09143	4	