

D22 Engine

Safety, Operation, Maintenance & Parts Manual

LT20

rev. A1.03



Safety is our #1 concern! Read and understand all safety information and instructions before operating, setting up or maintaining this machine.

January 2004

Form #618

Table of Contents

Section-Page

SECTION 1	SAFETY & GENERAL INFORMATION	1-1
1.1	Refueling	1-1
1.2	Engine Operation.....	1-2
1.3	Battery Handling	1-4
1.4	General Information	1-5
SECTION 2	OPERATION	2-1
2.1	Starting The Engine.....	2-1
SECTION 3	MAINTENANCE	3-1
3.1	Engine Oil & Filter	3-2
3.2	Air Cleaner	3-4
3.3	Cooling System	3-5
3.4	Primary Fuel Filter	3-6
3.5	Battery	3-7
3.6	Alternator Belt.....	3-7
3.7	Drive Belt Adjustment.....	3-8
3.8	Clutch Handle Adjustment	3-9
3.9	Miscellaneous Maintenance	3-10
3.10	RPM Adjustments	3-11
3.11	Storage.....	3-12
SECTION 4	REPLACEMENT PARTS	4-1
4.1	How To Use The Parts List	4-1
4.2	Sample Assembly	4-1
4.3	Fuel Tank Assembly.....	4-2
4.4	Engine Mount Assembly	4-4
4.5	Engine Assembly.....	4-5
4.6	Drive Assembly	4-6
4.7	Throttle Assembly	4-7
4.8	Radiator Assembly	4-9
SECTION 5	ELECTRICAL INFORMATION	5-1
5.1	Electrical Wiring Diagram, D22 Engine	5-1
5.2	Electrical Components, DP22-20S.....	5-3

SECTION 1 SAFETY & GENERAL INFORMATION



IMPORTANT! This manual is provided as a supplement to the equipment manufacturer's manuals. This manual takes into account the specific use of engines on the Wood-Mizer sawmill. Only safety, maintenance, and operating procedures that are not provided by the manufacturer are supplied in this manual. Refer to the manufacturer's manual before attempting to operate this equipment.



This symbol calls your attention to instructions concerning your personal safety. Be sure to observe and follow these instructions. This symbol accompanies a signal word. The word **DANGER** indicates an imminently hazardous situation which, if not avoided, will result in death or serious injury. **WARNING** suggests a potentially hazardous situation which, if not avoided, could result in death or serious injury. **CAUTION** refers to potentially hazardous situations which, if not avoided, may result in minor or moderate injury to persons or equipment. Read all safety instructions before operating this equipment and observe all safety warnings!

1.1 Refueling



DANGER! Due to the flammable nature of fuel and oil, never smoke, weld, grind or allow sparks near your engine or storage tanks, especially during times of fueling.

DANGER! Never allow fuel to spill on a hot engine during fueling operations or otherwise. The hot temperature of your engine could induce a fire or explosion.



WARNING! Store gasoline away from sawdust and other flammable materials. Failure to do so may result in serious injury.

1.2 Engine Operation



DANGER! Operate your engine/machine only in well ventilated areas. The exhaust gases of your engine can cause nausea, delirium and potentially death unless adequate ventilation is present.

DANGER! Never operate an engine with a fuel or oil leak. The leaking fuel or oil could potentially come in contact with hot surfaces and ignite into flames.

DANGER! Engine components can become very hot during operation. Avoid contact with any part of a hot engine. The exhaust components of your engine are especially hot during and following operation. Contact with hot engine components can cause serious burns. Therefore, never touch or perform service functions on a hot engine. Allow the engine to cool sufficiently before beginning any service function.

DANGER! Always be aware of and take proper protective measures against rotating shafts, pulleys, fans, etc. Always stay a safe distance from rotating members and make sure that loose clothing or long hair does not engage rotating members resulting in possible injury.

DANGER! Always be sure the blade is disengaged and all persons are out of the path of the blade before starting the engine or motor. Failure to do so will result in serious injury.



WARNING! Do not for any reason adjust the engine drive belts or belt support bracket with the engine running. Doing so may result in serious injury.

WARNING! Do not operate engine without proper and operational spark arrester/muffler. Sparks emitted from the engine exhaust could ignite surrounding materials, causing serious injury or death.

WARNING! Remove the blade before performing any engine service. Failure to do so may result in serious injury.



WARNING! Always disconnect the machine battery cables before performing service functions. Diesel engines by default require diesel fuel and lubricating oil for operation. Both diesel fuel and lubricating oil are flammable. Disconnection of the battery cables will reduce the possibility of sparks with potentially resultant fires or explosions.



WARNING! Be sure the power feed switch is in the neutral position before turning the key switch to the on (#1) or accessory (#3) position. This prevents accidental carriage movement, which may cause serious injury or death.

WARNING! Always wear proper and necessary safety equipment when performing service functions. Proper safety equipment includes eye protection, breathing protection, hand protection and foot protection.

WARNING! The engine exhaust from this product contains chemicals known to the State of California to cause cancer, birth defects or other reproductive harm.



IMPORTANT! Always dispose of coolant, oil, fuel, oil filters and fuel filters in a responsible manner and in conformance with local, state and federal regulations.



CAUTION! Do not crank starter for more than 7 seconds at one time during starting attempts. Damage to the engine may result.

CAUTION! During the initial 50 hours, do not exceed 70% of the maximum rated power. Damage to the engine may result.

CAUTION! Do not adjust the high-end RPM above 3200. Doing so may cause damage to the engine.

1.3 Battery Handling



DANGER! Batteries expel explosive gases. Keep sparks, flames, burning cigarettes, or other ignition sources away at all times. Always wear safety goggles and a face shield when working near batteries. Failure to do so will cause serious injury.¹



WARNING! Charge the battery in a well ventilated area. Do not attempt to charge a frozen battery.

WARNING! Use extreme care to avoid spilling or splashing electrolyte (which is dilute sulfuric acid) as it can destroy clothing and burn the skin. If electrolyte is spilled or splashed on clothing or the body, it should be neutralized immediately and then rinsed with clean water. A solution of baking soda, or household ammonia, and water may be used as a neutralizer.

Electrolyte splashed into the eyes is extremely dangerous. If this should happen, force the eye open and flood it with cool, clean water for approximately fifteen minutes. A doctor should be called immediately when the accident occurs and “on-the-spot” medical attention given if possible. If a doctor cannot come to the scene of the accident immediately, follow his instructions concerning actions to take. Do not add eye drops or other medication unless advised to do so by the doctor. Do not place a battery or acid within the reach of children. If acid (electrolyte) is taken internally drink large quantities of water or milk. Follow with milk of magnesia, beaten egg or vegetable oil. Call a physician immediately.

If electrolyte is spilled or splashed on any surface of the machine, it should be neutralized and rinsed with clean water.¹

1. Battery Council International, copyright 1987

1.4 General Information



IMPORTANT! Read the engine manual for instructions and safety precautions before operating the engine.

For use with the Wood-Mizer sawmill, the radiator, air cleaner, alternator, and starter used differ from Lombardini's standard components.

See **Figure 1-1**. The main components of the diesel engine are shown.

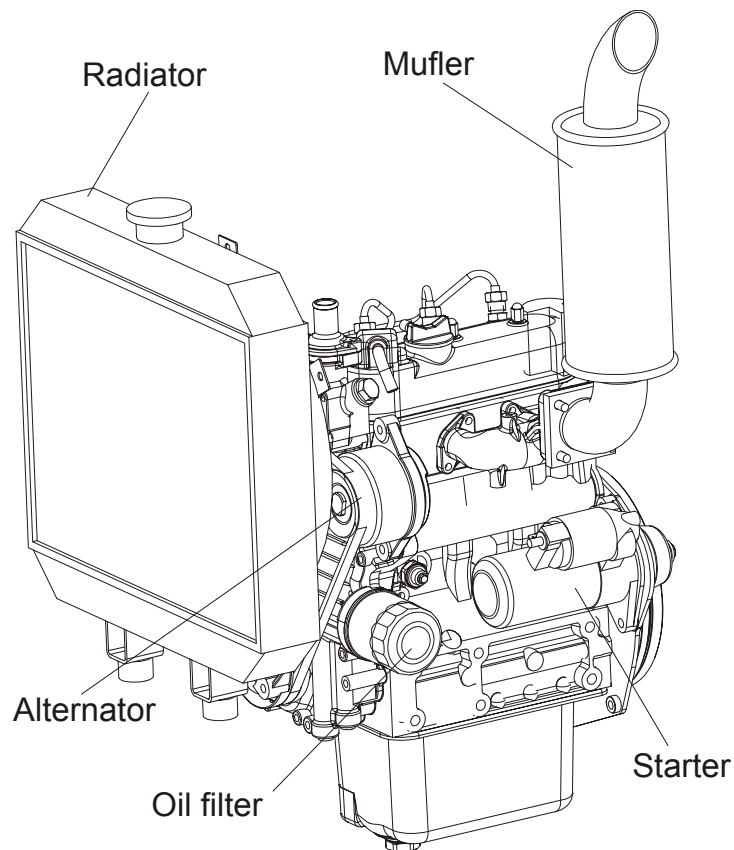

FIG. 1-1

SECTION 2 OPERATION

2.1 Starting The Engine

Engine Control Lights

Patrz rysunek 2-1. See the manufacturer's engine manual for troubleshooting tips.



NOTE: Indicator also lights up when engine is started and remains lit until engine initially reaches approximately 1300 RPM.



Engine Temperature Indicator: Lights up if the engine is overheating.



Oil Indicator



Glow Plug Indicator

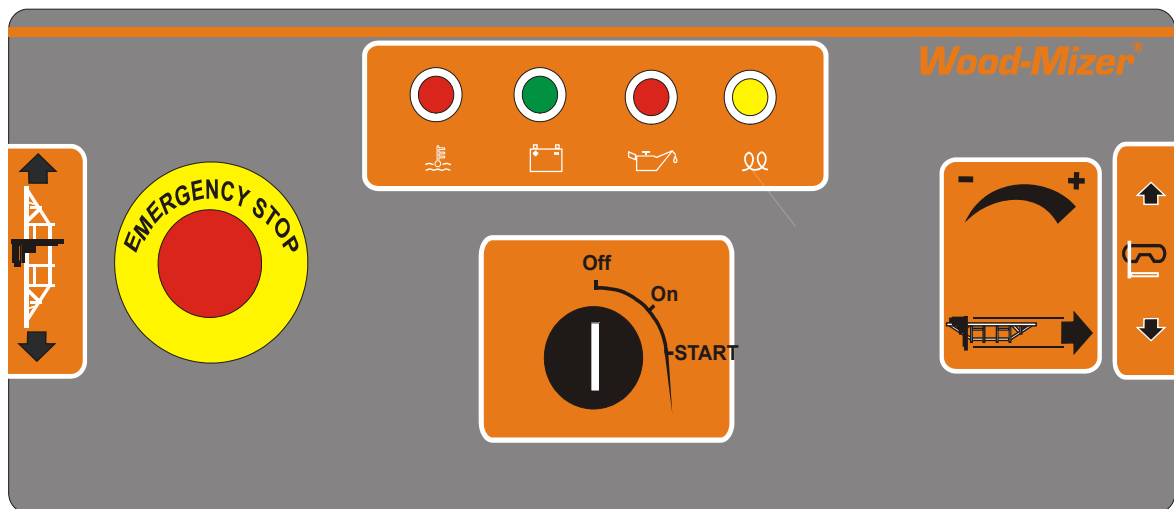

RYS. 2-1

NOTE: The glow plug indicator will go out after the engine is started.



CAUTION! Avoid leaving the key in the #1 position for more than 30 seconds while the engine is not running. Doing so will drain the sawmill battery which may reduce its service life.

Engine Start



DANGER! Always be sure the blade is disengaged and all persons are out of the path of the blade before starting the engine. Failure to do so will result in serious injury.



WARNING! Be sure the power feed switch is in the neutral position before turning the key switch to the on (#1) or accessory (#3) position. This prevents accidental carriage movement which may cause serious injury or death.



CAUTION! Should the glow indicator redden too quickly or too slowly, immediately ask your KUBOTA dealer to check and repair it.



CAUTION! If the engine does not catch or start within 10 seconds after turning the starter switch to the START position, wait another 30 seconds and then try to start the engine again. Do not crank starter for more than 20 seconds at one time during starting attempts.

2

OPERATION

Starting The Engine

1. See the engine manufacturer's manual for lubricating oil recommendations for specific temperature ranges.
2. Use #2 or better quality diesel fuel for above freezing starting. Use a #1 quality diesel fuel for below freezing starting.
3. Turn the key switch on the control panel to the ON (#1) position.
4. Turn the key switch to the start (#2) position and release.

Engine Shutoff

Turn the key switch to the OFF (#0) position.

SECTION 3 MAINTENANCE



IMPORTANT! This manual only provides information about additional procedures or procedures to be performed at different time intervals than found in the engine manufacturer's manuals. Refer to the manufacturer's manual for complete maintenance instructions.



DANGER! Engine components can become very hot during operation. Avoid contact with any part of a hot engine. The exhaust components of your engine are especially hot during and following operation. Contact with hot engine components can cause serious burns. Therefore, never touch or perform service functions on a hot engine. Allow the engine to cool sufficiently before beginning any service function.



WARNING! Remove the blade before performing any engine service. Failure to do so may result in serious injury.

WARNING! Always disconnect the machine battery cables before performing service functions. Diesel engines by default require diesel fuel and lubricating oil for operation. Both diesel fuel and lubricating oil are flammable. Disconnection of the battery cables will reduce the possibility of sparks with potentially resultant fires or explosions.

WARNING! Always wear proper and necessary safety equipment when performing service functions. Proper safety equipment includes eye protection, breathing protection, hand protection and foot protection.



This symbol identifies the interval (hours of operation) at which each maintenance procedure should be performed. "AR" signifies maintenance procedures which should be performed as required.

3.1 Engine Oil & Filter

Patrz rysunek 3-1. The following chart details lubricating oil viscosity as a function of ambient temperature. Select the lubricating oil viscosity based upon the prevailing temperature range expected. If your application will be subject to large ambient temperature ranges during a given oil change interval, select the lubricating oil viscosity based upon the highest temperature expected. Should the prevailing ambient temperatures change during a given oil service period interval, and the lubricating oil within the engine is reflective of a lower temperature range, the lubricating oil should be changed to reflect the prevailing temperature.

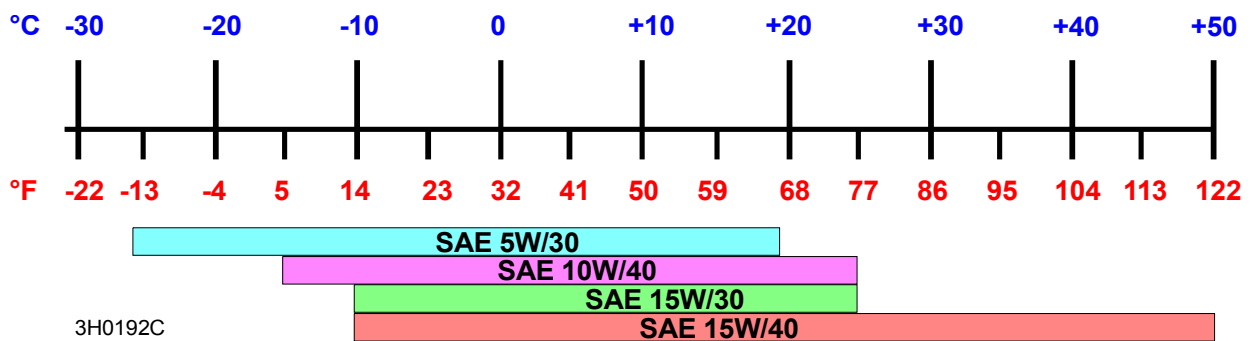

3H0192C

RYS. 3-1

Kubota recommends that only API (American Petroleum Institute) grades ‘CD’ or higher be used within Kubota diesel engines. In addition to the API rating, lubricating oils should also meet or exceed MIL-L-2104D. Without respect to brand name, lubricating oil meeting API grade ‘CD’ and sourced from a reputable supplier are acceptable for use within Kubota diesel engines.

See the table below for recommended types of engine oil depending on ambient temperature ranges.

Above 25°C	SAE30 or SAE10W-30 SAE10W-40
0 - 25°C	SAE20 or SAE10W-30 SAE10W-40
Less Than 0°C	SAE10W or SAE10W-30 SAE10W-40

TABLE 3-0

The use of “SEMI-SYNTHETIC” lubricating oils meeting the grade and viscosity guidelines presented above is acceptable and may reduce engine wear rates due to the superior characteristics of the “SEMI-SYNTHETIC” oil with respect to mineral based engine lubricating oils.

Kubota does not recommend the use of ANY oil additive other than those included within

the respective manufacturer oil blends. Under no circumstances should oil additives claiming “teflon”, “molecular adhesion”, low wear rates etc. be added. These aftermarket oil additives may actually break down the recommended lubricating oil chemical properties resulting in accelerated engine wear.

When operating in temperatures below those specified in the chart, [Patrz rozdział 2.2.](#)

Oil capacity (including oil filter) is **3.8** liters.



Check the oil level every 8 hours of operation. Add oil as necessary.



Change the oil and replace the oil filter after the first 50 hours of operation. Change the oil every 100 hours and replace the oil filter every 200 hours thereafter.



IMPORTANT NOTE! Before reinstalling the clean oil filter, wipe all dirt and oil deposits from the oil filter receptacle.

3.2 Air Cleaner

Since the air cleaner used on this engine is a dry type, do not oil it. Wipe the inside of the cleaner with a rag if it is dirty or wet. Avoid touching the element except while cleaning.

Open the rubber valve once a week under normal conditions or daily under dusty conditions to remove any large particles of dust and dirt.

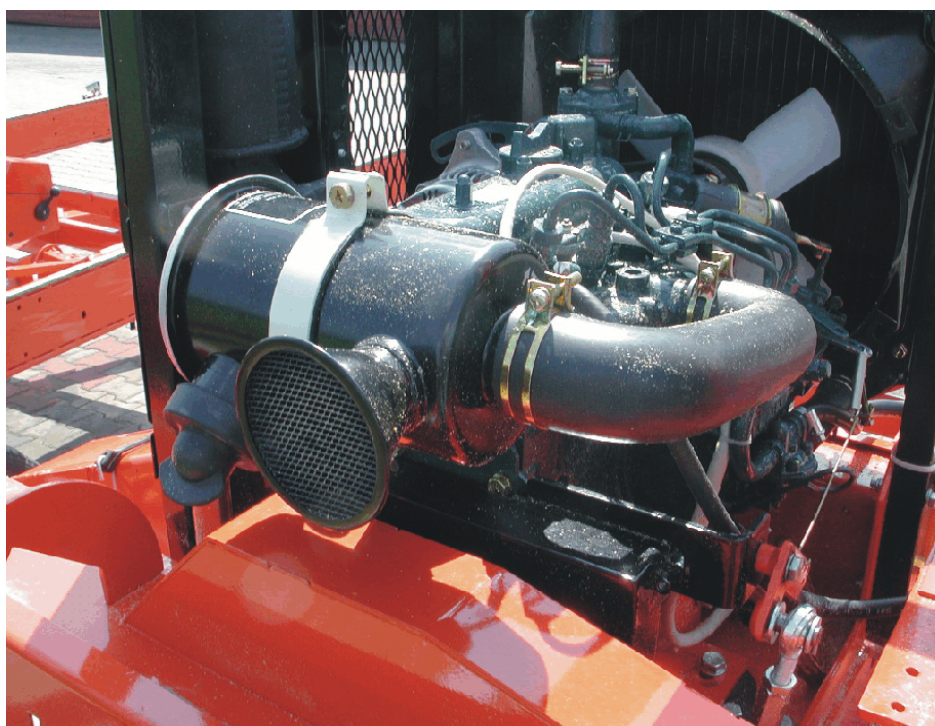

RYS. 3-1



Clean the element every 100 hours of operation. Replace the element every year or every six cleanings. When dry dust adheres to the element, remove it with compressed air (from the inside of the element, rotating the element). The pressure of compressed air must be below .68 MPa.

3.3 Cooling System

8

Check the coolant level every 8 hours of operation.

8

Check the radiator fins every 8 hours of operation.

250

Clean the radiator fins every 250 hours of operation.

1000

Replace the coolant every 1000 hours of operation or every 2 years, whichever comes first. Use a mixture of 50% antifreeze and 50% water.

3.4 Primary Fuel Filter

1500

Patrz rysunek 3-2. Replace the primary fuel filter cartridge every 400 hours of operation. After replacing the filter cartridge, loosen the air bleed screw and operate the fuel pump bail until fuel begins to flow from the valve and is free of air bubbles. Tighten the bleed screw. Inspect the water separator bowl periodically and drain the bowl as required by turning the drain cap counterclockwise as viewed from the bottom.

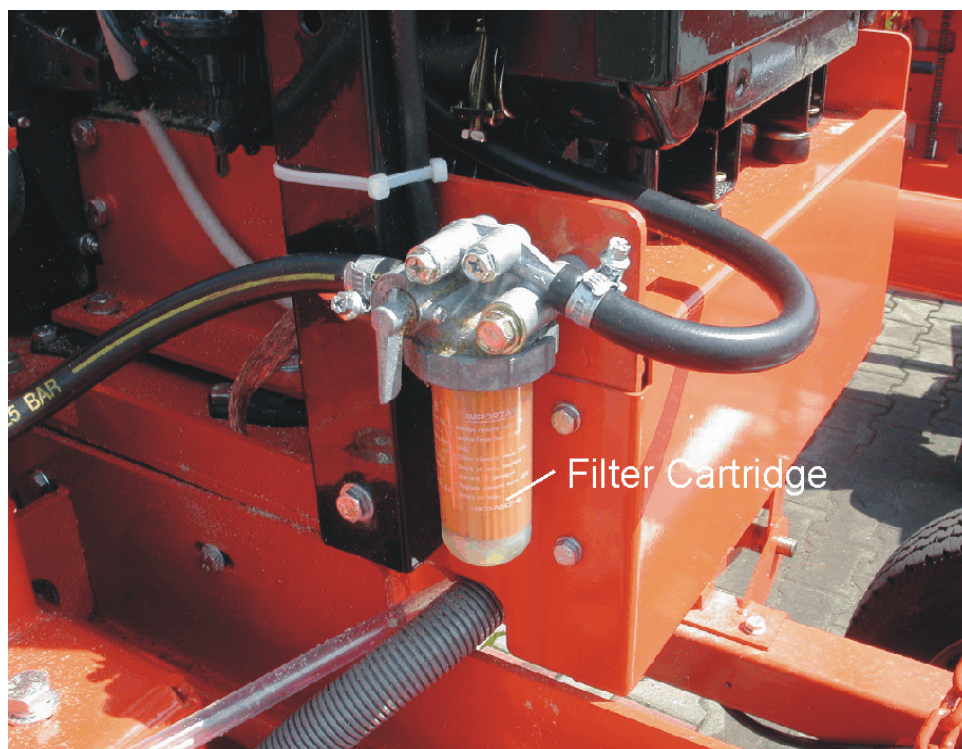
**RYS. 3-2**

3.5 Battery

 Check the battery electrolyte level every 50 hours of operation. See manufacturer's manual for instructions.

 **DANGER!** Batteries expel explosive gases. Keep sparks, flames, burning cigarettes, or other ignition sources away at all times. Always wear safety goggles and a face shield when working near batteries. Failure to do so will cause serious injury.¹

3.6 Alternator Belt

 Check the alternator belt tension every 500 hours. Also check the alternator belt for tension and wear when battery is not charging properly or when the alternator belt is squealing. Adjust as needed.

 Replace the alternator belt every 1000 hours.

1. Battery Council International, copyright 1987

3.7 Drive Belt Adjustment

 **WARNING!** Do not for any reason adjust the engine drive belts or belt support bracket with the engine running. Doing so may result in serious injury.

 Check the drive belt tension after the first 20 hours, and every 50 hours thereafter. When engaged, the drive belt should have 7/16" (11 mm) deflection with a 15 lb. deflection force (67 N).

To adjust drive belt tension:

1. Loosen the drive belt turnbuckle jam nuts. Turn the turnbuckle counterclockwise (as viewed from the top) to tighten the belts, clockwise to loosen the belts.

Patrz rysunek 3-3.

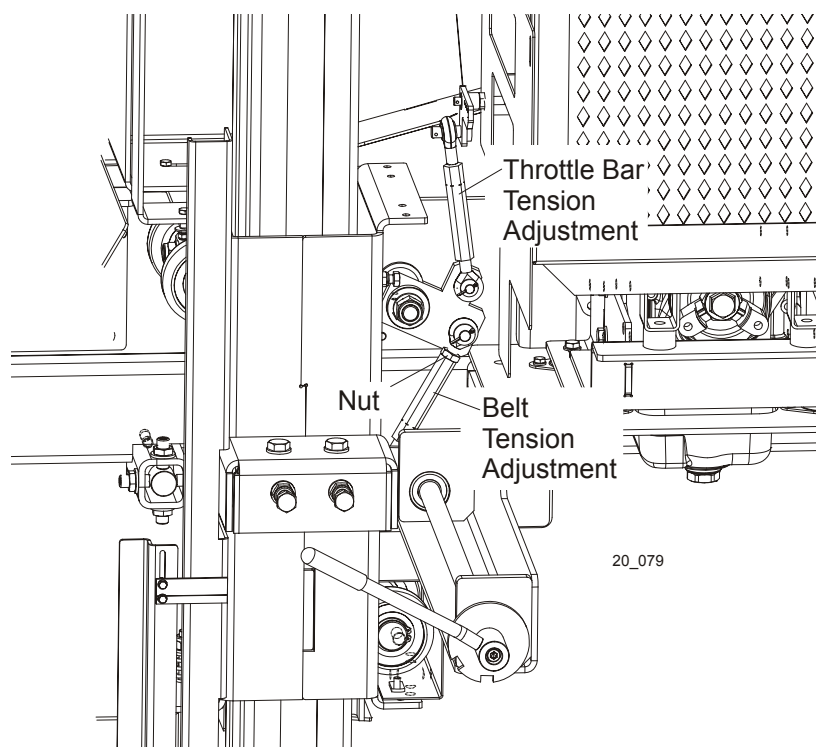

RYS. 3-3

 AR

Periodically check all belts for wear. Replace any damaged or worn belts as needed.

3.8 Clutch Handle Adjustment

After the drive belts and brake strap are properly adjusted, the clutch handle should lock in the down position when the drive belts are engaged. If the clutch handle does not stay locked, adjust the handle turnbuckle.

Patrz rysunek 3-4.

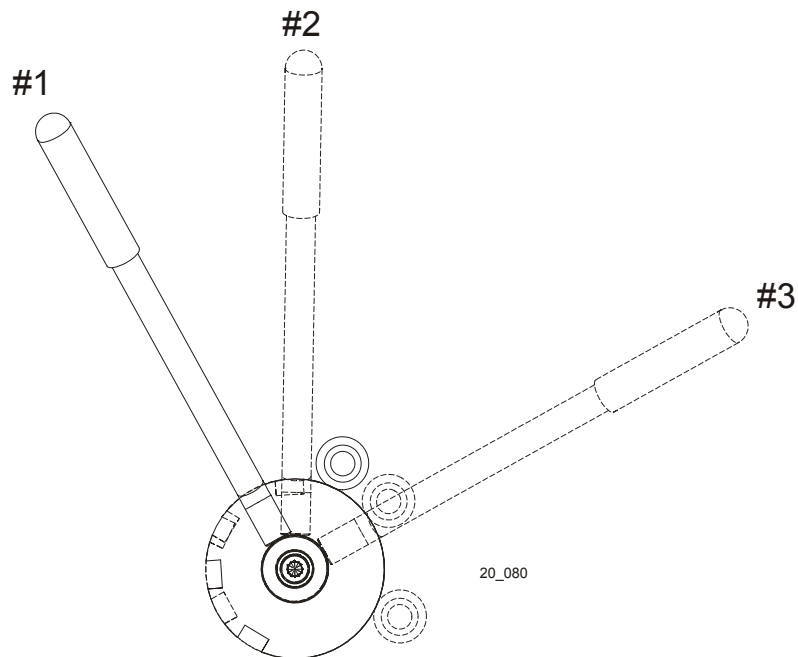

RYS. 3-4

#1 - Brake locked, belt loosened

#2 - Intermediate position (blade replacement): brake unlocked, drive not engaged

#3 - Belt tightened, drive engaged

3.9 Miscellaneous Maintenance

500

Check the valve clearance every 500 hours of operation. Adjust if necessary. See engine manual for further details.

1000

Clean the fuel tank every 1000 hours of operation.

1000

Clean and set the injectors every 1000 hours of operation. See engine manual for more information.

2500

Replace the timing belt every 2500 hours of operation.

2500

Perform a partial overhaul inspection as detailed in the engine manual every 2500 hours of operation.

5000

Perform a complete overhaul inspection as detailed in the engine manual every 5000 hours of operation.

3.10 RPM Adjustments



WARNING! Remove the blade before performing any engine service. Failure to do so may result in serious injury.



Check the RPM with a tachometer after the first 20 hours of operation and every 200 hours thereafter.

Before checking the RPM, make sure belt and brake strap tension are correct (See Saw-mill Maintenance). Also check oil, fuel, and coolant levels.

1. Start the engine to measure the low-end RPM. Let idle for 10 minutes.
2. With the engine at idle, check the low-end RPM. Adjust to 1150-1200. To decrease speed, loosen the idle adjustment bolt. To increase speed, tighten the idle adjustment bolt. Tighten the lock nut to hold the bolt in place.

See Figure 3-5.

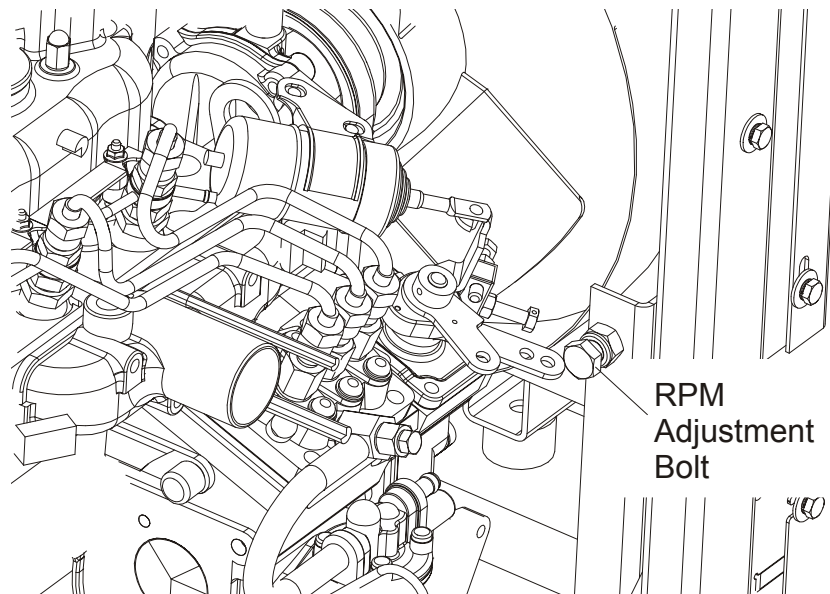

FIG. 3-5



CAUTION! Do not adjust the high-end RPM.

3.11 Storage

Short Term Storage

If storing the engine over 30 days but under 6 months, take the following maintenance steps:

1. Idle the engine for 15 minutes before shutting off.
2. Drain oil and refill crankcase with protection oil MIL-1-644-P9. Run engine at 3/4 full speed for 5-10 minutes.
3. Shut off engine.
4. While the engine is still warm, drain oil. Refill crankcase with standard oil.
5. Remove the fuel filter and drain the fuel tank. Replace gasket if need and reinstall the fuel filter.
6. Carefully clean the radiator fins, heads and fan.
7. Seal all openings with tape.
8. Remove injectors. Poor a spoonful of SAE 30 oil into the cylinders. Manually rotate the cylinders to distribute the oil. Reinstall injectors.
9. Spray SAE 10W oil into exhaust and intake manifolds, rocker arm, valves, tappet, etc. Grease all unpainted parts.
10. Loosen the fan belt.
11. Wrap the engine in a plastic film.
12. Store the engine in a dry place. Keep away from soil and high voltage electric lines.

Long Term Storage

If storing over 6 months follow these additional guidelines:

1. Use a rustproof type MIL-L-21260-P10 grade 2 SAE 30 oil, such as ESSO RUST BAN 623-AGIP, RUSTIA C - SAE 30 for the lubrication and the injection system as well as for moving parts. Let the engine run with rustproof oil and drain any excess.
2. Coat the external unpainted surfaces with an antirust type MIL-C-16173D grade 3 oil, such as ESSO RUST BAN 398-AGIP, RUSTIA 100/F.
3. Replace coolant every 2 years.

Using Engine After Storage

Before using the engine after short or long term storage, perform the following steps:

1. Clean the outside of the engine.
2. Remove protections and covers.
3. Remove antirust oil with an appropriate solvent or degreaser.
4. Remove the injectors, pour a spoonful of standard oil into the cylinders and rotate manually to distribute the oil. Remove the oil pan and drain the protective oil.
5. Check the injectors, valve clearance, belt tension, head tightening, oil filter and air cleaner for proper setting. If the engine has been stored over 6 months, check bearings for corrosion.

SECTION 4 REPLACEMENT PARTS

4.1 How To Use The Parts List

- Use the table of contents or the index to locate the assembly that contains the part you need.
- Go to the appropriate section and locate the part in the illustration.
- Use the number pointing to the part to locate the correct part number and description in the table.
- Parts shown indented under another part are included with that part.
- Parts marked with a diamond (◆) are only available in the assembly listed above the part.

See the sample table below. Sample Part #A01111 includes part F02222-2 and subassembly A03333. Subassembly A03333 includes part S04444-4 and subassembly K05555. The diamond (◆) indicates that S04444-4 is not available except in subassembly A03333. Subassembly K05555 includes parts M06666 and F07777-77. The diamond (◆) indicates M06666 is not available except in subassembly K05555.

4.2 Sample Assembly				
REF	DESCRIPTION (◆ Indicates Parts Available In Assemblies Only)	PART #	QTY.	
	SAMPLE ASSEMBLY, COMPLETE (INCLUDES ALL INDENTED PARTS BELOW)	A01111	1	
1	Sample Part	F02222-22	1	
	Sample Subassembly (Includes All Indented Parts Below)	A03333	1	
2	Sample Part (◆ Indicates Part Is Only Available With A03333)	S04444-4	1	◆
	Sample Subassembly (Includes All Indented Parts Below)	K05555	1	
3	Sample Part (◆ Indicates Part Is Only Available With K05555)	M06666	2	◆
4	Sample Part	F07777-77	1	

To Order Parts:

- From the continental U.S., call our toll-free Parts hotline at **1-800-448-7881**. From Europe call our European Headquarters and Manufacturing Facility in Kolo, Poland at **+48-63-2626000** or **+48-3912-1319**. Have your customer number, vehicle identification number, and part numbers ready when you call.
- From other international locations, contact the Wood-Mizer distributor in your area for parts.

4.3 Fuel Tank Assembly

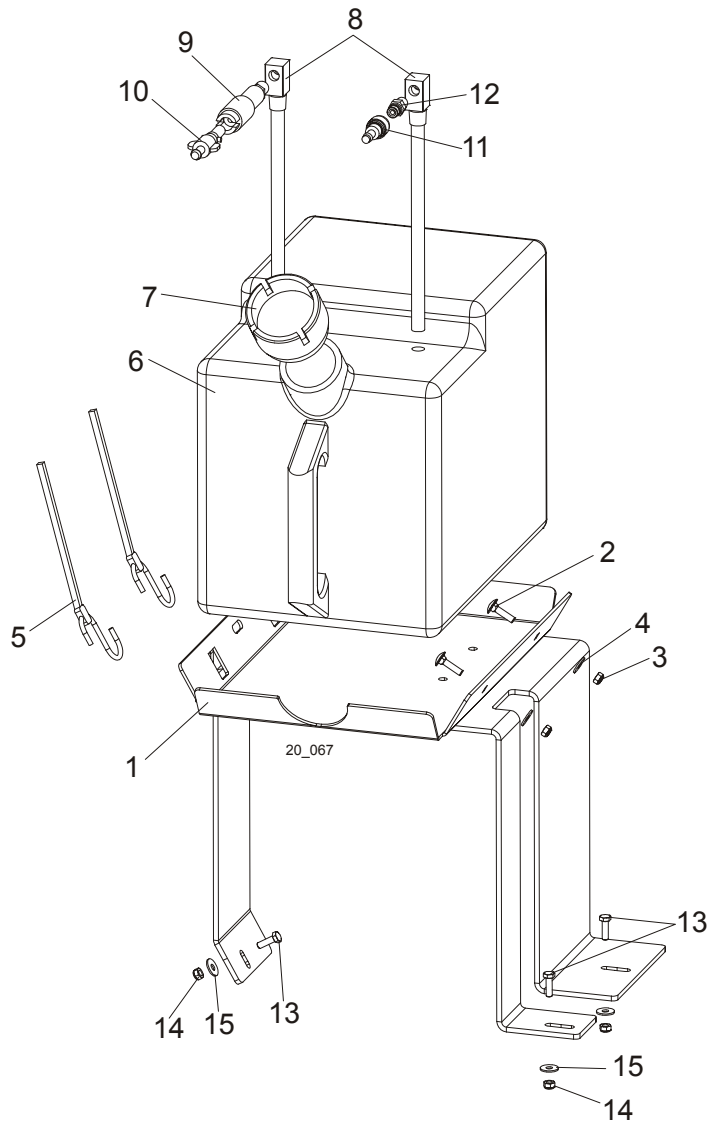

REF	DESCRIPTION (◆ Indicates Parts Available In Assemblies Only)	PART #	QTY.	
	FUEL TANK ASSEMBLY, LT20	091367	1	
1	Tray, LT20 Fuel Tank	091885-1	1	
2	Bolt, M6x25-8.8 Carriage Head Zinc	F81001-20	2	
3	Nut, M6-8-B Hex Nylon Zinc Lock	F81031-2	2	
4	Washer, 6.5 Zinc Flat Special	F81053-11	2	
5	Strap, 20" Rubber (Water Bottle Mount)	P11668	1	
6	Tank, 5-Gallon Diesel Green	P12166	1	
7	Cap, 3 or 5-Gallon Fuel Tank	P09683	1	
8	Pickup, Fuel	P12172	2	
9	Fitting, 1/4" NPT Plastic Male-Female Disconnect	P12175	1	
10	Fitting, 1/4" Barb Plastic Male Disconnect	P12176	1	
11	Fitting, Female Quick Disconnect Barb	015582	1	

4**Replacement Parts***Fuel Tank Assembly*

12	Fitting, 1/4" NPT Male Quick Disconnect	015583	1	
13	BOLT, M6X20-8.8 HEX HEAD FULL THREAD ZINC	F81001-2	3	
14	NUT, M6-8-B HEX NYLON ZINC LOCK	F81031-2	3	
15	WASHER, 6.5 ZINC FLAT SPECIAL	F81053-11	3	

4.4 Engine Mount Assembly

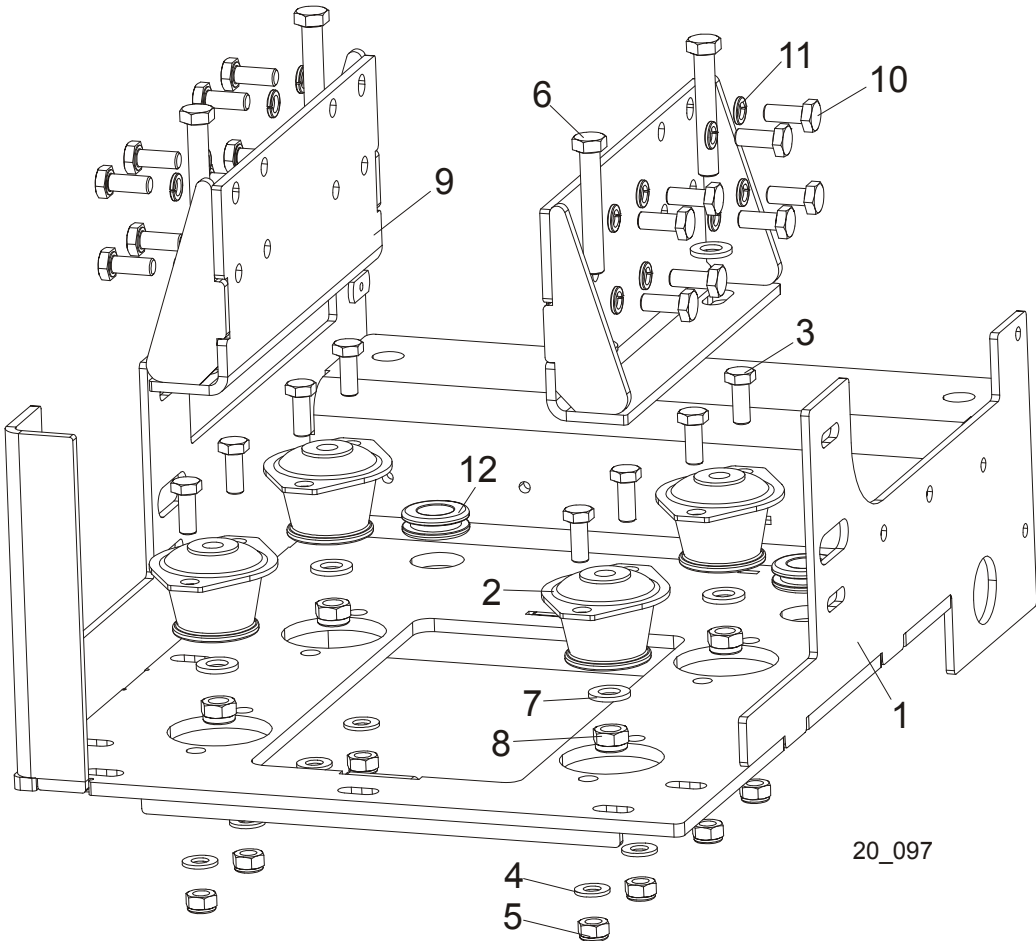

REF	DESCRIPTION (◆ Indicates Parts Available In Assemblies Only)	PART #	QTY.
1	MOUNT WELDMENT, D1005 KUBOTA ENGINE PTD	092345-1	1
2	ABSORBER, #210355,65 SHA SHOCK	091933	4
3	BOLT, M10X25-8.8 HEX HEAD FULL THREAD ZINC	F81003-11	8
4	WASHER, 10.5 ZINC FLAT	F81055-1	8
5	NUT, M10-8-B HEX NYLON ZINC LOCK	F81033-1	8
6	BOLT, M12X75-8.8 HEX HEAD ZINC	F81004-21	4
7	WASHER, 13 ZINC FLAT	F81056-1	8
8	NUT, M12-8 HEX NYLON ZINC LOCK	F81034-2	4
9	BRACKET, D1005 KUBOTA ENGINE MOUNT	092343-1	2
10	BOLT M10-1.5X50MM H/H PART/THR G5 ZINC	F81003-29	16
11	WASHER, M10 SPLIT LOCK ZINC	F81055-2	16
12	GROMMET, 22 MM DIAMETER RUBBER	087400	2

4 Replacement Parts

Engine Assembly

4.5 Engine Assembly

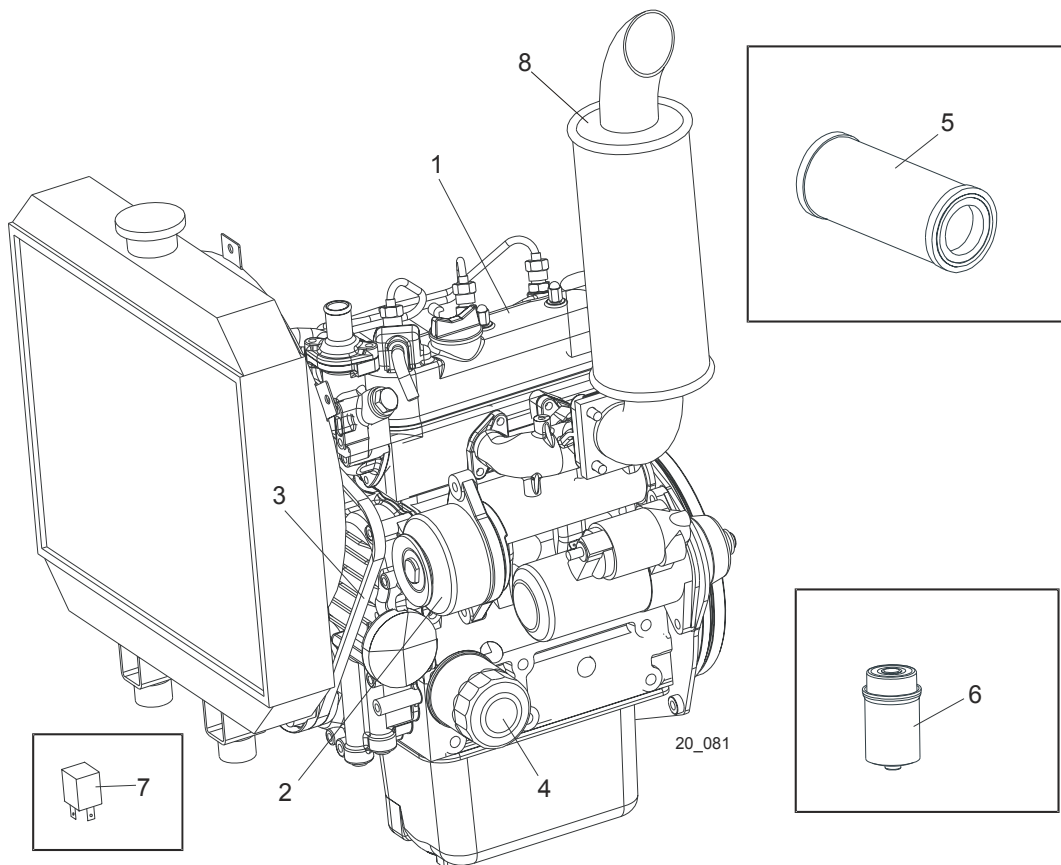

REF	DESCRIPTION (◆ Indicates Parts Available In Assemblies Only)	PART #	QTY.	
1	ENGINE, D1005 KUBOTA	091240	1	◆
2	ALTERNATOR, D722 16241-64010	092206	1	
3	BELT, D22 "KUBOTA" #16282-97010 ALTERNATOR	093599	1	
4	FILTER, D22 "KUBOTA" #16271-32092 OIL	093600	1	
5	ELEMENT, D22 "KUBOTA" #15741-11083 AIR FILTER	093601	1	
6	CARTRIDGE, D22 "KUBOTA" #15221-43080 FUEL FILTER	093602	1	
7	RELAY, #191911261C GLOW PLUG	088143	1	
8	MUFFLER, D1005 KUBOTA ENGINE	092652	1	
	FUEL PRE-FILTER, D1005 KUBOTA ENGINE	092706	1	
	GLOW PLUG 16851-65510	093473	3	

4.6 Drive Assembly

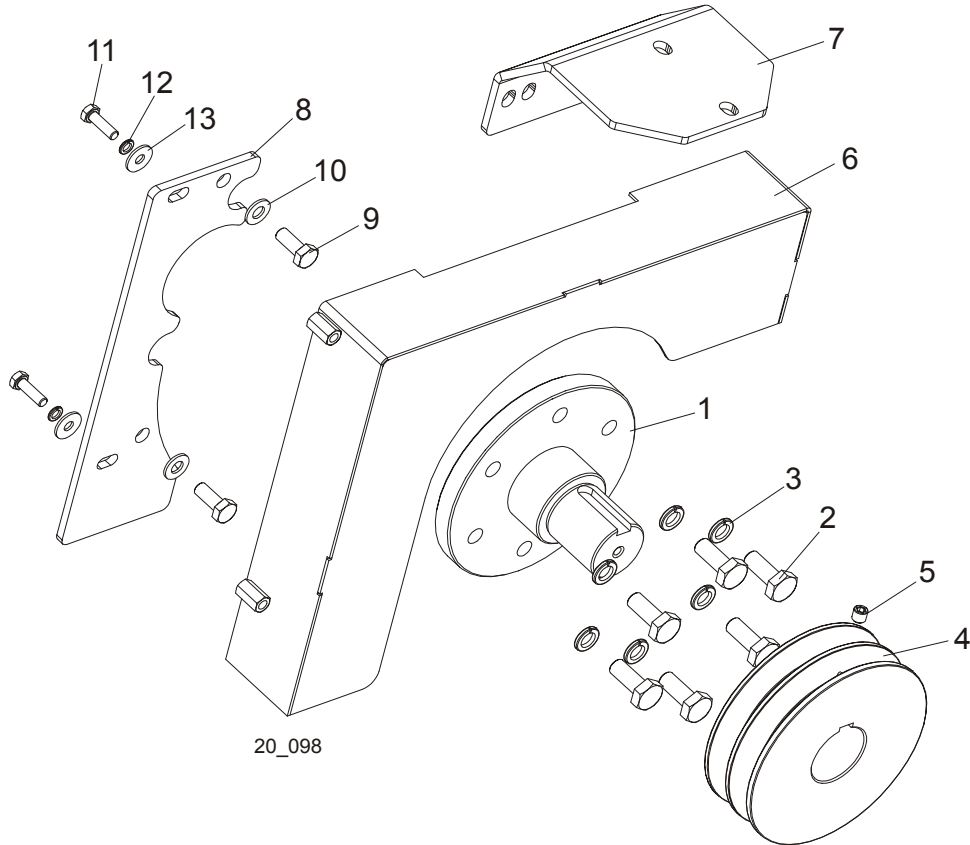

REF	DESCRIPTION (◆ Indicates Parts Available In Assemblies Only)	PART #	QTY.	
1	SHAFT, D1005 KUBOTA ENGINE OUTPUT	092355	1	
2	BOLT M10-1.5X50MM H/H PART/THR G5 ZINC	F81003-29	6	
3	WASHER, M10 SPLIT LOCK ZINC	F81055-2	6	
4	PULLEY, E15 2-GROOVE	091560	1	
5	SCREW, M8X8-33H ZINC HEX SOCKET SET FLAT POINT	F81014-1	1	
6	GUARD, D1005 PULLEY	092364-1	1	
7	BRACKET, AIR CLEANER PTD	092653-1	1	
8	PLATE, PULLEY GUARD MOUNT	092363-1	1	
9	BOLT, M8X20MM,HH,GR 8.8,FULL THRD,ZINC	F81002-1	2	
10	WASHER, M8, FLAT,ZINC	F81054-1	2	
11	BOLT, M6X20-8.8 HEX HEAD FULL THREAD ZINC	F81001-2	3	
12	WASHER, 6.4 ZINC FLAT	F81053-1	3	
13	WASHER, Z 6.1 SPLIT LOCK ZINC	F81053-3	3	
	BELT, 2BX84 "GOOD YEAR"	092697	1	

4 Replacement Parts

Throttle Assembly

4.7 Throttle Assembly

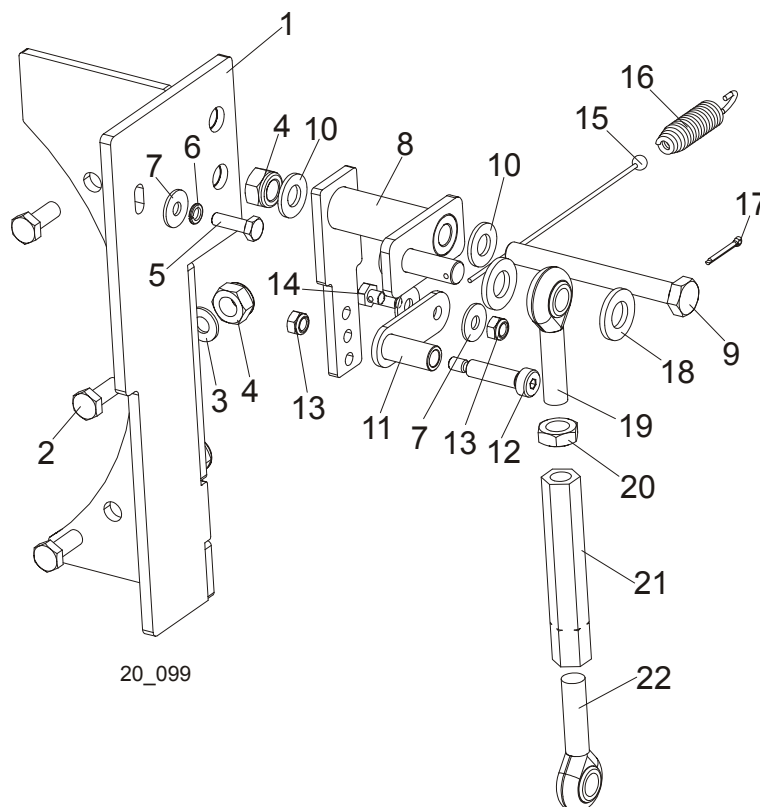

20_099

REF	DESCRIPTION (◆ Indicates Parts Available In Assemblies Only)	PART #	QTY.
1	BRACKET, PIVOT LEVER MOUNT PTD	092362-1	1
2	BOLT, M8X20-5.8 HEX HEAD FULL THREAD ZINC	F81002-1	3
3	WASHER, 8.4 ZINC FLAT	F81054-1	4
4	NUT, M10, NYLON HEX ZINC LOCK	F81033-1	1
5	BOLT, M6X20MM, HH, FULL THREAD, ZINC	F81001-2	1
6	WASHER, M6 SPLIT LOCK ZINC	F81053-3	1
7	WASHER, M6, FLAT, ZINC	F81053-11	3
8	LEVER WELDMENT, THROTTLE PIVOT PTD	092662-1	1
9	BOLT, M10X95MM HH FULL THRD GR5.8 ZINC	F81003-71	1
10	WASHER, FLAT, M10, ZINC	F81055-1	2
	BAR, THROTTLE COMPLETE	092703	1
11	Bar, Throttle	092702-1	1
12	Bolt, 8/M6x30-12.9 ISO-7379	F81001-18	1
13	Nut, M6, Hex, Nylon Lock Zinc	F81031-2	1
14	Bolt, Throttle Cable Clamp Zinc	088120-1	1
15	Cable Kit, Kubota D1005 Throttle Repl	092695	1
16	Spring 40x9x2,2 Extension	089451	1
17	COTTER, SR 4MM PIN	F81043-1	1
18	WASHER, M12, FLAT, ZINC	F81056-1	2
19	BOLT, M10X1,25X25-8.8-A HEX HEAD FULL THREAD ZINC	F81003-2	1

20	ROD END, 7/16-20 LEFT-HAND MALE	P11578	1	
21	NUT, 7/16-20 ZINC	F05010-38	1	
22	TURNBUCKLE, 3 3/4 CLUTCH	S12262	1	
23	ROD END, 7/16-20 RIGHT-HAND MALE	P11579	1	

4 Replacement Parts

Radiator Assembly

4.8 Radiator Assembly

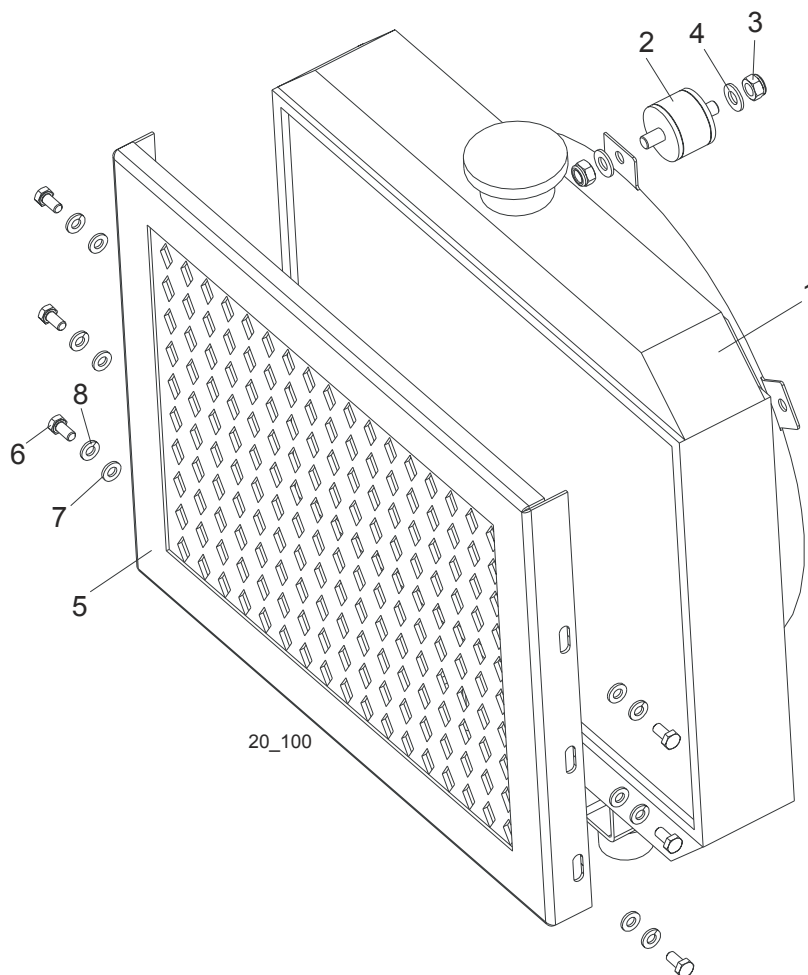

REF	DESCRIPTION (◆ Indicates Parts Available In Assemblies Only)	PART #	QTY.	
1	RADIATOR, D722 KUBOTA ENGINE	N/D	1	
2	ABSORBER, M8 SHOCK	088183	1	
3	NUT, M8-8-B HEX NYLON ZINC LOCK	F81032-2	2	
4	WASHER, 8.4 ZINC FLAT	F81054-1	2	
5	GUARD, D1005 RADIATOR	092386-1	1	
6	BOLT, M6X20MM, HH, FULL THREAD, ZINC	F81001-2	6	
7	WASHER, M6, FLAT,ZINC	F81053-11	6	
8	WASHER, Z 6.1 SPLIT LOCK ZINC	F81053-3	4	

SECTION 5 ELECTRICAL INFORMATION

5.1 Electrical Wiring Diagram, D22 Engine

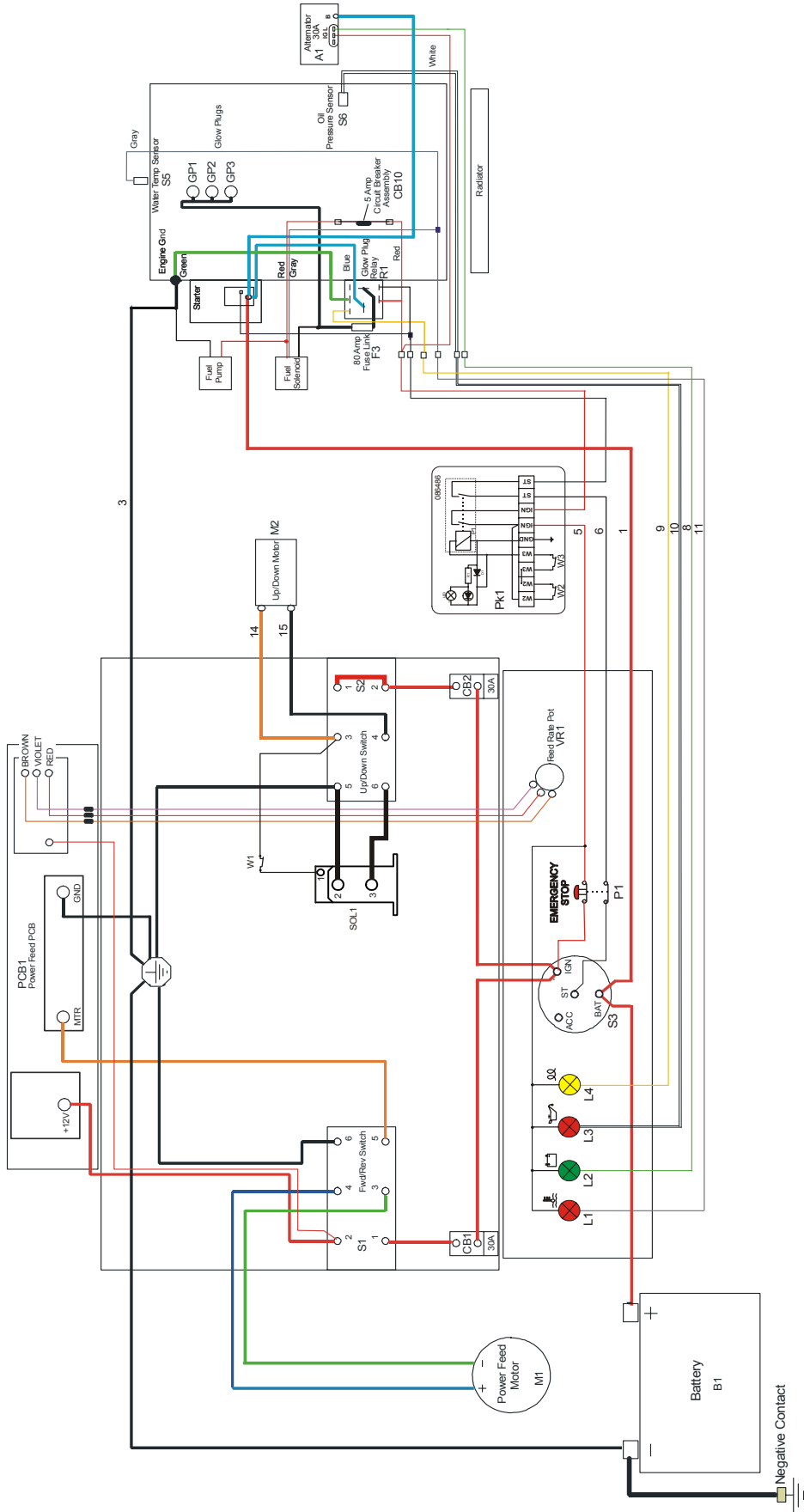

FIG. 6-0 D22 ELECTRICAL WIRING DIAGRAM

6.2 Electrical Components, DP22-20S

Item	Manufacturer	WM Part #	Description
S1	SCHNEIDER ELECTRIC	E20439	Switch, US1992 Pwr/Feed (Service Package)
S2	SCHNEIDER ELECTRIC	E20438	Switch, 1992GS Pwr/Feed (Service Package)
B1	BANNER	090999	Battery, 12V 50Ah ENERGY BULL BA50
CB1	-	024246	Breaker, 30 Amp Manual Reset Panel Mount
CB2	-	021256	Breaker, 50 Amp Manual Reset Panel Mount
PCB1	WMP	024396-1	Module, Power Feed Control
S3	-	P04350	Key Switch
SOL1	-	P10449	Solenoid, 120-943 12V DC
SOL2	KUBOTA	-	Solenoid, Engine Shut-Off
PK1	-	086486	Relay, Safety Key Switches
VR1	-	E20519	Potentiometer, 1K Feed Rate
M1,M2	-	P04140	Motor, 12V 0.5HP Up/Down
P1	SCHNEIDER ELECTRIC	086556	Switch, XB4 BS542 Emergency Stop
L1, L3	-	090998	Control Light, KLA-RS-10-2
L2	-	091051	Control Light, KLA-GS-10-2
L4	-	091456	Control Light, KLA-RS-10-2
W2	HONEYWELL	087650	Limit Switch, GKMC03W2
W3	HONEYWELL	091742	Limit Switch, EVN2000A (Saw Head Loading Position)
W1	HONEYWELL	089816	Limit Switch, EVN2000C (Maximum Saw Head Height)
R1	BOSCH	088143	Relay, #191911261C Glow Plug

TABLE 6-1