

D22 Engine

Safety, Operation, Maintenance & Parts Manual

LT20

rev. E3.05



Safety is our #1 concern! Read and understand all safety information and instructions before operating, setting up or maintaining this machine.

Form #618

Table of Contents

Section-Page

SECTION 1	SAFETY & GENERAL INFORMATION	1-1
1.1	Refueling	1-1
1.2	Engine Operation.....	1-2
1.3	Battery Handling	1-4
1.4	General Information	1-5
1.5	Engine Specifications	1-6
SECTION 2	OPERATION	2-1
2.1	Starting the Engine	2-1
SECTION 3	MAINTENANCE	3-1
3.1	Engine Oil & Filter.....	3-2
3.2	Air Cleaner	3-4
3.3	Cooling System	3-5
3.4	Primary Fuel Filter	3-6
3.5	Battery	3-7
3.6	Alternator Belt Adjustment	3-8
3.7	Drive Belt Adjustment.....	3-10
3.8	Clutch Handle Adjustment	3-11
3.9	Miscellaneous Maintenance	3-12
3.10	RPM Adjustments	3-13
3.11	Storage.....	3-14
SECTION 4	REPLACEMENT PARTS	4-1
4.1	How To Use The Parts List	4-1
4.2	Sample Assembly	4-1
4.3	Fuel Tank Assembly	4-2
4.4	Water Bottle	4-4
4.5	Belt Tensioner	4-5
4.6	Engine Mount Assembly	4-6
4.7	Engine Assembly.....	4-7
4.8	Alternator Assembly	4-9
4.9	Drive Assembly	4-11
4.10	Throttle Assembly	4-12
4.11	Radiator Assembly & D22 Engine Guards	4-14

SECTION 1 SAFETY & GENERAL INFORMATION



IMPORTANT! This manual is provided as a supplement to the equipment manufacturer's manuals. This manual takes into account the specific use of engines on the Wood-Mizer sawmill. Only safety, maintenance, and operating procedures that are not provided by the manufacturer are supplied in this manual. Refer to the manufacturer's manual before attempting to operate this equipment.



This symbol calls your attention to instructions concerning your personal safety. Be sure to observe and follow these instructions. This symbol accompanies a signal word. The word **DANGER** indicates an imminently hazardous situation which, if not avoided, will result in death or serious injury. **WARNING** suggests a potentially hazardous situation which, if not avoided, could result in death or serious injury. **CAUTION** refers to potentially hazardous situations which, if not avoided, may result in minor or moderate injury to persons or equipment. Read all safety instructions before operating this equipment and observe all safety warnings!

1.1 Refueling



DANGER! Due to the flammable nature of fuel and oil, never smoke, weld, grind or allow sparks near your engine or storage tanks, especially during times of fueling.

DANGER! Never allow fuel to spill on a hot engine during fueling operations or otherwise. The hot temperature of your engine could induce a fire or explosion.



WARNING! Store gasoline away from sawdust and other flammable materials. Failure to do so may result in serious injury.

1.2 Engine Operation



DANGER! Operate your engine/machine only in well ventilated areas. The exhaust gases of your engine can cause nausea, delirium and potentially death unless adequate ventilation is present.

DANGER! Never operate an engine with a fuel or oil leak. The leaking fuel or oil could potentially come in contact with hot surfaces and ignite into flames.

DANGER! Engine components can become very hot during operation. Avoid contact with any part of a hot engine. The exhaust components of your engine are especially hot during and following operation. Contact with hot engine components can cause serious burns. Therefore, never touch or perform service functions on a hot engine. Allow the engine to cool sufficiently before beginning any service function.

DANGER! Always be aware of and take proper protective measures against rotating shafts, pulleys, fans, etc. Always stay a safe distance from rotating members and make sure that loose clothing or long hair does not engage rotating members resulting in possible injury.

DANGER! Always be sure the blade is disengaged and all persons are out of the path of the blade before starting the engine or motor. Failure to do so will result in serious injury.



WARNING! Do not for any reason adjust the engine drive belts or belt support bracket with the engine running. Doing so may result in serious injury.

WARNING! Do not operate engine without proper and operational spark arrester/muffler. Sparks emitted from the engine exhaust could ignite surrounding materials, causing serious injury or death.

WARNING! Remove the blade before performing any engine service. Failure to do so may result in serious injury.



WARNING! Always disconnect the machine battery cables before performing service functions. Diesel engines by default require diesel fuel and lubricating oil for operation. Both diesel fuel and lubricating oil are flammable. Disconnection of the battery cables will reduce the possibility of sparks with potentially resultant fires or explosions.



WARNING! Be sure the power feed switch is in the neutral position before turning the key switch to the on (#1) or accessory (#3) position. This prevents accidental carriage movement, which may cause serious injury or death.

WARNING! Always wear proper and necessary safety equipment when performing service functions. Proper safety equipment includes eye protection, breathing protection, hand protection and foot protection.

WARNING! The engine exhaust from this product contains chemicals known to the State of California to cause cancer, birth defects or other reproductive harm.



IMPORTANT! Always dispose of coolant, oil, fuel, oil filters and fuel filters in a responsible manner and in conformance with local, state and federal regulations.



CAUTION! Do not crank starter for more than 7 seconds at one time during starting attempts. Damage to the engine may result.

CAUTION! During the initial 50 hours, do not exceed 70% of the maximum rated power. Damage to the engine may result.

CAUTION! Do not adjust the high-end RPM above 3200. Doing so may cause damage to the engine.

1.3 Battery Handling



DANGER! Batteries expel explosive gases. Keep sparks, flames, burning cigarettes, or other ignition sources away at all times. Always wear safety goggles and a face shield when working near batteries. Failure to do so will cause serious injury.¹



WARNING! Charge the battery in a well ventilated area. Do not attempt to charge a frozen battery.

WARNING! Use extreme care to avoid spilling or splashing electrolyte (which is dilute sulfuric acid) as it can destroy clothing and burn the skin. If electrolyte is spilled or splashed on clothing or the body, it should be neutralized immediately and then rinsed with clean water. A solution of baking soda, or household ammonia, and water may be used as a neutralizer.

Electrolyte splashed into the eyes is extremely dangerous. If this should happen, force the eye open and flood it with cool, clean water for approximately fifteen minutes. A doctor should be called immediately when the accident occurs and “on-the-spot” medical attention given if possible. If a doctor cannot come to the scene of the accident immediately, follow his instructions concerning actions to take. Do not add eye drops or other medication unless advised to do so by the doctor. Do not place a battery or acid within the reach of children. If acid (electrolyte) is taken internally drink large quantities of water or milk. Follow with milk of magnesia, beaten egg or vegetable oil. Call a physician immediately.

If electrolyte is spilled or splashed on any surface of the machine, it should be neutralized and rinsed with clean water.¹

1. Battery Council International, copyright 1987

1 Safety & General Information

General Information

1.4 General Information



IMPORTANT! Read the engine manual for instructions and safety precautions before operating the engine.

See **Figure 1-1**. The main components of the diesel engine are shown.

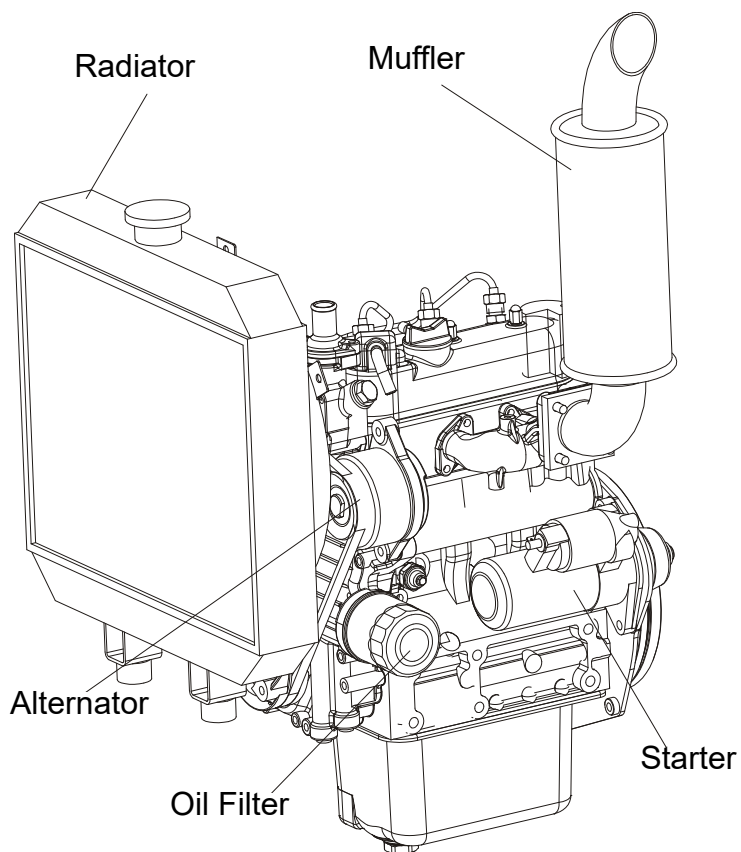

FIG. 1-1

1.5 Engine Specifications

	D1105-E4
Type	Vertical, water-cooled, 4-cycle diesel engine
Number of cylinders	3
Bore and stroke mm	78 x 78,4
Total displacement cm³	1123
Power H.P. (SAEJ 1349) [HP/min⁻¹ (rpm)]	23,9/3000
Peak Torque (Nm)	68,3
Dry Weight kg [lbs.]	93 [205]
Oil Capacity (w/filter)	5,1L

SECTION 2 OPERATION

2.1 Starting the Engine

Engine Control Lights

See Figure 2-1. See the manufacturer's engine manual for troubleshooting tips.



NOTE: Indicator also lights up when engine is started and remains lit until engine initially reaches approximately 1300 RPM.



Engine Temperature Indicator: Lights up if the engine is overheating.



Oil Indicator



Glow Plug Indicator

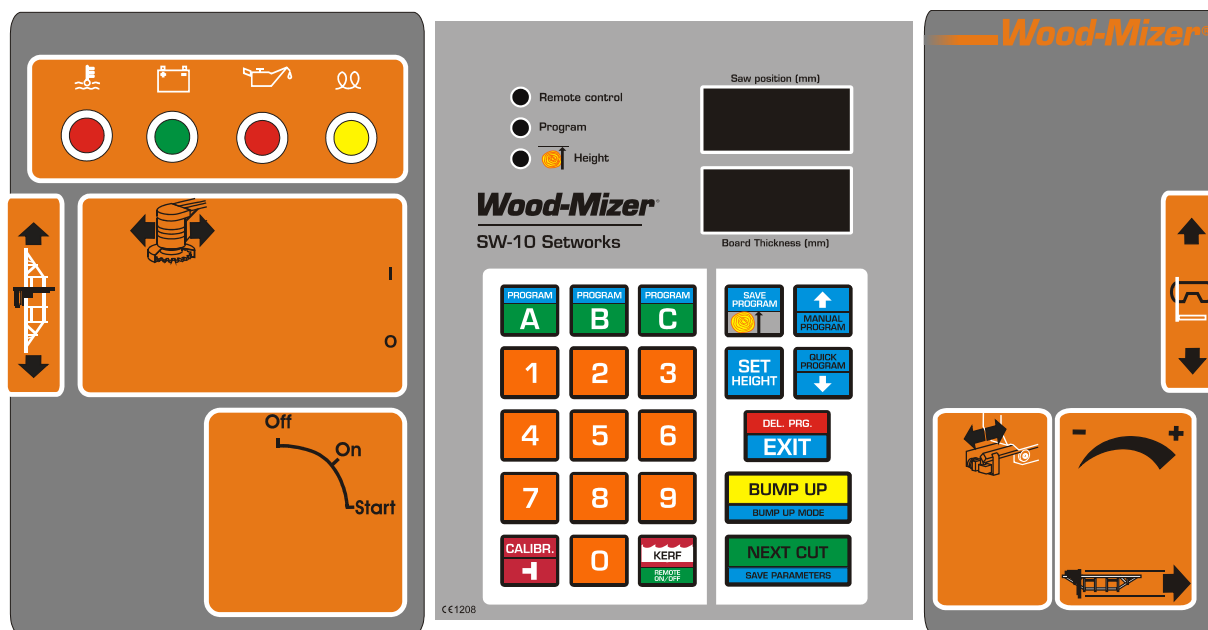

FIG. 2-1

NOTE: The glow plug indicator will go out after the engine is started.



CAUTION! Avoid leaving the key in the #1 position for more than 30 seconds while the engine is not running. Doing so will drain the sawmill battery which may reduce its service life.

Engine Start



DANGER! Always be sure the blade is disengaged and all persons are out of the path of the blade before starting the engine. Failure to do so will result in serious injury.



WARNING! Be sure the power feed switch is in the neutral position before turning the key switch to the on (#1) or accessory (#3) position. This prevents accidental carriage movement which may cause serious injury or death.



CAUTION! Should the glow indicator redden too quickly or too slowly, immediately ask your KUBOTA dealer to check and repair it.



CAUTION! If the engine does not catch or start within 10 seconds after turning the starter switch to the START position, wait another 30 seconds and then try to start the engine again. Do not crank starter for more than 20 seconds at one time during starting attempts.

1. See the engine manufacturer's manual for lubricating oil recommendations for specific temperature ranges.
2. Use #2 or better quality diesel fuel for above freezing starting. Use a #1 quality diesel fuel for below freezing starting.
3. Turn the key switch on the control panel to the ON (#1) position.
4. Turn the key switch to the start (#2) position and release.

Engine Shutoff

Turn the key switch to the OFF (#0) position.

Operator Presence Function

After engaging the blade drive, the power feed must be activated within 10 seconds. Otherwise the engine will be stopped.

SECTION 3 MAINTENANCE



IMPORTANT! This manual only provides information about additional procedures or procedures to be performed at different time intervals than found in the engine manufacturer's manuals. Refer to the manufacturer's manual for complete maintenance instructions.



DANGER! Engine components can become very hot during operation. Avoid contact with any part of a hot engine. The exhaust components of your engine are especially hot during and following operation. Contact with hot engine components can cause serious burns. Therefore, never touch or perform service functions on a hot engine. Allow the engine to cool sufficiently before beginning any service function.



WARNING! Remove the blade before performing any engine service. Failure to do so may result in serious injury.

WARNING! Always disconnect the machine battery cables before performing service functions. Diesel engines by default require diesel fuel and lubricating oil for operation. Both diesel fuel and lubricating oil are flammable. Disconnection of the battery cables will reduce the possibility of sparks with potentially resultant fires or explosions.

WARNING! Always wear proper and necessary safety equipment when performing service functions. Proper safety equipment includes eye protection, breathing protection, hand protection and foot protection.



This symbol identifies the interval (hours of operation) at which each maintenance procedure should be performed. "AR" signifies maintenance procedures which should be performed as required.

3.1 Engine Oil & Filter

See Figure 3-1. The following chart details lubricating oil viscosity as a function of ambient temperature. Select the lubricating oil viscosity based upon the prevailing temperature range expected. If your application will be subject to large ambient temperature ranges during a given oil change interval, select the lubricating oil viscosity based upon the highest temperature expected. Should the prevailing ambient temperatures change during a given oil service period interval, and the lubricating oil within the engine is reflective of a lower temperature range, the lubricating oil should be changed to reflect the prevailing temperature.

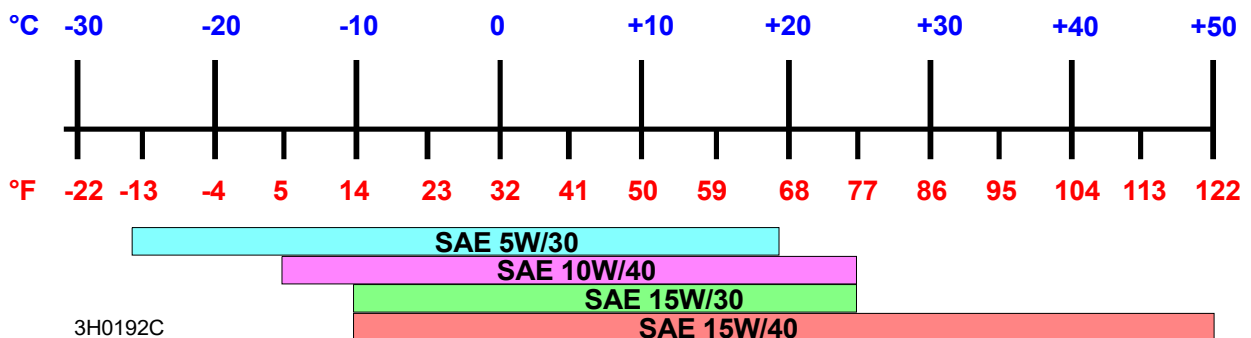

FIG. 3-1

Kubota recommends that only API (American Petroleum Institute) grades 'CD' or higher be used within Kubota diesel engines. In addition to the API rating, lubricating oils should also meet or exceed MIL-L-2104D. Without respect to brand name, lubricating oil meeting API grade 'CD' and sourced from a reputable supplier are acceptable for use within Kubota diesel engines.

See the table below for recommended types of engine oil depending on ambient temperature ranges.

Above 25°C	SAE30 or SAE10W-30 SAE10W-40
0 - 25°C	SAE20 or SAE10W-30 SAE10W-40
Less Than 0°C	SAE10W or SAE10W-30 SAE10W-40

TABLE 3-1

The use of "SEMI-SYNTHETIC" lubricating oils meeting the grade and viscosity guidelines presented above is acceptable and may reduce engine wear rates due to the superior characteristics of the "SEMI-SYNTHETIC" oil with respect to mineral based engine lubricating oils.

Kubota does not recommend the use of ANY oil additive other than those included within the respective manufacturer oil blends. Under no circumstances should oil additives claiming “teflon”, “molecular adhesion”, low wear rates etc. be added. These aftermarket oil additives may actually break down the recommended lubricating oil chemical properties resulting in accelerated engine wear.

When operating in temperatures below those specified in the chart, [see Section 2.1](#).

Oil capacity (including oil filter) is 3.8 liters.



Check the oil level every 8 hours of operation. Add oil as necessary.



Change the oil and replace the oil filter after the first 50 hours of operation. Change the oil every 100 hours and replace the oil filter every 200 hours thereafter.



IMPORTANT NOTE! Before reinstalling the clean oil filter, wipe all dirt and oil deposits from the oil filter receptacle.

3.2 Air Cleaner

Since the air cleaner used on this engine is a dry type, do not oil it. Wipe the inside of the cleaner with a rag if it is dirty or wet. Avoid touching the element except while cleaning.

Open the rubber valve and clean the air intake steel mesh once a week under normal conditions or daily under dusty conditions to remove any large particles of dust and dirt.



FIG. 3-1



Clean the element every 100 hours of operation. Replace the element every year or every six cleanings. When dry dust adheres to the element, remove it with compressed air (from the inside of the element, rotating the element). The pressure of compressed air must be below 0.68 MPa.

3.3 Cooling System

8

Clean the radiator fins every 8 hours of operation. Spray the radiator with water from a hose or compressed air to clean sawdust from the radiator fins. Do not use a pressure sprayer.



CAUTION! Failure to keep the radiator fins clear of sawdust and/or dirt may cause the engine to overheat resulting in damage to the engine.



CAUTION! Do not spray the radiator with water when the engine is hot.



CAUTION! Do not open the radiator cap or reservoir cap when the engine is hot.

8

Every 8 hours of operation check the coolant level on the coolant reservoir. When engine is cold the coolant level should be above the LOW level.

For the aluminium radiator use only glycol solution (1l. of glycol concentrate for 1l. of distilled water).

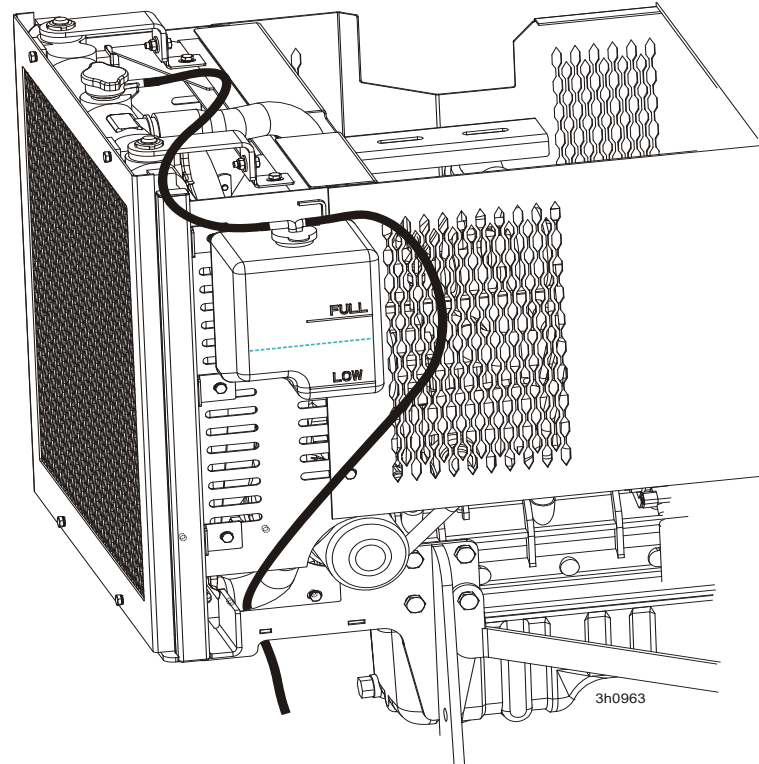

FIG. 3-1

3.4 Primary Fuel Filter

▶ **1500** See **Figure 3-2**. Replace the primary fuel filter cartridge every 400 hours of operation. After replacing the filter cartridge, loosen the air bleed screw and operate the fuel pump bail until fuel begins to flow from the valve and is free of air bubbles. Tighten the bleed screw. Inspect the water separator bowl periodically and drain the bowl as required by turning the drain cap counterclockwise as viewed from the bottom.

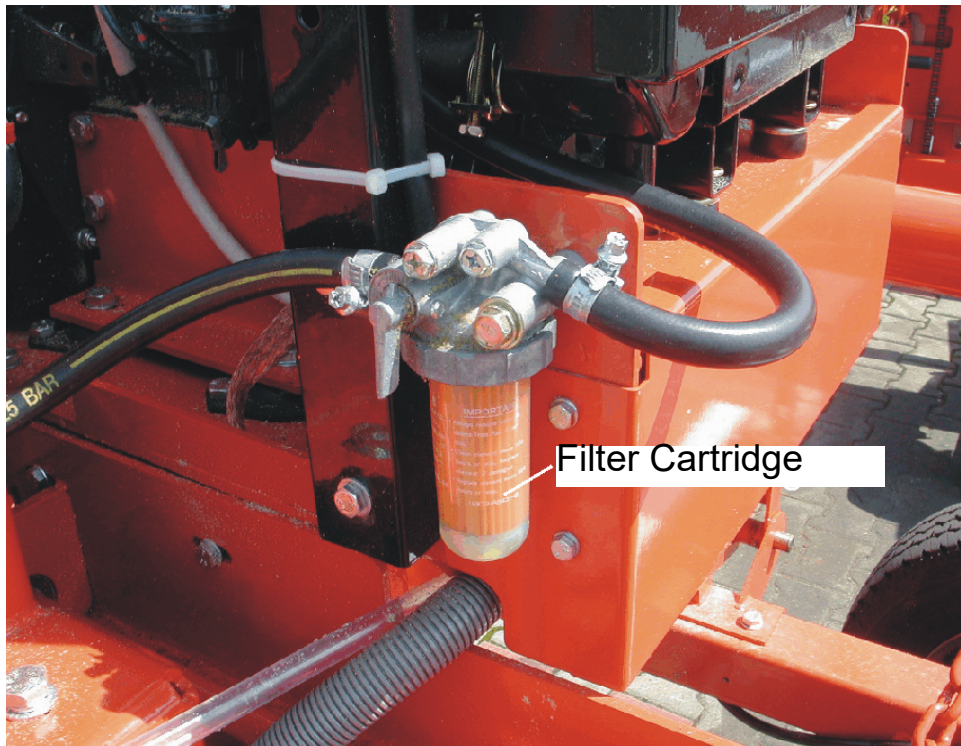

FIG. 3-2

3.5 Battery



Check the battery electrolyte level every 50 hours of operation. See manufacturer's manual for instructions.



DANGER! Batteries expel explosive gases. Keep sparks, flames, burning cigarettes, or other ignition sources away at all times. Always wear safety goggles and a face shield when working near batteries. Failure to do so will cause serious injury.¹

1. Battery Council International, copyright 1987

3.6 Alternator Belt Adjustment

500 Check the alternator belt tension every 500 hours. Also check the alternator belt for tension and wear when battery is not charging properly or when the alternator belt is squealing. Adjust as needed.

1000 Replace the alternator belt every 1000 hours.

Alternator Belt Adjustment Procedure:

1. Turn the key switch to OFF (#0) and remove the key.
2. Unscrew the M8 screws (A), and remove the alternator cover (B).

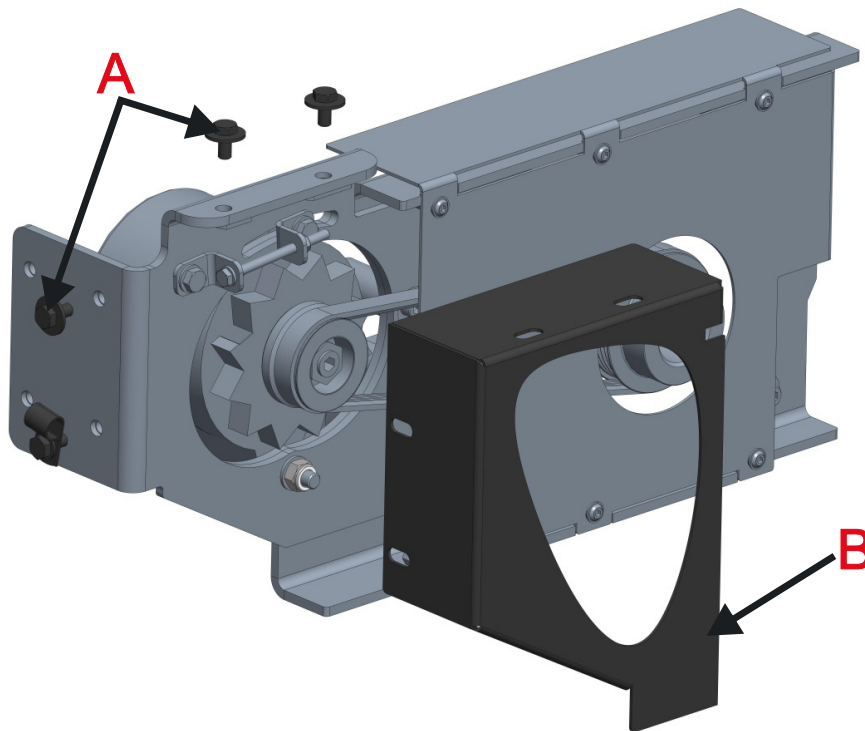
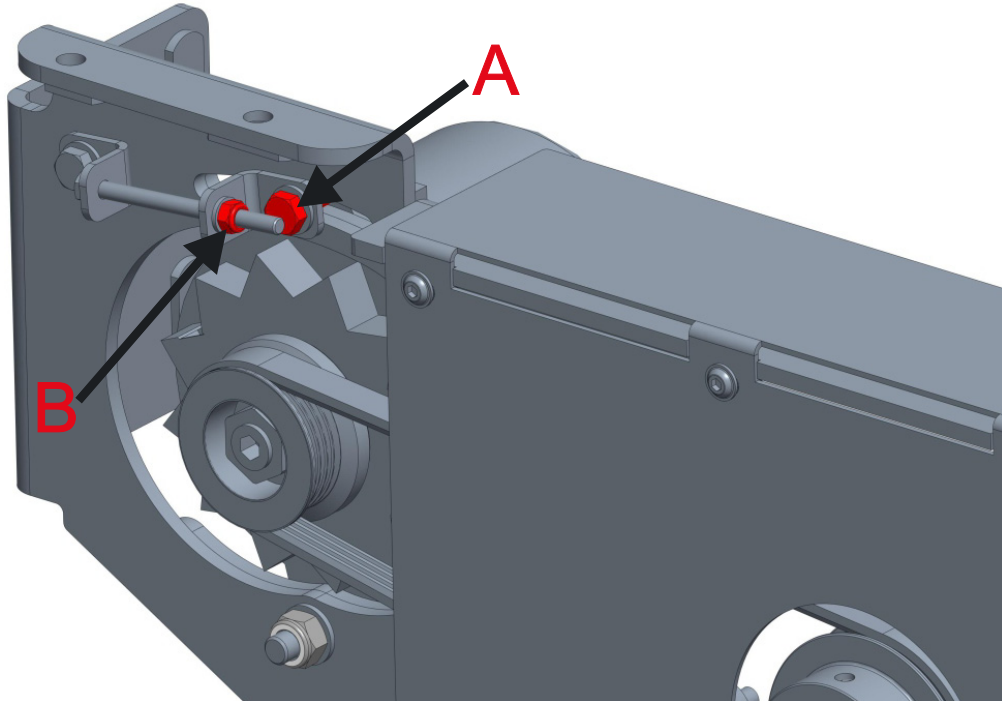

FIG. 3-2

3**Maintenance***Alternator Belt Adjustment*

3. Loosen the M8 bolt (A). Tension the alternator belt by tightening the M6 nut (B).

**FIG. 3-2**

4. Check the alternator belt tension.
5. Tighten the previously loosened M8 bolt.
6. Mount the previously removed alternator cover.

3.7 Drive Belt Adjustment

 **WARNING!** Do not for any reason adjust the engine drive belts or belt support bracket with the engine running. Doing so may result in serious injury.

 Check the drive belt tension after the first 20 hours, and every 50 hours thereafter. When engaged, the drive belt should have 7/16" (11 mm) deflection with a 15 lb. deflection force (67 N).

To adjust drive belt tension:

1. Loosen the drive belt turnbuckle jam nuts. Turn the turnbuckle counterclockwise (as viewed from the top) to tighten the belts, clockwise to loosen the belts.

See Figure 3-3.

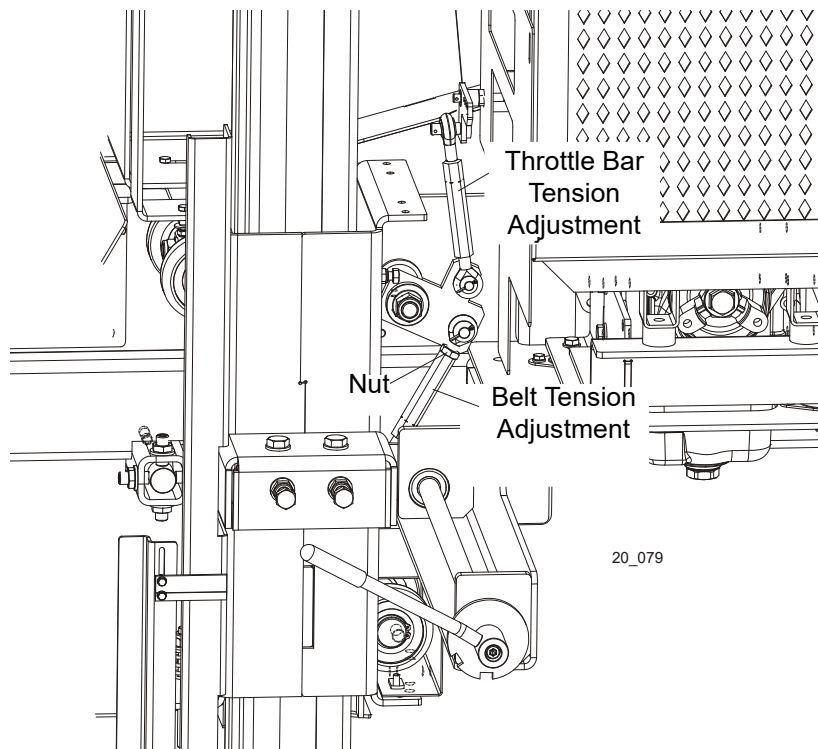

FIG. 3-3

 Periodically check all belts for wear. Replace any damaged or worn belts as needed.

3.8 Clutch Handle Adjustment

After the drive belts and brake strap are properly adjusted, the clutch handle should lock in the down position when the drive belts are engaged. If the clutch handle does not stay locked, adjust the handle turnbuckle.

See Figure 3-4.

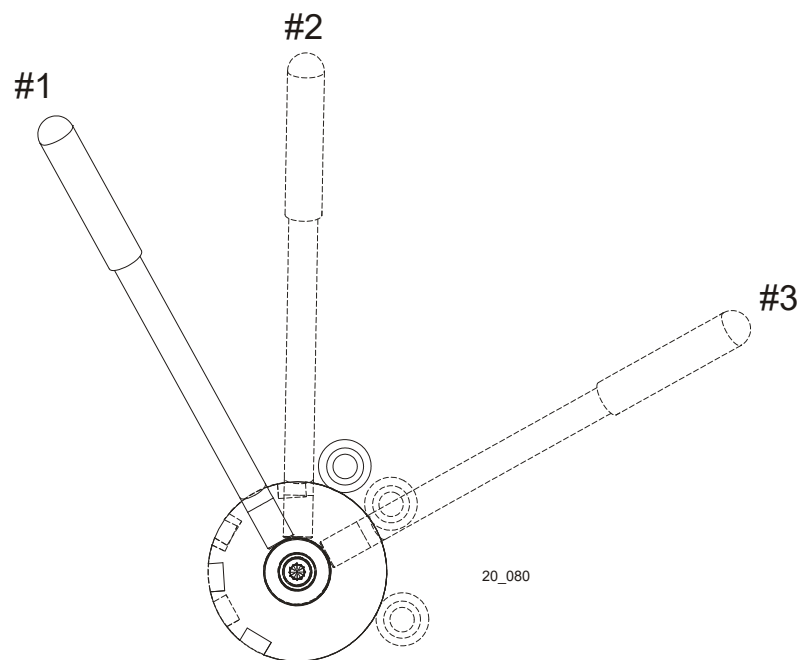







FIG. 3-4

#1 - Brake locked, belt loosened

#2 - Intermediate position (blade replacement): brake unlocked, drive not engaged

#3 - Belt tightened, drive engaged

3.9 Miscellaneous Maintenance

-  Check the valve clearance every 500 hours of operation. Adjust if necessary. See engine manual for further details.
-  Clean the fuel tank every 1000 hours of operation.
-  Clean and set the injectors every 1000 hours of operation. See engine manual for more information.
-  Replace the timing belt every 2500 hours of operation.
-  Perform a partial overhaul inspection as detailed in the engine manual every 2500 hours of operation.
-  Perform a complete overhaul inspection as detailed in the engine manual every 5000 hours of operation.

3.10 RPM Adjustments

 **WARNING!** Remove the blade before performing any engine service. Failure to do so may result in serious injury.

 Check the RPM with a tachometer after the first 20 hours of operation and every 200 hours thereafter.

Before checking the RPM, make sure belt and brake strap tension are correct (See Sawmill Maintenance). Also check oil, fuel, and coolant levels.

1. Start the engine to measure the low-end RPM. Let idle for 10 minutes.
2. With the engine at idle, check the low-end RPM. Adjust to 1150-1200. To decrease speed, loosen the idle adjustment bolt. To increase speed, tighten the idle adjustment bolt. Tighten the lock nut to hold the bolt in place.

See Figure 3-5.

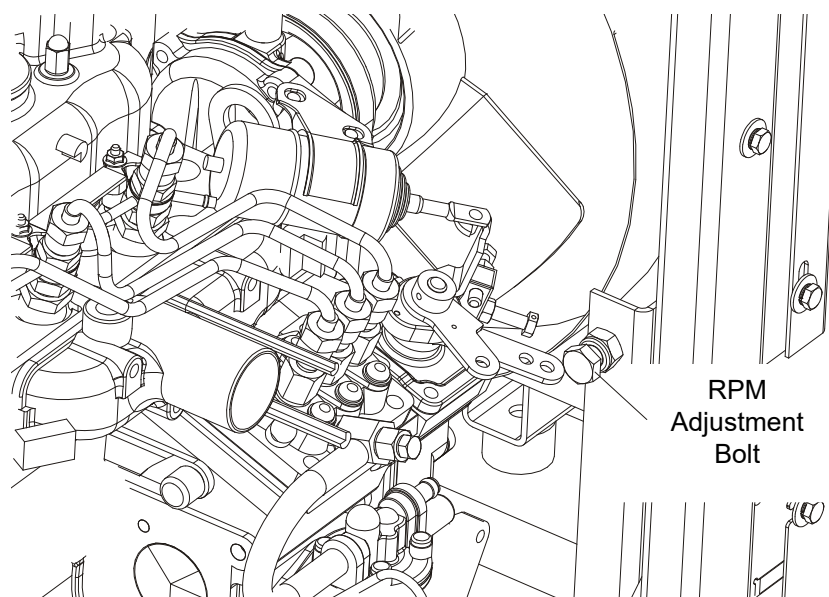



FIG. 3-5

 **CAUTION!** Do not adjust the high-end RPM.

3.11 Storage

Short Term Storage

If storing the engine over 30 days but under 6 months, take the following maintenance steps:

1. Idle the engine for 15 minutes before shutting off.
2. Drain oil and refill crankcase with protection oil MIL-1-644-P9. Run engine at 3/4 full speed for 5-10 minutes.
3. Shut off engine.
4. While the engine is still warm, drain oil. Refill crankcase with standard oil.
5. Remove the fuel filter and drain the fuel tank. Replace gasket if need and reinstall the fuel filter.
6. Carefully clean the radiator fins, heads and fan.
7. Seal all openings with tape.
8. Remove injectors. Poor a spoonful of SAE 30 oil into the cylinders. Manually rotate the cylinders to distribute the oil. Reinstall injectors.
9. Spray SAE 10W oil into exhaust and intake manifolds, rocker arm, valves, tappet, etc. Grease all unpainted parts.
10. Loosen the fan belt.
11. Wrap the engine in a plastic film.
12. Store the engine in a dry place. Keep away from soil and high voltage electric lines.

Long Term Storage

If storing over 6 months follow these additional guidelines:

1. Use a rustproof type MIL-L-21260-P10 grade 2 SAE 30 oil, such as ESSO RUST BAN 623-AGIP, RUSTIA C - SAE 30 for the lubrication and the injection system as well as for moving parts. Let the engine run with rustproof oil and drain any excess.
2. Coat the external unpainted surfaces with an antirust type MIL-C-16173D grade 3 oil, such as ESSO RUST BAN 398-AGIP, RUSTIA 100/F.

SECTION 4 REPLACEMENT PARTS

4.1 How To Use The Parts List

- Use the table of contents or the index to locate the assembly that contains the part you need.
- Go to the appropriate section and locate the part in the illustration.
- Use the number pointing to the part to locate the correct part number and description in the table.
- Parts shown indented under another part are included with that part.
- Parts marked with a diamond (◆) are only available in the assembly listed above the part.

See the sample table below. Sample Part #A01111 includes part F02222-2 and subassembly A03333. Subassembly A03333 includes part S04444-4 and subassembly K05555. The diamond (◆) indicates that S04444-4 is not available except in subassembly A03333. Subassembly K05555 includes parts M06666 and F07777-77. The diamond (◆) indicates M06666 is not available except in subassembly K05555.

4.2 Sample Assembly				
REF.	DESCRIPTION (◆ Indicates Parts Available In Assemblies Only)	PART #	QTY	
	SAMPLE ASSEMBLY, COMPLETE (INCLUDES ALL INDENTED PARTS BELOW)	A01111	1	
1	Sample Part	F02222-22	1	
	Sample Subassembly (Includes All Indented Parts Below)	A03333	1	
2	Sample Part (◆ Indicates Part Is Only Available With A03333)	S04444-4	1	◆
	Sample Subassembly (Includes All Indented Parts Below)	K05555	1	
3	Sample Part (◆ Indicates Part Is Only Available With K05555)	M06666	2	◆
4	Sample Part	F07777-77	1	

To Order Parts:

- From the continental U.S., call our toll-free Parts hotline at **1-800-448-7881**. From Europe call our European Headquarters and Manufacturing Facility in Kolo, Poland at **+48-63-2626000** or **+48-3912-1319**. Have your customer number, vehicle identification number, and part numbers ready when you call.
- From other international locations, contact the Wood-Mizer distributor in your area for parts.

4.3 Fuel Tank Assembly

518349_001
518349

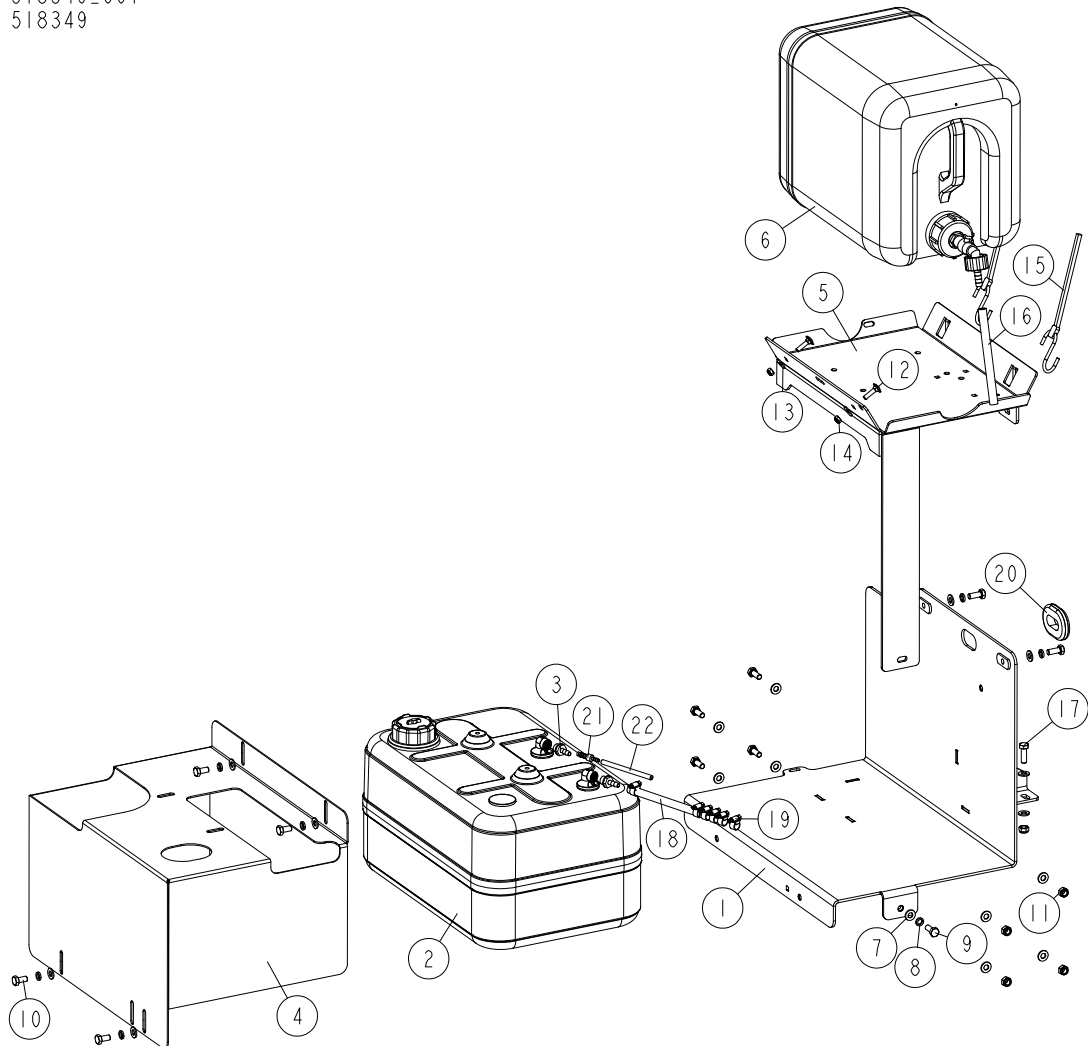

REF	DESCRIPTION (u indicates parts available in assemblies only)	PART #	QTY
-	TANK ASSEMBLY, LT20 DIESEL	518349	1
1	PLATE, FUEL TANK - COMPLETE	518348-1	1
-	FUEL TANK, 25-LITRE	550767	1
2	FUEL TANK, 25-LITRE	550772	1
3	FITTING, STRAIGHT HOSE 1/4" X 6 MM	550770	2
4	COVER, FUEL TANK	550769-1	1
5	TRAY, LT20 WATER BOTTLE	539074-1	1
6	TANK, OIL See Section 4.4	550787	1
7	WASHER, 8.4 FLAT ZINC	F81054-1	17
8	WASHER, 8.2 SPLIT LOCK ZINC	F81054-4	7
9	BOLT, M8X20 8.8 HEX HEAD FULL THREAD ZIN	F81002-4	7
10	BOLT, M8X16-8.8-B HEX HEAD FULL THREAD Z	F81002-20	4
11	NUT, M8-8-B HEX NYLON ZINC LOCK	F81032-2	5
12	BOLT, M6X25-8.8 ZINC	F81001-20	2
13	WASHER, FLAT ZINC	F81053-11	2

4 Replacement Parts

Fuel Tank Assembly

REF	DESCRIPTION (u indicates parts available in assemblies only)	PART #	QTY	
14	NUT, M6-8-B HEX NYLON ZINC LOCK	F81031-2	2	
15	STRAP, 20" RUBBER W/HOOK	P11668	2	
16	TUBING, WATER LUBE 3/8" I.D.	R01885	1	
17	BOLT, M8X25-8.8-B HEX HEAD FULL THREAD Z	F81002-5	1	
18	FUEL LINE, DIESEL ENGINE	P642	1	
19	CLAMP, 8-12MM DIA. WORM	F81080-1	6	
20	GROMMET, 26MM I.D. RUBBER	085613	1	
21	FITTING, STRAIGHT HOSE 6 MM - 4 MM	518336	1	
22	HOSE, CARBURANTE 3,2 X 7 ID FUEL	R80703-3	1	

4.4 Water Bottle

550787_001
550787

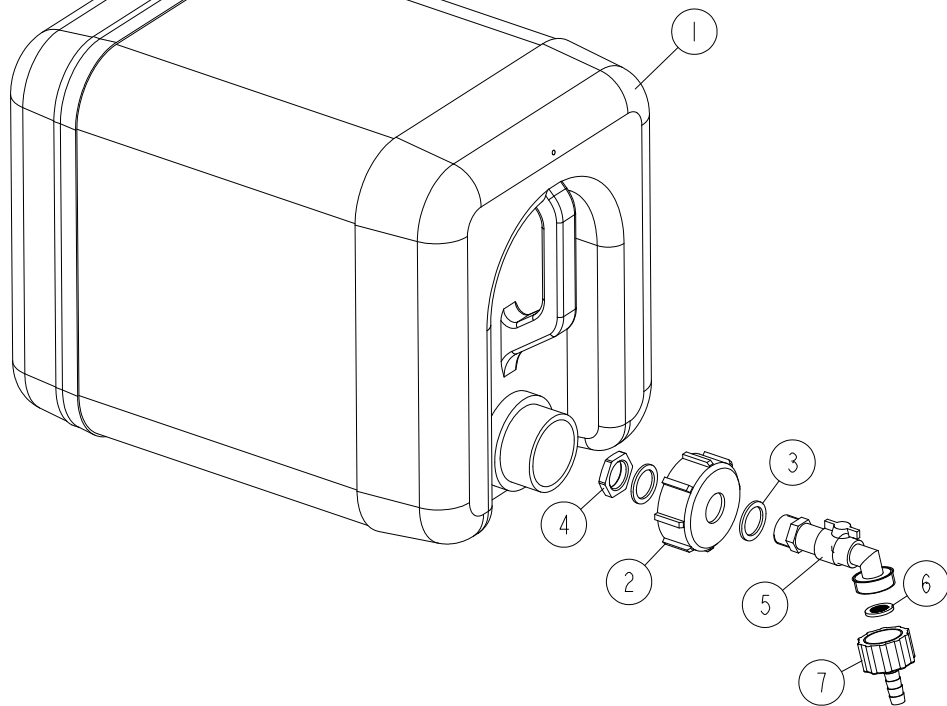

REF	DESCRIPTION (u indicates parts available in assemblies only)	PART #	QTY
-	TANK, OIL	550787	1
1	BOTTLE, WATER	513866	1
2	NUT, BOTTLE	550785	1
3	SEAL, 27X20X1.5 ESSENTA 467673 RUBBER	550780	2
4	NUT, 1/2 ESSENTA 467615 GLAND	550779	1
5	FITTING, WATER LUBE SHUTOFF VALVE	550776	1
6	FILTER, WATER LUBE	550778	1
7	FITTING, G3/4" X 10MM HOSE BARB	550777	1

4 Replacement Parts

Belt Tensioner

4.5 Belt Tensioner

598020_001
598020

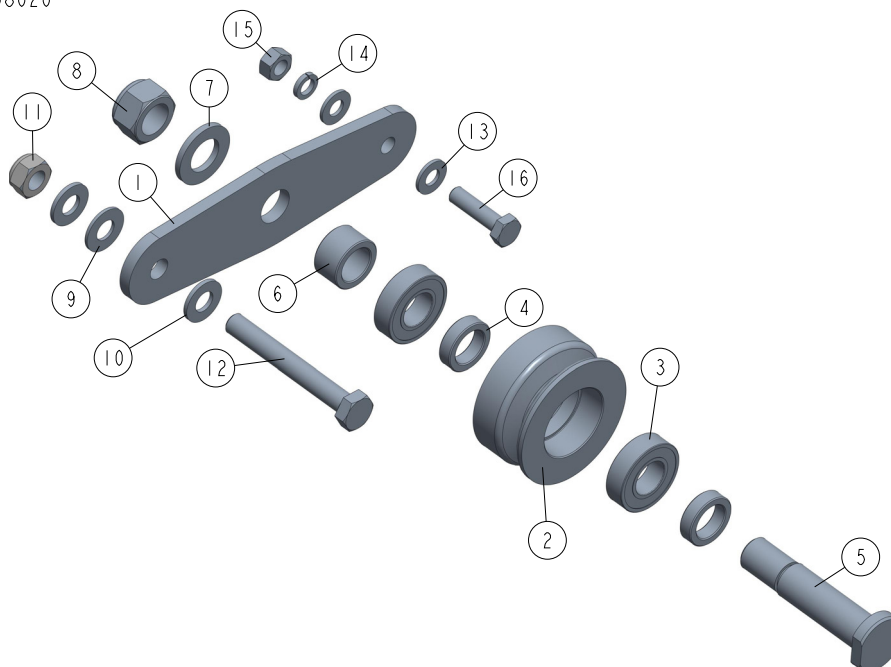

REF	DESCRIPTION (u indicates parts available in assemblies only)	PART #	QTY
-	BELT TENSIONER	598020	1
1	PLATE, TENSIONER	598017-1	1
2	PULLEY, D22/105 AMP. ALTERNATOR	598011-1	1
3	BEARING, 6003-2RS ROLLING	086116	2
4	BUSHING, 17.1/25-7	598018-1	2
5	SHAFT, KUBOTA ENGINE BELT TENSIONER	087960-1	1
6	BUSHING, 17.1/25-14.3	598019-1	1
7	WASHER, 17 ZINC FLAT	F81058-1	1
8	NUT, M16-8 HEX NYLON ZINC LOCK	F81036-2	1
9	WASHER, 10.5/22-1.5	598039	1
10	WASHER, 10.5 FLAT ZINC	F81055-1	2
11	NUT, M10-8-B NYLON HEX ZINC LOCK	F81033-1	1
12	BOLT, M10X75-8.8 HEX HEAD ZINC	F81003-15	1
13	WASHER, 8.4 ZINC FLAT	F81054-1	2
14	WASHER, 8.2 SPLIT LOCK ZINC	F81054-4	1
15	NUT, M8-8-B HEX ZINC	F81032-1	1
16	BOLT, M8X30 8.8 HEX HEAD FULL THREAD ZIN	F81002-7	1

4.6 Engine Mount Assembly

D25_004
D25-20_MANUAL

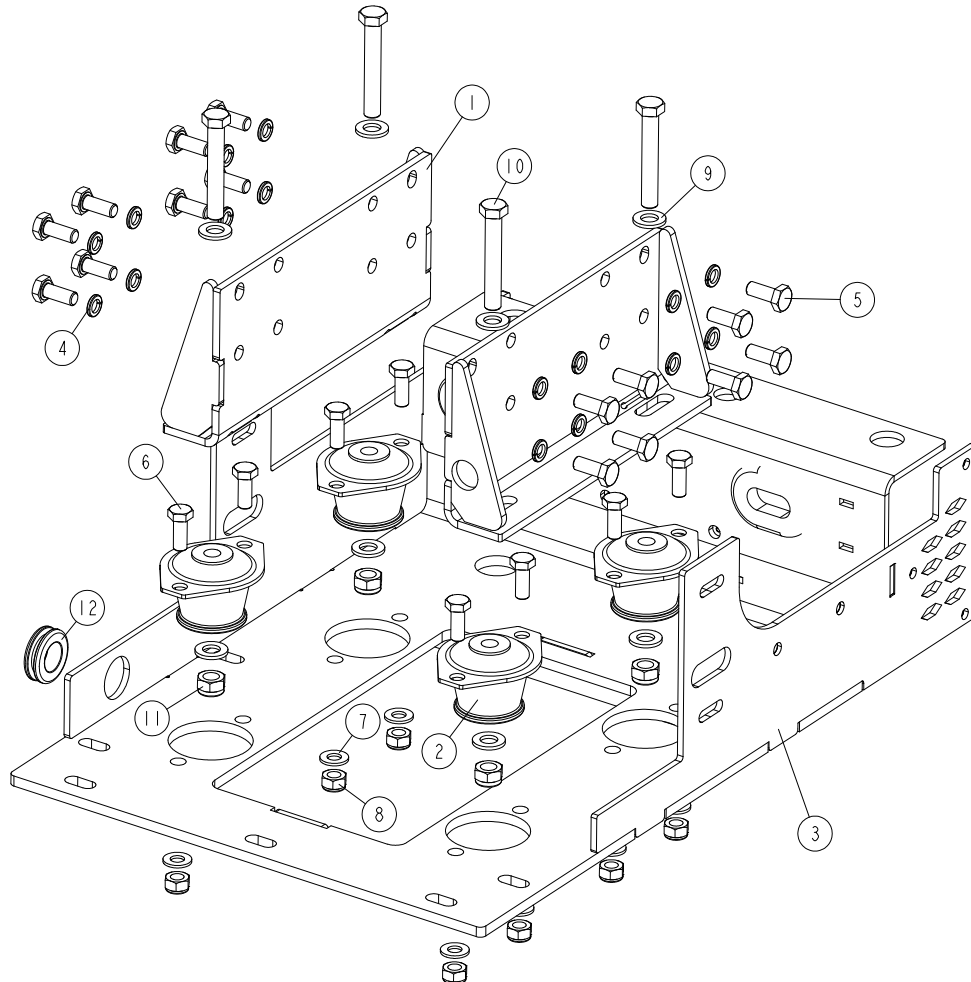

REF	DESCRIPTION (u indicates parts available in assemblies only)	PART #	QTY
1	BRACKET, D1005 KUBOTA ENGINE MOUNT	092343-1	2
2	ABSORBER, #210355.65 SHA SHOCK	091933	4
3	MOUNT WELDMENT, D1005 KUBOTA ENGINE	598040-1	1
4	WASHER, 10.2 SPLIT LOCK ZINC	F81055-2	16
5	BOLT, M10X1.25X25-8.8-A HEX HEAD FULL TH	F81003-29	16
6	BOLT, M10X25-8.8 HEX HEAD FULL THREAD ZI	F81003-11	8
7	WASHER, 10.5 FLAT ZINC	F81055-1	8
8	NUT, M10-8-B NYLON HEX ZINC LOCK	F81033-1	8
9	WASHER, 13 FLAT ZINC	F81056-1	8
10	BOLT, M12 X 75-8.8 HEX HEAD ZINC	F81004-21	4
11	NUT, M12-8 HEX NYLON ZINC LOCK	F81034-2	4
12	GROMMET, 22MM RUBBER	087400	2

4

Replacement Parts

Engine Assembly

4.7 Engine Assembly

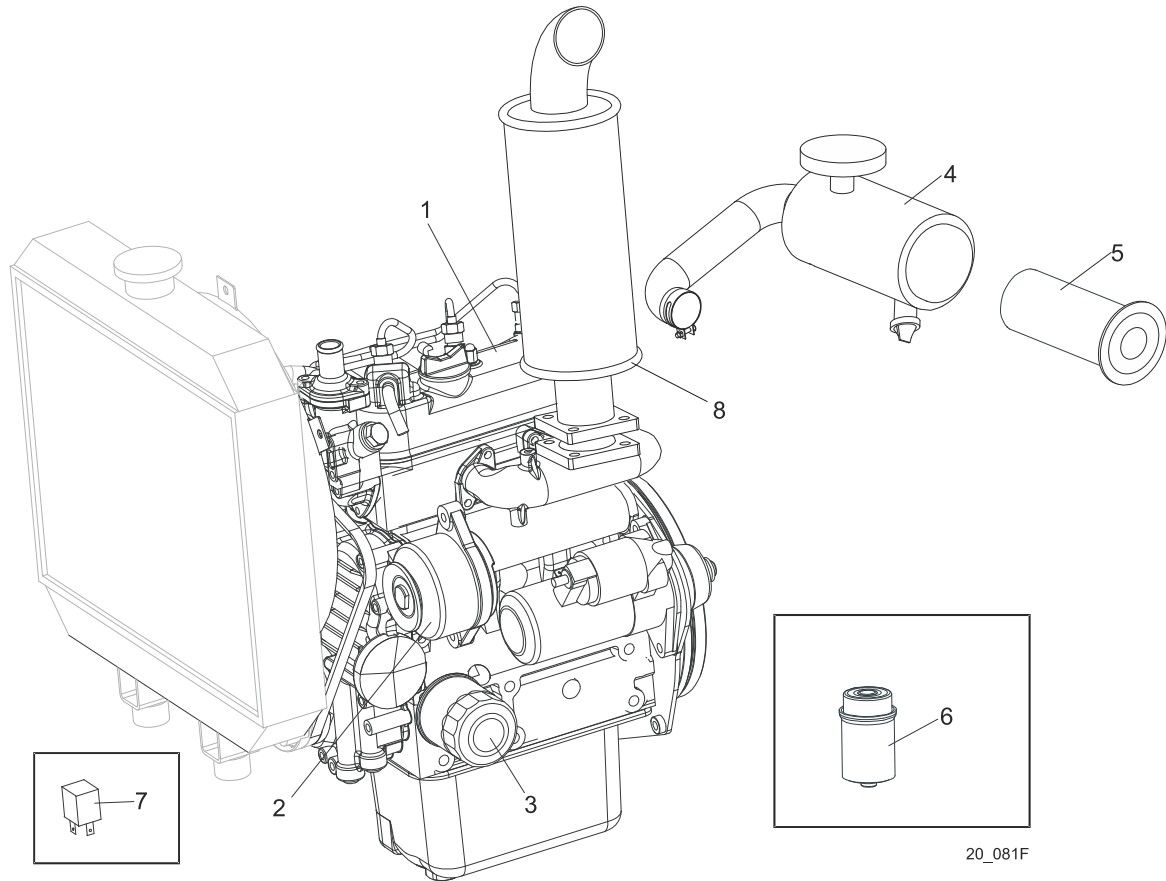

20_081F

REF	DESCRIPTION (◆ Indicates Parts Available In Assemblies Only)	PART #	QTY.	
1	ENGINE, D22 D1005-E3B-EU-XL1	100929	1	◆
2	ALTERNATOR D722 16241-64010 (AFRICAN VERSION ONLY)	092206	1	
	ALTERNATOR ASSY, 105A/D22	097905	1	
3	FILTER, D22 "KUBOTA" #16271-32092 OIL	093600	1	
4	FILTER, D22 KUBOTA AIR	100427	1	
5	Element, D22 "Kubota" #15741-11083 Air Filter	093601	1	
6	CARTRIDGE, D22 "KUBOTA" #15221-43080 FUEL FILTER	093602	1	
7	RELAY, #191911261C GLOW PLUG	088143	1	
8	MUFFLER, D1005 KUBOTA ENGINE	092652	1	
	FILTER, D22 FUEL ASSEMBLY	098139	1	
	FUEL PRE-FILTER, D1005 KUBOTA ENGINE	092706	1	
	GLOW PLUG, KUBOTA	093473	3	
	Belt, Kubota Fan	097739	1	
	Radiator Fan	097740	1	
	Gasket Kit, Kubota Lower	097744	1	
	Gasket Kit, Kubota Upper	097745	1	
	Gasket, Kubota Muffler	097746	1	
	Gasket, Kubota Fuel Injector	097747	1	
	Gasket, Kubota Fuel Transfer Pump	097748	1	

	Gasket, D22 Kubota Head	098344	1	
	Gasket, Kubota Oil Drain Plug	097750	1	
	Gasket, Kubota Stop Solenoid	097751	1	
	Gasket, Kubota Thermostat	097752	1	
	Gasket, Kubota Valve Cover	097753	1	
	Gasket, Kubota Water Pump	097754	1	
	Gasket, D22 Kubota Exhaust Manifold	098343	1	
	Glow Plug, Kubota	097756	1	
	Injection Sprayer, Fuel D22 Kubota	098345	1	
	Motor, Kubota Starter	097759	1	
	Plug, Kubota Oil Drain	097760	1	
	Pump, Kubota Fuel Transfer	097762	1	
	Pump, Kubota Water	097763	1	
	Radiator Parts (See Section 4.24)			
	Sending Unit, Kubota Heat Sensor	097764	1	
	Solenoid, Kubota Stop	097765	1	
	Switch, Kubota Oil Pressure	097766	1	
	Thermostat, Kubota	097767	1	
	Oil Filling Cap Kubota	097768	1	
	Coolant Temperature Sensor	097769	1	
	HARNES ASSEMBLY, KUBOTA DIESEL ENGINE	088144	1	
	Breaker Assembly, Water Temp. Max Circuit	N/A	1	
	Socket, Glow Plug Relay w/Fuse Holder	N/A	1	
	Fuse Link, 50 Amp	N/A	1	
	Relay, Glow Plug	092277	1	

4 Replacement Parts

Alternator Assembly

4.8 Alternator Assembly

598025_001
598025

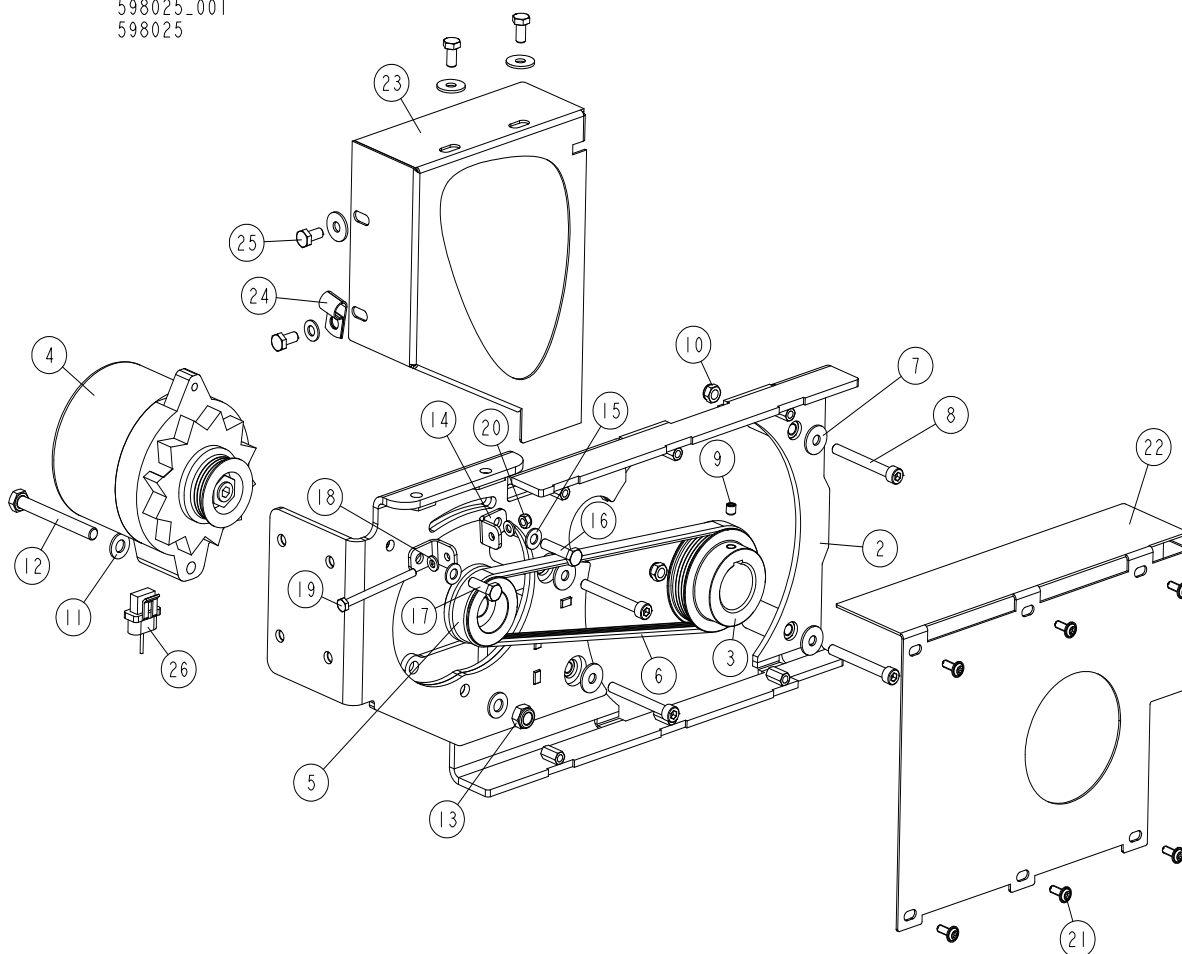

REF	DESCRIPTION (u indicates parts available in assemblies only)	PART #	QTY
1	ALTERNATOR ASSY. LT20/D22/D25	598025	1
2	BRACKET WELDMENT, ALTERNATOR	598030-1	1
3	PULLEY, 105 AMP ALTERNATOR	598036-1	1
4	ALTERNATOR, 105A 12V CS130	050287	1
5	PULLEY, 105A (050287) ALTERNATOR ZINC-PL	506378-1	1
6	BELT, 4PK755	097815	1
7	WASHER, 8.5 SPECIAL FLAT ZINC	F81054-11	7
8	SCREW, ISO 4762 M8X70-8.8-A2E HEX SOCKET	F81002-100	4
9	SCREW, M8 X 8-33H HEX SOCKET SET FLAT PO	F81014-1	1
10	NUT, M8-8-B HEX NYLON ZINC LOCK	F81032-2	3
11	WASHER, 10.5 FLAT ZINC	F81055-1	2
12	BOLT, M10X90-8.8-B-HEX HEAD ZINC	F81003-66	1
13	NUT, M10-8-B NYLON HEX ZINC LOCK	F81033-1	1
14	TENSIONER, 30A ALTERNATOR BELT	095296-1	2
15	WASHER, 8.4 ZINC FLAT	F81054-1	4
16	BOLT, M8X35-8.8 HEX HEAD FULL THREAD ZIN	F81002-13	1
17	BOLT, M8X25-8.8-B HEX HEAD FULL THREAD Z	F81002-5	1

REF	DESCRIPTION (u indicates parts available in assemblies only)	PART #	QTY	
18	WASHER, 6.4 FLAT ZINC	F81053-1	2	
19	BOLT, M6 X 80 5.8 HEX HEAD FULL THREAD Z	F81001-61	1	
20	NUT, M6-8-B HEX NYLON ZINC LOCK	F81031-2	1	
21	SCREW, M6X16 BN 11252 "BOSSARD"	F81001-24	6	
22	COVER	598048-1	1	
23	COVER, ALTERNATOR	598049-1	1	
24	CLAMP, 1/2" EMT COATED	P07584	1	
25	BOLT, M8X16 -8.8-B HEX HEAD FULL THREAD	F81002-20	4	
26	WIRE ASSEMBLY, 61/105 AMP ALTERNATOR PLU	015969	1	

4 Replacement Parts

Drive Assembly

4.9 Drive Assembly

D25-001
D25-20_MANUAL

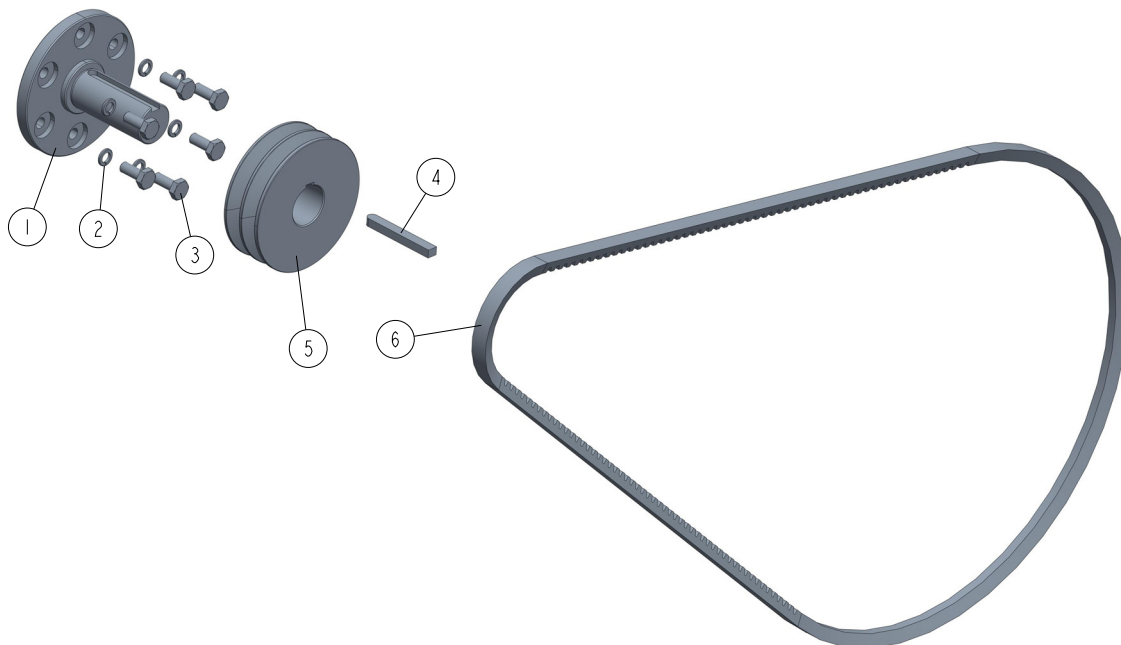

REF	DESCRIPTION (u indicates parts available in assemblies only)	PART #	QTY
-	SHAFT, D22 KUBOTA ENGINE	598034	1
1	SHAFT, D1005 KUBOTA ENGINE OUTPUT	598035	1
2	WASHER, 10.2 SPLIT LOCK ZINC	F81055-2	6
3	BOLT, M10X1.25X25-8.8-A HEX HEAD FULL TH	F81003-29	6
4	KEY, 10X8X80	598050	1
5	PULLEY, E15 MOTOR 2-GROOVE	091560	1
6	DRIVE BELT, 2BX84, DC SAWMILLS (D17, D22	088110	1

4.10 Throttle Assembly

092346-CE_001
092346-CE

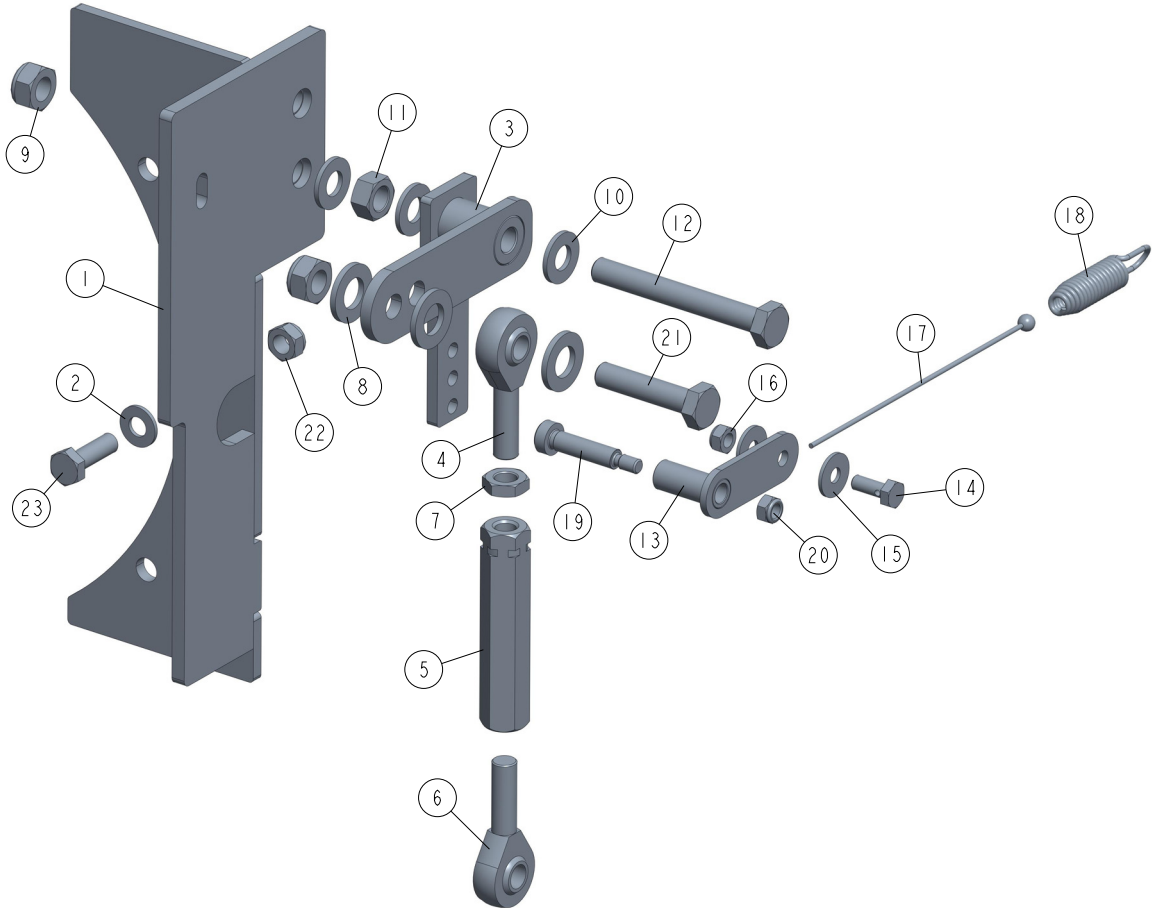

REF	DESCRIPTION (u indicates parts available in assemblies only)	PART #	QTY
1	BRACKET, PIVOT LEVER MOUNT	092362-1	1
2	WASHER, 8.4 ZINC FLAT	F81054-1	2
3	LEVER WELDMENT, THROTTLE PIVOT PTD	598037-1	1
4	END, SAL10 ROD THREAD	096431	1
5	TURNBUCKLE	518243-1	1
6	ROD END, SA10	094236	1
7	NUT, M10-04-W THIN ZINC	F81033-6	1
8	WASHER, 13 FLAT ZINC	F81056-1	3
9	NUT, M10-8-B NYLON HEX ZINC LOCK	F81033-1	2
10	WASHER, 10.5 FLAT ZINC	F81055-1	3
11	NUT, M10-8-B HEX ZINC	F81033-3	1
12	BOLT, M10 X 80-8.8 HEX HEAD ZINC	F81003-50	1
-	BAR, THROTTLE COMPLETE	092703	1
13	BAR, THROTTLE	092702-1	1
14	BOLT, THROTTLE CABLE CLAMP ZINC-PLATED	088120-1	1
15	WASHER, 6.5 FLAT ZINC	F81053-11	2

4**Replacement Parts***Throttle Assembly*

REF	DESCRIPTION (u indicates parts available in assemblies only)	PART #	QTY	
16	NUT, M6-8-B HEX NYLON ZINC LOCK	F81031-2	1	
17	CABLE KIT, KUBOTA D1005 THROTTLE REPL	092695	1	
18	SPRING 40X9X2.2 EXTENSION	089451	1	
19	SCREW, 8/M6X30-12.9 SOCKET HEAD SHOULDER	F81001-18	1	
20	NUT, M6-8-B HEX NYLON ZINC LOCK	F81031-2	1	
21	BOLT, M10X45-8.8 HEX HEAD FULL THREAD ZI	F81003-3	1	
22	NUT, M8-8-B HEX NYLON ZINC LOCK	F81032-2	1	
23	BOLT, M8X25-8.8-B HEX HEAD FULL THREAD Z	F81002-5	1	

4.11 Radiator Assembly & D22 Engine Guards

D25_003
D25-20_MANUAL

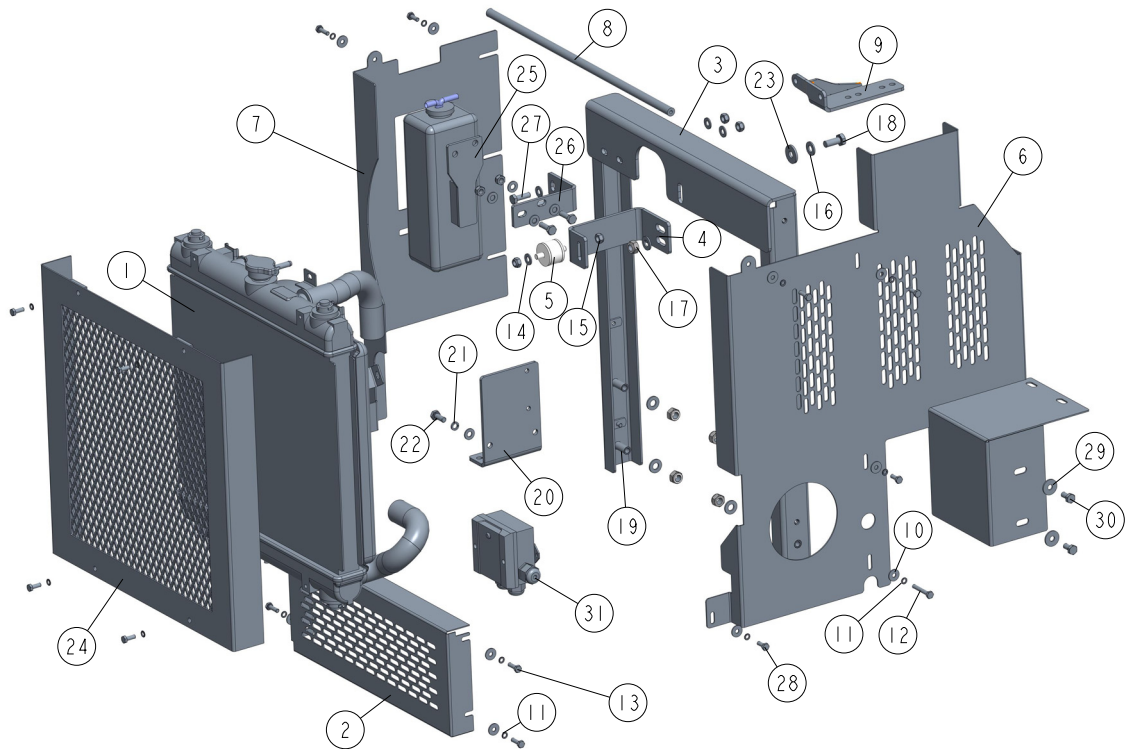

REF	DESCRIPTION (u indicates parts available in assemblies only)	PART #	QTY
1	RADIATOR, D22 KUBOTA ENGINE	097321	1
2	GUARD, D22 ENGINE REAR	097796-1	1
3	BRACKET, RADIATOR MOUNT	097790-1	1
4	BRACKET, D22 KUBOTA RADIATOR PTD	097322-1	1
5	RADIATOR JOINT, METAL-RUBBER	088183	1
6	SIDE COVER	598045-1	1
7	GUARD, D1005 KUBOTA ENGINE RIGHT	097330-1	1
8	BAR, D22 ENGINE MOUNT SPACER	092003-1	1
9	BRACKET	567580-1	1
10	WASHER, 6.5 FLAT ZINC	F81053-11	15
11	WASHER, Z6.1 SPLIT LOCK ZINC	F81053-3	19
12	BOLT, M6X40-8.8 HEX HEAD FULL THREAD ZIN	F81001-5	1
13	BOLT, M6X20-8.8 HEX HEAD FULL THREAD ZIN	F81001-2	6
14	WASHER, 8.4 ZINC FLAT	F81054-1	12
15	NUT, M8-8-B HEX NYLON ZINC LOCK	F81032-2	6
16	WASHER, 10.5 FLAT ZINC	F81055-1	8
17	NUT, M10-8-B NYLON HEX ZINC LOCK	F81033-1	5
18	BOLT, M10X25-8.8 HEX HEAD FULL THREAD ZI	F81003-11	1
19	SPACER, DRIVE BEARING ZINC	092008-1	4
20	BRACKET, D1005 FUEL FILTER	092529-1	1
21	WASHER, 8.2 SPLIT LOCK ZINC	F81054-4	2

4**Replacement Parts***Radiator Assembly & D22 Engine Guards*

REF	DESCRIPTION (u indicates parts available in assemblies only)	PART #	QTY	
22	BOLT, M8X20-8.8-B HEX HEAD FULL THREAD Z	F81002-4	2	
23	WASHER, 10.5 SPECIAL FLAT ZINC	F81055-6	1	
24	RADIATOR GUARD, D22 KUBOTA ENGINE	098486-1	1	
25	BOTTLE, D22/D33 ENGINE WATER TANK	097329	1	
26	BRACKET, D22 WATER BOTTLE	097331-1	1	
27	BOLT, M8X25-8.8-B HEX HEAD FULL THREAD Z	F81002-5	4	
28	BOLT M6X16 HH ZC FT 8.8 DIN 933	F81001-15	12	
29	WASHER, 8.5 SPECIAL FLAT ZINC	F81054-11	2	
30	BOLT, M8X16 -8.8-B HEX HEAD FULL THREAD	F81002-20	2	
31	RELAY, SAFETY KEY SWITCH	086486	1	