

G18 Engine

Safety, Operation, Maintenance & Parts Manual

LT20 Series

rev. A1.00



Safety is our #1 concern! Read and understand all safety information and instructions before operating, setting up or maintaining this machine.

November 2003

Form #617

Table of Contents

Section-Page

SECTION 1 OPERATION

1-1

1.1 Starting The Engine1-1

SECTION 2 MAINTENANCE

2-1

2.1 Safety2-1

2.2 Cooling System2-2

2.3 Air Filter & Pre-Cleaner2-2

2.4 Fuel Filter2-2

2.5 Battery2-3

2.6 Alternator Belt2-4

2.7 RPM Adjustments2-5

2.8 Miscellaneous Maintenance2-6

SECTION 3 REPLACEMENT PARTS

3-1

3.1 How To Use The Parts List3-1

3.2 Sample Assembly3-1

3.3 Fuel Tank Assembly3-2

3.4 Engine Mount Assembly3-4

3.5 Engine Assembly3-5

3.6 Muffler Assembly3-6

3.7 Drive Assembly3-7

3.8 Throttle Cable Assembly3-8

3.9 Alternator Assembly3-9

SECTION 4 ELECTRICAL INFORMATION

4-1

4.1 Electrical Wiring Diagram, G18 Engine4-1

4.2 Electrical Components, G18-20S4-3

ABOUT THIS MANUAL

This manual is provided as a supplement to the equipment manufacturer's manuals. This manual provides information specific to the use of this equipment on the Wood-Mizer® sawmill. Refer to the sawmill operator's manual and manufacturer's manual before attempting to operate this equipment.



IMPORTANT! Read the sawmill operator's manual and engine manufacturer's manual for instructions and safety precautions before operating this equipment.

The information and instructions given in this manual do not amend or extend the limited warranties for the equipment given at the time of purchase.

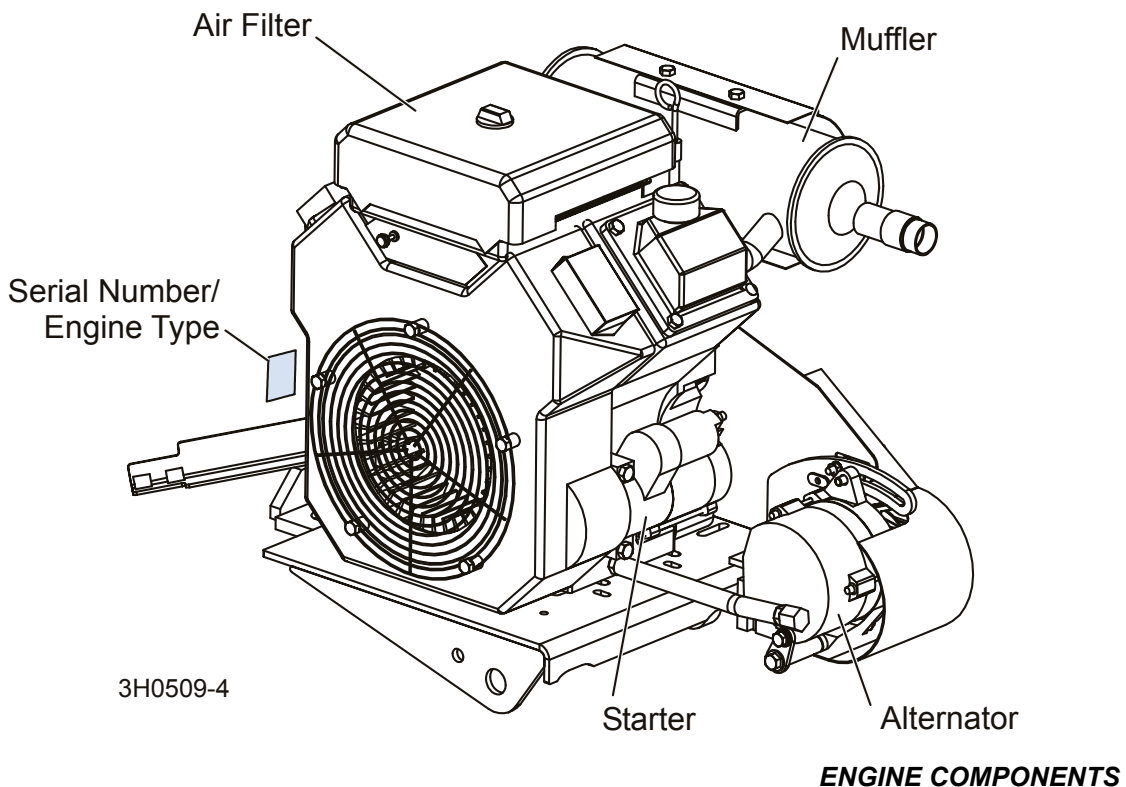

SECTION 1 OPERATION

1.1 Starting The Engine

Engine Control Lights

See **Figure 1-1**. The following indicator lights are located on the sawmill control panel.

 *Alternator Charge Indicator*: Lights up if the alternator is not charging the battery.



 *Oil Indicator*: Lights up if the oil pressure is too low.

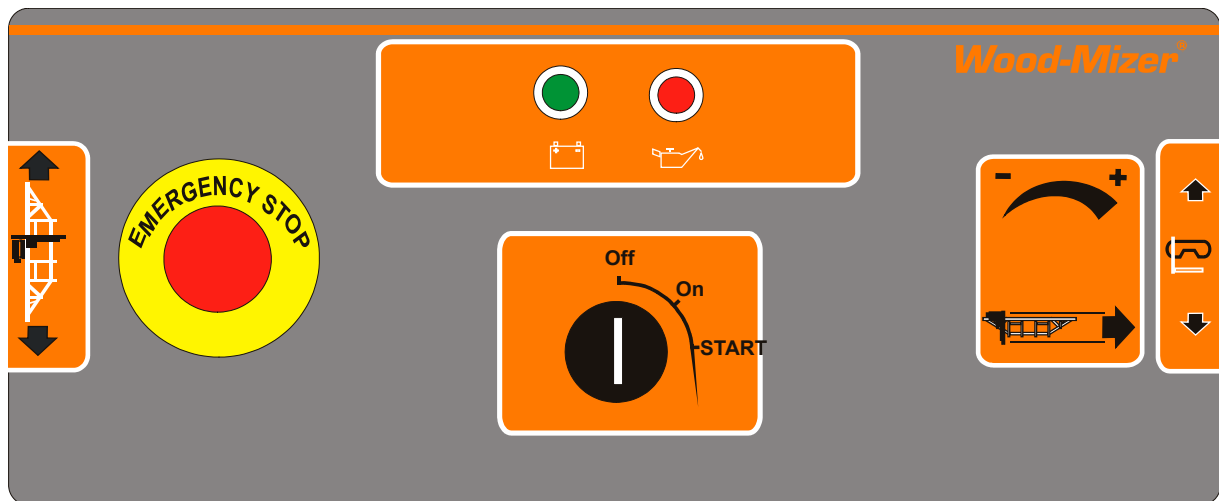

FIG. 1-1

Engine Start



DANGER! Always be sure the blade is disengaged and all persons are out of the path of the blade before starting the engine. Failure to do so will result in serious injury.

DANGER! Operate your engine/machine only in well ventilated areas. The exhaust gases of your engine can cause nausea, delirium and potentially death unless adequate ventilation is present.

DANGER! Never operate an engine with a fuel or oil leak. The leaking fuel or oil could potentially come in contact with hot surfaces and ignite into flames.



WARNING! Be sure the power feed switch is in the neutral position before turning the key switch to the on (#1) position. This prevents accidental carriage movement, which may cause serious injury or death.

WARNING! Do not operate engine without proper and operational spark arrester/muffler. Sparks emitted from the engine exhaust could ignite surrounding materials, causing serious injury or death.

Turn the key switch to the start (#2) position and release.

If the engine needs choking to start, pull the choke cable out until the engine starts. Push the choke wire in after the engine starts.

For more information, see the engine manufacturer's operation manual.

If the fuel tank was recently filled or replaced, squeeze the primer bulb once or twice before trying to start the engine. **NOTE:** If pumping problems are experienced, make sure the out-flow end of the hose line is connected to the fuel filter. If pumping problems are still experienced, hold the primer bulb in a vertical position while squeezing. This allows the fuel check valve to operate properly.

NOTE: When the clutch handle is engaged, an accelerator pump is activated which supplies fuel to the engine carburetor. To avoid flooding the carburetor and possibly fouling the spark plugs, do not engage the clutch lever repeatedly without the engine running.

1 Operation

Starting The Engine

Engine Shutoff

Turn the key switch to the off (#0) position.

SECTION 2 MAINTENANCE

Refer to the manufacturer's manual for maintenance intervals and procedures unless otherwise instructed in this manual. Follow the manufacturer's recommendations for dusty conditions.



IMPORTANT! This manual only provides information about additional procedures or procedures to be performed at different time intervals than found in the manufacturer's manuals. Refer to the manufacturer's manual for complete maintenance instructions.

2.1 Safety

Use caution when performing maintenance or service to the engine.



DANGER! Always be aware of and take proper protective measures against rotating shafts, pulleys, fans, etc. Always stay a safe distance from rotating members and make sure that loose clothing or long hair does not engage rotating members resulting in possible injury.

DANGER! Engine components can become very hot during operation. Avoid contact with any part of a hot engine. The exhaust components of your engine are especially hot during and following operation. Contact with hot engine components can cause serious burns. Therefore, never touch or perform service functions on a hot engine. Allow the engine to cool sufficiently before beginning any service function.



WARNING! Remove the blade before performing any engine service. Failure to do so may result in serious injury.

WARNING! Always wear proper and necessary safety equipment when performing service functions. Proper safety equipment includes eye protection, breathing protection, hand protection and foot protection.





This symbol identifies the interval (hours of operation) at which each maintenance procedure should be performed. "AR" signifies maintenance procedures which should be performed as required.

2.2 Cooling System

 Wash the engine or brush off sawdust and debris every 50 hours of operation. Clean the grass screen, cooling fins, and external surfaces. Remove any dust, dirt or oil. See engine manual for further instructions.

2.3 Air Filter & Pre-Cleaner

 **WARNING!** Always wear proper and necessary safety equipment when performing service functions. Proper safety equipment includes eye protection, breathing protection, hand protection and foot protection.

 Service the pre-cleaner every four hours of operation. Service by gently shaking excess sawdust and debris from the foam piece.

 Clean the air filter (air cleaner element) and pre-cleaner (element wrapper) every eight hours of operation. See the engine manual for further instructions.

 Replace the air filter (cleaner) every 200 hours of operation.

 Replace the pre-cleaner (element wrapper) every 2000 hours of operation.

2.4 Fuel Filter

 Replace the fuel filter every 100 hours of operation.

2.5 Battery



Check the battery electrolyte level every 50 hours of operation. See manufacturer's manual for instructions.



DANGER! Batteries expel explosive gases. Keep sparks, flames, burning cigarettes, or other ignition sources away at all times. Always wear safety goggles and a face shield when working near batteries. Failure to do so will cause serious injury.¹



WARNING! Battery posts, terminals and related accessories contain lead and lead compounds, chemicals known to the State of California to cause cancer and reproductive harm. Wash hands after handling.

1. Battery Council International, copyright 1987

2.6 Alternator Belt



Adjust the alternator belt as needed. Check the alternator belt for tension and wear when battery is not charging properly or when the alternator belt is squealing. To tighten the belt, loosen the adjustment bolt and lock washer. Pivot the alternator away from the motor until the belt has 7/16" (11 mm) deflection with a 5 lb. deflection force. Retighten the adjustment bolt.

See Figure 2-1.

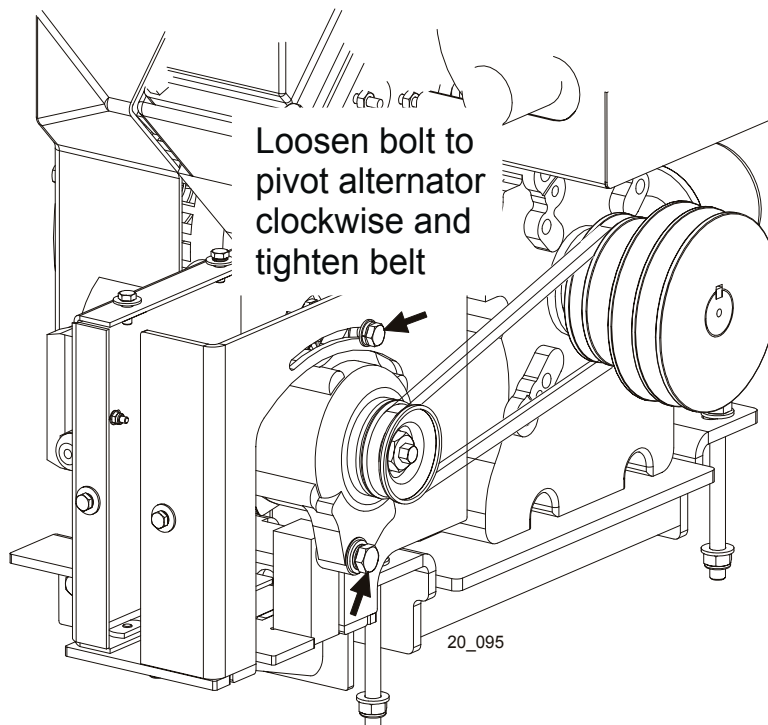

FIG. 2-1

2.7 RPM Adjustments



WARNING! Remove the blade before performing any engine service. Failure to do so may result in serious injury.

200

Check the RPM with a tachometer after the first 20 hours of operation and every 200 hours thereafter. High-end RPM should be 3750 RPM and low-end RPM should be 1800 RPM (± 100).

Before checking the RPM, make sure belt and brake strap tensions are correct (See Saw-mill Maintenance). Also check oil and fuel levels.

Make sure the throttle cable does not affect the engine RPM when the clutch handle is disengaged. Make sure the cable is not bent or kinked. Check that the cable spring, cable guide, cable, and throttle brackets are aligned. **NOTE:** It is important that the above components are aligned. Proper alignment allows any slack in the cable (when engine is idling) to slide down into the cable spring. This maintains free operation of the cable and prevents the cable from kinking.

1. Start the engine to measure the low-end RPM.
2. Refer to the engine manual to adjust the low-end RPM.
3. Engage the clutch handle to throttle the engine and measure the high-end RPM. The high-end RPM is factory-set at 3750. Readjust the throttle cable if necessary to increase or reduce the high-end engine speed.

The throttle cable should be tensioned just enough so that the engine revs as soon as the clutch/brake handle is engaged. **NOTE:** A properly adjusted throttle will extend the cable spring 1/4" to 3/8" (6.4 - 9.5 mm) when running and have a slight amount of slack in the cable when idling.

2.8 Miscellaneous Maintenance



Clean and inspect the spark arresters every 50 hours of operation. Replace if damaged.



Inspect the spark plugs every 100 hours of operation. Remove any deposits and adjust gap if necessary. See engine manual for further information.



CAUTION! Do not remove the plug wire to check for electrical spark. Damage to the ignition circuit will result.

SECTION 3 REPLACEMENT PARTS

3.1 How To Use The Parts List

- Use the table of contents or the index to locate the assembly that contains the part you need.
- Go to the appropriate section and locate the part in the illustration.
- Use the number pointing to the part to locate the correct part number and description in the table.
- Parts shown indented under another part are included with that part.
- Parts marked with a diamond (◆) are only available in the assembly listed above the part.

See the sample table below. Sample Part #A01111 includes part F02222-2 and subassembly A03333. Subassembly A03333 includes part S04444-4 and subassembly K05555. The diamond (◆) indicates that S04444-4 is not available except in subassembly A03333. Subassembly K05555 includes parts M06666 and F07777-77. The diamond (◆) indicates M06666 is not available except in subassembly K05555.

3.2 Sample Assembly				
REF	DESCRIPTION (◆ Indicates Parts Available In Assemblies Only)	PART #	QTY.	
	SAMPLE ASSEMBLY, COMPLETE (INCLUDES ALL INDENTED PARTS BELOW)	A01111	1	
1	Sample Part	F02222-22	1	
	Sample Subassembly (Includes All Indented Parts Below)	A03333	1	
2	Sample Part (◆ Indicates Part Is Only Available With A03333)	S04444-4	1	◆
	Sample Subassembly (Includes All Indented Parts Below)	K05555	1	
3	Sample Part (◆ Indicates Part Is Only Available With K05555)	M06666	2	◆
4	Sample Part	F07777-77	1	

To Order Parts:

- From the continental U.S., call our toll-free Parts hotline at **1-800-448-7881**. From Europe call our European Headquarters and Manufacturing Facility in Kolo, Poland at **+48-63-2626000** or **+48-3912-1319**. Have your customer number, vehicle identification number, and part numbers ready when you call.
- From other international locations, contact the Wood-Mizer distributor in your area for parts.

3.3 Fuel Tank Assembly

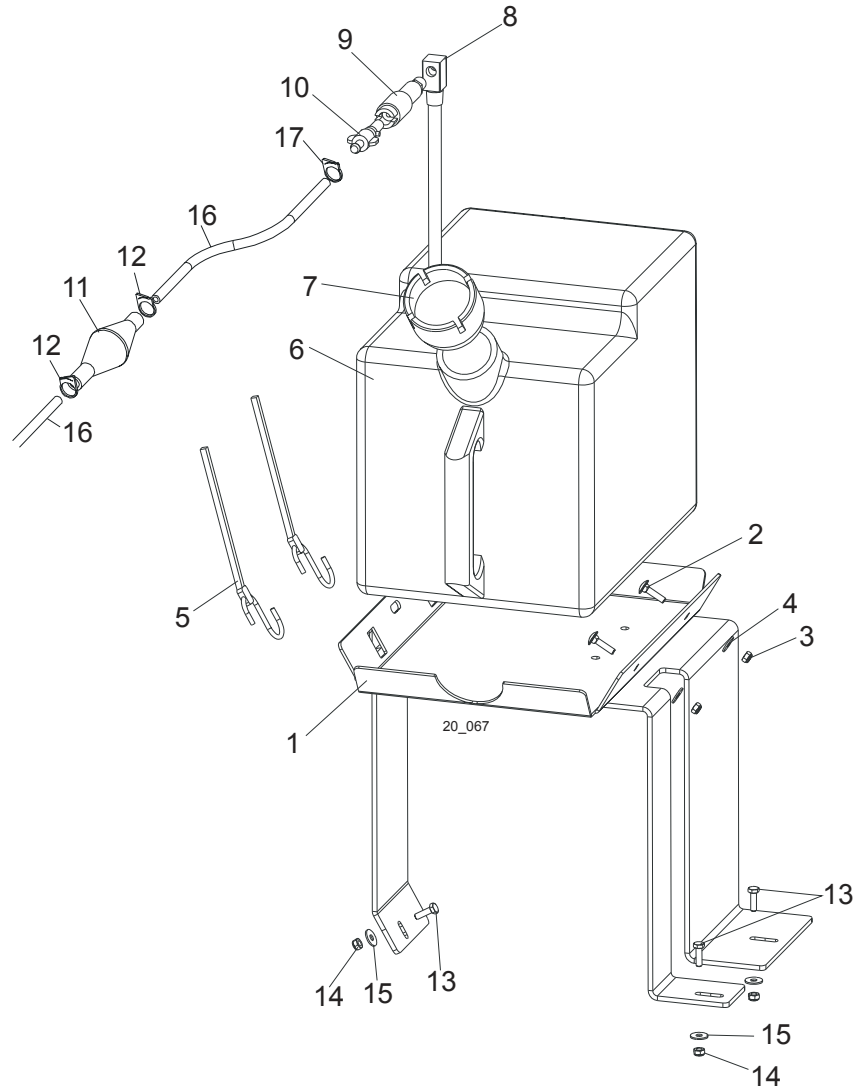

LP.	OPIS (◆ WSKAZUJE CZĘŚCI DOSTĘPNE JEDYNIEM W ZESPOŁACH)	NUMER KAT.	SZT.	
	TANK ASSEMBLY, LT20 SERIES FUEL	092279	1	
1	Tray, LT20 Series Fuel Tank	091885-1	1	
2	Bolt, M6x25-8.8 Carriage Head Zinc	F81001-20	2	
3	Nut, M6-8-B Hex Nylon Zinc Lock	F81031-2	2	
4	Washer, 6.5 Zinc Flat Special	F81053-11	2	
5	Strap, 24" Fuel Tank Rubber	P11258	2	
6	Tank, 5-Gallon Red Fuel	P12167	1	
7	Cap, 3 or 5-Gallon Fuel Tank	P09683	1	
8	Pickup, Fuel	P12172	2	
9	Fitting, 1/4" Plastic Male-Female Disconnect	P12175	1	
10	Fitting, Barb Male Disconnect	P12176	1	
11	Bulb, Fuel Primer	014481	1	◆
12	Clamp, 1/2" OD Fuel Hose	P12374	2	

13	BOLT, M6X20-8.8 HEX HEAD FULL THREAD ZINC	F81001-2	3	
14	NUT, M6-8-B HEX NYLON ZINC LOCK	F81031-2	3	
15	WASHER, 6.5 ZINC FLAT SPECIAL	F81053-11	3	
16	HOSE, 1/4" ID FUEL	R01890-1	2 m	
17	CLAMP, 1/2" OD FUEL HOSE	P12374	1	

3.4 Engine Mount Assembly

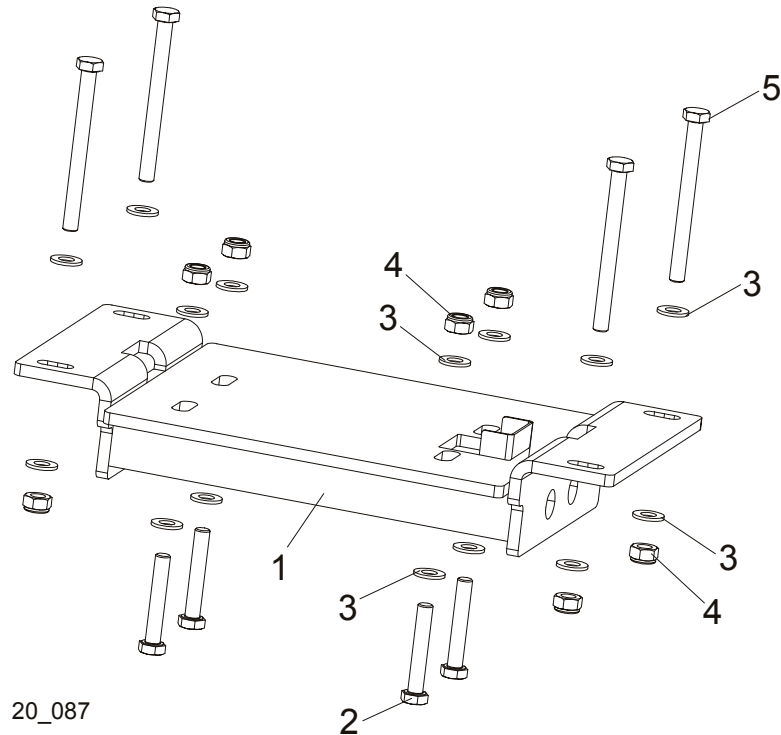

LP.	OPIS (◆ WSKAZUJE CZĘŚCI DOSTĘPNE JEDYNIEM W ZESPOŁACH)	NUMER KAT.	SZT.	
1	MOUNT, G18 ENGINE	092250-1	1	
2	BOLT, M10X60-8.8 HEX HEAD ZINC	F81003-10	4	
3	WASHER, 10.5 ZINC FLAT	F81055-1	16	
4	NUT, M10-8-B HEX NYLON ZINC LOCK	F81033-1	8	
5	BOLT, M10X110 8.8 HEX HEAD ZINC	F81003-43	4	

3.5 Engine Assembly

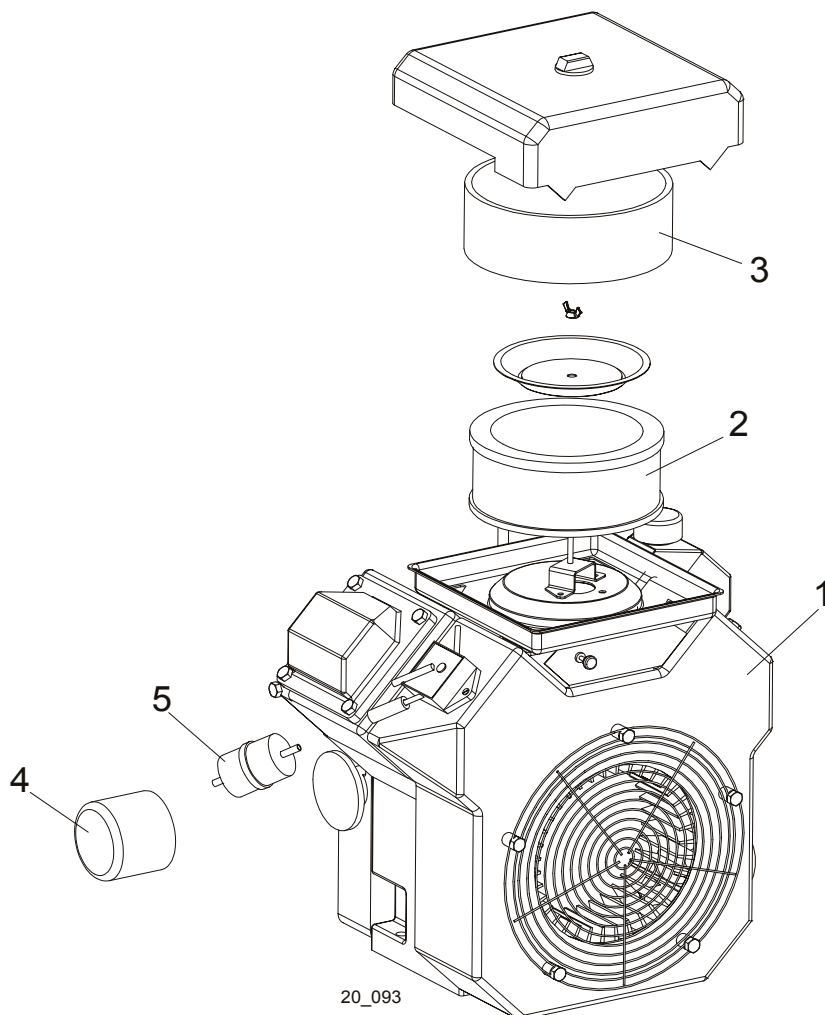

LP.	OPIS (◆ WSKAZUJE CZĘŚCI DOSTĘPNE JEDYNIEM W ZESPOŁACH)	NUMER KAT.	SZT.	
1	ENGINE KIT, KOHLER 18HP BASIC	017622	1	◆
2	Cleaner, Kohler 25HP #24-083-03-S Air	092347	1	◆
3	Pre-Cleaner, Kohler 25HP #24-083-05-S Air	092348	1	◆
	Plug, RC12YC G13/G15 Kohler #12-132-02-S Spark	P12757	2	
4	Filter, Kohler 13/15HP #52-050-02-S Oil	092349	1	
5	Filter, Kohler 25HP #24-050-02-S Fuel	092350	1	

3 Replacement Parts

Muffler Assembly

3.6 Muffler Assembly

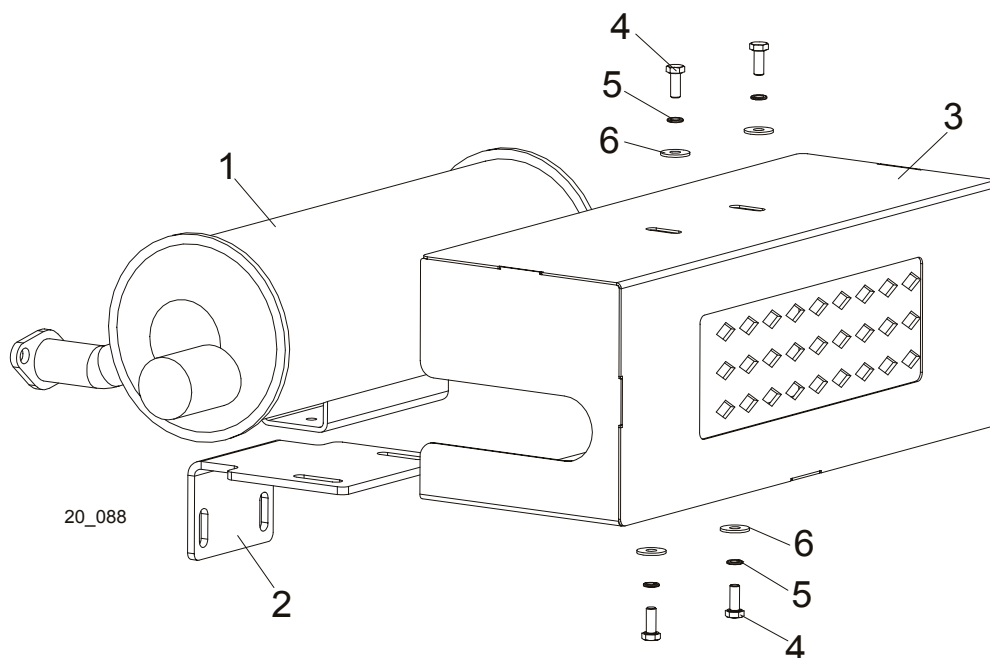

LP.	OPIS (◆ WSKAZUJE CZĘŚCI DOSTĘPNE JEDYNNIE W ZESPOŁACH)	NUMER KAT.	SZT.	
1	MUFFLER, 24068 37-S COMMAND 18	092278	1	
2	BRACKET, G18 MUFFLER MOUNT	092501-1	1	
3	GUARD, GP25/GP18 MUFFLER COMPLETE	091859-1	1	
4	BOLT, M6X16 8.8 HEX HEAD FULL THREAD ZINC	F81001-15	4	
5	WASHER, Z 6.1 SPLIT LOCK ZINC	F81053-3	4	
6	WASHER, 6.5 ZINC FLAT SPECIAL	F81053-11	4	

3.7 Drive Assembly

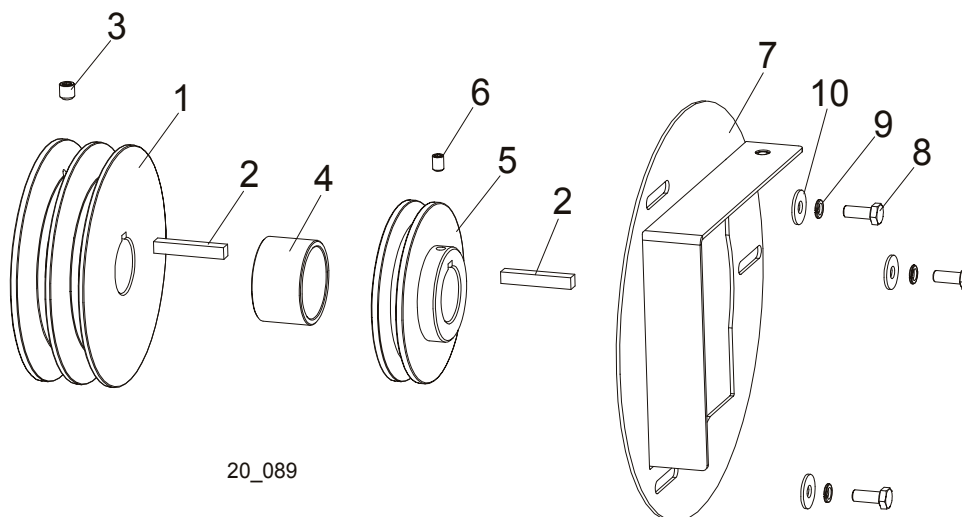

20_089

LP.	OPIS (◆ WSKAZUJE CZĘŚCI DOSTĘPNE JEDYNIEM W ZESPOŁACH)	NUMER KAT.	SZT.	
1	PULLEY, G18 ENGINE	092253	1	
2	KEY, 6.35 X 6.36 X 40	S04124	2	
3	SCREW, M8X8-33H FLAT POINT HEX SOCKET SET ZINC	F81014-1	1	
4	BUSHING, SPACER	092254-1	1	
5	PULLEY, Z95/28.575	092551	1	
6	SCREW, M6X8 CONE POINT HEX SOCKET SET ZINC	F81013-1	1	
7	GUARD, G18 ALTERNATOR DRIVE PULLEY	092603-1	1	
8	BOLT, M6X16 8.8 HEX HEAD FULL THREAD ZINC	F81001-15	3	
9	WASHER, Z 6.1 SPLIT LOCK ZINC	F81053-3	3	
10	WASHER, 6.5 ZINC FLAT SPECIAL	F81053-11	3	
	V-BELT, BX83 1/2	088110	2	

3.8 Throttle Cable Assembly

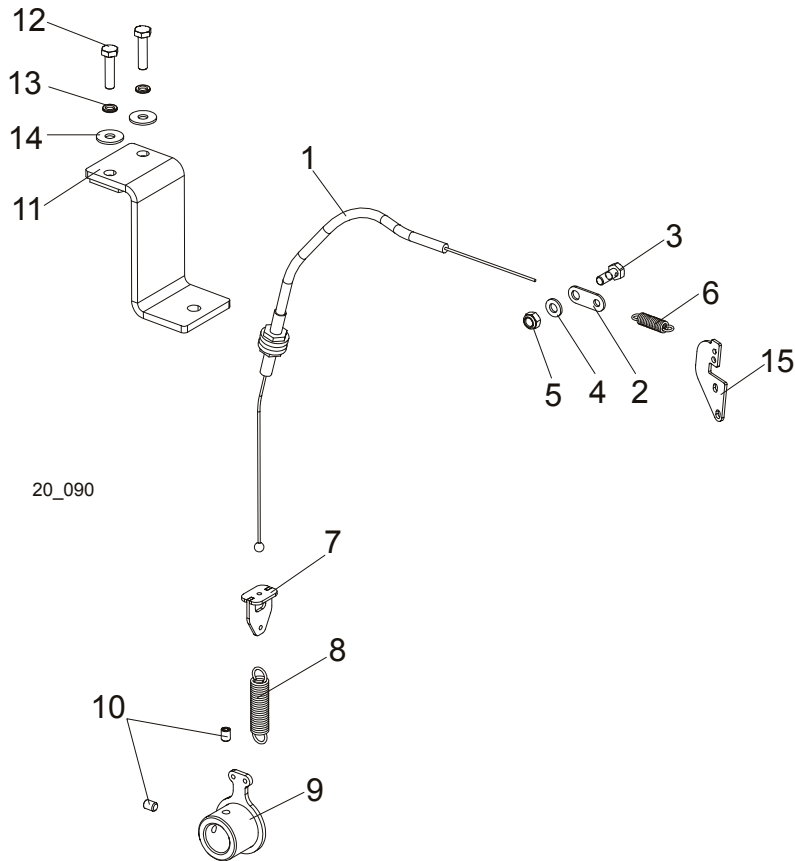

LP.	OPIS (♦ WSKAZUJE CZĘŚCI DOSTĘPNE JEDYNIEM W ZESPOŁACH)	NUMER KAT.	SZT.	
	CABLE, G18 THROTTLE COMPLETE	092550	1	
1	Cable, G18 Throttle	092259	1	
2	Plate, G18 Throttle Cable Spring Mount Zinc	092531-1	1	
3	Bolt, Throttle Cable Clamp Zinc	088120-1	1	
4	Washer, 6.4 Flat Zinc	F81053-1	1	
5	Nut, M6-8-B Hex Nylon Zinc Lock	F81031-2	1	
6	Spring, 1.3 x 8 x 20 Extension	092549	1	
7	Bracket, Throttle Cable Spring Mount	091918-1	1	
8	Spring, 1.6x12x38 Extension	092208	1	
9	BRACKET, G18 THROTTLE/TENSIONER HANDLE	092535-1	1	
10	SCREW, M6X8 CONE POINT HEX SOCKET SET ZINC	F81013-1	2	
11	BRACKET, G18 THROTTLE CABLE MOUNT	092532-1	1	
12	BOLT, M6X25-5.8 HEX HEAD FULL THREAD ZINC	F81001-3	2	
13	WASHER, Z 6.1 SPLIT LOCK ZINC	F81053-3	2	
14	WASHER, 6.5 ZINC FLAT SPECIAL	F81053-11	2	
15	BRACKET, G25 THROTTLE	091565-1	1	

3.9 Alternator Assembly

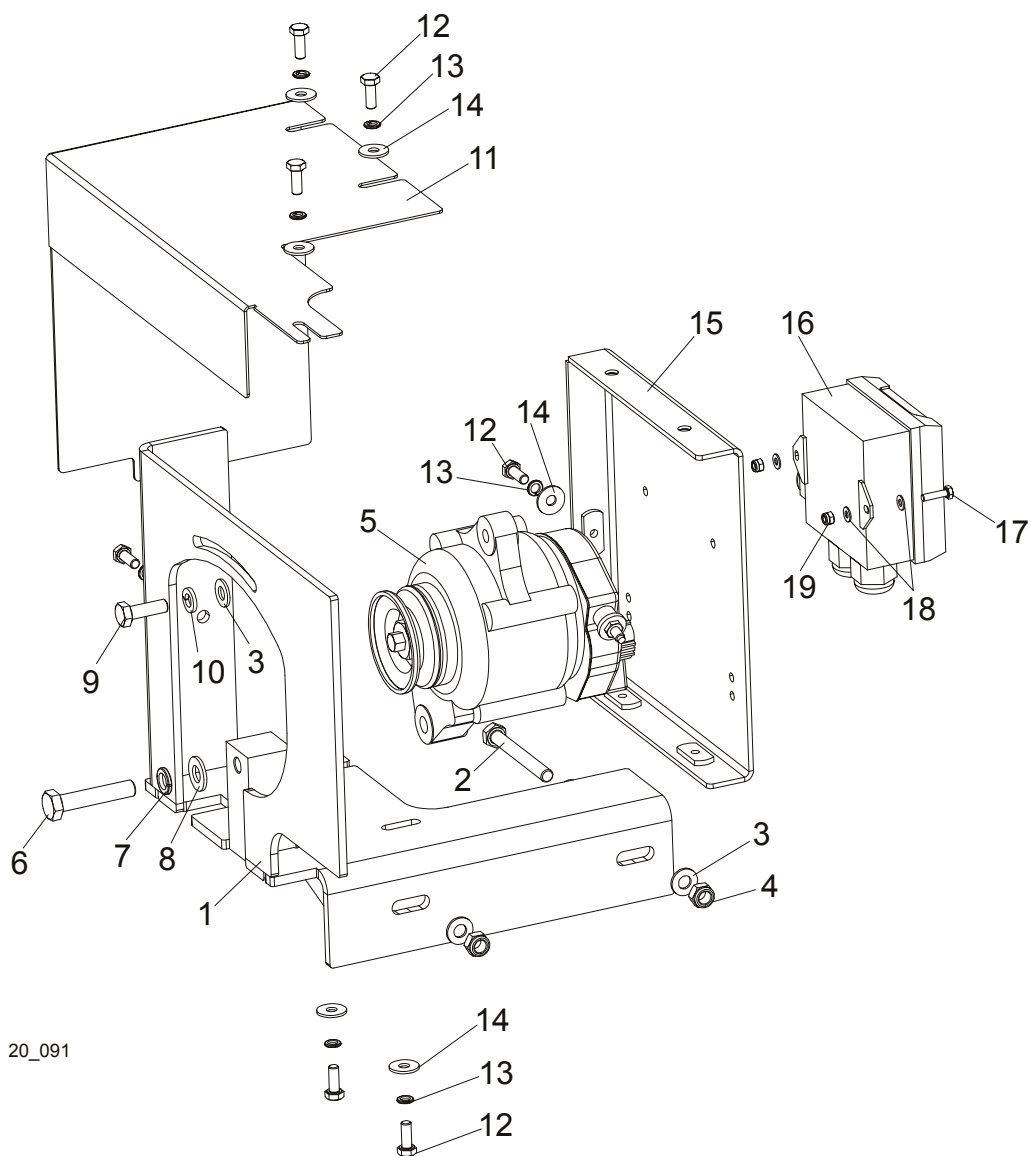

20_091

LP.	OPIS (◆ WSKAZUJE CZĘŚCI DOSTĘPNE JEDYNIEM W ZESPÓŁACH)	NUMER KAT.	SZT.	
1	BRACKET, G18 ALTERNATOR MOUNT	092563-1	1	
2	BOLT, M8X70 8.8 HEX HEAD ZINC	F81002-71	2	
3	WASHER, 8.4 ZINC FLAT	F81054-1	5	
4	NUT, M8-8-B HEX NYLON ZINC LOCK	F81032-2	2	
5	ALTERNATOR, D42	089661	1	
6	BOLT, M10X50-8.8 HEX HEAD FULL THREAD ZINC	F81003-4	1	
7	WASHER, 10.2 SPLIT LOCK ZINC	F81055-2	1	
8	WASHER, 10.5 ZINC FLAT	F81055-1	1	
9	BOLT, M8X25-8.8-B HEX HEAD FULL THREAD ZINC	F81002-5	1	
10	WASHER, 8.2 SPLIT LOCK ZINC	F81054-4	1	
11	GUARD, G18 ALTERNATOR UPPER	092606-1	1	

3**Replacement Parts***Alternator Assembly*

12	BOLT, M6X16 8.8 HEX HEAD FULL THREAD ZINC	F81001-15	7	
13	WASHER, Z 6.1 SPLIT LOCK ZINC	F81053-3	7	
14	WASHER, 6.5 ZINC FLAT SPECIAL	F81053-11	7	
15	MOUNT, G18 SAFETY SWITCH RELAY	092533-1	1	
16	RELAY, G18/25 SAFETY SWITCH	092284	1	
17	BOLT, M4X16 5.8 HEX HEAD FULL THREAD ZINC	F81011-6	2	
18	WASHER, 4.3 ZINC FLAT	F81051-2	4	
19	NUT, M4-B HEX NYLON ZINC LOCK	F81029-1	2	
	V-BELT, HZ LP=800	092602	1	

SECTION 4 ELECTRICAL INFORMATION

4.1 Electrical Wiring Diagram, G18 Engine

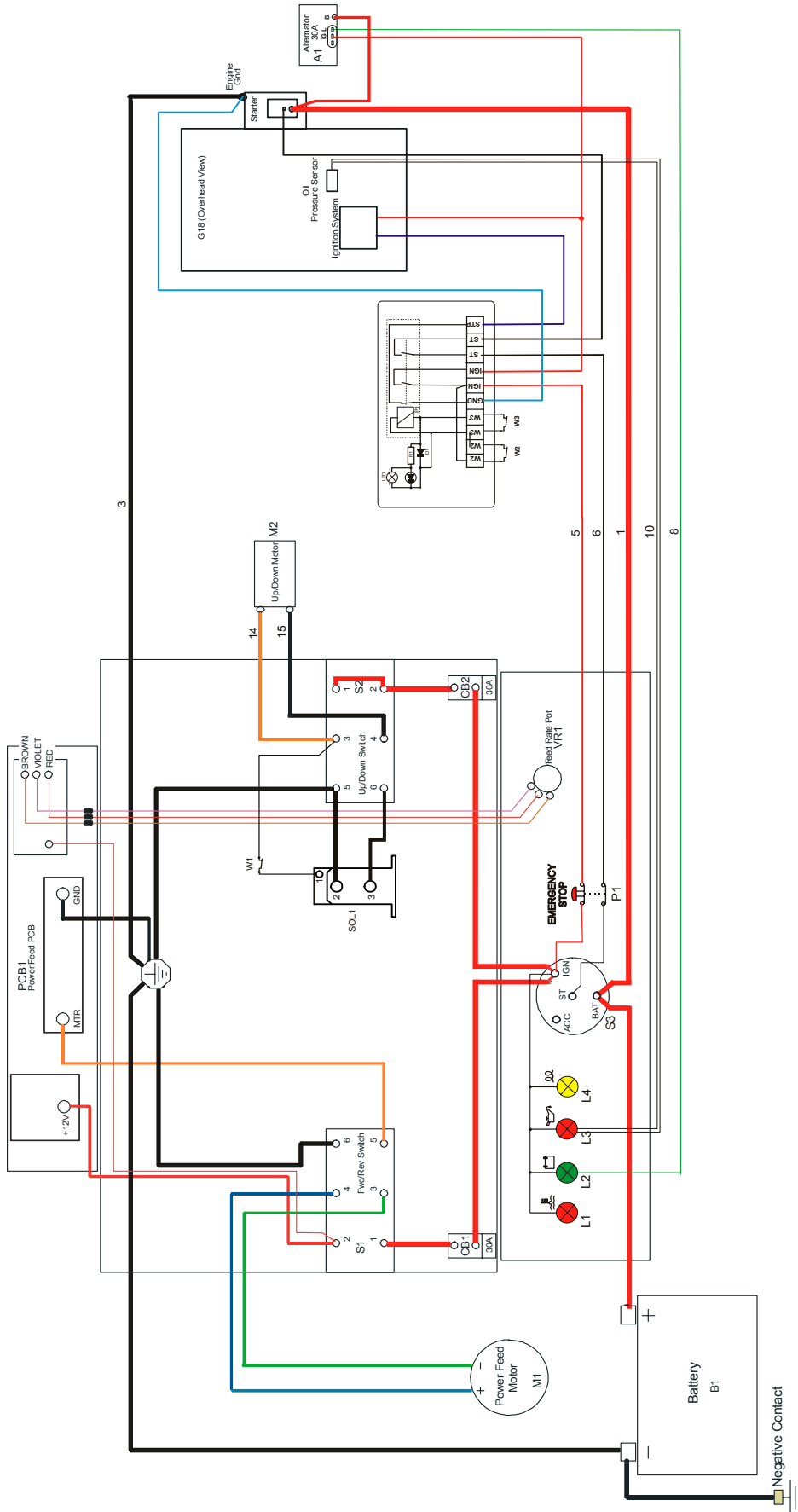

FIG. 5-0 G18 ELECTRICAL WIRING DIAGRAM

4.2 Electrical Components, G18-20S

Item	Manufacturer	WM Part #	Description
S1, S2	Square D	E20438	Drum Switch, '92 EURO Power Feed
B1	BANNER	090999	Battery, 12V 50Ah ENERGY BULL BA50
CB1, CB2	SCHNEIDER ELECTRIC	024246	Breaker, 30 Amp Manual Reset Panel Mount
PCB1	WMP	024396-1	Module, Power Feed Control
S3	General	P04350	Key Switch
SOL1		P10449	Solenoid, 120-943 12V DC
PK1		086486	Relay, Safety Key Switches
VR1		E20519	Potentiometer, 1K Feed Rate
M1,M2		P04140	Motor, 12V 0.5HP Up/Down
P1	SCHNEIDER ELECTRIC	086556	Switch, XB4 BS542 Emergency Stop
L1, L3	Elbok	090998	Control Light, KLA-RS-10-2
L2	Elbok	091051	Control Light, KLA-GS-10-2
L4	Elbok	091456	Control Light, KLA-RS-10-2
W2	HONEYWELL	087650	Limit Switch, GKMC03W2
W3	HONEYWELL	091742	Limit Switch, EVN2000A (Saw Head Loading Position)
W1	HONEYWELL	089816	Limit Switch, EVN2000C (Maximum Saw Head Height)

TABLE 4-1