

E11 & E15

Electric Option

Safety, Operation, Maintenance & Parts Manual

LT20 Series

Rev. D6.00



Safety is our #1 concern! Read and understand all safety information and instructions before operating, setting up or maintaining this machine.

April 2003

Form #616

Table of Contents

Section-Page

SECTION 1	SAFETY & GENERAL INFORMATION	1-1
1.1	Motor Operation	1-1
1.2	Electrical Diagrams	1-2
SECTION 2	OPERATION	2-1
2.1	Starting The Motor	2-1
2.2	Blade Rotation Change.....	2-1
SECTION 3	MAINTENANCE	3-1
3.1	Drive Belt	3-1
SECTION 4	REPLACEMENT PARTS	4-1
4.1	How To Use The Parts List	4-1
4.2	Sample Assembly	4-1
4.3	Motor Starter Box Assembly.....	4-2
4.4	Electric Motor Assembly.....	4-3
4.5	Power Cord Bracket	4-4
SECTION 5	DC ELECTROMAGNETIC BRAKE	5-1
5.1	Design and Principle of Operation	5-1
5.2	Service	5-2

SECTION 1 SAFETY & GENERAL INFORMATION



This symbol calls your attention to instructions concerning your personal safety. Be sure to observe and follow these instructions. This symbol accompanies a signal word. The word **DANGER** indicates an imminently hazardous situation which, if not avoided, will result in death or serious injury. **WARNING** suggests a potentially hazardous situation which, if not avoided, could result in death or serious injury. **CAUTION** refers to potentially hazardous situations which, if not avoided, may result in minor or moderate injury to persons or equipment. Read all safety instructions before operating this equipment and observe all safety warnings!

Read all safety instructions before operating this equipment and observe all safety warnings! Read the manufacturer's operation manual and observe any additional safety warnings applicable to the specific make and model you have purchased.

1.1 Motor Operation



DANGER! Always be sure the blade is disengaged and all persons are out of the path of the blade before starting the engine or motor. Failure to do so will result in serious injury.



WARNING! Hazardous voltage inside the disconnect box, starter box, and at the electric motor can cause shock, burns, or death. Disconnect power supply before servicing!

WARNING! Do not for any reason adjust the engine drive belts or belt support bracket with the engine running. Doing so may result in serious injury.

WARNING! Remove the blade before performing any engine service. Failure to do so may result in serious injury.

WARNING! Always wear proper and necessary safety equipment when performing service functions. Proper safety equipment includes eye protection, breathing protection, hand protection and foot protection.



IMPORTANT! Make sure the power cords are free to travel the length of the machine. An overhead boom system to keep the cords off of the floor is recommended.

1.2 Electrical Diagrams

See Table 1-1. The motor options available for the LT20 Series sawmills are listed below.

Engine/Motor Type	Manufacturer	Model No.	Power	Other Specifications
11HP Electric	Tamel SA, Poland	Sg 132S-2B HM	7,5 kW	14,7 A, 2925 RPM
15HP Electric	Tamel SA, Poland	Sg 132S-2PC HM	11 kW	22,3 A, 2920 RPM

TABLE 1-1

All the motors mentioned above are 2900-2920 RPM motors, 380V, 50Hz. They all have IP54 safety class, and -F isolation class.

The motor is powered through the starter box by the main switch, which along with 32A connector and plug, is located on the front of the starter box. Use only OW 5 x 2,5 mm² supplying wire or 5 x 4 mm² if the distance between the power source and working sawmill is large.

Attach the special arm, provided with the sawmill, to the mast, then hang the supplying wire that powers the starter box. The arm secures the operator and allows him to operate the sawmill safely.



DANGER! The starter box is always under hazardous voltage. Before opening the front door of the starter box, unplug the main connector to disconnect the power supply!

Make sure that at least once a year or after any repair a qualified electrician checks the installation on resistance and anti-shock security system.

Make sure the starter box is dust-free. Disconnect the power from time to time and clean inside of the box to remove any dust or wood chips. Do not operate or store with starter box door open.



DANGER! Hazardous voltage inside the starter box can cause shock, burns, or death. Disconnect the power supply before servicing.

See Figure 1-1. The E11 & E15 motor starter box wiring diagram is shown below.

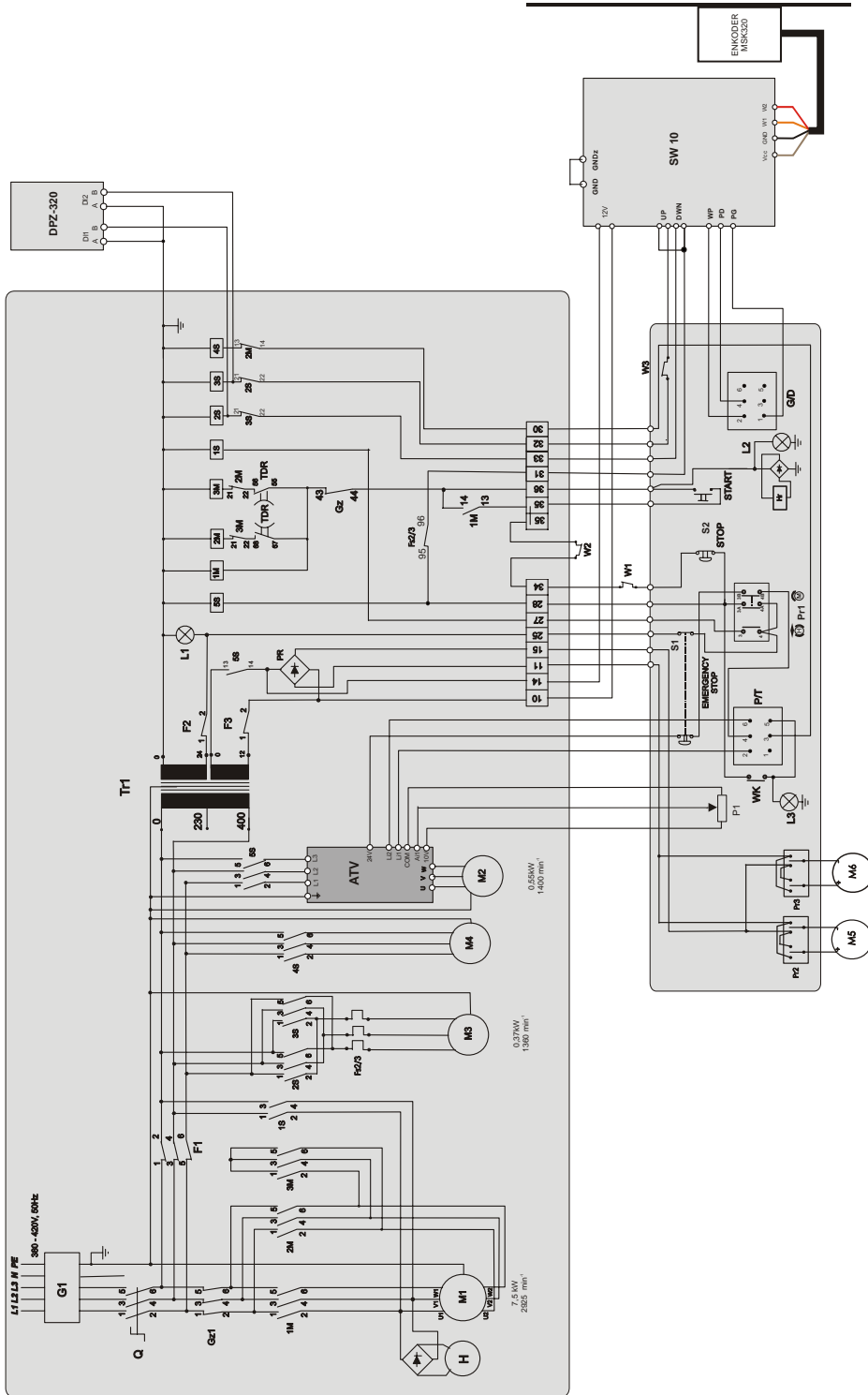

FIG. 1-1

1 Safety & General Information

Electrical Diagrams

See Figure 1-2. The E11 & E15 motor starter box wiring diagram is shown below (Norwegian version).

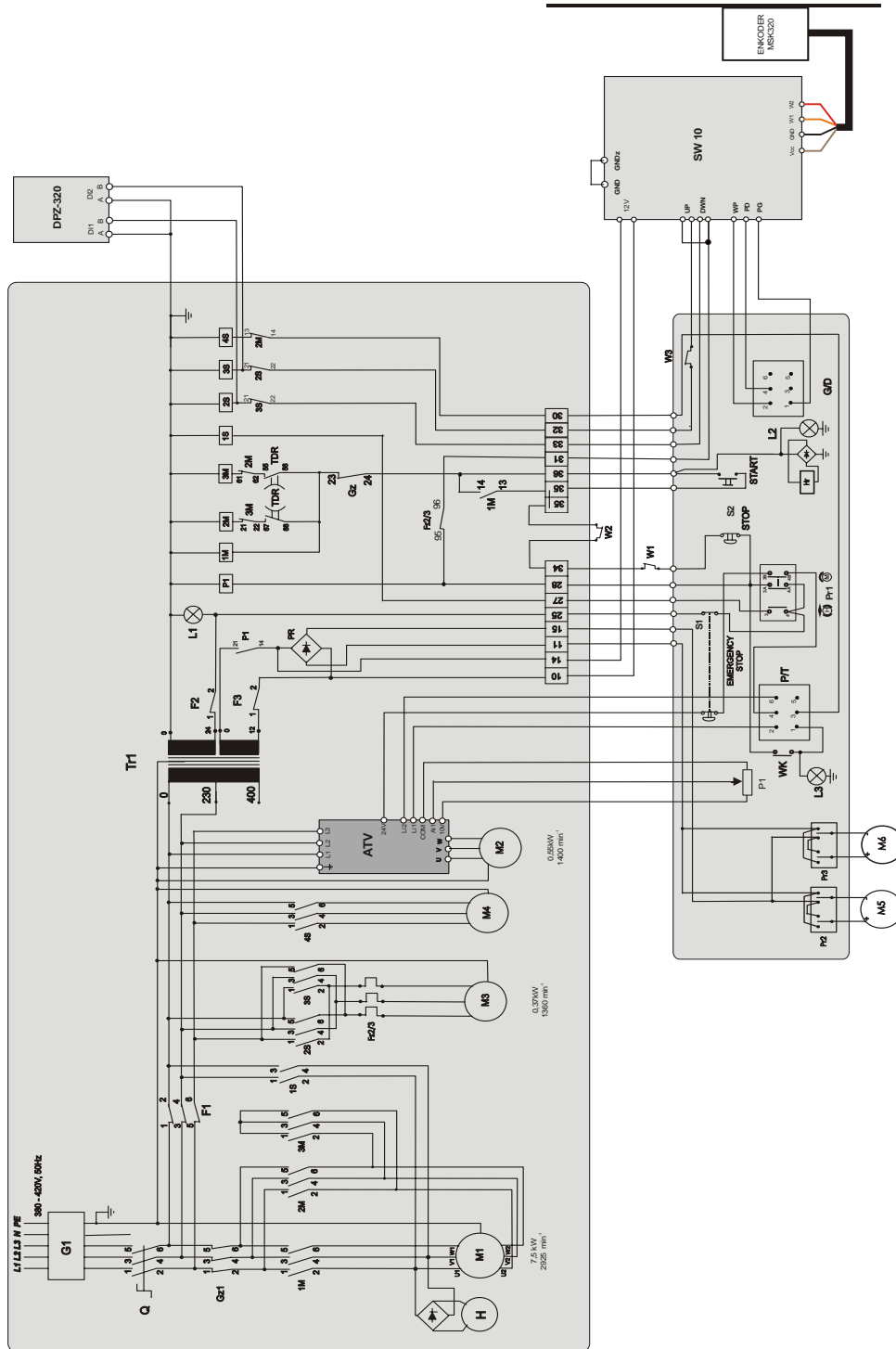

FIG. 1-2

See Figure 1-3. The E11 & E15 motor starter box wiring diagram is shown below. (Wireless option)

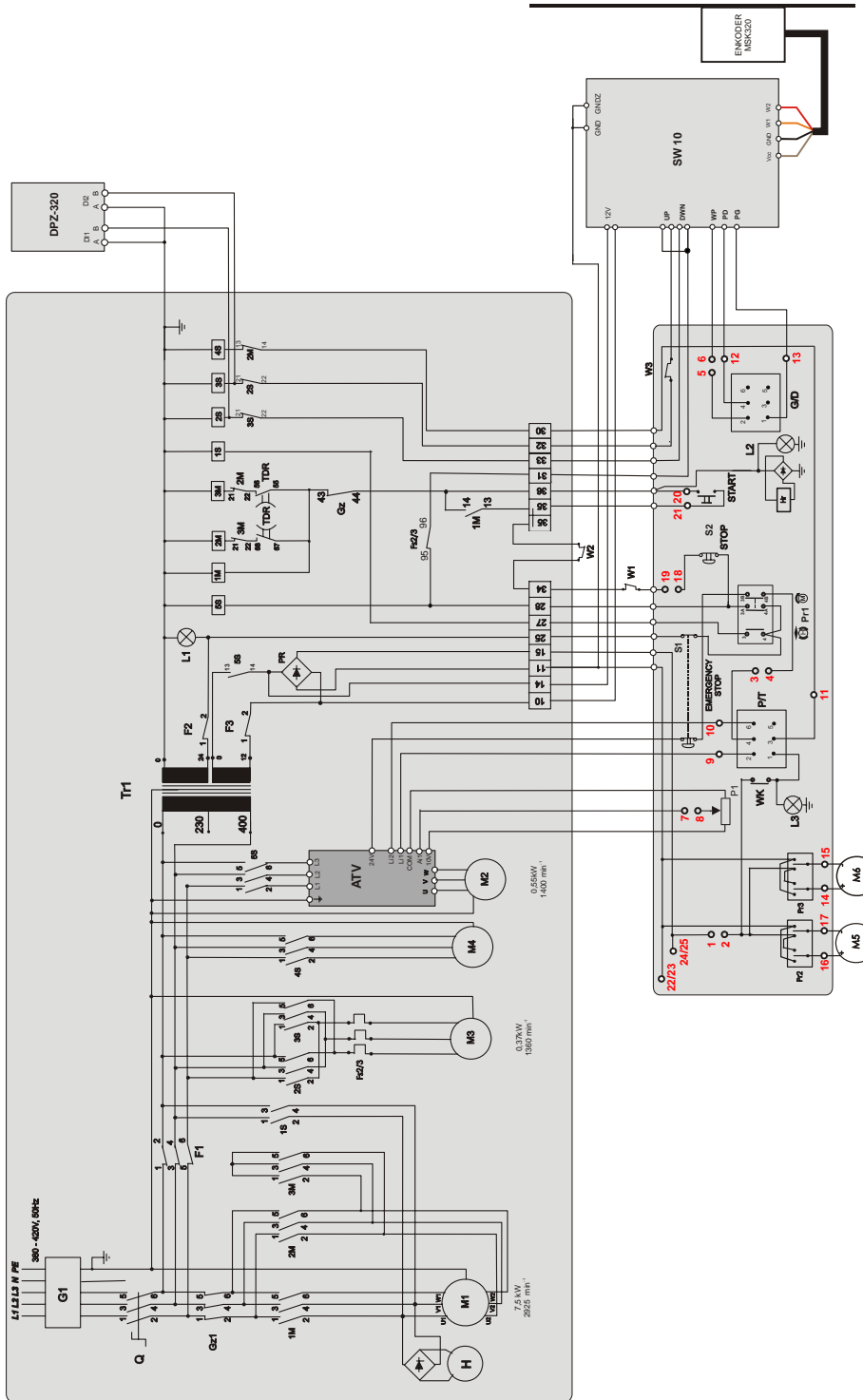

FIG. 1-3

The description of the diagram shown in **Figure 1-2**.

Ref.	Symbol	Description	Manufacturer	Syteline No.
1.	Q	Main Switch, ABB OT32 E3	ABB	088265
2.	Gz1	Motor Switch, Gz1 M21	SCHNEIDER ELECTRIC	084330
3.	1M, 2M	Contactor, LC1 D18 B7	SCHNEIDER ELECTRIC	084306
4.	3M	Contactor, LC1 D09B7	SCHNEIDER ELECTRIC	084305
5.	1S	Contactor, LC1 D0610B7	SCHNEIDER ELECTRIC	084308
6.	2S, 3S	Contactor, LC1 D0610B7	SCHNEIDER ELECTRIC	084309
7.	Fs2/3	Time Relay, LR2K 0308	SCHNEIDER ELECTRIC	084312
8.	F1	Circuit Breaker, C60N C3P 6A 24348	SCHNEIDER ELECTRIC	091554
9.	F2	Circuit Breaker, C60N 2A 24396	SCHNEIDER ELECTRIC	088278
10.	F3	Circuit Breaker, C60N 6A 24396	SCHNEIDER ELECTRIC	095842
11.	TR1	Transformer, TMM63/A 240/380/415/24	BREVE	088279
12.	TDR1	Time Relay, LAD S2	SCHNEIDER ELECTRIC	084037
13.	L1	Control Light, M22 LED24V White	MOELLER	090448
14.	Gz	Auxiliary Contact, GZ1 - AN11	SCHNEIDER ELECTRIC	091611
15.	ATV	Speed Controller, ATV31HU11N4	SCHNEIDER ELECTRIC	093488
		Speed Controller, ATV31H075M3X (for Norwegian version)	SCHNEIDER ELECTRIC	100261
16.	M1	Blade Motors, Sg132S - 2B HM	TAMEL	090993
17.	W1	Safety Key Switch, GKMC03W2	HONEYWELL	087650
18.	W2	Loading Position Limit Switch EVN2000A	HONEYWELL	091742
19.	W3	Saw Head Maximum Height Switch, GLCB01C	HONEYWELL	100910

20.	S1	Emergency Stop Switch, XB4 BS542	SCHNEIDER ELECTRIC	086556
21.	S2	START-STOP Button M22 DDL-GR-X1/X0/K11/230-W	MOELLER	090452
22.	Pr1	Key Switch, M22-WRS3 Contact, M22-K10 (2)	MOELLER	091361 091362
23.	M2	Motor, Skh71X-4C2	BESEL	091186
24.	M3	Motor, Skh 71-4B2	BESEL	091304
25.	P/T	Switch, US 1992 Pwr/Feed (Service Package)	SCHNEIDER ELECTRIC	E20439
26.	G/D	Switch, 1992 Up/Down (Service Package)	SCHNEIDER ELECTRIC	E20440
27.	P1	Relay RM84 2012-35-1024	RELPOL	090515

SECTION 2 OPERATION

2.1 Starting The Motor



DANGER! Always be sure all persons are away from the blade before starting the motor.

DANGER! Push the emergency switch located on the LT20 control box, to stop the sawmill immediately.

LT20 Series

Turn on the main switch to start the motor. When the power is on the white control light located on the box door comes on. When all covers are closed white “ready” control light comes on.

2.2 Blade Rotation Change

Make sure the blade rotation is correct as shown in the motor housing after starting an electric motor sawmill.

Turn off the blade motor using the “Stop” switch located on the front of the control box. Disconnect the starter box using the main switch, and disconnect the plug located on the left side of the starter box.

Then, with the screwdriver turn the phase converter switch (red switch at the bottom of the connector) to the right or to the left, and rotate it about 180° - this converts the phases and changes the blade rotation.

SECTION 3 MAINTENANCE

 **This symbol** identifies the interval (hours of operation) which each maintenance procedure should be performed. "AR" signifies maintenance procedures which should be performed as required.

3.1 Drive Belt

 Periodically check all belts for wear. Replace any damaged or worn belts as needed.

 Adjust the drive belt support as needed. The drive belt support is designed to extend belt life.

 **DANGER!** Do not for any reason adjust the drive belt support with the motor running. Always stop the motor before reaching or looking into the drive belt area.

SECTION 4 REPLACEMENT PARTS

4.1 How To Use The Parts List

- Use the table of contents or the index to locate the assembly that contains the part you need.
- Go to the appropriate section and locate the part in the illustration.
- Use the number pointing to the part to locate the correct part number and description in the table.
- Parts shown indented under another part are included with that part.
- Parts marked with a diamond (◆) are only available in the assembly listed above the part.

See the sample table below. Sample Part #A01111 includes part F02222-2 and subassembly A03333. Subassembly A03333 includes part S04444-4 and subassembly K05555. The diamond (◆) indicates that S04444-4 is not available except in subassembly A03333. Subassembly K05555 includes parts M06666 and F07777-77. The diamond (◆) indicates M06666 is not available except in subassembly K05555.

4.2 Sample Assembly				
REF	DESCRIPTION (◆ Indicates Parts Available In Assemblies Only)	PART #	QTY.	
	SAMPLE ASSEMBLY, COMPLETE (INCLUDES ALL INDENTED PARTS BELOW)	A01111	1	
1	Sample Part	F02222-22	1	
	Sample Subassembly (Includes All Indented Parts Below)	A03333	1	
2	Sample Part (◆ Indicates Part Is Only Available With A03333)	S04444-4	1	◆
	Sample Subassembly (Includes All Indented Parts Below)	K05555	1	
3	Sample Part (◆ Indicates Part Is Only Available With K05555)	M06666	2	◆
4	Sample Part	F07777-77	1	

To Order Parts:

- From Europe call our European Headquarters and Manufacturing Facility in Kolo, Poland at **+48-63-2626000**. From the continental U.S., call **1-800-448-7881** to order parts. Have your customer number, vehicle identification number, and part numbers ready when you call.
- From other international locations, contact the Wood-Mizer distributor in your area for parts.

4.3 Motor Starter Box Assembly



REF	DESCRIPTION (◆ Indicates Parts Available In Assemblies Only)	PART #	QTY.	
	STARTER ASSEMBLY, LT20 11HP & 15HP 3-PHASE 50HZ ELECTRIC MOTOR	096017	1	
	BOX, LT20 AC ELECTRIC (NORWAY)	096017-2	1	
	CABLE, OLFLEX CLASSIC 400P 12G2,5	R80585-52	2.1m	
	CABLE GLAND, PG21 1060.21 BRASS	F81096-5	1	

4 Replacement Parts

Electric Motor Assembly

4.4 Electric Motor Assembly

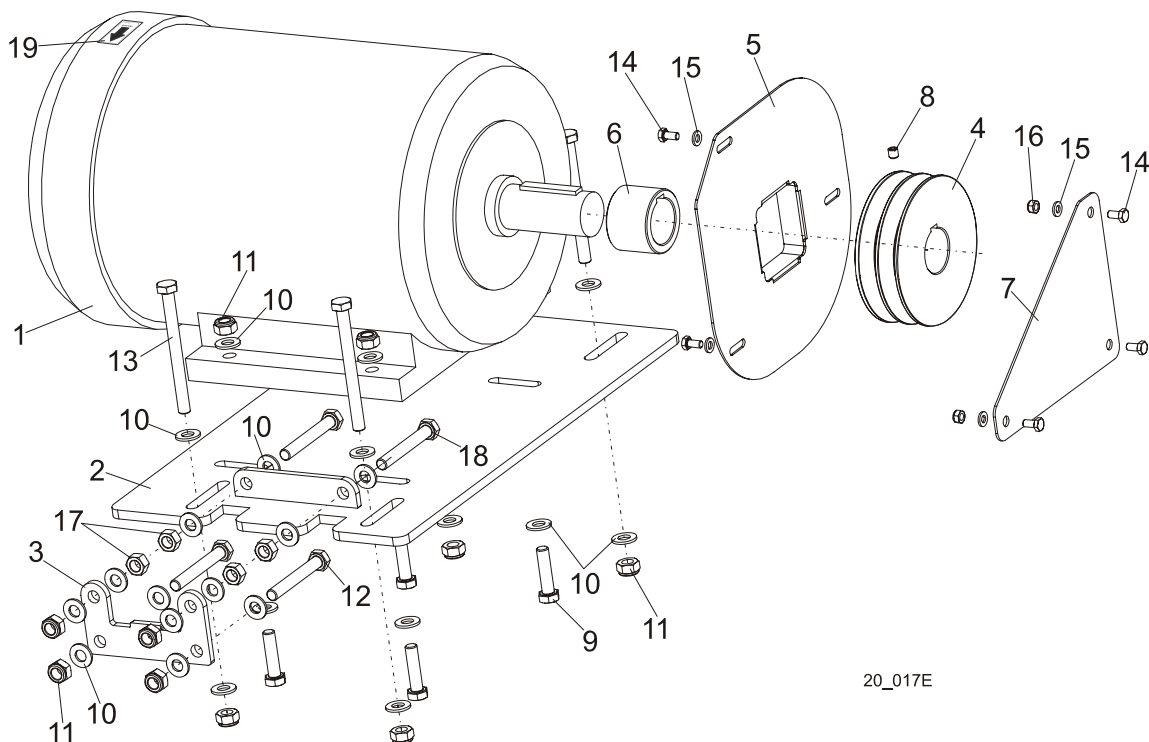

20_017E

REF	DESCRIPTION (◆ Indicates Parts Available In Assemblies Only)	PART #	QTY.
1	MOTOR, 11kW PSSg-132S -2 HM+132	089049	1
2	MOUNT WELDMENT, E15 ELECTRIC MOTOR COMPLETE	097927-1	1
3	PLATE, BELT TENSIONER	097821-1	1
4	PULLEY, E15 MOTOR	091560	1
5	GUARD, E15 SHAFT	100908-1	1
6	BUSHING, E15 MOTOR MOUNT	091639-1	1
7	PLATE, MOUNTING CAP	094247-1	1
8	SCREW, SET,M8x8-33H FE/ZN HEX SCKT HEAD	F81014-1	1
9	BOLT, M10x40-8.8 ZINC	F81003-16	4
10	WASHER, M10 FLAT ZINC	F81055-1	26
11	NUT, M10 NYLON HEX ZINC LOCK	F81033-1	8
12	BOLT, M10x75-8.8 ZINC	F81003-15	4
13	BOLT, M10x110-8.8 ZINC	F81003-43	4
14	BOLT, M6x12-8.8 HEX HEAD ZINC	F81001-7	6
15	WASHER, M6 FLAT ZINC	F81053-1	6
16	NUT, M6 HEX NYLON LOCK ZINC	F81031-2	3
17	NUT, M10-8-B-FE	F81033-3	4
18	BOLT, M10x100-8.8 ZINC	F81003-91	2
19	DECAL, 2925 RPM MOTOR ROTATION DIRECTION	S20097F	1

4.5 Power Cord Bracket

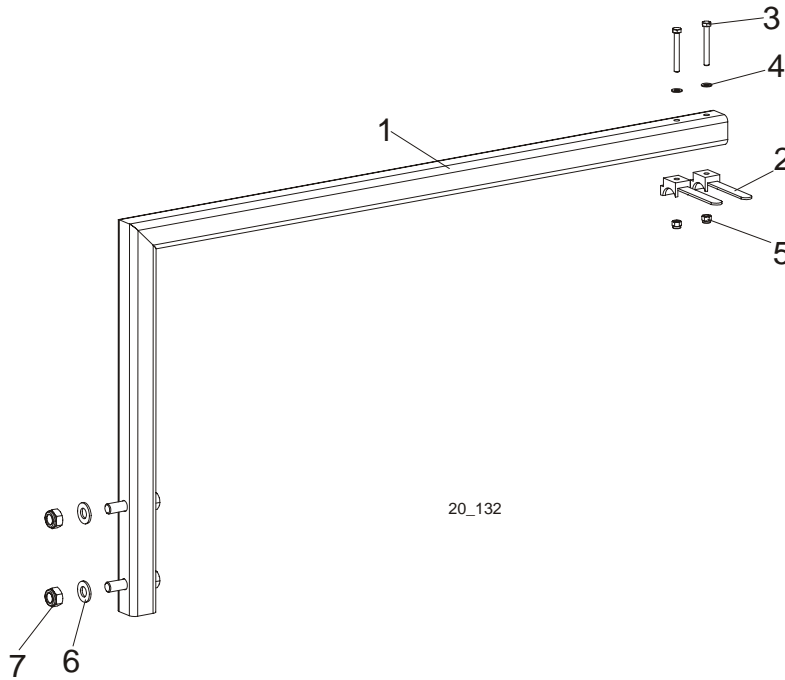

REF	DESCRIPTION (◆ Indicates Parts Available In Assemblies Only)	PART #	QTY.	
	BRACKET, LT20 POWER CORD COMPLETE	091599	1	
1	Bracket, LT20 Power Cord	091598-1	1	
2	Holder, Cable Plastic Tie	F81082-1	2	
3	Bolt, M5x40-8,8 Hex Head	F81000-11	2	
4	Washer, M5 Flat Zinc	F81052-1	2	
5	Nut, M5-8 Nylon Lock Zinc	F81030-2	2	
6	WASHER, M10 FLAT ZINC	F81055-1	2	
7	NUT, M10 NYLON HEX ZINC LOCK	F81033-1	2	

SECTION 5 DC ELECTROMAGNETIC BRAKE

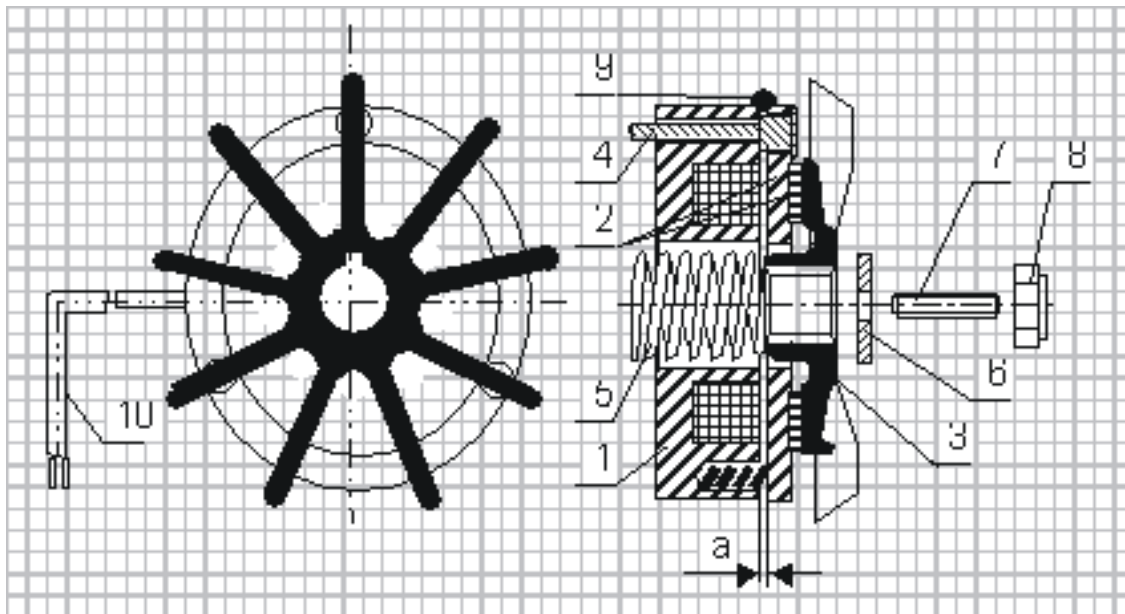

- 1 - Electromagnet,
- 2 - Armature complete with brake linings,
- 3 - Fan,
- 4 - Retaining bolt
- 5 - Central spring,
- 6 - Special washer,
- 7 - Set screw,
- 8 - Self-locking nut,
- 9 - Sealing ring,
- 10 - Output cable.

5.1 Design and principle of operation

The DC electromagnetic brake type H consists of 3 main subassemblies:

- electromagnet (1),
- armature complete (2)
- cast iron fan (3).

Electromagnet (1) energised: The DC voltage from the motor applied via the rectifying circuit causes the attraction of the armature (2) releasing the brake and thus the fan (3) is free to rotate.

Electromagnet (1) de-energised: The electromagnet stops to attract the armature (2) and spring presses the armature with brake linings (2) against the fan and the brake is thus applied.

5.2 Service

During normal operation and at the routine inspections verify the air gap and check if all screws are tight. In case when any symptoms of inefficient braking are observed, then use the self-locking nut (8) to re-adjust the air gap to the value corresponding to Table 1.

Such readjustment may be repeated until the brake linings are completely worn out. When this will occur, a complete armature with brake linings (2) must be replaced.

If the air gap of the brake is correctly adjusted and despite of it the brake does not operate properly (the brake fails to release), it may be caused by:

- the electromagnet (1): burned coil or defected output cable (10),
- rectifying circuit (installed in the electric motor terminal box).

The above mentioned subassemblies should be checked and defected part replaced.

Table 1:

TYPE	H-63	H-71	H-80	H-90	H-100	H-112	H-132	H-160
Nominal Gap „a”	0.2 ±0,05	0.2 ±0,05	0.2 ±0,05	0.2 ±0,05	0.2 ±0,1	0.2 ±0,1	0.2 ±0,1	0.2 ±0,1