

Wood-Mizer®

Parts Manual

LT20 Series AC MH

rev. D5.00

LT20 Series DC MH

rev. D4.00



Safety is our #1 concern! Read and understand all safety information and instructions before operating, setting up or maintaining this machine.

April 2003

Form #615

Table of Contents

Section-Page

SECTION 1	GENERAL INFORMATION	1-1
1.1	How To Use The Parts List	1-1
1.2	Sample Assembly	1-1
SECTION 2	BLADE GUIDE ROLLERS & ARM	2-1
2.1	Blade Guide Assembly, Idle Side.....	2-1
2.2	Blade Guide Assembly, Drive Side.....	2-2
2.3	Blade Guide Arm & Rollers.....	2-3
2.4	Blade Guide Arm Drive Assembly.....	2-4
SECTION 3	BLADE WHEELS & TENSIONER	3-1
3.1	Blade Wheel Assembly, Drive Side.....	3-1
3.2	Blade Wheel Assembly, Idle Side.....	3-2
3.3	Blade Tensioner Assembly.....	3-3
SECTION 4	SAW HEAD	4-1
4.1	Middle Throat Screw.....	4-1
4.2	Drive Belt Tensioner, DC Sawmills.....	4-1
4.3	Water Lube Assembly.....	4-3
4.4	LT20AC Saw Head Decals.....	4-4
4.5	LT20DC Saw Head Decals.....	4-6
4.6	Blade Housing Cover.....	4-8
4.7	Control Box (AC Sawmills).....	4-10
4.8	Control Box (DC Sawmills).....	4-12
4.9	Drum Switches.....	4-14
4.10	Sawdust Chute.....	4-15
4.11	Up/Down Cable Chain Assembly.....	4-16
SECTION 5	UP/DOWN ASSEMBLY	5-1
5.1	Up/Down Assembly, AC Mills.....	5-1
5.2	Up/Down Assembly, DC Mills.....	5-3
5.3	Up/Down Chain Tensioner Assembly.....	5-5
5.4	Battery Box Assembly, DC Mills.....	5-6
SECTION 6	UP/DOWN ROLLERS & BLADE HEIGHT SCALE	6-1
6.1	Up/Down Rollers.....	6-1
6.2	Blade Height Scale.....	6-3
6.3	Limit Switches.....	6-5

Table of Contents

Section-Page

SECTION 7	POWER FEED & TRACK ROLLERS	7-1
7.1	Power Feed Assembly, AC Mills	7-1
7.2	Power Feed Assembly, DC Mills	7-3
7.3	Upper Track Rollers And Wipers	7-5
7.4	Lower Track Rollers	7-7
SECTION 8	BED FRAME ASSEMBLY	8-1
8.1	Bed Rail Assembly, Front (S/M type frame).....	8-1
8.2	Bed Rail Assembly, Rear (S/M type frame).....	8-2
8.3	Bed Rail Assembly, Front Middle (S/M type frame).....	8-3
8.4	Bed Rail Assembly, Rear Middle (S/M type frame).....	8-4
8.5	Bed Rail Assembly (L type frame).....	8-5
8.6	Bed Rail Assembly (L type frame).....	8-6
8.7	Stationary Leg	8-7
8.8	Pivot Bed Rail Assembly.....	8-8
8.9	Stationary Legs.....	8-10
8.10	Board Return Table, Log Side Support Assembly	8-12
8.11	Tie Down Chain Assembly	8-14
8.12	Bed Frame Decals.....	8-14
SECTION 9	LOG CLAMP, TURNER, LOADER & TOE BOARDS	9-1
9.1	Manual Log Clamp	9-1
9.2	Log Clamp Assembly	9-2
9.3	Manual Log Turner.....	9-4
9.4	Manual Toe Board.....	9-6
9.5	Manual Log Loader (S/M type frame)	9-7
9.6	Manual Log Loader (L type frame).....	9-9
9.7	Manual Log Loader Pump.....	9-11

SECTION 1 GENERAL INFORMATION

1.1 How To Use The Parts List

- Use the index above to locate the assembly that contains the part you need.
- Go to the appropriate section and locate the part in the illustration.
- Use the number pointing to the part to locate the correct part number and description in the table.
- Parts shown indented under another part are included with that part.
- Parts marked with a diamond (◆) are only available in the assembly listed above the part.

See the sample table below. Sample Part #A01111 includes part F02222-2 and subassembly A03333. Subassembly A03333 includes part S04444-4 and subassembly K05555. The diamond (◆) indicates that S04444-4 is not available except in subassembly A03333. Subassembly K05555 includes parts M06666 and F07777-77. The diamond (◆) indicates M06666 is not available except in subassembly K05555.

1.2 Sample Assembly				
REF	DESCRIPTION (◆ Indicates Parts Available In Assemblies Only)	PART #	QTY.	
	Sample Assembly, Complete (Includes All Indented Parts Below)	A01111	1	
1	Sample Part	F02222-22	1	
	Sample Subassembly (Includes All Indented Parts Below)	A03333	1	
2	Sample Part (◆ Indicates Part Is Only Available With A03333)	S04444-4	1	◆
	Sample Subassembly (Includes All Indented Parts Below)	K05555	1	
3	Sample Part (◆ Indicates Part Is Only Available With K05555)	M06666	2	◆
4	Sample Part	F07777-77	1	

To Order Parts:

- From Europe call our European Headquarters and Manufacturing Facility in Kolo, Poland at **+48-63-2626000**. From the continental U.S., call our toll-free Parts hotline at **1-800-448-7881**. Have your customer number, vehicle identification number, and part numbers ready when you call.
- From other international locations, contact the Wood-Mizer distributor in your area for parts.

SECTION 2 BLADE GUIDE ROLLERS & ARM

2.1 Blade Guide Assembly, Idle Side

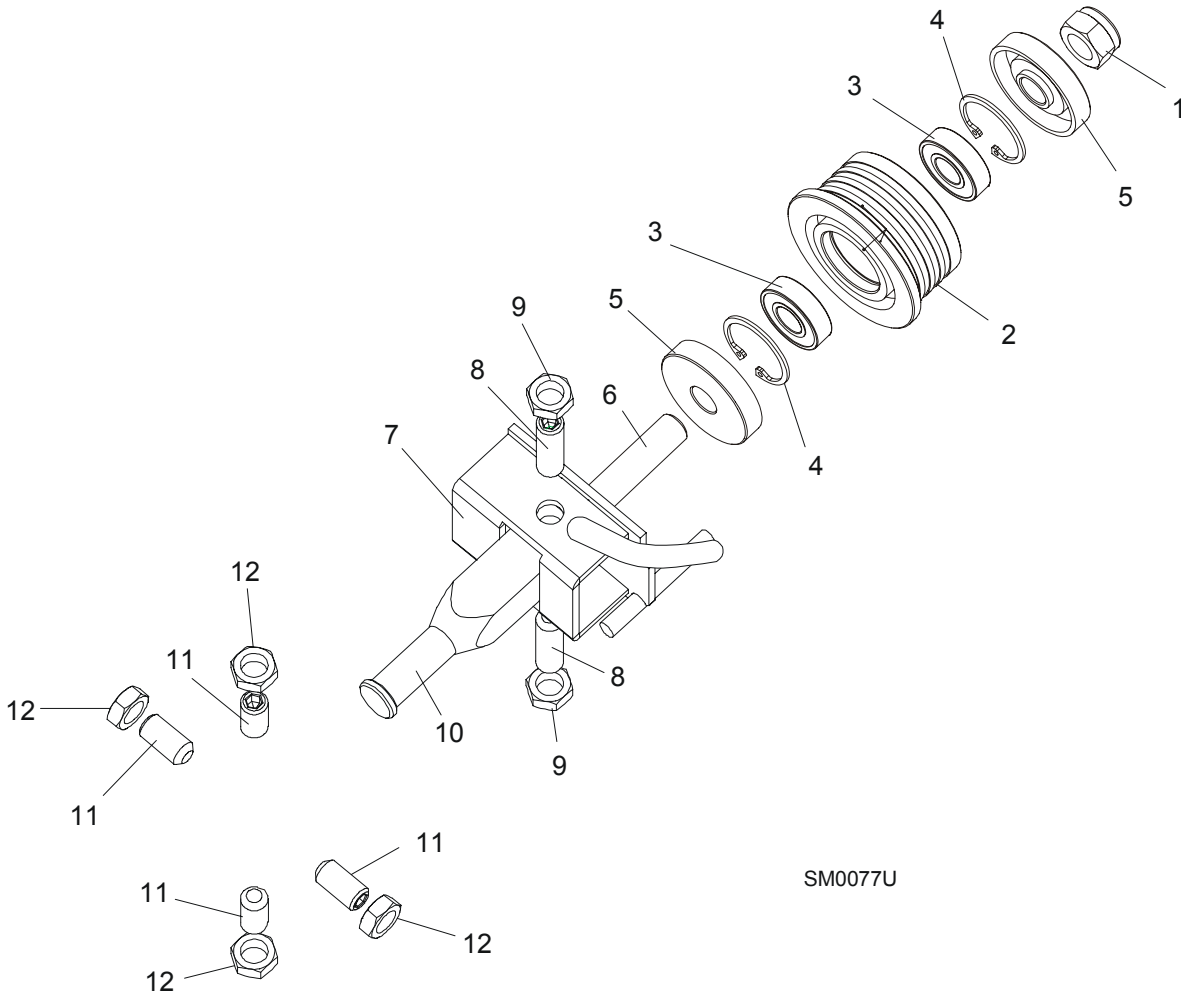

SM0077U

REF	DESCRIPTION (◆ Indicates Parts Available In Assemblies Only)	PART #	QTY.	
	BLADE GUIDE ASSEMBLY, IDLE SIDE	094683	1	
	Roller, Blade Guide Complete Standard	087887	1	
1	Nut, M12-8 Hex Nylon Zinc Lock	F81034-2	1	
2	Roller, Blade Guide Narrow	087889	1	◆
3	Bearing, 6001 2RSR FAG	087893	2	
4	Ring, W28 Inside Retaining	F81090-9	1	
5	Washer, Zinc-plated Spacer	087891-1	2	
6	Shaft, Blade Guide Roller Zinc-plated	087763-1	1	
7	Bracket Weldment, Idle Side Blade Guide Painted	094681-1	1	
8	Screw, M10x1x40 DIN 913 A2-70 Set Stainless Steel	F81015-2	2	
9	Nut, M10x1-04-ST-A2 ISO 8675 Thin	F81033-10	2	
10	Shaft, Blade Guide Mount Zinc-plated	088255-1	1	
11	SCREW, M10X1X20 DIN 913 SET STAINLESS STEEL	F81015-1	4	
12	NUT, M10x1-04-ST-A2 ISO 8675 THIN	F81033-10	4	

2.2 Blade Guide Assembly, Drive Side

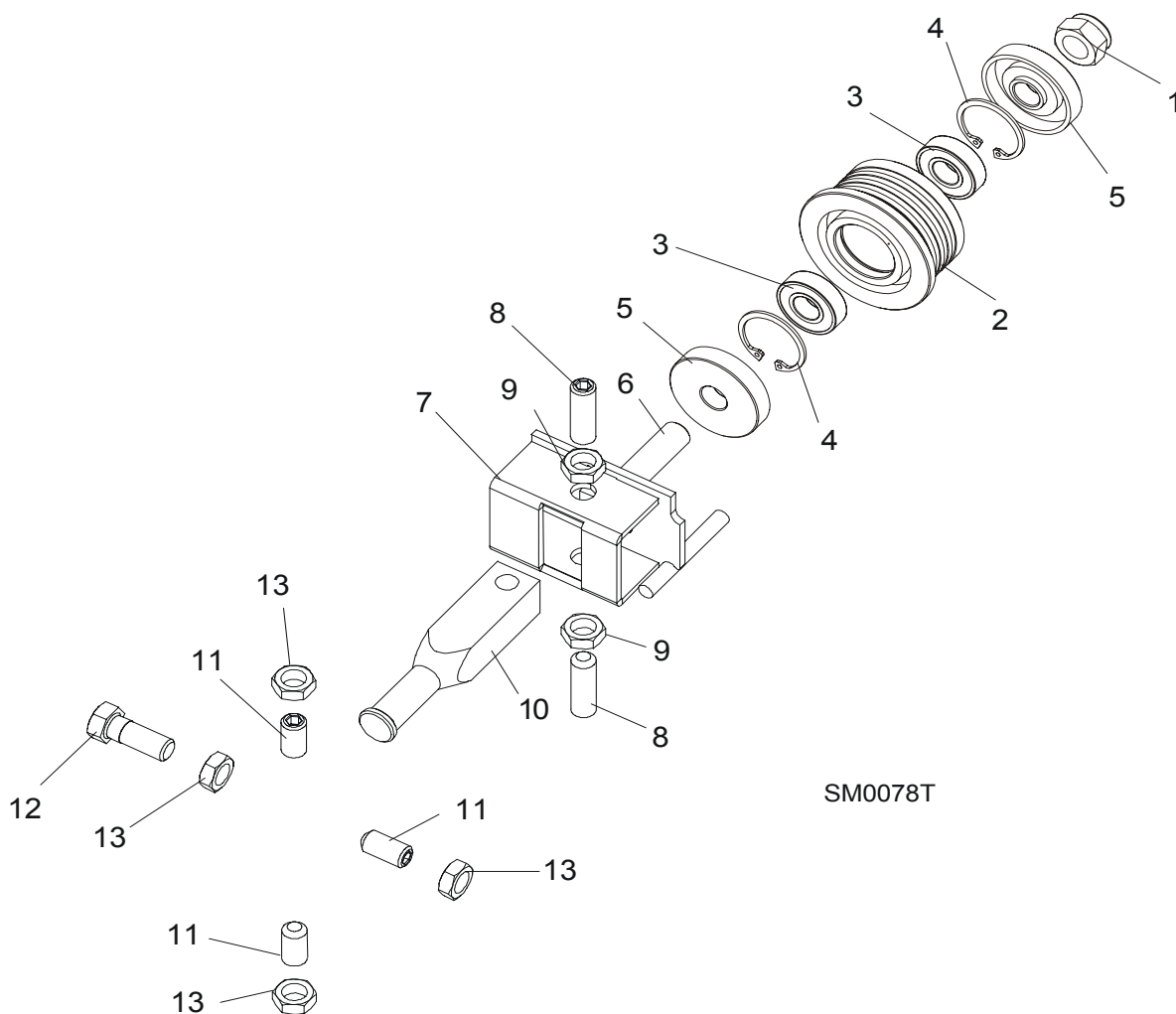

REF	DESCRIPTION (◆ Indicates Parts Available In Assemblies Only)	PART #	QTY.	
	BLADE GUIDE ASSEMBLY, DRIVE SIDE	094682	1	
	Roller, Blade Guide Complete Standard	087887	1	
1	Nut, M12-8 Hex Nylon Zinc Lock	F81034-2	1	
2	Roller, Blade Guide Narrow	087889	1	◆
3	Bearing, 6001 2RSR FAG	087893	2	
4	Ring, W28 Inside Retaining	F81090-9	1	
5	Washer, Zinc-plated Spacer	087891-1	2	
6	Shaft, Blade Guide Roller Zinc-plated	087763-1	1	
7	Bracket Weldment, Blade Guide Painted	094679-1	1	
	Screw Kit, Blade Guide Adjustment w/Nuts (for two blade guide assemblies)	K09942	1	
8	Screw, M10x1x40 DIN 913 A2-70 Set Stainless Steel	F81015-2	2	
9	Nut, M10x1-04-ST-A2 ISO 8675 Thin	F81033-10	2	
10	Shaft, Blade Guide Mount Zinc-plated	088255-1	1	
11	SCREW, M10X1X20 DIN 913 SET STAINLESS STEEL	F81015-1	3	
12	BOLT, M10X1X25 DIN 933 STAINLESS STEEL	F81003-28	1	

13	NUT, M10x1-04-ST-A2 ISO 8675 THIN	F81033-10	4	
----	-----------------------------------	-----------	---	--

2.3 Blade Guide Arm & Rollers

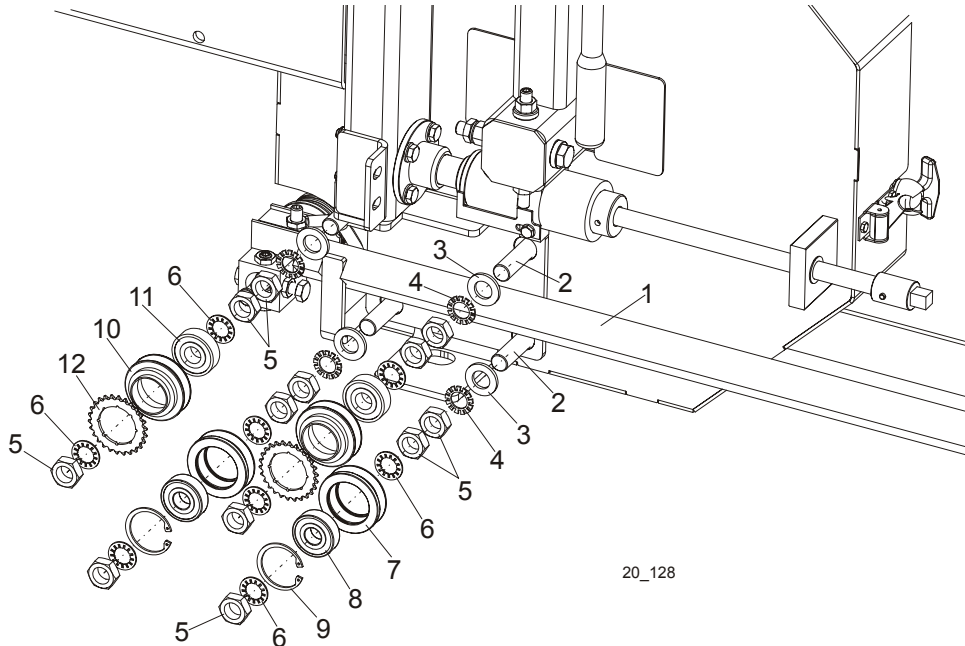

20_128

REF	DESCRIPTION (◆ Indicates Parts Available In Assemblies Only)	PART #	QTY.	
1	BLADE GUIDE ARM WELDMENT	096397-1	1	
2	BOLT, BLADE GUIDE ARM ROLLER CAM	086508-1	4	
3	WASHER, M16,FLAT ZINC	F81058-1	4	
4	WASHER, 5/8" EXTERNAL STAR	F05011-26	4	
5	NUT, 5/8-18 HEX JAM	F05010-11	12	
6	WASHER, 5/8" INTERNAL STAR	F05011-25	8	
	ROLLER ASSY, BLADE GUIDE ARM WITH BEARING	093855	2	
7	Roller, Blade Guide Arm V-Groove	093856-1	1	◆
8	Bearing, 6203 2RSP6-5/8 CX	095087	1	
9	Ring, W40 Retaining	F81090-3	1	
	ROLLER ASSY, BLADE GUIDE ARM DRIVE	A09932	2	
10	Roller, Blade Guide Arm Drive	S09930	1	◆
11	Bearing, 6203-2 RSP6-5/8 CX	095087	1	
12	Sprocket	S09931	1	◆

2.4 Blade Guide Arm Drive Assembly

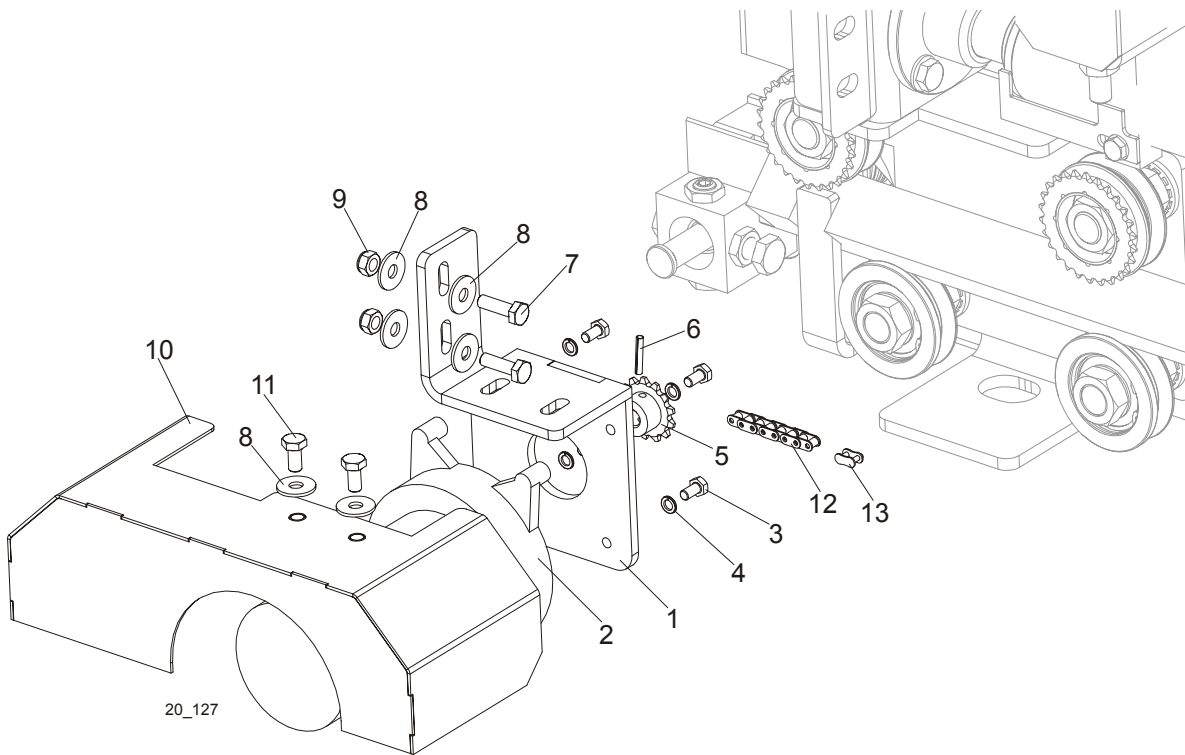

REF	DESCRIPTION (◆ Indicates Parts Available In Assemblies Only)	PART #	QTY.
	DRIVE ASSEMBLY, BLADE GUIDE ARM	096396	1
1	Bracket, Blade Guide Arm Motor Mount	096390-1	1
2	Motor, Blade Guide Arm 53:1 Gear	P09698-1	1
3	Screw, 10-32x1/2 HH Machine	F05004-60	4
4	Washer, 5.1 Split Lock	F81052-2	4
5	Sprocket, 25B13x.3130	P09970	1
6	Pin, 1/8x3/4 Roll	F05012-6	1
7	Bolt, M6x20mm, HH, Full Thread, Zinc	F81001-2	2
8	Washer, 6.5 Flat Zinc	F81053-11	6
9	Nut, M6, Hex, Nylon Lock Zinc	F81031-2	2
10	COVER, LT20 BLADE GUIDE ARM MOTOR	097424-1	1
11	BOLT, M6X12MM HEX HEAD ZINC	F81001-7	2
12	CHAIN, 20 1/4IN #25	P09984	1
13	LINK, 25 MASTER	P09983	1

SECTION 3 BLADE WHEELS & TENSIONER

3.1 Blade Wheel Assembly, Drive Side

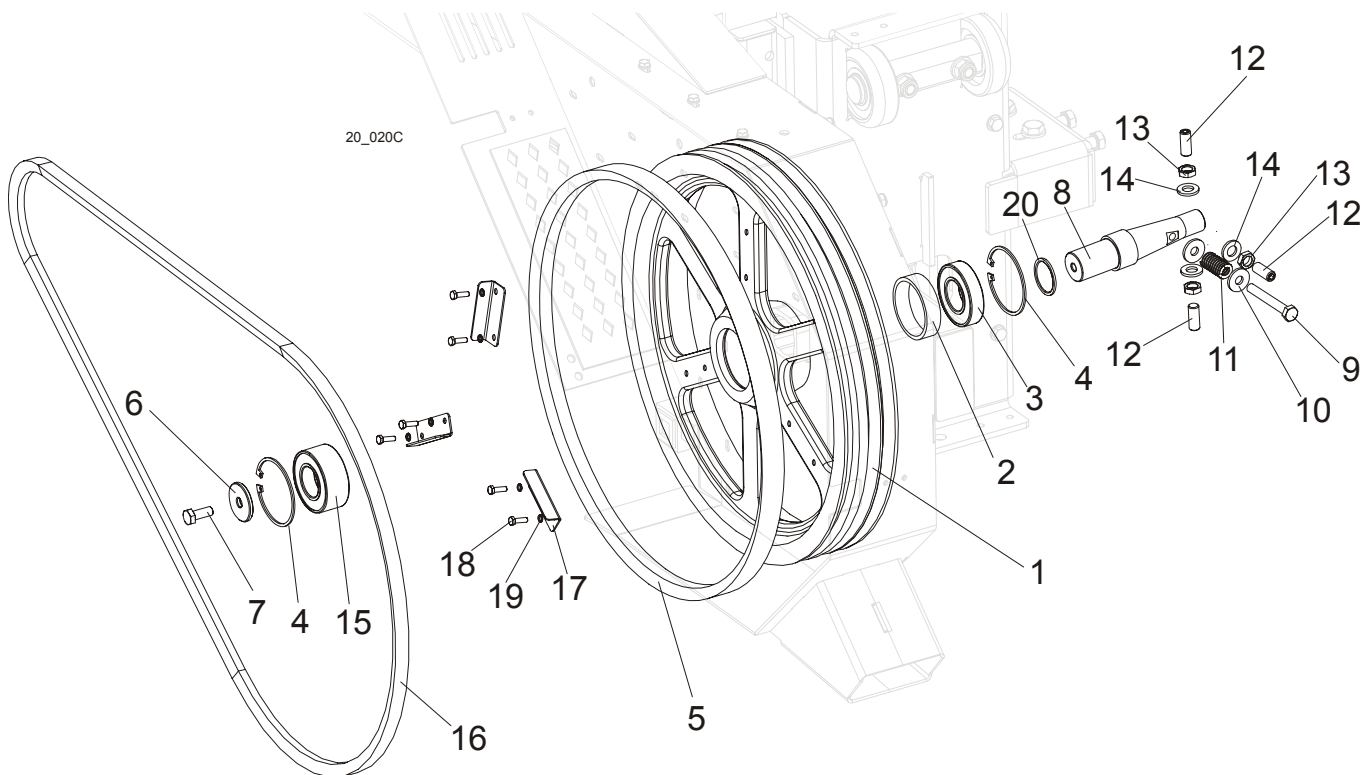

REF	DESCRIPTION (◆ Indicates Parts Available In Assemblies Only)	PART #	QTY.
	BLADE WHEEL ASSEMBLY, LT20 DRIVE SIDE	091612	1
1	Wheel, LT20 Drive Side Blade	090646-1	1
2	Bushing, Bearing Spacer	096778	1
3	Bearing, 6207 2RS 35x72x17 FAG	014811	1
4	Ring, W72 Retaining	F81090-4	2
5	Belt, B57 Blade Wheel	P04185	1
6	Washer, Drive Side Blade Wheel	092006	1
7	Bolt, M10x25-8.8 Hex Head Full Thread Zinc	F81003-11	1
8	Shaft, LT15/20 Drive Side Blade Wheel	093850	1
9	Bolt, M10X65-8.8-B Hex Head Zinc	F81003-67	1
10	Washer, Zinc	098813-1	2
11	Spring, 19x38 Compression	034430	1
12	Screw, M12x1,25x30 DIN913 Set	F81016-1	4
13	Washer, 13 Flat Zinc	F81056-1	4
14	Nut, M12x1,25 DIN439 Thin Stainless Steel	F81034-9	4
15	Bearing, 3207B, 2RSR. TVH FAQ	092005	1
16	Drive Belt, 2BX81, AC Sawmills (E11, E15) Drive Belt, 2BX84, DC Sawmills (D17, D22 & G25)	014819-2 (AC) 088110 (DC)	1 2
17	Wing	097808-1	3
18	Bolt, M6x20mm, HH, Full Thread, Zinc	F81001-2	6
19	Washer, M6 Split Lock Zinc	F81053-3	6
20	Washer, φ35 Special	091851	1

3.2 Blade Wheel Assembly, Idle Side

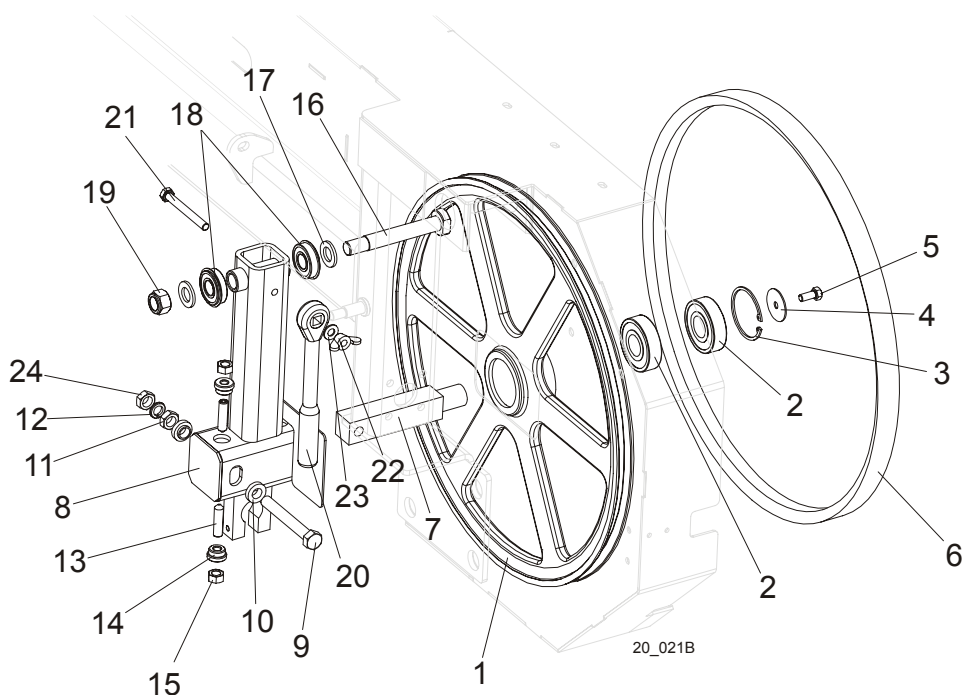

REF	DESCRIPTION (◆ Indicates Parts Available In Assemblies Only)	PART #	QTY.
	WHEEL ASSEMBLY, IDLE SIDE BLADE	A08218	1
1	Sheave, 18.62" Idler	P08125	1
2	Bearing, 6305 2RS NSK	P08066	2
3	Ring, 2 7/16" Inside Retaining	F04254-21	1
4	WASHER, WHEEL RETAINING ZINC-PLATED	093854-1	1
5	BOLT, M8 x 25mm HEX HEAD GR 5.8 ZINC	F81002-5	1
6	BELT, B57 BLADE WHEEL	P04185	1
7	SHAFT, IDLE SIDE WHEEL METRIC	096045	1
8	HOUSING, IDLER SHAFT	091595	1
9	BOLT, M12X1.25X100-8.8 HEX HEAD FULL THREAD ZINC	F81004-41	1
10	SPACER, FLANGED ZINC-PLATED	086769-1	2
11	NUT, M12 X 1.25-8 HEX ZINC	F81034-8	1
12	WASHER, 12.2 SPLIT ZINC LOCK	F81056-2	1
13	SCREW, M10 X 40-45H HEX SOCKET SET CONE POINT ZINC	F81003-61	2
14	BUSHING, M10 IDLER SHAFT HOUSING	086987	2
15	NUT, M10-8-B HEX ZINC	F81033-3	2
16	PIN, IDLER ARM BEARINGS	086404	1
17	WASHER, 17 FLAT ZINC	F81058-1	2
18	BEARING, 6203-2RS NR NSK W/RING	086395	2
19	NUT, M16-8 HEX NYLON ZINC LOCK	F81036-2	1
20	WRENCH, LT20 BLADE TENSION	091620	1
21	BOLT, M10x90-8.8-B HEX HEAD ZINC	F81003-66	1
22	STUD, M10x25-8.8 ZINC-PLATED	F81003-8	1
23	WASHER, M10 FLAT ZINC	F81055-1	1
24	NUT, M12x1.25 DIN439 THIN STAINLES STEEL	F81034-9	1

3.3 Blade Tensioner Assembly

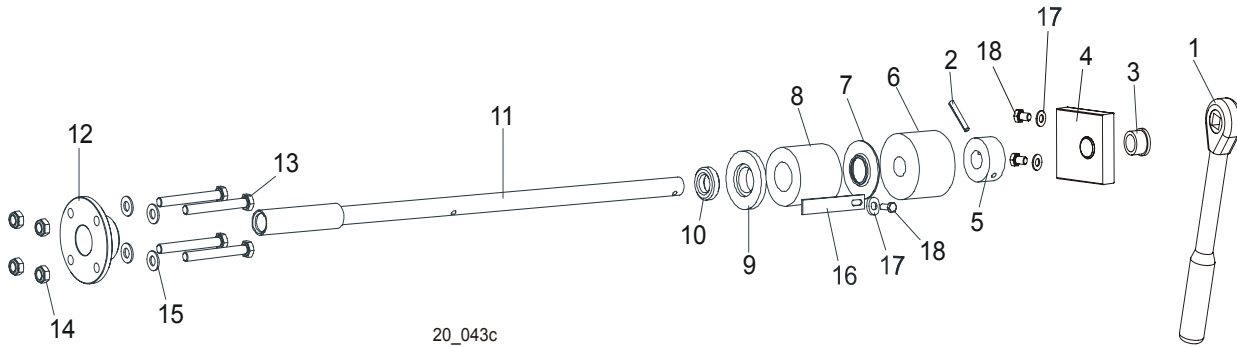

20_043c

REF	DESCRIPTION (◆ Indicates Parts Available In Assemblies Only)	PART#	QTY.
	BLADE TENSIONER ASSEMBLY	090587	1
1	Wrench, LT20 Blade Tension	091620	1
2	Pin, 5 x 30 Zinc Roll	F81044-21	1
	Bracket, Tension Handle Mount w/Bushing	096729	1
3	Bushing GFM-1618-17(IGUS)	089589	1
4	Bracket, Painted	096730	1
5	Collar, Blade Tensioner	086712-1	1
6	Bushing, Rubber Stop	P12165	1
7	Guide, LT15 Tension Handle	014925	1
8	Spring, LT15 Rubber Blade Tensioner	014828	1
9	Washer, Rubber Spring Front	086674-1	1
10	Bearing, 51103 FLT Ball Thrust	086675	1
11	Shaft Weldment, Blade Tensioner Zinc-plated	101338-1	1
12	Nut, Blade Tensioner	086672-1	1
13	Bolt, M8x70 8.8 Hex Head Zinc	F81002-71	4
14	Nut, M8-8-B Hex Nylon Zinc Lock	F81032-2	4
15	Washer, 8.4 Zinc Flat	F81054-1	8
16	Indicator, LT15 Blade Tension Zinc-plated	092467-1	1
17	Washer, 6.4 Zinc Flat	F81053-1	1
18	Bolt, M6x16 8.8 Hex Head Full Thread Zinc	F81001-15	1

SECTION 4 SAW HEAD

4.1 Middle Throat Screw

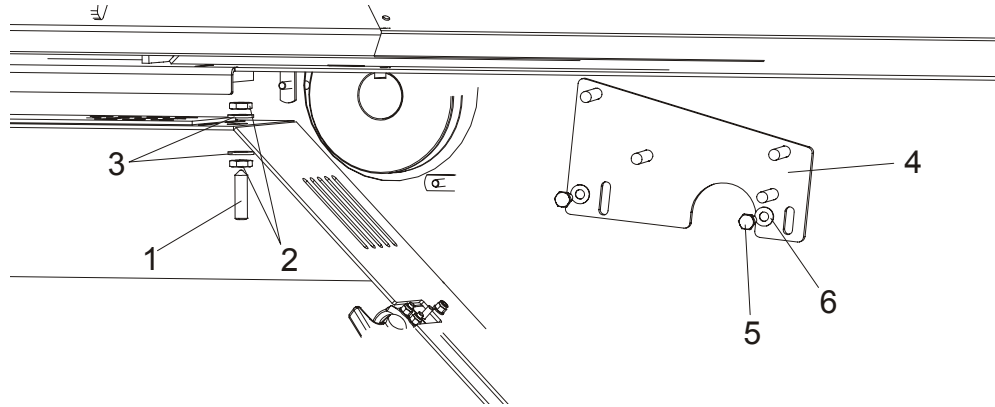

REF	DESCRIPTION (◆ Indicates Parts Available In Assemblies Only)	PART #	QTY.
1	SCREW, M10 X 40-45H HEX SOCKET SET CONE POINT ZINC	F81003-61	1
2	NUT, M10-8-B ZINC HEX	F81033-6	2
3	WASHER, 10.5 ZINC FLAT	F81055-1	2
4	BRACKET, DRIVE BELT SUPPORT, UPPER	092668-1	1
5	BOLT, M8X20-5.8 HEX HEAD FULL THREAD ZINC	F81002-1	2
6	WASHER, 8.4 ZINC FLAT	F81054-1	2

4.2 Drive Belt Tensioner, DC Sawmills

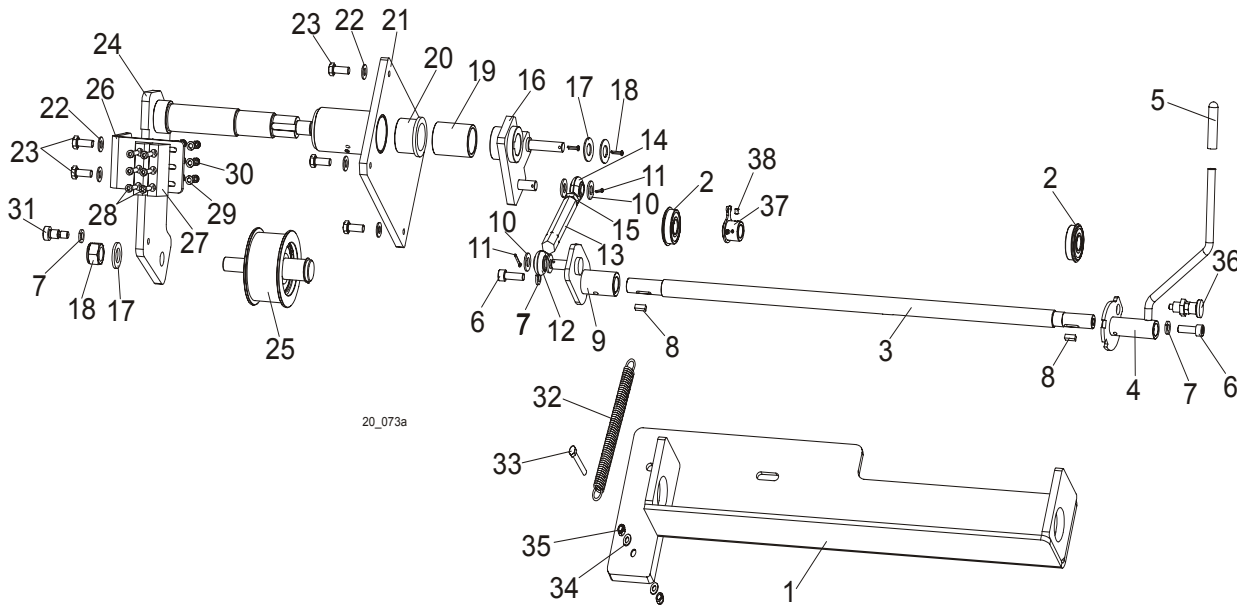

REF	DESCRIPTION (◆ Indicates Parts Available In Assemblies Only)	PART #	QTY.
	BELT TENSIONER, LT20 COMPLETE, D22	098456	1
	BELT TENSIONER, LT20 COMPLETE, G25	097842	1

1	Mount Weldment, Belt Tensioner Ptd	091169-1	1	
2	Bearing, 6203-2RS NR NSK w/Ring	086395	2	
3	Rod, LT20 Belt Tensioner Ptd	091176-1	1	
4	Handle Weldment, Accelerate/Brake, Ptd	097837-1	1	
5	Grip, Handle 1/2" ID x 3" Long	014835	1	
6	Screw, M8x25 -8.8 Hex Socket Head Cap Zinc	F81002-21	2	
7	Washer, 8.2 Split Lock Zinc	F81054-4	3	
8	Key, B 5x5.1x14 Parallel	087365	2	
9	Bracket, Belt Tensioner Pivot	091245-1	1	
10	Washer, 10.5 Zinc Flat	F81055-1	4	
11	Pin, 2.5x20 Zinc Cotter	F81043-1	2	
12	Rod End, 7/16-20 Right-Hand Male	P11579	1	
13	Turnbuckle, Clutch/Brake	S11577	1	
14	Rod End, 7/16-20 Left-Hand Male	P11578	1	
15	Nut, 7/16-20 Zinc	F05010-38	1	
16	Arm Weldment, Belt Tensioner Ptd	091172-1	1	
17	Washer, 17 Zinc Flat	F81058-1	2	
18	Nut, M16-8 Hex Nylon Zinc Lock	F81036-2	2	
19	Bushing, Spacer Ptd	091351-1	1	
20	Bushing, MFM-3240-30 (IGUS)	088461	2	
21	Mount Weldment, Tensioner Shaft Ptd	091112-1	1	
22	Washer, 8.4 Zinc Flat	F81054-1	7	
23	Bolt, M8x20-5.8 Hex Head Full Thread Zinc	F81002-1	6	
24	Shaft Weldment, Belt Tensioner Ptd	097828-1	1	
25	Roller, Belt Tension	097832	1	
26	Bracket, Brake Block Mount Ptd	091248-1	1	
27	Block, F9150 123 Belt Tensioner Brake	087648	2	
28	Screw, M5x25-8.8 Hex Socket Head Cap Zinc	F81000-7	6	
29	Washer, 5.3 Zinc Flat	F81052-1	6	
30	Nut, M5-8 Zinc DIN 985	F81030-2	6	
31	Screw, M8x25-8.8 Hex Socket Head Cap Zinc	F81002-21	2	
32	Spring, Hydraulic Log Turner	P09136	1	
33	Bolt, M8x45-8.8 Hex Head Zinc	F81002-17	1	
34	Washer, 8.4 Zinc Flat	F81054-1	2	
35	Nut, M8-8-B Hex Nylon Zinc Lock	F81032-2	2	
36	Pin, Detent	089939	1	
37	Tension Member, (G25 Engine Only) Ptd	092535-1	1	
38	Set Screw M6x8	F81013-1	2	

4.3 Water Lube Assembly

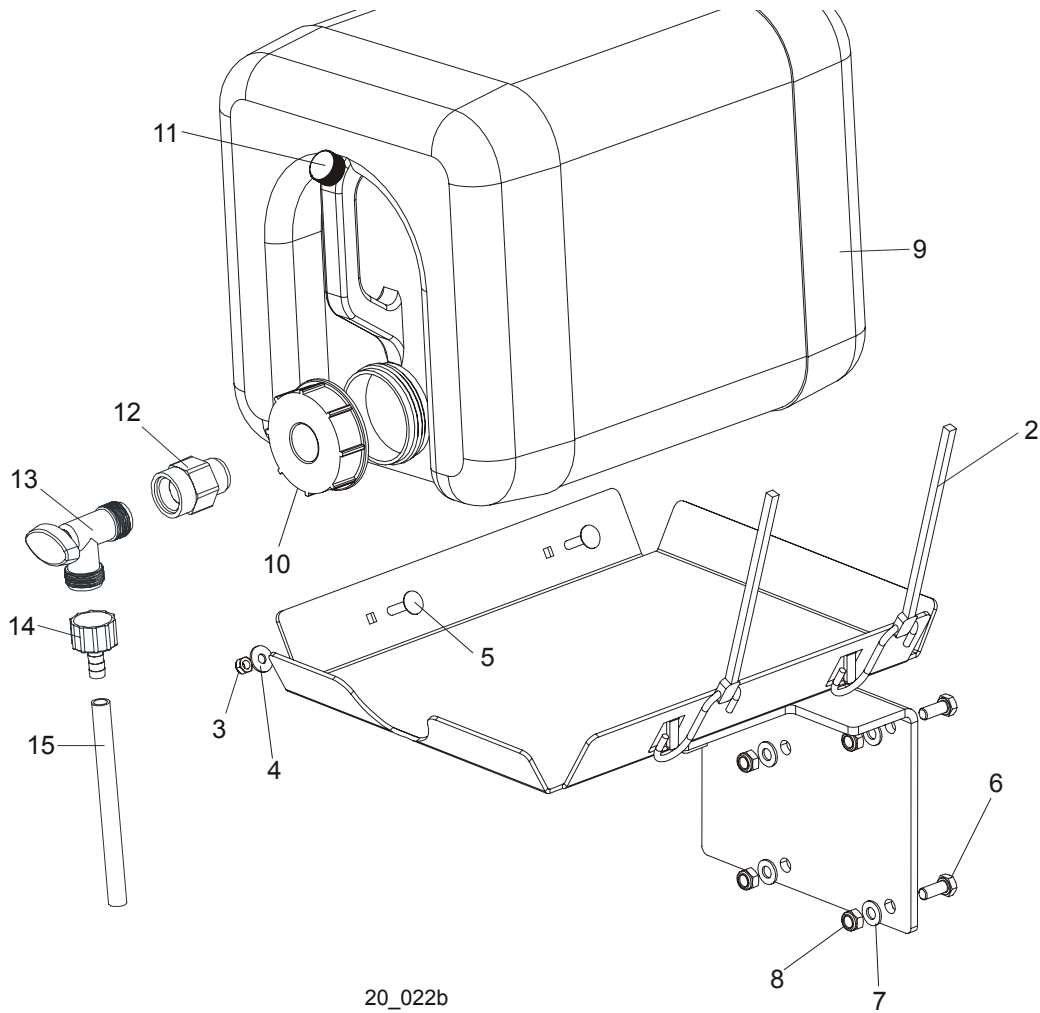

REF	DESCRIPTION (◆ Indicates Parts Available In Assemblies Only)	PART #	QTY.
	BOTTLE KIT, LT20 WATER LUBE	091036	1
1	Tray Weldment, LT20 Water Lube	091033-1	1
2	Strap, 20" Rubber	P11668	2
3	Nut, M6-8-B Hex Nylon Zinc Lock	F81031-2	2
4	Washer, 6.5 Zinc Flat	F81053-11	2
5	Bolt, M6x25-8.8 Carriage Head Zinc	F81001-20	2
6	Bolt, M8x20-8.8 Hex Head Full Thread Zinc	F81002-1	2
7	Washer, 8.4 Zinc Flat	F81054-1	2
8	Nut, M8-8-B Hex Nylon Zinc Lock	F81032-2	2
	Bottle, 5-gallon Water Complete	014637-1	1
9	Bottle, 5-gallon Water	101295	1
10	Cap, 5-gallon Water Bottle	036745	1
11	Cap, Vent Valve	061742	1
12	Fitting, 3/4FPT x 3/4MPT	014636	1
13	Fitting, Water Lube Shutoff Valve	014100	1
14	Fitting, 5/8" NPT to 3/8" Hose Barb	014113	1
15	Tubing, Water Lube	R01885	2.1 m

4.4 LT20AC Saw Head Decals

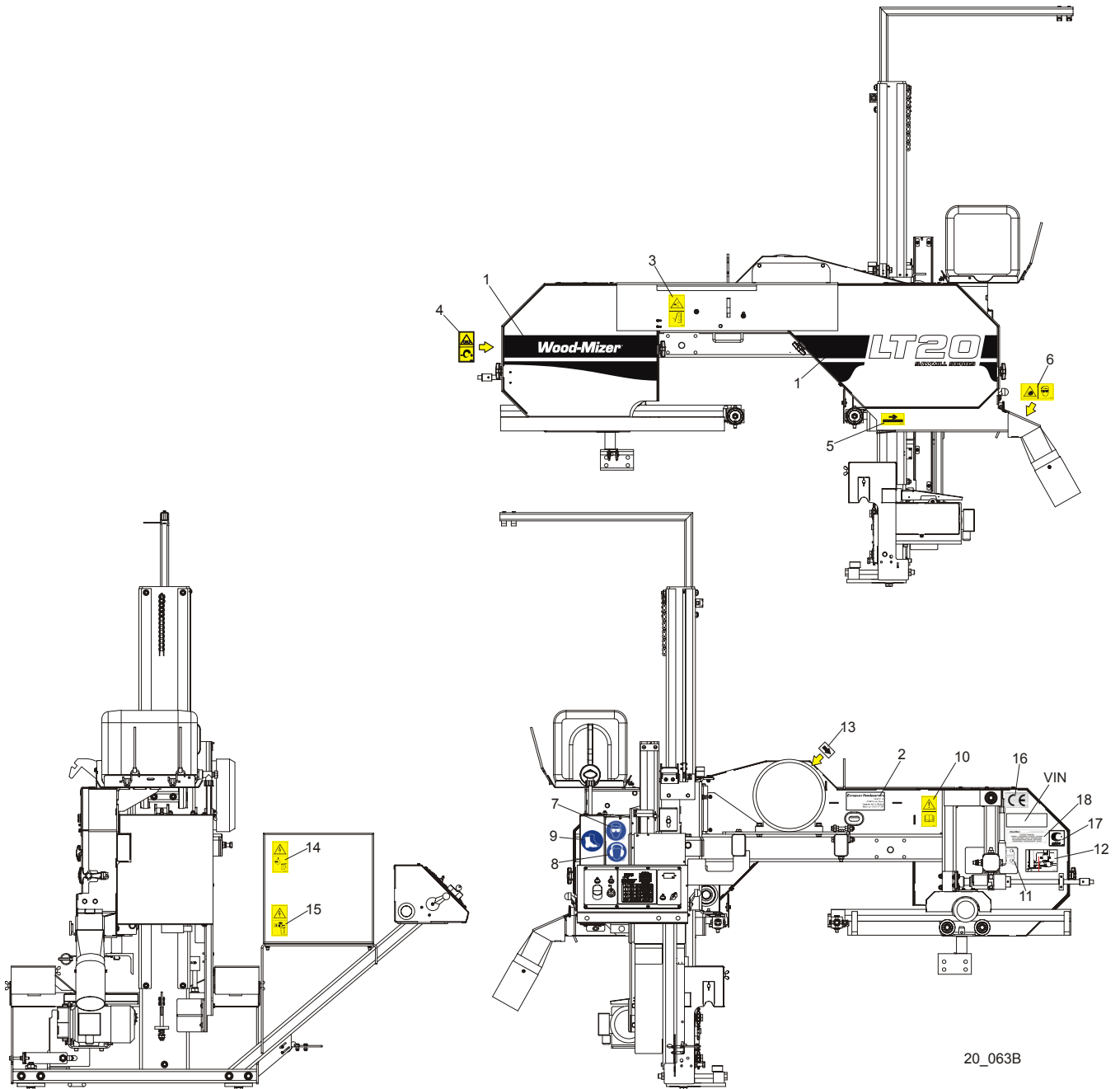

20_063B

REF	DESCRIPTION (◆ Indicates Parts Available In Assemblies Only)	PART #	QTY.
1	DECAL, LT20 SERIES SAWMILL	092762	1
	PICTOGRAPHIC DECAL KIT, LT20AC	099509	1
2	DECAL, EUROPEAN HEADQUARTERS ADDRESS	015841	1
3	DECAL, SAWMILL COVERS CAUTION	099220	1
4	DECAL, BLADE TENSION (PICTOGRAM)	099219	1
5	DECAL, BLADE MOVEMENT DIRECTION (PICTOGRAM)	096321	1
6	DECAL, SAWDUST CHUTE WARNING (PICTOGRAM)	099222	1
7	DECAL, EYE PROTECTION WARNING (PICTOGRAM)	S12004G	1

8	DECAL, EAR PROTECTION WARNING (PICTOGRAM)	S12005G	1	
9	DECAL, USE SAFETY BOOTS (PICTOGRAM)	501465	1	
10	DECAL, READ OPERATOR'S MANUAL (PICTOGRAM)	096317	1	
11	DECAL, BLADE ALIGNMENT	P11789	1	
12	DECAL, BLADE TENSION INDICATOR ADJUSTMENT	092597	1	
13	DECAL, MOTOR ROTATION DIRECTION	S20097	1	
14	DECAL, HIGH VOLTAGE INSIDE THE ELECTRIC BOX (PICTOGRAM)	096316	1	
15	DECAL, REMOVE THE PLUG BEFORE OPENING THE BOX (PICTOGRAM)	096319	1	
16	DECAL, CE CERTIFIED SAWMILL	P85070	1	
17	DECAL, RUSSIAN SAFETY CERTIFICATION	099401	1	
18	DECAL, INTERNATIONAL SAWMILL NAME	501466	1	

4.5 LT20DC Saw Head Decals

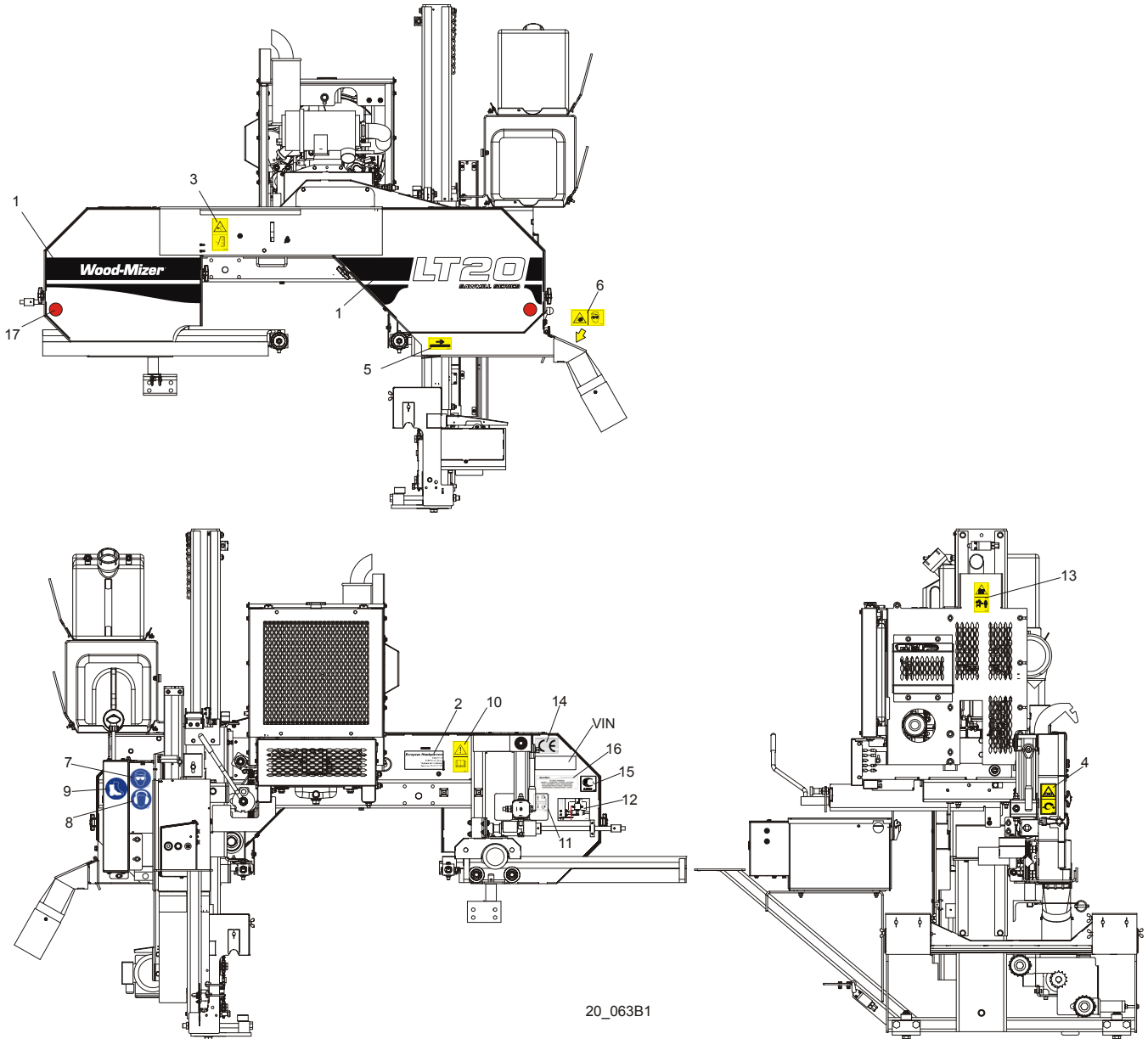

20_063B1

REF	DESCRIPTION (◆ Indicates Parts Available In Assemblies Only)	PART #	QTY.
	PICTOGRAPHIC DECAL KIT, LT20DC	099510	1
1	DECAL, LT20 SERIES SAWMILL	092762	1
2	DECAL, EUROPEAN HEADQUARTERS ADDRESS	015841	1
3	DECAL, SAWMILL COVERS CAUTION	099220	1
4	DECAL, BLADE TENSION (PICTOGRAM)	099219	1
5	DECAL, BLADE MOVEMENT DIRECTION (PICTOGRAM)	096321	1
6	DECAL, SAWDUST CHUTE WARNING (PICTOGRAM)	099222	1
7	DECAL, EYE PROTECTION WARNING (PICTOGRAM)	S12004G	1
8	DECAL, EAR PROTECTION WARNING (PICTOGRAM)	S12005G	1
9	DECAL, USE SAFETY BOOTS (PICTOGRAM)	501465	1

4

Saw Head*LT20DC Saw Head Decals*

10	DECAL, READ OPERATOR'S MANUAL (PICTOGRAM)	096317	1	
11	DECAL, BLADE ALIGNMENT	P11789	1	
12	DECAL, BLADE TENSION INDICATOR ADJUSTMENT	092597	1	
13	DECAL, KEEP AWAY - HOT PARTS (PICTOGRAM)	086099	1	
14	DECAL, CE CERTIFIED SAWMILL	P85070	1	
15	DECAL, RUSSIAN SAFETY CERTIFICATION	099401	1	
16	DECAL, INTERNATIONAL SAWMILL NAME	501466	1	
17	REFLECTOR, 2 DIA RED (MOBILE SAWMILLS ONLY)	P07452	1	

4.6 Blade Housing Cover

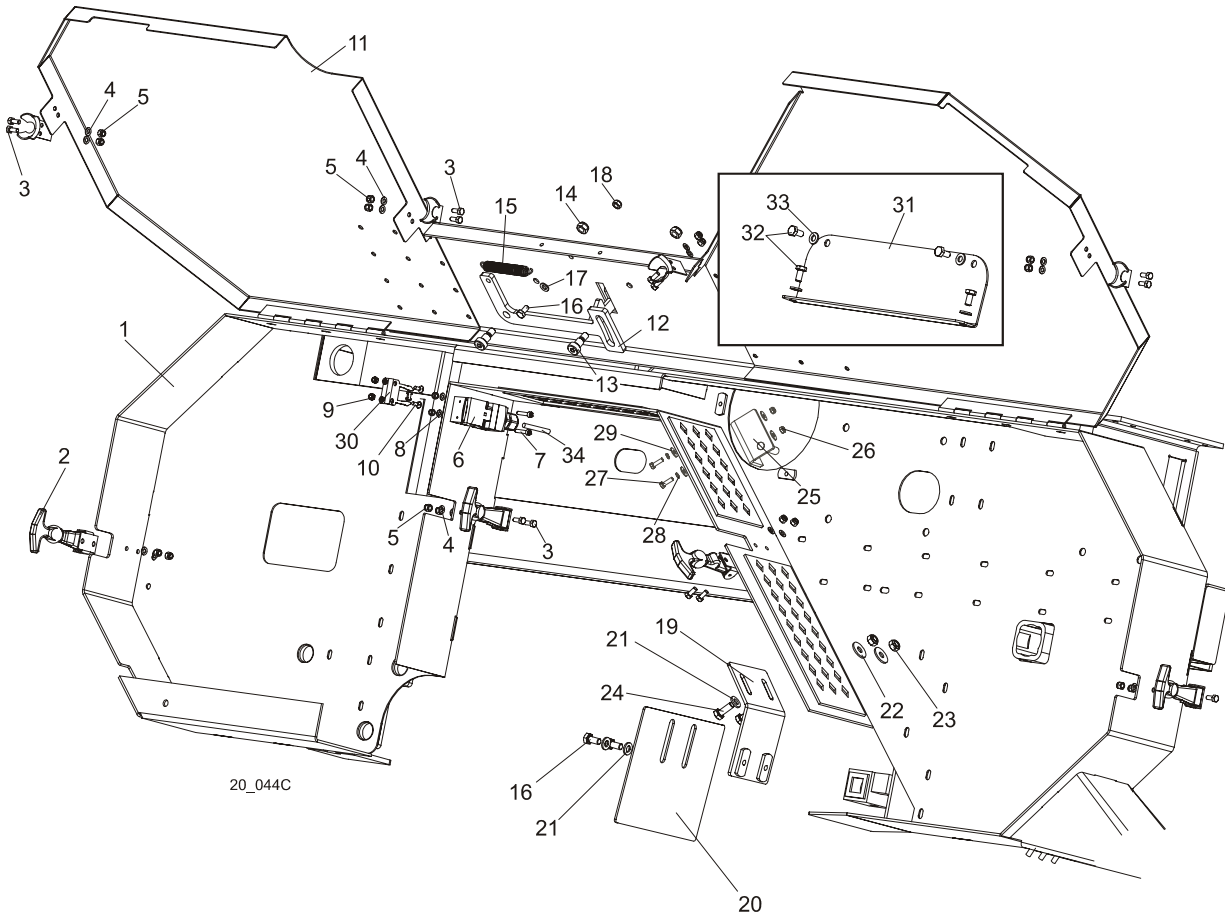

REF	DESCRIPTION (◆ Indicates Parts Available In Assemblies Only)	PART #	QTY.
1	SAW HEAD WELDMENT, LT20	090567	1
2	LATCH, FLEXIBLE DRAW	014829	4
3	BOLT, M5 X 12-5.8 HEX HEAD FULL THREAD ZINC	F81000-5	16
4	WASHER, 5.3 ZINC FLAT	F81052-1	16
5	NUT, M5-8 HEX NYLON ZINC LOCK	F81030-2	16
6	SWITCH, AZ17-11ZRK SAFETY KEY	094232	1
7	SCREW, M4 X 35 8.8 HEX SOCKET HEAD CAP ZINC	F81011-34	2
8	WASHER, 4.3 ZINC FLAT	F81051-2	4
9	NUT, M4-B HEX NYLON ZINC LOCK	F81029-1	4
10	SCREW, M4 X 12 5.8-B SLOTTED COUNTERSUNK HEAD ZINC	F81011-43	2
11	COVER WELDMENT, LT20 BLADE HOUSING PTD	096776-1	1
12	PAWL, LOCKING PTD	090643-1	1
13	SCREW, 10/M8 X 12-12.9 ISO-7379 SOCKET HEAD SHOULDER	F81003-62	2
14	NUT, M8-8-B HEX NYLON ZINC LOCK	F81032-2	2
15	SPRING, 1,6x12x38 EXTENSION	092208	1
16	BOLT, M6 X 12-8.8 HEX HEAD FULL THREAD ZINC	F81001-7	3
17	WASHER, 6.4 ZINC FLAT	F81053-1	1

18	NUT, M6-8-B HEX NYLON ZINC LOCK	F81031-2	1	
19	BRACKET, BLADE GUIDE ROLLER GUARD PAINTED	092378-1	1	
20	GUARD, BLADE GUIDE ROLLER PAINTED	092379-1	1	
21	WASHER, 6.4 ZINC FLAT	F81053-1	4	
22	WASHER, 6.5 ZINC FLAT	F81053-11	2	
23	NUT, M6-8-B HEX NYLON ZINC LOCK	F81031-2	2	
24	BOLT, M6X16 8.8 HEX HEAD FULL THREAD ZINC	F81001-15	2	
25	BRACKET WLDMT, PTD DRIVE BELT SUPPORT	092636-1	1	
26	NUT, M6-8-B HEX NYLON ZINC LOCK	F81031-2	2	
27	BOLT, M6 X 20-8.8 HEX HEAD FULL THREAD ZINC	F81001-2	2	
28	WASHER 6,1 FE/ZN9 PN/M-82008	F81053-3	2	
29	WASHER, 6.5 ZINC FLAT	F81053-11	4	
30	KEY, AZ17/170-B5 SAFETY SWITCH	094422	1	
31	COVER, SAW HEAD MOUNT	096788-1	1	
32	BOLT, M6X12MM HEX HEAD ZINC	F81001-7	4	
33	WASHER, M6 FLAT ZINC	F81053-1	4	
34	CABLE, OLFLEX 400P 2X1	R80583-5	3m (DC) 5m (AC)	

4.7 Control Box (AC Sawmills)

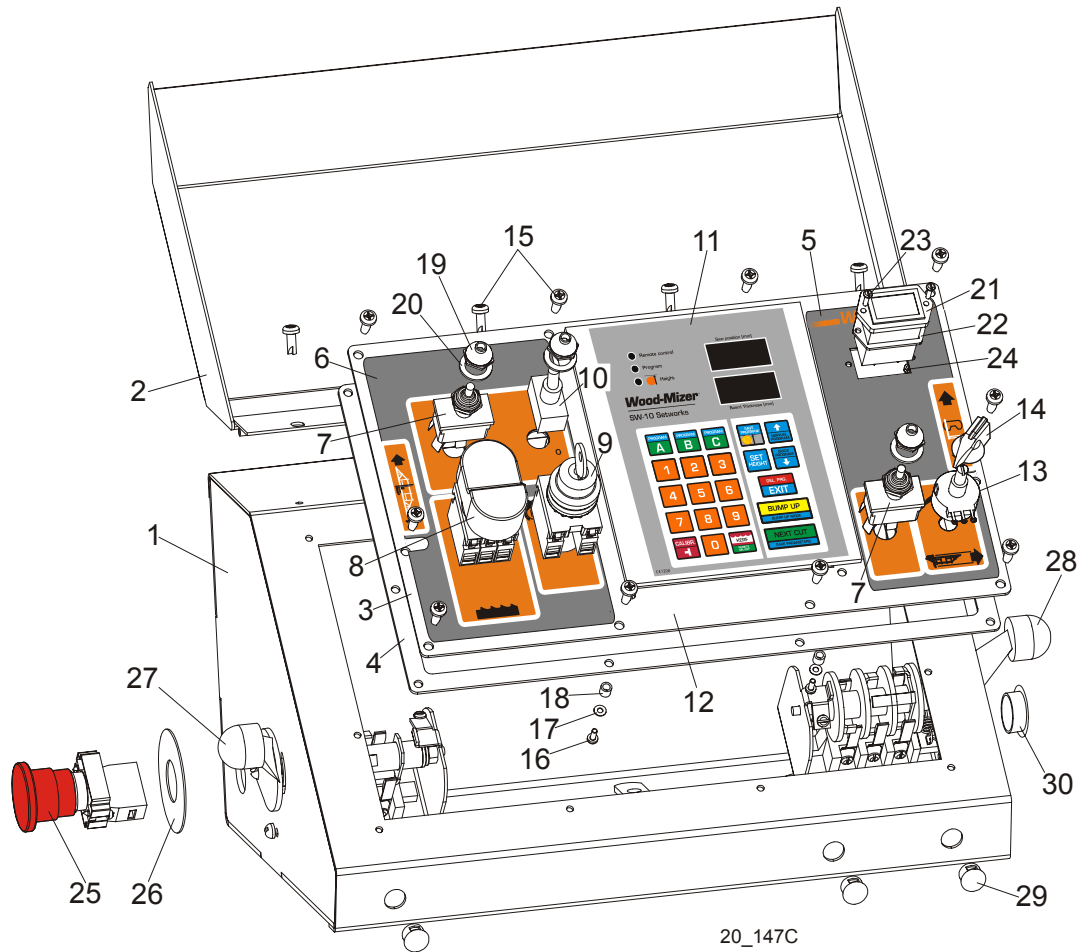

REF	DESCRIPTION (◆ Indicates Parts Available In Assemblies Only)	PART #	QTY.
	CONTROL BOX ASSEMBLY, LT20 AC COMPLETE	097136	1
1	Box Weldment, LT20 AC Control	097134-1	1
2	Cover Control Box, LT20	097135-1	1
3	Panel, LT20AC Front Control Complete	097131	1
4	Gasket, LT20 Control Box	097132	1
5	Decal, LT20AC/DC Control Box Right	099593	1
6	Decal, LT20AC Control Box Left	099594	1
7	Switch, DPDT Toggle 21A Rev Mom Spade	024200	2
8	Button, 24V Start/Stop	090452	1
	Membrane M22-T-DD	090462	1
9	Switch, M22 3-position Key	091361	1
	Contact, M22 - K10	091362	2
10	Switch, SPST ON/OFF 15A .25 Tabs Toggle	P03027	1
11	Controller, SW-10 Setworks	500628	1
12	Panel, LT20/40AC Front Control	100572-1	1
13	Potentiometer, 1K Feed Rate	E20519	1
14	Knob, Speed Control	P06257	1
15	Bolt, #10-24x1/2 Ph Pan Hd, Type 23	F05015-17	14

16	Screw, M3x8 -4.8- Fe/Zn5 PN-M/82202	F81000-83	6	
17	Washer, 3.2 Fe/Zn5 PN-M/82005	F81050-2	6	
18	Tube, 6mm 4.2 long	R80671-4	6	
19	Boot, Toggle Switch	P02575	3	
20	Washer, 1/2x3/4x1/16 Nylon	P05251-1	3	
21	Meter, Hour	093166	1	
22	Gasket, Hour Meter	093346	1	
23	Bolt, M3x12-8.8 Zinc	F81000-12	2	
24	Nut, M3-6 Hex Nylon Zinc Lock	F81028-2	2	
25	Button, XB4 BS542 Emergency Stop	086556	1	
26	Washer, Emergency Stop Switch	086561	1	
27	Switch, 1992GS Pwr/Feed (Service Package)	E20438	1	
28	Switch, 1992 Up/Down (Service Package)	E20440	1	
29	Cap, DP 812 Heyman 12.7 Dia. Hole	086773	3	
30	Cap, SR1086 22.2 Dia. Hole	093544	1	

4.8 Control Box (DC Sawmills)

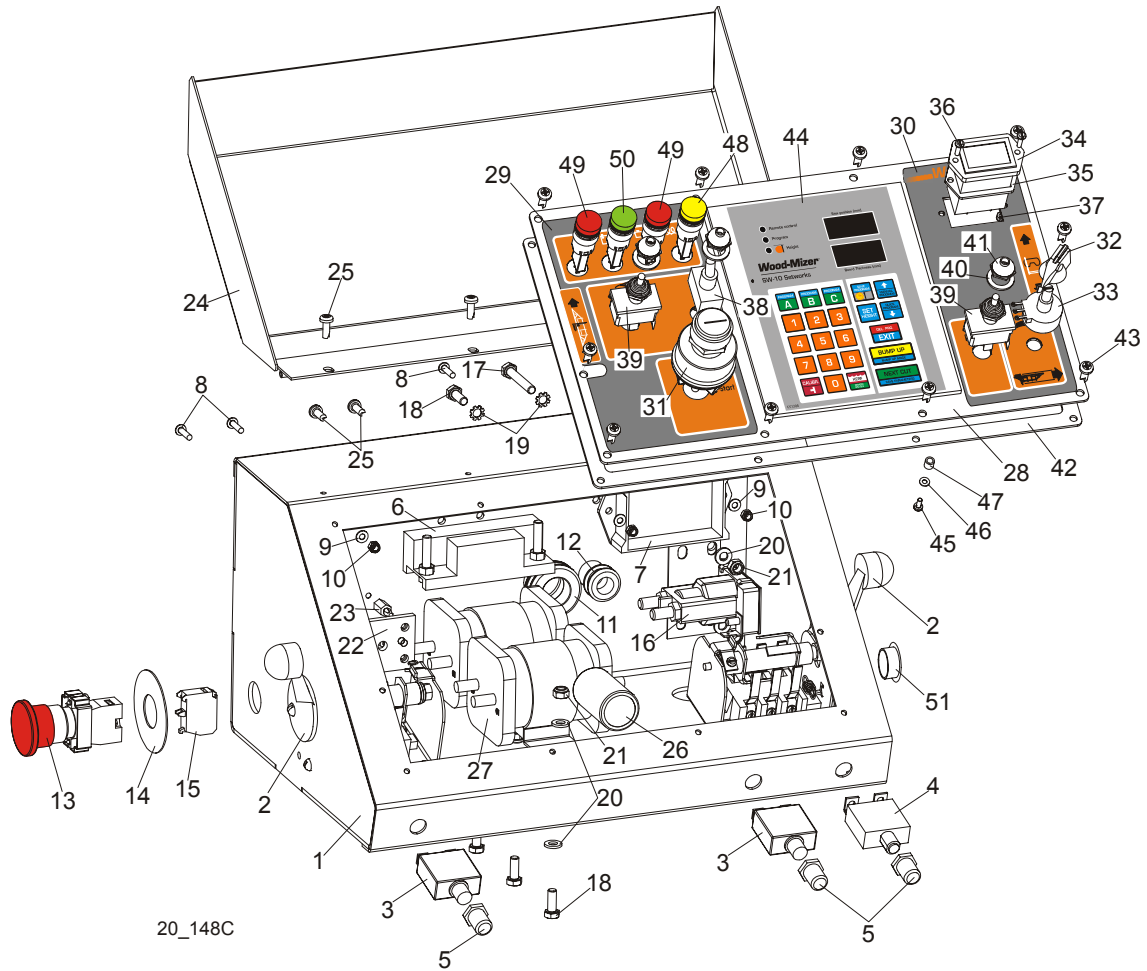

20_148C

REF	DESCRIPTION (◆ Indicates Parts Available In Assemblies Only)	PART #	QTY.
	CONTROL BOX ASSEMBLY, LT20 DC DIESEL COMPLETE	097167	1
1	Box Weldment, LT20 DC	097165-1	1
2	Switch, 1992GS Pwr/Feed (Service Package)	E20438	2
3	Breaker, 50A Manual Reset Panel Mount	021256	2
4	Breaker, 30A Manual Reset Panel Mount	024246	1
5	Boot, Circuit Breaker	021253	3
6	Module Assy, Mosfet 4x 92-96 P/F	024540	1
7	Control Module Assy, P/F SMT Service '97	024396	1
8	Screw M4x16 5,8-B Zinc Lock	F81011-42	4
9	Washer, 4.3 Flat Zinc	F81051-2	4
10	Nut, M4-B Hex Nylon Zinc Lock	F81029-1	4
11	Grommet, 22mm Rubber	087400	1
12	Grommet, 20/13 Rubber	086188	1
13	Button, XB4 BS542 Emergency Stop	086556	1
14	Washer, ZBY9330 Emergency Stop Button	086561	1
15	Contact, ZBE102	086810	1
16	Solenoid, 120-943 Hyd Shut-Off	P10449	1
17	Bolt, M6x40mm, Hex Head, Full Thrd, Zinc	F81001-5	1

18	Bolt, M6x16mm, Hex Head, Full Thrd, Zinc	F81001-15	6	
19	Washer, M6 Star Lock Zinc	F81053-2	2	
20	Washer, M6 Flat Zinc	F81053-1	8	
21	Nut, M6 Hex Nylon Lock Zinc	F81031-2	5	
22	Radiator, Diode	091867	1	
23	Spacer, P3/12	R80671-2	4	
24	Cover Weldment, LT20 Complete	097135-1	1	
25	Bolt, #10-24x1/2 Ph Pan Hd, Type 23	F05015-17	6	
26	Capacitor, 10000/63V Elektrolytic	091166	1	
27	Solenoid, 200A 12V DPST	015417	2	
	Panel, LT20DC Front Complete	097163	1	
28	Panel, LT20/40DC Front	100573-1	1	
29	Decal, LT20DC Control Box Left	099592	1	
30	Decal, LT20AC/DC Control Box Right	099593	1	
31	Switch, Key	P04350	1	
32	Knob, Speed Control	P06257	1	
33	Potentiometer, 1k	E20519	1	
34	Meter, Hour	093166	1	
35	Gasket, Hour Meter	093346	1	
36	Bolt, M3x12-8.8 Zinc	F81000-12	2	
37	Nut, M3-6 Hex Nylon Zinc Lock	F81028-2	2	
38	Switch, SPST On/Off 15A .25 Tabs Toggle	P03027	1	
39	Switch, DPDT Toggle 21A Rev Mom Spade	024200	2	
40	Washer, 1/2x3/4x1/16 Nylon	P05251-1	3	
41	Boot, Toggle Switch	P02575	3	
42	Gasket, LT20 Control Box	097132	1	
43	Bolt, #10-24x1/2 Ph Pan Hd, Type 23	F05015-17	10	
44	Controller, SW-10 Setworks	500628	1	
45	Screw, FH ST 3,5x6,5 A4	F81000-82	6	
46	Washer, 3.2 Flat Zinc	F81050-2	6	
47	Spacer, 4.2x6mm Idler	R80671-4	6	
48	Light, XB6AV5BB Yellow	089812	1	
49	Light, XB6AV4BB Red	091099	2	
50	Light, XB6AV3BB Green	087348	1	
51	Cap, SR1086 22.2 Dia. Hole	093544	1	

4.9 Drum Switches

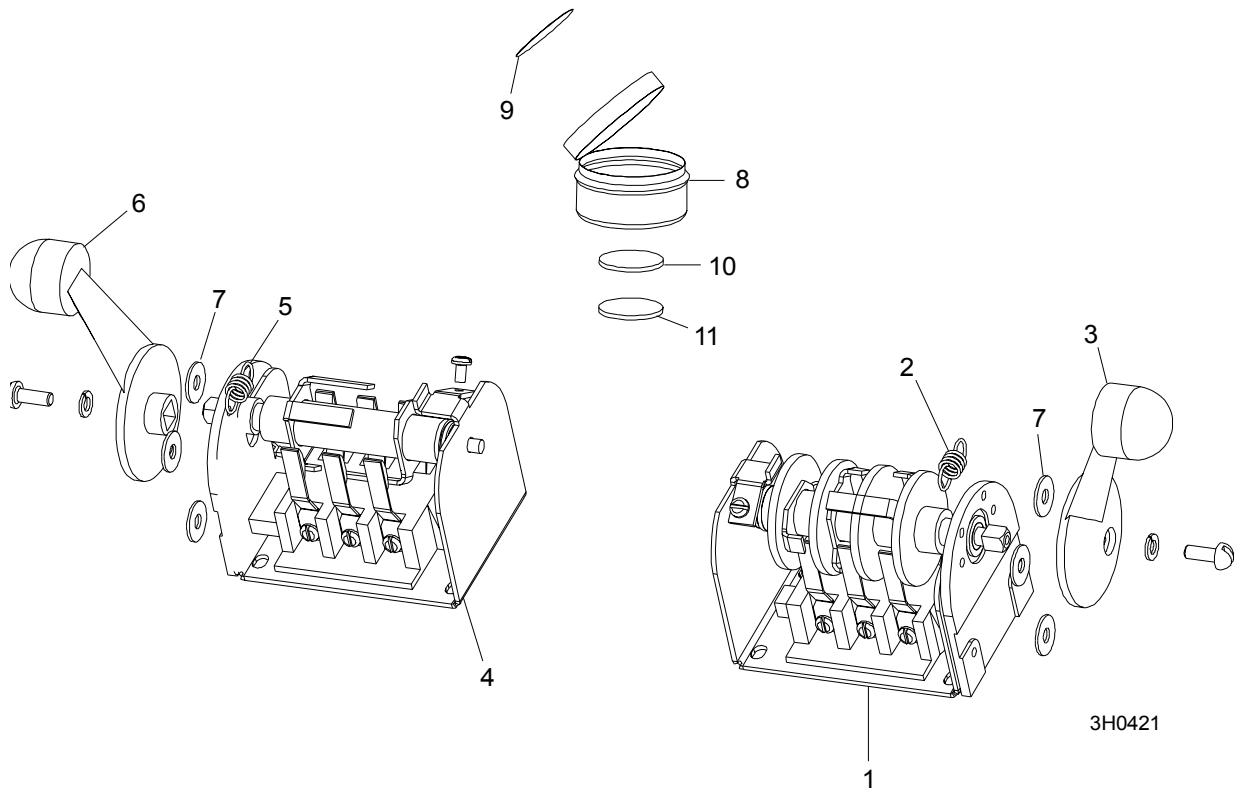

REF	DESCRIPTION (◆ Indicates Parts Available In Assemblies Only)	PART #	QTY.	
	SWITCH ASSEMBLY, UP/DOWN DRUM	E20440	1	
1	Switch, Drum	E20440-B	1	◆
2	Spring, Drum Switch	P12570	1	
3	Handle, Drum Switch w/Screws	P12500	1	
	SWITCH ASSEMBLY, POWER FEED DRUM	E20438	1	
4	Switch, Drum	E20438-B	1	◆
5	Spring, Drum Switch	P12570	1	
6	Handle, Drum Switch w/Screws	P12500	1	
7	WASHER, #8 SAE FLAT	F05011-41	6	
	CUP ASSEMBLY, DRUM SWITCH GREASE	A20463	1	
8	Cup, Plastic Container	P20464	1	◆
9	Label, Grease Cup	P20467	1	
10	Pad, Velcro Loop	P20466	1	◆
11	Pad, Velcro Hook	P20465	1	◆
	Grease, Drum Switch	P20468	.011ml	◆

4.10 Sawdust Chute

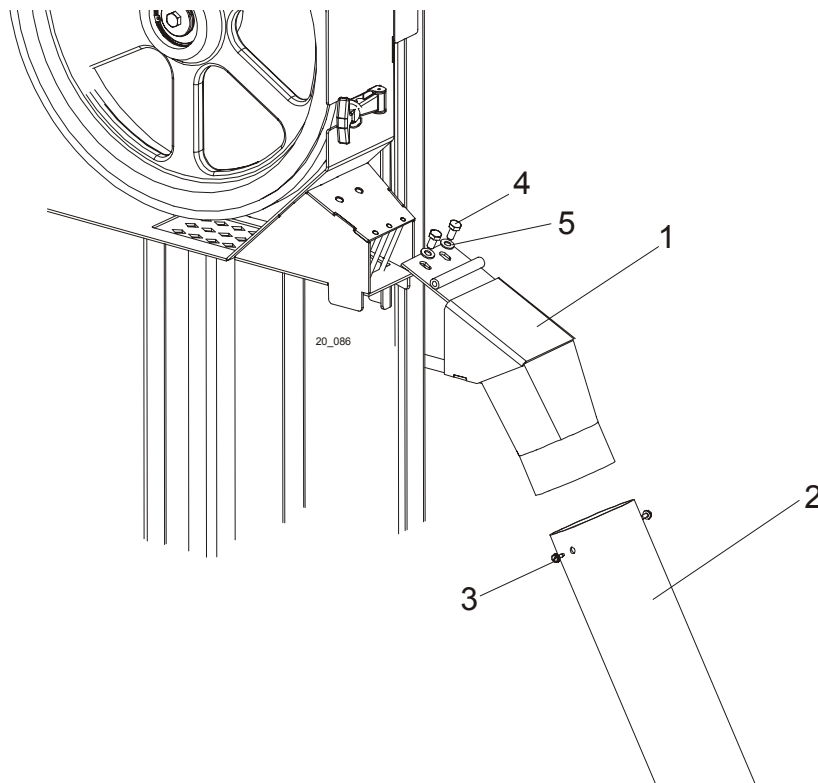

REF	DESCRIPTION (◆ Indicates Parts Available In Assemblies Only)	PART #	QTY.
1	CHUTE WELDMENT, SAWDUST	100903-1	1
2	TUBE, SAWDUST CHUTE RUBBER	R02336	1
3	SCREW, #10-24 X 1/2 SELF-TAPPING	F05015-7	2
4	BOLT, M8x16	F81002-20	2
5	WASHER, 8.4 ZINC FLAT	F81054-1	2

4.11 Up/Down Cable Chain Assembly

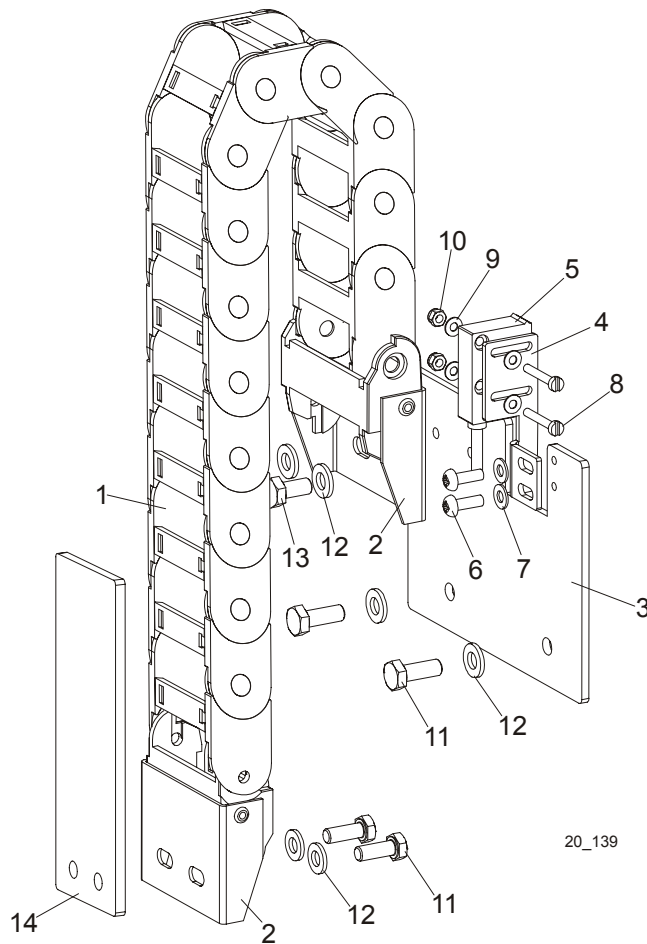

REF	DESCRIPTION (◆ Indicates Parts Available In Assemblies Only)	PART #	QTY.
	HARNESS GUIDE AND SENSOR ASSEMBLY	098052	1
1	Harness Guide, SR300A 050 080	097924	1
2	Bracket, AN300A 050K Mount	097925	1
3	Mounting Plate, Harness and Sensor Assy.	096067-1	1
4	Bracket, Sensor Mount	096068-1	1
5	Sensor, MSK-320	096014	1
6	Screw, M4x12-5,8-B Zinc	F81011-43	2
7	Washer, 4.3 Zinc	F81051-2	2
8	Screw, M3x20-5.8-A Zinc	F81000-8	2
9	Washer, 3.2 Zinc	F81050-2	4
10	Nut, M3-6 Zinc	F81028-2	2
11	Bolt, M6x20-8.8 Hex Head Zinc	F81001-2	4
12	Washer, 6.4 Zinc	F81053-1	6
13	Bolt, M6x12-8.8 Hex Head Zinc	F81001-7	2
14	Plate, Guide Mount	098662-1	1

SECTION 5 UP/DOWN ASSEMBLY

5.1 Up/Down Assembly, AC Mills

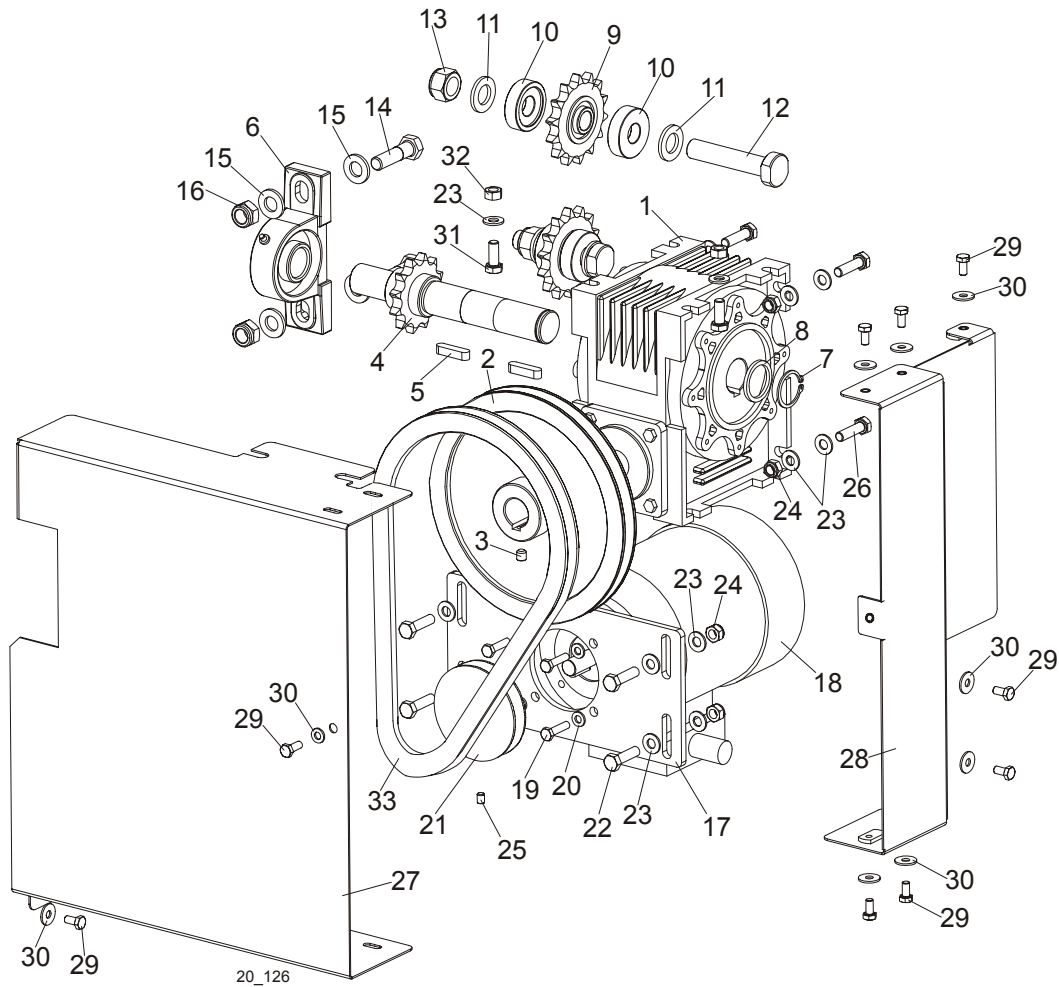

REF	DESCRIPTION (◆ Indicates Parts Available In Assemblies Only)	PART #	QTY.	
	MOTOR ASSEMBLY, LT20 AC UP/DOWN	098300	1	◆
	Motor Assembly, LT20 Up/Down	098299	1	
1	Box, R-63/66/F1/B3 Gear	097786	1	
2	Pulley, LT20	091078-1	1	
3	Screw, M8x8-33H Hex Socket Set Flat Point	F81014-1	1	
4	Shaft, LT20 Up/Down w/Sprocket	098298	1	
5	Key, A8x7x32 Parallel	088564	2	
6	Bearing Assembly, UCP 205CX	088468	1	
7	Ring, Z28 Spring Retaining	F81090-12	1	
8	Washer	098351	1	
	Shaft Assembly	098353	2	
9	Sprocket, KSR 16.LO.10.10.14.08 w/Bearing	088867	1	
10	Spacer, Drive Bearing	098166	2	
11	Washer, M16, Flat Zinc	F81058-1	2	
12	Pin, Up/Down Drive Shaft	098289-1	1	
13	Nut, M16, Hex, Nylon Zinc Lock	F81036-2	1	

14	Bolt, M12x45-8.8 Zinc Lock	F81004-32	2	
15	Washer, M12, Flat Zinc	F81056-1	4	
16	Nut, M12 ,Hexagon, Nylon, Zinc, Lock	F81034-2	2	
	Motor Assembly, LT20 AC Up/Down	091302	1	
17	Plate, LT20 AC Up/Down Motor Mount Ptd	098355-1	1	
18	Motor, SKh 71- 4B2 RAL 9005	091304	1	
19	Bolt, M6x25mm, Hex Head, Gr 8.8, Zinc	F81001-3	4	
20	Washer, M6, Flat Zinc	F81053-1	4	
21	Pulley, LT20 Gear Box	090699-1	1	
22	Bolt, M8x30mm,HH,Gr 5.8, Full Thrd, Zinc	F81002-2	4	
23	Washer, M8, Flat Zinc	F81054-1	18	
24	Nut, M8, Hexagon, Nylon Lock Zinc	F81032-2	8	
25	Screw, M6x8-33H Hex Socket Set Flat Point	F81013-1	1	
26	Bolt, M8x30-8.8-B-Fe/Zn5 PN-M82105	F81002-7	4	
27	Guard, Up/Down System Front	098393-1	1	
28	Guard, Up/Down System Side Complete	098395-1	1	
29	Bolt, M6x12mm Hex Head Zinc	F81001-7	9	
30	Washer, 6.5 Flat Special Zinc-Plated	F81053-11	9	
31	Bolt, M8x20mm,HH,GR 8.8, Full Thrd, Zinc	F81002-1	2	
32	Nut, M8 Hexagon, Grade 5.8 Free Zinc	F81032-1	2	
33	Belt, HA-800 (Kleberg)	091086	1	

5.2 Up/Down Assembly, DC Mills

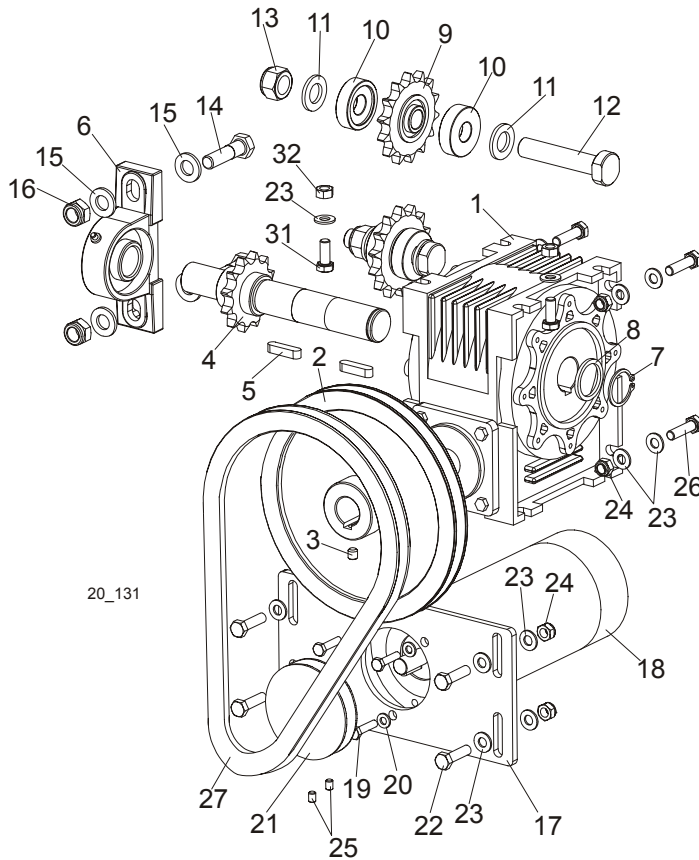

REF	DESCRIPTION (◆ Indicates Parts Available In Assemblies Only)	PART #	QTY.	
	MOTOR ASSEMBLY, LT20 DC UP/DOWN	098346	1	◆
	Motor Assembly, LT20 Up/Down	098299	1	
1	Box, R-63/66/F1/B3 Gear	097786	1	
2	Pulley, LT20	091078-1	1	
3	Screw, M8x8-33H Hex Socket Set Flat Point	F81014-1	1	
4	Shaft, LT20 Up/Down w/Sprocket	098298	1	
5	Key, A8x7x32 Parallel	088564	2	
6	Bearing Assembly, UCP 205CX	088468	1	
7	Ring, Z28 Spring Retaining	F81090-12	1	
8	Washer	098351	1	
	Shaft Assembly	098353	2	
9	Sprocket, KSR 16.LO.10.10.14.08 w/Bearing	088867	1	
10	Spacer, Drive Bearing	098166	2	
11	Washer, M16, Flat Zinc	F81058-1	2	
12	Pin, Up/Down Drive Shaft	098289-1	1	
13	Nut, M16, Hex, Nylon Zinc Lock	F81036-2	1	
14	Bolt, M12x45-8.8 Zinc Lock	F81004-32	2	
15	Washer, M12, Flat Zinc	F81056-1	4	
16	Nut, M12 ,Hexagon, Nylon, Zinc, Lock	F81034-2	2	
	Motor Assembly, LT20 AC Up/Down	091303	1	

17	Plate, LT20 DC Up/Down Motor Mount Ptd	098363-1	1	
18	Motor, 12V 0.5HP Drive	006747	1	
19	Bolt, 1/4-20x3/4 FT HHC	F05005-1	3	
20	Washer, M6, Flat Zinc	F81053-1	3	
21	Pulley, "A" 82/12,7 Gear Box	093158-1	1	
22	Bolt, M8x30mm,HH,Gr 5.8, Full Thrd, Zinc	F81002-2	4	
23	Washer, M8, Flat Zinc	F81054-1	18	
24	Nut, M8, Hexagon, Nylon Lock Zinc	F81032-2	8	
25	Screw, M6x8-33H Hex Socket Set Flat Point	F81013-1	2	
26	Bolt, M8x30-8.8-B-Fe/Zn5 PN-M82105	F81002-7	4	
27	Belt, HA-800 (Kleberg)	091086	1	

5.3 Up/Down Chain Tensioner Assembly

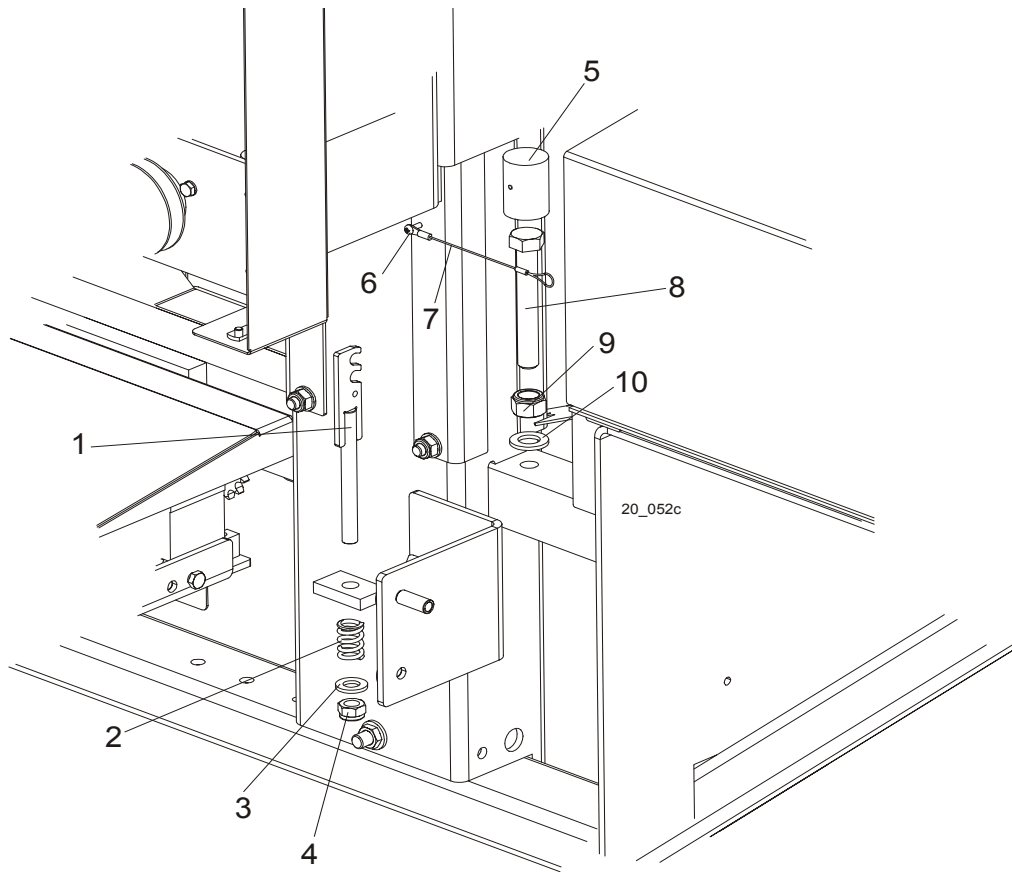

REF	DESCRIPTION (◆ Indicates Parts Available In Assemblies Only)	PART #	QTY.
1	TENSIONER WELDMENT, LT20 UP/DOWN CHAIN ZINC-PLATED	090730-1	1
2	SPRING, 14 X 30 X 3.2	090797	1
3	WASHER, 13 ZINC FLAT	F81056-1	1
4	NUT, M12-8 HEX NYLON ZINC LOCK	F81034-2	1
	BLOCK, HEAD SUPPORTING, COMPLETE	097775	1
5	Block, Head Support, ptd	097771-1	1
6	Screw M4x12 -5,8-B- Fe/Zn5 PN-M/82202	F81011-43	1
7	Lanyard, 3/64 x 6	016030	1
8	BOLT M16X110-8.8	F81006-24	1
9	NUT, M16,HEX, NYLON ZINC LOCK	F81036-2	1
10	WASHER, M16,FLAT ZINC	F81058-1	1
	UP/DOWN CHAIN, LT20 TYPE 10B-1-111	098451	1

5.4 Battery Box Assembly, DC Mills

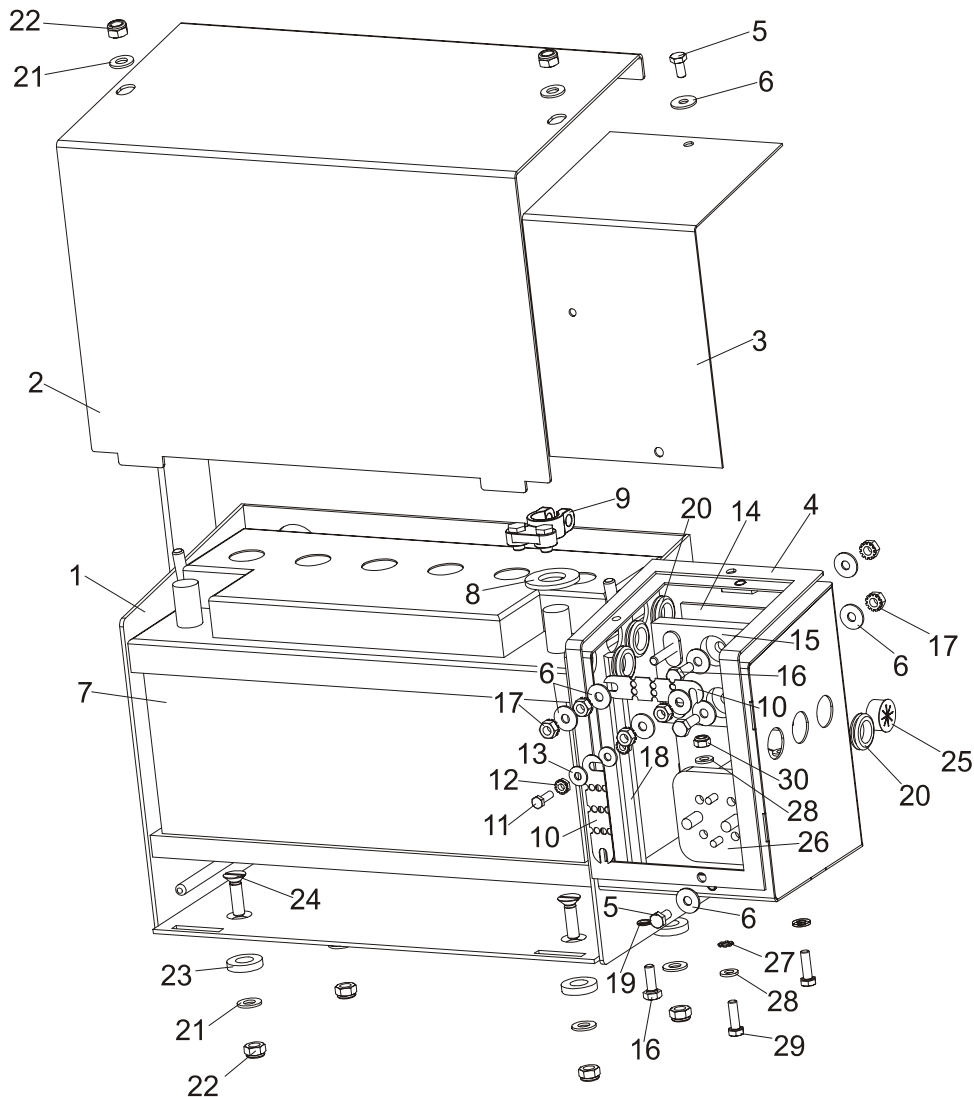

REF	DESCRIPTION (◆ Indicates Parts Available In Assemblies Only)	PART #	QTY.	
	BATTERY BOX, LT20 COMPLETE	097490	1	
1	Battery Box, LT20	097486-1	1	
2	Lid, Battery Box	097489-1	1	
3	Lid, Fuse Box	092222-1	1	
4	Gasket, Fuse Box	092226	1	
5	Bolt, M6x12mm Hex Head Zinc	F81001-7	2	
6	Washer, 6.5 Split Lock Zinc	F81053-11	10	
7	Battery, "Banner" 12V 100Ah #95751	088323	1	
8	Washer, Battery Terminal	P12161	1	
9	Terminal, Battery	P05085	1	
10	Fuse, 150A 12V Link	023361	2	
11	Screw, 10-24x5/8 Unsl Indent HH Machine	F05004-18	1	
12	Nut, #10-24 Keps	F05010-14	2	
13	Washer, 5.5 Split Lock Zinc	F81052-3	2	
14	Plate, 1/8 Plasic Fuse Box	015287	1	

15	Block Assy, Fuse, High Amp	017665	1	
16	Bolt, 1/4-20x3/4 FT HHC	F05005-1	3	
17	Nut, 1/4-20 Self Locking Zinc	F05010-9	6	
18	Nut, Fuse Stud Extended	015517	1	
19	Washer, M6 Split Lock Zinc	F81053-3	1	
20	Grommet, 5/8 ID Rubber	P11764	3	
	Grommet, SR170P No.462041	098816	1	
21	Washer, M8 Flat Zinc	F81054-1	6	
22	Nut, M8 Hexagon Nylon Lock Zinc	F81032-2	6	
23	Spacer, SR 1941 Idler	R80671-5	4	
24	Bolt, M8x30-5.8-B Zinc	F81002-37	4	
25	Grommet, Heyco Wire	P04137	1	
26	Solenoid, 200A 12V SPST Hyd. Pump 1997	015470	1	
27	Washer, M6 Star Lock Zinc	F81053-2	1	
28	Washer, M6 Flat Zinc	F81053-1	4	
29	Bolt, M6x20mm, HH, Full Thread, Zinc	F81001-2	2	
30	Nut, M6 Hex Nylon Lock Zinc	F81031-2	2	

SECTION 6 UP/DOWN ROLLERS & BLADE HEIGHT SCALE

6.1 Up/Down Rollers

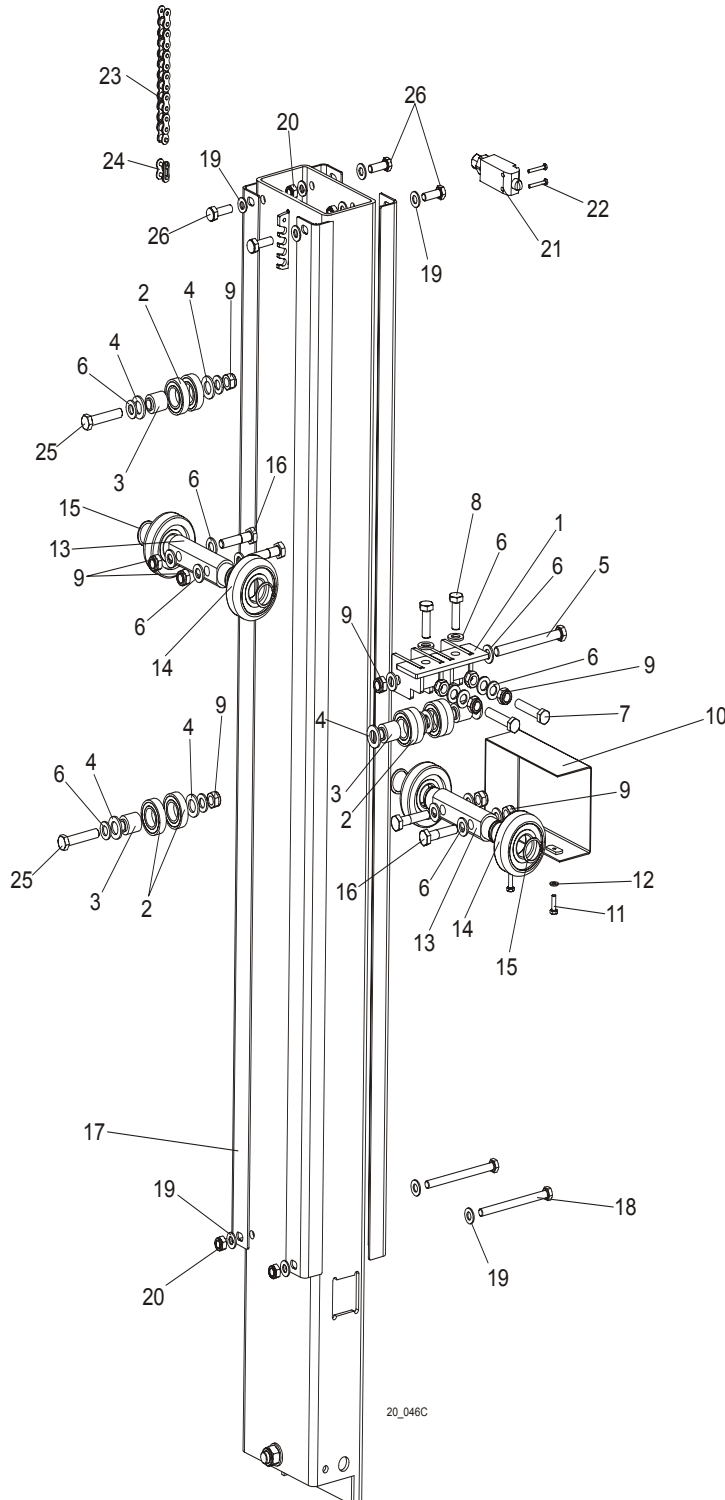

20_046C

REF	DESCRIPTION (◆ Indicates Parts Available In Assemblies Only)	PART #	QTY.
1	BRACKET WELDMENT, LT20 UP/DOWN ROLLER PTD	091095-1	1
2	BEARING, 6005 2RS CX	089652	8

3	BUSHING, LT20 UP/DOWN ROLLER	090790	4	
4	WASHER, 17 ZINC FLAT	F81058-1	10	
5	BOLT, M12 X 120 8.8 HEX HEAD ZINC	F81004-38	1	
6	WASHER, 13 ZINC FLAT	F81056-1	20	
7	BOLT, M12 X 60-8.8 HEX HEAD FULL THREAD ZINC	F81004-51	2	
8	BOLT, M12 X 40-8.8 HEX HEAD FULL THREAD ZINC	F81004-4	2	
9	NUT, M12-8 HEX NYLON ZINC LOCK	F81034-2	11	
10	GUARD, LT20 UP/DOWN ROLLERS PTD	091619-1	1	
11	BOLT, M6 X 20-8.8 HEX HEAD FULL THREAD ZINC	F81001-2	2	
12	WASHER, 6.4 ZINC FLAT	F81053-1	2	
13	SHAFT, UP/DOWN ROLLERS ZINC-PLATED	090616-1	2	
14	ROLLER, CBK-468	088433	4	
15	RING, Z30 SPRING RETAINING	F81090-23	4	
16	BOLT, M12 X 55-8.8 HEX HEAD FULL THREAD ZINC	F81004-43	4	
17	ANGLE, LT20 MAST TUBE	091182	4	
18	BOLT, M10 X 125-8.8 HEX HEAD ZINC	F81003-18	2	
19	WASHER, 10.5 ZINC FLAT	F81055-1	22	
20	NUT, M10-8-B HEX NYLON ZINC LOCK	F81033-1	10	
21	SWITCH, GLCB01C LIMIT	100910	1	
22	BOLT, M4 X 30 8.8 HEX HEAD FULL THREAD ZINC	F81011-5	2	
23	CHAIN, LT20 10B-1-111 TYPE UP/DOWN	098451	1	
24	LINK, 10B-1PZ MASTER	088671	1	
25	BOLT, M12X60MM, HEX HEAD GR 8.8	F81004-5	2	
26	BOLT, M10X25-8.8-FE/ZN5	F81003-11	4	

6.2 Blade Height Scale

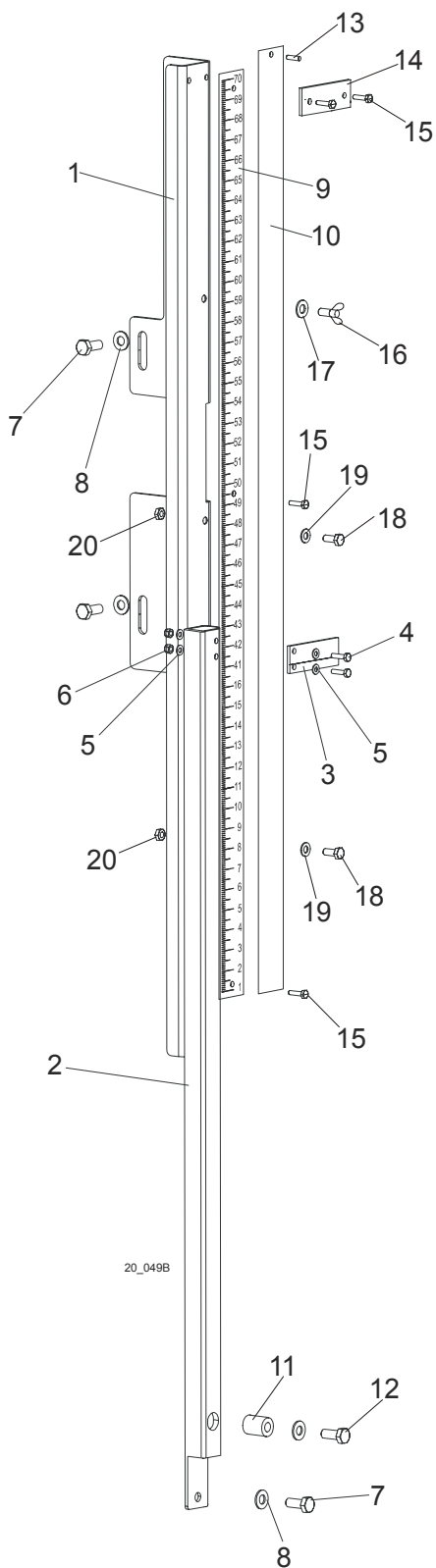

REF	DESCRIPTION (◆ Indicates Parts Available In Assemblies Only)	PART #	QTY.	
1	BRACKET, SCALE MOUNT PTD	092749-1	1	
2	BRACKET, SCALE INDICATOR MOUNT PTD	092751-1	1	

3	INDICATOR, BLADE HEIGHT SCALE	094821	1	
4	BOLT, M4 X 16 5.8 HEX HEAD FULL THREAD ZINC	F81011-6	2	
5	WASHER, 4.3 ZINC FLAT	F81051-2	4	
6	NUT, M4-B HEX NYLON ZINC LOCK	F81029-1	2	
7	BOLT, M8 X 20-5.8 HEX HEAD FULL THREAD ZINC	F81002-1	4	
8	WASHER, 8.4 ZINC FLAT	F81054-1	4	
9	BAR, SCALE	092750	1	
	DECAL, LT20 0-80CM METRIC SCALE	091239	1	
10	BAR, INCH SCALE	093133	1	
	DECAL, 45-63CM METRIC	P12040-2	1	
	DECAL, METRIC 16-40MM	P12040-1	1	
11	BUSHING, SPACER	092008-1	1	
12	BOLT, M8 X 45 - 8.8 Fe/Zn5, PN-M/82105	F81002-14	1	
13	PIN, 3x20 ROLL ZINC	F81044-5	1	
14	BAR, SCALE MOUNT	093134	1	
15	SCREW, M6x20- 4.8-B Fe/Zn5 PN-85/M-82207	F81001-31	1	
16	BOLT, M6X16 BN276	F81001-16	1	
17	WASHER, FLAT ZINC	F81053-11	1	
18	BOLT, M6X20MM, HH, FULL THREAD, ZINC	F81001-2	2	
19	WASHER, M6, FLAT,ZINC	F81053-1	2	
20	NUT, M6, HEX,NYLON LOCK ZINC	F81031-2	2	

6.3 Limit Switches

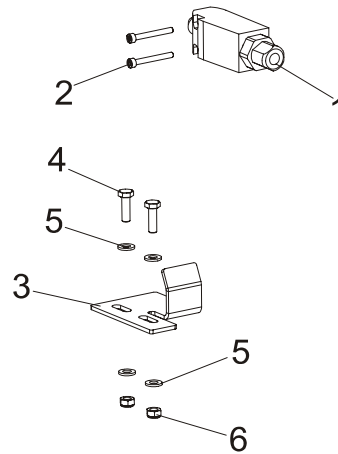

20_133

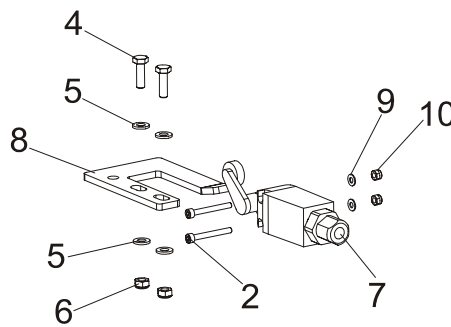

REF	DESCRIPTION (◆ Indicates Parts Available In Assemblies Only)	PART #	QTY.	
1	SWITCH, GLCB01C LIMIT	100910	1	
2	SCREW, M4x35-8.8 HEX SOCKET HEAD CAP ZINC	F81011-34	4	
3	BRACKET, LIMIT SWITCH	091682-1	1	
4	BOLT, M6X20MM, HH, FULL THREAD, ZINC	F81001-2	4	
5	WASHER, M6 FLAT ZINC	F81053-1	8	
6	NUT, M6 HEX NYLON LOCK ZINC	F81031-2	4	
7	SWITCH, GLCB01A1B LIMIT	100931	1	
8	BRACKET, LIMIT SWITCH	091852-1	1	
9	WASHER, M4 FLAT ZINC	F81051-2	2	
10	NUT, M4 HEX NYLON LOCK ZINC	F81029-1	2	

SECTION 7 POWER FEED & TRACK ROLLERS

7.1 Power Feed Assembly, AC Mills

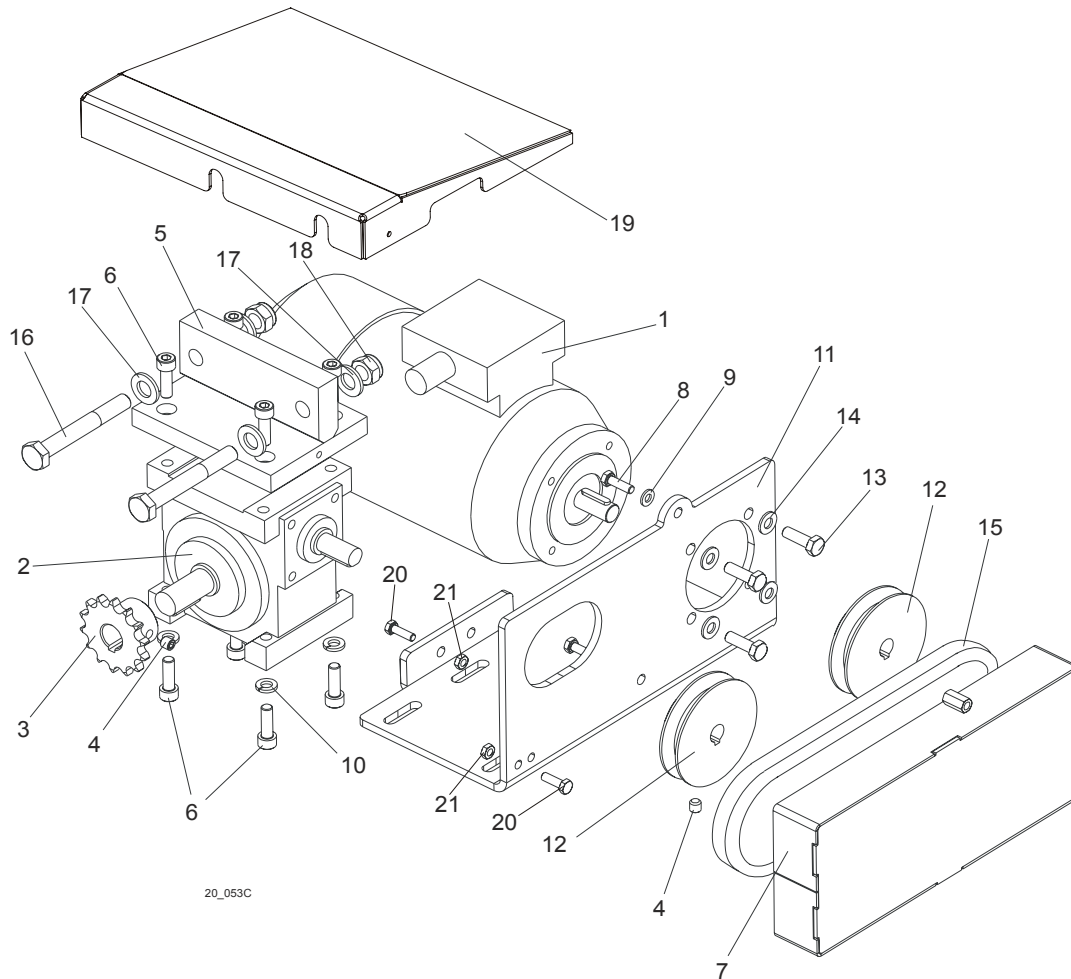

REF	DESCRIPTION (◆ Indicates Parts Available In Assemblies Only)	PART #	QTY.
	POWER FEED ASSEMBLY, LT20 AC	091196	1
1	Motor, Kh71X-2C2, RAL 9005	097313	1
2	Gear Box, RA-04/7.5/D1/N+S/B8 w/Output Shaft	090698	1
3	Sprocket, 10B Z14 Zinc-plated	090702-1	1
4	Screw, M8x8-33H Hex Socket Set Flat Point Zinc	F81014-1	1
5	Bracket, Power Feed Gear Box Mount	090715-1	1
6	Screw, M8X25-8.8 Hex Socket Head Cap Zinc	F81002-21	4
7	Guard, Power Feed Drive Belt	091195-1	1
8	Bolt, M6x20-8.8 Hex Head Full Thread Zinc	F81001-2	2
9	Washer, 6.4 Zinc Flat	F81053-1	2
10	Washer, 8.2 Split Lock Zinc	F81054-4	4
11	Bracket, Power Feed Gear Box	091191	1
12	Pulley, LT20 Power Feed Gear Box Ptd	090699-1	2
13	Bolt, M8x25-8.8-B Hex Head Full Thread Zinc	F81002-5	4
14	Washer, 8.4 Zinc Flat	F81054-1	4
15	V-Belt, HA-560 (STOMIL-SANOK)	088562	1

16	BOLT, M12X90-8.8 HEX HEAD ZINC	F81004-2	2	
17	WASHER, 13 ZINC FLAT	F81056-1	4	
18	NUT, M12-8 HEX NYLON ZINC LOCK	F81034-2	2	
19	GUARD, POWER FEED MOTOR	093780-1	1	
20	BOLT, M8 x 25mm HEX HEAD GR 5.8 ZINC	F81002-5	2	
21	NUT, M8 HEXAGON, GRADE 5.8 FREE ZINC	F81032-1	2	

7.2 Power Feed Assembly, DC Mills

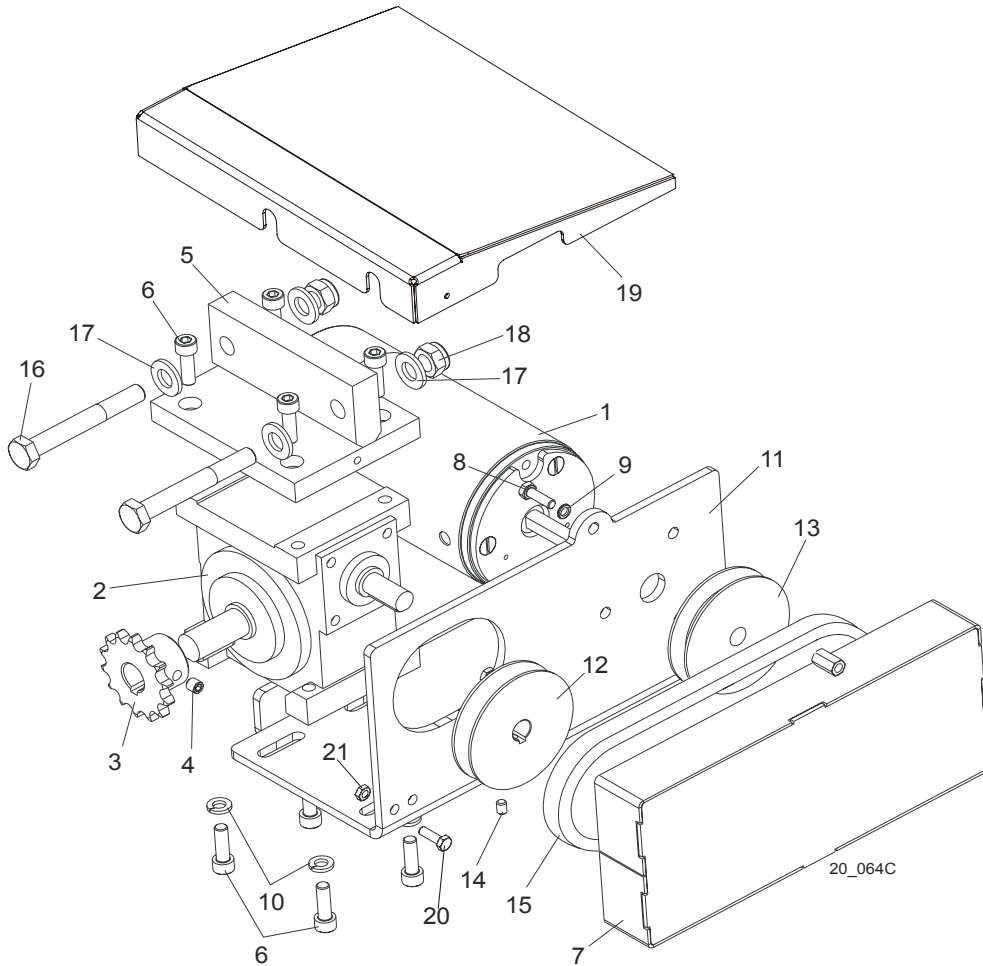

REF	DESCRIPTION (◆ Indicates Parts Available In Assemblies Only)	PART #	QTY.
	POWER FEED ASSEMBLY, LT20 DC	090703	1
1	Motor, 12V 0.5HP	006747	1
2	Gear Box, RA-04/7.5/D1/N+S/B8 w/Output Shaft	090698	1
3	Sprocket, 10B Z14 Zinc-plated	090702-1	1
4	Screw, M8x8-33H Hex Socket Set Flat Point Zinc	F81014-1	1
5	Bracket, Power Feed Gear Box Mount	090715-1	1
6	Screw, M8X25-8.8 Hex Socket Head Cap Zinc	F81002-21	4
7	Guard, Power Feed Drive Belt	091195-1	1
8	Bolt, M6x20-8.8 Hex Head Full Thread Zinc	F81001-2	2
9	Washer, 6.4 Zinc Flat	F81053-1	2
10	Washer, 8.2 Split Lock Zinc	F81054-4	4
11	Bracket, LT20 Power Feed Motor Mount Ptd	090701-1	1
12	Pulley, LT20 Power Feed Gear Box Ptd	090699-1	2
13	Sheave, Up/Down Motor "A" 82/12.7 Ptd	093158-1	1
14	Screw, M6x8 Hex Socket Set Cone Point Zinc	F81013-1	1
15	V-Belt, HA-560 (STOMIL-SANOK)	088562	1
16	BOLT, M12X90-8.8 HEX HEAD ZINC	F81004-2	2
17	WASHER, 13 ZINC FLAT	F81056-1	4
18	NUT, M12-8 HEX NYLON ZINC LOCK	F81034-2	2

19	GUARD, POWER FEED MOTOR	093780-1	1	
20	BOLT, M8 x 25mm HEX HEAD GR 5.8 ZINC	F81002-5	2	
21	NUT, M8 HEXAGON, GRADE 5.8 FREE ZINC	F81032-1	2	

7.3 Upper Track Rollers And Wipers

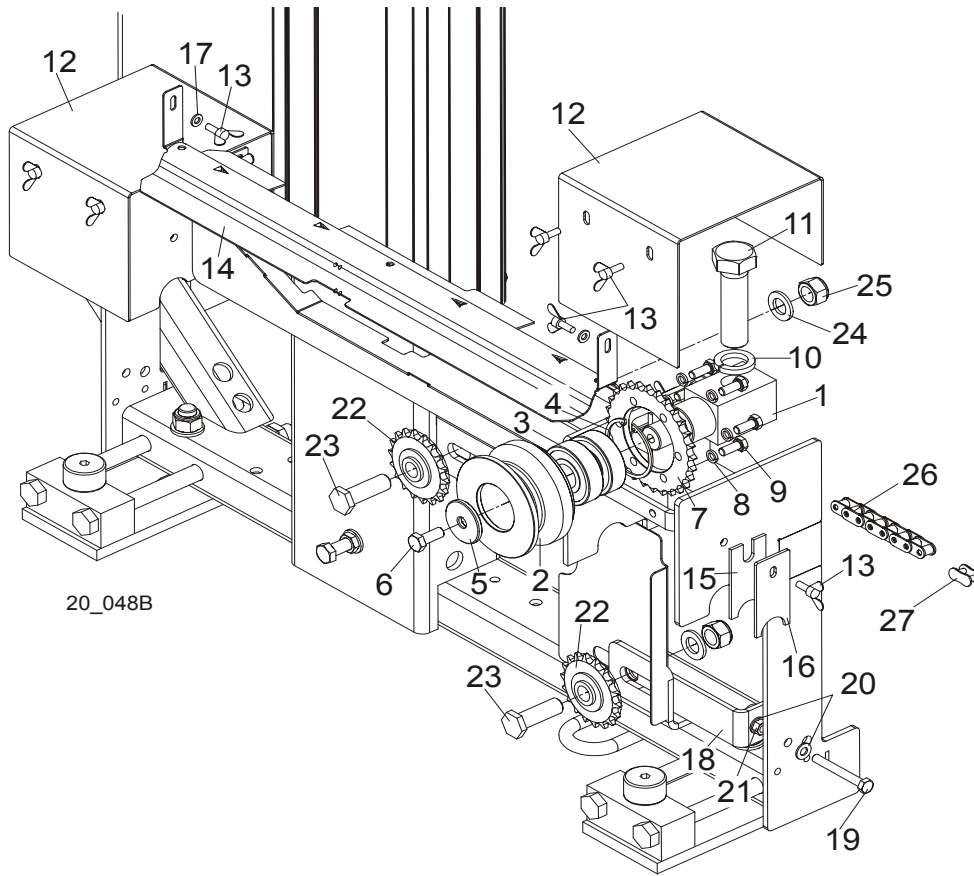

REF	DESCRIPTION (◆ Indicates Parts Available In Assemblies Only)	PART #	QTY.
	ROLLER ASSEMBLY, LT20 UPPER TRACK	090662	2
1	Block, Upper Track Roller Mount	090665	1
2	Roller, Upper Track	090663	1
3	Bearing, 6305 2RS NSK	P08066	2
4	Ring, 2 7/16" Bevelled Snap	F04254-21	1
5	Washer, Drive Wheel	086286	1
6	Bolt, M10x25-8.8 Hex Head Full Thread Zinc	F81003-11	1
7	Sprocket, O8B Z28	090664	2
8	Washer, 8.2 Split Lock Zinc	F81054-4	6
9	Bolt, M8x20-5.8 Hex Head Full Thread Zinc	F81002-1	6
10	WASHER, Z 24.5 SPLIT LOCK ZINC	F81061-4	2
11	BOLT, M24X2X90-8.8 HEX HEAD FULL THREAD ZINC	F81009-2	2
12	GUARD, UPPER TRACK ROLLER	090749-1	2
13	SCREW, M6 X 16 BN276 DIN 316 THUMB	F81001-16	8
14	COVER, LT20 MIDDLE TRACK W/FELT - SERVICE	091656-S	1
	Cover, LT20 Middle Track Ptd	091656-1	1
	Strip, 3/16 X 2 X 23 Felt	S09915	1
15	WIPER, TOP RAIL	M04113	2
16	PLATE, TRACK WIPER PTD	088559-1	2
17	WASHER, 6.4 ZINC FLAT	F81053-1	2

18	TENSIONER, POWER FEET SPROCKET	092862-1	1	
19	BOLT, M8 X 65MM,HH,GRADE 5.8, ZINC	F81002-3	1	
20	WASHER, M8, FLAT, ZINC	F81054-1	2	
21	NUT, M8 HEXAGON,GRADE 5.8 FREE ZINC	F81032-1	1	
22	SPROCKET, IDLER Z=18 KSR16.L0.08.10.18.0	088700	2	
23	BOLT, SPROCKET MOUNT	091744-1	2	
24	WASHER, 17 FLAT ZINC	F81058-1	2	
25	NUT, M16,HEX, NYLON ZINC LOCK	F81036-2	2	
26	CHAIN, LT20 08B-185 TYPE POWER FEED	091624	1	
27	LINK, 08B-1PZ MASTER	091625	1	

7.4 Lower Track Rollers

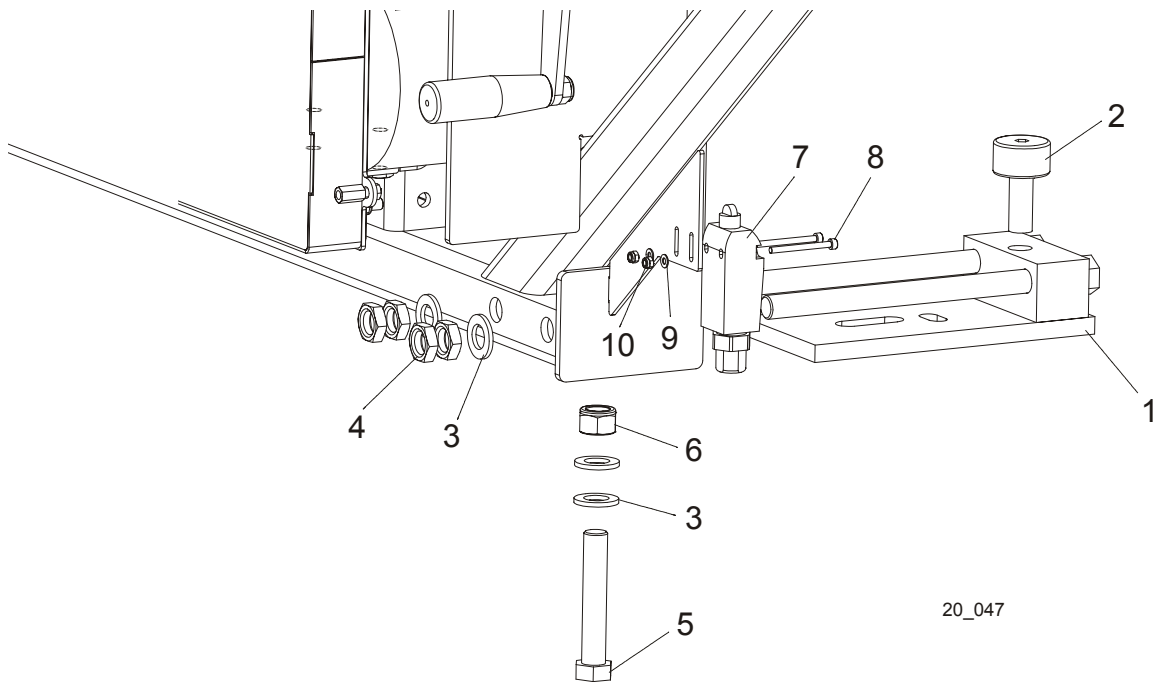

REF	DESCRIPTION (◆ Indicates Parts Available In Assemblies Only)	PART #	QTY.
	ROLLER ASSEMBLY, LT20 LOWER TRACK	090670	2
1	Bracket, LT20 Lower Track Roller	090671-1	1
2	Bearing, Cam Follower (McGill)	012797	1
3	WASHER, 17 ZINC FLAT	F81058-1	4
4	NUT, M16 HEX THIN ZINC	F81036-4	4
5	BOLT, M16 X 90-8.8 HEX HEAD ZINC	F81006-17	1
6	NUT, M16-8 HEX NYLON ZINC LOCK	F81036-2	1
7	SWITCH, GLCB01A1B LIMIT	100931	1
8	SCREW, M4 X 45-8.8 HEX SOCKET HEAD CAP ZINC	F81011-33	2
9	NUT, M4-B HEX NYLON ZINC LOCK	F81029-1	2
10	WASHER, 4.3 ZINC FLAT	F81051-2	2

SECTION 8 BED FRAME ASSEMBLY

8.1 Bed Rail Assembly, Front (S/M type frame)

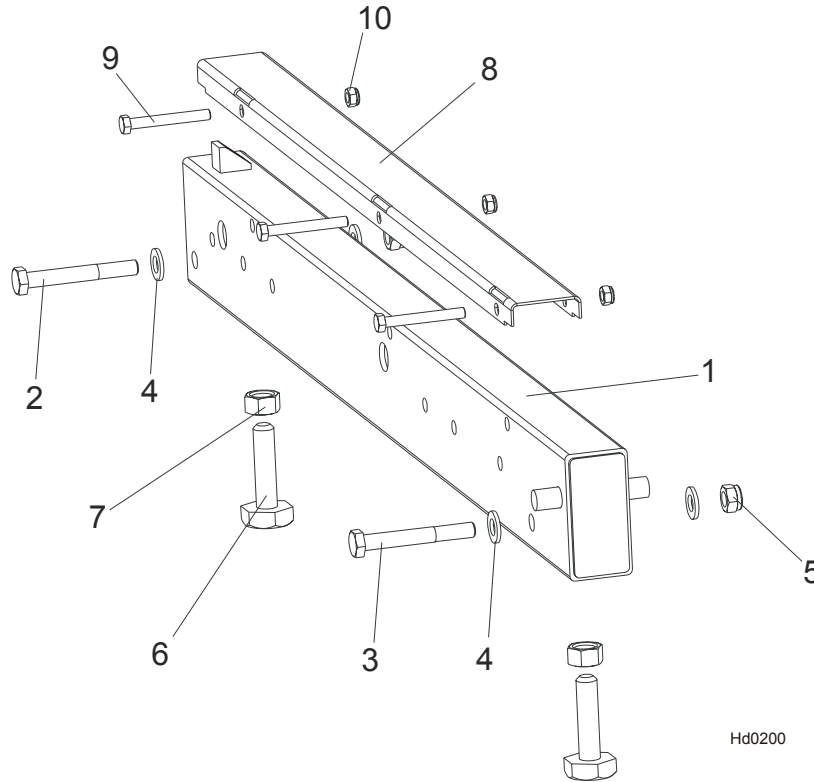

REF	DESCRIPTION (◆ Indicates Parts Available In Assemblies Only)	PART #	QTY.
1	BED RAIL ASSEMBLY, FRONT (S&M FRAME)	099955	1
2	Bolt, M12 x 90-8.8 Hex Head	F81004-2	1
3	Bolt, M12 x 95-8.8 Hex Head	F81004-29	1
4	Washer, 13 SAE Flat	F81056-1	4
5	Nut, M12-8 Hex Nylon Lock	F81034-2	2
	Bed Rail Bolt, Complete (M16 Bolt + 2xNut)	093710	2
6	Bolt, M16, Bed Rail Adjustment	086809	1
7	Nut, M16-5-B Zinc Hex Head	F81036-5	2
8	COVER, STAINLESS STEEL BED RAIL	099124	1
9	BOLT, M8X65-5,8 ZINC HEX HEAD	F81002-3	3
10	NUT, M8-8-B-ZINC HEX NYLON LOCK	F81032-2	3

8.2 Bed Rail Assembly, Rear (S/M type frame)

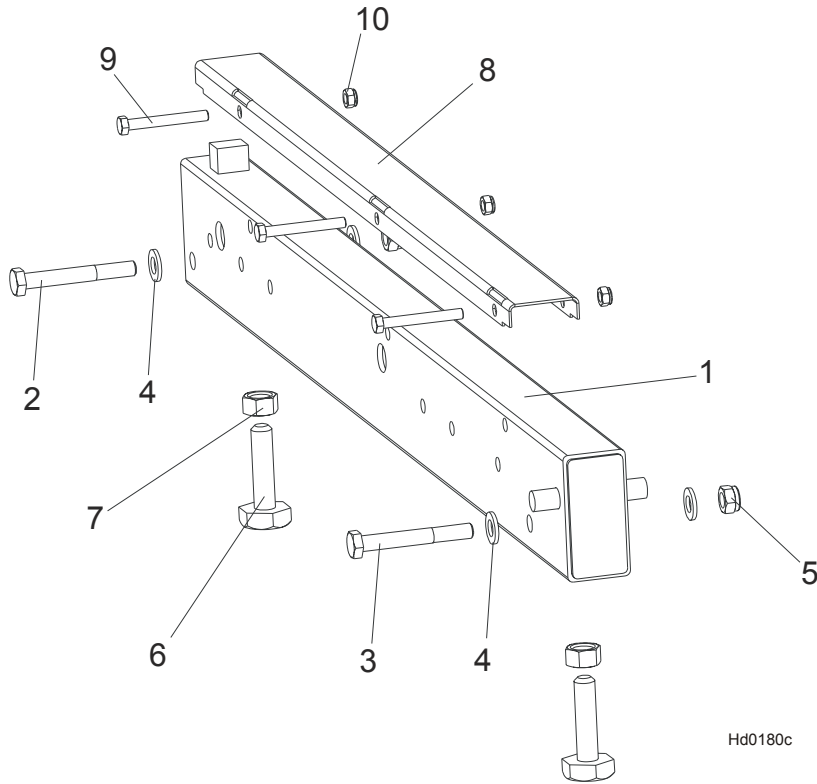

REF	DESCRIPTION (◆ Indicates Parts Available In Assemblies Only)	PART #	QTY.
1	BED RAIL ASSEMBLY, REAR PAINTED	091555	1
2	Bolt, M12 x 90-8.8 Hex Head	F81004-2	1
3	Bolt, M12 x 95-8.8 Hex Head	F81004-29	1
4	Washer, 13 SAE FLAT	F81056-1	4
5	Nut, m12-8 Hex Nylon Lock	F81034-2	2
	Bed Rail Bolt, Complete (M16 Bolt + 2xNut)	093710	1
6	Bolt, M16, Bed Rail Adjustment	086809	1
7	Nut, M16-5-B Zinc Hex Head	F81036-5	2
8	COVER, STAINLESS STEEL BED RAIL	099124	1
9	BOLT, M8X65-5,8 ZINC HEX HEAD	F81002-3	3
10	NUT, M8-8-B-ZINC HEX NYLON LOCK	F81032-2	3

8.3 Bed Rail Assembly, Front Middle (S/M type frame)

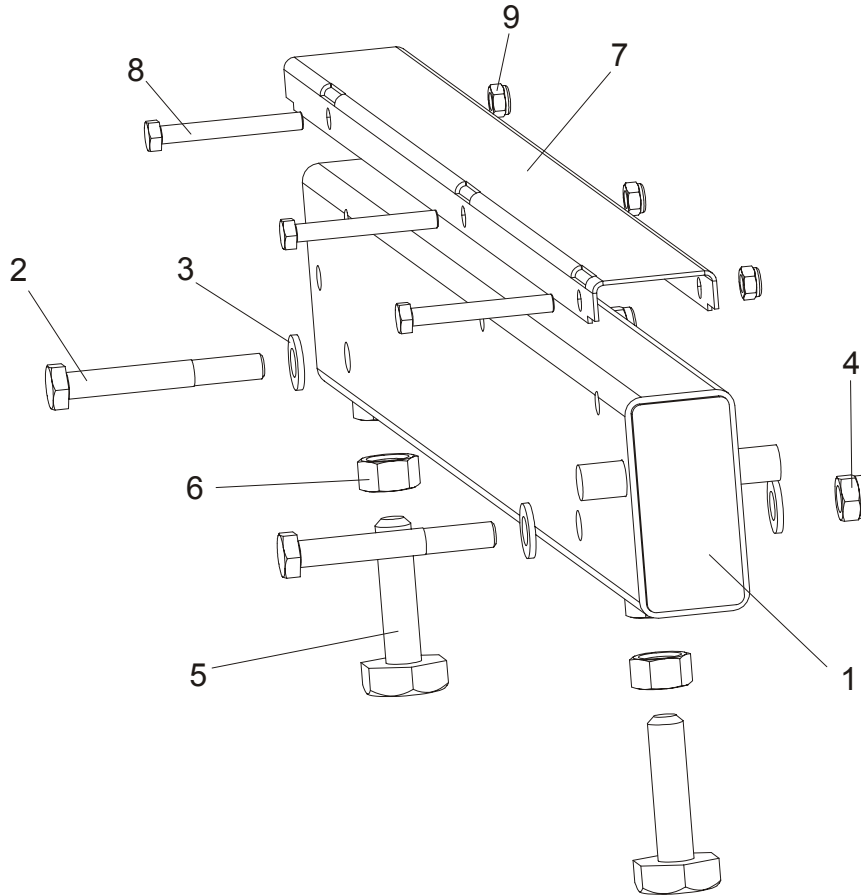

REF	DESCRIPTION (◆ Indicates Parts Available In Assemblies Only)	PART #	QTY.
1	BED RAIL ASSEMBLY, FRONT MIDDLE	091556	1
2	Bolt, M12 x 90-8.8 Hex Head	F81004-2	2
3	Washer, 13 SAE Flat	F81056-1	4
4	Nut, M12-8 hex Nylon Lock	F81034-2	2
	Bed Rail Bolt, Complete (M16 Bolt + 2xNut)	093710	2
5	Bolt, M16, Bed Rail Adjustment	086809	1
6	Nut, M16-5-B Zinc Hex Head	F81036-5	2
7	COVER, STAINLESS STEEL BED RAIL	099124	2
8	BOLT, M8X65-5,8 ZINC HEX HEAD	F81002-3	3
9	NUT, M8-8-B-ZINC HEX NYLON LOCK	F81032-2	3

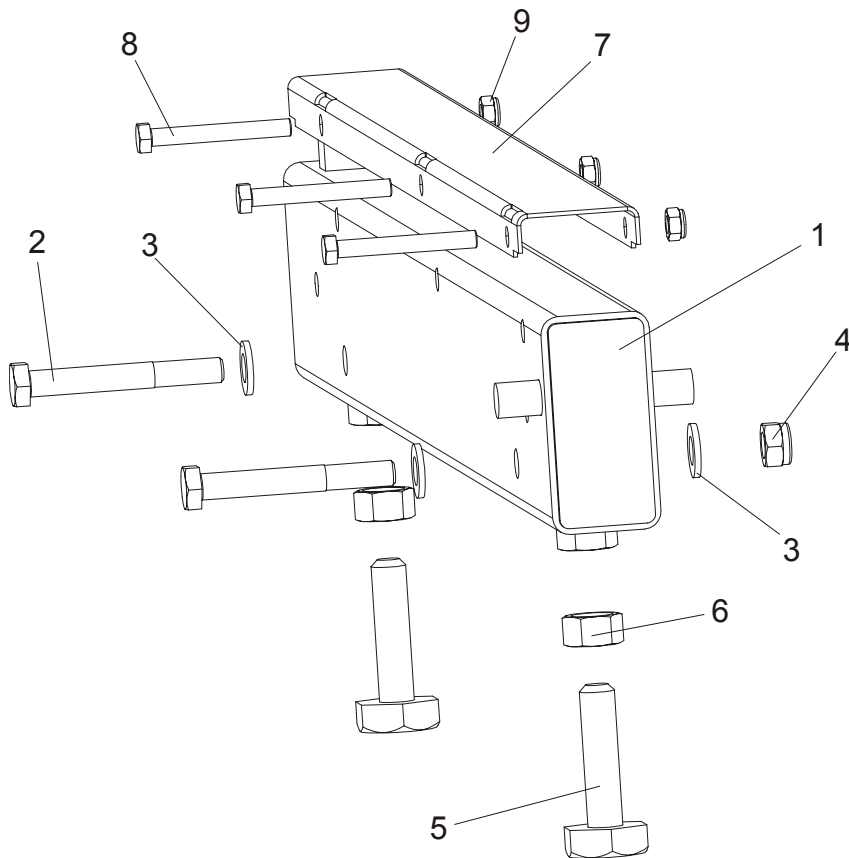
8.4 Bed Rail Assembly, Rear Middle (S/M type frame)

REF	DESCRIPTION (◆ Indicates Parts Available In Assemblies Only)	PART #	QTY.
1	BED RAIL ASSEMBLY, REAR MIDDLE PAINTED	091557	1
2	Bolt, M12 x 90-8.8 Hex Head	F81004-2	2
3	Washer, 13 SAE Flat	F81056-1	4
4	Nut, M12-8 hex Nylon Lock	F81034-2	2
	Bed Rail Bolt, Complete (M16 Bolt + 2xNut)	093710	2
5	Bolt, M16, Bed Rail Adjustment	086809	1
6	Nut, M16-5-B Zinc Hex Head	F81036-5	2
7	COVER, STAINLESS STEEL BED RAIL	099124	1
8	BOLT, M8X65-5,8 ZINC HEX HEAD	F81002-3	3
9	NUT, M8-8-B-ZINC HEX NYLON LOCK	F81032-2	3

8.5 Bed Rail Assembly (L type frame)

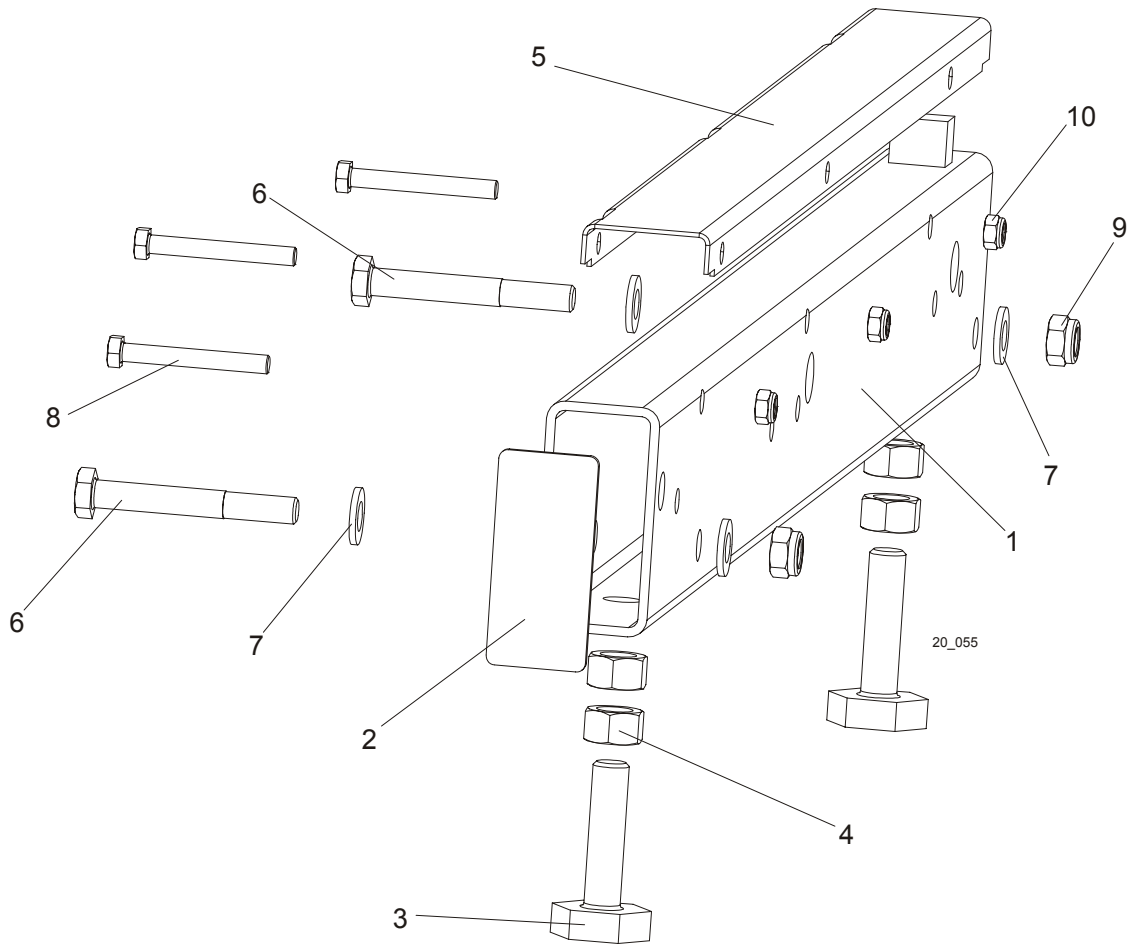

REF	DESCRIPTION (◆ Indicates Parts Available In Assemblies Only)	PART #	QTY.
	LONG BED RAIL ASSEMBLY	089385	1
1	Bed Rail Tube, Long	087433	1
2	Plate, Bed Rail End Cap	087853	1
3	Bolt, Bed Rail Adjustment	S13006	2
4	Nut, 5/8-11 Hex	F05010-54	4
5	Cover, Stainless Steel Bed Rail	099124	1
6	Bolt, M12 x 90-8.8 Hex Head Zinc	F81004-2	2
7	Washer, 13 Zinc Flat	F81056-1	4
8	Bolt, M8x65-5.8 Hex Head Zinc	F81002-3	3
9	Nut, M12-8 Hex Nylon Zinc Lock	F81034-2	2
10	Nut, M8-8-B Hex Nylon Zinc Lock	F81032-2	3

8.6 Bed Rail Assembly (L type frame)

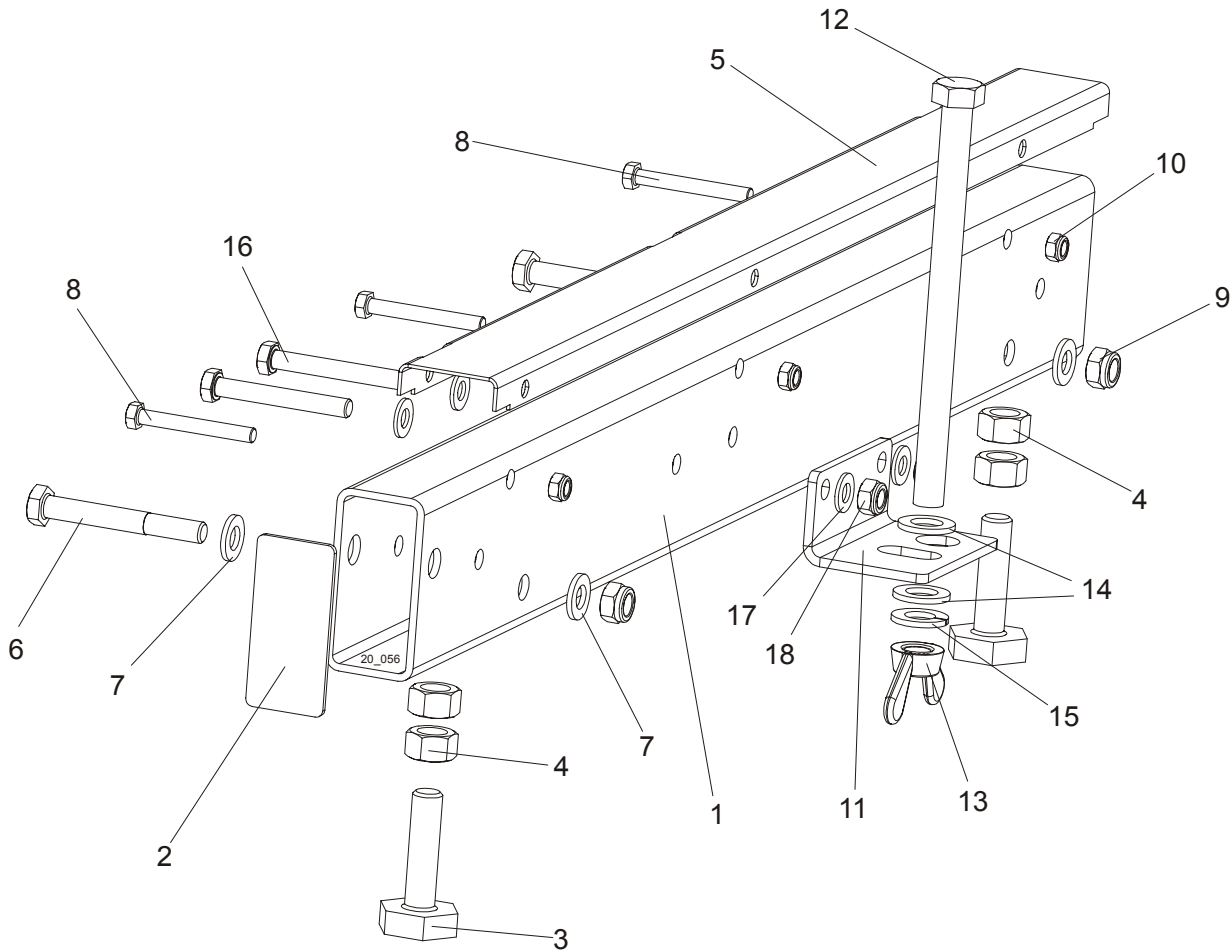

REF	DESCRIPTION (◆ Indicates Parts Available In Assemblies Only)	PART #	QTY.
	BED RAIL ASSEMBLY, SHORT	089386	1
1	Bed Rail Tube, Short	087878	1
2	Plate, Bed Rail End Cap	087853	1
3	Bolt, Bed Rail Adjustment	S13006	2
4	Nut, 5/8-11 Hex	F05010-54	4
5	Cover, Bed Rail Stainless Steel	099124	1
6	Bolt, M12x90-8.8 Hex Head Zinc	F81004-2	2
7	Washer, 13 Zinc Flat	F81056-1	4
8	Bolt, M8x65-5.8 Hex Head Zinc	F81002-3	3
9	Nut, M12-8 Hex Nylon Zinc Lock	F81034-2	2
10	Nut, M8-8-B Hex Nylon Zinc Lock	F81032-2	3
11	Bracket, Loading Arms Link Storage	090258-1	1
12	Bolt, M16x220-8.8-B Hex Head Zinc	F81006-21	1
13	Nut, M16-8 Hex Nylon Zinc Lock	F81036-2	1
14	Washer, 17 Zinc Flat	F81058-1	2
15	Washer, 16.3 Split Lock Zinc	F81058-2	1
16	Bolt, M10x75-8.8 Hex Head Zinc	F81003-15	2
17	Washer, 10.5 Zinc Flat	F81055-1	2
18	Nut, M10-8-B Hex Nylon Zinc Lock	F81033-1	2

8.7 Stationary Leg

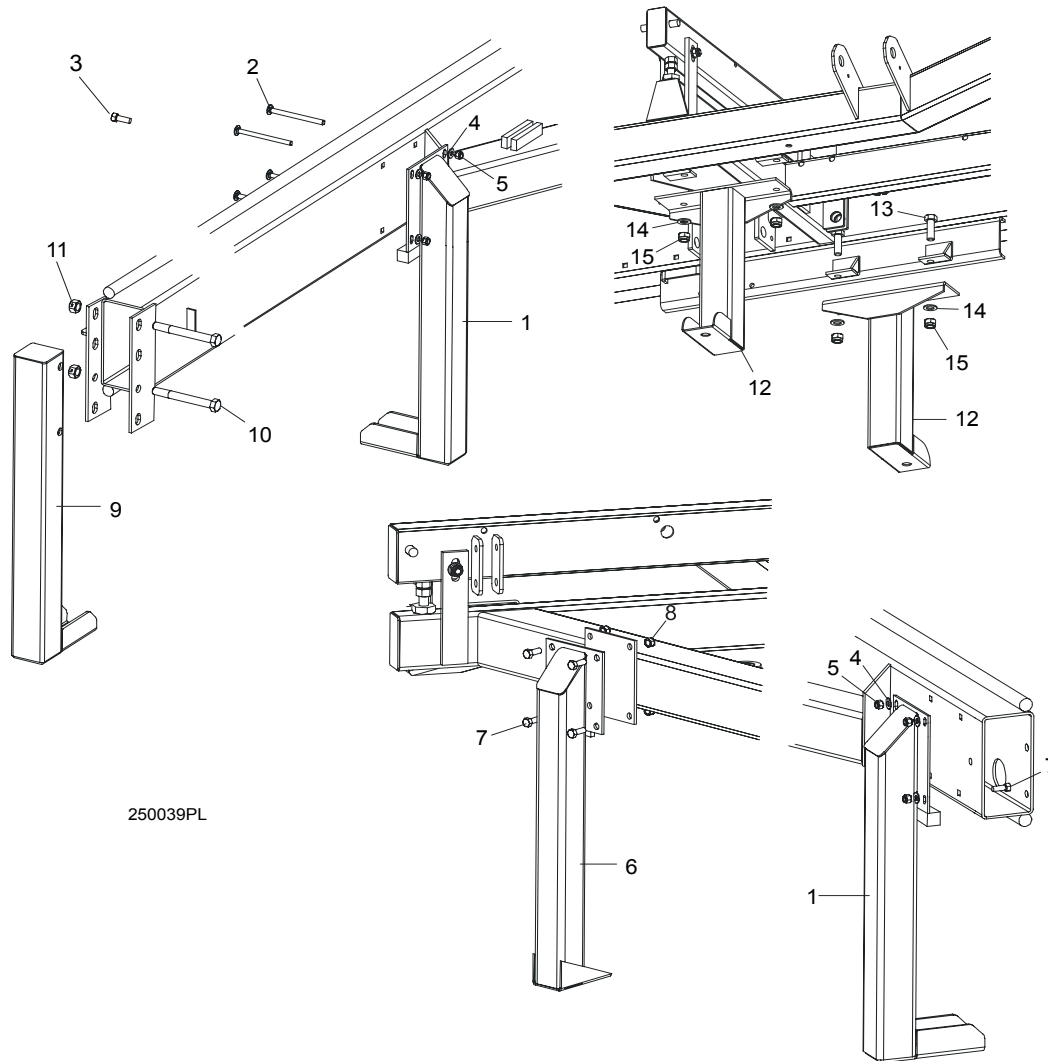

250039PL

REF	DESCRIPTION (◆ Indicates Parts Available In Assemblies Only)	PART #	QTY.
1	LEG, LONG STATIONARY	087451-1	2/3
2	BOLT, M10 X 120 - 8.8 CARRIAGE HEAD ZINC	F81003-33	8
3	BOLT, 3/8-16 X 1" HEX HEAD ZINC GRADE 8	F05007-7	4
4	WASHER, 10.5 ZINC FLAT	F81055-1	16
5	NUT, M10-8-B HEX NYLON ZINC LOCK	F81033-1	8/12
6	LEG, SHORT STATIONARY	087450-1	2
7	BOLT, M10 X 25-8.8 HEX HEAD ZINC	F81003-11	12
8	NUT, M10-8-B HEX NYLON ZINC LOCK	F81033-1	12
9	LEG, FRONT STATIONARY	087452-1	1
10	BOLT, M16 X 140 - 8.8 HEX HEAD	F81006-4	2
11	NUT, 5/8-11 HEX ZINC	F05010-4	2
12	LEG, MIDDLE STATIONARY	087093-1	2
13	BOLT, M16 X 50-8.8 HEX HEAD FULL THREAD ZINC	F81006-7	4
14	WASHER, 17 ZINC FLAT	F81058-1	4
15	NUT, M16-8 HEX NYLON ZINC LOCK	F81036-2	4

8.8 Pivot Bed Rail Assembly

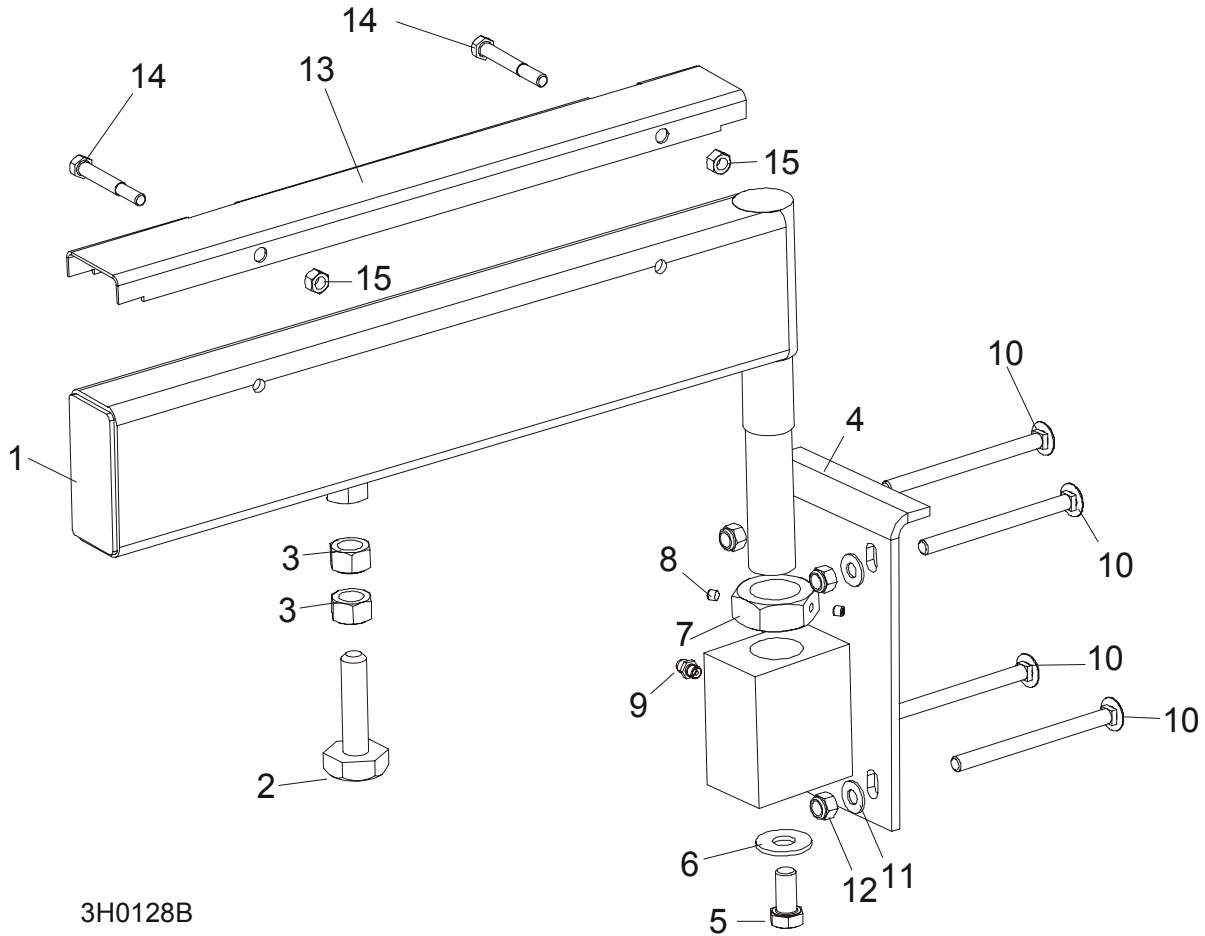

3H0128B

REF	DESCRIPTION (◆ Indicates Parts Available In Assemblies Only)	PART #	QTY.
	PIVOT BED RAIL, COMPLETE	087829	2
	PIVOT BED RAIL, COMPLETE	087855	2
1	Rail Weldment, Pivot Bed	087852-1	1
	Rail, Pivot Bed	087848-1	1
	Bolt Assembly, Bed Rail Adjustment		
2	Bolt, Pivot Bed Rail Adjustment	086809	1
3	Nut, M16-5.8 Zinc Hex	F81036-1	2
4	Bracket, Pivot Bed Rail Mounting	087841-1	1
5	Bolt, M12x25-8.8 Hex Head Full Thread Zinc	F81004-31	1
6	Washer, 9/16" Zinc Flat	F05011-52	1
7	Nut, M16-5.8 Zinc Hex Nut, M32 Zinc Hex Thin	F81036-1 F81039-2	1
8	Screw, 1/4-28 x 1/4 Socket Head Brass Tip Set	F05005-42	2
9	Fitting, M6 Grease	086280	1
10	BOLT, M10 X 120 8.8 CARRIAGE HEAD ZINC	F81003-33	2
11	BOLT, M10 X 120 8.8 CARRIAGE HEAD ZINC	F81003-33	6
12	WASHER, 10.5 ZINC FLAT	F81055-1	8
13	NUT, M16-8 HEX NYLON ZINC LOCK	F81036-2	8
	COVER KIT, PIVOT BED RAIL	015926	2
	COVER KIT, PIVOT BED RAIL	N/A	2

14	Cover, Pivot Bed Rail Stainless Steel	012994	1	
	Cover, Pivot Bed Rail	099123	1	
15	Bolt, M8x65-5.8 Hex Head Zinc	F81002-3	2	
16	Nut, M8-8-B Hex Nylon Zinc Lock	F81032-2	2	
	WRENCH, BED RAIL ADJUSTMENT (Patrz rozdział 8.4)	015970	1	

8.9 Stationary Legs

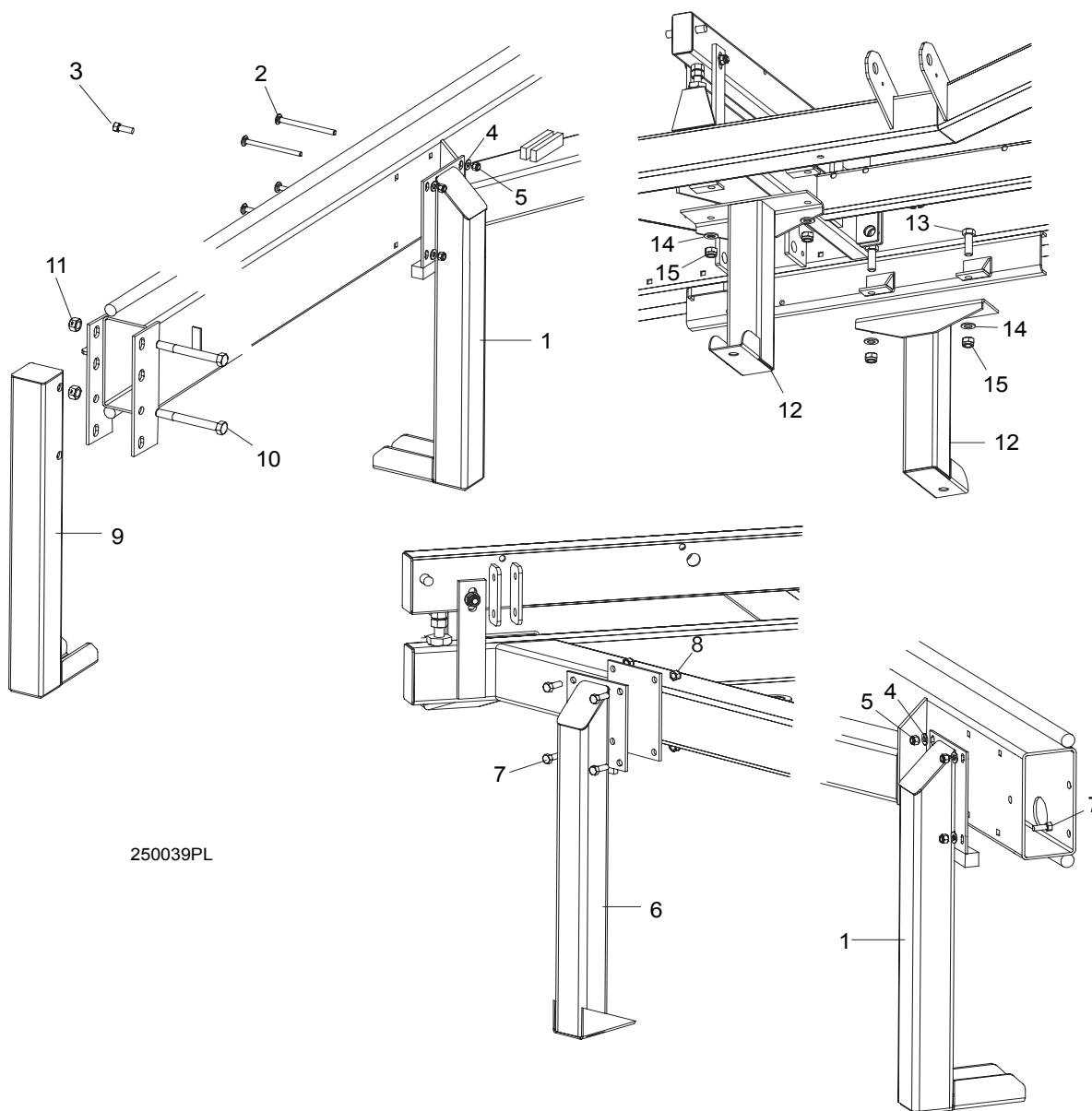

250039PL

L.P.	OPIS (♦ wskazuje części dostępne jedynie w zespołach)	NUMER KAT.	SZT.
1	PODPORA STACJONARNA DŁUGA (2 DLA LT25; 3 DLA LT25L)	087451-1	2/3
2	ŚRUBA Z Ł BEM SZEŚCIOKĄTNYM M10 X 120 - 8.8	F81003-33	8
3	ŚRUBA Z Ł BEM SZEŚCIOKĄTNYM 3/8-16 X 1" GR 2	F05007-7	4
4	PODKŁADKA PŁASKA 10,5	F81055-1	16
5	NAKRĘTKA SAMOZABEZPIEZAJĄCA Z WKŁADKĄ POLIAMIDOWĄ M10-8-B	F81033-1	8/12
6	PODPORA STACJONARNA KRÓTKA	087450-1	2
7	ŚRUBA Z Ł BEM SZEŚCIOKĄTNYM M10 X 25-8.8	F81003-11	12
8	NAKRĘTKA SAMOZABEZPIEZAJĄCA Z WKŁADKĄ POLIAMIDOWĄ M10-8-B	F81033-1	12
9	PODPORA STACJONARNA PRZEDNIA	087452-1	1
10	ŚRUBA Z Ł BEM SZEŚCIOKĄTNYM M16 X 140 - 8.8	F81006-4	2
11	NAKRĘTKA SAMOZABEZPIEZAJĄCA 5/8-11	F05010-4	2
12	PODPORA STACJONARNA ŚRODKOWA	087093-1	2

13	ŚRUBA Z Ł. BEM SZEŚCIOKĄTNYM M16 X 50-8.8	F81006-7	4	
14	PODKŁADKA PŁASKA 17	F81058-1	4	
15	NAKRĘTKA SAMOZABEZPIECZAJĄCA Z WKŁADKĄ POLIAMIDOWĄ M16	F81036-2	4	

8.10 Board Return Table, Log Side Support Assembly

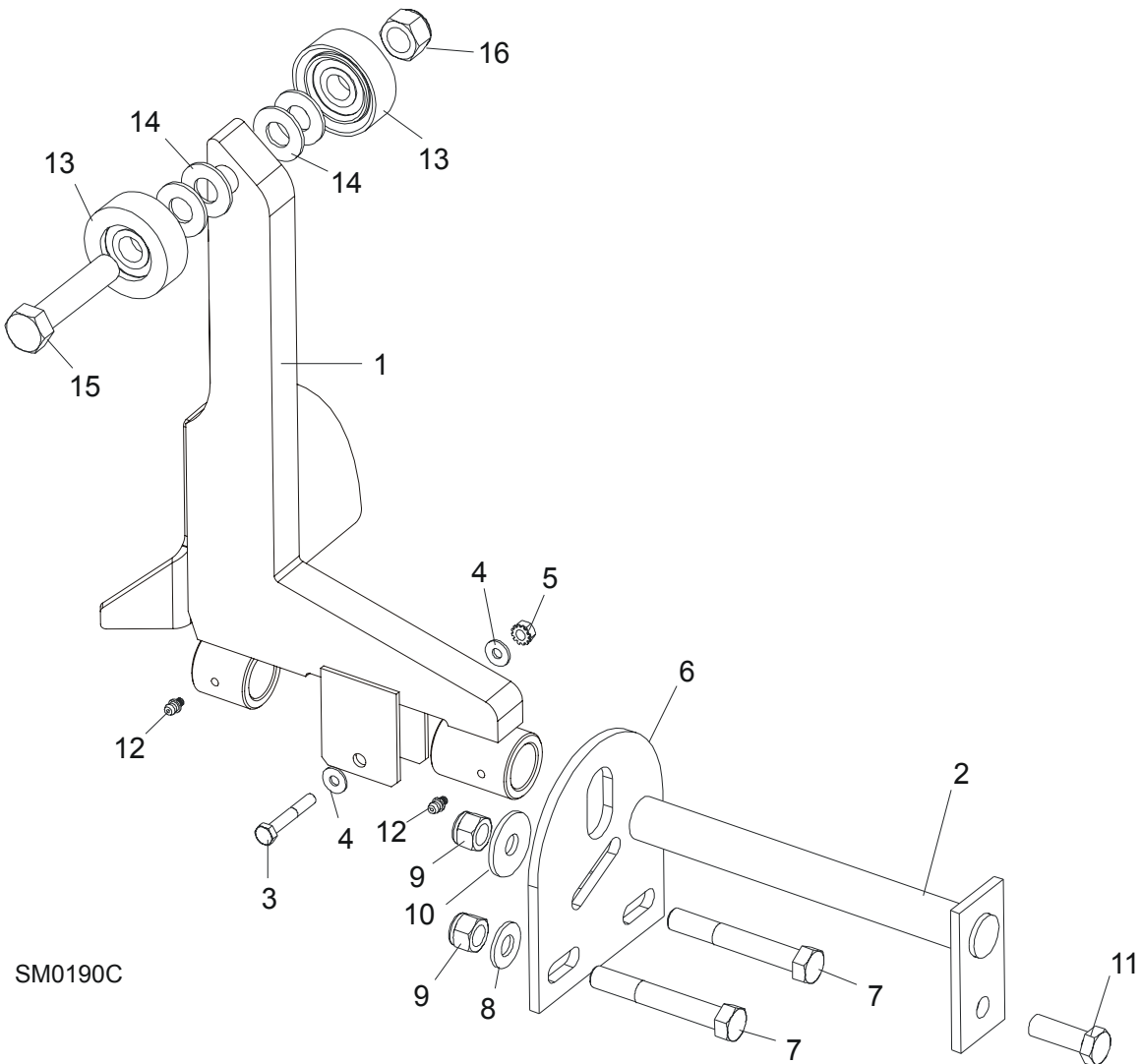

REF	DESCRIPTION (◆ Indicates Parts Available In Assemblies Only)	PART #	QTY.
1	SUPPORT, LOG SIDE W/GUARD	099785-1	1
2	PIN, LOG SIDE SUPPORT PIVOT	091549-1	1
3	BOLT, M8X45 - 8.8 HEX HEAD GRADE 5	F81002-14	1
4	WASHER, 8.4 FLAT	F81054-1	2
5	NUT, M8-8-B SELF LOCKING	F81032-2	1
6	PLATE, LOG SIDE SUPPORT END	091591-1	1
7	BOLT, M12 X 75-8.8 HEX HEAD	F81004-21	2
8	WASHER, 13 FLAT	F81056-1	2
9	NUT, M12-8 HEX NYLON LOCK	F81034-2	3
10	WASHER, 15 FLAT SPECIAL ZINC-PLATED	F81057-3	1
11	BOLT, M12 X 35-8.8 HEX HEAD	F81004-24	1
12	FITTING, 3/16" GREASE	P04107	2
13	ROLLER ASSEMBLY, SIDE SUPPORT	015014-1	2
14	WASHER, 17 FLAT	F81058-1	2
15	BOLT, M16X65-8.8-B HEX HEAD GRADE 5	F81006-1	1

16	NUT, M16-8 NYLON LOCK	F81036-2	1	
	INSTRUCTION SHEET, SIDE SUPPORT ROLLER	015109-526	1	

8.11 Tie Down Chain Assembly

SM0129

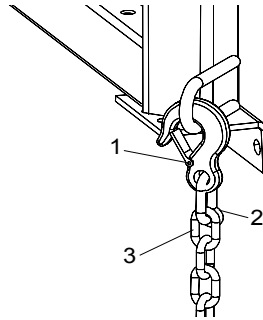

REF	DESCRIPTION (◆ Indicates Parts Available In Assemblies Only)	PART #	QTY.	
TIE DOWN CHAIN ASSEMBLY		A04376-1	1	
1	Hook, 5/8" Safety Chain	P12075	1	◆
2	Screw Closed Chain Link, 10	100767	1	◆
3	Chain, N-10 x 35, 6 Links	100951	1	◆

8.12 Bed Frame Decals

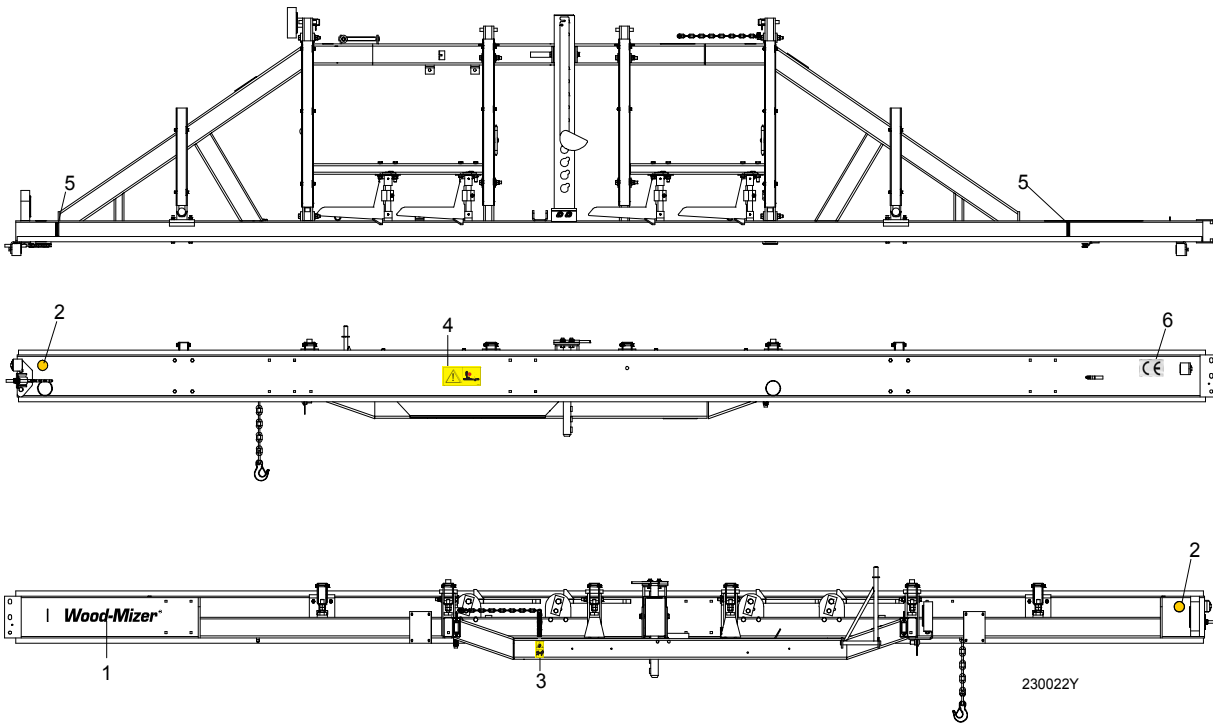

REF	DESCRIPTION (◆ Indicates Parts Available In Assemblies Only)	PART #	QTY.	
1	DECAL, WOOD-MIZER LOGO	014751	1	
2	DECAL, AMBER REFLECTIVE 2" ROUND	P07453	2	
3	DECAL, KEEP AWAY DANGER, PICTOGRAM	099221	1	
4	DECAL, SAWMILL TRAILER CAUTION, PICTOGRAM	099542	1	
5	DECAL, LOG LENGTH LIMIT	S12051	2	
6	DECAL, CE CERTIFIED SAWMILL SMALL	P85070	1	

SECTION 9 LOG CLAMP, TURNER, LOADER & TOE BOARDS

9.1 Manual Log Clamp

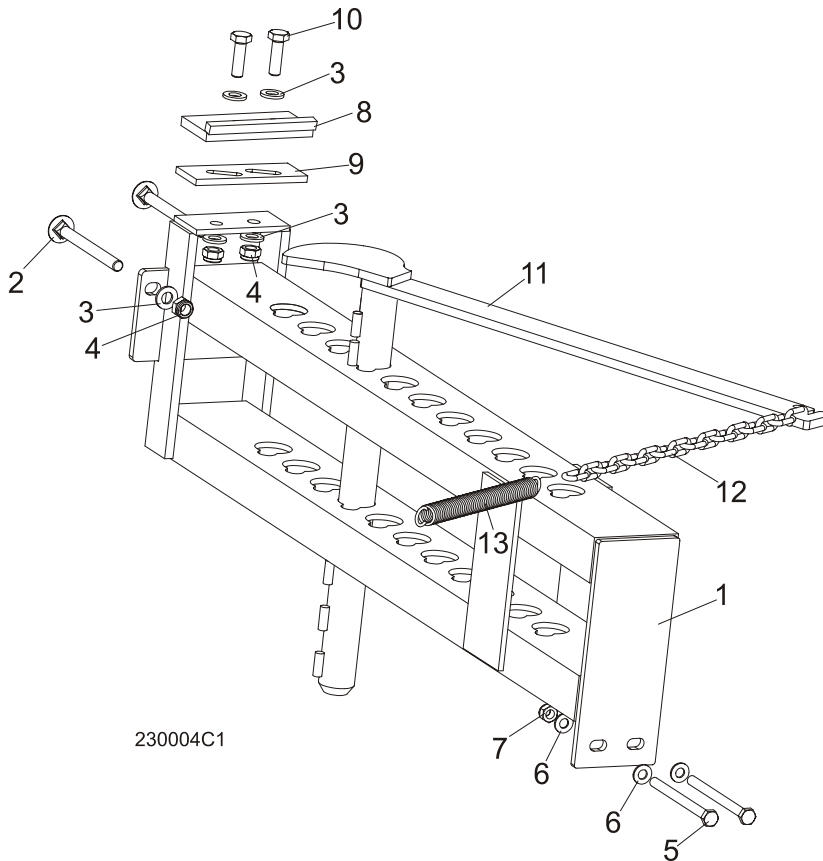

230004C1

REF	DESCRIPTION (◆ Indicates Parts Available In Assemblies Only)	PART #	QTY.
	MANUAL LOG CLAMP	092683	1
1	Bracket, Manual Log Clamp	092677-1	1
2	Bolt, M12x130-8.8 Carriage Head Zinc	F81004-26	2
3	Washer, 13 Flat Zinc	F81056-1	6
4	Nut, M12-8 Hex Nylon Zinc Lock	F81034-2	4
5	Bolt, M10x125-8.8 Hex Head Zinc	F81003-18	2
6	Washer, 10.5 Flat Zinc	F81055-1	4
7	Nut, M10-8-B Hex Nylon Zinc Lock	F81033-1	2
8	Stop Weldment, Log Clamp Painted	086980-1	1
9	Plate, Log Clamp Stop	086981	1
10	Bolt, M12 x 40-8.8 Hex Head Full Thread Zinc	F81004-4	2
11	Log Clamp Weldment, Manual Painted	100725-1	1
12	Chain, Log Clamp	M04311	1
13	Spring, FI 2.8 X FI 22.2 X 183	091864	1

9.2 Log Clamp Assembly

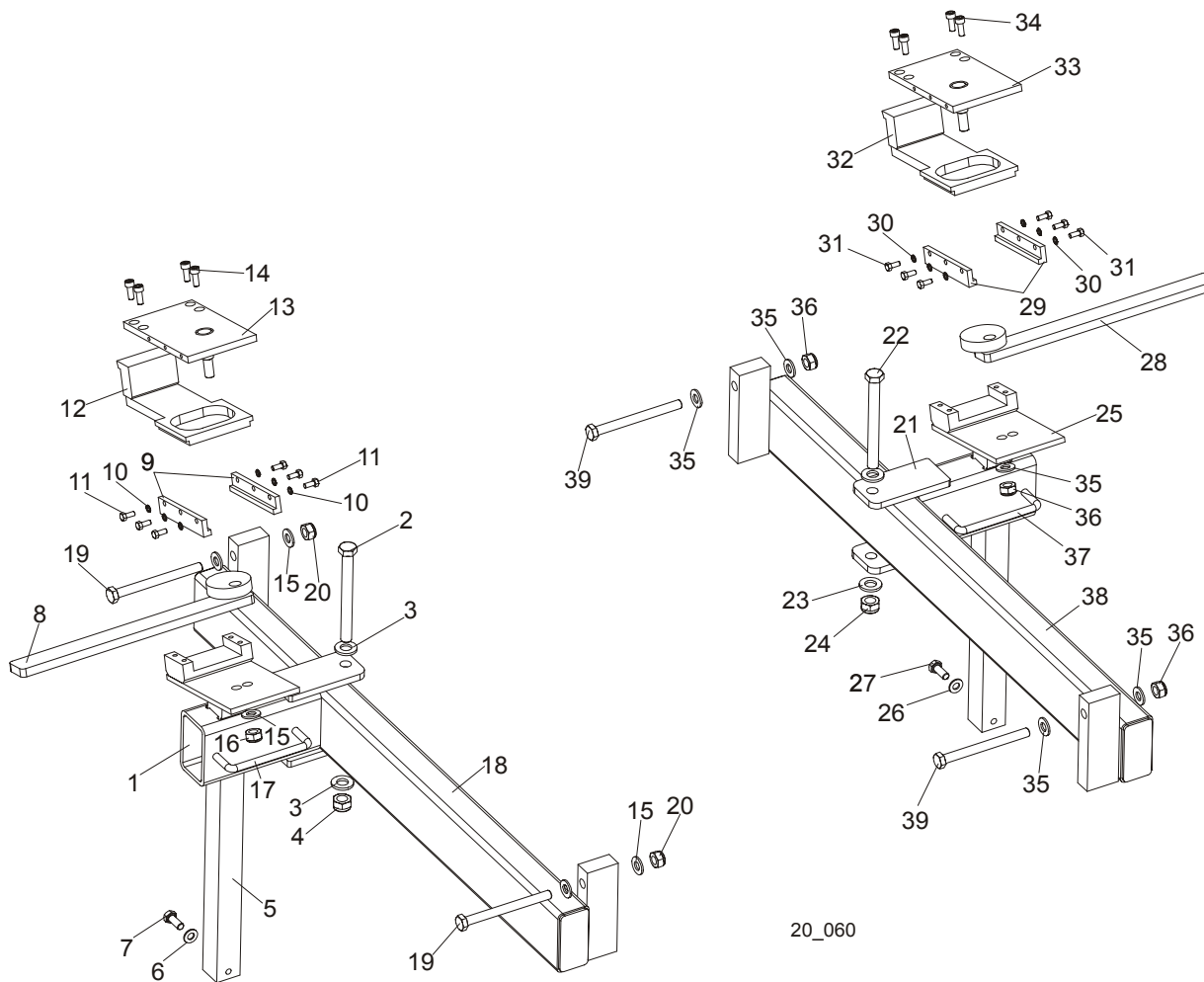

REF	DESCRIPTION (◆ Indicates Parts Available In Assemblies Only)	PART #	QTY.
	LOG CLAMP ASSEMBLY, LEFT (LT50/80 NON-HYDRAULIC)	089631 ¹	1
1	Arm Weldment, Log Clamp Zinc-plated	089624-1	1
2	Bolt, M12x120 8.8 Hex Head Zinc	F81004-38	1
3	Washer, 13 Zinc Flat	F81056-1	2
4	Nut, M12-8 Hex Nylon Zinc Lock	F81034-2	1
5	Mount Weldment, Log Clamp Zinc-plated	090174-1	1
6	Washer, 8.4 Zinc Flat	F81054-1	4
7	Bolt, M8x20-8.8-B Hex Head Full Thread Zinc	F81002-4	2
8	Lever, Log Clamp Zinc-plated	089611-1	1
9	Plate, Log Clamp Side Zinc-plated	089615-1	2
10	Washer, 5.1 Split Lock Zinc	F81052-2	6
11	Bolt, M5x12-5.8 Hex Head Full Thread Zinc	F81000-5	6
12	Plate, Clamping Zinc-plated	090202-1	1
13	Plate, Log Clamp Upper Zinc-plated	089614-1	1
14	Screw, M6x16-8.8 Hex Socket Set Cap Zinc	F81001-21	4
15	Washer, 10.5 Zinc Flat	F81055-1	5
16	Nut, M8-8-B Hex Nylon Zinc Lock	F81032-2	1
17	Handle, 4" w/Bolts	P08065	1

18	Bar Weldment, Log Clamp Guide Ptd	089628-1	1	
19	Bolt, M10x110 8.8 Hex Head Zinc	F81003-43	2	
20	Nut, M10-8-B Hex Nylon Zinc Lock	F81033-1	2	
	LOG CLAMP ASSEMBLY, RIGHT (NON-HYDRAULIC)	090349	1	
21	Arm Weldment, Log Clamp Zinc-plated	089624-1	1	
22	Bolt, M12x120 8.8 Hex Head Zinc	F81004-38	1	
23	Washer, 13 Zinc Flat	F81056-1	2	
24	Nut, M12-8 Hex Nylon Zinc Lock	F81034-2	1	
25	Mount Weldment, Log Clamp Zinc-plated	090174-1	1	
26	Washer, 8.4 Zinc Flat	F81054-1	2	
27	Bolt, M8x20-8.8-B Hex Head Full Thread Zinc	F81002-4	2	
28	Lever, Log Clamp Zinc-plated	090348-1	1	
29	Plate, Log Clamp Side Zinc-plated	089615-1	2	
30	Washer, 5.1 Split Lock Zinc	F81052-2	6	
31	Bolt, M5x12-5.8 Hex Head Full Thread Zinc	F81000-5	6	
32	Plate, Clamping Zinc-plated	090202-1	1	
33	Plate, Log Clamp Upper Zinc-plated	090347-1	1	
34	Screw, M6x16-8.8 Hex Socket Head Cap Zinc	F81001-21	4	
35	Washer, 10.5 Zinc Flat	F81055-1	5	
36	Nut, M10-8-B Hex Nylon Zinc Lock	F81033-1	3	
37	Handle, 4" w/Bolts	P08065	1	
38	Bar Weldment, Log Clamp Guide Ptd	089628-1	1	
39	Bolt, M10x110 8.8 Hex Head Zinc	F81003-43	2	

¹ The number of clamps depends on the frame length.

9.3 Manual Log Turner

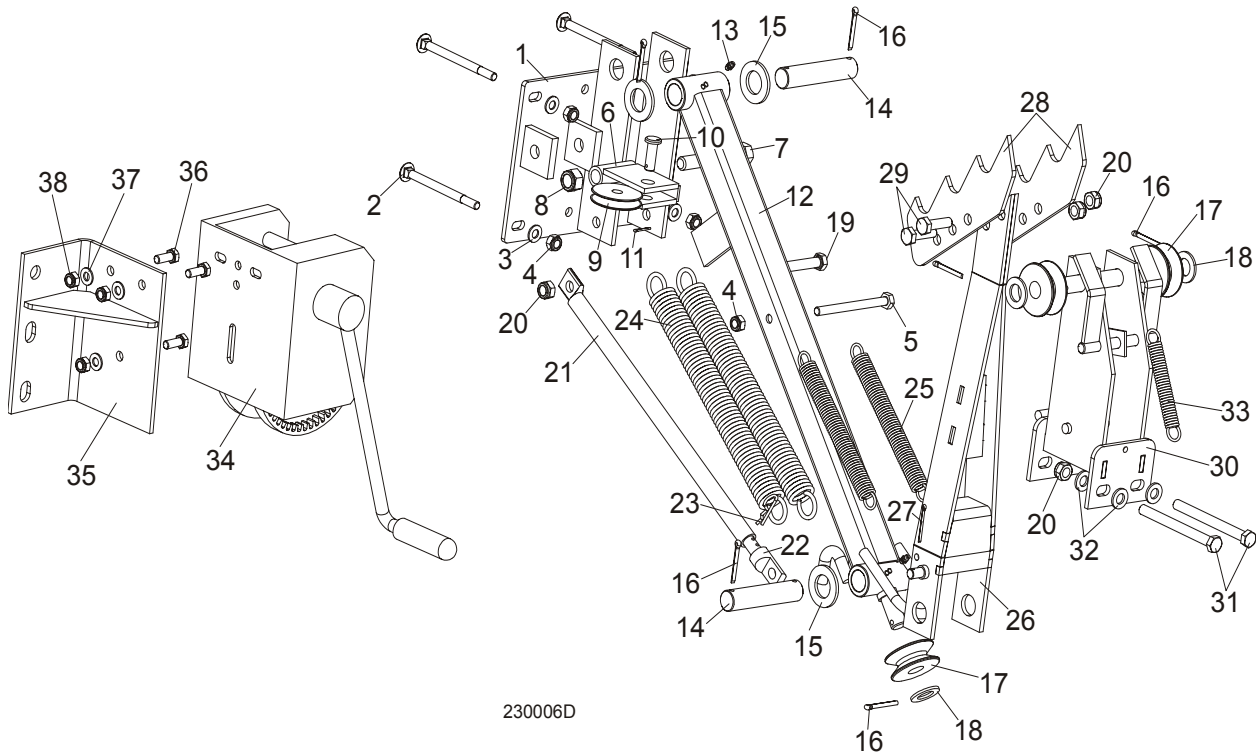

REF	DESCRIPTION (◆ Indicates Parts Available In Assemblies Only)	PART #	QTY.
	MANUAL LOG TURNER OPTION (S/M TYPE FRAME)	091291	1
	MANUAL LOG TURNER OPTION (L TYPE FRAME)	091562	1
1	Bracket Weldment, Manual Log Turner Painted (S/M Type Frame)	091269-1	1
	Bracket Weldment, Manual Log Turner Painted (L Type Frame)	090271-1	1
2	Bolt, M10x120 8.8 Carriage Head Zinc	F81003-33	4
3	Washer, 10.5 Flat Zinc	F81055-1	4
4	Nut, M10-8-B Hex Nylon Zinc Lock	F81033-1	5
5	Bolt, M10x115-8.8 Hex Head Zinc	F81003-19	1
6	Bracket Weldment, Cable Guide Pulley Painted	091295-1	1
7	Bolt, M16x100-8.8 Hex Head Full Thread Zinc	F81006-2	1
8	Nut, M16-8 Hex Nylon Zinc Lock	F81036-2	1
9	Pulley, Zinc-Plated Cable Guide	091273-1	1
10	Pin, 12x35 B Clevis Zinc	F81049-1	1
11	Pin, 2.5x20 Cotter Zinc	F81043-1	1
12	Arm Weldment, Manual Turner Lower Painted	091256-1	1
13	Fitting, M6 Grease	086280	2
14	Pin, Manual Turner Arm Pivot Zinc-Plated	091275-1	2
15	Washer, 28 Flat Zinc	F81061-1	4
16	Pin, 5x40 Cotter Zinc	F81043-31	7
17	Pulley, Manual Turner Zinc-Plated	091280-1	3
18	Washer, 20.5 Split Lock Zinc	F81059-1	5
19	Bolt, M12x120 8.8 Hex Head Zinc	F81004-38	1

20	Nut, M12-8 Hex Nylon Zinc Lock	F81034-2	5	
21	Tube, Manual Turner Painted	091537-1	1	
22	Rod Weldment, Manual Turner Painted	091540-1	1	
23	Pin, 1/8x1 13/16 Safety	P05059	1	
24	Spring, FI 4.5 x FI 35 x 303	091863	2	◆
25	Spring, FI 2.8 x FI 22.2 x183	091864	2	
26	Arm Weldment, Manual Turner Upper Painted	091263-1	1	
27	Pin, 4x25 Cotter Zinc	F81043-2	1	
28	Claw, Log Turner Painted	088082-1	2	
29	Bolt, M12x40-8.8 Hex Head Full Thread Zinc	F81004-4	2	
30	Bracket Weldment, Manual Turner Pulley Painted	091281-1	1	
31	Bolt, M12x130-8.8 Hex Head Zinc	F81004-36	2	
32	Washer, 13 Flat Zinc	F81056-1	4	
33	Spring, FI 1.9 X FI 14.2 X 104	091865	1	
34	WINCH, AL-KO TYPE 901	096453	1	
35	BRACKET, WINCH MOUNT (COMP. NON-HYD FRAME)	085841-1	1	
36	BOLT, M10-1.5X25MM HH GR8.8	F81003-11	3	
37	WASHER, FLAT, M10, ZINC	F81055-1	3	
38	NUT, M10, NYLON HEX ZINC LOCK	F81033-1	3	

9.4 Manual Toe Board

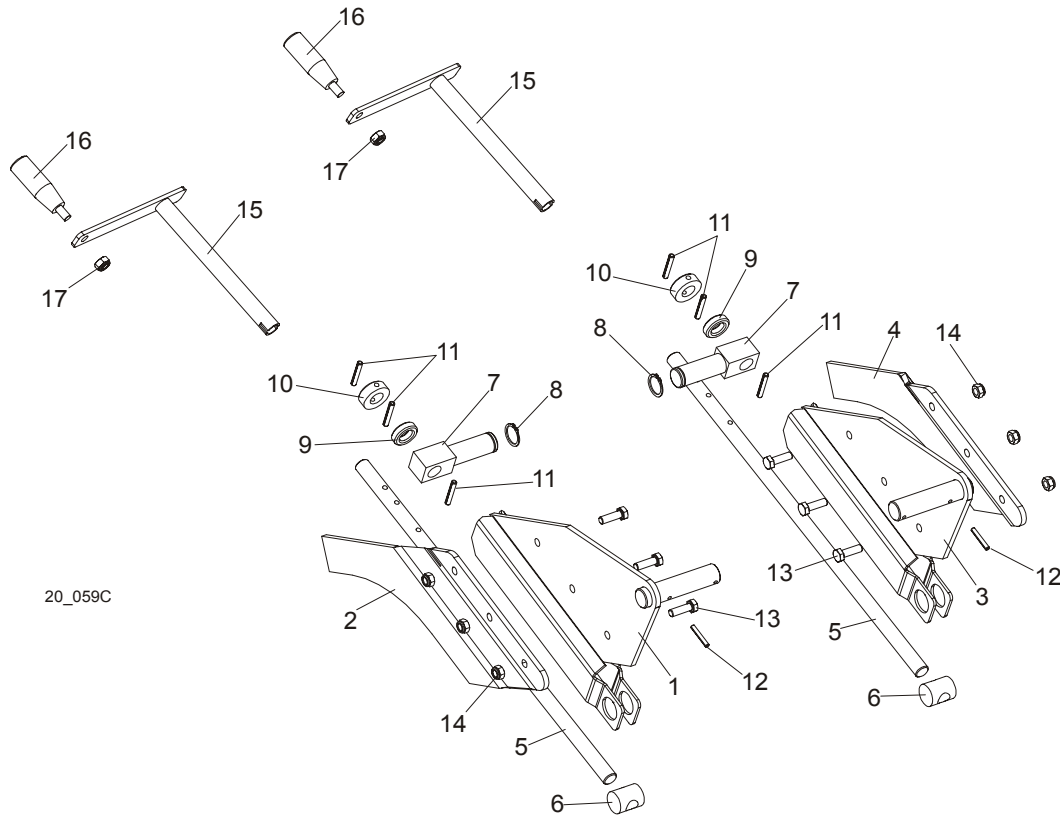

REF	DESCRIPTION (◆ Indicates Parts Available In Assemblies Only)	PART #	QTY.
	TOE BOARD KIT, MANUAL FRONT	094929	1
1	Plate Weldment, Manual Toe Board Front	094927-1	1
2	Extension, Manual Toe Board Plate (I)	095203-1	1
	TOE BOARD KIT, MANUAL REAR	094928	1
3	Plate Weldment, Manual Toe Board Rear	094926-1	1
4	Extension, Manual Toe Board Plate (II)	095202-1	1
5	Shaft, Manual Toe Board	090344-1	2
6	Nut, Special Threaded	090017	2
7	Pivot, Manual Toe Board Shaft (I)	094931-1	2
8	Ring, Z 22 Outside Retaining	F81090-24	2
9	Bearing, 5/8" Thrust	P04214	2
10	Collar, 16	F81039-6	2
11	Pin, 5x35-N-C PN-EN ISO 8752 Roll	F81044-9	6
12	Pin, 4x30 Zinc Roll	F81044-7	2
13	Bolt, M8 x 25-8.8-B Hex Head Full Thread Zinc	F81002-5	6
14	Nut, M8-8-B Hex Nylon Zinc Lock	F81032-2	6
	CRANK ASSEMBLY, MANUAL TOE BOARD	500600	2
15	Crank, Manual Toe Board	500599-1	1
16	Knob, Plastic Crank Handle	086338	1
17	Nut, M10-8-B Nylon Hex Zinc Lock	F81033-1	1

9.5 Manual Log Loader (S/M Type Frame)

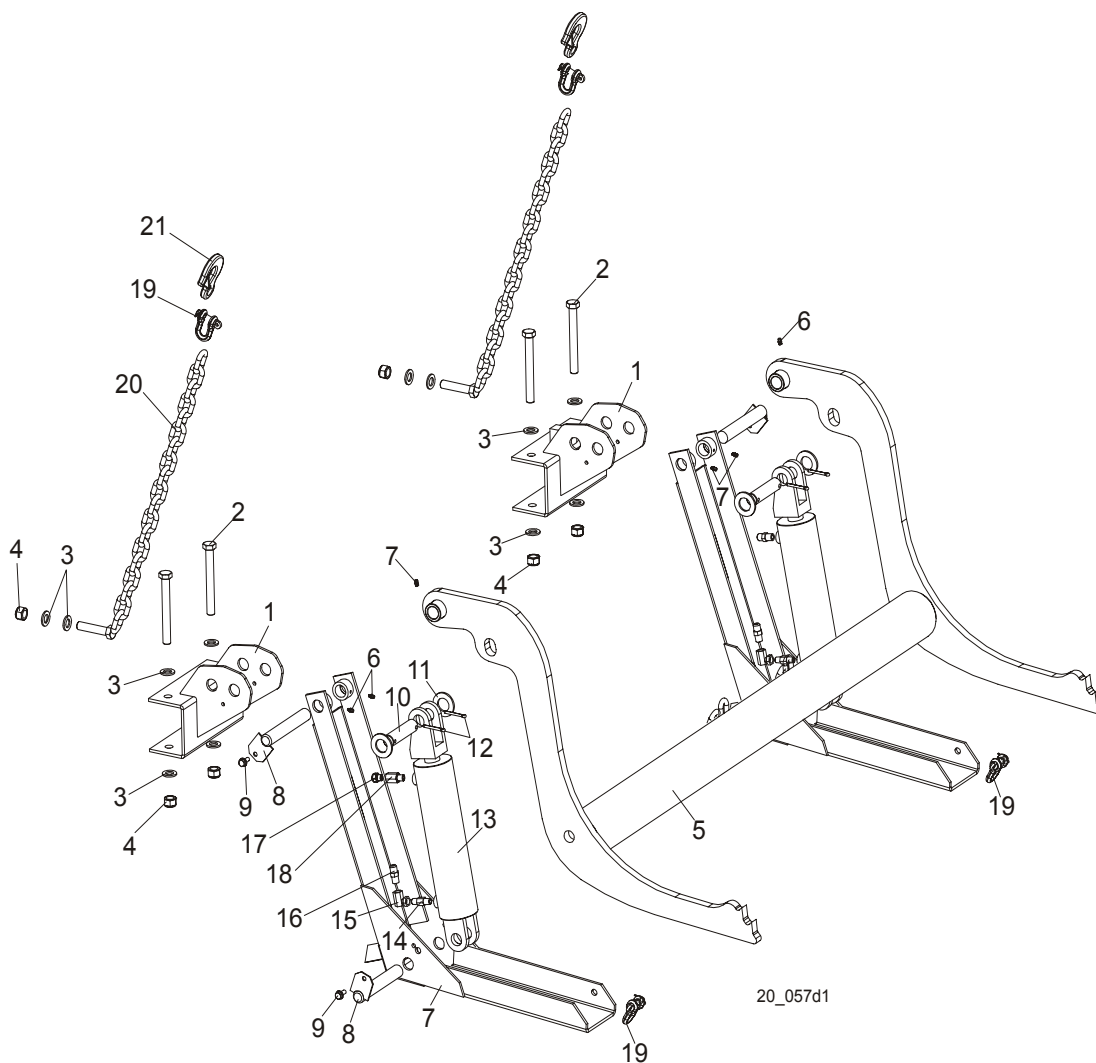

REF	DESCRIPTION (◆ Indicates Parts Available In Assemblies Only)	PART #	QTY.
	LOG LOADER, LT20 COMPLETE	091952	1
1	Bracket , Log Loader Mount Painted (S/M Type Frame)	092865-1	2
2	Bolt, M16x140-8.8 Hex Head Zinc	F81006-4	4
3	Washer, 17 Zinc Flat	F81058-1	12
4	Nut, M16-8 Hex Nylon Zinc Lock	F81036-2	6
	Log Loader W/Chain, LT20	091954	1
5	Loader Weldment, Log Painted	090006-1	1
6	Fitting, 3/16" Straight Grease	P04107	6
7	Foot, Log Loader Painted	090048-1	2
8	Pin Weldment, Log Loader Painted	W09446-1	4
9	Screw, 5/16-18 x 3/4 Self-Tapping	F05015-30	4
10	Pin, Hydraulic Cylinder Zinc-Plated	086979-1	2
11	Washer, 28 Zinc Flat	F81061-1	4
12	Pin, 5x40 Cotter	F81043-31	4
	Cylinder Assembly, LT20 Log Loader	094333	2
13	Cylinder, CJ-S95-16-70/32/203 Hydraulic	088680	1

14	Fitting, 1/4 NPT 4.0 GPM Velocity Fuse	015750	1	
15	Fitting, #9455X4X4 90 Deg. Swivel Elbow	P12199	1	
16	Fitting, 3/8JIC-1/4 NPT Straight	015560	1	
17	Air Vent Valve 2901-14-17	090794	1	
18	Fitting, $\frac{1}{4}$ " F. Thread/ $\frac{1}{4}$ " NPT M. Thread Reducer	090795	1	
19	Shackle, M-WL. .63	099525	4	
20	Chain, LT20 Log Loader Painted	099218-1	2	
21	Hook, 5/8 Safety Chain	P12075	2	

9.6 Manual Log Loader (L Type Frame)

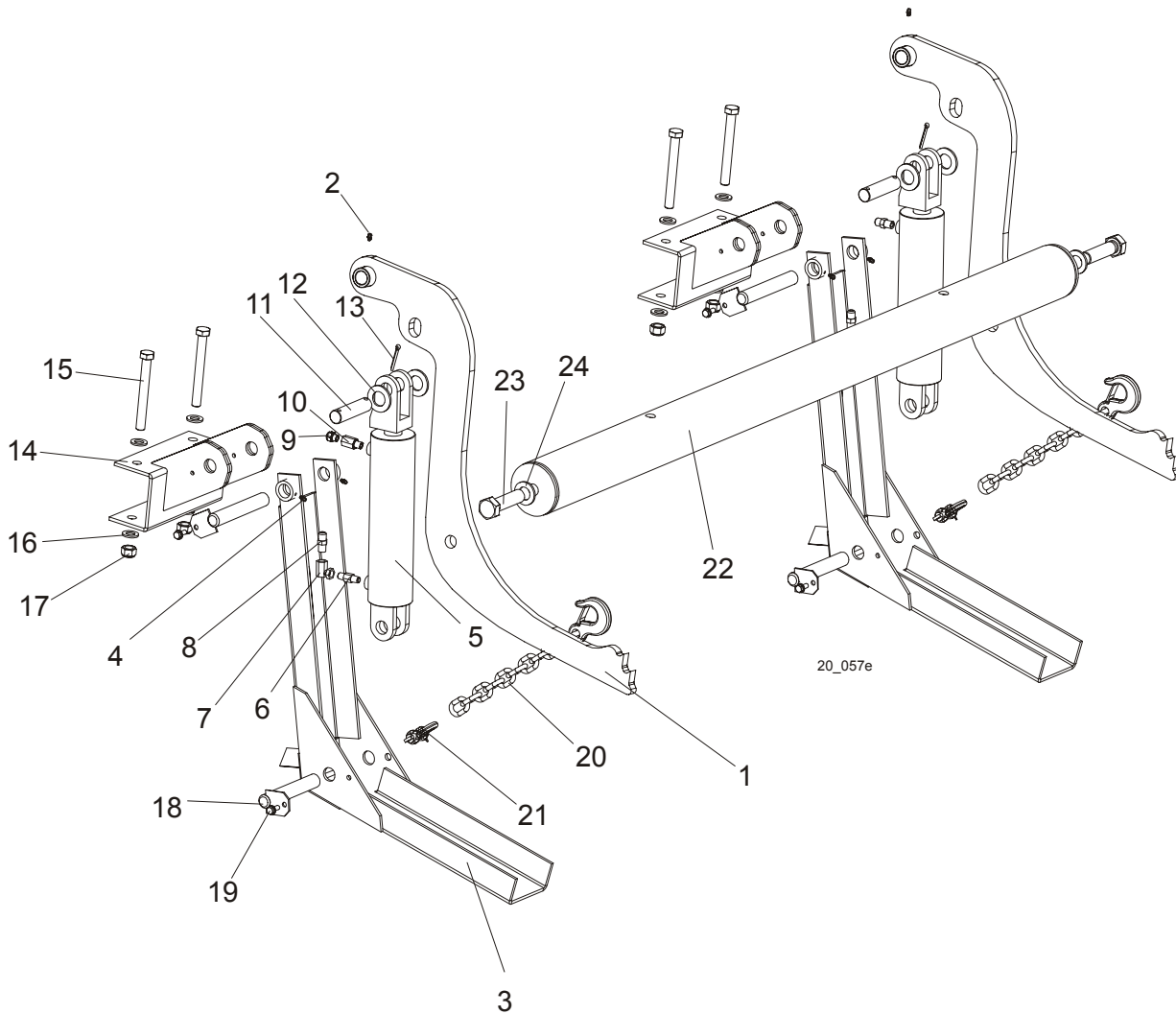

REF	DESCRIPTION (◆ Indicates Parts Available In Assemblies Only)	PART #	QTY.
	LOG LOADER, SINGLE ARM, MH SAWMILLS	095390	2
	Arm, Log Loader Single (9.5 m Frame)	090051	1
1	Arm Weldment, Log Loader Painted	089657-1	1
2	Fitting, 3/16" Straight Grease	P04107	1
	Foot Assembly, Log Loader	090049	1
3	Foot, Log Loader Painted	090048-1	1
4	Fitting, 3/16" Straight Grease	P04107	2
	Cylinder Assembly, LT20 Log Loader	094333	1
5	Cylinder, CJ-S95-16-70/32/203 Hydraulic	088680	1
6	Fitting, 1/4 NPT 4.0 GPM Velocity Fuse	015750	1
7	Fitting, #9455X4X4 90 deg. Swivel Elbow	P12199	1
8	Fitting, 3/8JIC-1/4 NPT Straight	015560	1
9	Air Vent Valve 2901-14-17	090794	1
10	Fitting, 1/4" F. Thread/ 1/4" NPT M. Thread Reducer	090795	1
11	Pin, Hydraulic Cylinder Zinc-Plated	086979-1	1
12	Washer, 28 Flat Zinc	F81061-1	2

13	Pin, 5x40 Cotter	F81043-31	2	
14	Bracket Weldment, Log Loader Mount Painted	089841-1	1	
15	Bolt, M16x140-8.8 Hex Head Zinc	F81006-4	2	
16	Washer, 17 Flat Zinc	F81058-1	4	
17	Nut, M16-8 Hex Nylon Zinc Lock	F81036-2	2	
18	Pin Weldment, Log Loader Painted	W09446-1	2	
19	Screw, 5/16-18 x 3/4 Self-Tapping	F05015-30	2	
20	Chain, Log Loader Safety	090090-1	1	
21	Shackle, M-WL. .63	086540	1	
22	Link, Log Loader Arms	090315	1	
23	Bolt, M24x2x90-8.8 Hex Head Full Thread Zinc	F81009-2	2	
24	Washer, 25 Flat Zinc	F81061-3	2	

9.7 Manual Log Loader Pump

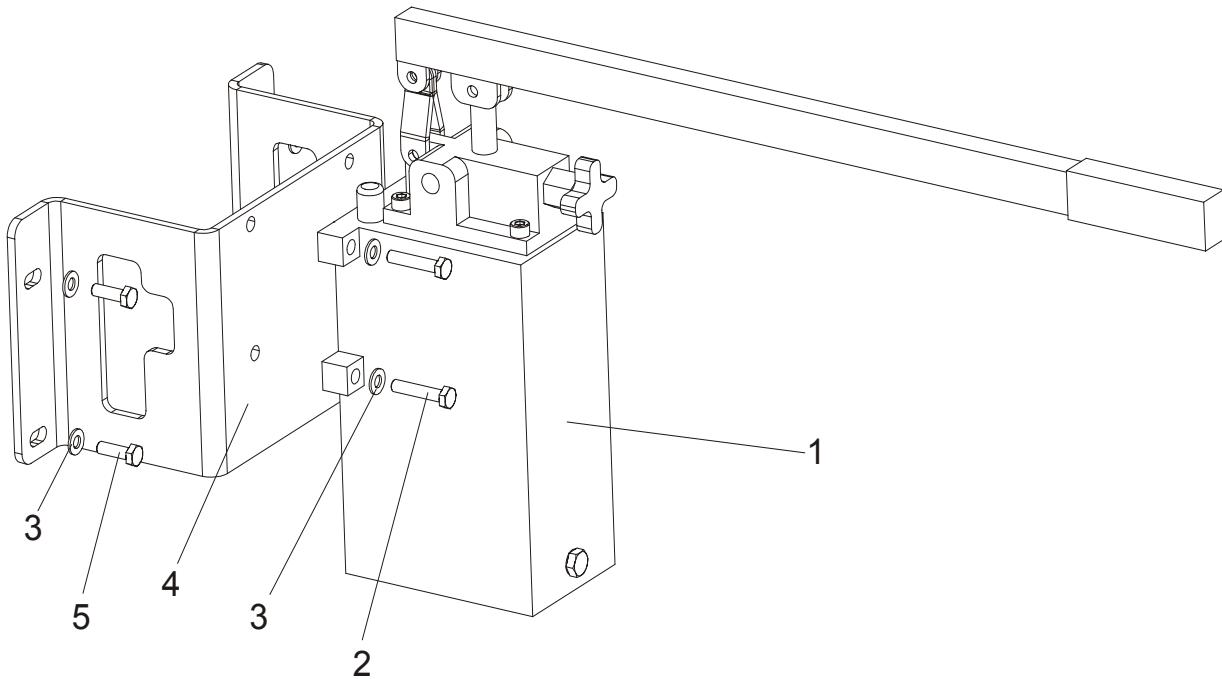

REF	DESCRIPTION (◆ Indicates Parts Available In Assemblies Only)	PART #	QTY.	
1	PUMP, PAM 014 2500 3L MANUAL	090309	1	
2	BOLT, M8X80-8.8 HEX HEAD ZINC	F81002-18	4	
3	WASHER, 8.4 ZINC FLAT	F81054-1	8	
4	BRACKET, LOG LOADER PUMP MOUNT	090377-1	1	
5	BOLT, M8X25-8.8-B HEX HEAD FULL THREAD ZINC	F81002-5	4	