

# Wood-Mizer<sup>®</sup> Sawmill

## Parts Manual

---

LT20 Series AC MH  
LT20 Series DC MH

rev. B2.03  
rev. B2.03

---



**Safety is our #1 concern!** Read and understand all safety information and instructions before operating, setting up or maintaining this machine.

*April 2003*

*Form #615*

# Table of Contents

# Section-Page

<b>SECTION 1</b>	<b>GENERAL INFORMATION</b>	<b>1-1</b>
1.1	How To Use The Parts List .....	1-1
1.2	Sample Assembly .....	1-1
<b>SECTION 2</b>	<b>BLADE GUIDE ROLLERS &amp; ARM</b>	<b>2-1</b>
2.1	Blade Guide Assembly, Idle Side.....	2-1
2.2	Blade Guide Assembly, Drive Side.....	2-3
2.3	Blade Guide Arm Assembly.....	2-5
<b>SECTION 3</b>	<b>BLADE WHEELS &amp; TENSIONER</b>	<b>3-1</b>
3.1	Blade Wheel Assembly, Drive Side .....	3-1
3.2	Blade Wheel Assembly, Idle Side.....	3-3
3.3	Blade Tensioner Assembly.....	3-5
<b>SECTION 4</b>	<b>SAW HEAD</b>	<b>4-1</b>
4.1	Middle Throat Screw .....	4-1
4.2	Drive Belt Tensioner, DC Sawmills.....	4-2
4.3	Water Lube Assembly .....	4-4
4.4	Saw Head Decals.....	4-6
4.5	Blade Housing Cover .....	4-8
4.6	Control Box (AC Sawmills) .....	4-10
4.7	Control Box (DC Sawmills).....	4-12
4.8	Drum Switches .....	4-14
4.9	Sawdust Chute.....	4-15
<b>SECTION 5</b>	<b>UP/DOWN ASSEMBLY</b>	<b>5-1</b>
5.1	Up/Down Assembly, AC Mills .....	5-1
5.2	Up/Down Assembly, DC Mills .....	5-3
5.3	Manual Up/Down System .....	5-5
5.4	Up/Down Chain Tensioner Assembly.....	5-7
5.5	Battery Box Assembly, DC Mills.....	5-8
<b>SECTION 6</b>	<b>UP/DOWN ROLLERS &amp; BLADE HEIGHT SCALE</b>	<b>6-1</b>
6.1	Up/Down Rollers.....	6-1
6.2	Blade Height Scale .....	6-3
<b>SECTION 7</b>	<b>POWER FEED &amp; TRACK ROLLERS</b>	<b>7-1</b>
7.1	Power Feed Assembly, AC Mills .....	7-1
7.2	Power Feed Assembly, DC Mills .....	7-3
7.3	Upper Track Rollers And Wipers .....	7-5
7.4	Lower Track Rollers .....	7-7

# Table of Contents

# Section-Page

## **SECTION 8 BED FRAME ASSEMBLY**

**8-1**

8.1	Bed Rail Assembly, Front And Rear (S/M type frame).....	8-1
8.2	Bed Rail Assembly, Front Middle (S/M type frame).....	8-2
8.3	Bed Rail Assembly, Rear Middle (S/M type frame).....	8-3
8.4	Bed Rail Assembly (L type frame).....	8-4
8.5	Bed Rail Assembly (L type frame).....	8-5
8.6	Stationary Leg .....	8-7
8.7	Pivot Bed Rail Assembly.....	8-9
8.8	Log Side Support Assembly .....	8-11
8.9	Tie Down Chain Assembly .....	8-13
8.10	Bed Frame Decals.....	8-14

## **SECTION 9 LOG CLAMP, TURNER, LOADER & TOE BOARDS**

**9-1**

9.1	Manual Log Clamp .....	9-1
9.2	Log Clamp Assembly.....	9-2
9.3	Manual Log Turner.....	9-4
9.4	Manual Toe Board.....	9-6
9.5	Manual Log Loader ( S/M type frame ) .....	9-8
9.6	Manual Log Loader ( L type frame ).....	9-10
9.7	Manual Log Loader Pump.....	9-12

## SECTION 1 GENERAL INFORMATION

### 1.1 How To Use The Parts List

- Use the index above to locate the assembly that contains the part you need.
- Go to the appropriate section and locate the part in the illustration.
- Use the number pointing to the part to locate the correct part number and description in the table.
- Parts shown indented under another part are included with that part.
- Parts marked with a diamond (◆) are only available in the assembly listed above the part.

See the sample table below. Sample Part #A01111 includes part F02222-2 and subassembly A03333. Subassembly A03333 includes part S04444-4 and subassembly K05555. The diamond (◆) indicates that S04444-4 is not available except in subassembly A03333. Subassembly K05555 includes parts M06666 and F07777-77. The diamond (◆) indicates M06666 is not available except in subassembly K05555.

<b>1.2 Sample Assembly</b>				
REF	DESCRIPTION (◆ Indicates Parts Available In Assemblies Only)	PART #	QTY.	
	Sample Assembly, Complete (Includes All Indented Parts Below)	A01111	1	
1	Sample Part	F02222-22	1	
	Sample Subassembly (Includes All Indented Parts Below)	A03333	1	
2	Sample Part (◆ Indicates Part Is Only Available With A03333)	S04444-4	1	◆
	Sample Subassembly (Includes All Indented Parts Below)	K05555	1	
3	Sample Part (◆ Indicates Part Is Only Available With K05555)	M06666	2	◆
4	Sample Part	F07777-77	1	

#### **To Order Parts:**

- From Europe call our European Headquarters and Manufacturing Facility in Kolo, Poland at **+48-63-2626000**. From the continental U.S., call our toll-free Parts hotline at **1-800-448-7881**. Have your customer number, vehicle identification number, and part numbers ready when you call.
- From other international locations, contact the Wood-Mizer distributor in your area for parts.

## SECTION 2 BLADE GUIDE ROLLERS & ARM

### 2.1 Blade Guide Assembly, Idle Side

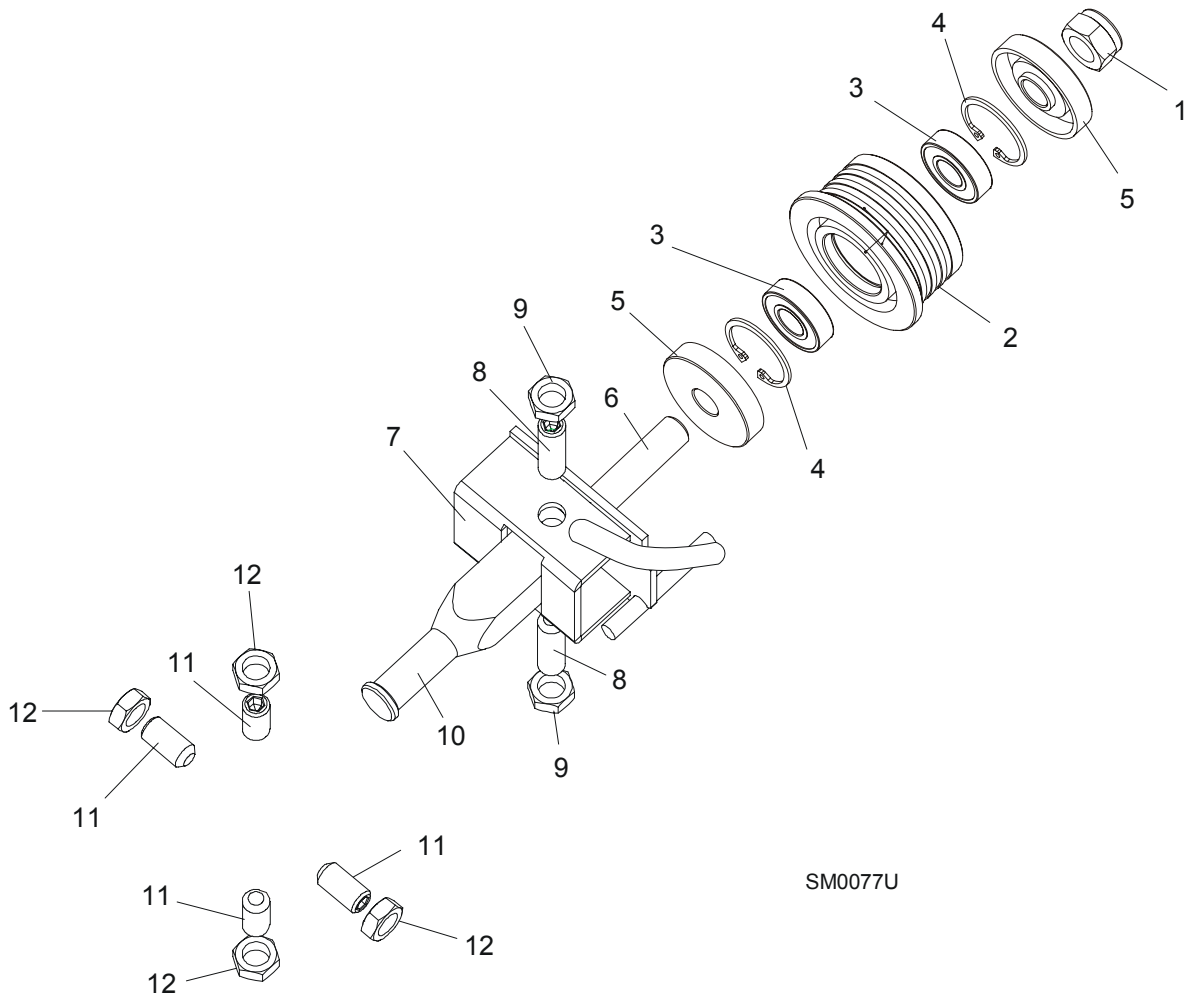

SM0077U

REF	DESCRIPTION (◆ Indicates Parts Available In Assemblies Only)	PART #	QTY.	
	<b>BLADE GUIDE ASSEMBLY, IDLE SIDE</b>	094683	1	
	Roller, Blade Guide Complete Standard	087887	1	
1	Nut, M12-8 Hex Nylon Zinc Lock	F81034-2	1	
2	Roller, Blade Guide Narrow	087889	1	◆
3	Bearing, 6001 2RSR FAG	087893	2	
4	Ring, W28 Inside Retaining	F81090-9	1	
5	Washer, Zinc-plated Spacer	087891-1	2	
6	Shaft, Blade Guide Roller Zinc-plated	087763-1	1	
7	Bracket Weldment, Idle Side Blade Guide Painted	094681-1	1	
8	Screw, M10x1x40 DIN 913 A2-70 Set Stainless Steel	F81015-2	2	

**2****Blade Guide Rollers & Arm***Blade Guide Assembly, Idle Side*

---

9	Nut, M10x1-04-ST-A2 ISO 8675 Thin	F81033-10	2	
10	Shaft, Blade Guide Mount Zinc-plated	088255-1	1	
11	<b>SCREW, M10X1X20 DIN 913 SET STAINLESS STEEL</b>	F81015-1	4	
12	<b>NUT, M10x1-04-ST-A2 ISO 8675 THIN</b>	F81033-10	4	

## 2.2 Blade Guide Assembly, Drive Side

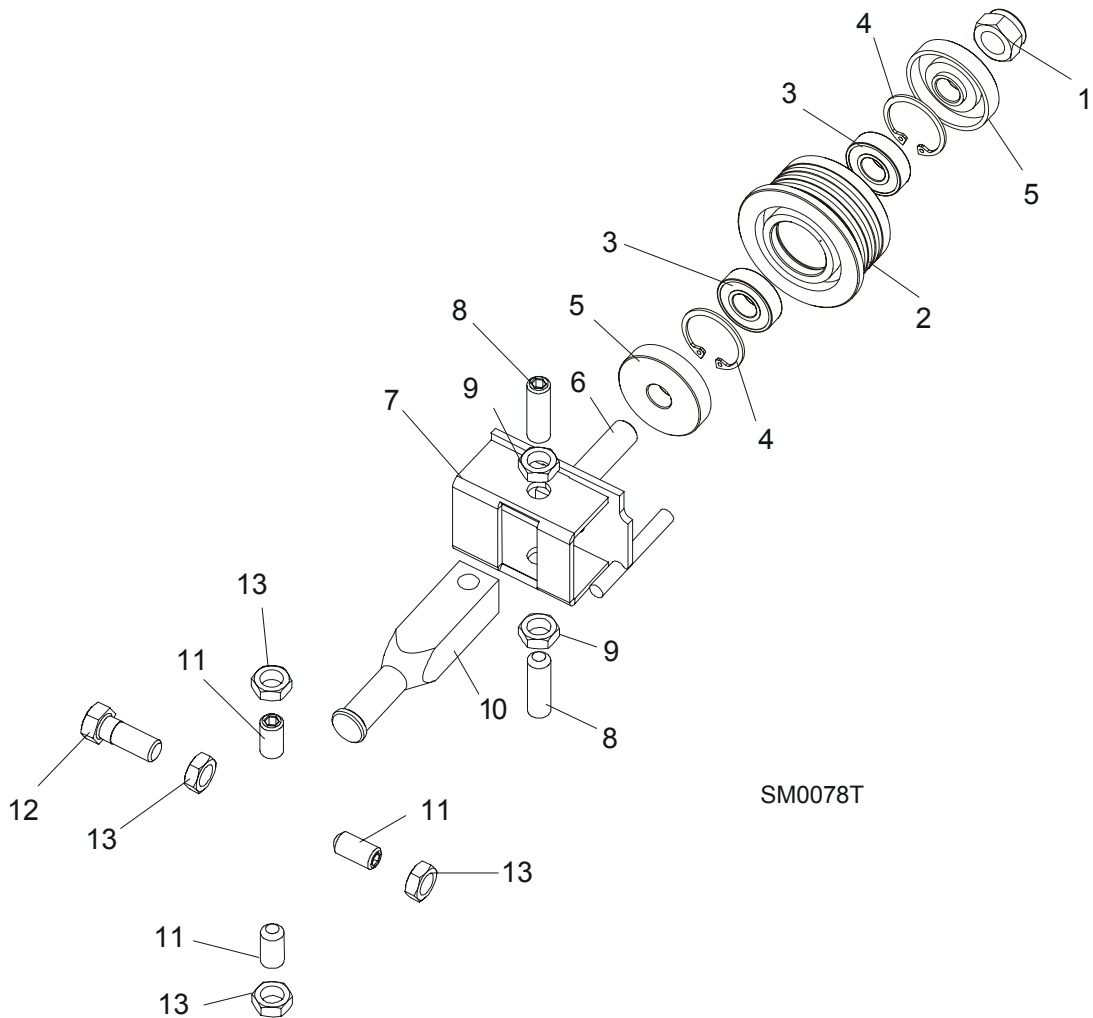

REF	DESCRIPTION (◆ Indicates Parts Available In Assemblies Only)	PART #	QTY.	
	<b>BLADE GUIDE ASSEMBLY, DRIVE SIDE</b>	094682	1	
	Roller, Blade Guide Complete Standard	087887	1	
1	Nut, M12-8 Hex Nylon Zinc Lock	F81034-2	1	
2	Roller, Blade Guide Narrow	087889	1	◆
3	Bearing, 6001 2RSR FAG	087893	2	
4	Ring, W28 Inside Retaining	F81090-9	1	
5	Washer, Zinc-plated Spacer	087891-1	2	
6	Shaft, Blade Guide Roller Zinc-plated	087763-1	1	
7	Bracket Weldment, Blade Guide Painted	094679-1	1	
	Screw Kit, Blade Guide Adjustment w/Nuts (for two blade guide assemblies)	K09942	1	
8	Screw, M10x1x40 DIN 913 A2-70 Set Stainless Steel	F81015-2	2	
9	Nut, M10x1-04-ST-A2 ISO 8675 Thin	F81033-10	2	

**2****Blade Guide Rollers & Arm***Blade Guide Assembly, Drive Side*

---

<b>10</b>	Shaft, Blade Guide Mount Zinc-plated	088255-1	1	
<b>11</b>	<b>SCREW, M10X1X20 DIN 913 SET STAINLESS STEEL</b>	F81015-1	3	
<b>12</b>	<b>BOLT, M10X1X25 DIN 933 STAINLESS STEEL</b>	F81003-28	1	
<b>13</b>	<b>NUT, M10x1-04-ST-A2 ISO 8675 THIN</b>	F81033-10	4	



## 2.3 Blade Guide Arm Assembly

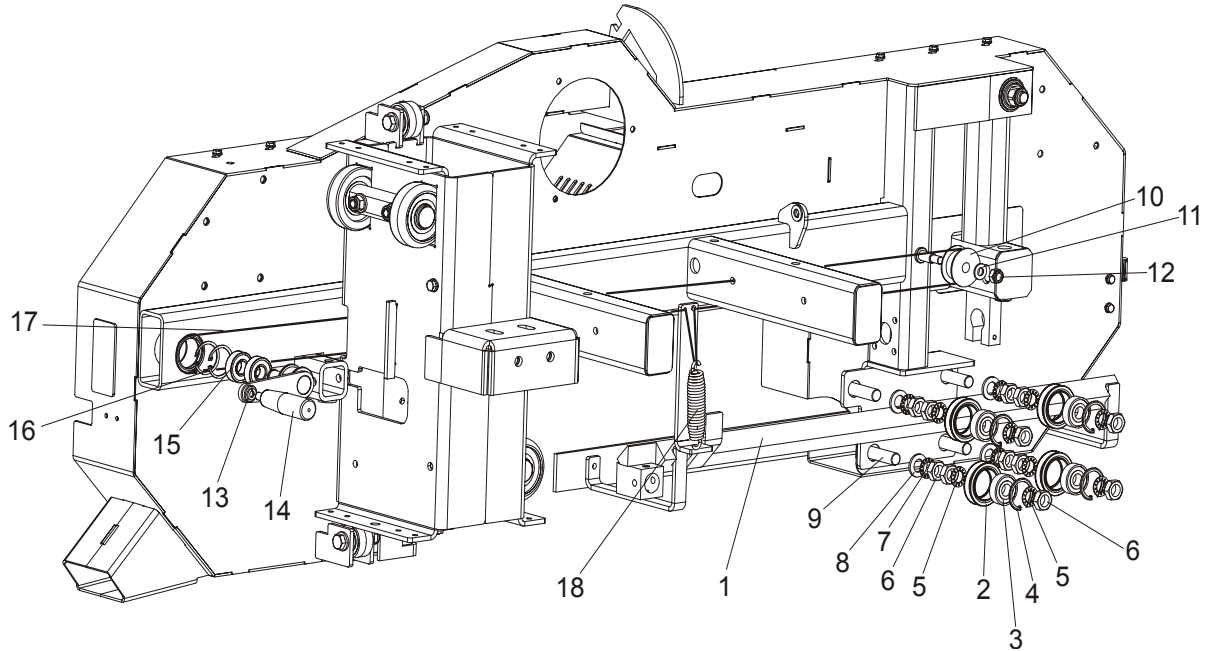

REF	DESCRIPTION (◆ Indicates Parts Available In Assemblies Only)	PART #	QTY.
1	ARM, LT20 BLADE GUIDE	090588-1	1
	ROLLER ASSEMBLY, BLADE GUIDE ARM V-GROOVE	A09059	4
2	Roller, V-Groove	S07989	4
3	Bearing, 6203-2 NSL 5/8	P06030-1	4
4	Ring, Retaining	F04254-8	4
5	WASHER, 5/8" INTERNAL STAR	F05011-25	8
6	NUT, 5/8"-18 HEX ZINC JAM	F05010-11	8
7	WASHER, 5/8" EXTERNAL STAR	F05011-26	4
8	WASHER, 17 ZINC FLAT	F81058-1	4
9	ROD, 5/8-18 THREADED	S12092	4
10	ROLLER, CHAIN GUIDE	014923	1
11	WASHER, 10.5 ZINC FLAT	F81055-1	1
12	NUT, M10-8-B HEX NYLON ZINC LOCK	F81033-1	1
	NUT, M10-8-B HEX NYLON ZINC LOCK	090611	1
13	CRANK WELDMENT, PAINTED	090610-1	1
14	HANDLE, 12992M10 CRANK	086338	1
15	BEARING, 6203-2RS FLT ROLLING	086114	2
16	RING, W40 SPRING RETAINING	F81090-3	2
17	ROPE, 4MM DIAMETER 007054	091613	1
18	SPRING, ROPE TENSION	091615	1

## SECTION 3 BLADE WHEELS & TENSIONER

### 3.1 Blade Wheel Assembly, Drive Side

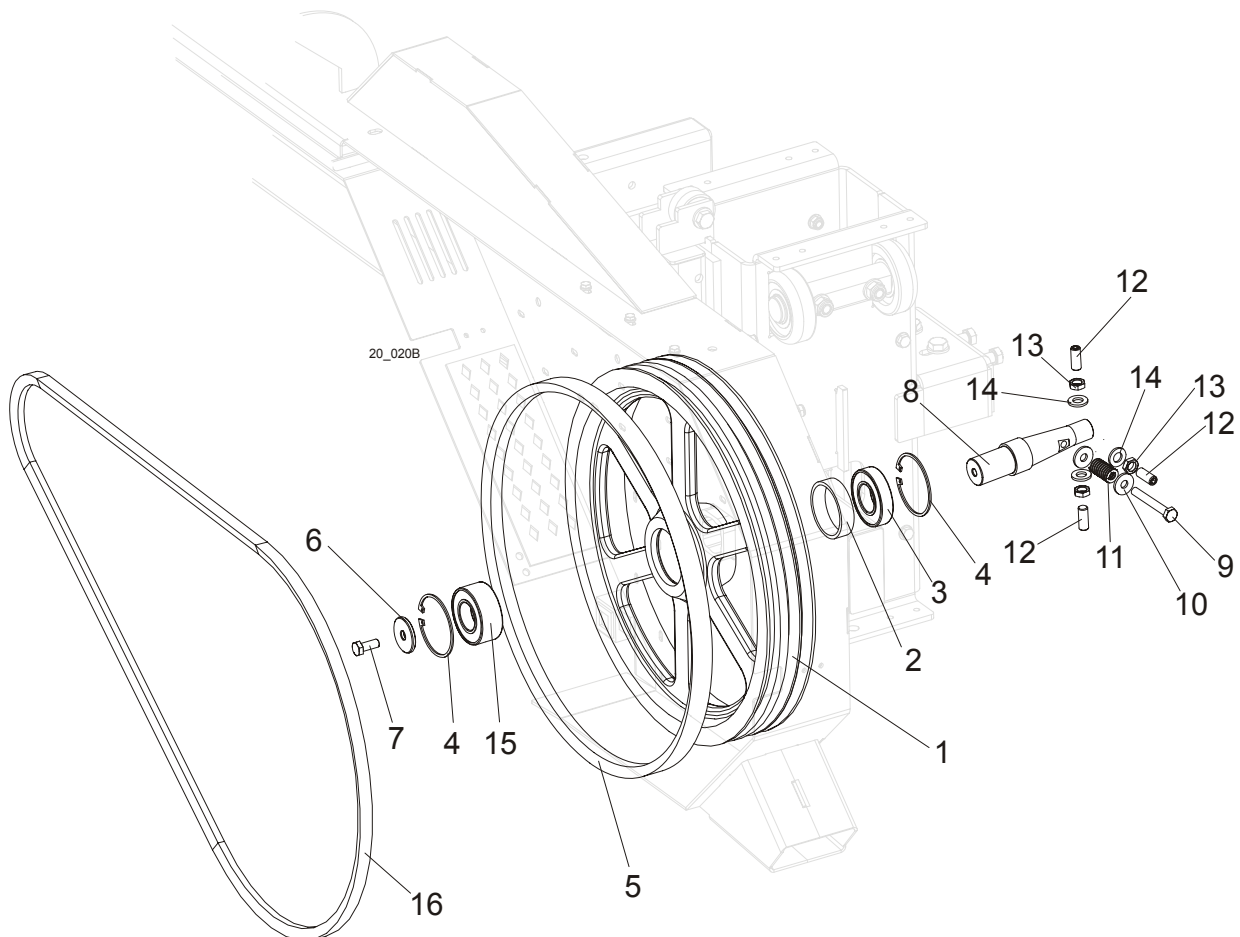

REF	DESCRIPTION (◆ Indicates Parts Available In Assemblies Only)	PART #	QTY.
	<b>BLADE WHEEL ASSEMBLY, LT20 DRIVE SIDE</b>	091612	1
1	Wheel, LT20 Drive Side Blade	090646-1	1
2	Bushing, Bearing Spacer	096778	1
3	Bearing, 6207 2RS 35x72x17 FAG	014811	1
4	Ring, W72 Retaining	F81090-4	2
5	Belt, B57 Blade Wheel	P04185	1
6	Washer, Drive Side Blade Wheel	092006	1
7	Bolt, M10x25-8.8 Hex Head Full Thread Zinc	F81003-11	1
8	Shaft, LT15/20 Drive Side Blade Wheel	093850	1
9	Bolt, M10x75-8.8 Hex Head Zinc	F81003-15	1
10	Washer, 10.5 Special Flat Zinc	F81055-6	2
11	Spring, 19x38 Compression	034430	1
12	Screw, M12x1,25x30 DIN913 Set	F81016-1	4

<b>13</b>	Washer, 13 Flat Zinc	F81056-1	4	
<b>14</b>	Nut, M12x1,25 DIN439 Thin Stainless Steel	F81034-9	4	
<b>15</b>	Bearing, 3207B, 2RSR. TVH FAQ	092005	1	
<b>16</b>	Drive Belt, BX81, AC Sawmills ( E11/E15 )	014819 ( AC )	1/2	
	Drive Belt, BX83, DC Sawmills ( G13 & G15 )	088110 ( DC )	1	
	Drive Belt, 2BX84, DC Sawmills ( D17, D22 & G18 )	092697 ( DC )	1	

### 3.2 Blade Wheel Assembly, Idle Side

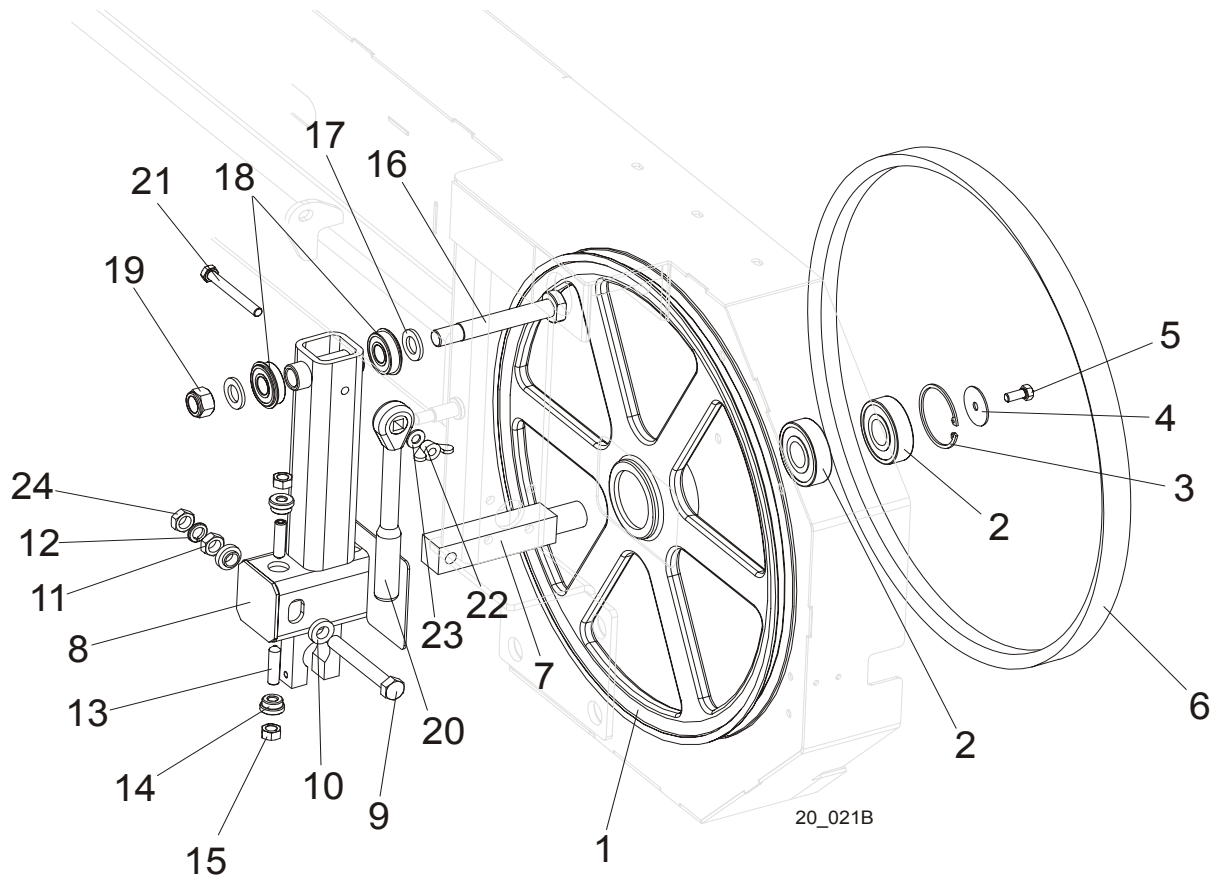

REF	DESCRIPTION (◆ Indicates Parts Available In Assemblies Only)	PART #	QTY.
	<b>WHEEL ASSEMBLY, IDLE SIDE BLADE</b>	A08218	1
1	Sheave, 18.62" Idler	P08125	1
2	Bearing, 6305 2RS NSK	P08066	2
3	Ring, 2 7/16" Inside Retaining	F04254-21	1
4	<b>WASHER, WHEEL RETAINING ZINC-PLATED</b>	093854-1	1
5	<b>BOLT, M8 x 25mm HEX HEAD GR 5.8 ZINC</b>	F81002-5	1
6	<b>BELT, B57 BLADE WHEEL</b>	P04185	1
7	<b>SHAFT, IDLE SIDE WHEEL METRIC</b>	096045	1
8	<b>HOUSING, IDLER SHAFT</b>	091595	1
9	<b>BOLT, M12X1.25X100-8.8 HEX HEAD FULL THREAD ZINC</b>	F81004-41	1
10	<b>SPACER, FLANGED ZINC-PLATED</b>	086769-1	2
11	<b>NUT, M12 X 1.25-8 HEX ZINC</b>	F81034-8	1
12	<b>WASHER, 12.2 SPLIT ZINC LOCK</b>	F81056-2	1
13	<b>SCREW, M10 X 40-45H HEX SOCKET SET CONE POINT ZINC</b>	F81003-61	2
14	<b>BUSHING, M10 IDLER SHAFT HOUSING</b>	086987	2
15	<b>NUT, M10-8-B HEX ZINC</b>	F81033-3	2
16	<b>PIN, IDLER ARM BEARINGS</b>	086404	1
17	<b>WASHER, 17 FLAT ZINC</b>	F81058-1	2

18	BEARING, 6203-2RS NR NSK W/RING	086395	2	
19	NUT, M16-8 HEX NYLON ZINC LOCK	F81036-2	1	
20	WRENCH, LT20 BLADE TENSION	091620	1	
21	BOLT, M10x90-8.8-B HEX HEAD ZINC	F81003-66	1	
22	STUD, M10x25-8.8 ZINC-PLATED	F81003-8	1	
23	WASHER, M10 FLAT ZINC	F81055-1	1	
24	NUT, M12x1.25 DIN439 THIN STAINLES STEEL	F81034-9	1	

**3.3 Blade Tensioner Assembly**

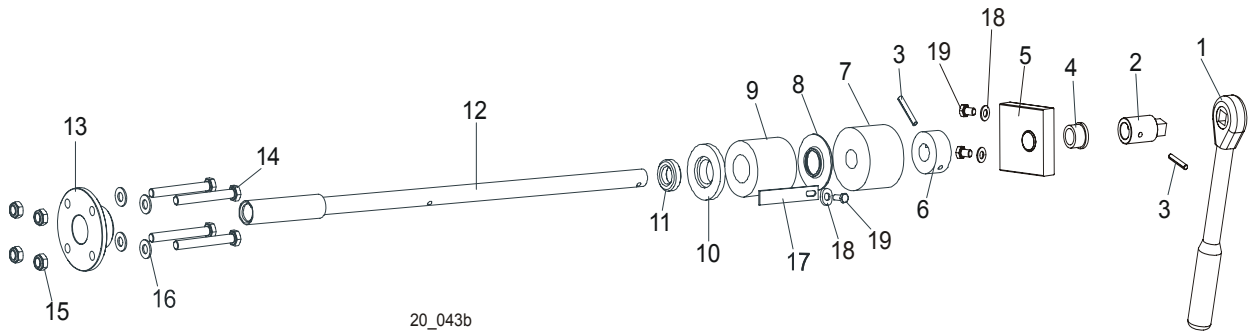

REF	DESCRIPTION (◆ Indicates Parts Available In Assemblies Only)	PART#	QTY.
	<b>BLADE TENSIONER ASSEMBLY</b>	090587	1
1	Wrench, LT20 Blade Tension	091620	1
2	End, LT20 Blade Tensioner Shaft	091606-1	1
3	Pin, 5 x 30 Zinc Roll	F81044-21	2
	Bracket, Tension Handle Mount w/Bushing	096729	1
4	Bushing GFM-1618-17(IGUS)	089589	1
5	Bracket, Painted	096730	1
6	Collar, Blade Tensioner	086712-1	1
7	Bushing, Rubber Stop	P12165	1
8	Guide, LT15 Tension Handle	014925	1
9	Spring, LT15 Rubber Blade Tensioner	014828	1
10	Washer, Rubber Spring Front	086674-1	1
11	Bearing, 51103 FLT Ball Thrust	086675	1
12	Shaft Weldment, Blade Tensioner Zinc-plated	086669-1	1
13	Nut, Blade Tensioner	086672-1	1
14	Bolt, M8x70 8.8 Hex Head Zinc	F81002-71	4
15	Nut, M8-8-B Hex Nylon Zinc Lock	F81032-2	4
16	Washer, 8.4 Zinc Flat	F81054-1	8
17	Indicator, LT15 Blade Tension Zinc-plated	086783-1	1
18	Washer, 6.4 Zinc Flat	F81053-1	1
19	Bolt, M6x16 8.8 Hex Head Full Thread Zinc	F81001-15	1

## SECTION 4 SAW HEAD

### 4.1 Middle Throat Screw

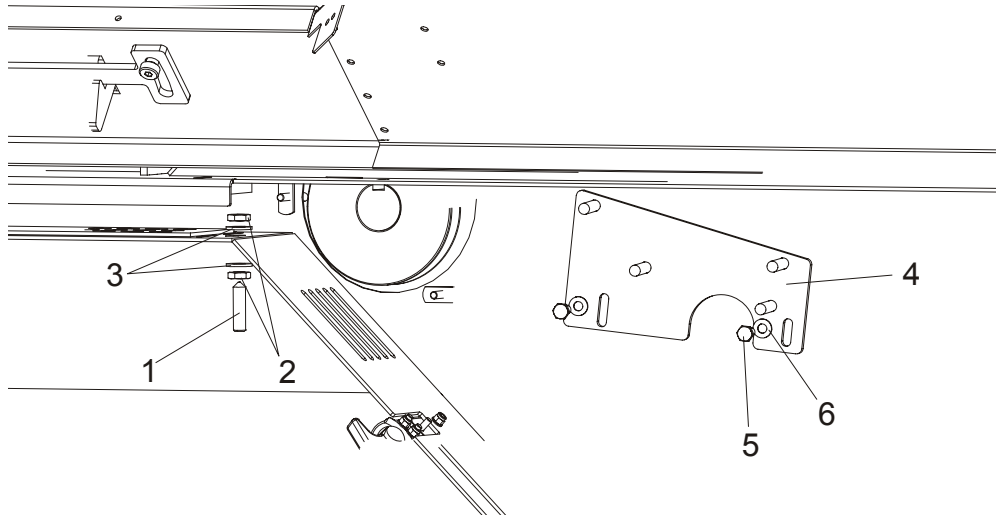

REF	DESCRIPTION (◆ Indicates Parts Available In Assemblies Only)	PART #	QTY.	
1	SCREW, M10 X 40-45H HEX SOCKET SET CONE POINT ZINC	F81003-61	1	
2	NUT, M10-8-B ZINC HEX	F81033-6	2	
3	WASHER, 10.5 ZINC FLAT	F81055-1	2	
4	BRACKET, DRIVE BELT SUPPORT, UPPER	092668-1	1	
5	BOLT, M8X20-5.8 HEX HEAD FULL THREAD ZINC	F81002-1	2	
6	WASHER, 8.4 ZINC FLAT	F81054-1	2	

## 4.2 Drive Belt Tensioner, DC Sawmills

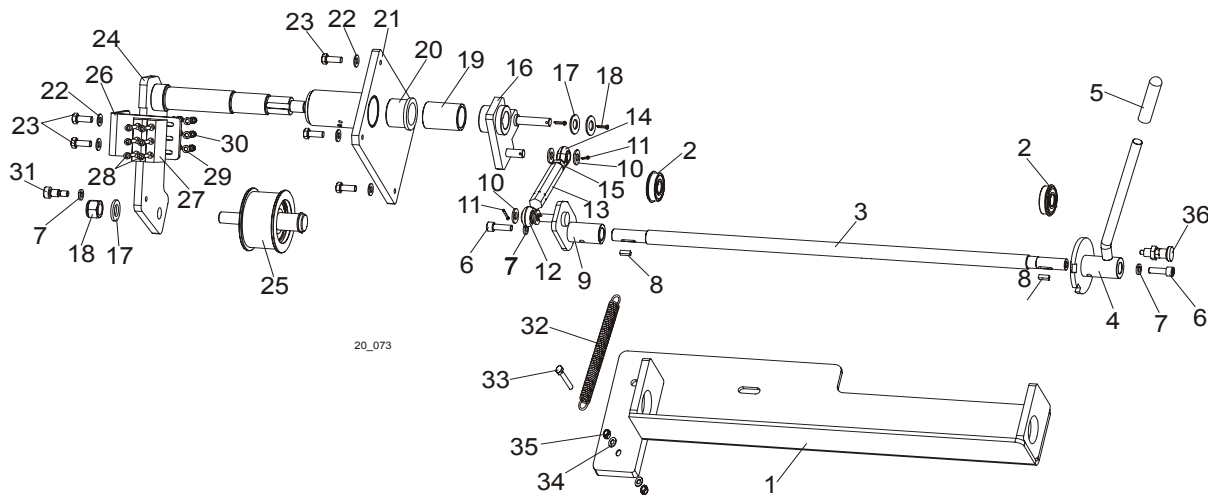

REF	DESCRIPTION (◆ Indicates Parts Available In Assemblies Only)	PART #	QTY.
	<b>BELT TENSIONER, LT20 COMPLETE</b>	091170	1
1	Mount Weldment, Belt Tensioner Ptd	091169-1	1
2	Bearing, 6203-2RS NR NSK w/Ring	086395	2
3	Rod, LT20 Belt Tensioner Ptd	091176-1	1
4	Handle Weldment, Belt Tensioner Ptd	087645-1	1
5	Grip, Handle 1/2" ID x 3" Long	014835	1
6	Screw, M8x25 -8.8 Hex Socket Head Cap Zinc	F81002-21	2
7	Washer, 8.2 Split Lock Zinc	F81054-4	3
8	Key, B 5x5.1x14 Parallel	087365	2
9	Bracket, Belt Tensioner Pivot	091245-1	1
10	Washer, 10.5 Zinc Flat	F81055-1	4
11	Pin, 2.5x20 Zinc Cotter	F81043-1	2
12	Rod End, 7/16-20 Right-Hand Male	P11579	1
13	Tumbuckle, Clutch/Brake	S11577	1
14	Rod End, 7/16-20 Left-Hand Male	P11578	1
15	Nut, 7/16-20 Zinc	F05010-38	1
16	Arm Weldment, Belt Tensioner Ptd	091172-1	1
17	Washer, 17 Zinc Flat	F81058-1	2
18	Nut, M16-8 Hex Nylon Zinc Lock	F81036-2	2
19	Bushing, Spacer Ptd	091351-1	1
20	Bushing, MFM-3240-30 (IGUS)	088461	2
21	Mount Weldment, Tensioner Shaft Ptd	091112-1	1
22	Washer, 8.4 Zinc Flat	F81054-1	7
23	Bolt, M8x20-5.8 Hex Head Full Thread Zinc	F81002-1	6
24	Shaft Weldment, Belt Tensioner Ptd	091110-1	1
25	Wheel, Belt Tension	087673	1
26	Bracket, Brake Block Mount Ptd	091248-1	1



<b>27</b>	Block, F9150 123 Belt Tensioner Brake	087648	2	
<b>28</b>	Screw, M5x25-8.8 Hex Socket Head Cap Zinc	F81000-7	6	
<b>29</b>	Washer, 5.3 Zinc Flat	F81052-1	6	
<b>30</b>	Nut, M5-8 Zinc DIN 985	F81030-2	6	
<b>31</b>	Screw, M8x25-8.8 Hex Socket Head Cap Zinc	F81002-21	2	
<b>32</b>	Spring, Hydraulic Log Turner	P09136	1	
<b>33</b>	Bolt, M8x45-8.8 Hex Head Zinc	F81002-17	1	
<b>34</b>	Washer, 8.4 Zinc Flat	F81054-1	2	
<b>35</b>	Nut, M8-8-B Hex Nylon Zinc Lock	F81032-2	2	
<b>36</b>	Pin, Detent	090197	1	

## 4.3 Water Lube Assembly

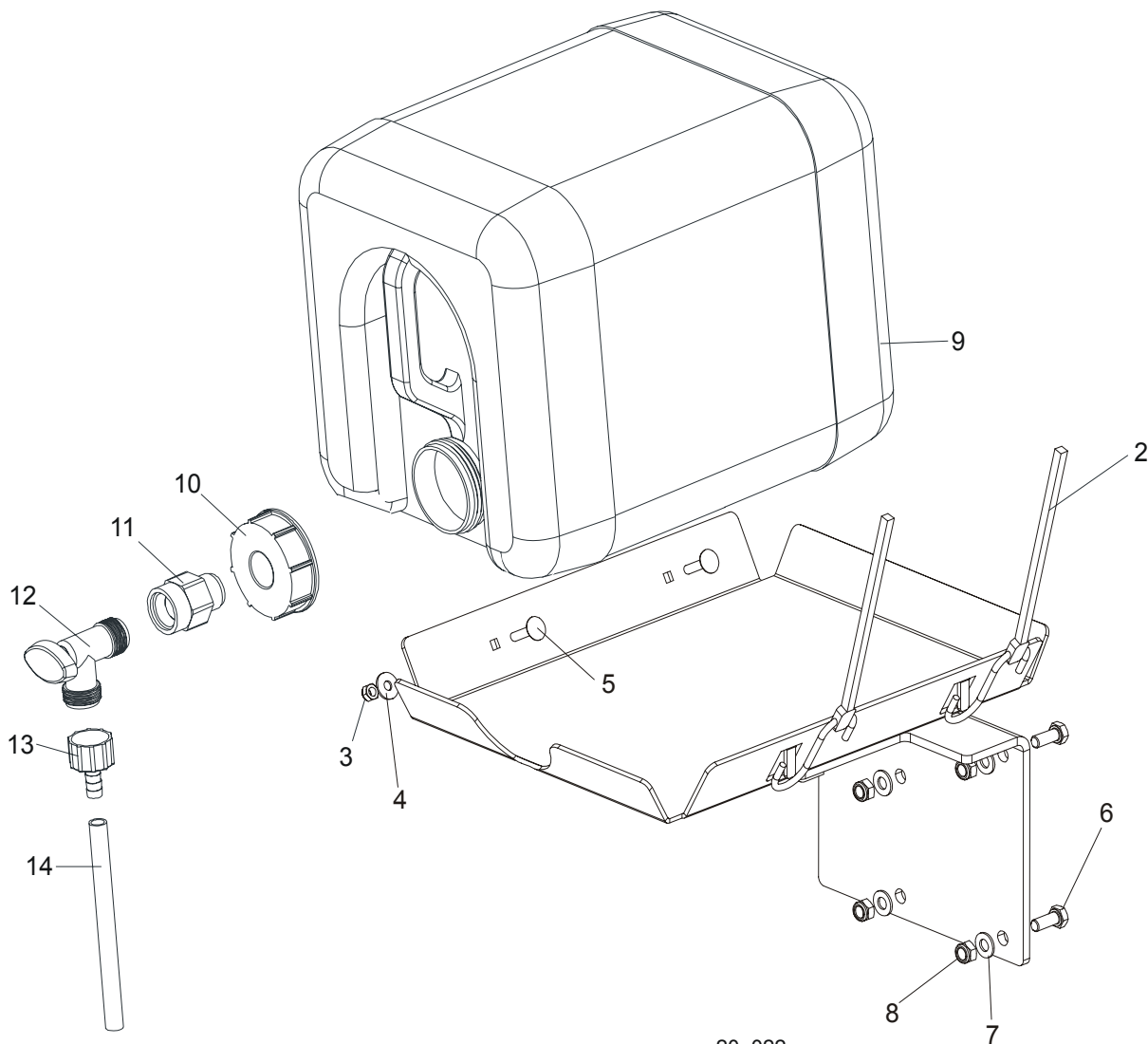

20\_022

REF	DESCRIPTION (◆ Indicates Parts Available In Assemblies Only)	PART #	QTY.
	<b>BOTTLE KIT, LT20 WATER LUBE</b>	091036	1
1	Tray Weldment, LT20 Water Lube	091033-1	1
2	Strap, 20" Rubber	P11668	2
3	Nut, M6-8-B Hex Nylon Zinc Lock	F81031-2	2
4	Washer, 6.5 Zinc Flat	F81053-11	2
5	Bolt, M6x25-8.8 Carriage Head Zinc	F81001-20	2
6	Bolt, M8x20-8.8 Hex Head Full Thread Zinc	F81002-1	2
7	Washer, 8.4 Zinc Flat	F81054-1	2
8	Nut, M8-8-B Hex Nylon Zinc Lock	F81032-2	2
	Bottle Assembly, Water Lube	014642	1
9	Bottle, 19 l Water Lube	014637	1
10	Cap, Water Lube Bottle Buttruss Thread	014773	1

<b>11</b>	Fitting, 3/4FPT x 3/4MPT	014636	1	
<b>12</b>	Fitting, Water Lube Shutoff Valve	014100	1	
<b>13</b>	Fitting, 5/8" NPT to 3/8" Hose Barb	014113	1	
<b>14</b>	Tubing, Water Lube	R01885	2.1 m	

# 4 Saw Head

## Saw Head Decals

### 4.4 Saw Head Decals

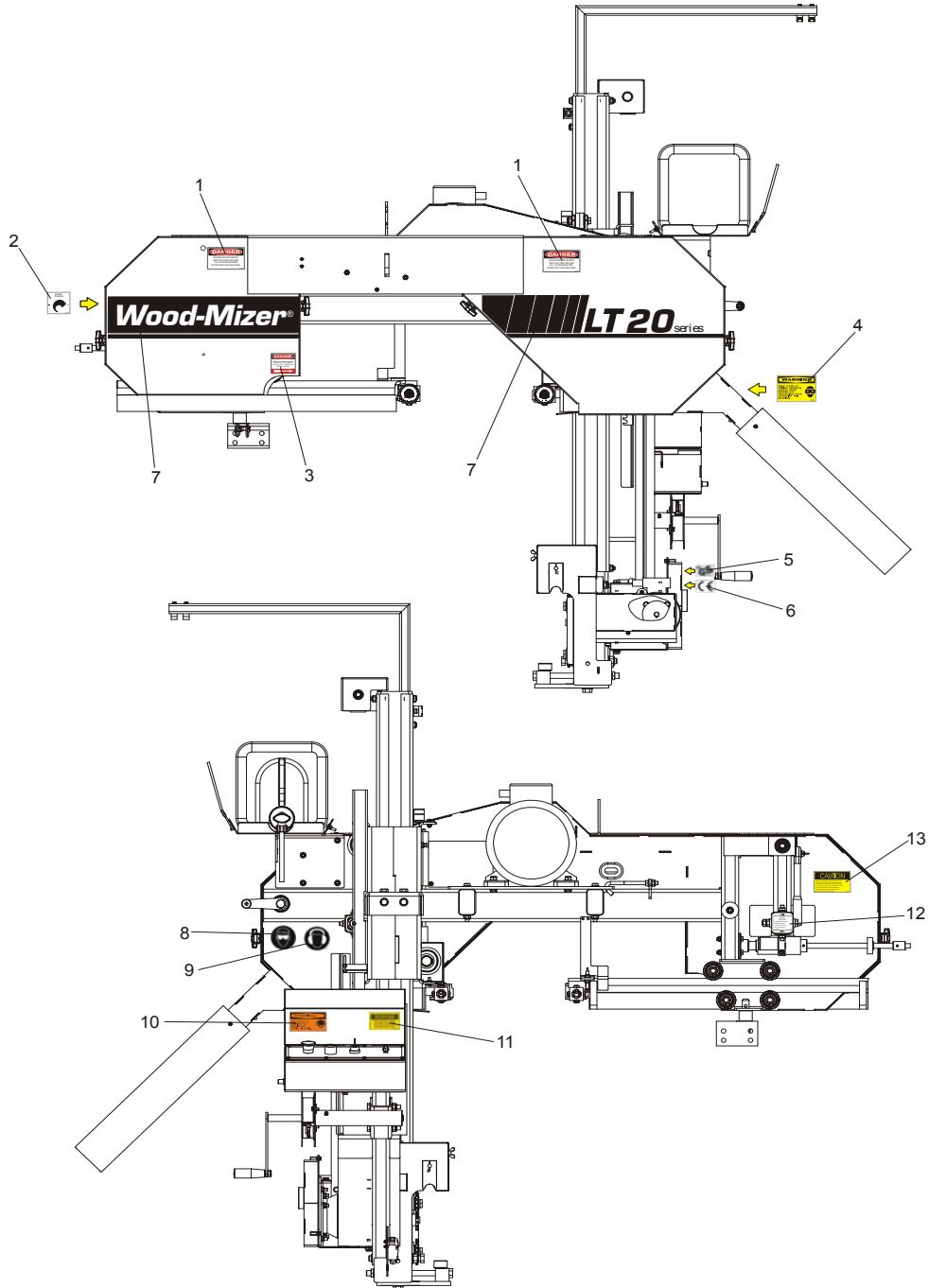

REF	DESCRIPTION (◆ Indicates Parts Available In Assemblies Only)	PART #	QTY.
1	DECAL, BLADE COVER DANGER	S20039	2
2	DECAL, BLADE TENSION SCREW	P11790	1
3	DECAL, BLADE DANGER (W/RIGHT ARROW)	S11752	1
4	DECAL, SAWDUST CHUTE CAUTION	P11754	1
5	DECAL, CE CERTIFIED SAWMILL	P85071	1
6	DECAL, GS SAFETY CERTIFICATION SMALL	P85072	1

7	DECAL KIT, LT20	091480	1	
8	DECAL, EYE PROTECTION (PICTOGRAM)	S12004	1	
9	DECAL, EAR PROTECTION (PICTOGRAM)	S12005	1	
10	DECAL, EYE/EAR PROTECTION WARNING	S11753	1	
11	DECAL, FRONT OUTRIGGER DANGER	015400	1	
12	DECAL, BLADE ALIGNMENT	P11789	1	
13	DECAL, SAW HEAD REST CAUTION	S12581	1	

## 4.5 Blade Housing Cover

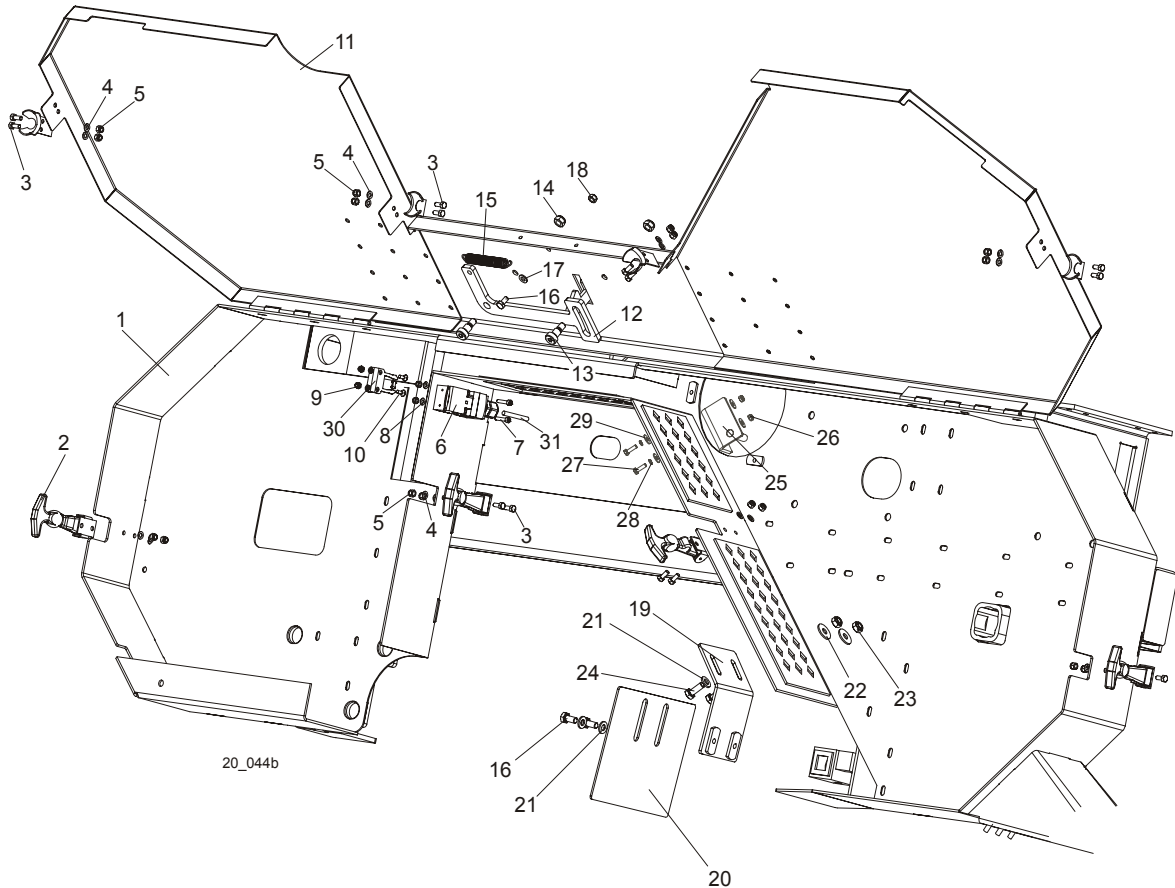

REF	DESCRIPTION (◆ Indicates Parts Available in Assemblies Only)	PART #	QTY.
1	SAW HEAD WELDMENT, LT20	090567	1
2	LATCH, FLEXIBLE DRAW	014829	4
3	BOLT, M5 X 12-5.8 HEX HEAD FULL THREAD ZINC	F81000-5	16
4	WASHER, 5.3 ZINC FLAT	F81052-1	16
5	NUT, M5-8 HEX NYLON ZINC LOCK	F81030-2	16
6	SWITCH, AZ17-11ZRK SAFETY KEY	094232	1
7	SCREW, M4 X 35 8.8 HEX SOCKET HEAD CAP ZINC	F81011-34	2
8	WASHER, 4.3 ZINC FLAT	F81051-2	4
9	NUT, M4-B HEX NYLON ZINC LOCK	F81029-1	4
10	SCREW, M4 X 12 5.8-B SLOTTED COUNTERSUNK HEAD ZINC	F81011-43	2
11	COVER WELDMENT, LT20 BLADE HOUSING PTD	090633-1	1
12	PAWL, LOCKING PTD	090643-1	1
13	SCREW, 10/M8 X 12-12.9 ISO-7379 SOCKET HEAD SHOULDER	F81003-62	2
14	NUT, M8-8-B HEX NYLON ZINC LOCK	F81032-2	2
15	SPRING, 1,6x12x38 EXTENSION	092208	1
16	BOLT, M6 X 12-8.8 HEX HEAD FULL THREAD ZINC	F81001-7	3

17	WASHER, 6.4 ZINC FLAT	F81053-1	1	
18	NUT, M6-8-B HEX NYLON ZINC LOCK	F81031-2	1	
19	BRACKET, BLADE GUIDE ROLLER GUARD PAINTED	092378-1	1	
20	GUARD, BLADE GUIDE ROLLER PAINTED	092379-1	1	
21	WASHER, 6.4 ZINC FLAT	F81053-1	4	
22	WASHER, 6.5 ZINC FLAT	F81053-11	2	
23	NUT, M6-8-B HEX NYLON ZINC LOCK	F81031-2	2	
24	BOLT, M6X16 8.8 HEX HEAD FULL THREAD ZINC	F81001-15	2	
25	BRACKET WLDMT, PTD DRIVE BELT SUPPORT	092636-1	1	
26	NUT, M6-8-B HEX NYLON ZINC LOCK	F81031-2	2	
27	BOLT, M6 X 20-8.8 HEX HEAD FULL THREAD ZINC	F81001-2	2	
28	WASHER 6,1 FE/ZN9 PN/M-82008	F81053-3	2	
29	WASHER, 6.5 ZINC FLAT	F81053-11	4	
30	KEY, AZ17/170-B5 SAFETY SWITCH	094422	1	
31	CABLE, OLFLEX 400P 2X1	R80583-5	3m (DC) 5m (AC)	

# 4

## Saw Head Control Box (AC Sawmills)

### 4.6 Control Box (AC Sawmills)

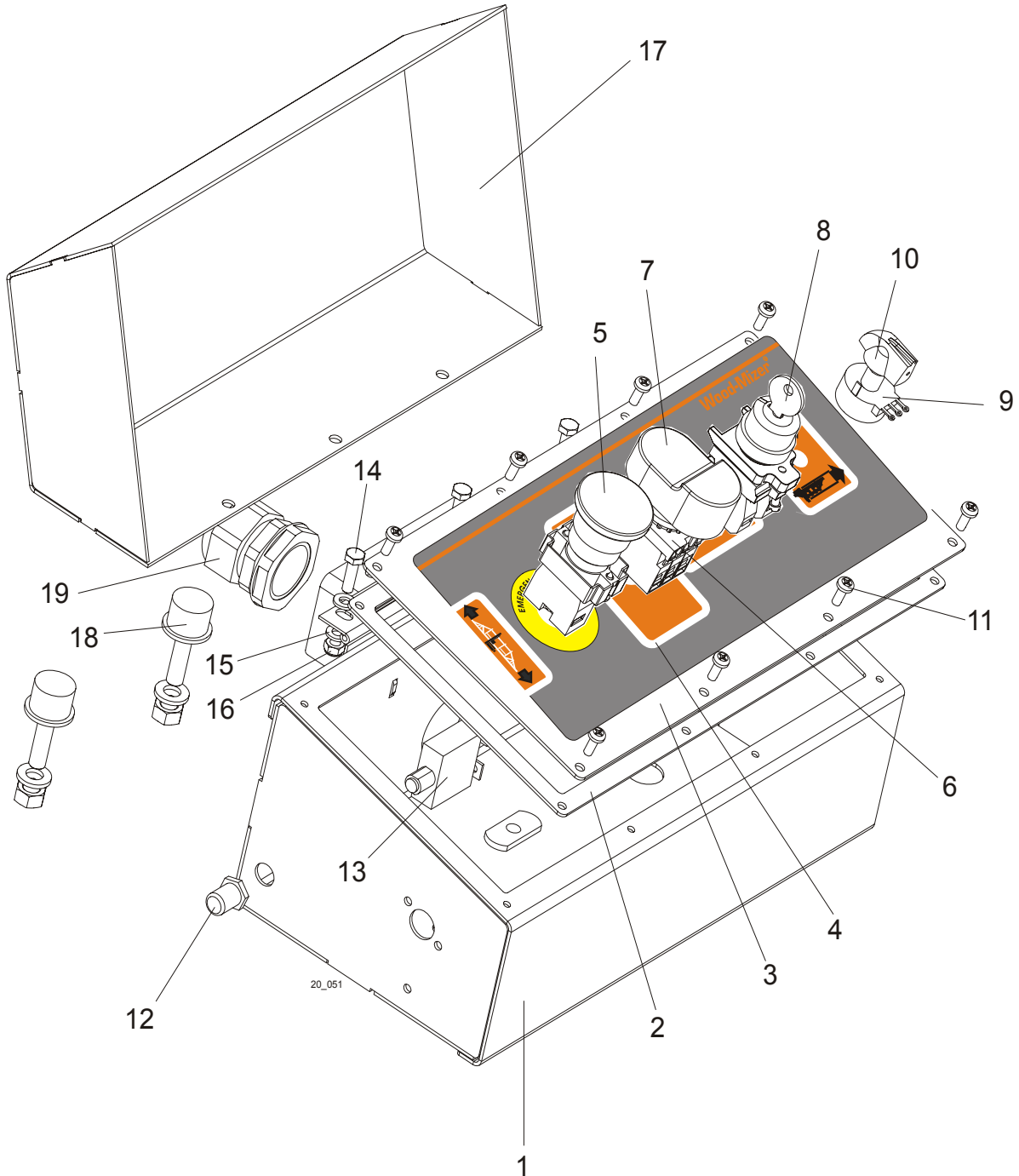

REF	DESCRIPTION (◆ Indicates Parts Available In Assemblies Only)	PART #	QTY.	
	<b>CONTROL BOX ASSEMBLY, LT20 AC</b>	<b>090737</b>	1	
1	Box Weldment, LT20 AC Control	090734-1	1	
2	Gasket, Control Box (9.5m Frame)	089998	1	
3	Panel, LT20 Front Control	090736	1	



4	Decal, LT20 Control Box	090735	1	
5	Button, XB4 BS542 Emergency Stop	086556	1	
6	Button, 24V Start/Stop	090452	1	
7	Membrane M22-T-DD	090462	1	
8	Switch, M22 3-position Key	091361	1	
	Contact, M22 - K10	091362	2	
9	Potentiometer, Feed Control	E20519	1	
10	Dial, Feed Rate	P06257	1	
11	Screw, #10-24 x 1/2 Pan Head	F05015-17	8	
12	Boot, Circuit Breaker	021253	1	
13	Breaker, 30Amp Manual Reset Circuit	024246	1	
14	Bolt, M6x20-8.8 Hex Head Full Thread Zinc	F81001-2	3	
15	Washer, 6.4 Zinc Flat	F81053-1	6	
16	Nut, M6-8-B Hex Nylon Zinc Lock	F81031-2	3	
17	Cover, Control Box	088172-1	1	
18	Bumper, A/022	088376	2	
19	Connector, Klick -GP21 rill 21 Polyamid Conduit	086577	1	

# 4 Saw Head

## Control Box (DC Sawmills)

### 4.7 Control Box (DC Sawmills)

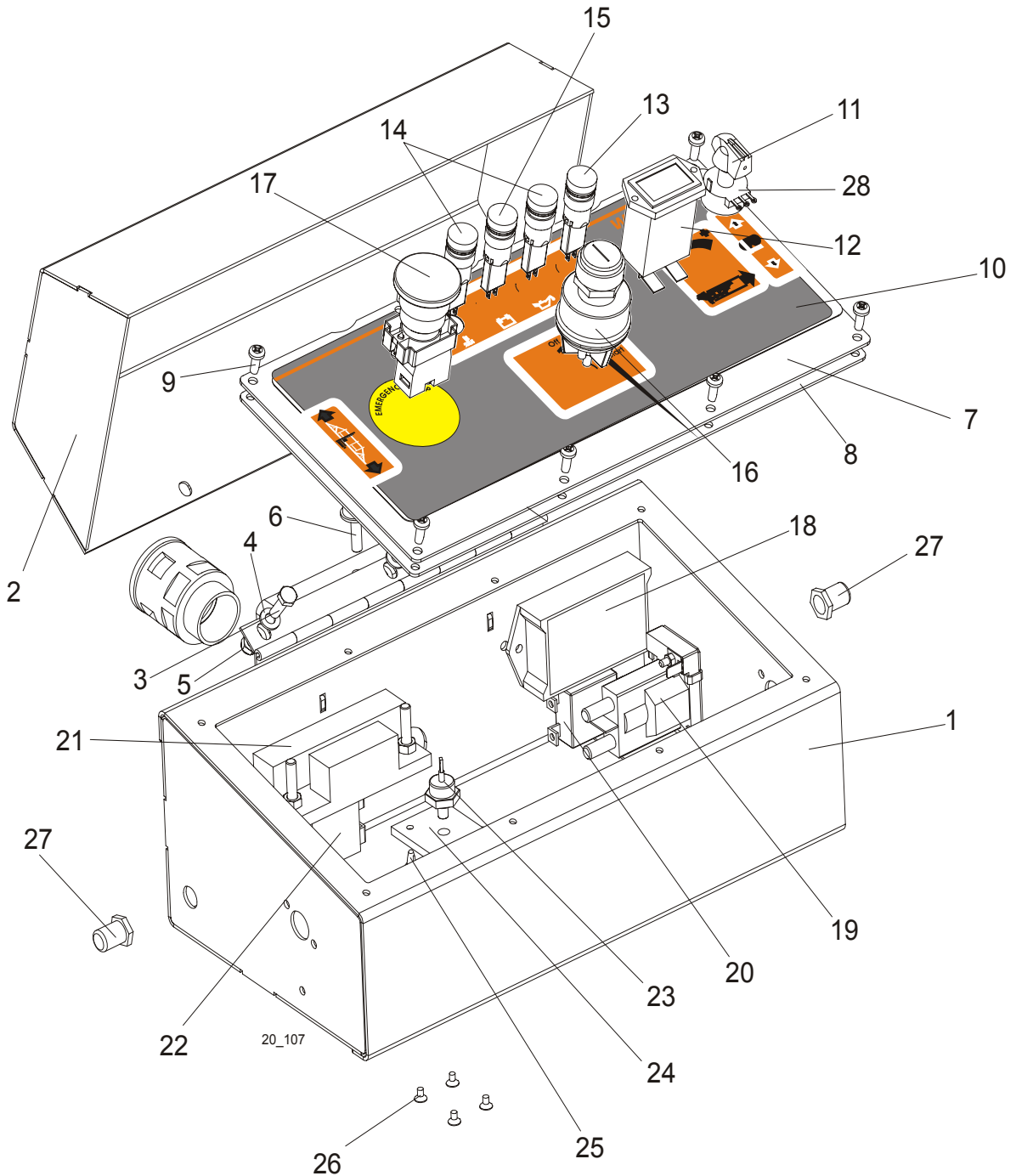

REF	DESCRIPTION (◆ Indicates Parts Available In Assemblies Only)	PART #	QTY.
	<b>CONTROL BOX ASSEMBLY, LT20 DC</b>	<b>090996</b>	<b>1</b>
1	Box Weldment, LT20 DC Painted Control	092947-1	1
2	Cover Weldment, Control Box Painted	092942-1	1

3	Bolt, M6x20-8.8 Hex Head Full Thread Zinc	F81001-2	3	
4	Washer, 6.4 Flat Zinc	F81053-1	6	
5	Nut, M6-8-B Hex Nylon Zinc Lock	F81031-2	3	
6	Bumper, A/022	088376	1	
7	Panel, LT20 DC Front Painted Control	090995-1	1	
8	Gasket, Control Box	089998	1	
9	Screw, #10-24 x 1/2 Pan Head	F05015-17	8	
10	Decal, LT20 DC Control Box	090997	1	
11	Knob, Speed Control	P06257	1	
12	Meter, Hour	093166	1	
13	Light, XB6AV5BB Yellow	089812	1	
14	Light, KLA-RS-10-2	090998	2	
15	Light, XB6 AV 3BB Green	087348	1	
16	Switch, Key	P04350	1	
17	Button, XB4 BS542 Emergency Stop	086556	1	
18	Control Module, Power Feed SMT	024396	1	
19	Solenoid, 120-943 Continuous Duty GND Coil	P10449	1	
20	Breaker, 50A Manual Reset	021256	1	
21	Module, Mosfet Power Feed	024540	1	
22	Breaker, 30A Manual Reset	024246	1	
23	Diode, 1N11184A 40A 110V	E07766	1	
24	Heatsink, Diode	091867	1	
25	Spacer, P3/12	R80671-2	4	
26	Screw, FH ST 3.5x6.5 A4 Cross Recessed Countersunk Head Tapping	F81000-82	4	
27	Boot, Circuit Breaker	021253	1	
28	Potentiometer, 1k	E20519	1	

# 4 Saw Head

## Drum Switches

### 4.8 Drum Switches

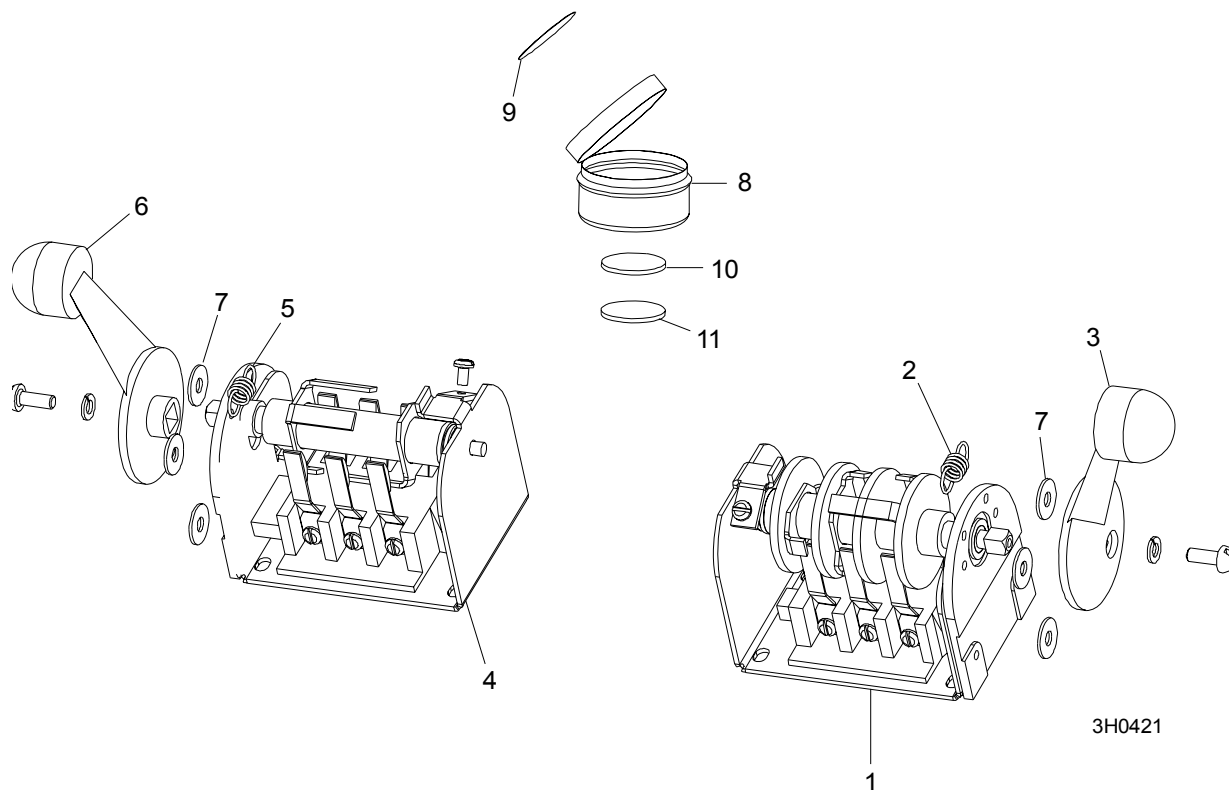

REF	DESCRIPTION (◆ Indicates Parts Available In Assemblies Only)	PART #	QTY.	
	<b>SWITCH ASSEMBLY, UP/DOWN DRUM</b>	E20440	1 (AC) 2 (DC)	
1	Switch, Drum	E20440-B	1	◆
2	Spring, Drum Switch	P12570	1	
3	Handle, Drum Switch w/Screws	P12500	1	
	<b>SWITCH ASSEMBLY, POWER FEED DRUM</b>	E20438	1 (AC) 0 (DC)	
4	Switch, Drum	E20438-B	1	◆
5	Spring, Drum Switch	P12570	1	
6	Handle, Drum Switch w/Screws	P12500	1	
7	<b>WASHER, #8 SAE FLAT</b>	F05011-41	6	
	<b>CUP ASSEMBLY, DRUM SWITCH GREASE</b>	A20463	1	
8	Cup, Plastic Container	P20464	1	◆
9	Label, Grease Cup	P20467	1	
10	Pad, Velcro Loop	P20466	1	◆
11	Pad, Velcro Hook	P20465	1	◆
	Grease, Drum Switch	P20468	.011ml	◆

## 4.9 Sawdust Chute

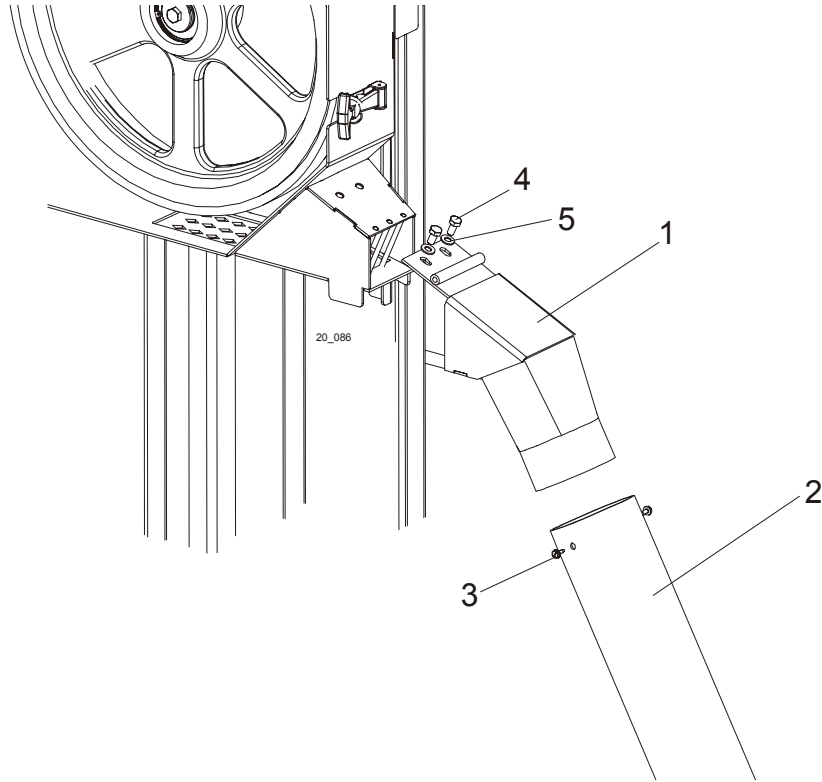

REF	DESCRIPTION (◆ Indicates Parts Available In Assemblies Only)	PART #	QTY.
1	CHUTE WELDMENT, SAWDUST	092460-1	1
2	TUBE, SAWDUST CHUTE RUBBER	R02336	1
3	SCREW, #10-24 X 1/2 SELF-TAPPING	F05015-7	2
4	BOLT, M8x16	F81002-20	2
5	WASHER, 8.4 ZINC FLAT	F81054-1	2

## SECTION 5 UP/DOWN ASSEMBLY

### 5.1 Up/Down Assembly, AC Mills

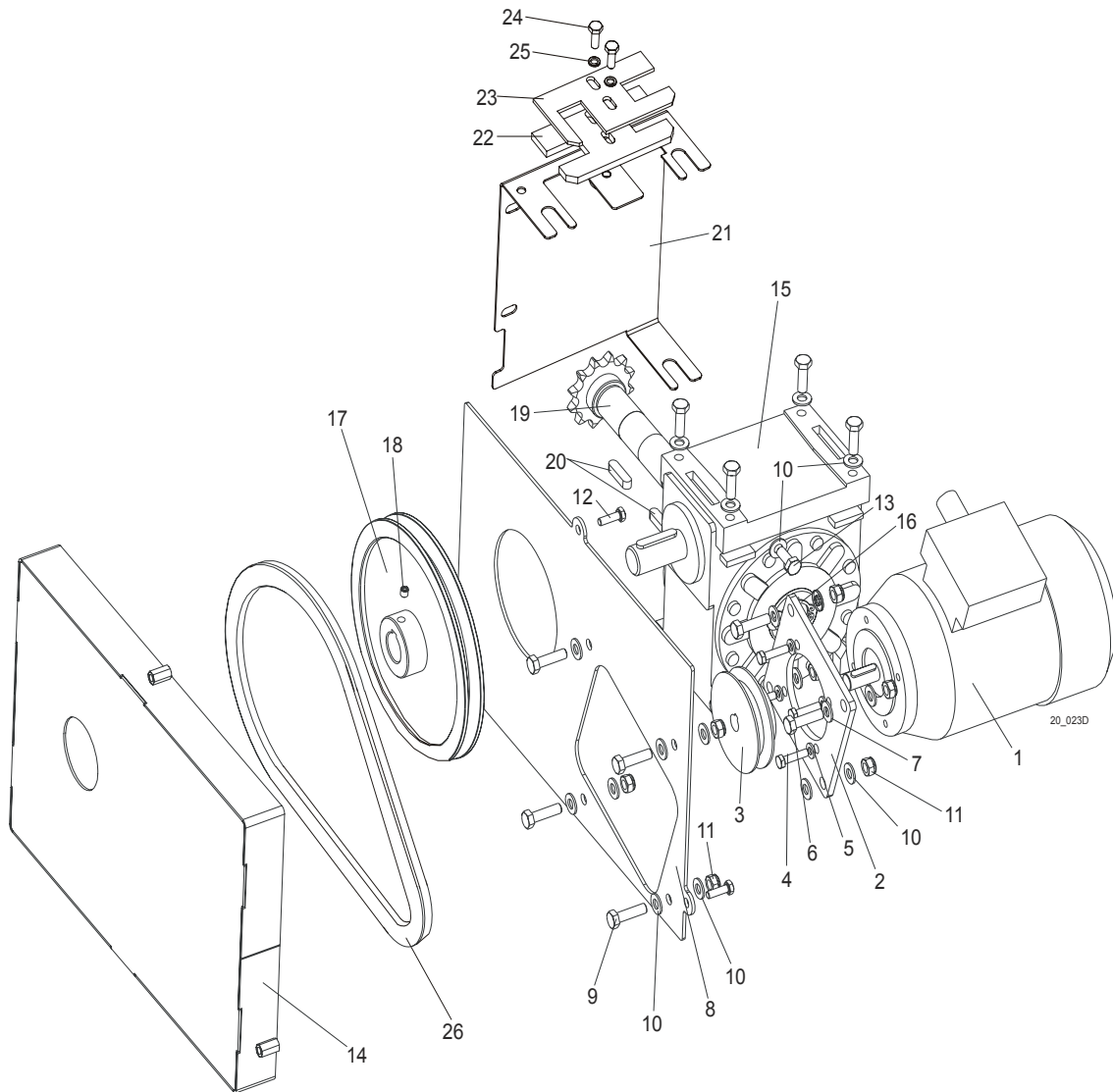

REF	DESCRIPTION (◆ Indicates Parts Available In Assemblies Only)	PART #	QTY.	
	<b>MOTOR ASSEMBLY, LT20 AC UP/DOWN</b>	091302	1	◆
1	Motor, SKh 71- 4B2 RAL 9005	091304	1	
2	Plate, LT20 AC Up/Down Motor Mount Ptd	091300-1	1	
3	Pulley, LT20	090699	1	
4	Bolt, M6x25-5.8 Hex Head Full Thread Zinc	F81001-3	4	
5	Washer 6.4 Zinc Flat	F81053-1	4	
6	<b>BOLT, M8X30-5.8 HEX HEAD FULL THREAD ZINC</b>	F81002-2	4	
7	<b>WASHER, 8.4 ZINC FLAT</b>	F81054-1	4	
8	<b>PLATE, LT20 BELT GUARD MOUNT</b>	091079-1	1	

<b>9</b>	<b>BOLT, M8X30-5.8 HEX HEAD FULL THREAD ZINC</b>	F81002-2	4	
<b>10</b>	<b>WASHER, 8.4 ZINC FLAT</b>	F81054-1	12	
<b>11</b>	<b>NUT, M8-8-B HEX NYLON ZINC LOCK</b>	F81032-2	4	
<b>12</b>	<b>BOLT, M6X20-8.8 HEX HEAD FULL THREAD ZINC</b>	F81001-2	4	
<b>13</b>	<b>BOLT, M8X20-5.8 HEX HEAD FULL THREAD ZINC</b>	F81002-1	2	
<b>14</b>	<b>GUARD WELDMENT, LT20 UP/DOWN BELT PTD</b>	091080-1	1	
	<b>BOX ASSEMBLY, LT20 UP/DOWN GEAR</b>	091299	1	
<b>15</b>	Box, RA-06/66/D1/S+N/V5 Gear	088577	1	
<b>16</b>	Ring, Z30 Spring Retaining	F81090-23	1	
<b>17</b>	Pulley, LT20 Up/Down	091078	1	
<b>18</b>	Screw, M8X8-33H Hex Socket Set Flat Point	F81014-1	1	
<b>19</b>	Shaft, LT20 Up/Down w/Sprocket	091298	1	
<b>20</b>	Key, A8x7x32 Parallel	088564	2	
	<b>GUARD, LT20 UP/DOWN GEAR BOX SPROCKET COMPLETE</b>	096961	1	
<b>21</b>	Guard, LT20 Up/Down Gear Box Sprocket	096383-1	1	
<b>22</b>	Wiper, LT20 Up/Down Chain	096384	1	
<b>23</b>	Plate, LT20 Wiper Assy	096958-1	1	
<b>24</b>	Bolt, M6x16 8.8 Fe/Zn5 PN-M/82105	F81001-15	2	
<b>25</b>	Washer, M6 Split Lock Zinc	F81053-3	2	
<b>26</b>	<b>BELT, HA-560 (STOMIL-SANOK)</b>	088562	1	

## 5.2 Up/Down Assembly, DC Mills

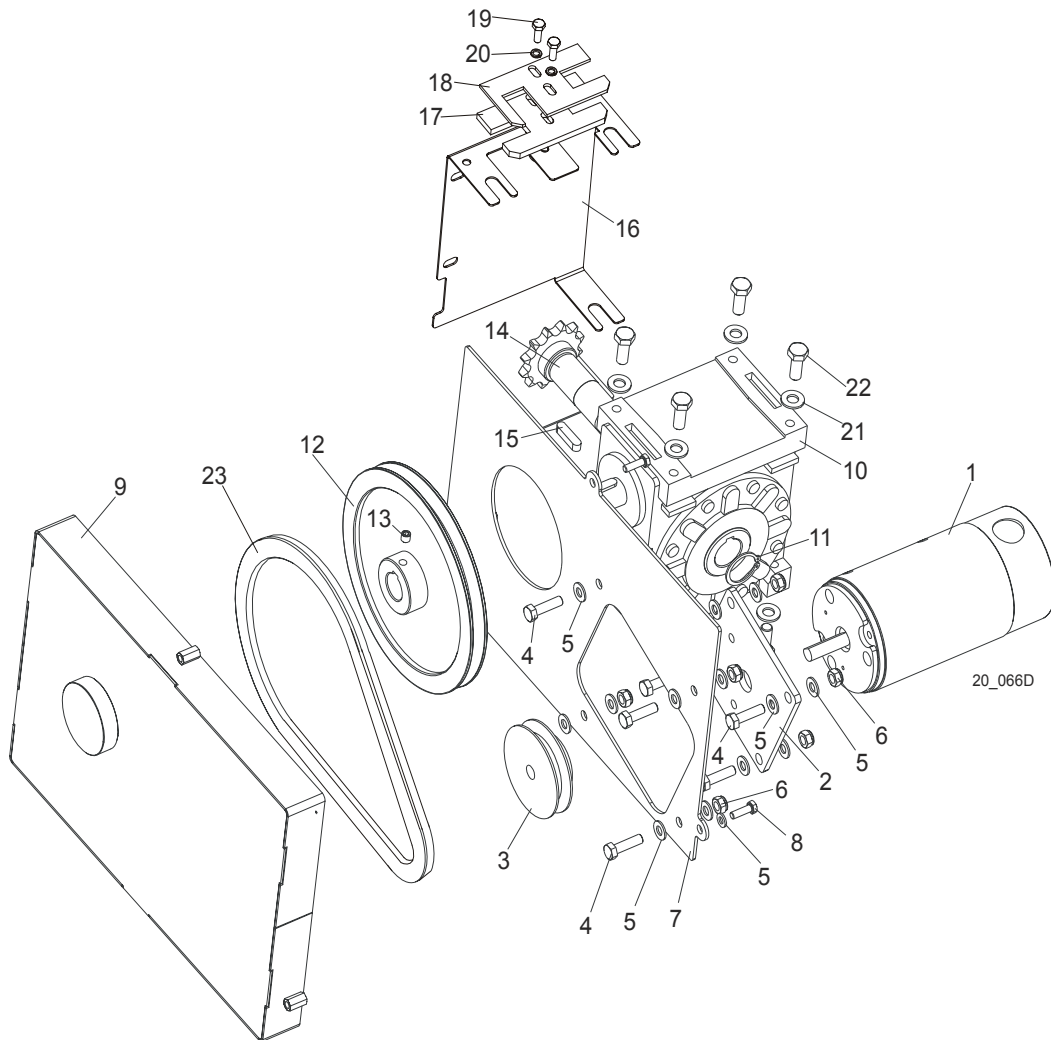

REF	DESCRIPTION (◆ Indicates Parts Available In Assemblies Only)	PART #	QTY.	
	<b>MOTOR ASSEMBLY, LT20 DC UP/DOWN</b>	091303	1	◆
1	Motor, Drive 12V 0.5HP	P04140	1	
2	Plate, LT20 DC Up/Down Motor Mount Ptd	091301-1	1	
3	Sheave, Up/Down Motor "A" 82/12.7 Ptd	093158-1	1	
4	<b>BOLT, M8X30-5.8 HEX HEAD FULL THREAD ZINC</b>	F81002-2	8	
5	<b>WASHER, 8.4 ZINC FLAT</b>	F81054-1	19	
6	<b>NUT, M8-8-B HEX NYLON ZINC LOCK</b>	F81032-2	8	
7	<b>PLATE, LT20 BELT GUARD MOUNT</b>	091079-1	1	
8	<b>BOLT, M6X20-8.8 HEX HEAD FULL THREAD ZINC</b>	F81001-2	3	
9	<b>GUARD WELDMENT, LT20 UP/DOWN BELT PTD</b>	091080-1	1	
	<b>BOX ASSEMBLY, LT20 UP/DOWN GEAR</b>	091299	1	
10	Box, RA-06/66/D1/S+N/V5 Gear	088577	1	
11	Ring, Z30 Spring Retaining	F81090-23	1	



<b>12</b>	Pulley, LT20 Up/Down	091078	1	
<b>13</b>	Screw, M8x8-33H Hex Socket Set Flat Point	F81014-1	1	
<b>14</b>	Shaft, LT20 Up/Down w/Sprocket	091298	1	
<b>15</b>	Key, A8x7x32 Parallel	088564	2	
	<b>GUARD, LT20 UP/DOWN GEAR BOX SPROCKET COMPLETE</b>	096961	1	
<b>16</b>	Guard, LT20 Up/Down Gear Box Sprocket	096383-1	1	
<b>17</b>	Wiper, LT20 Up/Down Chain	096384	1	
<b>18</b>	Plate, LT20 Wiper Assy	096958-1	1	
<b>19</b>	Bolt, M6x16 8.8 Fe/Zn5 PN-M/82105	F81001-15	2	
<b>20</b>	Washer, M6 Split Lock Zinc	F81053-3	2	
<b>21</b>	<b>WASHER, FLAT, M10, ZINC</b>	F81055-1	6	
<b>22</b>	<b>BOLT, M10-1.5X25MM HH GR8.8</b>	F81003-11	6	
<b>23</b>	<b>BELT, HA-560 (STOMIL-SANOK)</b>	088562	1	

### 5.3 Manual Up/Down System

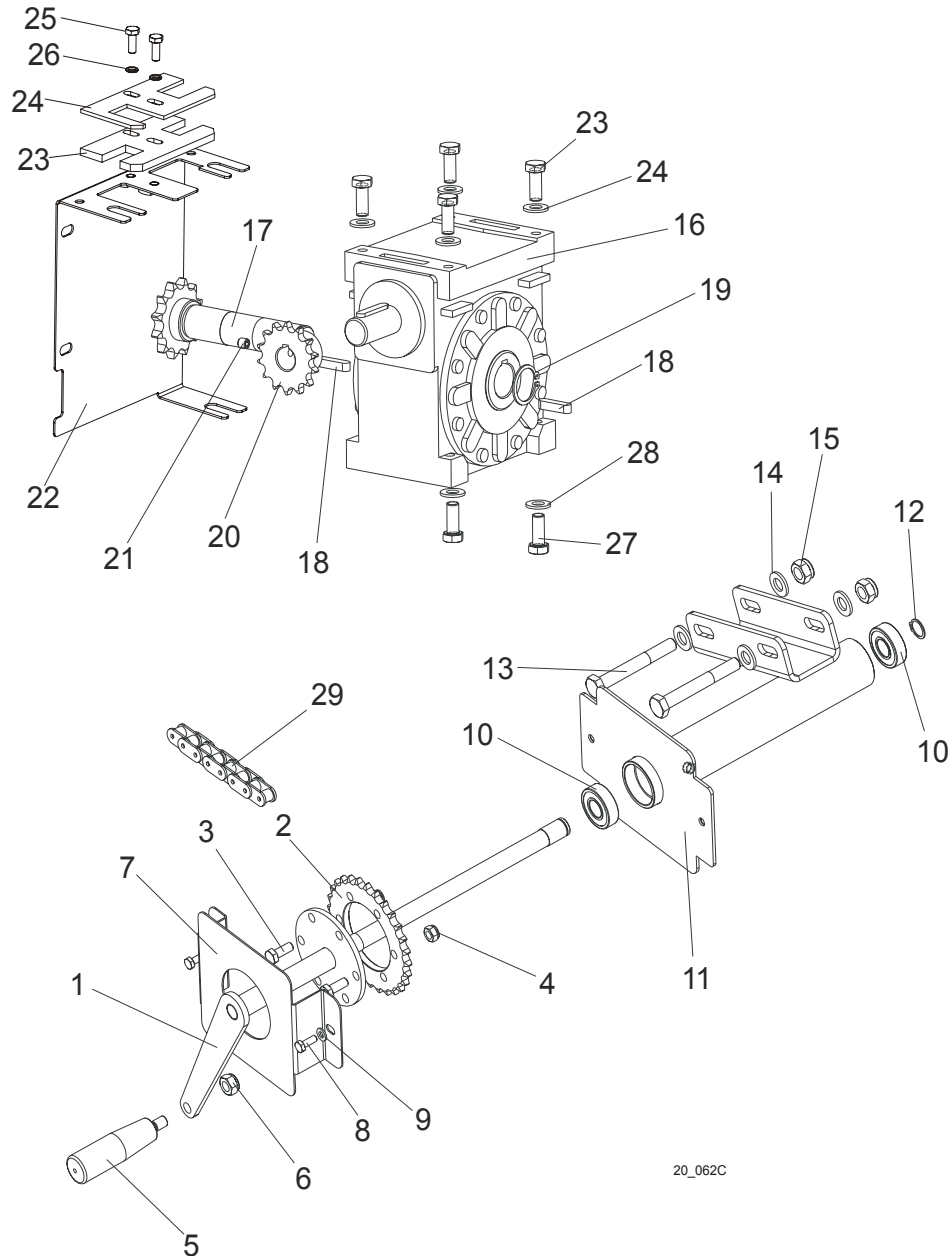

20\_062C

REF	DESCRIPTION (◆ Indicates Parts Available In Assemblies Only)	PART #	QTY.
	<b>CRANK ASSEMBLY, LT20 UP/DOWN</b>	090745	1
1	Shaft, Up/Down Sprocket	090748-1	1
2	Sprocket, 08B Z28	090664-1	1
3	Bolt, M8x20-5.8 Hex Head Full Thread Zinc	F81002-1	2
4	Nut, M8-8-B Hex Nylon Zinc Lock	F81032-2	2
5	Knob, 12992M10 Plastic Crank Handle	086338	1
6	Nut, M10-8-B Hex Nylon Zinc Lock	F81033-1	1

7	Guard, Up/Down Crank Sprocket Ptd	091834-1	1	
8	Bolt, M6x16 8.8 Hex Head Full Thread Zinc	F81001-15	2	
9	Washer, 6.4 Zinc Flat	F81053-1	2	
10	Bearing, 6203-2RS FLT Rolling	086114	2	
11	Guard, LT20 Up/Down Sprocket	090744-1	1	
12	Ring, Z 17 Outside Retaining	F81090-21	1	
13	<b>BOLT, M12 X 90-8.8 HEX HEAD ZINC</b>	F81004-2	2	
14	<b>WASHER, 13 ZINC FLAT</b>	F81056-1	4	
15	<b>NUT, M12-8 HEX NYLON ZINC LOCK</b>	F81034-2	2	
16	<b>BOX, RA-06/66/D1/S+N/V5 GEAR</b>	088577	1	
17	<b>SHAFT, LT20 UP/DOWN W/SPROCKET</b>	091298	1	
18	<b>KEY, A8 X 7 X 32 PARALLEL</b>	088564	2	
19	<b>RING, Z30 OUTSIDE RETAINING</b>	F81090-23	1	
20	<b>SPROCKET, 10B Z14 ZINC-PLATED</b>	090702-1	1	
21	<b>SCREW, M8 X 8-33H HEX SOCKET SET FLAT POINT ZINC</b>	F81014-1	1	
	<b>GUARD, LT20 UP/DOWN GEAR BOX SPROCKET COMPLETE</b>	096961	1	
22	Guard, LT20 Up/Down Gear Box Sprocket	096383-1	1	
23	Wiper, LT20 Up/Down Chain	096384	1	
24	Plate, LT20 Wiper Assy	096958-1	1	
25	Bolt, M6x16 8.8 Fe/Zn5 PN-M/82105	F81001-15	2	
26	Washer, M6 Split Lock Zinc	F81053-3	2	
27	<b>BOLT, M10 X 25-8.8 HEX HEAD FULL THREAD ZINC</b>	F81003-11	6	
28	<b>WASHER, 10.5 ZINC FLAT</b>	F81055-1	6	
29	<b>CHAIN, 08B-1-153 UP/DOWN</b>	091647	1	

### 5.4 Up/Down Chain Tensioner Assembly

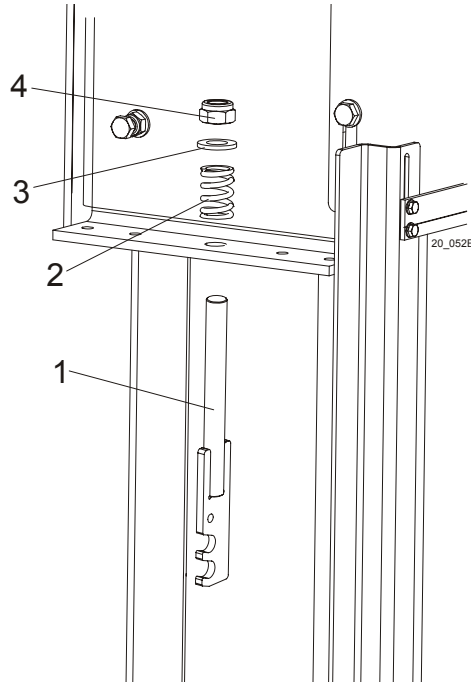

REF	DESCRIPTION (◆ Indicates Parts Available In Assemblies Only)	PART #	QTY.	
1	TENSIONER WELDMENT, LT20 UP/DOWN CHAIN ZINC-PLATED	090730-1	1	
2	SPRING, 14 X 30 X 3.2	090797	1	
3	WASHER, 13 ZINC FLAT	F81056-1	1	
4	NUT, M12-8 HEX NYLON ZINC LOCK	F81034-2	1	

## 5.5 Battery Box Assembly, DC Mills

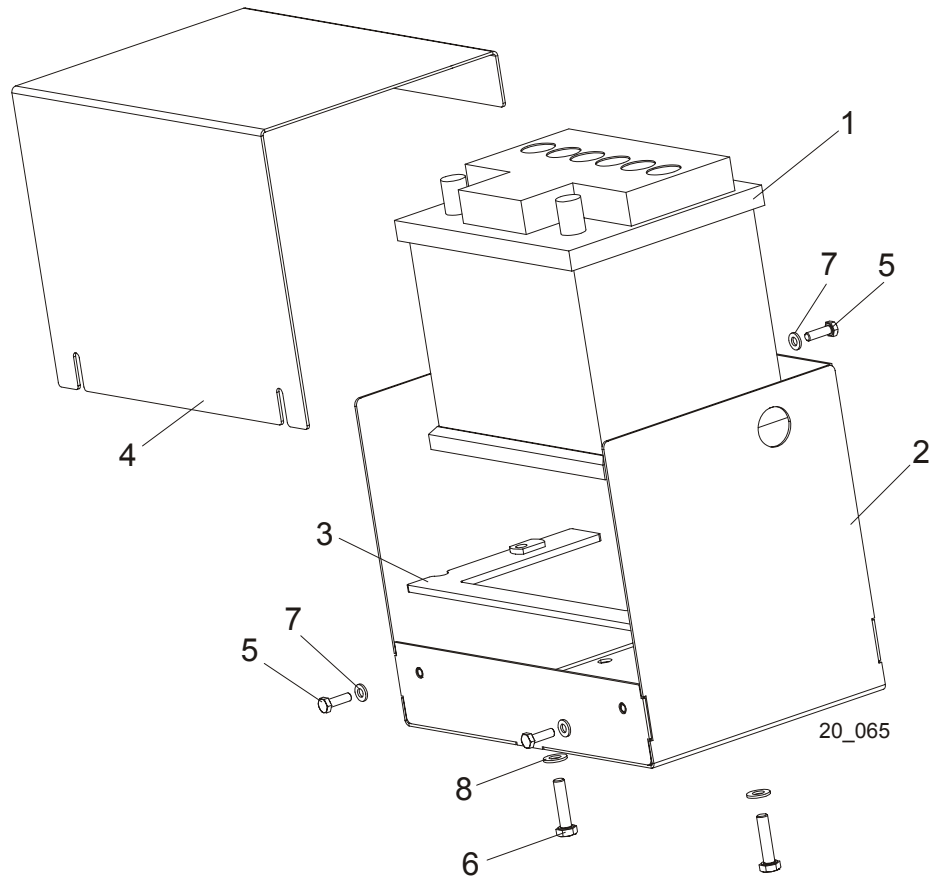

REF	DESCRIPTION (◆ Indicates Parts Available In Assemblies Only)	PART #	QTY.
	<b>BATTERY BOX, COMPLETE</b>	<b>091376</b>	<b>1</b>
1	Battery, 12V 50Ah	090999	1
2	<b>Box Weldment, Battery</b>	091377-1	1
3	<b>Bracket, Battery Hold-down Ptd</b>	091381-1	1
4	Lid, Battery Box Ptd	091382-1	1
5	Bolt, M6x20mm Hex Head Full Thread Zinc	F81001-2	3
6	Bolt, 8mm x 1.25 x 35mm HH Zinc	F81002-13	2
7	Washer, M6 Zinc Flat	F81053-1	3
8	Washer, M8 Zinc Flat	F81054-1	2

## SECTION 6 UP/DOWN ROLLERS & BLADE HEIGHT SCALE

### 6.1 Up/Down Rollers

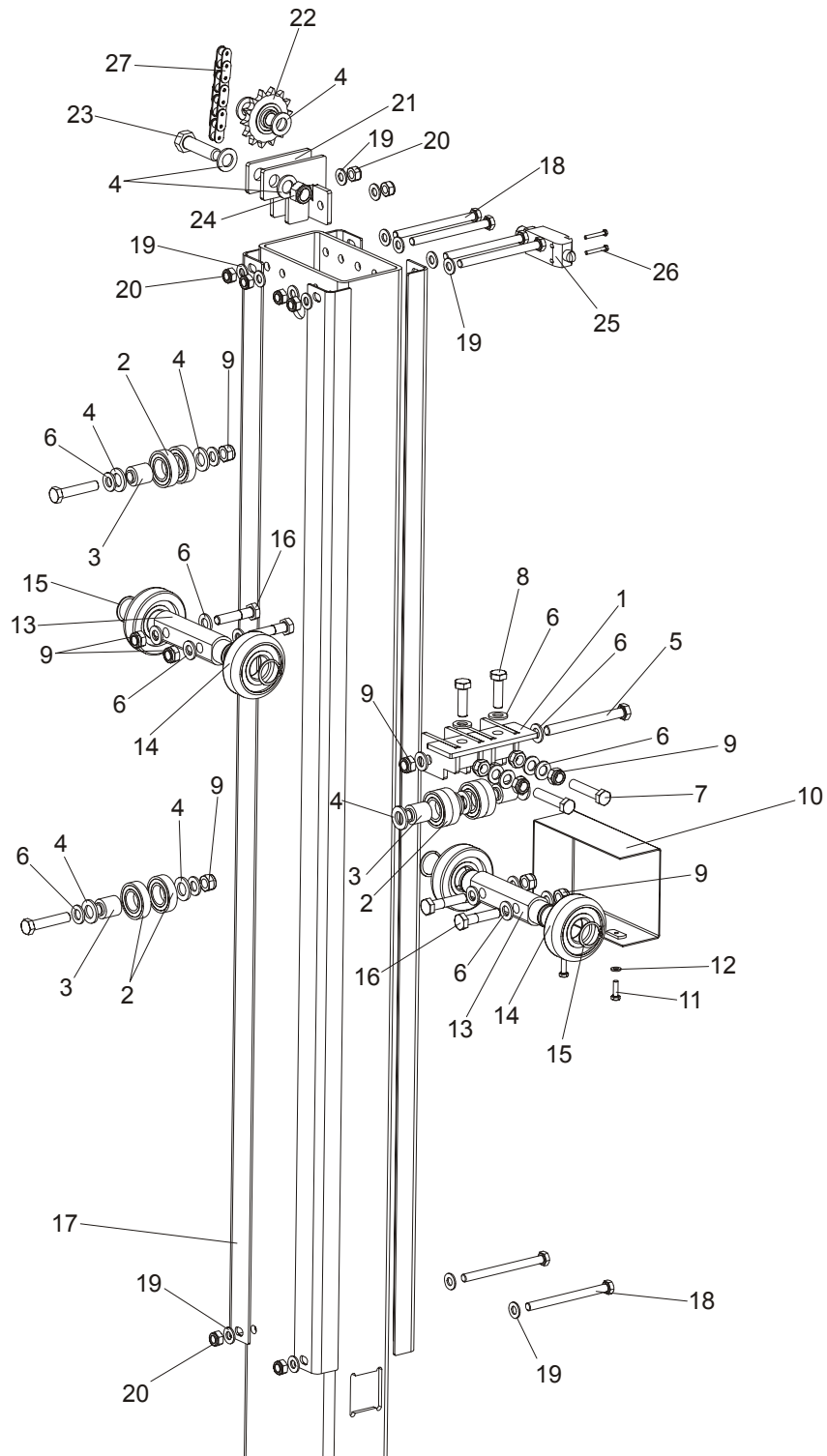

# Up/Down Rollers & Blade Height Scale

*Up/Down Rollers*

6

REF	DESCRIPTION (◆ Indicates Parts Available In Assemblies Only)	PART #	QTY.	
1	BRACKET WELDMENT, LT20 UP/DOWN ROLLER PTD	091095-1	1	
2	BEARING, 6005 2RS CX	089652	8	
3	BUSHING, LT20 UP/DOWN ROLLER	090790	4	
4	WASHER, 17 ZINC FLAT	F81058-1	12	
5	BOLT, M12 X 120 8.8 HEX HEAD ZINC	F81004-38	1	
6	WASHER, 13 ZINC FLAT	F81056-1	20	
7	BOLT, M12 X 60-8.8 HEX HEAD FULL THREAD ZINC	F81004-51	2	
8	BOLT, M12 X 40-8.8 HEX HEAD FULL THREAD ZINC	F81004-4	2	
9	NUT, M12-8 HEX NYLON ZINC LOCK	F81034-2	11	
10	GUARD, LT20 UP/DOWN ROLLERS PTD	091619-1	1	
11	BOLT, M6 X 20-8.8 HEX HEAD FULL THREAD ZINC	F81001-2	2	
12	WASHER, 6.4 ZINC FLAT	F81053-1	2	
13	SHAFT, UP/DOWN ROLLERS ZINC-PLATED	090616-1	2	
14	ROLLER, CBK-468	088433	4	
15	RING, Z30 SPRING RETAINING	F81090-23	4	
16	BOLT, M12 X 55-8.8 HEX HEAD FULL THREAD ZINC	F81004-43	4	
17	ANGLE, LT20 MAST TUBE	091182	4	
18	BOLT, M10 X 125-8.8 HEX HEAD ZINC	F81003-18	6	
19	WASHER, 10.5 ZINC FLAT	F81055-1	14	
20	NUT, M10-8-B HEX NYLON ZINC LOCK	F81033-1	8	
21	BRACKET WELDMENT, LT20 UP/DOWN SPROCKET PTD	091000	1	
22	SPROCKET, KSR 16.L0.10.10.14.08	088867	1	
23	BOLT, M16 X 60 8.8 HEX HEAD FULL THREAD ZINC	F81006-12	1	
24	NUT, M16-8 HEX NYLON ZINC LOCK	F81036-2	1	
25	SWITCH, EVN2000 C LIMIT	089816	1	
26	BOLT, M4 X 30 8.8 HEX HEAD FULL THREAD ZINC	F81011-5	2	
27	CHAIN, LT20 10B-1-197 TYPE UP/DOWN	091626	1	

## 6.2 Blade Height Scale

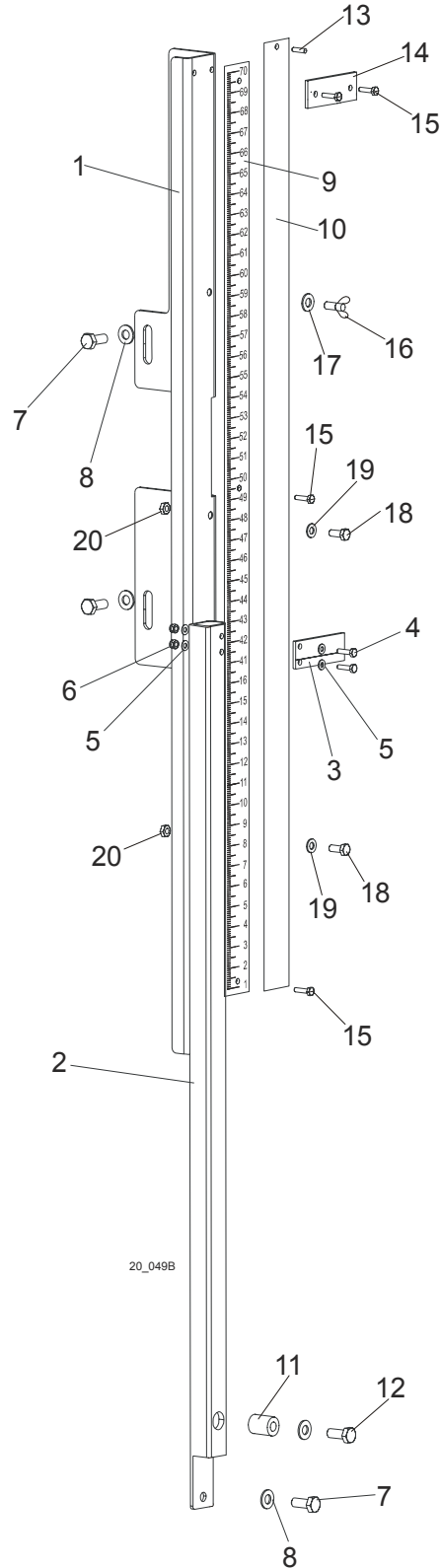



REF	DESCRIPTION (◆ Indicates Parts Available In Assemblies Only)	PART #	QTY.	
1	BRACKET, SCALE MOUNT PTD	092749-1	1	
2	BRACKET, SCALE INDICATOR MOUNT PTD	092751-1	1	
3	INDICATOR, BLADE HEIGHT SCALE	094821	1	
4	BOLT, M4 X 16 5.8 HEX HEAD FULL THREAD ZINC	F81011-6	2	
5	WASHER, 4.3 ZINC FLAT	F81051-2	4	
6	NUT, M4-B HEX NYLON ZINC LOCK	F81029-1	2	
7	BOLT, M8 X 20-5.8 HEX HEAD FULL THREAD ZINC	F81002-1	4	
8	WASHER, 8.4 ZINC FLAT	F81054-1	4	
9	BAR, SCALE	092750	1	
	DECAL, LT20 0-80CM METRIC SCALE	091239	1	
10	BAR, INCH SCALE	093133	1	
	DECAL, 45-63CM METRIC	P12040-2	1	
	DECAL, METRIC 16-40MM	P12040-1	1	
11	BUSHING, SPACER	092008-1	1	
12	BOLT, M8 X 45 - 8.8 Fe/Zn5, PN-M/82105	F81002-14	1	
13	PIN, 3x20 ROLL ZINC	F81044-5	1	
14	BAR, SCALE MOUNT	093134	1	
15	SCREW, M6x20- 4.8-B Fe/Zn5 PN-85/M-82207	F81001-31	1	
16	BOLT, M6X16 BN276	F81001-16	1	
17	WASHER, FLAT ZINC	F81053-11	1	
18	BOLT, M6X20MM, HH, FULL THREAD, ZINC	F81001-2	2	
19	WASHER, M6, FLAT,ZINC	F81053-1	2	
20	NUT, M6, HEX,NYLON LOCK ZINC	F81031-2	2	

## SECTION 7 POWER FEED & TRACK ROLLERS

### 7.1 Power Feed Assembly, AC Mills

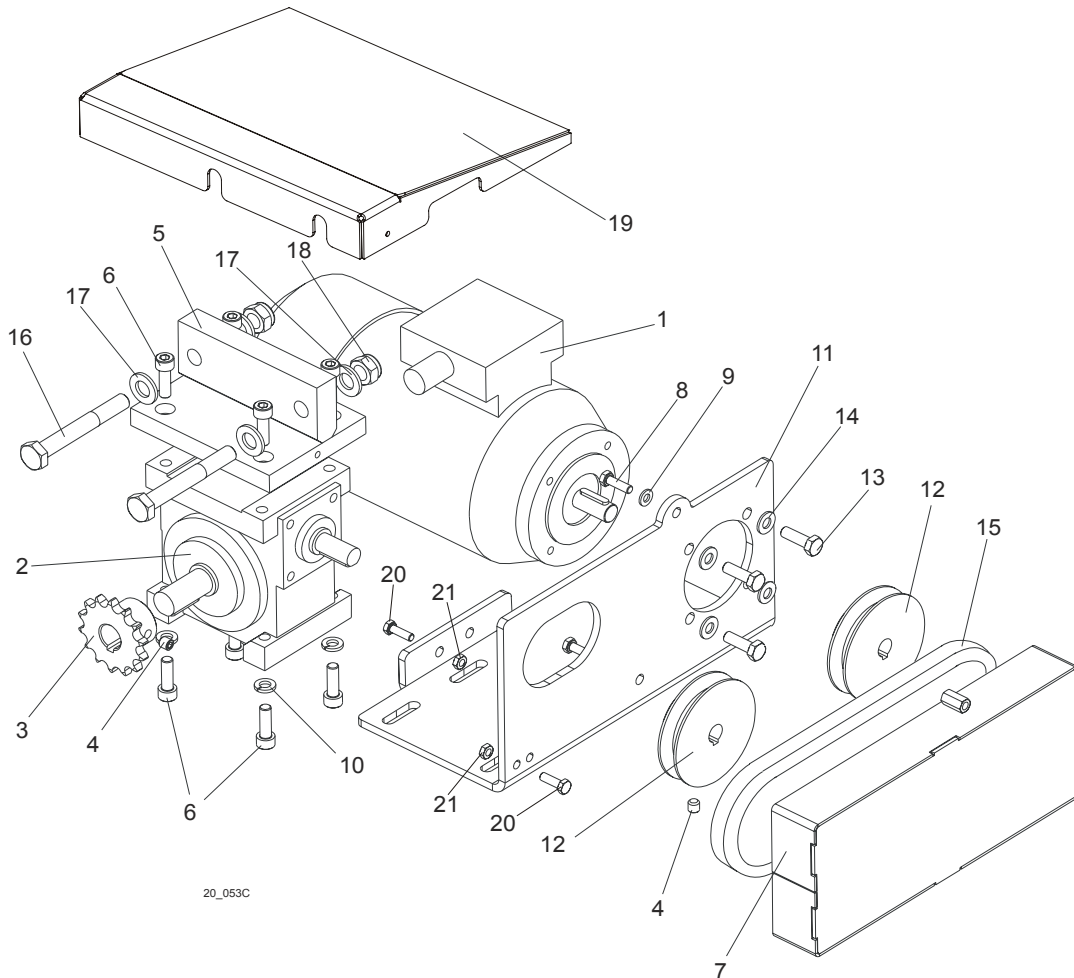

REF	DESCRIPTION (◆ Indicates Parts Available In Assemblies Only)	PART #	QTY.
	<b>POWER FEED ASSEMBLY, LT20 AC</b>	091196	1
1	Motor, SKh71X-4C2 RAL 9005	091186	1
2	Gear Box, RA-04/7.5/D1/N+S/B8 w/Output Shaft	090698	1
3	Sprocket, 10B Z14 Zinc-plated	090702-1	1
4	Screw, M8x8-33H Hex Socket Set Flat Point Zinc	F81014-1	1
5	Bracket, Power Feed Gear Box Mount	090715-1	1
6	Screw, M8X25-8.8 Hex Socket Head Cap Zinc	F81002-21	4
7	Guard, Power Feed Drive Belt	091195-1	1
8	Bolt, M6x20-8.8 Hex Head Full Thread Zinc	F81001-2	2
9	Washer, 6.4 Zinc Flat	F81053-1	2
10	Washer, 8.2 Split Lock Zinc	F81054-4	4
11	Bracket, Power Feed Gear Box	091191	1
12	Pulley, LT20 Power Feed Gear Box Ptd	090699-1	2

13	Bolt, M8x25-8.8-B Hex Head Full Thread Zinc	F81002-5	4	
14	Washer, 8.4 Zinc Flat	F81054-1	4	
15	V-Belt, HA-560 (STOMIL-SANOK)	088562	1	
16	<b>BOLT, M12X90-8.8 HEX HEAD ZINC</b>	F81004-2	2	
17	<b>WASHER, 13 ZINC FLAT</b>	F81056-1	4	
18	<b>NUT, M12-8 HEX NYLON ZINC LOCK</b>	F81034-2	2	
19	<b>GUARD, POWER FEED MOTOR</b>	093780-1	1	
20	<b>BOLT, M8 x 25mm HEX HEAD GR 5.8 ZINC</b>	F81002-5	2	
21	<b>NUT, M8 HEXAGON, GRADE 5.8 FREE ZINC</b>	F81032-1	2	

**7.2 Power Feed Assembly, DC Mills**

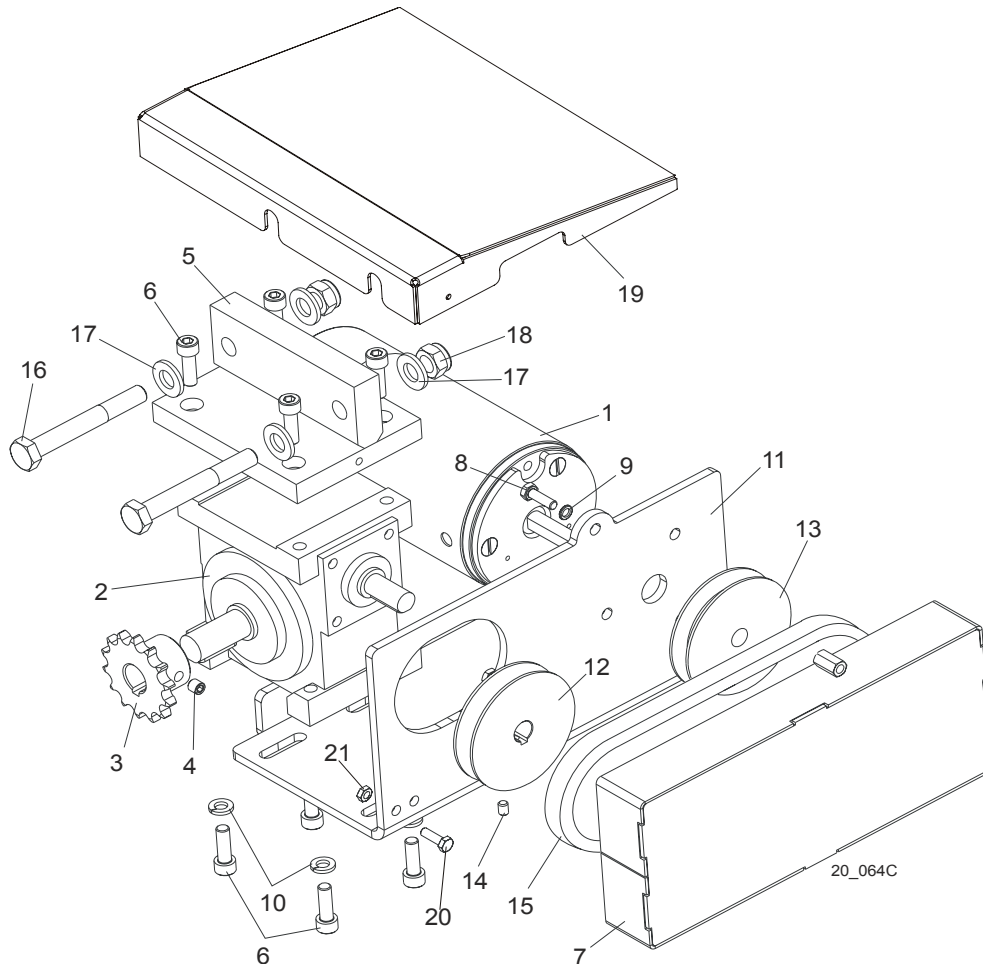

REF	DESCRIPTION (◆ Indicates Parts Available In Assemblies Only)	PART #	QTY.
	<b>POWER FEED ASSEMBLY, LT20 DC</b>	090703	1
1	Motor, 12V 0.5HP	P04140	1
2	Gear Box, RA-04/7.5/D1/N+S/B8 w/Output Shaft	090698	1
3	Sprocket, 10B Z14 Zinc-plated	090702-1	1
4	Screw, M8x8-33H Hex Socket Set Flat Point Zinc	F81014-1	1
5	Bracket, Power Feed Gear Box Mount	090715-1	1
6	Screw, M8X25-8.8 Hex Socket Head Cap Zinc	F81002-21	4
7	Guard, Power Feed Drive Belt	091195-1	1
8	Bolt, M6x20-8.8 Hex Head Full Thread Zinc	F81001-2	2
9	Washer, 6.4 Zinc Flat	F81053-1	2
10	Washer, 8.2 Split Lock Zinc	F81054-4	4
11	Bracket, LT20 Power Feed Motor Mount Ptd	090701-1	1
12	Pulley, LT20 Power Feed Gear Box Ptd	090699-1	2
13	Sheave, Up/Down Motor "A" 82/12.7 Ptd	093158-1	1
14	Screw, M6x8 Hex Socket Set Cone Point Zinc	F81013-1	1

15	V-Belt, HA-560 (STOMIL-SANOK)	088562	1	
16	<b>BOLT, M12X90-8.8 HEX HEAD ZINC</b>	F81004-2	2	
17	<b>WASHER, 13 ZINC FLAT</b>	F81056-1	4	
18	<b>NUT, M12-8 HEX NYLON ZINC LOCK</b>	F81034-2	2	
19	<b>GUARD, POWER FEED MOTOR</b>	093780-1	1	
20	<b>BOLT, M8 x 25mm HEX HEAD GR 5.8 ZINC</b>	F81002-5	2	
21	<b>NUT, M8 HEXAGON, GRADE 5.8 FREE ZINC</b>	F81032-1	2	

### 7.3 Upper Track Rollers And Wipers

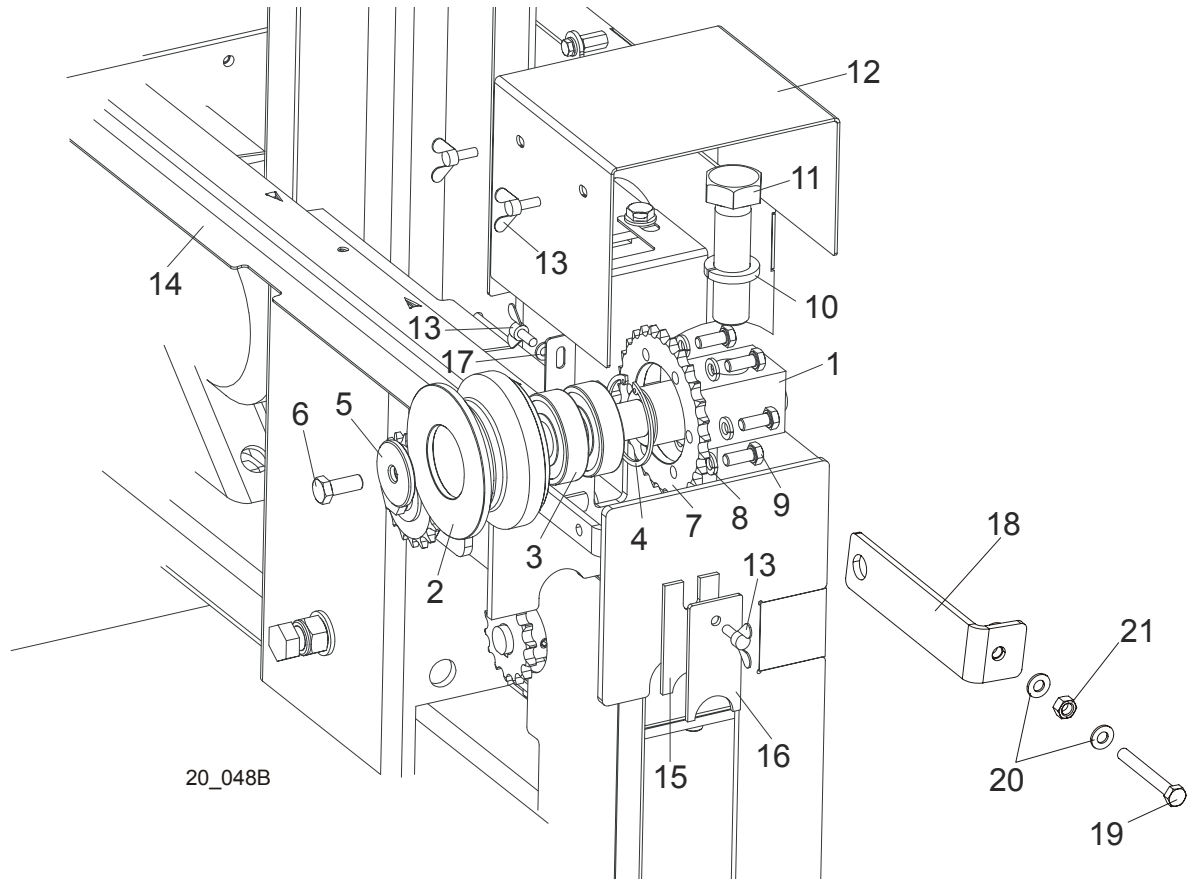

REF	DESCRIPTION (◆ Indicates Parts Available In Assemblies Only)	PART #	QTY.	
	<b>ROLLER ASSEMBLY, LT20 UPPER TRACK</b>	090662	2	
1	Block, Upper Track Roller Mount	090665	1	
2	Roller, Upper Track	090663	1	
3	Bearing, 6305 2RS NSK	P08066	2	
4	Ring, 2 7/16" Bevelled Snap	F04254-21	1	
5	Washer, Drive Wheel	086286	1	
6	Bolt, M10x25-8.8 Hex Head Full Thread Zinc	F81003-11	1	
7	Sprocket, O8B Z28	090664	2	
8	Washer, 8.2 Split Lock Zinc	F81054-4	6	
9	Bolt, M8x20-5.8 Hex Head Full Thread Zinc	F81002-1	6	
10	<b>WASHER, Z 24.5 SPLIT LOCK ZINC</b>	F81061-4	2	
11	<b>BOLT, M24X2X90-8.8 HEX HEAD FULL THREAD ZINC</b>	F81009-2	2	
12	<b>GUARD, UPPER TRACK ROLLER</b>	090749-1	2	
13	<b>SCREW, M6 X 16 BN276 DIN 316 THUMB</b>	F81001-16	8	
14	<b>COVER, MIDDLE TRACK</b>	091656	1	
15	<b>WIPER, TOP RAIL</b>	M04113	2	
16	<b>PLATE, TRACK WIPER PTD</b>	088559-1	2	
17	<b>WASHER, 6.4 ZINC FLAT</b>	F81053-1	2	

18	TENSIONER, POWER FEET SPROCKET	092862-1	1	
19	BOLT, M8 X 65MM,HH,GRADE 5.8, ZINC	F81002-3	1	
20	WASHER, M8, FLAT,ZINC	F81054-1	2	
21	NUT, M8 HEXAGON,GRADE 5.8 FREE ZINC	F81032-1	1	

# 7 Power Feed & Track Rollers

## Lower Track Rollers

### 7.4 Lower Track Rollers

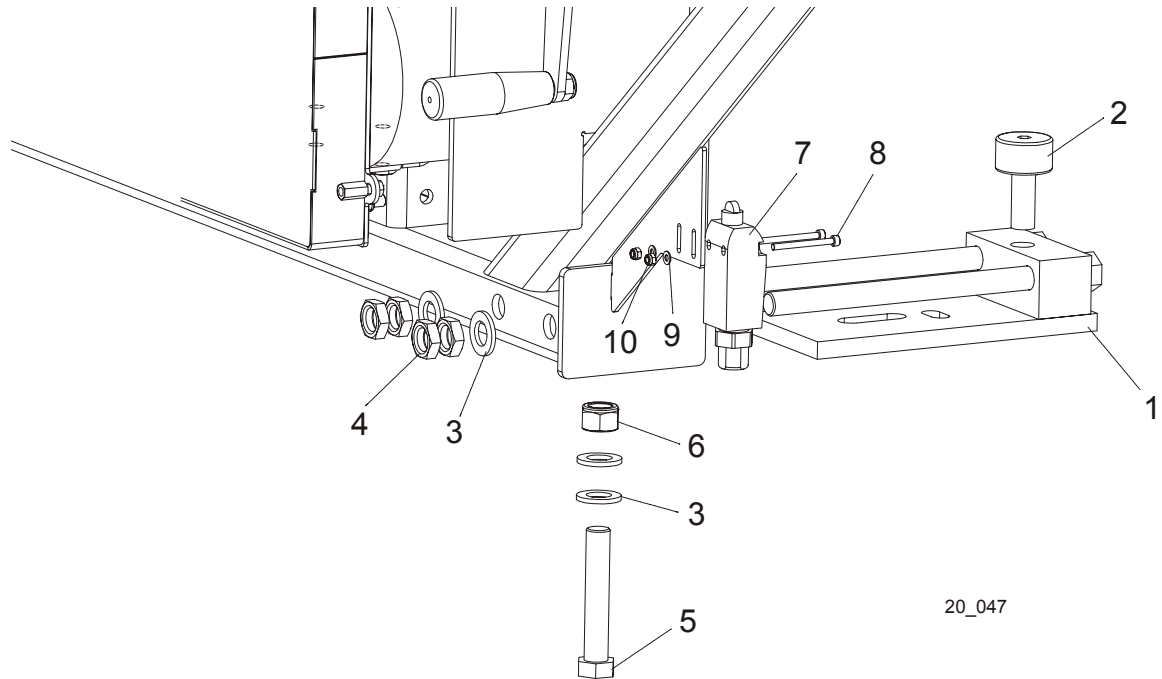

20\_047

REF	DESCRIPTION (◆ Indicates Parts Available In Assemblies Only)	PART #	QTY.	
	<b>ROLLER ASSEMBLY, LT20 LOWER TRACK</b>	090670	2	
1	Bracket, LT20 Lower Track Roller	090671-1	1	
2	Bearing, Cam Follower (McGill)	012797	1	
3	<b>WASHER, 17 ZINC FLAT</b>	F81058-1	4	
4	<b>NUT, M16 HEX THIN ZINC</b>	F81036-4	4	
5	<b>BOLT, M16 X 90-8.8 HEX HEAD ZINC</b>	F81006-17	1	
6	<b>NUT, M16-8 HEX NYLON ZINC LOCK</b>	F81036-2	1	
7	<b>SWITCH, EVN2000 A LIMIT</b>	091742	1	
8	<b>SCREW, M4 X 45-8.8 HEX SOCKET HEAD CAP ZINC</b>	F81011-33	2	
9	<b>NUT, M4-B HEX NYLON ZINC LOCK</b>	F81029-1	2	
10	<b>WASHER, 4.3 ZINC FLAT</b>	F81051-2	2	



## SECTION 8 BED FRAME ASSEMBLY

### 8.1 Bed Rail Assembly, Front And Rear (S/M type frame)

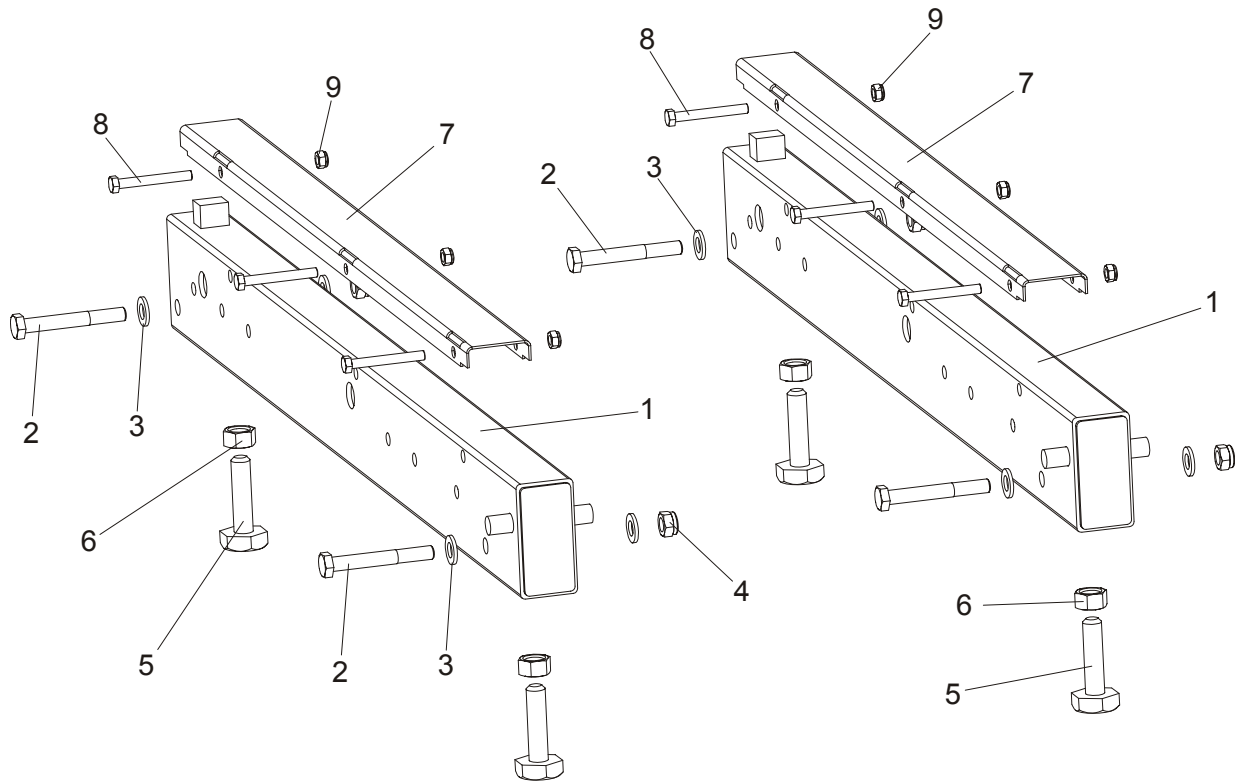

REF	DESCRIPTION (◆ Indicates Parts Available In Assemblies Only)	PART #	QTY.
1	<b>BED RAIL ASSEMBLY, REAR PAINTED</b>	091555	2
2	Bolt, M12 x 90-8.8 Hex Head	F81004-2	4
3	Washer, 13 SAE FLAT	F81056-1	8
4	Nut, m12-8 hex Nylon Lock	F81034-2	4
5	Bolt, M16, Bed Rail Adjustment	086809	4
6	Nut, M16-5-B Zinc Hex Head	F81036-5	4
7	<b>COVER, STAINLESS STEEL BED RAIL</b>	S09944	2
8	<b>BOLT, M8X65-5,8 ZINC HEX HEAD</b>	F81002-3	6
9	<b>NUT, M8-8-B-ZINC HEX NYLON LOCK</b>	F81032-2	6

# 8

## Bed Frame Assembly

### Bed Rail Assembly, Front Middle (S/M type frame)

#### 8.2 Bed Rail Assembly, Front Middle (S/M type frame)

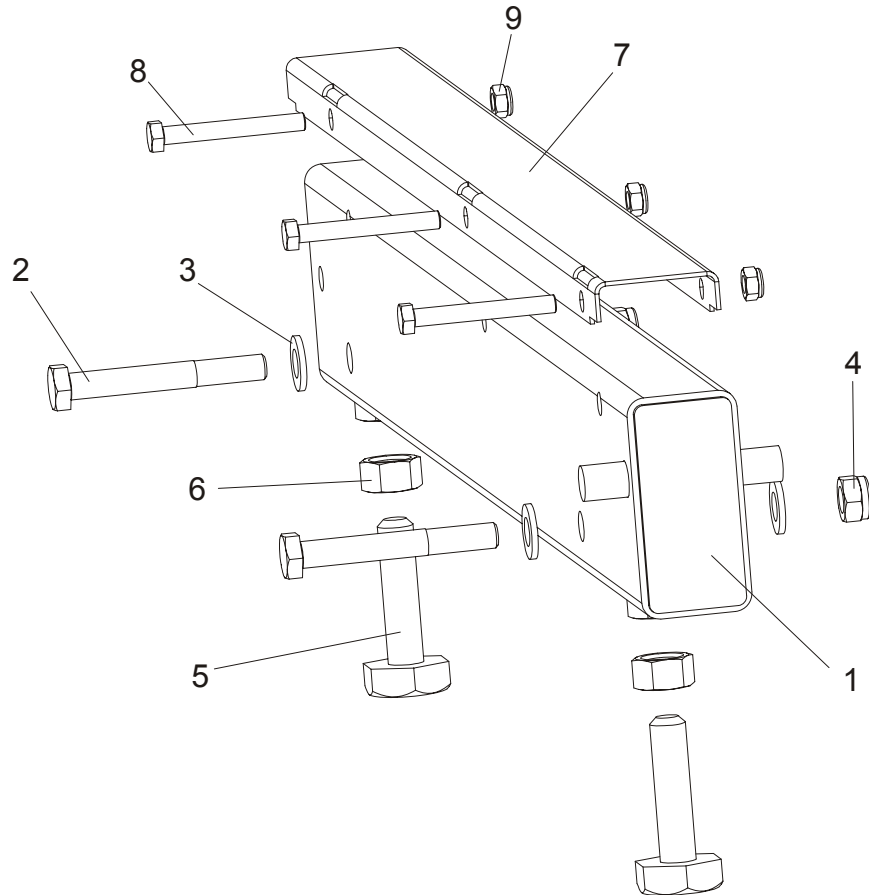

REF	DESCRIPTION (◆ Indicates Parts Available In Assemblies Only)	PART #	QTY.
1	<b>BED RAIL ASSEMBLY, FRONT MIDDLE</b>	091556	1
2	Bolt, M12 x 90-8.8 Hex Head	F81004-2	2
3	Washer, 13 SAE Flat	F81056-1	4
4	Nut, M12-8 hex Nylon Lock	F81034-2	2
5	Bolt, M16, Bed Rail Adjustment	086809	2
6	Nut, M16-5-B Zinc Hex Head	F81036-5	2
7	<b>COVER, STAINLESS STEEL BED RAIL</b>	S09944	2
8	<b>BOLT, M8X65-5,8 ZINC HEX HEAD</b>	F81002-3	3
9	<b>NUT, M8-8-B-ZINC HEX NYLON LOCK</b>	F81032-2	3

### 8.3 Bed Rail Assembly, Rear Middle (S/M type frame)

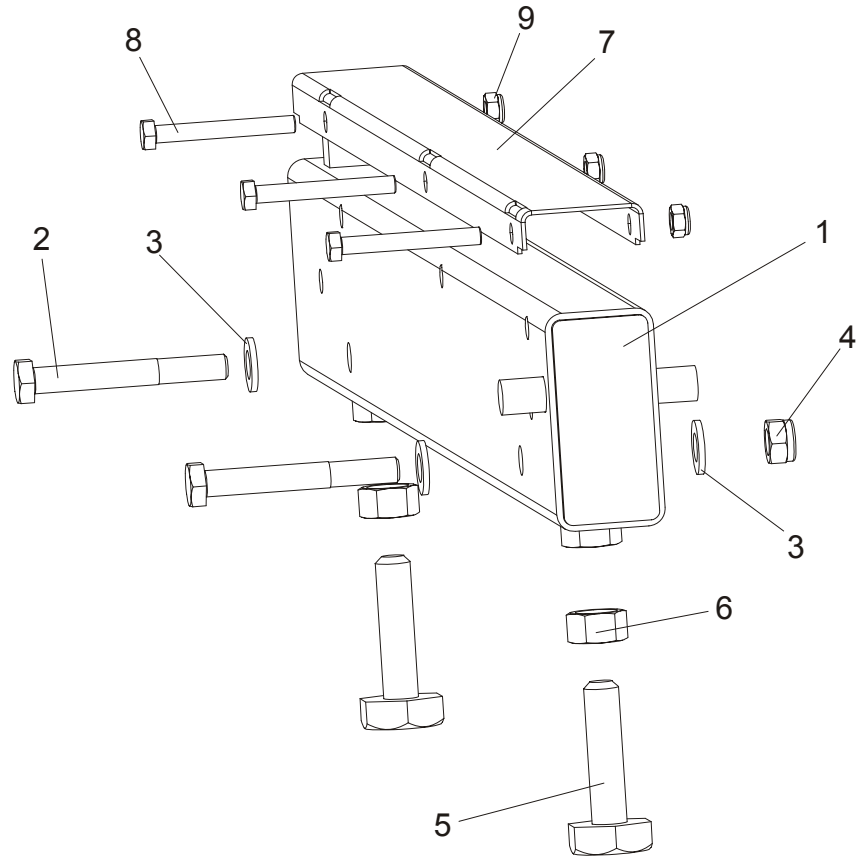

REF	DESCRIPTION (◆ Indicates Parts Available In Assemblies Only)	PART #	QTY.
1	<b>BED RAIL ASSEMBLY, REAR MIDDLE PAINTED</b>	091557	1
2	Bolt, M12 x 90-8.8 Hex Head	F81004-2	2
3	Washer, 13 SAE Flat	F81056-1	4
4	Nut, M12-8 hex Nylon Lock	F81034-2	2
5	Bolt, M16, Bed Rail Adjustment	086809	2
6	Nut, M16-5-B Zinc Hex Head	F81036-5	2
7	<b>COVER, STAINLESS STEEL BED RAIL</b>	S09944	2
8	<b>BOLT, M8X65-5,8 ZINC HEX HEAD</b>	F81002-3	3
9	<b>NUT, M8-8-B-ZINC HEX NYLON LOCK</b>	F81032-2	3

# 8 Bed Frame Assembly

## Bed Rail Assembly (L type frame)

### 8.4 Bed Rail Assembly (L type frame)

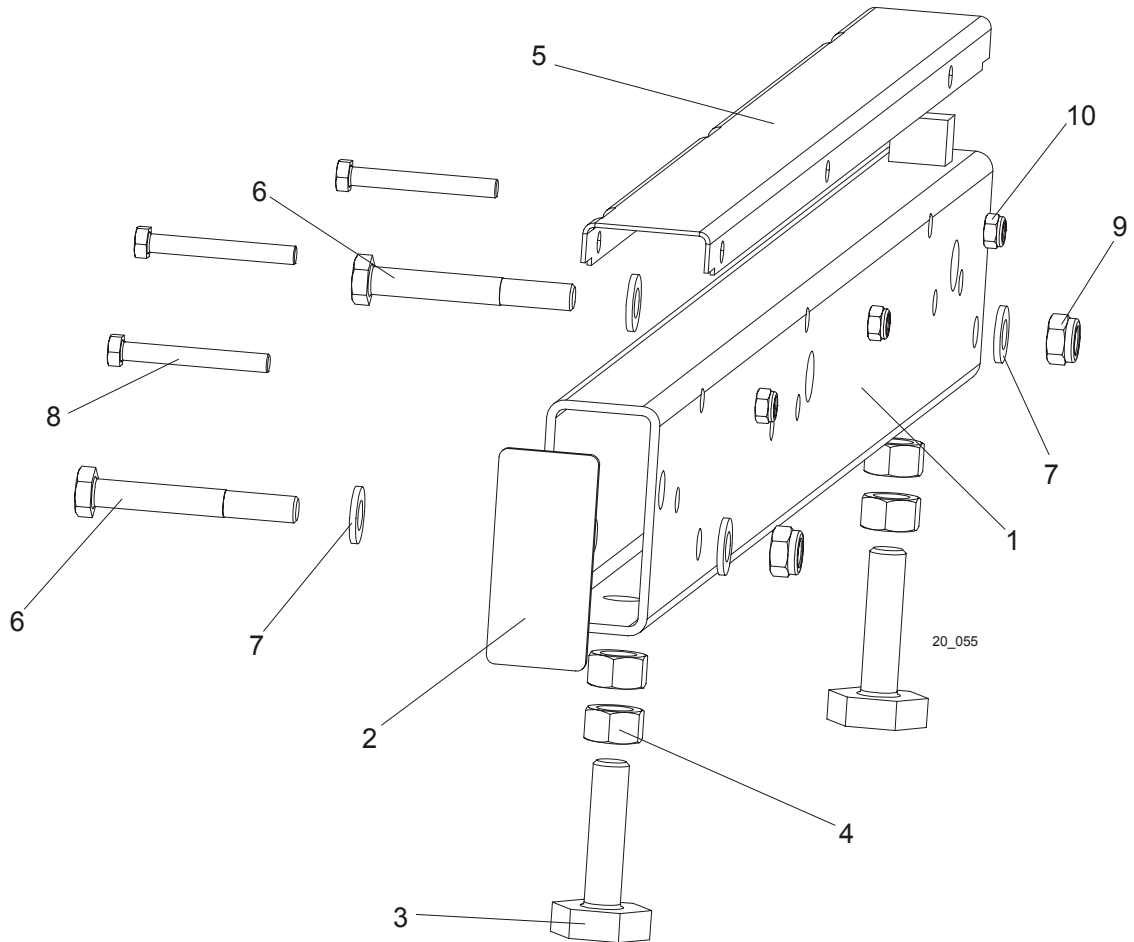

REF	DESCRIPTION (◆ Indicates Parts Available In Assemblies Only)	PART #	QTY.
	<b>LONG BED RAIL ASSEMBLY</b>	089385	1
1	Bed Rail Tube, Long	087433	1
2	Plate, Bed Rail End Cap	087853	1
3	Bolt, Bed Rail Adjustment	S13006	2
4	Nut, 5/8-11 Hex	F05010-54	4
5	Cover, Stainless Steel Bed Rail	S09944	1
6	Bolt, M12 x 90-8.8 Hex Head Zinc	F81004-2	2
7	Washer, 13 Zinc Flat	F81056-1	4
8	<b>Bolt, M8x65-5.8 Hex Head Zinc</b>	F81002-3	3
9	Nut, M12-8 Hex Nylon Zinc Lock	F81034-2	2
10	Nut, M8-8-B Hex Nylon Zinc Lock	F81032-2	3

### 8.5 Bed Rail Assembly (L type frame)

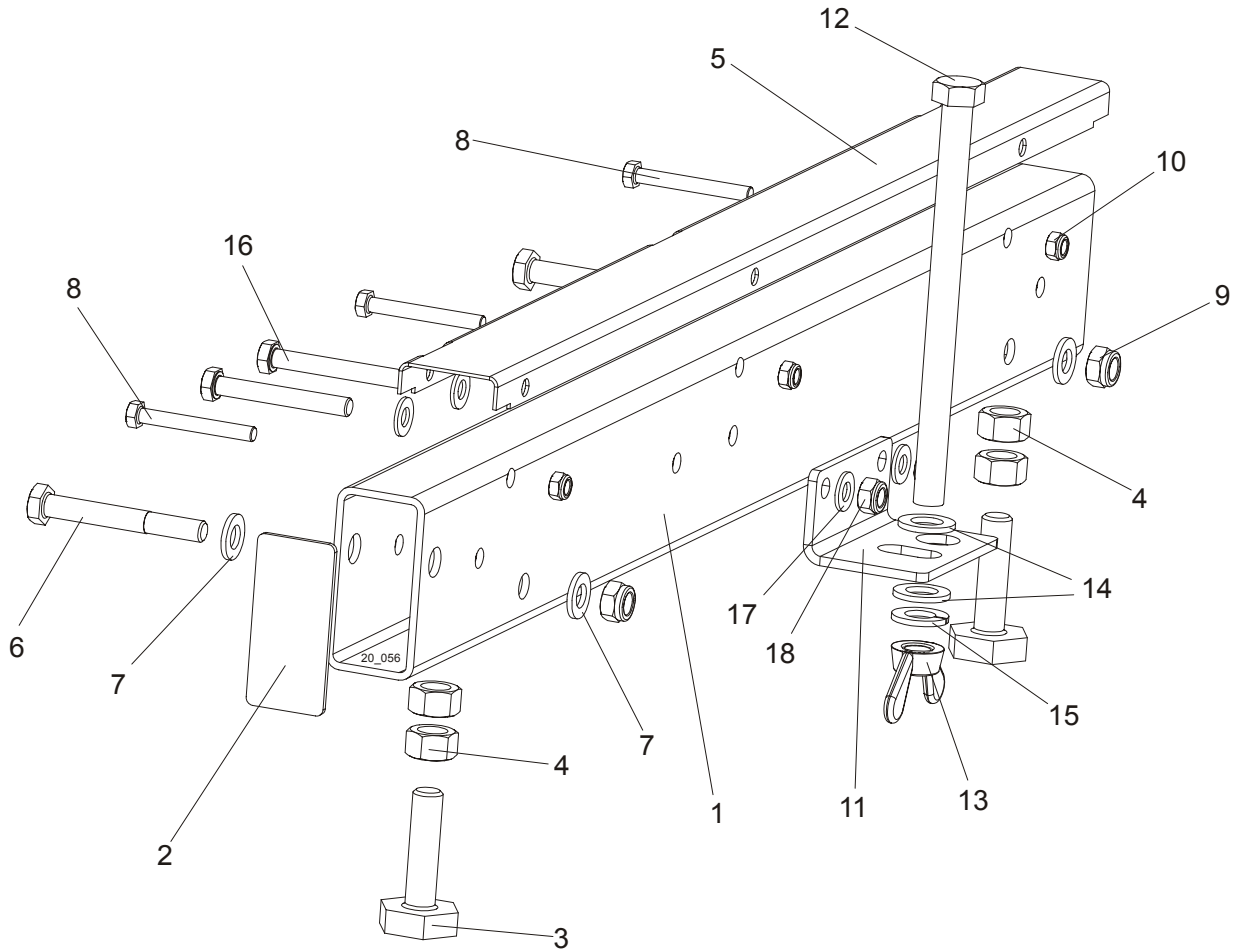

REF	DESCRIPTION (◆ Indicates Parts Available In Assemblies Only)	PART #	QTY.
	<b>BED RAIL ASSEMBLY, SHORT</b>	089386	1
1	Bed Rail Tube, Short	087878	1
2	Plate, Bed Rail End Cap	087853	1
3	Bolt, Bed Rail Adjustment	S13006	2
4	Nut, 5/8-11 Hex	F05010-54	4
5	Cover, Bed Rail Stainless Steel	S09944	1
6	Bolt, M12x90-8.8 Hex Head Zinc	F81004-2	2
7	Washer, 13 Zinc Flat	F81056-1	4
8	<b>Bolt, M8x65-5.8 Hex Head Zinc</b>	F81002-3	3
9	Nut, M12-8 Hex Nylon Zinc Lock	F81034-2	2
10	Nut, M8-8-B Hex Nylon Zinc Lock	F81032-2	3
11	Bracket, Loading Arms Link Storage	090258-1	1
12	Bolt, M16x220-8.8-B Hex Head Zinc	F81006-21	1
13	Nut, M16-8 Hex Nylon Zinc Lock	F81036-2	1
14	Washer, 17 Zinc Flat	F81058-1	2
15	Washer, 16.3 Split Lock Zinc	F81058-2	1

**8****Bed Frame Assembly***Bed Rail Assembly (L type frame)*

---

<b>16</b>	Bolt, M10x75-8.8 Hex Head Zinc	F81003-15	2	
<b>17</b>	<b>Washer, 10.5 Zinc Flat</b>	F81055-1	2	
<b>18</b>	Nut, M10-8-B Hex Nylon Zinc Lock	F81033-1	2	

## 8.6 Stationary Leg

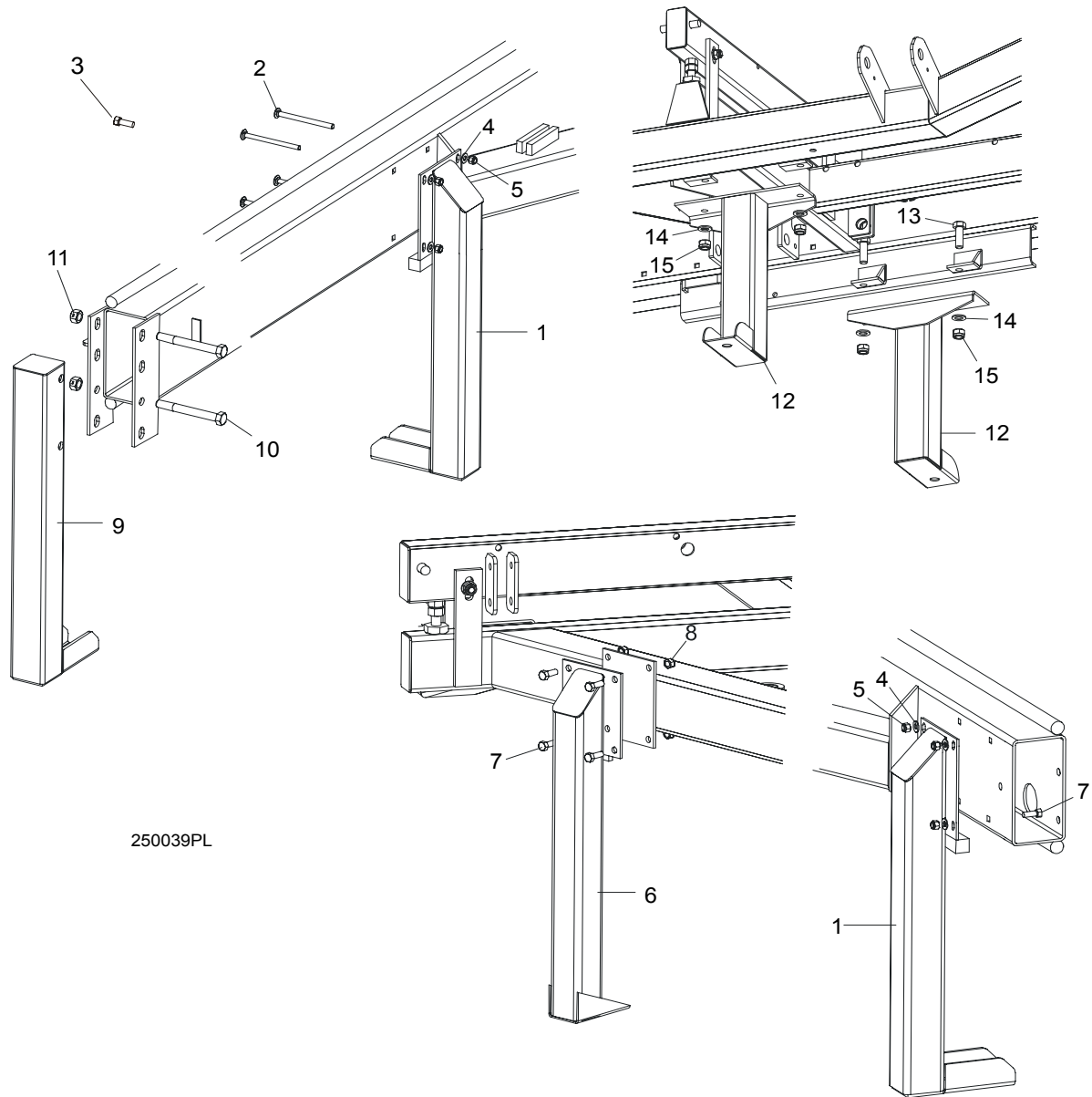

250039PL

REF	DESCRIPTION (◆ Indicates Parts Available In Assemblies Only)	PART #	QTY.
1	LEG, LONG STATIONARY	087451-1	2/3
2	BOLT, M10 X 120 - 8.8 CARRIAGE HEAD ZINC	F81003-33	8
3	BOLT, 3/8-16 X 1" HEX HEAD ZINC GRADE 8	F05007-7	4
4	WASHER, 10.5 ZINC FLAT	F81055-1	16
5	NUT, M10-8-B HEX NYLON ZINC LOCK	F81033-1	8/12
6	LEG, SHORT STATIONARY	087450-1	2
7	BOLT, M10 X 25-8.8 HEX HEAD ZINC	F81003-11	12
8	NUT, M10-8-B HEX NYLON ZINC LOCK	F81033-1	12
9	LEG, FRONT STATIONARY	087452-1	1

**8****Bed Frame Assembly***Stationary Leg*

---

10	BOLT, M16 X 140 - 8.8 HEX HEAD	F81006-4	2	
11	NUT, 5/8-11 HEX ZINC	F05010-4	2	
12	LEG, MIDDLE STATIONARY	087093-1	2	
13	BOLT, M16 X 50-8.8 HEX HEAD FULL THREAD ZINC	F81006-7	4	
14	WASHER, 17 ZINC FLAT	F81058-1	4	
15	NUT, M16-8 HEX NYLON ZINC LOCK	F81036-2	4	



### 8.7 Pivot Bed Rail Assembly

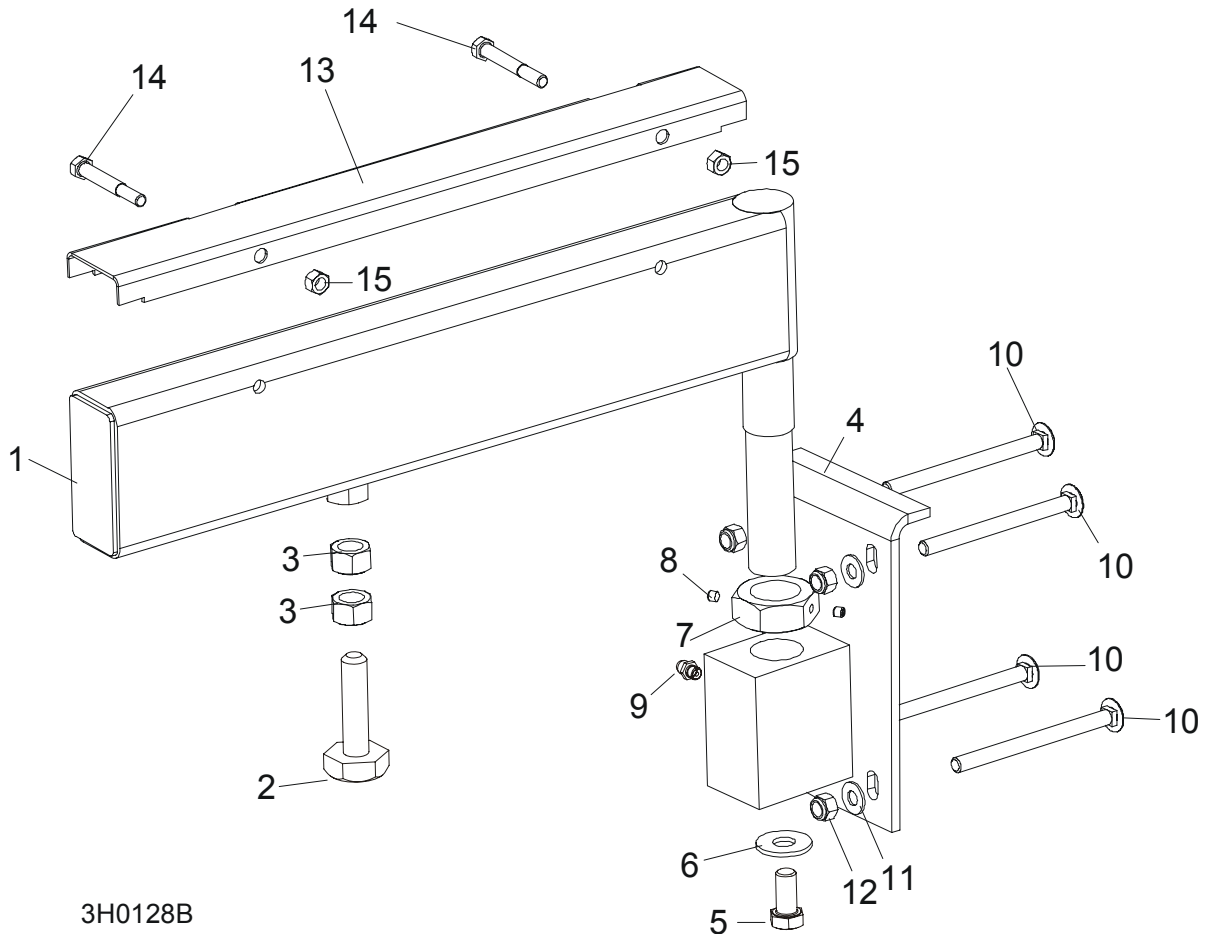

3H0128B

REF	DESCRIPTION (◆ Indicates Parts Available In Assemblies Only)	PART #	QTY.
	<b>PIVOT BED RAIL, COMPLETE</b>	087829	2
	<b>PIVOT BED RAIL, COMPLETE</b>	087855	2
1	Rail Weldment, Pivot Bed	087852-1	1
	Rail, Pivot Bed	087848-1	1
	Bolt Assembly, Bed Rail Adjustment		
2	Bolt, Pivot Bed Rail Adjustment	086809	1
3	Nut, M16-5.8 Zinc Hex	F81036-1	2
4	Bracket, Pivot Bed Rail Mounting	087841-1	1
5	Bolt, M12x25-8.8 Hex Head Full Thread Zinc	F81004-31	1
6	Washer, 9/16" Zinc Flat	F05011-52	1
7	Nut, M16-5.8 Zinc Hex Nut, M32 Zinc Hex Thin	F81036-1 F81039-2	1
8	Screw, 1/4-28 x 1/4 Socket Head Brass Tip Set	F05005-42	2
9	Fitting, M6 Grease	086280	1
10	<b>BOLT, M10 X 120 8.8 CARRIAGE HEAD ZINC</b>	F81003-33	2
11	<b>BOLT, M10 X 120 8.8 CARRIAGE HEAD ZINC</b>	F81003-33	6
12	<b>WASHER, 10.5 ZINC FLAT</b>	F81055-1	8

## 8

**Bed Frame Assembly***Pivot Bed Rail Assembly*

<b>13</b>	<b>NUT, M16-8 HEX NYLON ZINC LOCK</b>	F81036-2	8	
	<b>COVER KIT, PIVOT BED RAIL</b>	015926	2	
	<b>COVER KIT, PIVOT BED RAIL</b>	N/A	2	
<b>14</b>	Cover, Pivot Bed Rail Stainless Steel	012994	1	
	Cover, Pivot Bed Rail	S13012	1	
<b>15</b>	Bolt, M8x65-5.8 Hex Head Zinc	F81002-3	2	
<b>16</b>	Nut, M8-8-B Hex Nylon Zinc Lock	F81032-2	2	
	<b>WRENCH, BED RAIL ADJUSTMENT (<a href="#">Patrz rozdział 8.4</a>)</b>	015970	1	

## 8.8 Log Side Support Assembly

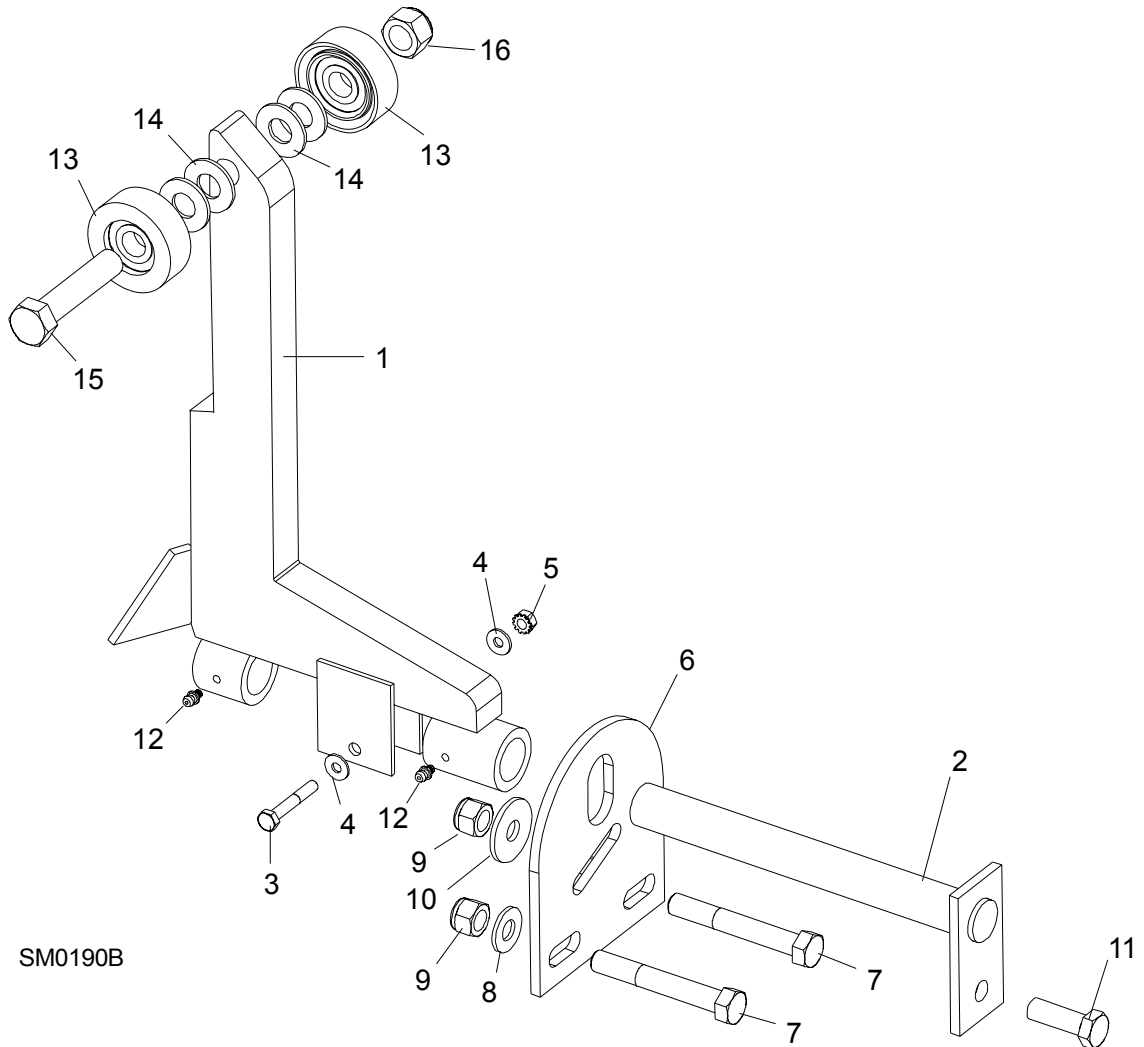

REF	DESCRIPTION (◆ Indicates Parts Available In Assemblies Only)	PART #	QTY.
	<b>SUPPORT, LOG SIDE</b>	092686	1
<b>1</b>	<b>MOUNTING KIT, LOG SIDE SUPPORT</b>	085538-1	3
<b>2</b>	Pin, Log Side Support Pivot	091549-1	1
<b>3</b>	Bolt, M8x45 - 8.8 Hex Head Grade 5	F81002-14	1
<b>4</b>	Washer, 8.4 Flat	F81054-1	2
<b>5</b>	Nut, M8-8-B Self Locking	F81032-2	1
<b>6</b>	Plate, Log Side Support End	091591-1	1
<b>7</b>	Bolt, M12 x 75-8.8 Hex Head	F81004-21	2
<b>8</b>	Washer, 13 Flat	F81056-1	2
<b>9</b>	Nut, M12-8 Hex Nylon Lock	F81034-2	3
<b>10</b>	Washer, 15 Flat Special Zinc-Plated	F81057-3	1
<b>11</b>	Bolt, M12 x 35-8.8 Hex Head	F81004-24	1

## 8

**Bed Frame Assembly***Log Side Support Assembly*

---

12	<b>FITTING, 3/16" GREASE</b>	P04107	2	
13	Roller Assembly, Side Support	015014-1	2	
14	Washer, 17 Flat	F81058-1	2	
15	Bolt, M16x65-8.8-B Hex Head Grade 5	F81006-1	1	
16	Nut, M16-8 Nylon Lock	F81036-2	1	
	Instruction Sheet, Side Support Roller	015109-526	1	

### 8.9 Tie Down Chain Assembly

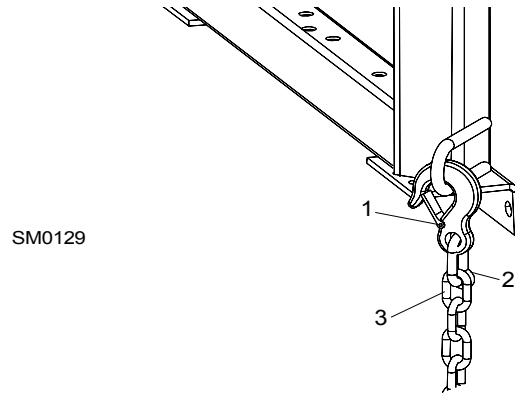

REF	DESCRIPTION (◆ Indicates Parts Available In Assemblies Only)	PART #	QTY.	
	<b>TIE DOWN CHAIN ASSEMBLY</b>	A04376	1	
1	Hook, 5/8" Safety Chain	P12075	1	◆
2	Cold Shut, 3/8" Plain	P04772-2	1	◆
3	Chain, N-10 x 35 Plain Link	R80558	.28 m	◆

### 8.10 Bed Frame Decals

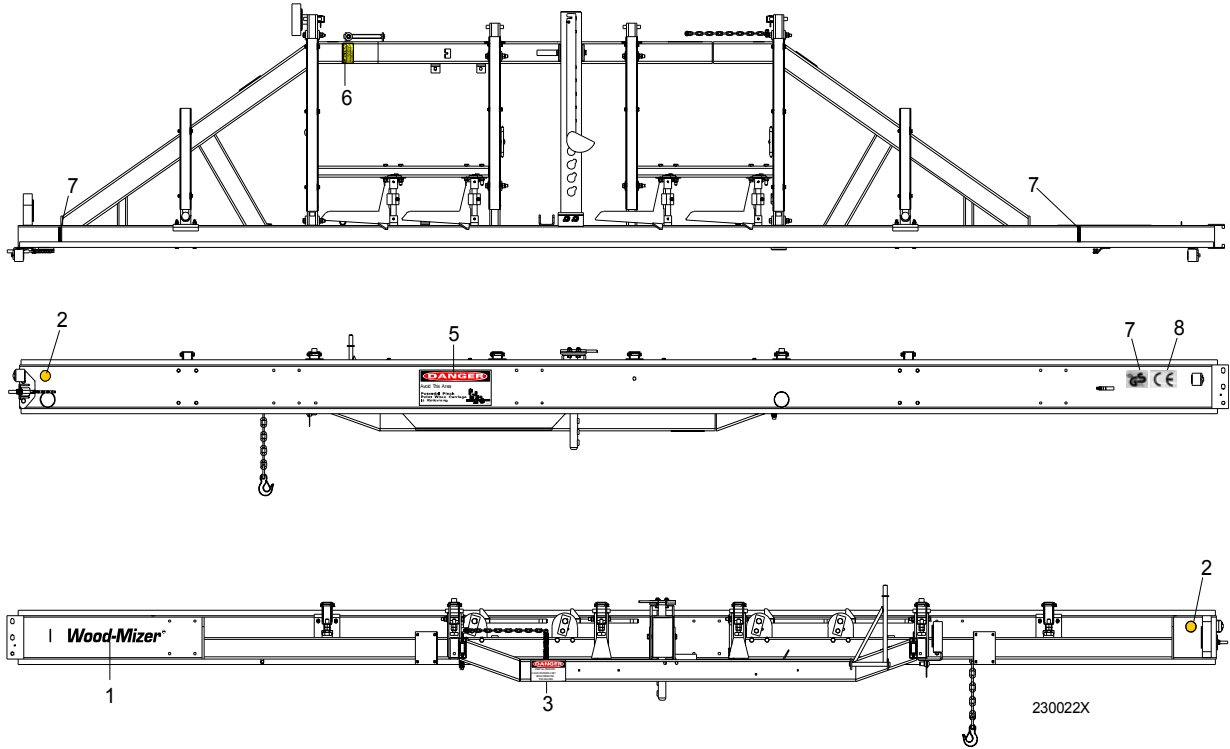

REF	DESCRIPTION (◆ Indicates Parts Available In Assemblies Only)	PART #	QTY.
4	DECAL, AMBER REFLECTIVE 2" ROUND	P07453	2
5	DECAL, KEEP AWAY DANGER	S09851	1
6	DECAL, PINCH POINT DANGER	P10287	1
7	DECAL, SAW HEAD REST CAUTION	S12581	1
8	DECAL, LOG LENGTH LIMIT	S12051	2
9	DECAL, GS SAFETY CERTIFICATION SMALL	P85072	1
10	DECAL, CE CERTIFIED SAWMILL SMALL	P85070	1

## SECTION 9 LOG CLAMP, TURNER, LOADER & TOE BOARDS

### 9.1 Manual Log Clamp

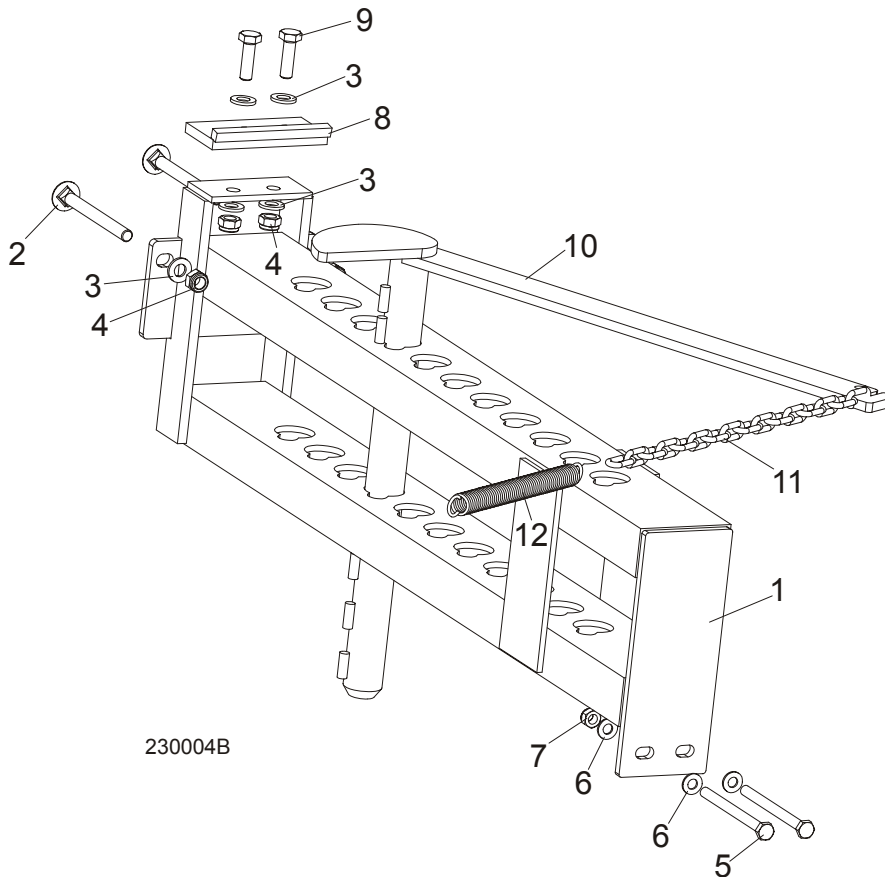

REF	DESCRIPTION (◆ Indicates Parts Available In Assemblies Only)	PART #	QTY.
	<b>MANUAL LOG CLAMP</b>	092683	1
1	Bracket, Manual Log Clamp	092677-1	1
2	Bolt, M12x130-8.8 Carriage Head Zinc	F81004-26	2
3	Washer, 13 Flat Zinc	F81056-1	6
4	Nut, M12-8 Hex Nylon Zinc Lock	F81034-2	4
5	Bolt, M10x125-8.8 Hex Head Zinc	F81003-18	2
6	Washer, 10.5 Flat Zinc	F81055-1	4
7	Nut, M10-8-B Hex Nylon Zinc Lock	F81033-1	2
8	Stop Weldment, Log Clamp Painted	086980-1	1
9	Bolt, M12 x 40-8.8 Hex Head Full Thread Zinc	F81004-4	2
10	Log Clamp Weldment, Manual Painted	W09412	1
11	Chain, Log Clamp	M04311	1
12	Spring, FI 2.8 X FI 22.2 X 183	091864	1

**9.2 Log Clamp Assembly**

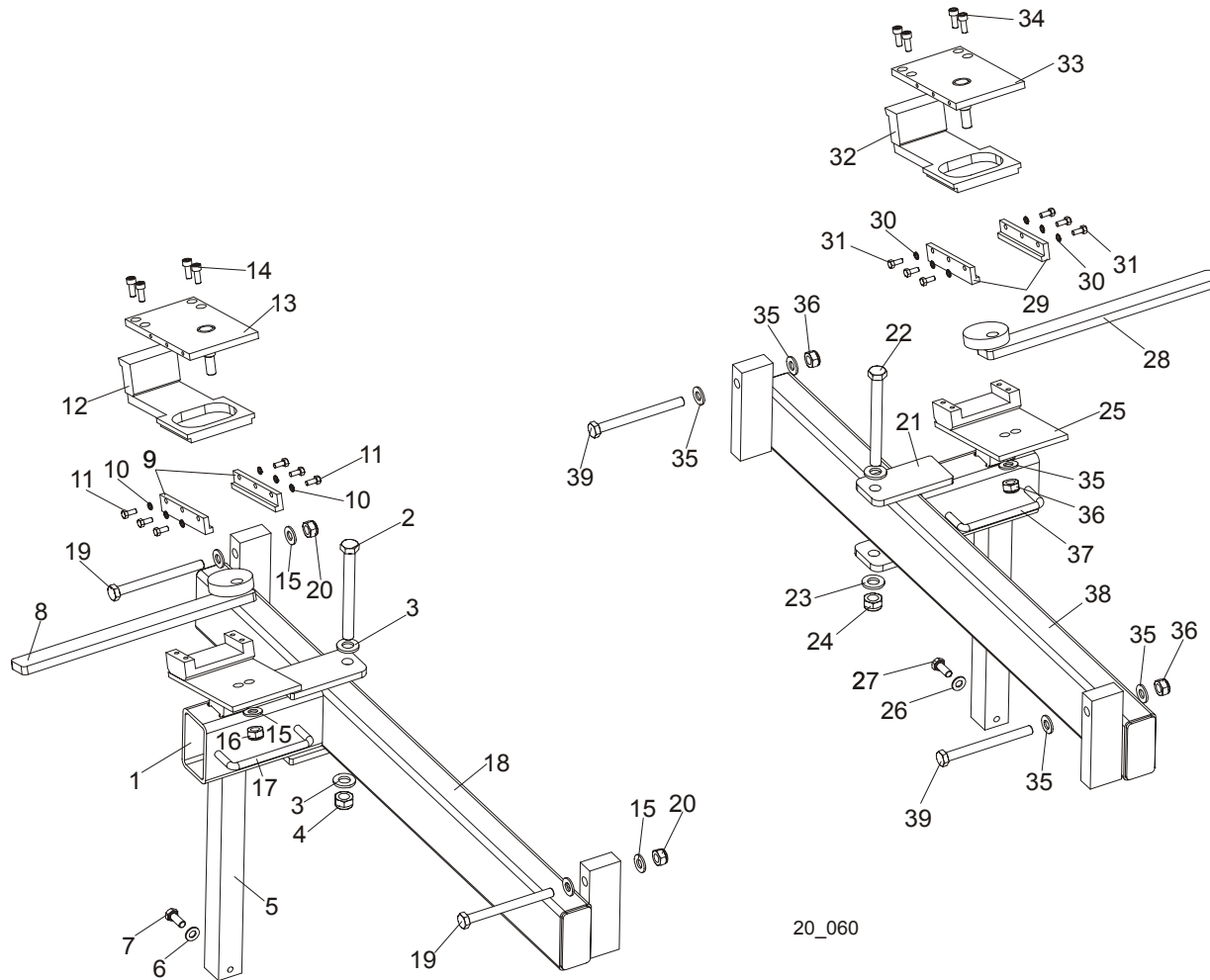

20\_060

REF	DESCRIPTION (◆ Indicates Parts Available In Assemblies Only)	PART #	QTY.
	<b>LOG CLAMP ASSEMBLY, LEFT (LT50/80 NON-HYDRAULIC)</b>	089631 <sup>1</sup>	1
1	Arm Weldment, Log Clamp Zinc-plated	089624-1	1
2	Bolt, M12x120 8.8 Hex Head Zinc	F81004-38	1
3	Washer, 13 Zinc Flat	F81056-1	2
4	Nut, M12-8 Hex Nylon Zinc Lock	F81034-2	1
5	Mount Weldment, Log Clamp Zinc-plated	090174-1	1
6	Washer, 8.4 Zinc Flat	F81054-1	4
7	Bolt, M8x20-8.8-B Hex Head Full Thread Zinc	F81002-4	2
8	Lever, Log Clamp Zinc-plated	089611-1	1
9	Plate, Log Clamp Side Zinc-plated	089615-1	2
10	Washer, 5.1 Split Lock Zinc	F81052-2	6
11	Bolt, M5x12-5.8 Hex Head Full Thread Zinc	F81000-5	6
12	Plate, Clamping Zinc-plated	090202-1	1
13	Plate, Log Clamp Upper Zinc-plated	089614-1	1



14	Screw, M6x16-8.8 Hex Socket Set Cap Zinc	F81001-21	4	
15	Washer, 10.5 Zinc Flat	F81055-1	5	
16	Nut, M8-8-B Hex Nylon Zinc Lock	F81032-2	1	
17	Handle, 4" w/Bolts	P08065	1	
18	Bar Weldment, Log Clamp Guide Ptd	089628-1	1	
19	Bolt, M10x110 8.8 Hex Head Zinc	F81003-43	2	
20	Nut, M10-8-B Hex Nylon Zinc Lock	F81033-1	2	
	<b>LOG CLAMP ASSEMBLY, RIGHT (NON-HYDRAULIC)</b>	090349	1	
21	Arm Weldment, Log Clamp Zinc-plated	089624-1	1	
22	Bolt, M12x120 8.8 Hex Head Zinc	F81004-38	1	
23	Washer, 13 Zinc Flat	F81056-1	2	
24	Nut, M12-8 Hex Nylon Zinc Lock	F81034-2	1	
25	Mount Weldment, Log Clamp Zinc-plated	090174-1	1	
26	Washer, 8.4 Zinc Flat	F81054-1	2	
27	Bolt, M8x20-8.8-B Hex Head Full Thread Zinc	F81002-4	2	
28	Lever, Log Clamp Zinc-plated	090348-1	1	
29	Plate, Log Clamp Side Zinc-plated	089615-1	2	
30	Washer, 5.1 Split Lock Zinc	F81052-2	6	
31	Bolt, M5x12-5.8 Hex Head Full Thread Zinc	F81000-5	6	
32	Plate, Clamping Zinc-plated	090202-1	1	
33	Plate, Log Clamp Upper Zinc-plated	090347-1	1	
34	Screw, M6x16-8.8 Hex Socket Head Cap Zinc	F81001-21	4	
35	Washer, 10.5 Zinc Flat	F81055-1	5	
36	Nut, M10-8-B Hex Nylon Zinc Lock	F81033-1	3	
37	Handle, 4" w/Bolts	P08065	1	
38	Bar Weldment, Log Clamp Guide Ptd	089628-1	1	
39	Bolt, M10x110 8.8 Hex Head Zinc	F81003-43	2	

<sup>1</sup> The number of clamps depends on the frame length.

### 9.3 Manual Log Turner

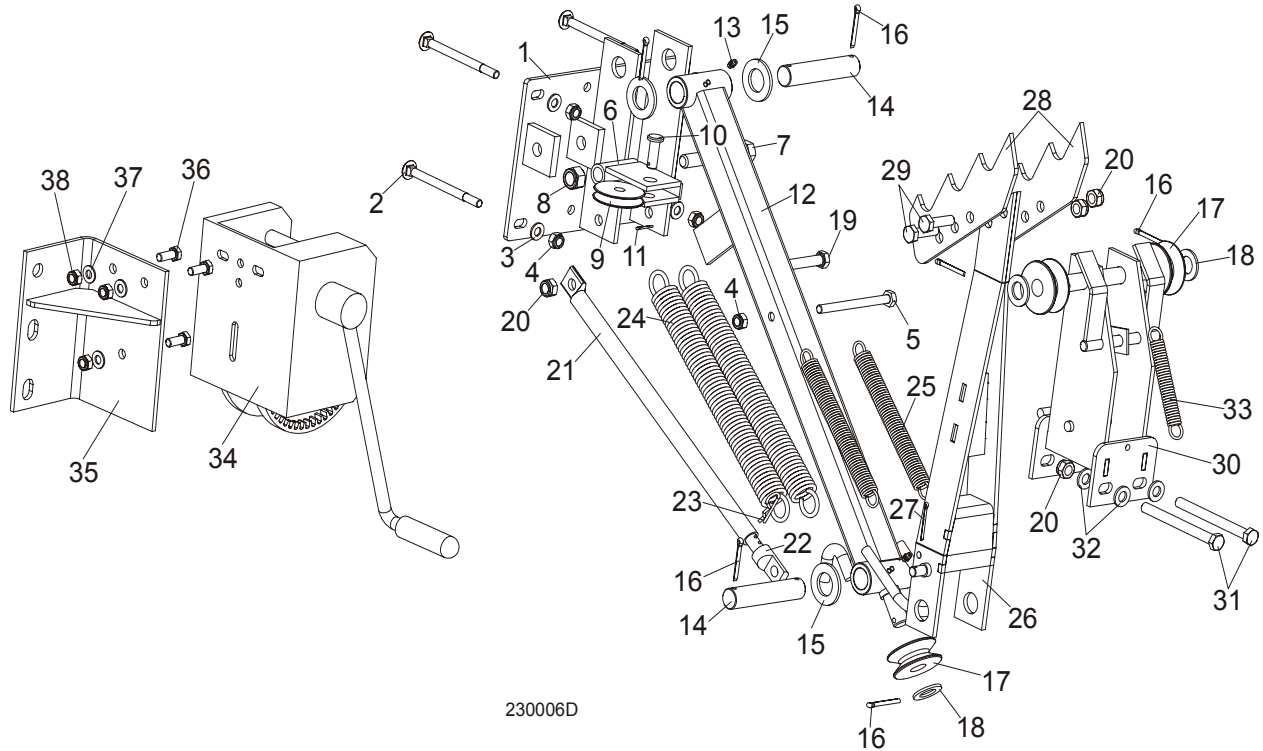

230006D

REF	DESCRIPTION (◆ Indicates Parts Available In Assemblies Only)	PART #	QTY.
	<b>MANUAL LOG TURNER OPTION (S/M TYPE FRAME)</b>	091291	1
	<b>MANUAL LOG TURNER OPTION (L TYPE FRAME)</b>	091562	1
1	Bracket Weldment, Manual Log Turner Painted (S/M Type Frame)	091269-1	1
	Bracket Weldment, Manual Log Turner Painted (L Type Frame)	090271-1	1
2	Bolt, M10x120 8.8 Carriage Head Zinc	F81003-33	4
3	Washer, 10.5 Flat Zinc	F81055-1	4
4	Nut, M10-8-B Hex Nylon Zinc Lock	F81033-1	5
5	Bolt, M10x115-8.8 Hex Head Zinc	F81003-19	1
6	Bracket Weldment, Cable Guide Pulley Painted	091295-1	1
7	Bolt, M16x100-8.8 Hex Head Full Thread Zinc	F81006-2	1
8	Nut, M16-8 Hex Nylon Zinc Lock	F81036-2	1
9	Pulley, Zinc-Plated Cable Guide	091273-1	1
10	Pin, 12x35 B Clevis Zinc	F81049-1	1
11	Pin, 2.5x20 Cotter Zinc	F81043-1	1
12	Arm Weldment, Manual Turner Lower Painted	091256-1	1
13	Fitting, M6 Grease	086280	2
14	Pin, Manual Turner Arm Pivot Zinc-Plated	091275-1	2
15	Washer, 28 Flat Zinc	F81061-1	4
16	Pin, 5x40 Cotter Zinc	F81043-31	7

17	Pulley, Manual Turner Zinc-Plated	091280-1	3	
18	Washer, 20.5 Split Lock Zinc	F81059-1	5	
19	Bolt, M12x120 8.8 Hex Head Zinc	F81004-38	1	
20	Nut, M12-8 Hex Nylon Zinc Lock	F81034-2	5	
21	Tube, Manual Turner Painted	091537-1	1	
22	Rod Weldment, Manual Turner Painted	091540-1	1	
23	Pin, 1/8x1 13/16 Safety	P05059	1	
24	Spring, FI 4.5 x FI 35 x 303	091863	2	◆
25	Spring, FI 2.8 x FI 22.2 x183	091864	2	
26	Arm Weldment, Manual Turner Upper Painted	091263-1	1	
27	Pin, 4x25 Cotter Zinc	F81043-2	1	
28	Claw, Log Turner Painted	088082-1	2	
29	Bolt, M12x40-8.8 Hex Head Full Thread Zinc	F81004-4	2	
30	Bracket Weldment, Manual Turner Pulley Painted	091281-1	1	
31	Bolt, M12x130-8.8 Hex Head Zinc	F81004-36	2	
32	Washer, 13 Flat Zinc	F81056-1	4	
33	Spring, FI 1.9 X FI 14.2 X 104	091865	1	
34	<b>WINCH, AL-KO TYPE 901</b>	096453	1	
35	<b>BRACKET, WINCH MOUNT (COMP. NON-HYD FRAME)</b>	085841-1	1	
36	<b>BOLT, M10-1.5X25MM HH GR8.8</b>	F81003-11	3	
37	<b>WASHER, FLAT, M10, ZINC</b>	F81055-1	3	
38	<b>NUT, M10, NYLON HEX ZINC LOCK</b>	F81033-1	3	

### 9.4 Manual Toe Board

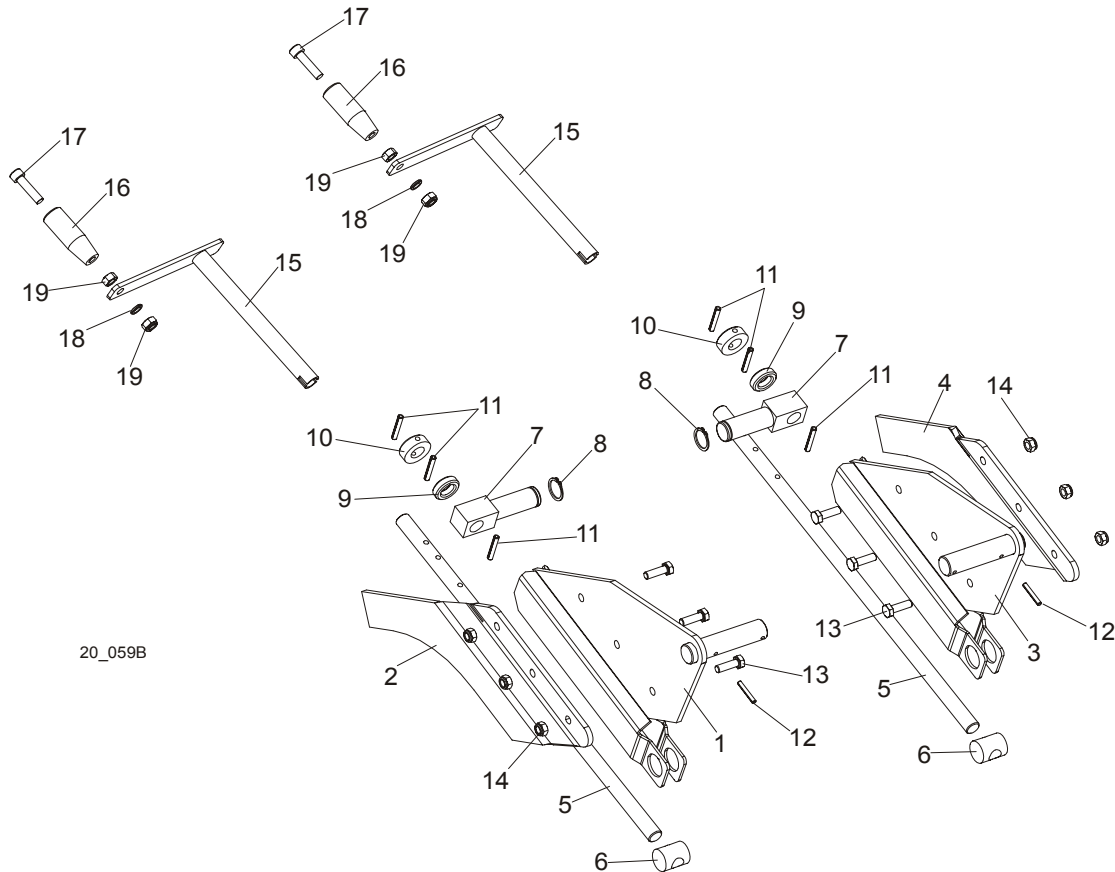

20\_059B

REF	DESCRIPTION (◆ Indicates Parts Available In Assemblies Only)	PART #	QTY.
	<b>TOE BOARD KIT, MANUAL FRONT</b>	094929	1
1	Plate Weldment, Manual Toe Board Front	094927-1	1
2	Extension, Manual Toe Board Plate (I)	095203-1	1
	<b>TOE BOARD KIT, MANUAL REAR</b>	094928	1
3	Plate Weldment, Manual Toe Board Rear	094926-1	1
4	Extension, Manual Toe Board Plate (II)	095202-1	1
5	Shaft, Manual Toe Board	090344-1	2
6	Nut, Special Threaded	090017	2
7	Pivot, Manual Toe Board Shaft (I)	094931-1	2
8	Ring, Z 22 Outside Retaining	F81090-24	2
9	Bearing, 5/8" Thrust	P04214	2
10	Collar, 16	F81039-6	2
11	Pin, 5x35-N-C PN-EN ISO 8752 Roll	F81044-9	6
12	Pin, 4x30 Zinc Roll	F81044-7	2
13	Bolt, M8 x 25-8.8-B Hex Head Full Thread Zinc	F81002-5	6
14	Nut, M8-8-B Hex Nylon Zinc Lock	F81032-2	6
	<b>CRANK ASSEMBLY, MANUAL TOE BOARD</b>	A09432	2
15	Crank, Manual Toe Board	W09431	1

# Log Clamp, Turner, Loader & Toe Boards

*Manual Toe Board*

9

16	Handle, Crank	S08291-W	1	
17	Screw, 3/8-16 x 2 1/2" Socket Head Cap	F05007-24	1	
18	Washer, 10.2 Split Lock Zinc	F81055-2	1	
19	Nut, 3/8-16 Hex Zinc	F05010-1	2	

# 9 Log Clamp, Turner, Loader & Toe Boards

## Manual Log Loader ( S/M type frame )

### 9.5 Manual Log Loader ( S/M Type Frame )

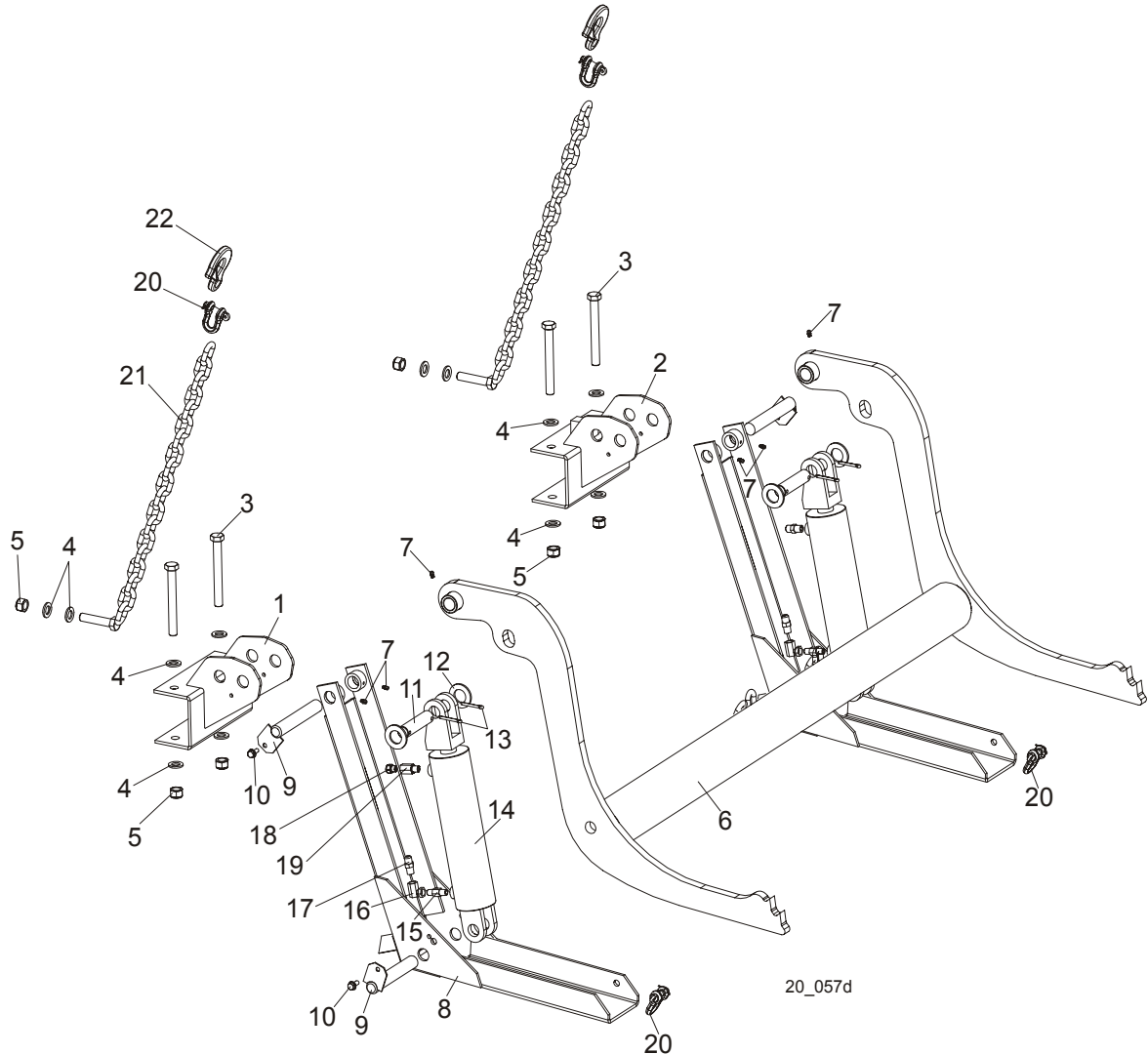

20\_057d

REF	DESCRIPTION (◆ Indicates Parts Available In Assemblies Only)	PART #	QTY.
	<b>LOG LOADER, LT20 COMPLETE</b>	091952	1
1	Bracket , Log Loader Mount Painted (S/M Type Frame)	092865-1	1
2	Bracket, LT20 Log Loader Mount	091938-1	1
3	Bolt, M16x140-8.8 Hex Head Zinc	F81006-4	4
4	Washer, 17 Zinc Flat	F81058-1	12
5	Nut, M16-8 Hex Nylon Zinc Lock	F81036-2	6
	Log Loader W/Chain, LT20	091954	1
6	Loader Weldment, Log Painted	090006-1	1
7	Fitting, 3/16" Straight Grease	P04107	6
8	Foot, Log Loader Painted	090048-1	2
9	Pin Weldment, Log Loader Painted	W09446-1	4
10	Screw, 5/16-18 x 3/4 Self-Tapping	F05015-30	4
11	Pin, Hydraulic Cylinder Zinc-Plated	086979-1	2

## Log Clamp, Turner, Loader & Toe Boards

*Manual Log Loader ( S/M type frame )*

9

12	Washer, 28 Zinc Flat	F81061-1	4	
13	Pin, 5x40 Cotter	F81043-31	4	
	Cylinder Assembly, LT20 Log Loader	094333	2	
14	Cylinder, CJ-S95-16-70/32/203 Hydraulic	088680	1	
15	Fitting, 1/4 NPT 4.0 GPM Velocity Fuse	015750	1	
16	Fitting, #9455X4X4 90 Deg. Swivel Elbow	P12199	1	
17	Fitting, 3/8JIC-1/4 NPT Straight	015560	1	
18	Air Vent Valve 2901-14-17	090794	1	
19	Fitting, $\frac{1}{4}$ " F. Thread/ $\frac{1}{4}$ " NPT M. Thread Reducer	090795	1	
20	Shackle, M-WL. .63	086540	4	
21	Chain, LT20 Log Loader Painted	091953-1	2	
22	Hook, 5/8 Safety Chain	P12075	2	

# 9 Log Clamp, Turner, Loader & Toe Boards

## Manual Log Loader ( L type frame )

### 9.6 Manual Log Loader ( L Type Frame )

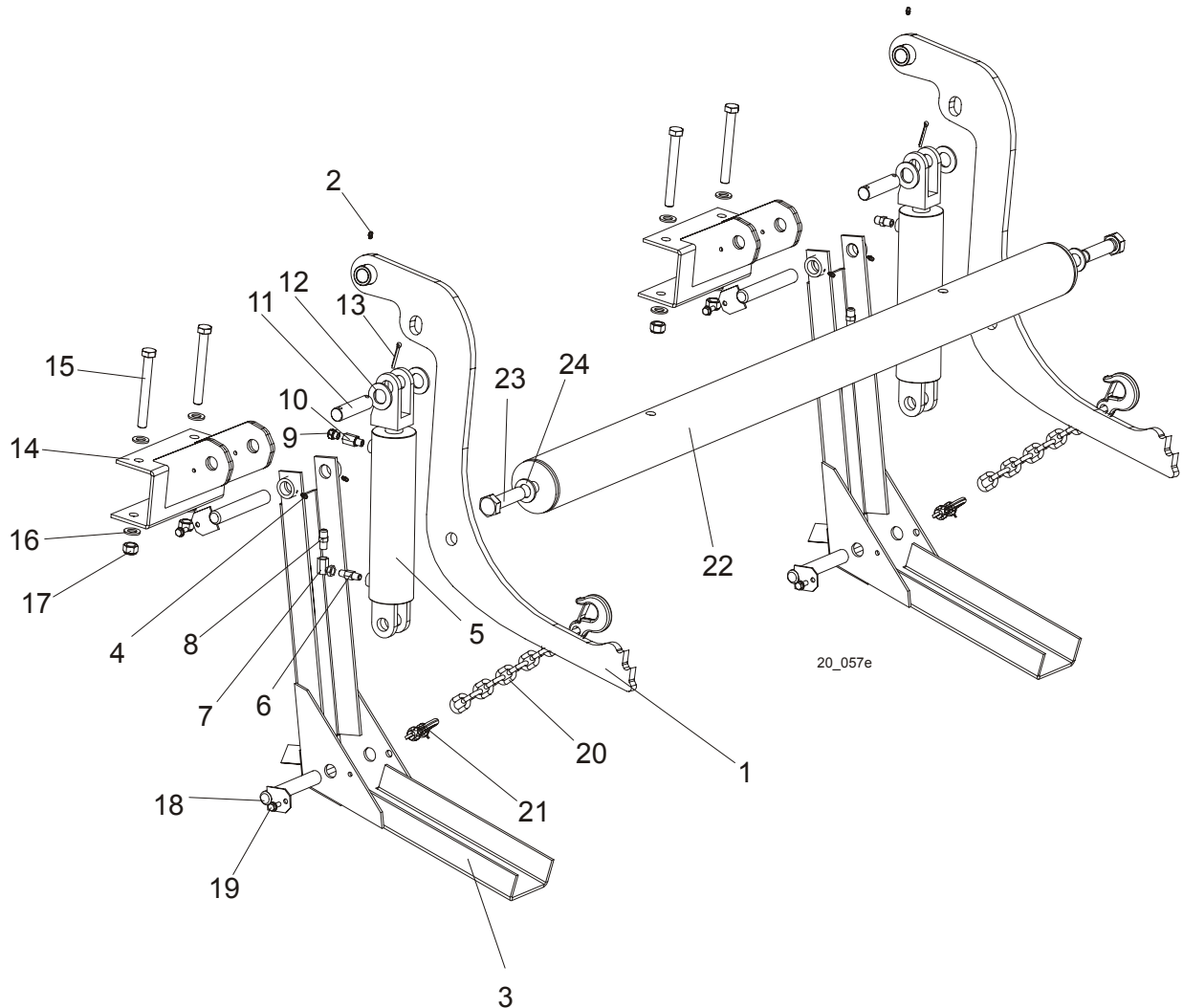

REF	DESCRIPTION (◆ Indicates Parts Available In Assemblies Only)	PART #	QTY.
	<b>LOG LOADER, SINGLE ARM, MH SAWMILLS</b>	094877	2
	Arm, Log Loader Single (9.5 m Frame)	090051	1
1	Arm Weldment, Log Loader Painted	089657-1	1
2	Fitting, 3/16" Straight Grease	P04107	1
	Foot Assembly, Log Loader	090049	1
3	Foot, Log Loader Painted	090048-1	1
4	Fitting, 3/16" Straight Grease	P04107	2
	Cylinder Assembly, LT20 Log Loader	094333	1
5	Cylinder, CJ-S95-16-70/32/203 Hydraulic	088680	1
6	Fitting, 1/4 NPT 4.0 GPM Velocity Fuse	015750	1
7	Fitting, #9455X4X4 90 deg. Swivel Elbow	P12199	1
8	Fitting, 3/8JIC-1/4 NPT Straight	015560	1
9	Air Vent Valve 2901-14-17	090794	1



# Log Clamp, Turner, Loader & Toe Boards

Manual Log Loader (L type frame)

9

10	Fitting, $\frac{1}{4}$ " F. Thread/ $\frac{1}{4}$ " NPT M. Thread Reducer	090795	1	
11	Pin, Hydraulic Cylinder Zinc-Plated	086979-1	1	
12	Washer, 28 Flat Zinc	F81061-1	2	
13	Pin, 5x40 Cotter	F81043-31	2	
14	Bracket Weldment, Log Loader Mount Painted	089841-1	1	
15	Bolt, M16x140-8.8 Hex Head Zinc	F81006-4	2	
16	Washer, 17 Flat Zinc	F81058-1	4	
17	Nut, M16-8 Hex Nylon Zinc Lock	F81036-2	2	
18	Pin Weldment, Log Loader Painted	W09446-1	2	
19	Screw, 5/16-18 x 3/4 Self-Tapping	F05015-30	2	
20	Chain, Log Loader Safety	090090-1	1	
21	Shackle, M-WL. .63	086540	1	
22	Link, Log Loader Arms	090315	1	
23	Bolt, M24x2x90-8.8 Hex Head Full Thread Zinc	F81009-2	2	
24	Washer, 25 Flat Zinc	F81061-3	2	

**9.7 Manual Log Loader Pump**

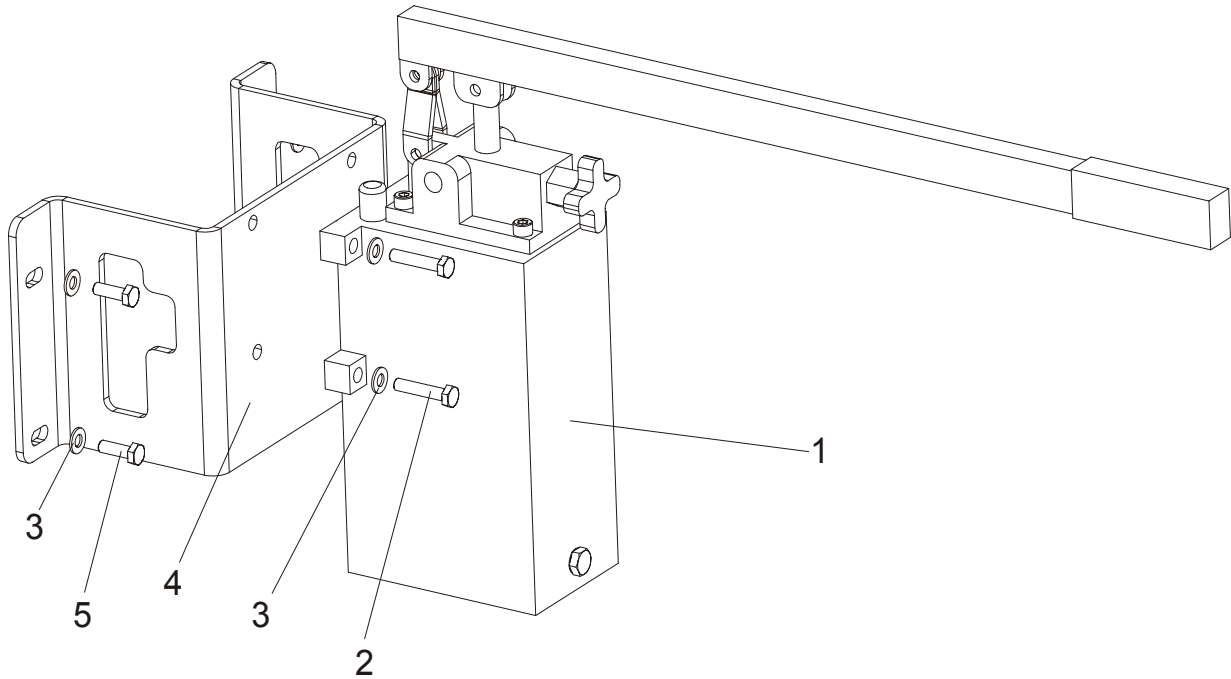

REF	DESCRIPTION (◆ Indicates Parts Available In Assemblies Only)	PART #	QTY.	
1	PUMP, PAM 014 2500 3L MANUAL	090309	1	
2	BOLT, M8X80-8.8 HEX HEAD ZINC	F81002-18	4	
3	WASHER, 8.4 ZINC FLAT	F81054-1	8	
4	BRACKET, LOG LOADER PUMP MOUNT	090377-1	1	
5	BOLT, M8X25-8.8-B HEX HEAD FULL THREAD ZINC	F81002-5	4	