

# Wood-Mizer<sup>®</sup> Sawmill

## Safety, Setup, Operation & Maintenance Manual

---

LT20

rev. A1.00

---



**Safety is our #1 concern!** Read and understand all safety information and instructions before operating, setting up or maintaining this machine.

*April 2003*

*Form #614*

# Table of Contents

# Section-Page

## SECTION 1 SAFETY & GENERAL INFORMATION

1-1

1.1	Blade Handling.....	1-2
1.2	Sawmill Setup.....	1-3
1.3	Sawmill Operation.....	1-4
1.4	Sawmill Maintenance.....	1-6
1.5	Belt Sizes.....	1-7
1.6	Blade Sizes.....	1-8
1.7	Cutting Capacity.....	1-9
1.8	Engine/Motor Specifications.....	1-10
1.9	Overall Dimensions.....	1-11
1.10	Chains.....	1-11
1.11	Components.....	1-12

## SECTION 2 SETUP & OPERATION

2-1

2.1	Stationary Sawmill Setup.....	2-1
2.2	Portable Sawmill Setup.....	2-4
2.3	Middle Track Cover.....	2-6
2.4	Replacing The Blade.....	2-7
2.5	Tensioning The Blade.....	2-8
2.6	Tracking The Blade.....	2-9
2.7	Starting The Motor.....	2-11
2.8	Loading, Turning, And Clamping Logs.....	2-12
2.9	Up/Down Operation.....	2-15
2.10	Blade Guide Arm Operation.....	2-16
2.11	Power Feed Operation.....	2-17
2.12	Cutting The Log.....	2-20
2.13	Edging.....	2-21
2.14	Blade Height Scale.....	2-22
2.15	Water Lube Operation.....	2-23
2.16	Preparing The Sawmill For Towing.....	2-24

# Table of Contents

# Section-Page

## SECTION 3 MAINTENANCE

3-1

3.1	Wear Life.....	3-1
3.2	Blade Guides .....	3-2
3.3	Sawdust Removal .....	3-2
3.4	Carriage Track, Wiper & Scrapers .....	3-3
3.5	Vertical Mast Rails .....	3-4
3.6	Miscellaneous .....	3-5
3.7	Blade Tensioner.....	3-6
3.8	Blade Wheel Belts .....	3-6
3.9	Brake Pads Adjustment ( Gas / Diesel Sawmills Only ) .....	3-7
3.10	Drive Belt Adjustment (Electric Sawmills Only).....	3-8
3.11	Up/Down System.....	3-10
3.12	Power Feed System .....	3-12

## SECTION 4 TROUBLESHOOTING GUIDE

4-1

4.1	Sawing Problems .....	4-1
4.2	Engine/Motor and Drive Pulleys Alignment .....	4-3

## SECTION 5 SAWMILL ALIGNMENT

5-1

5.1	Pre-Alignment Procedures.....	5-1
5.2	Frame Setup.....	5-1
5.3	Blade Installation And Alignment.....	5-2
5.4	Adjusting The Lower Track Rollers.....	5-4
5.5	Adjusting Bed Rails To The Blade.....	5-7
5.6	Blade Guide Arm Vertical Adjustment .....	5-9
5.7	Carriage Backlash Removal .....	5-11
5.8	Blade Guide Rope Adjustment.....	5-13
5.9	Blade Guide Arm Horizontal Adjustment.....	5-14
5.10	Aligning the Blade Guides .....	5-15
5.11	Blade Deflection.....	5-16
5.12	Blade Guide Vertical Tilt Adjustment.....	5-17
5.13	Blade Guide Spacing .....	5-19
5.14	Horizontal Tilt Adjustment.....	5-20
5.15	<b>Horizontal Adjustment of Side Supports .....</b>	<b>5-21</b>
5.16	<b>Vertical Adjustment of Side Supports.....</b>	<b>5-22</b>
5.17	Saw Head Tilt.....	5-23
5.18	Blade Height Scale Adjustment.....	5-24



## SECTION 1 SAFETY & GENERAL INFORMATION



This symbol calls your attention to instructions concerning your personal safety. Be sure to observe and follow these instructions. This symbol accompanies a signal word. The word **DANGER** indicates an imminently hazardous situation which, if not avoided, will result in death or serious injury. **WARNING** suggests a potentially hazardous situation which, if not avoided, could result in death or serious injury. **CAUTION** refers to potentially hazardous situations which, if not avoided, may result in minor or moderate injury to persons or equipment. Read all safety instructions before operating this equipment and observe all safety warnings!



Warning stripes are placed on areas where a single decal would be insufficient. To avoid serious injury, keep out of the path of any equipment marked with warning stripes.

Read and observe all safety instructions before operating this equipment! Also read any additional manufacturer's manuals and observe any applicable safety instructions including dangers, warnings, and cautions.

Always be sure that all safety decals are clean and readable. Replace all damaged safety decals to prevent personal injury or damage to the equipment. Contact your local distributor, or call your Customer Service Representative to order more decals.

**IMPORTANT!** It is always the owner's responsibility to comply with all applicable federal, state and local laws, rules and regulations regarding the ownership, operation and towing of your Wood-Mizer sawmill. All Wood-Mizer mill owners are encouraged to become thoroughly familiar with these applicable laws and comply with them fully while using or towing the mill.

Always properly dispose of all sawing by-products, including sawdust and other debris, coolant, oil, fuel, oil filters and fuel filters.

Safety instructions are listed in this section by the following operations:

- Blade Handling
- Sawmill Setup
- Sawmill Operation
- Sawmill Maintenance

## 1.1 Blade Handling



**DANGER!** Always disengage the blade and shut off the sawmill engine before changing the blade. Failure to do so will result in serious injury.



**WARNING!** Always wear gloves and eye protection when handling bandsaw blades. Changing blades is safest when done by one person! Keep all other persons away from area when coiling, carrying or changing a blade. Failure to do so may result in serious injury.



**WARNING!** Do not spin the blade wheels by hand. Spinning the blade wheels by hand may result in serious injury.

## 1.2 Sawmill Setup



**WARNING!** Chock the trailer wheels to prevent movement before unhitching it from the towing vehicle. Failure to do so may result in serious injury or death.

**WARNING!** Failure to put front outrigger down before moving cutting head from the rest position may result in serious injury.

**WARNING!** Securely fasten the feet of a stationary sawmill to the floor before operating the sawmill. Failure to do so may result in serious injury or death.

**WARNING!** Always make sure the trailer is supporting the sawmill frame when operating a sawmill with adjustable outriggers. Failure to do so may result in serious injury or death. The adjustable outriggers are intended to support the saw frame with assistance from the trailer.

**WARNING!** Do not set up the mill on ground with more than a 10 degree incline. If setup on an incline is necessary, put blocks under one side of the mill or dig out areas for outrigger legs to keep mill level. Setting up the mill on an incline could cause it to tip over, resulting in serious personal injury.



**CAUTION!** Changes in temperature could cause increased pressure in the blade tensioner and loss of fluid from the gauge. Release the blade tension when the mill is not in use to avoid damage to the tensioner.

### 1.3 Sawmill Operation



**DANGER!** Make sure all guards and covers are in place and secured before operating or towing the sawmill. Failure to do so may result in serious injury.

Be sure the blade housing and pulley covers are in place and secure. Use the safety retainer pin and cable to fasten blade housing covers.

**DANGER!** Always keep hands away from moving bandsaw blade. Failure to do so will result in serious injury.

**DANGER!** Stay clear of the area between the trailer axle and saw carriage. Failure to do so will result in serious injury.

**DANGER!** Keep all persons out of the path of moving equipment and logs when operating sawmill or loading and turning logs. Failure to do so will result in serious injury.

**DANGER!** Maintain a clean and clear path for all necessary movement around the mill and lumber stacking areas. Failure to do so will result in serious injury.

**DANGER!** Always be sure the blade is disengaged and all persons are out of the path of the blade before starting the engine or motor. Failure to do so will result in serious injury.

**DANGER!** Keep all persons out of the path of returning boards. Failure to do so will result in serious injury.



**WARNING!** Always disengage the clutch/brake mechanism whenever the sawmill is not cutting. Failure to do so may result in serious injury.

**WARNING!** Always wear eye, ear, respiration, and foot protection when operating the sawmill. Failure to do so may result in serious injury.



**WARNING!** Secure all loose clothing and jewelry before operating the sawmill. Failure to do so may result in serious injury or death.



**WARNING!** Always make sure log is clamped securely before sawing. Failure to do so may result in serious injury or death.

**WARNING!** Use ONLY water with the water lube accessory. Never use flammable fuels or liquids. If these types of liquids are necessary to clean the blade, remove it and clean with a rag. Failure to do so may result in serious injury or death.



**CAUTION!** Be sure the pivot rails, turning arm, clamp, and toe boards are below bed level before loading a log onto the bed. Failure to do so may result in machine damage or cause misalignment.

**CAUTION!** Before loading a log, be sure the cutting head is moved far enough forward so the log does not hit it. Failure to do so may result in machine damage.

**CAUTION!** Do not try to force the saw head beyond its upper and lower travel limits. Damage to the up/down system may result.

**CAUTION!** Do not use the blade guide arm knob to move the carriage head forward and backward. Damage to the blade guide arm may result.

**CAUTION!** Be sure to stop the blade when returning the carriage. This will not only prevent the blade from being pulled off and ruined by a wood sliver, but also will increase the life of the blade.

## 1.4 Sawmill Maintenance



**WARNING!** Always secure the cutting head with a chain or a brace before adjusting the up/down chain. The cutting head may fall, causing severe injury or death.

**WARNING!** Always secure the cutting head with a chain or a brace before adjusting the mast pads. The cutting head may fall, causing severe injury or death.



**CAUTION!** Do not over-grease the blade guide bearings. Over-greasing will push the seals out of the bearings causing premature failure.

**CAUTION!** Reinstall the track wiper so that it lightly touches the track rail. If the wiper presses too firmly against the rail, it can cause the power feed to bind.

**CAUTION!** Never use grease on the mast rails as it will collect sawdust.

**CAUTION!** Do not use chain lube. It causes sawdust buildup in chain links.

**CAUTION!** Due to variations in the vertical mast, the pad spacing may vary throughout the travel of the saw head. Check the pad spacing at the top and bottom ends of the mast only. Pads adjusted too tight will cause premature up/down motor failure.

**CAUTION!** It is important that the lower stop bolts are properly adjusted to secure the carriage on the track rail. Failure to properly adjust the stop bolts can cause saw head damage, especially during mill transportation.

## 1.5 Belt Sizes

See Table 1-1. Belt sizes for the LT20 are shown.

Description	Belt Size	Wood-Mizer Part #
Motor Drive Belt E11 & E15 <sup>1</sup>	BX81	014819
Engine Drive Belt G13, G15 & D17 <sup>2</sup>	BX831/2	088110
Blade Pulley Belts	B57 <sup>3</sup>	P04185

**TABLE 1-1**

<sup>1</sup> E15 motor uses two BX81 belts.

<sup>2</sup> D17 engine uses two such belts.

<sup>3</sup> To insure proper blade tracking, use Goodyear, Dayco Super II, or Browning belts only.

# 1 Safety & General Information

## Blade Sizes

### 1.6 Blade Sizes

See Table 1-2. Wood-Mizer TRU•SHARP™ offers three types of blades to provide efficient sawing for all models of sawmills. The engine/motor size of your sawmill and the type of wood you saw should determine which blade you choose for optimum performance.

Engine/Motor Size	Recommended Blade Type		
	Softwood	Medium Hardwood	Frozen Timber or Dense Hardwood
5 HP - 15 HP	.042 x 7/8 x 1 1/4"	.035 x 7/8 x 1 1/4 "	.045 x 7/8 x 1 1/4" F1 <sup>1</sup>
16 HP or more	.045 x 7/8 x 1 1/2"	.042 x 7/8 x 1 1/4 " .045 x 7/8 x 1 1/2" <sup>2</sup>	.045 x 7/8 x 1 1/4" F1 <sup>1</sup>
Electric Motor	.045 x 7/8 x 1 1/2"	.042 x 7/8 x 1 1/4 " .045 x 7/8 x 1 1/2" <sup>2</sup>	.045 x 7/8 x 1 1/4" F1 <sup>1</sup>

<sup>1</sup> TRU•SHARP™ "F" 9° blades use a 9/29 profile (9° hook angle and 29° back angle) and are designed to cut frozen and/or extremely dense, hard-to-cut wood. Standard TRU•SHARP™ blades use a 10/30 profile.

<sup>2</sup> Customer may choose preferred blade.

See *The Blade Handbook* for blade hook angle, tooth height, and tooth set specifications.

## 1.7 Cutting Capacity

See Table 1-3. The log size capacities of the LT20 sawmill are listed below.

	Max. Diameter <sup>1</sup>	Max. Length <sup>1</sup>
LT20	71 cm	5.1 m (16' 8")
LT20L	71 cm	6.4 m (21')

TABLE 1-3

<sup>1</sup> Maximum log capacity for a basic mill is 2000 Kg.

See Table 1-4. The performance capacity of the LT20 sawmill is listed below. Peak cutting rates are measured in 12" (30 cm) wide red oak and represent the capability of the sawmill only. Rates based on using Tru-Sharp 1 1/4" x .042 blades.

Model	Linear Blade Speed	Maximum Cutting Speed
LT20/20L G15	---	5.2 m/min.

TABLE 1-4

# 1 Safety & General Information

## Engine/Motor Specifications

### 1.8 Engine/Motor Specifications

See Table 1-5. The power options available for the LT20 sawmill are listed below.

Engine/Motor Type	Manufacturer	Model No.	Power	Other Specifications
15HP Gasoline	Kohler	PA44501	15 HP	---
11HP Electric	Tamel SA, Poland	Sg 112M-2PE	7.5 kW	14.7 A, 2950 RPM
13HP Gasoline	Kohler		13 HP	
11HP Electric				
15HP Electric	Tamel			2800 RPM
17HP Diesel	Kubota		17 HP	

TABLE 1-5

See Table 1-6. The noise levels of the Wood-Mizer sawmills are listed below.

	Idle	Engaged
Sawmill Equipped With Gas Engine	95 dB (A)	98 dB (A)
Sawmill Equipped With Electric Motor	79 dB (A)	93 dB (A)

TABLE 1-6

## 1.9 Overall Dimensions

See Table 1-7. The overall dimensions of the Wood-Mizer sawmills are listed below.

Model	Length <sup>1</sup>	Width <sup>2</sup>	With (Operating Position with Loading Arms)	Height <sup>3</sup>	Weight	Weight w/Trailer
LT25 G15 w/Trailer	6.7 m	2 m	3.5 m	2.5 m	923 kg	1068 kg
LT25L G15	8 m	2 m	3.5 m	2.5 m	1013 kg	1158 kg

TABLE 1-7

<sup>1</sup> Length from hitch to chain bracket.

<sup>2</sup> Width from fender to fender.

<sup>3</sup> Height from ground to mast. Placing head in maximum position will add to total height.

## 1.10 Chains

See Table 1-8. The load capacity of the chains is listed below.

	Load Capacity According to ISO Nr 08A-1
Up/Down Chain	2270KG

TABLE 1-8

# 1 Safety & General Information

## Components

---

### 1.11 Components

See **Figure 1-1**. The major components of the Wood-Mizer LT20 are shown below.

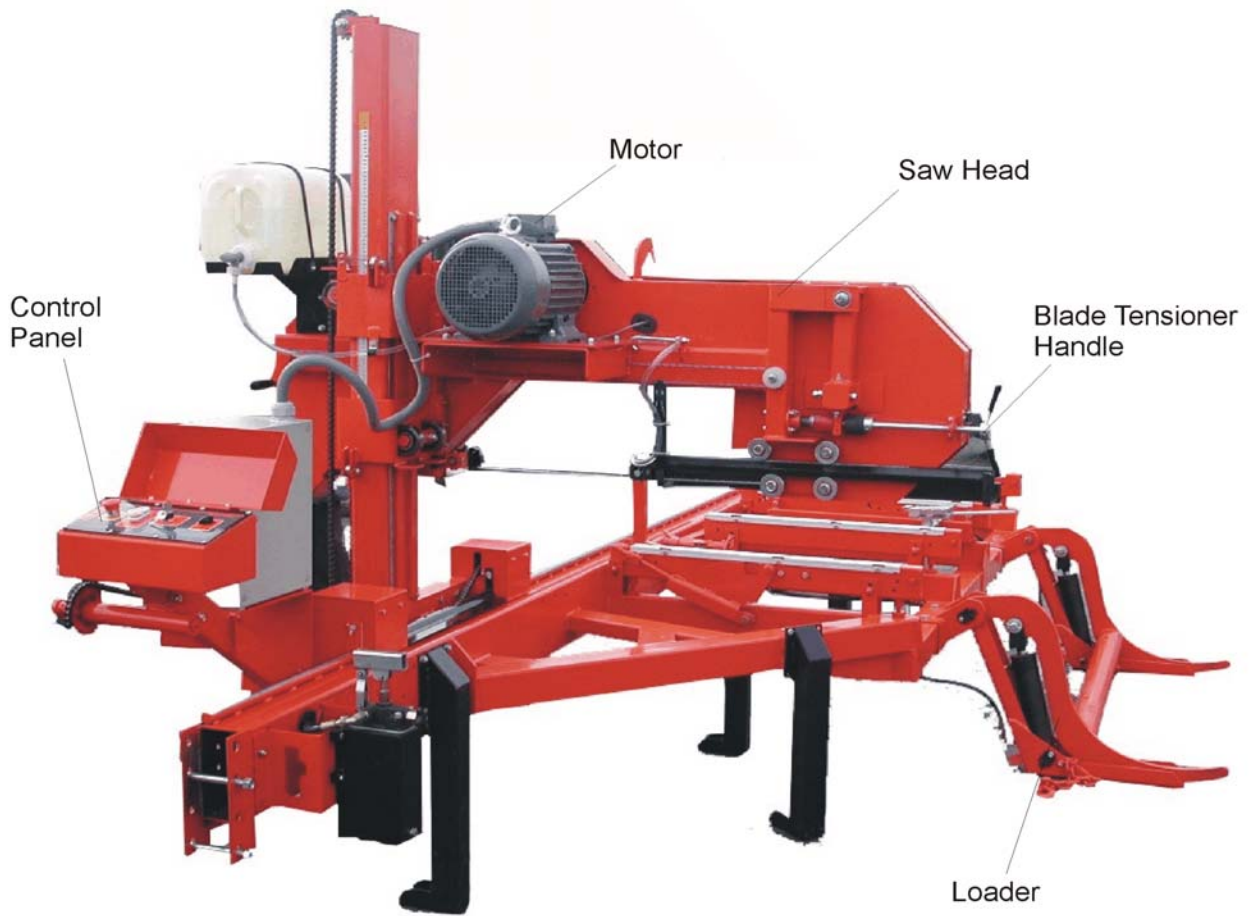

**FIG. 1-1**



## SECTION 2 SETUP & OPERATION

### 2.1 Stationary Sawmill Setup

Set up the mill on firm footing and level by eye. Fasten the mill to the floor to prevent any creep after prolonged use. A cement pad with 5/8" (16 mm) diameter anchor bolts is recommended. The cement pad should be rated to support 6350 lbs./sq.ft. (31 T/m<sub>2</sub>) at each sawmill foot position.

**NOTE:** Make sure the unit is level before securing. The sawmill mast should not be tilted from the vertical more than 3° towards the log loader. The mast should not be tilted in the opposite direction.

 **WARNING!** Do not operate a stationary sawmill without the feet securely fastened to the floor.

See Figure 2-1. Sawmill Mast Tilt

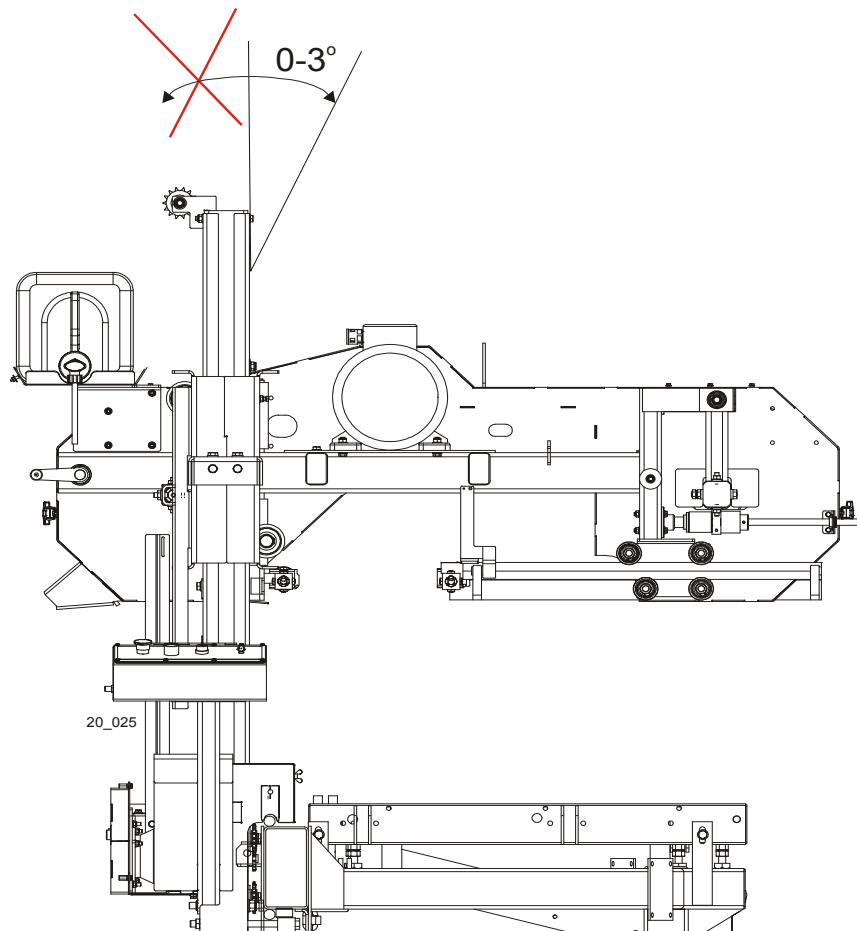
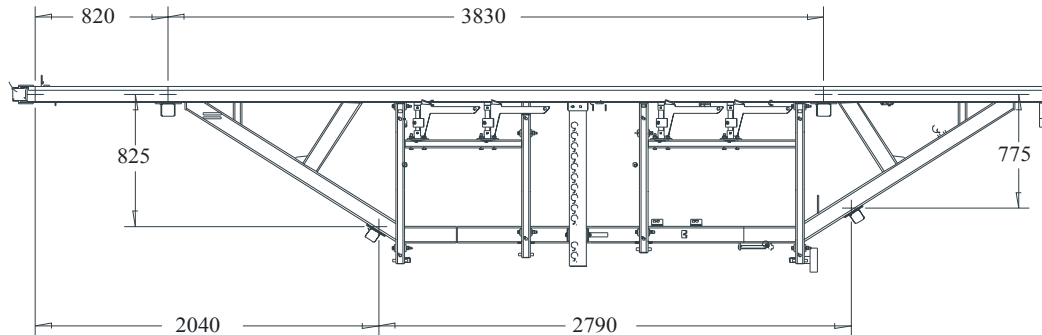
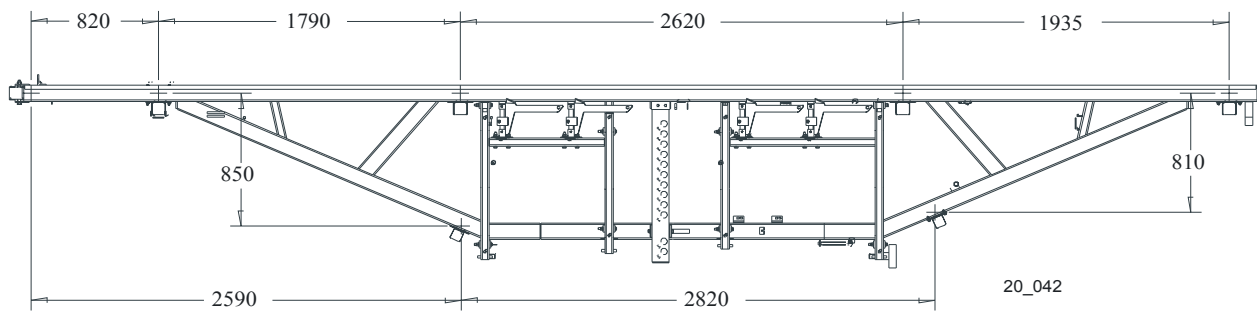

FIG. 2-1



LT20/LT30 Stationary Sawmill\*



LT20L/LT40 Stationary Sawmill\*

\*All dimensions in millimetres

FIG. 2-2

1. Unhook the carriage safety chain, located at the bottom of the vertical mast.
2. Use the up/down crank or the up/down switch to raise the cutting head from the carriage rest pin. Swing the rest pin below bed level.
3. Use the power feed switch to move the cutting head toward the front end of the mill. Raise the two side supports that will prevent a log from falling off the side of the mill when loaded.

See Figure 2-3.

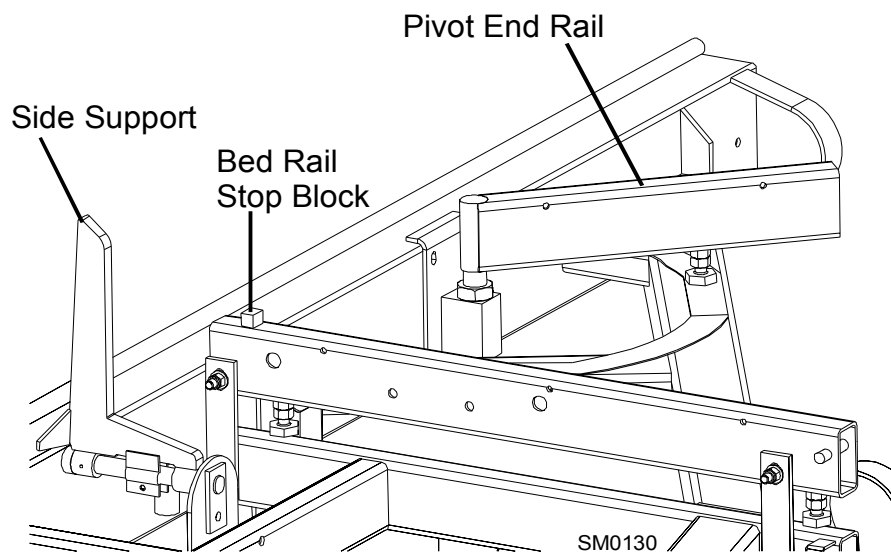

**FIG. 2-3**

## 2.2 Portable Sawmill Setup



**WARNING!** Do not set up the mill on ground with more than 3° incline. If setup on an incline is necessary, put blocks under one side of the mill or dig out areas for outrigger legs to keep mill level. Setting up the mill on an incline could cause it to tip over, resulting in serious personal injury.

**WARNING!** Chock the trailer wheels to prevent movement before unhitching it from the towing vehicle. Failure to do so will result in serious injury or death.

1. Unhitch the mill from the vehicle.
2. Lower and set the front three outriggers. Lift the weight from the locking pin using the jack handle. Pull the locking pin to release the outrigger and lower the outrigger as necessary. Secure with the locking pin.

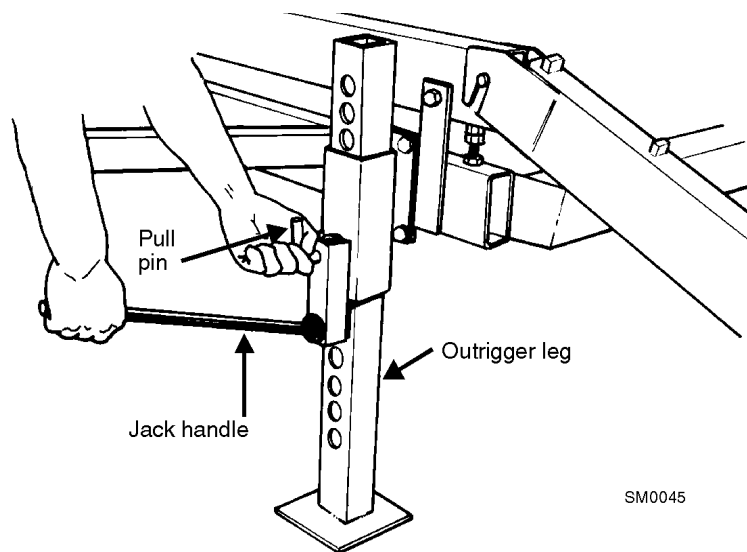

**FIG. 2-4. OUTRIGGER ADJUSTMENT.**

3. Unhook the carriage safety chain, located at the bottom of the vertical mast.
4. Use the up/down crank or switch to raise the cutting head from the carriage rest pin. Swing the rest pin down below bed level.



**WARNING!** Put front outrigger down before moving cutting head from the rest position. Failure to do so may result in serious injury.



**CAUTION!** To prevent fender damage, remove fenders

before operating sawmill or loading logs.

5. Use the power feed switch to move the cutting head toward the front or the rear end of the mill. Lower and set the remaining rear outriggers.
6. Level the sawmill by adjusting the outriggers to raise or lower each end of the sawmill. Adjust all outriggers evenly to avoid twisting the mill frame by jacking one outrigger higher than the others.

Raise the two side supports to prevent the log from falling off the side of the mill when loaded.

See Figure 2-5.

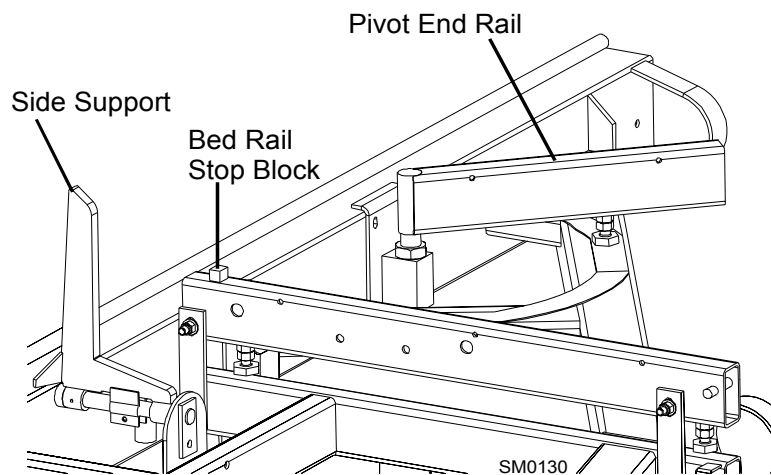

FIG. 2-5

## 2.3 Middle Track Cover

Before operating the sawmill do as follows:

1. Clean the upper and lower rails to remove any sawdust and rust preventives.
2. Unbolt and remove the middle track cover from its storage position.
3. Soak the felt wiper with Dexron III transmission fluid, 10W30 motor oil or 3-in-1 turbine oil.
4. Install the middle track cover so it fits against the rail and secure with two thumb screws.

See Figure 2-6.

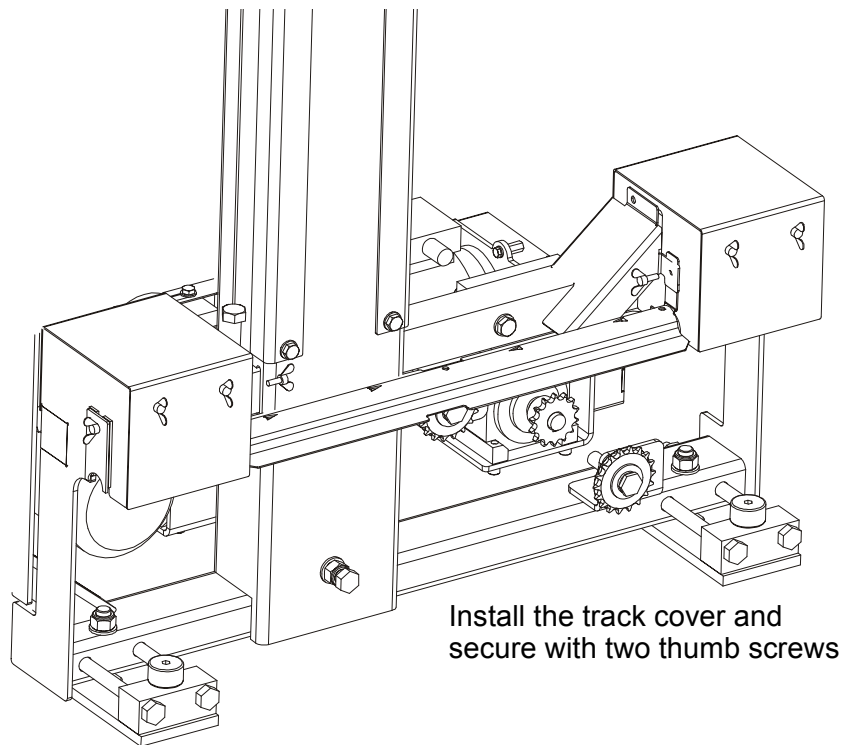

FIG. 2-6



**CAUTION!** Install the track cover so that it lightly touches the track rail. If the wiper presses too firmly against the rail, it can cause the power feed to bind.

## 2.4 Replacing The Blade



**DANGER!** Always shut off the sawmill motor before changing the blade. Failure to do so may result in serious injury.



**WARNING!** Always wear gloves and eye protection whenever handling bandsaw blades. Changing blades is safest when done by one person! Keep all other persons away from work area when changing blades. Failure to do so may result in serious injury.

Raise the blade housing cover. Turn the blade tension handle to release the blade tension until the wheel is pulled in and the blade is lying loose in the blade housing. Lift the blade out of the blade housing.

When installing a blade, make sure the teeth are pointing the correct direction. The teeth should be pointing toward the operator side of the mill when you are looking at the blade below the blade guides. Install the blade so it is lying around the wheels.

Position 1 1/4" wide blades on the wheels so the gullet is 1/8" (3 mm) +/- 1/16" (1.5 mm) out from the front edge of the wheel.

Close the blade housing cover.

Next, turn the tension handle until the blade is tensioned correctly.



**CAUTION!** Should you need to adjust the blade position, never grab the wheel arms to spin the idle-side blade wheel as your fingers can get pinched.

## 2.5 Tensioning The Blade

See **Figure 2-7**. Turn the blade tension handle clockwise to compress the rubber spring and tension the blade. Check the blade tension occasionally when adjusting the cant control or while cutting. As the blade and belts heat up and stretch, the blade tension will change. Also, ambient temperature changes can cause tension to change. Adjust the tension handle as necessary so that the indicator is parallel to the blade guide arm.

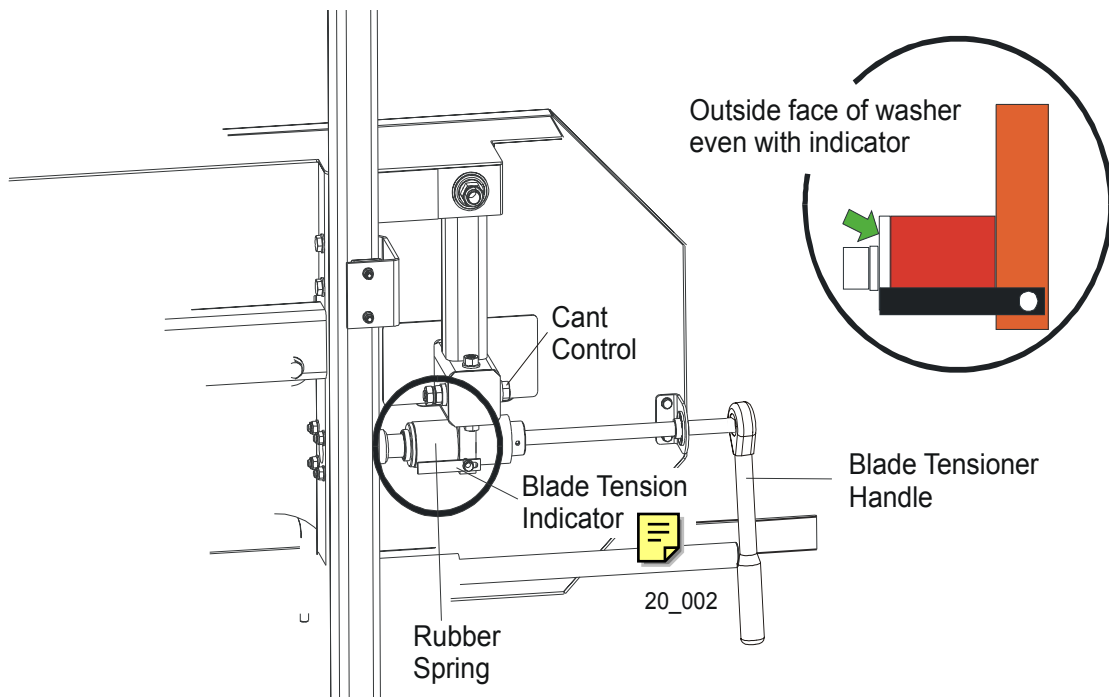

**FIG. 2-7**



**CAUTION!** Release the blade tension when the mill is not in use.



## 2.6 Tracking The Blade

1. Open the blade housing cover.
2. Turn the key switch to the "H" position.



3. Manually spin one of the blade wheels until the blade positions itself on the blade wheels.
4. Check if the blade is properly positioned on the blade wheels.

**See Figure 2-8.** Position 1 1/4" wide blade on the wheels so the gullet is 1/8" (3 mm) + 1/16" (1.5 mm) out from the front edge of the wheel.

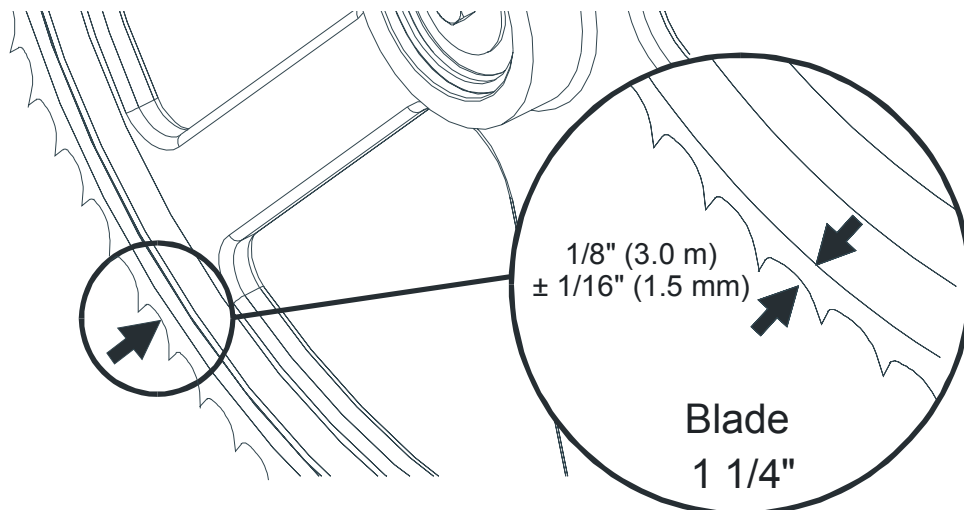

FIG. 2-8

5. Use the cant adjustment bolt, shown in **Figure 2-7** to adjust where the blade travels on the blade wheels.

To move the blade out on the blade wheel, turn the cant adjustment bolt clockwise. To move the blade in on the blade wheel, turn the bolt counterclockwise.

6. After adjusting the tilt of the blade wheels with the cant adjustment bolt, tension the blade properly.
7. Close the blade housing cover.



**DANGER!** Make sure all guards and covers are in place and secured before operating or towing the sawmill. Failure to do so may result in serious injury. Be sure the blade

## 2

## SETUP & OPERATION

### *Tracking The Blade*

---

housing cover is in place and secured.

**DANGER!** After aligning the blade on the wheels, always check the blade guide spacing and location. (See Section 5 for more information.)

## 2.7 Starting The Motor

See the appropriate manual supplied with your specific motor configuration for starting and operating instructions.



**DANGER!** Make sure all guards and covers are in place and secured before operating or towing the sawmill. Failure to do so may result in serious injury. Be sure the blade housing cover is in place and secured.

**DANGER!** Do not start the motor when the clutch/brake lever is in the engaged position. Always be sure the blade is disengaged and all persons are out of the path of the blade before starting the motor. Failure to do so will result in serious injury.



**WARNING!** Always wear eye, ear, respiration and foot protection when operating the machine. Secure all loose clothing and jewelry before operating the sawmill. Failure to do so may result in serious injury.

## 2 SETUP & OPERATION

### *Loading, Turning, And Clamping Logs*

## 2.8 Loading, Turning, And Clamping Logs



**CAUTION!** Make sure the pivot rails, turning arm, clamp, and toe boards are below bed level before loading a log onto the bed. Also, be sure the cutting head is moved far enough forward so the log does not hit it.

### To Load Logs:

1. Place the log on the loading arms. You can use a cant hook to do this. Roll the log onto the loader so that it is approximately centered with the sawmill bed. The log turner will operate much easier if the log is centered on the sawmill bed.
2. Raise the side supports.
3. Make sure the oil flow valve is closed. To close the valve, turn the valve knob clockwise. Moving the loader lever up and down, raise the loading arms until the log rolls onto the bed.

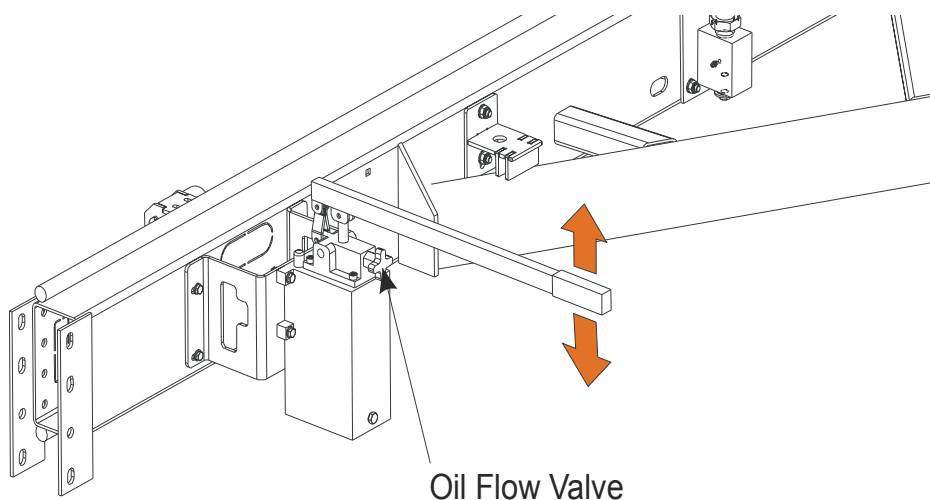

4. Lower the loading arms by opening the oil flow valve. To open the valve, turn the valve knob counterclockwise. Leave the loading arm halfway down while positioning the log on the bed. This will prevent the log from rolling off the bed.

**NOTE:** Logs also may be loaded onto the mill with a fork lift or other equipment specifically designed for that purpose.

**NOTE:** It is recommended that the log loader be left in the up position when the mill is not in use. This will prevent the hydraulic cylinders from corroding.

### To Turn Logs:

1. Use the log turner to rotate the log on the sawmill bed.
2. Spin the log against the side supports until it is turned the way you want it for the first cut. If you want to turn the log more, do the following steps.
3. Raise the turner arm to get a new bite on the log.
4. Disengage the clamp.
5. The log can be turned now. Repeat steps 4 through 7 until the log is turned as desired.

**To Clamp Logs:**

1. Position the clamp against the log.
2. Move the clamp down far enough so that it is below your first few cuts. Using the clamp lever, clamp the log against the side supports.

**See Figure 2-9.**

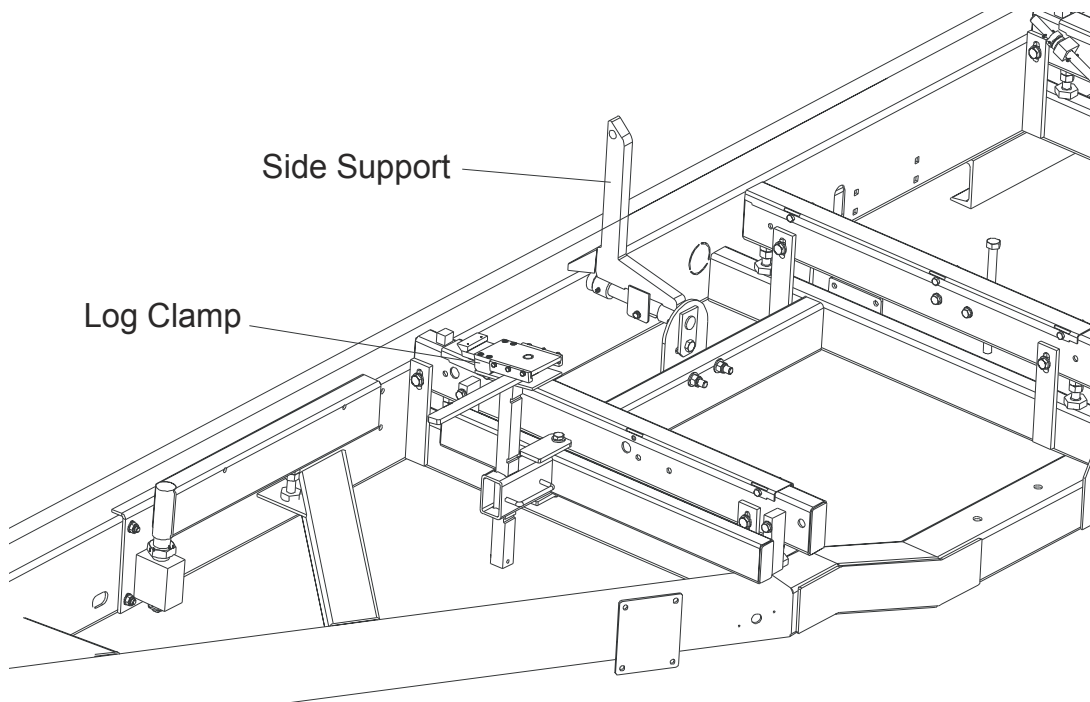

**FIG. 2-9**

3. Make sure the side supports are positioned low enough for the blade to pass over them. If they are not, back the clamp off slightly and push the side supports down until they are positioned below the level of your first few cuts.
4. Use the toe board levers to level the log if desired.

## 2

## SETUP & OPERATION

### *Loading, Turning, And Clamping Logs*

---

#### **To Level A Tapered Log:**

Use the toe board levers to raise either end of a tapered log, if desired.

## 2.9 Up/Down Operation

1. Install a blade and check for correct blade tension. ([See Section 2.4](#)).
2. Set the cutting head to the desired height. (The blade height scale shows the height of the blade above the bed rails.)



**See Figure 2-10.** The up/down switch is located on the right side of the control panel. Push the switch up to raise the cutting head; push the switch down to lower the cutting head. Hold the switch in position until the cutting head reaches the desired height, then release..

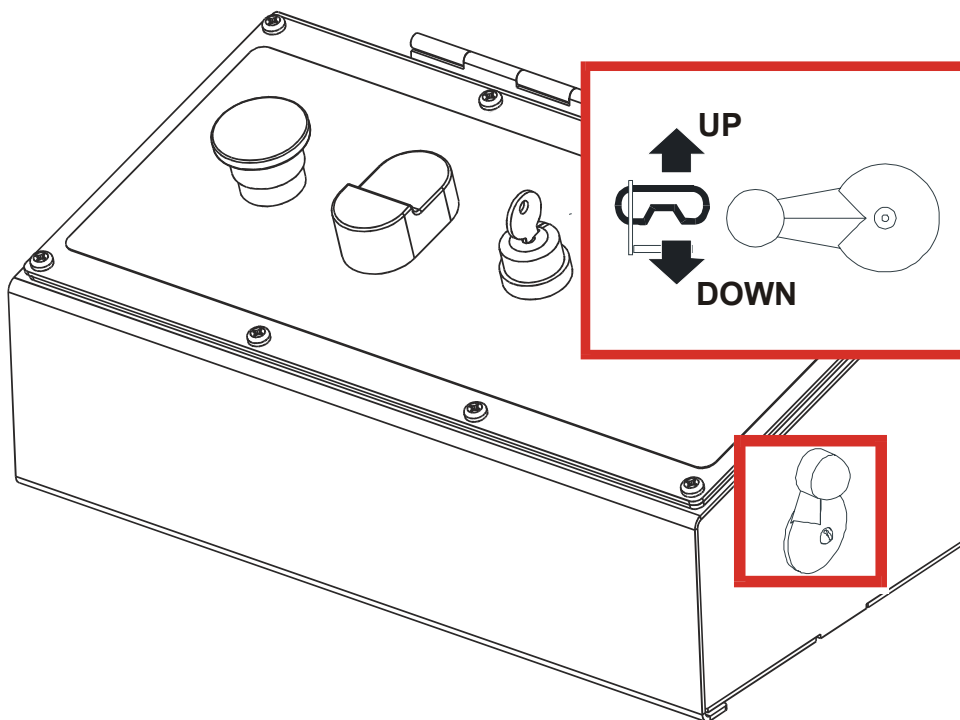

FIG. 2-10

The up/down switch is designed to return to the neutral position when released. If the switch remains engaged, manually move it to the neutral position. Repair the switch.



**CAUTION!** DO NOT try to force the carriage above the 35" (88 cm) mark or below the 1" (2.54 cm) mark. Damage to the up/down system may result.

## 2.10 Blade Guide Arm Operation

1. The outer blade guide should be adjusted so that it is about 1" (25.4 mm) from the log.
2. If necessary, use the blade guide arm crank to adjust the outer blade guide. Turn the crank clockwise to move the blade guide arm in, counterclockwise to move the arm out.

See Figure 2-11.

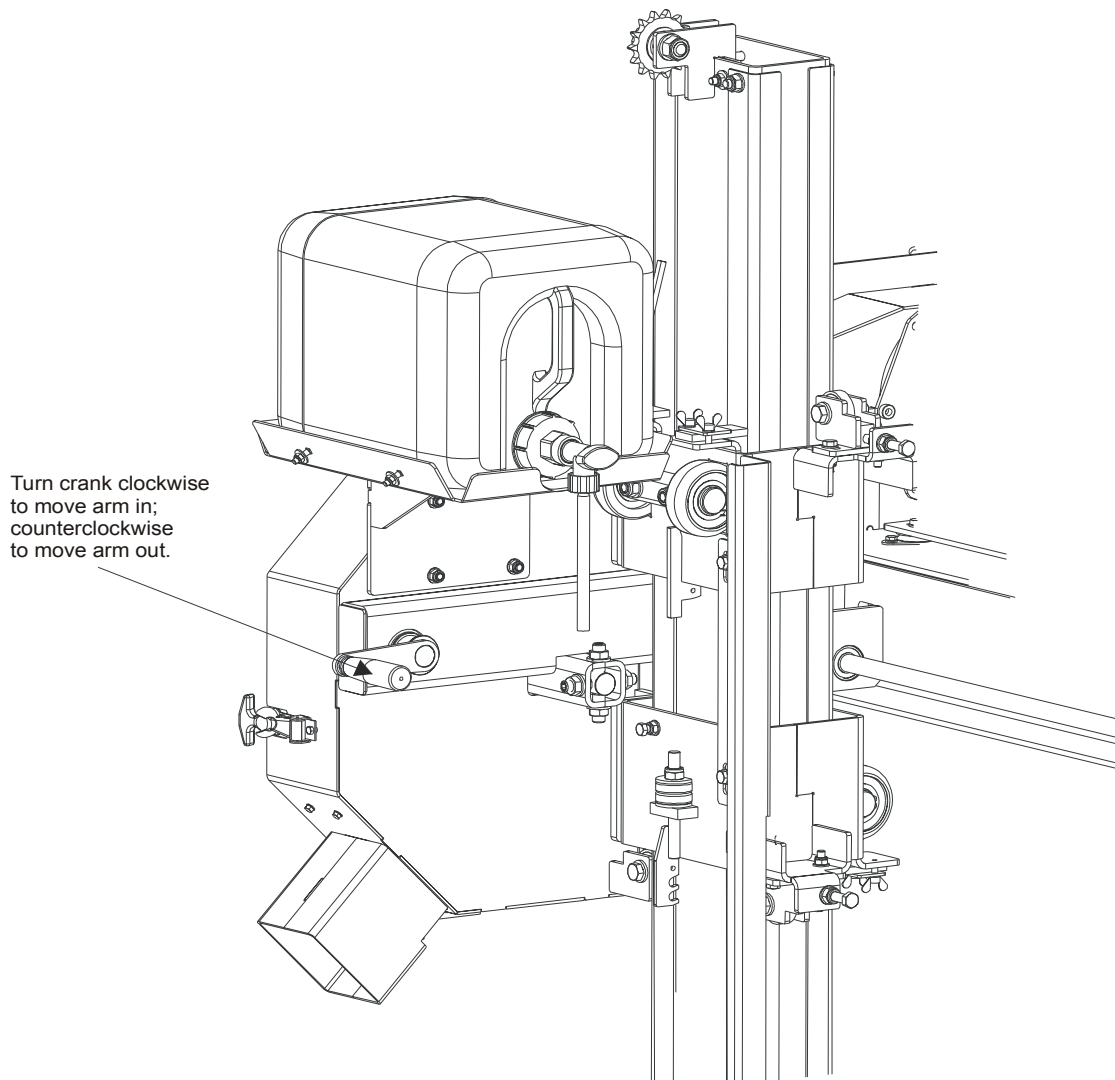

FIG. 2-11



## 2.11 Power Feed Operation

See Figure 2-12. The power feed system moves the carriage forward and backward by using two switches on the control panel.

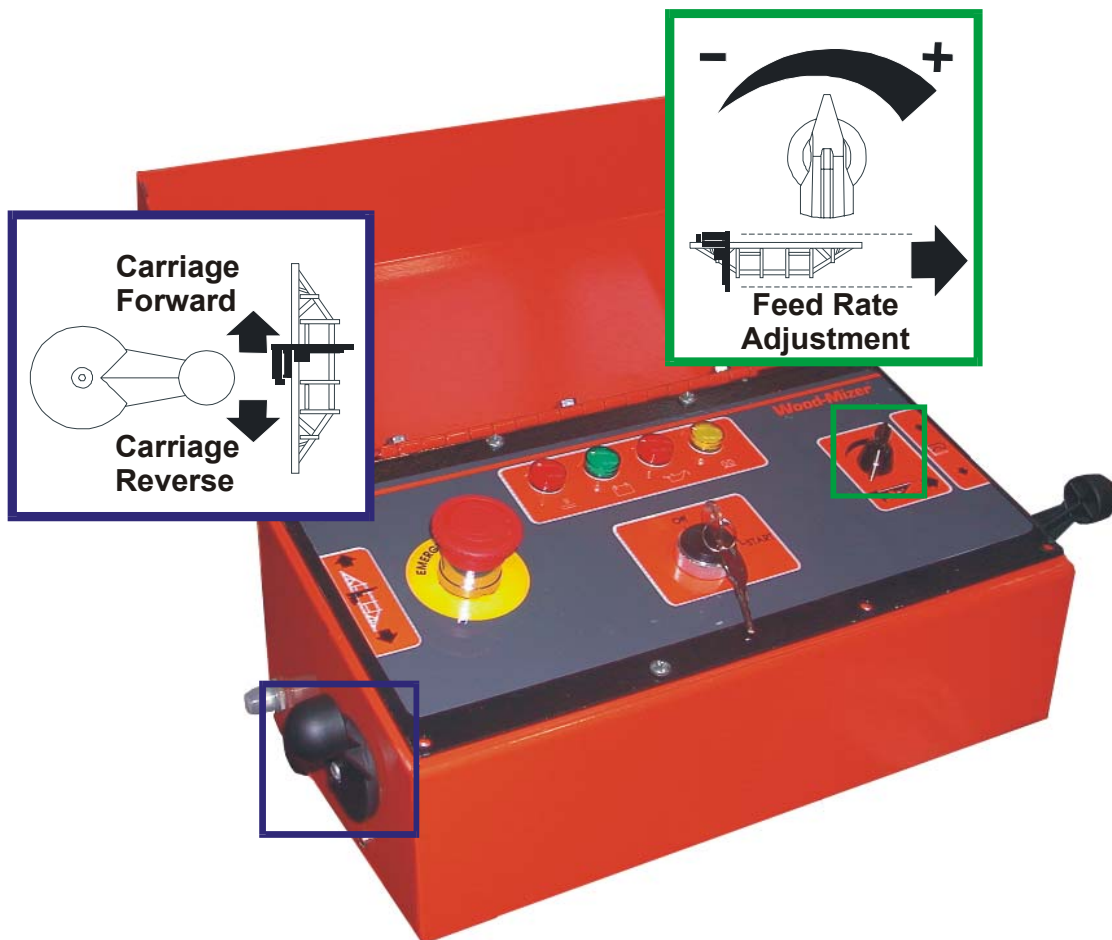

FIG. 2-12

### Carriage Feed Rate



The carriage feed rate switch controls the speed at which the carriage travels forward. Turn the switch clockwise to increase speed. Turn it counterclockwise to reduce speed.

### Carriage Forward and Reverse

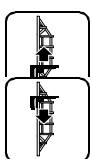

The power feed switch controls the direction in which the carriage travels. Turn the switch upward to move the carriage forward. Turn the switch down to move the carriage backward. NOTE: Always disengage the blade before returning the carriage and raise the carriage slightly to make sure the blade clears the log.

The middle position (shown in the figure above) is the neutral position. The power feed switch is designed to return to the neutral position when released. If the switch remains engaged, manually move it to the neutral position. Repair the switch ([See Section 4.2](#)).



**WARNING!** Be sure the power feed switch is in the neutral position before turning the key switch to the ON position. This prevents accidental carriage movement which may cause serious injury or death.

### Feed Rate

**HINT:** To get a straight cut in the first part of the log, feed the blade into the log at a slow speed. This stops the blade from flexing and dipping up or down. Turn the carriage feed rate switch to a slow speed until the whole width of the blade has entered the cut. Then use the carriage feed rate switch to increase the feed rate as desired.. Maximum feed rate varies with width and hardness of the wood. Over-feeding results in motor and blade wear, and also produces a wavy cut.



1.



Stop the carriage at the end of the cut by turning the carriage feed rate switch counter-clockwise until the carriage stops moving.

2. Using the clutch/brake lever, disengage the blade. This will stop the blade and drop the motor to idle. Remove the board from the log. ( DC )
3. Using the STOP button, disengage the blade. This will stop the blade. Remove the board from the log.( AC )



**CAUTION!** Be sure to stop the blade when returning the carriage. This will not only prevent the blade from being pulled off and ruined by a wood sliver, but also will increase the life of the blade.

4. Return the carriage to the front of the mill by turning the power feed switch down. The power feed motor will bypass the carriage feed rate switch and the carriage will automatically return at the fastest speed available. **Always disengage the blade before returning the carriage for the next cut.**



**CAUTION!** Do not use the blade guide arm crank to move the carriage forward and backward. Damage to the blade guide arm may result.

5. Make sure that the blade does not catch on the end of the log. Raise the carriage slightly to make sure the blade clears the log when returned. **HINT:** Try to stop the blade while the heel of the blade is still on the log. Then bring the carriage back without adjusting the blade up. This lets you keep the blade at the current height setting so you can make the next blade height adjustment more quickly.



**DANGER!** Stay clear of the area between the trailer axle and saw carriage. Failure to do so will result in serious injury.

## 2.12 Cutting The Log

The following steps guide you through normal operation of the Wood-Mizer sawmill.

1. Once the log is placed where you want it and clamped firmly, position the blade close to the end of the log.
2. Use the blade height scale to determine where to make your first cut ([Patrz rozdział 2.14](#)). Set the blade to the desired height with the up/down switch. Make sure that the blade will clear both side supports and the clamp.
3. Adjust the outer blade guide to clear the widest section of the log using the blade guide arm crank.



Make sure all guards and covers are in place. Engage the blade. To do this, turn the key switch to the "M" position and press the START button.

5. To prevent sap buildup on the blade, open the water bottle valve so that water flow to the blade. [See Section 2.19](#).
6. Feed the blade into the log slowly ([See Section 2.11](#)). Once the blade completely enters the log, increase the feed rate as desired. Always try to cut at the fastest speed you can while keeping an accurate cut. Cutting too slowly will waste blade life and lower production!
7. As you get to the end of the log, slow down the feed rate. When the teeth exit the end of the log, turn the power feed switch to the neutral position. Then disengage the blade using the STOP button. Remove the board that you have just cut from the log.
8. Use the **power feed switch** to move the carriage to the front of the mill. Always disengage the blade before returning the carriage for the next cut.
9. Repeat until the first side of the log is cut as desired. Set aside the usable flitches (boards with bark on one or both sides). You can edge them on the mill later.
10. Lower the toe boards, if they were used. Remove the clamp and turn the log 90 or 180degrees. Make sure the flat on the log is placed flat against the side supports if turned 90degrees. Make sure it is placed on bed rails if turned 180 degrees. If the log was turned 90degrees and you are using toe boards to compensate for taper in the log, raise the front or rear toe board again on the second side of the log until the heart is parallel with the bed.
11. Repeat the steps used to cut the first side of the log until the log is square. Cut boards from the remaining cant by adjusting the blade height for the thickness of boards that you want.

**Example:** Remember that the blade cuts a 1/16 - 1/8" (1.6-3.2 mm) wide kerf. If you want 1" (25.4 mm) thick boards, lower the carriage 1 1/16 - 1 1/8" (27-28.6 mm) for each board.

## 2.13 Edging

The following steps guide you through edging boards on the Wood-Mizer sawmill.

1. Raise the side supports to ~ the height of the flitches, or the boards that need to be edged.
2. Stack the flitches on edge against the side supports.
3. Clamp the flitches against the side supports. (Wider flitches should be placed to the clamp side. When they are edged, flip them over to edge the second side without disturbing the other flitches or without having to pull them from the middle of the stack.)
4. Adjust the blade height to edge a few of the widest boards.
5. Loosen the clamp and turn the edged boards over to edge the other side.
6. Repeat steps 2-4.
7. Loosen the clamp and remove the boards that have good clean edges on both sides. Clamp the remaining flitches and repeat steps 2-5.

## 2.14 Blade Height Scale

See Figure 2-13. The blade height scale is attached to the cutting head frame. It includes:

- a blade height indicator
- an inch scale.

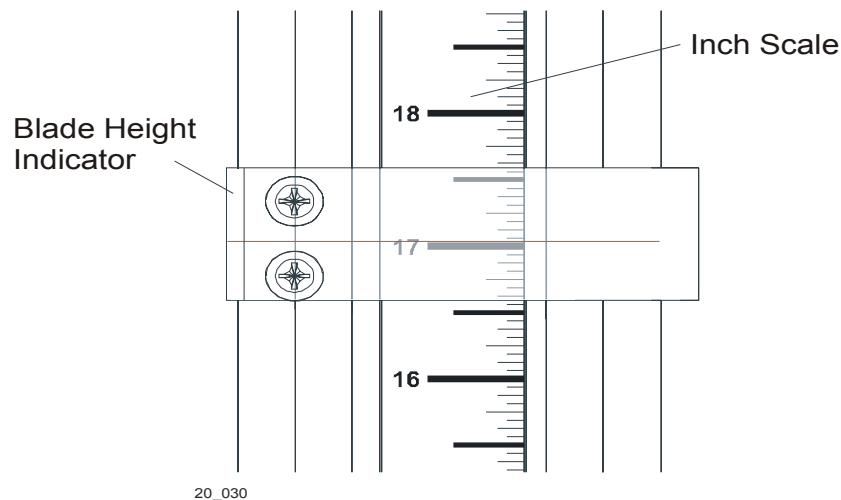

FIG. 2-13

### The inch scale

The horizontal red line on the blade height indicator shows how many inches the bottom of the blade is above the bed of the mill. If you know the height of your blade at each cut, you can determine the thickness of lumber you are sawing.

**Example:** You want to cut 1" (25 mm) random width boards from a log. Position the blade for the first cut. Move the carriage to an even measurement on the inch scale. Make a trim cut. Return the carriage for the second cut and lower it 1 1/8" (29 mm) below the original measurement. (The extra 1/8" (3 mm) allows for saw kerf and shrinkage of the lumber.)

The yellow area on the scale identifies where the blade could encounter a side support or log clamp. Check that these items are below the blade level before sawing.

## 2.15 Water Lube Operation

See Figure 2-14. The Water Lube System keeps the blade clean. Water flows from a 5-gallon (18.9 liter) bottle through a hose to the blade guide where the blade enters the log. A valve in the bottle cap controls the amount of water flow.

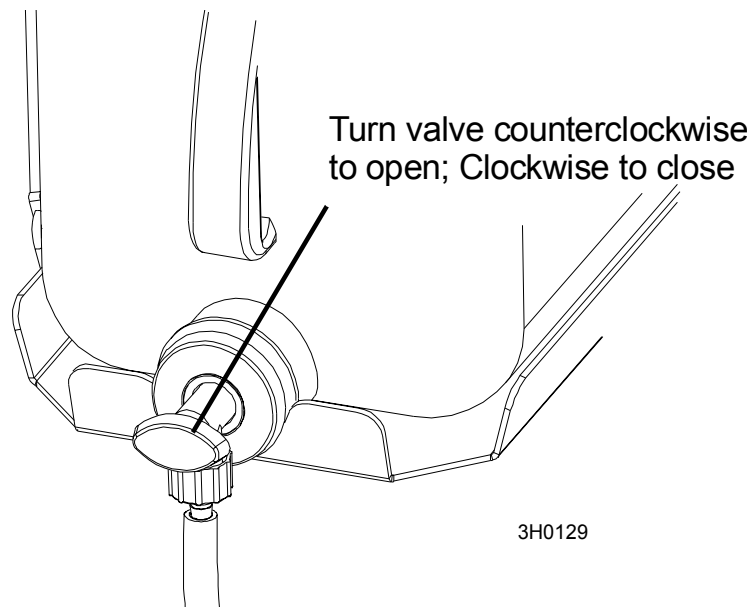

FIG. 2-14

Not all types of wood require the use of the Water Lube System. When it is needed, use just enough water to keep the blade clean. This saves water, and lowers the risk of staining the boards with water. Usual flow will be 1-2 gallons (3.8-7.6 liters) per hour. A squirt of liquid dishwashing detergent in the water bottle will help clean the blade when cutting wood with a high sap content.



**WARNING!** Use ONLY water with the water lube accessory. Never use flammable fuels or liquids. If these types of liquids are necessary to clean the blade, remove it and clean with a rag. Failure to do so may result in serious injury or death.

Before removing the blade, start the motor with the START button. Let the blade spin with water running on it for about 15 seconds. This will clean the blade of sap buildup. Wipe the blade dry with a rag before storing or sharpening.

If you are sawing in freezing temperatures, remove the water lube bottle from the sawmill when done sawing and store it in a warm place. Blow any remaining water from the water lube hose.

## 2.16 Preparing The Sawmill For Towing

The Wood-Mizer trailer package makes transporting your sawmill easy and convenient. To get your sawmill ready for towing, follow these instructions.

1. Move the cutting head to the front end of the sawmill. Raise the rear outriggers.
2. Move the cutting head to the travel position over the rear bed rail.
3. Position the hole in the cutting head over the travel rest pin.
4. Lower the cutting head until it is seated firmly on the rest pin.
5. Continue lowering the head 3/4" (19 mm) until it contacts the stop bolt located on the mast.



**CAUTION!** It is important that the stop bolt is properly adjusted to secure the carriage on the track rail. Failure to properly adjust the stop bolt can cause cutting head damage, especially during mill transportation.

6. Hook the carriage safety chain attached to the main bed tube, behind the trailer to the bracket located near the lower track roller.
7. Manually lift the log loader and secure it with the safety chain.

See Figure 2-15.

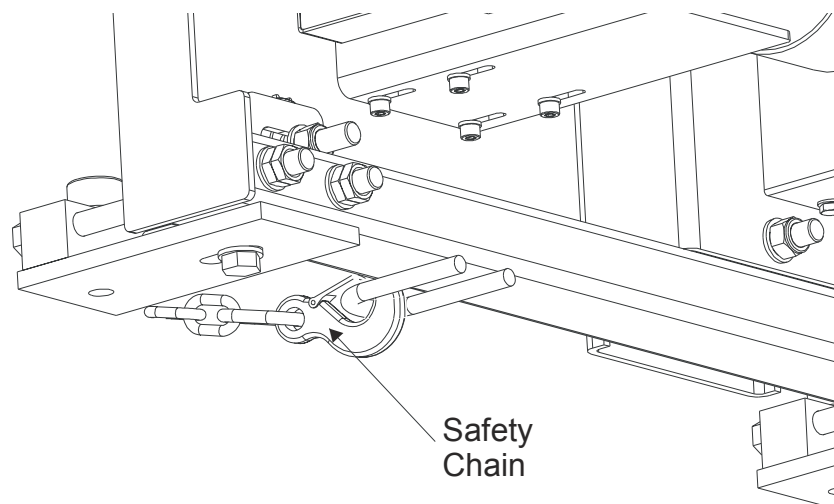

FIG. 2-15



**CAUTION!** Check to be sure that the carriage safety chain



is secured before towing the sawmill. Failure to properly secure the cutting head can result in severe machine damage. Be sure the blade housing cover is in place and secured.

8. Remove all loose objects from the bed of the mill. Store the cranks for toe boards in the brackets provided at the rear of the mill. Store the outrigger jack handle in the bracket on the outrigger guide.
9. Place both fenders in the slots located behind the trailer tires. Raise all but the very front outrigger.

See the trailer operator's manual for specific information regarding hitch operation and towing the sawmill.



## SECTION 3 MAINTENANCE

This section lists the maintenance procedures that need to be performed.

*The Short Interval Maintenance Schedule* lists procedures that need to be performed every 4, 8 or 24 hours. *The Maintenance Log* lists procedures that need to be performed every 50, 100, 200, or 1000 hours. Keep track of machine maintenance by filling in the machine hours and the date you perform each procedure.



**This symbol** identifies the interval (hours of operation) at which each maintenance procedure should be performed.

Be sure to refer to option and engine manuals for other maintenance procedures.

### 3.1 Wear Life

**See Table 3-1.** This chart lists estimated life expectancy of common replacement parts if proper maintenance and operation procedures are followed. Due to the many variables which exist during sawmill operation, actual part life may vary significantly. This information is provided so that you may plan ahead in ordering replacement parts.

Part Description	Estimated Life
B57 Blade Wheel Belts	500 hours
Blade Guide Rollers	1000 hours
Drive Belt	1250 hours

TABLE 3-1

### 3.2 Blade Guides

1. Check the rollers for performance and wear every blade change. Make sure the rollers are clean and spinning freely. If not, rebuild them. Replace any rollers which have worn smooth or have become cone shaped. See The LT20 Parts manual for blade guide rebuild kits and complete roller assemblies.

See Figure 3-1.

2. Make sure the blade screw in the top center of the C-frame is  $1/16"$  (1.5 mm) below the bottom of the blade. If not, loosen the nut and adjust the screw as necessary. Failing to maintain this adjustment will lead to early blade breakage.

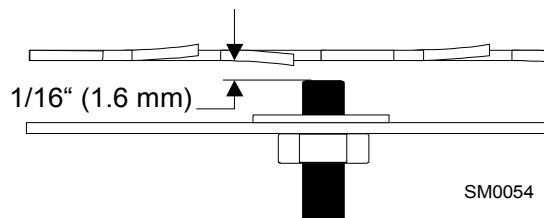

FIG. 3-1

### 3.3 Sawdust Removal

1. Remove the excess sawdust from the blade wheel housing and sawdust chute every blade change.

### 3.4 Carriage Track, Wiper & Scrapers

See Figure 3-2.

- 8 1. Clean the upper and lower track rails to remove any sawdust and sap buildup every eight hours of operation. Lubricate the lower track rail by wiping it with Dexron III ATF.
- 8 2. Remove sawdust from the upper cam housings. Loosen the thumb screws on the upper cam housing covers and open. Brush any sawdust buildup from the housings.
3. Check the track scrapers as needed. Make sure the scrapers fit firmly against the rail. If a track scraper needs to be adjusted, loosen the thumb screw, push the scraper downward until it fits firmly against the rail, and retighten the thumb screw.

25 Clean and lubricate the upper track wiper every twenty-five hours of operation. Unbolt the wiper, remove it from the sawmill, and remove any sawdust buildup. Soak the felt wiper with Dexron III transmission fluid, 10W30 motor oil or 3-in-1 turbine oil.

**CAUTION!** Reinstall the track wiper so that it lightly touches the track rail. If the wiper presses too firmly against the rail, it can cause the power feed to bind.

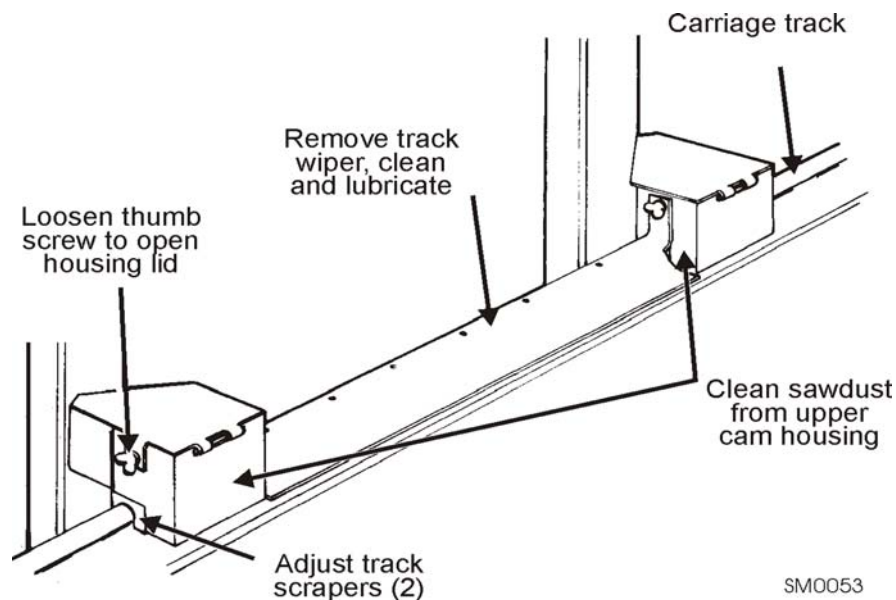

FIG. 3-2

### 3.5 Vertical Mast Rails

Lubricate the vertical mast rails with WD40, clean and wipe them dry every 50 hours of operation.



**CAUTION!** Never use grease on the mast rails as it will collect sawdust.

**FIG. 3-2**

### 3.6 Miscellaneous

1. Apply a thin film of a lithium grease to the blade guide arm to help prevent it from rusting.  
50
2. Lubricate the log turner (if equipped) with a lithium grease every fifty hours of operation. Lubricate the turner pivot points (e.g. with WD-40).  
50
3. Grease the side supports with a lithium grease every 50 hours of operation.  
50
4. Oil all chains with an easily penetrating oil such as WD-40.  
50



**CAUTION!** Do not use chain lube. It causes sawdust buildup in chain links.

5. Check the mill alignment every setup. See Section 5, Alignment.
6. Make sure all safety warning decals are readable. Remove sawdust and dirt. Replace any damaged or unreadable decals immediately. Order decals from your Customer Service Representative.

### 3.7 Blade Tensioner

1. Grease the tensioner handle screw with a lithium grease every fifty hours of operation, but at least once a week.

See Figure 3-3.

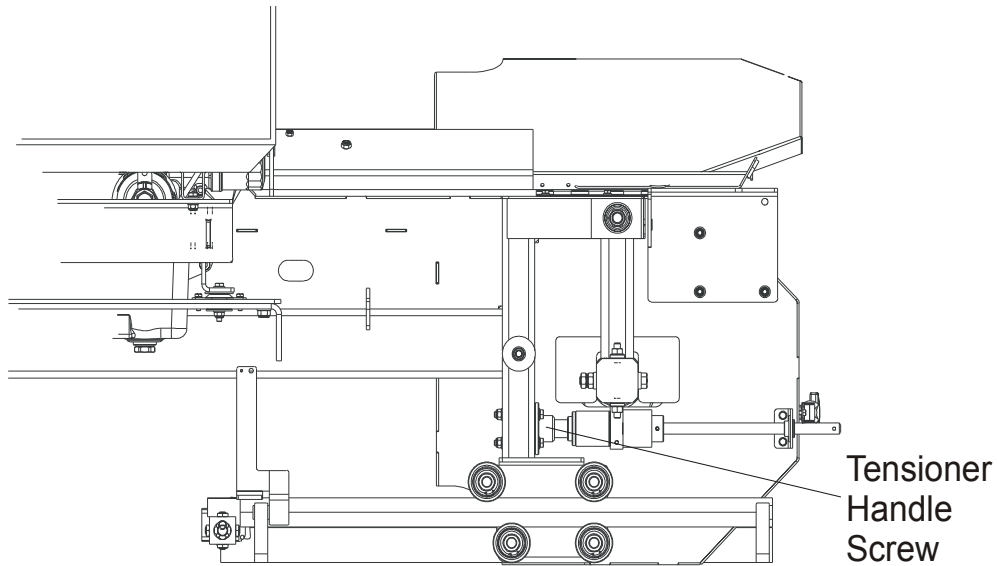

FIG. 3-3

### 3.8 Blade Wheel Belts

1. Check the blade wheel belts for wear every 50 hours of operation. Replace as needed.
2. Periodically check all belts for wear. Replace any damaged or worn belts as needed.



### 3.9 Brake Pads Adjustment ( Gas / Diesel Sawmills Only )



Check the brake pads for wear every 200 hours of operation. Replace if damaged or worn.

Adjust the brake pads if the blade does not stop quickly, unusual sounds occur when the brake is applied, or a sudden change is noticed in the clutch/brake lever position when the clutch is disengaged.



**WARNING!** Do not for any reason adjust the brake pads with the engine running. Doing so may result in serious injury.

Open the blade housing cover.

See **Figure 3-4**. Loosen the locking bolts shown below. Adjust the brake pads so the

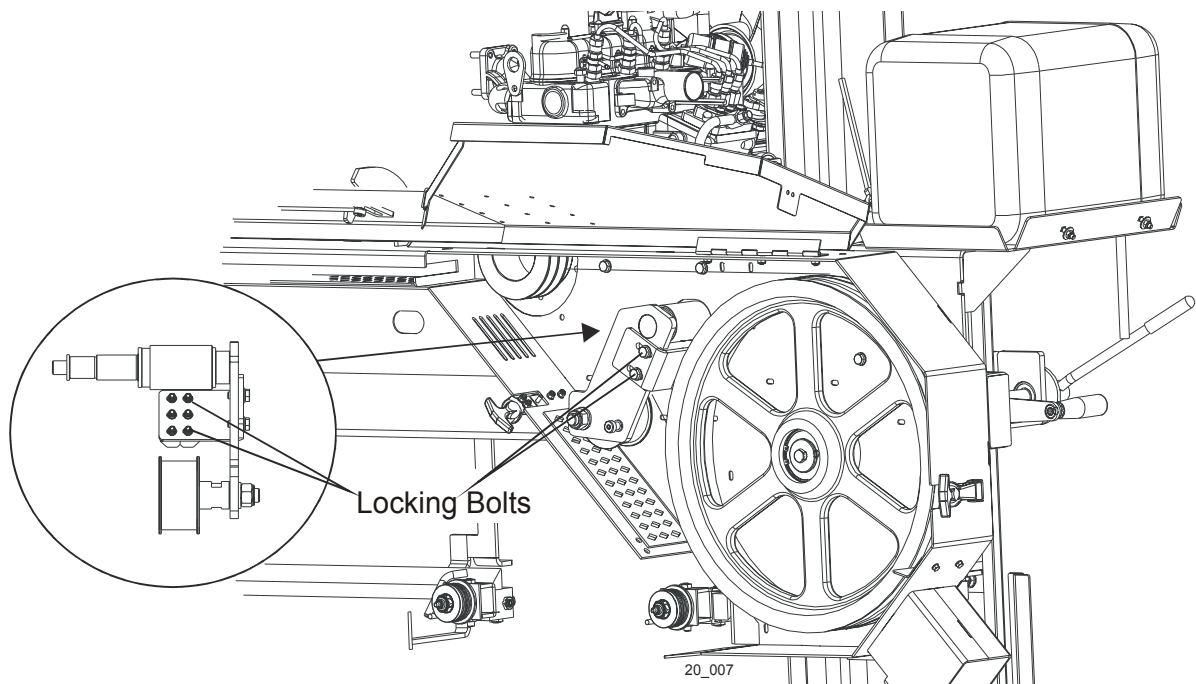

**FIG. 3-4**

blade stops no more than 10 seconds after disengaging. The brake pads should enter the grooves in the drive pulley when the brake is applied. If they are not, it can lead to their premature wear.

### 3.10 Drive Belt Adjustment (Electric Sawmills Only)



**WARNING!** Do not for any reason adjust the drive belts with the motor running. Doing so may result in serious injury.

50

See **Table 3-2**. Check the drive belt tension after the first 20 hours, and every 50 hours thereafter. See the table below for drive belt tension specifications for your sawmill.

Motor/Engine	Belt Tension
E11, G13	7/16" (11mm) deflection with 8 lbs. (3.6 KG) of deflection force
E15, G15, D17	7/16" (11mm) deflection with 16 lbs. (7,2 KG) of deflection force (two belts)

TABLE 3-2

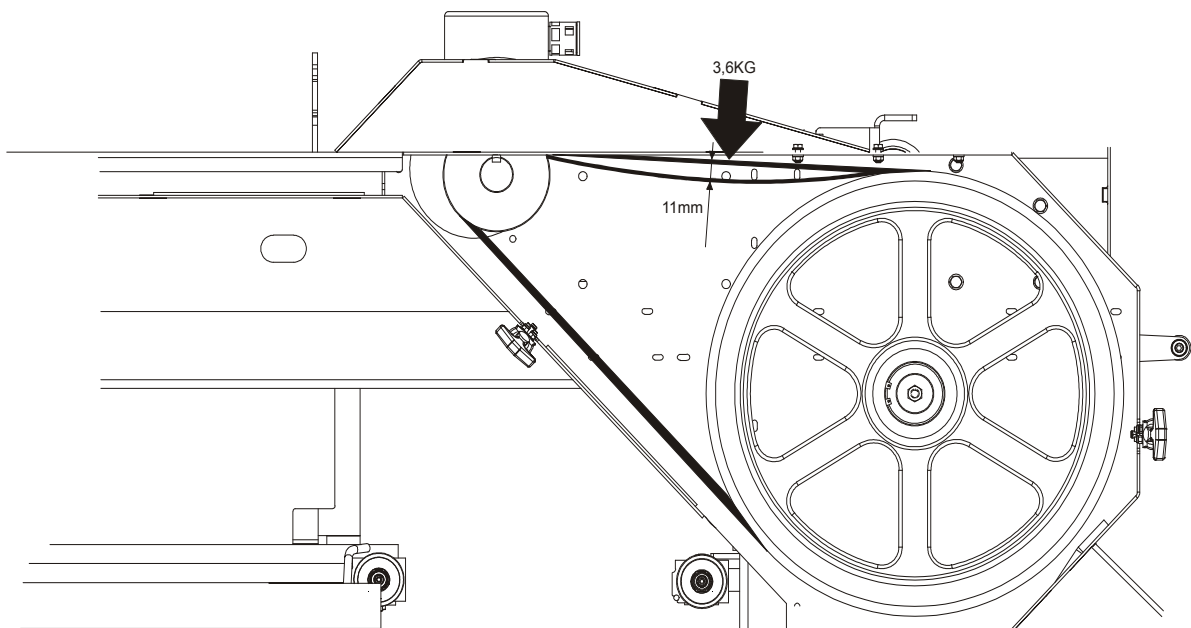
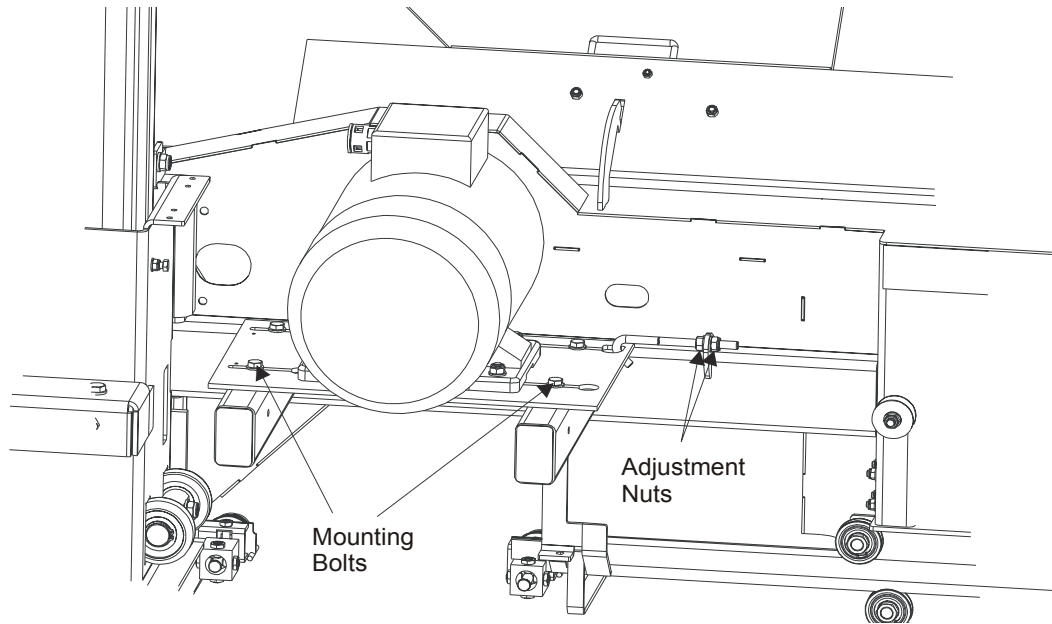

FIG. 3-5

To adjust the drive belt tension:

1. Raise the blade housing cover.
2. Loosen the four mounting bolts in the motor mount plate (See the figure below).
3. Loosen one of the adjustment nuts and using the other one adjust the drive belt(s) tension according to the specifications given in Table 3-2.

4. Tighten the four mounting bolts.



**FIG. 3-6**



Periodically check the belts for wear. Replace if the belt is damaged or worn.

### 3.11 Up/Down System

1. Adjust the up/down chain tension as needed. Measure chain tension with the cutting head all the way to the top of the vertical mast. **Secure the carriage with a chain at the top, or shim it underneath. Using the adjustment nut shown in Figure 3-7, adjust the chain tension** so that there is 1" (2.5 cm) deflection in the center of the chain with a 5 lbs. (2.3 KG) deflection force.



**WARNING!** Always secure the cutting head with a chain or a brace before adjusting the up/down chain. The cutting head may fall, causing severe injury or death.

**See Figure 3-7. Use the adjustment nut shown below to tension the chain.**

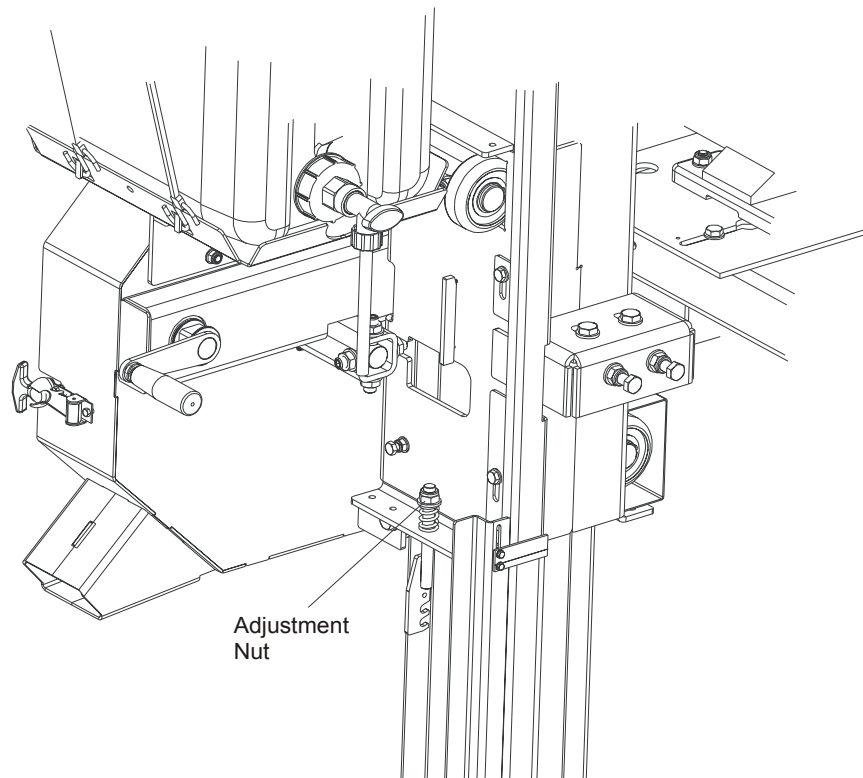

**FIG. 3-7**

2. Adjust the up/down gear belt tension as needed (option).



**WARNING!** Before adjusting, always remove the key from the key switch. Failure to do so may result in serious injury.

3. Loosen the four adjustment bolts shown below. Adjust the belt tension and tighten

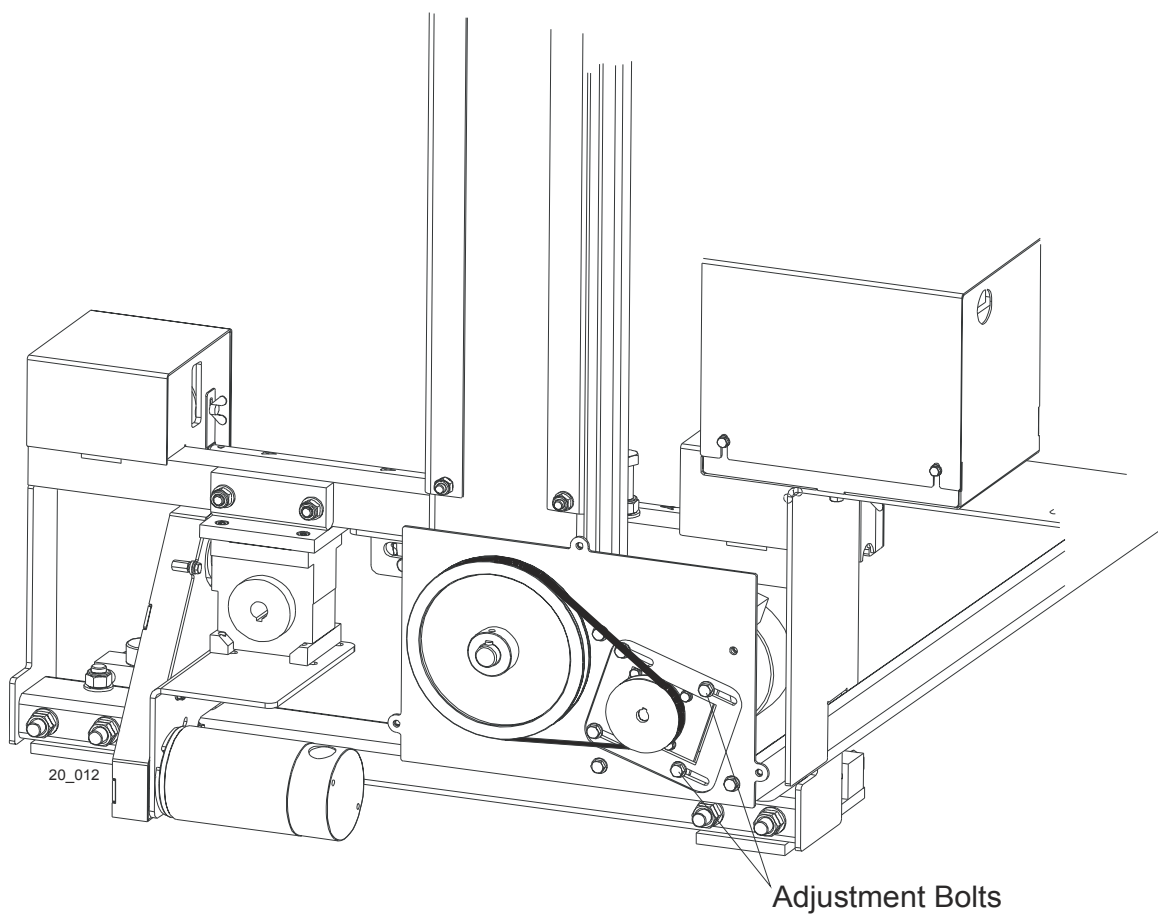

**FIG. 3-8**

the adjustment bolts.

### 3.12 Power Feed System

1. Adjust the power feed chain as needed.



**WARNING!** Always remove the key from the key switch before adjusting the chain. Failure to do so may result in serious injury.

See Figure 3-9. Loosen the sprocket nut. To tighten the chain, move the sprocket to the

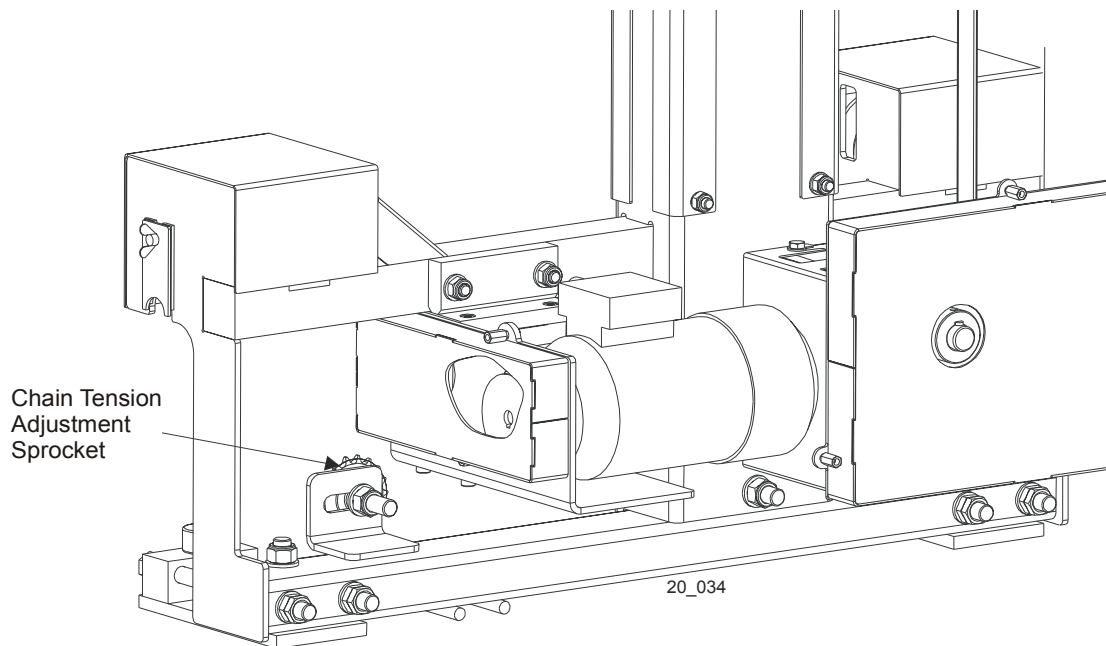

**FIG. 3-9**

left. To loosen the chain, move the sprocket to the right (towards the front end of the mill).

2. If necessary, align the power feed motor pulley with the gear reducer pulley.



**WARNING!** Remove the key from the key switch before adjusting the pulleys. Failure to do so may result in serious injury.

See **Figure 3-10**. Keep the pulleys aligned to avoid premature V-belt and pulleys wear.

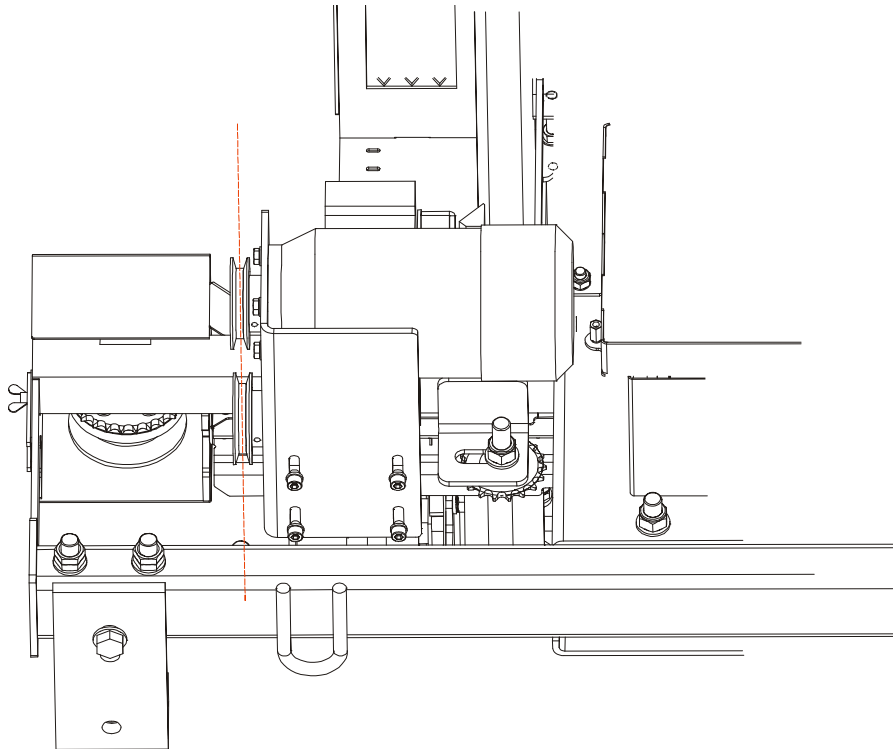

**FIG. 3-10**

To align the pulleys, slide one of them on the shaft appropriately.

3. Adjust the power feed gear belt tension as needed.



**WARNING!** Remove the key from the key switch before adjusting the belt tension. Failure to do so may result in serious injury.

See Figure 3-11. Loosen the adjustment bolts shown below. Adjust the belt tension

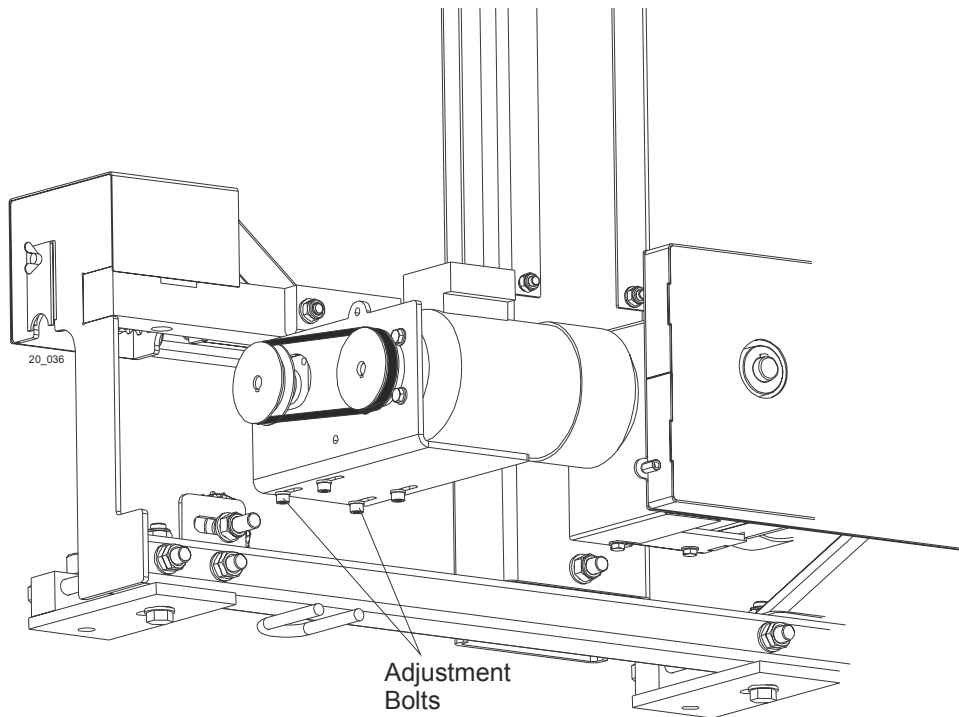

**FIG. 3-11**

and tighten the adjustment bolts.



## SECTION 4 TROUBLESHOOTING GUIDE

### 4.1 Sawing Problems

<b>PROBLEM</b>	<b>CAUSE</b>	<b>SOLUTION</b>
<b>Blades Dull Quickly</b>	Dirty logs	Clean or debark logs, especially on entry side of the cut
	When grinding teeth, heating too much and causing teeth to soften	Grind just enough metal to restore sharpness to the teeth. Use water/coolant while sharpening blade
	Poor sharpening techniques	Make sure the tip is being sharpened completely (See Sharpener Manual)
<b>Blades Break Prematurely</b>	Rubber belts on blade wheels worn to a point that blade contacts metal pulley - look for shiny spots on edge of wheels	Change blade wheel belts (B-57)
	Poor sharpening techniques	See Sharpener Manual
	Tension too tight	Tension blade to recommended specifications
<b>Blade Does Not Track Right on Drive Wheel</b>	Cant adjustment is incorrect	Readjust
	Flat/worn belts	Replace B-57 belts
<b>Blade Guides Do Not Spin While Cutting</b>	Frozen bearings	Replace bearings
	Stiff bearings	Grease bearings
<b>Blade Does Not Stop Immediately After Disengaging</b>	Brake strap too loose	Adjust brake strap
<b>Drive Belts Come Off Pulleys When Disengaging Blade</b>	Brake strap too loose	Adjust brake strap
	Brake drum misaligned	Realign on drive shaft
	Brake strap tightened with one edge too loose and one edge too tight	Adjust brake strap
<b>Drive Belts Wear Prematurely or Jump</b>	Engine/motor and drive pulleys out of alignment	Align pulleys <a href="#">See Section 4.2 Engine/Motor and Drive Pulleys Alignment.</a>

## 4

## Troubleshooting Guide

### Sawing Problems

<b>PROBLEM</b>	<b>CAUSE</b>	<b>SOLUTION</b>
<b>Boards Thick Or Thin On Ends Or Middle Of Board.</b>	Stress in log which causes log to not lay flat on the bed.	After log has been squared, take equal cuts off opposing sides. Take a board off the top. Turn the log 180 degrees. Take a board off. Repeat, keeping the heart in the middle of the cant, and making it your last cut.
	Set in teeth.	Resharpener and reset blade.
	Bed rails misaligned.	Realign sawmill.
<b>Height Adjustment Jumps or Stutters When Moving Up or Down.</b>	Mast needs lubrication.	Lubricate mast track surface.
	Up/down chain improperly adjusted.	Adjust up/down chain.
	Vertical wear pads are too tight.	Adjust pads.
<b>Lumber Is Not Square</b>	Drive belt(s) loose.	Adjust belts.
	Vertical side supports not square to bed	Adjust side supports.
	Blade not parallel to bed rails	Adjust bed rails parallel to blade.
<b>Sawdust Builds Up On Track</b>	Sawdust or bark between cant and bed rails	Remove particles
	Tooth set problems	Resharpener and reset blade
	Excessive oiling	Do not oil track
<b>Wavy Cuts</b>	Track wipers worn	Adjust wipers to firmly contact track
	Track is sticky	Clean track with solvent and apply silicone spray
	Excessive feed	Slow feed rate
	Improperly sharpened blade (This will be the problem 99% of the time!)	Resharpener blade (See Sharpener Manual - read entire manual!)
	Blade guides improperly adjusted	Adjust blade guides.
	Sap buildup on blade	Use Water Lube.
	Tooth set problem	Resharpener and reset blade

## **4.2 Engine/Motor and Drive Pulleys Alignment**

1. Install the drive belt.
2. Use a straight edge to align the engine/motor pulley to the drive pulley. Also check that the engine pulley is within 1/8" square with the drive pulley. Loosen the engine mounting bolts and rotate the engine if necessary.
3. Check front-to-back movement of the engine does not exceed 1/4". Tighten the motor mount U-bolts if necessary.
4. Engage the clutch handle and adjust the drive belt tension to 7/16" deflection with 10 lb. of force.
5. Recheck the pulley alignment and engine squareness with the clutch handle engaged. Adjust if necessary.
6. Adjust the drive belt support to 1/4" ( $\pm 1/32$ ) from the belt while engaged.



## SECTION 5 SAWMILL ALIGNMENT

### 5.1 Pre-Alignment Procedures

The Wood-Mizer sawmill is factory aligned. This section includes instructions on how to realign the sawmill completely. Be scrupulous when performing all alignment steps as sawmill alignment determines the accuracy of your cuts. The alignment procedure should be performed approximately every 1500 hours of operation (sooner if you regularly transport the sawmill over rough terrain).

#### Routine Alignment Procedure:

1. Install and track the blade ([See Section 5.3](#)).
2. Check the angle of the blade in relation to the bed rails and adjust the lower track rollers if necessary ([See Section 5.17](#)).
3. Check and adjust the vertical alignment of the blade guide arm ([See Section 5.6](#)).
4. Check and adjust the horizontal alignment of the blade guide arm ([See Section 5.9](#)).
5. Check and adjust the vertical angle of the blade guides ([See Section 5.12](#)).
6. Check and adjust the horizontal angle of the blade guides ([See Section 5.14](#)).
7. Check and adjust the spacing between the blade guide flanges and the back of the blade ([See Section 5.13](#)).
8. Check and adjust the horizontal angle of the side supports ([See Section 5.15](#)).
9. Check and adjust the vertical angle of the side supports ([See Section 5.16](#)).
10. Check that the blade height scale accurately displays the actual distance from the bottom of the blade to the bed rails and adjust if necessary ([See Section 5.18](#)).

#### Complete Alignment Procedure:

Perform all steps in this section to completely realign the sawmill.

### 5.2 Frame Setup

Stationary sawmills should be setup on firm, level ground before proceeding with alignment.

Portable sawmills should also be setup on firm, level ground.

LT25: Adjust the two middle outriggers on the main frame tube down just enough to lift weight from the trailer tire.

LT25: Adjust the two end outriggers on the main frame tube down just enough to lift weight from the trailer tire.

**All Portable Sawmills:** Adjust the two outer outriggers down just so they touch the ground but do not bear weight.

[See SECTION 2 Setup & Operation](#) for additional setup information.

### 5.3 Blade Installation And Alignment

See **Figure 5-1**. Install a blade and apply the appropriate tension. ([Patrz rozdział 2.5](#)). Blade tension is adjusted with the tension handle shown below.

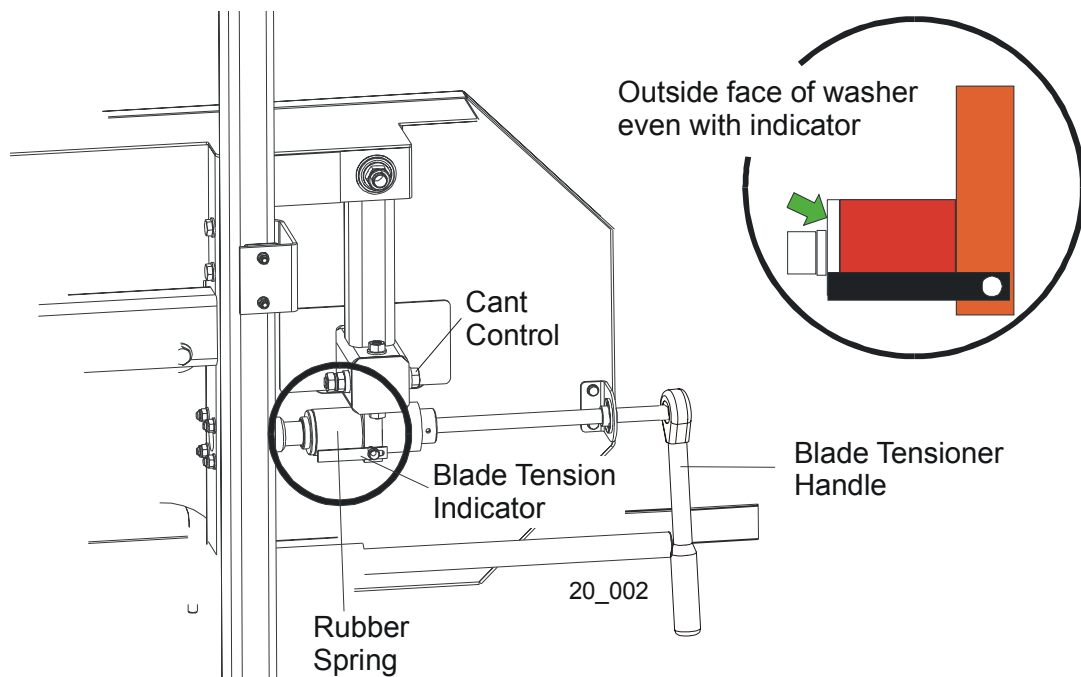

FIG. 5-1

#### Electric Sawmills:

1. Turn the key switch to the "H" position.

(H)

2. Open the blade housing cover.

3. Manually spin one of the blade wheels until the blade positions itself on the blade wheels.

**Gas Sawmills:**

1. Turn the key switch to the "0" position and remove the key.
2. Open the blade housing cover.
3. Release the locking pin. To do this, pull it outward and rotate.
4. Push the clutch lever up lightly so that the locking pin drops down into the hole. At this position of the lever the blade brake is released and the drive belt is loosened.

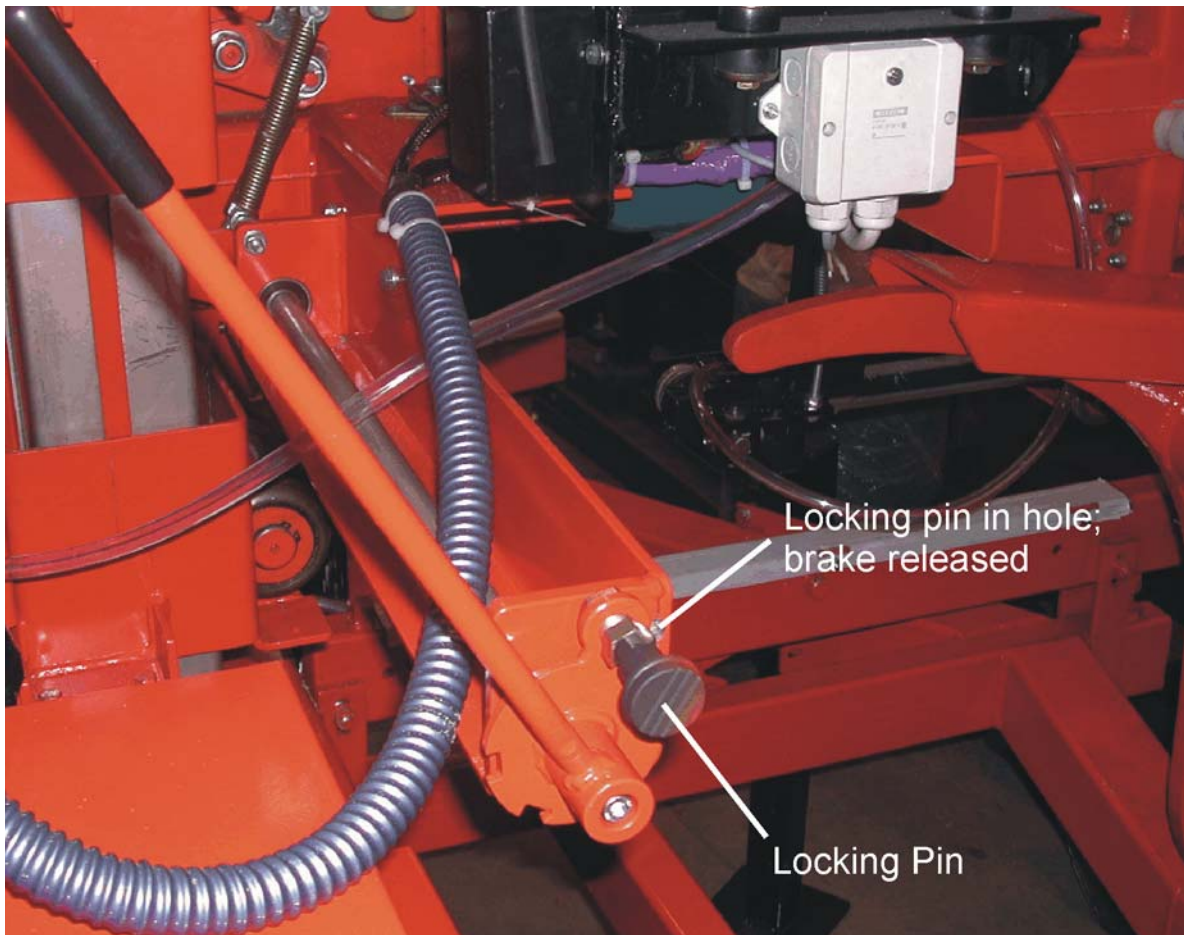

FIG. 5-2

5. Spin one of the blade wheels by hand until the blade positions itself on the blade wheels.

Check the vertical alignment of the idle-side blade wheel. The gullet of the blade should ride the same distance from the front edge of the wheel at the top and bottom of the wheel. If it does not, loosen and tighten the appropriate adjustment screws on the wheel shaft.

## 5 SAWMILL ALIGNMENT

### *Adjusting The Lower Track Rollers*

See **Figure 5-3**. The blade wheels should be adjusted so that the gullet of 1 1/4" blades rides 1/8" (3mm) out from the front edge of the wheels ( $\pm 1/32$  [.75 mm]). The gullet of 1 1/2" blades should ride 3/16" (4.5 mm) from the front edge of the wheels ( $\pm 1/32$  [.75 mm]). Do not let the teeth ride on the belt.

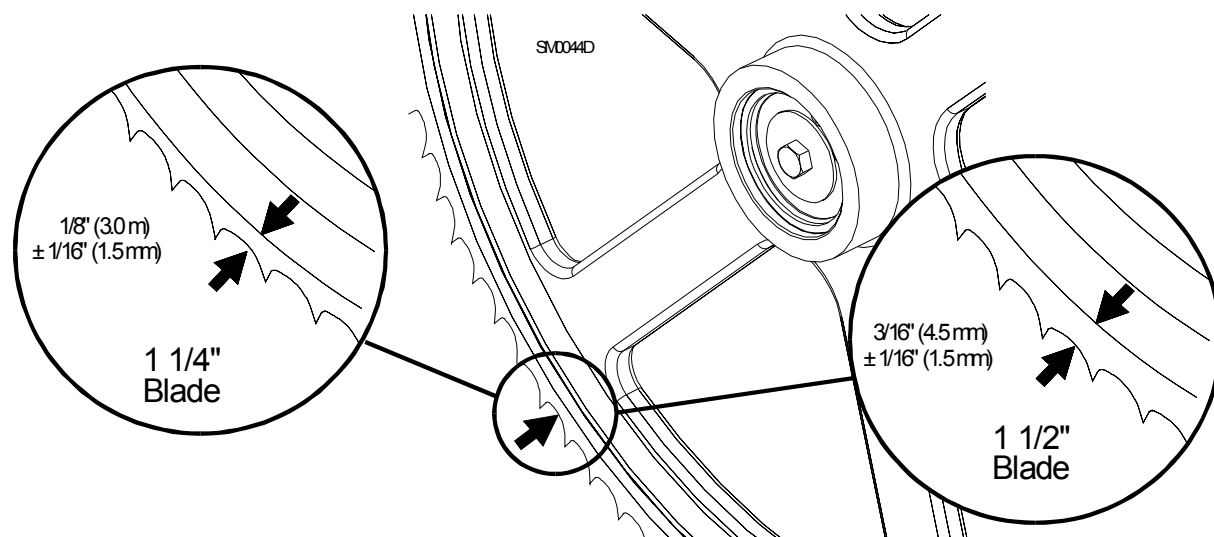

FIG. 5-3

To adjust where the blade travels on the idle-side blade wheel, use the cant control shown in **Figure 5-1**.

To move the blade out on the blade wheel, turn the cant [adjustment screw clockwise](#). To move the blade in on the blade wheel, turn the screw [counterclockwise](#).

Some adjustment in blade tension may be needed to compensate for adjustments made with the cant control.

Adjustment with the cant control is usually all that is required to track the blade properly on both blade wheels. The drive-side blade wheel will usually not have to be adjusted. If necessary, the drive-side wheel can be adjusted as follows:

Locate the nuts and the clamping screws located on the drive-side of the cutting head. If the blade is too far forward on the wheel, turn the screw located on the inside of the head counterclockwise and turn the screw located on the outside of the head clockwise. Make sure to tighten the nuts against the shaft housing when adjustment is complete.

## 5.4 Adjusting The Lower Track Rollers

See **Figure 5-4**. Making these adjustments correctly will give you square cuts and accurate dimensions across the width of your boards.



1. Using the power feed switch, move the saw carriage so that the blade is positioned over the front pivot bed rail.
2. Check the lower rollers. Both rollers should touch the rail so that you cannot spin them by hand. If the rollers are not adjusted evenly and you can spin either one, loosen the stop bolt and adjust the adjustment nuts until the roller cannot be spun by hand. Check the other roller and adjust if necessary. Adjust both rollers until each evenly supports the carriage and you cannot spin either by hand.
3. Move the carriage forward until the blade is positioned over the rear pivot bed rail. Repeat the step #2 until the lower rollers are adjusted properly at the front and rear of the sawmill.

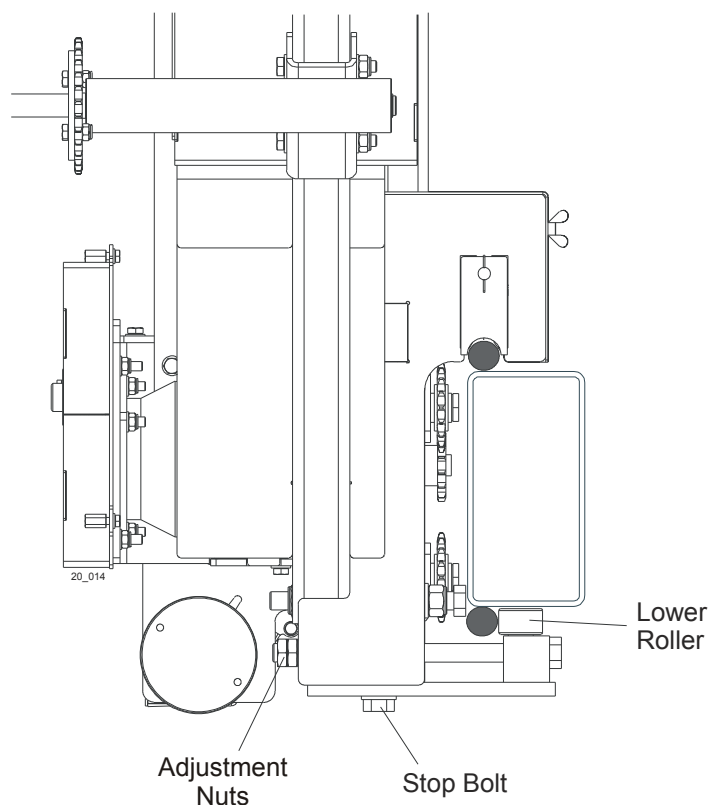

**FIG. 5-4**

4. Remove the blade guides, or adjust them so that they do not touch the blade.
5. Open the adjustable blade guide arm to within 1/2" (15 mm) of full open.
6. Move the carriage back to the front pivot bed rail. Raise the cutting head until the bottom of the blade is 17" (400 mm) above the outside of the pivot rail support by actual measurement with a tape or ruler.

See Figure 5-5.

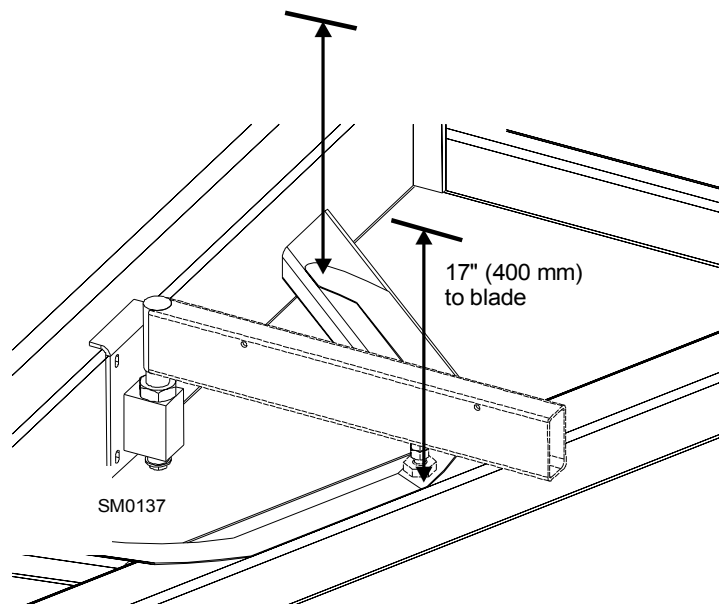

FIG. 5-5

7. Move the carriage forward to check the distance to the blade at the inside of the pivot rail support. Both measurements should be equal within  $1/32$ " (0.8 mm).
8. Using the adjustment nuts adjust the lower rollers to tilt the cutting head until the blade is parallel ( $\pm .016$ ", i.e. 0.4 mm) to the pivot rail support.

**NOTE:** Adjustments of the lower track rollers change the angle between the cutting head and sawmill bed rails. Only small adjustments of the lower track rollers should ever be needed.

9. After the lower track rollers are adjusted properly, adjust the stop screw. Tighten the screw until it touches the main bed tube. Then, back the screw off  $1/2$  turn. The distance from the rail should be  $1/32$ " (0.8mm).



**CAUTION!** It is important that the stop screw is properly adjusted to secure the carriage on the track rails. Failure to properly adjust the stop screw can cause cutting head damage, especially during mill transportation.

See Figure 5-6.

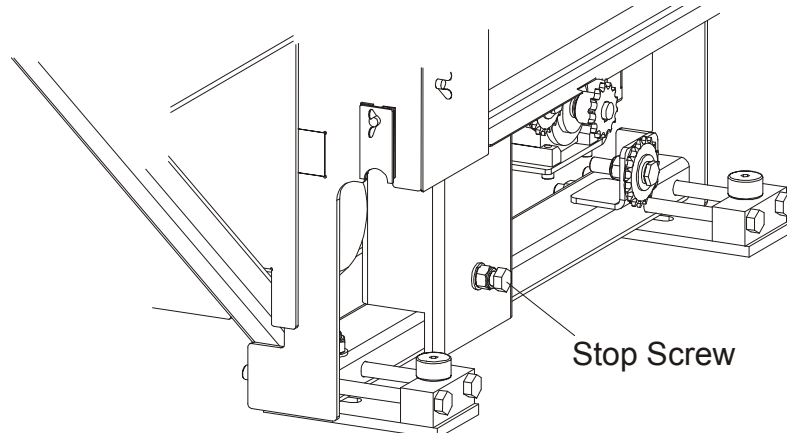

FIG. 5-6

## 5.5 Adjusting Bed Rails To The Blade

1. Adjust the front pivot bed rail 90° to the main bed tube.
2. Move the cutting head to center the blade over the front pivot bed rail.
3. Measure the distance from the top of the pivot rail to the bottom of the blade. Make this measurement at each end of the pivot rail.
4. The two measurements should be 15" (375 mm) ( $\pm 1/32$  [0.8 mm]).
5. Loosen the locking set screws and turn the inner height adjustment nut to adjust the height of the inner end of the pivot rail.

See Figure 5-7.

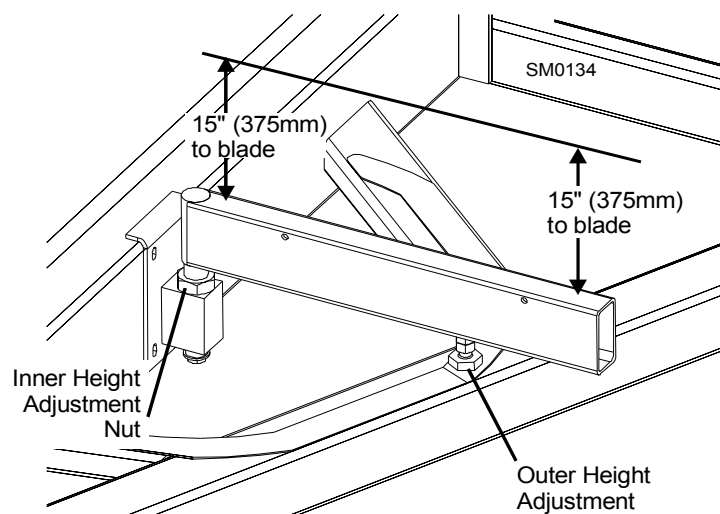

FIG. 5-7

6. Loosen the jam nut and turn the outer height adjustment bolt to adjust the height of the outer end of the pivot rail.
7. Move the cutting head so the blade is positioned over the center of the front main bed rail.
8. Measure the distance between the bottom of the blade and the bed rail at each end of the bed rail. The bed rail should measure 15" (375 mm) (+-1/32 [0.8 mm]) from the blade at each end of the rail.

See Figure 5-8.

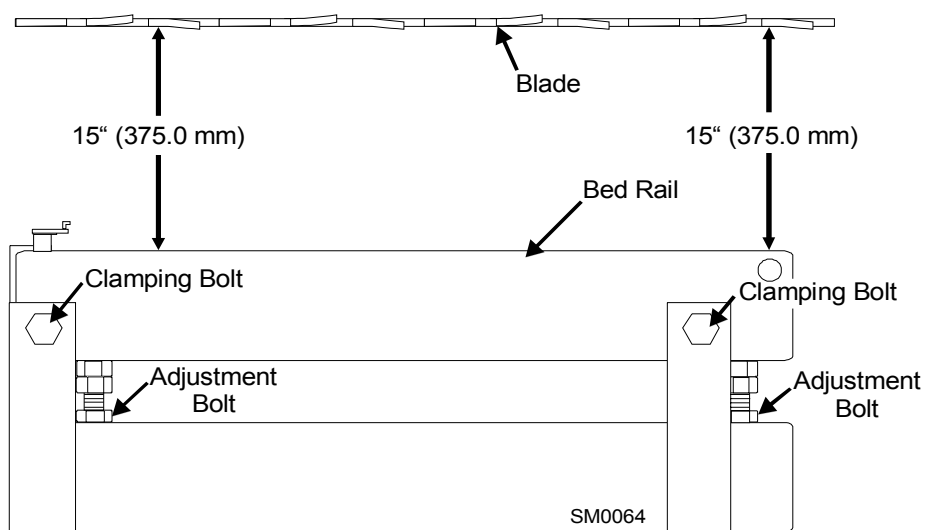

FIG. 5-8

9. Loosen the bed rail clamping bolts and turn the adjustment bolts to move the bed rails to the blade if necessary.
10. Retighten the clamping bolts and adjustment bolts.
11. Without adjusting the cutting head height, check the three remaining main bed rails and the rear pivot rail. Adjust them so that all measure the same distance from the blade at both ends of the bed rail.

## 5.6 Blade Guide Arm Vertical Adjustment

1. Move the cutting head so that the blade guide arm is directly over a bed rail.
2. Adjust the blade guide arm out to within 1/2" (15 mm) of full open.
3. Measure from the top of the bed rail to the arm.

See Figure 5-9.

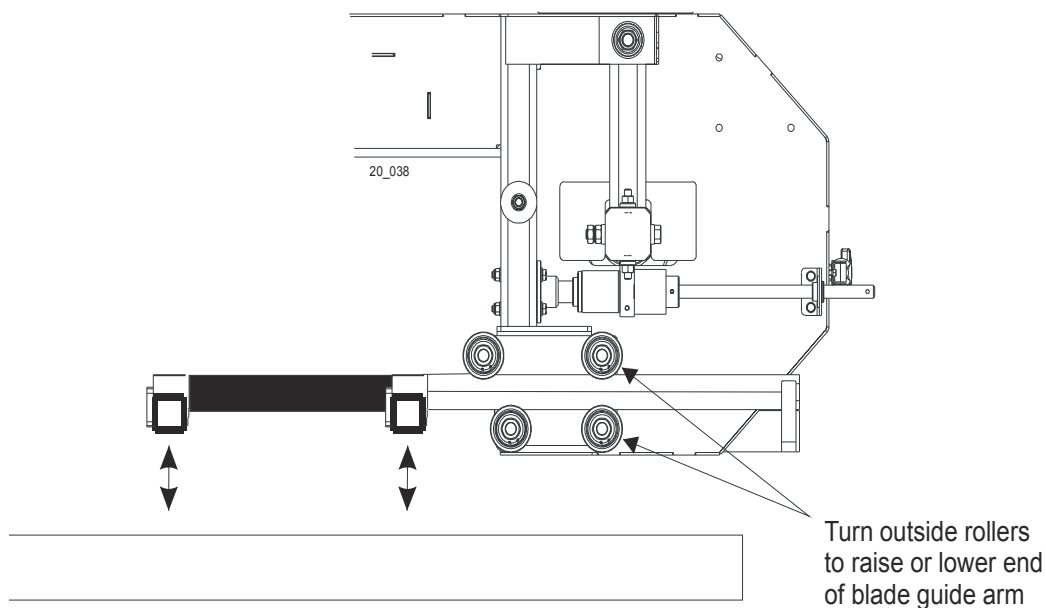

**FIG. 5-9**

4. Adjust the blade guide arm in to within 1/2" (15 mm) of full closed. Measure again from the top of the bed rail to the arm.
5. Adjust the arm so that the measurement from the top of the bed rail to the arm in the closed position is the same as the measurement from the top of the bed rail to the arm in the open position.

If the arm is too low in the closed position, loosen the lower outside roller and tighten the

upper outside roller (See punkt 6.)

If the arm is too high in the closed position, loosen the upper outside roller and tighten the lower outside roller (See punkt 6.)

6. The rollers are mounted on cam bolts that raise or lower the arm when turned.

To adjust the rollers, locate the cam bolt inside the housing and turn until the arm is lowered or raised as needed. Recheck the arm in both the open and closed positions. Repeat adjustments until the arm is the same distance from the bed rail in the open and closed position.

7. The blade guide arm should be snug, but not too tight, in the rollers. You should be able to move it in and out with firm hand pressure. There should be no side-to-side play.

## 5.7 Carriage Backlash Removal

Check the carriage for backlash every 200 hours of operation. If necessary, remove the backlash.

See **Figure 5-10**. To check if the backlash is present, grasp the outside part of the saw

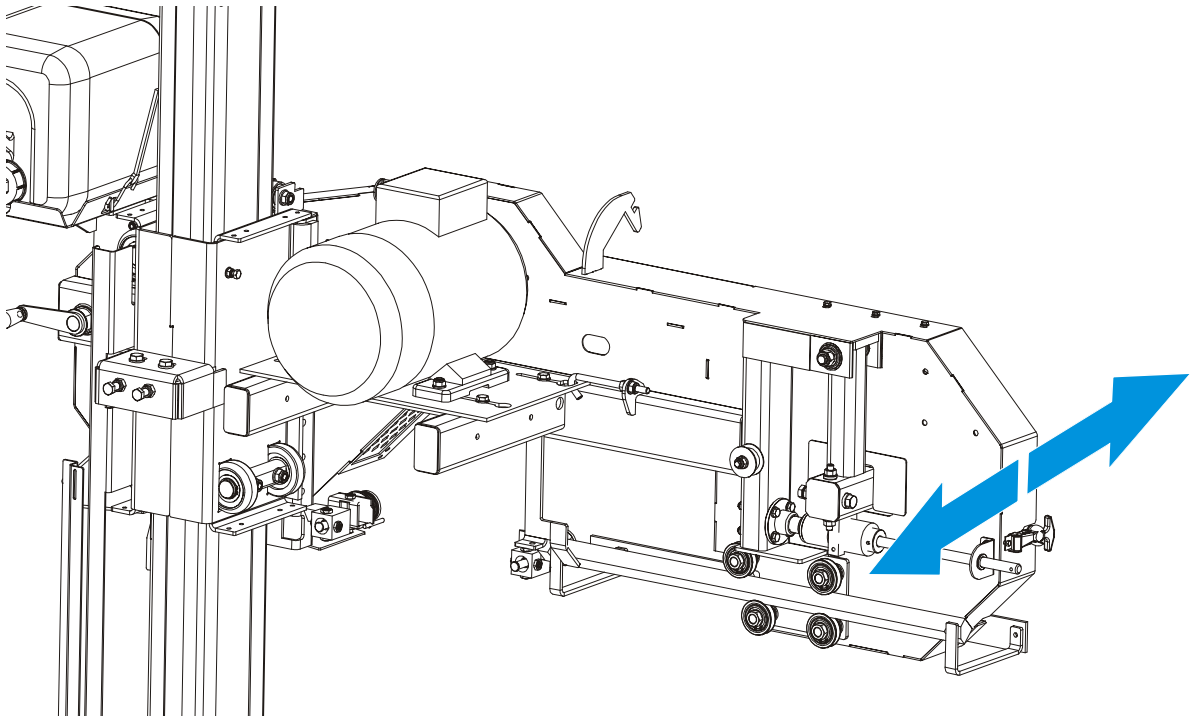

*FIG. 5-10*

head and move it as shown in the figure below. To remove the backlash, perform the following steps:

1. Loosen the nuts on the adjustment bolts and the set screws shown in Figure 5-11.

## 5 SAWMILL ALIGNMENT

### *Carriage Backlash Removal*

2. Tighten the two adjustment bolts evenly to remove the backlash.

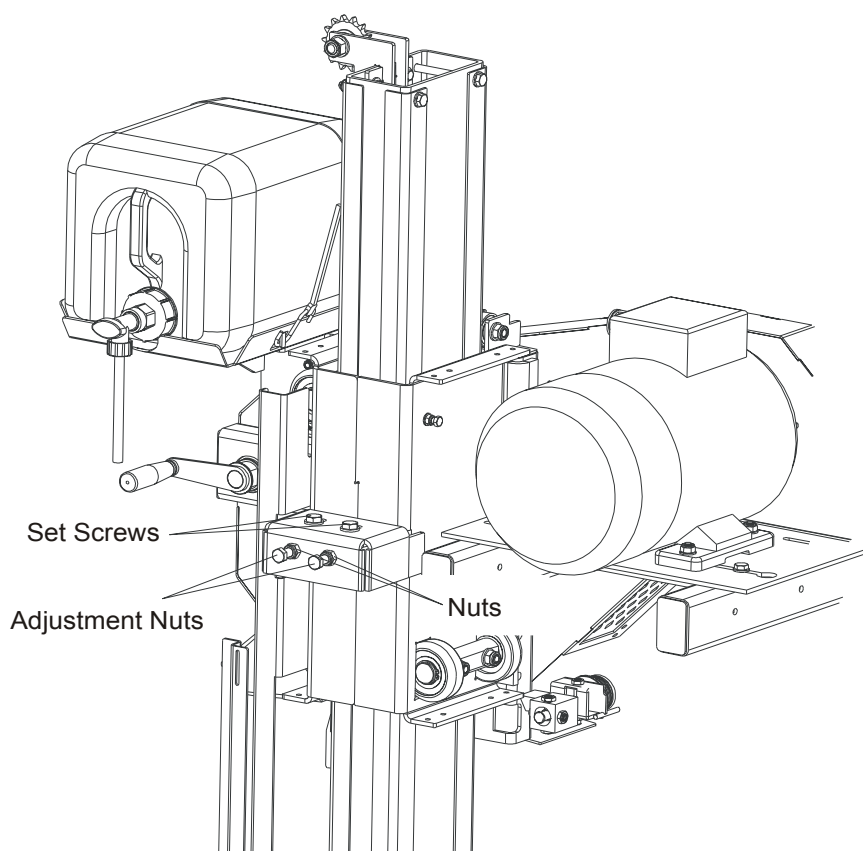

*FIG. 5-11*

3. Tighten the set screws and the nuts.



**CAUTION!** Do not overtighten the adjustment bolts. Damage to the up/down system may result.



## 5.8 Blade Guide Rope Adjustment

Adjust the blade guide rope tension when it gets too loose and begins slipping. To do this, use the adjustment nuts shown in Figure 5-12.

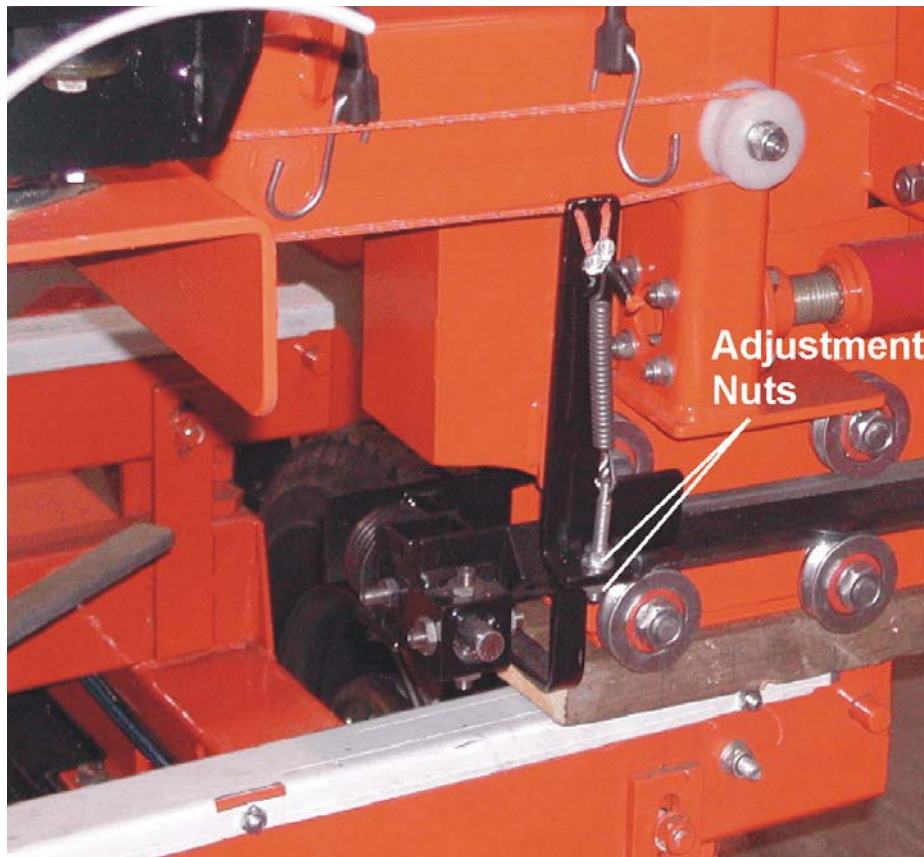
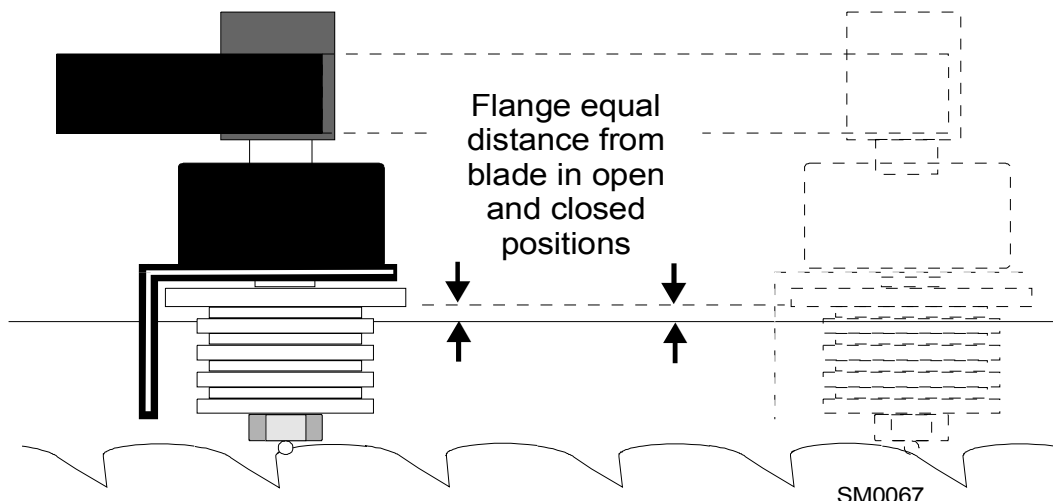

*FIG. 5-12*

## 5.9 Blade Guide Arm Horizontal Adjustment

1. Put the blade guide assembly back in the arm (if you took it out). Put the assembly back so that the flanged collar on the roller is about 1/8" (3.0 mm) from the back of the blade when the arm is 1/2" (15 mm) from full open.
2. Close the throat to within 1/2" (15 mm) from fully closed. Check to see that the flange is the same distance from the back of the blade.

See Figure 5-13.



*FIG. 5-13*

3. If adjustment is needed, the guide rollers can be adjusted in or out on the threaded mounts to open or close the gap.

See Figure 5-14.

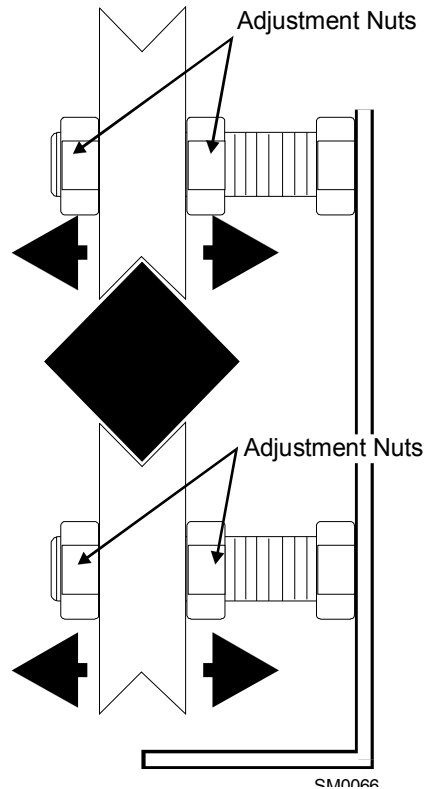

FIG. 5-14

4. Adjusting the outside two rollers (furthest from the arm motor) inward will cause the flange to move away from the blade.
5. Adjusting the two outside rollers outward will cause the flange to move toward the blade.
6. Adjust until the roller flange is the same distance from the back of the blade in the open and closed position.

## 5.10 Aligning the Blade Guides

Each Wood-Mizer sawmill has two blade guide assemblies that help the blade maintain a straight cut. The two blade guide assemblies are positioned on the cutting head to guide the blade on each side of the material being cut.

One blade guide assembly is mounted in a stationary position on the drive side of the cutting head. This assembly is referred to as the "inner" blade guide assembly.

The other blade guide assembly is mounted on the idle side of the cutting head. It is referred to as the "outer" assembly and is adjustable for various widths of materials to be

processed.

Blade guide alignment includes four steps:

- Blade Deflection
- Blade Guide Vertical Tilt
- Blade Guide Flange Spacing
- Blade Guide Horizontal Tilt

Perform the blade guide alignment after you have aligned the blade on the wheels and adjusted the blade and blade guide arm parallel to the bed rails. After blade guide alignment, check the scale indicator to make sure it is adjusted properly ([See Section 5.18](#)).

**NOTE:** During blade guide alignment, remove the blade guide adjusting screws and apply a lubricating oil such as 10W30 or Dexron III to each screw. This will prevent the screws and threaded holes from corroding and make screw adjustments easier.

### 5.11 Blade Deflection

Perform the following steps to achieve proper blade deflection with the blade guides.

1. Raise the carriage until the blade is 15" (375 mm) above a bed rail. Measure the actual distance with a tape from the top of the rail to the bottom of the blade.
2. Install the blade guides. Make sure the two set screws shown are threaded into the blade guide shaft until they touch each other.

See Figure 5-15.

Turn jam nuts to adjust  
roller up or down

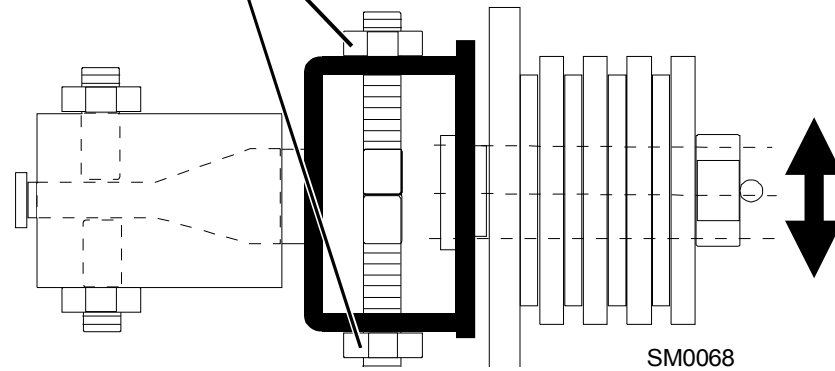

FIG. 5-15

3. Loosen the bottom jam nut and tighten the top jam nut until the blade guide deflects the blade down 1/4" (6.5 mm).
4. Repeat for the other blade guide.

**NOTE:** Be sure that the blade guide touches the blade in both guide assemblies. The outer blade guide should be checked with the arm all the way in and all the way out.

## 5.12 Blade Guide Vertical Tilt Adjustment

Check that the blade guide does not tilt the blade up or down. A Blade Guide Alignment Tool (BGAT) is provided to help you measure the vertical tilt of the blade.

1. Open the blade guide arm 1/2" (15 mm) from full open.
2. Clamp the alignment tool on the blade. Position the tool close to a blade guide roller. Be sure the tool does not rest on a tooth or burr, and is lying flat on the blade.

See Figure 5-16.

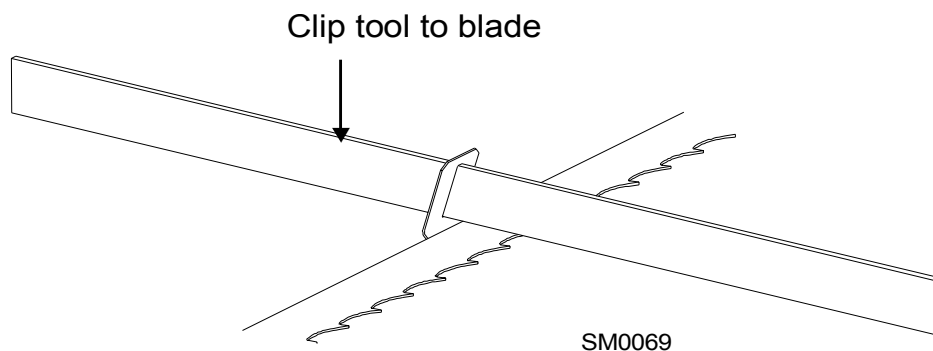

*FIG. 5-16*

3. Measure the distance from the bed rail to the bottom of the tool.

**NOTE:** If the sawmill is equipped with stainless steel bed rail covers, be sure to measure from the blade guide alignment tool to the top surface of the cover rather than the bed rail tube.

4. Move the carriage so that the front end of the tool is positioned above the bed rail.
5. Measure the distance from the bed rail to the bottom edge of the tool.
6. Loosen one set screw at the side of the blade guide assembly.
7. Use the set screws shown to tilt the blade guide until the measurement from the bed rail to the tool equals the first measurement taken at the center of the tool.

See Figure 5-17.

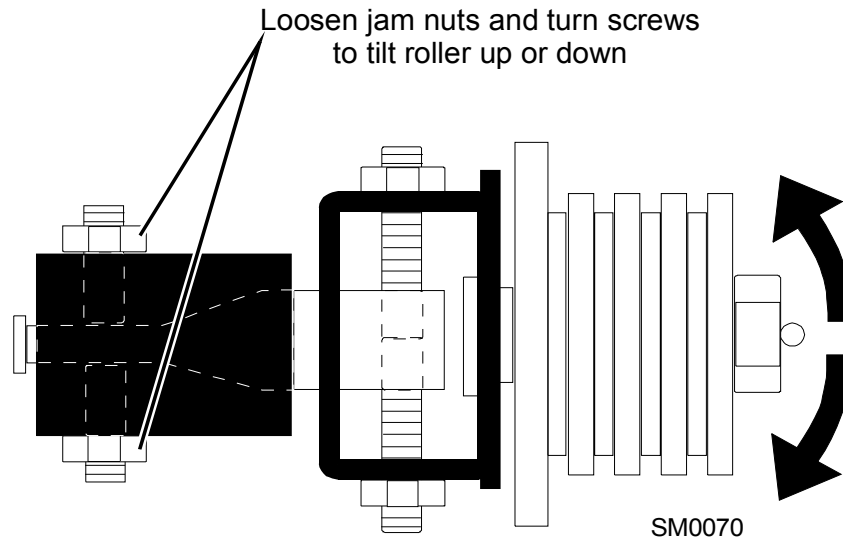

FIG. 5-17

8. Move the carriage forward so the back end of the tool is over the bed rail.
9. Use the set screws shown to adjust the blade guide tilt until the measurement from the bed rail to the tool equals the other two measurements taken.
10. Move the tool close to the other blade guide and repeat the previous steps.

**NOTE:** If major adjustments to blade guide tilt were made, measure the distance between the blade and the bed rails again to ensure the correct 1/4" (6.5 mm) blade guide deflection. Adjust if necessary.

### 5.13 Blade Guide Spacing

**HINT:** When adjusting blade guide spacing, loosen the top set screw and one side set screw only. This will ensure horizontal and vertical tilt adjustments are maintained when the set screws are retightened.

1. Adjust the inner blade guide so the blade guide flange is approximately 1/16"-1/8" (1.5 – 3.0 mm) from the back of the blade.
2. Loosen one side and one top set screw shown. Tap the blade guide forward or backward until properly positioned.

## 5 SAWMILL ALIGNMENT

### *Horizontal Tilt Adjustment*

See Figure 5-18.

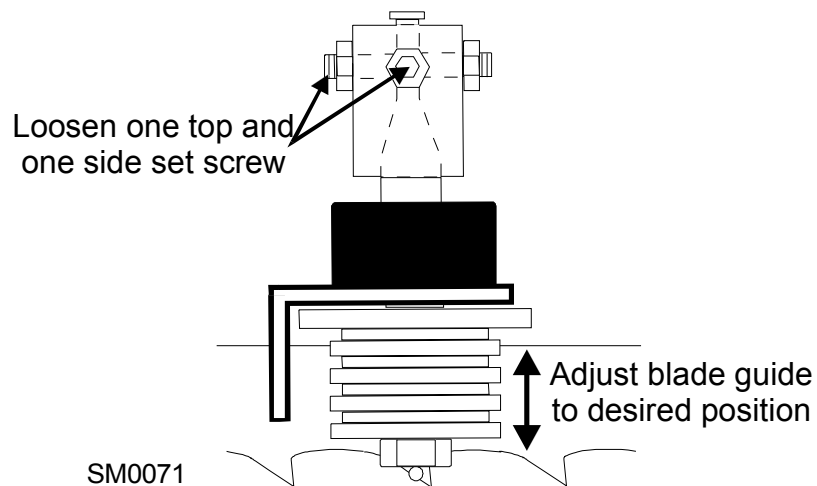

*FIG. 5-18*

3. Retighten the two set screws.
4. Adjust the outer blade guide in the same way so the blade guide flange is approximately 1/16"-1/8" (1.5 – 3.0 mm) from the back of the blade.

### 5.14 Horizontal Tilt Adjustment

1. Finally, both blade guides must be tilted horizontally. Adjust the blade guide arm halfway in.



See Figure 5-19.

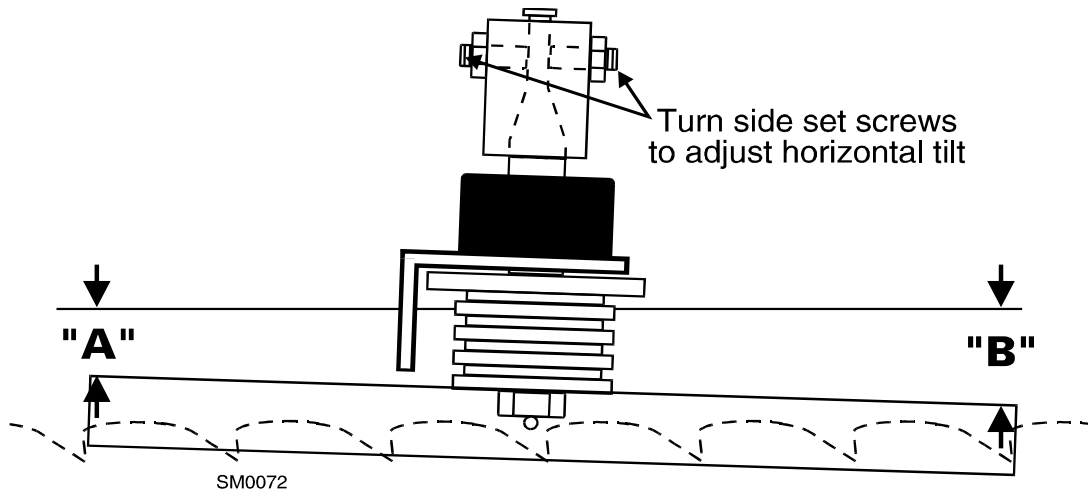

FIG. 5-19

2. Place the Blade Guide Alignment Tool against the face of the outer blade guide roller.
3. Center the tool on the roller and measure between the back edge of the blade and the ruler at the end closest to the inner blade guide ("B").
4. Measure between the back edge of the blade and the other end of the ruler ("A").
5. The roller should be parallel to the blade ( $A=B$ ) or tilted slightly to the left ( $A=B-1.4$ " [6 mm]).
6. Use the side set screws to adjust the horizontal tilt of the roller.
7. Repeat steps 3-7 for the inner blade guide roller.

**NOTE:** Once the blade guides have been adjusted, any cutting variances are most likely caused by the blade. See the **Blade Handbook, Form #600**.

### 5.15 Horizontal Adjustment of Side Supports

Logs and boards are clamped against the side supports when sawing. The sides supports must be square to the bed to ensure square lumber.

1. Swing the side support down.
2. Measure between the face of the support and the main bed tube. Make measurements at both ends of the side support to make sure that it is parallel to the rail.

See Figure 5-20.

3. Use the two lower bolts to adjust the side support so  $B=A$  or  $+1/32"$  (0.8 mm).
4. Repeat for remaining side supports.

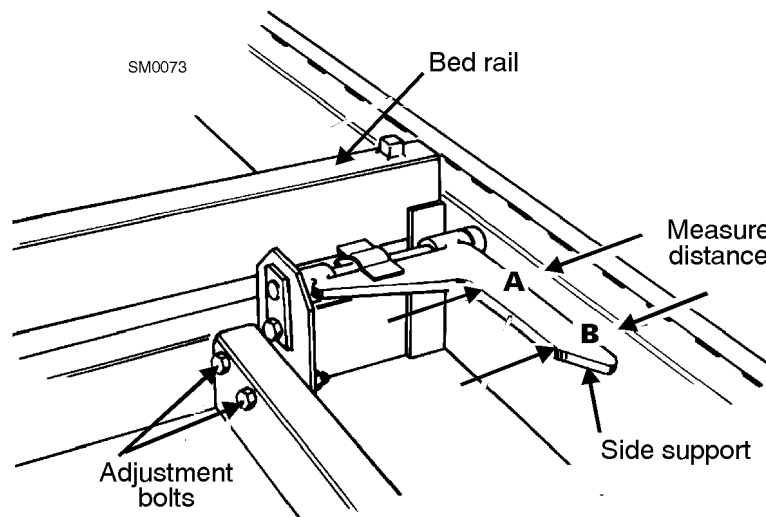

FIG. 5-20

### 5.16 Vertical Adjustment of Side Supports

1. Place a flat board across the bed rails.
2. Swing a side support up so that it is vertical.
3. Pull back at the top of the support to eliminate slack as if a log were being clamped against it.

See Figure 5-21.

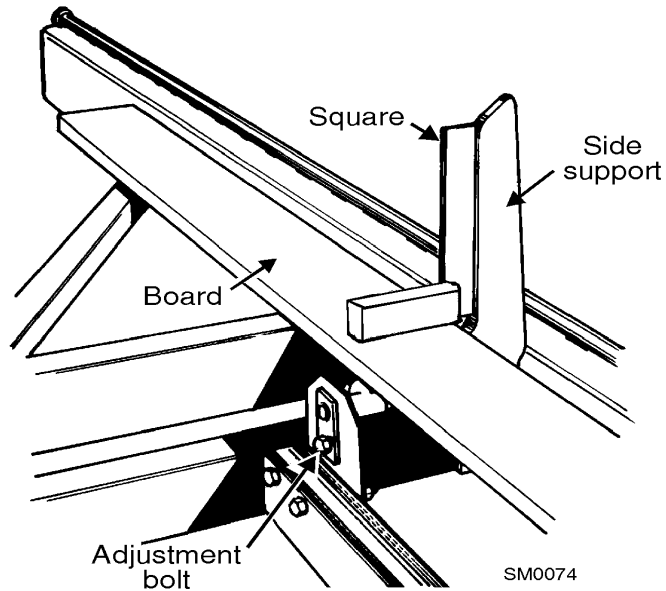

FIG. 5-21

4. Check the angle of each support with a square on the board.
5. The side support should be  $90^\circ$  to the bed rails or leaning forward  $1/32"$  (0.8 mm). Loosen the top adjustment bolt, adjust the side support, and retighten the bolt.
6. Repeat for the remaining side supports.

## 5.17 Saw Head Tilt

As the blade enters a wide log or cant, the outside of the saw head will drop down slightly. To compensate for the drop, use the lower track roller horizontal nuts to raise the outside of the saw head  $1/16"$  (1.5 mm).

1. Move the cutting head so the blade is positioned  $14 \frac{3}{4}"$  (375 mm) above a bed rail.
2. Adjust the lower track roller horizontal nuts until the blade measures  $14 \frac{13}{16}"$  (376.5 mm) from the bed rail near the outer blade guide.

See Figure 5-22.

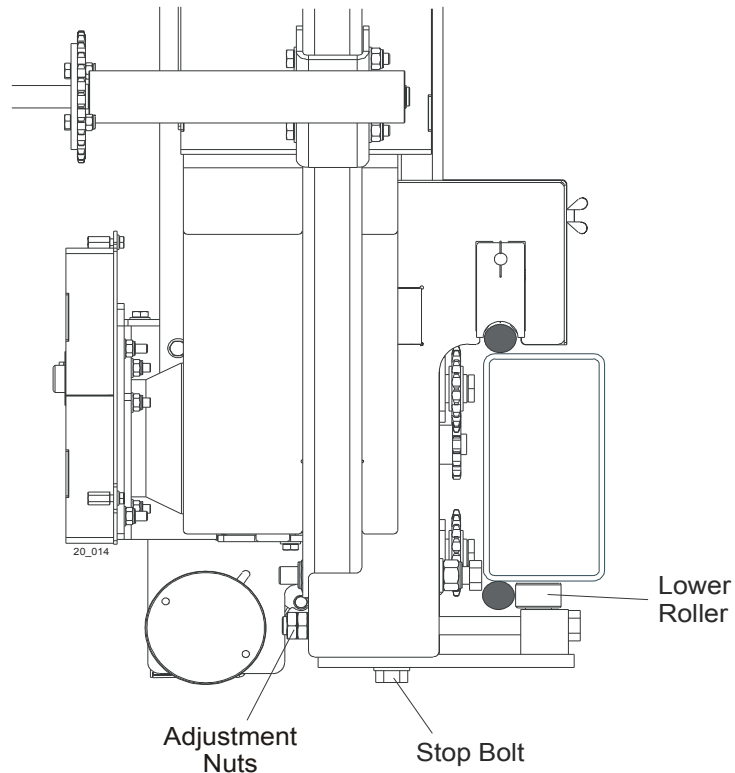

FIG. 5-22

## 5.18 Blade Height Scale Adjustment

After the entire sawmill has been aligned and all adjustments made, check that the blade height scale indicates the true distance from the blade to the bed rails.

1. Move the saw head so the blade is positioned directly above one of the bed rails. Measure from the bottom edge on a down-set tooth of the blade to the top of the bed rail (or stainless steel sleeve if applicable).

See Figure 5-23.

2. View the blade height scale with eyes level with the indicator.

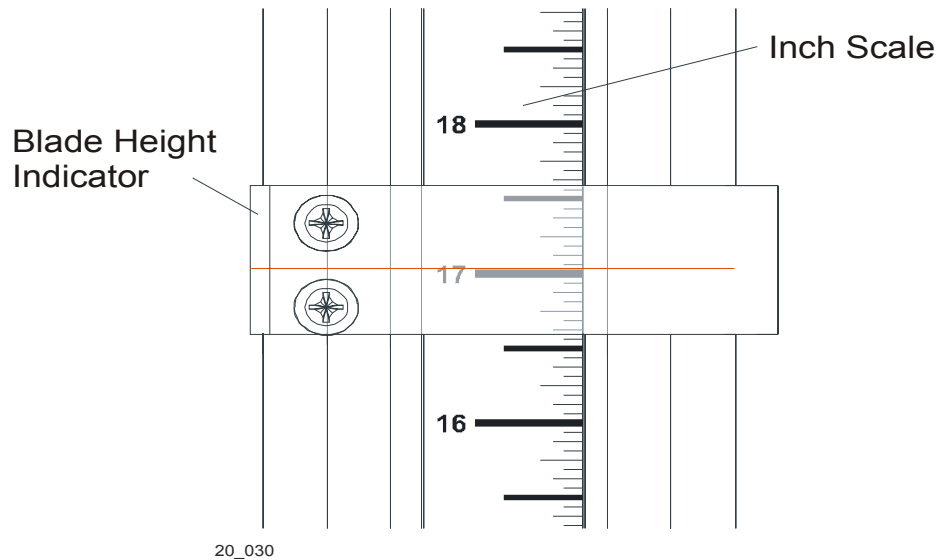

FIG. 5-23

3. Loosen the indicator bracket mounting bolts and adjust the bracket until the indicator is aligned with the correct mark on the scale (+0 -1/32 [0.8 mm]). Retighten the bracket mounting bolts.

For example, if the measurement from blade to bed rail was 14 3/4" (375 mm), make sure the indicator reads 14 3/4" (375 mm) on the scale.

