

Wood-Mizer G24 Gasoline Option

LT30 rev. C6.00

LT40 rev. C6.00

LT30HD rev. C7.00

LT40HD rev. C7.00

Operator's Manual

March 1997

Form #612

Table of Contents

Section-Page

SECTION 1	SAFETY & GENERAL INFORMATION	1-1
1.1	Refueling	1-1
1.2	Engine Operation.....	1-2
1.3	Battery Handling	1-3
SECTION 2	OPERATION	2-1
2.1	Starting The Engine.....	2-1
SECTION 3	MAINTENANCE	3-1
3.1	Air Filter & Pre-Cleaner	3-1
3.2	Fuel Filter	3-2
3.3	Battery	3-2
3.4	Miscellaneous Maintenance	3-2
3.5	Drive Belt Adjustment.....	3-3
3.6	RPM Adjustments	3-5
3.7	Alternator Belt.....	3-7
SECTION 4	REPLACEMENT PARTS	4-1
4.1	How To Use The Parts List	4-1
4.2	Sample Assembly	4-1
4.3	Fuel Tank Assembly.....	4-2
4.4	Engine Assembly.....	4-3
SECTION 5	ELECTRICAL INFORMATION	5-1
5.1	Electrical Symbol Diagram, G24 LT30/LT40.....	5-1
5.2	Electrical Symbol Diagram, G24 LT30HD/LT40HD	5-2
5.3	Electrical Components, G24 LT30/LT40.....	5-3
5.4	Battery Specifications, G24 LT30/LT40.....	5-3
5.5	Electrical Components, G24 LT30HD/LT40HD	5-4
5.6	Battery Specifications, G24 LT30HD/LT40HD	5-4
5.7	Wiring Diagram, G24 LT30/LT40	5-5
5.8	Wiring Diagram, G24 LT30HD/LT40HD	5-6

SECTION 1 SAFETY & GENERAL INFORMATION



IMPORTANT! This manual is provided as a supplement to the equipment manufacturer's manuals. This manual takes into account the specific use of engines on the Wood-Mizer sawmill. Only safety, maintenance, and operating procedures that are not provided by the manufacturer are supplied in this manual. Refer to the manufacturer's manual before attempting to operate this equipment.



This symbol calls your attention to instructions concerning your personal safety. Be sure to observe and follow these instructions. This symbol accompanies a signal word. The word **DANGER** indicates an imminently hazardous situation which, if not avoided, will result in death or serious injury. **WARNING** suggests a potentially hazardous situation which, if not avoided, could result in death or serious injury. **CAUTION** refers to potentially hazardous situations which, if not avoided, may result in minor or moderate injury to persons or equipment. Read all safety instructions before operating this equipment and observe all safety warnings!

1.1 Refueling



WARNING! Store gasoline away from sawdust and other flammable materials. Failure to do so may result in serious injury.

1 Safety & General Information

Engine Operation

1.2 Engine Operation



DANGER! Always be sure the blade is disengaged and all persons are out of the path of the blade before starting the engine or motor. Failure to do so will result in serious injury.



WARNING! Remove the blade before performing any engine service. Failure to do so may result in serious injury.

WARNING! Always wear proper and necessary safety equipment when performing service functions. Proper safety equipment includes eye protection, breathing protection, hand protection and foot protection.

WARNING! Do not for any reason adjust the engine drive belts or belt support bracket with the engine running. Doing so may result in serious injury.

WARNING! Do not operate engine without proper and operational spark arrester/muffler. Sparks emitted from the engine exhaust could ignite surrounding materials, causing severe injury or death.

WARNING! Be sure the power feed switch is in the neutral position before turning the key switch to the on (#1) or accessory (#3) position. This prevents accidental carriage movement, which may cause serious injury or death.



IMPORTANT! Always dispose of coolant, oil, fuel, oil filters and fuel filters in a responsible manner and in conformance with local, state and federal regulations.

1.3 Battery Handling



DANGER! Batteries expel explosive gases. Keep sparks, flames, burning cigarettes, or other ignition sources away at all times. Always wear safety goggles and a face shield when working near batteries. Failure to do so will cause serious injury.¹



WARNING! Charge the battery in a well ventilated area. Do not attempt to charge a frozen battery.

WARNING! Use extreme care to avoid spilling or splashing electrolyte (which is dilute sulfuric acid) as it can destroy clothing and burn the skin. If electrolyte is spilled or splashed on clothing or the body, it should be neutralized immediately and then rinsed with clean water. A solution of baking soda, or household ammonia, and water may be used as a neutralizer.

Electrolyte splashed into the eyes is extremely dangerous. If this should happen, force the eye open and flood it with cool, clean water for approximately fifteen minutes. A doctor should be called immediately when the accident occurs and “on-the-spot” medical attention given if possible. If a doctor cannot come to the scene of the accident immediately, follow his instructions concerning actions to take. Do not add eye drops or other medication unless advised to do so by the doctor. Do not place a battery or acid within the reach of children. If acid (electrolyte) is taken internally drink large quantities of water or milk. Follow with milk of magnesia, beaten egg or vegetable oil. Call a physician immediately.

If electrolyte is spilled or splashed on any surface of the car, it should be neutralized and rinsed with clean water.¹

1. Battery Council International, copyright 1987

SECTION 2 OPERATION

2.1 Starting The Engine

Engine Control Lights

See **Figure 2-1**. The following indicator lights are located on the sawmill control panel.



Alternator Charge Indicator: Lights up if the alternator is not charging the battery.



Key Switch Indicator: Lights up when the key is in either the on (#1) or accessory (#3) position.

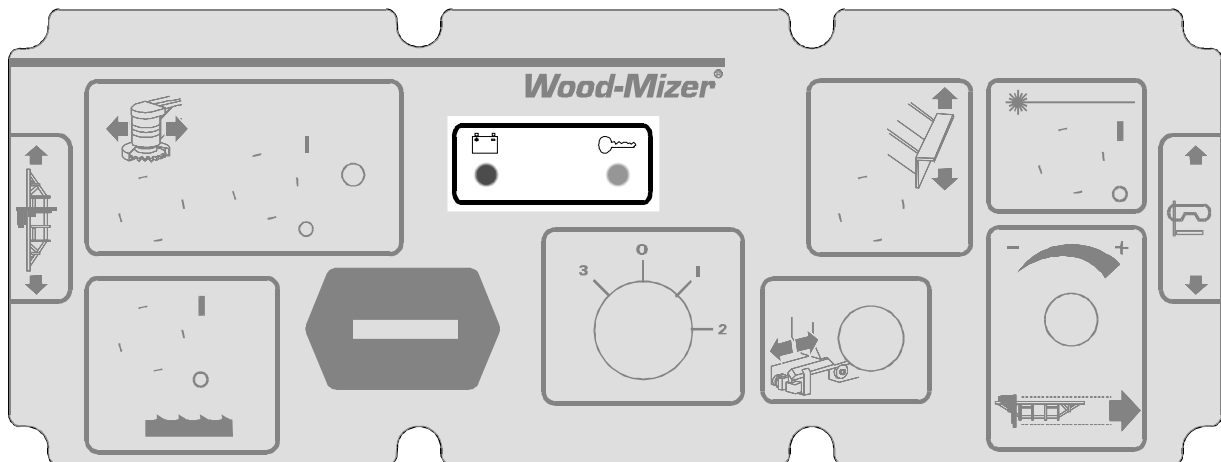

FIG. 2-1

2 **Operation** *Starting The Engine*

Engine Start

DANGER! Always be sure the blade is disengaged and all persons are out of the path of the blade before starting the engine or motor. Failure to do so will result in serious injury.

WARNING! Be sure the power feed switch is in the neutral position before turning the key switch to the on (#1) or accessory (#3) position. This prevents accidental carriage movement, which may cause serious injury or death.

Turn the key switch to the start (#2) position and release.

If the engine needs choking to start, pull the choke wire out until the engine starts. Push the choke wire in after the engine starts.

For more information, see the engine manufacturer's operation manual.

If the fuel tank was recently filled or replaced, squeeze the primer bulb once or twice before trying to start the engine. **NOTE:** If pumping problems are experienced, make sure the out-flow end of the hose line is connected to the fuel filter. If pumping problems are still experienced, hold the primer bulb in a vertical position while squeezing. This allows the fuel check valve to operate properly.

Engine Shutoff

Turn the key switch to the off (#0) position.

SECTION 3 MAINTENANCE



IMPORTANT! This manual only provides information about additional procedures or procedures to be performed at different time intervals than found in the engine manufacturer's manuals. Refer to the manufacturer's manual for complete maintenance instructions.



WARNING! Remove the blade before performing any engine service. Failure to do so may result in serious injury.



This symbol identifies the interval (hours of operation) at which each maintenance procedure should be performed. "AR" signifies maintenance procedures which should be performed as required.

3.1 Air Filter & Pre-Cleaner



WARNING! Always wear proper and necessary safety equipment when performing service functions. Proper safety equipment includes eye protection, breathing protection, hand protection and foot protection.



Service the pre-cleaner every four hours of operation. Service by gently shaking excess sawdust and debris from the foam piece.



Clean the air filter (air cleaner element) and pre-cleaner (element wrapper) every eight hours of operation. See the engine manual for further instructions.



Replace the pre-cleaner (element wrapper) every 2000 hours of operation.

3 Maintenance

Fuel Filter

3.2 Fuel Filter



Replace the fuel filter every 100 hours of operation.

3.3 Battery



Check the battery electrolyte level every 50 hours of operation. See manufacturer's manual for instructions.



DANGER! Batteries expel explosive gases. Keep sparks, flames, burning cigarettes, or other ignition sources away at all times. Always wear safety goggles and a face shield when working near batteries. Failure to do so will cause serious injury.¹

3.4 Miscellaneous Maintenance



Clean and inspect the spark arresters every 50 hours of operation. Replace if damaged.



Inspect the spark plugs every 100 hours of operation. Remove any deposits and adjust gap if necessary. See engine manual for further information.

1. Battery Council International, copyright 1987

3.5 Drive Belt Adjustment



WARNING! Do not for any reason adjust the engine drive belts or belt support bracket with the engine running. Doing so may result in serious injury.



Check the drive belt tension after the first 20 hours, and every 50 hours thereafter. When engaged, the drive belt should have 7/16" (11 mm) deflection with a 8 lb. deflection force.

To adjust the drive belt:

1. Remove the two belt covers located underneath the engine.
2. Loosen the drive belt turnbuckle jam nuts. Turn the turnbuckle counterclockwise (as viewed from the top) to tighten the belts, clockwise to loosen the belts.

See Figure 3-1.

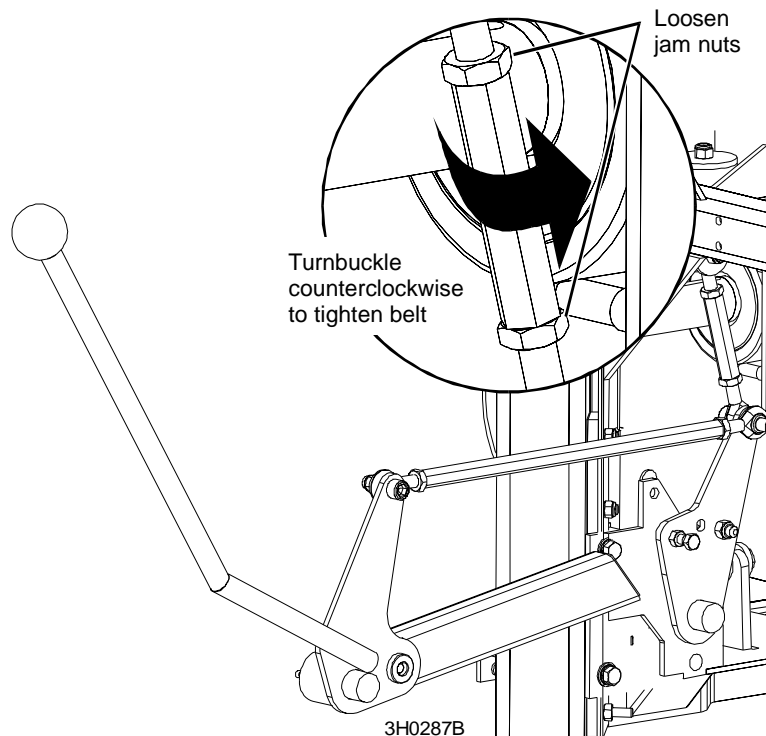

FIG. 3-1



Periodically check all belts for wear. Replace any damaged or worn belts as needed.

3

Maintenance

Drive Belt Adjustment



Adjust the drive belt support as needed. The drive belt support is designed to extend belt life. The support bracket should be adjusted to NOT touch the drive belt when the clutch handle is engaged (down position), AND to hold the drive belt away from the engine pulley when the clutch handle is disengaged (up position).

See Figure 3-2. To adjust:

1. Make sure the motor is not running. Loosen the adjustment bolt.
2. Position the support bracket so it does not touch the drive belt with the clutch handle engaged, and does hold the drive belt away from the motor pulley with the clutch handle disengaged.
3. Retighten the adjustment bolt to 25-27 pound feet (34-37 newton meters).

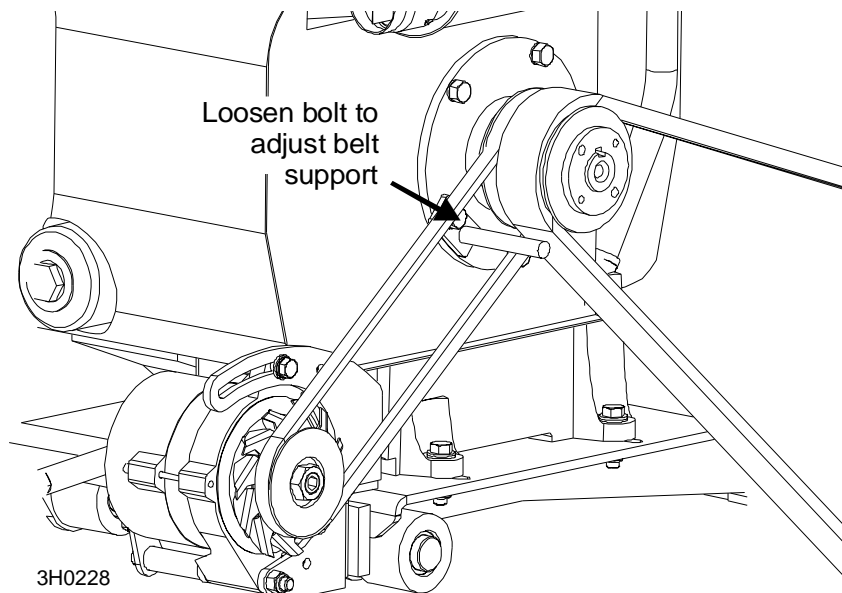

FIG. 3-2

3.6 RPM Adjustments



WARNING! Remove the blade before performing any engine service. Failure to do so may result in serious injury.



Check the RPM with a tachometer after the first 20 hours of operation and every 200 hours thereafter. High-end RPM should be 3400-3600RPM and low-end RPM should be 1800 (± 100).

Before checking the RPM, make sure belt and brake strap tension are correct (See Saw-mill Maintenance).

1. Start the engine to measure the low-end RPM.

Make sure that the throttle linkage is not affecting the engine RPM while the clutch/brake handle is disengaged. Make sure the cable is not bent or kinked. If necessary, rotate the clamp on bracket B until the cable spring, cable guide, cable, and throttle brackets are aligned. **NOTE:** It is important that the above components are aligned. Proper alignment allows any slack in the cable (when engine is idling) to slide down into the cable spring. This maintains free operation of the cable and prevents the cable from kinking. Make sure the shoulder bolt does not rub against the crankcase vent tube.

2. Refer to the engine manual to adjust the low-end RPM.
3. Engage the clutch handle to throttle the engine and measure the high-end RPM.

3

Maintenance

RPM Adjustments

See Figure 3-3. To adjust the high-end RPM, lower or raise the cable guide in the throttle cable bracket until the cable spring extends 1/4" - 3/8" (6.4 - 9.5 mm) when the engine is at 3400-3600 RPM. Bend the high speed stop on bracket B down until it touches bracket A. This will prevent over-revving the engine when tightening the belt adjustment. To adjust for low-end RPM, adjust the idle screw on bracket B until the RPM is 1800 (± 100). **NOTE:** A properly adjusted throttle will extend the cable spring 1/4" to 3/8" (6.4 - 9.5 mm) when running and have a slight amount of slack in the cable when idling.

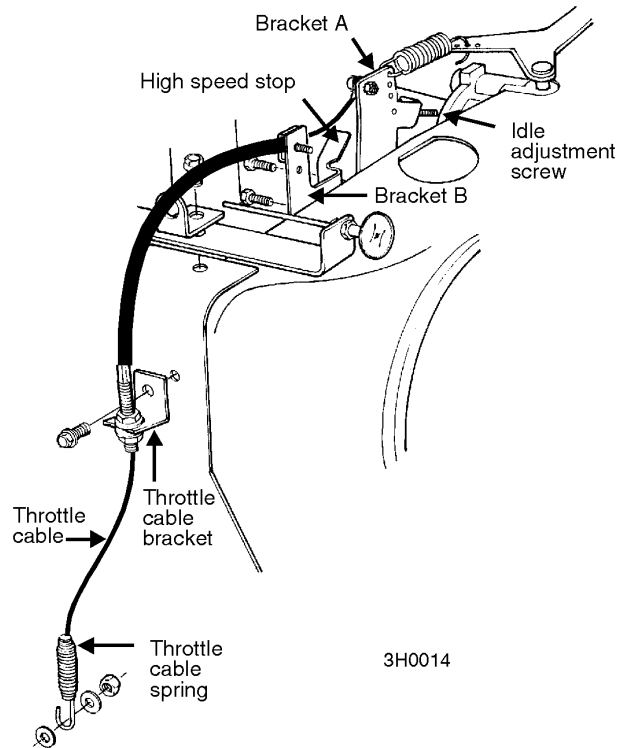

FIG. 3-3

3.7 Alternator Belt



Adjust the alternator belt as needed. Check the alternator belt for tension and wear when battery is not charging properly or when the alternator belt is squealing. To tighten the belt, loosen the adjustment bolt and lock washer. Pivot the alternator away from the motor until the belt has 7/16" (11 mm) deflection with a 5 lb. deflection force. Retighten the adjustment bolt.

See Figure 3-4.

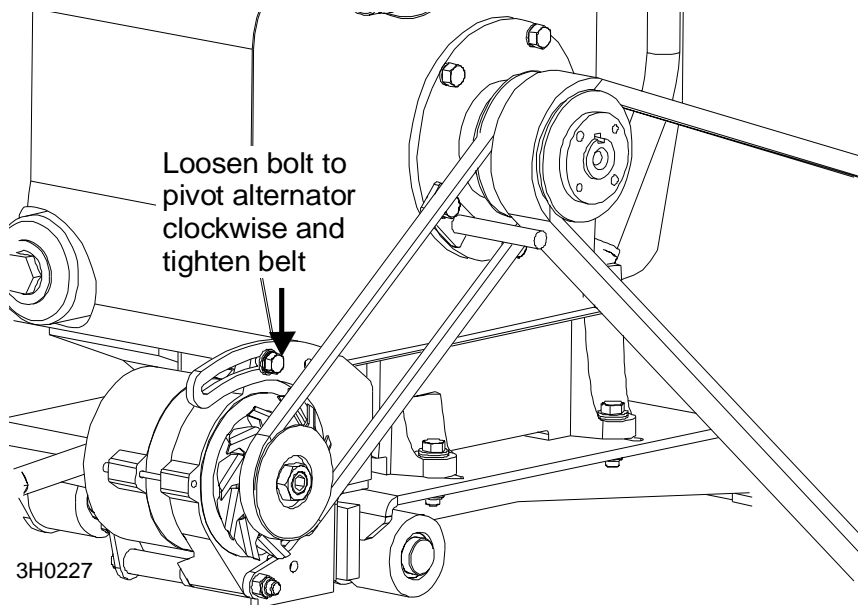

FIG. 3-4

SECTION 4 REPLACEMENT PARTS

4.1 How To Use The Parts List

- Use the table of contents or the index to locate the assembly that contains the part you need.
- Go to the appropriate section and locate the part in the illustration.
- Use the number pointing to the part to locate the correct part number and description in the table.
- Parts shown indented under another part are included with that part.
- Parts marked with a diamond (◆) are only available in the assembly listed above the part.

See the sample table below. Sample Part #A01111 includes part F02222-2 and subassembly A03333. Subassembly A03333 includes part S04444-4 and subassembly K05555. The diamond (◆) indicates that S04444-4 is not available except in subassembly A03333. Subassembly K05555 includes parts M06666 and F07777-77. The diamond (◆) indicates M06666 is not available except in subassembly K05555.

4.2 Sample Assembly				
REF	DESCRIPTION (◆ Indicates Parts Available In Assemblies Only)	PART #	QTY.	
	SAMPLE ASSEMBLY, COMPLETE (INCLUDES ALL INDENTED PARTS BELOW)	A01111	1	
4	Sample Part	F02222-22	1	
	Sample Subassembly (Includes All Indented Parts Below)	A03333	1	
5	Sample Part (◆ Indicates Part Is Only Available With A03333)	S04444-4	1	◆
	Sample Subassembly (Includes All Indented Parts Below)	K05555	1	
6	Sample Part (◆ Indicates Part Is Only Available With K05555)	M06666	2	◆
7	Sample Part	F07777-77	1	

To Order Parts:

- From Europe call our European Headquarters and Manufacturing Facility in Kolo, Poland at **+48-63-2610233** or **+48-3912-1319**. From the continental U.S., call **1-800-448-7881** to order parts. Have your customer number, vehicle identification number, and part numbers ready when you call.
- From other international locations, contact the Wood-Mizer distributor in your area for parts.

4 Replacement Parts

Fuel Tank Assembly

4.3 Fuel Tank Assembly

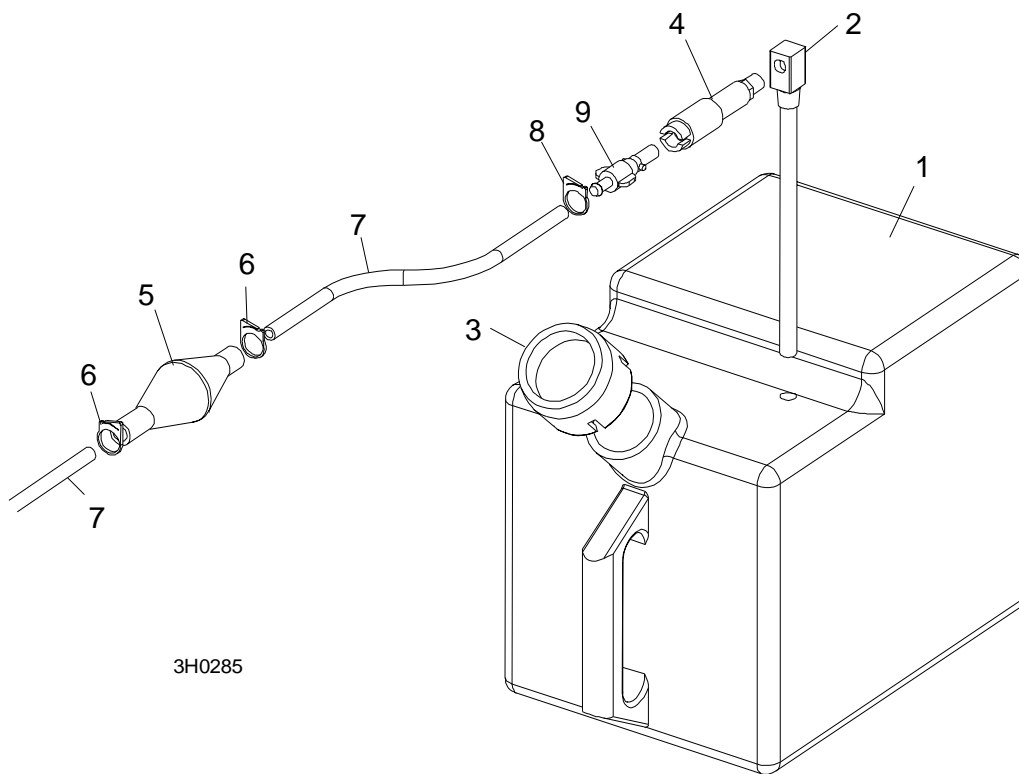

3H0285

REF	DESCRIPTION (◆ Indicates Parts Available In Assemblies Only)	PART #	QTY.	
	TANK ASSEMBLY, 5-GALLON RED GASOLINE	A12285	1	
1	Tank, 5-Gallon Red Fuel	P12167	1	◆
2	Pickup, 9" Fuel	P12172	1	
3	Cap, 3 or 5-Gallon Fuel Tank	P09683	1	
4	Fitting, 1/4" NPT Plastic Female Disconnect	P12175	1	
	HOSE, FUEL LINE WITH PRIMER BULB	014497	1	
	Bulb Kit, Fuel Primer Replacement	014496	1	
5	Bulb, Fuel Primer	014481	1	◆
6	Clamp, 1/2" OD Plastic Hose	P12374	2	
	Instruction Sheet, Fuel Primer Bulb Replacement	014496-590	1	
7	Hose, 1/4" ID Fuel	R01890-1	2 m	
8	Clamp, 1/2" OD Plastic Hose	P12374	1	
9	FITTING, 1/4" NPT PLASTIC MALE DISCONNECT	P12176 ¹	1	

¹ Replacement requires qty. 1 hose clamp (P12374).

4.4 Engine Assembly

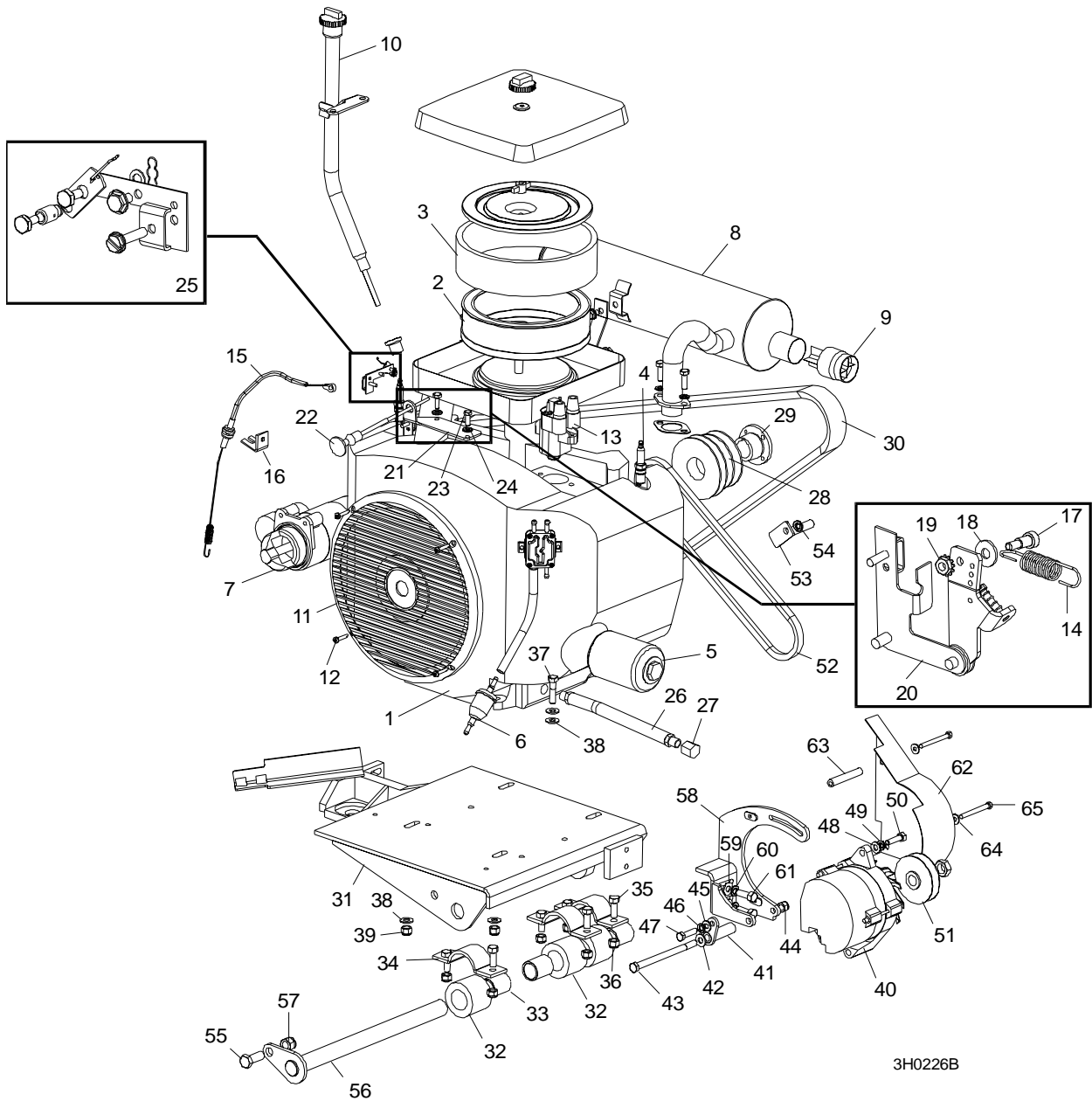

3H0226B

REF	DESCRIPTION (◆ Indicates Parts Available In Assemblies Only)	PART #	QTY.	
	ENGINE ASSEMBLY, 24HP ONAN P224G	A11631	1	
1	Engine, 24Hp Onan P224 (See Form #202.fm for complete list of engine parts)	P11463	1	◆
2	Filter, Onan 20/24Hp Air	P07566	1	
3	Pre-Cleaner, Onan 20/24Hp Air	P07961	1	

4

Replacement Parts

Engine Assembly

4	Plug, Onan Spark (Champion #RS14YC)	P06819	2	
5	Filter, Onan 24Hp Oil	P09881	1	
6	Filter, In-Line Fuel	P07570	1	
7	Starter Motor, Onan	P06830	1	
	Muffler Retrofit, P224 Onan 24Hp Single	K12372	1	
	Muffler Replacement Kit, P224 Onan 24HP	K12746	1	
8	Muffler, Onan 24Hp Single-Type #541-0315	P12369	1	◆
9	Spark Arrester, Onan 24HP Single-Type #155-2429-05	P12370	1	
10	Oil Fill, Extended W/Dipstick Replacement	P12371	1	
	Instruction Sheet, Onan P224 Muffler Upgrade	K12372-135	1	
11	Guard, Onan P224G Engine	P11936	1	
12	Screw, #10-24 X 1" Phillips Head Type 23	F05015-27	4	
13	Coil, Onan P224 Ignition	P06827	1	
14	Spring, Onan Governor	P04497	1	
	Spring, Onan Governor Surge Control	014541	1	
	Cables Retro, Onan Throttle and Front Pull Choke	K12913	1	
15	Cable, Onan 24hp Throttle	P12313	1	
16	Bracket, Throttle Cable Mount	S12312	1	
17	Bolt, 1/4" x 3/8" Shoulder (#10-24 Thread)	F05004-57	1	
18	Washer, 1/4" SAE Flat	F05011-11	1	
19	Nut, #10-24 Self-Locking	F05010-14	1	
20	Linkage Assembly, 24HP P224 Onan Throttle	P12329	1	
	Nut, 1/4-20 Self-Locking (for shipping purposes only)	F05010-9	2	
	Instruction Sheet, Onan Throttle Upgrade	K12913-418	1	
	Upgrade Kit, Onan Rear to Front Pull Choke	K12953	1	
21	Bracket, Front Pull Choke	085938-1	1	
22	Wire, Onan Front Pull Choke	P12916	1	
23	Bolt, 1/4-20 x 3/4" Hex Head Full Thread	F05005-1	2	
24	Washer, 1/4" Split Lock	F05011-14	2	
25	Linkage Assembly, 24HP P224 Onan Choke	P12952	1	
	Instruction Sheet, Onan Choke Upgrade	K12953-446	1	
26	Hose, 7" Oil Drain	P10082	1	
27	Cap, Oil Drain 3/8" Pipe	P04332	1	
	Oil, 15W40 Shell Helix	083560	2 l	◆
28	Pulley, 3-Groove Motor	S10435	1	
	Key, 1/4" X 1/4" X 1 1/4"	S04124	1	
29	Bushing, 1 1/8" Split Taper	P04306	1	
30	BELT, 2BX74 DRIVE	P10277-2	1	
31	PLATE, MOTOR MOUNT	014514	1	
	BUSHING ASSEMBLY, MOTOR MOUNT PIVOT	A04127	2	
32	Bushing, Rubber Motor Mount Pivot	P12164	1	
33	Spacer, Motor Mount Pivot	P05041	1	
34	CLAMP WELDMENT , MOTOR MOUNT PIVOT BUSHING	014540	3	

35	BOLT, 3/8-16 X 1" HEX HEAD	F05007-7	3	
36	NUT, 3/8-16 HEX NYLON LOCK	F05010-10	6	
37	BOLT, 3/8-16 X 1 1/2" HEX HEAD GRADE 2	F05007-3	4	
38	WASHER, 3/8" SAE FLAT	F05011-3	12	
39	NUT, 3/8-16 HEX NYLON LOCK	F05010-10	4	
	KIT, ALTERNATOR WITH BRACE	K12801	1	
40	Alternator, 61 Amp Delco	P03804	1	
41	Brace, Alternator	W12761	1	
42	Washer, 3/8" SAE Flat	F05011-3	1	
43	Bolt, 3/8-16 x 5 1/2" Hex Head Full Thread	F05007-34	1	
44	Nut, 3/8-16 Hex Nylon Lock	F05010-10	1	
45	Washer, 5/16" SAE Flat	F05011-17	1	
46	Washer, 5/16" Split Lock	F05011-13	1	
47	Bolt, M8 X 1.25" X 1" Hex Head Full Thread	F05004-40	1	
48	WASHER, 5/16" SAE FLAT	F05011-17	1	
49	WASHER, 5/16" SPLIT LOCK	F05011-13	1	
50	BOLT, M8 X 1.25" X 1" HEX HEAD FULL THREAD	F05004-40	1	
51	PULLEY, 1979452 DELCO ALTERNATOR	P03806	1	
52	BELT, A36 ALTERNATOR	085754	1	
	BRACKET ASSEMBLY, DRIVE BELT SUPPORT SINGLE-PRONG	A12243	1	
53	Bracket, Drive Belt Support Single-Prong	W12237	1	◆
54	Washer, 3/8" Split Lock	F05011-4	1	
	Instruction Sheet, Drive Belt Support Single-Prong	A12243-420	1	
55	BOLT, 1/2-13 X 1 1/4" HEX HEAD GRADE 5	F05008-37	1	
56	PIN WELDMENT, ENGINE MOUNT PIVOT	014154	1	
57	NUT, 1/2-13 NYLON LOCK	F05010-8	1	
58	BRACKET, ALTERNATOR MOUNT	014509	1	
59	WASHER, 3/8" SAE FLAT	F05011-3	2	
60	WASHER, 3/8" SPLIT LOCK	F05011-4	2	
61	BOLT, 3/8-16 X 1" HEX HEAD	F05007-7	2	
62	GUARD, ALTERNATOR BELT	014499	1	
63	SPACER, 5/16" X 7/16" X 1 15/16" TUBE	014424	1	
64	WASHER, 1/4" SAE FLAT	F05011-11	2	
65	BOLT, 1/4-20 X 2 1/4" HEX HEAD	F05005-7	2	

SECTION 5 ELECTRICAL INFORMATION

5.1 Electrical Symbol Diagram, G24 LT30/LT40

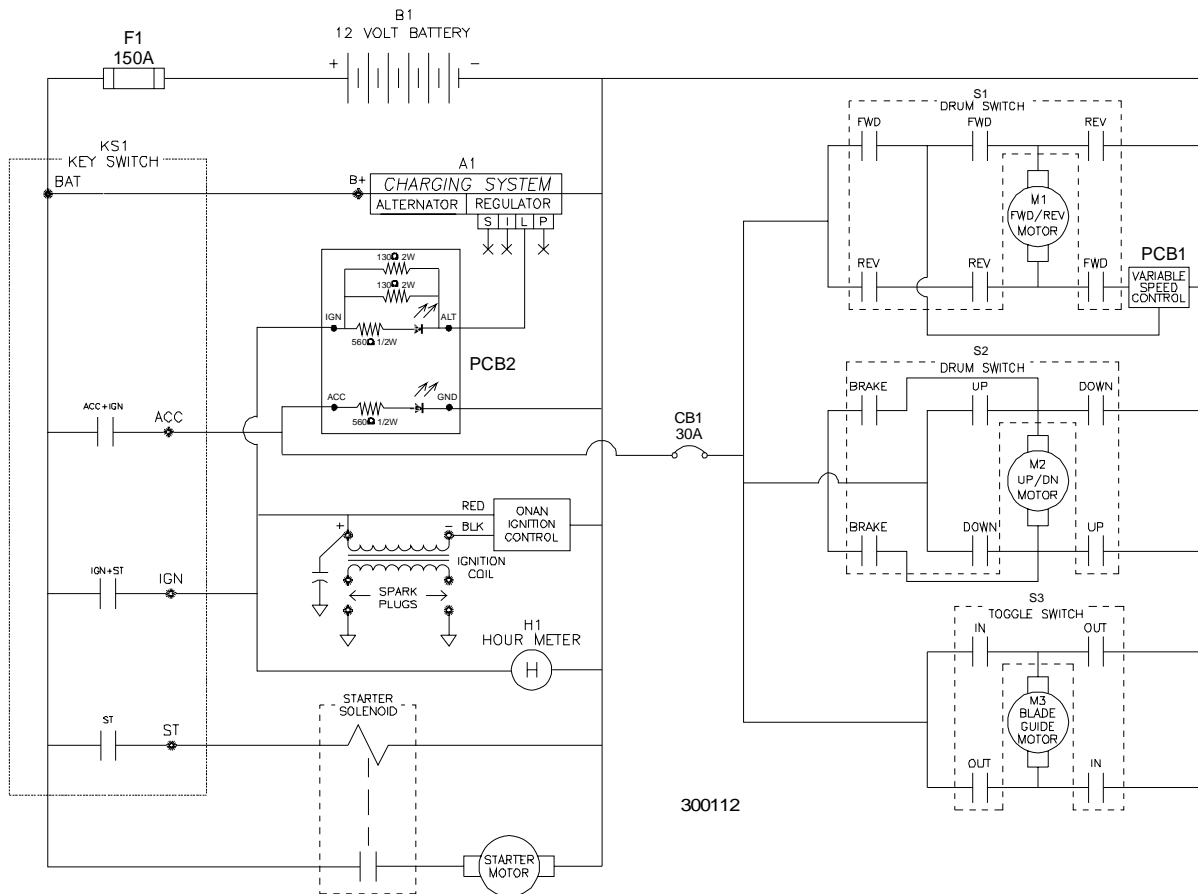

FIG. 5-1

5.2 Electrical Symbol Diagram, G24 LT30HD/LT40HD

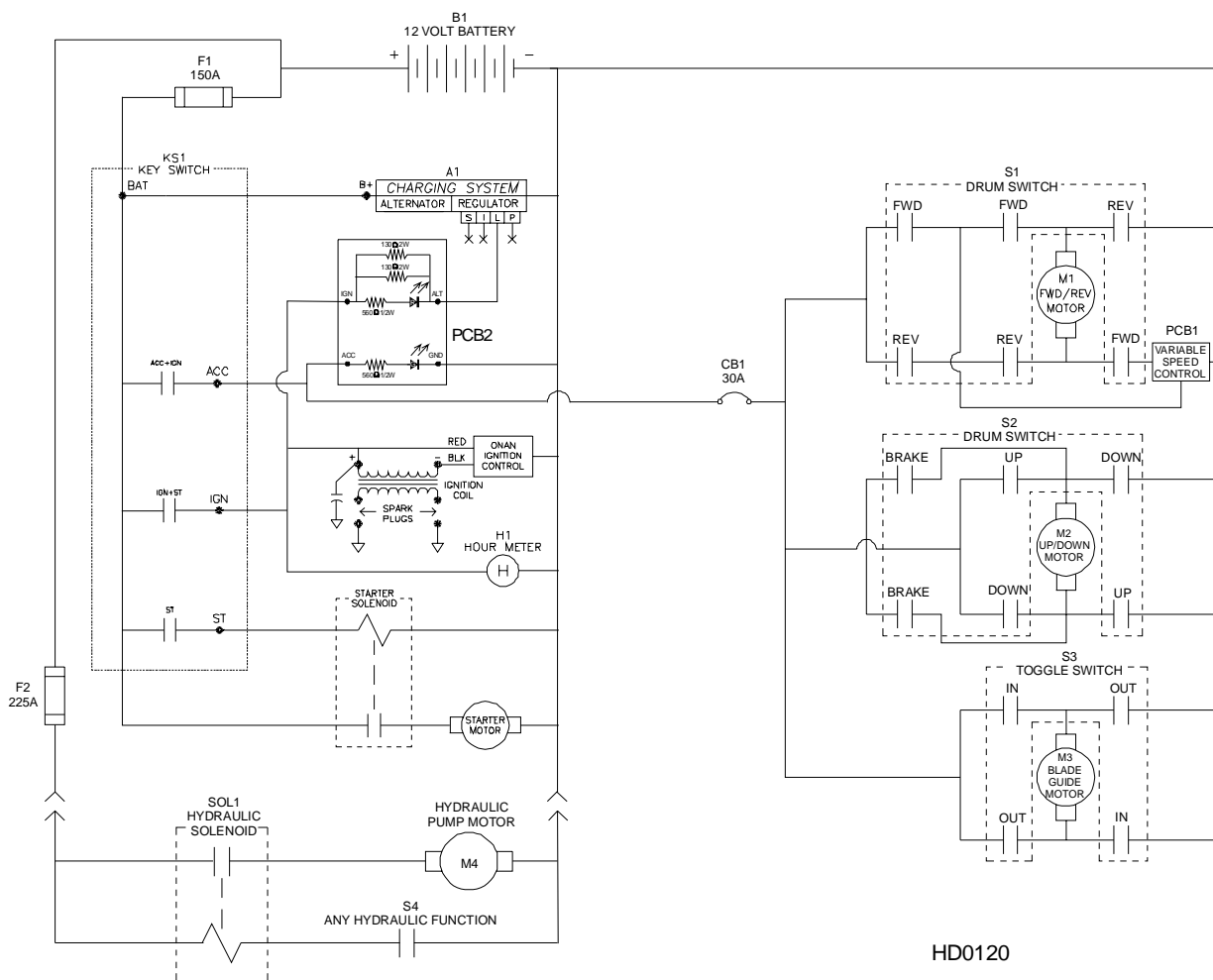

FIG. 5-2

5.3 Electrical Components, G24 LT30/LT40

Component	Manufacturer Part No.	Manufacturer	Wood-Mizer Part No.	Description
A1	CS-121	Delco-Remy	P03804	Alternator, 12 Volt, 61 Amp Maximum
B1	8T24	Deka	P09853	Battery, 12 Volt Deep Cycle (See Battery Specifications)
CB1	30128-30	Cole-Hersee	E20486	Circuit Breaker, 30 Amp, 12 Volt, For Power Feed Motor, Auto Reset
F1	RL-150	Gould	023361	Fuse Link, 150 Amp, 250 Volt For Main + 12 Volt Starter, Alternator
H1	T14BH517BC9	ENM Corp.	015401	Hour Meter, 12 Volt, Low Power T14 Series
KS1	121801	General	P04350	Key Switch, 4-position (Accessory, Off, Ignition, Start)
M1	PR4R0009Q	Owosso	014359	Motor, 12 Volt Power Feed
M2	PR-4P07Q	Owosso	A07974	Motor, 12 Volt Up/Down
M3	P09698-1	Klauber	A10365	Motor, 12 Volt Blade Guide Arm 53:1 Gear
PCB1	015410	Wood-Mizer	015410	Circuit Board, Control Box
PCB2	015416	Wood-Mizer	015416	Circuit Board, LED Circuit (Gas/Elec)
S1	2601-AF2-S11	Square D	E20439	Drum Switch, (U.S.), Power Feed Fwd/Reverse Motor
S2	2601-AF2-S12	Square D	E20440	Drum Switch, Up/Down Motor
S3	34-591Q	Pollak	024200	Toggle Switch, Blade Guide In/Out Motor

TABLE 5-1

5.4 Battery Specifications, G24 LT30/LT40

Group No.	Type No.	Plates Per Battery	Performance Level	Quarts Of Acid	Approximate Weight		Maximum Overall Dimensions		
			Minutes @ 23 Amp Draw		Wet	Dry	Length	Width	Height
24	8T24	66	125 Minutes	5	42 lb. (19.05 kg)	27.5 lbs. (12.47 kg)	10.25 in. (260.35 mm)	6.75 in. (171.45 mm)	9.875 in. (250.83 mm)

TABLE 5-2

5 Electrical Information

Electrical Components, G24 LT30HD/LT40HD

5.5 Electrical Components, G24 LT30HD/LT40HD

Component	Manufacturer Part No.	Manufacturer	Wood-Mizer Part No.	Description
A1	CS-121	Delco-Remy	P03804	Alternator, 12 Volt, 61 Amp Maximum
B1	724MFD	Deka	P12315	Battery, 12 Volt (See Battery Specifications)
CB1	30128-30	Cole-Hersee	E20486	Circuit Breaker, 30 Amp, 12 Volt, For Power Feed Motor, Auto Reset
F1	RL-150	Gould	023361	Fuse Link, 150 Amp, 250 Volt For Main + 12 Volt Starter, Alternator
F2	RL-225	Gould	P11550	Fuse Link, 225 Amp, 250 Volt For Hydraulic +12 Volt Circuit
H1	T14BH517BC9	ENM Corp.	015401	Hour Meter, 12 Volt, Low Power T14 Series
KS1	121801	General	P04350	Key Switch, 4-position (Accessory, Off, Ignition, Start)
M1	PR4R0009Q	Owosso	014359	Motor, 12 Volt Power Feed
M2	PR-4P07Q	Owosso	A07974	Motor, 12 Volt Up/Down
M3	P09698-1	Klauber	A10365	Motor, 12 Volt Blade Guide Arm 53:1 Gear
M4	8111	Monarch Hyd.	P09955	Motor, 12 Volt Hydraulic Pump
PCB1	015410	Wood-Mizer	015410	Circuit Board, Control Box Power Feed
PCB2	015416	Wood-Mizer	015416	Circuit Board, LED Circuit (Gas/Elec)
S1	2601-AF2-S11	Square D	E20439	Drum Switch, (U.S.), Power Feed Fwd/Reverse Motor
S2	2601-AF2-S12	Square D	E20440	Drum Switch, Up/Down Motor
S3	34-591Q	Pollak	024200	Toggle Switch, Blade Guide In/Out Motor
S4	024198	Wood-Mizer	024198	Switch, Hydraulic Pump Levers
SOL1	586-902	Stancor	015470	Solenoid, 200A 12V SPST Hydraulic Pump Motor

TABLE 5-3

5.6 Battery Specifications, G24 LT30HD/LT40HD

Group No.	Type No.	Performance Level		Quarts Of Acid	Approximate Weight	Maximum Overall Dimensions		
		Cranking Performance	Reserve Capacity			Wet	Length	Width
24F	724MFD	875CC	135	6	47.0 lb. (21.32 kg)	10.25 in. (260.35 mm)	6.75 in. (171.45 mm)	9.0 in. (229.0 mm)

TABLE 5-4

5.7 Wiring Diagram, G24 LT30/LT40

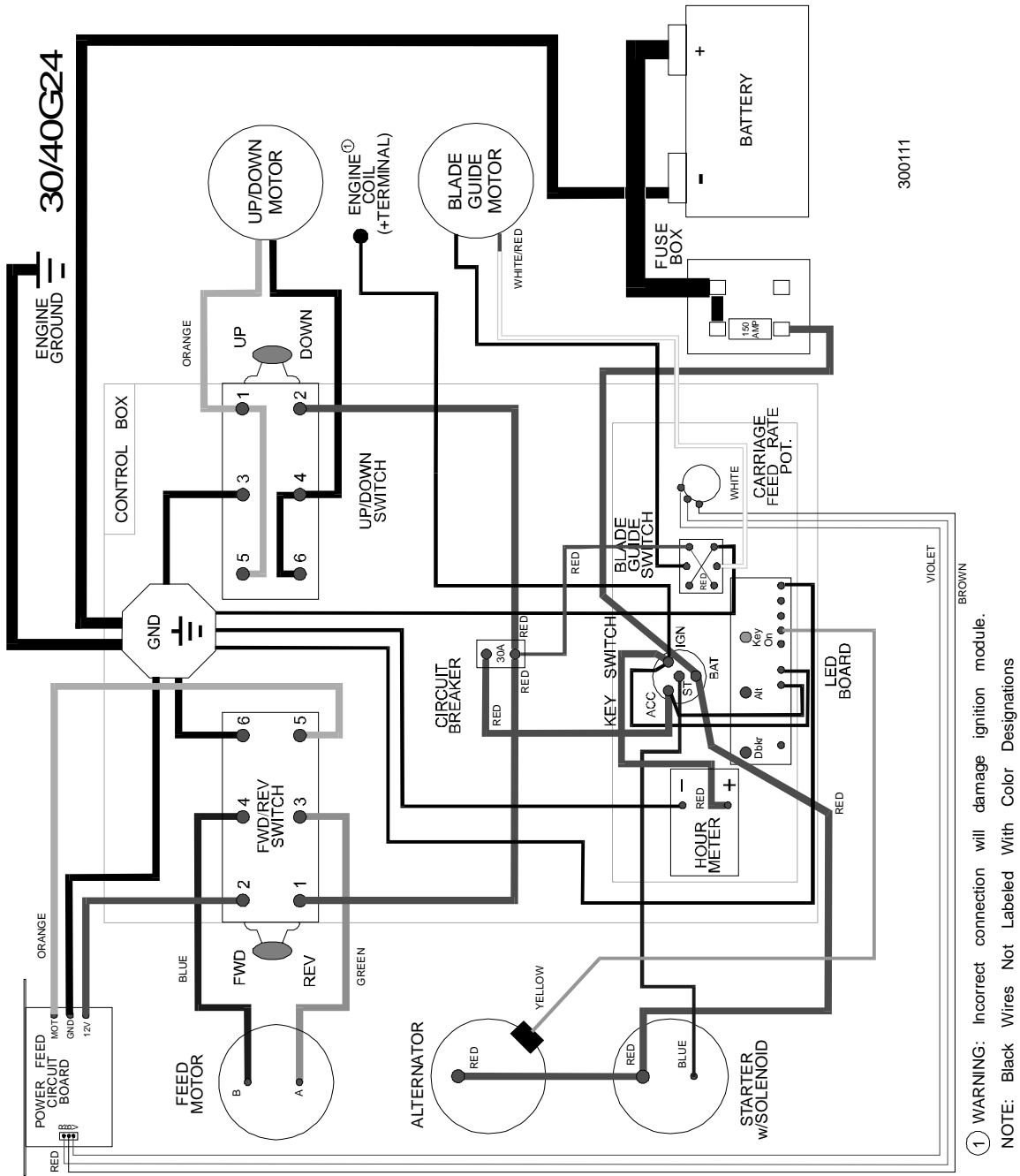

300111

① WARNING: Incorrect connection will damage ignition module.
 NOTE: Black Wires Not Labeled With Color Designations

FIG. 5-3

5.8 Wiring Diagram, G24 LT30HD/LT40HD

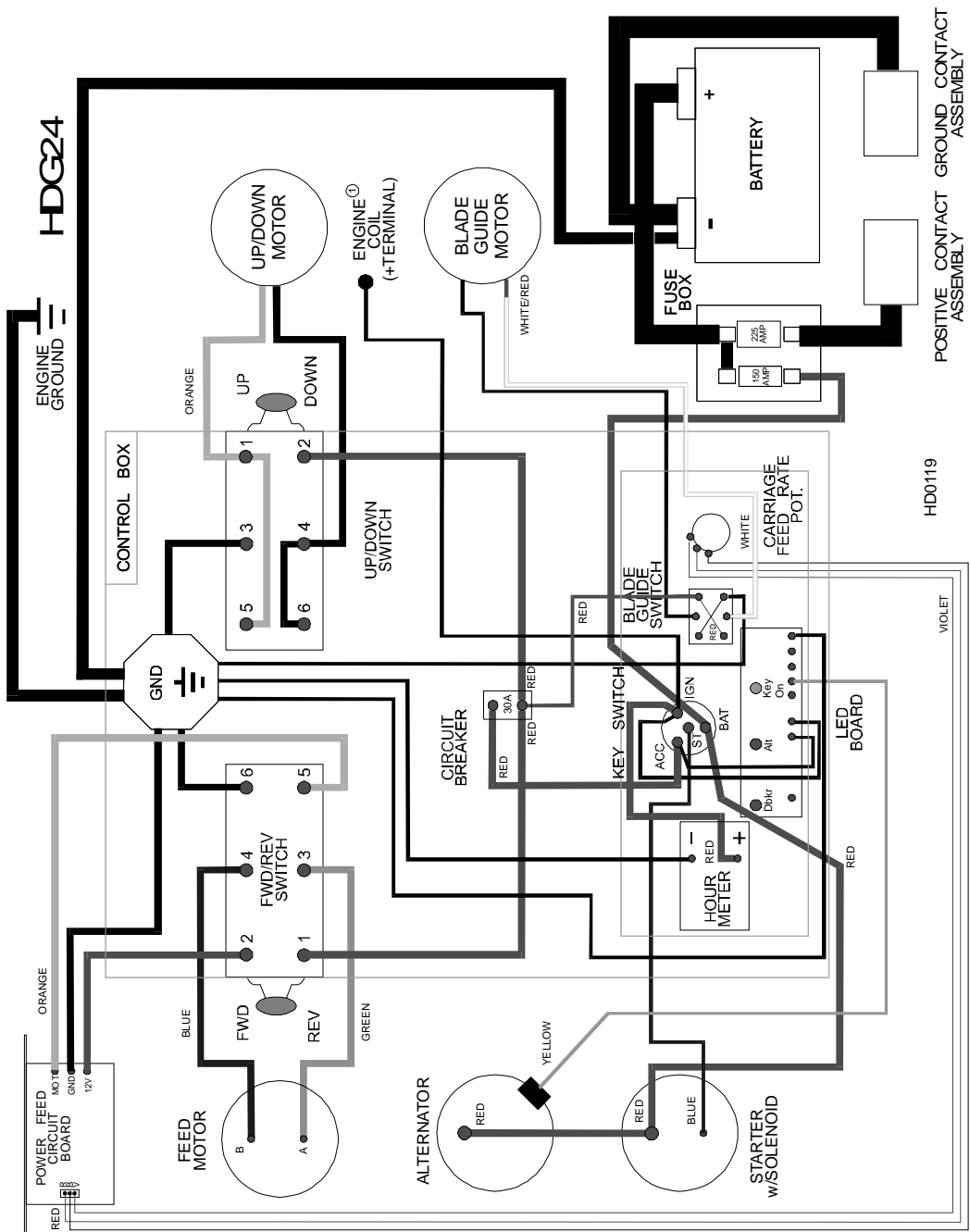

① WARNING: Incorrect connection will damage ignition module.
 NOTE: Black Wires Not Labeled With Color Designations

FIG. 5-4