

Wood-Mizer E15 Electric Option

LT25	rev. C5.00
LT30/40	rev. C6.00
LT30HD/40HD	rev. C7.00

Operator's Manual

Form #609

CAUTION!

The electric motor which operates the saw blade is capable of developing horsepower up to two or more times the horsepower listed on the motor nameplate. While the mill design allows for using this increased horsepower intermittently while sawing, it is possible in very aggressive cutting to overload the motor. Aggressive sawing for long periods may cause excessive heat buildup. An internal thermal protection device has been installed to ensure no damage to the motor can result from this overloading. This device shuts off the motor when its internal operating temperature becomes too hot. The motor will operate normally again after it cools (approximately 20 to 30 minutes).

Table of Contents

Section-Page

SECTION 1	SAFETY & GENERAL INFORMATION	1-1
1.1	Motor Operation	1-1
1.2	Electrical Diagrams	1-2
SECTION 2	OPERATION	2-1
2.1	Starting The Motor	2-1
2.2	Blade Rotation Change.....	2-1
SECTION 3	MAINTENANCE	3-1
3.1	Drive Belt	3-1
SECTION 4	REPLACEMENT PARTS	4-1
4.1	How To Use The Parts List	4-1
4.2	Sample Assembly	4-1
4.3	Motor Starter Box Assembly.....	4-2
4.4	Electric Motor Assembly.....	4-3
4.5	Motor Pulley Guards	4-4

SECTION 1 SAFETY & GENERAL INFORMATION



This symbol calls your attention to instructions concerning your personal safety. Be sure to observe and follow these instructions. This symbol accompanies a signal word. The word **DANGER** indicates an imminently hazardous situation which, if not avoided, will result in death or serious injury. **WARNING** suggests a potentially hazardous situation which, if not avoided, could result in death or serious injury. **CAUTION** refers to potentially hazardous situations which, if not avoided, may result in minor or moderate injury to persons or equipment. Read all safety instructions before operating this equipment and observe all safety warnings!

Read all safety instructions before operating this equipment and observe all safety warnings! Read the manufacturer's operation manual and observe any additional safety warnings applicable to the specific make and model you have purchased.

1.1 Motor Operation



DANGER! Always be sure the blade is disengaged and all persons are out of the path of the blade before starting the engine or motor. Failure to do so will result in serious injury.



WARNING! Hazardous voltage inside the disconnect box, starter box, and at the electric motor can cause shock, burns, or death. Disconnect power supply before servicing!

WARNING! Do not for any reason adjust the engine drive belts or belt support bracket with the engine running. Doing so may result in serious injury.

WARNING! Remove the blade before performing any engine service. Failure to do so may result in serious injury.

WARNING! Always wear proper and necessary safety equipment when performing service functions. Proper safety equipment includes eye protection, breathing protection, hand protection and foot protection.



IMPORTANT! Make sure the power cords are free to travel the length of the machine. An overhead boom system to keep the cords off of the floor is recommended.

1 Safety & General Information

Electrical Diagrams

1.2 Electrical Diagrams

See Table 1-1. The motor options available for the LT25E15 sawmills are listed below.

Engine/Motor Type	Manufacturer	Model No.	Power	Other Specifications
15HP Electric	Tamel SA, Poland	Sg 1328-2PG	11kW	22,3 A, 2950 RPM

TABLE 1-1

All the motors mentioned above are 2900-2920 RPM motors, 380V, 50Hz. They all have IP54 safety class, and -F isolation class.

The motor is powered through the starter box by the main switch, which along with 32A connector and plug, is located on the front of the starter box. Use only OW 5 x 6 mm² supplying wire or 5 x 10 mm² if the distance between the power source and working sawmill is large.

Attach the special arm, provided with the sawmill, to the mast, then hang the supplying wire that powers the starter box. The arm secures the operator and allows him to operate the sawmill safely.



DANGER! The starter box is always under hazardous voltage. Before opening the front door of the starter box, unplug the main connector to disconnect the power supply!

Make sure that at least once a year or after any repair a qualified electrician checks the installation on resistance and anti-shock security system.

Make sure the starter box is dust-free. Disconnect the power from time to time and clean inside of the box to remove any dust or wood chips. Do not operate or store with starter box door open.



DANGER! Hazardous voltage inside the starter box can cause shock, burns, or death. Disconnect the power supply before servicing.

See Figure 1-1. All the components located inside the E15 motor starter box are shown below.

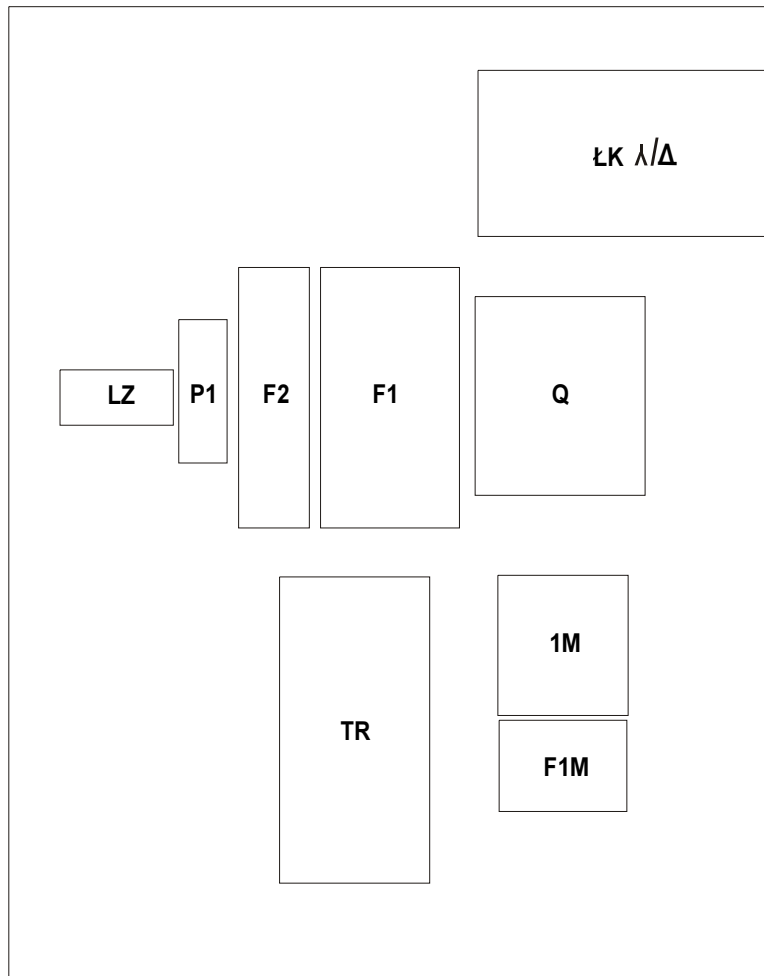

FIG. 1-1

All the components of the motor starter box shown in **Figure 1-1** are described below:

T1 - Control Transformer

F2 - Control Safety System

F1 - Tranformer Safety System

Q - Main Switch

L1 - Limit Switch Strip

P12 - Relay

Łk - Wye-Delta Switch

1M - LC1D18 Fuse

F1M - Motor Thermal Protection

1 Safety & General Information

Electrical Diagrams

See Figure 1-2. The E15 motor starter box wiring diagram is shown below.

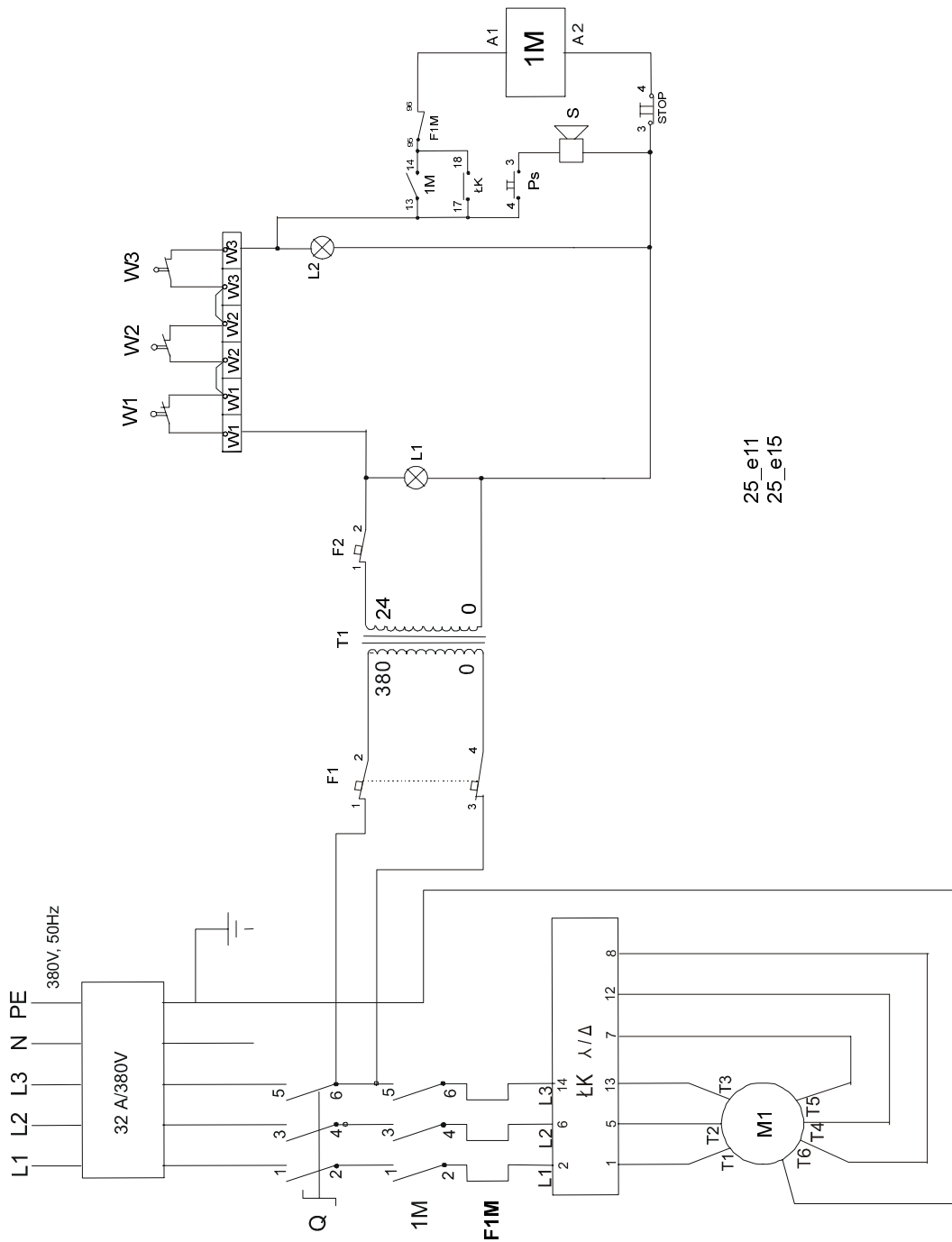

FIG. 1-2

The description of the diagram shown in **Figure 1-2**.

T1 - Control Transformer

F2 - Control Safety Switch

F1 - Transformer Safety Switch

Q - Main Switch

M1 - Blade Motor

F1M - Thermal Blade Motor Switch

W1 - Load Limit Switch

W2, W3 - Blade Covers Limit Switch

S - Sound Signal

Ps - Sound Signal Button

L1 - "Power On" Control Light

L2 - "Ready" Control Light

SECTION 2 OPERATION

2.1 Starting The Motor



DANGER! Do not start the motor when the clutch/brake lever is in the engaged (down) position. Always be sure the blade is disengaged and all persons are away from the blade before starting the motor.

DANGER! Push the emergency switch located on the LT25 mast, or on the left side of the LT30/40/HD control box, to stop the sawmill immediately.

LT25

The LT25 sawmills do not contain a separate control box. Turn on the main switch to start the motor. When the power is on the white control light located on the box door comes on. When all covers are closed green “ready” control light comes on. “Wye - Delta” manual switch set to “Wye” position. After 3-5 sec switch it to “Delta” position. The motor is ready to engage.

2.2 Blade Rotation Change

Make sure the blade rotation is correct as shown in the motor housing after starting an electric motor sawmill.

If the rotation is incorrect, disengage the blade by putting the Clutch/Brake lever to the upper position. Turn off the blade motor using the “Stop” switch located on the front of the starter box. Disconnect the starter box using the main switch, and disconnect the plug located on the left side of the starter box.

Then, with the screwdriver turn the phase converter switch (red switch at the bottom of the connector) to the right or to the left, and rotate it about 180° - this converts the phases and changes the blade rotation.

SECTION 3 MAINTENANCE



This symbol identifies the interval (hours of operation) which each maintenance procedure should be performed. "AR" signifies maintenance procedures which should be performed as required.

3.1 Drive Belt



Periodically check all belts for wear. Replace any damaged or worn belts as needed.



Adjust the drive belt support as needed. The drive belt support is designed to extend belt life. The spider bracket should be adjusted to NOT touch the drive belt when the clutch handle is engaged (down position), AND to hold the drive belt away from the engine pulley when the clutch handle is disengaged (up position).



DANGER! Do not for any reason adjust the drive belt support with the motor running. Always stop the motor before reaching or looking into the drive belt area.

SECTION 4 REPLACEMENT PARTS

4.1 How To Use The Parts List

- Use the table of contents or the index to locate the assembly that contains the part you need.
- Go to the appropriate section and locate the part in the illustration.
- Use the number pointing to the part to locate the correct part number and description in the table.
- Parts shown indented under another part are included with that part.
- Parts marked with a diamond (◆) are only available in the assembly listed above the part.

See the sample table below. Sample Part #A01111 includes part F02222-2 and subassembly A03333. Subassembly A03333 includes part S04444-4 and subassembly K05555. The diamond (◆) indicates that S04444-4 is not available except in subassembly A03333. Subassembly K05555 includes parts M06666 and F07777-77. The diamond (◆) indicates M06666 is not available except in subassembly K05555.

4.2 Sample Assembly				
REF	DESCRIPTION (◆ Indicates Parts Available In Assemblies Only)	PART #	QTY.	
	SAMPLE ASSEMBLY, COMPLETE (INCLUDES ALL INDENTED PARTS BELOW)	A01111	1	
1	Sample Part	F02222-22	1	
	Sample Subassembly (Includes All Indented Parts Below)	A03333	1	
2	Sample Part (◆ Indicates Part Is Only Available With A03333)	S04444-4	1	◆
	Sample Subassembly (Includes All Indented Parts Below)	K05555	1	
3	Sample Part (◆ Indicates Part Is Only Available With K05555)	M06666	2	◆
4	Sample Part	F07777-77	1	

To Order Parts:

- From Europe call our European Headquarters and Manufacturing Facility in Kolo, Poland at **+48-63-2610233** or **+48-3912-1319**. From the continental U.S., call **1-800-448-7881** to order parts. Have your customer number, vehicle identification number, and part numbers ready when you call.
- From other international locations, contact the Wood-Mizer distributor in your area for parts.

4 Replacement Parts

Motor Starter Box Assembly

4.3 Motor Starter Box Assembly

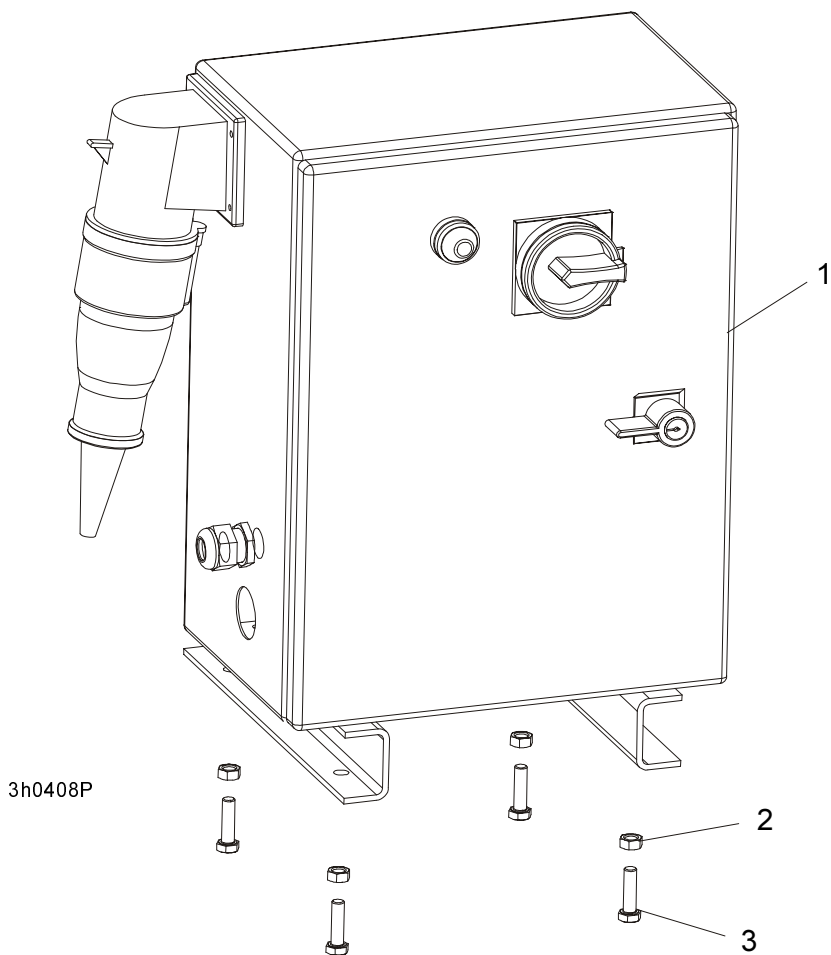

REF	DESCRIPTION (◆ Indicates Parts Available In Assemblies Only)	PART #	QTY.	
1	STARTER ASSEMBLY, 15HP 3-PHASE 50/60HZ ELECTRIC MOTOR	A11890-25	1	
	STARTER ASSEMBLY, 15HP 3-PHASE 50/60HZ ELECTRIC MOTOR	A11890	1	
2	NUT, M8-8-B HEX	F81032-1	4	
3	BOLT, M8 x 30 8.8-B HEX HEAD TAP	F81002-7	4	

4.4 Electric Motor Assembly

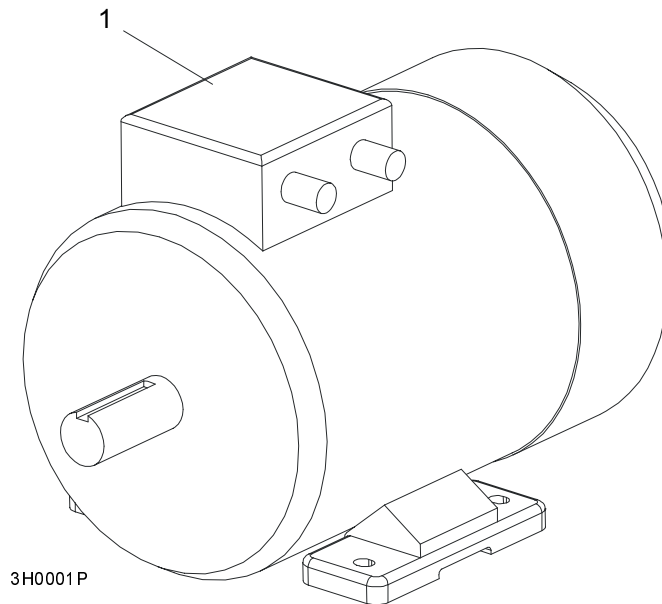

REF	DESCRIPTION (◆ Indicates Parts Available In Assemblies Only)	PART #	QTY.
	MOTOR ASSEMBLY, TAMEL S.A. 15HP ELECTRIC	EP15	1
1	MOTOR ASSEMBLY, 3-PHASE 15HP, 380V	P85186	1
	Pulley, 3-Groove Motor	085422	1
	Belt, 2BX70 Drive	P04857-2	1
	Plate, E15 Motor Mount	W85055-1	1
	Spacer, Electric Motor Adapter Plate	S12284	8
	Plate, Motor LT30/40	086803-1	1
	ALTERNATOR ASSEMBLY, W/BRACKET	K12801	1
	Alternator, DELCO 61A	P03804	1
	Belt, Alternator	P11628	1

4 Replacement Parts

Motor Pulley Guards

4.5 Motor Pulley Guards

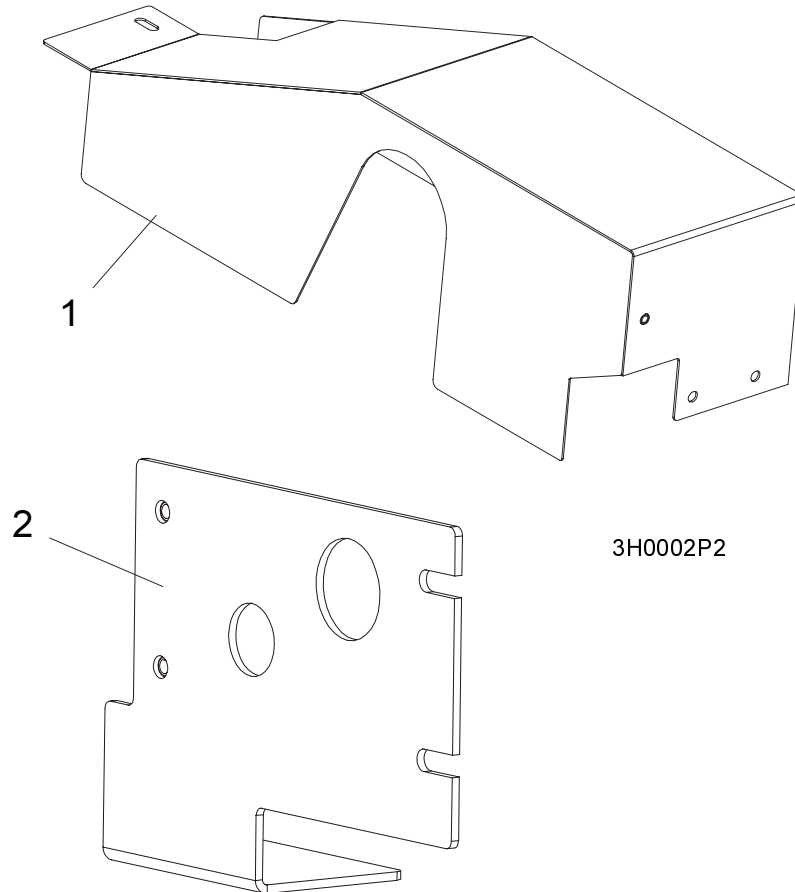

REF	DESCRIPTION (◆ Indicates Parts Available In Assemblies Only)	PART #	QTY.	
1	GUARD WELDMENT, E15 MOTOR PULLEY	085721-1	1	
2	BRACKET, E15 MOTOR PULLEY GUARD	087172	1	
	SUPPORT, DRIVE BELT (E15 ONLY)	086231-1	1	