

# Wood-Mizer<sup>®</sup> Sawmill

## Parts Manual

---

LT25  
LT25L

rev. C5.00  
rev. C5.00

---



**Safety is our #1 concern!** Read and understand all safety information and instructions before operating, setting up or maintaining this machine.

*Form #605*

# Table of Contents

# Section-Page

<b>SECTION 1</b>	<b>GENERAL INFORMATION</b>	<b>1-1</b>
1.1	How To Use The Parts List .....	1-1
1.2	Sample Assembly .....	1-1
<b>SECTION 2</b>	<b>BLADE GUIDE ROLLERS &amp; ARM</b>	<b>2-1</b>
2.1	Blade Guide Assembly, Idle Side.....	2-1
2.2	Blade Guide Assembly, Drive Side.....	2-3
2.3	Blade Guide Arm Assembly.....	2-5
<b>SECTION 3</b>	<b>BLADE WHEELS &amp; TENSIONER</b>	<b>3-1</b>
3.1	Blade Drive Assembly.....	3-1
3.2	Idle Blade Wheel Assembly .....	3-3
3.3	Hydraulic Blade Tensioner Assembly.....	3-4
<b>SECTION 4</b>	<b>SAW HEAD</b>	<b>4-1</b>
4.1	Middle Throat Screw .....	4-1
4.2	Clutch/Brake Lever Assembly .....	4-2
4.3	Water Lube Assembly .....	4-4
4.4	Saw Head Decals.....	4-6
4.5	Blade Housing Covers.....	4-8
4.6	Drive Belt Covers .....	4-10
4.7	Sawdust Chute.....	4-12
<b>SECTION 5</b>	<b>UP/DOWN SYSTEM</b>	<b>5-1</b>
5.1	Manual Up/Down Assembly .....	5-1
<b>SECTION 6</b>	<b>SAW HEAD MOUNT &amp; SCALES</b>	<b>6-1</b>
6.1	Saw Head V-Brace Mount .....	6-1
6.2	Blade Height Scale .....	6-2
<b>SECTION 7</b>	<b>TRACK ROLLERS</b>	<b>7-1</b>
7.1	Upper Track Rollers And Wipers .....	7-1
7.2	Lower Track Rollers .....	7-2
<b>SECTION 8</b>	<b>BED FRAME ASSEMBLY</b>	<b>8-1</b>
8.1	Bed Rail Assembly, Front And Rear .....	8-1
8.2	Bed Rail Assembly, Front Middle .....	8-3
8.3	Bed Rail Assembly, Rear Middle .....	8-4
8.4	Leg, Stationary .....	8-6
8.5	Pivot Bed Rail Assembly.....	8-8

**Table of Contents**

**Section-Page**

8.6	Log Side Support Assembly .....	8-10	
8.7	Tie Down Chain Assembly .....	8-12	
8.8	Bed Frame Decals .....	8-13	
<b>SECTION 9 LOG CLAMP</b>			<b>9-1</b>
9.1	Log Clamp .....	9-1	
9.2	Manual Log Turner.....	9-2	
9.3	Manual Toe Board.....	9-4	
9.4	Log Loading Ramps .....	9-6	
<b>SECTION 10 MANUAL FEED</b>			<b>10-1</b>
10.1	Manual Feed Rope Assembly .....	10-1	



## SECTION 1 GENERAL INFORMATION

### 1.1 How To Use The Parts List

- Use the index above to locate the assembly that contains the part you need.
- Go to the appropriate section and locate the part in the illustration.
- Use the number pointing to the part to locate the correct part number and description in the table.
- Parts shown indented under another part are included with that part.
- Parts marked with a diamond (◆) are only available in the assembly listed above the part.

See the sample table below. Sample Part #A01111 includes part F02222-2 and subassembly A03333. Subassembly A03333 includes part S04444-4 and subassembly K05555. The diamond (◆) indicates that S04444-4 is not available except in subassembly A03333. Subassembly K05555 includes parts M06666 and F07777-77. The diamond (◆) indicates M06666 is not available except in subassembly K05555.

<b>1.2 Sample Assembly</b>				
REF	DESCRIPTION (◆ Indicates Parts Available In Assemblies Only)	PART #	QTY.	
	Sample Assembly, Complete (Includes All Indented Parts Below)	A01111	1	
1	Sample Part	F02222-22	1	
	Sample Subassembly (Includes All Indented Parts Below)	A03333	1	
2	Sample Part (◆ Indicates Part Is Only Available With A03333)	S04444-4	1	◆
	Sample Subassembly (Includes All Indented Parts Below)	K05555	1	
3	Sample Part (◆ Indicates Part Is Only Available With K05555)	M06666	2	◆
4	Sample Part	F07777-77	1	

#### **To Order Parts:**

- From Europe call our European Headquarters and Manufacturing Facility in Kolo, Poland at **+48-63-2610233**. From the continental U.S., call our toll-free Parts hotline at **1-800-448-7881**. Have your customer number, vehicle identification number, and part numbers ready when you call.
- From other international locations, contact the Wood-Mizer distributor in your area for parts.



## SECTION 2 BLADE GUIDE ROLLERS & ARM

### 2.1 Blade Guide Assembly, Idle Side

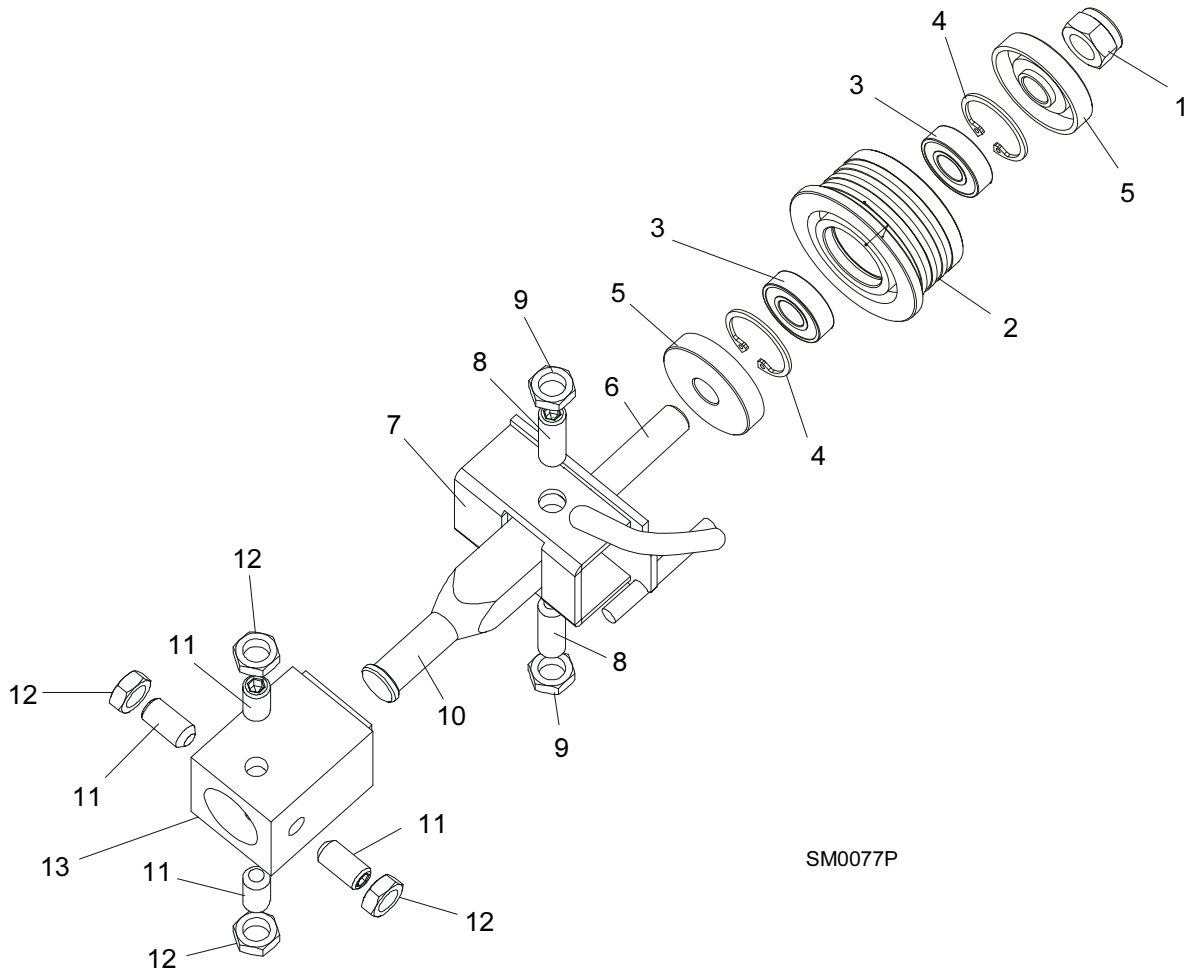

REF	DESCRIPTION (◆ Indicates Parts Available In Assemblies Only)	PART #	QTY.	
	<b>BLADE GUIDE ASSEMBLY, COMPLETE IDLE SIDE</b>	A08197	1	
	Roller, Blade Guide With Bearings	087887	1	
	Roller, Blade Guide With Bearings Extended (for optional use with 1 1/2" blades)	087888 <sup>1</sup>	1	
1	Nut, M12-8 Fe/Zn5 Jam Nylon Lock	F81034-2	1	
2	Roller, Flanged Blade Guide	087889	1	◆
	Roller, Blade Guide Extended (for optional use with 1 1/2" blades)	087890 <sup>1</sup>	1	◆
3	Bearing, R8-2RS Blade Guide	087893	2	
4	Ring, 1 1/8" Interior Retaining	F81090-9	2	
5	Spacer, Blade Guide	087891	2	
6	Bolt, Blade Guide Mounting	087763	1	
7	Bracket, Blade Guide Idle Side With Water Tube	W08495	1	
	Screw Kit, Blade Guide Adjustment w/Nuts (For two blade guide assemblies)	K09942	1	
8	Screw, 3/8-24 X 1 1/4" Stainless Steel Socket Head Flat Point	F05007-96	4	

**2****Blade Guide Rollers & Arm***Blade Guide Assembly, Idle Side*

---

9	Nut, 3/8-24 Jam	F05010-22	4	
10	Shaft, Blade Guide Adjustment	S08196	1	
11	<b>SCREW, 3/8-24 X 3/4" STAINLESS STEEL SOCKET HEAD FLAT POINT</b>	F05007-95	4	
12	<b>NUT, 3/8-24 JAM</b>	F05010-22	4	
13	<b>TUBE, BLADE GUIDE MOUNT</b> ( <a href="#">See Section 2.3 Blade Guide Arm Assembly</a> )	W08159	1	

<sup>1</sup> Recommended for Super sawmills only.



**2.2 Blade Guide Assembly, Drive Side**

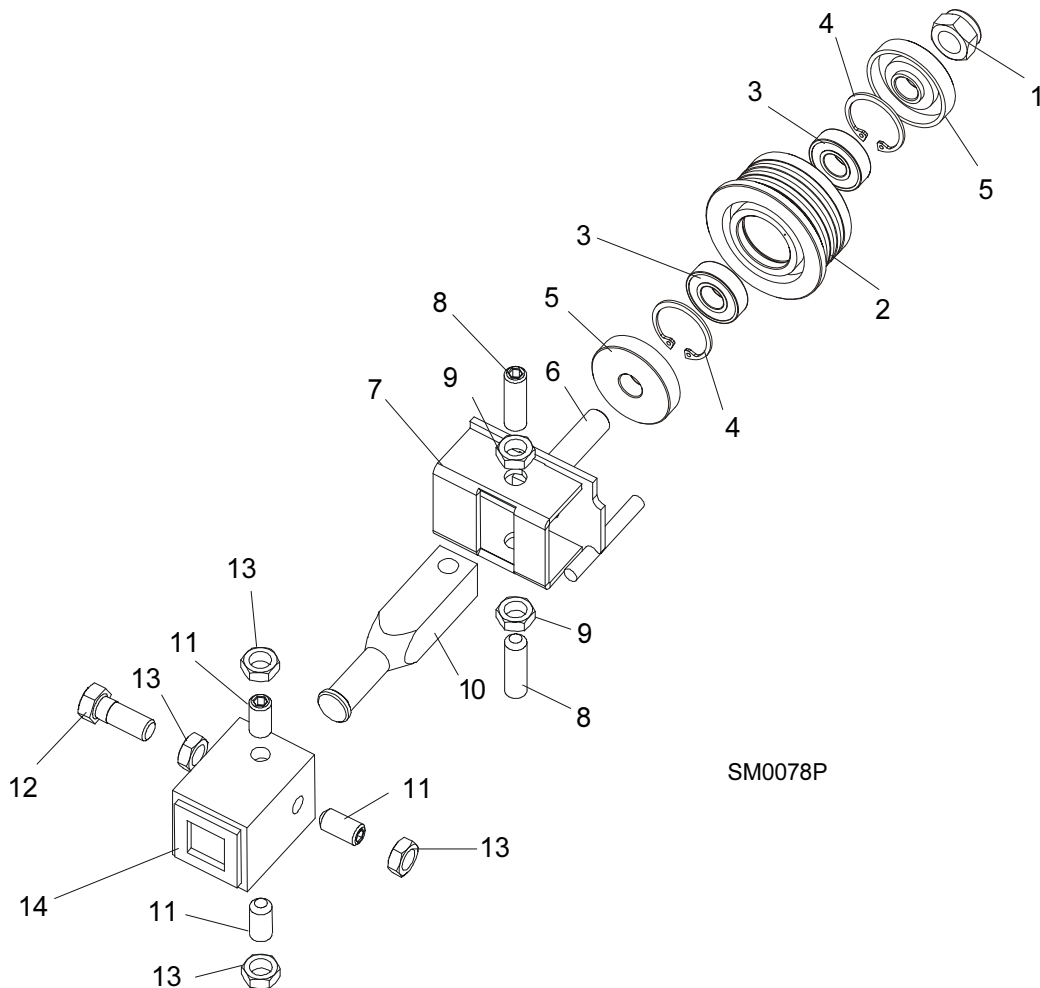

REF	DESCRIPTION (◆ Indicates Parts Available In Assemblies Only)	PART #	QTY.	
	<b>BLADE GUIDE ASSEMBLY, COMPLETE DRIVE SIDE</b>	A08191	1	
	Roller, Blade Guide With Bearings	087887	1	
	Roller, Blade Guide With Bearings Extended (for optional use with 1 1/2" blades)	087888 <sup>1</sup>	1	
1	Nut, M12-8 Fe/Zn5 Jam Nylon Lock	F81034-2	1	
2	Roller, Flanged Blade Guide	087889	1	◆
	Roller, Blade Guide Extended (for optional use with 1 1/2" blades)	087890 <sup>1</sup>	1	◆
3	Bearing, R8-2RS Blade Guide	087893	2	
4	Ring, 1 1/8" Interior Retaining	F81090-9	2	
5	Spacer, Blade Guide	087891	2	
6	Bolt, Blade Guide Mounting	087763	1	
7	Bracket, Blade Guide Drive Side	W08482	1	
	Screw Kit, Blade Guide Adjustment w/Nuts (For two blade guide assemblies)	K09942	1	

# 2

## Blade Guide Rollers & Arm

### *Blade Guide Assembly, Drive Side*

8	Screw, 3/8-24 X 1 1/4" Stainless Steel Socket Head Flat Point	F05007-96	4	
9	Nut, 3/8-24 Jam	F05010-22	4	
10	Shaft, Blade Guide Adjustment	S08196	1	
11	<b>SCREW, 3/8-24 X 3/4" STAINLESS STEEL SOCKET HEAD FLAT POINT SET</b>	F05007-95	3	
12	<b>BOLT, 3/8-24 X 1" STAINLESS STEEL HEX HEAD</b>	F05007-99	1	
13	<b>NUT, 3/8-24 JAM</b>	F05010-22	4	
14	<b>TUBE, BLADE GUIDE MOUNT (Part of Saw Frame Weldment)</b>	W08159	1	

<sup>1</sup> Recommended for Super sawmills only.

## 2.3 Blade Guide Arm Assembly

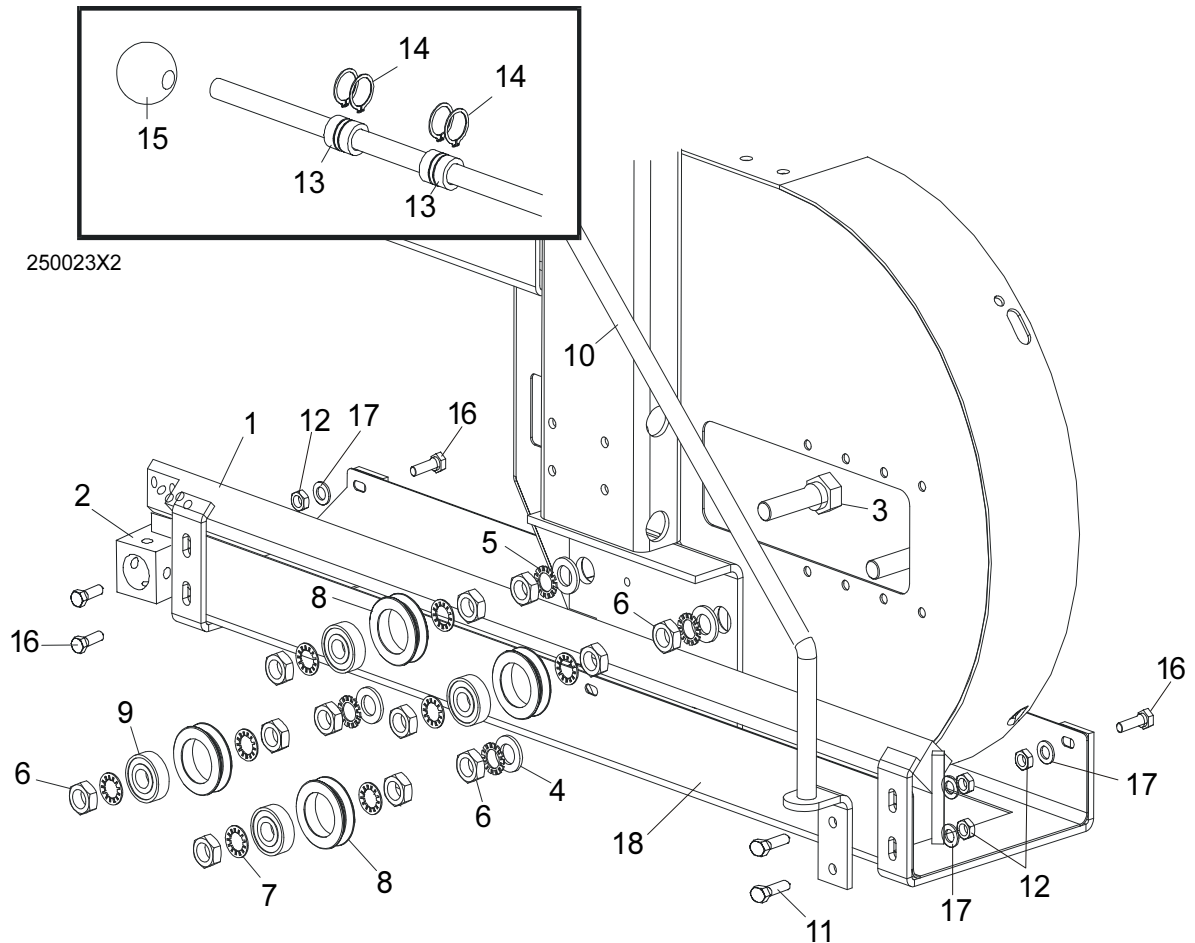

REF	DESCRIPTION (◆ Indicates Parts Available In Assemblies Only)	PART #	QTY.
1	<b>BLADE GUIDE ARM WELDMENT</b>	087018-1	1
2	Tube, Blade Guide Mount	W08159	1
3	<b>BOLT, BLADE GUIDE ARM ROLLER CAM</b>	W09067	4
4	<b>WASHER, 17 FLAT</b>	F81058-1	4
5	<b>WASHER, 5/8" EXTERNAL STAR</b>	F05011-26	4
6	<b>NUT, 5/8-18 HEX JAM</b>	F05010-11	12
7	<b>WASHER, 5/8" INTERNAL STAR</b>	F05011-25	8
	<b>ROLLER ASSEMBLY, BLADE GUIDE ARM WITH BEARING</b>	A09059	4
8	Roller, Blade Guide Arm V-Groove	S07989-W	1
9	Bearing, 6203-2NSL 5/8" I.D.	P06030-1	1
10	<b>HANDLE, LT25 BLADE GUIDE ARM ADJUSTMENT</b>	086933	1
11	<b>BOLT, M8X25-8.8-B-ZINC HEX HEAD</b>	F81002-5	2
12	<b>NUT, M8-8-B-ZINC HEX NYLON LOCK</b>	F81032-2	6
13	<b>BEARING, BLADE GUIDE ARM SLIDE</b>	S12436	2
14	<b>RING, 1" EXTERNAL RETAINING</b>	F04254-15	4
15	<b>KNOB, PLASTIC ROUND</b>	P04211	1
16	<b>BOLT, M8X20-8.8 ZINC HEX HEAD</b>	F81002-11	4

**2****Blade Guide Rollers & Arm***Blade Guide Arm Assembly*

---

17	WASHER 8,4-ZINC ROUND	F81054-1	6	
18	COVER WELDMENT, DRIVE BLADE	087042-1	1	

## SECTION 3 BLADE WHEELS & TENSIONER

### 3.1 Blade Drive Assembly

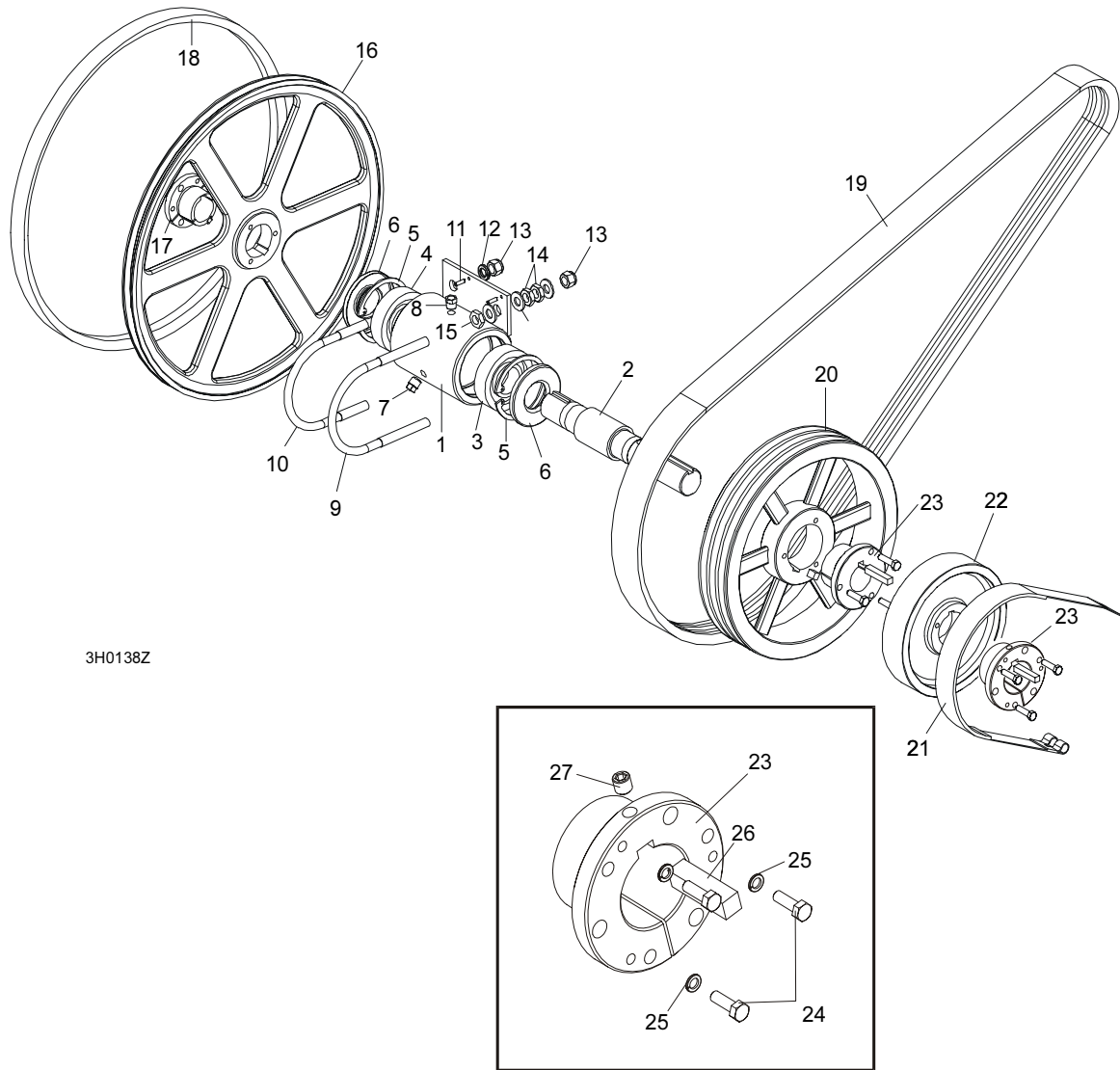

REF	DESCRIPTION (◆ Indicates Parts Available In Assemblies Only)	PART #	QTY.	
	<b>BEARING ASSEMBLY, BLADE WHEEL DRIVE</b>	086291	1	
1	Housing, Blade Wheel Drive Bearing	086293	1	◆
2	Shaft, Blade Wheel Drive	086292	1	
3	Bearing, Blade Wheel Drive NJ308	085939	1	
4	Bearing, Blade Wheel Drive #6308 C3 Open	085940	1	
5	Ring, 90mm Interior Retaining #117	F04254-17	2	
6	Seal, Drive Bearing #CR15890	P10206	2	
7	Plug, 1/4" NPT Square Head	P11757	1	
8	Plug, 1/4" NPT Vented	P12868	1	

# 3

## Blade Wheels & Tensioner

### Blade Drive Assembly

9	Bolt, 1/2-13 Long U	S10207-1P	1	
10	Bolt, 1/2-13 Short U	S10207-2P	1	
11	Pin, 3/16" X 5/8" Roll	F05012-22	2	
12	Washer, 12.2 Split Lock	F81056-2	2	
13	Nut, M12-8 Hex Nylon Lock	F81034-2	4	
14	Nut, M12-8-B Hex Jam	F81034-1	6	
15	Washer, 13 Flat	F81056-1	6	
	Decal, Bearing End-Play	S12750	1	
	Instruction Sheet, Bearing Retrofit	K10200-275	1	
	<b>PLATE, DRIVE BEARING MOUNT</b>	016116	1	
	<b>BAR, BEARING PLATE BRACE</b>	016113	1	
	<b>BLOCK, BEARING PLATE BRACE</b>	016112	1	
	<b>SCREW, 1/2-20 X 2 1/2" SQUARE HEAD FULL THREAD SET</b>	F05008-110	1	
	<b>WHEEL KIT, DRIVE SIDE BLADE</b>	014562	1	
16	Wheel, Drive Side Blade	P12891	1	
17	Bushing, Modified 1 9/16" P1	087214	1	
	Instruction Sheet, Drive Side Blade Wheel Replacement	K12987-488	1	
18	<b>BELT, BLADE WHEEL B57</b>	P04185	1	
19	<b>BELT, BX72 DRIVE (G11)</b>	P09555	1	
	<b>BELT, 2BX72 Drive (G15)</b>	P09555-2	1	
20	<b>PULLEY, 2B5V124 SPECIAL ()</b>	087205-1	1	
	<b>PULLEY, 1B5V124 DRIVE (G11)</b>	087205-1	1	
21	<b>STRAP, METAL-BACKED BRAKE</b>	014391	1	
22	<b>WHEEL, BRAKE</b>	087204-1	1	
	<b>SHAFT (086291) BUSHINGS SERVICE KIT</b>	089793	3	
23	Bushing, Modified 1 9/16" P1	087214	3	
24	Bolt <b>UNC 1/4"X1 1/2" -8.8-Zinc</b>	F05005-31	9	
25	Split washer lock <b>1/4" UNC Zinc</b>	F81052-21	9	
26	Key <b>9.5H7X9.5X3.8</b>	087384	3	
27	Screw, <b>M8X8-33H-Zinc</b> Hex Socket Head Cap	F81014-1	3	

### 3.2 Idle Blade Wheel Assembly

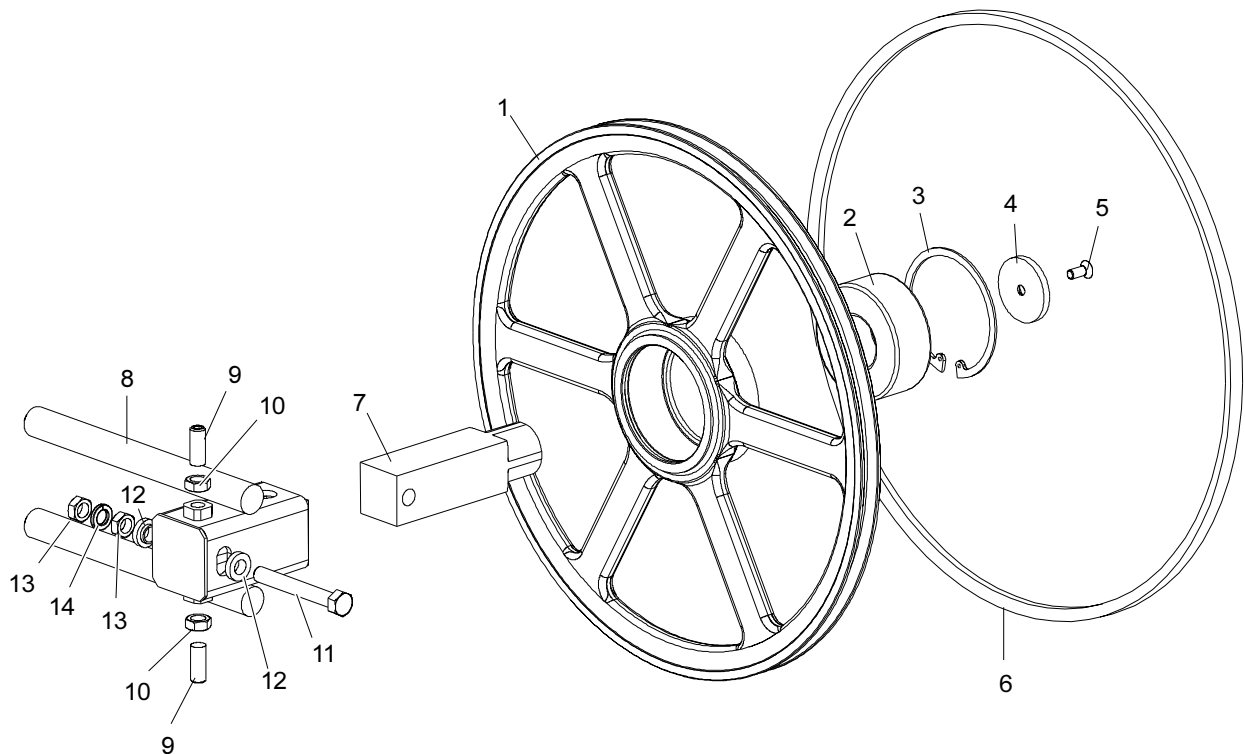

SM0241

REF	DESCRIPTION (◆ Indicates Parts Available In Assemblies Only)	PART #	QTY.	
	<b>WHEEL ASSEMBLY, IDLE SIDE BLADE</b>	016120	1	
1	Wheel, Idle Side Blade	016013	1	◆
2	Bearing, Idle Side Blade Wheel #5309-2RS, C3, SRI-2 Grease	086428	1	
3	Ring, 100mm Internal Retaining Beveled	F04254-28	1	
4	RETAINER, 2 3/16 X 1/4"	016397	1	
5	BOLT, 5/16-18 X 3/4" FLAT HEAD SOCKET	F05006-95	1	
6	BELT, BLADE WHEEL B57	P04185	1	
7	SHAFT, IDLE BLADE WHEEL	016398	1	
8	HOUSING, IDLE BLADE WHEEL SHAFT	016103	1	
9	SCREW, 1/2-20 X 1 1/4" FLAT POINT SET	F05008-108	2	
10	NUT, 1/2-20 HEX JAM	F05010-16	2	
11	BOLT, 1/2-20 X 3 3/4" HEX HEAD FULL THREAD GRADE 2	F05008-111	1	
12	SPACER, 1/2" I.D. FLANGED	086769-1	2	
13	NUT, 1/2-20 HEX JAM	F05010-16	2	
14	WASHER, 12.2 SPLIT LOCK	F81056-2	1	

### 3.3 Hydraulic Blade Tensioner Assembly

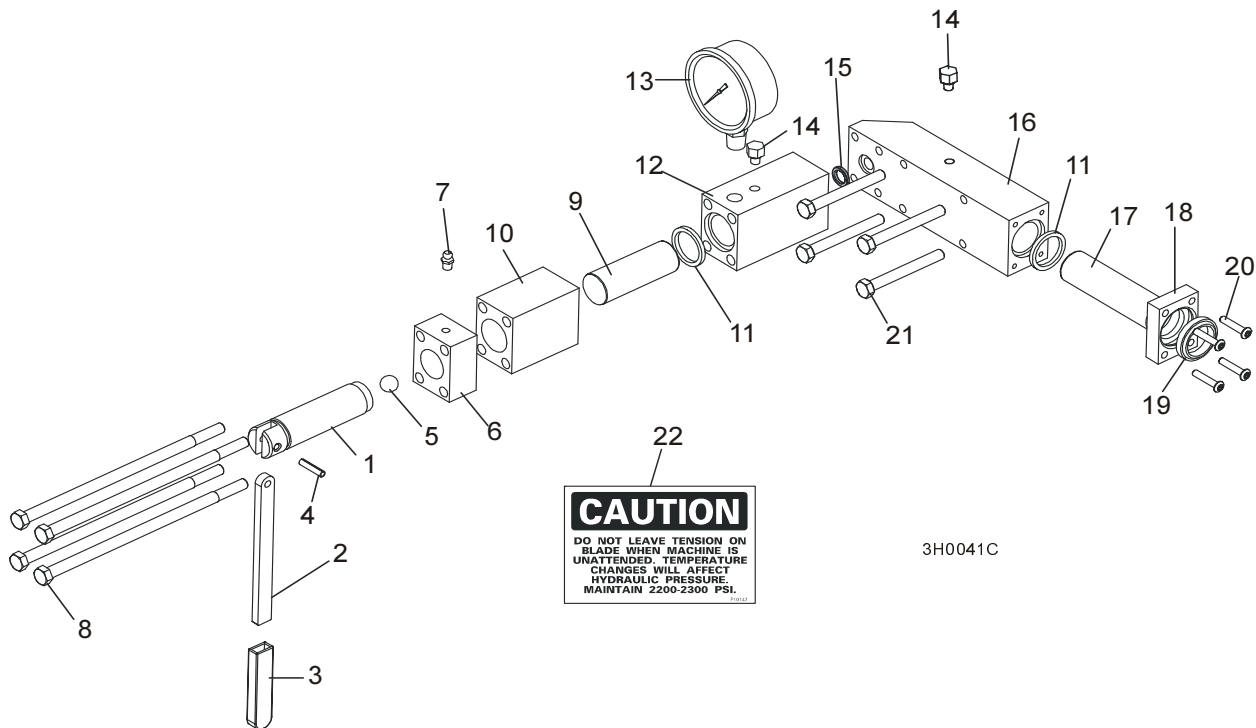

REF	DESCRIPTION (◆ Indicates Parts Available In Assemblies Only)	PART #	QTY.
	<b>HYDRAULIC BLADE TENSIONER ASSEMBLY</b>	A10054	1
	Handle Assembly, Hydraulic Blade Tensioner Screw	A12294	1
1	Screw, Hydraulic Blade Tensioner	S10056	1
2	Handle, Hydraulic Tensioner Screw	S08174	1
3	Sleeve, Plastic Handle	P08072	1
4	Pin, 3/16" x 7/8" Roll	F05012-19	1
5	Ball, 1/2" Steel	P02720	1
6	Block, Threaded Tensioner End	S10062	1
7	Fitting, 1/4-28 Grease	P05060	1
	Instruction Sheet, Tensioner Screw	A12294-518	1
8	Bolt, 5/16-18 X 7 1/2" Hex Head Grade 5	F05006-43	4
9	Piston, Hydraulic Tensioner Front 2 3/4" Long	S10060	1
10	Block, Piston Guide	S10061	1
11	Seal, 1" Diameter	P10051	2
12	Block, Hydraulic Tensioner Gauge Mounting	S10140	1
13	Gauge, 3000 PSI	090552	1
14	Plug, Hydraulic Tensioner Fill	P10065	2
15	Ring, 5/8" X 3/32" Square "O"	P10377	1
16	Block, Rear Tensioner Piston	S10142	1
17	Piston, Hydraulic Tensioner Rear 3 5/8" Long	S10059	1
18	Block, Rear Piston End	S10089	1
19	Wiper, 1" Diameter	P10053	1
20	Bolt, #10-24 X 1" Socket Button Head	F05004-43	4



21	Bolt, 5/16-18 X 2 3/4" Hex Head Grade 5	F05006-28	4	
22	Decal, Hydraulic Tension Caution	P10147	1	
	Instruction Sheet, Hydraulic Tensioner Installation	A10136-272	1	



## SECTION 4 SAW HEAD

### 4.1 Middle Throat Screw

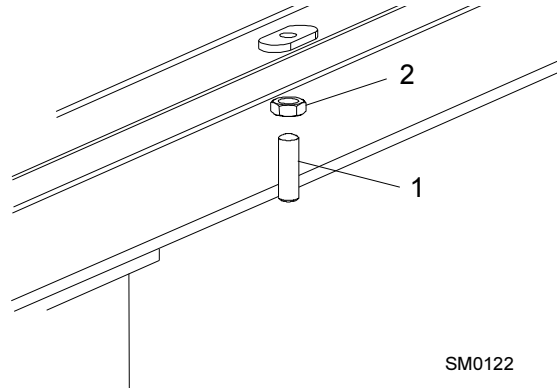

REF	DESCRIPTION (◆ Indicates Parts Available In Assemblies Only)	PART #	QTY.	
1	SCREW, 3/8-16 X 1 1/4" OVAL POINT SOCKET SET	F05007-18	1	
2	NUT, 3/8-16 HEX JAM	F05010-29	1	

# 4 Saw Head

## Clutch/Brake Lever Assembly

### 4.2 Clutch/Brake Lever Assembly

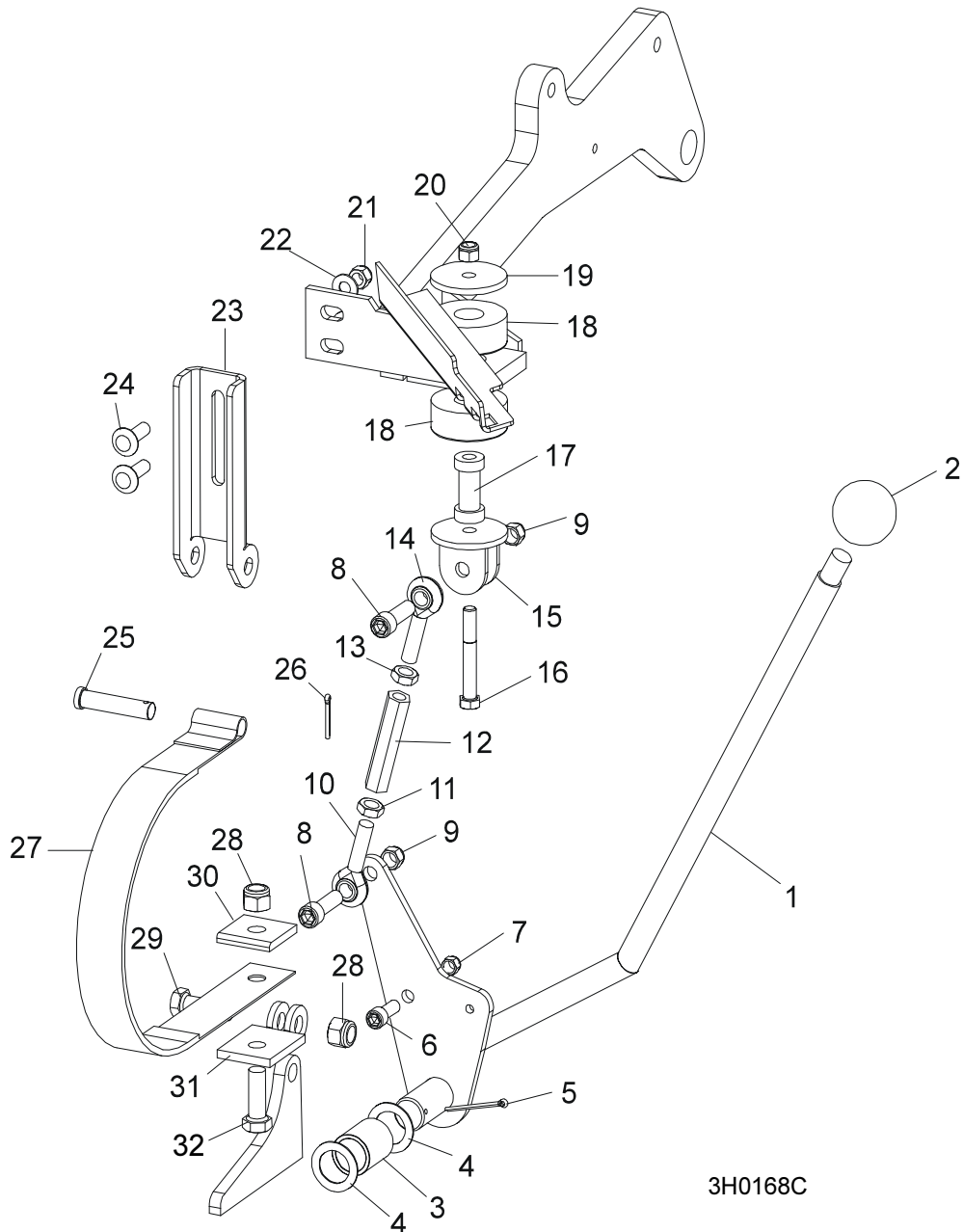

3H0168C

REF	DESCRIPTION (◆ Indicates Parts Available In Assemblies Only)	PART #	QTY.	
	<b>LEVER ASSEMBLY, CLUTCH/BRAKE</b>	A12334	1	
1	Lever, Clutch/brake	085701	1	◆
2	Knob, Plastic Round	086337	1	
3	Bushing, Clutch/Brake Pivot	P05041	1	
4	Washer, Clutch/Brake Pivot	S11570	2	
5	Pin, S-Zn 4 x 45 Cotter	F81043-21	1	
6	<b>BOLT, 3/8-16 X 1" SOCKET HEAD</b>	F05007-52	1	
7	<b>NUT, 3/8-16 HEX NYLON LOCK</b>	F05010-10	1	

8	<b>NUT, 7/16-20 HEX NYLON LOCK</b>	F05010-83	2	
9	<b>BOLT, 7/16-20 X 1 1/2" SOCKET HEAD</b>	F05007-55	2	
	<b>TURNBUCKLE ASSEMBLY, CLUTCH/BRAKE LEVER</b>	A12304	1	
10	Rod End, 7/16-20 Right Hand Thread	P11579	1	
11	Nut, 7/16-20 Hex Jam	F05010-38	1	
12	Turnbuckle, 3" Clutch/Brake Lever	S11577-W	1	◆
13	Nut, 7/16-20 Hex Jam Left Hand Thread	F05010-87	1	
14	Rod End, 7/16-20 Left Hand Thread	P11578	1	
15	<b>BRACKET, CLUTCH MOUNT</b>	W12411-1	1	
16	Bolt, 3/8-16 x 2 3/4" Hex Head	F05007-29	1	
17	<b>SPACER, MOTOR MOUNT VIBRATION BUSHING</b>	S12410	1	
18	<b>BUSHING, MOTOR MOUNT VIBRATION</b>	P05032	2	
19	<b>WASHER, 3/8" I.D. X 2 1/4" O.D. X 3/16" THICK</b>	S12412-0	1	
20	<b>NUT, 3/8-16 NYLON LOCK</b>	F05010-10	1	
	<b>STRAP RETROFIT, BRAKE</b>	014441	1	
21	Nut, 3/8-16 Nylon Lock	F05010-10	2	
22	Washer, 10.5 Flat	F81055-1	2	
23	Bracket, Upper Brake Strap Mount	014395	1	
24	Bolt, 3/8-16 x 1 1/4" Carriage Head Grade 5	F05007-127	2	
25	Pin, 1/2" x 2 1/4" Clevis	F05012-81	1	
26	Pin, 1/8" x 1" Cotter	F05012-1	1	
27	Strap, Upper Pivot Metal Brake	014391	1	
28	Nut, 1/2-13 Nylon Lock	F81034-2	2	
29	Bolt, 1/2-13 x 1 1/2" Hex Head Grade 5	F81004-4	2	
30	Plate, Brake Strap Clamp	S04195	1	
31	Bracket, Lower Brake Strap Mount	014392	1	
32	Bolt, M12x30-8.8-Zinc Hex Head	F81004-22	1	

# 4 Saw Head

## Water Lube Assembly

### 4.3 Water Lube Assembly

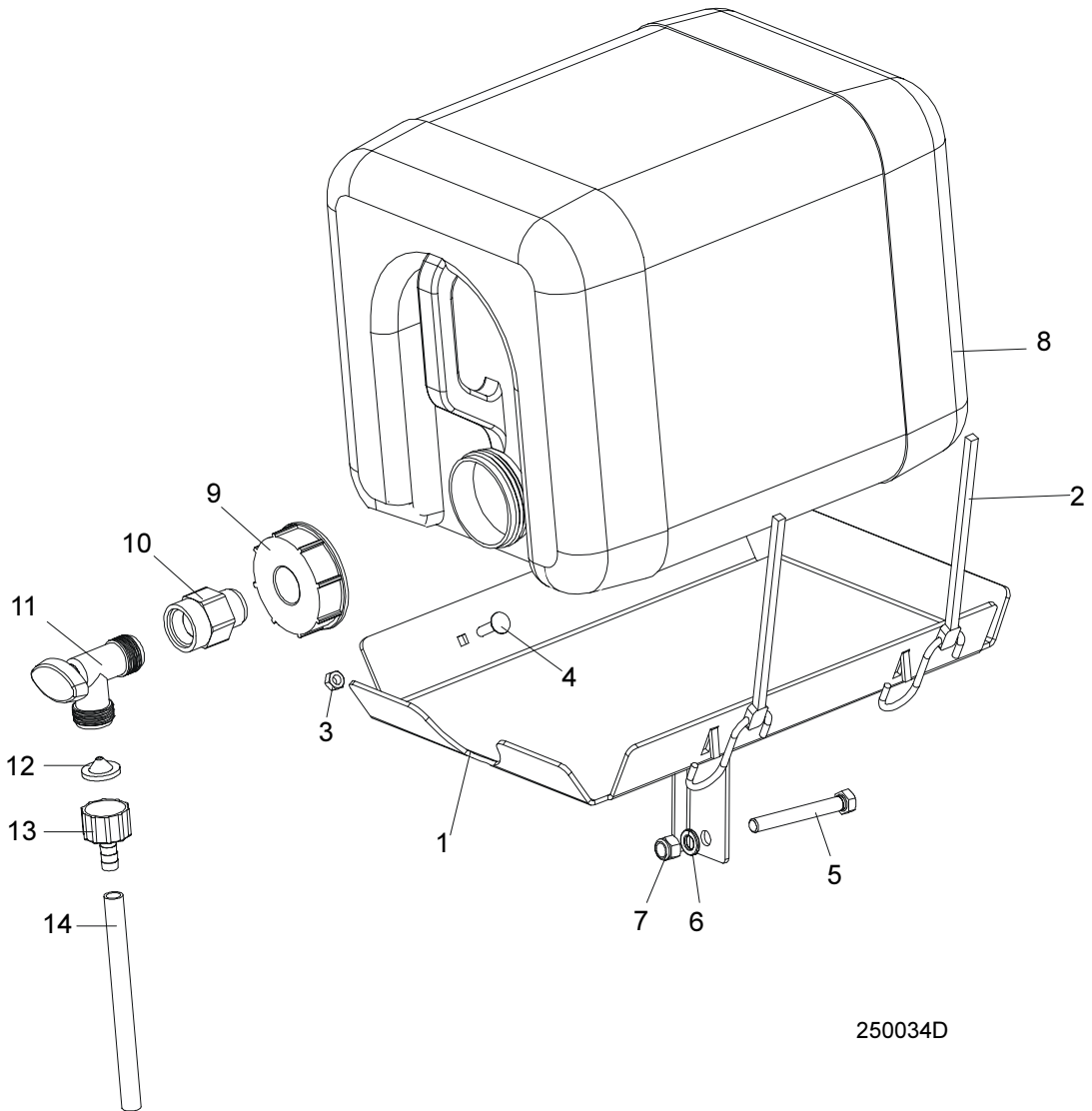

REF	DESCRIPTION (◆ Indicates Parts Available In Assemblies Only)	PART #	QTY.	
	<b>BOTTLE KIT, LT25 WATER LUBE</b>	25WLS	1	
	Tray Assembly, LT25 Water Lube	015434	1	
1	Tray Weldment, LT25 Water Lube	015431	1	◆
2	Strap, 20" Rubber	P11668	2	
3	Nut, 1/4-20 Hex Lock	F05010-21	2	
4	Bolt, 1/4-20 x 1" Carriage Head	F05005-34	2	
5	Bolt, M8x20-8.8-B-Zinc Hex Head Full Thread	F81002-4	2	
6	Washer 8,4-Zinc Round	F81054-1	2	
7	Nut, M8-8-B-Zinc Hex Nylon Lock	F81032-2	2	
	Bottle Assy, Water Lube	014642	1	
8	Bottle, 5-Gallon Water Lube	014637	1	◆

<b>9</b>	Cap, Water Lube Bottle Buttress Thread	014773	1	
<b>10</b>	Fitting, 3/4FPT x 3/4MPT	014636	1	
<b>11</b>	Fitting, Water Lube Shutoff Valve	014100	1	
<b>12</b>	Filter, Water Lube	016086	1	
<b>13</b>	Fitting, 5/8" NPT to 3/8" Hose Barb	014113	1	
<b>14</b>	Tubing, Water Lube 3/8" I.D.	R01885	2.1 m	

## 4.4 Saw Head Decals

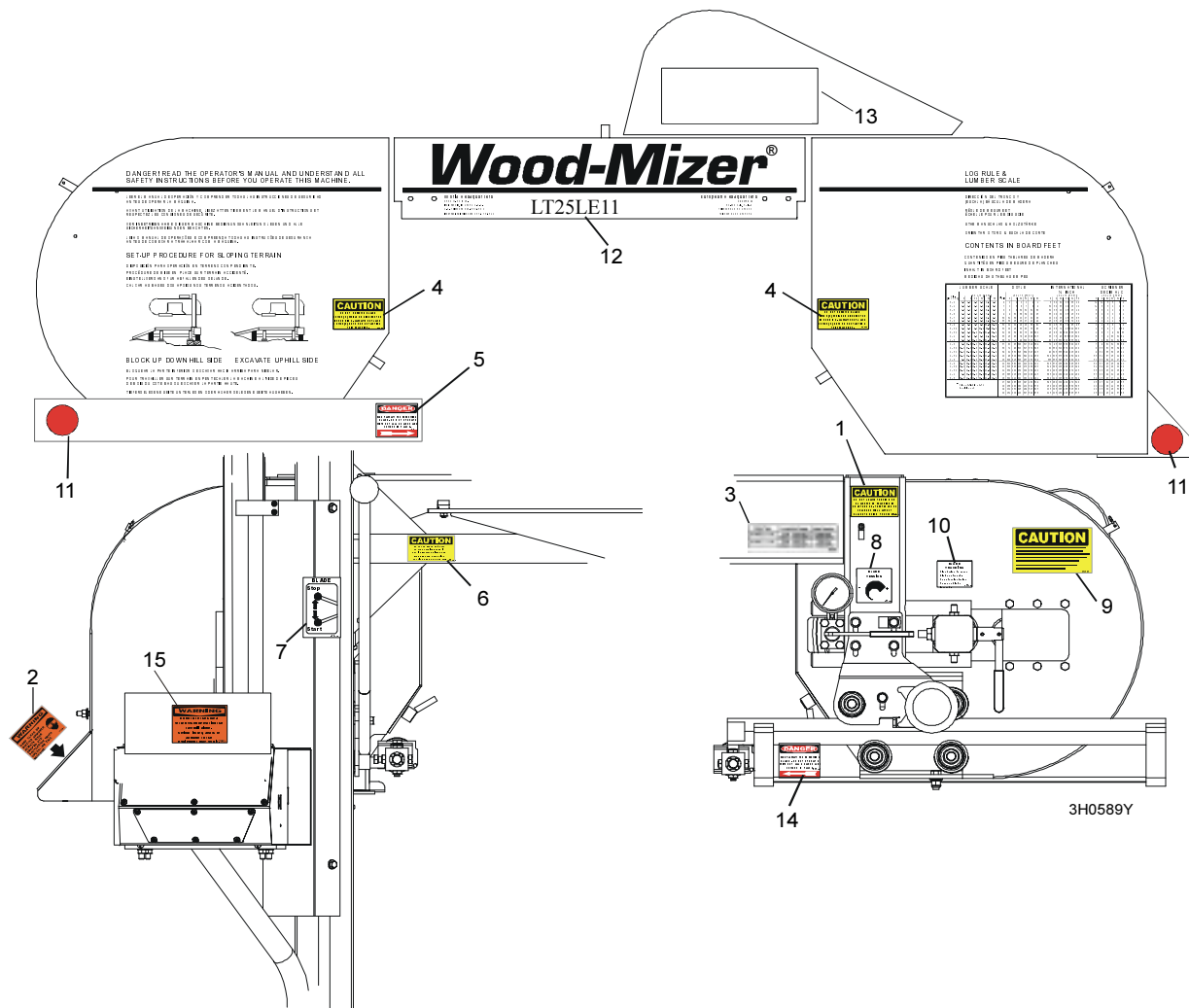

REF	DESCRIPTION (◆ Indicates Parts Available In Assemblies Only)	PART #	QTY.
1	DECAL, BLADE TENSION CAUTION	P10147	1
2	DECAL, SAWDUST CHUTE WARNING	P11754	1
3	DECAL, BLADE TENSION RANGES	085080	1
4	DECAL, BLADE COVERS CAUTION	S20039	2
5	DECAL, BLADE DANGER ARROW RIGHT	S11752	1
6	DECAL, UP/DOWN CAUTION	S11762	1
7	DECAL, BLADE START/STOP	P11779	1
8	DECAL, BLADE TENSION INFO	P11790	1
9	DECAL, SECURE THE SAW HEAD (PORTABLE SAWMILL ONLY)	S12581	1
10	DECAL, BLADE ALIGNMENT INFO	P11789	1
11	DECAL, RED REFLECTIVE 2" ROUND (PORTABLE SAWMILL ONLY)	P07452	2
12	DECAL, SAWMILL TYPE	N/A	
	Decal, LT25E11S	086885	1
	Decal, LT25G15S	086886	1



	Decal, LT25LE15S	086888	1	
	Decal, LT25LG15S	086889	1	
<b>13</b>	<b>DECAL, WOOD-MIZER WHAT'S IN A NAME</b>	S12528	1	
<b>14</b>	<b>DECAL, BLADE DANGER ARROW LEFT</b>	S11751	1	
<b>15</b>	<b>DECAL, EYE/EAR PROTECTION WARNING</b>	S11753	1	

### 4.5 Blade Housing Covers

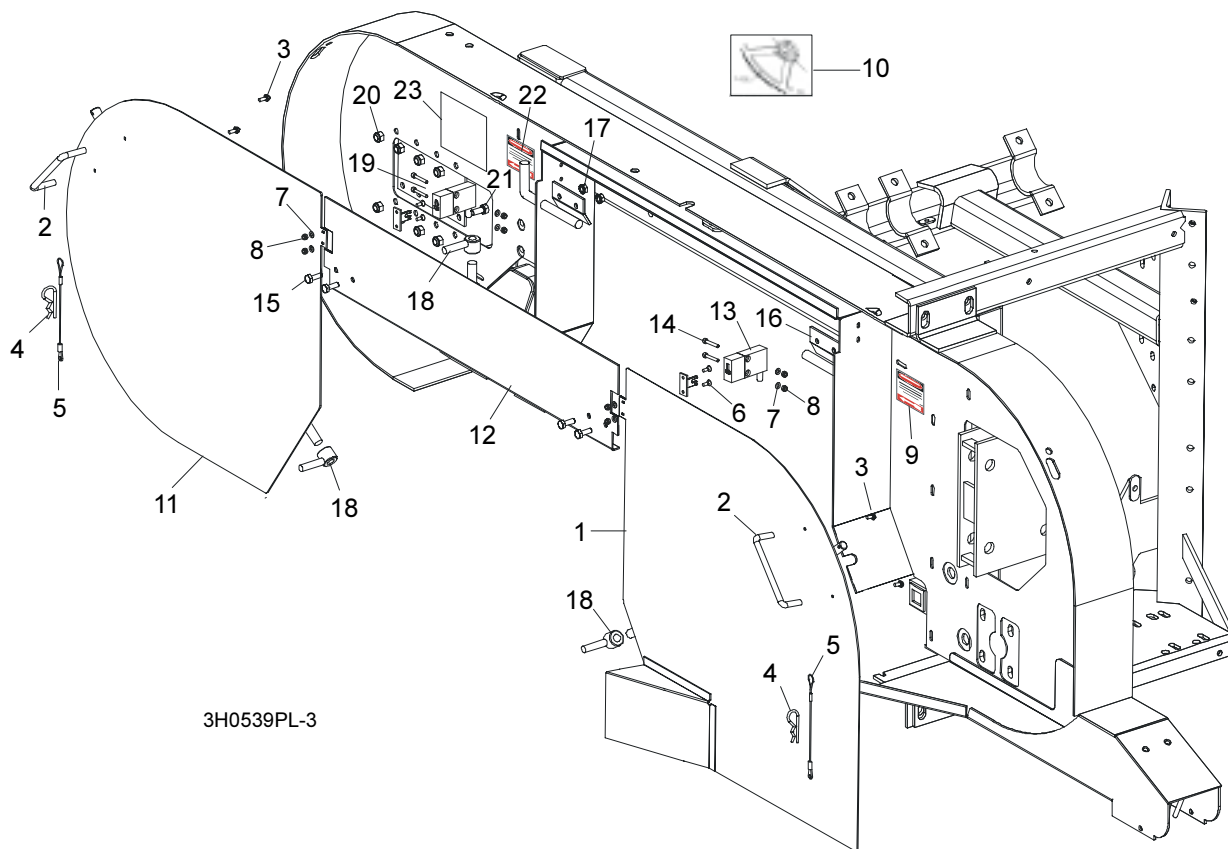

3H0539PL-3

REF	DESCRIPTION (◆ Indicates Parts Available In Assemblies Only)	PART #	QTY.	
	<b>COVER ASSEMBLY, DRIVE SIDE BLADE HOUSING WITH HANDLE</b>	086195	1	
1	Cover Weldment, Drive Side Blade Housing	086194-1	1	◆
2	Handle, Blade Housing Cover	P08065	1	
3	Screw, 21 Self-Tap	F81059-2	2	
	Pin Assembly, Cover Retainer	A11881	1	
4	Pin, Safety Retainer	N/A	1	
5	Cable, 3/64" x 6" Lanyard	N/A	1	
6	Bolt, M4 x 12-5.8	F81011-41	2	
7	Washer, 4.3	F81051-2	4	
8	Nut, M4 Hex	F81029-1	2	
9	<b>DECAL, BLADE DANGER W/ARROW</b>	S11751	2	
10	<b>DECAL, BLADE SETTING</b>	P85066	1	
	<b>COVER, IDLE SIDE BLADE HOUSING WITH HANDLE</b>	086431	1	
11	Cover, Idle Side Blade Housing	086430-1	1	◆
2	Handle, Blade Housing Cover	P08065	1	
3	Screw, #8-32 X 3/8" Self-Tap	F05015-8	2	

	Pin Assembly, Cover Retainer	A11881	1	
4	Pin, Safety Retainer	N/A	1	
5	Cable, 3/64" x 6" Lanyard	N/A	1	
8	Screw, M4 x 12-5.8	F81011-41	2	
9	Washer, 4.3 Flat	F81051-2	4	
10	Nut, M4 Hex	F81029-1	2	
12	<b>COVER, MIDDLE BLADE HOUSING</b>	086425-1	1	
13	Switch, Emergency Stop	087650	2	
14	Bolt, M4 x 20-8.8 Socket Head	F81011-31	4	
15	<b>BOLT, 1/4-20 X 3/4" HEX HEAD</b>	F05005-1	18	
16	<b>HINGE, MIDDLE BLADE HOUSING COVER</b>	S07522	2	
17	<b>NUT, 1/4-20 SELF-LOCKING HEX</b>	F05010-9	4	
18	<b>NUT, COVER TURN</b>	086076	3	
19	<b>PLATE, IDLE BLADE WHEEL GUARD</b>	086230	1	
20	<b>NUT, 5/16-18 HEX NYLON LOCK</b>	F05010-58	6	
21	<b>BOLT, 5/16-18 X 3/4" HEX HEAD GRADE 2</b>	F05006-5	6	

### 4.6 Drive Belt Covers

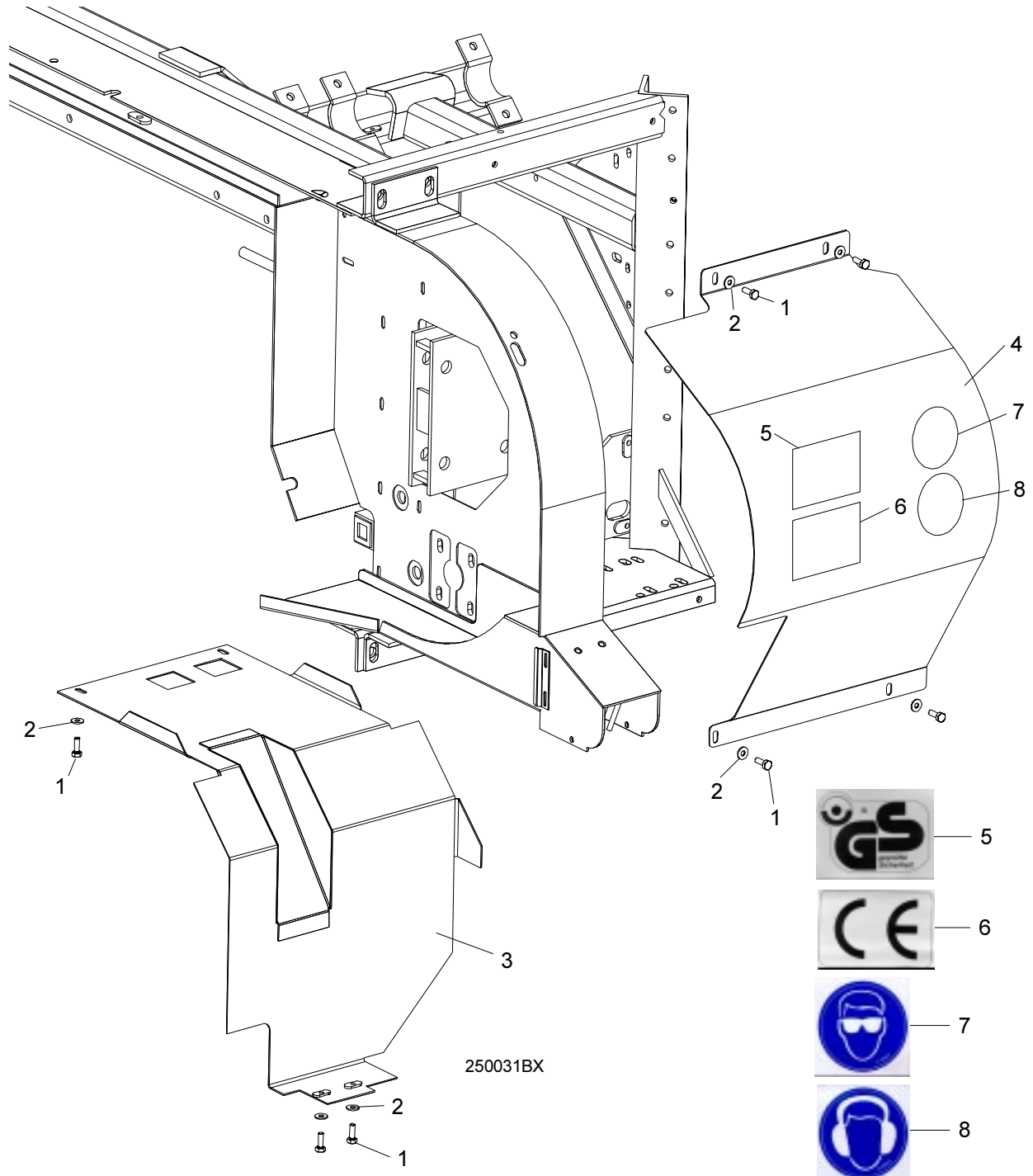

REF	DESCRIPTION (◆ Indicates Parts Available In Assemblies Only)	PART #	QTY.	
1	BOLT, M6X12-8.8-ZINC	F81001-7	8	
2	WASHER 6,5 ZINC	F81053-11	8	
3	GUARD, CLUTCH LEVER STANDARD	014241 <sup>1</sup>	1	
4	GUARD, DRIVE PULLEY BELT	086487-1	1	

5	<b>DECAL, GS SAFETY CERTIFICATION</b>	P85073	1	
6	<b>DECAL, CE CRTIFIED SAWMILL</b>	P85071	1	
7	<b>DECAL, EYE PROTECTION WARNING</b>	S12004G	1	
8	<b>DECAL, EAR PROTECTION WARNING</b>	S12005G	1	

<sup>1</sup> Different belt guards required if sawmill is equipped with autoclutch option. [See Section . .](#) of the Autoclutch Option manual.

# 4 Saw Head

## Sawdust Chute

### 4.7 Sawdust Chute

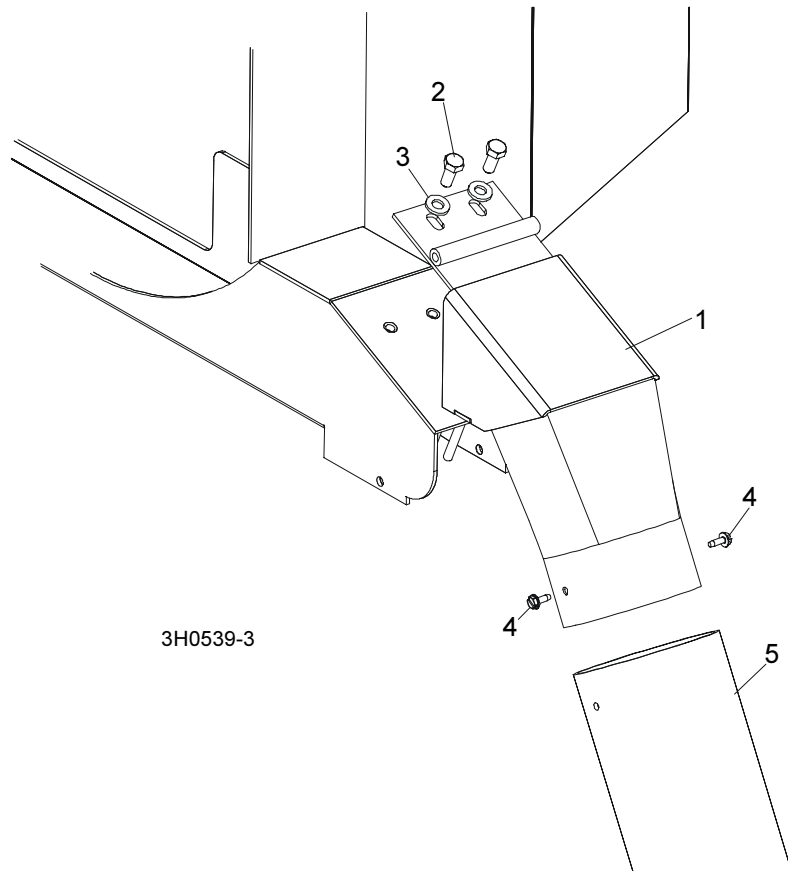

REF	DESCRIPTION (◆ Indicates Parts Available In Assemblies Only)	PART #	QTY.	
1	CHUTE WELDMENT, SAWDUST	015466	1	
2	BOLT, M8X20-8.8-B-ZINC HEX HEAD	F81002-4	2	
3	WASHER 8,4-ZINC ROUND	F81054-1	2	
4	BOLT, #10-24 X 1/2" SELF-TAPPING	F05015-7	2	
5	TUBING, 4" I.D. RUBBER	R02336	0.6 m	
	STRAP, 20" RUBBER W/HOOK	P11668	1	
	BOLT, 1/4-20 X 1 1/4" HEX HEAD FULL THREAD	F05005-3	1	
	WASHER, 7.4 FLAT	F81056-11	1	
	NUT, 1/4-20 LOCK	F05010-21	1	

## SECTION 5 UP/DOWN SYSTEM

### 5.1 Manual Up/Down Assembly

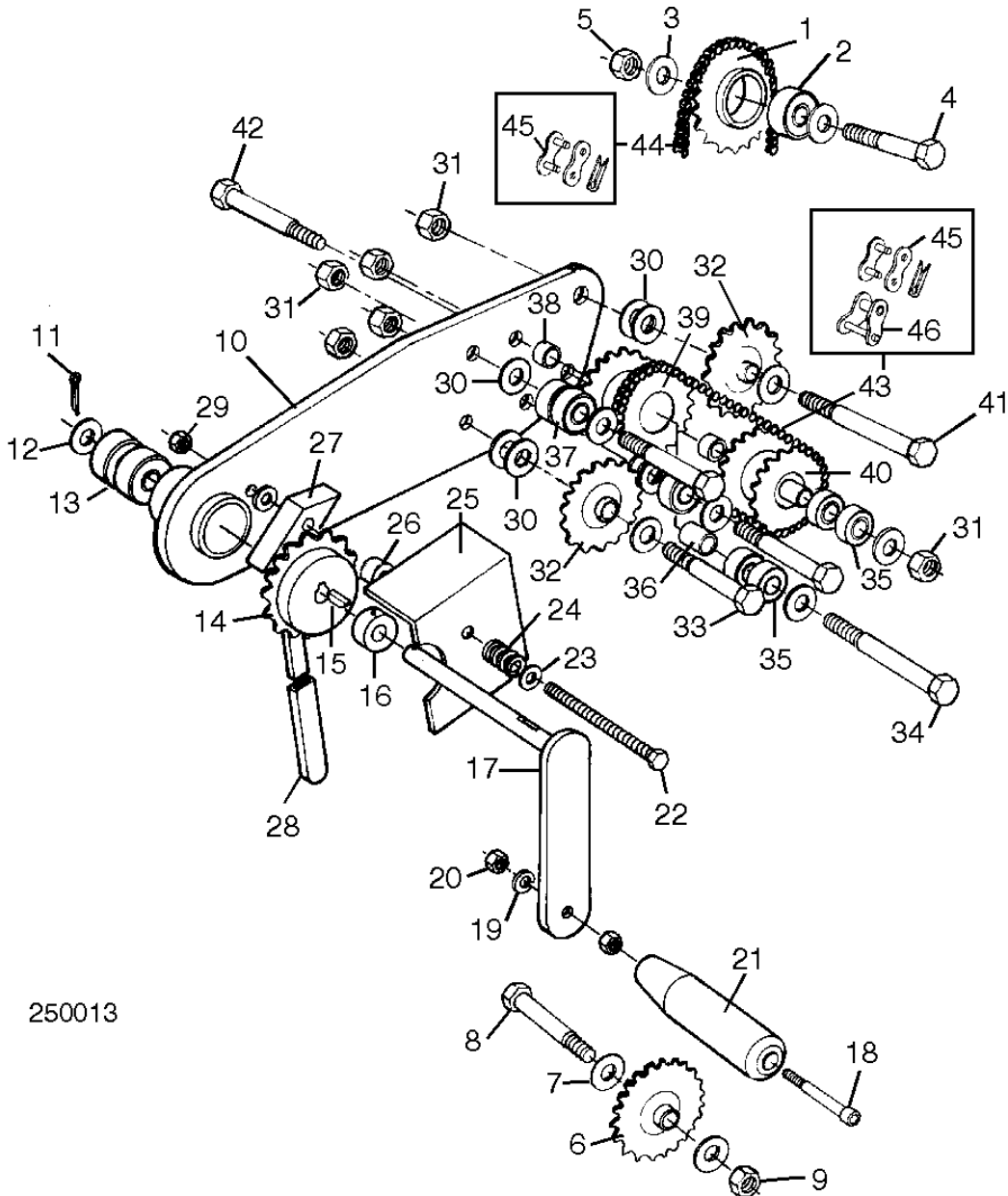

250013

REF	DESCRIPTION (◆ Indicates Parts Available In Assemblies Only)	PART NUMBER	QTY.	
	<b>SPROCKET ASSEMBLY, UPPER IDLER</b>	A12399	1	◆
1	Sprocket, Upper Idler With Hub	W12398	1	

# 5 Up/Down System

## Manual Up/Down Assembly

2	Bearing, 5/8" 6203-2NSL	P06030-1	1	
3	<b>WASHER, 17 ZINC ROUND</b>	F81058-1	2	
4	<b>BOLT, 5/8-11 X 2 1/2" HEX HEAD GRADE 5</b>	F05009-20	1	
5	<b>NUT, 5/8-11 HEX LOCK</b>	F05010-4	1	
6	<b>SPROCKET, G1-40-41-17 5/8" BORE 17T</b>	P04333	1	
7	<b>WASHER, 17 ZINC ROUND</b>	F81058-1	2	
8	<b>BOLT, 5/8-11 X 2 1/2" HEX HEAD GRADE 5</b>	F05009-20	1	
9	<b>NUT, 5/8-11 HEX LOCK</b>	F05010-4	1	
	<b>CRANK ASSEMBLY, LT25 UP/DOWN</b>	086345	1	
10	Arm, LT25 Up/Down Crank Mounting	W12470	1	
11	Pin, 1/8" x 1" Cotter	F05012-1	1	
12	Washer, 17 Zinc	F81058-1	1	
13	Bearing, 5/8" 6203-2NSL	P06030-1	2	
14	Sprocket, 40B17 5/8" Bore	P12483	1	
15	Key, #606 Woodruff	P04101-1	1	
16	Collar, 5/8" I.D. With Set Screw	P05035	1	
	Handle Assembly, LT25 Up/Down Crank	A12335	1	
17	Crank, LT25 Up/Down	086314-1	1	◆
18	Bolt, 3/8-16 x 2 1/2" Socket Head	F05007-24	1	
19	Washer, 3/8" Split Lock	F05011-4	1	
20	Nut, 3/8-16 Hex	F05010-1	2	
21	Handle, Crank	086338	1	
22	Bolt, M10 X 70-8.8 Hex Head Full Thread	F81003-20	1	
23	Washer, 3/8" SAE Flat	F05011-3	2	
24	Spring, Up/Down Lock Lee #LC-045G-5MW	P12494	1	
25	Guard, Up/Down Lock	087992-1	1	
26	Spacer, Up/Down Lock	S12284-W	1	
27	Handle, LT25 Up/Down Lock	086552	1	
28	Sleeve, Vinyl Handle	P08072	1	
29	Nut, M10-8-B -Zinc Hex Nylon Lock	F81033-1	1	
30	Washer, 17 Zinc	F81058-1	9	
31	Nut, 5/8-11 Hex Lock	F05010-4	6	
32	Sprocket, G1-40-41-17 5/8" Bore 17T	P04333	2	
33	Bolt, 5/8-11 x 2 1/2" Hex Head	F05009-20	3	
34	Bolt, 5/8-11 x 3" Hex Head	F05009-18	1	
35	Bearing, R10-2NSL	P04156	4	
36	Spacer, 1"	S12479-W	2	
37	Bearing, 5/8" 6203-2NSL	P06030-1	3	
38	Spacer, 5/16"	S12480-W	2	
39	Sprocket, Dual 17T/17T	W12475	1	
40	Sprocket, Dual 17T/16T	W12477	1	
41	Bolt, 5/8-11 x 4 1/2" Hex Head	F05009-3	1	
42	Bolt, 5/8-11 x 5" Hex Head Grade 2	F05009-6	1	



<b>43</b>	<b>CHAIN, #40 X 15.5"</b>	P12496	1	
<b>44</b>	<b>CHAIN, #40 X 170.5"</b>	P12497	1	
<b>45</b>	<b>LINK, #40 MASTER</b>	P04200	2	
<b>46</b>	<b>LINK, #40 HALF</b>	P12495	1	



## SECTION 6 SAW HEAD MOUNT & SCALES

### 6.1 Saw Head V-Brace Mount

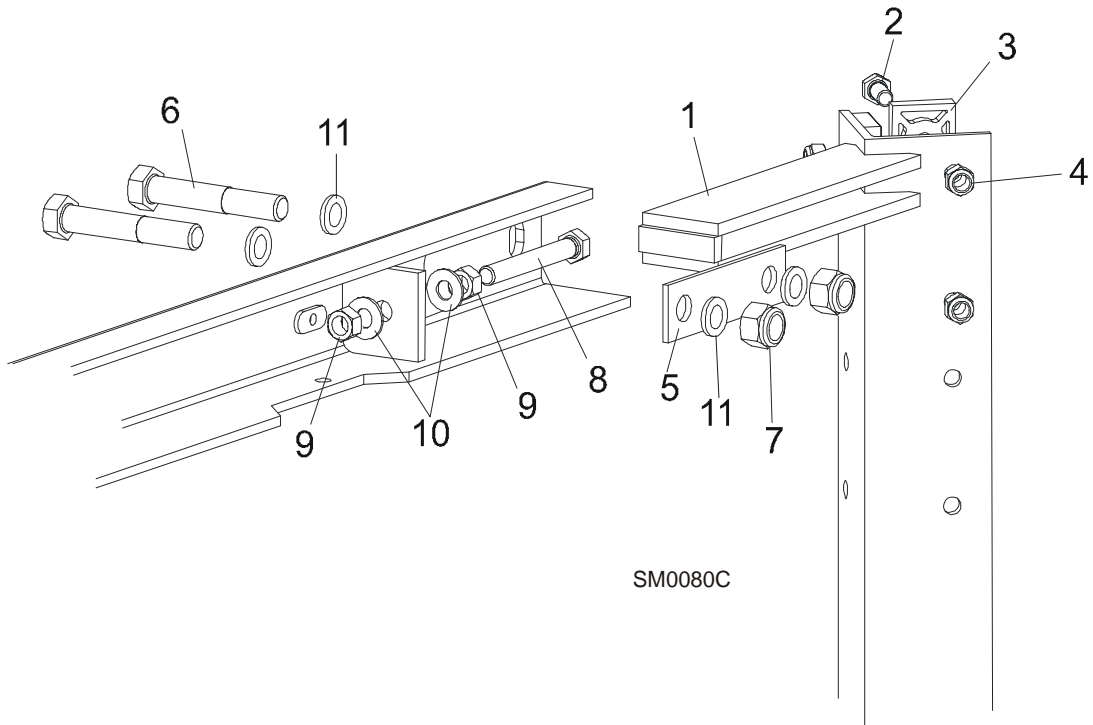

REF	DESCRIPTION (◆ Indicates Parts Available In Assemblies Only)	PART #	QTY.
1	V-BRACE, SAW HEAD MOUNT	087125	1
2	BOLT, M8X20-5.8-ZINC HEX HEAD	F81002-4	10
	BOLT, M8X25-8.8-B-ZINC HEX HEAD	F81002-5	2
3	PAD, PLASTIC SLIDE	M04096	6
4	NUT, M8-8-B-ZINC HEX NYLON LOCK	F81032-2	12
5	PLATE, V-BRACE WASHER	091247	2
6	BOLT, M12X75-8.8-ZINC	F81004-21	4
7	NUT, M12 - 8 NYLON LOCK	F81034-2	4
8	BOLT, M10X70-8.8-ZINC HEX HEAD	F81003-20	2
9	NUT, M10-8-B-ZINC HEX	F81033-3	4
10	WASHER, 10.5 FLAT	F81055-1	4
11	WASHER, 13 SPLIT LOCK ZINC	F81056-1	8

## 6.2 Blade Height Scale

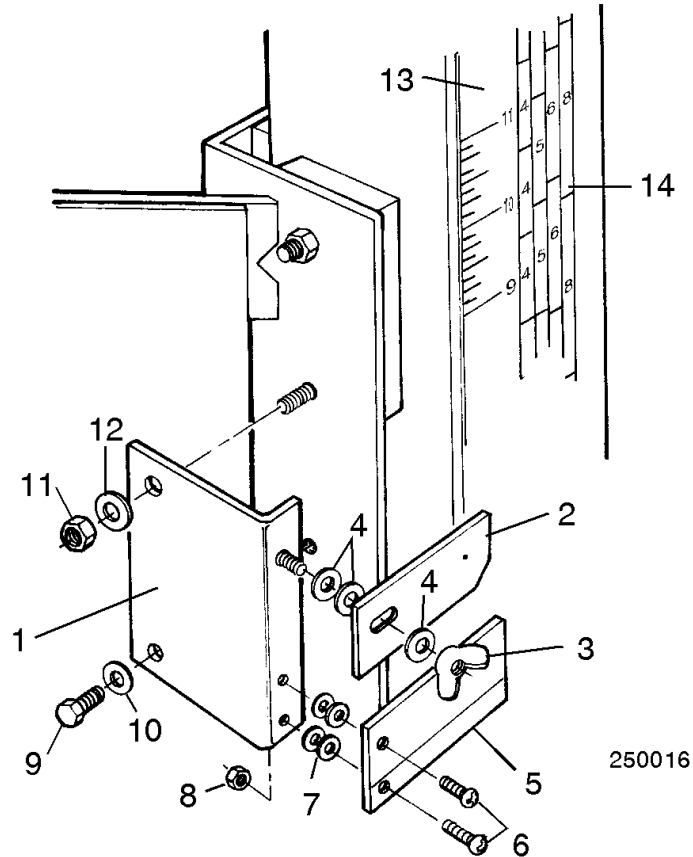

REF	DESCRIPTION (◆ Indicates Parts Available In Assemblies Only)	PART #	QTY.	
	<b>POINTER ASSEMBLY, LT25 BLADE HEIGHT</b>	A12414	1	
1	Bracket, Pointer Mount	086229-1	1	◆
2	Pointer, LT25 Quarter Scale	S12418	1	
3	Nut, 1/4-20 Wing	F05010-13	1	
4	Washer, 7.4 Flat	F81056-11	3	
5	Pointer, Lexan Blade Height	086691	1	
6	Screw, #10-24 x 3/8" Phillips Pan Head	F05004-3	2	
7	Washer, 5.3 Flat	F81052-1	4	
8	Nut, #10-24 Self Locking	F05010-14	2	
9	<b>BOLT, 1/4-20 X 1/2" HEX HEAD GRADE 2</b>	F05005-15	1	
10	<b>WASHER, 7.4 FLAT</b>	F81056-11	1	
11	<b>NUT, M8-8-B-ZINC HEX NYLON LOCK</b>	F81032-2	1	
12	<b>WASHER, 8.4 FLAT</b>	F81054-1	1	
13	<b>DECAL, 35" INCH SCALE</b>	P11038	1	
14	<b>DECAL, 35" QUARTER SCALE</b>	P11039	1	

## SECTION 7 TRACK ROLLERS

### 7.1 Upper Track Rollers And Wipers

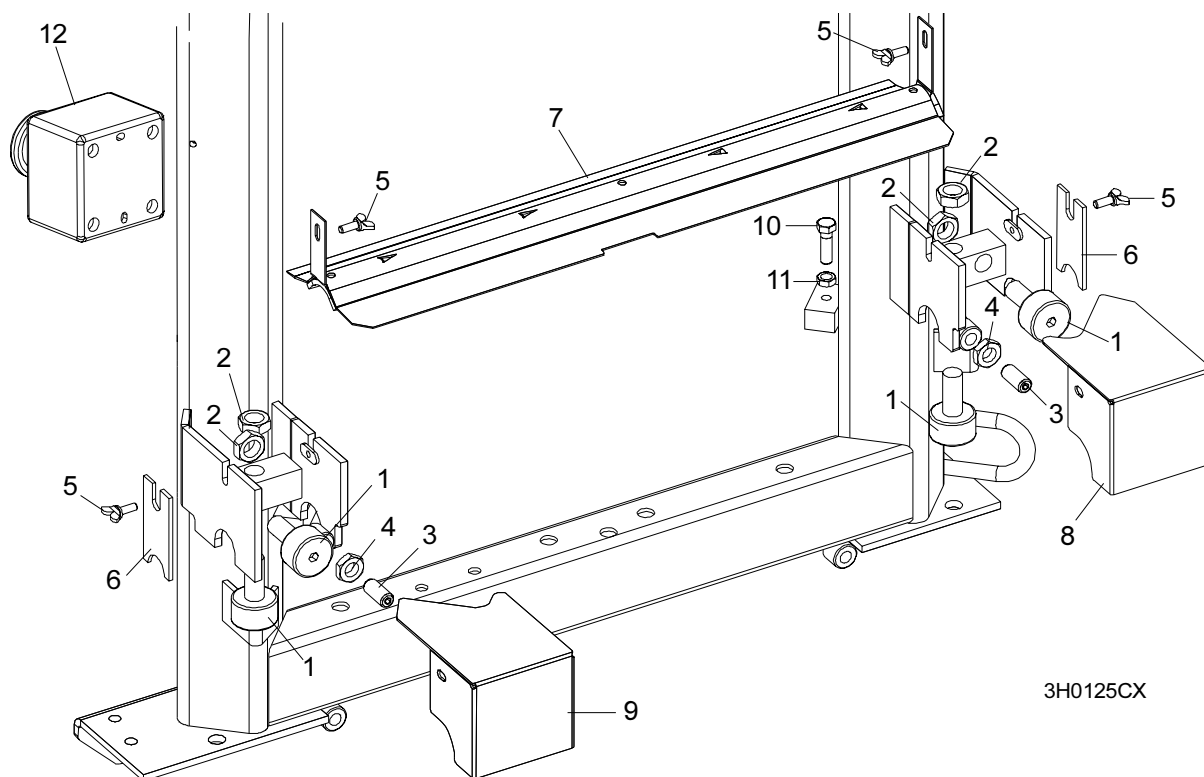

3H0125CX

REF	DESCRIPTION (◆ Indicates Parts Available In Assemblies Only)	PART #	QTY.	
1	ROLLER, TRACK CAM BEARING	012797	4	
2	NUT, 5/8-18 HEX JAM	F05010-11	4	
3	SCREW, M12 X 30 OVAL POINT SET	F81004-14	2	
4	NUT, M12-8-B HEX JAM	F81034-1	2	
5	SCREW, M6 X 16 THUMB	F81001-16	4	
6	WIPER, PLASTIC TRACK	M04113	2	
7	COVER, MIDDLE TRACK OILER	S09917	1	
	Wiper, Middle Track Felt	S09915	1	
8	HOUSING, UPPER TRACK ROLLER FRONT	086913-1	1	
9	HOUSING, UPPER TRACK ROLLER REAR	087307-1	1	
10	BOLT, M10 X 35-8.8 HEX HEAD	F81003-17	2	
11	NUT, M10 X 45-8.8 HEX JAM	F81003-3	2	
12	EMERGENCY STOP SWITCH	E22703-2	1	

## 7.2 Lower Track Rollers

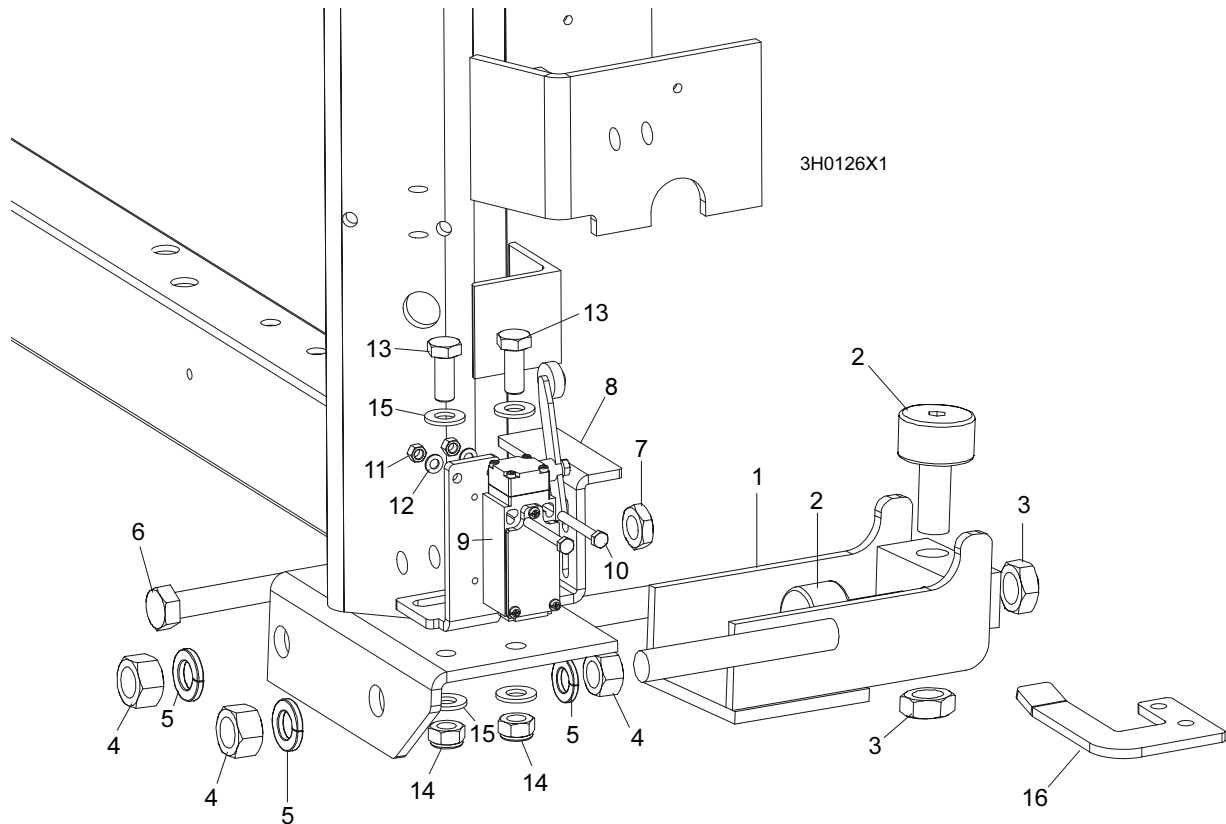

REF	DESCRIPTION (◆ Indicates Parts Available In Assemblies Only)	PART #	QTY.	
	<b>ROLLER ASSEMBLY, LOWER TRACK</b>	012995	2	
1	Bracket, Lower Track Roller Mounting	012982	1	◆
2	Roller, Track Cam Bearing	012797	2	
3	Nut, 5/8-18 Hex Jam	F05010-11	2	
4	Nut, 5/8-11 Hex	F05010-5	4	
5	Washer, 16.3 Split Lock	F81058-2	4	
6	<b>BOLT, M12 X 55-8.8 HEX HEAD FULL THREAD</b>	F81004-12	2	
7	<b>NUT, M12-8-B HEX JAM</b>	F81034-1	2	
8	<b>BRACKET, POWER SUPPLY STRIP AND LIMIT SWITCH</b>	086380-1	1	
9	<b>SWITCH, GLCB01A2B LIMIT</b>	086469	1	
10	<b>BOLT, M5 X 40 8.8 HEX HEAD</b>	F810000-11	2	
11	<b>NUT, M5-8</b>	F81030-1	2	
12	<b>WASHER, 5.3 FLAT</b>	F81052-1	2	
13	<b>BOLT, M10 X 25 8.8</b>	F81003-11	2	
14	<b>NUT, M10 NYLON</b>	F81033-1	2	
15	<b>WASHER, 10.5 FLAT</b>	F81055-1	2	
16	<b>BRACKET, LIMIT SWITCH</b>	086473-1	1	

## SECTION 8 BED FRAME ASSEMBLY

### 8.1 Bed Rail Assembly, Front And Rear

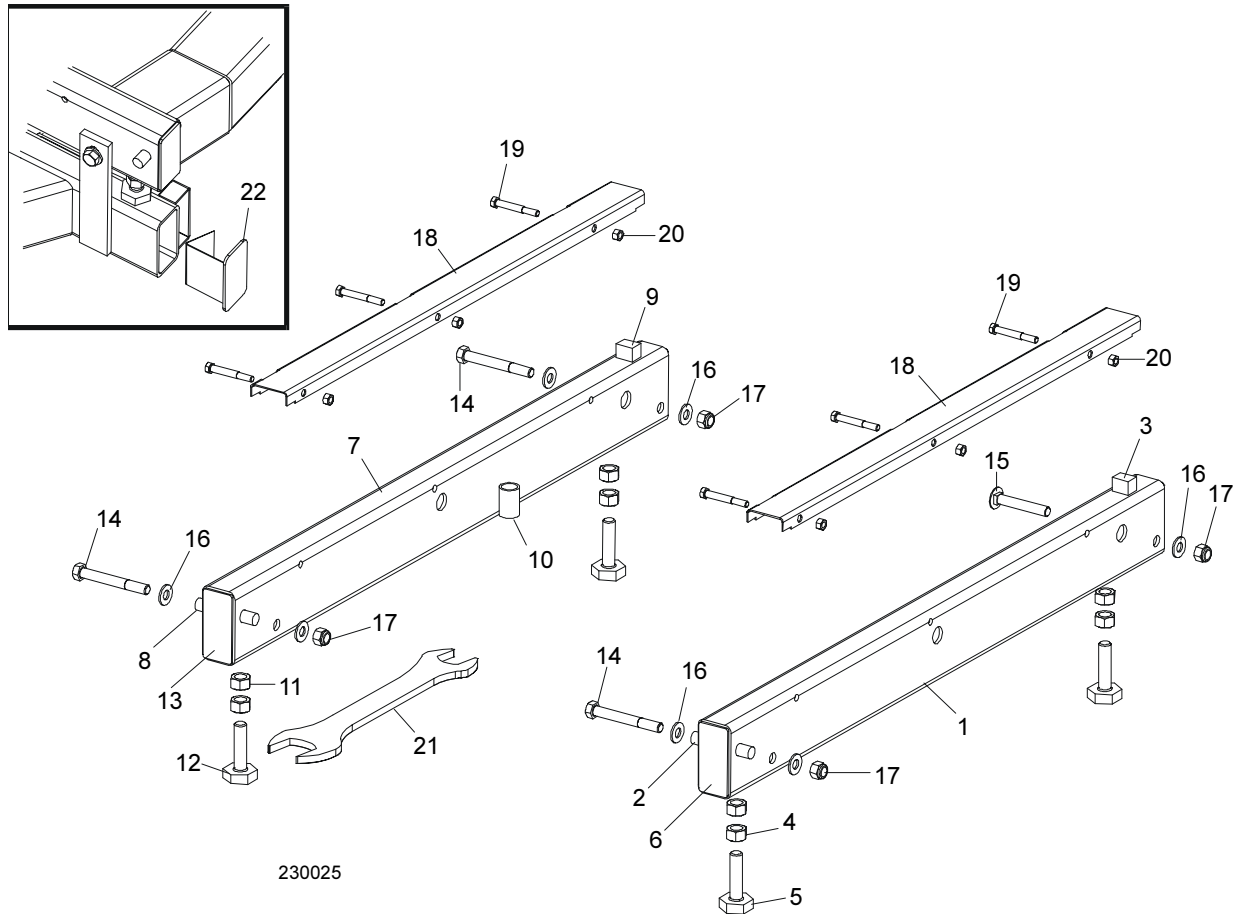

REF	DESCRIPTION (◆ Indicates Parts Available In Assemblies Only)	PART #	QTY.	
	<b>BED RAIL ASSEMBLY, REAR PAINTED</b>	A09774	1	
1	Bed Rail Tube, Long	S09102-0	1	◆
2	Pin, Ramp Mount	S04030	1	
3	Block, Log Stop	S09034	1	
	Bolt Assembly, Bed Rail	A09775	2	◆
4	Nut, 5/8-11 Hex	F05010-54	2	
5	Bolt, Bed Rail Adjustment	S13006	1	
6	Plate, Bed Rail End Cap	S04058-0	2	◆
	<b>BED RAIL ASSEMBLY, FRONT PAINTED</b>	A09564	1	
7	Bed Rail Tube, Long	S09102-0	1	◆
8	Pin, Ramp Mount	S04030	1	
9	Block, Log Stop	S09034	1	
10	Tube, Ramp Retainer Mount	S09334	1	◆
	Bolt Assembly, Bed Rail	A09775	2	◆
11	Nut, 5/8-11 Hex	F05010-54	2	

## 8

**Bed Frame Assembly***Bed Rail Assembly, Front And Rear*

12	Bolt, Bed Rail Adjustment	S13006	1	
13	Plate, Bed Rail End Cap	S04058	2	◆
14	<b>BOLT, 1/2-13 X 4" HEX HEAD</b>	F05008-26	3	
15	<b>BOLT, 1/2-13 X 3 1/2" CARRIAGE</b>	F05008-94 <sup>1</sup>	1	
16	<b>WASHER, 13 FLAT</b>	F81056-1	7	
17	<b>NUT, M12-8 HEX NYLON LOCK</b>	F81034-2	4	
	<b>COVER ASSEMBLY, STAINLESS STEEL BED RAIL (LONG)</b>	A09956	2	
18	Cover, Stainless Steel Bed Rail	S09944	1	◆
19	Bolt, M8x65-5,8 Zinc Hex Head	F81002-3	6	
20	Nut, M8-8-B-Zinc Hex Nylon Lock	F81032-2	6	
21	<b>WRENCH, BED RAIL ADJUSTMENT</b>	015970	1	
22	<b>CAP WELDMENT, BED RAIL REMOVABLE END</b>	014652	2	

<sup>1</sup> Used on rear bed rail to allow clearance for optional side support rollers.



## 8.2 Bed Rail Assembly, Front Middle

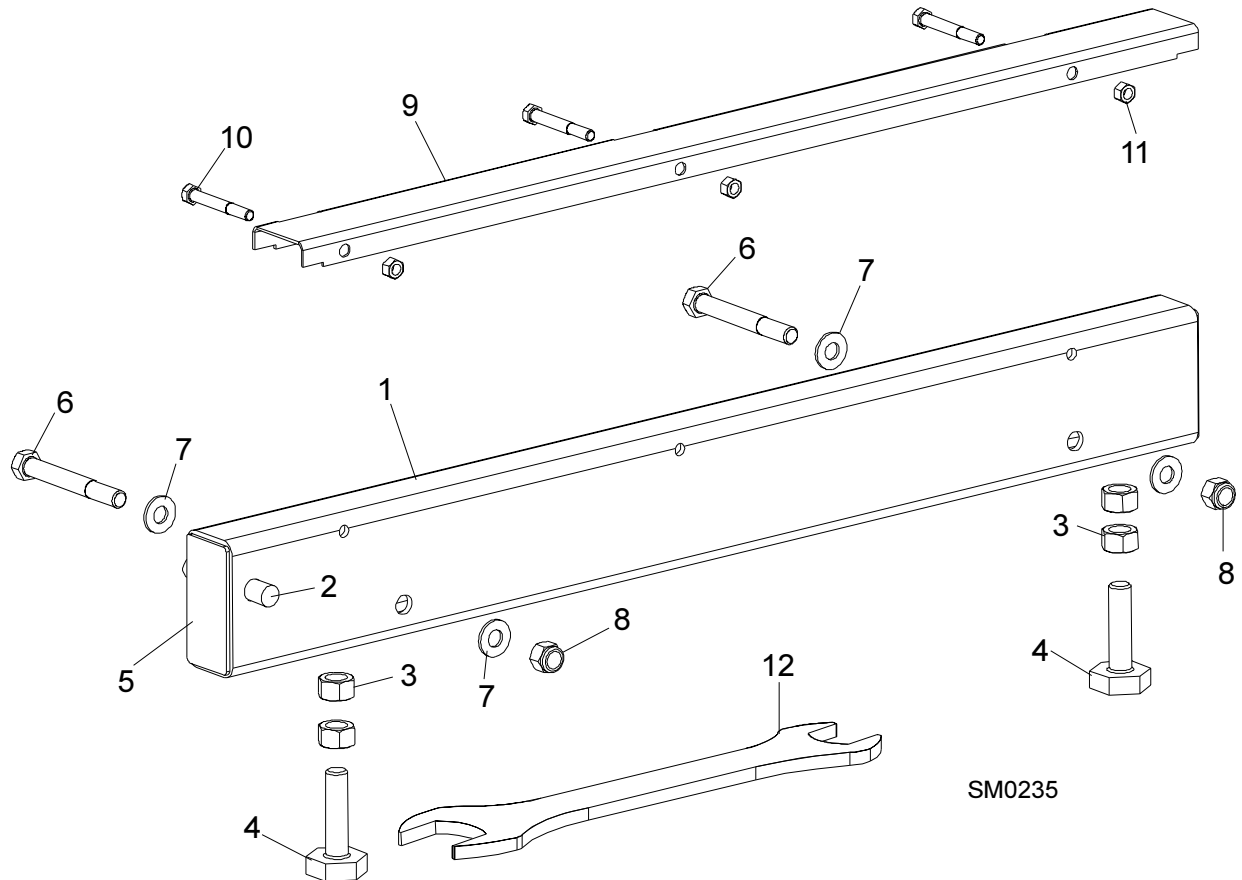

REF	DESCRIPTION (◆ Indicates Parts Available In Assemblies Only)	PART #	QTY.	
	<b>BED RAIL ASSEMBLY, FRONT MIDDLE</b>	A09566	1	
1	Bed Rail Tube, Short	S09103	1	◆
2	Pin, Ramp Mount	S04030	1	
	Bolt Assembly, Bed Rail	086809	2	◆
3	Nut, 5/8-11 Hex	F05010-54	2	
4	Bolt, Bed Rail Adjustment	S13006	2	
5	Plate, Bed Rail End Cap	S04058	2	◆
6	<b>BOLT, M12 X 100-8.8 HEX HEAD</b>	F81004-3	2	
7	<b>WASHER, 13 FLAT</b>	F81056-1	4	
8	<b>NUT, M12-8 HEX NYLON LOCK</b>	F81034-2	2	
	<b>COVER ASSEMBLY, STAINLESS STEEL BED RAIL (LONG)</b>	A09956	1	
9	Cover, Stainless Steel Bed Rail	S09944	1	◆
10	Bolt, M8x65-5,8 Zinc Hex Head	F81002-3	3	
11	Nut, M8-8-B-Zinc Hex Nylon Lock	F81032-2	3	
12	<b>WRENCH, BED RAIL ADJUSTMENT</b>	015970	1	

# 8 Bed Frame Assembly

## Bed Rail Assembly, Rear Middle

### 8.3 Bed Rail Assembly, Rear Middle

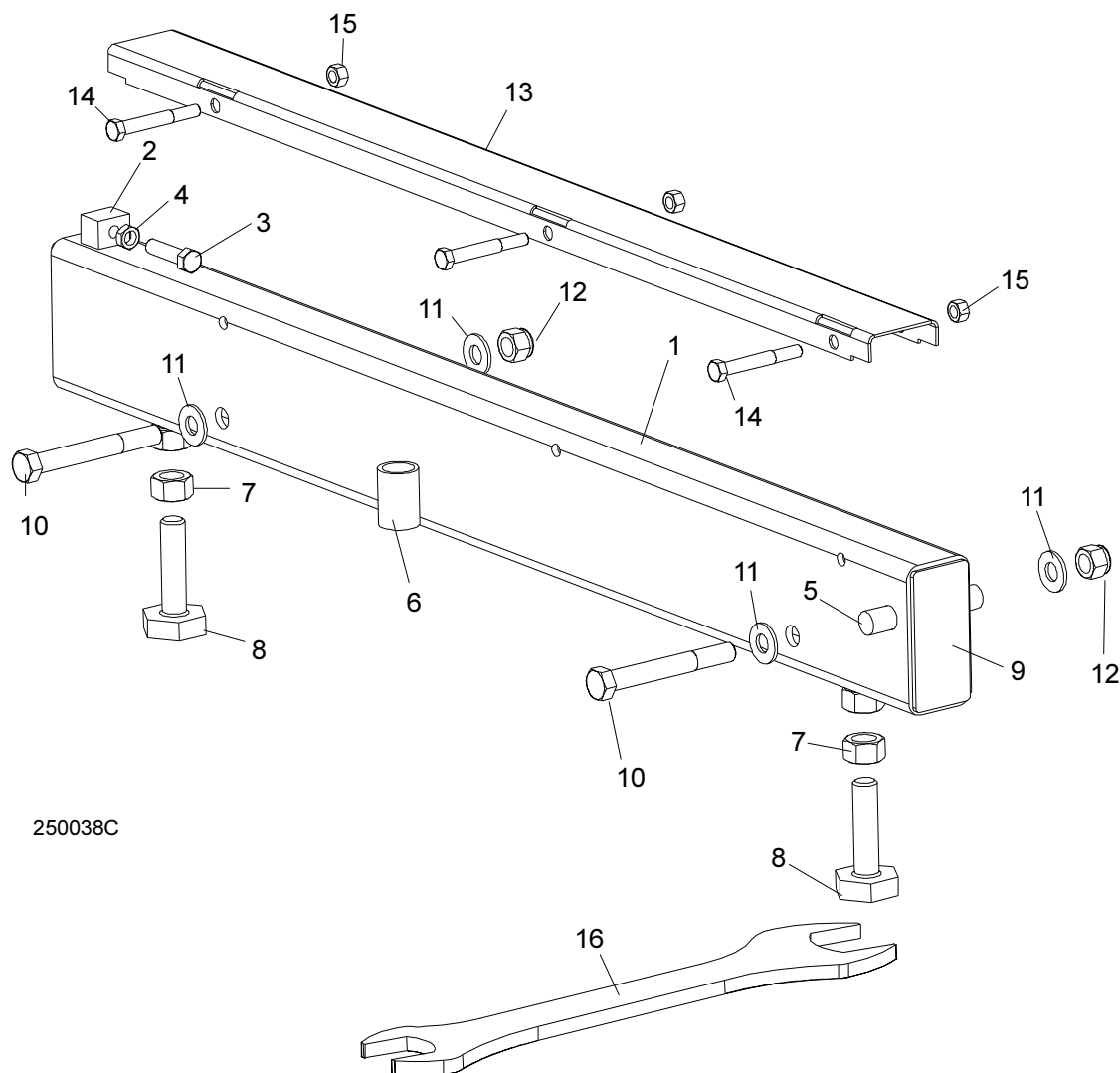

250038C

REF	DESCRIPTION (◆ Indicates Parts Available In Assemblies Only)	PART #	QTY.	
	<b>BED RAIL ASSEMBLY, REAR MIDDLE</b>	A09565	1	
1	Bed Rail Tube, Short	014640	1	◆
2	Block, Log Stop w/Threaded Hole	014639	1	◆
3	Bolt, 3/8-16 x 1 1/2 Full Thead Hex Head	F05007-17	1	
4	Nut, 3/8-16 Hex Jam	F05010-29	1	
5	Pin, Ramp Mount	S04030	1	
6	Tube, Ramp Retainer Mount	S09334	1	◆
	Bolt Assembly, Bed Rail	A09775	2	◆
7	Nut, 5/8-11 Hex	F05010-54	2	
8	Bolt, Bed Rail Adjustment	S13006	2	
9	Plate, Bed Rail End Cap	S04058	2	◆
10	<b>BOLT, M12 X 100-8.8 HEX HEAD</b>	F81004-3	2	
11	<b>WASHER, 13 FLAT</b>	F81056-1	4	

<b>12</b>	<b>NUT, M12-8 NYLON LOCK</b>	F81034-2	2	
	<b>COVER ASSEMBLY, STAINLESS STEEL BED RAIL (LONG)</b>	A09956	1	
<b>13</b>	Cover, Stainless Steel Bed Rail	S09944	1	◆
<b>14</b>	Bolt, M8x65-5,8 Zinc Hex Head	F81002-3	3	
<b>15</b>	Nut, M8-8-B-Zinc Hex Nylon Lock	F81032-2	3	
<b>16</b>	<b>WRENCH, BED RAIL ADJUSTMENT</b>	015970	1	

# 8 Bed Frame Assembly

Leg, Stationary

## 8.4 Leg, Stationary

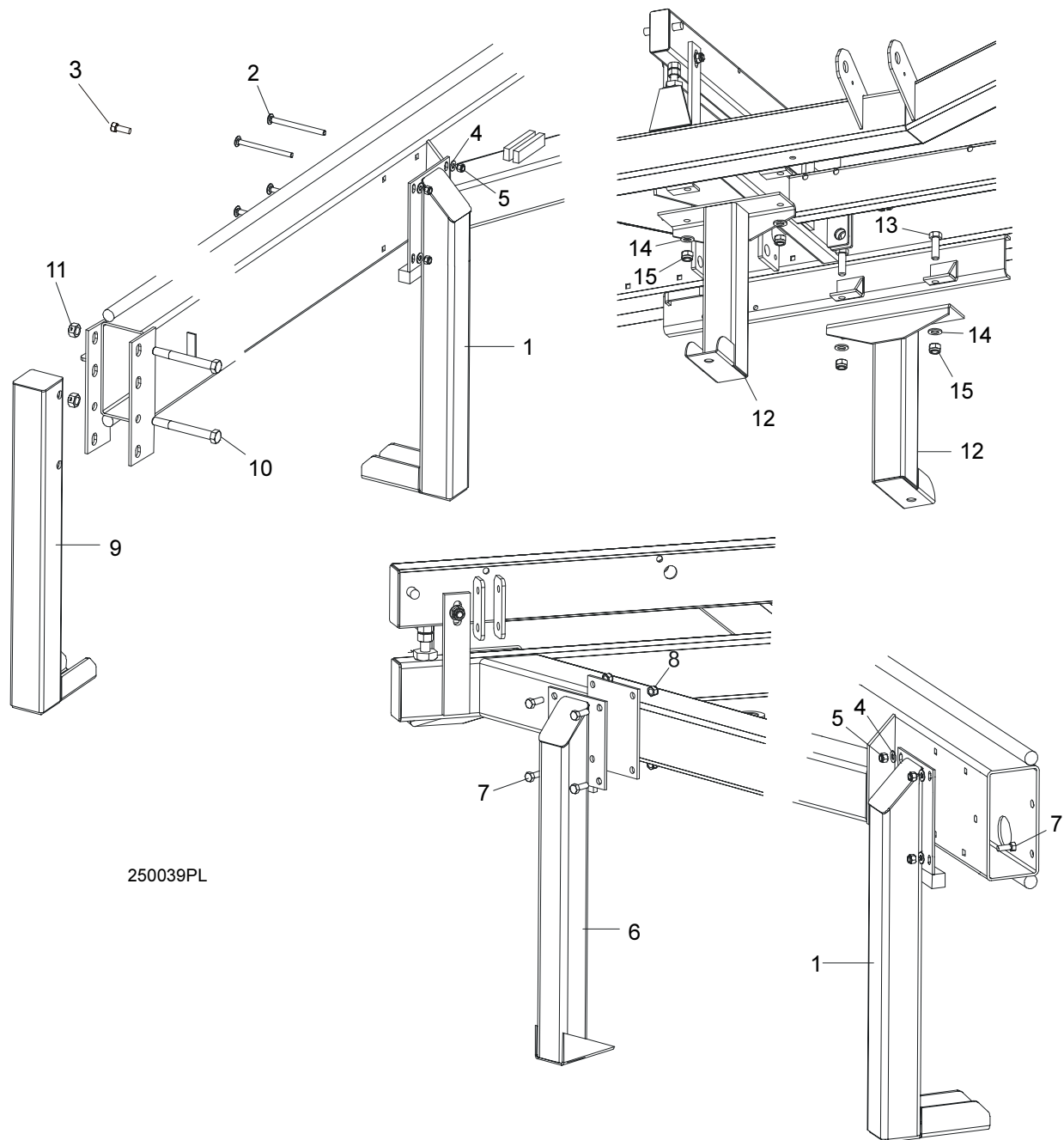

REF	DESCRIPTION (◆ Indicates Parts Available In Assemblies Only)	PART #	QTY.
1	LEG, LONG STATIONARY (2 REQ'D FOR LT25; 3 REQ'D FOR LT25L)	087451-1	2/3
2	BOLT, M10 X 120-8.8 CARRIAGE HEAD	F81003-33	8
3	BOLT, 3/8-16 X 1" HEX HEAD GRADE 2 (REQ'D FOR REAR LT25L ONLY)	F05007-7	4
4	WASHER, 10.5 FLAT	F81055-1	16
5	NUT, M10-8-B HEX NYLON LOCK	F81033-1	8/12
6	LEG, SHORT STATIONARY	087450-1	2
7	BOLT, M10 X 25-8.8 HEX HEAD	F81003-11	12

**Bed Frame Assembly**  
*Leg, Stationary*

**8**

8	NUT, M10-8-B HEX NYLON LOCK	F81033-1	12	
9	LEG, FRONT STATIONARY	087452-1	1	
10	BOLT, M16 X 140-8.8 HEX HEAD	F81006-4	2	
11	NUT, M16-8 HEX LOCK	F81036-2	2	
12	LEG, MIDDLE STAIONARY	087093-1	2	
13	BOLT, M16 X 50-8.8 HEX HEAD	F81006-7	4	
14	WASHER, 17 FLAT	F81058-1	4	
15	NUT, M16 NYLON LOCK	F81036-2	4	

# 8 Bed Frame Assembly

## Pivot Bed Rail Assembly

### 8.5 Pivot Bed Rail Assembly

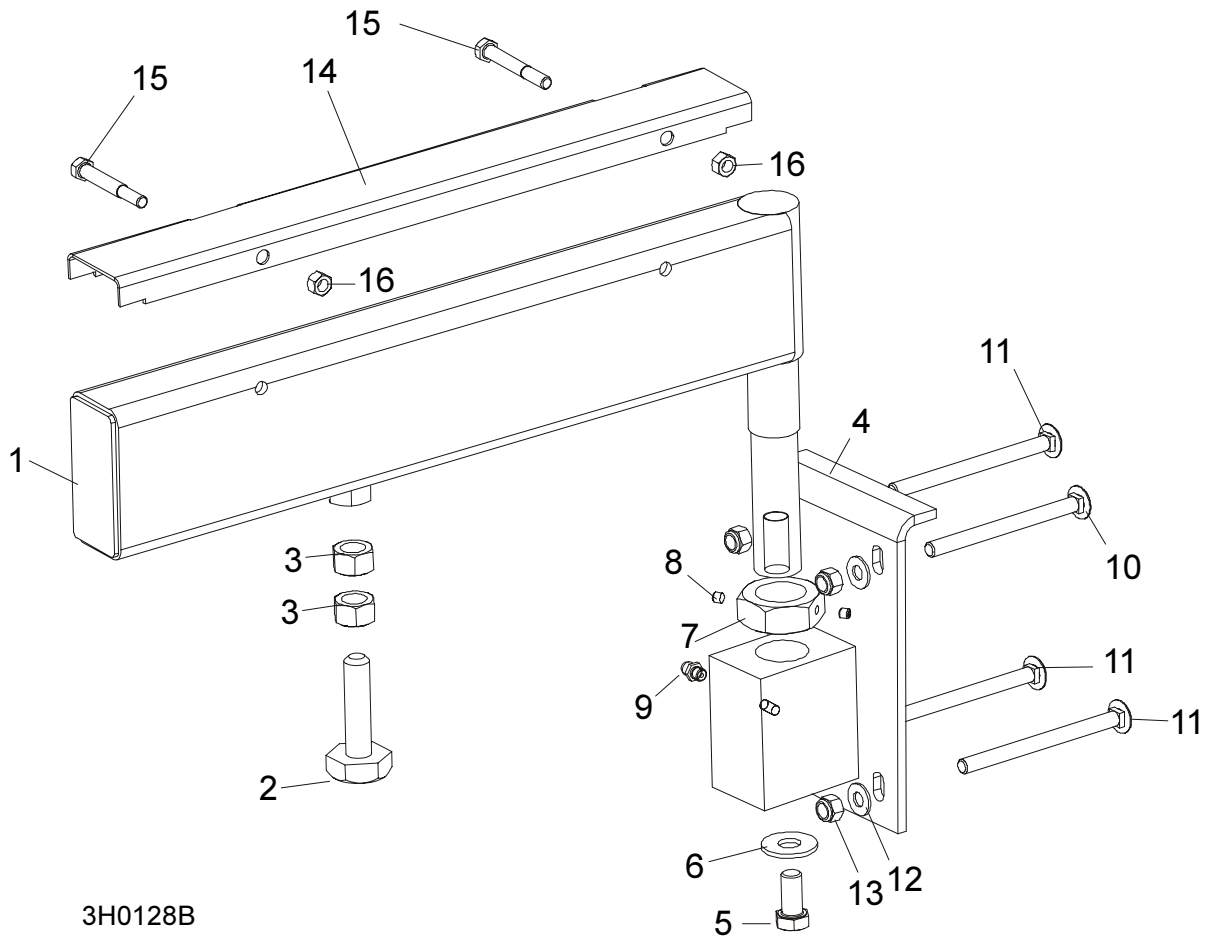

3H0128B

REF	DESCRIPTION (◆ Indicates Parts Available In Assemblies Only)	PART #	QTY.
	<b>PIVOT BED RAIL ASSEMBLY (LT25)</b>	087829	2
	<b>PIVOT BED RAIL ASSEMBLY (LT25L)</b>	087855	2
1	Pivot Bed Rail Weldment (LT25)	087852	1
	Pivot Bed Rail Weldment (LT25L)	087848	1
	Bolt Assembly, Bed Rail Adjustment		1
2	Bolt, Bed Rail Adjustment	086809	1
3	Nut, 5/8-11 Hex	F81036-1	2
4	Bracket, Pivot Rail Mounting	087841-1	1
5	Bolt, 1/2-13 x 1" Hex Head Grade 2	F81004-31	1
6	Washer, 15 Flat	F05011-52	1
7	Nut, Pivot Rail Adjustment (LT25) Nut, Pivot Rail Adjustment (LT25L)	F81036-1 F81039-2	1
8	Screw, 1/4-28 x 1/4" Brass Tip Set	F05005-42	2
9	Fitting, 3/16" Grease	086280	1
10	<b>BOLT, 3M10 X 120-8.8 CARRIAGE HEAD</b>	F81003-14	2
11	<b>BOLT, 3/8-16 X 5" CARRIAGE HEAD</b>	F05007-113	6

<b>12</b>	<b>WASHER,10.5 FLAT</b>	F81055-1	8	
<b>13</b>	<b>NUT, M16-8 NYLON LOCK</b>	F81036-2	8	
	<b>COVER KIT, PIVOT RAIL STAINLESS STEEL (LT25)</b>	015926	2	
	<b>COVER KIT, PIVOT RAIL STAINLESS STEEL (LT25L)</b>	N/A	2	
<b>14</b>	Cover, Stainless Steel Pivot Bed Rail (LT25)	012994	1	
	Cover, Stainless Steel Pivot Bed Rail (LT25L)	S13012	1	
<b>15</b>	Bolt, M8x65-5,8 Zinc Hex Head	F81002-3	4	
<b>16</b>	Nut, M8-8-B-Zinc Hex Nylon Lock	F81032-2	4	
	<b>WRENCH, BED RAIL ADJUSTMENT (<a href="#">See Section 8.3</a>)</b>	015970	1	

## 8.6 Log Side Support Assembly

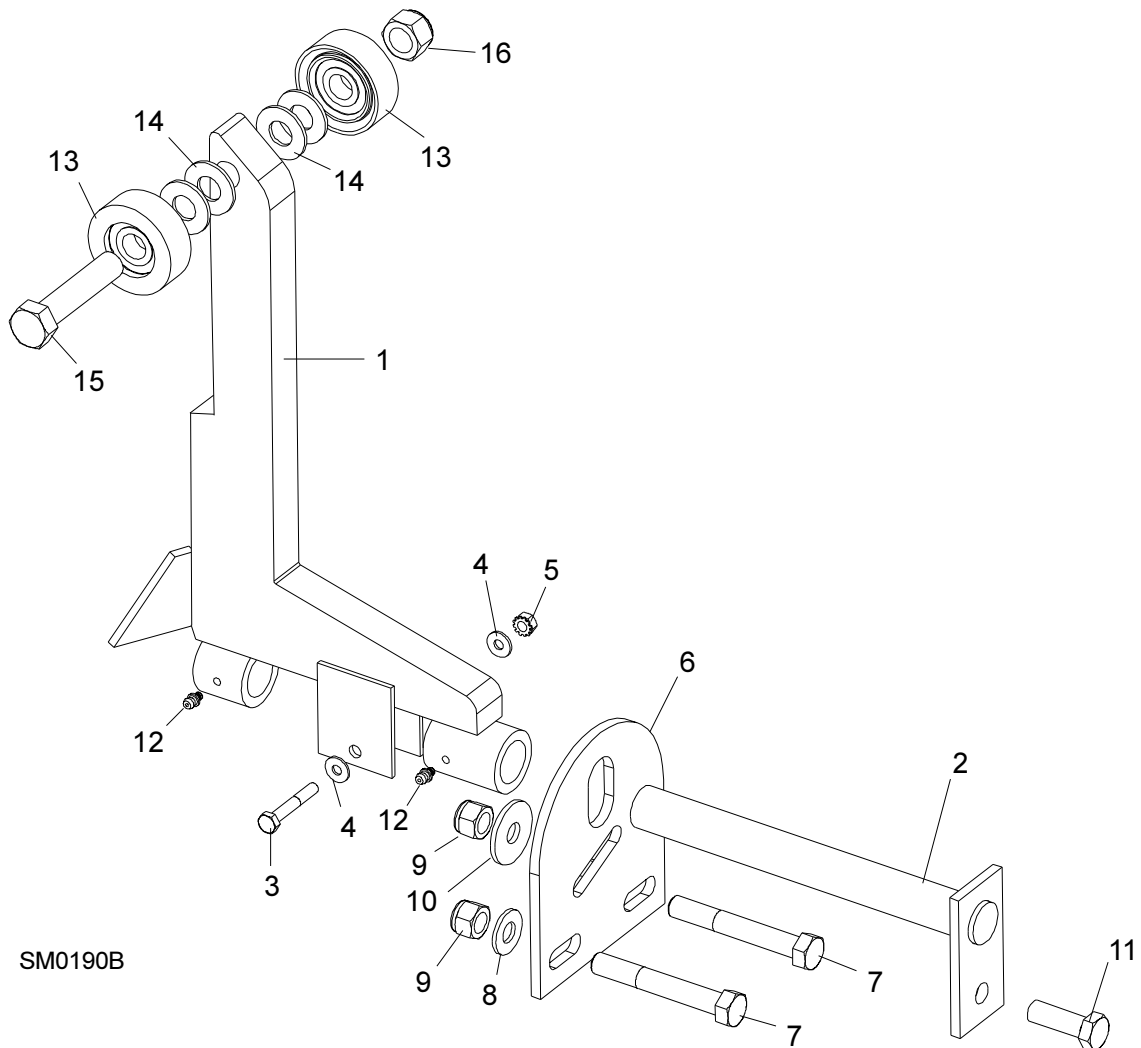

REF	DESCRIPTION (◆ Indicates Parts Available In Assemblies Only)	PART #	QTY.
1	<b>SUPPORT, LOG SIDE</b>	085538	4
	<b>MOUNTING KIT, LOG SIDE SUPPORT</b>	K09440	4
2	Pin, Log Side Support Pivot	W09238-1	1
3	Bolt, 1/4-20 X 1 1/2" Hex Head Grade 5	F05005-4	1
4	Washer, 7.4 Flat	F81056-11	2
5	Nut, 1/4-20 Self Locking	F05010-9	1
6	Plate, Log Side Support End	S09148	1
7	Bolt, M12 x 90-8.8 Hex Head	F81004-2	2
8	Washer, 13 Flat	F81056-1	2
9	Nut, M12-8 Hex Nylon Lock	F81034-2	3
10	Washer, .5" x 1.63" x 11" Ga.	086184	1
11	Bolt, M12 x 35-8.8 Hex Head	F81004-11	1



<b>12</b>	<b>FITTING, 3/16" GREASE</b>	P04107	2	
	<b>ROLLER KIT, SIDE SUPPORT (OPTIONAL)</b>	015109	4	
<b>13</b>	Roller Assembly, Side Support	015014-1	2	
<b>14</b>	Washer, 17 Flat	F81058-1	4	
<b>15</b>	Bolt, 5/8-11 x 3" Hex Head Grade 5	F05009-37	1	
<b>16</b>	Nut, 5/8-11 Nylon Lock	F05010-34	1	
	Instruction Sheet, Side Support Roller	015109-526	1	

### 8.7 Tie Down Chain Assembly

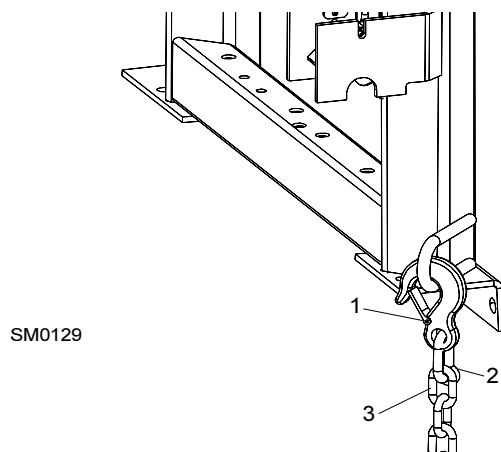

REF	DESCRIPTION (◆ Indicates Parts Available In Assemblies Only)	PART #	QTY.	
	<b>CHAIN ASSEMBLY, TIE DOWN</b>	A04376	1	
1	Hook, 5/8" Safety Chain	P12075	1	◆
2	Cold Shut, 3/8" Plain	P04772-2	1	◆
3	Chain, N-10 x 35 Unplated	R80558	.28 m	◆

## 8.8 Bed Frame Decals

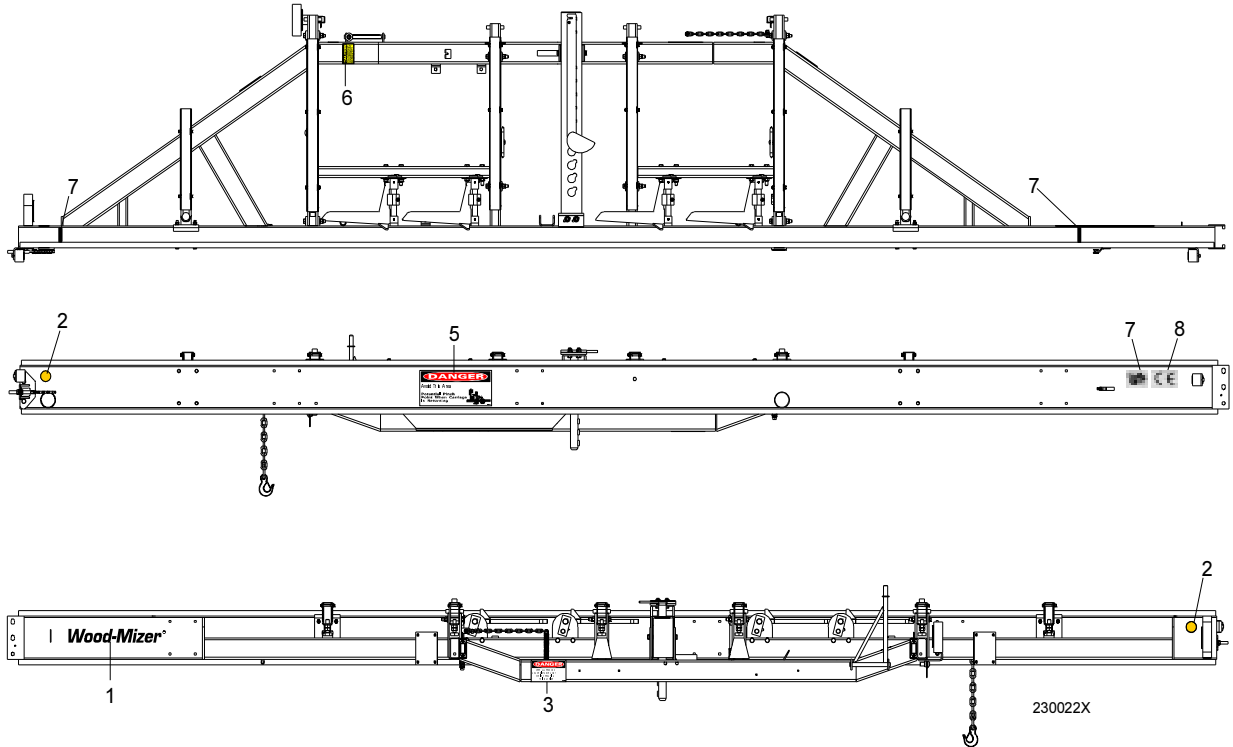

REF	DESCRIPTION (◆ Indicates Parts Available In Assemblies Only)	PART #	QTY.
1	DECAL, WOOD-MIZER LOGO	S12281	1
2	DECAL, AMBER REFLECTIVE 2" ROUND	P07453	2
3	DECAL, KEEP AWAY DANGER	S09851	1
4	DECAL, PINCH POINT DANGER	P10287	1
5	DECAL, SAW HEAD REST CAUTION	S12581	1
6	DECAL, LOG LIMIT STRIPE	S12051	2
7	DECAL, GS SAFETY CERTIFICATION, SMALL	P85072	1
8	DECAL, CE CERTIFIED SAWMILL, SMALL	P85070	1



## SECTION 9 LOG CLAMP

### 9.1 Log Clamp

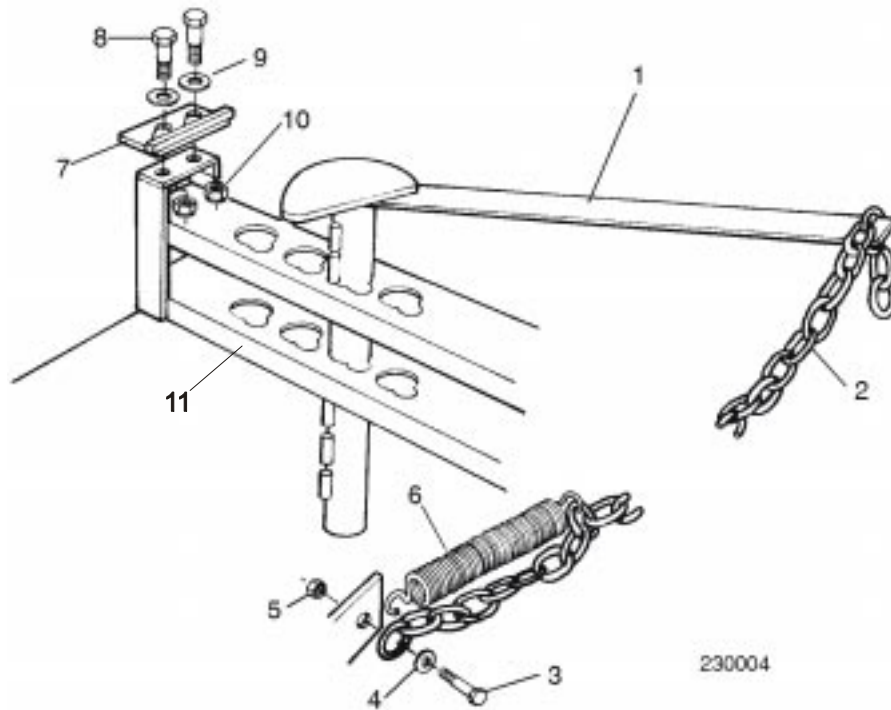

REF	DESCRIPTION (◆ Indicates Parts Available In Assemblies Only)	PART #	QTY.
1	CLAMP, LOG	W09412	1
2	CHAIN, LOG CLAMP	M04311	1
3	BOLT, M10X25-8.8-ZINC HEX HEAD	F81003-11	1
4	WASHER, 10.2 ZINC SPLIT LOCK	F81055-2	2
5	NUT, M10-8-B -ZINC HEX NYLON LOCK	F81033-1	1
6	SPRING, LOG CLAMP CHAIN	P09136	1
7	PLATE, LOG CLAMP STOP	086980-1	1
8	BOLT, M12 X 40-8.8 HEX HEAD	F81004-4	2
9	WASHER, 13 FLAT	F81056-1	2
10	NUT, M12-8 HEX NYLON LOCK	F81034-2	2
11	BRACKET, LOG CLAMP	086512	1

## 9.2 Manual Log Turner

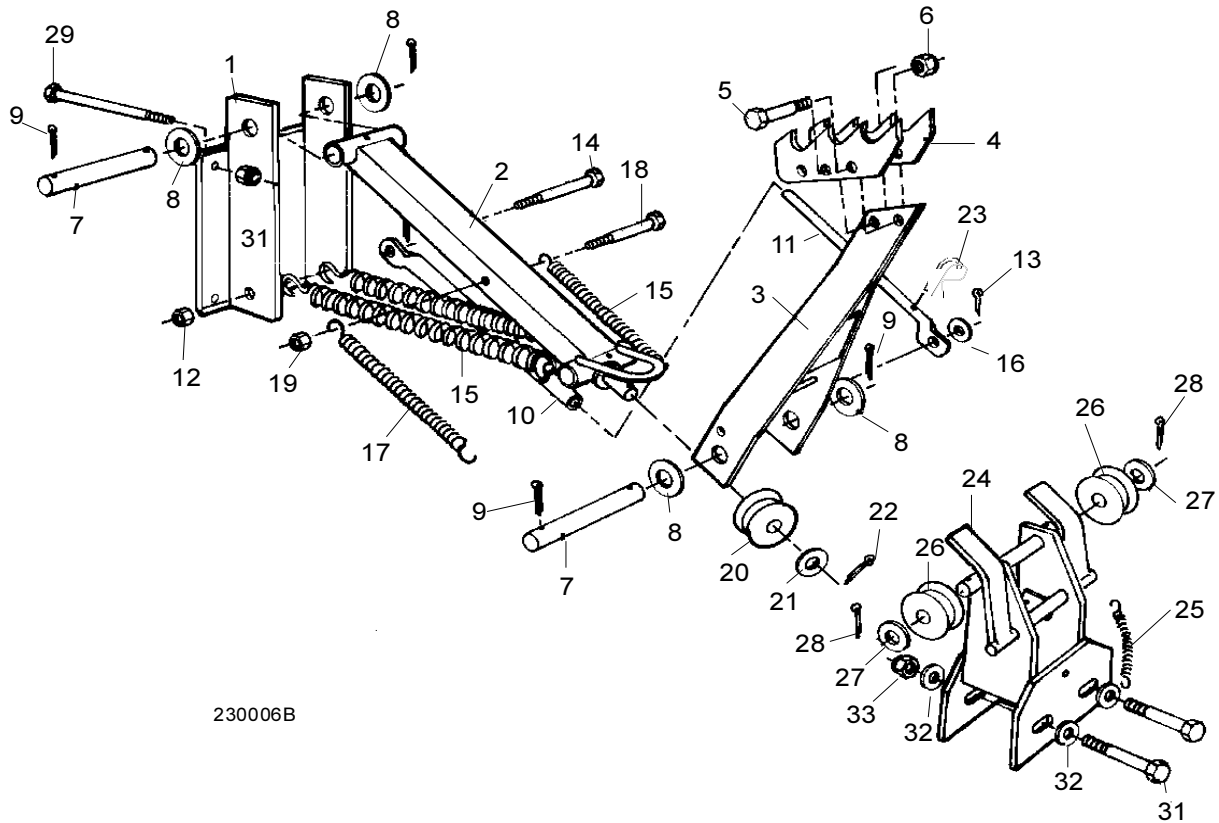

230006B

REF	DESCRIPTION (◆ Indicates Parts Available In Assemblies Only)	PART #	QTY.
	<b>MANUAL LOG TURNER OPTION</b>	LT-A	1
	Arm Assembly, Manual Log Turner	A09365	1
1	Bracket, Manual Log Turner Arm Mount	W09424	1
2	Arm, Lower Manual Turner	W09425	1
3	Arm, Upper Manual Turner	W09368-1	1
4	Claw, Log Turner	S09146	2
5	Bolt, M12 x 60-8.8 Hex Head	F81004-5	2
6	Nut, M12-8 Hex Nylon Lock	F81034-2	2
7	Pin, Manual Turner Arm Pivot	088082-1	2
8	Washer, 28 Flat	F81061-1	4
9	Pin, 3/16" x 1 1/2" Cotter	F05012-23	4
10	Tube, Manual Turner Stop	S09447	1
11	Rod, Manual Turner Stop	S09545	1
12	Nut, M12-8 Swaged Hex	F81034-2	1
13	Pin, 1/8" x 1" Cotter	F05012-1	1
14	Bolt, M12 x 125-8.8	F81004-33	1

<b>15</b>	Spring, Manual Turner Arm Upper	P09426	2	
<b>16</b>	Washer, 10.5 Flat	F81055-1	1	
<b>17</b>	Spring, Manual Turner Arm Lower	P09136	2	
<b>18</b>	Bolt, 3/8-16 x 4" Hex Head Grade 2	F05007-4	1	
<b>19</b>	Nut, 3/8-16 Hex Nylon Lock	F05010-10	1	
<b>20</b>	Pulley, Manual Turner Cable	S09394-W	1	
<b>21</b>	Washer, 3/4" Standard Flat	F81060-1	1	
<b>22</b>	Pin, 3/16" x 1 1/2" Cotter	F05012-23	1	
<b>23</b>	Pin, 3/16" Retaining	P05059	1	
	Pulley Assembly, Manual Turner Cable	A09371	1	
<b>24</b>	Bracket, Manual Turner Cable Pulley	W09428	1	◆
<b>25</b>	Spring, Manual Turner Cable Pulley	P04060	1	
<b>26</b>	Pulley, Manual Turner Cable	S09394-W	2	
<b>27</b>	Washer, 3/4" Standard Flat	F81060-1	2	
<b>28</b>	Pin, 3/16" x 1 1/2" Cotter	F05012-23	2	
<b>29</b>	Bolt, M10 x 125-8.8 Hex Head	F81003-18	4	
<b>30</b>	Nut, M10-8-B Hex Nylon Lock	F81033-1	4	
<b>31</b>	Bolt, M12 x 140-8.8 Hex Head	F81004-37	2	
<b>32</b>	Washer, 13 Flat	F81011-2	2	
<b>33</b>	Nut, M12-8 Hex Nylon Lock	F81034-2	2	

### 9.3 Manual Toe Board

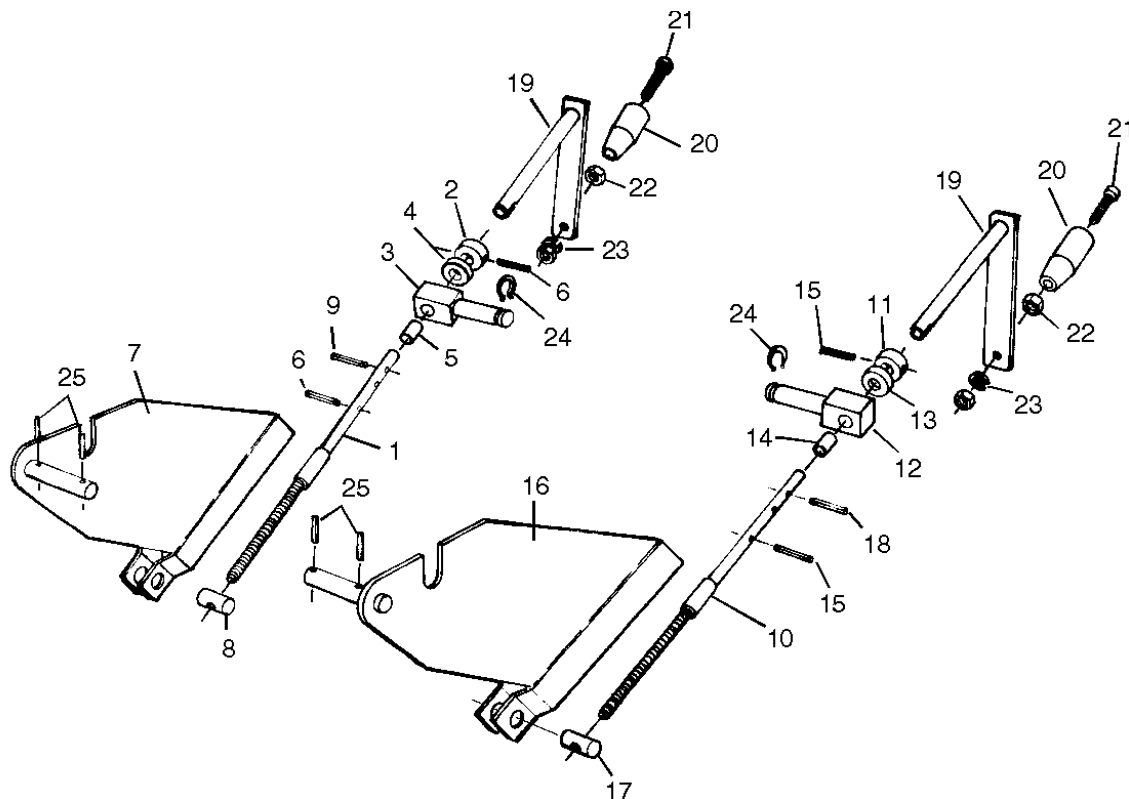

REF	DESCRIPTION (◆ Indicates Parts Available In Assemblies Only)	PART #	QTY.
	<b>TOE BOARD KIT, MANUAL</b>	A09306	1
	Shaft Assembly, Manual Toe Board	A09490	1
1	Shaft, Toe Board	W09289	1 ◆
2	Collar, 5/8" I.D.	S09561-W	1
3	Block, Toe Board Shaft Pivot	S09168	1
4	Bearing, 5/8" Thrust	P04214	1
5	Spacer, 5/8" I.D. x 3/4" O.D. x .945 Bronze	P09130	1
6	Pin, 3/16" x 1 1/4" Roll	F05012-16	3
7	Plate, Front Toe Board	W09491	1
8	Block, Manual Toe Board Threaded Trunnion	S04427	1
9	Pin, 3/16" x 1" Roll	F05012-11	1
	Toe Board, Rear Manual	A09307	1
	Shaft Assembly, Manual Toe Board	A09490	1
10	Shaft, Toe Board	W09289	1 ◆
11	Collar, 5/8" I.D.	S09561-W	1
12	Block, Toe Board Shaft Pivot	S09168	1
13	Bearing, 5/8" Thrust	P04214	1



<b>14</b>	Spacer, 5/8" I.D. x 3/4" O.D. x .945 Bronze	P09130	1	
<b>15</b>	Pin, 3/16" x 1 1/4" Roll	F05012-16	3	
<b>16</b>	Plate, Rear Toe Board	W09492	1	
<b>17</b>	Block, Manual Toe Board Threaded Trunnion	S04427	1	
<b>18</b>	Pin, 3/16" x 1" Roll	F05012-11	1	
	Handle Assembly, Manual Toe Board Crank	A09432	2	
<b>19</b>	Handle, Manual Toe Board Crank	W09431	1	◆
<b>20</b>	Handle, Crank	S08291-W	1	
<b>21</b>	Screw, 3/8-16 x 2 1/2" Socket Head Cap	F05007-24	1	
<b>22</b>	Nut, 3/8-16 Hex	F05010-1	2	
<b>23</b>	Washer, 3/8" Split Lock	F81055-2	1	
<b>24</b>	Ring, 7/8" O.D. Retaining	F04254-7	2	
<b>25</b>	Pin, 3/16" x 1" Roll	F05012-11	4	
	Instruction Sheet, Manual Toe Board Installation ('87 + Model Mills)	TB-237A	1	

### 9.4 Log Loading Ramps

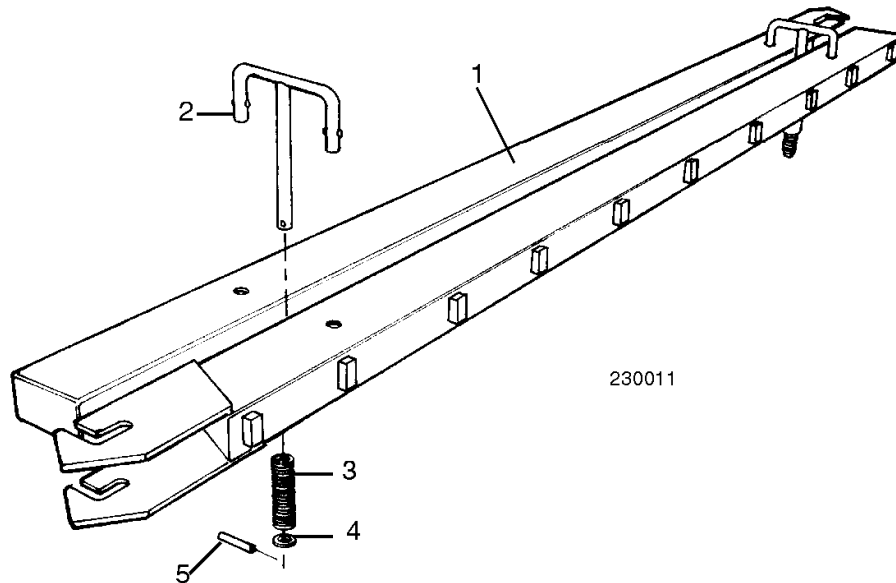

REF	DESCRIPTION (◆ Indicates Parts Available In Assemblies Only)	PART #	QTY.	
	<b>RAMP KIT, LOG LOADING WITH RETAINERS</b>	K09466	1	
1	Ramp, Log Loading	W09014	2	
	Retainer Kit, Log Ramp	K09810	2	
2	Retainer, Log Ramp	W09413	1	◆
3	Spring, Log Ram Retainer	P09335	1	
4	Washer, 5/8" I.D. x .100" Thick Nylon	F05011-19	1	
5	Pin, 3/16" x 1" Roll	F05012-11	1	

## SECTION 10 MANUAL FEED

### 10.1 Manual Feed Rope Assembly

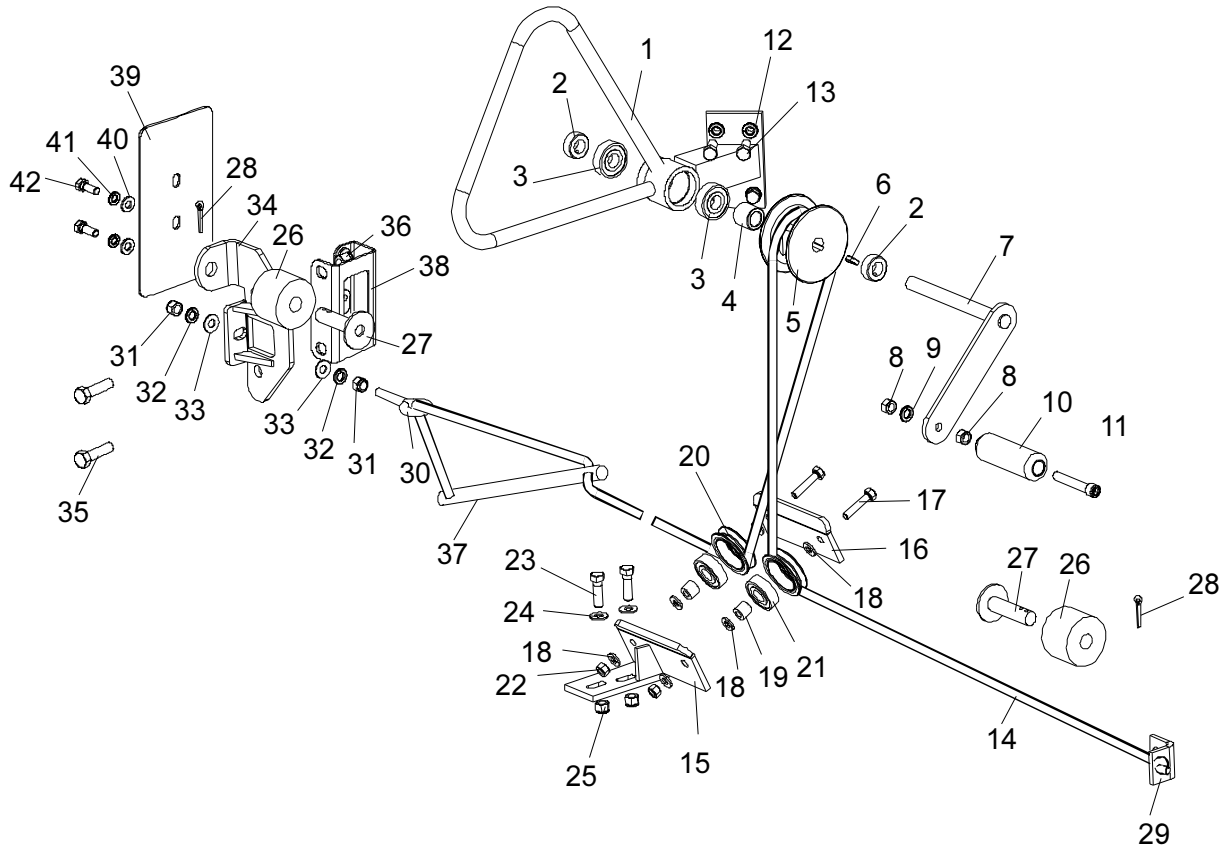

250015B

REF	DESCRIPTION (◆ Indicates Parts Available In Assemblies Only)	PART #	QTY.	
	<b>CRANK ASSEMBLY, MANUAL FEED ROPE</b>	086347	1	
1	Housing, Manual Feed Crank	W12444-1	1	◆
2	Collar, 5/8" I.D. With Set Screw	P05035	2	
3	Bearing, 5/8" 6203-2NSL	P06030-1	2	
4	Spacer, 1"	S12479-W	1	
5	Pulley, LT25 Manual Feed Crank	S12457	1	
6	Key, #606 Woodruff	P04101-1	1	
	Handle Assembly, LT25 Manual Feed Crank	A12336	1	
7	Crank, LT25 Manual Feed	086342-1	1	◆

# 10

## Manual Feed Manual Feed Rope Assembly

8	Nut, 3/8-16 Hex	F05010-1	2	
9	Washer, 10.2 Split Lock	F81055-2	1	
10	Handle, Crank	086338	1	
11	Bolt, 3/8-16 x 2 1/2" Socket Head	F05007-24	1	
12	<b>WASHER, 10.2 SPLIT LOCK</b>	F81055-2	4	
13	<b>BOLT, 3/8-16 X 1" HEX HEAD GRADE 2</b>	F05007-7	4	
14	<b>ROPE, 5/16" DIA. SOLID BRAIDED POLYESTER (LT25)</b>	R02080	26 Ft.	
	<b>ROPE, 5/16" DIA. SOLID BRAIDED POLYESTER (LT25L)</b>	R02080	30.3 Ft.	
	<b>ROLLER ASSEMBLY, FEED ROPE GUIDE</b>	A12458	1	
15	Bracket, Rope Guide Roller Mount	W12460-1	1	◆
16	Plate, Rope Guide Roller Mount	S12464-1	1	◆
17	Bolt, 5/16-18 x 1 1/2" Hex Head Full Thread	F05006-2	2	
18	Washer, 8.4SAE Flat	F81054-1	6	
19	Sleeve, Bearing	S05142	2	◆
	Roller Assembly, Rope Guide With Bearing	A09059	2	
20	Roller, Rope Guide V-Groove	S07989-W	1	◆
21	Bearing, 5/8" I.D. 6203-2NSL	P06030-1	1	
22	Nut, 5/16-18 Hex Lock	F05010-6	2	
23	<b>BOLT, 3/8-16 X 1 1/4" HEX HEAD GRADE 2</b>	F05007-2	2	
24	<b>WASHER, 10.5 SAE FLAT</b>	F81055-1	2	
25	<b>NUT, 3/8-16 HEX NYLON LOCK</b>	F05010-10	2	
	<b>STOP KIT, RUBBER CARRIAGE</b>	K09630	2	
26	Stop, Rubber Carriage	P12165	1	◆
27	Pin, Rubber Carriage Stop	086182-1	1	
28	Pin, 3/16" x 1" Cotter	F05012-21	1	
29	<b>BRACKET, FEED ROPE MOUNTING</b>	S12466	1	
30	<b>BOLT, 3/8-16 X 2" EYE 5/8" I.D.</b>	F05007-30	1	
31	<b>NUT, 3/8-16 HEX</b>	F05010-10	2	
32	<b>WASHER, 10.2 SPLIT LOCK</b>	F81055-2	2	
33	<b>WASHER, 10.5 SAE FLAT</b>	F81055-1	2	
34	<b>BRACKET, REAR FEED ROPE TENSIONER</b>	W11822	1	
35	<b>BOLT, M12 X 40-8.8 HEX HEAD GRADE 5</b>	F81004-4	2	
36	<b>NUT, M12-8 NYLON HEX</b>	F81034-2	2	
37	<b>ROD, FEED ROPE TENSIONER</b>	S12468	1	
38	<b>BRACKET WELDMENT, REAR TUBE COVER MOUNT</b>	087105-1	1	
39	<b>COVER, MAIN TUBE REAR</b>	015023	1	
40	<b>WASHER, 8.4 SAE FLAT</b>	F81054-1	2	
41	<b>WASHER, 8.2 SPLIT LOCK</b>	F81054-4	2	
42	<b>BOLT, 5/16-18 X 1" HEX HEAD</b>	F05006-1	2	