

Debarker Option

Safety, Installation, Operation, Maintenance & Parts Manual

MKII for LT70 Sawmills

rev. D.2



Safety is our #1 concern! Read and understand all safety information and instructions before operating, setting up or maintaining this machine.

Form #553

Table of Contents

Section-Page

SECTION 1	SAFETY & GENERAL INFORMATION	1-1
1.1	Installation and Maintenance.....	1-1
1.2	Operation and Towing.....	1-2
SECTION 2	DEBARKER INSTALLATION	2-1
2.1	Debarker Frame Mounting Holes.....	2-2
2.2	Debarker Installation.....	2-2
2.3	Wiring Instructions.....	2-7
2.4	Control Component Installation (Non-Remote Mills).....	2-13
2.5	Control Component Installation (Remote Mills).....	2-19
2.6	Alignment.....	2-25
SECTION 3	OPERATION AND MAINTENANCE	3-1
3.1	Locking Pin Operation.....	3-1
3.2	Operation.....	3-2
3.3	Maintenance.....	3-4
3.4	Troubleshooting.....	3-6
SECTION 4	DEBARKER PARTS	4-1
4.1	How To Use The Parts List.....	4-1
4.2	Sample Assembly.....	4-1
4.3	Locking Pin Assembly.....	4-2
4.4	Frame Assembly.....	4-4
4.5	In/Out Motor Drive Assembly.....	4-5
4.6	Blade Motor Assembly.....	4-7
4.7	Blade Housing Assembly.....	4-9
4.8	Debarker Control Assembly.....	4-11
4.9	Spring Rod Assembly.....	4-12
4.10	Wider Debarker Assembly.....	4-13
4.11	AC Debarker Blade Drive.....	4-16
4.12	DC Debarker Blade Drive.....	4-18

SECTION 1 SAFETY & GENERAL INFORMATION



This symbol calls your attention to instructions concerning your personal safety. Be sure to observe and follow these instructions. This symbol accompanies a signal word. The word **DANGER** indicates an imminently hazardous situation which, if not avoided, will result in death or serious injury. **WARNING** suggests a potentially hazardous situation which, if not avoided, could result in death or serious injury. **CAUTION** refers to potentially hazardous situations which, if not avoided, may result in minor or moderate injury to persons or equipment. Read all safety instructions before operating this equipment and observe all safety warnings!

1.1 Installation and Maintenance



DANGER! On electric mills, hazardous voltage inside the disconnect box, starter box, and at the electric motor can cause shock, burns, or death. Disconnect and lock out power supply before performing debarker installation! Follow all applicable electrical codes.

DANGER! Make sure all electrical installation, service and/or maintenance work is performed by a qualified electrician and is in accordance with applicable electrical codes. Failure to do so will result in serious injury or death.

DANGER! Before performing any service to this equipment, turn the key to the OFF position, remove the key, and disconnect the sawmill battery ground terminal. Failure to do so will result in serious injury or death.



WARNING! Before replacing the debarker blade, move the sawmill blade guide arm in front of the sawmill blade to cover the blade teeth. Failure to do so may result in serious injury or death.

1.2 Operation and Towing



DANGER! Make sure all guards and covers are in place and secured before operating the debarker option. Failure to do so may result in serious injury.

DANGER! Keep all persons out of the path of moving equipment when operating the debarker. Failure to do so will result in serious injury.

DANGER! Always remove the key from the control panel before preparing the debarker for towing. Failure to do so may result in serious injury.



WARNING! Debarker is ON when warning bell sounds. DO NOT disconnect the warning bell. Doing so may result in serious injury.

WARNING! If the debarker continues to run with the key switch in the OFF position, remove the negative battery terminal from the battery post.

DO NOT continue to operate the mill if the main key switch does not control debarker operation. Doing so could result in serious injury. Call Wood-Mizer customer service for more information.

SECTION 2 DEBARKER INSTALLATION



DANGER! On electric mills, hazardous voltage inside the disconnect box, starter box, and at the electric motor can cause shock, burns, or death. Disconnect and lock out power supply before performing debarker installation! Follow all applicable electrical codes.

DANGER! Before performing any service to this equipment, turn the key to the OFF (0) position, remove the key, and disconnect the sawmill battery ground terminal. Failure to do so will result in serious injury or death.



CAUTION! Due to various design changes and past retrofits and options, you should very carefully look your mill over to determine Debarker compatibility before beginning Debarker installation.

2.1 Debarker Frame Mounting Holes

IMPORTANT! Sawmills are equipped with pre-drilled Debarker mounting holes. **Verify hole locations before beginning Debarker installation. Proper hole location is imperative for safe and effective Debarker operation.**

2.2 Debarker Installation

NOTE: You would not use all components of the debarker bag assembly during installation. Excess hardware is included to cover all possible mill variations and needs.

1. Remove the four pre-installed bolts and nuts from the debarker frame mounting blocks.
2. Assemble the debarker to the sawmill saw head. Align the mounting block holes and the holes in the saw head. Insert the bolts from the back of the saw head, through the debarker mounting block holes. Use the lock nuts to secure in place. Tighten the mounting bolts to 20 ft.-lbs. torque. Do not tighten the set screws in the mounting blocks until debarker alignment has been performed.

NOTE: When installing, make sure the blade guide motor wire harness is routed between the saw head and the pivot arm.

See Figure 2-1.

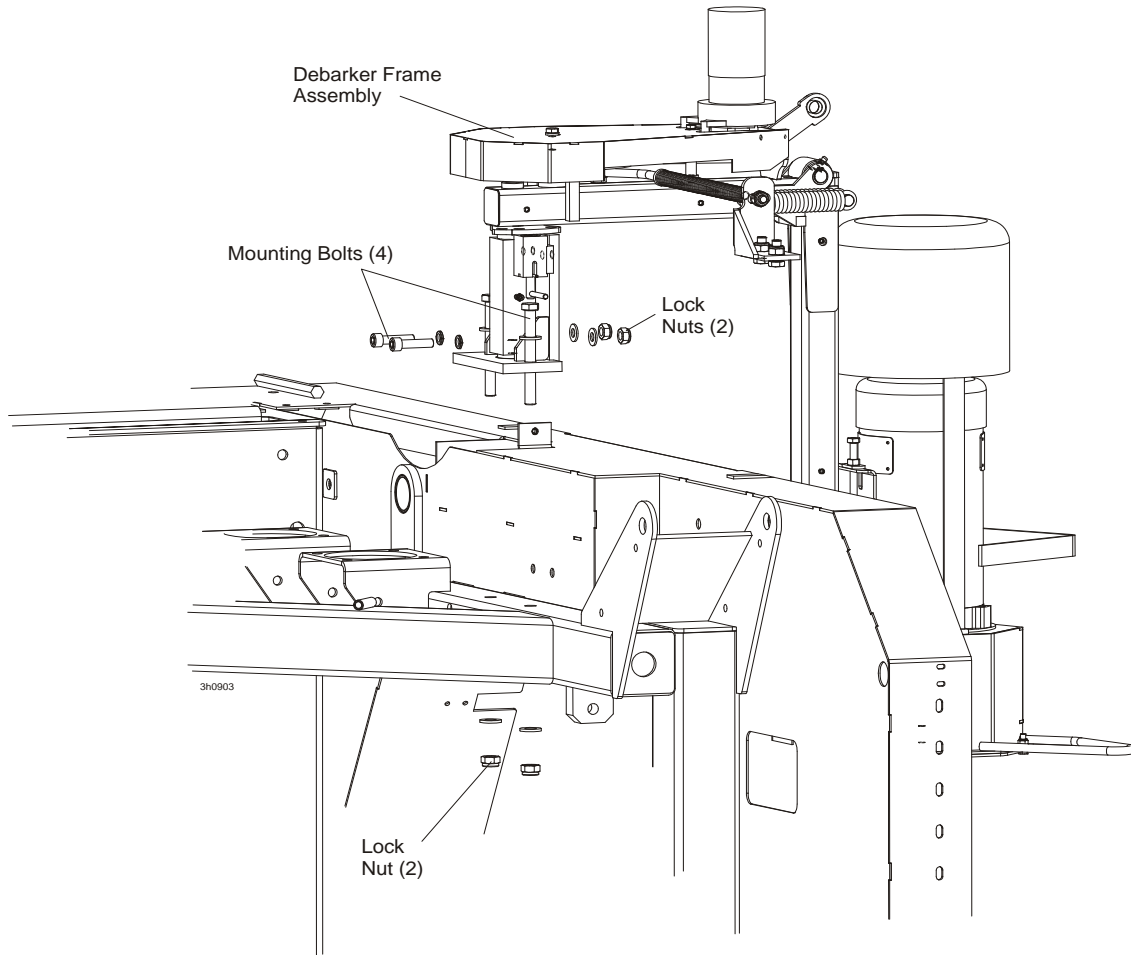

FIG. 2-1

2 Debarker Installation

Debarker Installation

3. Assemble the debarker cutting head to the mount plate on the frame. Use the four provided M8x35 -8.8" bolts, 8,4 split lock washers and M8-8 nuts to mount the cutting head to the debarker frame. Use the lower set of four holes in the head mounting plate. The upper set of holes are provided in the event the cutting head needs to be adjusted further down than the slotted motor mount holes will allow.

See Figure 2-2.

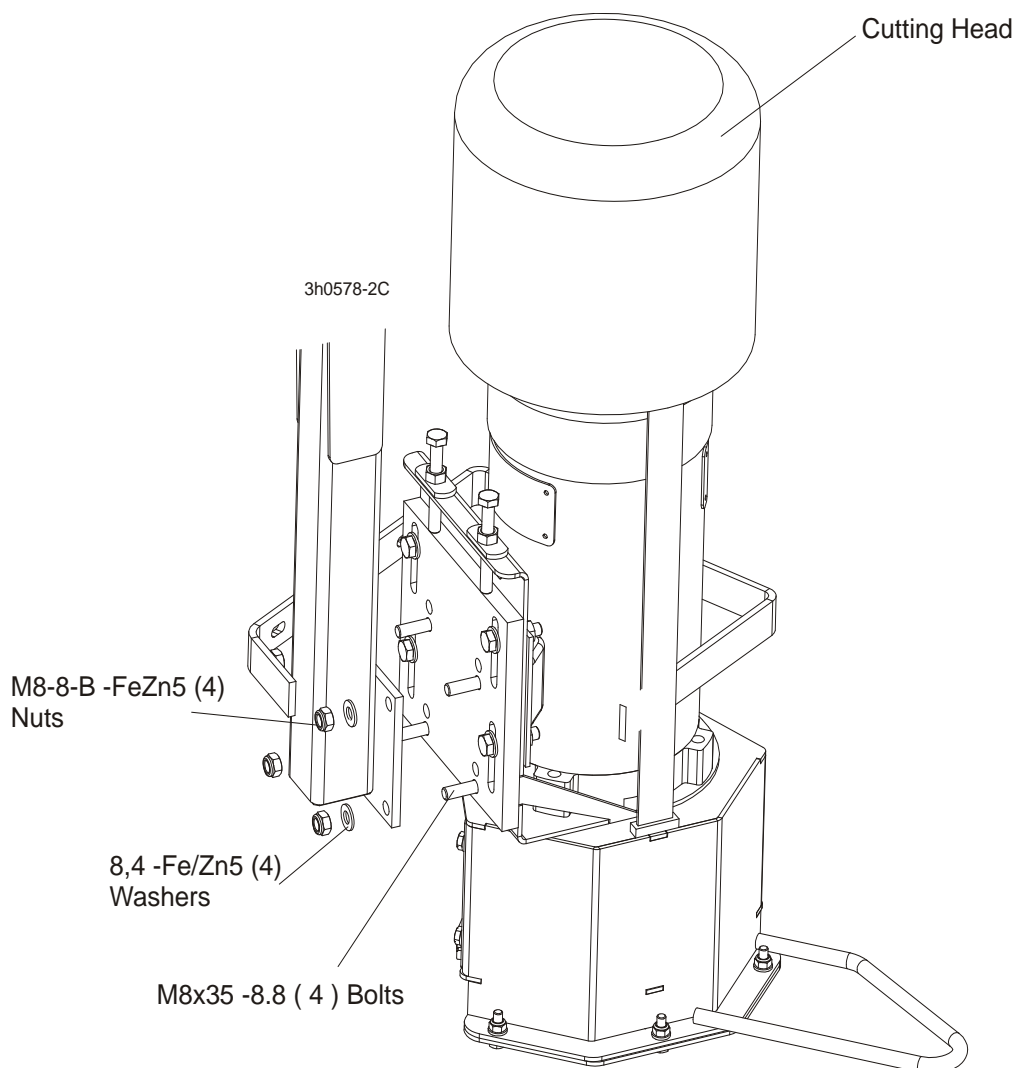

FIG. 2-2

4. Install the spring arm assembly to the debarker in/out pulley using the M10x45-8.8-Fe/Zn5 hex head bolt, two flat washers, and two lock nuts provided.
5. Remove the idle-side blade housing cover. Align the two holes in the spring arm bracket with the two holes in the top of the saw head blade housing. Use the provided M10x25-8.8 hex head bolts and M10-8-B nylon lock nuts to secure the spring arm bracket saw head. Replace the blade housing cover. Close the middle blade housing cover.

See Figure 2-3.

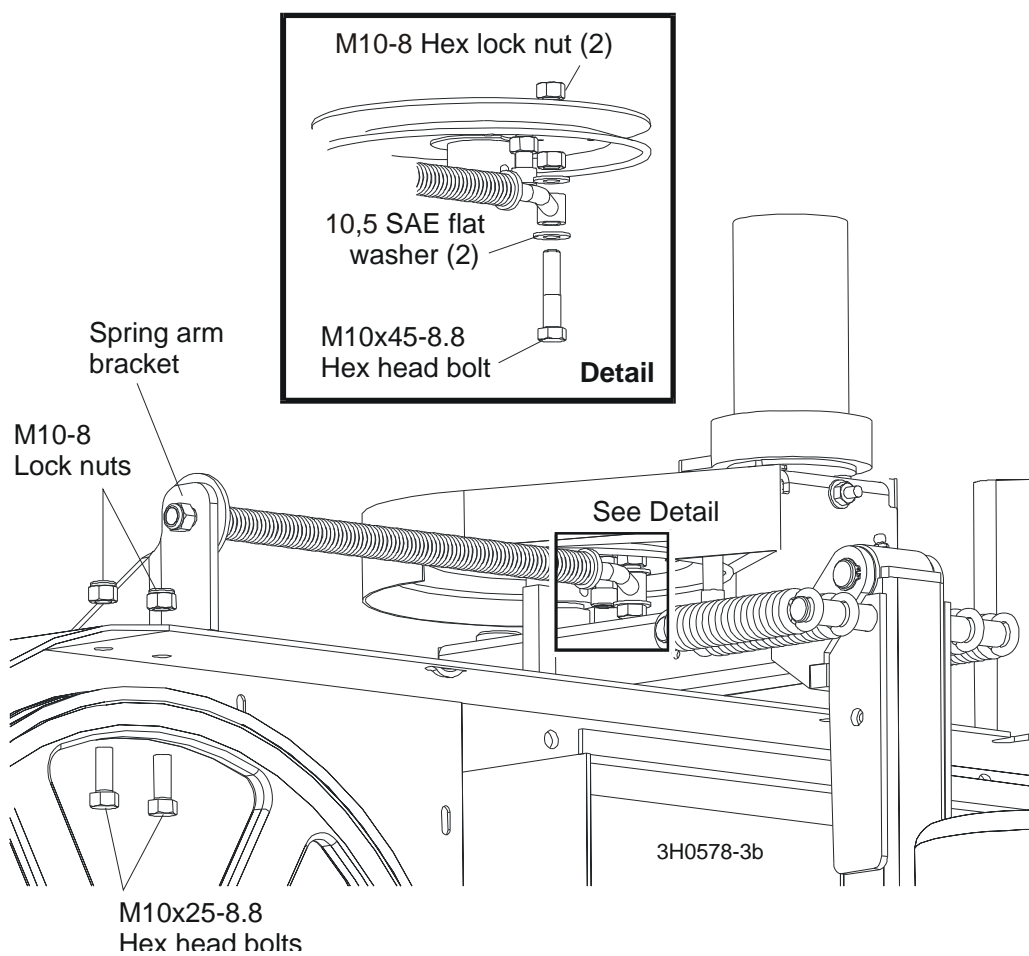

FIG. 2-3

2 Debarker Installation

Debarker Installation

6. Install the blade guard bracket and flexible debris guard to the debarker head with two 6,4 flat washers, lock washers, and M6x16 8.8 hex head bolts. Be sure the bottom of the debris guard is even with the bottom of the debarker blade.

See Figure 2-4.

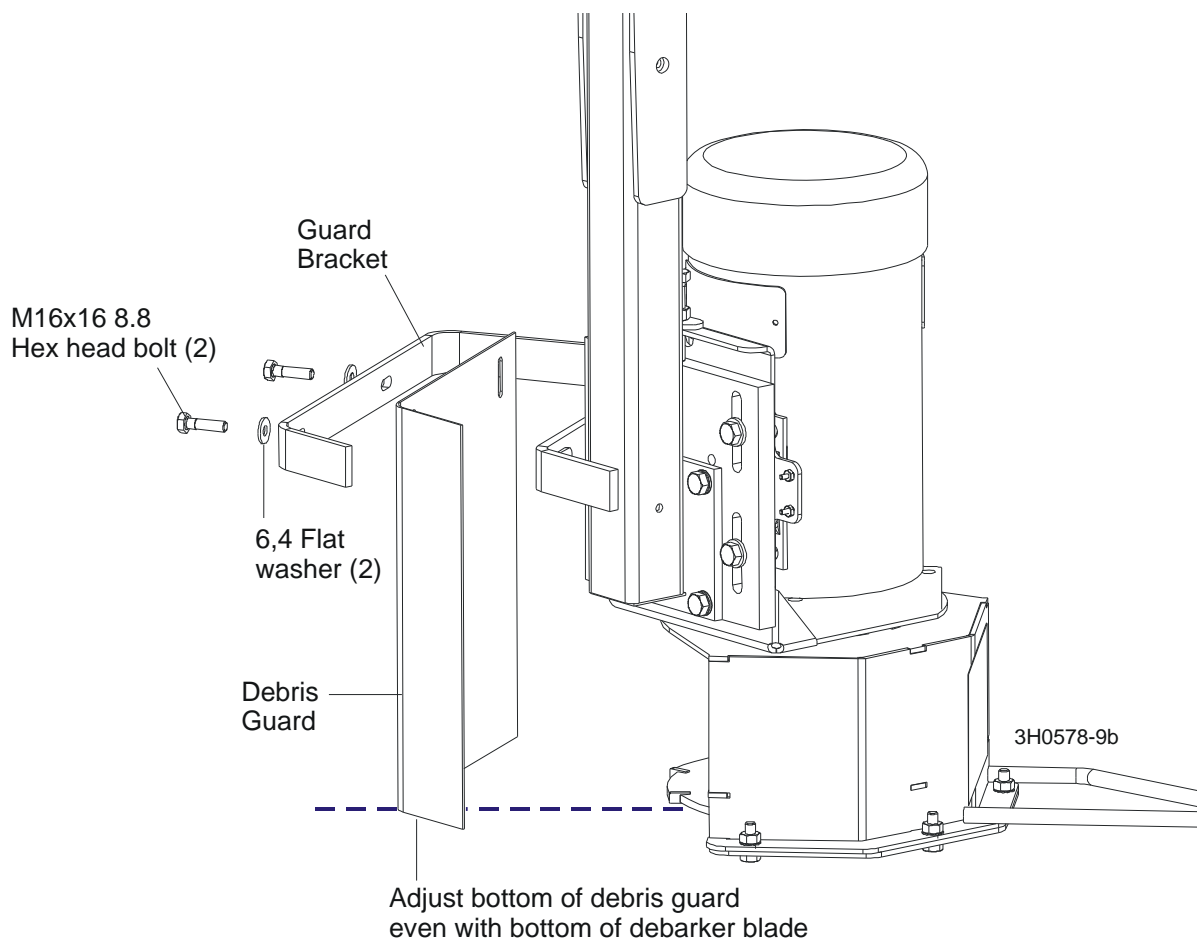

FIG. 2-4

2.3 Wiring Instructions



DANGER! On electric mills, hazardous voltage inside the disconnect box, starter box, and at the electric motor can cause shock, burns, or death. Disconnect and lock out power! Follow all applicable electrical codes.

DANGER! Before performing any service to this equipment, turn the key to the OFF (0) position, remove the key, and disconnect the sawmill battery ground terminal. Failure to do so will result in serious injury or death.



IMPORTANT! Avoid pinch and pivot points, unnecessary wire bending and open spaces where the wire could get caught by a log, etc. If you have any questions, call Wood-Mizer customer service.

1. 1997 and newer model sawmills are pre-wired for the debarker option. On sawmills built before 7/97, the debarker wires are stored inside the drive pulley housing. On sawmills built after 7/97, the debarker wires are pre-routed and stored under a guard which is removed before debarker installation ([See Section 2.2](#)). Skip to Step 4 if your sawmill debarker wiring is pre-routed.
2. Remove the drive pulley housing and locate the wires (#21-24). The fifth wire (#25) is for the optional laser sight and should remain in place.
3. Remove the lower drive belt cover. Slide the long piece of expandable conduit over all four wires. Route the wire/conduit along the existing wiring under the sawmill engine/motor mount plate. Secure the wires in the existing clamps or use the provided wire ties to secure the new harness to the existing harnesses.
4. Route the harness between the debarker mount and saw head as shown. Slide the harness through one of the supplied harness clamps until about 75 mm (3") of the harness protrudes past the clamp. Install the clamp at location #1 on the debarker frame with a 1/4" flat washer and 1/4-20 x 1/2" hex head bolt.

2 Debarker Installation

Wiring Instructions

See Figure 2-5.

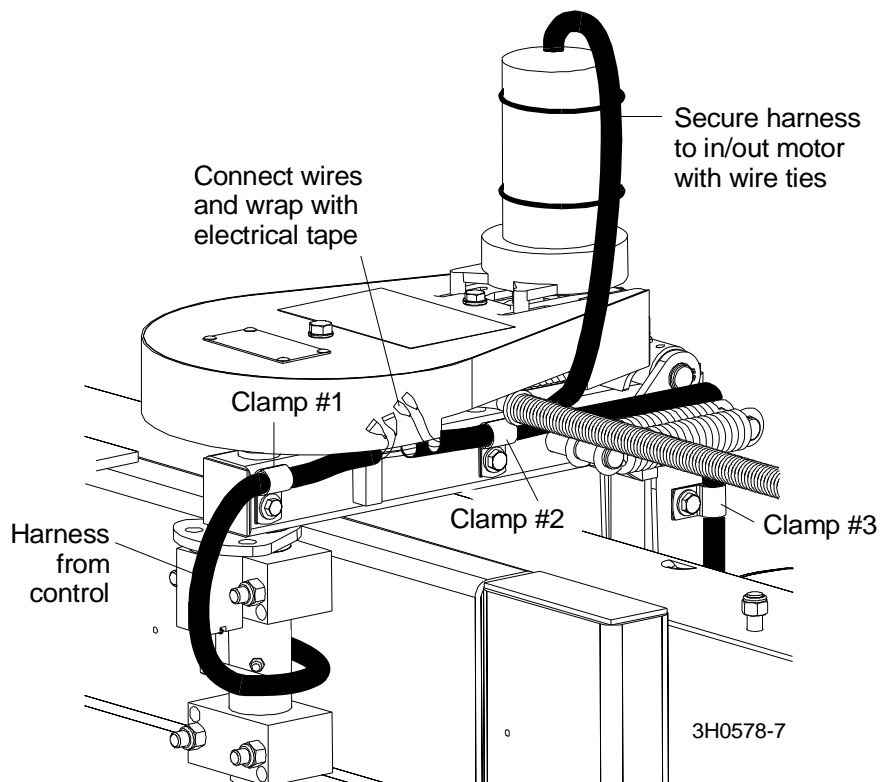

FIG. 2-5

5. Route the two long wires through the remaining long section of conduit. Slide the harness through two harness clamps and secure at #2 and #3 locations on the debarker frame with 1/4" flat washers and 1/4-20 x 7/8" hex head bolts. Be sure to leave enough slack in the harness to allow the debarker its full range of movement and also to prevent undue wire stress from sharply bent wires.
6. Install the shortest piece of conduit over the red and black debarker in/out motor wires.
7. Route the cable underneath the spring arm, through harness clamp #2, to the control cable.
8. Use two of the provided wire ties to secure the harness to the side of the drive motor.
9. Strip the end of the black drive motor wire and install a provided 1/4" male quick connect terminal.

Cut the red drive motor wire so it is 25 mm (1") shorter than the black drive motor wire, strip the end, and install a provided 1/4" male quick connect terminal. This will allow the wires to be neatly bundled together and wrapped later.

10. Connect the red drive motor wire to the red control harness wire. Connect the black drive motor wire to the black control harness wire. Wrap the wire connections with electrical tape.

2

Debarker Installation

Wiring Instructions

11. Slide the blade motor harness through a harness clamp and secure at location #4 on the debarker frame with a 1/4" flat washer and 1/4-20 x 7/8" hex head bolt. Route the harness and wires from the warning bell to the terminal posts on the blade motor.

See Figure 2-6.

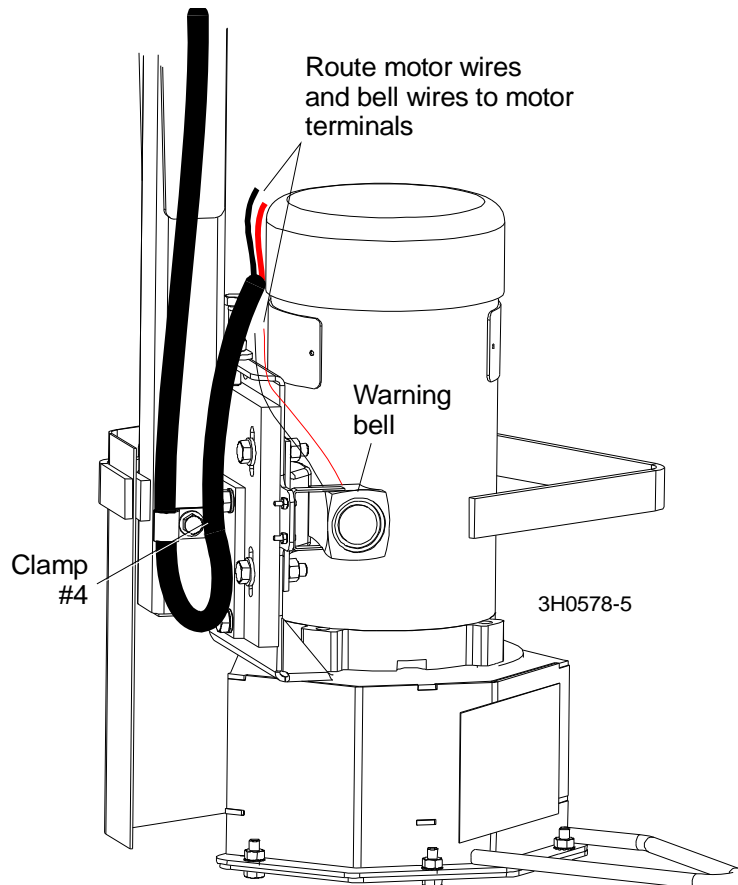

FIG. 2-6

12. Secure the warning bell wires to the motor harness with a wire tie approximately 75 mm (3") from the motor terminals as shown.

See Figure 2-7.

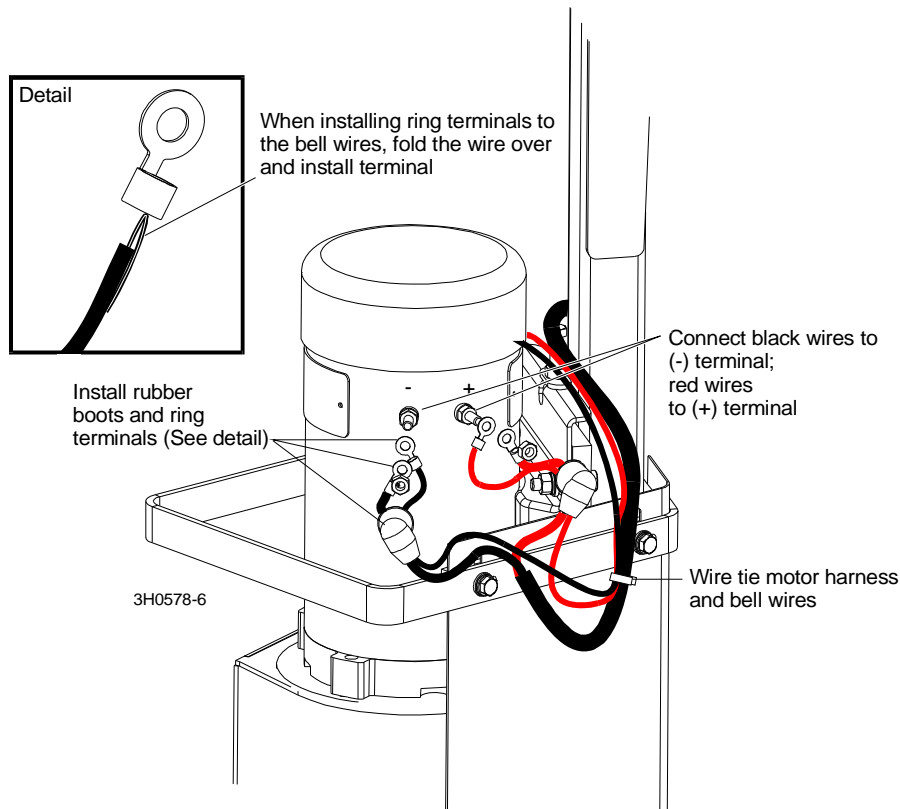

FIG. 2-7

13. Remove the top nuts from each of the motor terminals. The harness conduit and wires will be longer than necessary (to allow for differences in routing). Cut excess length.
14. Route the black motor wire from the harness and the black wire from the warning bell through one of the provided rubber boots. Strip the end of the black motor wire and install a 1/4" 8 gauge ring terminal. Strip the end of the black warning bell wire and install a 1/4" 14-16 gauge ring terminal. To install the 14-16 gauge ring terminal, fold the stripped end of the wire over the insulation, install the ring terminal and crimp in place.
15. Connect the black motor and bell wires to the negative (-) motor terminal. Replace the terminal nut to secure the wires.



IMPORTANT! Make sure that the ring terminals do not touch the motor body.

2

Debarker Installation

Wiring Instructions

16. Route the red motor wire and the red wire from the warning bell through one of the provided rubber boots. Strip the end of the red motor wire and install a 1/4" 8 gauge ring terminal. Strip the end of the red warning bell wire and install a 1/4" 14-16 gauge ring terminal. To install the 14-16 gauge ring terminal, fold the stripped end of the wire over the insulation, install the ring terminal and crimp in place.
17. Connect the red motor and bell wires to the positive (+) motor terminal. Replace the terminal nut to secure the wires.



IMPORTANT! Make sure that the ring terminals do not touch the motor body.

18. Slide the rubber boots over the motor terminal posts to protect the connections.
19. Replace all removed covers and guards.

2.4 Control Component Installation (Non-Remote Mills)



DANGER! On electric mills, hazardous voltage inside the disconnect box, starter box, and at the electric motor can cause shock, burns, or death. Disconnect and lock out power! Follow all applicable electrical codes.

DANGER! Before performing any service to this equipment, turn the key to the OFF (0) position, remove the key, and disconnect the sawmill battery ground terminal. Failure to do so will result in serious injury or death.

[See Section 2.5](#) if assembling the Debarker option to a sawmill equipped with the remote operation option. [See Section 4.4](#) or [Section 4.5](#) for a complete wiring diagram to aid in installation.

1. Remove the side, front and rear panels (leave wire connections) from the control box.
2. Install the debarker solenoid on the two weld studs. Put the solenoid diode assembly ring terminal over one of the weld studs. Use the two 1/4-20 keps nuts provided to secure in place.

2

Debarker Installation

Control Component Installation (Non-Remote Mills)

See Figure 2-8.

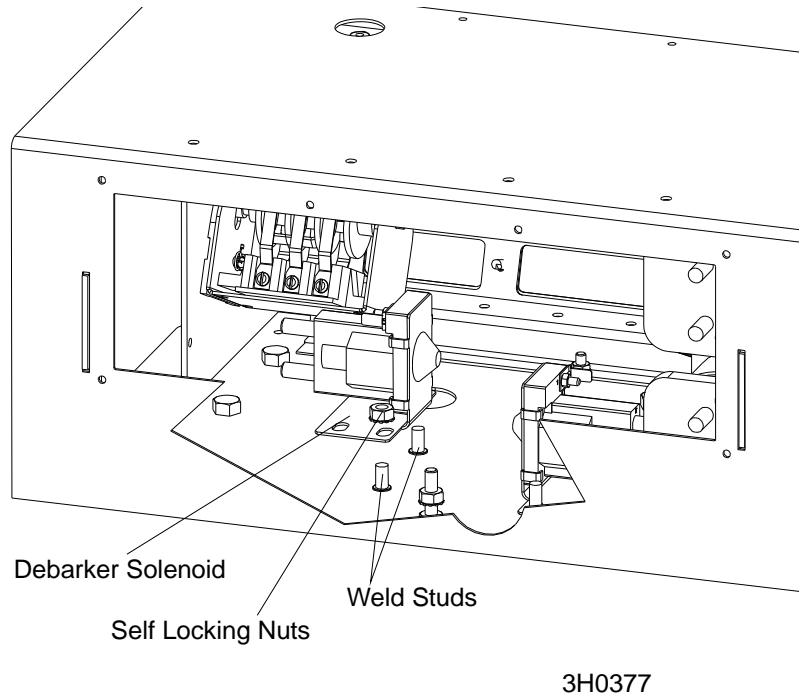

FIG. 2-8

3. Remove the two small bolts and nuts and the one large bolt and nut from the back of the control box.
4. Locate the bundle of wires on the floor of the sawmill control box. Make sure the large black #24 wire is connected to the rear ground stud. Connect the large red #23 wire to the empty terminal on the provided 70 amp breaker. Do not overtighten this connection. Overtightening could cause component breakage.
5. Install the 70 amp breaker and rubber boot to the large hole on the back of the control box. Be sure the breaker terminals do not touch any other components or wires inside the control box.

6. Install the provided 15 amp breaker to the two small holes in the back of the control box (reset tab up). Use the existing screws and nuts (removed earlier) to secure in place.

See Figure 2-9.

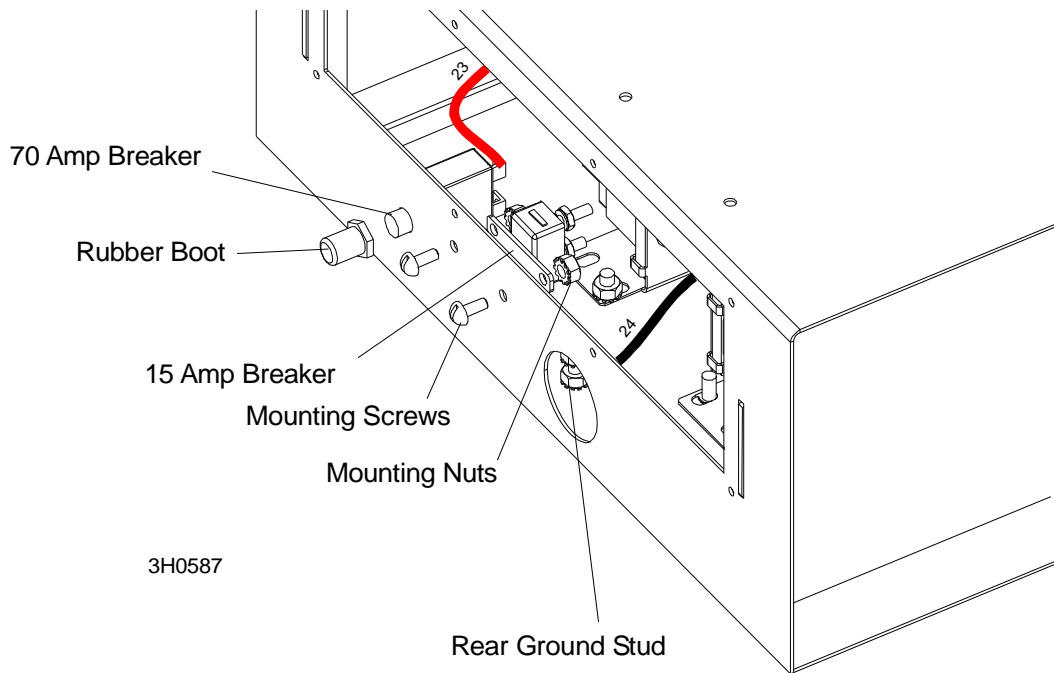

FIG. 2-9

2 Debarker Installation

Control Component Installation (Non-Remote Mills)

7. Using the back side of the front panel for a guideline, cut out holes in the front panel lexan decal for the debarker switches. Install the provided toggle switches, 1/16" nylon washers, and rubber boots in place as shown.

See Figure 2-10.

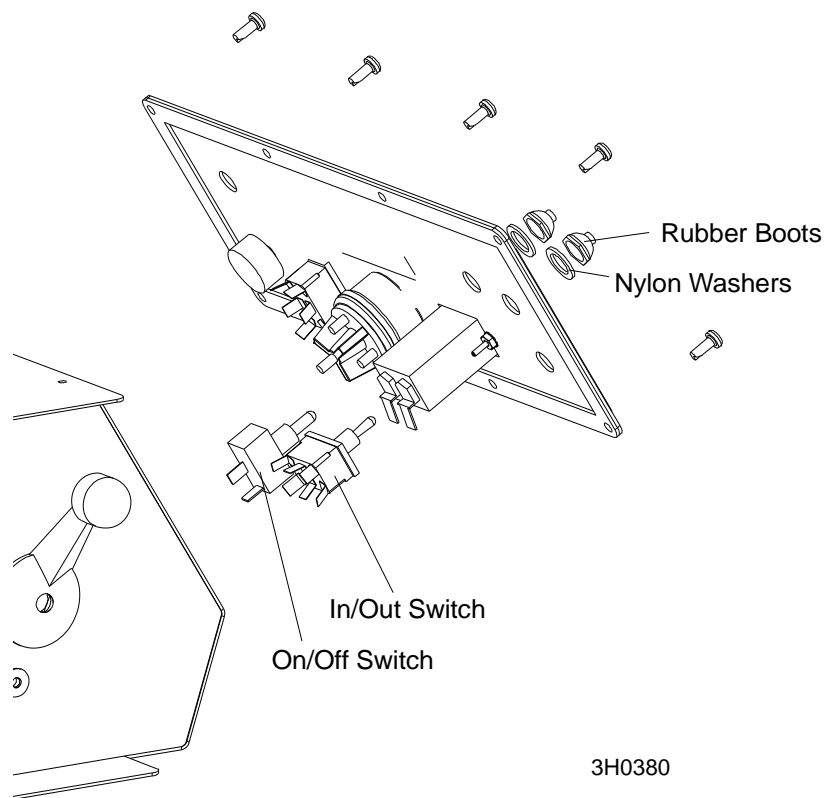
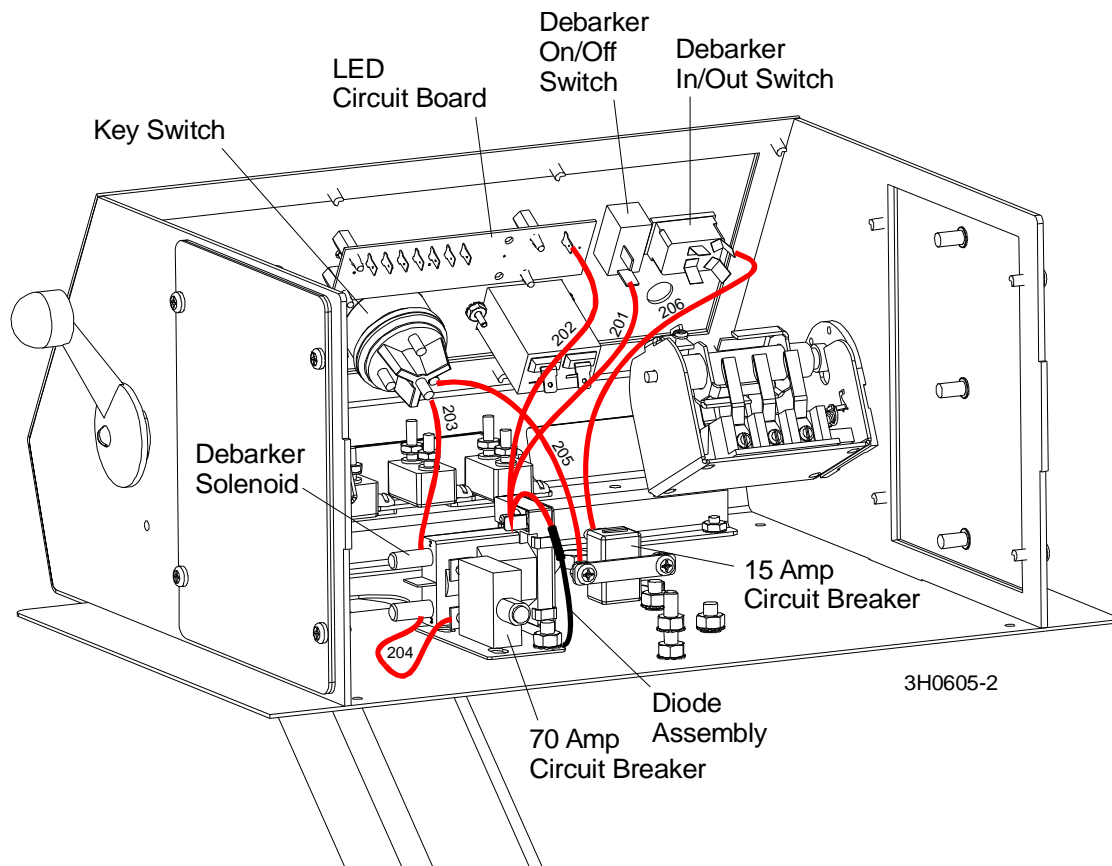

FIG. 2-10

8. Connect the red #205 wire from the 15 amp breaker to the ACC post on the key switch.
9. Make sure the red #206 wire from the 15 amp breaker to the debarker in/out switch is connected.
10. Connect the red #202 wire from the debarker solenoid to the DBKR terminal on the LED board.
11. Make sure the red #201 wire from the small terminal on the debarker solenoid to the debarker on/off switch is connected.
12. Connect the red #203 wire from debarker solenoid to the BAT post of the key switch.
13. Make sure the red #204 wire from the bottom debarker solenoid terminal to the 70 Amp breaker is connected.

See Figure 2-11. Box housing removed for clarity. Only wires referred to above are shown. Standard control box shown, Super model control differs slightly.

**FIG. 2-11**

2

Debarker Installation

Control Component Installation (Non-Remote Mills)

14. Connect the red #200 wire from the debarker on/off switch to terminal #2 of the power feed drum switch.
15. Connect the black #207 wire from the debarker in/out switch to the rear ground stud.
16. Locate the bundle of wires on the floor of the sawmill control box. Make sure the debarker in/out switch is oriented horizontally as shown.
17. Connect the small red #21 wire to the debarker in/out switch bottom left terminal.
18. Connect the small black #22 wire to the debarker in/out switch top middle terminal.

See Figure 2-12. Box housing removed for clarity. Only wires referred to above are shown. Standard control box shown, Super model control differs slightly.

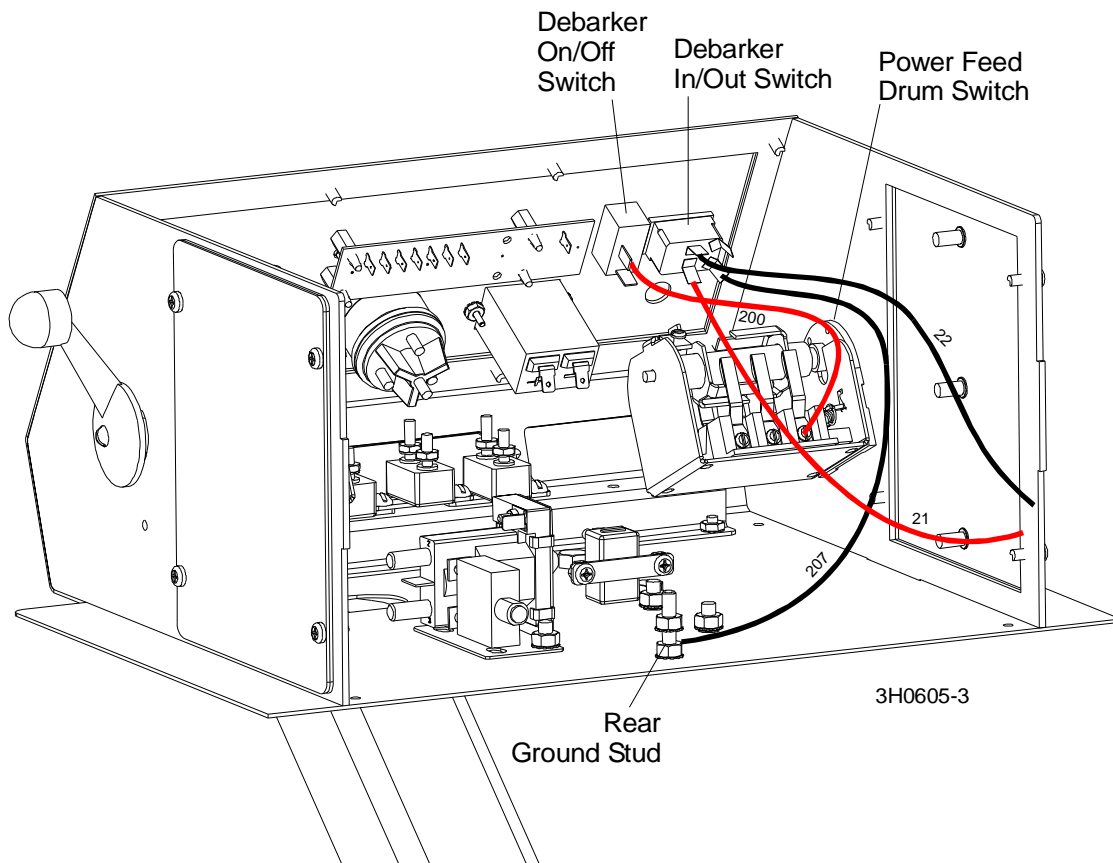

FIG. 2-12

19. Reinstall the front and rear panels, side panel, and control box top cover to the control box.

2.5 Control Component Installation (Remote Mills)



DANGER! On electric mills, hazardous voltage inside the disconnect box, starter box, and at the electric motor can cause shock, burns, or death. Disconnect and lock out power! Follow all applicable electrical codes.

DANGER! Before performing any service to this equipment, turn the key to the OFF (0) position, remove the key, and disconnect the sawmill battery ground terminal. Failure to do so will result in serious injury or death.

[See Section 2.4](#) if assembling the Debarker option to a sawmill not equipped with the remote operation option. [See Section 4.6](#) for a complete wiring diagram to aid in installation.

Remote Power Box Component Installation

See Figure 2-13.

1. Open the remote power junction box door.
2. Install the debarker solenoid next to the existing solenoid with the two bolts and nuts provided in the bottom of the box. Place the diode ring terminal over one of the solenoid mounting bolts before securing with the nuts.
3. Locate the large red #23 wire in the remote power box and connect it to the empty terminal on the provided 70 Amp breaker. Do not overtighten this connection. Overtightening could cause component breakage.
4. Remove the bolt and nut from the hole in the side of the remote power box and install the 70 Amp breaker and rubber boot to the hole. Be sure the breaker terminals do not touch any other components or wires inside the control box.
5. Make sure the large black #24 wire is connected to the side ground stud.
6. Locate the small red wire from connector P2 terminal #18. Connect it to the small, top terminal on the debarker solenoid.
7. Connect large red #203 wire from the large bottom terminal of the debarker solenoid to the large bottom terminal of the accessory solenoid.

2 Debarker Installation

Control Component Installation (Remote Mills)

Only wires referred to above are shown.

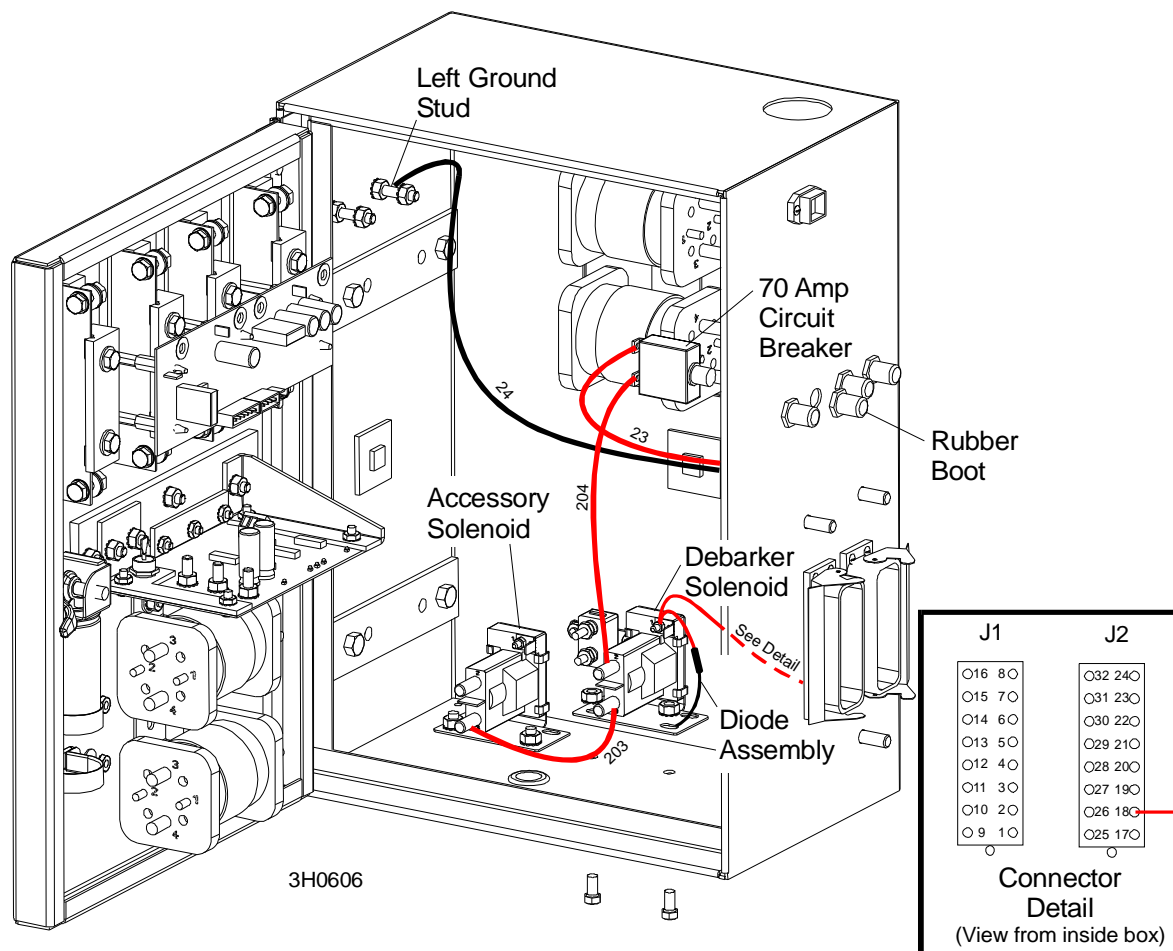

FIG. 2-13

- Close the remote power box door. Engage the door latch and tighten with a hex key to properly seal the box.

Sawmill Control Box Component Installation

9. Remove the rear panel from the sawmill control box (leave wire connections).
10. Remove the two small bolts and nuts from the back of the control box.
11. Install the provided 15 Amp breaker to the two small holes in the back of the control box (reset tab up). Replace the screws and nuts to secure the breaker to the back panel.

See Figure 2-14.

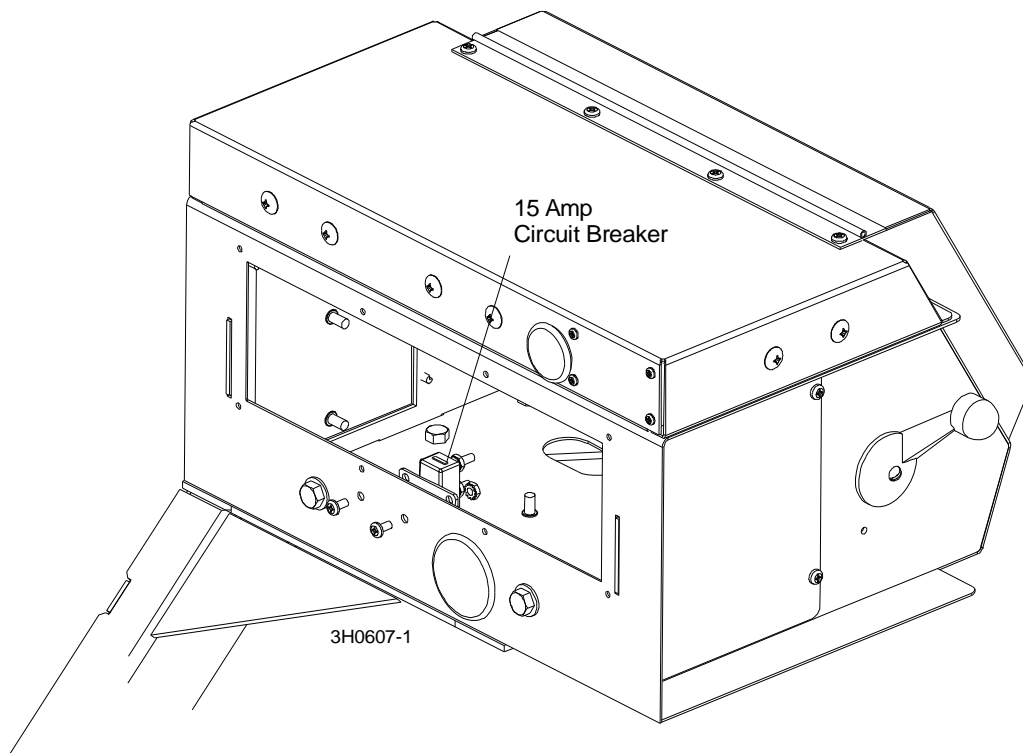

FIG. 2-14

2 Debarker Installation

Control Component Installation (Remote Mills)

12. Using the back side of the front panel for a guideline, cut out holes in the front panel lexan decal for the debarker switches. Install the provided toggle switches, 1/16" nylon washers, and rubber boots in place as shown.

See Figure 2-15.

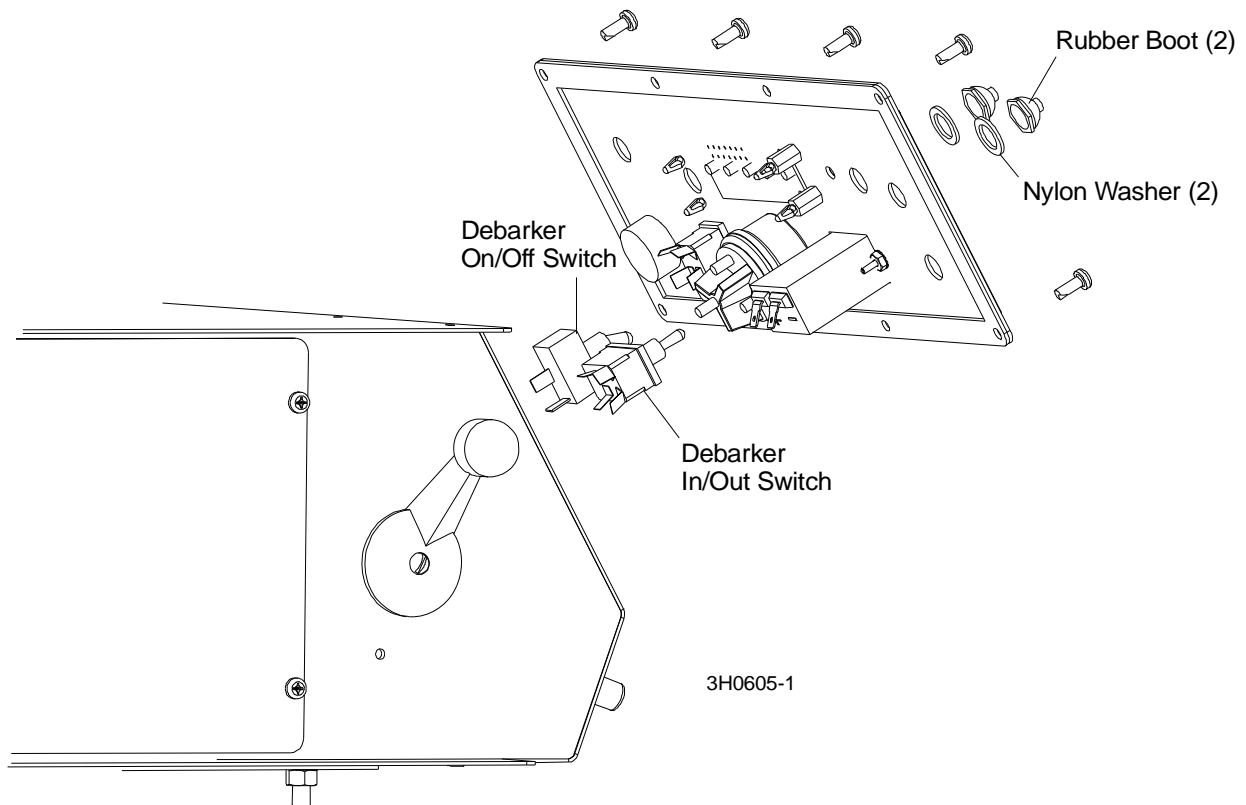
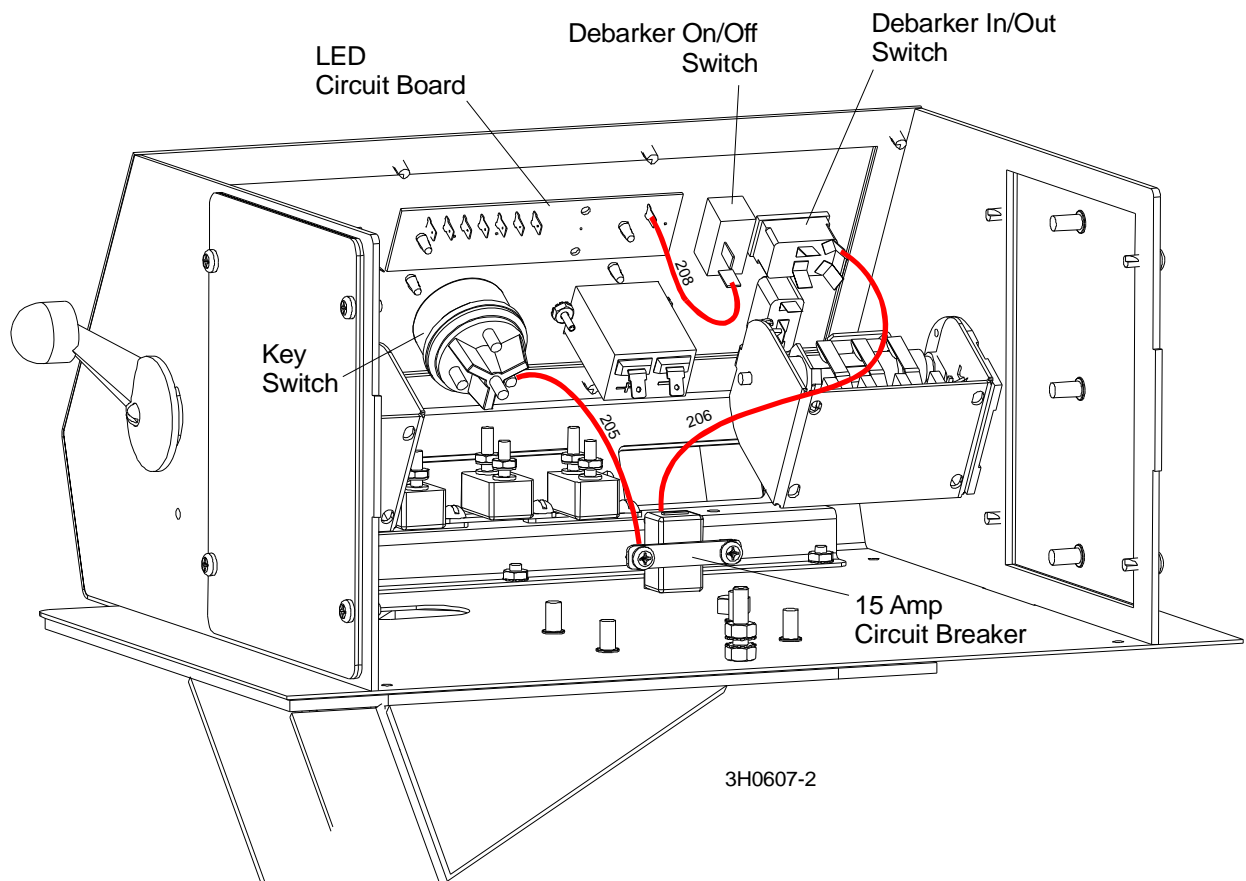

FIG. 2-15

13. Connect the red #205 wire from the 15 Amp breaker to the ACC post on the key switch.
14. Make sure the red #206 wire from the 15 Amp breaker to the debarker in/out switch is connected.
15. Connect the red #208 wire from the debarker on/off switch to the DBKR terminal on the LED board.

See Figure 2-16. Box housing removed for clarity. Only wires referred to above are shown.

**FIG. 2-16**

2

Debarker Installation

Control Component Installation (Remote Mills)

16. Connect the red #200 wire from the debarker on/off switch to terminal #2 of the power feed drum switch.
17. Connect the black #207 wire from the debarker in/out switch to the rear ground stud.
18. Locate the bundle of wires on the floor of the sawmill control box. Make sure the debarker in/out switch is oriented horizontally as shown.
19. Connect the small red #21 wire to the debarker in/out switch bottom left terminal.
20. Connect the small black #22 wire to the debarker in/out switch top left terminal.
21. Connect the small red #33 wire to the male terminal extension on the debarker on/off switch bottom terminal.
22. Reinstall the control box panels.

See Figure 2-17. Box housing removed for clarity. Only wires referred to above are shown.

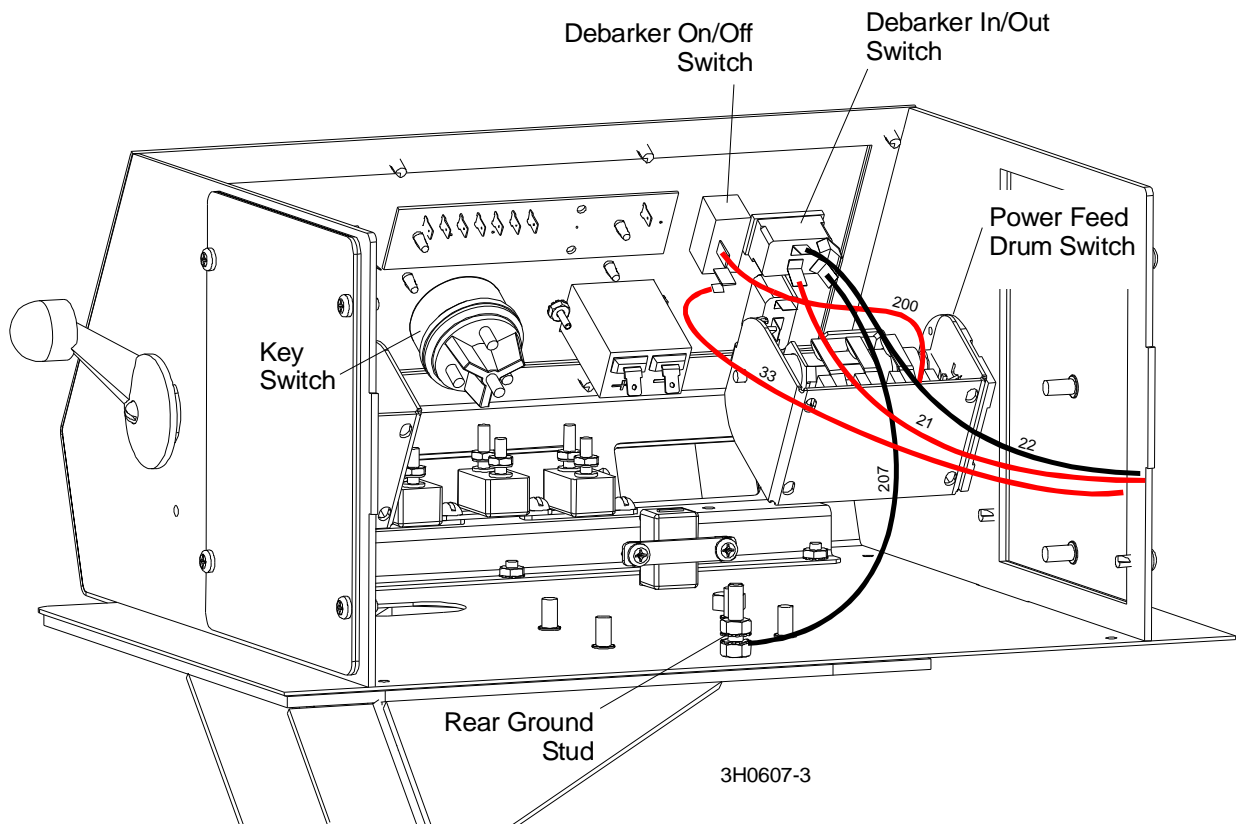

FIG. 2-17

2.6 Alignment



DANGER! Before performing any service to this equipment, turn the key to the OFF (0) position and remove the key. Failure to do so will result in serious injury or death.

Two adjustments are required for proper debarker operation:

- The debarker blade should be centered with the sawmill blade.
 - The debarker blade should remain parallel to the sawmill blade throughout the debarker's range of motion.
1. Turn the key to ACC (3) and use the debarker in/out switch to move the debarker all the way in. Turn the key to OFF (0) and remove the key. This will prevent the debarker from being turned on while performing alignment procedures.
 2. Clip the blade guide alignment tool to the sawmill blade. Make sure the tool lies flat on the blade and does not contact a tooth that could cause it to angle.

See Figure 2-18.

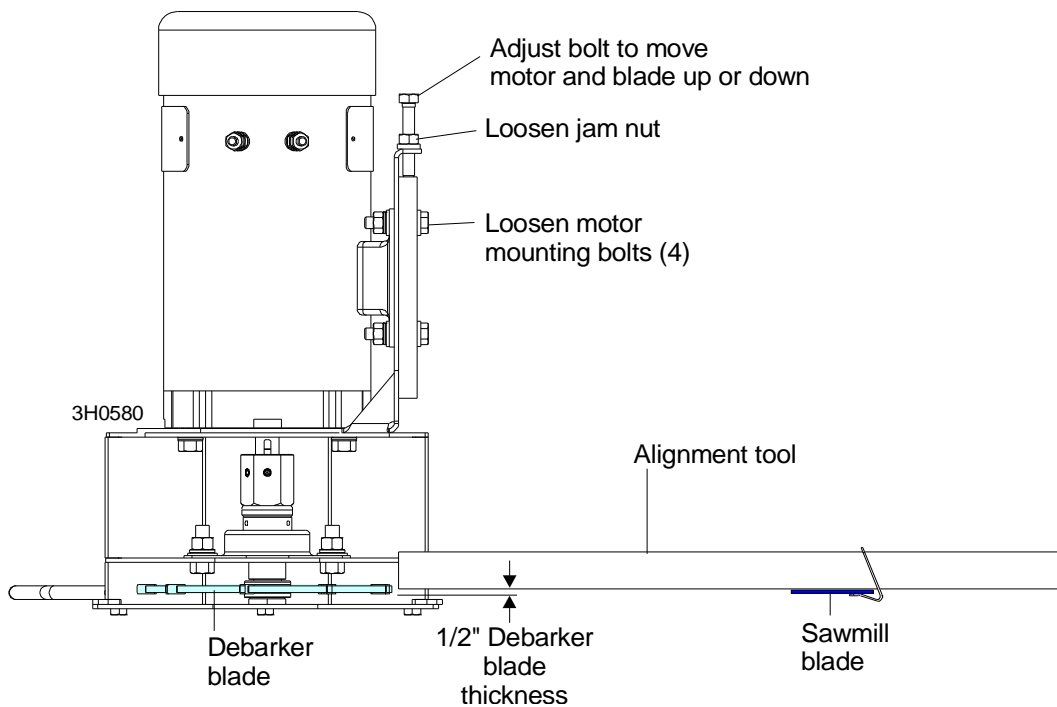

FIG. 2-18

2

Debarker Installation

Alignment

3. Check the height of the debarker blade against the alignment tool. The bottom edge of the tool should align with the center of the debarker blade.

To adjust the blade up or down, loosen the four blade motor mount bolts. Loosen the jam nuts on the adjustment bolts. Turn the adjustment bolts clockwise to push the motor and blade down. Turn the adjustment bolts counterclockwise and slide the motor up to raise the motor and blade. Retighten the adjustment bolts jam nuts and four motor mount bolts.

4. Insert the key and use the debarker in/out switch to move the debarker all the way out. Turn the key to OFF (0) and remove the key.

SECTION 3 OPERATION AND MAINTENANCE

3.1 Locking Pin Operation

See Figure 3-1. The debarker is equipped with a locking pin located where the debarker frame pivots in the mounting blocks. Two hole locations are provided for the locking pin. The inner hole should be used to lock the debarker in place when towing the sawmill. The outer position can be used to hold the debarker out of the way when debarking is not required during sawing.

Before operating the debarker, make sure the locking pin is secured in its disengaged position. Turn the key switch to OFF (0) and remove the key. Pull the debarker out to relieve pressure on the locking pin. Pull the pin down and rotate so the small roll pin is aligned with the disengaged position slot. Release the locking pin.

Before towing the sawmill, lock the debarker in the travel position. Turn the key switch to ACC (3) and use the debarker in/out switch to move the debarker all the way in. Turn the key to OFF (0) and remove the key. Push the debarker in until the travel position hole aligns with the locking pin. Pull the pin down and rotate until the small roll pin is aligned with the engaged position slot. Release the locking pin.

To move the debarker out of the way during sawing, turn the key switch to ACC (3) and use the debarker in/out switch to move the debarker all the way out. Turn the key to OFF (0) and remove the key. Push the debarker out until the outer hole is aligned with the locking pin. Pull the pin down and rotate until the small roll pin is aligned with the engaged position slot. Release the locking pin.

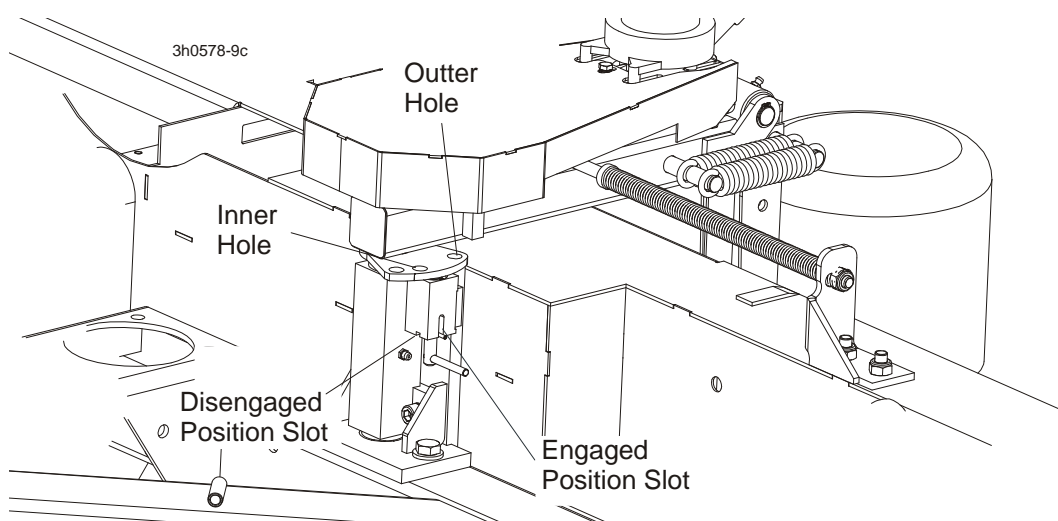

FIG. 3-1

3 Operation and Maintenance

Operation

3.2 Operation

The Debarker Option allows you to remove bark from logs before cutting.



DANGER! Make sure all guards and covers are in place and secured before operating the debarker option. Failure to do so may result in serious injury.

DANGER! Keep all persons out of the path of moving equipment when operating the debarker. Failure to do so will result in serious injury.

1. Remove the blade motor cover before operating the debarker.
2. Use the in/out switch on the control box to pivot the debarker all the way out.
3. Move the sawmill carriage forward and pivot the debarker in until the front fence engages with the end/side of the log. Continue to pivot the debarker in until the spring arm is fully loaded and the spring rod will not extend any further through the mounting bracket.

See Figure 3-2.

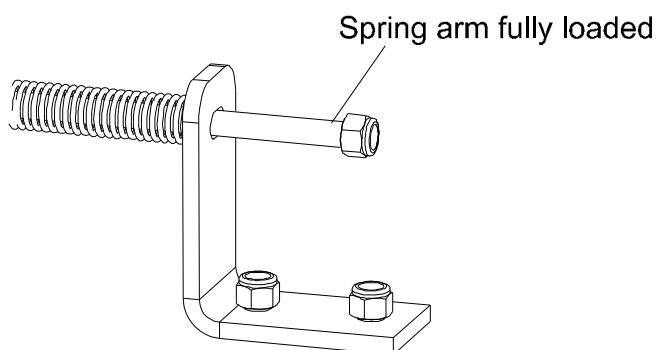

3H0208

FIG. 3-2

4. Turn the debarker on/off switch to ON (1).
5. Proceed with cutting. The spring will keep the debarker against the side of the log. Depending on log shape, you may have to pivot the debarker in and out for smooth cutting.



NOTE: The debarker can continuously remove up to approximately 1” of material from the log; no motor cool down time is required. Slower feed rates may be required for optimal debarker operation.

6. Once the carriage is past the end of the log, pivot the debarker away from the log. Return the carriage.



IMPORTANT! Should the carriage be returned before the debarker has been pivoted out of the way of the log, the debarker is designed to pivot upwards. If this happens, continue to **SLOWLY** return the carriage; or stop, pivot the debarker out and then return the carriage. **DO NOT** move the carriage forward while the debarker is contacting the log without the blade spinning.

7. When done sawing and ready to store or transport the sawmill, replace the debarker blade motor cover. Place the debarker in its travel position before towing the sawmill ([See Section 3.1](#)).

3.3 Maintenance

 **DANGER!** Before performing any service to this equipment, turn the key to the OFF (0) position and remove the key. Failure to do so will result in serious injury or death.

1. Lubricate the two pivot joints with a NLGI #2 grade lithium grease every 40 hours of operation.

See Figure 3-3.

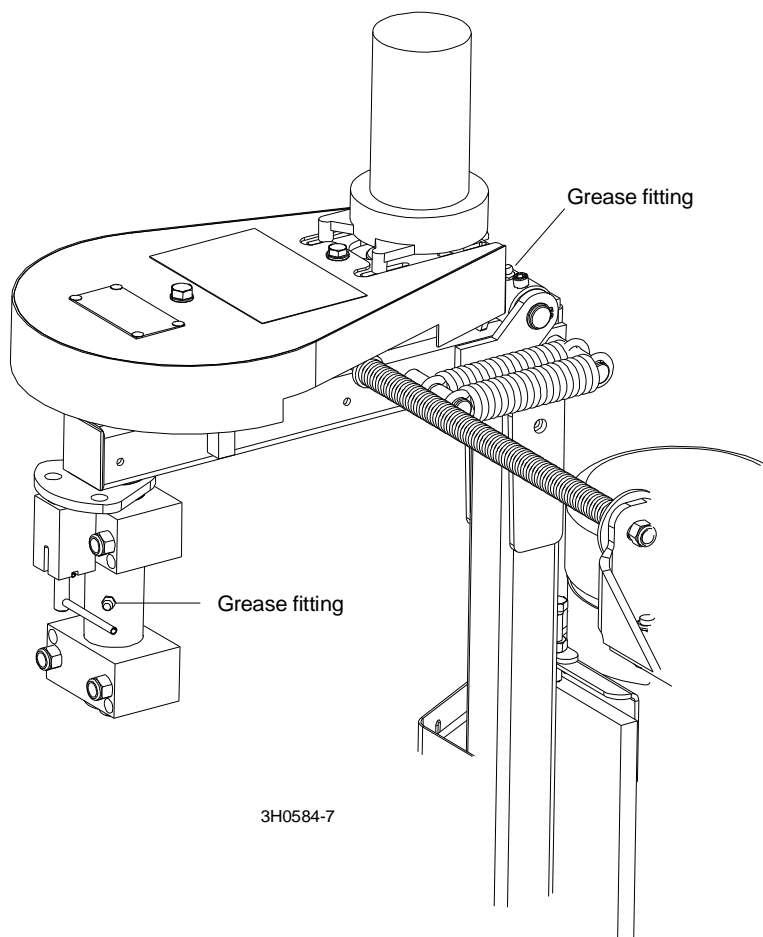

FIG. 3-3

2. Periodically check the flexible guard. Adjust the guard up or down so the bottom is even with the bottom of the debarker blade. Replace the guard as needed.

3. Periodically check the debarker blade. Align or replace as needed.



WARNING! Before replacing the debarker blade, move the sawmill blade guide arm in front of the sawmill blade to cover the blade teeth. Failure to do so may result in serious injury or death.

To replace the debarker blade, remove the lower blade guard plate. Place one wrench on the blade arbor, above the blade bearing. Place the other wrench on the lower bolt and rotate clockwise (bolt has left-hand threads). Remove the bolt and washer. Remove the blade and spacer.

Reinstall the spacer with the new blade. Reinstall the bolt and washer and turn counterclockwise to tighten. Reinstall the blade guard plate.

4. Periodically check belt for tension and wear. Adjust or replace as necessary. To tighten the belt, turn the key switch to OFF (0) and remove the key. Remove the belt guard and loosen the four motor mount screws. Turn the adjustment nut clockwise to move the motor out and tighten the belt. The belt should be tensioned to allow 9.5 mm (3/8") deflection measured halfway between the pulleys with 1.3-2.2 kg (3-5 lbs). of force. Retighten the motor mount screws and replace the belt guard.

See Figure 3-4.

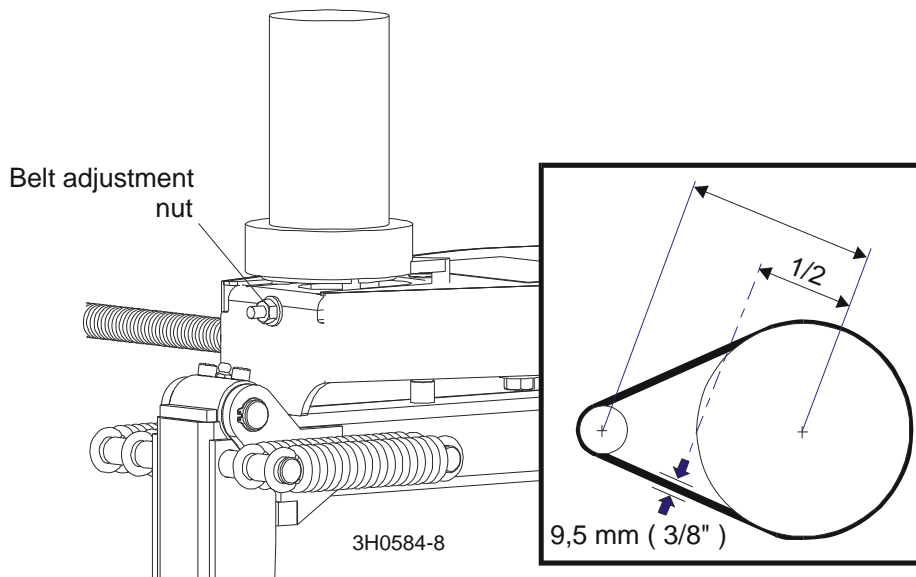

FIG. 3-4

5. Apply a dry lubricant such as Teflon spray or silicon to the spring rod and spring every 40 hours of operation.

3.4 Troubleshooting



DANGER! Before performing any service to this equipment, turn the key to the OFF (0) position, remove the key, and disconnect the sawmill battery ground terminal. Failure to do so will result in serious injury or death.

PROBLEM	CAUSE	SOLUTION
70 amp circuit breaker tripping	Wood or bark jammed in blade guard	Turn key to OFF position, remove key. Remove wood or bark from blade guard
	Pivot pin is binding.	Inspect for bind by moving debarker head to full in position. Turn key to OFF position, remove key. Pull arm to full out position by hand. If available, use a weight scale to pull arm to full out position. Should not have more than 12 pounds of resistance to pull out. Ensure pivot pin has been greased properly. Check pivot clamps for correct installation. Loosen pivot clamp bolts slightly, check for reduced binding
	Ring terminal of red wire touching debarker motor housing at motor	Move terminal away from motor housing. Reset circuit breaker and retest.
Light comes on, but debarker motor and warning horn do not operate	Circuit breaker weak from repeated tripping.	Replace circuit breaker
	Circuit breaker tripped	Reset circuit breaker.
Debarker shuts off, but the circuit breaker is not tripped.	Bad ignition wire connection	Check ignition wire connection outside and inside of debarker control box.
	Intermittent key switch	Replace key switch
	Other loose wiring connection	Check wiring connections inside control box.
Debarker will not shut off.	Solenoid is stuck closed.	Replace solenoid.
IN/OUT Motor does not move IN or OUT	Drive belt too loose	Tighten enough to allow movement. DO NOT OVER-TIGHTEN.
	Switch not working properly	Check wiring to switch for loose connections. If wiring looks OK, replace switch.

SECTION 4 DEBARKER PARTS

4.1 How To Use The Parts List

- Use the table of contents or index to locate the assembly that contains the part you need.
- Go to the appropriate section and locate the part in the illustration.
- Use the number pointing to the part to locate the correct part number and description in the table.
- Parts shown indented under another part are included with that part.
- Parts marked with a diamond (◆) are only available in the assembly listed above the part.

See the sample table below. Sample Part #A01111 includes part F02222-2 and subassembly A03333. Subassembly A03333 includes part S04444-4 and subassembly K05555. The diamond (◆) indicates that S04444-4 is not available except in subassembly A03333. Subassembly K05555 includes parts M06666 and F07777-77. The diamond (◆) indicates M06666 is not available except in subassembly K05555.

4.2 Sample Assembly				
REF.	DESCRIPTION (◆ Indicates Parts Available In Assemblies Only)	PART #	QTY	
	SAMPLE ASSEMBLY, COMPLETE (INCLUDES ALL INDENTED PARTS BELOW)	A01111	1	
6	Sample Part	F02222-22	1	
	Sample Subassembly (Includes All Indented Parts Below)	A03333	1	
7	Sample Part (◆ Indicates Part Is Only Available With A03333)	S04444-4	1	◆
	Sample Subassembly (Includes All Indented Parts Below)	K05555	1	
8	Sample Part (◆ Indicates Part Is Only Available With K05555)	M06666	2	◆
9	Sample Part	F07777-77	1	

To Order Parts:

- From Europe call our European Headquarters and Manufacturing Facility in Kolo, Poland at **+48-63-2610233** or **+48-3912-1319**. From the continental U.S., call **1-800-448-7881** to order parts. Have your customer number, vehicle identification number, and part numbers ready when you call.
- From other international locations, contact the Wood-Mizer distributor in your area for parts.

4 Debarker Parts

Locking Pin Assembly

4.3 Locking Pin Assembly

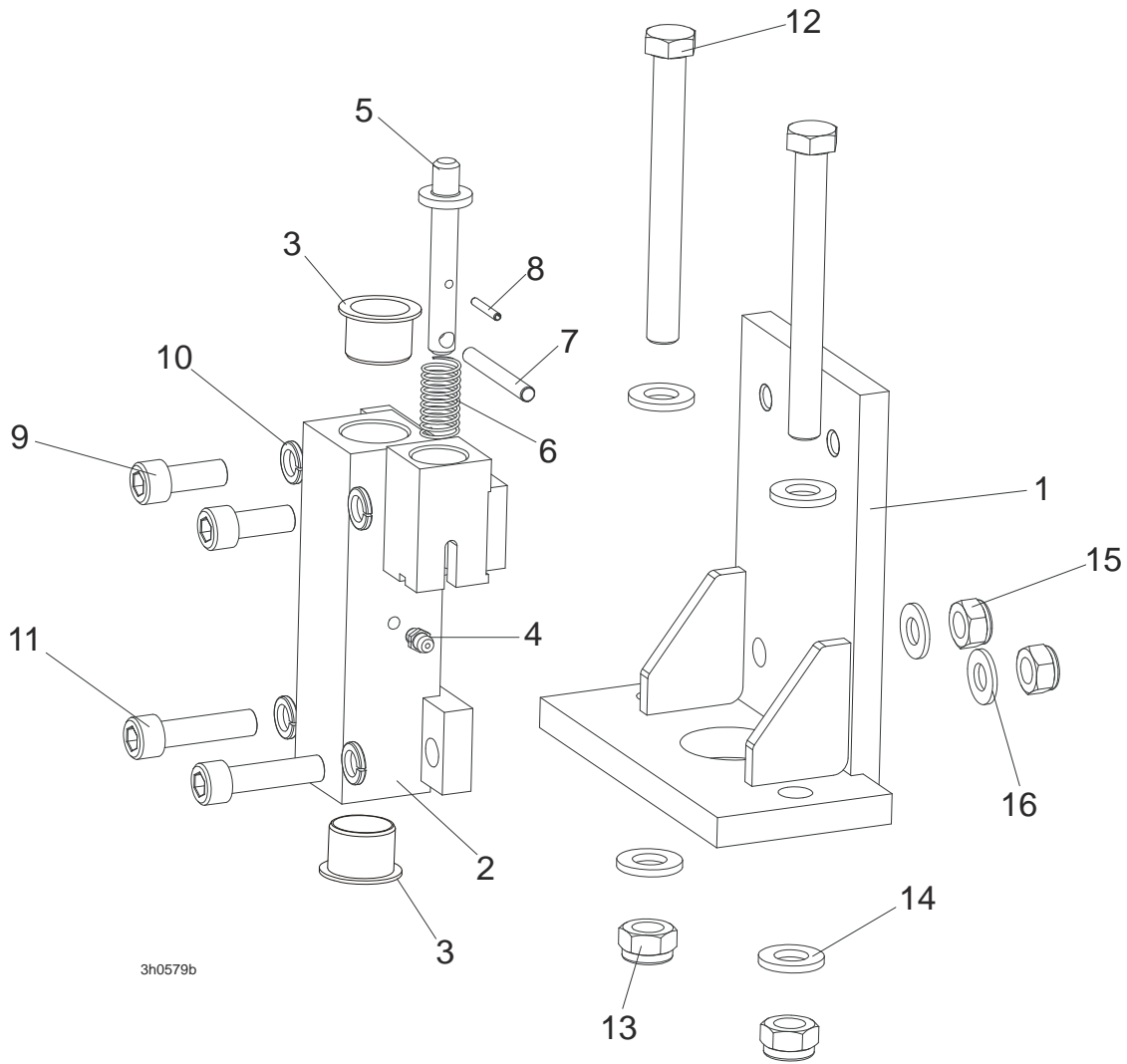

3h0579b

REF.	DESCRIPTION (◆ Indicates Parts Available In Assemblies Only)	PART #	QTY	
1	PLATE, LT60/70/80 MOUNTING	089942-1	1	
2	ARM, DEBARKER FRAME PIVOT	089947-1	1	
	ARM, DEBARKER FRAME PIVOT	091008	1	
3	BUSHING, GFM - 2528 - 21	091009	2	
4	FITTING, M6 STRAIGHT GREASE	086280	1	
5	PIN, DEBARKER LOCKING	089972-1	1	
6	SPRING, .58" OD X 1 1/8"	021243	1	
7	PIN, 6X50 ROLL ZINC	F81045-1	1	
8	PIN, 3X20 ROLL ZINC	F81044-5	1	
9	BOLT M10X30-5.8	F81003-2	2	
10	WASHER, 10.5 ZINC FLAT	F81055-2	4	

11	SCREW, M10X40 8.8 HEX SOCKET HEAD CAP ZINC	F81003-22	2	
12	BOLT M12X55 -8.8-B-FE/ZN5	F81004-23	2	
13	NUT, M12-8, SELF LOCKING	F81034-2	2	
14	WASHER, 13 ZINC FLAT	F81056-1	4	
15	NUT, M10-8-B HEX NYLON ZINC LOCK	F81033-1	2	
16	WASHER, 10.5 ZINC FLAT	F81055-1	2	

4 Debarker Parts

Frame Assembly

4.4 Frame Assembly

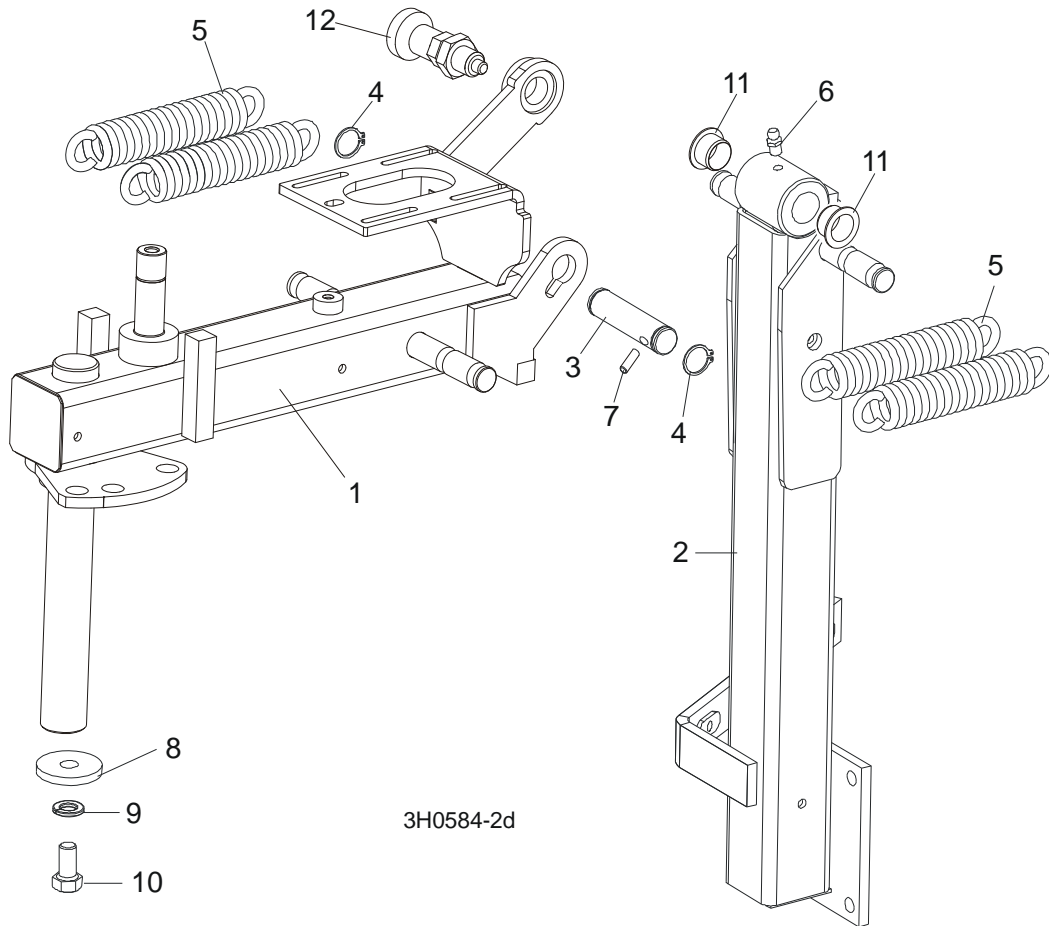

REF.	DESCRIPTION (◆ Indicates Parts Available In Assemblies Only)	PART #	QTY
1	ARM WELDMENT, DEBARKER HORIZONTAL	089963-1	1
2	ARM WELDMENT, DEBARKER VERTICAL	089966-1	1
3	PIN, VERTICAL ARM PIVOT	089588-1	1
4	RING, Z16 OUTER RETAINING	F81090-11	2
5	SPRING, DEBARKER ARM	021185	4
6	FITTING, M6 GREASE	086280	1
7	PIN, H 5X12-B ROLL ZINC	F81044-8	1
8	WASHER, .40 X 1.44 X .18	089973-1	1
9	WASHER, 3/8" SPLIT LOCK	F81055-2	1
10	BOLT, 3/8-16 X 3/4" HEX HEAD GRADE 2	F81003-1	1
11	BUSHING, GFM - 1618-12	091455	2
12	PIN, 45308DNW DETENT	089939	1

4.5 In/Out Motor Drive Assembly

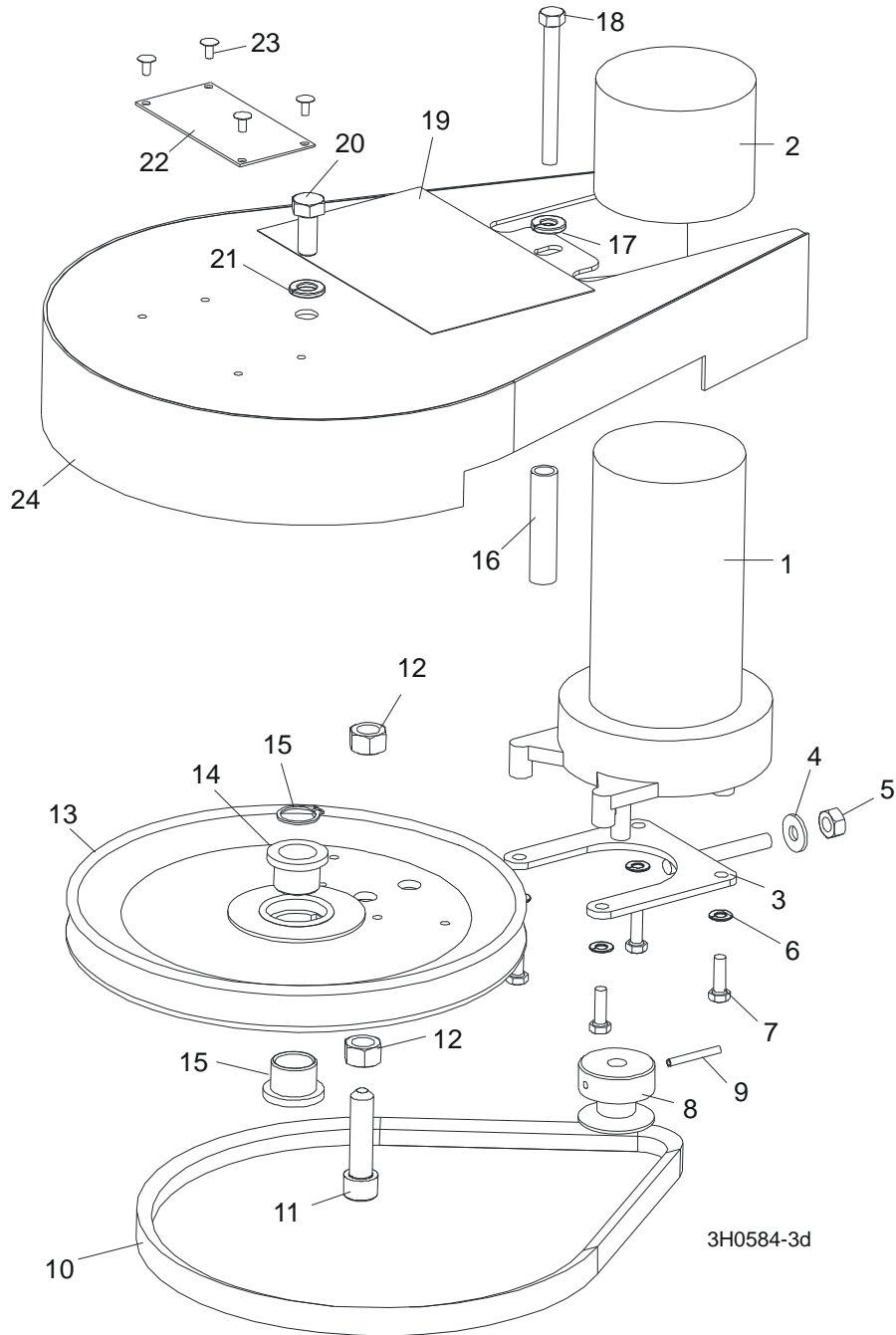

REF.	DESCRIPTION (◆ Indicates Parts Available In Assemblies Only)	PART #	QTY
1	MOTOR, 53:1 GEAR	P09698-1	1
	Gear Kit, Klauber Motor Replacement	P12569	1
	Shaft Kit, Klauber Motor Replacement	009695	1

4

Debarker Parts*In/Out Motor Drive Assembly*

2	CAP, IN/OUT MOTOR WEATHER RUBBER	023720	1	
3	TENSIONER WELDMENT, DEBARKER IN/OUT MOTOR PAINTED	089969-1	1	
4	WASHER, 6.5 ZINC FLAT	F81053-11	1	
5	NUT, M6-8 ZINC HEX	F81031-1	1	
6	WASHER, 5.1 ZINC SPLIT LOCK	F81052-2	4	
7	BOLT, #10-32X1/2" HEX HEAD ZINC	F05004-60	4	
8	SHEAVE, DEBARKER MOTOR ZINC-PLATED	089954-1	1	
9	PIN, 1/8X3/4" ROLL	F05012-6	1	
10	BELT AVX 13X800	089986	1	
11	SCREW, M10X40 8.8 HEX SOCKET HEAD CAP ZINC	F81003-22	1	
12	NUT, M10-8-B ZINC HEX	F81033-3	2	
13	PULLEY, DEBARKER MOTOR	091154-1	1	
14	BUSHING, FLANGED BRONZE	089948	2	
15	RING, Z16 SPRING RETAINING	F81090-11	1	
16	SPACER, ZINC-PLATED	089949-1	1	
17	WASHER, Z 6.1 ZINC SPLIT LOCK	F81053-3	1	
18	BOLT, M6X80 5.8 HEX HEAD FULL THREAD ZINC	F81001-61	1	
19	DECAL, WARNING	021172	1	
20	BOLT, M8X16-8.8-B HEX HEAD FULL THREAD ZINC	F81002-20	1	
21	WASHER, 8.2 ZINC SPLIT LOCK	F81054-4	1	
22	PLATE, DEBARKER REVISION	005801-293	1	
23	RIVET, 1/8" X 1/4" ALUMINIUM POP	F04203-2	4	
24	GUARD WELDMENT, DEBARKER V-BELT PAINTED	090519-1	1	

4.6 Blade Motor Assembly

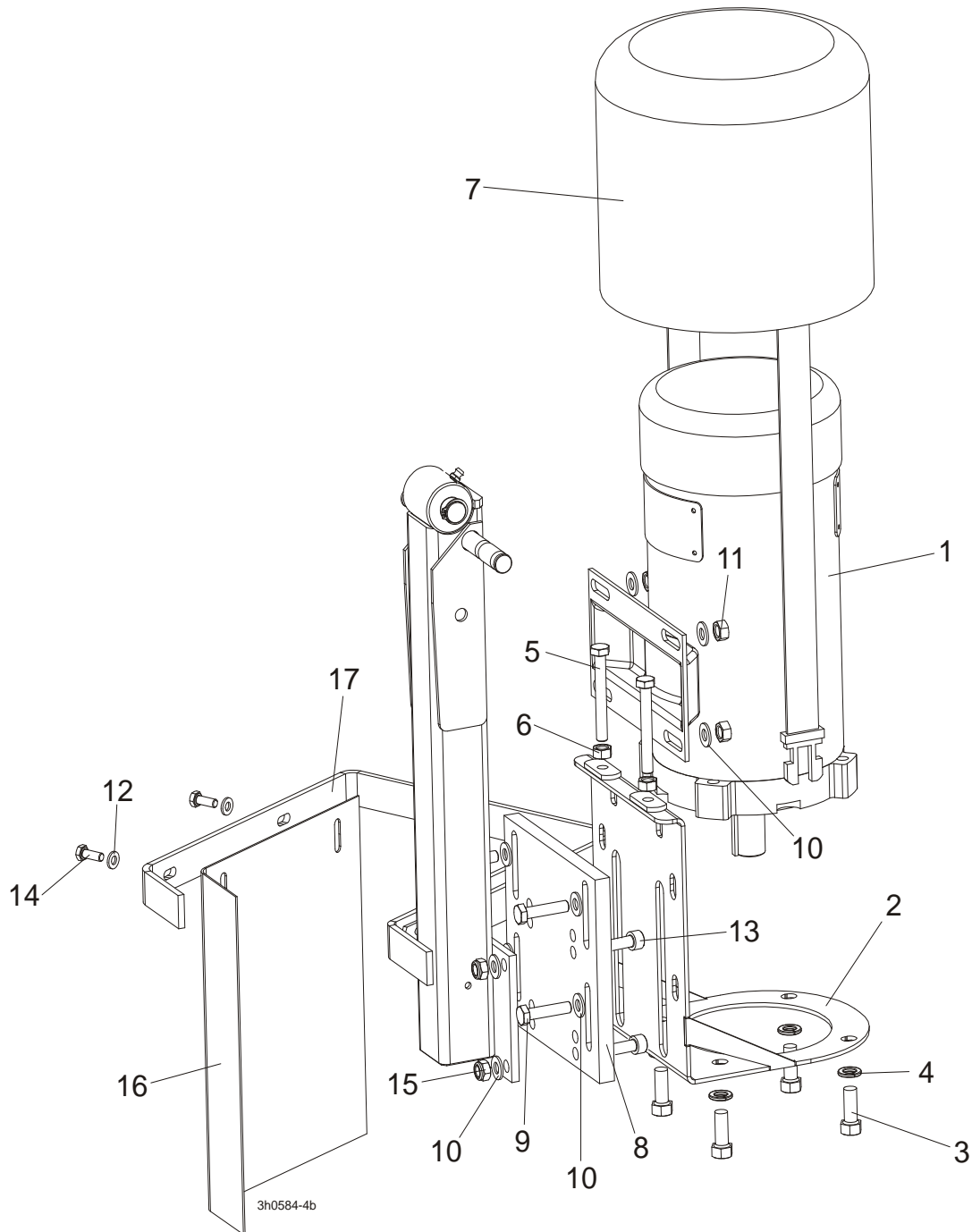

REF.	DESCRIPTION (◆ Indicates Parts Available In Assemblies Only)	PART #	QTY	
	HEAD ASSEMBLY, DC DEBARKER	089792	1	
	Debarker Blade Motor Assembly	089789	1	

4**Debarker Parts***Blade Motor Assembly*

1	Motor, Leeson, 3/4 HP 12VDC TEFC	023688	1	
2	Bracket, DC Debarker Motor Mount	089788-1	1	
3	Bolt, 3/8-16 x 1" Hex Head	F05007-7	4	
4	Washer, 10.2 Zinc Split Lock	F81055-2	4	
5	Bolt, M8X65 8.8 Hex Head Full Thread Zinc	F81002-9	2	
6	Nut, M8-8-B Hex Zinc	F81032-1	2	
7	Guard, 3/4HP Leeson Motor	015761	1	
8	Plate, Debarker Motor Mounting	089551	1	
9	Bolt, M8x35-8.8 Hex Head Full Thread Zinc	F81002-13	4	
10	Washer, 8.4 Zinc Flat	F81054-1	4	
11	Nut, M8-8-B Hex Zinc	F81032-1	4	
12	Washer, 6.4 Zinc Flat	F81053-1	2	
13	BOLT, M8X30 -8.8 SOCKET HEAD	F81002-31	4	
14	BOLT, M6 X 16 8.8 HEX HEAD FULL THREAD ZINC	F81001-15	5	
15	NUT, M8 8 HEX	F81032-2	4	
16	GUARD, DEBARKER FLEXIBLE DEBRIS	089562	1	
17	GUARD, DEBARKER WRAP-AROUND PAINTED	089561-1	1	

4.7 Blade Housing Assembly

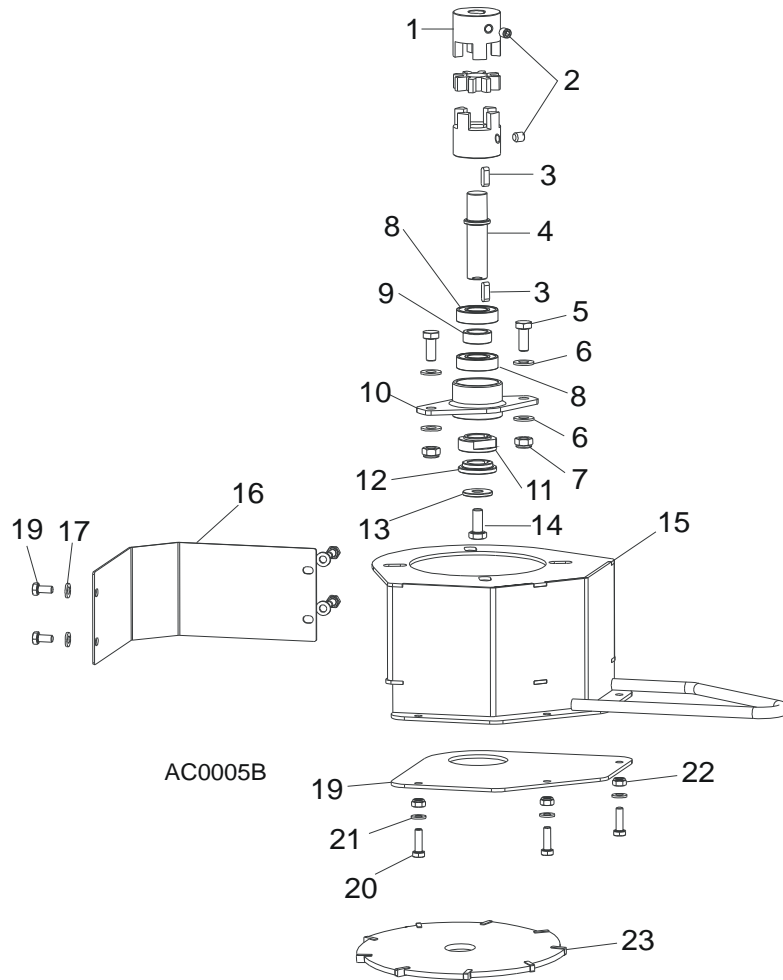

REF.	DESCRIPTION (◆ Indicates Parts Available In Assemblies Only)	PART #	QTY
1	SPIDEX CLUTCH 19/24 B/B ST 92SH	088542	1
2	SCREW M8 X 8-33H	F81014-1	2
3	KEY 5H9 X 5 X 17	086279	2
4	SHAFT, AC DEBARKER CLUTCH	086507	1
5	BOLT, M8 X 20 8.8 B HEX HEAD	F81002-4	2
6	WASHER, 8.4 FLAT	F81054-1	2
7	NUT, M8 8 HEX	F81032-2	2
8	BEARING 6003-2RS-P66	086116	2
9	SPACER, AC DEBARKER CLUTCH	086357	1
10	BUSHING, AC DEBARKER CLUTCH BEARING	086354	1
11	BUSHING, AC DEBARKER CLUTCH CLAMP	086355	1

4**Debarker Parts***Blade Housing Assembly*

12	BUSHING, AC DEBARKER CLUTCH	086356	1	
13	WASHER, 8.5 MM	086363	1	
14	BOLT, M8 X 20 - 8.8 HEX HEAD	F81002-4	1	
15	HOUSING WELDMENT, DEBARKER BLADE	086366-1	1	
16	GUARD, DEBARKER CLUTCH	086372-1	1	
17	WASHER, 6.4 SPLIT LOCK	F81053-1	4	
18	BOLT, M6 X 12 8.8 HEX HEAD	F81001-7	4	
19	GUARD, AC DEBARKER LOWER	086371-1	1	
20	BOLT, M6 X 20 - 8.8 HEX HEAD	F81001-2	3	
21	WASHER,6.4 SPLIT LOCK	F81053-1	3	
22	NUT, M6 8.8 HEX	F81031-2	3	
23	BLADE, DEBARKER 7" DIA.	021236	1	

4.8 Debarker Control Assembly

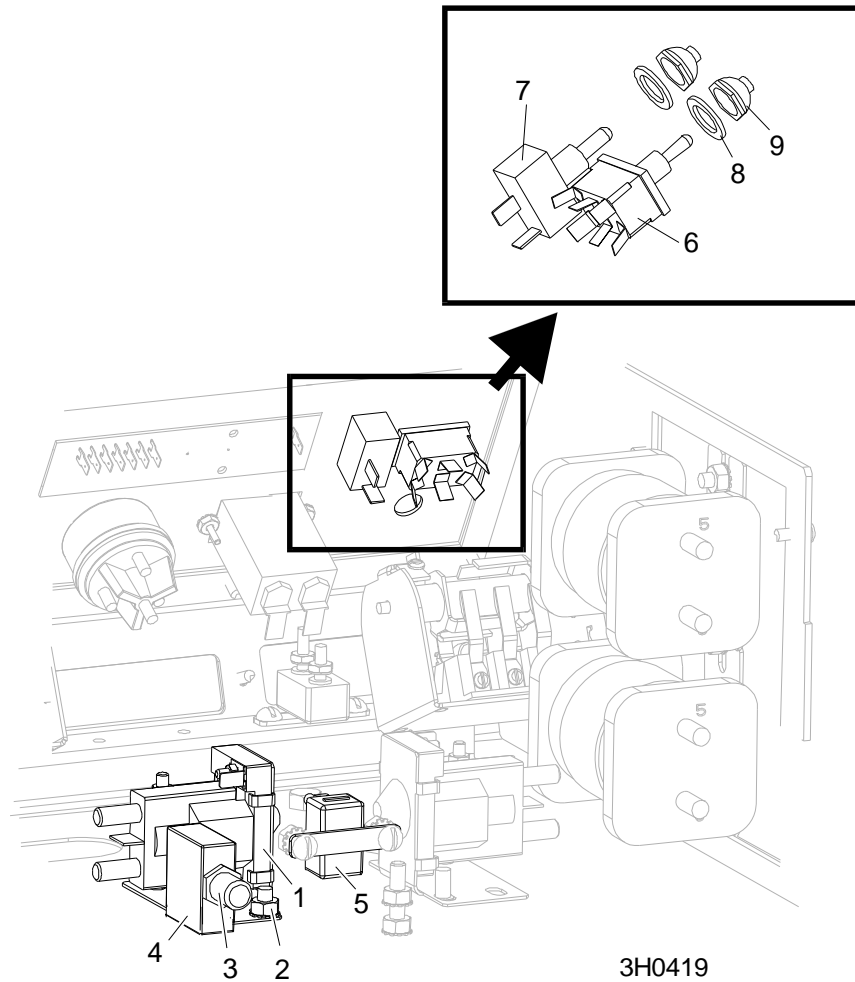

REF.	DESCRIPTION (◆ Indicates Parts Available In Assemblies Only)	PART #	QTY
	CONTROL ASSEMBLY, DEBARKER (NON-REMOTE)	023676	1
	CONTROL ASSEMBLY, DEBARKER (REMOTE)	023677	1
1	Solenoid, 12V 100A Continuous Duty GND Coil	P10449	1
	Diode Assembly, Solenoid GND Coil Chassis	015426	1
2	Nut, 1/4-20 Self-Locking	F05010-9	2
3	Boot, Circuit Breaker	021253	1
4	Breaker, 70 Amp Manual Reset Panel Mount	015527	1
5	Breaker, 15 Amp Manual Reset	E20430	1
6	Switch, DPDT Toggle Return Center Screw Terminal	024200	1
7	Switch, SPST Toggle Quick Connect	P03027	1
8	Washer, 1/2 x 3/4 x 1/16" Nylon	P05251-1	2
9	Boot, Toggle Switch	P02575	2

4 Debarker Parts

Spring Rod Assembly

4.9 Spring Rod Assembly

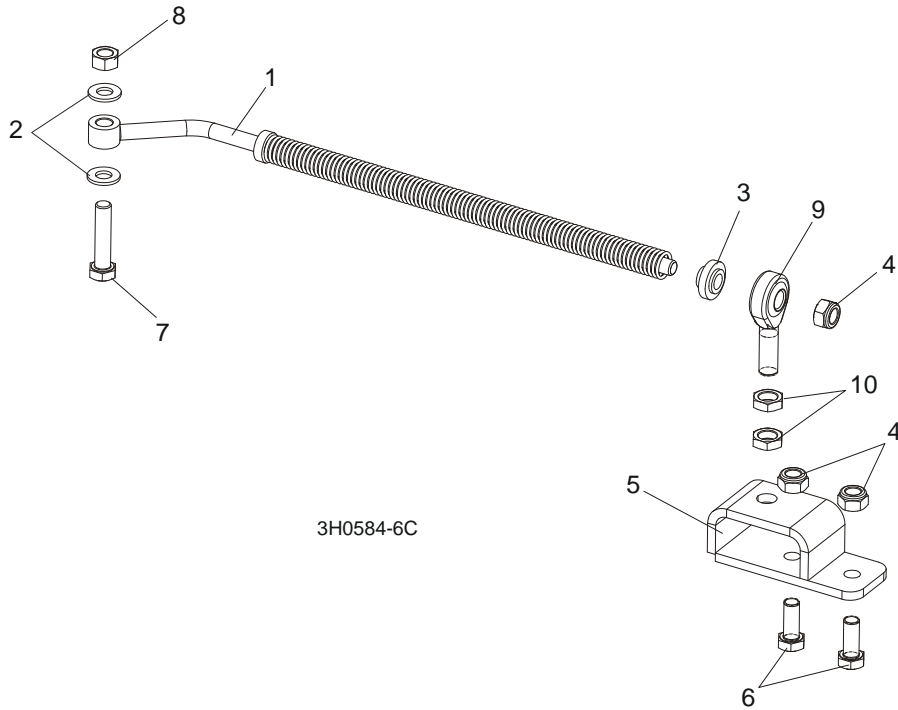

REF.	DESCRIPTION (◆ Indicates Parts Available In Assemblies Only)	PART#	QTY
	ROD, ZINC-PLATED	089974	1
1	Rod, Debarker Spring Zinc-plated	089979-1	1
2	Washer, 10.5 Zinc Flat	F81055-1	2
3	Washer, Fender Zinc	089982-1	1
4	Nut, M10-8-B Hex Nylon Zinc Lock	F81033-1	3
5	Bracket, Dbk Spring Rod Mounting Painted	092238-1	1
6	Bolt, M10x25-8.8 Hex Head Full Thread Zinc	F81003-11	2
7	Bolt, M10x45-8.8 Hex Head Full Thread Zinc	F81003-3	1
8	Nut, M10-8-B-FE	F81033-3	1
9	Rod End, SA12 CX Right-Hand	087035	1
10	Nut, M12-04-A Thin Zinc-Plated	F81034-6	2

4.10 Wider Debarker Assembly

525865_001
525865_MANUAL

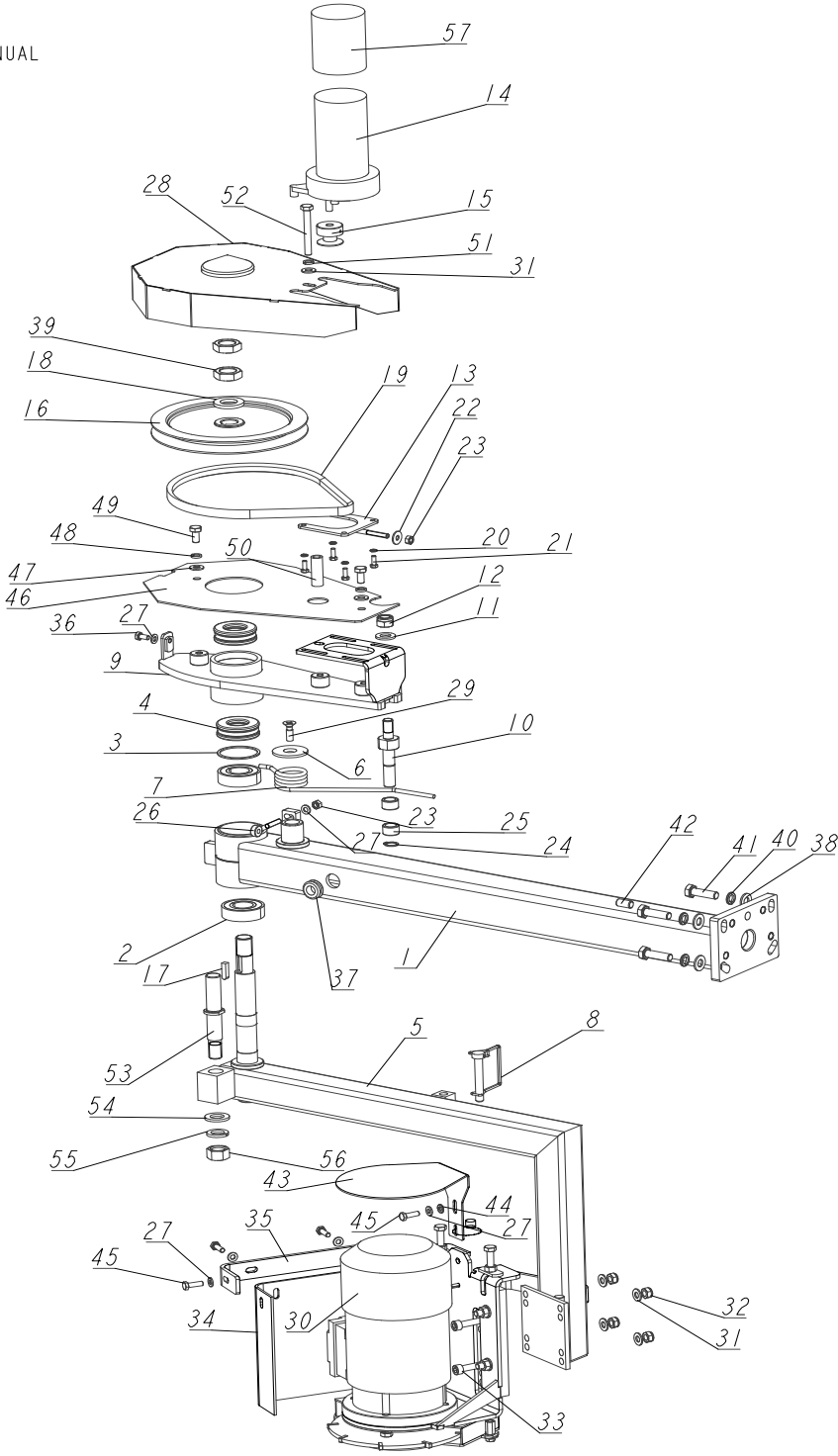

4

Debarker Parts*Wider Debarker Assembly*

REF.	DESCRIPTION (◆ Indicates Parts Available In Assemblies Only)	PART#	QTY	
-	LT70 AC DEBARKER - WIDER	525865	1	
-	LT70 DC DEBARKER - WIDER	525864	1	
1	ARM, DEBARKER HORIZONTAL	525867-1	1	
2	BEARING, 6205 2RS BALL	091804	2	
3	RING, SPACER	098491-1	1	
4	BEARING, 51305 THRUST	098597	2	
5	ARM, DEBARKER SWING	526624-1	1	
6	PLATE, SPRING BUSHING	098592-1	1	
7	SPRING, DEBARKER RETAINING	098605	1	
8	PIN, 3/8X2 1/4 SQ WIRE LOCK	014151	1	
9	ARM WELDMENT, DEBARKER	098626-1	1	
10	PIN, DEBARKER	098593-1	1	
11	WASHER, 13 FLAT ZINC	F81056-1	1	
12	NUT, M12 8 HEX NYLON ZINC LOCK	F81034-2	1	
13	TENSIONER WELDMENT, DEBARKER MOTOR	089969-1	1	
14	MOTOR, CURRENT APP. 1/30HP RPM32, 12VDC R	079214M	1	
15	SHEAVE, DEBARKER MOTOR ZINC-PLATED	089954-1	1	
16	PULLEY, DEBARKER MOTOR	098594-1	1	
17	KEY, 6X6X23	089191	1	
18	WASHER, 21 FLAT ZINC	F81059-2	1	
19	BELT, 4L280	P04031	1	
20	WASHER, 5.1 SPLIT LOCK	F81052-2	4	
21	BOLT, #10-32X1/2" HEX HEAD	F05004-60	4	
22	WASHER, 6.5 SPECIAL FLAT ZINC	F81053-11	1	
23	NUT, M6-8 HEX ZINC	F81031-1	2	
24	RING, Z14 OUTSIDE RETAINING	F81090-31	1	
25	BEARING, 1412 NEEDLE	098595	2	
26	BOLT, M6 EYE	098596	1	
27	WASHER, 6.4 FLAT ZINC	F81053-1	6	
28	GUARD, DEBARKER V-BELT	098598-1	1	
29	SCREW, M8X25-5.8 CROSS RECESSED COUNTERSUNK HEAD ZINC	F81002-51	1	
30	DRIVE ASSEMBLY, DEBARKER BLADE - AC See Section 4.11	096239	1	
	DRIVE ASSEMBLY, DEBARKER BLADE - DC See Section 4.12	100922	1	
31	WASHER, 8.4 FLAT ZINC	F81054-1	5	
32	NUT, M8-8-B HEX NYLON ZINC LOCK	F81032-2	4	
33	SCREW, M8X30-8.8 HEX SOCKET HEAD CAP ZINC	F81002-31	4	
34	GUARD, DEBARKER FLEXIBLE DEBRIS	097020	1	
35	GUARD, DEBARKER WRAP-AROUND	098695-1	1	
36	BOLT, M6X12 8.8 HEX HEAD FULL THREAD ZINC	F81001-7	1	
37	GROMMET, 20/13 RUBBER	086188	1	
38	WASHER, 10.5 FLAT ZINC	F81055-1	4	
39	NUT, M20X1.5 THIN ZINC	F81037-7	2	

REF.	DESCRIPTION (◆ Indicates Parts Available In Assemblies Only)	PART#	QTY	
40	WASHER, Z 10.2 SPLIT LOCK ZINC	F81055-2	4	
41	BOLT, M10X35 8.8 HEX HEAD FULL THREAD ZINC	F81003-17	4	
42	SCREW, M10X1X20 DIN 913 STAINLESS STEEL SET	F81015-1	2	
43	GUARD, DEBARKER MOTOR	101332-1 ¹	1	
44	WASHER, 6.1 DIN 127 (A2-304) STAINLESS STEEL SPLIT LOCK	F81053-4 ¹	1	
45	BOLT, M6X20 8.8 HEX HEAD FULL THREAD ZINC	F81001-2	4	
-	GUARD ASSEMBLY	519064	1	
46	PLATE, GUARD	519061-1	1	
47	WASHER, 8.4 FLAT ZINC	F81054-1	2	
48	WASHER, 8.2 SPLIT LOCK ZINC	F81054-4	2	
49	BOLT, M8X16-8.8-B HEX HEAD FULL THREAD ZINC	F81002-20	2	
50	BUSHING, 9/13-40.5	519067-1	1	
51	WASHER, 8.2 SPLIT LOCK ZINC	F81054-4	1	
52	BOLT, M8X65 8.8 HEX HEAD FULL THREAD ZINC	F81002-9	1	
-	PIN ASSEMBLY, LOCKING	519066	1	
53	PIN, LOCKING	519065-1	1	
54	WASHER, 17 FLAT ZINC	F81058-1	1	
55	WASHER, 16.3 SPLIT LOCK ZINC	F81058-2	1	
56	NUT, M16-8 HEX ZINC	F81036-1	1	
57	CAP, 2.5 ID X 3 RUBBER	023720	1	

¹ Used on AC debarkers (525865) only

4.11 AC Debarker Blade Drive

096239_001
096239_MANUAL

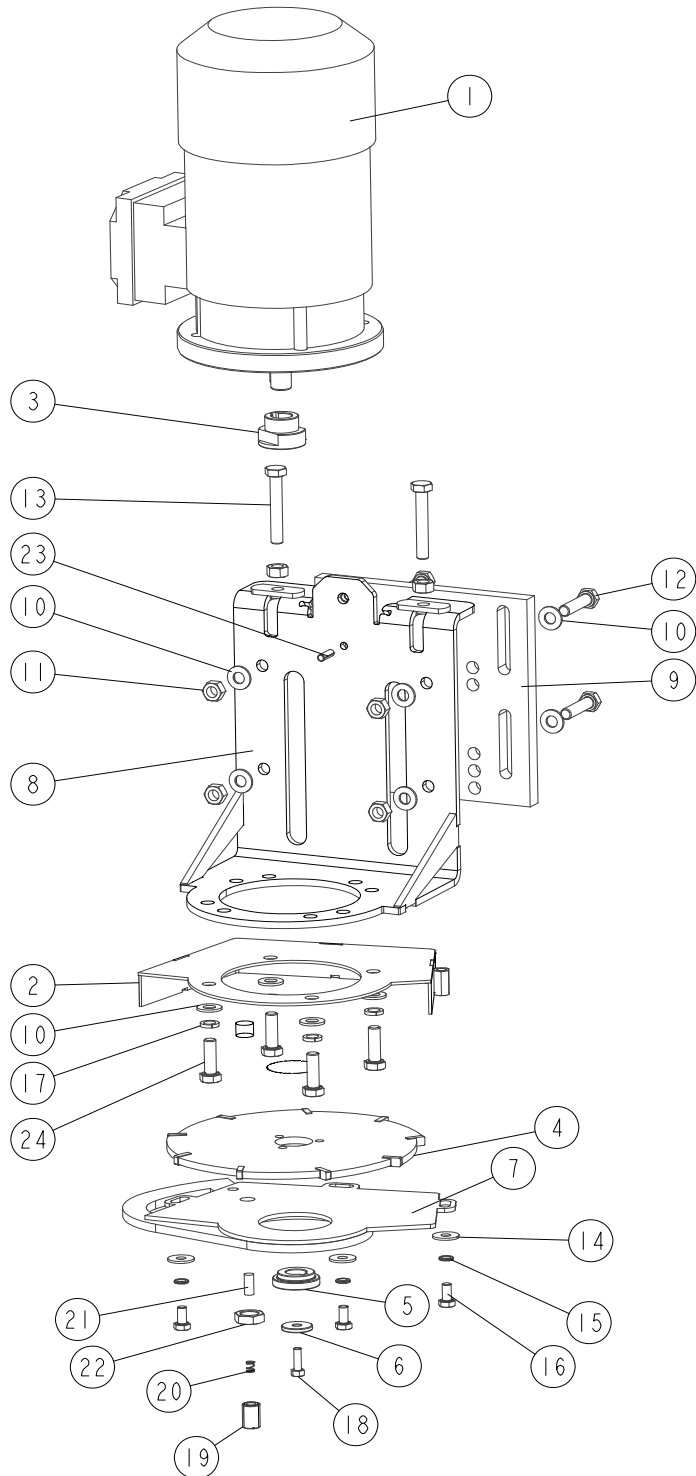

Debarker Parts

AC Debarker Blade Drive

4

REF.	DESCRIPTION (◆ Indicates Parts Available In Assemblies Only)	PART#	QTY	
-	DRIVE ASSEMBLY, AC DEBARKER BLADE	096239	1	
1	MOTOR, STKG71X-2C IMB5 AC DEBARKER	096777	1	
2	GUARD, DEBARKER BLADE UPPER	096244-1	1	
3	BUSHING, CLAMPING	096088	1	
4	BLADE, 180 B-06.5/5.0 D-25.5 - COMPLETE	083848-1	1	
5	BUSHING, RETAINING	096087	1	
6	WASHER	096238-1	1	
7	GUARD, DEBARKER BLADE LOWER	096245-1	1	
8	BRACKET, DEBARKER MOTOR MOUNT	096780-1	1	
9	PLATE, DEBARKER MOTOR MOUNT	089551	1	
10	WASHER, 8.4 FLAT ZINC	F81054-1	12	
11	NUT, M8-8-B HEX ZINC	F81032-1	6	
12	BOLT, M8X35-8.8 HEX HEAD FULL THREAD ZINC	F81002-13	4	
13	BOLT, M8X50-8.8 HEX HEAD FULL THREAD ZINC	F81002-19	2	
14	WASHER, 6.5 SPECIAL FLAT ZINC	F81053-11	3	
15	WASHER, Z 6.1 SPLIT LOCK ZINC	F81053-3	3	
16	BOLT, M6X12 8.8 HEX HEAD FULL THREAD ZINC	F81001-7	3	
17	WASHER, 8.2 SPLIT LOCK ZINC	F81054-4	4	
18	BOLT, M5X16 8.8 HEX HEAD FULL THREAD ZINC	F81000-20	1	
-	PIN ASSEMBLY, DEBARKER BLADE BRAKING	501464	1	
19	SCREW, M12X18 SET	501462	1	
20	SPRING, 0.5X5.5-7	501463	1	
21	PIN, DEBARKER BLADE BRAKING	501461	1	
22	NUT, M12-04-A THIN	F81034-6	1	
23	PIN, 5X16 ROLL ZINC	F81044-3	1	
24	BOLT, M8X25-8.8-B HEX HEAD FULL THREAD ZINC	F81002-5	4	

4.12 DC Debarker Blade Drive

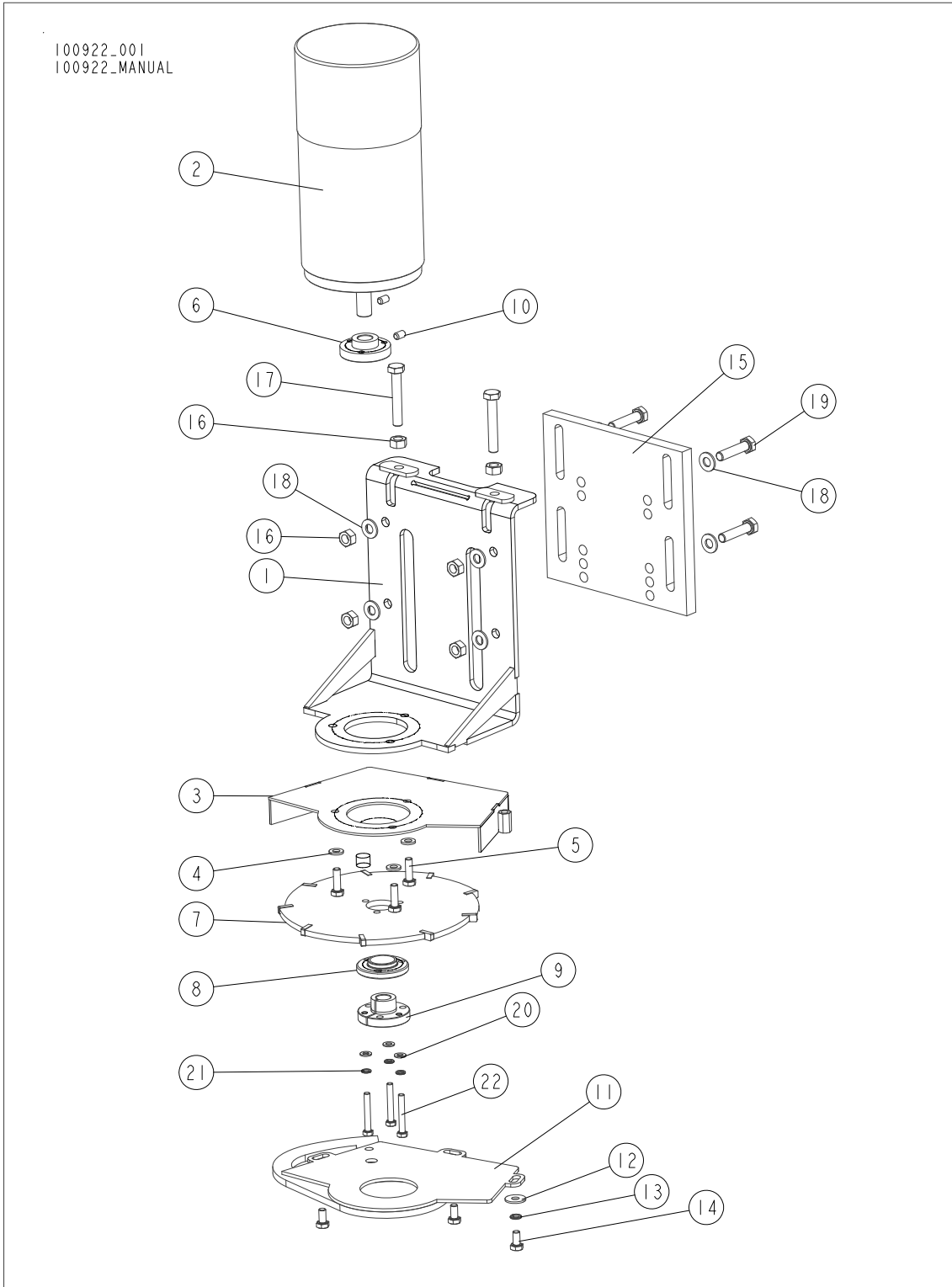

REF.	DESCRIPTION (◆ Indicates Parts Available In Assemblies Only)	PART#	QTY	
-	DRIVE ASSEMBLY, DC DEBARKER BLADE	100922	1	
1	BRACKET, DC DEBARKER MOTOR MOUNT	097493-1	1	
2	MOTOR, 0.75HP/1550 r.p.m. 12V DC	100918	1	
3	GUARD, DEBARKER BLADE UPPER	097499-1	1	
4	WASHER, 6.4 FLAT ZINC	F81053-1	3	
5	BOLT, M6X20 8.8 HEX HEAD FULL THREAD ZINC	F81001-2	3	
6	BUSHING, CLAMPING	097496	1	
7	BLADE, 180 B-06.5/5.0 D-25.5 - COMPLETE	083848-1	1	
8	BUSHING, MOUNTING	097495	1	
9	BUSHING, SPLIT TAPER	097494	1	
10	SCREW, M6X10-45H HEX SOCKET ZINC SET W/FLAT POINT	F81001-26	2	
11	GUARD, DEBARKER BLADE LOWER	096245-1	1	
12	WASHER, 6.5 SPECIAL FLAT ZINC	F81053-11	3	
13	WASHER, Z 6.1 SPLIT LOCK ZINC	F81053-3	3	
14	BOLT, M6X12 8.8 HEX HEAD FULL THREAD ZINC	F81001-7	3	
15	PLATE, DEBARKER MOTOR MOUNT	089551	1	
16	NUT, M8-8-B HEX ZINC	F81032-1	6	
17	BOLT, M8X50-8.8 HEX HEAD FULL THREAD ZINC	F81002-19	2	
18	WASHER, 8.4 FLAT ZINC	F81054-1	8	
19	BOLT, M8X35-8.8 HEX HEAD FULL THREAD ZINC	F81002-13	4	
20	WASHER, 5.3 FLAT ZINC	F81052-1	3	
21	WASHER, 5.1 SPLIT LOCK ZINC	F81052-2	3	
22	BOLT, M5X35 8.8 HEX HEAD FULL THREAD ZINC	F81000-10	3	