

Wood-Mizer[®] Sawmill

Parts Manual

LT40 Series DH

rev. C7.00



Safety is our #1 concern! Read and understand all safety information and instructions before operating, setting up or maintaining this machine.

February 1998

Form #536

Table of Contents

Section-Page

SECTION 1	GENERAL INFORMATION	1-1
1.1	How To Use The Parts List	1-1
1.2	Sample Assembly	1-1
SECTION 2	BLADE GUIDE ROLLERS & ARM	2-1
2.1	Blade Guide Assembly, Idle Side (Standard).....	2-1
2.2	Idle Side Blade Guide Assembly, Optional (LMS).....	2-3
2.3	Blade Guide Assembly, Drive Side.....	2-5
2.4	Blade Guide Arm Drive Assembly.....	2-7
SECTION 3	BLADE WHEELS & TENSIONER	3-1
3.1	Blade Drive Assembly.....	3-1
3.2	Idle Blade Wheel Assembly	3-3
3.3	Hydraulic Blade Tensioner Assembly.....	3-4
SECTION 4	SAW HEAD	4-1
4.1	Middle Throat Screw	4-1
4.2	Water Lube Solenoid Valve	4-2
4.3	Clutch Lever Assembly	4-3
4.4	Brake Assembly.....	4-5
4.5	Board Return Assembly	4-7
4.6	Water Lube Assembly	4-9
4.7	Saw Head Decals	4-11
4.8	Blade Housing Covers.....	4-13
4.9	Drive Belt Covers	4-15
4.10	Sawdust Chute	4-17
SECTION 5	CONTROL & BATTERY BOXES	5-1
5.1	Control Assembly, LT30HD/LT40HD Super	5-1
5.2	Drum Switches	5-3
5.3	Circuit Breakers.....	5-4
5.4	Solenoid Assemblies	5-5
5.5	Front Panel Assembly & Harnesses	5-6
5.6	Battery Box Assembly, LT30HD/LT40HD Super	5-7
5.7	Fuse Box Assembly, LT30HD/LT40HD Super	5-8
SECTION 6	UP/DOWN SYSTEM	6-1
6.1	Saw Head V-Brace Mount	6-1
6.2	Blade Height Scale	6-2
6.3	Up/Down Chain & Sprockets.....	6-4
6.4	Up/Down Motor Assembly, LT30HD/LT40HD Super	6-6

Table of Contents

Section-Page

6.5	Up/Down Drive Assembly, LT30HD/LT40HD Super	6-7	
SECTION 7	POWER FEED & TRACK ROLLERS		7-1
7.1	Upper Track Rollers And Wipers.....	7-1	
7.2	Power Feed Assembly, LT30HD/LT40HD Super	7-2	
7.3	Feed Chain/Stop, LT30HD/LT40HD Super	7-4	
7.4	Lower Track Rollers	7-6	
SECTION 8	BED FRAME ASSEMBLY		8-1
8.1	Bed Rail Assembly, Front And Rear	8-1	
8.2	Bed Rail Assembly, Front Middle	8-3	
8.3	Bed Rail Assembly, Rear Middle	8-4	
8.4	Leg, Stationary	8-6	
8.5	Board Return Table Assembly	8-8	
8.6	Pivot Bed Rail Assembly.....	8-10	
8.7	Log Side Support Assembly (Manual)	8-12	
8.8	Tie Down Chain Assembly	8-14	
8.9	Saw Head Rest Pin Assembly	8-15	
8.10	Bed Frame Decals	8-16	
SECTION 9	HYDRAULIC SYSTEM		9-1
9.1	Hydraulic Hoses	9-1	
9.2	Hydraulic Control Box	9-2	
9.3	Hydraulic Power Supply Strip.....	9-5	
9.4	Hydraulic Log Loader	9-7	
9.5	Hydraulic Log Turner	9-9	
9.6	Hydraulic Log Side Supports	9-11	
9.7	Hydraulic Log Clamp	9-13	
9.8	Hydraulic Toe Board	9-15	

SECTION 1 GENERAL INFORMATION

1.1 How To Use The Parts List

- Use the index above to locate the assembly that contains the part you need.
- Go to the appropriate section and locate the part in the illustration.
- Use the number pointing to the part to locate the correct part number and description in the table.
- Parts shown indented under another part are included with that part.
- Parts marked with a diamond (◆) are only available in the assembly listed above the part.

See the sample table below. Sample Part #A01111 includes part F02222-2 and subassembly A03333. Subassembly A03333 includes part S04444-4 and subassembly K05555. The diamond (◆) indicates that S04444-4 is not available except in subassembly A03333. Subassembly K05555 includes parts M06666 and F07777-77. The diamond (◆) indicates M06666 is not available except in subassembly K05555.

1.2 Sample Assembly				
REF	DESCRIPTION (◆ Indicates Parts Available In Assemblies Only)	PART #	QTY.	
	Sample Assembly, Complete (Includes All Indented Parts Below)	A01111	1	
1	Sample Part	F02222-22	1	
	Sample Subassembly (Includes All Indented Parts Below)	A03333	1	
2	Sample Part (◆ Indicates Part Is Only Available With A03333)	S04444-4	1	◆
	Sample Subassembly (Includes All Indented Parts Below)	K05555	1	
3	Sample Part (◆ Indicates Part Is Only Available With K05555)	M06666	2	◆
4	Sample Part	F07777-77	1	

To Order Parts:

- From Europe call our European Headquarters and Manufacturing Facility in Kolo, Poland at **+48-63-2626000**. From the continental U.S., call our toll-free Parts hotline at **1-800-448-7881**. Have your customer number, vehicle identification number, and part numbers ready when you call.
- From other international locations, contact the Wood-Mizer distributor in your area for parts.

SECTION 2 BLADE GUIDE ROLLERS & ARM

2.1 Blade Guide Assembly, Idle Side (Standard)

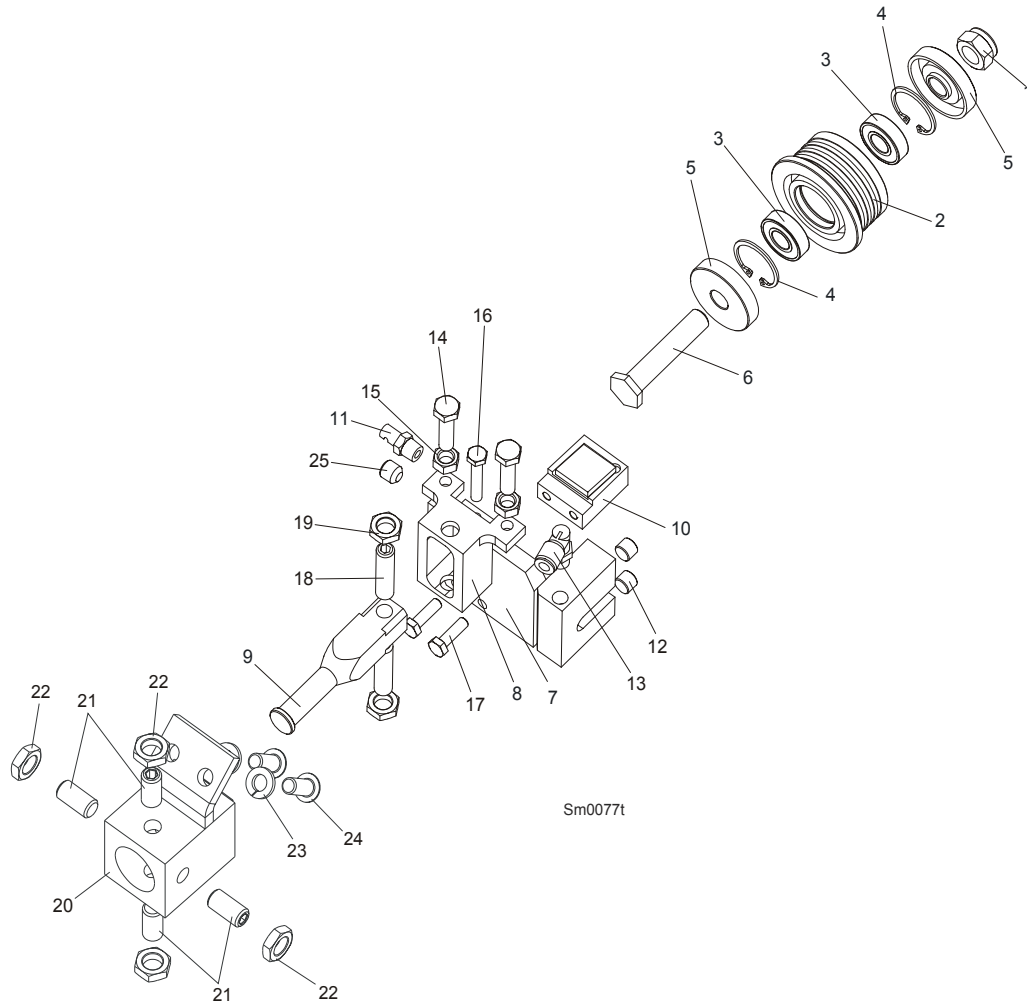

REF	DESCRIPTION (◆ Indicates Parts Available In Assemblies Only)	PART#	QTY.
	BLADE GUIDE ASSEMBLY, IDLE SIDE	092523	1
	Roller, Blade Guide Narrow W/Bearings	088261	1
1	Nut, M12-8 Hex Nylon Zinc Lock	F81034-2	1
2	Roller, Blade Guide Narrow	087889	1
3	Bearing, 6001 2RSR NACHI	087893	2
4	Ring, W28 Inside Retaining	F81090-9	2
5	Washer, Spacer	087891	2
6	Bolt, Blade Guide Roller Zinc-Plated	087761-1	1
7	Block Weldment, Nozzle Zinc-Plated	087750-1	1
8	Block, Zinc-Plated Roller Guide Adjuster	087756-1	1
9	Shaft, Zinc-Plated Blade Guide Mount	088255-1	1
10	Disc Assembly, EZ-Glide Blade Guide Wear	087760	1

2

Blade Guide Rollers & Arm

Blade Guide Assembly, Idle Side (Standard)

11	Nozzle, Blade Water Lube Spray	016637	1	
12	Plug, M10x1 DIN 906 BN40 "BOSSARD"	F81015-3	2	
13	Fitting, 90° Elbow 1/8NPT-1/4 Tube Swivel	P09736	1	
14	Bolt, M8x30 DIN933 A2-70 Stainless Steel	F81002-27	2	
15	Nut, M8 DIN934 A2-70 Stainless Steel	F81032-7	2	
16	Bolt, M6x35 DIN933 A2-70 Stainless Steel	F81001-37	1	
17	Bolt, M6x20-8.8 Hex Head Full Thread Zinc	F81001-2	2	
18	Screw, M10x1x40 DIN913 Stainless Steel Set	F81015-2	2	
19	Nut, M10x1 DIN439 Stainless Steel Thin	F81033-7	2	
20	BLOCK WELDMENT, PAINTED BLADE GUIDE MOUNT	088292-1	1	
21	SCREW, M10X1X20 DIN913 STAINLESS STEEL SET	F81015-1	4	
22	NUT, M10X1 DIN439 STAINLESS STEEL THIN	F81033-7	4	
23	WASHER, 8.2 SPLIT LOCK ZINC	F81054-4	2	
24	SCREW, 5/16-18X3/4 BLACK OXIDE SOCKET BUTTON HEAD	F05006-7	2	
25	FITTING, 1/8 NPT SOCKET PIPE PLUG	P30127	1	

2.2 Idle Side Blade Guide Assembly, Optional (LMS)

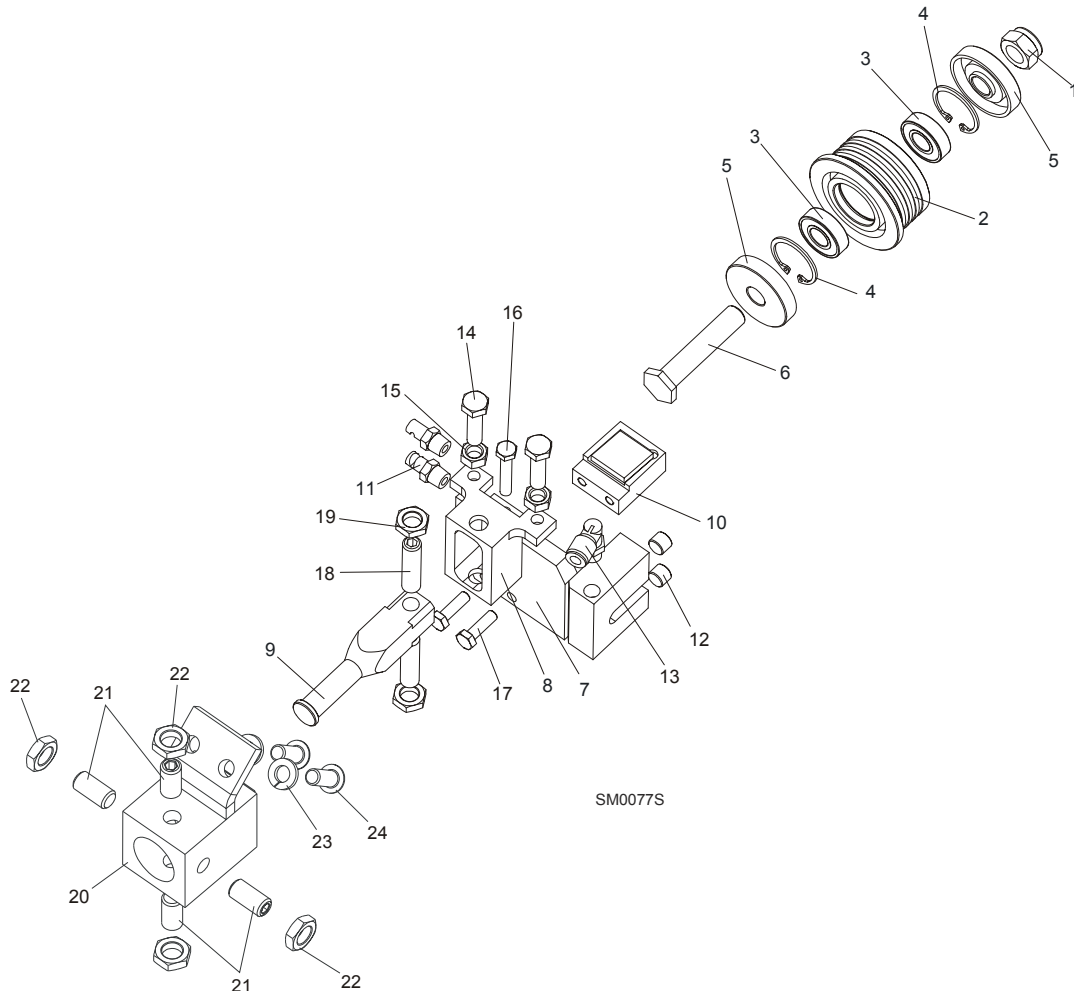

REF	DESCRIPTION (◆ Indicates Parts Available In Assemblies Only)	PART#	QTY.
	BLADE GUIDE ASSEMBLY, IDLE SIDE	087749	1
	Roller, Blade Guide Narrow W/Bearings	088261	1
1	Nut, M12-8 Hex Nylon Zinc Lock	F81034-2	1
2	Roller, Blade Guide Narrow	087889	1
3	Bearing, 6001 2RSR NACHI	087893	2
4	Ring, W28 Inside Retaining	F81090-9	2
5	Washer, Spacer	087891	2
6	Bolt, Blade Guide Roller Zinc-Plated	087761-1	1
7	Block Weldment, Nozzle Zinc-Plated	087750-1	1
8	Block, Zinc-Plated Roller Guide Adjuster	087756-1	1
9	Shaft, Zinc-Plated Blade Guide Mount	088255-1	1
10	Disc Assembly, EZ-Glide Blade Guide Wear	087760	1
11	Nozzle, Blade Lube Spray	033479	2

2

Blade Guide Rollers & Arm

Idle Side Blade Guide Assembly, Optional (LMS)

12	Plug, M10x1 DIN 906 BN40 "BOSSARD"	F81015-3	2	
13	Fitting, 90° Elbow 1/8NPT-1/4 Tube Swivel	P09736	1	
14	Bolt, M8x30 DIN933 A2-70 Stainless Steel	F81002-27	2	
15	Nut, M8 DIN934 A2-70 Stainless Steel	F81032-7	2	
16	Bolt, M6x35 DIN933 A2-70 Stainless Steel	F81001-37	1	
17	Bolt, M6x20-8.8 Hex Head Full Thread Zinc	F81001-2	2	
18	Screw, M10x1x40 DIN913 Stainless Steel Set	F81015-2	2	
19	Nut, M10x1 DIN439 Stainless Steel Thin	F81033-7	2	
20	BLOCK WELDMENT, PAINTED BLADE GUIDE MOUNT	088292-1	1	
21	SCREW, M10X1X20 DIN913 STAINLESS STEEL SET	F81015-1	4	
22	NUT, M10X1 DIN439 STAINLESS STEEL THIN	F81033-7	4	
23	WASHER, 8.2 SPLIT LOCK ZINC	F81054-4	2	
24	SCREW, 5/16-18X3/4 BLACK OXIDE SOCKET BUTTON HEAD	F05006-7	2	

2.3 Blade Guide Assembly, Drive Side

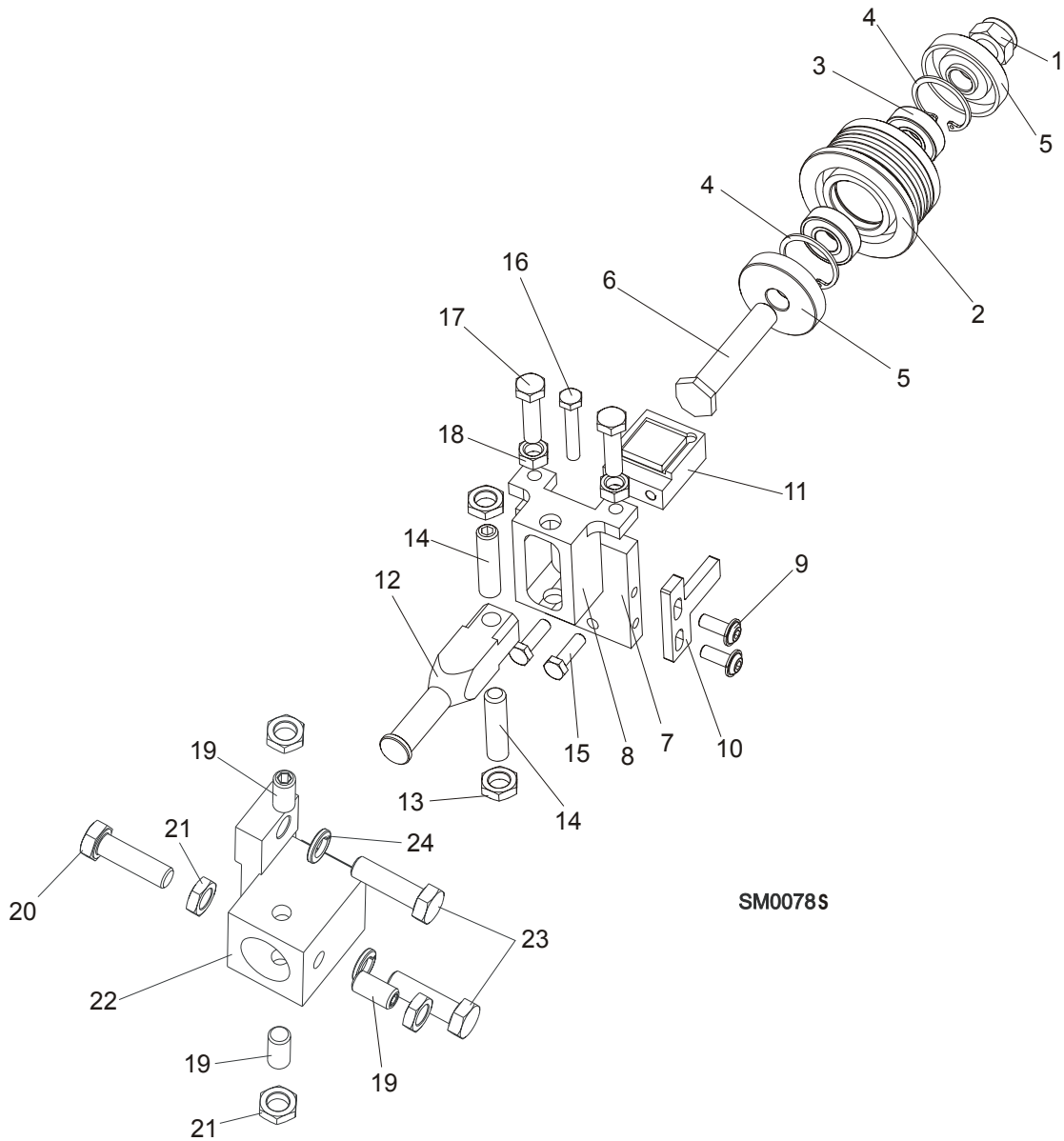

REF	DESCRIPTION (◆ Indicates Parts Available In Assemblies Only)	PART#	QTY.
	BLADE GUIDE ASSEMBLY, DRIVE SIDE	087748	1
	Roller, Blade Guide Narrow W/Bearings	088261	1
1	Nut, M12-8 Hex Nylon Zinc Lock	F81034-2	1
2	Roller, Blade Guide Narrow	087889	1
3	Bearing, 6001 2RSR NACHI	087893	2
4	Ring, W28 Inside Retaining	F81090-9	1
5	Washer, Spacer	087891	2
6	Bolt, Blade Guide Roller Zinc-Plated	087761-1	1

2

Blade Guide Rollers & Arm

Blade Guide Assembly, Drive Side

7	Plate, Zinc-Plated Blade Guide Mounting	087753-1	1	
8	Block, Zinc-Plated Roller Guide Adjuster	087756-1	1	
9	Screw, M6x16 BN 11252 "BOSSARD"	F81001-24	2	
10	Wiper, Blade Zinc-Plated	087757-1	1	
11	Disc Assembly, EZ-Glide Blade Guide Wear	087760	1	
12	Shaft, Zinc-Plated Blade Guide Mount	088255-1	1	
13	Nut, M10x1 DIN439 Stainless Steel Thin	F81033-7	2	
14	Screw, M10x1x40 DIN913 Stainless Steel Set	F81015-2	2	
15	Bolt, M6x20-8.8 Hex Head Full Thread Zinc	F81001-2	2	
16	Bolt, M6x35 DIN933 A2-70 Stainless Steel	F81001-37	1	
17	Bolt, M8x30 DIN933 A2-70 Stainless Steel	F81002-27	2	
18	Nut, M8 DIN934 A2-70 Stainless Steel	F81032-7	2	
19	Screw, M10X1X20 DIN913 Stainless Steel Set	F81015-1	3	
20	BOLT, M10X1X25 DIN 933 STAINLESS STEEL	F81003-28	1	
21	NUT, M10X1 DIN439 STAINLESS STEEL THIN	F81033-7	4	
22	BLOCK WELDMENT, BLADE GUIDE MOUNT	087744	1	
23	BOLT, M10X35-8.8 HEX HEAD FULL THREAD ZINC	F81003-17	2	
24	WASHER, 10.2 SPLIT LOCK ZINC	F81055-2	2	

2.4 Blade Guide Arm Drive Assembly

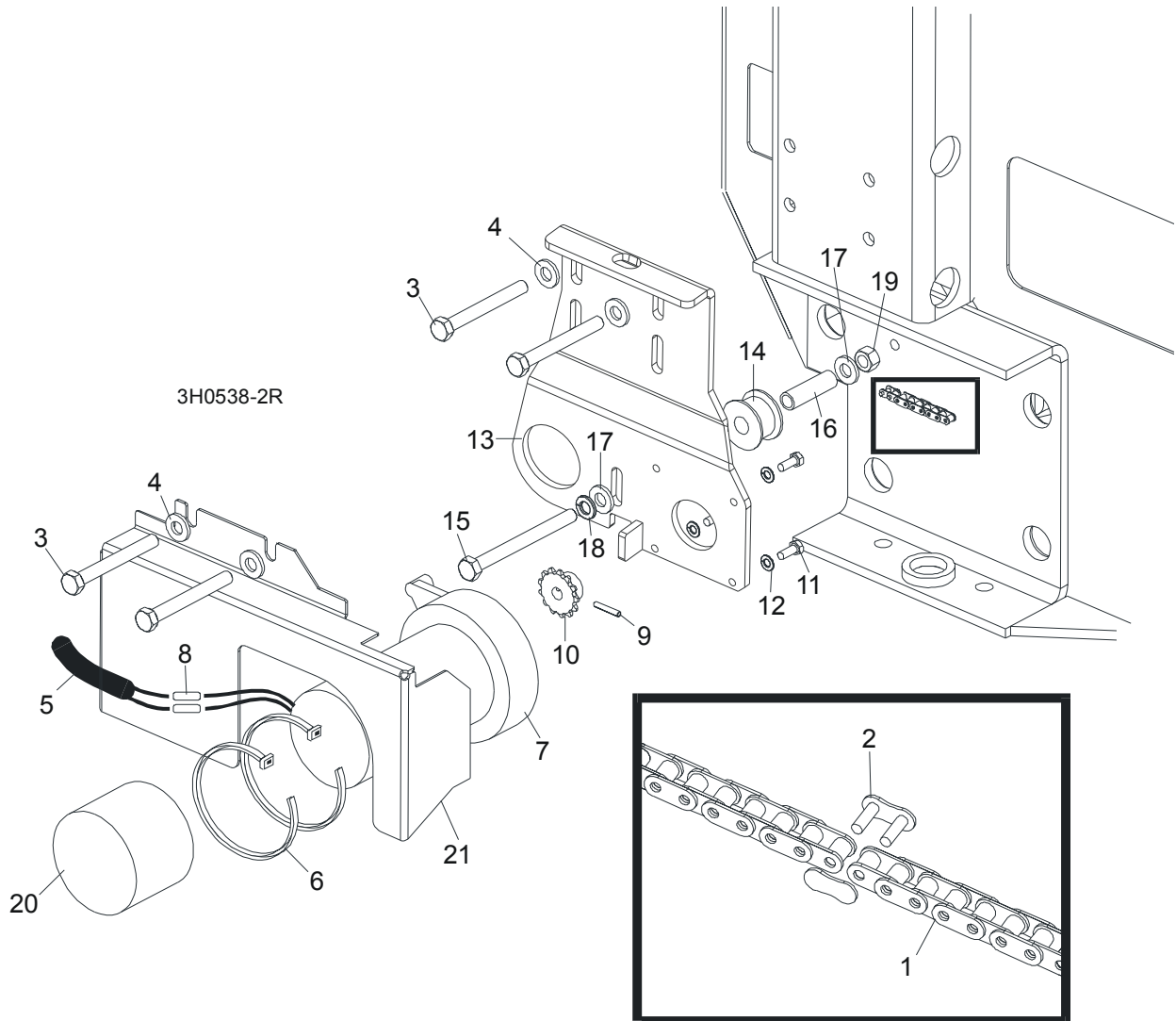

REF	DESCRIPTION (◆ Indicates Parts Available In Assemblies Only)	PART #	QTY.
1	CHAIN, #25 X 20 1/4"	P09984	1
2	LINK, #25 MASTER	P09983	1
3	BOLT, 5/16-18 X 2 3/4" HEX HEAD GRADE 5	F05006-28	4
4	WASHER, 8.4 FLAT	F81054-1	4
5	TUBE, 3/8" X 1/2" NEOPRENE	R01897	0,75 m
6	WRAP, 1/4" X 6" TIE	F05089-1	2
	DRIVE ASSEMBLY, BLADE GUIDE ARM	091005	1
	Motor Assembly, Blade Guide Arm Replacement	A10365	1
7	Motor, Blade Guide Arm 53:1 Gear	P09698-1	1
	Housing, Klauber Motor End	P12756	1
	Gear Kit, Klauber Motor Replacement	P12569	1

2

Blade Guide Rollers & Arm

Blade Guide Arm Drive Assembly

	Brush Kit, Gear Motor Replacement	P12800	1	
	Shaft Kit, Klauber Gear Motor Replacement	009695	1	
8	Connector, 14 Gauge Butt	F04875-1	2	
9	Pin, 1/8" X 3/4" Roll	F05012-6	1	
10	Sprocket, Gear Motor #25 14-Tooth	P09970	1	
11	Screw, #10-32 x 1/2" Hex Head	F05004-60	4	
12	Washer, 5.1 Split Lock	F81052-2	4	
	Instruction Sheet, Blade Guide Arm Motor	A10353-296	1	
13	Bracket, Blade Guide Arm Motor Mount	087994-1	1	
14	Roller, Blade Guide Arm Chain Idler	S09999	1	
15	Bolt, M8x90-8.8 Hex Head Full Thread	F81002-16	1	
16	Spacer, 5/16" I.D. X 1 1/2"	S09996	1	
17	Washer, 5/16" SAE Flat	F81054-1	3	
18	Washer, 8.2 Split Lock	F05011-13	1	
19	Nut, M8-8-B Hex Lock	F81032-1	1	
20	Boot, Gear Motor Weather	023720	1	
21	COVER, BLADE GUIDE ARM MOTOR	S11617	1	

SECTION 3 BLADE WHEELS & TENSIONER

3.1 Blade Drive Assembly

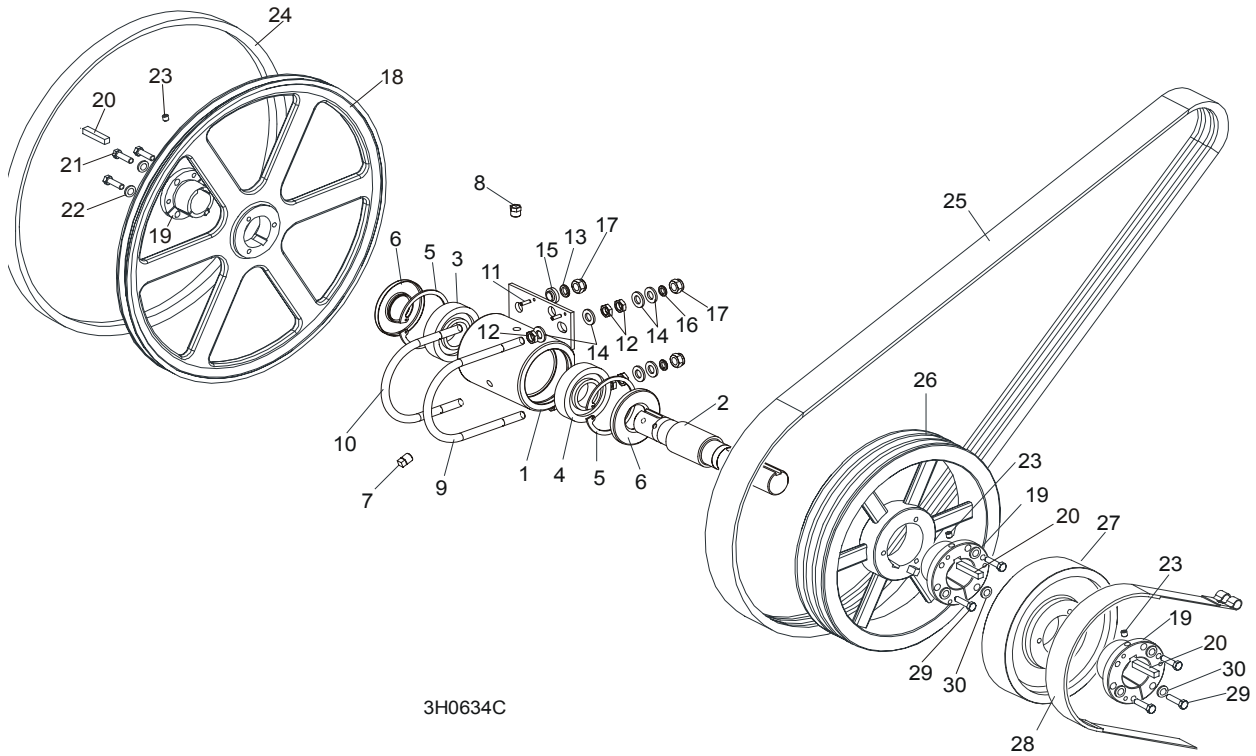

REF	DESCRIPTION (◆ Indicates Parts Available In Assemblies Only)	PART #	QTY.
	BEARING ASSEMBLY, DRIVE	086291	1
1	Housing, Blade Wheel Drive Bearing	086293	1
2	Shaft, Blade Wheel Drive	086292	1
3	Bearing, Blade Wheel Drive NJ308	085939	1
4	Bearing, Blade Wheel Drive #6308	085940	1
5	Ring, 90mm Interior Retaining #17	F04254-17	2
6	Seal, Drive Bearing #CR15890	P10206	2
7	Plug, 1/4" NPT Square Head	P05498	1
8	Plug, 1/4" NPT Vented	P12868	1
9	Bolt, 1/2-13 Long U	S10207-1P	1
10	Bolt, 1/2-13 Short U	S10207-2P	1
11	Pin, 3/16" X 5/8" Roll	F05012-22	2
12	Nut, M12-04-A Hex Jam	F81034-6	6
13	Washer, 12.2 Split Lock	F81056-2	2
14	Washer, 13 SAE Flat	F81056-1	8
15	Spacer, Zinc	086769-1	2
16	Washer, 10.2 Split Lock Zinc	F81055-2	2

3

Blade Wheels & Tensioner

Blade Drive Assembly

17	Nut, M12-8 Hex Nylon Lock	F81034-2	4	
	WHEEL KIT, DRIVE SIDE BLADE	014562	1	
18	Wheel, Drive Side Blade	016284	1	
19	Bushing, Modified 1 9/16" P1	087214	1	
20	KEY, 9.5h7x9.5x3.8	087384	3	
21	BOLT, UNC 1/4"x1 1/2"-8.8 ZINC DIN933 HEX HEAD	F05005-31	3	
22	WASHER, 1/4" UNC ZINC SPLIT LOCK	F81052-21	3	
23	SCREW, M8x8-33H ZINC HEX SOCKET SET FLAT POINT	F81014-1	3	
24	BELT, BLADE WHEEL B57	P04185	1	
25	BELT, 3BX72 DRIVE (D40)	014085	1	
	BELT, 3BX74 DRIVE E25HP 50HZ)	014249	1	
26	PULLEY, 3B5V124 SPECIAL DRIVE	087203-1	1	
27	WHEEL, BRAKE	087204-1	1	
28	STRAP, METAL-BACKED BRAKE	014391	1	
29	BOLT, M8X35-8.8 ZINC HEX HEAD FULL THREAD	F81002-13	6	
30	WASHER, 8.2 ZINC SPLIT LOCK	F81054-4	6	

3.2 Idle Blade Wheel Assembly

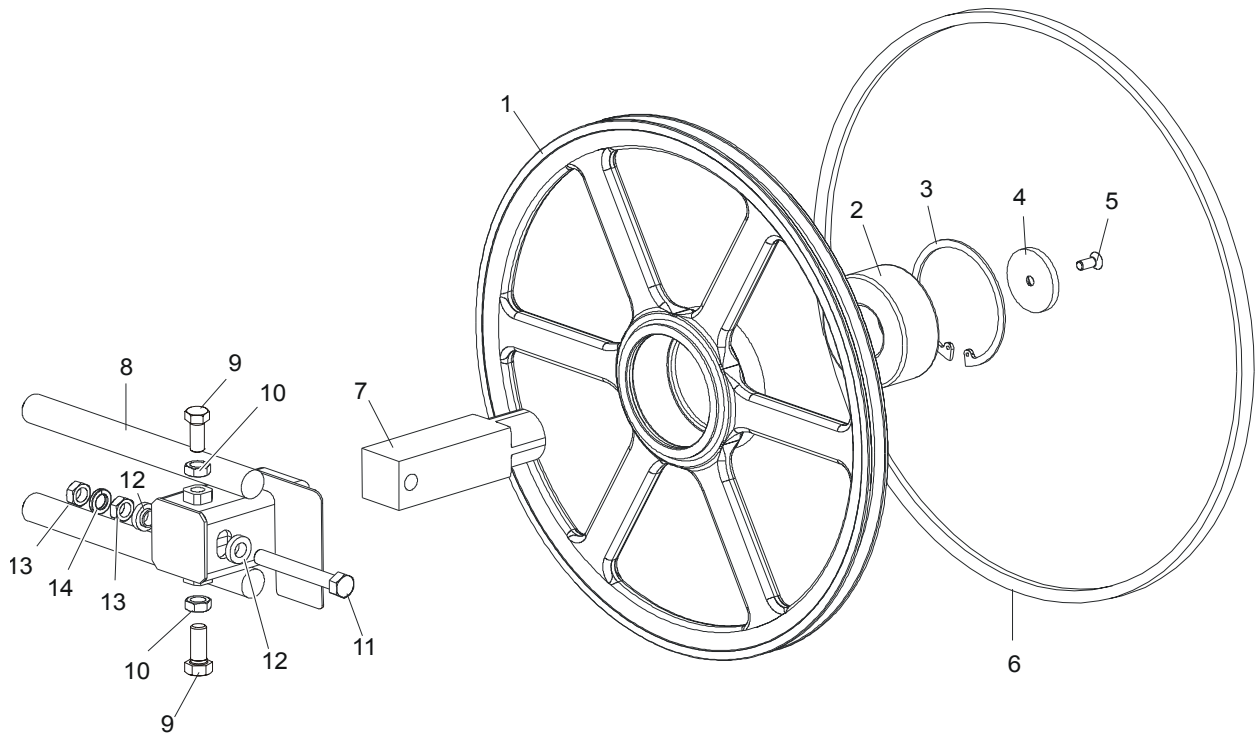

SM0241C

REF	DESCRIPTION (◆ Indicates Parts Available In Assemblies Only)	PART #	QTY.	
	WHEEL ASSEMBLY, IDLE SIDE BLADE	016120	1	
1	Wheel, Idle Side Blade	016013	1	◆
2	Bearing, Idle Side Blade Wheel #5309-2RS, C3, SRI-2 Grease	086428	1	
3	Ring, 100mm Internal Retaining Beveled	F04254-28	1	
4	RETAINER, 2 3/16 X 1/4"	016397	1	
5	SCREW, 3/8-16X1	F05007-64	1	
6	BELT, BLADE WHEEL B57	P04185	1	
7	SHAFT, IDLE BLADE WHEEL	016398	1	
8	HOUSING, IDLE BLADE WHEEL SHAFT	087665	1	
9	SCREW, 1/2-20 X 1 1/4" FLAT POINT SET	F05008-108	2	
10	NUT, 1/2-20 HEX JAM	F05010-16	2	
11	BOLT, 1/2-20 X 3 3/4" HEX HEAD FULL THREAD GRADE 2	F05008-111	1	
12	SPACER, 1/2" I.D. FLANGED	086769-1	2	
13	NUT, 1/2-20 HEX JAM	F05010-16	2	
14	WASHER, 12.2 SPLIT LOCK	F81056-2	1	

3

Blade Wheels & Tensioner Hydraulic Blade Tensioner Assembly

3.3 Hydraulic Blade Tensioner Assembly

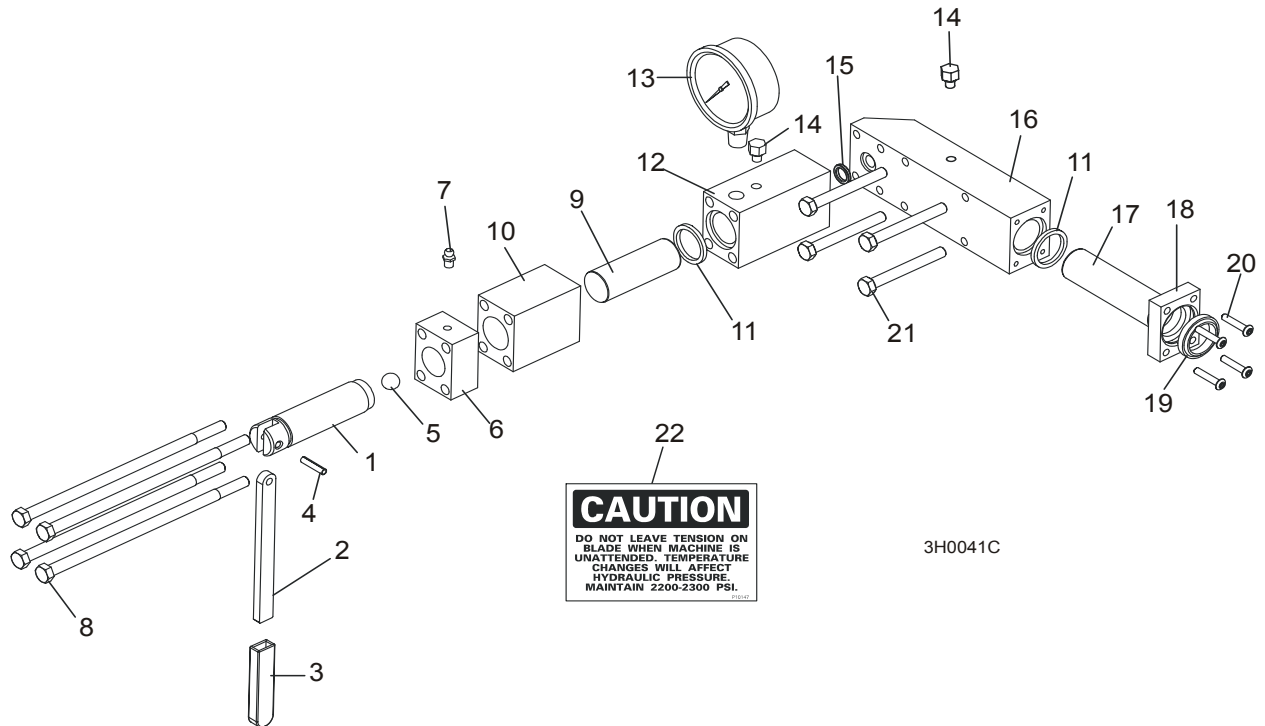

CAUTION
DO NOT LEAVE TENSION ON
BLADE WHEN MACHINE IS
UNATTENDED. TEMPERATURE
CHANGES WILL AFFECT
HYDRAULIC PRESSURE.
MAINTAIN 2200-2300 PSI.

3H0041C

REF	DESCRIPTION (◆ Indicates Parts Available In Assemblies Only)	PART #	QTY.
	HYDRAULIC BLADE TENSIONER ASSEMBLY	A10054	1
	Handle Assembly, Hydraulic Blade Tensioner Screw	A12294	1
1	Screw, Hydraulic Blade Tensioner	S10056	1
2	Handle, Hydraulic Tensioner Screw	S08174	1
3	Sleeve, Plastic Handle	P08072	1
4	Pin, 3/16" x 7/8" Roll	F05012-11	1
5	Ball, 1/2" Steel	P02720	1
6	Block, Threaded Tensioner End	S10062	1
7	Fitting, 1/4-28 Grease	P05060	1
	Instruction Sheet, Tensioner Screw	A12294-518	1
8	Bolt, 5/16-18 X 7 1/2" Hex Head Grade 5	F05006-43	4
9	Piston, Hydraulic Tensioner Front 2 3/4" Long	S10060	1
10	Block, Piston Guide	S10061	1
11	Seal, 1" Diameter	P10051	2
12	Block, Hydraulic Tensioner Gauge Mounting	S10140	1
13	Gauge, 3000 PSI	090552	1
14	Plug, Hydraulic Tensioner Fill	P10065	2
15	Ring, 5/8" X 3/32" Square "O"	P10377	1
16	Block, Rear Tensioner Piston	S10142	1
17	Piston, Hydraulic Tensioner Rear 3 5/8" Long	S10059	1
18	Block, Rear Piston End	S10089	1
19	Wiper, 1" Diameter	P10053	1
20	Bolt, #10-24 X 1" Socket Button Head	F05004-43	4

21	Bolt, 5/16-18 X 2 3/4" Hex Head Grade 5	F05006-28	4	
22	Decal, Hydraulic Tension Caution	P10147	1	
	Instruction Sheet, Hydraulic Tensioner Installation	A10136-272	1	

4 Saw Head
Middle Throat Screw

SECTION 4 SAW HEAD

4.1 Middle Throat Screw

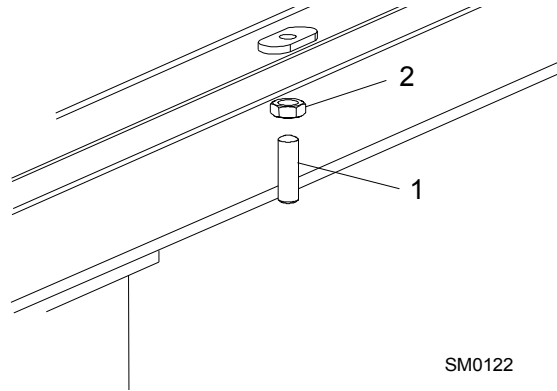

REF	DESCRIPTION (◆ Indicates Parts Available In Assemblies Only)	PART #	QTY.	
1	SCREW, M10X40-45H OVAL POINT SOCKET SET, ZINC	F81003-61	1	
2	NUT, M10-8-B HEX JAM, ZINC	F81033-3	1	

4.2 Water Lube Solenoid Valve

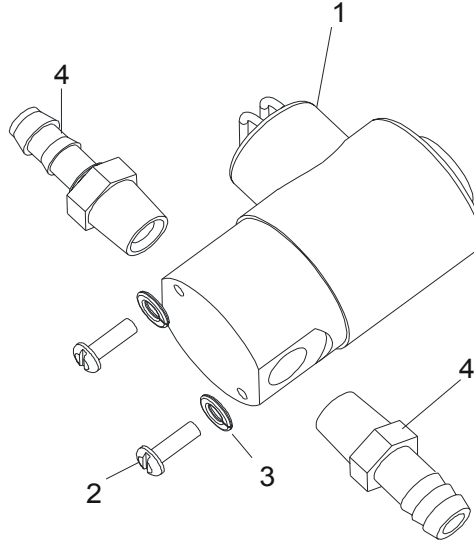

3H0310B

REF	DESCRIPTION (◆ Indicates Parts Available In Assemblies Only)	PART #	QTY.	
1	VALVE, WATER LUBE SOLENOID	016140	1	
2	SCREW, #10-32X1/2" CROSS SLOT ROUND HEAD	F05004-60	2	
3	WASHER, 5.1 SPLIT LOCK	F81052-2	2	
4	FITTING, 1/4" MALE NPT 3/8" HOSE BARB	P04682	2	

4.3 Clutch Lever Assembly

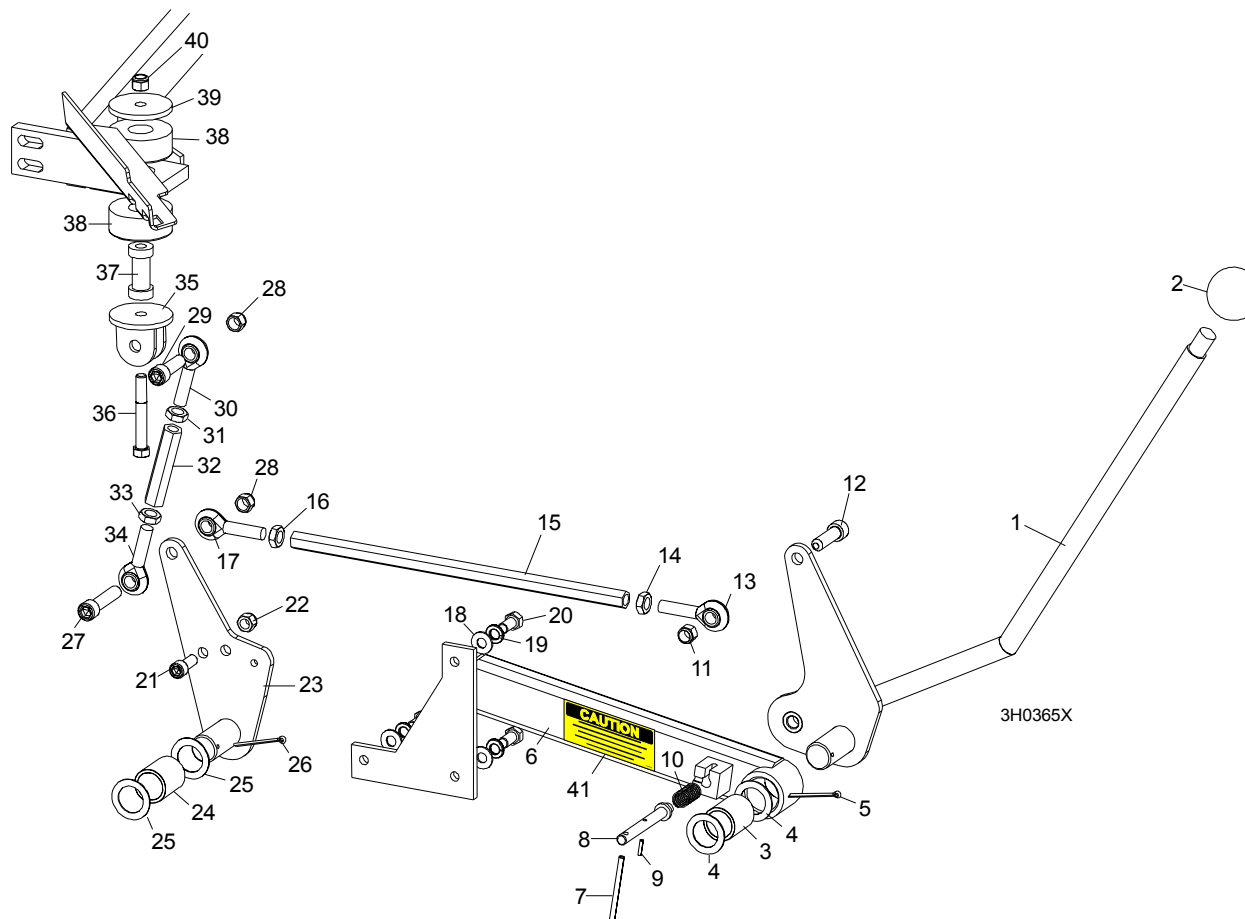

REF	DESCRIPTION (◆ Indicates Parts Available In Assemblies Only)	PART #	QTY.	
	HANDLE ASSEMBLY, EXTENDED CLUTCH/BRAKE	086242	1	
1	Lever, Clutch/Brake	086339-1	1	◆
2	Knob, Plastic Round	086337	1	
3	Bushing, Clutch/Brake Pivot	P05041	1	
4	Washer, Clutch/Brake Pivot	087051-1	2	
5	Pin, 1/8" X 1 3/4" Cotter	F05012-43	1	
6	Extension Weldment, Clutch Handle	086244-1	1	
7	Pin, 3/16 x 2 1/2" Roll	F05012-27	1	
8	Pin, Clutch Detent	086243 ¹	1	◆
9	Pin, 1/8" x 9/16" Roll	F05012-30	1	
10	Spring, .58" OD x 1 1/8"	021243	1	
11	Nut, 7/16-20 Nylon Lock	F05010-83	1	
12	Screw, 7/16-20 x 1 1/2" Socket Head	F05007-55	1	
13	Rod End, 7/16-20 Left Hand Thread	P11578	1	
14	Nut, 7/16-20 Hex Jam Left Hand Thread	F05010-87	1	
15	Rod, Clutch Extension	015073	1	
16	Nut, 7/16-20 Hex Jam	F05010-38	1	

17	Rod End, 7/16-20 Right Hand Thread	P11579	1	
18	WASHER, 8.4 SAE FLAT	F81054-1	3	
19	WASHER, 8.2 SPLIT LOCK	F81054-4	3	
20	BOLT, M8X20-8.8-B HEX HEAD	F81002-4	3	
21	BOLT, M10 X 25 SOCKET HEAD	F81003-32	1	
22	NUT, M10-8-B HEX NYLON LOCK	F81033-1	1	
23	PLATE WELDMENT, CLUTCH PIVOT	087086-1	1	
24	BUSHING, CLUTCH/BRAKE PIVOT	P05041	1	
25	WASHER, CLUTCH/BRAKE PIVOT	087051-1	2	
26	PIN, 1/8" X 1 3/4" COTTER	F05012-43	1	
27	SCREW, 7/16-20 X 2" SOCKET HEAD	F05007-120	1	
28	NUT, 7/16-20 HEX NYLON LOCK	F05010-83	2	
29	SCREW, 7/16-20 X 2" SOCKET HEAD	F05007-120	1	
	TURNBUCKLE ASSEMBLY, CLUTCH/BRAKE LEVER	A12304	1	
	TURNBUCKLE ASSEMBLY, 3 3/4" CLUTCH/BRAKE LEVER (50Hz Electric Only)	A11576	1	
30	Rod End, 7/16-20 Right Hand Thread	P11579	1	
31	Nut, 7/16-20 Hex Jam	F05010-38	1	
32	Turnbuckle, 3" Clutch/Brake Lever	S11577	1	
	Turnbuckle, 3 3/4" Clutch/Brake Lever (50Hz Electric Only)	S12262	1	
33	Nut, 7/16-20 Hex Jam Left Hand Thread	F05010-87	1	
34	Rod End, 7/16-20 Left Hand Thread	P11578	1	
35	BRACKET, CLUTCH MOUNT	W12411-1	1	
36	BOLT, M10X70-8.8 HEX HEAD, ZINC	F81003-20	1	
37	SPACER, MOTOR MOUNT VIBRATION BUSHING	S12410	1	
38	BUSHING, MOTOR MOUNT VIBRATION	P05032	2	
39	WASHER, 3/8" I.D. X 2 1/4" O.D. X 3/16" THICK	S12412-0	1	
40	NUT, 3/8-16 NYLON LOCK	F05010-10	1	
41	DECAL, PLACE PIN IN DETENT POSITION	085089	1	

¹ Detent pin removed . Detent pin should be removed from previous revision mills to prevent possible injury caused by unintended use of the detent pin (such as using the pin to enable the blade to be spun by hand during blade tracking). See bulletin #970053LR for pin removal instructions.

4 Saw Head

Brake Assembly

4.4 Brake Assembly

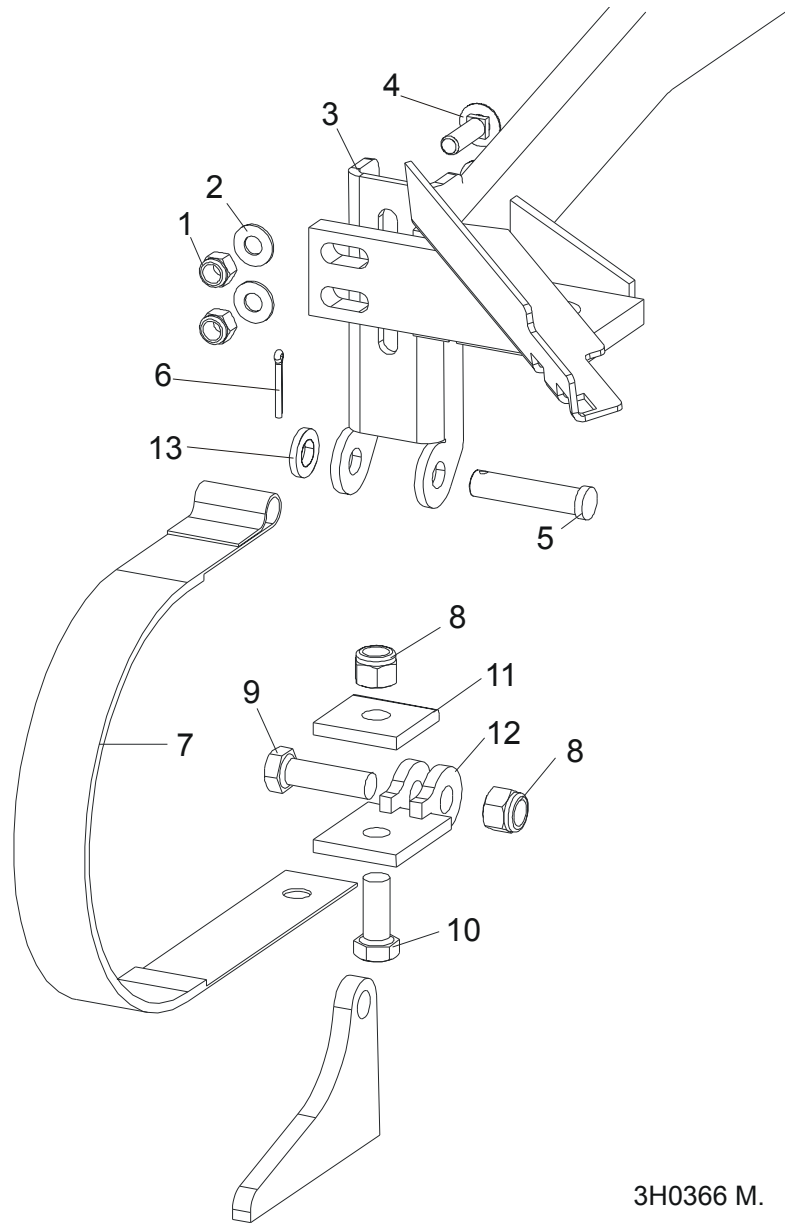

3H0366 M.

REF	DESCRIPTION (◆ Indicates Parts Available In Assemblies Only)	PART #	QTY.	
	STRAP RETROFIT, SUPER BRAKE	014441	1	
1	Nut, 3/8-16 Nylon Lock	F05010-10	2	
2	Washer, 10.5 Flat	F81055-1	2	
3	Bracket, Upper Super Brake Strap Mount	014395	1	
4	Bolt, 3/8-16 x 1 1/4" Carriage Head Grade 5	F05007-127	2	
5	Pin, 1/2" x 2 1/4" Clevis	F05012-81	1	
6	Pin, 1/8" x 1" Cotter	F05012-1	1	
7	Strap, Upper Pivot Metal Brake	014391	1	
8	Nut, M12-8-B Nylon Lock	F81034-2	2	

9	Bolt, M12 x 40-8.8 Hex Head	F81004-4	1	
10	Bolt, M12 x 30-8.8 Hex Head	F81004-22	1	
11	Plate, Brake Strap Clamp	S04195-1	1	
12	Bracket, Lower Super Brake Strap Mount	014392	1	
13	Washer, 13 Flat Zinc	F81056-1	1	

4 Saw Head Board Return Assembly

4.5 Board Return Assembly

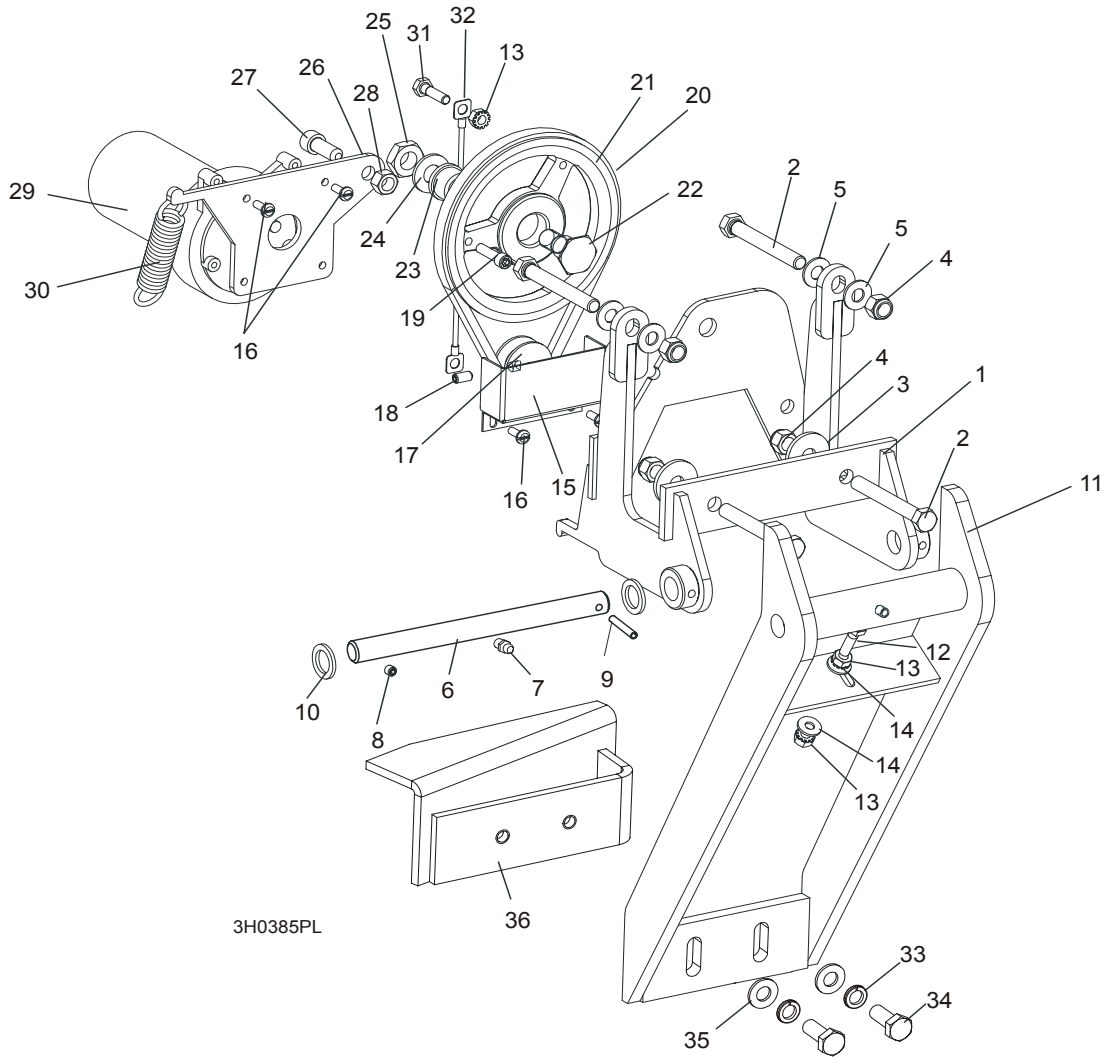

REF	DESCRIPTION (◆ Indicates Parts Available In Assemblies Only)	PART #	QTY.
	RETURN ASSEMBLY, BOARD	087839-1	1
1	Mount Weldment, Board Return	087788-1	1
2	Bolt, 3/8-16 x 3" Full Thread Hex Head	F05007-1	4
3	Washer, 1/8" x 1 1/4"	015336	2
4	Nut, 3/8-16 Hex Nylon Lock	F05010-10	4
5	Washer, 10.5 Flat	F81055-1	4
6	Pin Kit, Board Return Replacement Pivot	087837	1
7	Fitting, M6 Grease	086280	1
8	Screw, M6 X 8 Black Oxide Socket Head Set Cup Point	F81013-1	1
9	Pin, 5 X 30 Roll	F81044-21	1
10	Washer, 5/8" x 15/16" x .094 Nylon	F05011-19	2
11	Arm Weldment, Board Return	087838-1	1

12	Screw, 1/4-20 x 1" Full Thread Hex Head Cap	F05005-101	1	
13	Nut, 1/4-20 Self Locking	F05010-9	3	
14	Washer, 7.4 Flat	F81056-11	2	
15	Guard, Board Return Belt	015007	1	
16	Screw, 10-32 x 1/2" Hex Head Machine	F05004-55	4	
17	Sheave, 1.42 x .32	015074	1	
18	Screw, 1/4-20 Socket Head Set Cup Point Nylon	F05005-55	1	
19	Screw, 1/4-20 x 1" Socket Head Cap	F05005-89	1	
20	Belt, 3L190	015477	1	
21	Sheave, OK50 x 1/2" Modified	015224	1	
22	Bolt, Idler Pulley Pivot	015221	1	
23	Bushing, 5/8" x 7/8" x 1/2" Bronze	P05135	1	
24	Washer, 13 Flat	F81056-1	1	
25	Nut, 1/2-20 Jam Nylon Lock	F05010-79	1	
26	Plate, Motor Pivot	087871	1	
27	Screw, M10 x 25-8.8 Black Oxide Socket Head Cap	F81003-32	1	
28	Nut, 3/8-16 Self Locking	F05010-25	1	
29	Motor, 53:1 ASA Gear	P09698-1	1	
30	Spring, 3/4" x 2 7/8" x 12 Gauge	015479	1	
31	Bolt, 1/4-20 x 1" Hex Head Grade 5	F05005-101	1	
32	Cable, Board Return	016090	1	
33	Washer, 10.2 Split	F81055-2	2	
34	Bolt, 3/8-16 x 3/4" Hex Head	F81003-1	2	
35	Washer, 10.5 Flat	F81055-1	2	
36	Angle, Board Return	087835-1	1	

4 Saw Head
Water Lube Assembly

4.6 Water Lube Assembly

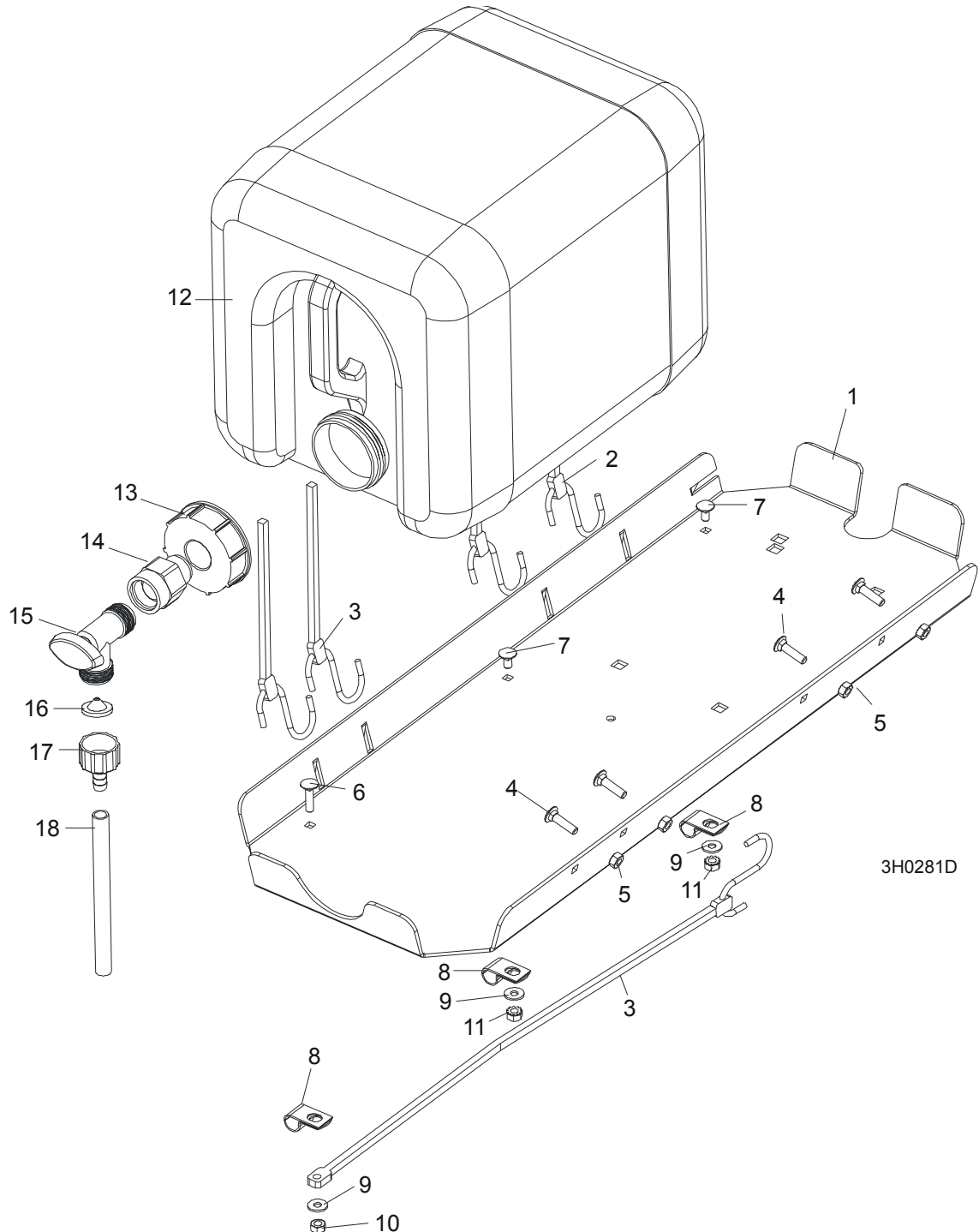

REF	DESCRIPTION (◆ Indicates Parts Available In Assemblies Only)	PART #	QTY.	
	TRAY ASSEMBLY, FUEL TANK/WATER BOTTLE	A11685	1	
1	Tray, Fuel Tank/Water Bottle	090376-1	1	◆

2	Strap, 24" Rubber (For Fuel Tank - See Engine Manual)	P11258	2	
3	Strap, 20" Rubber	P11668	3	
4	Bolt, 1/4-20 X 1" Carriage Head	F05005-34	4	
5	Nut, 1/4-20 Hex Lock	F05010-21	4	
6	BOLT, 1/4-20 X 1" CARRIAGE HEAD	F05005-34	1	
7	BOLT, 1/4-20 X 1/2" CARRIAGE HEAD	F05005-33	2	
8	CLAMP, 1/2" EMT HOSE	P07584	3	
9	WASHER, 6.5 FLAT ZINC	F81053-11	3	
10	NUT, 1/4-20 HEX LOCK	F05010-21	1	
11	STRAP, 15" RUBBER	P07461	1	
12	NUT, 1/4-20 SELF-LOCKING	F05010-21	2	
	BOTTLE ASSY, WATER LUBE	014642	1	
13	Bottle, 5-Gallon Water Lube	014637	1	
14	Cap, Water Lube Bottle Buttress Thread	014773	1	
15	FITTING, 3/4FPT X 3/4MPT	014636	1	
16	FITTING, WATER LUBE SHUTOFF VALVE	014100	1	
17	FILTER, WATER LUBE	016086 ¹	1	
18	FITTING, 5/8" NPT TO 3/8" HOSE BARB	014113	1	
19	TUBING, WATER LUBE 3/8" I.D.	R01885	2,1 m	

¹ Filter recommended for Super models to prevent debris from entering water lube solenoid valve.

4 Saw Head Saw Head Decals

4.7 Saw Head Decals

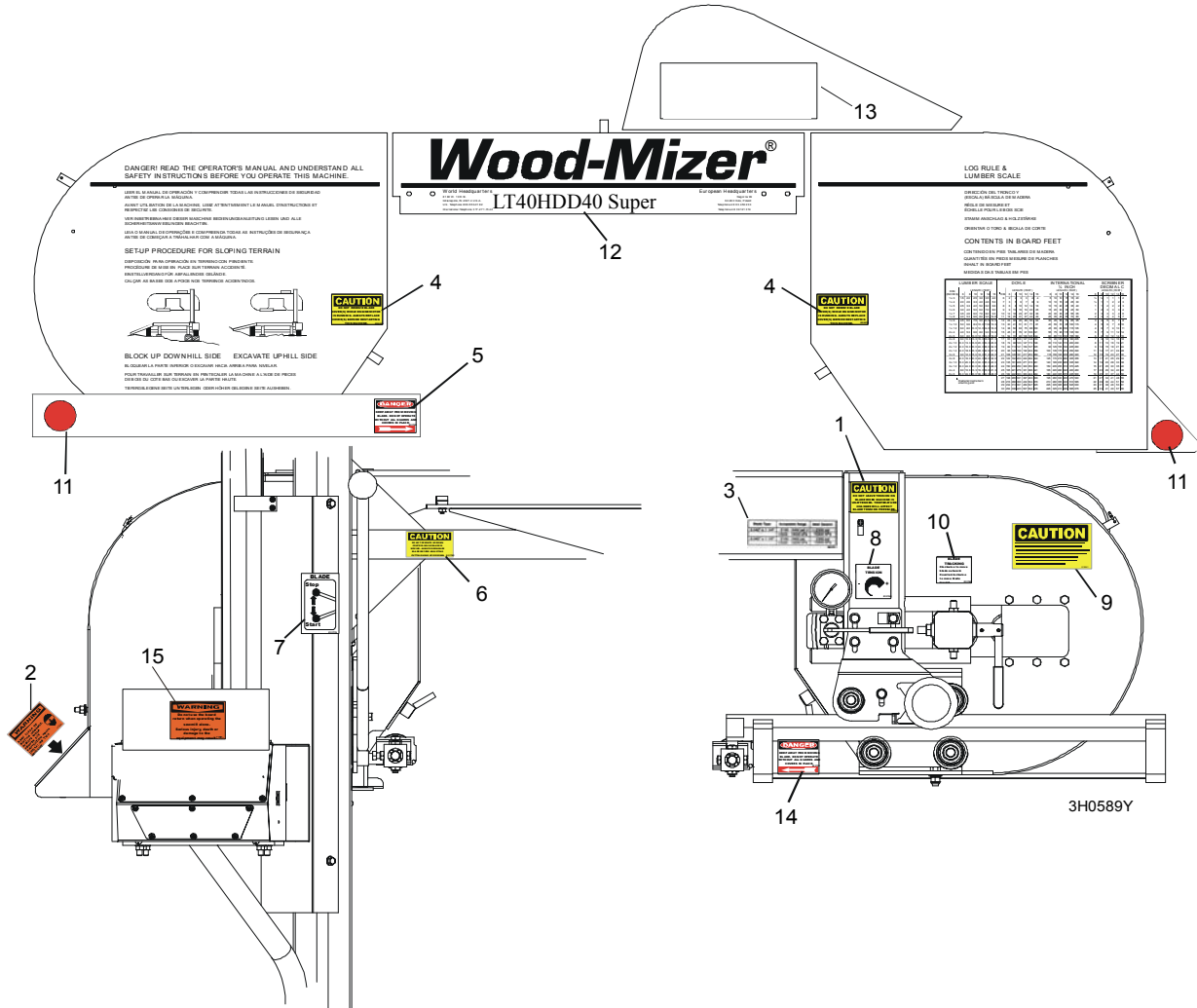

REF	DESCRIPTION (◆ Indicates Parts Available In Assemblies Only)	PART #	QTY.
1	DECAL, BLADE TENSION CAUTION	P10147	1
2	DECAL, SAWDUST CHUTE WARNING	P11754	1
3	DECAL, BLADE TENSION RANGES	085080	1
4	DECAL, BLADE COVERS CAUTION	S20039	2
5	DECAL, BLADE DANGER ARROW RIGHT	S11752	1
6	DECAL, UP/DOWN CAUTION	S11762	1
7	DECAL, BLADE START/STOP	P11779	1
8	DECAL, BLADE TENSION INFO	P11790	1
9	DECAL, SECURE THE SAW HEAD (PORTABLE SAWMILL ONLY)	S12581	1
10	DECAL, BLADE ALIGNMENT INFO	P11789	1
11	DECAL, RED REFLECTIVE 2" ROUND (PORTABLE SAWMILL ONLY)	P07452	2
12	DECAL, SAWMILL TYPE	N/A	
	Decal, LT25E11S	086885	1
	Decal, LT25G15S	086886	1

	Decal, LT25LE15S	086888	1	
	Decal, LT25LG15S	086889	1	
13	DECAL, WOOD-MIZER WHAT'S IN A NAME	S12528	1	
14	DECAL, BLADE DANGER ARROW LEFT	S11751	1	
15	DECAL, EYE/EAR PROTECTION WARNING	S11753	1	
	Decal, LT30HDD40S	086897	1	
	Decal, LT30HDE25S	086899	1	
	Decal, LT40HDD40S	086907	1	
	Decal, SUPER	085088	1	

4.8 Blade Housing Covers

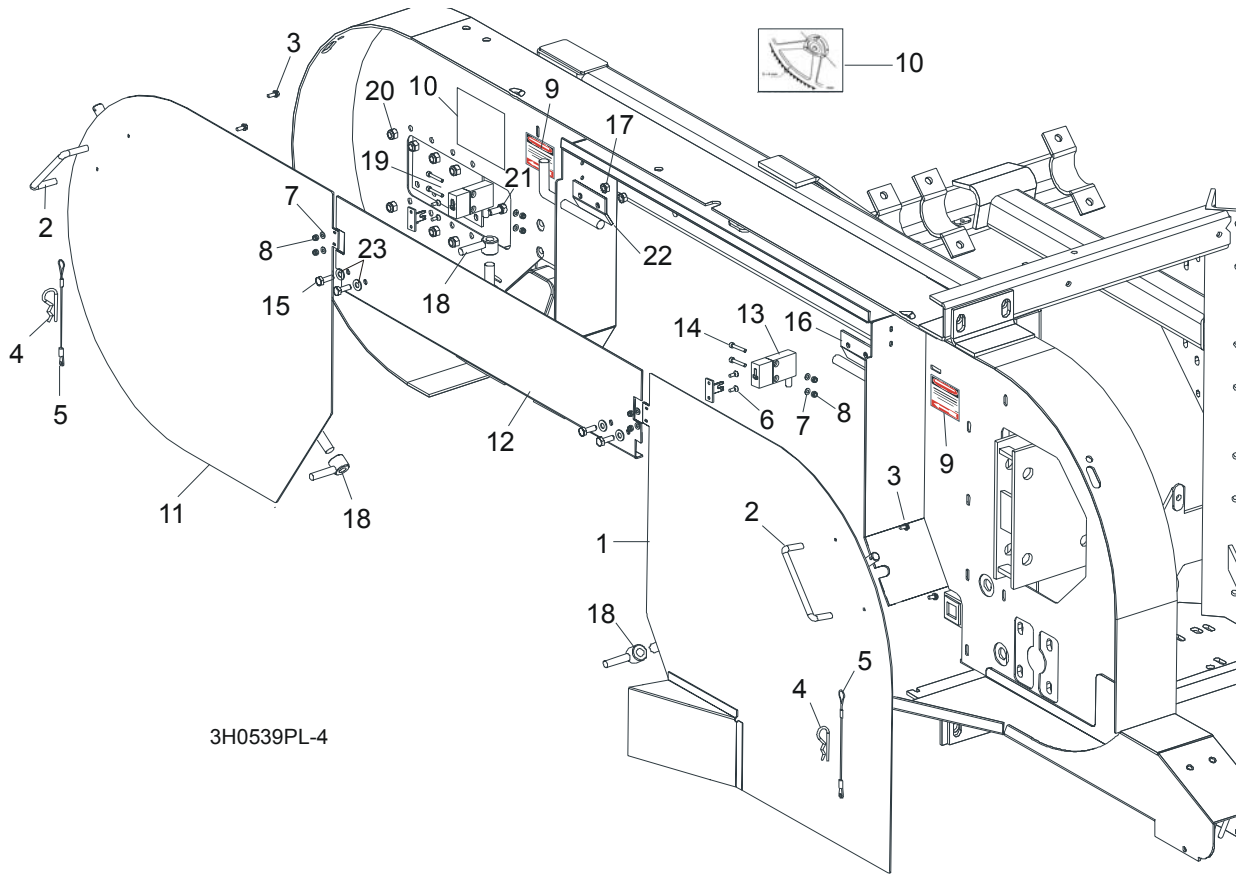

3H0539PL-4

REF	DESCRIPTION (◆ Indicates Parts Available In Assemblies Only)	PART #	QTY.	
	COVER ASSEMBLY, DRIVE SIDE BLADE HOUSING WITH HANDLE	087165	1	
1	Cover Weldment, Drive Side Blade Housing	087159-1	1	◆
2	Handle, Blade Housing Cover	P08065	1	
3	Screw, #8-32 x 3/8"	F05015-8	2	
	Pin Assembly, Cover Retainer	A11881	1	
4	Pin, Safety Retainer	N/A	1	
5	Cable, 3/64" x 6" Lanyard	N/A	1	
6	Bolt, M4 x 12-5.8	F81011-41	2	
7	Washer, 4.3	F81051-2	4	
8	Nut, M4 Hex	F81029-1	2	
9	DECAL, BLADE DANGER W/ARROW	S11751	2	
10	DECAL, BLADE SETTING	P85066	1	
	COVER, IDLE SIDE BLADE HOUSING WITH HANDLE	086431	1	
11	Cover, Idle Side Blade Housing	086430-1	1	◆
2	Handle, Blade Housing Cover	P08065	1	
3	Screw, #8-32 X 3/8" Self-Tap	F05015-8	2	

	Pin Assembly, Cover Retainer	A11881	1	
4	Pin, Safety Retainer	N/A	1	
5	Cable, 3/64" x 6" Lanyard	N/A	1	
8	Screw, M4 x 12-5.8	F81011-41	4	
9	Washer, 4.3 Flat	F81051-2	4	
10	Nut, M4 Hex	F81029-1	2	
12	COVER, MIDDLE BLADE HOUSING	087326-1	1	
13	Switch, Emergency Stop	087650	2	
14	Bolt, M4 x 20-8.8 Socket Head	F81011-31	4	
15	BOLT, 1/4-20 X 3/4" HEX HEAD	F05005-1	4	
16	HINGE, MIDDLE BLADE HOUSING COVER	S07522	1	
17	NUT, 1/4-20 SELF-LOCKING HEX	F05010-9	4	
18	NUT, COVER TURN	086365-1	2	
19	PLATE, IDLE BLADE WHEEL GUARD	086230	1	
20	NUT, 5/16-18 HEX NYLON LOCK	F05010-58	6	
21	BOLT, 5/16-18 X 3/4" HEX HEAD GRADE 2	F05006-5	6	
22	HINGE, MIDDLE BLADE HOUSING COVER	085336-1	1	
23	WASHER 6.4 ZINC	F81053-1	4	

4 Saw Head Drive Belt Covers

4.9 Drive Belt Covers

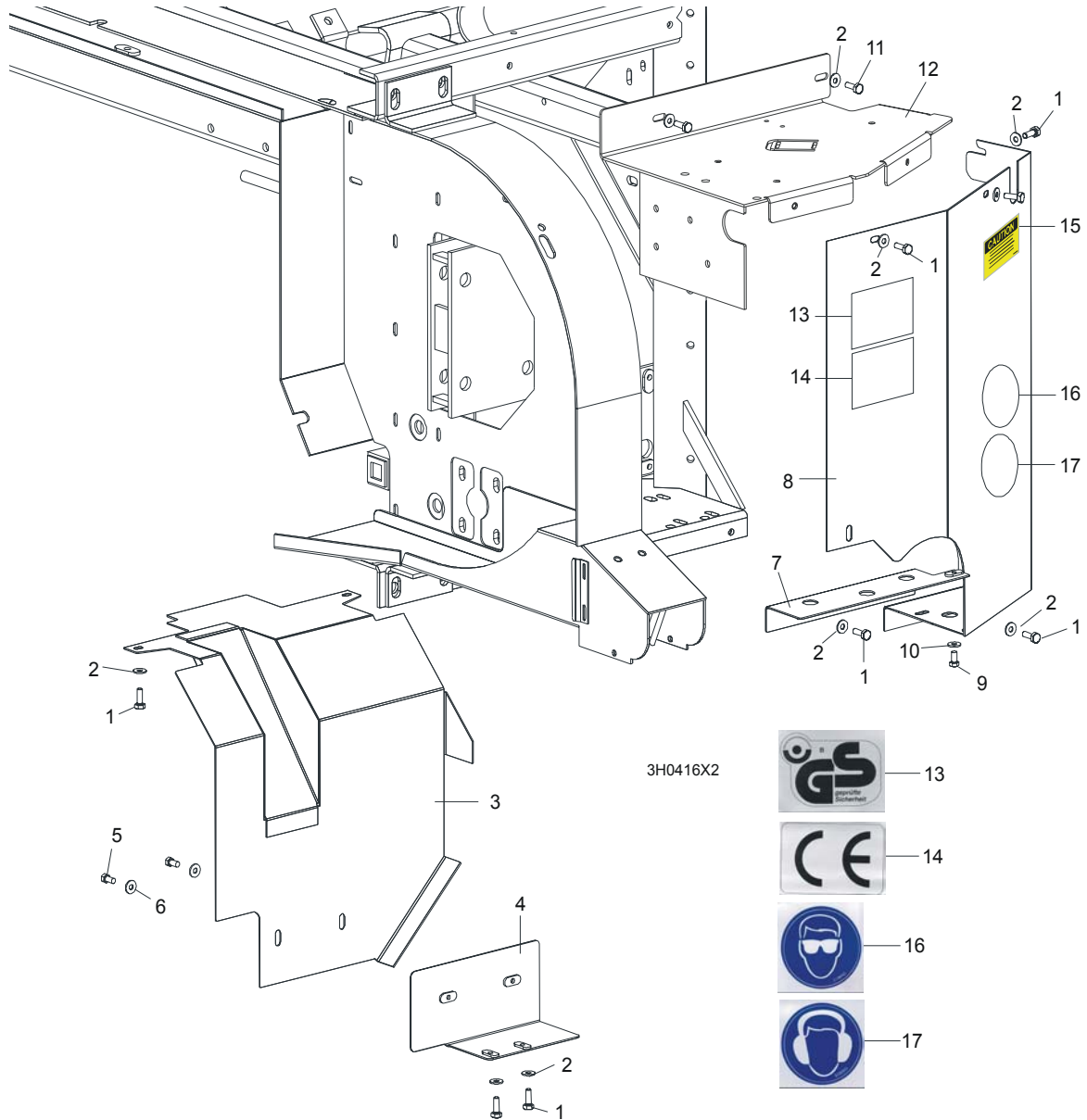

REF	DESCRIPTION (◆ Indicates Parts Available In Assemblies Only)	PART #	QTY.
1	BOLT, M6X12-8.8-ZINC	F81001-7	11
2	WASHER 6,5 ZINC	F81053-11	11
	GUARD ASSEMBLY, CLUTCH LEVER SUPER	086290 ¹	1
3	Guard Weldment, Manual Clutch	015657-1	1
4	Mount Weldment, Clutch Guard	086275-1	1
5	BOLT, M6X12-8.8-ZINC	F81001-7	2
6	WASHER 6,5 ZINC	F81053-11	2
	GUARD ASSEMBLY, DRIVE PULLEY SIDE	015155	1
7	Guard Weldment, Lower Up/Down	015654-1	1
8	Guard Weldment, C-Frame Enclosure '97	015655	1

9	Bolt, M6X12-8.8 Hex Head Zinc	F81001-7	1	
10	Washer, 6.5 Flat Zinc	F81053-11	1	
11	GUARD, DRIVE PULLEY TOP	087033-1	1	
12	DECAL, GS SAFETY CERTIFICATION	P85073	1	
13	DECAL, CE CRTIFIED SAWMILL	P85071	1	
14	DECAL, UP/DOWN MOVEMENT DANGER	A11762	1	
15	DECAL, EYE PROTECTION WARNING	S12004G	1	
16	DECAL, EAR PROTECTION WARNING	S12005G	1	

¹ Different belt guards required if sawmill is equipped with autoclutch or remote option. See Section 5.3 of the Autoclutch Option manual or Section 5.14 of the Remote Option manual.

4.10 Sawdust Chute

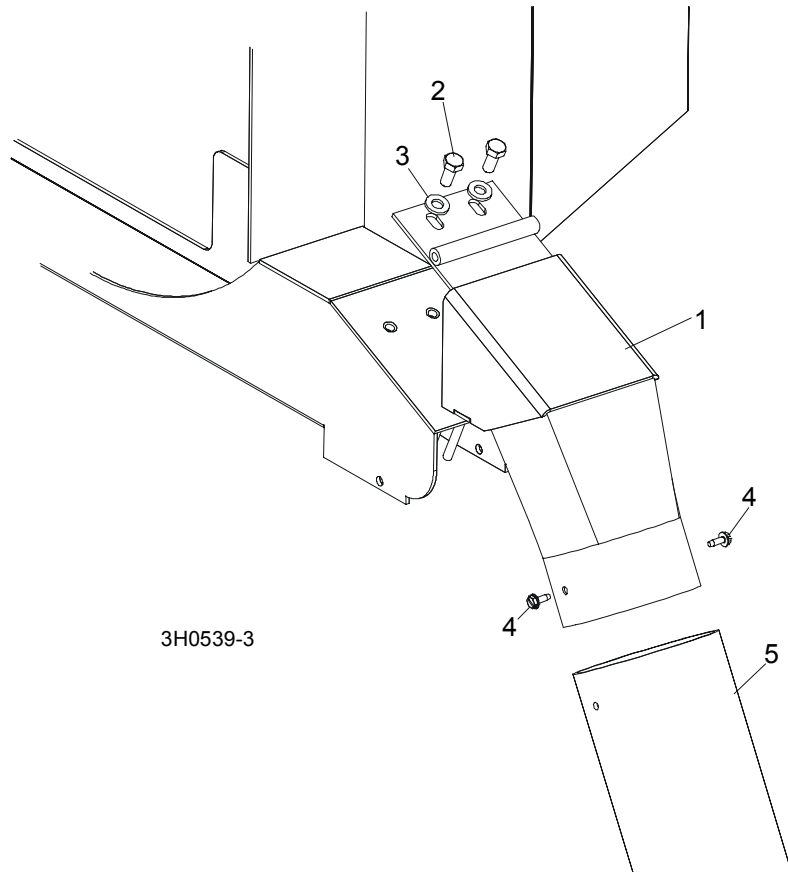

REF	DESCRIPTION (◆ Indicates Parts Available In Assemblies Only)	PART #	QTY.	
1	CHUTE WELDMENT, SAWDUST	015466	1	
2	BOLT, M8X20-8.8-B-ZINC HEX HEAD	F81002-4	2	
3	WASHER 8,4-ZINC ROUND	F81054-1	2	
4	BOLT, #10-24 X 1/2" SELF-TAPPING	F05015-7	2	
5	TUBING, 4" I.D. RUBBER	086364	0.6 m	
	STRAP, 20" RUBBER W/HOOK	P11668	1	
	BOLT, 1/4-20 X 1 1/4" HEX HEAD FULL THREAD	F05005-3	1	
	WASHER, 7.4 FLAT	F81056-11	1	
	NUT, 1/4-20 LOCK	F05010-21	1	

SECTION 5 CONTROL & BATTERY BOXES

5.1 Control Assembly, LT30HD/LT40HD Super

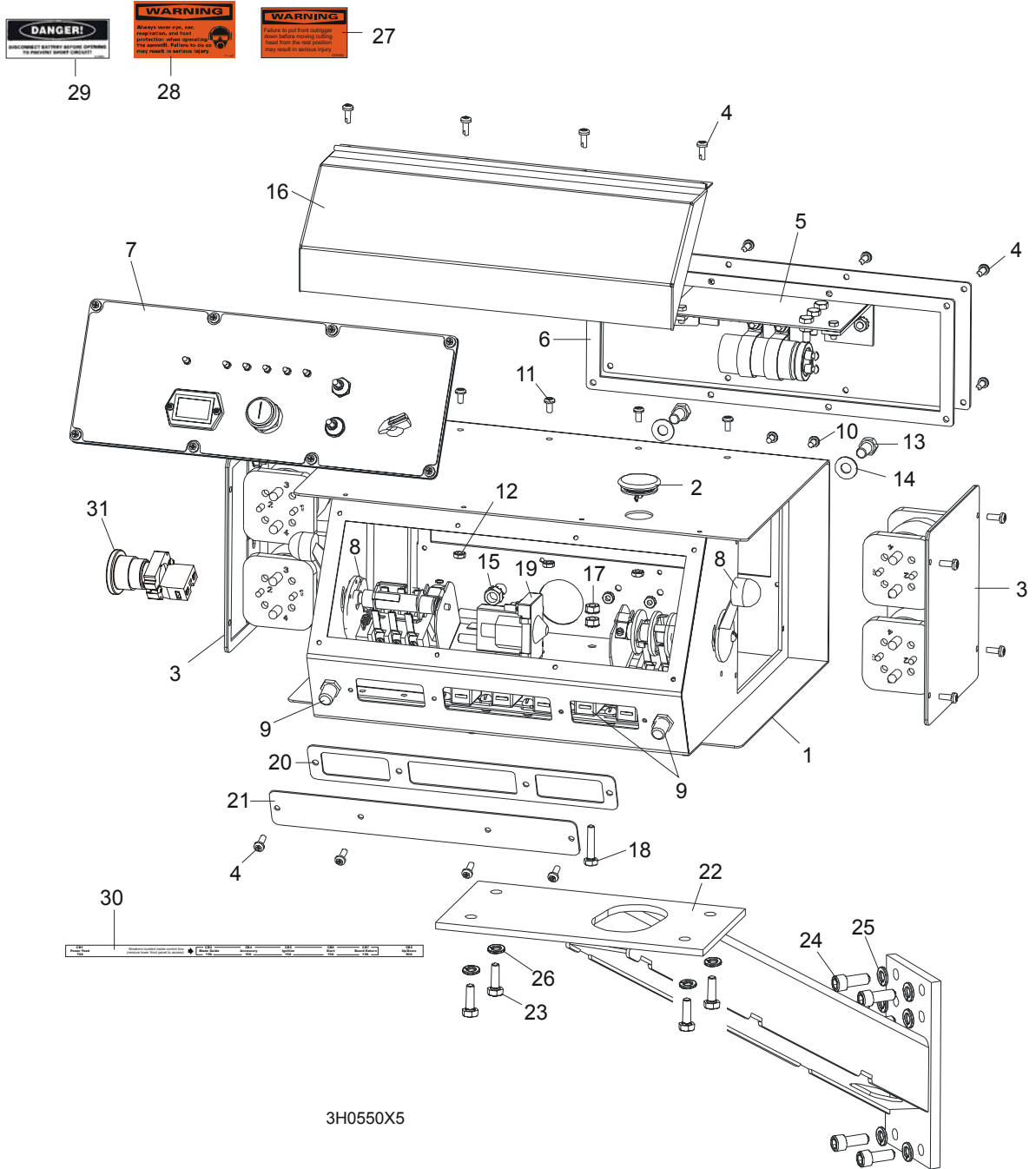

REF	DESCRIPTION (◆ Indicates Parts Available In Assemblies Only)	PART #	QTY.
-----	--	--------	------

5

Control & Battery Boxes

Control Assembly, LT30HD/LT40HD Super

	CONTROL BOX ASSEMBLY, E25	086571	1	
	CONTROL BOX ASSEMBLY, D40	086572	1	
1	Box Weldment, Sawmill Control	086694-1	1	◆
2	Plug, AS075 Oiltite	E20570	1	
3	Solenoid Parts (See Section 5.4)			
4	Screw, #10-24 x 1/2" Pan Head	F05015-17	16	
5	Panel Assembly, Power Feed Control	024412	1	
6	Gasket, Rear Access Panel	015278	1	
7	Front Control Panel & Wiring Harnesses (Section 5.5)			
8	Drum Switches (Section 5.2)			
9	Circuit Breakers (Section 5.3)			
10	Screw, #10-24 x 3/8" Phillips Pan Head	F05004-3	2	
11	Screw, #10-24 x 3/8" Phillips Pan Head Machine with Neo Washer	F05004-148	4	
12	Nut, #10-24 Self Locking	F05010-14	6	
13	Bolt, 3/8-16 x 3/4" Hex Head	F05007-27	2	
14	Washer, 10.5 Flat	F81055-1	2	
15	Nut, 3/8" Lock Nut	F05010-19	2	
16	Cover, Control Box Hinged	015304	1	
17	Nut, 1/4-20 Self Locking	F05010-9	2	
18	Bolt, 1/4-20 x 1 1/4" Hex Head Tap	F05005-3	1	
19	Solenoid, Accessory	P10449	1	
20	Gasket, Front Access Panel	015266	1	
21	Panel, Control Box Front Access	086704-1	1	
22	MOUNT WELDMENT, STANDARD CONTROL BOX	086732-1	1	
23	BOLT, M8X20-8.8-B HEAD HEX ZINC	F81002-4	4	
24	BOLT, M10 X 25-8.8 SOCKET HEAD	F81003-32	6	
25	WASHER, 10.2 SPLIT LOCK	F81055-2	6	
26	WASHER, 8.4 FLAT	F81054-1	4	
27	DECAL, FRONT OUTRIGGER WARNING	015400	1	
28	DECAL, EAR/EYE PROTECTION WARNING	S11753	1	
29	DECAL, DISCONNECT BATTERY DANGER	S12002	1	
30	DECAL, CIRCUIT BREAKER ID ('98 SUPER)	024362	1	
31	SWITCH, RED EMERGENCY STOP XB4 BS542	086556	1	

5.2 Drum Switches

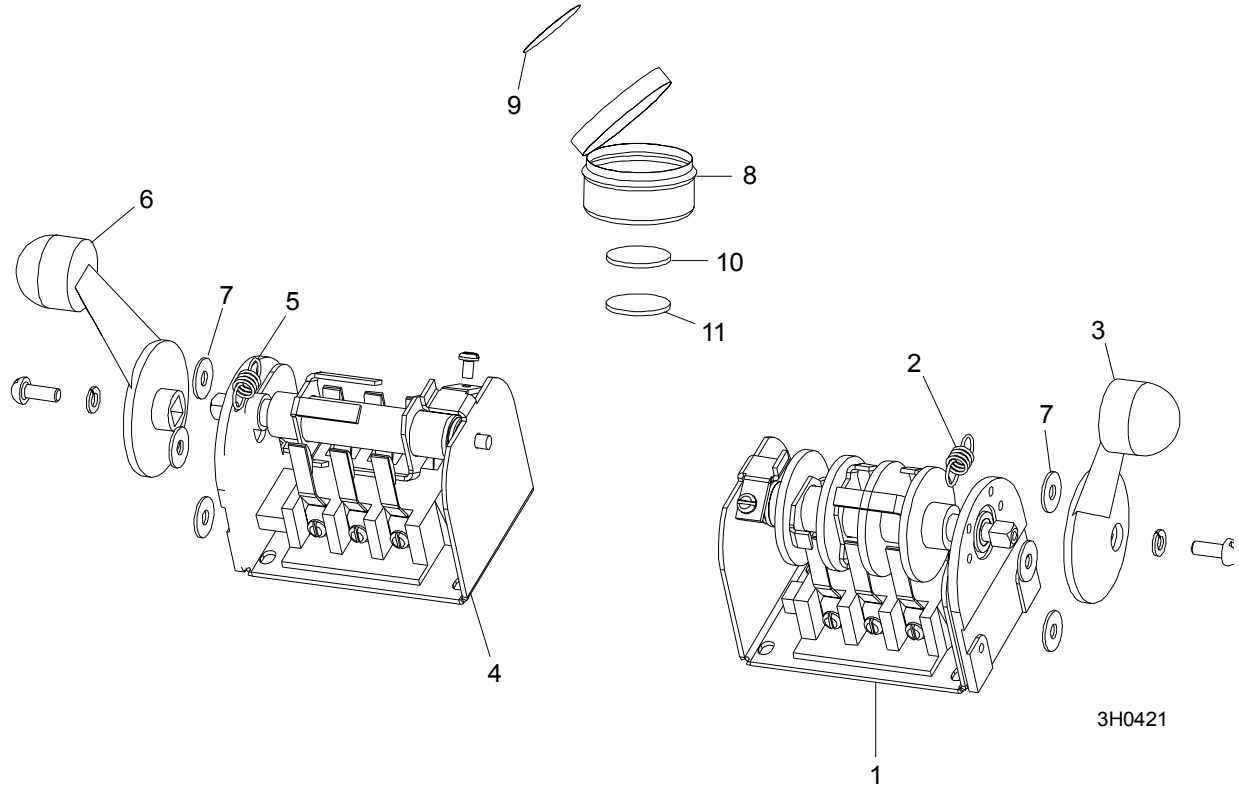

REF	DESCRIPTION (◆ Indicates Parts Available In Assemblies Only)	PART #	QTY.	
	SWITCH ASSEMBLY, UP/DOWN DRUM	E20440	1	
1	Switch, S12 Bulk Drum	E20440-B	1	◆
2	Spring, Drum Switch	P12570	1	
3	Handle, Drum Switch Replacement	P12500	1	
	SWITCH ASSEMBLY, POWER FEED DRUM	E20438	1	
4	Switch, S10 Bulk Drum	E20438-B	1	◆
5	Spring, Drum Switch	P12570	1	
6	Handle, Drum Switch Replacement	P12500	1	
7	WASHER, #8 SAE FLAT	F05011-41	6	
	CUP ASSEMBLY, DRUM SWITCH GREASE	A20463	1	
8	Cup, Plastic Container	P20464	1	◆
9	Decal, Grease Cup Label	P20467	1	
10	Pad, Velcro Loop	P20466	1	◆
11	Pad, Velcro Hook	P20465	1	◆
	Grease, High Temp Drum Switch	P20468	.011m	◆

5.3 Circuit Breakers

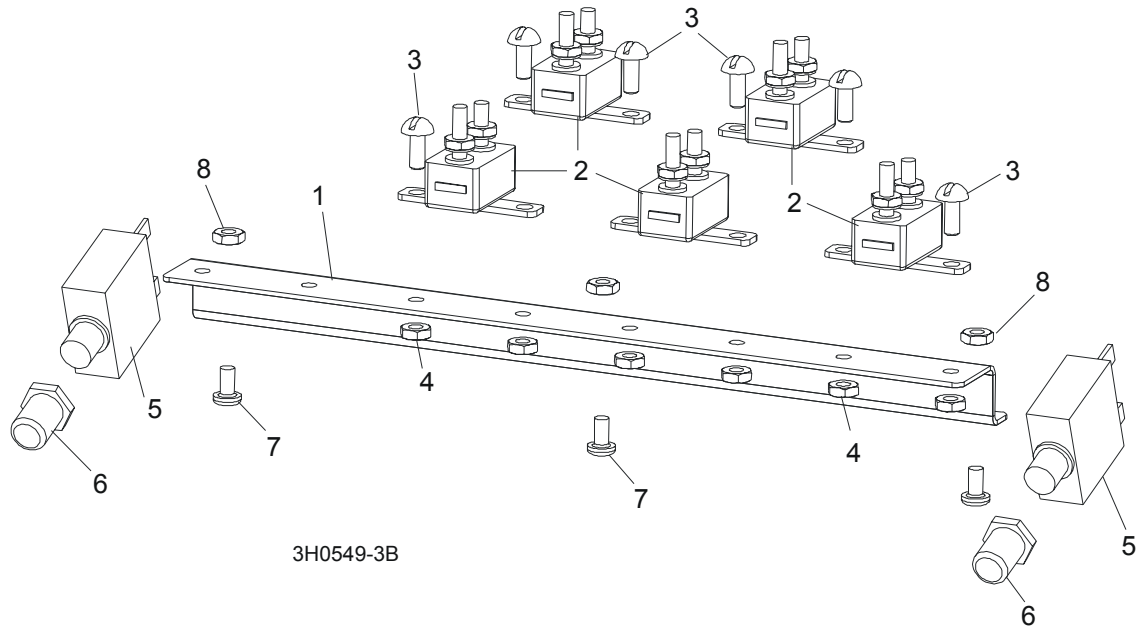

REF	DESCRIPTION (◆ Indicates Parts Available In Assemblies Only)	PART #	QTY.
	BREAKER ASSEMBLY, SAWMILL CONTROL CIRCUIT	015621	1
1	Rail, Circuit Breaker	015310	1
2	Breaker, 15 Amp Manual Reset	E20430	5
3	Screw, H M5x10 8.8 Slotted Head Zinc	F81000-13	6
4	Nut, M5-8 Hex Self-Locking Zinc	F81030-2	6
5	BREAKER, 70 AMP MANUAL RESET PANEL MOUNT	015527	2
6	BOOT, CIRCUIT BREAKER	021253	2
7	BOLT, M5X12-5.8 ZINC	F81000-5	3
8	NUT, M5-8 SELF LOCKING ZINC	F81030-2	3

5.4 Solenoid Assemblies

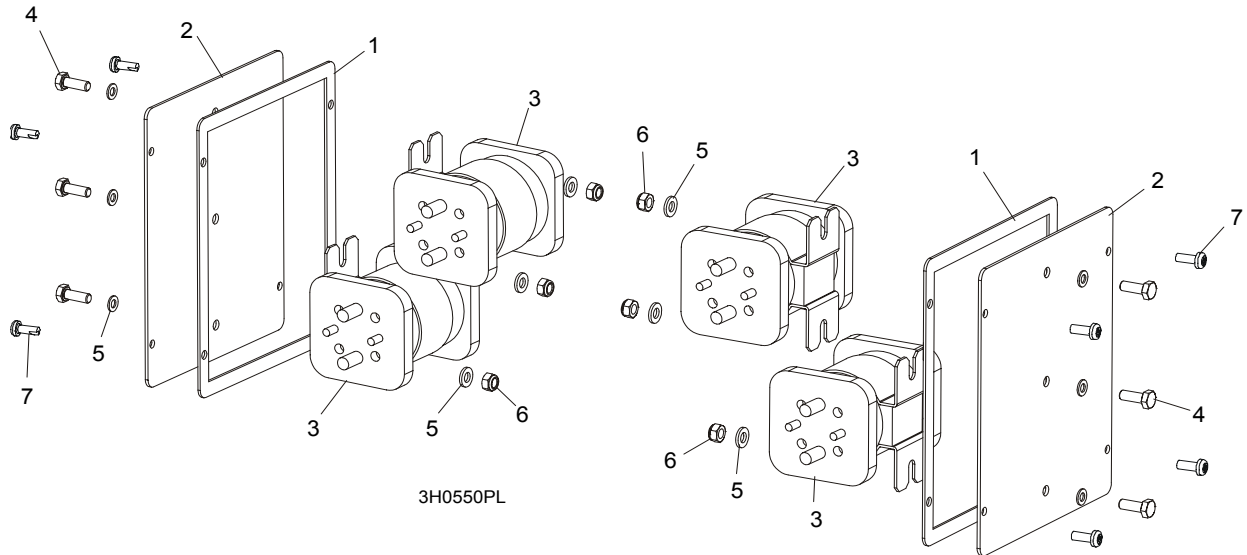

REF	DESCRIPTION (◆ Indicates Parts Available In Assemblies Only)	PART #	QTY.
1	GASKET, SIDE PANEL CONTROL	015274	2
2	PANEL WELDMENT, SIDE	086699-1	2
3	SOLENOID, 200A 12V DPST	015417	4
4	BOLT, M6 X 16-5.8 HEX HEAD	F81001-14	6
5	WASHER, 6.4 FLAT	F81053-1	12
6	NUT, M6-8 HEX	F81031-2	6
	DIODE ASSEMBLY, SOLENOID COIL CHASSIS GND	087496	4
7	SCREW, #10-24 X 1/2" PAN HEAD	F05015-17	8

5.5 Front Panel Assembly & Harnesses

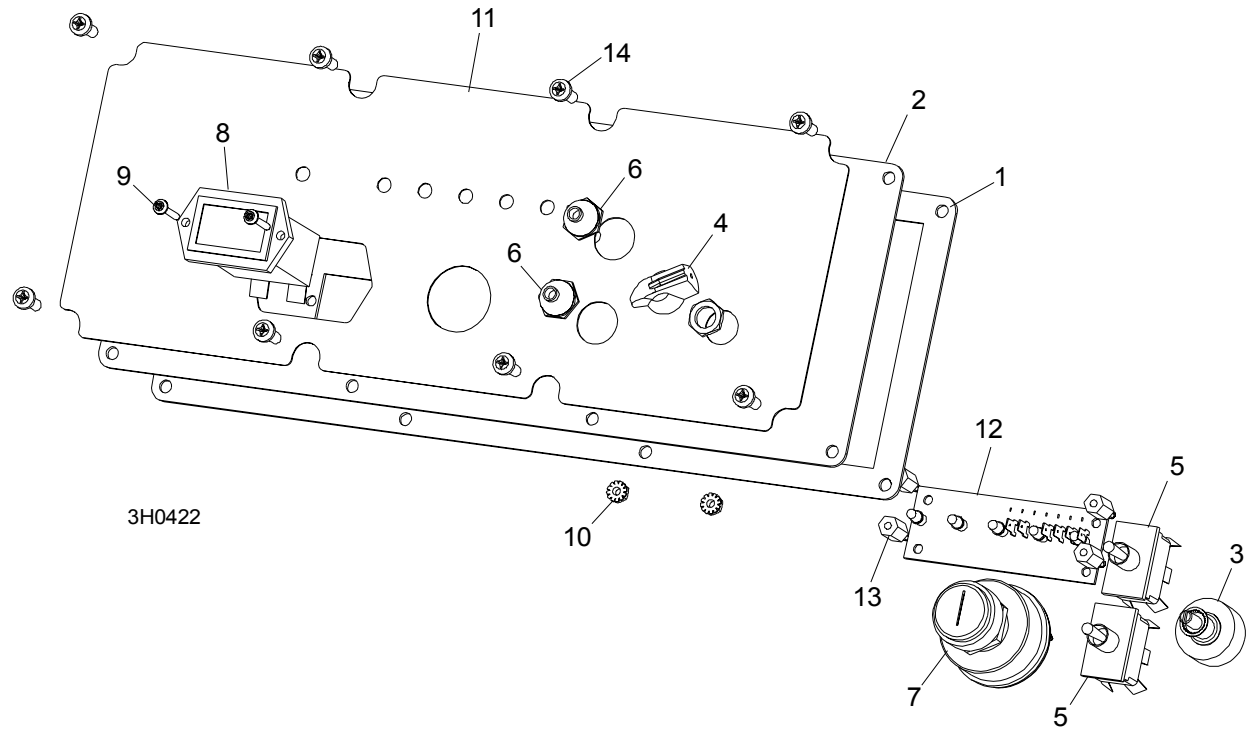

REF	DESCRIPTION (◆ Indicates Parts Available In Assemblies Only)	PART #	QTY.
	PANEL ASSEMBLY, CONTROL FRONT (D40)	087401	1
1	Gasket, Front Panel	088387	1
2	Panel Weldment, Control	015302	1
3	Switch Assembly, Feed Rate	E20519	1
4	Knob, Feed Rate With Set Screw	P06257	1
5	Switch, Toggle	024200	2
6	Boot, Toggle Switch Rubber	P02575	2
7	Switch, Key	P04350	1
8	Meter, Hour	015401	1
9	Bolt, M3x12 -8.8 Zinc	F81000-12	2
10	Nut, M3-6 Self Locking Zinc	F81028-2	2
11	Decal, Control Panel (D40)	015269	1
12	Board, LED Circuit D38/D40	089694	1
13	Spacer, 1/2" -#6 Threaded	023147	4
	HARNESS ASSEMBLY, UPPER WIRING (D40)	087107	1
	HARNESS ASSEMBLY, LOWER WIRING (D40)	087108	1
14	Screw, #10-24 x 1/2" Pan Head	F05015-17	8

5.6 Battery Box Assembly, LT30HD/LT40HD Super

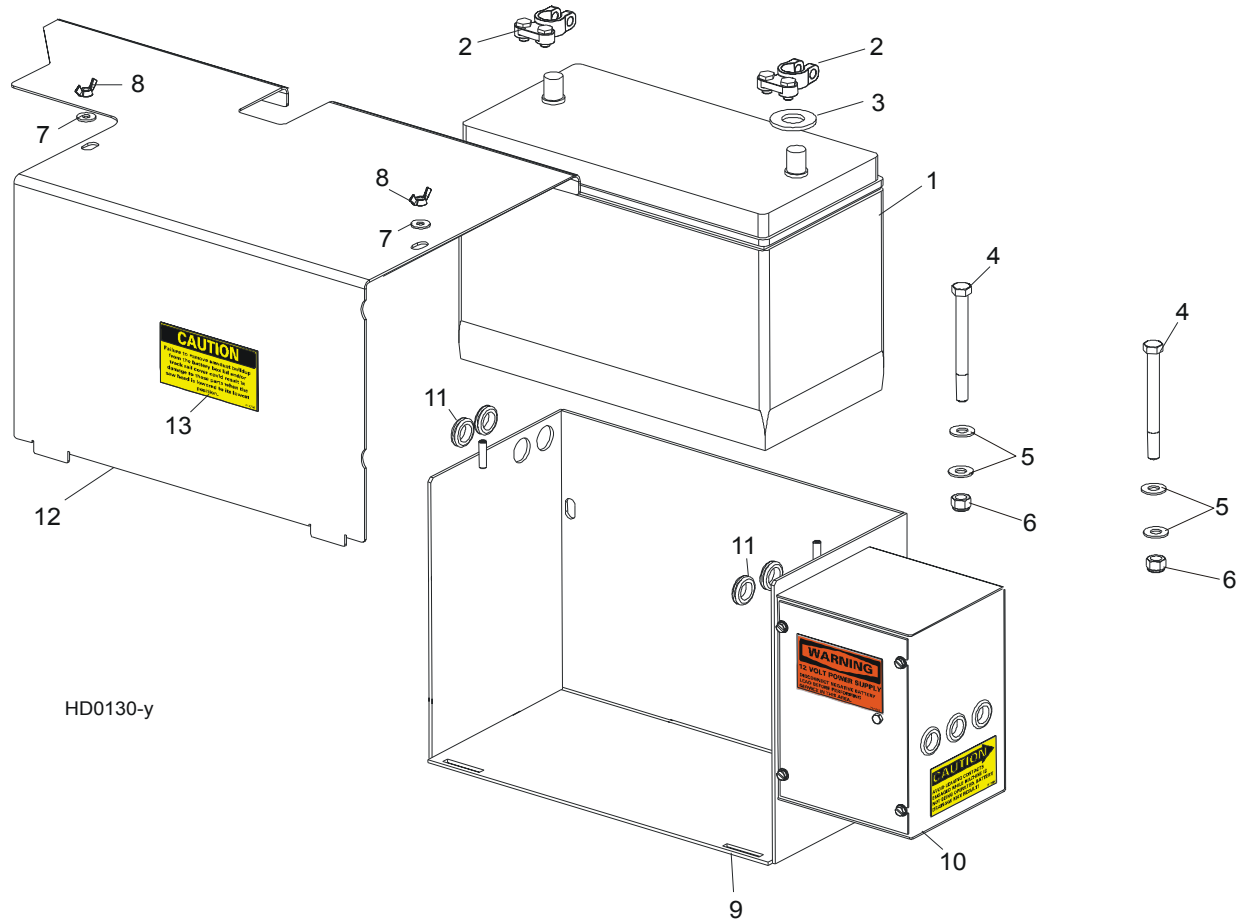

HD0130-y

REF	DESCRIPTION (◆ Indicates Parts Available In Assemblies Only)	PART NUMBER	QTY.	
1	BATTERY, "BANNER" 12V100AH #95751	088323	1	
	BOX ASSEMBLY, LT30HD/LT40HD SUPER BATTERY	086510	1	
2	Terminal, Battery	P05085	2	
3	Washer, Battery Terminal	P12161	1	
4	Bolt, 3/8-16 X 4" Hex Head Grade 2	F05007-4	2	
5	Washer, 10.5 Flat	F81055-1	4	
6	Nut, 3/8" Hex Nylon Lock	F05010-10	2	
7	Washer, 7.4 Flat	F81056-11	2	
8	Nut, 1/4-20 Wing	F05010-13	2	
9	Box Weldment, Battery	086265-1	1	
10	Fuse Box Parts (See Section 5.7)			
11	Grommet, 5/8" Rubber Wire	P11764	5	
	Contact Assembly, Hydraulic Positive (See Section 9.3)	085968	1	
12	LID WELDMENT, BATTERY BOX SUPER	086277-1	1	
13	DECAL, BATTERY BOX LID CAUTION	014774	1	

5.7 Fuse Box Assembly, LT30HD/LT40HD Super

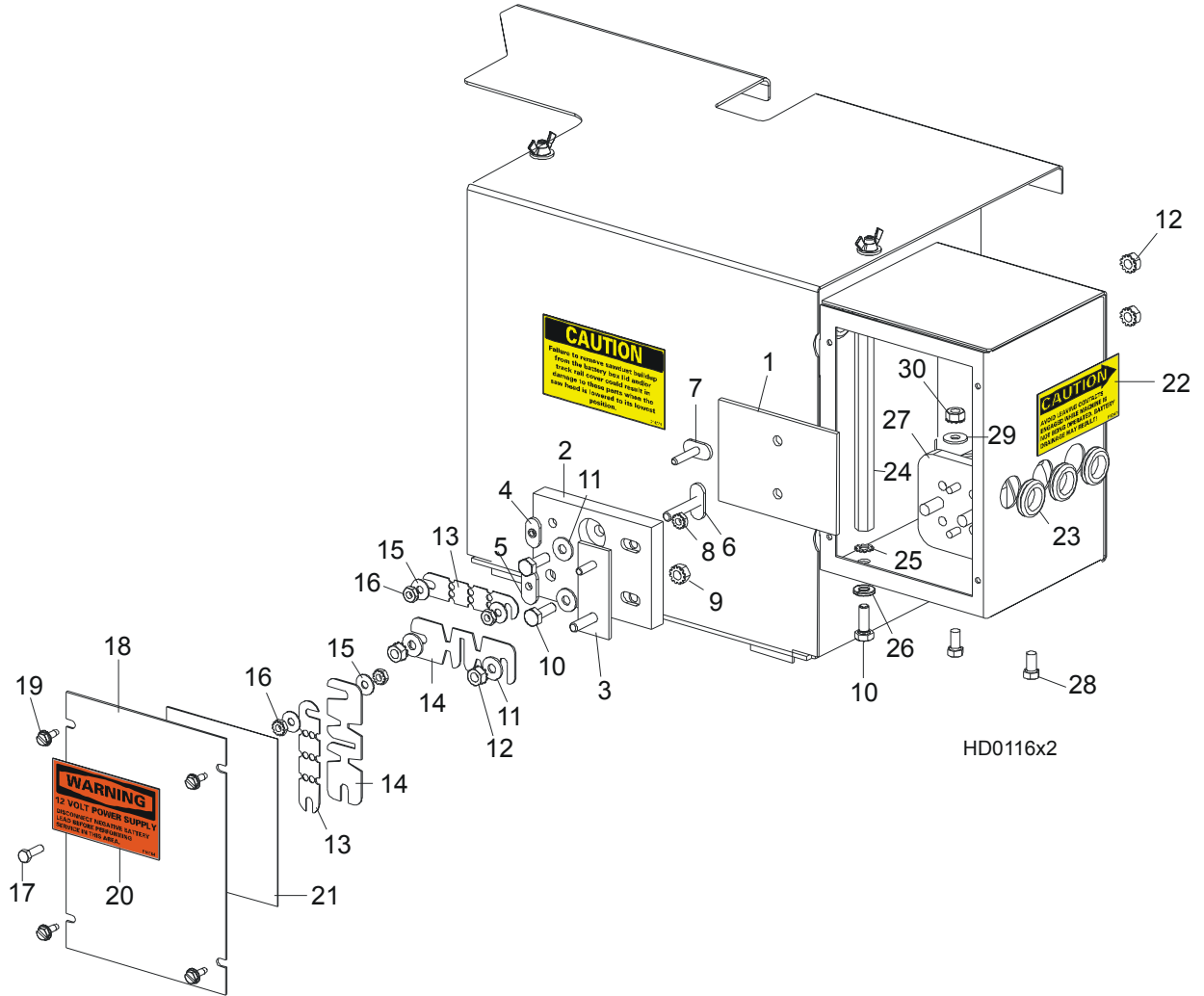

REF	DESCRIPTION (◆ Indicates Parts Available In Assemblies Only)	PART NUMBER	QTY.	
1	PAD, FUSE BOX INSULATOR	015287	1	
	FUSE BLOCK ASSEMBLY	017665	1	
2	Block, Fuse Mount	015286	1	◆
3	Buss Weldment, Fuse Mount	015289	1	◆
4	Nut, #10-24 Cadmium Plated Weld	S12391	1	◆
5	Nut, 1/4-20 Cadmium Plated Weld	S12392	1	◆
6	Stud Weldment, 1/4-20 Fuse	W12389	1	◆
7	Stud Weldment, #10-24 Fuse	W12390	1	◆
8	Nut, #10-24 Self-Locking Hex	F05010-14	1	◆
9	Nut, 1/4-20 Self-Locking Hex	F05010-9	1	◆
10	BOLT, 1/4-20 X 3/4" HEX HEAD FULL THREAD	F05005-1	3	
11	WASHER, 7.4 FLAT	F81056-11	4	
12	NUT, 1/4-20 HEX SELF-LOCKING	F05010-9	4	
13	FUSE LINK, 12 VOLT 150 AMP	023361	2	

14	FUSE LINK, 12 VOLT 225 AMP	P11550	2	
15	WASHER, 5.3 FLAT	F81052-1	4	
16	NUT, #10-24 HEX SELF-LOCKING	F05010-14	4	
17	SCREW, #10-24 X 5/8" HEX HEAD	F05004-18	1	
18	COVER, FUSE BOX	086272-1	1	
19	SCREW, #10-24 X 1/2" SELF-TAPPING	F05015-7	4	
20	DECAL, 12 VOLT WARNING	P10364	1	
21	DECAL, '97 SUPER HYDRAULIC	015372	1	
22	DECAL, HYDRAULIC CONTACT CAUTION	P12960	1	
23	GROMMET, 5/8" RUBBER WIRE	P11764	3	
24	TERMINAL, EXTENDED HEX STUD	015517	1	
25	WASHER, 6.4 EXTERIOR STAR	F81053-2	1	
26	WASHER, 6.1 SPLIT LOCK	F81053-3	1	
27	SOLENOID, 200A 12V SPST CONT. DUTY	015470	1	
28	BOLT, 1/4-20 X 1/2" HEX HEAD	F05005-15	2	
29	WASHER, 7.4 FLAT	F81056-11	2	
30	NUT, 1/4-20 SELF-LOCKING HEX	F05010-9	2	

SECTION 6 UP/DOWN SYSTEM

6.1 Saw Head V-Brace Mount

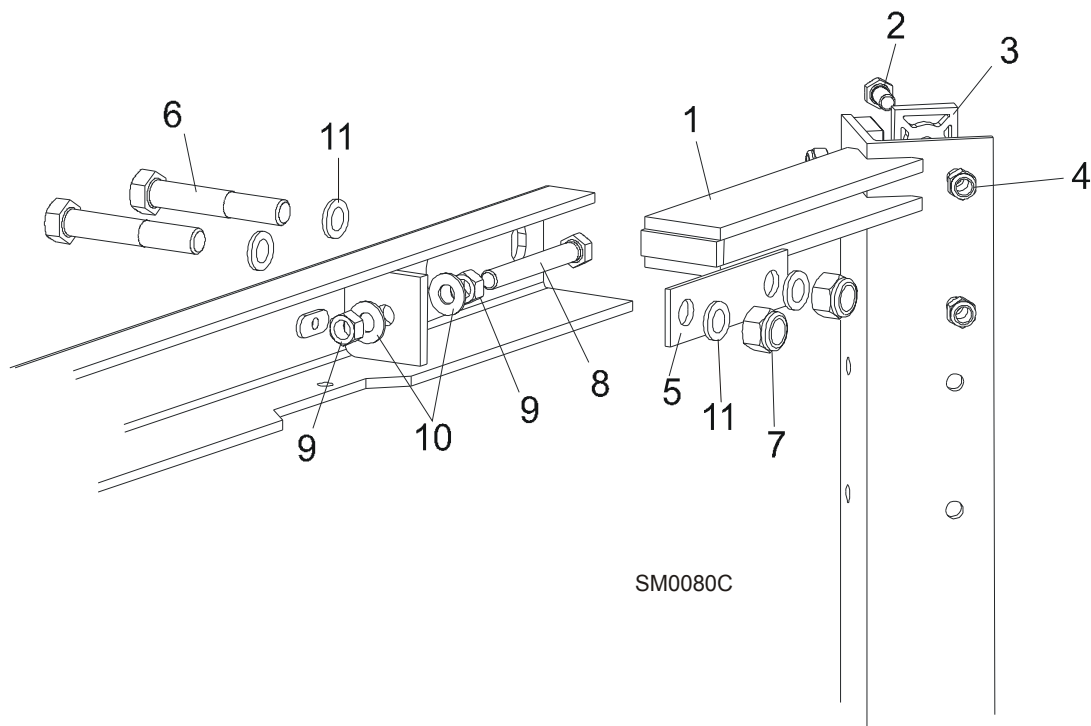

REF	DESCRIPTION (◆ Indicates Parts Available In Assemblies Only)	PART #	QTY.
1	V-BRACE, SAW HEAD MOUNT	087125	1
2	BOLT, M8X20-5.8-ZINC HEX HEAD	F81002-4	10
	BOLT, M8X25-8.8-B-ZINC HEX HEAD	F81002-5	2
3	PAD, PLASTIC SLIDE	M04096	6
4	NUT, M8-8-B-ZINC HEX NYLON LOCK	F81032-2	12
5	PLATE, V-BRACE WASHER	091247	2
6	BOLT, M12X75-8.8-ZINC	F81004-21	4
7	NUT, M12 - 8 NYLON LOCK	F81034-2	4
8	BOLT, M10X70-8.8-ZINC HEX HEAD	F81003-20	2
9	NUT, M10-8-B-ZINC HEX	F81033-3	4
10	WASHER, 10.5 FLAT	F81055-1	4
11	WASHER, 13 SPLIT LOCK ZINC	F81056-1	8

6.2 Blade Height Scale

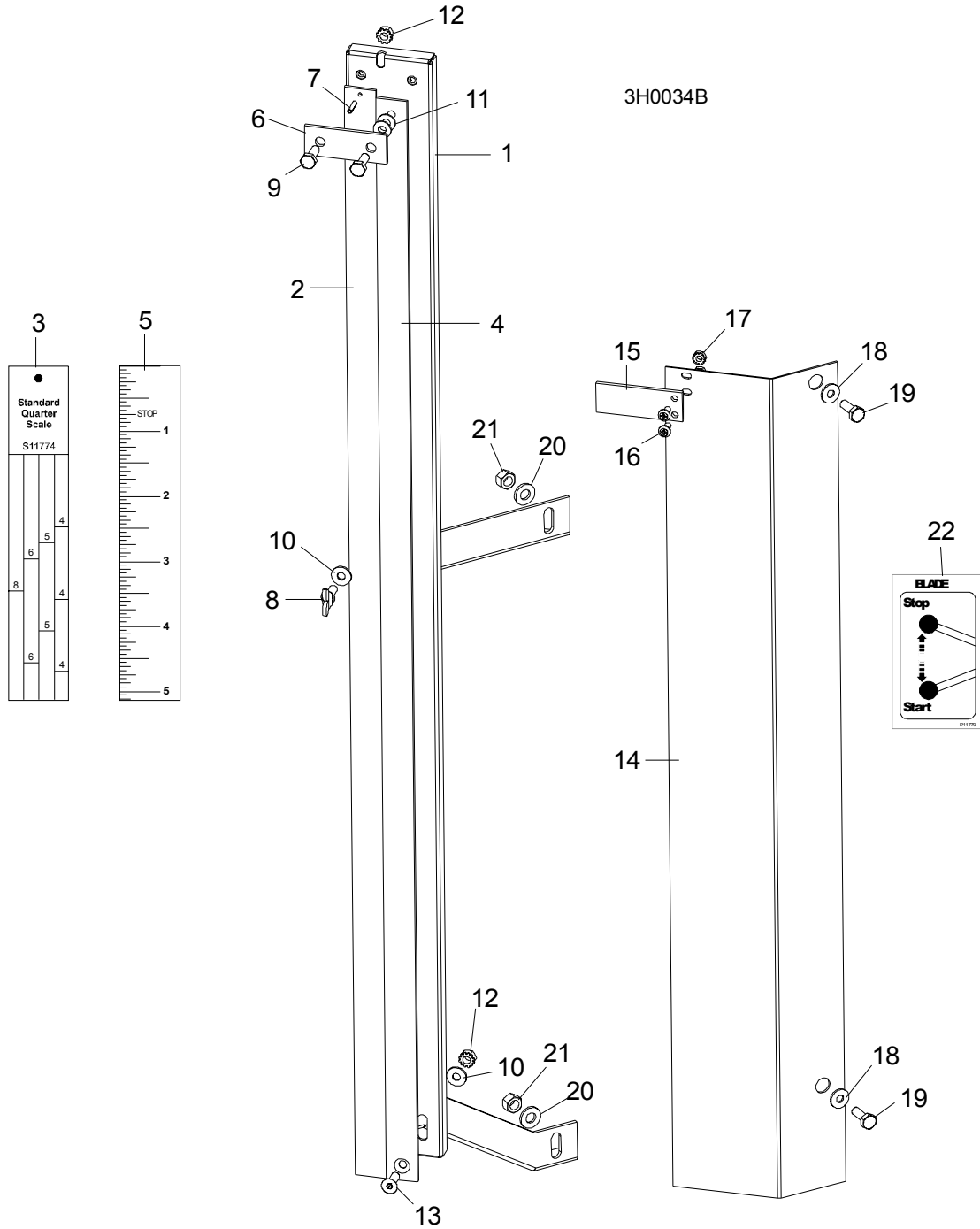

REF	DESCRIPTION (◆ Indicates Parts Available In Assemblies Only)	PART #	QTY.	
	SCALE RETROFIT, FIXED WITH POINTER	A12030	1	
	Scale Kit, Fixed With Pointer	K11998	1	◆
	Scale Assembly, Fixed	A12022	1	◆
1	Bracket, Scale Mounting	W11996-1	1	

6

Up/Down System

Blade Height Scale

2	Scale, 35" Quarter	S11989	1	
3	Decal, 35" Standard Quarter Scale	S11774	1	
	Decal, 35" Grade Hardwood Quarter Scale	P12819	1	
4	Scale, 35" Inch	S11988	1	
5	Decal, 35" Inch	S11773	1	
6	Strap, Scale Hold-Down	S04805	1	
7	Pin, 1/8" X 5/8" Roll	F05012-14	1	
8	Screw, 1/4-20 X 5/8" Wing	F05005-64	1	
9	Bolt, M6x20-8.8-Zinc	F81001-2	2	
10	Washer, 6.5 Flat	F81053-11	2	
11	Washer, 1/4" X .020 Thick Nylon Flat	F05011-22	2	
12	Nut, 1/4-20 Hex Self-Locking	F05010-9	1	
13	Screw, 1/4-20 X 3/4" Flat Socket Head	F05005-70	1	
	Pointer Assembly, Fixed Scale	A12023	1	
14	Bracket, Fixed Scale Pointer Mount	087044-1	1	◆
15	Pointer, Fixed Scale	086691	1	
16	Screw, #10-24 X 3/8" Phillips Head	F05004-3	2	
17	Nut, #10-24 Hex Self-Locking	F05010-14	2	
18	Washer, 6.5 Flat	F81053-11	2	
19	Bolt, M6x12-8.8-Zinc	F81001-7	2	
20	Washer, 8.4 Flat	F81054-1	2	
21	Nut, M8-8-B Hex Lock	F81032-2	2	
	Bolt, 1/4-20 X 1/2" Hex Head Grade 2	F05005-15	1	
	Instruction Sheet, Fixed Scale Retrofit	A12030-370	1	
	DECAL KIT, METRIC SCALE	K12064	1	
	Decal, Metric	S11711	1	
	Decal, Metric 16-40mm	P12040-1	1	
	Decal, Metric 45-63mm	P12040-2	1	
22	DECAL, CLUTCH HANDLE OPERATION	P11779	1	

6.3 Up/Down Chain & Sprockets

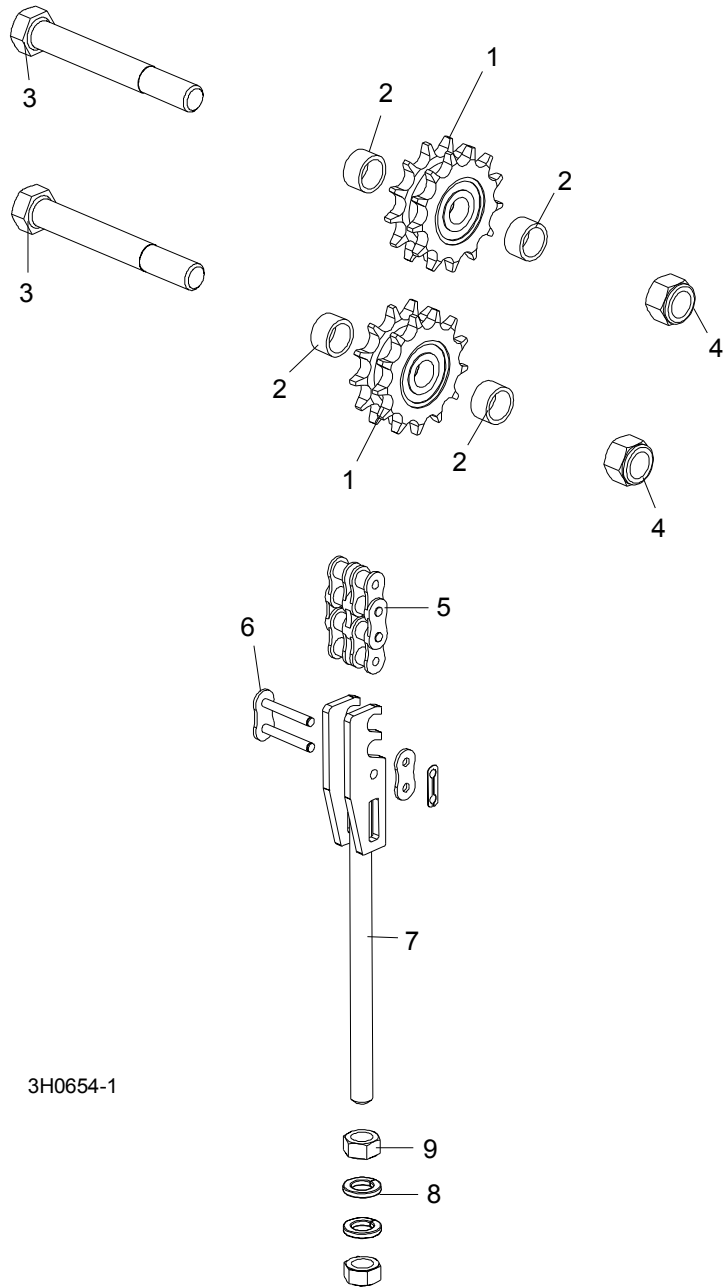

3H0654-1

REF	DESCRIPTION (◆ Indicates Parts Available In Assemblies Only)	PART #	QTY.
	SPROCKET KIT, UP/DOWN IDLER #50-2	016020	1
1	Sprocket, Up/Down Idler '98	016019	2
2	Spacer, 50-2 Idler '98	016018	4
	Instruction Sheet, Up/Down Idler Retrofit	016020-541	1
3	BOLT, 5/8-11 X 5" HEX HEAD GRADE 2	F05009-6	2

6

Up/Down System*Up/Down Chain & Sprockets*

4	NUT, 5/8-11 HEX NYLON LOCK	F05010-34	2	
5	CHAIN, #50-2 X 75.625" UP/DOWN	015259	1	
6	LINK, #50-2 MASTER	015258	2	
	TENSIONER ASSEMBLY, UP/DOWN CHAIN	086219	1	
7	Bracket, Up/Down #50 Chain Tensioner	086205-1	1	◆
8	Washer, 12.2 Split Lock	F81056-2	2	
9	Nut, M12-8-B Hex	F81034-1	2	

6.4 Up/Down Motor Assembly, LT30HD/LT40HD Super

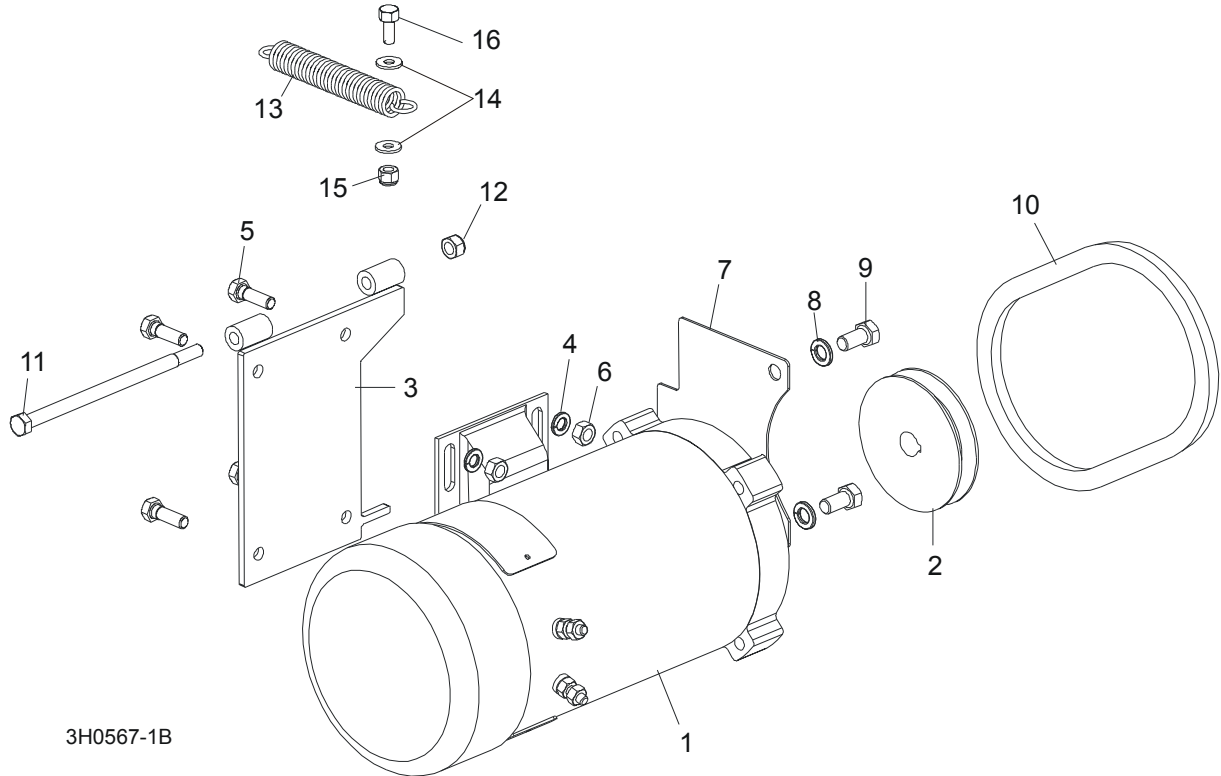

REF	DESCRIPTION (◆ Indicates Parts Available In Assemblies Only)	PART #	QTY.
	UP/DOWN MOTOR ASSEMBLY	015177	1
1	Motor, 3/4 HP Electric	015174	1
	Brush Kit, Power Feed Motor (Includes 2 Brushes and 2 Springs)	024167	1
	Fan, 3/4 HP Leeson Motor Replacement	016087	1
2	Pulley, Up/Down Motor	015255	1
3	Bracket, Up/Down Motor Mount	015198	1
4	Washer, 8.2 Split Lock	F81054-4	4
5	Bolt, 5/16-18 x 1" Hex Head	F05006-1	4
6	Nut, 5/16-18 Hex	F05010-17	4
7	Guard, Up/Down Sprocket	015016	1
8	Washer, 10.2 Split Lock	F81055-2	2
9	Bolt, 3/8-16 x 3/4" Hex Head	F05007-27	2
10	BELT, AX23	015257 ¹	1
11	BOLT, 5/16-18 X 6" HEX HEAD GRADE 5	F05006-73	1
12	NUT, 5/16-18 HEX NYLON LOCK	F05010-65	1
13	SPRING, .75" X 5" X .095" EXTENSION	015569	1
14	WASHER, 6.5 FLAT ZINC	F81053-11	2
15	NUT, M6-8-B NYLON LOCK HEX ZINC	F81031-2	2
16	BOLT, M6x25-8.8 ZINC	F81001-20	1

6 Up/Down System

Up/Down Drive Assembly, LT30HD/LT40HD Super

6.5 Up/Down Drive Assembly, LT30HD/LT40HD Super

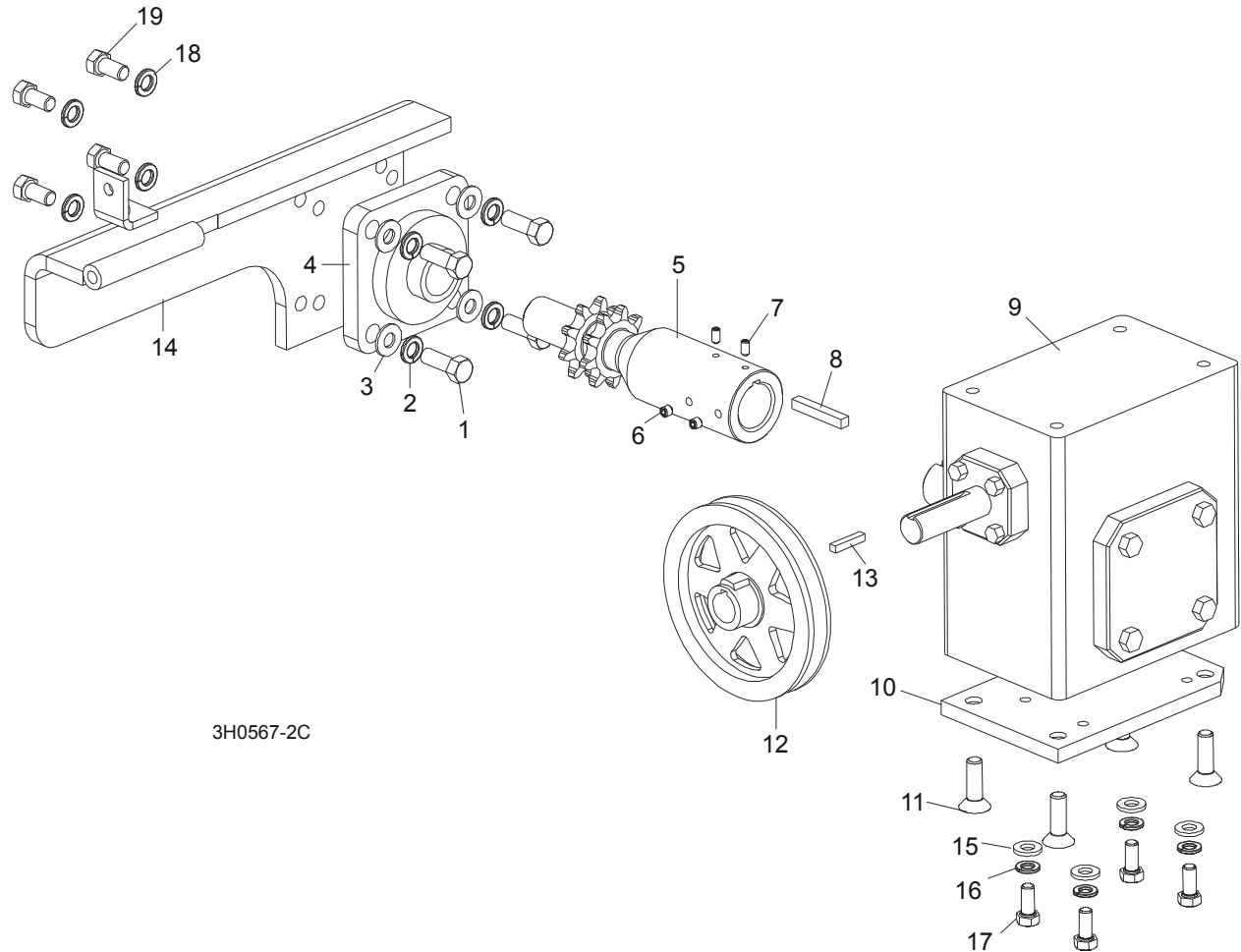

REF	DESCRIPTION (◆ Indicates Parts Available In Assemblies Only)	PART #	QTY.	
	UP/DOWN DRIVE ASSEMBLY	015176-0	1	
1	Bolt, 3/8-16 x 1" Hex Head	F05007-7	4	
2	Washer, 10.2 Split Lock	F81055-2	4	
3	Washer, 10.5 Flat	F81055-1	4	
4	Bearing, Flanged Up/Down	014090	1	
5	Shaft, Up/Down Sprocket	086587-1	1	
6	Screw, M8 x 8-33H	F81014-1	2	
7	Screw, M8 x 8-33H	F81014-1	2	
8	Key, 1/4" Square x 1 11/16" Long	S04124	1	
9	Reducer, Gear Box	014074	1	
10	Plate, Gear Box Spacer	014158-1	1	
11	Bolt, 3/8-16 x 1" Flat Socket Head	F05007-110	4	
12	Pulley, Up/Down	015256	1	
13	Key, 3/16" Square x 1" Long	S31027	1	
14	Bracket, Up/Down Motor Mount	015195-1	1	

15	WASHER, 8.4 FLAT	F81054-1	8	
16	WASHER, 8.2 SPLIT LOCK	F81054-4	4	
17	BOLT, 5/16-18 X 1" HEX HEAD	F05006-5	4	
18	WASHER, 10.5 SPLIT LOCK	F81055-1	4	
19	BOLT, 3/8-16 X 3/4" HEX HEAD	F05007-27	4	
	OIL, 8 OZ. MOBIL SHC634 BOTTLED SYNTHETIC GEAR	L04869-4	1	

SECTION 7 POWER FEED & TRACK ROLLERS

7.1 Upper Track Rollers And Wipers

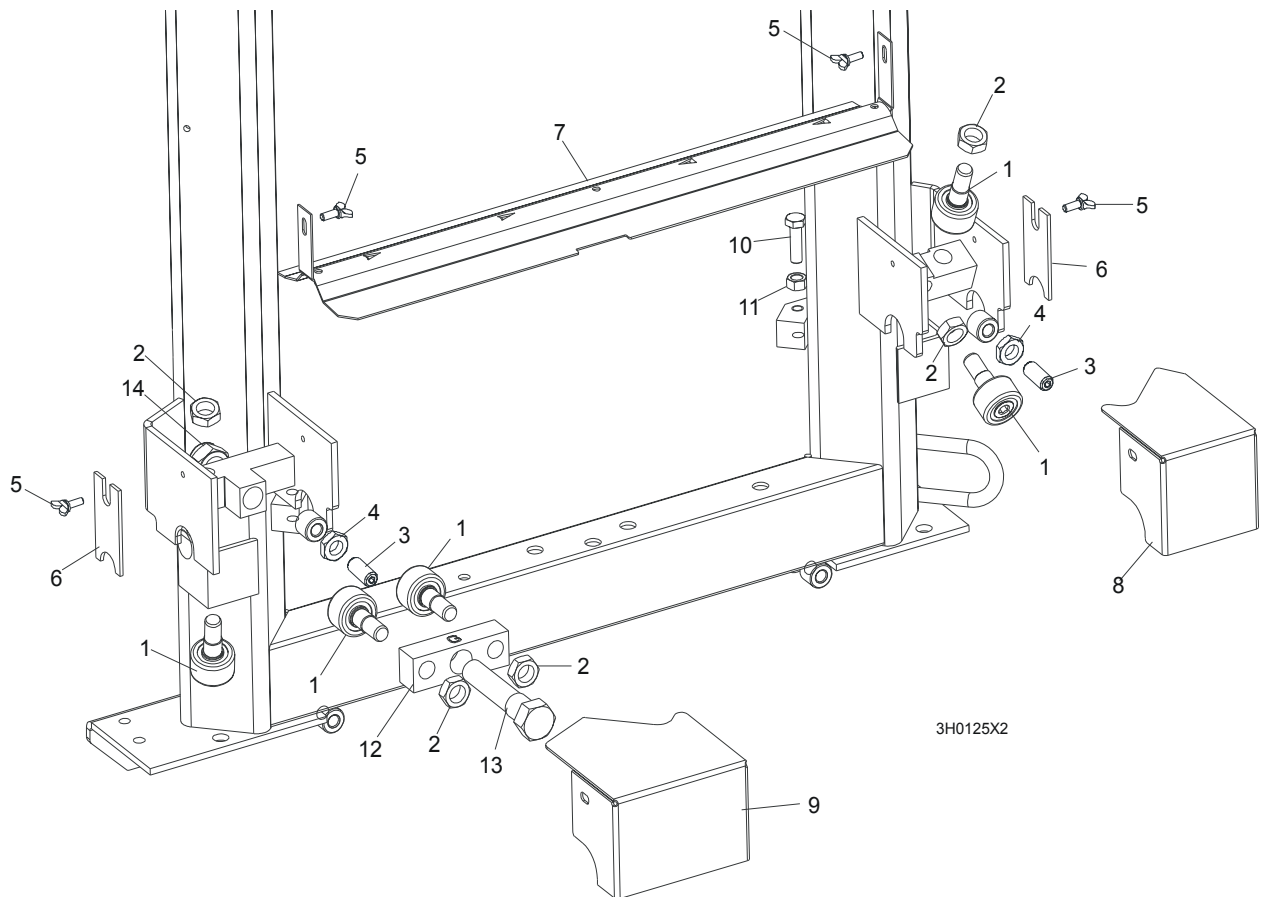

REF	DESCRIPTION (◆ Indicates Parts Available In Assemblies Only)	PART #	QTY.
1	ROLLER, TRACK CAM BEARING (MCGILL)	012797	5
2	NUT, 5/8-18 HEX JAM	F05010-11	5
3	SCREW, M12 X 30 OVAL POINT SET	F81004-14	2
4	NUT, M12-8-B HEX JAM	F81034-1	2
5	SCREW, M6 X 16 THUMB	F81001-16	4
6	WIPER, PLASTIC TRACK	M04113	2
7	COVER, MIDDLE TRACK OILER	S09917	1
	Wiper, Middle Track Felt	S09915	1
8	HOUSING, UPPER TRACK ROLLER REAR	086913-1	1
9	HOUSING, UPPER TRACK ROLLER FRONT	086914-1	1
10	BOLT, M10 X 35-8.8 HEX HEAD	F81003-17	2
11	NUT, M10-8 HEX JAM	F81033-3	2
12	BRACKET, UPPER TRACK ROLLER	086859-1	1
13	BOLT, HEX HEAD	086911	1
14	NUT, M20-8 HEX	F81037-2	1

7.2 Power Feed Assembly, LT30HD/LT40HD Super

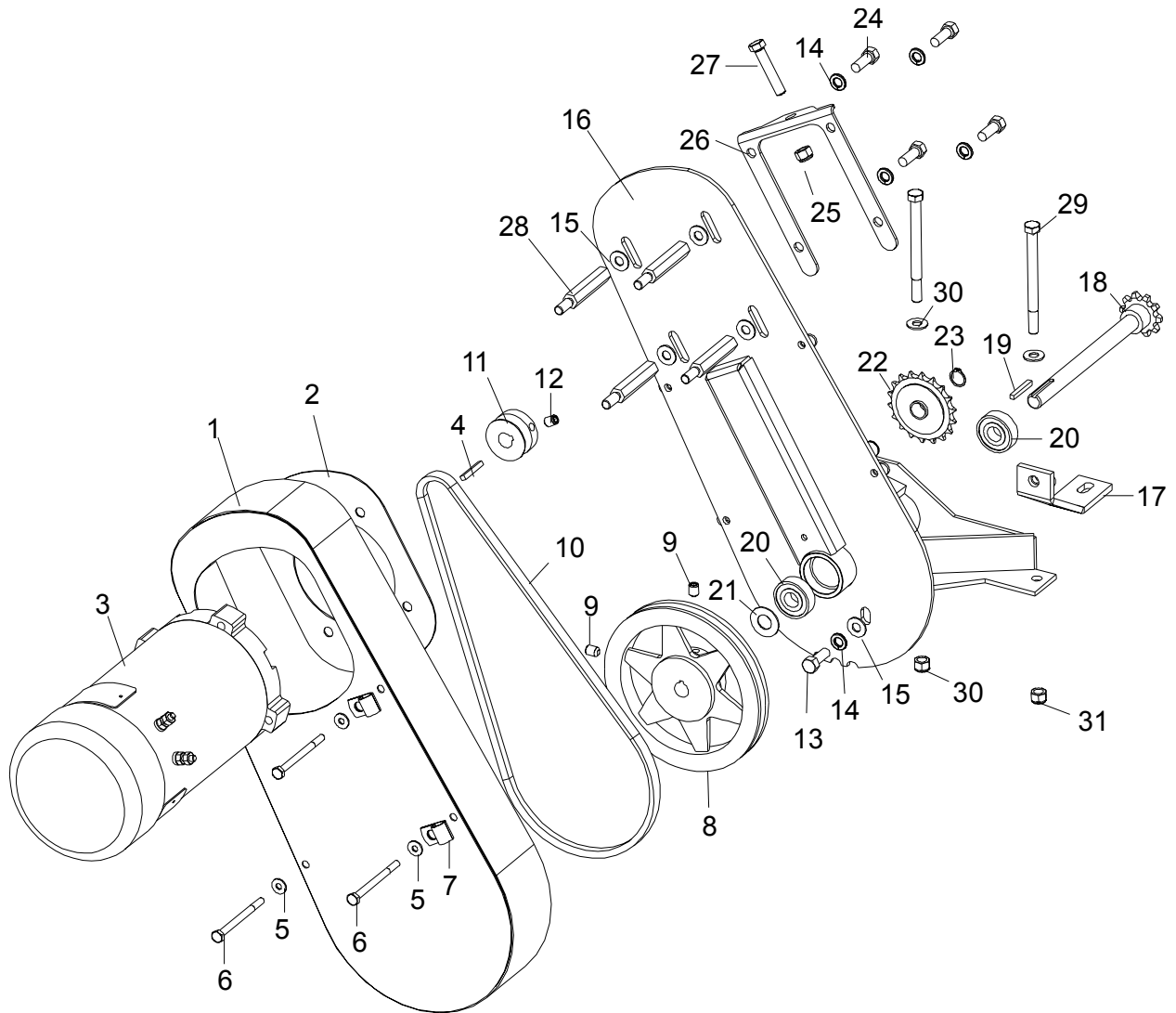

3H0619-2

REF	DESCRIPTION (◆ Indicates Parts Available In Assemblies Only)	PART #	QTY.
	POWER FEED ASSEMBLY	015125	1
1	Cover Weldment, Top Power Feed	015126	1
2	Plate, Power Feed Motor	015133	1
3	Motor, 3/4HP Power Feed Painted	024169	1
	Brush Kit, Leeson 3/4HP Motor (Includes 2 Brushes and 2 Springs)	024167	1
	Fan, 3/4 HP Leeson Motor Replacement	016087	1
4	Key, 3/16" Square x 1 3/8" Long	016109	1
5	Washer, 6.5 Flat	F81053-11	4
6	Bolt, M6x80 Hex Head Zinc	F81001-61	4

7

Power Feed & Track Rollers*Power Feed Assembly, LT30HD/LT40HD Super*

7	Clamp, 1/2" EMT Coated	P07584	2	
8	Sheave, AK71 x 5/8" Power Feed (200ft./min.)	016088 ¹	1	
9	Screw, 5/16-18 x 3/4" Cup Point Set	F05006-32	2	
10	Belt, AX36 (200ft./min.)	016083 ¹	1	
11	Sheave, 1 3/4" Feed Motor	015135	1	
12	Screw, 3/8"-16 x 1/2" Cup Point Set	F05007-12	1	
13	Bolt, M10x25-8.8 Hex Head Zinc	F81003-11	1	
14	Washer, 10.2 Split Lock	F81055-2	5	
15	Washer, 10.5 Flat	F81055-1	5	
16	Bracket, Power Feed Mount	015162-1	1	
17	Brace Weldment, Power Feed Mounting	086554-1	1	
	Shaft Assembly, Power Feed with Key	016066	1	
18	Shaft Weldment, Power Feed	015129	1	◆
19	Key, 3/16" Square x 1 3/8" Long	016108	1	
20	Bearing, 5/8" 6203-2NSL	P06030-1	2	
21	Washer, 5/8" x 15/16" x .094" Nylon	F05011-19	1	
22	Sprocket, 40 Idler 18T 5/8" ID	P04333	1	
23	Ring, Z15 Outer Retaining	F81090-2	1	
24	Bolt, 3/8-16 x 3/4" Hex Head	F05007-27	4	
25	Nut, 3/8-16 Hex Nylon Lock	F05010-10	1	
26	Plate, Belt Tensioner	015134	1	
27	Bolt, 3/8-16 x 2" Full Thread Hex Head	F05007-16	1	
28	Spacer, Power Feed Motor	015136	4	
29	BOLT, 3/8-16 X 4 1/2" HEX HEAD	F05007-35	2	
30	WASHER, 10.5 FLAT	F81055-1	4	
31	NUT, 3/8-16 HEX NYLON LOCK	F05010-10	2	

¹ Use kit 016085 to increase feed return rate to 220 ft./min. Kit includes AK64 sheave 016114, AX35 belt 015175, and instructions. Use kit 016070 to reduce feed return rate to 183 ft./min. Kit includes AL84 sheave 016115, AX38 belt 016068, and instructions.

7.3 Feed Chain/Stop, LT30HD/LT40HD Super

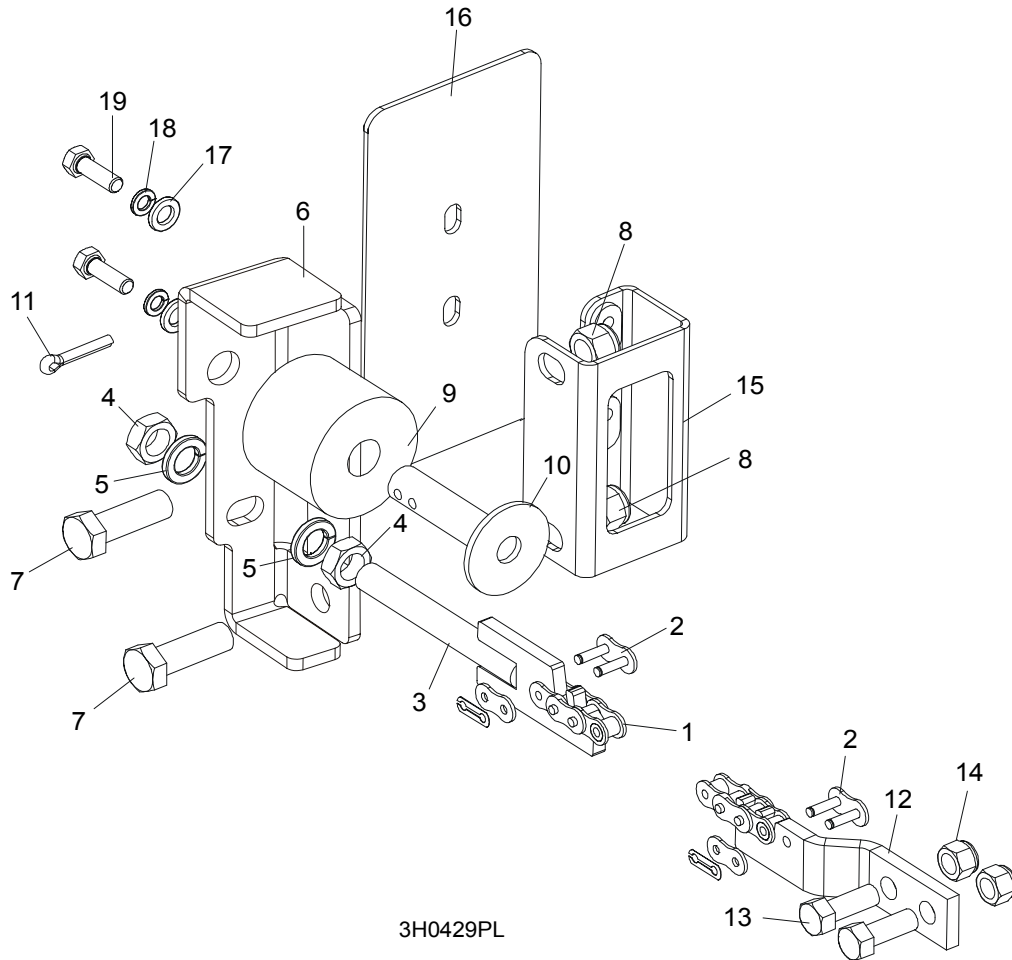

REF	DESCRIPTION (◆ Indicates Parts Available In Assemblies Only)	PART #	QTY.
	CHAIN KIT, LT30 FEED	K10408	1
	CHAIN KIT, LT40 FEED	K10410	1
1	Chain, #40 X 215" LT30 Feed	014744	1
	Chain, #40 X 267.5" LT40 Feed	014475	1
2	Link, #40 Master	P04200	2
3	Tensioner Weldment, Power Feed Chain	086818-1	1
4	Nut, M12-5 Hex Jam	F81034-4	2
5	Washer, 12.2 Split Lock	F81056-2	2
6	BRACKET, FEED CHAIN REAR MOUNT	087628-1	1
7	BOLT, M12 X 40 8.8 HEX HEAD GRADE 5	F81004-4	2
8	NUT, M12-8 HEX NYLON LOCK	F81034-2	2
	STOP KIT, RUBBER CARRIAGE	K09630	2
9	Stop, Rubber Carriage	P12165	1
10	Pin, Rubber Carriage Stop	W09293	1
11	Pin, 3/16" X 1" Cotter	F05012-21	1
12	BRACKET, FRONT FEED CHAIN MOUNT	015008	1

7**Power Feed & Track Rollers***Feed Chain/Stop, LT30HD/LT40HD Super*

13	BOLT, 3/8-16 X 1" HEX HEAD	F05007-7	2	
14	NUT, 3/8-16 HEX NYLON LOCK	F05010-10	2	
15	BRACKET WELDMENT, REAR MAIN TUBE COVER MOUNT	087105-1	1	
16	COVER, REAR MAIN TUBE	015023	1	
17	WASHER, 8.4 FLAT	F81054-1	2	
18	WASHER, 8.2 SPLIT LOCK	F81054-4	2	
19	BOLT, M8x25-8.8 HEX HEAD	F81002-5	2	

7.4 Lower Track Rollers

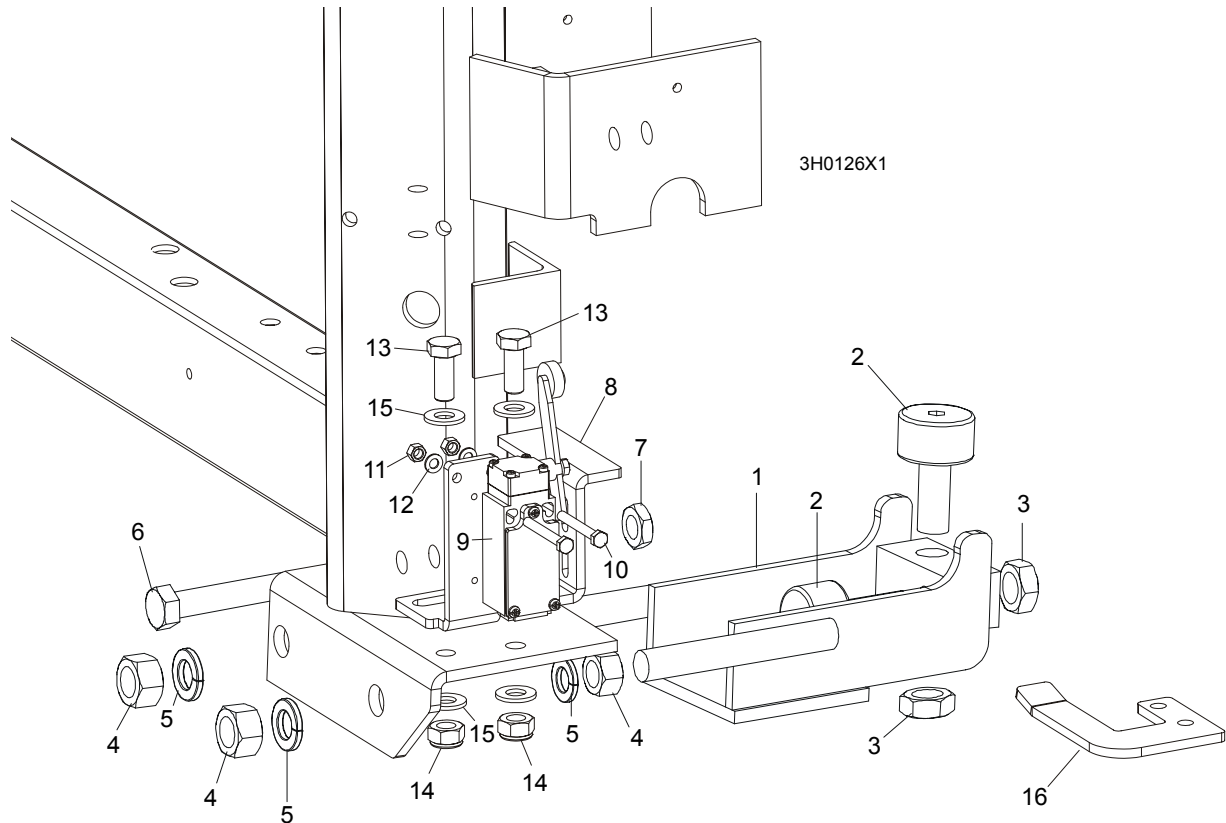

REF	DESCRIPTION (◆ Indicates Parts Available In Assemblies Only)	PART #	QTY.	
	ROLLER ASSEMBLY, LOWER TRACK	012995	2	
1	Bracket, Lower Track Roller Mounting	012982	1	◆
2	Roller, Track Cam Bearing (McGill)	012797	2	
3	Nut, 5/8-18 Hex Jam	F05010-11	2	
4	Nut, 5/8-11 Hex	F05010-5	4	
5	Washer, 16.3 Split Lock	F81058-2	4	
6	BOLT, M12 X 55-8.8 HEX HEAD FULL THREAD	F81004-12	2	
7	NUT, M12-8-B HEX JAM	F81034-1	2	
8	BRACKET, POWER SUPPLY STRIP AND LIMIT SWITCH	086380-1	1	
9	SWITCH, GLCB01A2B LIMIT	086469	1	
10	BOLT, M5 X 40 8.8 HEX HEAD	F810000-11	2	
11	NUT, M5-8	F81030-1	2	
12	WASHER, 5.3 FLAT	F81052-1	2	
13	BOLT, M10 X 25 8.8	F81003-11	2	
14	NUT, M10 NYLON	F81033-1	2	
15	WASHER, 10.5 FLAT	F81055-1	2	
16	BRACKET, LIMIT SWITCH	086473-1	1	

8 Bed Frame Assembly

Bed Rail Assembly, Front And Rear

SECTION 8 BED FRAME ASSEMBLY

8.1 Bed Rail Assembly, Front And Rear

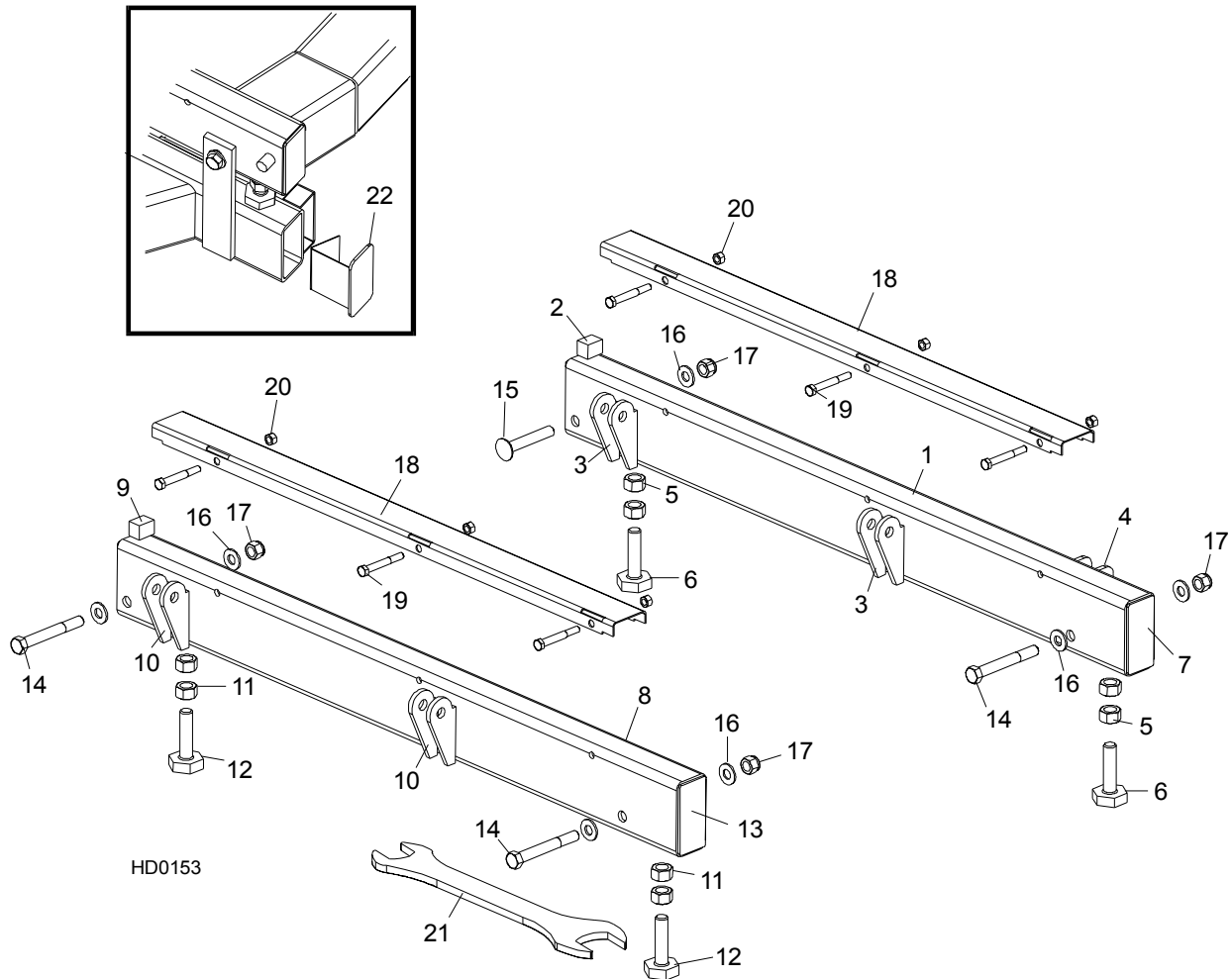

REF	DESCRIPTION (◆ Indicates Parts Available In Assemblies Only)	PART #	QTY.	
	BED RAIL ASSEMBLY, REAR PAINTED	014467	1	
1	Bed Rail Tube, Long	015974	1	◆
2	Block, Log Stop	S09034	1	
3	Bracket, Roller Toe Board Mount	S13021	4	◆
4	Bracket, Saw Head Rest Pin Mount	014150	2	◆
	Bolt Assembly, Bed Rail	086809	2	◆
5	Nut, 5/8-11 Hex	F05010-54	2	
6	Bolt, Bed Rail Adjustment	S13006	1	
7	Plate, Bed Rail End Cap	S04058	2	◆
	BED RAIL ASSEMBLY, FRONT PAINTED	014455	1	
8	Bed Rail Tube, Long	015974	1	◆
9	Block, Log Stop	S09034	1	
10	Bracket, Roller Toe Board Mount	S13021	4	◆

	Bolt Assembly, Bed Rail	086809	2	◆
11	Nut, 5/8-11 Hex	F05010-54	2	
12	Bolt, Bed Rail Adjustment	S13006	1	
13	Plate, Bed Rail End Cap	S04058	2	◆
14	BOLT, M12 X 100-8.8 HEX HEAD	F81004-3	3	
15	BOLT, 1/2-13 X 3 1/2" CARRIAGE	F05008-94 ¹	1	
16	WASHER, 13 FLAT	F81056-1	7	
17	NUT, M12-8 NYLON LOCK	F81034-2	4	
	COVER ASSEMBLY, STAINLESS STEEL BED RAIL (LONG)	A09956	2	
18	Cover, Stainless Steel Bed Rail	S09944	1	◆
19	Bolt, 5/16-18 X 2 1/2" Hex Head	F05006-10	3	
20	Nut, 5/16-18 Hex Lock	F05010-6	3	
21	WRENCH, BED RAIL ADJUSTMENT	015970	1	
22	CAP WELDMENT, BED RAIL REMOVABLE END	014652	2	

¹ Used on rear bed rail to allow clearance for side support rollers.

8

Bed Frame Assembly Bed Rail Assembly, Front Middle

8.2 Bed Rail Assembly, Front Middle

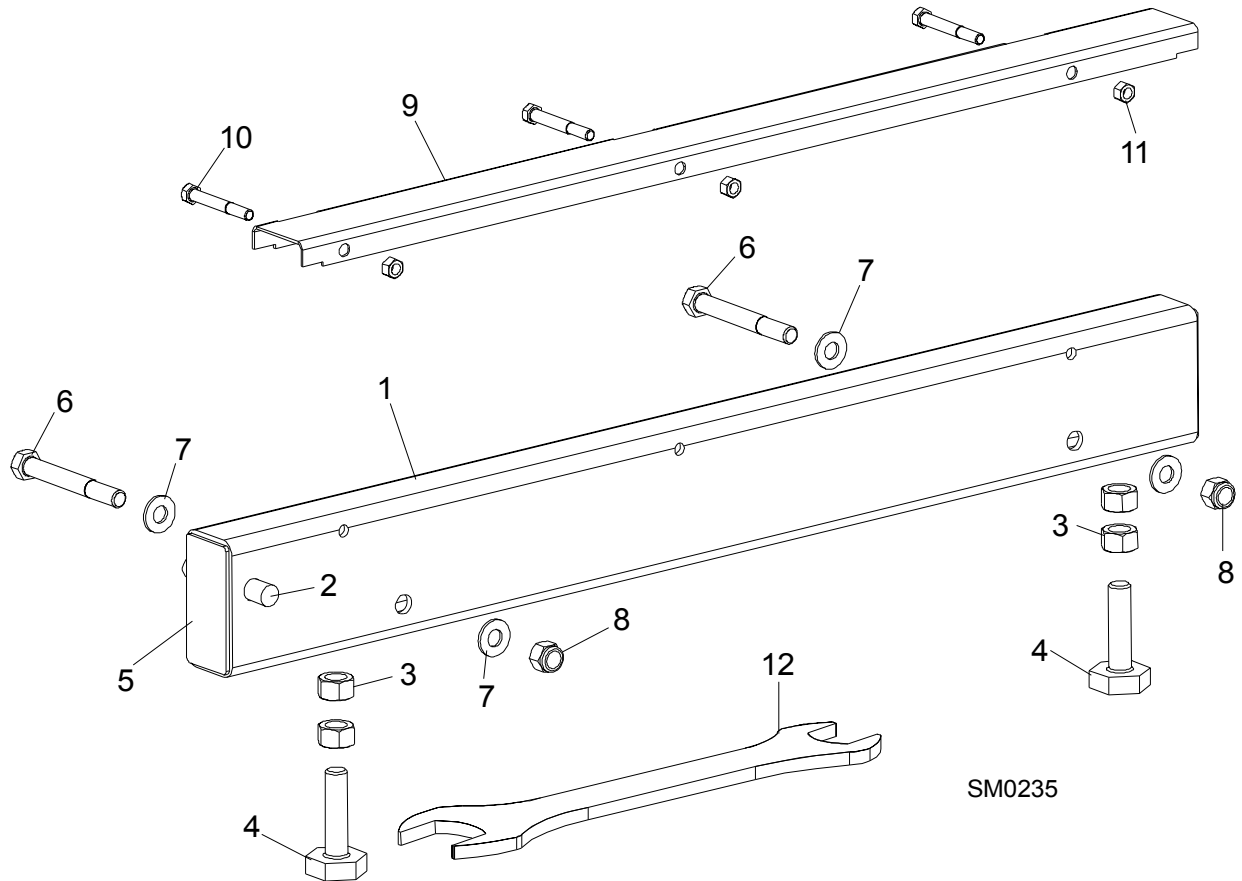

REF	DESCRIPTION (◆ Indicates Parts Available In Assemblies Only)	PART #	QTY.	
	BED RAIL ASSEMBLY, FRONT MIDDLE	A09566	1	
1	Bed Rail Tube, Short	S09103	1	◆
2	Pin, Ramp Mount	S04030	1	
	Bolt Assembly, Bed Rail	086809	2	◆
3	Nut, 5/8-11 Hex	F05010-54	2	
4	Bolt, Bed Rail Adjustment	S13006	2	
5	Plate, Bed Rail End Cap	S04058	2	◆
6	BOLT, M12 X 100-8.8 HEX HEAD	F81004-3	2	
7	WASHER, 13 FLAT	F81056-1	4	
8	NUT, M12-8 HEX NYLON LOCK	F81034-2	2	
	COVER ASSEMBLY, STAINLESS STEEL BED RAIL (LONG)	A09956	1	
9	Cover, Stainless Steel Bed Rail	S09944	1	◆
10	Bolt, M8x65-5,8 Zinc Hex Head	F81002-3	3	
11	Nut, M8-8-B-Zinc Hex Nylon Lock	F81032-2	3	
12	WRENCH, BED RAIL ADJUSTMENT	015970	1	

8.3 Bed Rail Assembly, Rear Middle

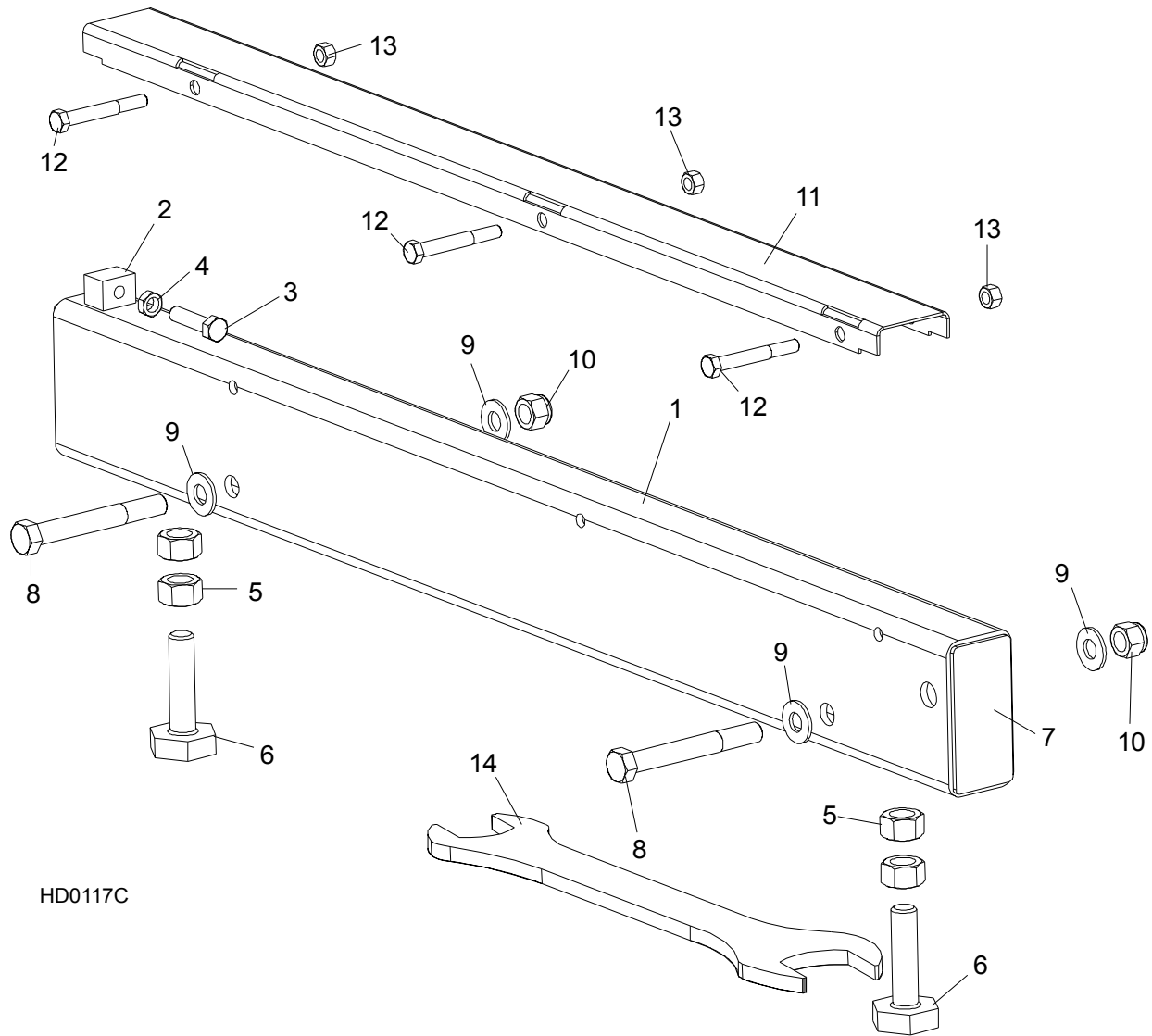

REF	DESCRIPTION (◆ Indicates Parts Available In Assemblies Only)	PART #	QTY.	
	BED RAIL ASSEMBLY, REAR MIDDLE PAINTED	015757	1	
1	Bed Rail Tube, Short	014640	1	◆
2	Block, Log Stop w/Threaded Hole	014639	1	◆
3	Bolt, 3/8-16 x 1 1/2 Full Thead Hex Head	F05007-17	1	
4	Nut, 3/8-16 Hex Jam	F05010-29	1	
	Bolt Assembly, Bed Rail	086809	2	◆
5	Nut, 5/8-11 Hex	F05010-54	2	
6	Bolt, Bed Rail Adjustment	S13006	2	
7	Plate, Bed Rail End Cap	S04058	2	◆
8	BOLT, M12 X 100-8.8 HEX HEAD	F81004-3	2	
9	WASHER, 13 FLAT	F81056-1	4	

8**Bed Frame Assembly***Bed Rail Assembly, Rear Middle*

10	NUT, M12-8 NYLON LOCK	F81034-2	2	
	COVER ASSEMBLY, STAINLESS STEEL BED RAIL (LONG)	A09956	1	
11	Cover, Stainless Steel Bed Rail	S09944	1	◆
12	Bolt, M8x65-5,8 Zinc Hex Head	F81002-3	3	
13	Nut, M8-8-B-Zinc Hex Nylon Lock	F81032-2	3	
14	WRENCH, BED RAIL ADJUSTMENT	015970	1	

8.4 Leg, Stationary

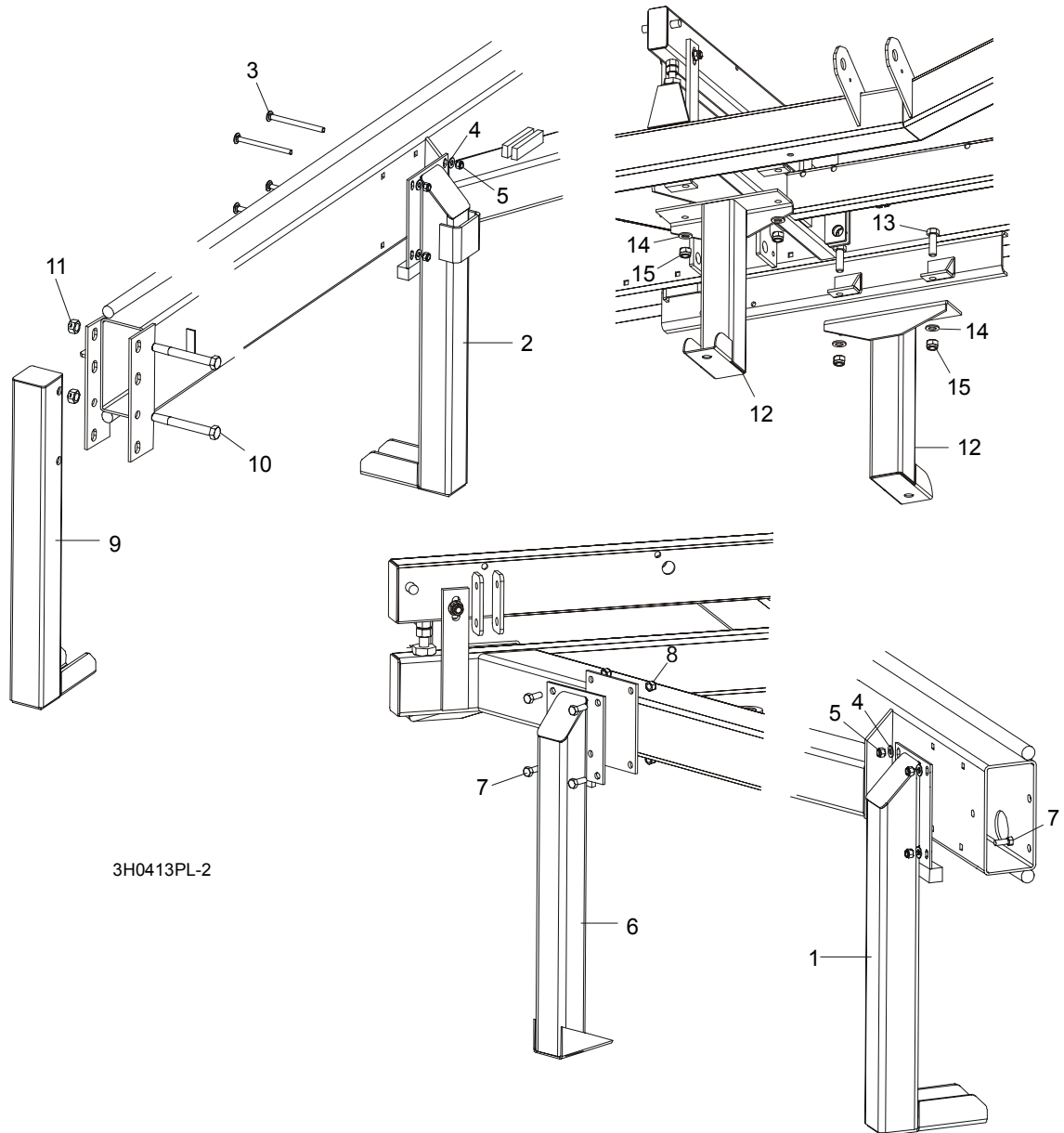

3H0413PL-2

REF	DESCRIPTION (◆ Indicates Parts Available In Assemblies Only)	PART #	QTY.
1	LEG, LONG RIGHT STATIONARY (1 REQ'D FOR LT30HD; 3 REQ'D FOR LT40HD)	087451-1	1/3
2	LEG, LONG STATIONARY W/BOARD RETURN TABLE BRACKET	087449-1	1
3	BOLT, M10 X 120-8.8 CARRIAGE HEAD	F81003-33	8/12
4	WASHER, 10.5 FLAT	F81055-1	8/16
5	NUT, M10-8-B HEX NYLON LOCK	F81033-1	8/16
6	LEG, SHORT LEFT STATIONARY	087450-1	2
7	BOLT, M10 X 25-8.8 HEX HEAD	F81003-11	12
8	NUT, M10-8-B HEX NYLON LOCK	F81033-1	12
9	LEG, FRONT STATIONARY	087452-1	1

8**Bed Frame Assembly***Leg, Stationary*

10	BOLT, M16 X 140-8.8 HEX HEAD GRADE 5	F81006-4	2	
11	NUT, M16-8 HEX LOCK	F81036-2	2	
12	LEG, MIDDLE STATIONARY	087093-1	2	
13	BOLT, M16 X 50-8.8 HEX HEAD	F81006-7	4	
14	WASHER, 17 FLAT	F81058-1	4	
15	NUT, M16 NYLON LOCK	F81036-2	4	

8.5 Board Return Table Assembly

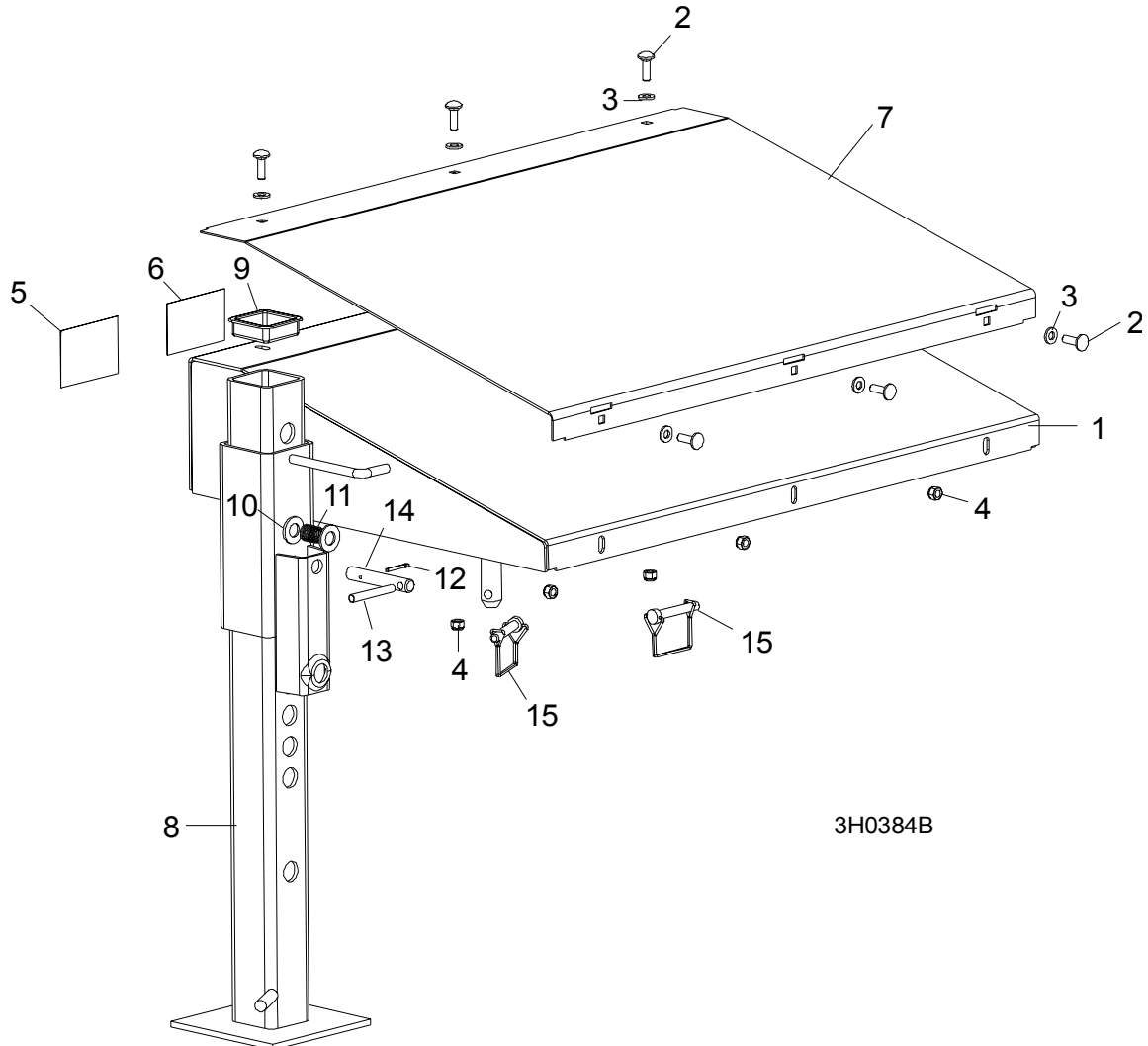

3H0384B

	DESCRIPTION (◆ Indicates Parts Available In Assemblies Only)	PART #	QTY.	
	TABLE ASSEMBLY, BOARD RETURN	015792	1	
1	Table Weldment, Board Return	015790	1	◆
2	Bolt, 5/16-18 x 1" Carriage Head	F81002-1	6	
3	Washer, 5/16" SAE Flat	F81032-2	6	
4	Nut, 5/16-18 Nylon Lock	F81054-1	6	
5	Decal, Board Return Danger	015365	1	
6	Decal, Board Return Table Warning	016077	1	
7	Plate, Return Table Stainless Steel	015791	1	
8	Leg Weldment, Painted Outrigger	W07537	1	
9	Cap, Outrigger Leg	P09926	1	
10	Washer, 9/16" SAE Flat	F81057-2	2	
11	Spring, .72 X 1.5 X .967" Diameter Stainless Steel Compression	P04282	1	
12	Pin, 1/8" X 1" Cotter	F05012-1	1	

8**Bed Frame Assembly***Board Return Table Assembly*

	Pin, Outrigger Pull Painted	S12260-0	1	
13	Pin, 5/16 x 2 1/2" Roll	F05012-47	1	
14	Pin, Outrigger Pull	S12260-0	1	
15	Pin, 3/8 X 2 1/4" Square Wire Lock	014151	2	

8.6 Pivot Bed Rail Assembly

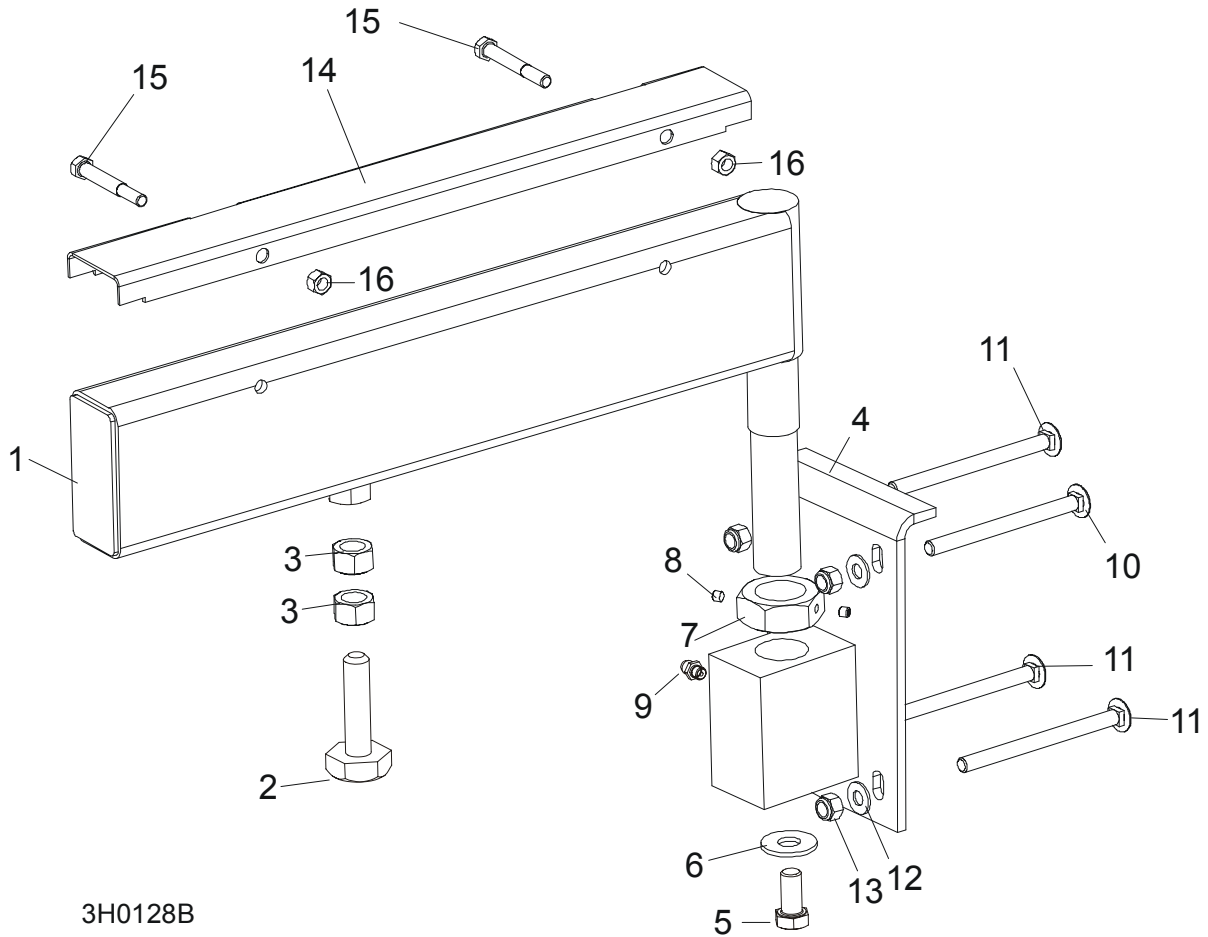

3H0128B

REF	DESCRIPTION (◆ Indicates Parts Available In Assemblies Only)	PART #	QTY.
	PIVOT BED RAIL ASSEMBLY (LT30HD)	087829	2
	PIVOT BED RAIL ASSEMBLY (LT40HD)	087855	2
1	Pivot Bed Rail Weldment (LT30HD)	087852	1
	Pivot Bed Rail Weldment (LT40HD)	087848	1
	Bolt Assembly, Bed Rail Adjustment		1
2	Bolt, Bed Rail Adjustment	086809	1
3	Nut, 5/8-11 Hex	F81036-1	2
4	Bracket, Pivot Rail Mounting	087841-1	1
5	Bolt, 1/2-13 x 1" Hex Head Grade 2	F81004-31	1
6	Washer, 15 Flat	F05011-52	1
7	Nut, Pivot Rail Adjustment (LT30HD) Nut, Pivot Rail Adjustment (LT40HD)	F81036-1 F81039-2	1
8	Screw, 1/4-28 x 1/4" Brass Tip Set	F05005-42	2
9	Fitting, 3/16" Grease	086280	1
10	BOLT, 3M10 X 120-8.8 CARRIAGE HEAD	F81003-14	2
11	BOLT, 3/8-16 X 5" CARRIAGE HEAD	F05007-113	6

8

Bed Frame Assembly*Pivot Bed Rail Assembly*

12	WASHER,10.5 FLAT	F81055-1	8	
13	NUT, M16-8 NYLON LOCK	F81036-2	8	
	COVER KIT, PIVOT RAIL STAINLESS STEEL (LT30HD)	015926	2	
	COVER KIT, PIVOT RAIL STAINLESS STEEL (LT40HD)	N/A	2	
14	Cover, Stainless Steel Pivot Bed Rail (LT30HD)	012994	1	
	Cover, Stainless Steel Pivot Bed Rail (LT40HD)	S13012	1	
15	Bolt, M8x65-5,8 Zinc Hex Head	F81002-3	4	
16	Nut, M8-8-B-Zinc Hex Nylon Lock	F81032-2	4	
	WRENCH, BED RAIL ADJUSTMENT (See Section 8.3)	015970	1	

8.7 Log Side Support Assembly (Manual)

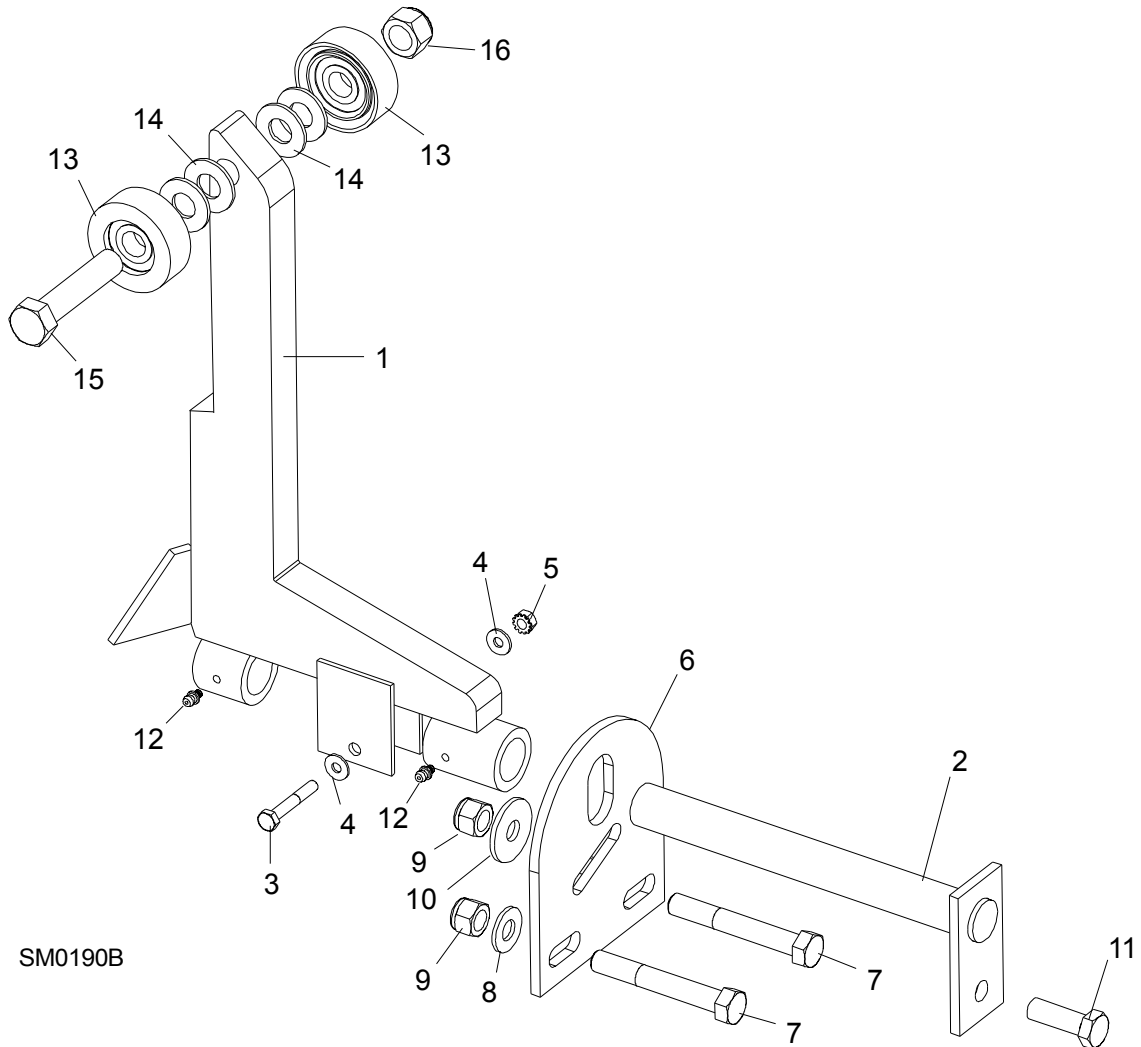

[See Section 9.6](#) for hydraulic side supports...

REF	DESCRIPTION (◆ Indicates Parts Available In Assemblies Only)	PART #	QTY.
1	SUPPORT, LOG SIDE	085538	2
	MOUNTING KIT, LOG SIDE SUPPORT	K09440	2
2	Pin, Log Side Support Pivot	W09238-1	1
3	Bolt, 1/4-20 X 1 1/2" Hex Head Grade 5	F05005-4	1
4	Washer, 7.4 Flat	F81056-11	2
5	Nut, 1/4-20 Self Locking	F05010-9	1
6	Plate, Log Side Support End	S09148	1
7	Bolt, M12 x 90-8.8 Hex Head	F81004-2	2
8	Washer, 13 Flat	F81056-1	2
9	Nut, M12-8 Hex Nylon Lock	F81034-2	3
10	Washer, .5" x 1.63" x 11" Ga.	086184	1

8

Bed Frame Assembly*Log Side Support Assembly (Manual)*

11	Bolt, M12 x 35-8.8 Hex Head	F81004-11	1	
12	FITTING, 3/16" GREASE	P04107	2	
	ROLLER KIT, SIDE SUPPORT (OPTIONAL)	015109	4	
13	Roller Assembly, Side Support	015014-1	2	
14	Washer, 17 Flat	F81058-1	4	
15	Bolt, 5/8-11 x 3" Hex Head Grade 5	F05009-37	1	
16	Nut, 5/8-11 Nylon Lock	F05010-34	1	
	Instruction Sheet, Side Support Roller	015109-526	1	

8.8 Tie Down Chain Assembly

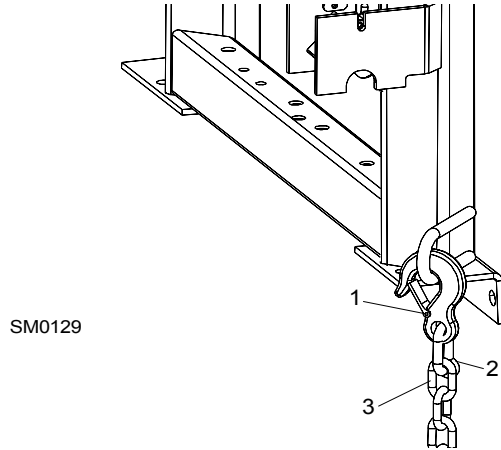

REF	DESCRIPTION (◆ Indicates Parts Available In Assemblies Only)	PART #	QTY.	
	CHAIN ASSEMBLY, TIE DOWN	A04376	1	
1	Hook, 5/8" Safety Chain	P12075	1	◆
2	Cold Shut, 3/8" Plain	P04772-2	1	◆
3	Chain, N-10 x 35 Unplated	R80558	.28 m	◆

8 **Bed Frame Assembly**
Saw Head Rest Pin Assembly

8.9 Saw Head Rest Pin Assembly

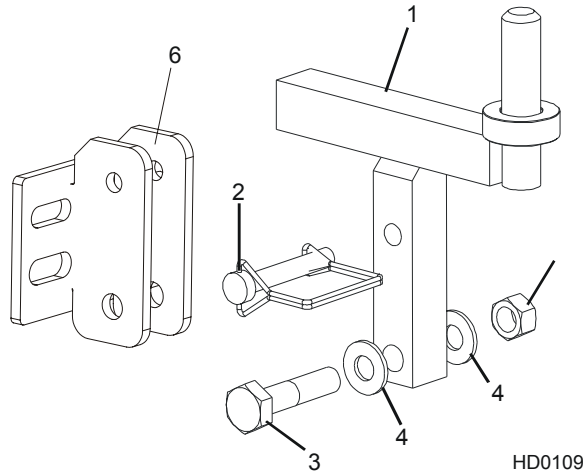

REF	DESCRIPTION (◆ Indicates Parts Available In Assemblies Only)	PART #	QTY.
1	PIN, SAW HEAD REST	085949	1
2	PIN, 3/8" X 2 1/4" SNAP RETAINER	014151	1
3	BOLT, M12 X 60-8.8 HEX HEAD GRADE 5	F81004-5	1
4	WASHER, 13 SAE FLAT	F81056-1	2
5	NUT, 1/2-13 HEX LOCK	F05010-3	1
6	GRIP, SAW HEAD REST	092765-1	1

8.10 Bed Frame Decals

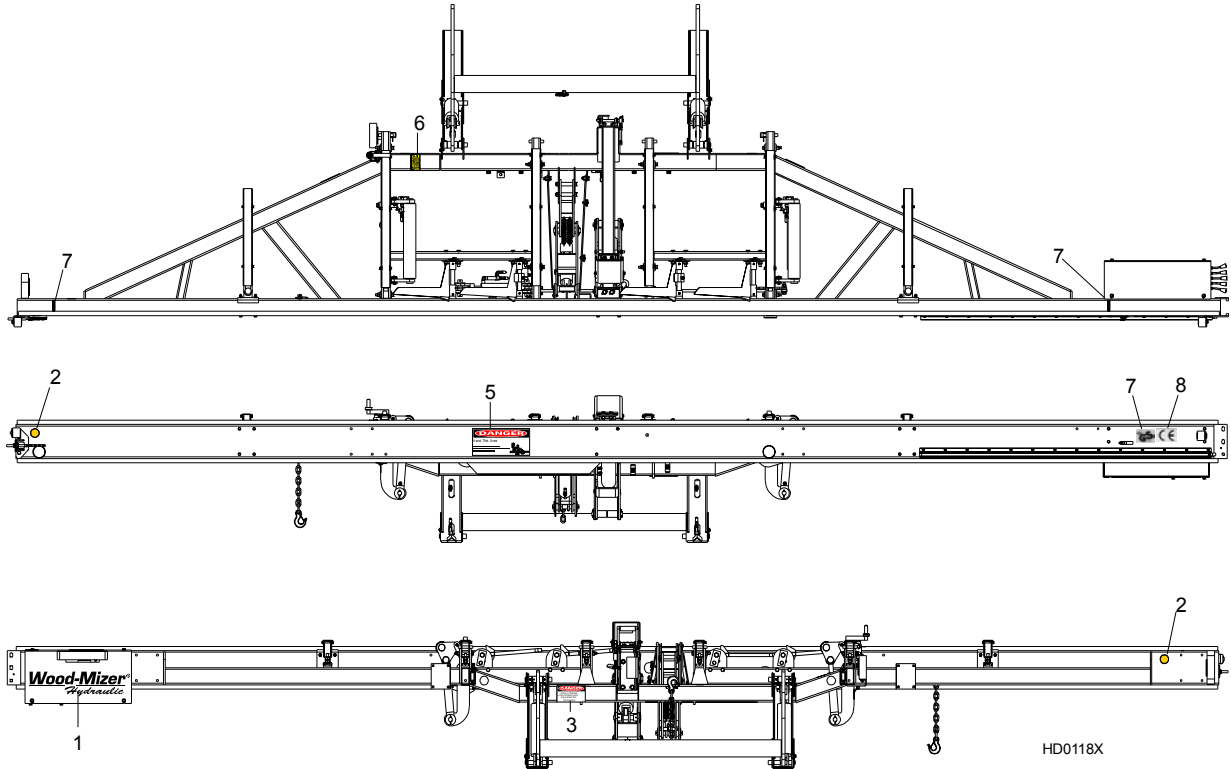

REF	DESCRIPTION (◆ Indicates Parts Available In Assemblies Only)	PART #	QTY.
1	DECAL, WOOD-MIZER SUPER HYDRAULIC LOGO	014168	1
2	DECAL, AMBER REFLECTIVE 2" ROUND	P07453	2
3	DECAL, KEEP AWAY DANGER	S09851	1
4	DECAL, PINCH POINT DANGER	P10287	1
5	DECAL, SAW HEAD REST CAUTION	S12581	1
6	DECAL, LOG LIMIT STRIPE	S12051	2
7	DECAL, GS SAFETY CERTIFICATION, SMALL	P85072	1
8	DECAL, CE CERTIFIED SAWMILL, SMALL	P85070	1

SECTION 9 HYDRAULIC SYSTEM

9.1 Hydraulic Hoses

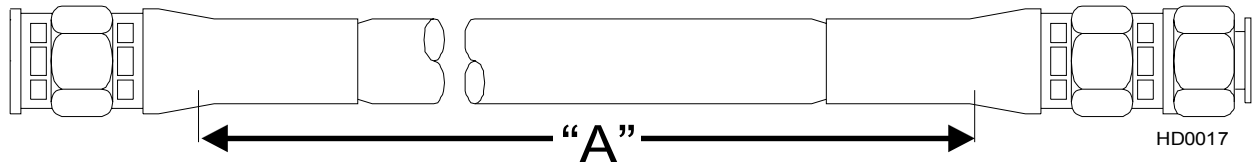

COLOR	LENGTH "A"	DESCRIPTION (◆ Indicates Parts Available In Assemblies Only)	PART #	QTY.
None	18"	1/4" HYDRAULIC PUMP TO VALVE	015704	2
Plain	27"	3/8" LOG TURNER CYLINDER BASE	014796	1
Orange	18"	3/8" LOG TURNER CYLINDER TOP	014795	1
Yellow	99"	1/4" FRONT TOE BOARD TOP (LT30HD SUPER)	014783	1
	121"	1/4" FRONT TOE BOARD TOP (LT40HD SUPER)	014784	1
Gray	99"	1/4" FRONT TOE BOARD BASE (LT30HD SUPER)	014783	1
	121"	1/4" FRONT TOE BOARD BASE (LT40HD SUPER)	014784	1
Plain	160"	3/8" SIDE SUPPORT CYLINDER TOP (LT30HD SUPER)	015686	1
	182"	3/8" SIDE SUPPORT CYLINDER TOP (LT40HD SUPER)	015689	1
Pink	168"	3/8" SIDE SUPPORT CYLINDER BASE (LT30HD SUPER)	015688	1
	190"	3/8" SIDE SUPPORT CYLINDER BASE (LT40HD SUPER)	015691	1
White	139"	3/8" CLAMP CYLINDER TOP (LT30HD SUPER)	015683	1
	151"	3/8" CLAMP CYLINDER TOP (LT40HD SUPER)	015685	1
Dark Orange	123"	3/8" CLAMP CYLINDER BASE (LT30HD SUPER)	014799	1
	145"	3/8" CLAMP CYLINDER BASE (LT40HD SUPER)	015684	1
Purple	203"	1/4" REAR TOE BOARD TOP (LT30HD SUPER)	014792	1
	225"	1/4" REAR TOE BOARD TOP (LT40HD SUPER)	014794	1
Black	203"	1/4" REAR TOE BOARD BASE (LT30HD SUPER)	014792	1
	225"	1/4" REAR TOE BOARD BASE (LT40HD SUPER)	014794	1
Green	62"	3/8" LOADING ARM BRANCH TOP	014797	2
Yellow	63"	3/8" LOADING ARM BRANCH BASE	014798	2
Blue	165"	3/8" LOADING ARM CYLINDER TOP (LT30HD SUPER)	015687	1
	187"	3/8" LOADING ARM CYLINDER TOP (LT40HD SUPER)	015690	1
Red	165"	3/8" LOADING ARM CYLINDER BOTTOM (LT30HD SUPER)	015687	1
	187"	3/8" LOADING ARM CYLINDER BOTTOM (LT40HD SUPER)	015690	1
Green	174"	1/4" CLAMP UP (LT30HD SUPER)	014787	1
	196"	1/4" CLAMP UP (LT40HD SUPER)	014791	1
Yellow	174"	1/4" CLAMP DOWN (LT30HD SUPER)	014787	1
	196"	1/4" CLAMP DOWN (LT40HD SUPER)	014791	1

9.2 Hydraulic Control Box

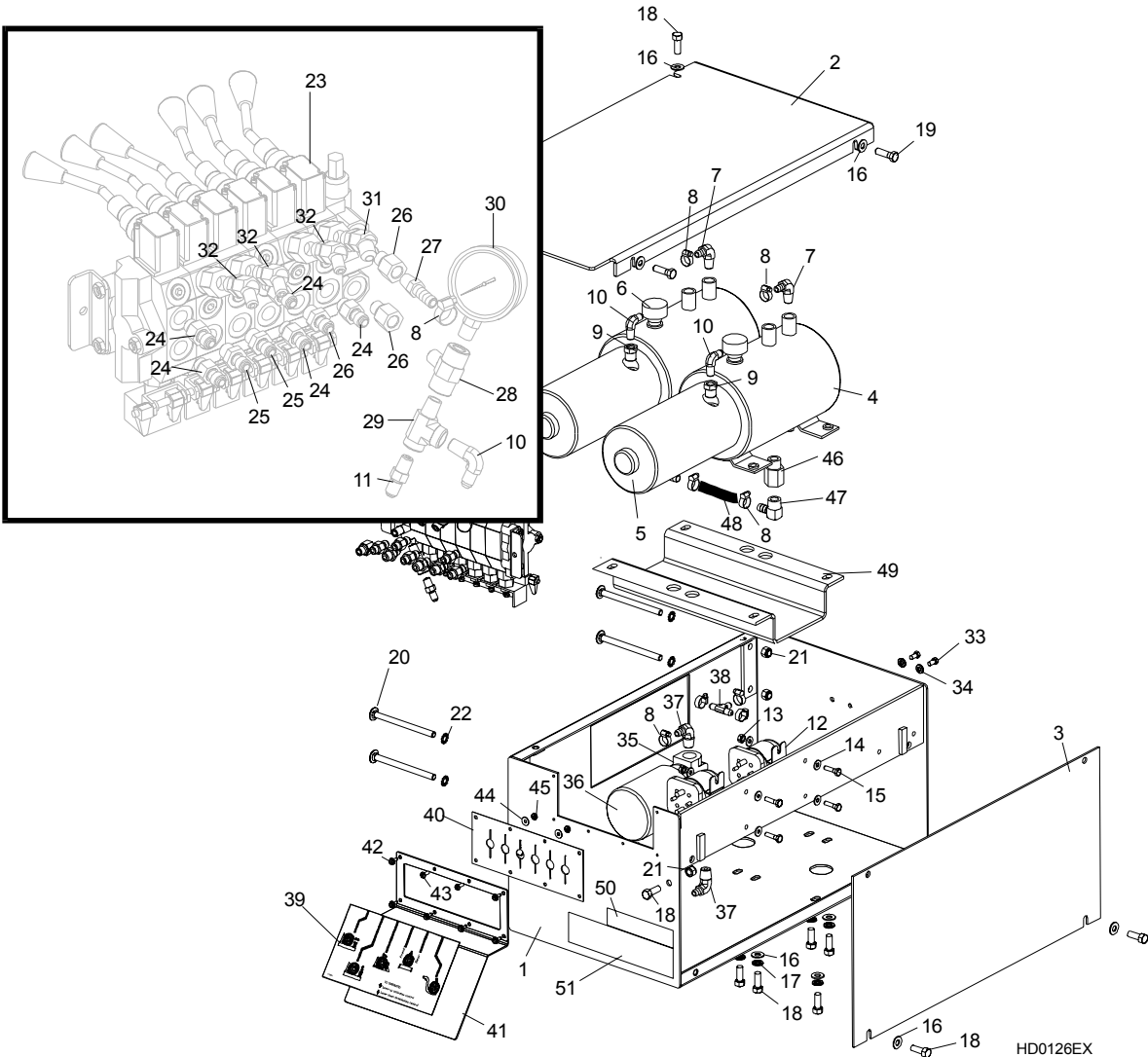

REF	DESCRIPTION (◆ Indicates Parts Available In Assemblies Only)	PART #	QTY.
1	BOX WELDMENT, SUPER HYDRAULIC PUMP HOUSING	015027-1	1
2	COVER, SUPER HYDRAULIC PUMP HOUSING TOP	086203	1
3	COVER, SUPER HYDRAULIC PUMP HOUSING SIDE	015227	1
4	PUMP W/MOTOR, HYDRAULIC #M-300-0230	P12701	2
5	Motor, 12 VDC Hydraulic Pump #08058	P09955	1
	Brush Kit, 4-Valve Hydraulic Pump Motor #08658	P09585	1
	Bearing, Base Motor #02318	P12513	1
6	Cap, Hydraulic Pump Vented Fill #03171	P12817	1
	O-Ring, Hydraulic Pump/Reservoir #02352	P10198	1
	Seal, Hydraulic Pump/Motor #02330	P10315	1
7	FITTING, #6-6 (3/8" NPT) - 3/8" HOSE BARB ELBOW	P12708	2
8	CLAMP, 11/16" HOSE	P12739	10

9

Hydraulic System Hydraulic Control Box

9	FITTING, 3/8" NPT - 1/4" NPT REDUCER	015490	2	
10	FITTING, 1/4" NPT - 1/4" JIC ELBOW	P09142	3	
11	FITTING, 1/4" NPT - 1/4" JIC	P09143	1	
12	SOLENOID, 200A 12V SPST HYDRAULIC PUMP MOTOR	015470	2	
13	NUT, #1/4-20 SELF LOCKING	F05010-9	4	
14	WASHER, 7.4 FLAT	F81056-11	8	
15	BOLT, #1/4-20 X 1" HEX HEAD	F05005-38	4	
	FLUID, 1-QUART DEXRON III HYDRAULIC	P12742	8.5 l	
	FLUID, 1-GALLON EXXON UNIVIS J26 HYDRAULIC	P12824	8.5 l	
	FLUID, 1-GALLON EXXON UNIVIS P13 HYDRAULIC	P12822	8.5 l	
	DECAL, HYDRAULIC FLUID REPLACEMENT	S12825	1	
16	WASHER, 10.5 FLAT	F81055-1	14	
17	WASHER, 10.2 SPLIT LOCK	F81055-2	8	
18	BOLT, 3/8-16 X 1" HEX HEAD	F05007-7	14	
19	BOLT, 3/8-16 X 1 1/4" HEX HEAD	F05007-2	2	
20	BOLT, 3/8-16 X 5" CARRIAGE HEAD	F05007-113	4	
21	WASHER, 3/8" EXTERNAL STAR LOCK	F05011-36	4	
22	NUT, 3/8-16 HEX NYLON LOCK	F05010-10	6	
23	VALVE, HYDRAULIC 6 SECTION (See Form 575 FOR VALVE SERVICE PARTS)	015260	1	
	SWITCH, HYDRAULIC VALVE ELECTRIC	014765	1	
24	FITTING, 3/8" O-RING - 3/8" JIC	014687	5	
25	FITTING, 3/8" O-RING - 1/4" JIC	P26284	3	
26	FITTING, #6 SAE MALE - 1/4" NPT FEMALE	014686	2	
27	FITTING, 1/4" NPT X 3/8" HOSE BARB	014685	1	
28	FITTING, 1/4" NPT BRANCH T	015486	1	
29	FITTING, 1/4" NPT - 1/4" JIC MALE RUN T	P09141	1	
30	GAUGE, 5000 PSI HYDRAULIC	P10052	1	
31	FITTING, #6 SAE - 3/8" JIC 45° ELBOW	015489	1	
32	FITTING, #6 SAE - 1/4" JIC 45° ELBOW	015488	3	
33	BOLT, 1/4-20 X 1/2" HEX HEAD	F05005-15	2	
34	WASHER, 6.1 SPLIT LOCK	F81053-3	2	
35	MANIFOLD, HYDRAULIC CARTRIDGE FILTER	P22683	1	
36	Filter, S28 Hydraulic Cartridge	P20301	1	
37	FITTING, #6-8 (1/2" NPT) - 3/8" HOSE BARB ELBOW	P12707	2	
38	FITTING, 3/8" HOSE BARB T	015485	1	
39	DECAL, 1997 SUPER HYDRAULIC CONTROL BOX	015364	1	
	HOSE, 3/8" LOW PRESSURE HYDRAULIC	R01892-1	A/R	
40	SEAL, RUBBER VALVE HANDLE	015079	1	
41	PLATE, VALVE HANDLE DECAL	015078	1	
42	SCREW, #10 X 1/2 SLOTTED HEX SELF-TAPPING	F05015-7	6	
43	SCREW, #10-24 X 1/2" SLOTTED HEX HEAD	F05015-4	2	
44	WASHER, 5.3 FLAT	F81052-1	2	
45	NUT, #10-24 SELF-LOCKING HEX	F05010-14	2	
46	FITTING, 1/2" NPT - 1/2" NPT ADAPTOR	015995	2	
47	FITTING, 1/2" NPT - 1/2" HOSE BARB 90° ELBOW	015997	2	
48	HOSE, 1/2" ID HYDRAULIC LOW PRESSURE	R02133	.15 m	

49	GUARD, HYDRAULIC CROSSOVER	015992	1	
	GROUNDING ASSEMBLY, HYDRAULIC PUMP	N/A	1	
	Bolt, 3/8-16 x 1/2" Hex Head Grade 5	F05004-124	2	
	Cable, 1AWG SO Welding	R01971	1 I	
	Terminal, 5/16 1-2Gauge Ring NI Loose	F05092-16	4	
	Washer, 3/8" Star External	F05011-36	3	
50	DECAL, HYDRAULIC WORKING PRESSURE	P85069	1	
51	DECAL, HYDRAULIC FLUID	P85068	1	

9.3 Hydraulic Power Supply Strip

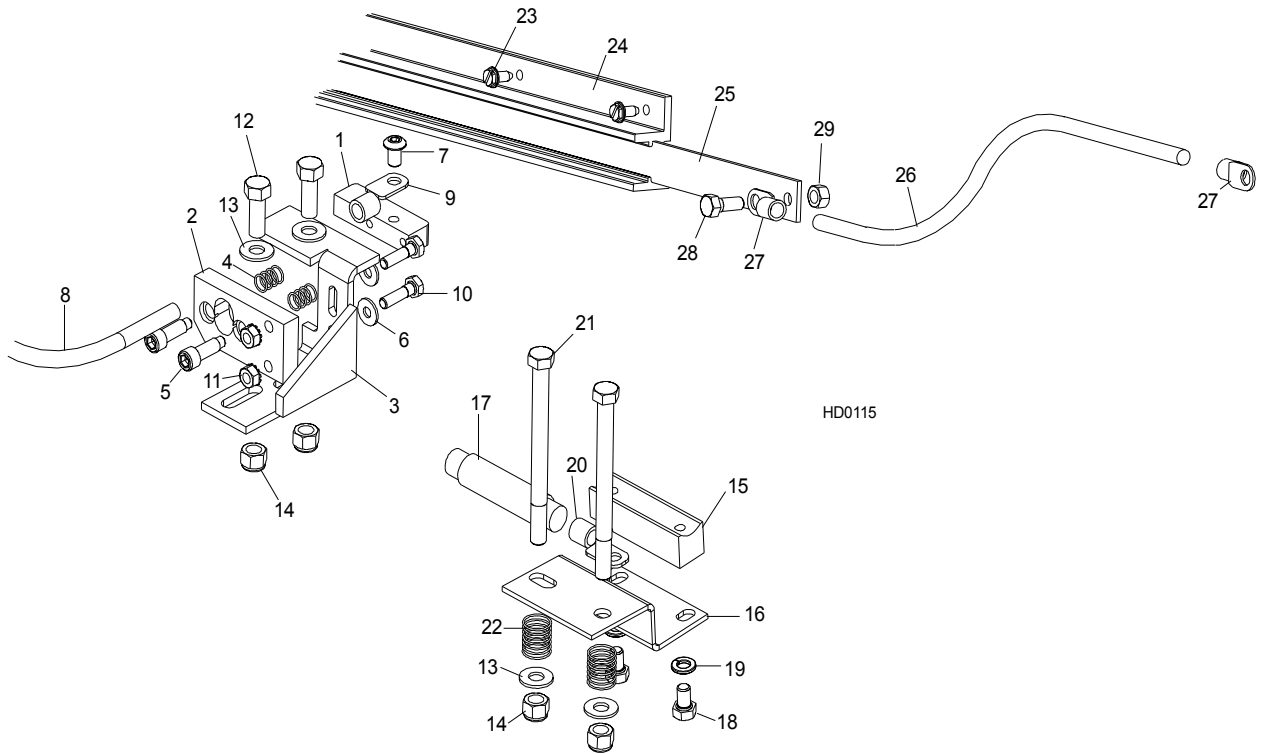

REF	DESCRIPTION (◆ Indicates Parts Available In Assemblies Only)	PART #	QTY.	
	CONTACT ASSEMBLY, HYDRAULIC POWER SUPPLY (POSITIVE)	085968	1	
1	Contact, Hydraulic Power Supply (Positive)	015253	1	
2	Insulator, Positive Contact	S10072	1	
3	Bracket, Positive Contact Mounting	086380-1	1	
4	Spring, Positive Contact	P10077	2	
5	Bolt, 5/16" X 3/4" Shoulder (1/4-20 Thread)	F05006-44	2	
6	Washer, 7.4 Flat	F81056-11	2	
7	Bolt, 5/16-18 x 1/2" Socket Button Head	F05006-20	1	
8	Cable, H07V-K BK 1x50	R80591-1	0.7m	◆
9	Terminal, KO50/8	F81067-2	2	
10	Bolt, 1/4-20 X 1" Hex Head Grade 2	F05005-38	2	
11	Nut, 1/4-20 Hex Self-Locking	F05010-9	2	
12	Bolt, 3/8-16 X 1" Hex Head Grade 5	F05007-87	2	
13	Washer, 10.5 Flat	F81055-1	4	
14	Nut, 3/8-16 Hex Nylon Lock	F05010-10	4	
	CONTACT ASSEMBLY, HYDRAULIC POWER SUPPLY (GROUND)	A10066	1	
15	Contact, Hydraulic Power Supply (Ground)	015264	1	
16	Bracket, Ground Contact Mounting	090254-1	1	
17	Cable, H07V-K BK 1x50	R80591	.76m	◆

18	Bolt, 5/16-18 X 1/2" Hex Head Grade 5	F05006-15	2	
19	Washer, 8.2 Split Lock	F81054-4	2	
20	Terminal, KO50/8	F81067-2	1	
21	Bolt, 3/8-16 X 4 1/2" Hex Head Grade 2	F05007-35	2	
22	Spring, Ground Contact	P04282	2	
23	Screw, 1/4-20 X 1/2" Slotted Hex Head	F05015-1	14	
	STRIP ASSEMBLY, HYDRAULIC POWER SUPPLY ,SUPER97 SAWMILL	015564-0	1	
24	Housing, Contact Strip	086685	1	
25	Strip, Contact	086686	1	◆
26	Cable, H07V-K BK 1x50	R80591-1	1,9m	◆
27	Terminal, KO50/8	F81067-2	4	
28	Bolt, 5/16-18 X 3/4" Hex Head Black Nylon	F05006-45	1	
29	Nut, 5/16-18 Hex Black Nylon	F05010-86	1	
	Tube, RC19/9,5 Heat Shrink Black	R80600-3	.14 m	◆
	Grommet, HEYCO Wire	P04137	2	

9.4 Hydraulic Log Loader

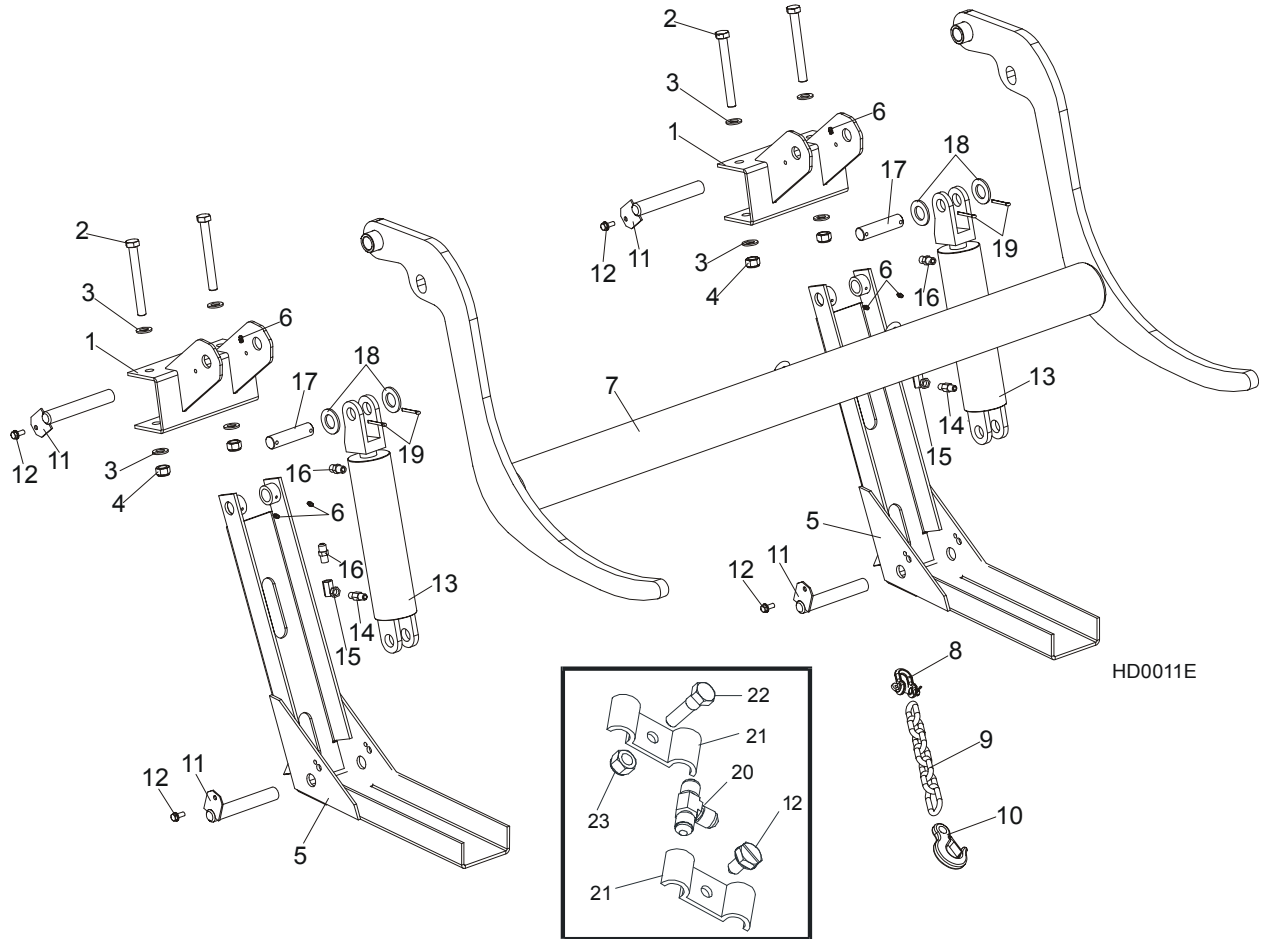

REF	DESCRIPTION (◆ Indicates Parts Available In Assemblies Only)	PART #	QTY.
	LADOWARKA KŁODY - DWURAMIENNA, KPL.	092863	1
1	Uchwyt ładowarki	092865-1	1
2	Bolt, M16X140MM, Hex Head, Grade 8.8 Zinc	F81006-4	4
3	Washer, M16, Flat Zinc	F81058-1	8
4	Nut, M16, Hex, Nylon Zinc Lock	F81036-2	4
5	Channel, Hydraulic Log Loading Foot Complete	090049	2
5	Channel, Hydraulic Log Loading Foot	090048-1	2
6	Fitting, 3/16x3/16 Straight Grease	P04107	6
7	Arm, Hydraulic Log Loading Complete	090044	1
7	Arm, Hydraulic Log Loading	090006-1	1
8	Szakła M-D WL. 0,63 PN-92/w-89180	086540	1
9	Chain, Hydraulic Log Loader Safety	090007-1	1
10	Hook, 5/8 Safety Chain	P12075	1
11	Pin, Turner Arm	W09446-1	4
12	Bolt, 5/16-18x3/4 Self Tap	F05015-30	4

13	Cylinder Assy, Log Loading Super	015562	2	
14	Fitting, 1/4NPT Velocity Fuse 5.0GPM	015750	2	
15	Fitting, 1/4NPT-1/4JIC Swivel Elbow	P12199	2	
16	Fitting, 3/8JIC-1/4NPT Str	015560	4	
17	Washer, 28 Fe/Zn5	F81061-1	4	
18	Fitting, 1/4JIC Union Tee	P09145	2	
19	Fitting, 3/8 Barb Tee	015485	1	
20	Plate, 1/4 Hose Clamp Ptd	S09245	6	
21	Clamp, 3/8 Hose	016041	2	
22	Bolt, 5/16-18x1 HH	F05006-1	1	
23	Nut, 5/16-18 Nylon Lock	F05010-58	1	

9.5 Hydraulic Log Turner

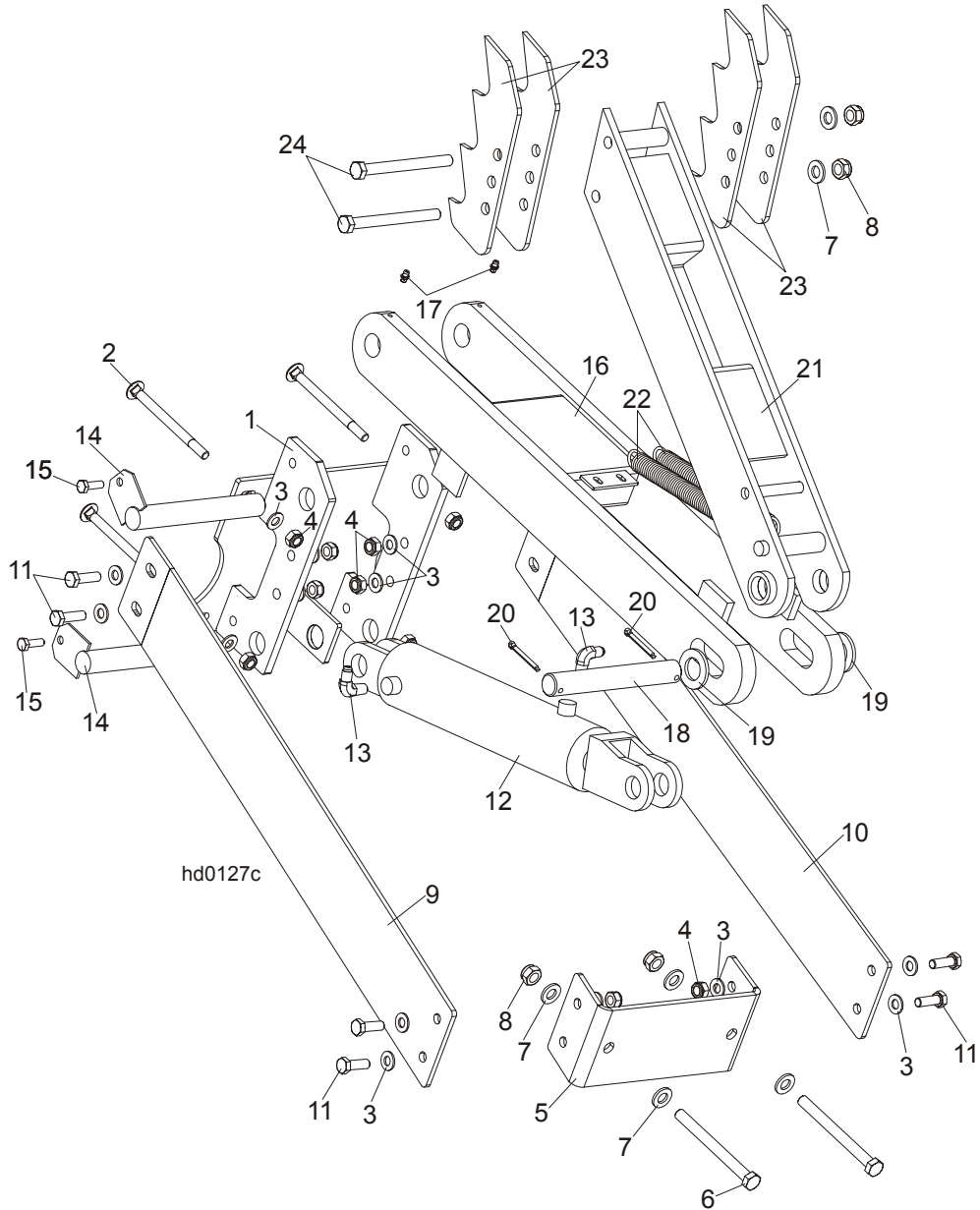

REF	DESCRIPTION (◆ Indicates Parts Available In Assemblies Only)	PART #	QTY.
	OBRACAK HYDRAULICZNY DO RAM KRÓTKICH	088711	1
1	Uchwyt mocujący obracaka hydr.	088710-1	1
2	Śruba zamk. M10x120 8.8 Fe/Zn5 PN-M/82406	F81003-33	4
3	Washer, Flat, M10, Zinc	F81055-1	20
4	Nut, M10, Nylon Hex Zinc Lock	F81033-1	12
5	Uchwyt obracaka przedni	091046-1	1
6	Bolt, M12x130-8.8-Fe/Zn5 PN-M/82101	F81004-36	2
7	Washer, M12, Flat, Zinc	F81056-1	6
8	Nut, M12, Hexagon, Nylon, Zinc, Lock	F81034-2	4

9	Blacha boczna lewa, obracak krótki	091048-1	1	
10	Blacha boczna prawa, obracak krótki	091049-1	1	
11	Bolt, M10x30MM, Hex Head, Gr 5.8 Zinc	F81003-2	8	
	Cylinder Assy, Log Turner Super	015563	1	
12	Cylinder, CJ-S305-16-63/28/203 Hydraulic	088679	1	
13	Fitting, 1/4NPTx1/4JIC Male Elbow	P09142	2	
14	Pin, Log Turner Mount	088667-1	2	
15	Bolt, M8 x 25mm Hex Head Gr 5.8 Zinc	F81002-5	2	
16	Arm, Hydraulic Log Turner Link	088060-1	1	
17	Smarownicza M6 PN-M/86003	086280	2	
18	Pin, 25 X 180	088664	1	
19	Podkładka 25 Fe/Zn5 PN-78/M-82005	F81061-3	2	
20	Zawleczka S-Zn 5x40 PN-M/82001	F81043-31	2	
21	Arm, Hydraulic Log Turner Painted	088067-1	1	
22	Spring, 7/8x8 1/2x1/8 Ext	P09136	2	
23	Claw, Hydraulic Log Turner	088082-1	4	
24	Bolt, M12x130-8.8-Fe/Zn5 PN-M/82101	F81004-36	2	

9.6 Hydraulic Log Side Supports

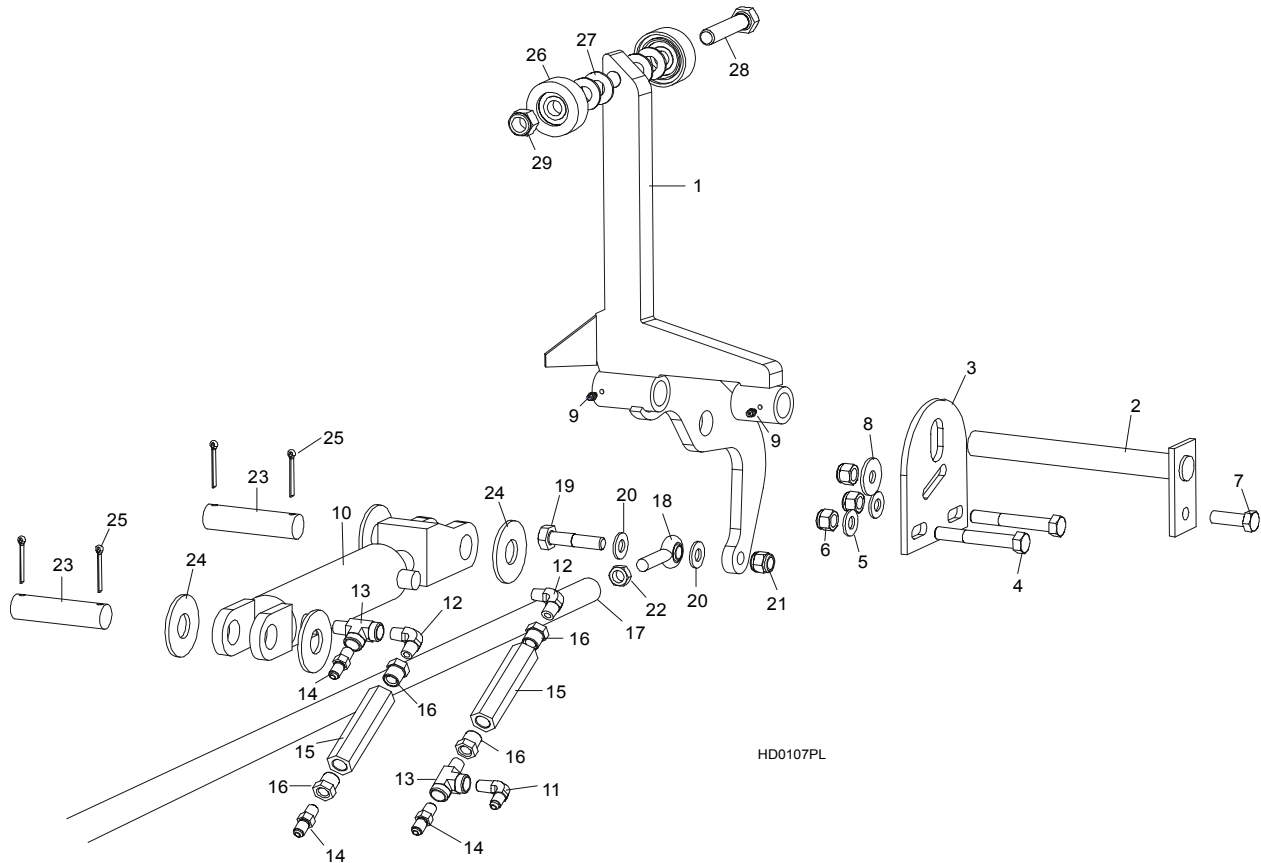

REF	DESCRIPTION (◆ Indicates Parts Available In Assemblies Only)	PART #	QTY.	
	ZESTAW OPOREK BOCZNYCH LT30/40	092611	1	
1	SUPPORT, HYDRAULIC LOG SIDE	091653-1	2	
2	PIN, LOG SIDE SUPPORT PIVOT	091549-1	1	
3	PLATE, LOG SIDE SUPPORT END	091591-1	1	
4	BOLT, M12X 75MM, HH, GRADE 5.8,ZINC	F81004-21	2	
5	WASHER, 13 FLAT	F81056-1	2	
6	NUT, M12-8 HEX NYLON LOCK	F81034-2	3	
7	BOLT, M12X 35MM, HH, GRADE 5.8,ZINC	F81004-24	1	
8	WASHER, 45/13	086184	1	
9	FITTING, 3/16" GREASE	P04107	4	
	CYLINDER ASSEMBLY, SUPER HYDRAULIC LOG SIDE SUPPORT	015561	1	
10	Cylinder hydr. C-J-S270-16-50/28/152	088678	1	◆
	Seal Kit, 6" x 2" Hydraulic Cylinder	P12954	1	
11	Fitting, 3/8" JIC - 1/4" NPT Elbow	015491	2	
12	Fitting, C3529x4 90° Pipe	P09140	2	
13	Fitting, C3759x4 Male 'T'	P09141	2	
14	Fitting, 3/8" JIC - 1/4" NPT	015560	2	

15	Valve, Hydraulic Sequence	015484	2	
16	Fitting, 3/8" NPT - 1/4" NPT Reducer	015490	4	
17	POPYCHACZ OPORY BOCZNEJ CYNK. L-1420	089374-1	1	
18	END, RIGHT ROD	087035	1	
	END, LEFT ROD	087036	1	
19	BOLT, M12 X 45MM, HH, GRADE 5.8, ZINC	F81004-32	2	
20	WASHER, 7.4 SAE FLAT	F81056-1	4	
21	NUT, M12-8 HEX NYLON LOCK	F81034-2	2	
22	NUT, M12-04-A RIGHT HEX JAM	F81034-6	1	
	NUT, M12-04-A LEFT HEX JAM	F81034-7	1	
23	PIN, CYLINDER MOUNT	086979-1	2	
24	WASHER, 28 SAE FLAT	F81061-1	4	
25	PIN, 5 X 40 COTTER	F81043-31	4	
	ROLLER KIT, SIDE SUPPORT	015109	2	
26	Roller Assembly, Side Support	015014-1	2	
27	Washer, 17 Flat	F81058-1	4	
28	Bolt, M16x65MM, HH,F/Thrd, Grade 5.8, Zinc	F81006-1	1	
29	Nut, M16, Hex, Nylon Zinc Lock	F81036-2	1	
	Instruction Sheet, Side Support Roller	015109-526	1	

9.7 Hydraulic Log Clamp

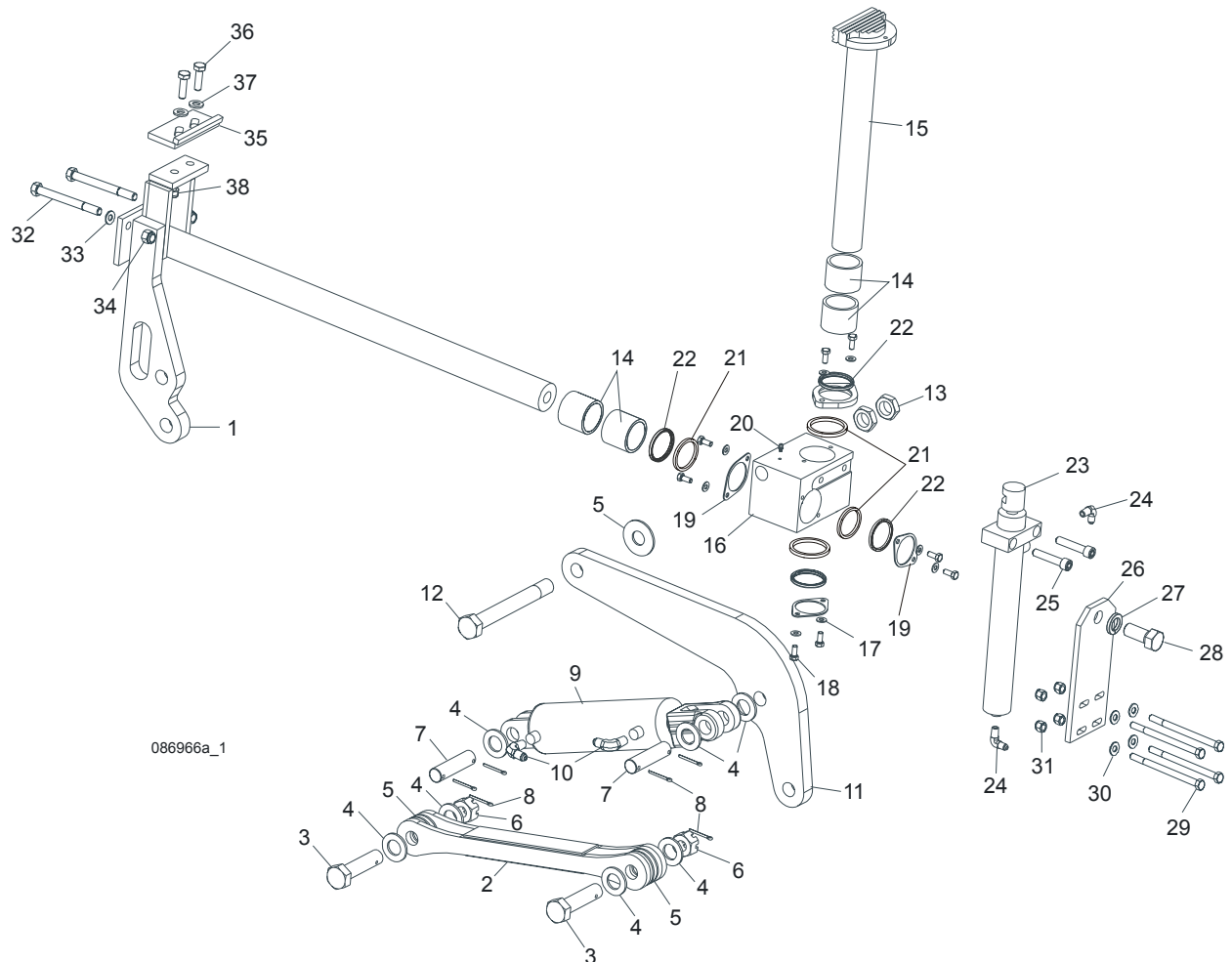

REF	DESCRIPTION (◆ Indicates Parts Available In Assemblies Only)	PART #	QTY.
	CLAMP ASSEMBLY, SUPER HYDRAULIC	088658	1
1	Mount Weldment, Super Clamp Tube	086967-1	1
2	Arm, Clamp Link	086963-1	1
3	Bolt, B 24x95/85 Hex Head Grade 8	F81049-2	1
4	Washer, 25 Flat	F81061-3	8
5	Washer, 25X63 Hardened	088585-1	5
6	Nut, M20-8-B Slotted Hex	F81037-3	2
7	Pin, Cylinder Mount	086979-1	2
8	Pin, 6,3x45 Cotter	F81045-2	6
9	Cylinder, CJ-S96-16-70/32/178 Hydraulic	088589	1
10	Fitting, 1/4" NPT - 3/8" JIC Elbow	P09142	2
11	Link Weldment, Super '99 Clamp	086974-1	1
12	Bolt, M24x217/39 -8.8-B Hex Head Grade 8	088586-1	1
13	Nut, M24 -04-B Hex Jam	F81039-3	2

14	Bushing, Clamp Slide 5040BS	088660	2	
15	Clamp Weldment, Vertical Super	088582-1	1	
16	Block, Vertical Clamp Mount	088591-1	1	
17	Washer, 8.4 Flat	F81054-1	8	
18	Bolt, M8x20-8.8-B Hex Head	F81002-4	8	
19	Flange, Wiper Ptd	088887-1	3	
20	Fitting, 3/16" Grease	P04107	1	
21	Spacer, Log Clamp	089324	1	
22	Wiper, Up/Down Rod ZZ 50x60x7	088587	1	
23	Cylinder, CJ-S169-16-40/22/254 Hydraulic	088590	1	
24	Fitting, 1/4" NPT - 1/4" JIC Elbow	P09142	2	
25	Screw, M12x55 -8.8-B Socket Head	F81004-23	2	
26	Plate, Super Log Clamp Mount	086975-1	1	
27	Washer, Z 22,5 Split Lock	F81059-4	1	
28	Bolt, M22x1,5x40 -8.8-B Hex Head Grade 5	F81009-1	1	
29	Bolt, M10 x 125-8.8 Hex Head	F81003-18	4	
30	Washer, 10.5 Flat	F81055-1	8	
31	Nut, M10-8-B Hex Nylon Lock	F81033-1	4	
32	Bolt, M10 x 130-8.8 Hex Head	F81004-36	2	
33	Washer, 13 Flat	F81056-1	2	
34	Nut, M12-8 Hex Nylon Lock	F81034-1	2	
	CLAMP STOP KIT, HYDRAULIC LOG	K09485	1	
35	Plate, Clamp Stop	086980-1	1	
36	Bolt, M12 x 40-8.8 Hex Head	F81004-4	2	
37	Washer, 13 Flat	F81056-1	2	
38	Nut, M12-8 Hex Nylon Lock	F81034-2	2	

9.8 Hydraulic Toe Board

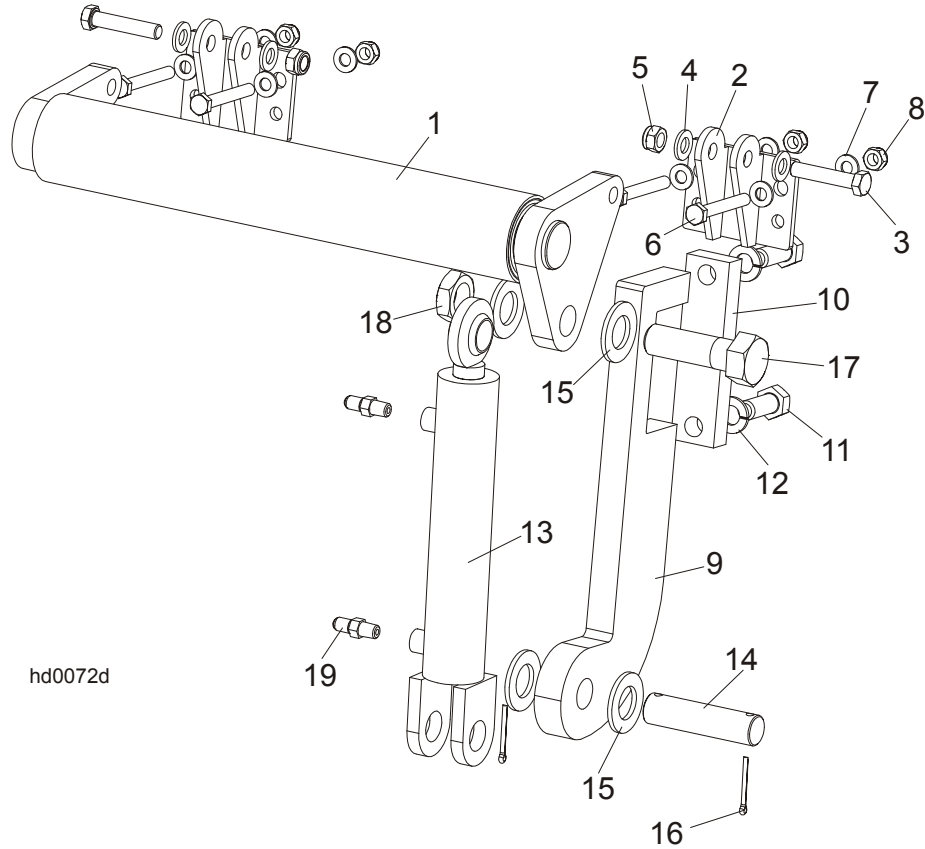

REF	DESCRIPTION (◆ Indicates Parts Available In Assemblies Only)	PART #	QTY.
	HYDRAULIC TOE BOARD - FRONT	092613	1
	HYDRAULIC TOE BOARD - REAR	092634	1
1	Toe Board Weldment, Hydraulic - Front	092612-1	1
	Toe Board Weldment, Hydraulic - Rear	086253-1	1
2	Uchwyt montażu rolki poziomowania kłody	087903-1	4
3	Bolt, M12X60mm, Hex Head Gr 8.8	F81004-5	4
4	Washer, M12 , Flat, Zinc	F81056-1	8
5	Nut, M12, Hexagon, Nylon, Zinc, Lock	F81034-2	4
6	Bolt, M10x75-8.8-Fe/Zn5 PN-M/82101	F81003-15	8
7	Washer, Flat, M10, Zinc	F81055-1	16
8	Nut, M10, Nylon Hex Zinc Lock	F81033-1	8
9	Bracket, Hydraulic Toeboard Mount	087729-1	2
10	Plate, Hydraulic Toeboard Mount	090086-1	2
11	Bolt, M16x40mm ,HH, F/THRD, Grade 5.8, Zinc	F81006-13	4
12	Washer, 17 Split Lock	F81058-2	4
13	Cylinder, CJ-S170-16-40/25/152 Hydraulic	088681	2
14	Pin, Cylinder Mount	086979-1	2
15	Washer 28 Fe/Zn5	F81061-1	8
16	Pin, 3/16x1.5 Cotter	F05012-23	4

17	Bolt, 1-8x3 1/4 HH Gr5	F05009-51	2	
18	Nut, 1-14 Hex Jam Unplated	F05010-117	2	
19	Fitting, 1/4NPTx1/4JIC Male	P09143	4	