

Wood-Mizer[®] Sawmill

Parts Manual

LT40 Series MH

rev. C8.00



Safety is our #1 concern! Read and understand all safety information and instructions before operating, setting up or maintaining this machine.

February 1998

Form #534

Table of Contents

Section-Page

SECTION 1	GENERAL INFORMATION	1-1
1.1	How To Use The Parts List	1-1
1.2	Sample Assembly	1-1
SECTION 2	BLADE GUIDE ROLLERS & ARM	2-1
2.1	Blade Guide Assembly, Idle Side (Standard).....	2-1
2.2	Idle Side Blade Guide Assembly, Optional (LMS).....	2-3
2.3	Blade Guide Assembly, Drive Side.....	2-5
2.4	Blade Guide Arm & Rollers	2-7
2.5	Blade Guide Arm Drive Assembly.....	2-8
SECTION 3	BLADE WHEELS & TENSIONER	3-1
3.1	Blade Drive Assembly.....	3-1
3.2	Idle Blade Wheel Assembly	3-3
3.3	Hydraulic Blade Tensioner Assembly.....	3-4
SECTION 4	SAW HEAD	4-1
4.1	Middle Throat Screw	4-1
4.2	Water Lube Solenoid Valve	4-2
4.3	Clutch Lever Assembly	4-3
4.4	Brake Assembly.....	4-5
4.5	Board Return Assembly	4-7
4.6	Water Lube Assembly	4-9
4.7	Saw Head Decals.....	4-11
4.8	Blade Housing Covers.....	4-13
4.9	Drive Belt Covers	4-15
4.10	Sawdust Chute.....	4-17
SECTION 5	CONTROL & BATTERY BOXES	5-1
5.1	Control Assembly, LT40 Series	5-1
5.2	Drum Switches	5-3
5.3	Circuit Breakers.....	5-4
5.4	Solenoid Assemblies	5-5
5.5	Front Panel Assembly & Harnesses	5-6
5.6	Battery Box Assembly, LT40 Series	5-7
5.7	Fuse Box Assembly, LT40 Series	5-8
SECTION 6	UP/DOWN SYSTEM	6-1
6.1	Saw Head V-Brace Mount	6-1
6.2	Blade Height Scale	6-2
6.3	Up/Down Chain & Sprockets.....	6-4

Table of Contents

Section-Page

6.4	Up/Down Motor Assembly, LT40 Series	6-6
6.5	Up/Down Drive Assembly, LT40 Series	6-7
SECTION 7 POWER FEED & TRACK ROLLERS		7-1
7.1	Upper Track Rollers And Wipers.....	7-1
7.2	Power Feed Assembly,	7-2
7.3	Feed Chain/Stop, LT40 Series	7-4
7.4	Lower Track Rollers	7-6
SECTION 8 BED FRAME ASSEMBLY		8-1
8.1	Bed Rail Assembly, Front And Rear	8-1
8.2	Bed Rail Assembly, Front Middle	8-2
8.3	Bed Rail Assembly, Rear Middle	8-3
8.4	Leg, Stationary	8-4
8.5	Board Return Table Assembly	8-6
8.6	Pivot Bed Rail Assembly.....	8-8
8.7	Log Side Support Assembly	8-10
8.8	Tie Down Chain Assembly	8-12
8.9	Saw Head Rest Pin Assembly	8-13
8.10	Bed Frame Decals	8-14
SECTION 9 LOG CLAMP, TURNER, LOADER & TOE BOARDS		9-1
9.1	Manual Log Clamp	9-1
9.2	Log Clamp Assembly	9-2
9.3	Manual Log Turner.....	9-4
9.4	Manual Toe Board.....	9-6
9.5	Log Loading Ramps	9-8

SECTION 1 GENERAL INFORMATION

1.1 How To Use The Parts List

- Use the index above to locate the assembly that contains the part you need.
- Go to the appropriate section and locate the part in the illustration.
- Use the number pointing to the part to locate the correct part number and description in the table.
- Parts shown indented under another part are included with that part.
- Parts marked with a diamond (◆) are only available in the assembly listed above the part.

See the sample table below. Sample Part #A01111 includes part F02222-2 and subassembly A03333. Subassembly A03333 includes part S04444-4 and subassembly K05555. The diamond (◆) indicates that S04444-4 is not available except in subassembly A03333. Subassembly K05555 includes parts M06666 and F07777-77. The diamond (◆) indicates M06666 is not available except in subassembly K05555.

1.2 Sample Assembly				
REF	DESCRIPTION (◆ Indicates Parts Available In Assemblies Only)	PART #	QTY.	
	Sample Assembly, Complete (Includes All Indented Parts Below)	A01111	1	
1	Sample Part	F02222-22	1	
	Sample Subassembly (Includes All Indented Parts Below)	A03333	1	
2	Sample Part (◆ Indicates Part Is Only Available With A03333)	S04444-4	1	◆
	Sample Subassembly (Includes All Indented Parts Below)	K05555	1	
3	Sample Part (◆ Indicates Part Is Only Available With K05555)	M06666	2	◆
4	Sample Part	F07777-77	1	

To Order Parts:

- From Europe call our European Headquarters and Manufacturing Facility in Kolo, Poland at **+48-63-2626000**. From the continental U.S., call our toll-free Parts hotline at **1-800-448-7881**. Have your customer number, vehicle identification number, and part numbers ready when you call.
- From other international locations, contact the Wood-Mizer distributor in your area for parts.

SECTION 2 BLADE GUIDE ROLLERS & ARM

2.1 Blade Guide Assembly, Idle Side (Standard)

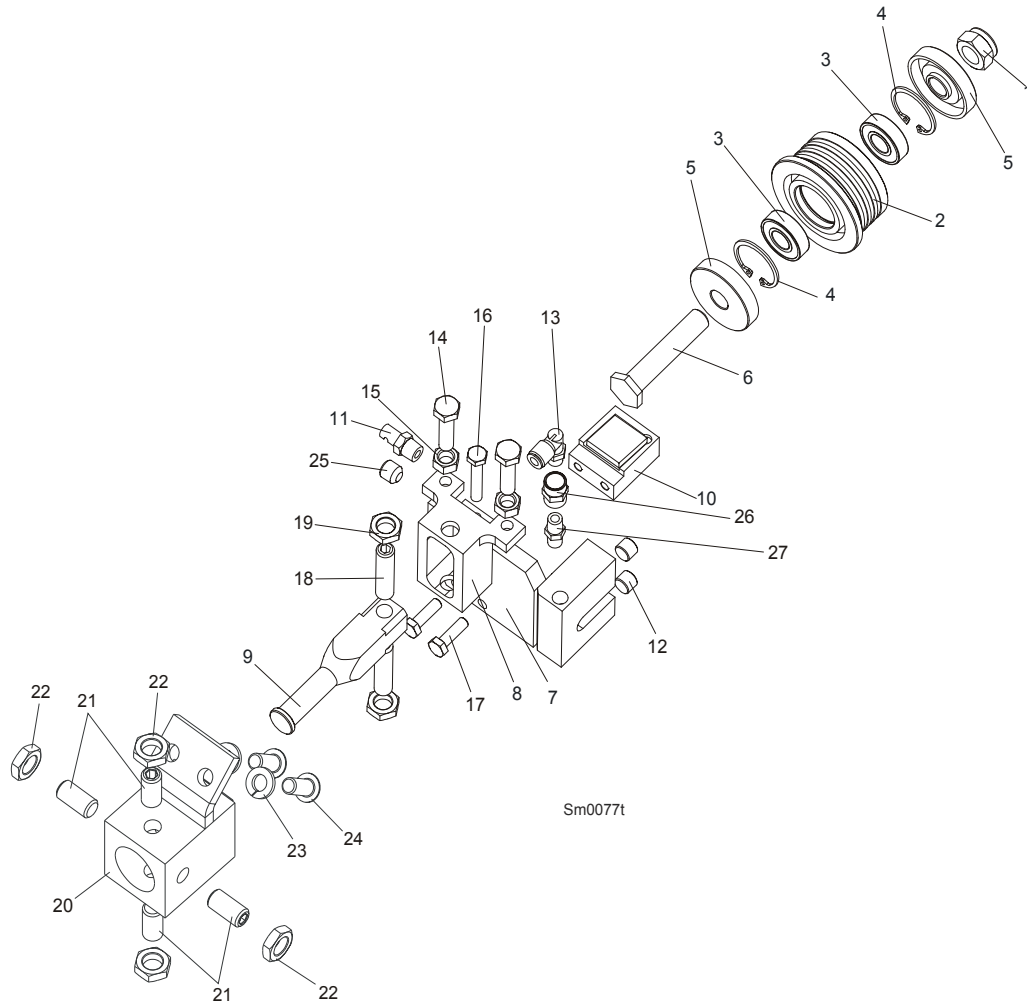

REF	DESCRIPTION (◆ Indicates Parts Available In Assemblies Only)	PART#	QTY.
	BLADE GUIDE ASSEMBLY, IDLE SIDE	092523	1
	BLADE GUIDE ASSEMBLY, IDLE SIDE, EXTENDED (for optional use with 1 1/2" blades)	092994	1
	Roller, Blade Guide Narrow W/Bearings	088261	1
	Roller, Blade Guide W/Bearings Extended (for optional use with 1 1/2" blades)	092939	1
1	Nut, M12-8 Hex Nylon Zinc Lock	F81034-2	1
2	Roller, Blade Guide Narrow	087889	1
	Roller, Blade Guide Extended (for optional use with 1 1/2" blades)	087890	1
3	Bearing, 6001 2RSR NACHI	087893	2
4	Ring, W28 Inside Retaining	F81090-9	2
5	Washer, Spacer	087891-1	2 (1)
	Washer, Spacer (used with the Extended Roller only) ¹	087892-1	1
6	Bolt, Blade Guide Roller Zinc Plated	087761-1	1

2

Blade Guide Rollers & Arm

Blade Guide Assembly, Idle Side (Standard)

	Bolt, Blade Guide Roller Zinc Plated (used with the Extended Roller only)	092940-1	1	
7	Block Weldment, Nozzle Zinc Plated	087750-1	1	
8	Block, Zinc Plated Roller Guide Adjuster	087756-1	1	
9	Shaft, Zinc Plated Blade Guide Mount	088255-1	1	
10	Disc Assembly, EZ-Glide Blade Guide Wear	087760	1	
11	Nozzle, Blade Water Lube Spray	016637	1	
12	Plug, M10x1 DIN 906 BN40 "BOSSARD"	F81015-3	2	
13	Fitting, 90° Elbow 1/8NPT-1/4 Tube Swivel	P09736	1	
14	Bolt, M8x30 DIN933 A2-70 Stainless Steel	F81002-27	2	
15	Nut, M8 DIN934 A2-70 Stainless Steel	F81032-7	2	
16	Bolt, M6x30 DIN933 A2-70 Stainless Steel	F81001-37	1	
17	Bolt, M6x20-8.8 Hex Head Full Thread Zinc	F81001-2	2	
18	Screw, M10x1x40 DIN913 Stainless Steel Set	F81015-2	2	
19	Nut, M10x1 DIN439 Stainless Steel Thin	F81033-7	2	
20	BLOCK WELDMENT, PAINTED BLADE GUIDE MOUNT	088292-1	1	
21	SCREW, M10X1X20 DIN913 STAINLESS STEEL SET	F81015-1	4	
22	NUT, M10X1 DIN439 STAINLESS STEEL THIN	F81033-7	4	
23	WASHER, 8.2 SPLIT LOCK ZINC	F81054-4	2	
24	BOLT, 5/16-18X3/4 SOCKET HEAD	F05006-102	2	
25	FITTING, 1/8 NPT SOCKET PIPE PLUG	P30127	1	
26	FITTING, 1/8FPT COUPLING	P05748	1	
27	NIPPLE, 1/8 DRY SEAL	P02764	1	

¹ Used only from the flanged side of the roller

2.2 Idle Side Blade Guide Assembly, Optional (LMS)

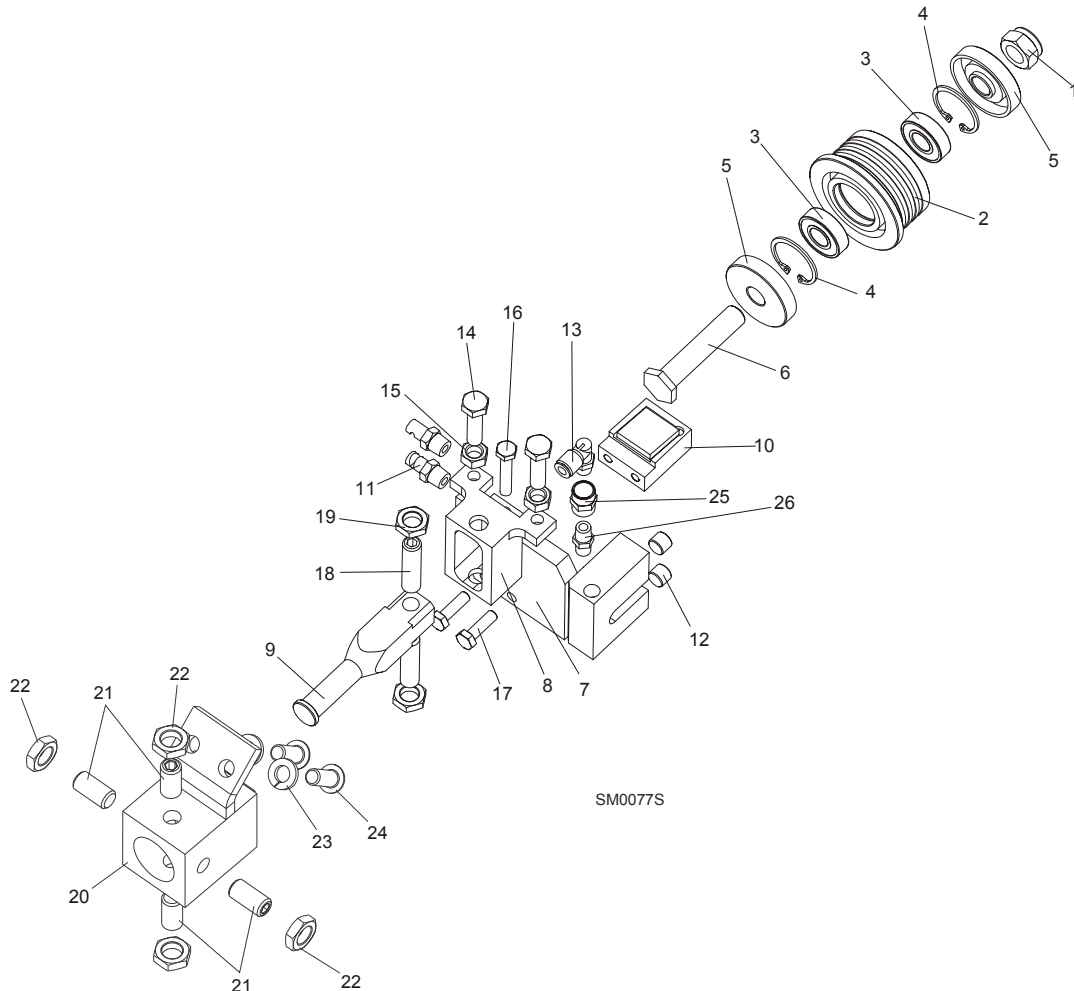

REF	DESCRIPTION (◆ Indicates Parts Available In Assemblies Only)	PART#	QTY.
	BLADE GUIDE ASSEMBLY, IDLE SIDE	087749	1
	BLADE GUIDE ASSEMBLY, IDLE SIDE. EXTENDED (for optional use with 1 1/2" blades)	092996	1
	Roller, Blade Guide Narrow W/Bearings	088261	1
	Roller, Blade Guide W/Bearings Extended (for optional use with 1 1/2" blades)	092939	1
1	Nut, M12-8 Hex Nylon Zinc Lock	F81034-2	1
2	Roller, Blade Guide Narrow	087889	1
	Roller, Blade Guide Extended (for optional use with 1 1/2" blades)	087890	1
3	Bearing, 6001 2RSR NACHI	087893	2
4	Ring, W28 Inside Retaining	F81090-9	2
5	Washer, Spacer	087891	2 (1)
	Washer, Spacer (used with the Extended Roller only) ¹	087892-1	1
6	Bolt, Blade Guide Roller Zinc-Plated	087761-1	1
	Bolt, Blade Guide Roller Zinc Plated (used with the Extended Roller only)	092940-1	1

2

Blade Guide Rollers & Arm

Idle Side Blade Guide Assembly, Optional (LMS)

7	Block Weldment, Nozzle Zinc-Plated	087750-1	1	
8	Block, Zinc-Plated Roller Guide Adjuster	087756-1	1	
9	Shaft, Zinc-Plated Blade Guide Mount	088255-1	1	
10	Disc Assembly, EZ-Glide Blade Guide Wear	087760	1	
11	Nozzle, Blade Lube Spray	033479	2	
12	Plug, M10x1 DIN 906 BN40 "BOSSARD"	F81015-3	2	
13	Fitting, 90° Elbow 1/8NPT-1/4 Tube Swivel	P09736	1	
14	Bolt, M8x30 DIN933 A2-70 Stainless Steel	F81002-27	2	
15	Nut, M8 DIN934 A2-70 Stainless Steel	F81032-7	2	
16	Bolt, M6x30 DIN933 A2-70 Stainless Steel	F81001-37	1	
17	Bolt, M6x20-8.8 Hex Head Full Thread Zinc	F81001-2	2	
18	Screw, M10x1x40 DIN913 Stainless Steel Set	F81015-2	2	
19	Nut, M10x1 DIN439 Stainless Steel Thin	F81033-7	2	
20	BLOCK WELDMENT, PAINTED BLADE GUIDE MOUNT	088292-1	1	
21	SCREW, M10X1X20 DIN913 STAINLESS STEEL SET	F81015-1	4	
22	NUT, M10X1 DIN439 STAINLESS STEEL THIN	F81033-7	4	
23	WASHER, 8.2 SPLIT LOCK ZINC	F81054-4	2	
24	BOLT, 5/16-18X3/4 SOCKET HEAD	F05006-102	2	
25	FITTING, 1/8FPT COUPLING	P05748	1	
26	NIPPLE, 1/8 DRY SEAL	P02764	1	

¹ Used only from the flanged side of the roller

2.3 Blade Guide Assembly, Drive Side

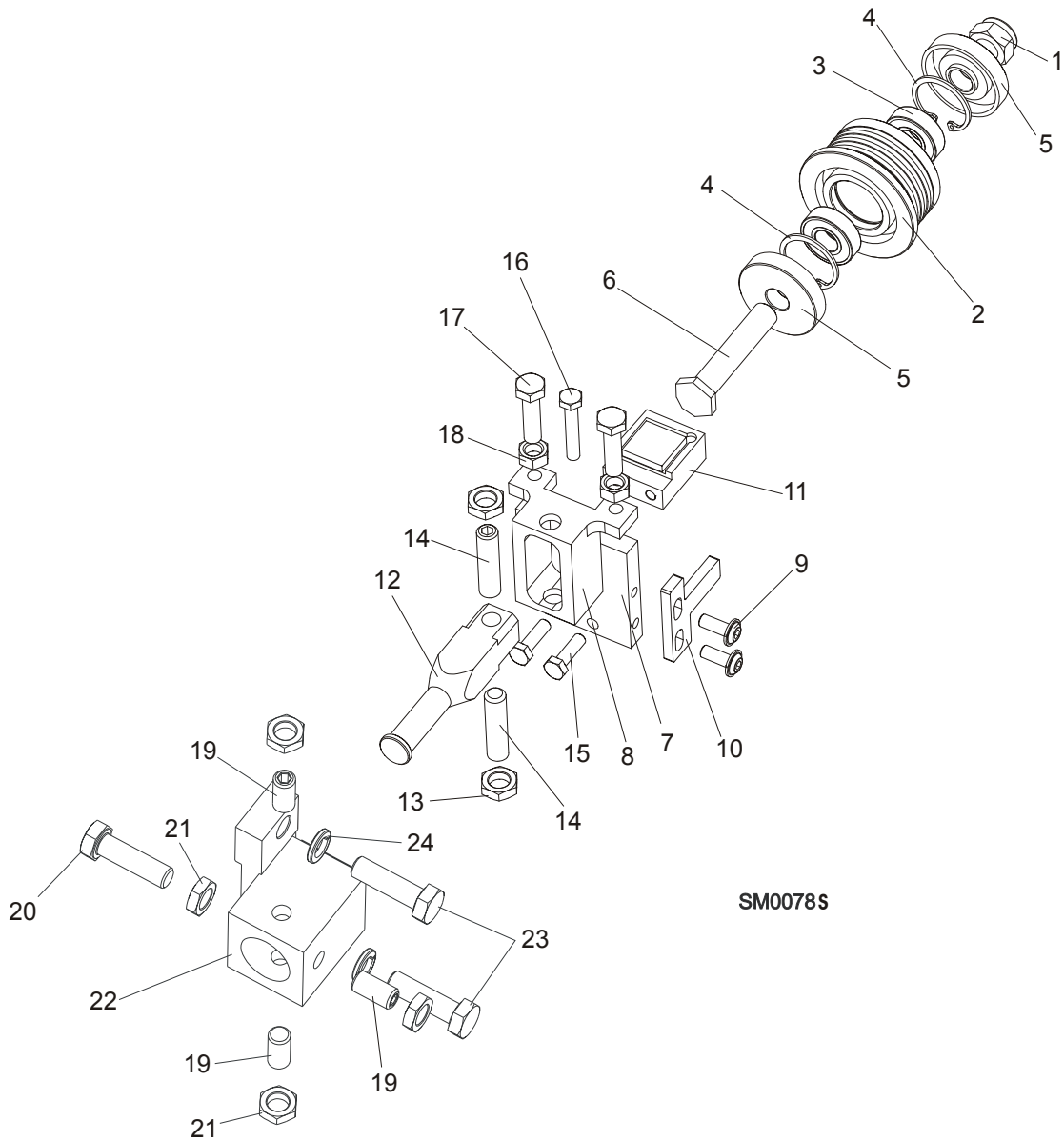

REF	DESCRIPTION (◆ Indicates Parts Available In Assemblies Only)	PART#	QTY.
	BLADE GUIDE ASSEMBLY, DRIVE SIDE	087748	1
	BLADE GUIDE ASSEMBLY, DRIVE SIDE, Extended (for optional use with 1 1/2" blades)	092995	1
	Roller, Blade Guide Narrow W/Bearings	088261	1
	Roller, Blade Guide W/Bearings Extended (for optional use with 1 1/2" blades)	092939	1
1	Nut, M12-8 Hex Nylon Zinc Lock	F81034-2	1
2	Roller, Blade Guide Narrow	087889	1
	Roller, Blade Guide Extended (for optional use with 1 1/2" blades)	087890	1
3	Bearing, 6001 2RSR NACHI	087893	2

2

Blade Guide Rollers & Arm

Blade Guide Assembly, Drive Side

4	Ring, W28 Inside Retaining	F81090-9	1	
5	Washer, Spacer	087891	2 (1)	
	Washer, Spacer (used with the Extended Roller only) ¹	087892-1	1	
6	Bolt, Blade Guide Roller Zinc-Plated	087761-1	1	
	Bolt, Blade Guide Roller Zinc Plated (used with the Extended Roller only)	092940-1	1	
7	Plate, Zinc-Plated Blade Guide Mounting	087753-1	1	
8	Block, Zinc-Plated Roller Guide Adjuster	087756-1	1	
9	Screw, M6x16 BN 11252 "BOSSARD"	F81001-24	2	
10	Wiper, Blade Zinc-Plated	087757-1	1	
11	Disc Assembly, EZ-Glide Blade Guide Wear	087760	1	
12	Shaft, Zinc-Plated Blade Guide Mount	088255-1	1	
13	Nut, M10x1 DIN439 Stainless Steel Thin	F81033-7	2	
14	Screw, M10x1x40 DIN913 Stainless Steel Set	F81015-2	2	
15	Bolt, M6x20-8.8 Hex Head Full Thread Zinc	F81001-2	2	
16	Bolt, M6x30 DIN933 A2-70 Stainless Steel	F81001-37	1	
17	Bolt, M8x30 DIN933 A2-70 Stainless Steel	F81002-27	2	
18	Nut, M8 DIN934 A2-70 Stainless Steel	F81032-7	2	
19	Screw, M10X1X20 DIN913 Stainless Steel Set	F81015-1	3	
20	BOLT, M10X1X25 DIN 933 STAINLESS STEEL	F81003-28	1	
21	NUT, M10X1 DIN439 STAINLESS STEEL THIN	F81033-7	4	
22	BLOCK WELDMENT, BLADE GUIDE MOUNT	087744	1	
23	BOLT, M10X35-8.8 HEX HEAD FULL THREAD ZINC	F81003-17	2	
24	WASHER, 10.2 SPLIT LOCK ZINC	F81055-2	2	

¹ Used only from the flanged side of the roller

2.4 Blade Guide Arm & Rollers

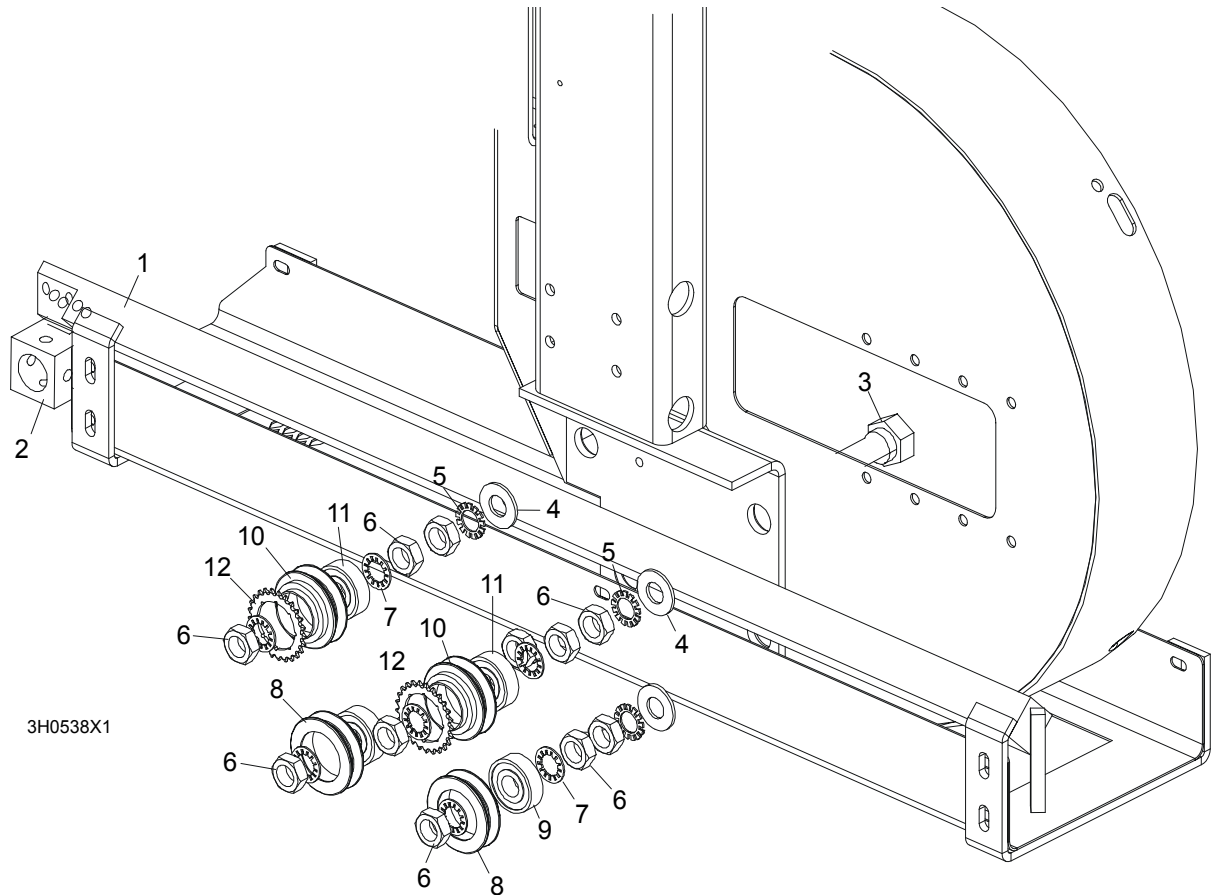

REF	DESCRIPTION (◆ Indicates Parts Available In Assemblies Only)	PART #	QTY.	
1	BLADE GUIDE ARM WELDMENT	087018-1	1	
2	Tube, Blade Guide Mount (G.S. - Bolted to Blade Guide Arm)	W10426	1	
3	BOLT, BLADE GUIDE ARM ROLLER CAM	086508-1	4	
4	WASHER, 17 FLAT	F81058-1	4	
5	WASHER, 5/8" EXTERNAL STAR	F05011-26	4	
6	NUT, 5/8-18 HEX JAM	F05010-11	12	
7	WASHER, 5/8" INTERNAL STAR	F05011-25	8	
	ROLLER ASSEMBLY, BLADE GUIDE ARM WITH BEARING	A09059	2	
8	Roller, Blade Guide Arm V-Groove	S07989-W	1	◆
9	Bearing, 6203-2NSL 5/8" I.D.	P06030-1	1	
	ROLLER ASSEMBLY, BLADE GUIDE ARM WITH BEARING AND SPROCKET	A09932	2	
10	Roller, Blade Guide Arm Drive	S09930-W	1	◆
11	Bearing, 6203-2NSL 5/8" I.D.	P06030-1	1	
12	Sprocket, #25 26-Tooth	015939	1	◆

2.5 Blade Guide Arm Drive Assembly

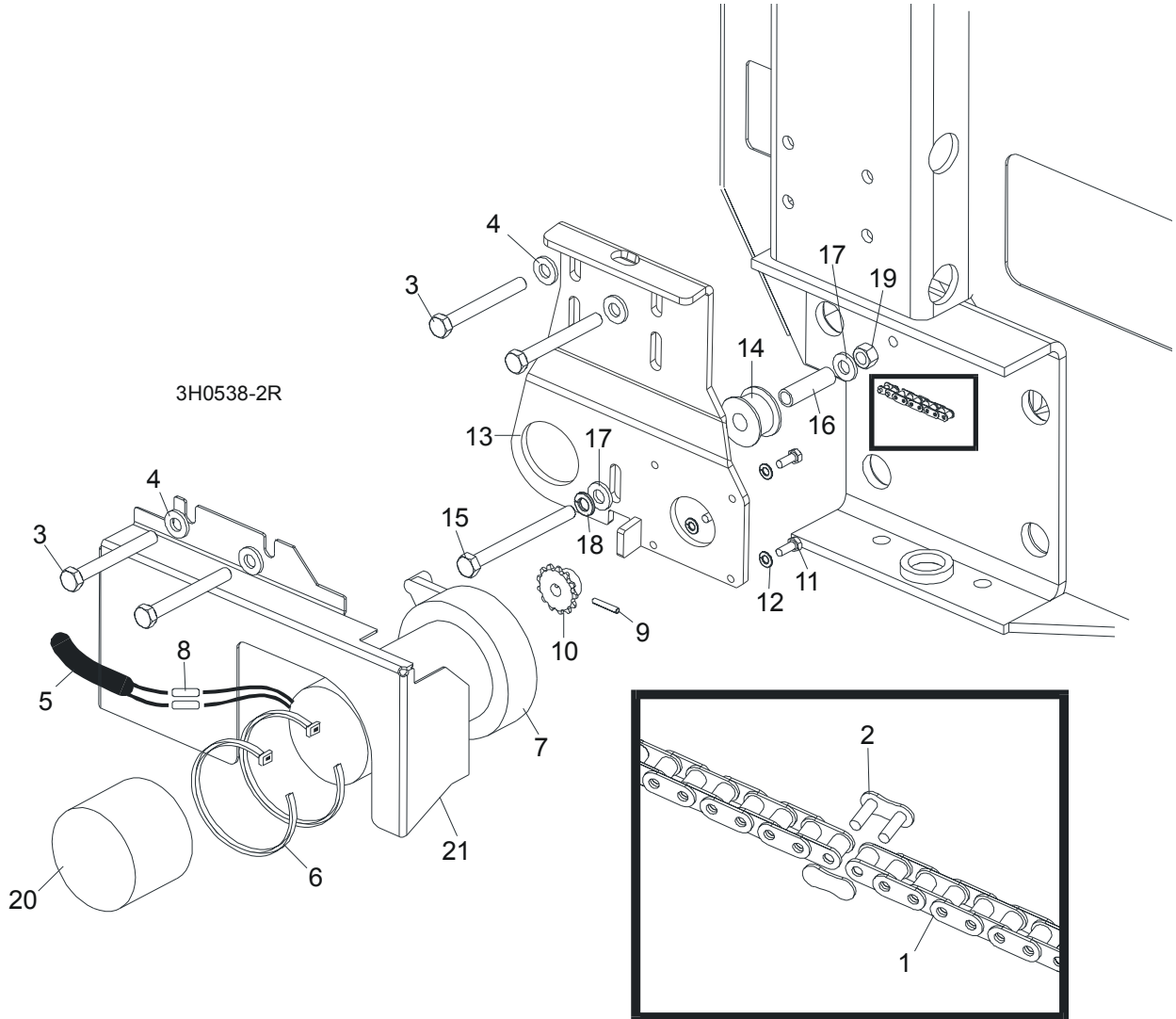

REF	DESCRIPTION (◆ Indicates Parts Available In Assemblies Only)	PART #	QTY.
1	CHAIN, #25 X 20 1/4"	P09984	1
2	LINK, #25 MASTER	P09983	1
3	BOLT, 5/16-18 X 2 3/4" HEX HEAD GRADE 5	F05006-28	4
4	WASHER, 8.4 FLAT	F81054-1	4
5	TUBE, 3/8" X 1/2" NEOPRENE	R01897	0,75 m
6	WRAP, 1/4" X 6" TIE	F05089-1	2
	DRIVE ASSEMBLY, BLADE GUIDE ARM	091005	1
	Motor Assembly, Blade Guide Arm Replacement	A10365	1
7	Motor, Blade Guide Arm 53:1 Gear	P09698-1	1
	Housing, Klauber Motor End	P12756	1
	Gear Kit, Klauber Motor Replacement	P12569	1

	Brush Kit, Gear Motor Replacement	P12800	1	
	Shaft Kit, Klauber Gear Motor Replacement	009695	1	
8	Connector, 14 Gauge Butt	F04875-1	2	
9	Pin, 1/8" X 3/4" Roll	F05012-6	1	
10	Sprocket, Gear Motor #25 14-Tooth	P09970	1	
11	Screw, #10-32 x 1/2" Hex Head	F05004-60	4	
12	Washer, 5.1 Split Lock	F81052-2	4	
	Instruction Sheet, Blade Guide Arm Motor	A10353-296	1	
13	Bracket, Blade Guide Arm Motor Mount	087994-1	1	
14	Roller, Blade Guide Arm Chain Idler	S09999	1	
15	Bolt, M8x90-8.8 Hex Head Full Thread	F81002-16	1	
16	Spacer, 5/16" I.D. X 1 1/2"	S09996	1	
17	Washer, 5/16" SAE Flat	F81054-1	3	
18	Washer, 8.2 Split Lock	F05011-13	1	
19	Nut, M8-8-B Hex Lock	F81032-1	1	
20	Boot, Gear Motor Weather	023720	1	
21	COVER, BLADE GUIDE ARM MOTOR	093460-1	1	

SECTION 3 BLADE WHEELS & TENSIONER

3.1 Blade Drive Assembly

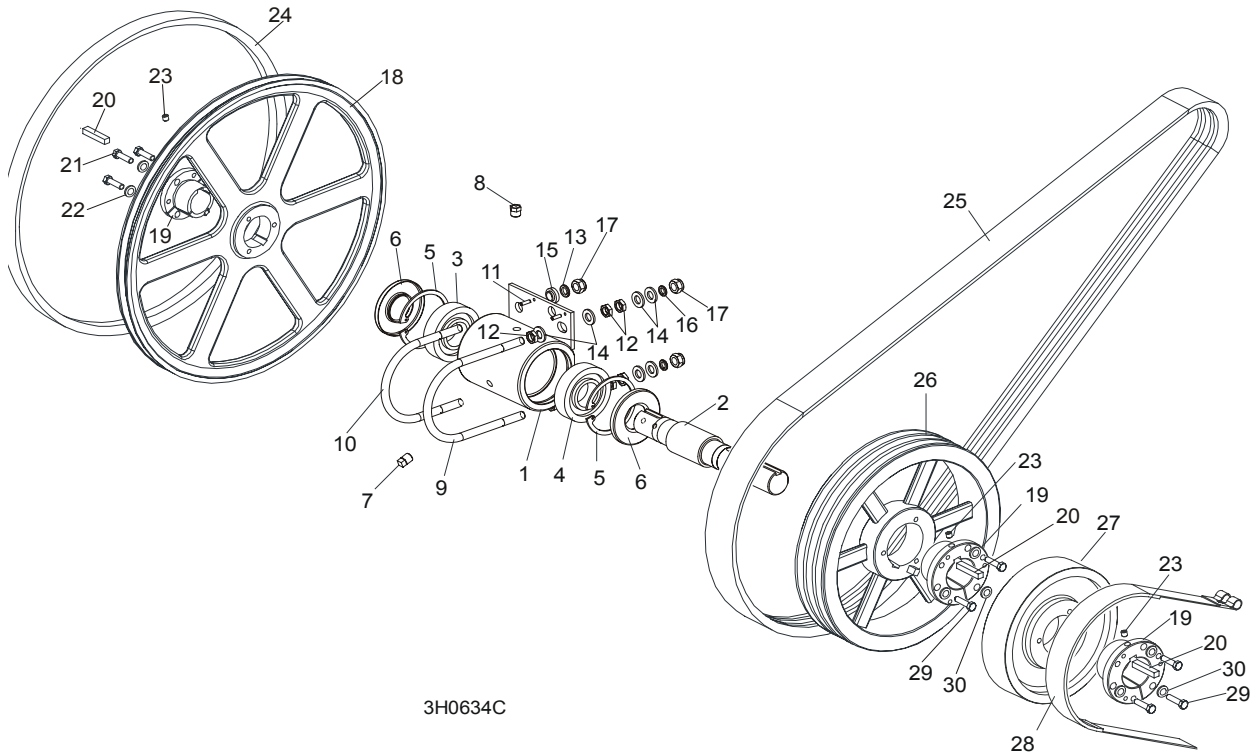

REF	DESCRIPTION (◆ Indicates Parts Available In Assemblies Only)	PART #	QTY.
	BEARING ASSEMBLY, DRIVE	086291	1
1	Housing, Blade Wheel Drive Bearing	086293	1
2	Shaft, Blade Wheel Drive	086292	1
3	Bearing, Blade Wheel Drive NJ308	085939	1
4	Bearing, Blade Wheel Drive #6308	085940	1
5	Ring, 90mm Interior Retaining #17	F04254-17	2
6	Seal, Drive Bearing #CR15890	P10206	2
7	Plug, 1/4" NPT Square Head	P05498	1
8	Plug, 1/4" NPT Vented	P12868	1
9	Bolt, 1/2-13 Long U	S10207-1P	1
10	Bolt, 1/2-13 Short U	S10207-2P	1
11	Pin, 3/16" X 5/8" Roll	F05012-22	2
12	Nut, M12-04-A Hex Jam	F81034-6	6
13	Washer, 12.2 Split Lock	F81056-2	2
14	Washer, 13 SAE Flat	F81056-1	8
15	Spacer, Zinc	086769-1	2
16	Washer, 10.2 Split Lock Zinc	F81055-2	2

17	Nut, M12-8 Hex Nylon Lock	F81034-2	4	
	WHEEL KIT, DRIVE SIDE BLADE	014562	1	
18	Wheel, Drive Side Blade	016284	1	
19	Bushing, Modified 1 9/16" P1	087214	1	
20	KEY, 9.5h7x9.5x3.8	087384	3	
21	BOLT, UNC 1/4"x1 1/2"-8.8 ZINC DIN933 HEX HEAD	F05005-31	3	
22	WASHER, 1/4" UNC ZINC SPLIT LOCK	F81052-21	3	
23	SCREW, M8x8-33H ZINC HEX SOCKET SET FLAT POINT	F81014-1	3	
24	BELT, BLADE WHEEL B57	P04185	1	
25	BELT, 3BX72 DRIVE (D42)	014085	1	
	BELT, 3BX73 DRIVE (D38)	091548	1	
	BELT, 3BX74 DRIVE (E25HP 50HZ)	014249	1	
26	PULLEY, 3B5V124 SPECIAL DRIVE	087203-1	1	
27	WHEEL, BRAKE	087204-1	1	
28	STRAP, METAL-BACKED BRAKE	014391	1	
29	BOLT, M8X35-8.8 ZINC HEX HEAD FULL THREAD	F81002-13	6	
30	WASHER, 8.2 ZINC SPLIT LOCK	F81054-4	6	

3.2 Idle Blade Wheel Assembly

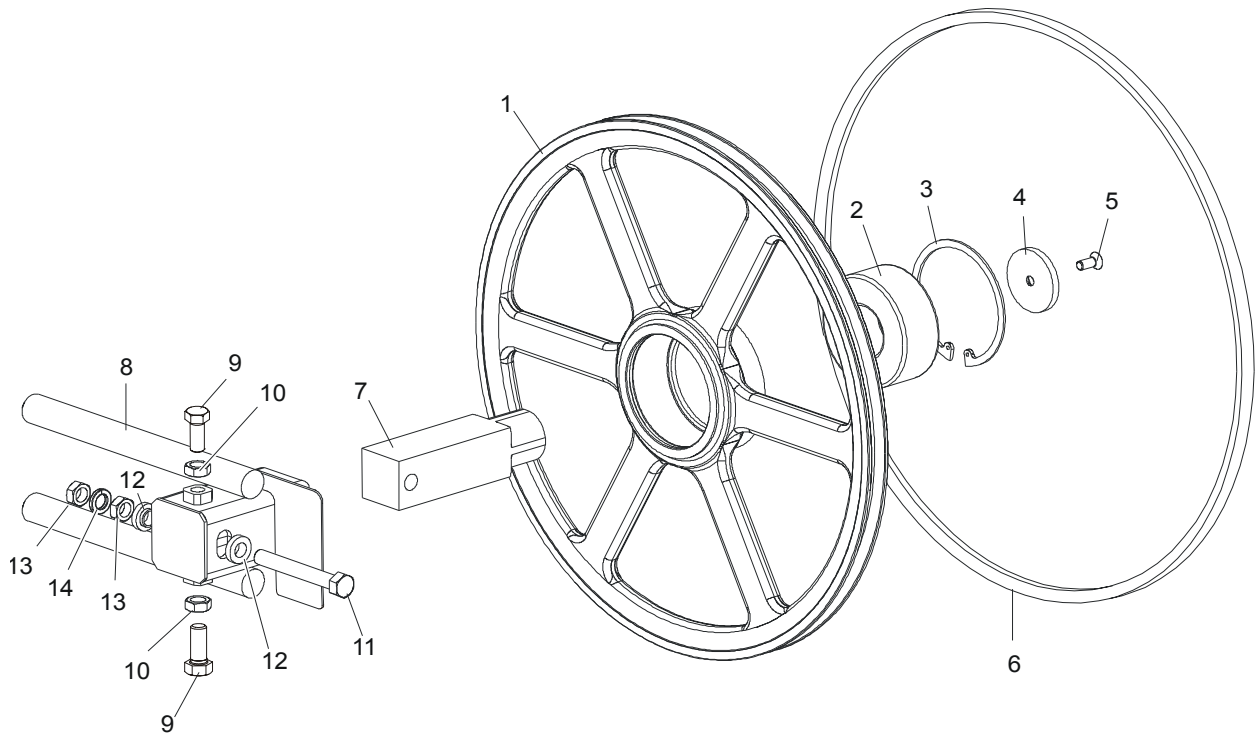

SM0241C

REF	DESCRIPTION (◆ Indicates Parts Available In Assemblies Only)	PART #	QTY.	
	WHEEL ASSEMBLY, IDLE SIDE BLADE	016120	1	
1	Wheel, Idle Side Blade	016013	1	◆
2	Bearing, Idle Side Blade Wheel #5309-2RS, C3, SRI-2 Grease	086428	1	
3	Ring, 100mm Internal Retaining Beveled	F04254-28	1	
4	RETAINER, 2 3/16 X 1/4"	016397	1	
5	SCREW, 3/8-16X1	F05007-64	1	
6	BELT, BLADE WHEEL B57	P04185	1	
7	SHAFT, IDLE BLADE WHEEL	016398	1	
8	HOUSING, IDLE BLADE WHEEL SHAFT	087665	1	
9	SCREW, 1/2-20 X 1 1/4" FLAT POINT SET	F05008-108	2	
10	NUT, 1/2-20 HEX JAM	F05010-16	2	
11	BOLT, 1/2-20 X 3 3/4" HEX HEAD FULL THREAD GRADE 2	F05008-111	1	
12	SPACER, 1/2" I.D. FLANGED	086769-1	2	
13	NUT, 1/2-20 HEX JAM	F05010-16	2	
14	WASHER, 12.2 SPLIT LOCK	F81056-2	1	

3.3 Hydraulic Blade Tensioner Assembly

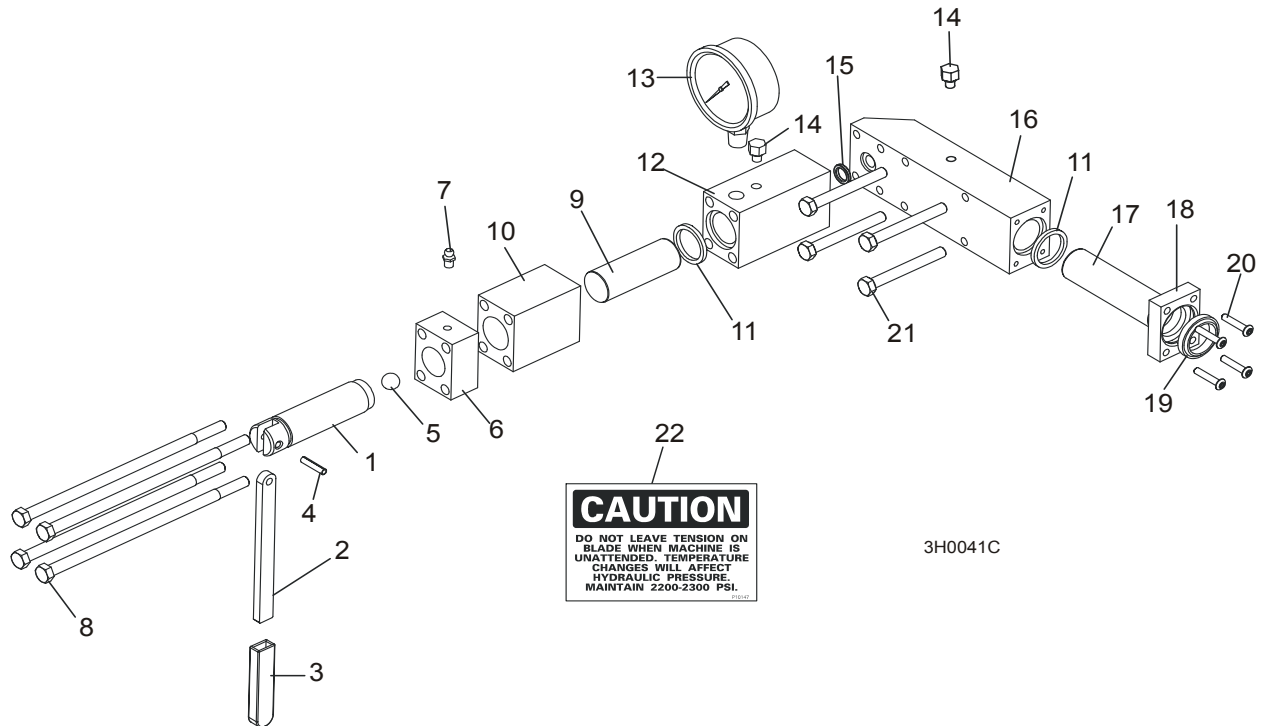

CAUTION
DO NOT LEAVE TENSION ON
BLADE WHEN MACHINE IS
UNATTENDED. TEMPERATURE
CHANGES WILL AFFECT
HYDRAULIC PRESSURE.
MAINTAIN 2200-2300 PSI.

3H0041C

REF	DESCRIPTION (◆ Indicates Parts Available In Assemblies Only)	PART #	QTY.
	HYDRAULIC BLADE TENSIONER ASSEMBLY	A10054	1
	Handle Assembly, Hydraulic Blade Tensioner Screw	A12294	1
1	Screw, Hydraulic Blade Tensioner	S10056	1
2	Handle, Hydraulic Tensioner Screw	S08174	1
3	Sleeve, Plastic Handle	P08072	1
4	Pin, 3/16" x 7/8" Roll	F05012-11	1
5	Ball, 1/2" Steel	P02720	1
6	Block, Threaded Tensioner End	S10062	1
7	Fitting, 1/4-28 Grease	P05060	1
	Instruction Sheet, Tensioner Screw	A12294-518	1
8	Bolt, 5/16-18 X 7 1/2" Hex Head Grade 5	F05006-43	4
9	Piston, Hydraulic Tensioner Front 2 3/4" Long	S10060	1
10	Block, Piston Guide	S10061	1
11	Seal, 1" Diameter	P10051	2
12	Block, Hydraulic Tensioner Gauge Mounting	S10140	1
13	Gauge, 3000 PSI	090552	1
14	Plug, Hydraulic Tensioner Fill	P10065	2
15	Ring, 5/8" X 3/32" Square "O"	P10377	1
16	Block, Rear Tensioner Piston	S10142	1
17	Piston, Hydraulic Tensioner Rear 3 5/8" Long	S10059	1
18	Block, Rear Piston End	S10089	1
19	Wiper, 1" Diameter	P10053	1
20	Bolt, #10-24 X 1" Socket Button Head	F05004-43	4

3**Blade Wheels & Tensioner***Hydraulic Blade Tensioner Assembly*

21	Bolt, 5/16-18 X 2 3/4" Hex Head Grade 5	F05006-28	4	
22	Decal, Hydraulic Tension Caution	P10147	1	
	Instruction Sheet, Hydraulic Tensioner Installation	A10136-272	1	

SECTION 4 SAW HEAD

4.1 Middle Throat Screw

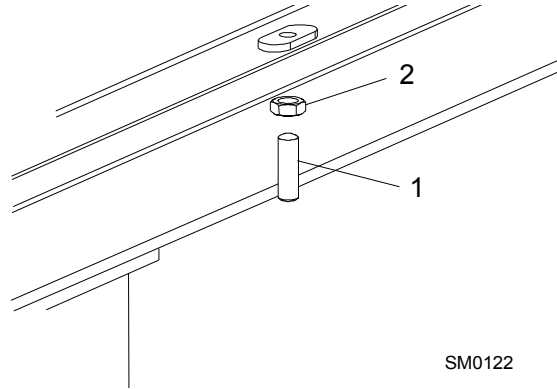

REF	DESCRIPTION (◆ Indicates Parts Available In Assemblies Only)	PART #	QTY.	
1	SCREW, M10X40-45H OVAL POINT SOCKET SET, ZINC	F81003-61	1	
2	NUT, M10-8-B HEX JAM, ZINC	F81033-3	1	

4 Saw Head
Water Lube Solenoid Valve

4.2 Water Lube Solenoid Valve

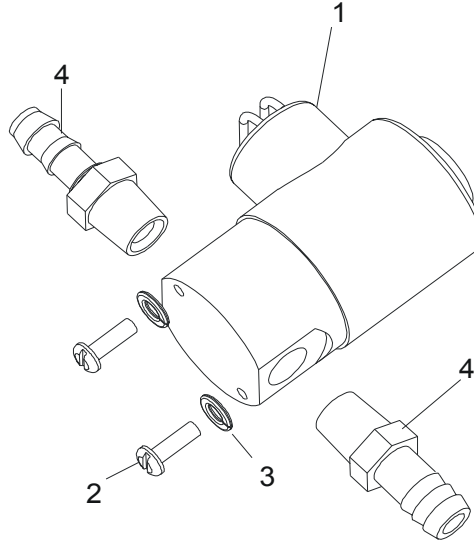

3H0310B

REF	DESCRIPTION (◆ Indicates Parts Available In Assemblies Only)	PART #	QTY.	
1	VALVE, WATER LUBE SOLENOID	016140	1	
2	SCREW, #10-32X1/2" CROSS SLOT ROUND HEAD	F05004-60	2	
3	WASHER, 5.1 SPLIT LOCK	F81052-2	2	
4	FITTING, 1/4" MALE NPT 3/8" HOSE BARB	P04682	2	

4.3 Clutch Lever Assembly

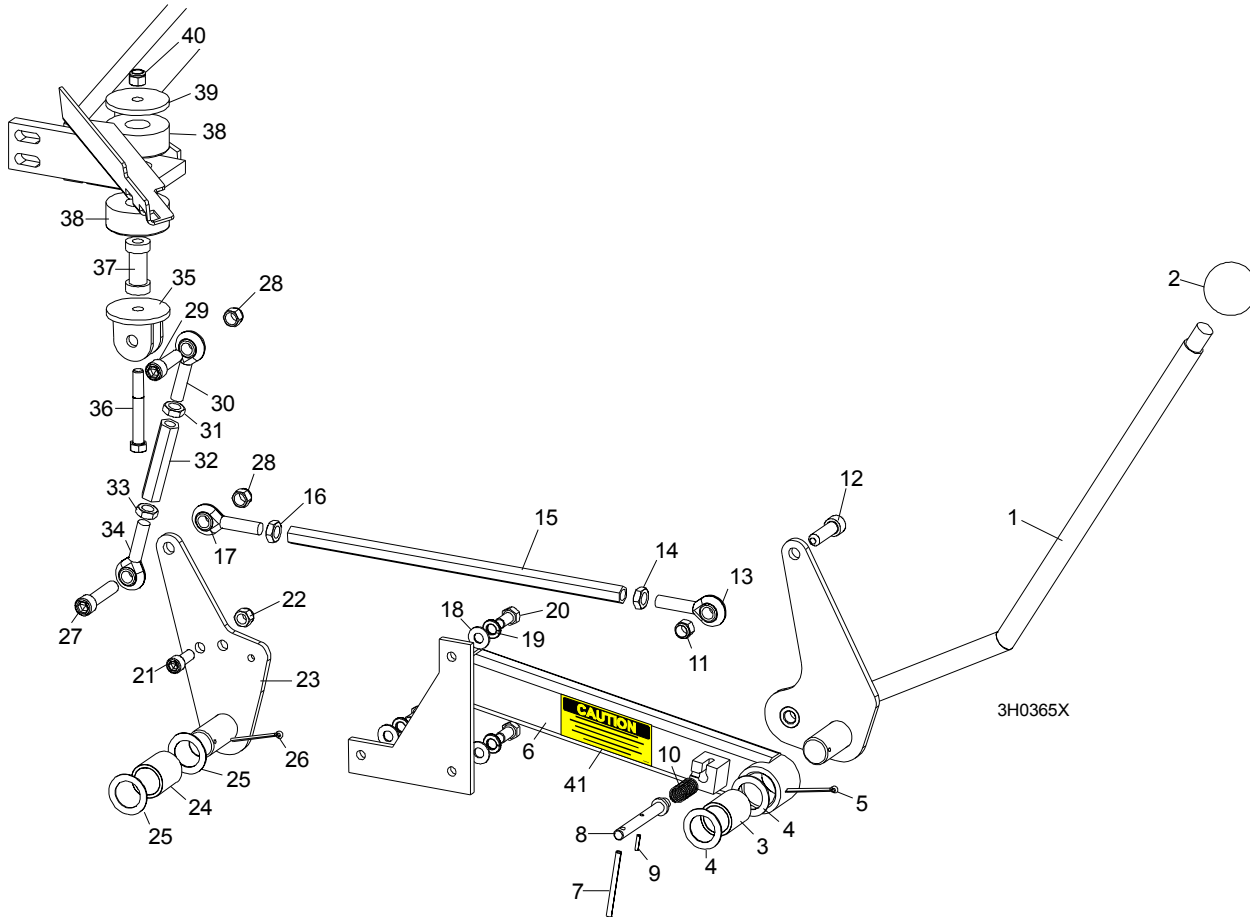

REF	DESCRIPTION (◆ Indicates Parts Available In Assemblies Only)	PART #	QTY.	
	HANDLE ASSEMBLY, EXTENDED CLUTCH/BRAKE	086242	1	
1	Lever, Clutch/Brake	086339-1	1	◆
2	Knob, Plastic Round	086337	1	
3	Bushing, Clutch/Brake Pivot	P05041	1	
4	Washer, Clutch/Brake Pivot	087051-1	2	
5	Pin, 1/8" X 1 3/4" Cotter	F05012-43	1	
6	Extension Weldment, Clutch Handle	086244-1	1	
7	Pin, 3/16 x 2 1/2" Roll	F05012-27	1	
8	Pin, Clutch Detent	086243 ¹	1	◆
9	Pin, 1/8" x 9/16" Roll	F05012-30	1	
10	Spring, .58" OD x 1 1/8"	021243	1	
11	Nut, 7/16-20 Nylon Lock	F05010-83	1	
12	Screw, 7/16-20 x 1 1/2" Socket Head	F05007-55	1	
13	Rod End, 7/16-20 Left Hand Thread	P11578	1	
14	Nut, 7/16-20 Hex Jam Left Hand Thread	F05010-87	1	
15	Rod, Clutch Extension	015073	1	
16	Nut, 7/16-20 Hex Jam	F05010-38	1	

4

Saw Head

Clutch Lever Assembly

17	Rod End, 7/16-20 Right Hand Thread	P11579	1	
18	WASHER, 8.4 SAE FLAT	F81054-1	3	
19	WASHER, 8.2 SPLIT LOCK	F81054-4	3	
20	BOLT, M8X20-8.8-B HEX HEAD	F81002-4	3	
21	BOLT, M10 X 25 SOCKET HEAD	F81003-32	1	
22	NUT, M10-8-B HEX NYLON LOCK	F81033-1	1	
23	PLATE WELDMENT, CLUTCH PIVOT	087086-1	1	
24	BUSHING, CLUTCH/BRAKE PIVOT	P05041	1	
25	WASHER, CLUTCH/BRAKE PIVOT	087051-1	2	
26	PIN, 1/8" X 1 3/4" COTTER	F05012-43	1	
27	SCREW, 7/16-20 X 2" SOCKET HEAD	F05007-120	1	
28	NUT, 7/16-20 HEX NYLON LOCK	F05010-83	2	
29	SCREW, 7/16-20 X 2" SOCKET HEAD	F05007-120	1	
	TURNBUCKLE ASSEMBLY, CLUTCH/BRAKE LEVER	A12304	1	
	TURNBUCKLE ASSEMBLY, 3 3/4" CLUTCH/BRAKE LEVER (50Hz Electric Only)	A11576	1	
30	Rod End, 7/16-20 Right Hand Thread	P11579	1	
31	Nut, 7/16-20 Hex Jam	F05010-38	1	
32	Turnbuckle, 3" Clutch/Brake Lever	S11577	1	
	Turnbuckle, 3 3/4" Clutch/Brake Lever (50Hz Electric Only)	S12262	1	
33	Nut, 7/16-20 Hex Jam Left Hand Thread	F05010-87	1	
34	Rod End, 7/16-20 Left Hand Thread	P11578	1	
35	BRACKET, CLUTCH MOUNT	W12411-1	1	
36	BOLT, M10X70-8.8 HEX HEAD, ZINC	F81003-20	1	
37	SPACER, MOTOR MOUNT VIBRATION BUSHING	S12410	1	
38	BUSHING, MOTOR MOUNT VIBRATION	P05032	2	
39	WASHER, 3/8" I.D. X 2 1/4" O.D. X 3/16" THICK	S12412-0	1	
40	NUT, 3/8-16 NYLON LOCK	F05010-10	1	
41	DECAL, PLACE PIN IN DETENT POSITION	085089	1	

¹ Detent pin removed . Detent pin should be removed from previous revision mills to prevent possible injury caused by unintended use of the detent pin (such as using the pin to enable the blade to be spun by hand during blade tracking). See bulletin #970053LR for pin removal instructions.

4.4 Brake Assembly

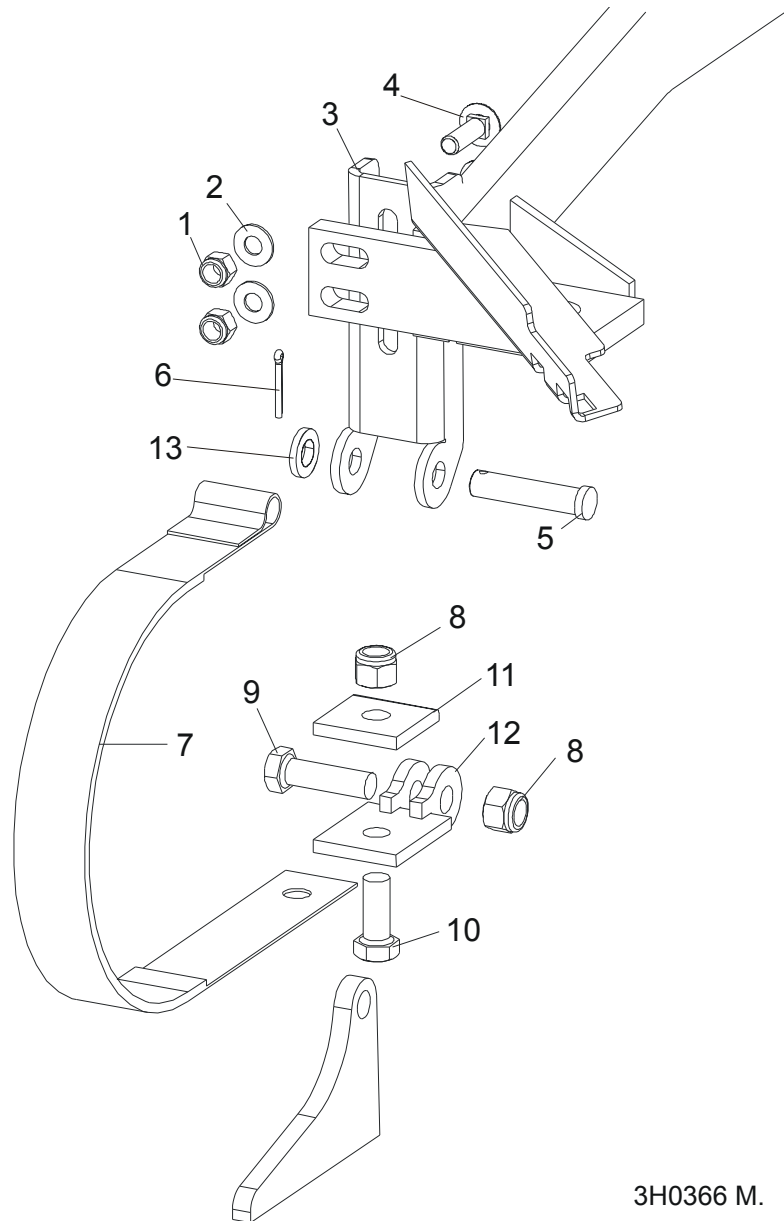

3H0366 M.

REF	DESCRIPTION (◆ Indicates Parts Available In Assemblies Only)	PART #	QTY.
	STRAP RETROFIT, SUPER BRAKE	014441	1
1	Nut, 3/8-16 Nylon Lock	F05010-10	2
2	Washer, 10.5 Flat	F81055-1	2
3	Bracket, Upper Super Brake Strap Mount	014395	1
4	Bolt, 3/8-16 x 1 1/4" Carriage Head Grade 5	F05007-127	2
5	Pin, 1/2" x 2 1/4" Clevis	F05012-81	1
6	Pin, 1/8" x 1" Cotter	F05012-1	1
7	Strap, Upper Pivot Metal Brake	014391	1
8	Nut, M12-8-B Nylon Lock	F81034-2	2

4**Saw Head***Brake Assembly*

9	Bolt, M12 x 40-8.8 Hex Head	F81004-4	1	
10	Bolt, M12 x 30-8.8 Hex Head	F81004-22	1	
11	Plate, Brake Strap Clamp	S04195-1	1	
12	Bracket, Lower Super Brake Strap Mount	014392	1	
13	Washer, 13 Flat Zinc	F81056-1	1	

4.5 Board Return Assembly

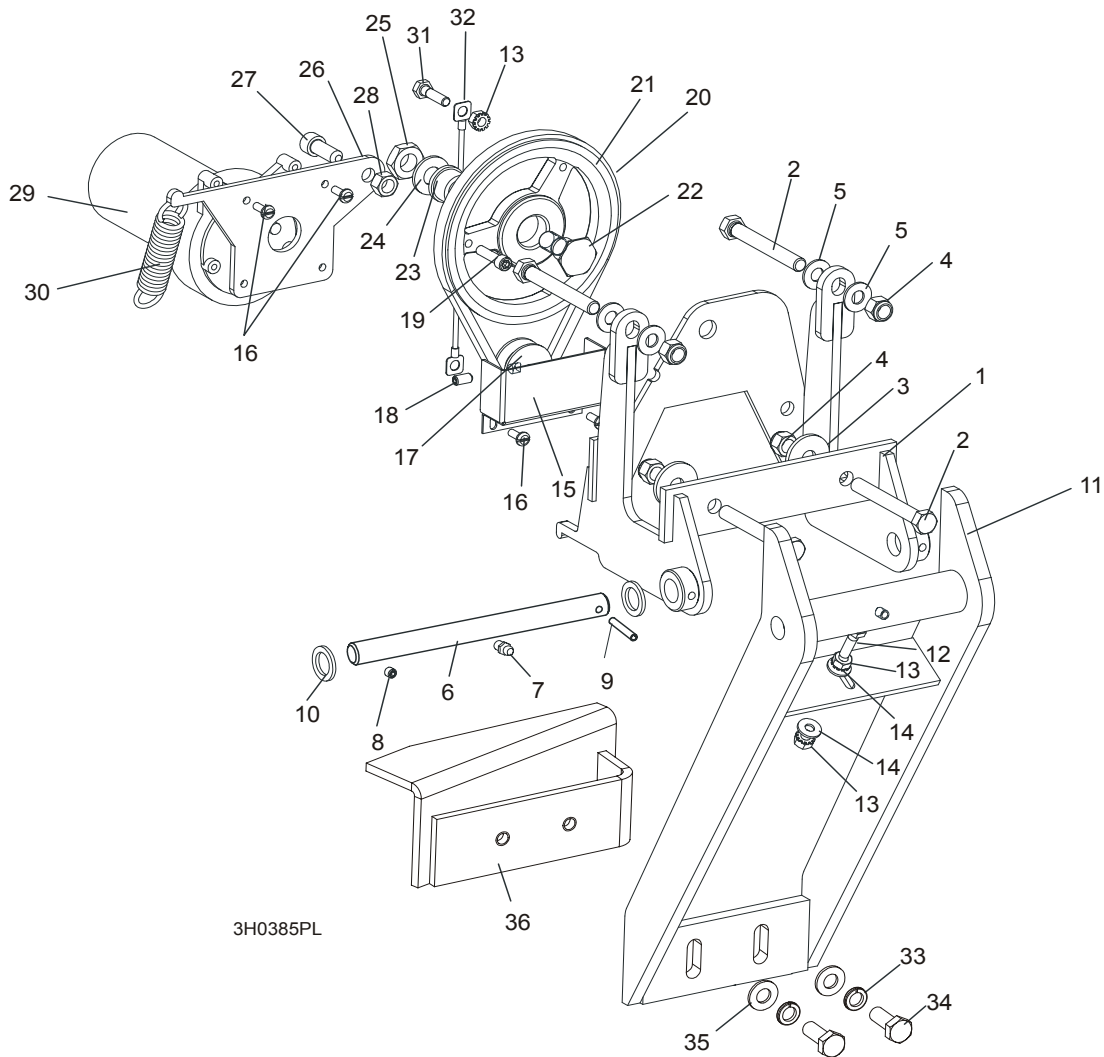

REF	DESCRIPTION (◆ Indicates Parts Available In Assemblies Only)	PART #	QTY.
	RETURN ASSEMBLY, BOARD	087839-1	1
1	Mount Weldment, Board Return	087788-1	1
2	Bolt, 3/8-16 x 3" Full Thread Hex Head	F05007-1	4
3	Washer, 1/8" x 1 1/4"	F81055-1	2
4	Nut, 3/8-16 Hex Nylon Lock	F05010-10	4
5	Washer, 10.5 Flat	F81055-1	4
6	Pin Kit, Board Return Replacement Pivot	087837	1
7	Fitting, M6 Grease	086280	1
8	Screw, M6 X 8 Black Oxide Socket Head Set Cup Point	F81013-1	1
9	Pin, 5 X 30 Roll	F81044-21	1
10	Washer, 5/8" x 15/16" x .094 Nylon	F05011-19	2
11	Arm Weldment, Board Return	087838-1	1

4

Saw Head

Board Return Assembly

12	Screw, 1/4-20 x 1" Full Thread Hex Head Cap	F05005-101	1	
13	Nut, 1/4-20 Self Locking	F05010-9	3	
14	Washer, 6.5 Flat	F81053-11	2	
15	Guard, Board Return Belt	087985-1	1	
16	Screw, 10-32 x 1/2" Hex Head Machine	F05004-60	4	
17	Sheave, 1.42 x .32	015074	1	
18	Screw, 1/4-20 Socket Head Set Cup Point Nylon	F05005-105	1	
19	Screw, 1/4-28 x 1/4" Socket Head Cap	F05005-1	1	
20	Belt, 3L190	015477	1	
21	Sheave, OK50 x 1/2" Modified	015224	1	
22	Bolt, Idler Pulley Pivot	015221	1	
23	Bushing, 5/8" x 7/8" x 1/2" Bronze	P05135	1	
24	Washer, 13 Flat	F81056-1	1	
25	Nut, 1/2-20 Jam Nylon Lock	F05010-79	1	
26	Plate, Motor Pivot	087871-1	1	
27	Screw, M10 x 25-8.8 Black Oxide Socket Head Cap	F81003-32	1	
28	Nut, 3/8-16 Self Locking	F05010-25	1	
29	Motor, 53:1 ASA Gear	P09698-1	1	
30	Spring, 3/4" x 2 7/8" x 12 Gauge	015479	1	
31	Bolt, 1/4-20 x 1" Hex Head Grade 5	F05005-101	1	
32	Cable, Board Return	016090	1	
33	Washer, 10.2 Split	F81055-2	2	
34	Bolt, M10-1.5x25mm HH Gr8.8	F81003-11	2	
35	Washer, 10.5 Flat	F81055-1	2	
36	Angle, Board Return	087835-1	1	

4.6 Water Lube Assembly

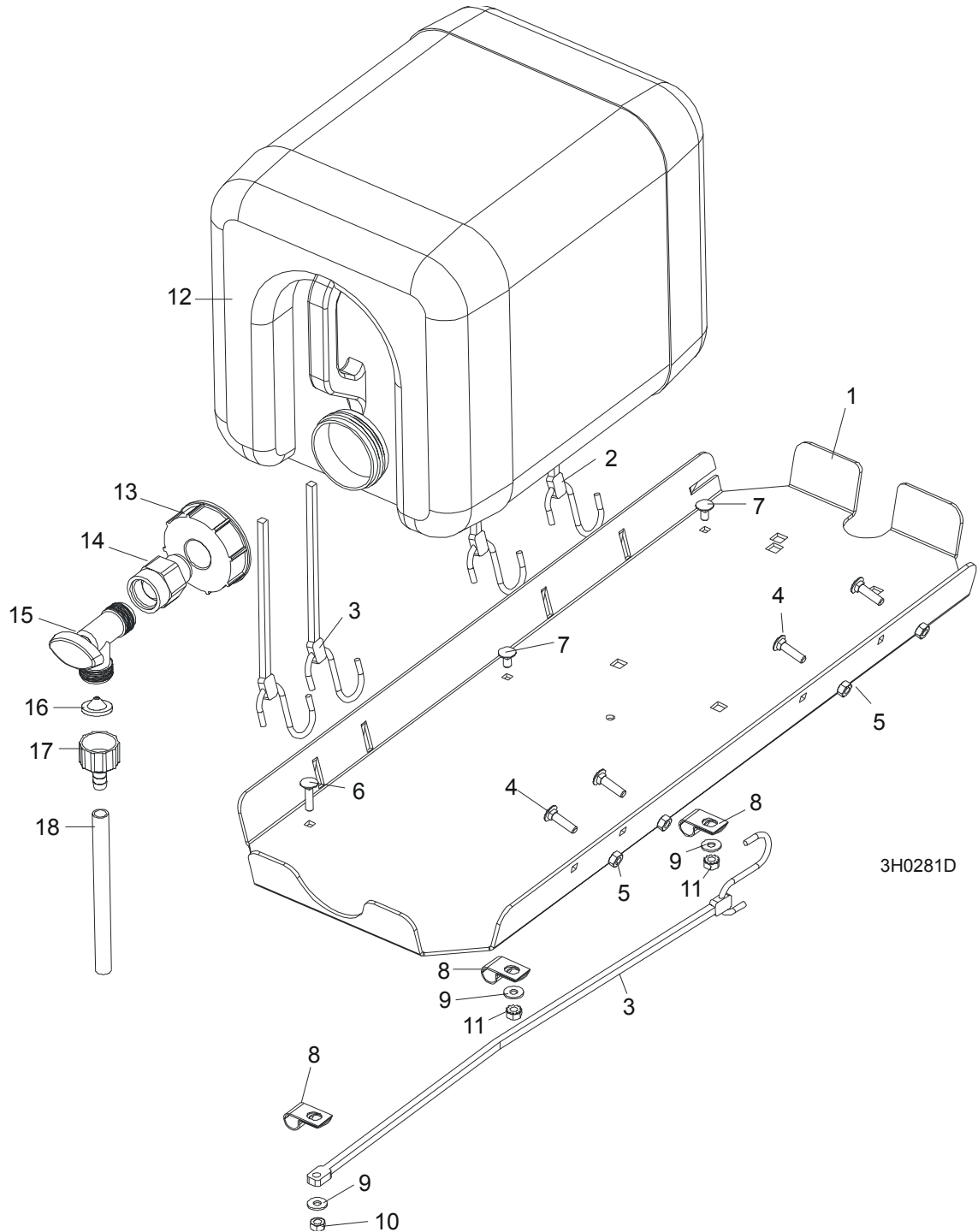

REF	DESCRIPTION (◆ Indicates Parts Available In Assemblies Only)	PART #	QTY.	
	TRAY ASSEMBLY, FUEL TANK/WATER BOTTLE	A11685	1	
1	Tray, Fuel Tank/Water Bottle	090376-1	1	◆

4

Saw Head*Water Lube Assembly*

2	Strap, 24" Rubber (For Fuel Tank - See Engine Manual)	P11258	2	
3	Strap, 20" Rubber	P11668	3	
4	Bolt, 1/4-20 X 1" Carriage Head	F05005-34	4	
5	Nut, 1/4-20 Hex Lock	F05010-21	4	
6	BOLT, 1/4-20 X 1" CARRIAGE HEAD	F05005-34	1	
7	BOLT, 1/4-20 X 1/2" CARRIAGE HEAD	F05005-33	2	
8	CLAMP, 1/2" EMT HOSE	P07584	3	
9	WASHER, 6.5 FLAT ZINC	F81053-11	3	
10	NUT, 1/4-20 HEX LOCK	F05010-21	1	
11	STRAP, 15" RUBBER	P07461	1	
12	NUT, 1/4-20 SELF-LOCKING	F05010-21	2	
	BOTTLE ASSY, WATER LUBE	014642	1	
13	Bottle, 5-Gallon Water Lube	014637	1	
14	Cap, Water Lube Bottle Buttress Thread	014773	1	
15	FITTING, 3/4FPT X 3/4MPT	014636	1	
16	FITTING, WATER LUBE SHUTOFF VALVE	014100	1	
17	FILTER, WATER LUBE	016086 ¹	1	
18	FITTING, 5/8" NPT TO 3/8" HOSE BARB	014113	1	
19	TUBING, WATER LUBE 3/8" I.D.	R01885	2,1 m	

¹ Filter recommended for Super models to prevent debris from entering water lube solenoid valve.

4.7 Saw Head Decals

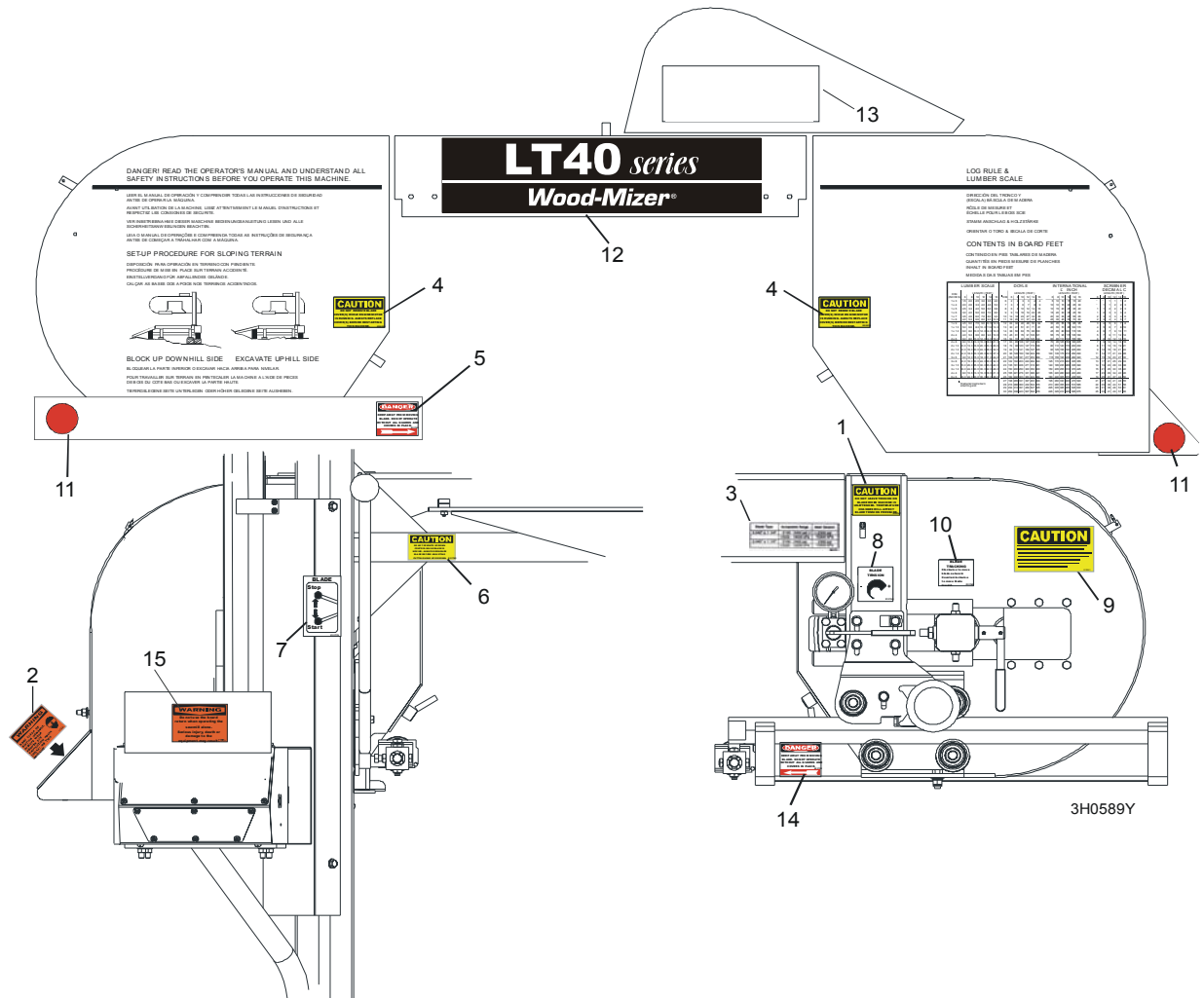

REF	DESCRIPTION (◆ Indicates Parts Available In Assemblies Only)	PART #	QTY.
1	DECAL, BLADE TENSION CAUTION	P10147	1
2	DECAL, SAWDUST CHUTE WARNING	P11754	1
3	DECAL, BLADE TENSION RANGES	085080	1
4	DECAL, BLADE COVERS CAUTION	S20039	2
5	DECAL, BLADE DANGER ARROW RIGHT	S11752	1
6	DECAL, UP/DOWN CAUTION	S11762	1
7	DECAL, BLADE START/STOP	P11779	1
8	DECAL, BLADE TENSION INFO	P11790	1
9	DECAL, SECURE THE SAW HEAD (PORTABLE SAWMILL ONLY)	S12581	1
10	DECAL, BLADE ALIGNMENT INFO	P11789	1
11	DECAL, RED REFLECTIVE 2" ROUND (PORTABLE SAWMILL ONLY)	P07452	2
12	DECAL, SAWMILL TYPE	092763	
13	DECAL, WOOD-MIZER WHAT'S IN A NAME	S12528	1
14	DECAL, BLADE DANGER ARROW LEFT	S11751	1
15	DECAL, EYE/EAR PROTECTION WARNING	S11753	1

4**Saw Head***Saw Head Decals*

	DECAL, EYE/EAR PROTECTION WARNING	S11753	1	
	DECAL, EYE/EAR PROTECTION WARNING	S11753	1	

4.8 Blade Housing Covers

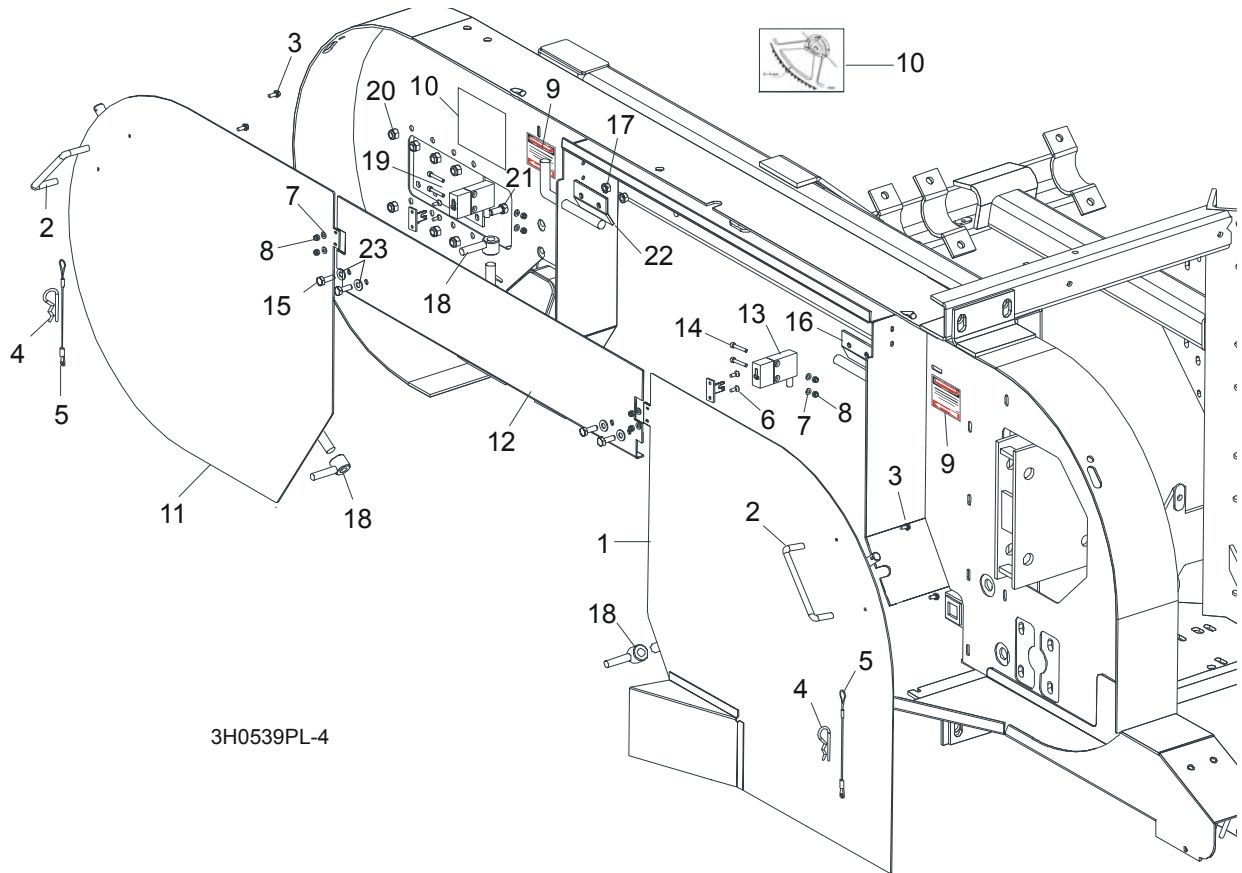

3H0539PL-4

REF	DESCRIPTION (◆ Indicates Parts Available In Assemblies Only)	PART #	QTY.	
	COVER ASSEMBLY, DRIVE SIDE BLADE HOUSING WITH HANDLE	087165	1	
1	Cover Weldment, Drive Side Blade Housing	087159-1	1	◆
2	Handle, Blade Housing Cover	P08065	1	
3	Screw, #8-32 x 3/8"	F05015-8	2	
	Pin Assembly, Cover Retainer	A11881	1	
4	Pin, Safety Retainer	N/A	1	
5	Cable, 3/64" x 6" Lanyard	N/A	1	
6	Bolt, M4 x 12-5.8	F81011-41	2	
7	Washer, 4.3	F81051-2	4	
8	Nut, M4 Hex	F81029-1	2	
9	DECAL, BLADE DANGER W/ARROW	S11751	2	
10	DECAL, BLADE SETTING	P85066	1	
	COVER, IDLE SIDE BLADE HOUSING WITH HANDLE	086431	1	
11	Cover, Idle Side Blade Housing	086430-1	1	◆
2	Handle, Blade Housing Cover	P08065	1	
3	Screw, #8-32 X 3/8" Self-Tap	F05015-8	2	

4

Saw Head

Blade Housing Covers

	Pin Assembly, Cover Retainer	A11881	1	
4	Pin, Safety Retainer	N/A	1	
5	Cable, 3/64" x 6" Lanyard	N/A	1	
8	Screw, M4 x 12-5.8	F81011-41	4	
9	Washer, 4.3 Flat	F81051-2	4	
10	Nut, M4 Hex	F81029-1	2	
12	COVER, MIDDLE BLADE HOUSING	087326-1	1	
13	Switch, Emergency Stop	087650	2	
14	Bolt, M4 x 20-8.8 Socket Head	F81011-31	4	
15	BOLT, 1/4-20 X 3/4" HEX HEAD	F05005-1	4	
16	HINGE, MIDDLE BLADE HOUSING COVER	S07522	1	
17	NUT, 1/4-20 SELF-LOCKING HEX	F05010-9	4	
18	NUT, COVER TURN	086365-1	2	
19	PLATE, IDLE BLADE WHEEL GUARD	086230	1	
20	NUT, 5/16-18 HEX NYLON LOCK	F05010-58	6	
21	BOLT, 5/16-18 X 3/4" HEX HEAD GRADE 2	F05006-5	6	
22	HINGE, MIDDLE BLADE HOUSING COVER	085336-1	1	
23	WASHER 6.4 ZINC	F81053-1	4	

4.9 Drive Belt Covers

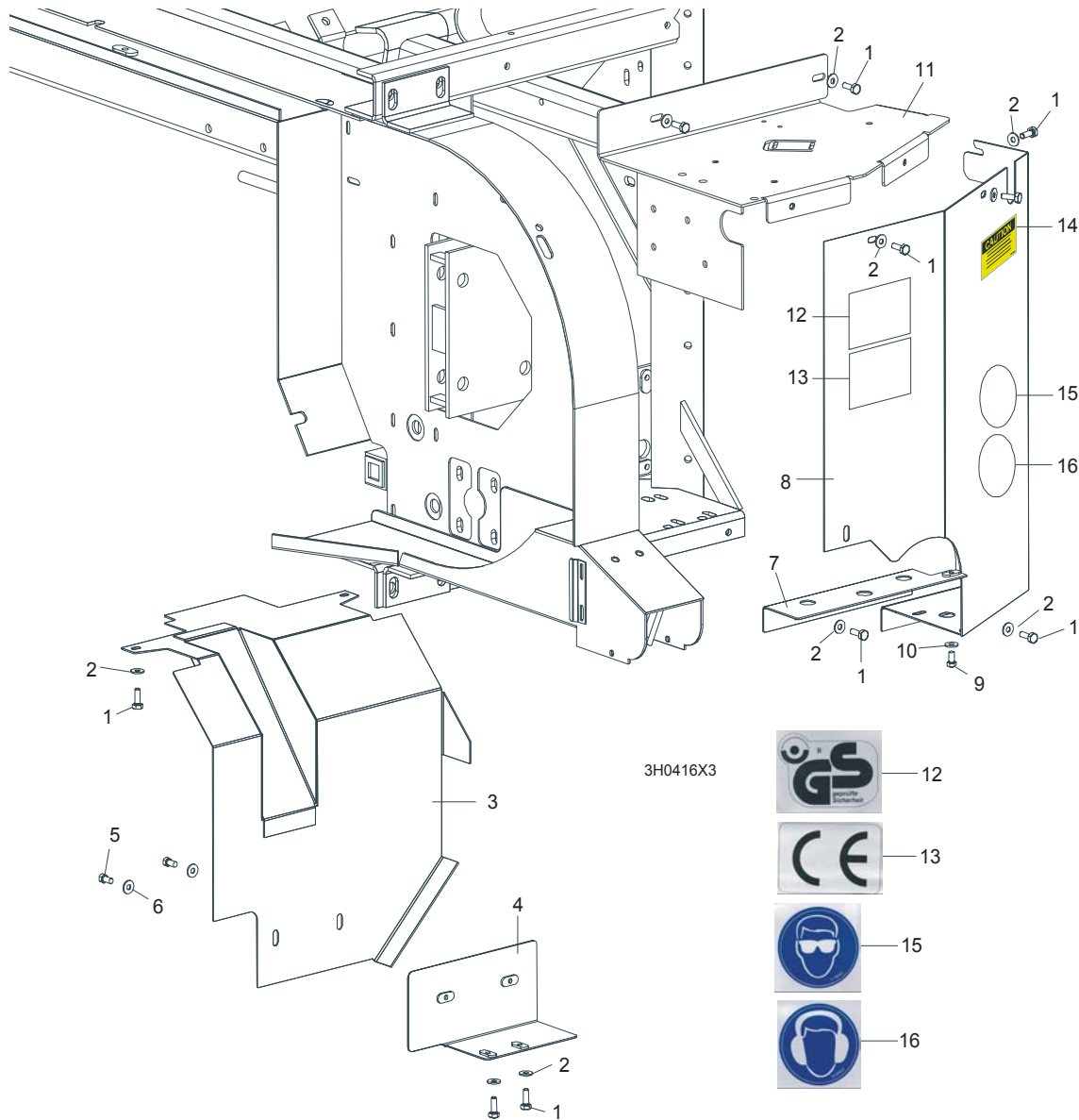

REF	DESCRIPTION (◆ Indicates Parts Available In Assemblies Only)	PART #	QTY.
1	BOLT, M6X12-8.8-ZINC	F81001-7	11
2	WASHER 6,5 ZINC	F81053-11	11
	GUARD ASSEMBLY, CLUTCH LEVER	086290 ¹	1
3	Guard Weldment, Manual Clutch	093398-1	1
4	Mount Weldment, Clutch Guard	086275-1	1
5	Bolt, M6X12-8.8 Hex Head Zinc	F81001-7	2
6	Washer, 6.5 Flat Zinc	F81053-11	2
	GUARD ASSEMBLY, DRIVE PULLEY SIDE	093396	1
7	Guard Weldment, Lower Up/Down	093395-1	1
8	Guard Weldment, C-Frame Enclosure	092572-1	1

4

Saw Head

Drive Belt Covers

9	Bolt, M6X12-8.8 Hex Head Zinc	F81001-7	1	
10	Washer, 6.5 Flat Zinc	F81053-11	1	
11	GUARD, DRIVE PULLEY TOP	087033-1	1	
12	DECAL, GS SAFETY CERTIFICATION	P85073	1	
13	DECAL, CE CRTIFIED SAWMILL	P85071	1	
14	DECAL, UP/DOWN MOVEMENT DANGER	A11762	1	
15	DECAL, EYE PROTECTION WARNING	S12004G	1	
16	DECAL, EAR PROTECTION WARNING	S12005G	1	

¹ Different belt guards required if sawmill is equipped with autoclutch option. See Section 5.3 of the Autoclutch Option manual.

4.10 Sawdust Chute

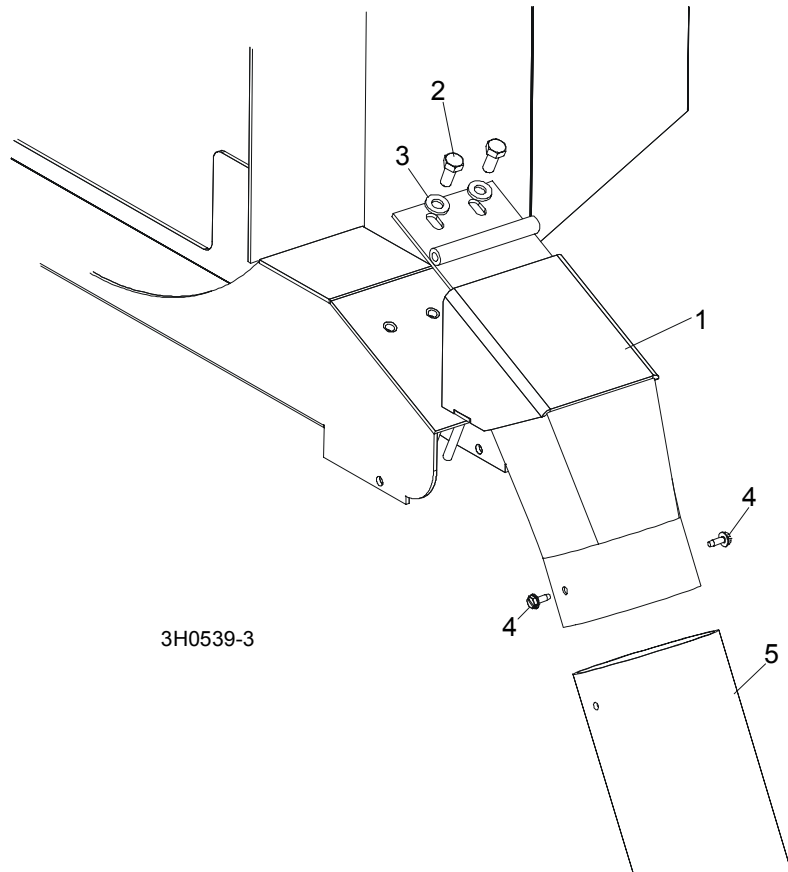

REF	DESCRIPTION (◆ Indicates Parts Available In Assemblies Only)	PART #	QTY.	
1	CHUTE WELDMENT, SAWDUST	092460-1	1	
2	BOLT, M8X20-8.8-B-ZINC HEX HEAD	F81002-20	2	
3	WASHER 8,4-ZINC ROUND	F81054-1	2	
4	BOLT, #10-24 X 1/2" SELF-TAPPING	F05015-7	2	
5	TUBING, 4" I.D. RUBBER	086364	0.6 m	
	STRAP, 20" RUBBER W/HOOK	P11668	1	
	BOLT, 1/4-20 X 1 1/4" HEX HEAD FULL THREAD	F05005-3	1	
	WASHER, 7.4 FLAT	F81056-11	1	
	NUT, 1/4-20 LOCK	F05010-21	1	

SECTION 5 CONTROL & BATTERY BOXES

5.1 Control Assembly, LT40 Series

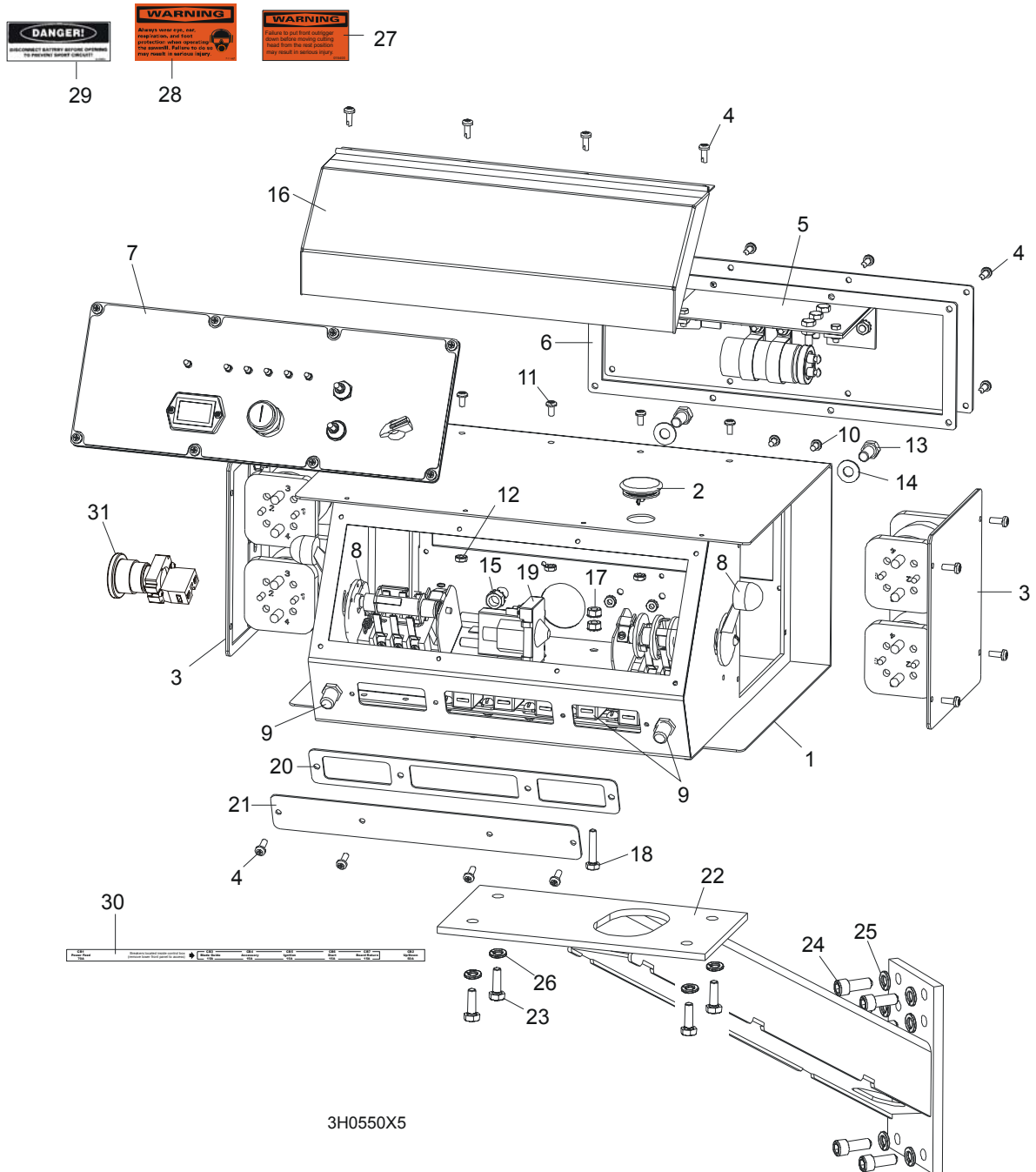

REF	DESCRIPTION (◆ Indicates Parts Available In Assemblies Only)	PART #	QTY.
	CONTROL BOX ASSEMBLY	086572	1

1	Box Weldment, Sawmill Control	086694-1	1	◆
2	Plug, AS075 Oiltite	E20570	1	
3	Solenoid Parts (See Section 5.4)			
4	Screw, #10-24 x 1/2" Pan Head	F05015-17	16	
5	Panel Assembly, Power Feed Control	024412	1	
6	Gasket, Rear Access Panel	015278	1	
	Control module assy, P/F SMT Service'97	024396-1	1	
	Module assy, mosfet 6X SMT Networks	024503	1	
7	Front Control Panel & Wiring Harnesses (Section 5.5)			
8	Drum Switches (Section 5.2)			
9	Circuit Breakers (Section 5.3)			
10	Screw, #10-24 x 3/8" Phillips Pan Head	F05004-3	2	
11	Screw, #10-24 x 3/8" Phillips Pan Head Machine with Neo Washer	F05004-148	4	
12	Nut, #10-24 Self Locking	F05010-14	6	
13	Bolt, 3/8-16 x 3/4" Hex Head	F05007-27	2	
14	Washer, 10.5 Flat	F81055-1	2	
15	Nut, 3/8" Lock Nut	F05010-19	2	
16	Cover, Control Box Hinged	015304	1	
17	Nut, 1/4-20 Self Locking	F05010-9	2	
18	Bolt, 1/4-20 x 1 1/4" Hex Head Tap	F05005-3	1	
19	Solenoid, Accessory	P10449	1	
20	Gasket, Front Access Panel	015266	1	
21	Panel, Control Box Front Access	086704-1	1	
22	MOUNT WELDMENT, STANDARD CONTROL BOX	086732-1	1	
23	BOLT, M8X20-8.8-B HEAD HEX ZINC	F81002-4	4	
24	BOLT, M10 X 25-8.8 SOCKET HEAD	F81003-32	6	
25	WASHER, 10.2 SPLIT LOCK	F81055-2	6	
26	WASHER, 8.4 FLAT	F81054-1	4	
27	DECAL, FRONT OUTRIGGER WARNING	015400	1	
28	DECAL, EAR/EYE PROTECTION WARNING	S11753	1	
29	DECAL, DISCONNECT BATTERY DANGER	S12002	1	
30	DECAL, CIRCUIT BREAKER ID ('98 SUPER)	024362	1	
31	SWITCH, RED EMERGENCY STOP XB4 BS542	086556	1	

5.2 Drum Switches

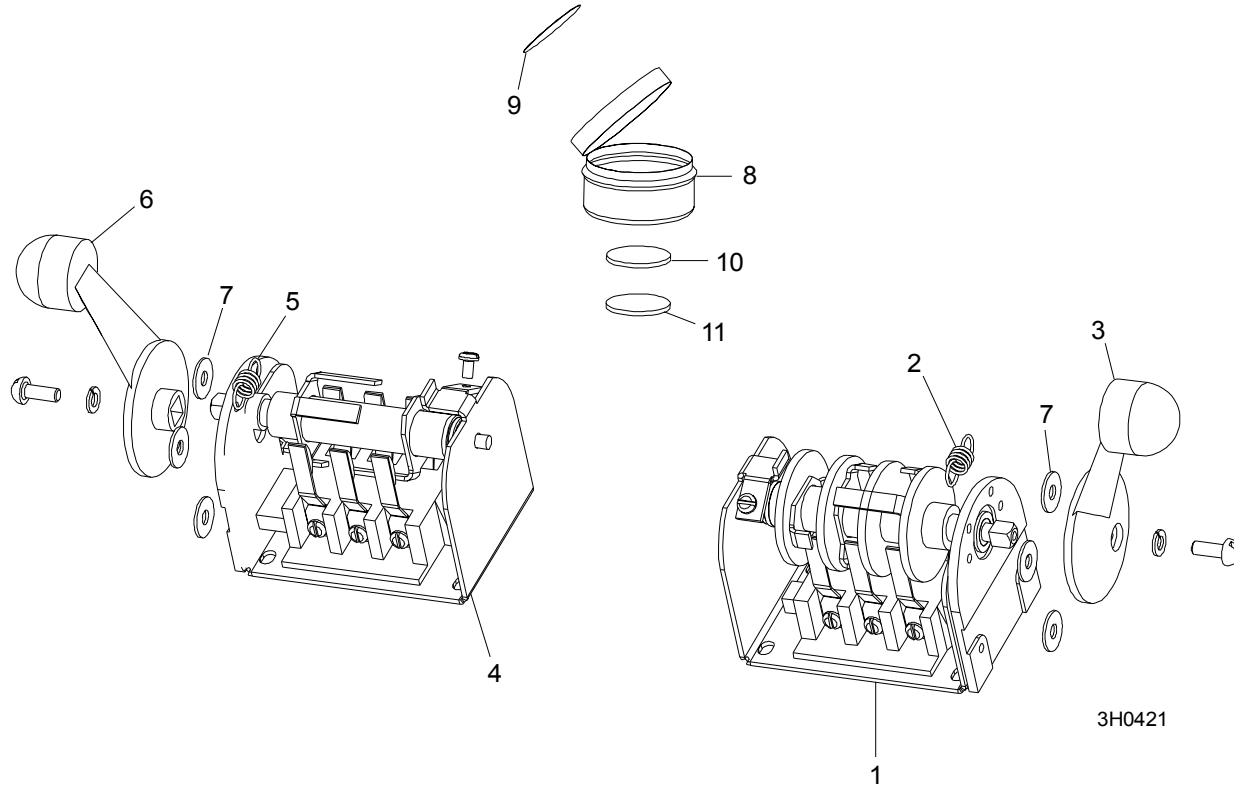

REF	DESCRIPTION (◆ Indicates Parts Available In Assemblies Only)	PART #	QTY.	
	SWITCH ASSEMBLY, UP/DOWN DRUM	E20440	1	
1	Switch, S12 Bulk Drum	E20440-B	1	◆
2	Spring, Drum Switch	P12570	1	
3	Handle, Drum Switch Replacement	P12500	1	
	SWITCH ASSEMBLY, POWER FEED DRUM	E20438	1	
4	Switch, S10 Bulk Drum	E20438-B	1	◆
5	Spring, Drum Switch	P12570	1	
6	Handle, Drum Switch Replacement	P12500	1	
7	WASHER, #8 SAE FLAT	F05011-41	6	
	CUP ASSEMBLY, DRUM SWITCH GREASE	A20463	1	
8	Cup, Plastic Container	P20464	1	◆
9	Decal, Grease Cup Label	P20467	1	
10	Pad, Velcro Loop	P20466	1	◆
11	Pad, Velcro Hook	P20465	1	◆
	Grease, High Temp Drum Switch	P20468	.011m	◆

5.3 Circuit Breakers

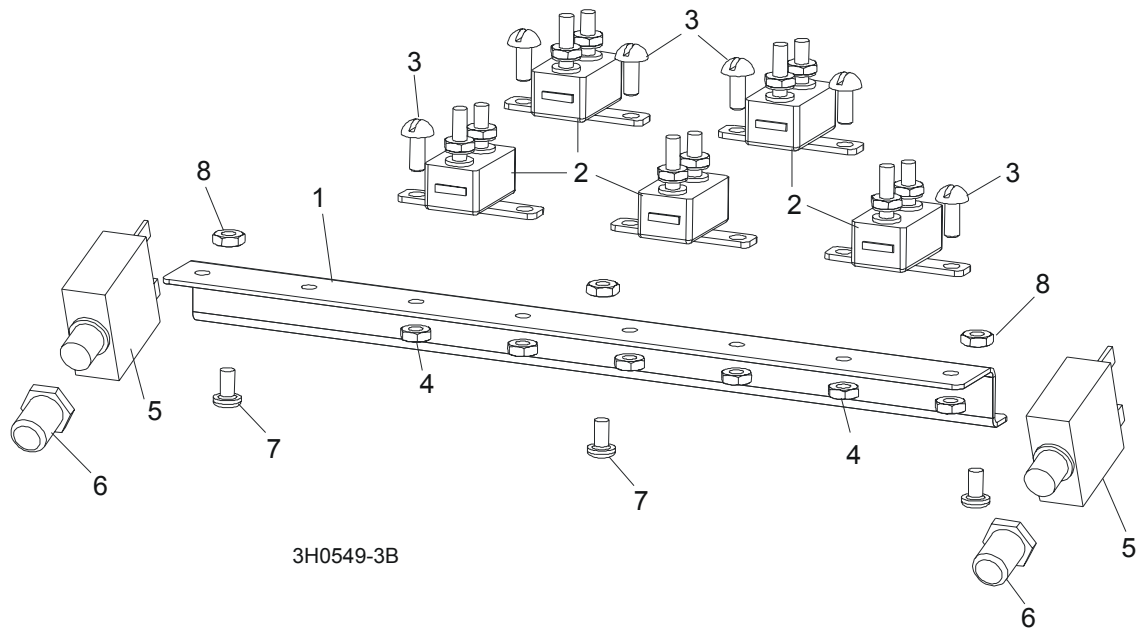

REF	DESCRIPTION (◆ Indicates Parts Available In Assemblies Only)	PART #	QTY.
	BREAKER ASSEMBLY, SAWMILL CONTROL CIRCUIT	015621	1
1	Rail, Circuit Breaker	015310	1
2	Breaker, 15 Amp Manual Reset	E20430	5
3	Screw, H M5x10 8.8 Slotted Head Zinc	F81000-13	6
4	Nut, M5-8 Hex Self-Locking Zinc	F81030-2	6
5	BREAKER, 70 AMP MANUAL RESET PANEL MOUNT	015527	2
6	BOOT, CIRCUIT BREAKER	021253	2
7	BOLT, M5X12-5.8 ZINC	F81000-5	3
8	NUT, M5-8 SELF LOCKING ZINC	F81030-2	3

5.4 Solenoid Assemblies

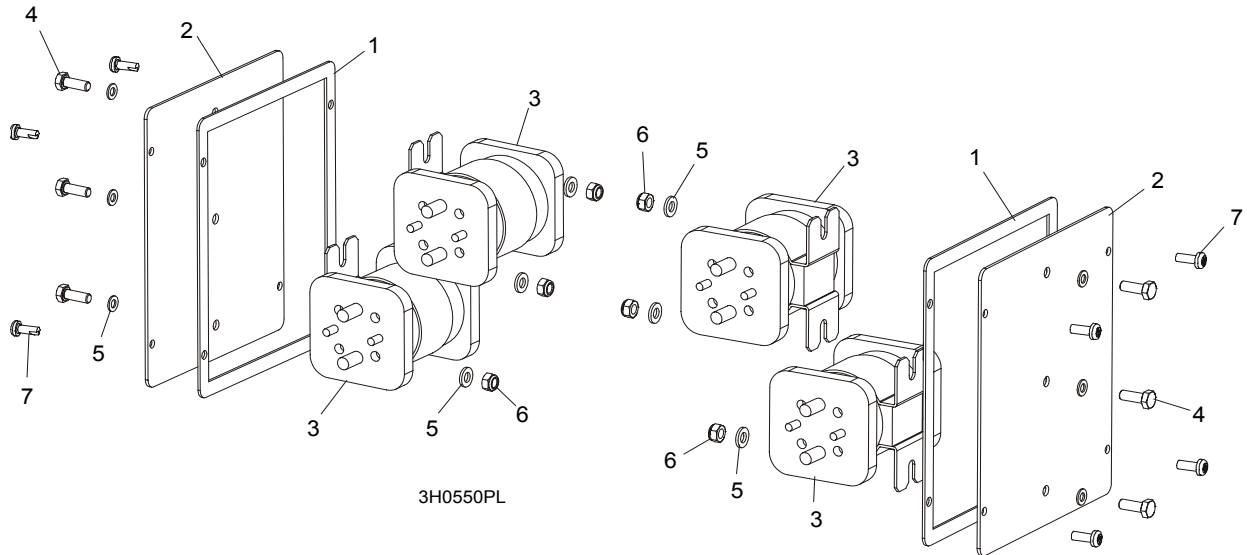

REF	DESCRIPTION (◆ Indicates Parts Available In Assemblies Only)	PART #	QTY.
1	GASKET, SIDE PANEL CONTROL	015274	2
2	PANEL WELDMENT, SIDE	086699-1	2
3	SOLENOID, 200A 12V DPST	015417	4
4	BOLT, M6 X 16-5.8 HEX HEAD	F81001-14	6
5	WASHER, 6.4 FLAT	F81053-1	12
6	NUT, M6-8 HEX	F81031-2	6
	DIODE ASSEMBLY, SOLENOID COIL CHASSIS GND	087496	4
7	SCREW, #10-24 X 1/2" PAN HEAD	F05015-17	8

5.5 Front Panel Assembly & Harnesses

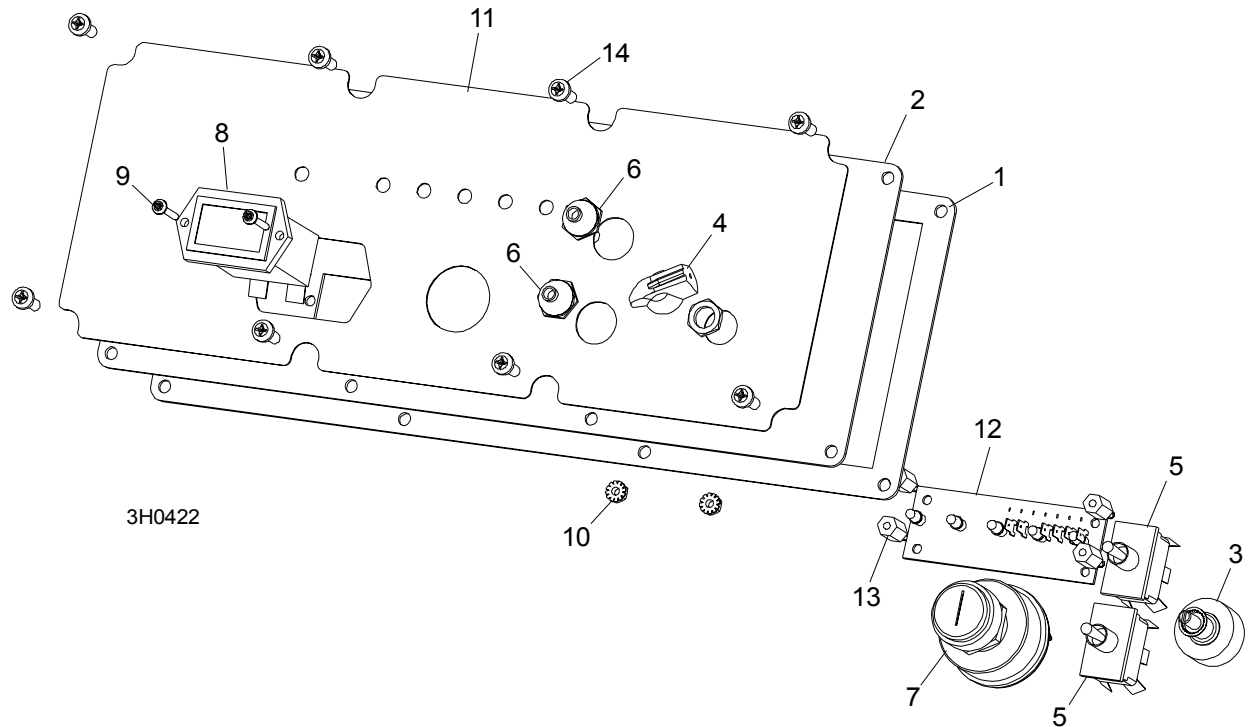

REF	DESCRIPTION (◆ Indicates Parts Available In Assemblies Only)	PART #	QTY.
	PANEL ASSEMBLY, CONTROL FRONT	087401	1
1	Gasket, Front Panel	088387	1
2	Panel Weldment, Control	015302	1
3	Switch Assembly, Feed Rate	E20519	1
4	Knob, Feed Rate With Set Screw	P06257	1
5	Switch, Toggle	024200	2
6	Boot, Toggle Switch Rubber	P02575	2
7	Switch, Key	P04350	1
8	Meter, Hour	015401	1
9	Bolt, M3x12 -8.8 Zinc	F81000-12	2
10	Nut, M3-6 Self Locking Zinc	F81028-2	2
11	Decal, Control Panel	015269	1
12	Board, LED Circuit	089694	1
13	Spacer, 1/2" #6 Threaded	023147	4
	HARNESS ASSEMBLY, UPPER WIRING	087107	1
	HARNESS ASSEMBLY, LOWER WIRING	087108	1
14	Screw, #10-24 x 1/2" Pan Head	F05015-17	8

5.6 Battery Box Assembly, LT40 Series

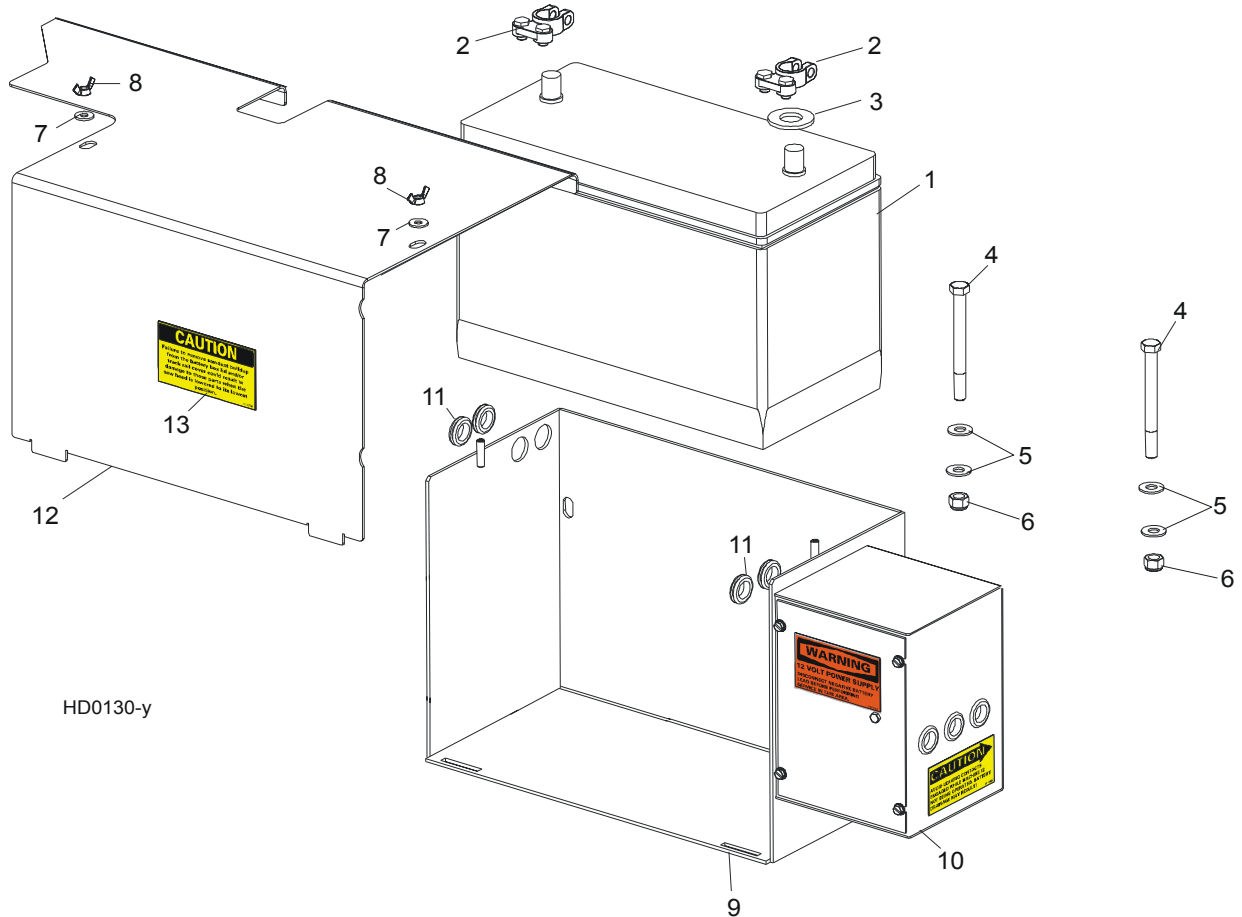

REF	DESCRIPTION (◆ Indicates Parts Available In Assemblies Only)	PART NUMBER	QTY.
1	BATTERY, "BANNER" 12V100AH #95751	088323	1
	BOX ASSEMBLY, LT40SHD/LT40MHD BATTERY	086509	1
2	Terminal, Battery	P05085	2
3	Washer, Battery Terminal	P12161	1
4	Bolt, 3/8-16 X 4" Hex Head Grade 2	F05007-4	2
5	Washer, 10.5 Flat	F81055-1	4
6	Nut, 3/8" Hex Nylon Lock	F05010-10	2
7	Washer, 7.4 Flat	F81056-11	2
8	Nut, 1/4-20 Wing	F05010-13	2
9	Box Weldment, Battery	086265-1	1
10	Fuse Box Parts (See Section 5.7)		
11	Grommet, 5/8" Rubber Wire	P11764	5
	Contact Assembly, Hydraulic Positive (See Section 9.3)	085968	1
12	LID WELDMENT, BATTERY BOX SUPER	086277-1	1
13	DECAL, BATTERY BOX LID CAUTION	014774	1

5.7 Fuse Box Assembly, LT40 Series

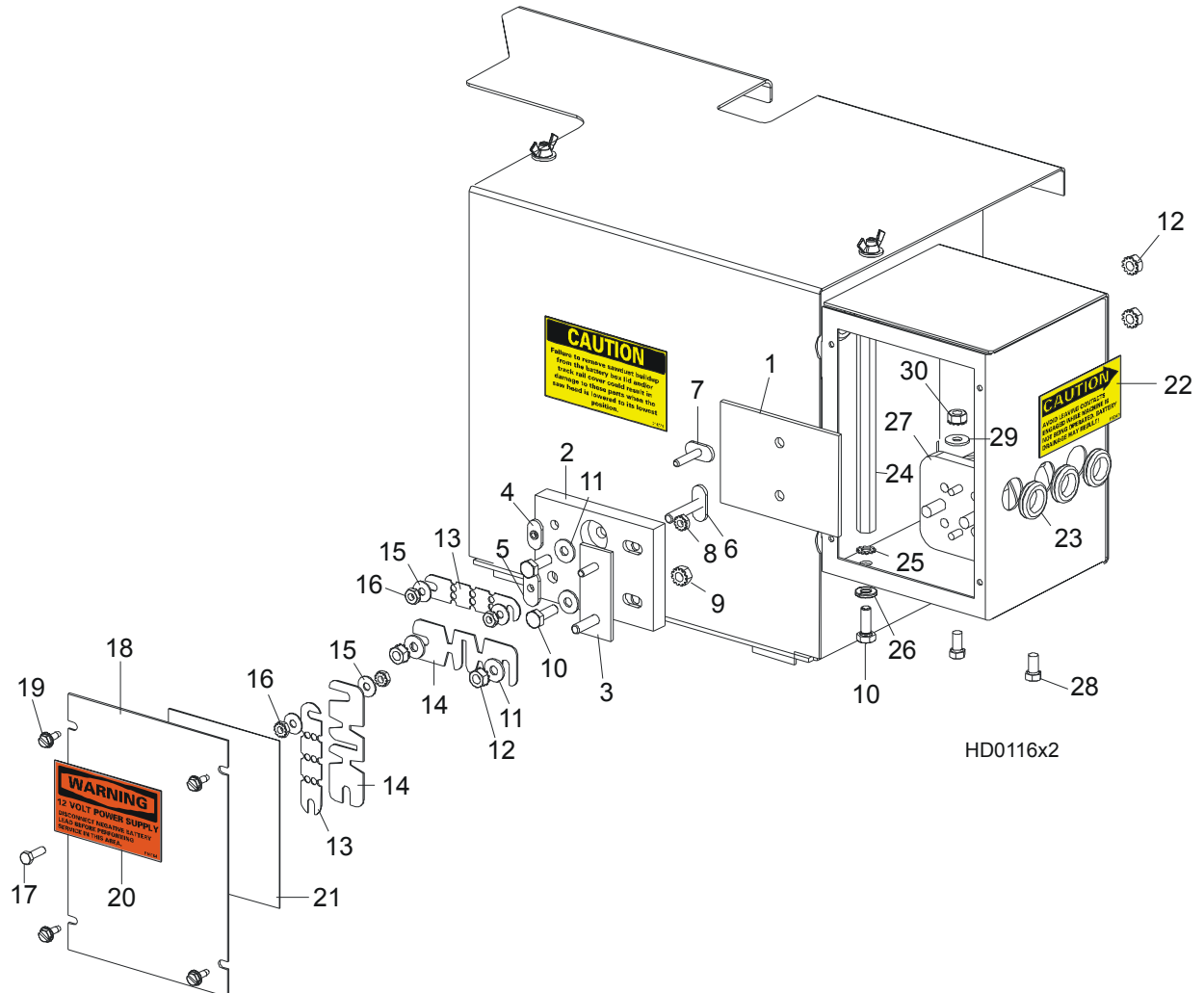

REF	DESCRIPTION (◆ Indicates Parts Available In Assemblies Only)	PART NUMBER	QTY.	
1	PAD, FUSE BOX INSULATOR	015287	1	
	FUSE BLOCK ASSEMBLY	017665	1	
2	Block, Fuse Mount	015286	1	◆
3	Buss Weldment, Fuse Mount	015289	1	◆
4	Nut, #10-24 Cadmium Plated Weld	S12391	1	◆
5	Nut, 1/4-20 Cadmium Plated Weld	S12392	1	◆
6	Stud Weldment, 1/4-20 Fuse	W12389	1	◆
7	Stud Weldment, #10-24 Fuse	W12390	1	◆
8	Nut, #10-24 Self-Locking Hex	F05010-14	1	◆
9	Nut, 1/4-20 Self-Locking Hex	F05010-9	1	◆
10	BOLT, 1/4-20 X 3/4" HEX HEAD FULL THREAD	F05005-1	3	
11	WASHER, 7.4 FLAT	F81056-11	4	
12	NUT, 1/4-20 HEX SELF-LOCKING	F05010-9	4	
13	FUSE LINK, 12 VOLT 150 AMP	023361	2	

5

Control & Battery Boxes*Fuse Box Assembly, LT40 Series*

14	FUSE LINK, 12 VOLT 225 AMP	P11550	2	
15	WASHER, 5.3 FLAT	F81052-1	4	
16	NUT, #10-24 HEX SELF-LOCKING	F05010-14	4	
17	SCREW, #10-24 X 5/8" HEX HEAD	F05004-18	1	
18	COVER, FUSE BOX	086272-1	1	
19	SCREW, #10-24 X 1/2" SELF-TAPPING	F05015-7	4	
20	DECAL, 12 VOLT WARNING	P10364	1	
21	DECAL, '97 SUPER HYDRAULIC	015372	1	
22	DECAL, HYDRAULIC CONTACT CAUTION	P12960	1	
23	GROMMET, 5/8" RUBBER WIRE	P11764	3	
24	TERMINAL, EXTENDED HEX STUD	015517	1	
25	WASHER, 6.4 EXTERIOR STAR	F81053-2	1	
26	WASHER, 6.1 SPLIT LOCK	F81053-3	1	
27	SOLENOID, 200A 12V SPST CONT. DUTY	015470	1	
28	BOLT, 1/4-20 X 1/2" HEX HEAD	F05005-15	2	
29	WASHER, 7.4 FLAT	F81056-11	2	
30	NUT, 1/4-20 SELF-LOCKING HEX	F05010-9	2	

SECTION 6 UP/DOWN SYSTEM

6.1 Saw Head V-Brace Mount

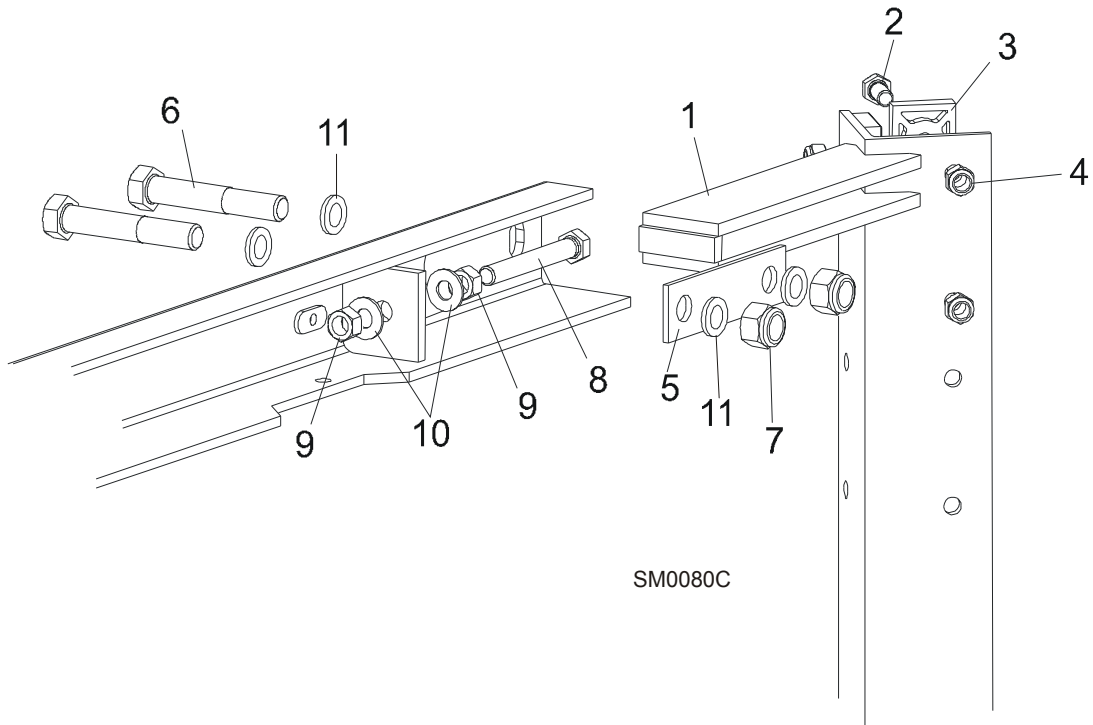

REF	DESCRIPTION (◆ Indicates Parts Available In Assemblies Only)	PART #	QTY.
1	V-BRACE, SAW HEAD MOUNT	087125	1
2	BOLT, M8X20-5.8-ZINC HEX HEAD	F81002-4	10
	BOLT, M8X25-8.8-B-ZINC HEX HEAD	F81002-5	2
3	PAD, PLASTIC SLIDE	M04096	6
4	NUT, M8-8-B-ZINC HEX NYLON LOCK	F81032-2	12
5	PLATE, V-BRACE WASHER	091247	2
6	BOLT, M12X75-8.8-ZINC	F81004-21	4
7	NUT, M12 - 8 NYLON LOCK	F81034-2	4
8	BOLT, M10X70-8.8-ZINC HEX HEAD	F81003-20	2
9	NUT, M10-8-B-ZINC HEX	F81033-3	4
10	WASHER, 10.5 FLAT	F81055-1	4
11	WASHER, 13 SPLIT LOCK ZINC	F81056-1	8

6.2 Blade Height Scale

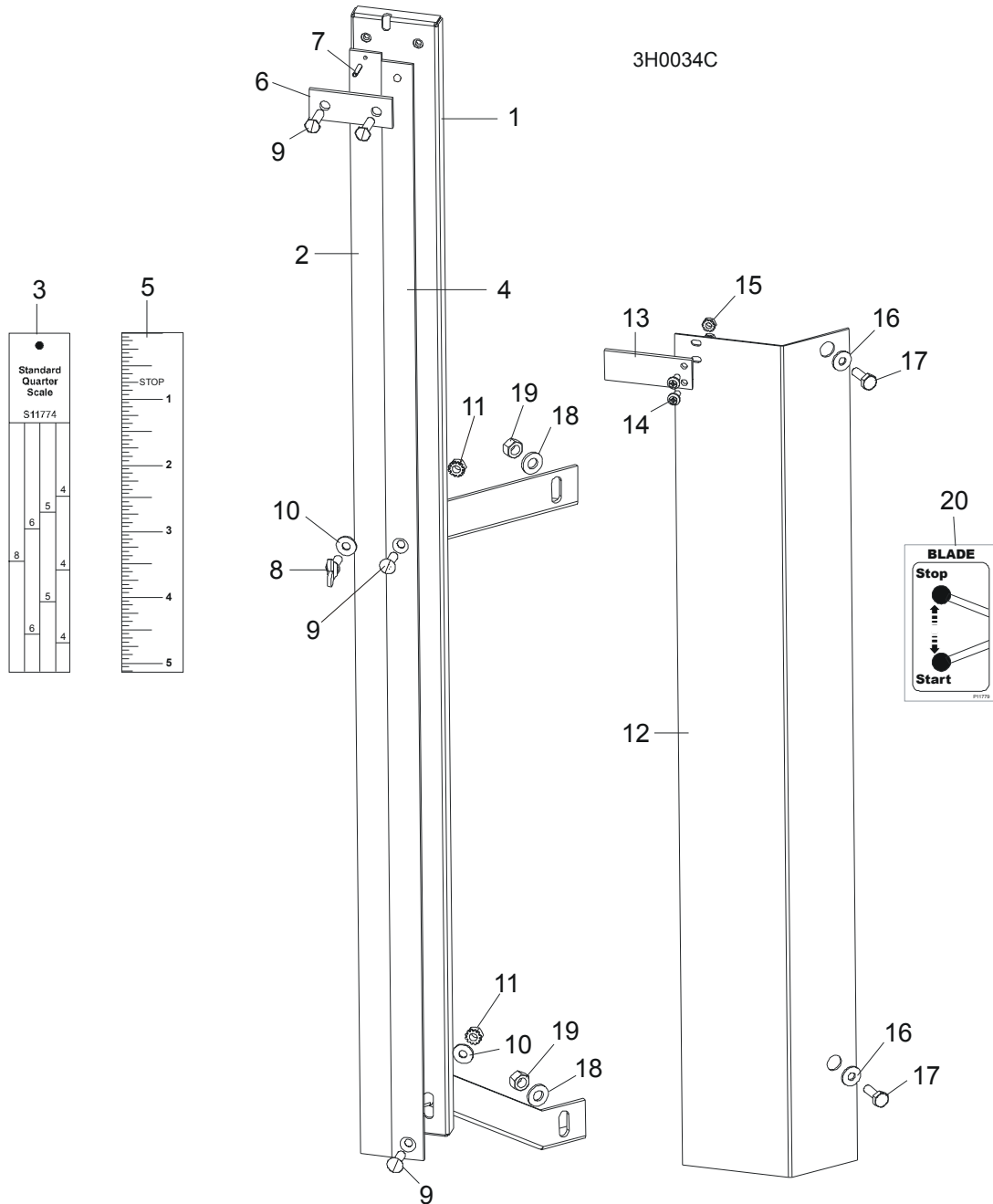

REF	DESCRIPTION (◆ Indicates Parts Available In Assemblies Only)	PART #	QTY.
	SCALE, BLADE HEIGHT	093366	1
	SCALE, BLADE HEIGHT INCH	093361	1
1	Bracket, Scale Mounting	093365-1	1
2	Scale, 35" Quarter	093342	1
3	Decal, 35" Standard Quarter Scale	090716	1
	Decal, 35" Grade Hardwood Quarter Scale	090717	1

4	Scale, 35" Inch	093341	1	
5	Decal, 35" Inch	090709	1	
6	Strap, Scale Hold-Down	093134	1	
7	Pin, 3x20 Roll	F81044-5	1	
8	Screw, M6x16 Wing	F81001-16	1	
9	Screw, M6x20- 4.8-B	F81001-31	4	
10	Washer, 6.5 Flat	F81053-11	2	
11	Nut, M6, Hex, Nylon Lock Zinc	F81031-2	4	
	Pointer Assembly, Fixed Scale	A12023	1	
12	Bracket, Fixed Scale Pointer Mount	087044-1	1	◆
13	Pointer, Fixed Scale	086691	1	
14	Screw, #10-24 X 3/8" Phillips Head	F05004-3	2	
15	Nut, #10-24 Hex Self-Locking	F05010-14	2	
16	Washer, 6.5 Flat	F81053-11	2	
17	Bolt, M6x12-8.8-Zinc	F81001-7	2	
18	Washer, 8.4 Flat	F81054-1	2	
19	Nut, M8-8-B Hex Lock	F81032-2	2	
	Bolt, 1/4-20 X 1/2" Hex Head Grade 2	F05005-15	1	
	Instruction Sheet, Fixed Scale Retrofit	A12030-370	1	
	DECAL KIT, METRIC SCALE	K12064	1	
	Decal, Metric	S11711	1	
	Decal, Metric 16-40mm	P12040-1	1	
	Decal, Metric 45-63mm	P12040-2	1	
20	DECAL, CLUTCH HANDLE OPERATION	P11779	1	

6.3 Up/Down Chain & Sprockets

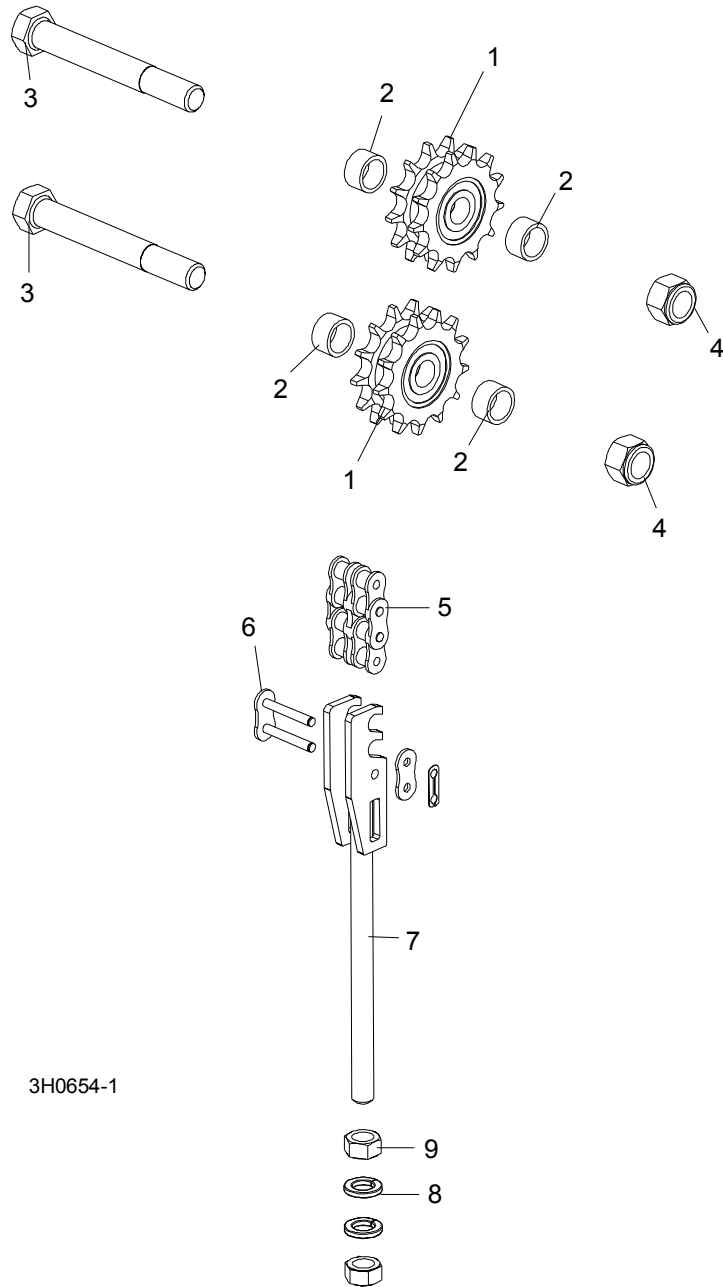

3H0654-1

REF	DESCRIPTION (◆ Indicates Parts Available In Assemblies Only)	PART #	QTY.
	SPROCKET KIT, UP/DOWN IDLER #50-2	016020	1
1	Sprocket, Up/Down Idler '98	016019	2
2	Spacer, 50-2 Idler '98	016018	4
	Instruction Sheet, Up/Down Idler Retrofit	016020-541	1
3	BOLT, 5/8-11 X 5" HEX HEAD GRADE 2	F05009-6	2

4	NUT, 5/8-11 HEX NYLON LOCK	F05010-34	2	
5	CHAIN, #50-2 X 75.625" UP/DOWN	015259	1	
6	LINK, #50-2 MASTER	015258	2	
	TENSIONER ASSEMBLY, UP/DOWN CHAIN	086219	1	
7	Bracket, Up/Down #50 Chain Tensioner	086205-1	1	◆
8	Washer, 12.2 Split Lock	F81056-2	2	
9	Nut, M12-8-B Hex	F81034-1	2	

6.4 Up/Down Motor Assembly, LT40 Series

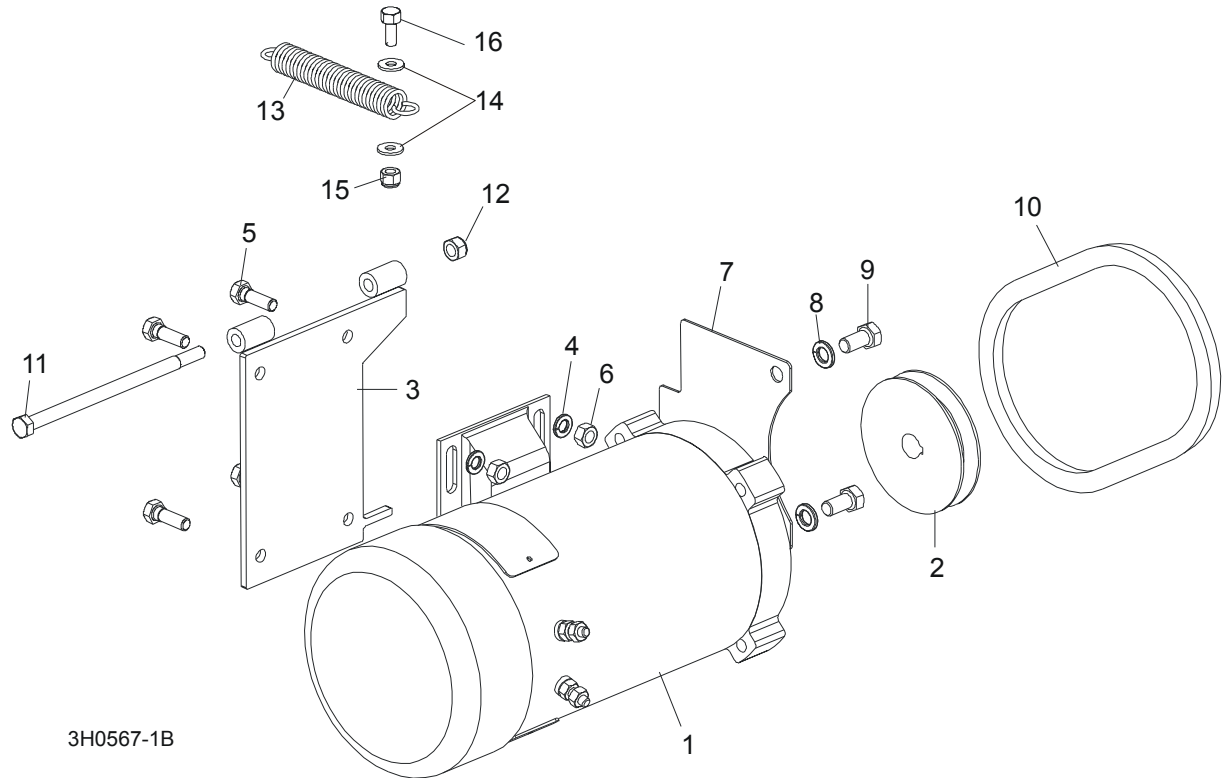

REF	DESCRIPTION (◆ Indicates Parts Available In Assemblies Only)	PART #	QTY.
	UP/DOWN MOTOR ASSEMBLY	092818	1
1	Motor, 3/4 HP Electric	015174	1
	Brush Kit, Power Feed Motor (Includes 2 Brushes and 2 Springs)	024167	1
	Fan, 3/4 HP Leeson Motor Replacement	016087	1
2	Pulley, AK20X5/8" BORE	036179	1
3	Bracket, Up/Down Motor Mount	015198	1
4	Washer, M8, Flat, Zinc	F81054-1	4
5	Bolt, M8x20mm, Hex Head, Gr 5.8 Zinc	F81002-4	4
6	Nut, M8, Hexagon, Nylon Lock Zinc	F81032-2	4
7	Guard, Up/Down Sprocket	015016	1
8	Washer, 10.2 Split Lock	F81055-2	2
9	Bolt, 3/8-16 x 3/4" Hex Head	F05007-27	2
10	BELT, 4L230 (GOOD-YEAR)	036205	1
11	BOLT, 5/16-18 X 6" HEX HEAD GRADE 5	F05006-73	1
12	NUT, 5/16-18 NYLON LOCK	F05010-58	1
13	SPRING, .75" X 5" X .095" EXTENSION	015569	1
14	WASHER, 6.5 FLAT ZINC	F81053-11	2
15	NUT, M6-8-B NYLON LOCK HEX ZINC	F81031-2	2
16	BOLT, M6x25-8.8 ZINC	F81001-20	1

6.5 Up/Down Drive Assembly, LT40 Series

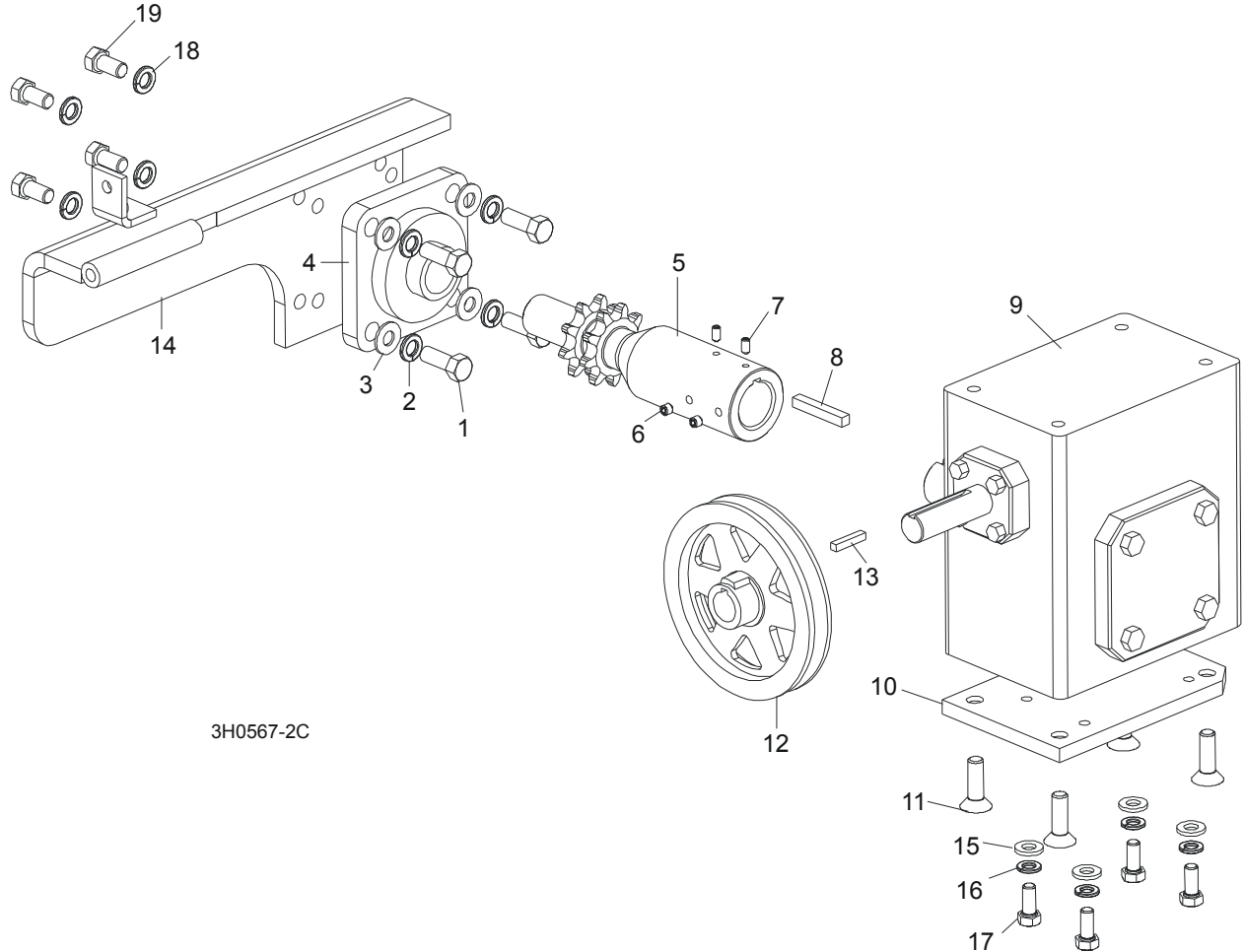

3H0567-2C

REF	DESCRIPTION (◆ Indicates Parts Available In Assemblies Only)	PART #	QTY.	
	UP/DOWN DRIVE ASSEMBLY	092817	1	
1	Bolt, 3/8-16 x 1" Hex Head	F05007-7	4	
2	Washer, 10.2 Split Lock	F81055-2	4	
3	Washer, 10.5 Flat	F81055-1	4	
4	Bearing, Flanged Up/Down	014090	1	
5	Shaft, Up/Down Sprocket	092816-1	1	
6	Screw, M8 x 8-33H	F81014-1	2	
7	Screw, M8 x 8-33H	F81014-1	2	
8	Key, 1/4" Square x 1 11/16" Long	S04124	1	
9	Reducer, Gear Box	014074	1	
10	Plate, Gear Box Spacer	014158-1	1	
11	Bolt, 3/8-16 x 1" Flat Socket Head	F05007-110	4	
12	Pulley, Up/Down	015256	1	
13	Key, 3/16" Square x 1" Long	S31027	1	
14	Bracket, Up/Down Motor Mount	015195-1	1	

6**Up/Down System***Up/Down Drive Assembly, LT40 Series*

15	WASHER, 8.4 FLAT	F81054-1	8	
16	WASHER, 8.2 SPLIT LOCK	F81054-4	4	
17	BOLT, 5/16-18 X 1" HEX HEAD	F05006-5	4	
18	WASHER, 10.5 SPLIT LOCK	F81055-1	4	
19	BOLT, 3/8-16 X 3/4" HEX HEAD	F05007-27	4	
	OIL, 8 OZ. MOBIL SHC634 BOTTLED SYNTHETIC GEAR	L04869-4	1	

SECTION 7 POWER FEED & TRACK ROLLERS

7.1 Upper Track Rollers And Wipers

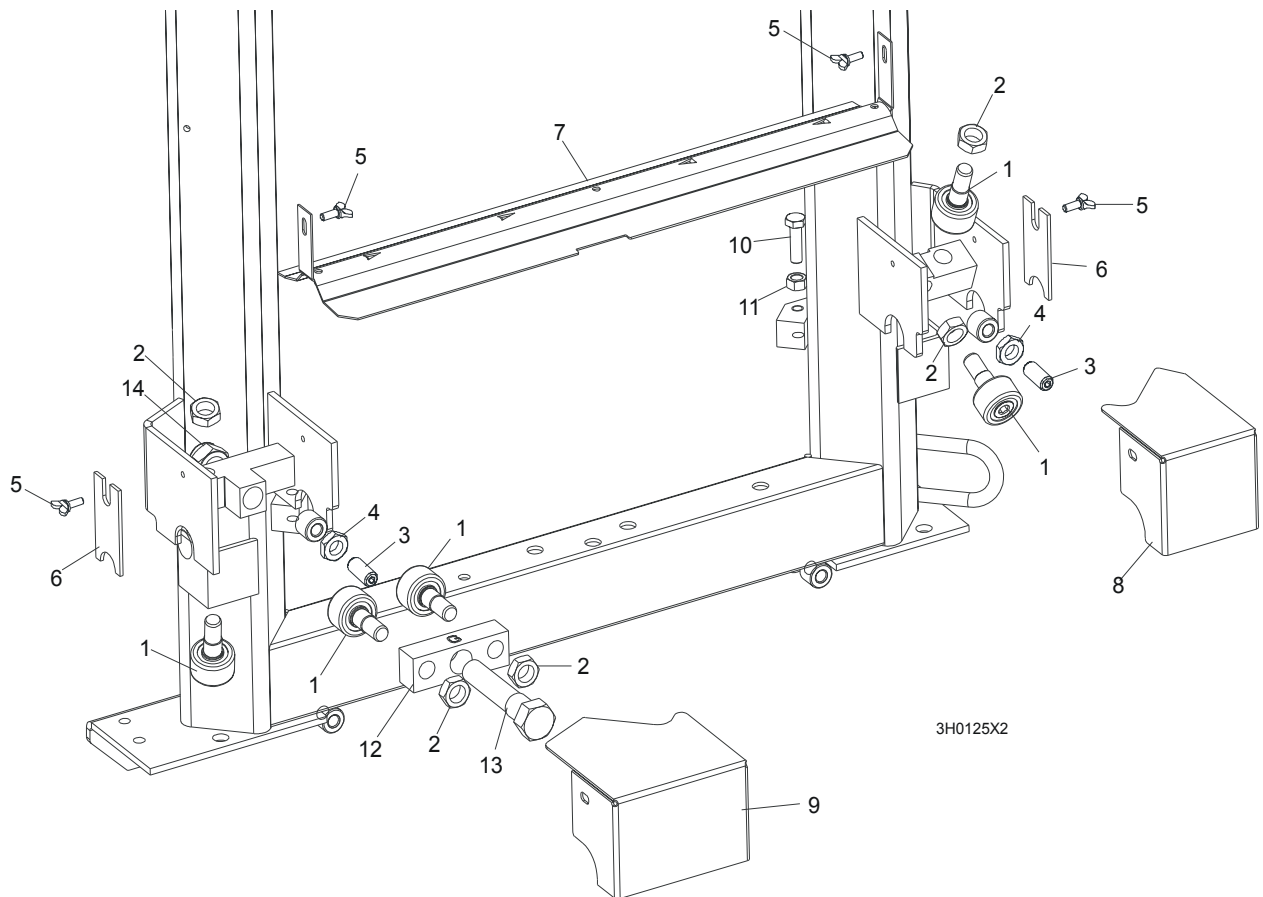

REF	DESCRIPTION (◆ Indicates Parts Available In Assemblies Only)	PART #	QTY.
1	ROLLER, TRACK CAM BEARING (MCGILL)	012797	5
2	NUT, 5/8-18 HEX JAM	F05010-11	5
3	SCREW, M12 X 30 OVAL POINT SET	F81004-14	2
4	NUT, M12-8-B HEX JAM	F81034-1	2
5	SCREW, M6 X 16 THUMB	F81001-16	4
6	WIPER, PLASTIC TRACK	M04113	2
7	COVER, MIDDLE TRACK OILER	S09917	1
	Wiper, Middle Track Felt	S09915	1
8	HOUSING, UPPER TRACK ROLLER REAR	086913-1	1
9	HOUSING, UPPER TRACK ROLLER FRONT	086914-1	1
10	BOLT, M10 X 35-8.8 HEX HEAD	F81003-17	2
11	NUT, M10-8 HEX JAM	F81033-3	2
12	BRACKET, UPPER TRACK ROLLER	086859-1	1
13	BOLT, HEX HEAD	086911	1
14	NUT, M20-8 HEX	F81037-2	1

7 Power Feed & Track Rollers

Power Feed Assembly,

7.2 Power Feed Assembly,

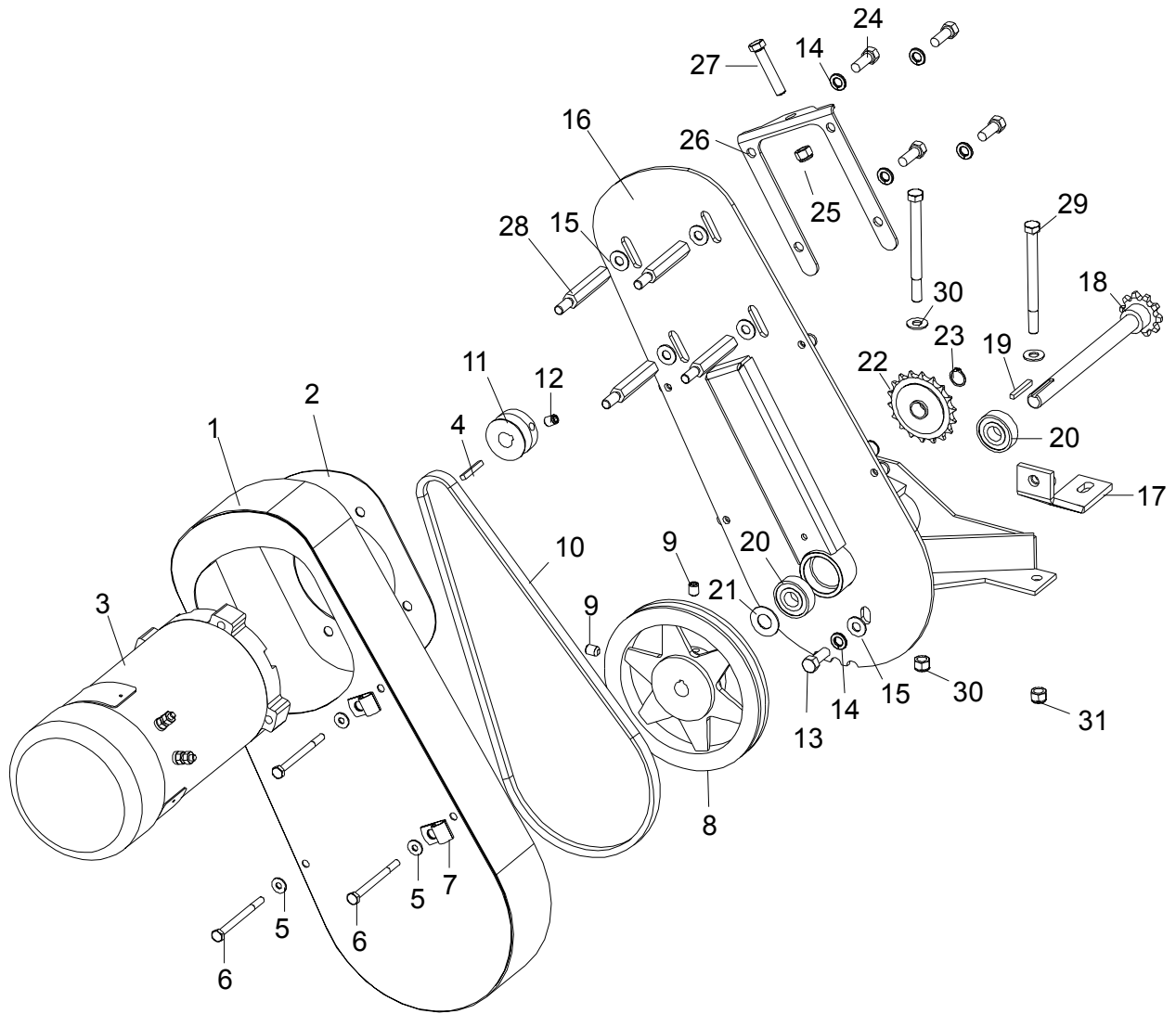

3H0619-2

REF	DESCRIPTION (◆ Indicates Parts Available In Assemblies Only)	PART #	QTY.
	POWER FEED ASSEMBLY	015125	1
1	Cover Weldment, Top Power Feed	015126	1
2	Plate, Power Feed Motor	015133	1
3	Motor, 3/4HP Power Feed Painted	024169	1
	Brush Kit, Leeson 3/4HP Motor (Includes 2 Brushes and 2 Springs)	024167	1
	Fan, 3/4 HP Leeson Motor Replacement	016087	1
4	Key, 3/16" Square x 1 3/8" Long	016109	1
5	Washer, 6.5 Flat	F81053-11	4
6	Bolt, M6x80 Hex Head Zinc	F81001-61	4

7	Clamp, 1/2" EMT Coated	P07584	2	
8	Sheave, AK71 x 5/8" Power Feed (200ft./min.)	016088 ¹	1	
9	Screw, 5/16-18 x 3/4" Cup Point Set	F05006-32	2	
10	Belt, AX36 (200ft./min.)	016083 ¹	1	
11	Sheave, 1 3/4" Feed Motor	015135	1	
12	Screw, 3/8"-16 x 1/2" Cup Point Set	F05007-12	1	
13	Bolt, M10x25-8.8 Hex Head Zinc	F81003-11	1	
14	Washer, 10.2 Split Lock	F81055-2	5	
15	Washer, 10.5 Flat	F81055-1	5	
16	Bracket, Power Feed Mount	015162-1	1	
17	Brace Weldment, Power Feed Mounting	086554-1	1	
	Shaft Assembly, Power Feed with Key	016066	1	
18	Shaft Weldment, Power Feed	015129	1	◆
19	Key, 3/16" Square x 1 3/8" Long	016108	1	
20	Bearing, 5/8" 6203-2NSL	P06030-1	2	
21	Washer, 5/8" x 15/16" x .094" Nylon	F05011-19	1	
22	Sprocket, 40 Idler 18T 5/8" ID	P04333	1	
23	Ring, Z15 Outer Retaining	F81090-2	1	
24	Bolt, 3/8-16 x 3/4" Hex Head	F05007-27	4	
25	Nut, 3/8-16 Hex Nylon Lock	F05010-10	1	
26	Plate, Belt Tensioner	015134	1	
27	Bolt, 3/8-16 x 2" Full Thread Hex Head	F05007-16	1	
28	Spacer, Power Feed Motor	015136	4	
29	BOLT, 3/8-16 X 4 1/2" HEX HEAD	F05007-35	2	
30	WASHER, 10.5 FLAT	F81055-1	4	
31	NUT, 3/8-16 HEX NYLON LOCK	F05010-10	2	

¹ Use kit 016085 to increase feed return rate to 220 ft./min. Kit includes AK64 sheave 016114, AX35 belt 015175, and instructions. Use kit 016070 to reduce feed return rate to 183 ft./min. Kit includes AL84 sheave 016115, AX38 belt 016068, and instructions.

7.3 Feed Chain/Stop, LT40 Series

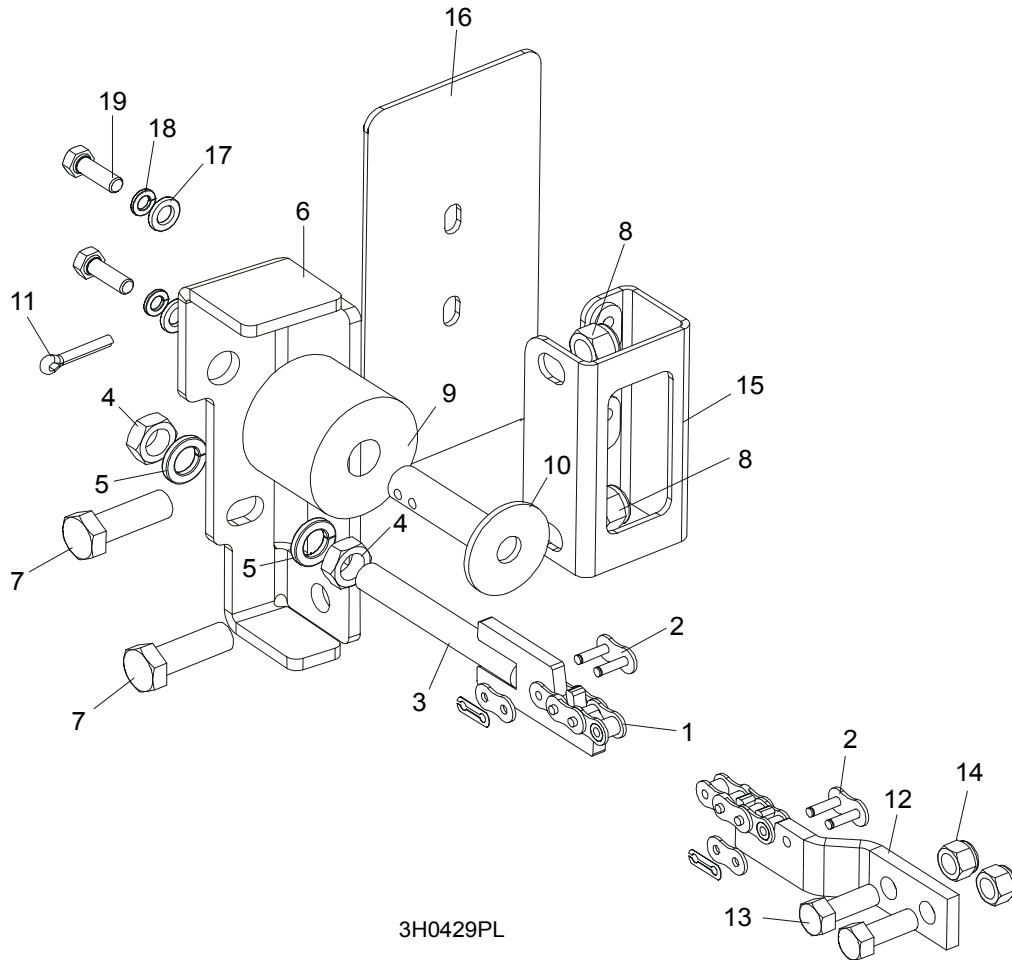

REF	DESCRIPTION (◆ Indicates Parts Available In Assemblies Only)	PART #	QTY.
	CHAIN KIT, LT40 S FEED	K10408	1
	CHAIN KIT, LT40 M FEED	K10410	1
1	Chain, #40 X 215" LT40S Feed	014744	1
	Chain, #40 X 267.5" LT40M Feed	014475	1
2	Link, #40 Master	P04200	2
3	Tensioner Weldment, Power Feed Chain	086818-1	1
4	Nut, M12-5 Hex Jam	F81034-4	2
5	Washer, 12.2 Split Lock	F81056-2	2
6	BRACKET, FEED CHAIN REAR MOUNT	087628-1	1
7	BOLT, M12 X 40 8.8 HEX HEAD GRADE 5	F81004-4	2
8	NUT, M12-8 HEX NYLON LOCK	F81034-2	2
	STOP KIT, RUBBER CARRIAGE	K09630	2
9	Stop, Rubber Carriage	P12165	1
10	Pin, Rubber Carriage Stop	W09293	1
11	Pin, 3/16" X 1" Cotter	F05012-21	1
12	BRACKET, FRONT FEED CHAIN MOUNT	015008	1

13	BOLT, 3/8-16 X 1" HEX HEAD	F81003-31	2	
14	NUT, 3/8-16 HEX NYLON LOCK	F81033-1	2	
15	BRACKET WELDMENT, REAR MAIN TUBE COVER MOUNT	087105-1	1	
16	COVER, REAR MAIN TUBE	015023	1	
17	WASHER, 8.4 FLAT	F81054-1	2	
18	WASHER, 8.2 SPLIT LOCK	F81054-4	2	
19	BOLT, M8x25-8.8 HEX HEAD	F81002-5	2	

7.4 Lower Track Rollers

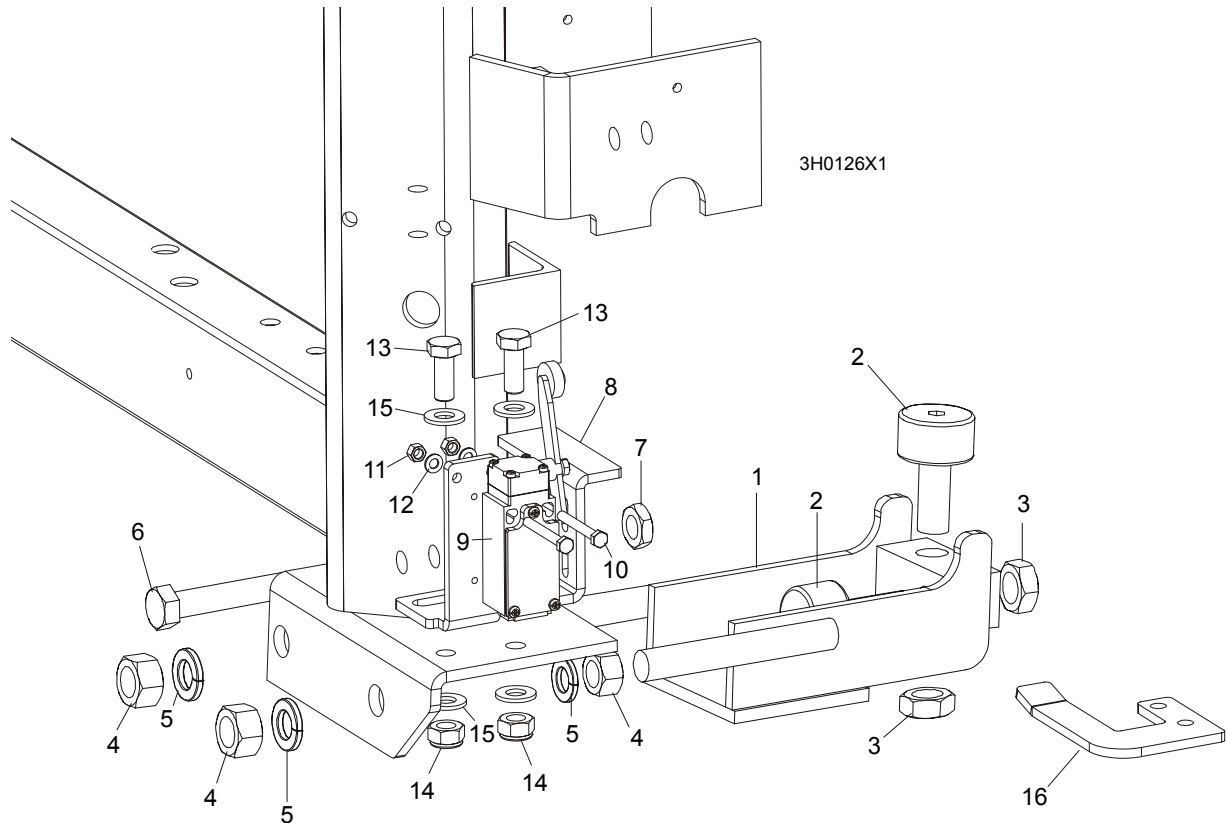

REF	DESCRIPTION (◆ Indicates Parts Available In Assemblies Only)	PART #	QTY.	
	ROLLER ASSEMBLY, LOWER TRACK	012995	2	
1	Bracket, Lower Track Roller Mounting	012982	1	◆
2	Roller, Track Cam Bearing (McGill)	012797	2	
3	Nut, 5/8-18 Hex Jam	F05010-11	2	
4	Nut, 5/8-11 Hex	F05010-5	4	
5	Washer, 16.3 Split Lock	F81058-2	4	
6	BOLT, M12 X 55-8.8 HEX HEAD FULL THREAD	F81004-12	2	
7	NUT, M12-8-B HEX JAM	F81034-1	2	
8	BRACKET, POWER SUPPLY STRIP AND LIMIT SWITCH	086380-1	1	
9	SWITCH, GLCB01A2B LIMIT	086469	1	
10	BOLT, M5 X 40 8.8 HEX HEAD	F810000-11	2	
11	NUT, M5-8	F81030-1	2	
12	WASHER, 5.3 FLAT	F81052-1	2	
13	BOLT, M10 X 25 8.8	F81003-11	2	
14	NUT, M10 NYLON	F81033-1	2	
15	WASHER, 10.5 FLAT	F81055-1	2	
16	BRACKET, LIMIT SWITCH	086473-1	1	

SECTION 8 BED FRAME ASSEMBLY

8.1 Bed Rail Assembly, Front And Rear

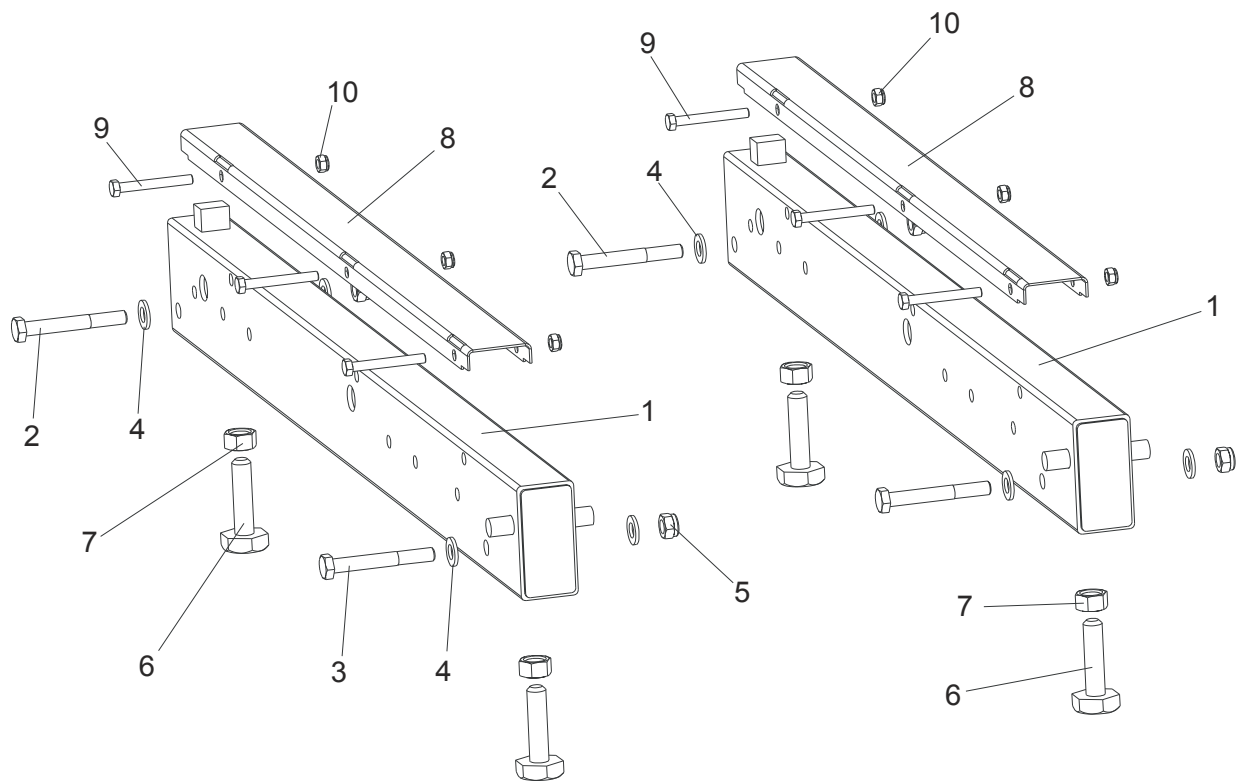

REF	DESCRIPTION (◆ Indicates Parts Available In Assemblies Only)	PART #	QTY.
1	BED RAIL ASSEMBLY, REAR PAINTED	091555	2
2	Bolt, M12 x 90-8.8 Hex Head	F81004-2	2
3	Bolt, M12 x 95-8.8 Hex Head	F81004-29	2
4	Washer, 13 SAE Flat	F81056-1	8
5	Nut, M12-8 Hex Nylon Lock	F81034-2	4
6	Bolt, M16, Bed Rail Adjustment	086809	4
7	Nut, M16-5-B Zinc Hex Head	F81036-5	4
8	COVER, STAINLESS STEEL BED RAIL	S09944	2
9	BOLT, M8X65-5,8 ZINC HEX HEAD	F81002-3	6
10	NUT, M8-8-B-ZINC HEX NYLON LOCK	F81032-2	6

8

Bed Frame Assembly Bed Rail Assembly, Front Middle

8.2 Bed Rail Assembly, Front Middle

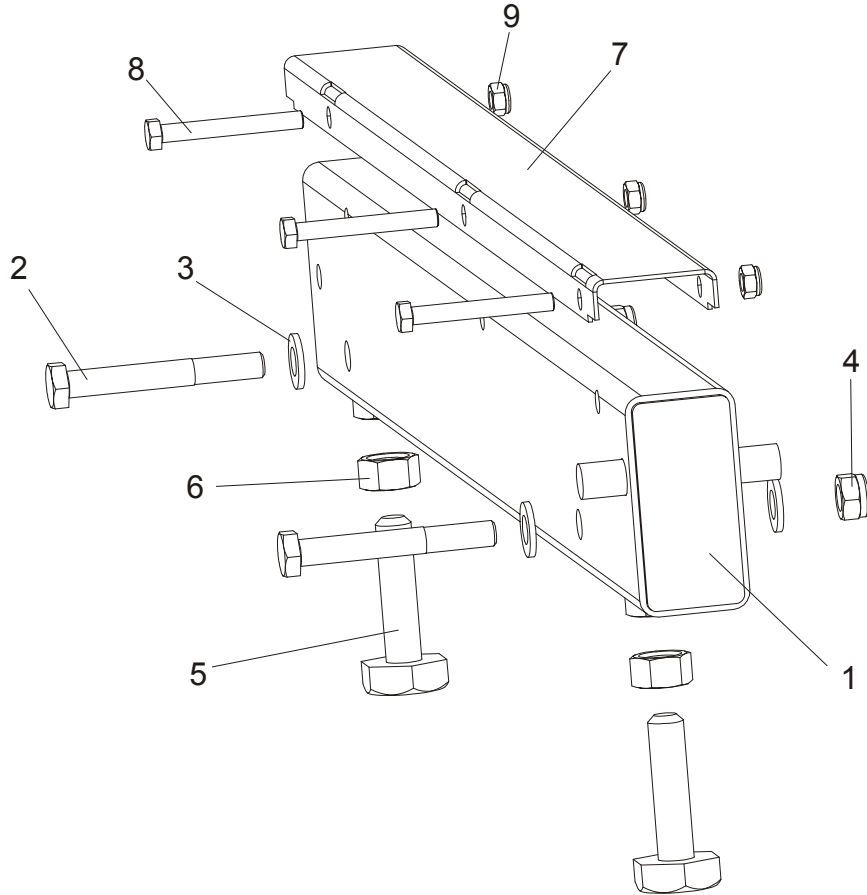

REF	DESCRIPTION (◆ Indicates Parts Available In Assemblies Only)	PART #	QTY.	
1	BED RAIL ASSEMBLY, FRONT MIDDLE	091556	1	
2	Bolt, M12 x 90-8.8 Hex Head	F81004-2	2	
3	Washer, 13 SAE Flat	F81056-1	4	
4	Nut, M12-8 hex Nylon Lock	F81034-2	2	
5	Bolt, M16, Bed Rail Adjustment	086809	2	
6	Nut, M16-5-B Zinc Hex Head	F81036-5	2	
7	COVER, STAINLESS STEEL BED RAIL	S09944	2	
8	BOLT, M8X65-5,8 ZINC HEX HEAD	F81002-3	3	
9	NUT, M8-8-B-ZINC HEX NYLON LOCK	F81032-2	3	

8.3 Bed Rail Assembly, Rear Middle

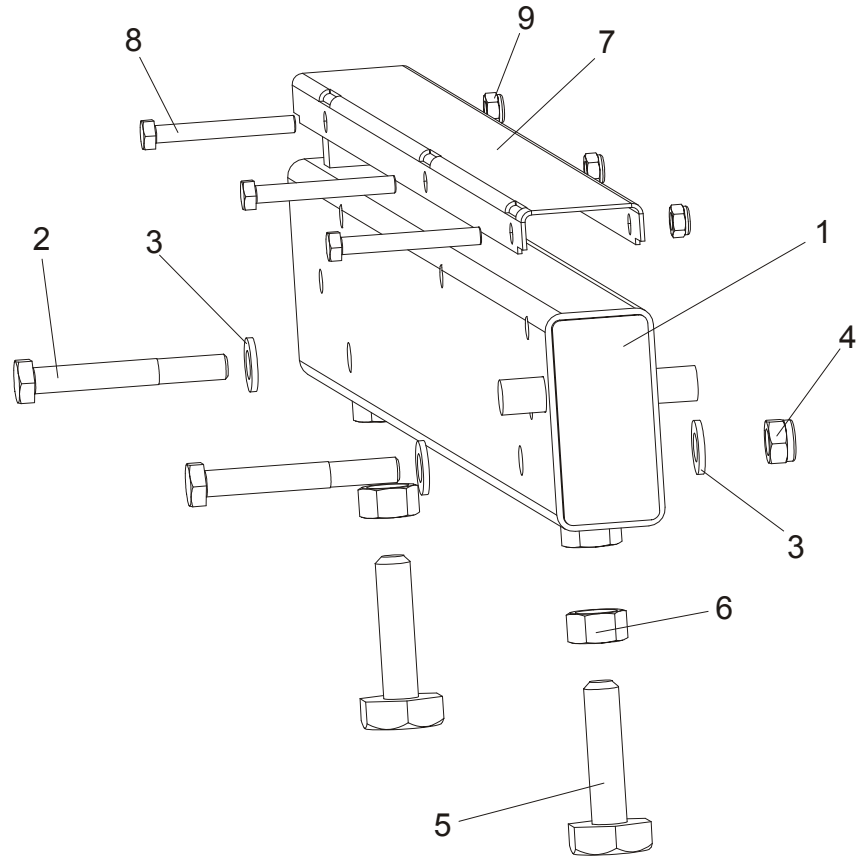

REF	DESCRIPTION (◆ Indicates Parts Available In Assemblies Only)	PART #	QTY.
1	BED RAIL ASSEMBLY, REAR MIDDLE PAINTED	091557	1
2	Bolt, M12 x 90-8.8 Hex Head	F81004-2	2
3	Washer, 13 SAE Flat	F81056-1	4
4	Nut, M12-8 hex Nylon Lock	F81034-2	2
5	Bolt, M16, Bed Rail Adjustment	086809	2
6	Nut, M16-5-B Zinc Hex Head	F81036-5	2
7	COVER, STAINLESS STEEL BED RAIL	S09944	2
8	BOLT, M8X65-5,8 ZINC HEX HEAD	F81002-3	3
9	NUT, M8-8-B-ZINC HEX NYLON LOCK	F81032-2	3

8 Bed Frame Assembly

Leg, Stationary

8.4 Leg, Stationary

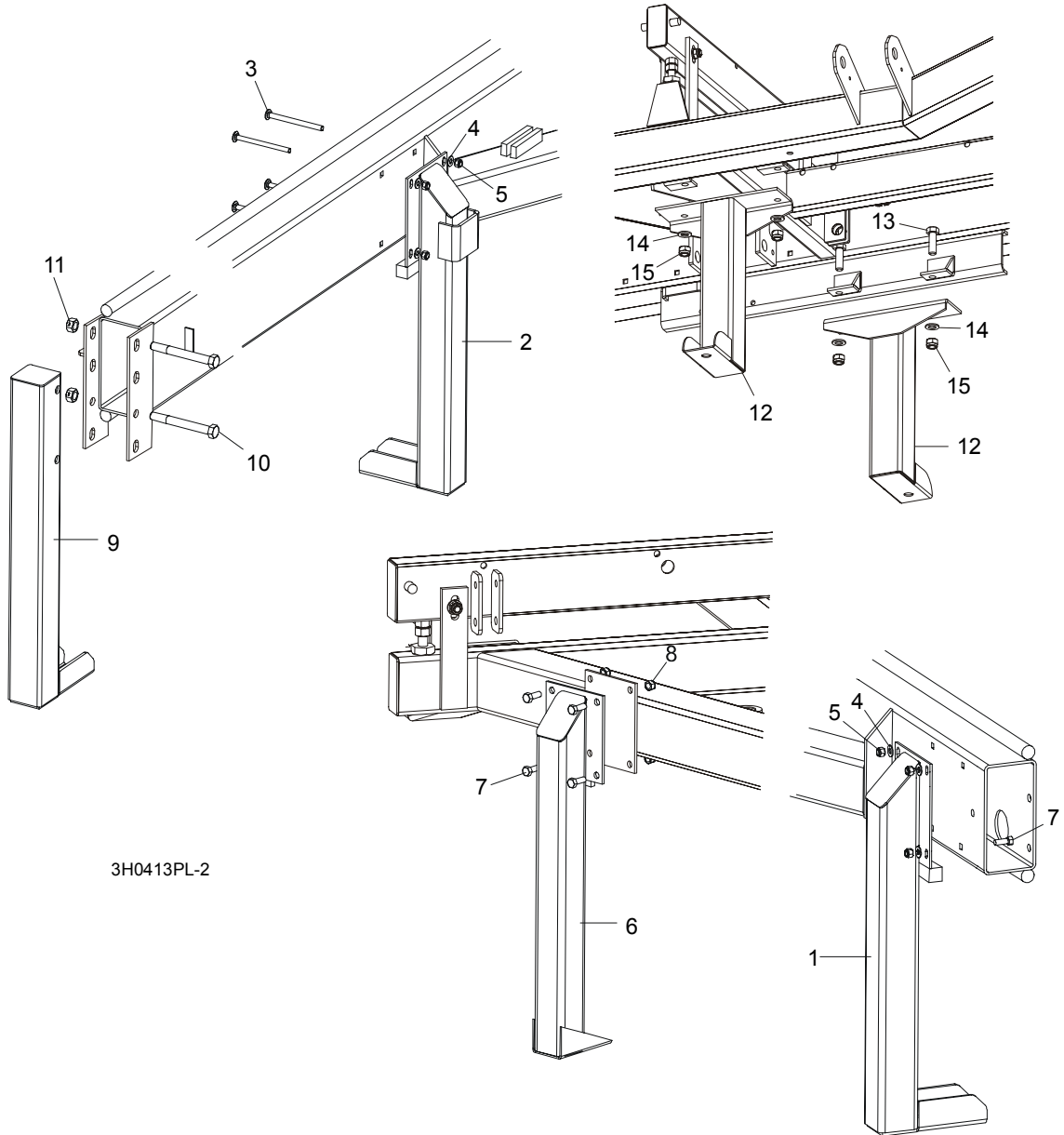

3H0413PL-2

REF	DESCRIPTION (◆ Indicates Parts Available In Assemblies Only)	PART #	QTY.
1	LEG, LONG RIGHT STATIONARY (1 REQ'D FOR LT40S; 3 REQ'D FOR LT40)	087451-1	1/3
2	LEG, LONG STATIONARY W/BOARD RETURN TABLE BRACKET	087449-1	1
3	BOLT, M10 X 120-8.8 CARRIAGE HEAD	F81003-33	8/12
4	WASHER, 10.5 FLAT	F81055-1	8/16
5	NUT, M10-8-B HEX NYLON LOCK	F81033-1	8/16
6	LEG, SHORT LEFT STATIONARY	087450-1	2
7	BOLT, M10 X 25-8.8 HEX HEAD	F81003-11	12
8	NUT, M10-8-B HEX NYLON LOCK	F81033-1	12
9	LEG, FRONT STATIONARY	087452-1	1

10	BOLT, M16 X 140-8.8 HEX HEAD GRADE 5	F81006-4	2	
11	NUT, M16-8 HEX LOCK	F81036-2	2	
12	LEG, MIDDLE STATIONARY	087093-1	2	
13	BOLT, M16 X 50-8.8 HEX HEAD	F81006-7	4	
14	WASHER, 17 FLAT	F81058-1	4	
15	NUT, M16 NYLON LOCK	F81036-2	4	

8 Bed Frame Assembly

Board Return Table Assembly

8.5 Board Return Table Assembly

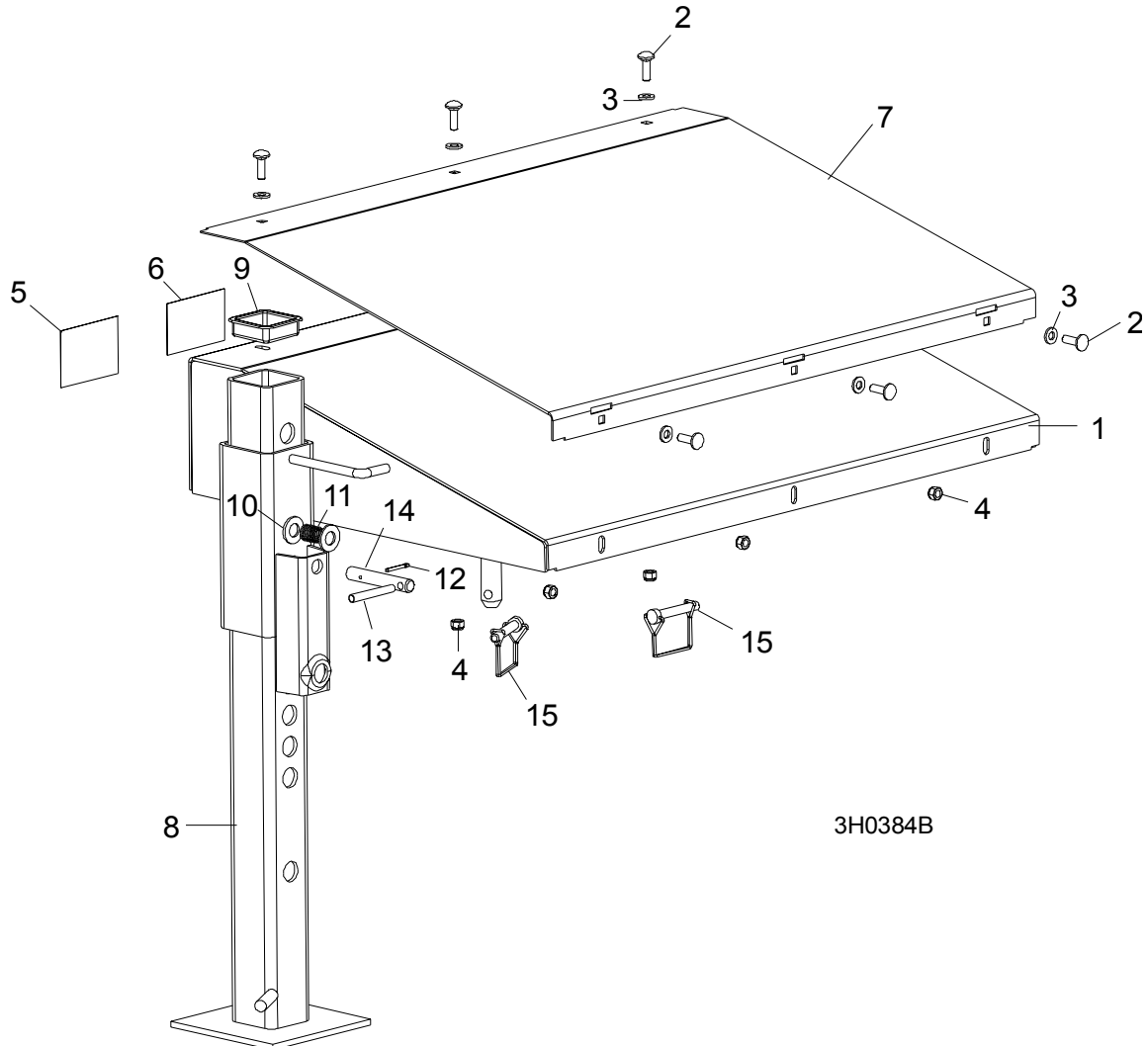

3H0384B

	DESCRIPTION (◆ Indicates Parts Available In Assemblies Only)	PART #	QTY.	
	TABLE ASSEMBLY, BOARD RETURN	091397	1	
1	Table Weldment, Board Return	091225-1	1	◆
2	Bolt, 5/16-18 x 1" Carriage Head	F81002-1	6	
3	Washer, 5/16" SAE Flat	F81032-2	6	
4	Nut, 5/16-18 Nylon Lock	F81054-1	6	
5	Decal, Board Return Danger	015365	1	
6	Decal, Board Return Table Warning	016077	1	
7	Plate, Return Table Stainless Steel	091396	1	
8	Leg Weldment, Painted Outrigger	089691-1	1	
9	Cap, Outrigger Leg	089710	1	
10	Washer, M20 Flat Zinc	F81059-2	2	
11	Spring, 21x38x2 Diameter Stainless Steel Compression	087040	1	
12	Pin, 4x25 Cotter	F81043-2	1	

13	Pin, 8x65 Roll	F81046-1	1	
14	Pin, Outrigger Pull	087012-1	1	
15	Pin, 3/8 X 2 1/4" Square Wire Lock	014151	2	

8 Bed Frame Assembly

Pivot Bed Rail Assembly

8.6 Pivot Bed Rail Assembly

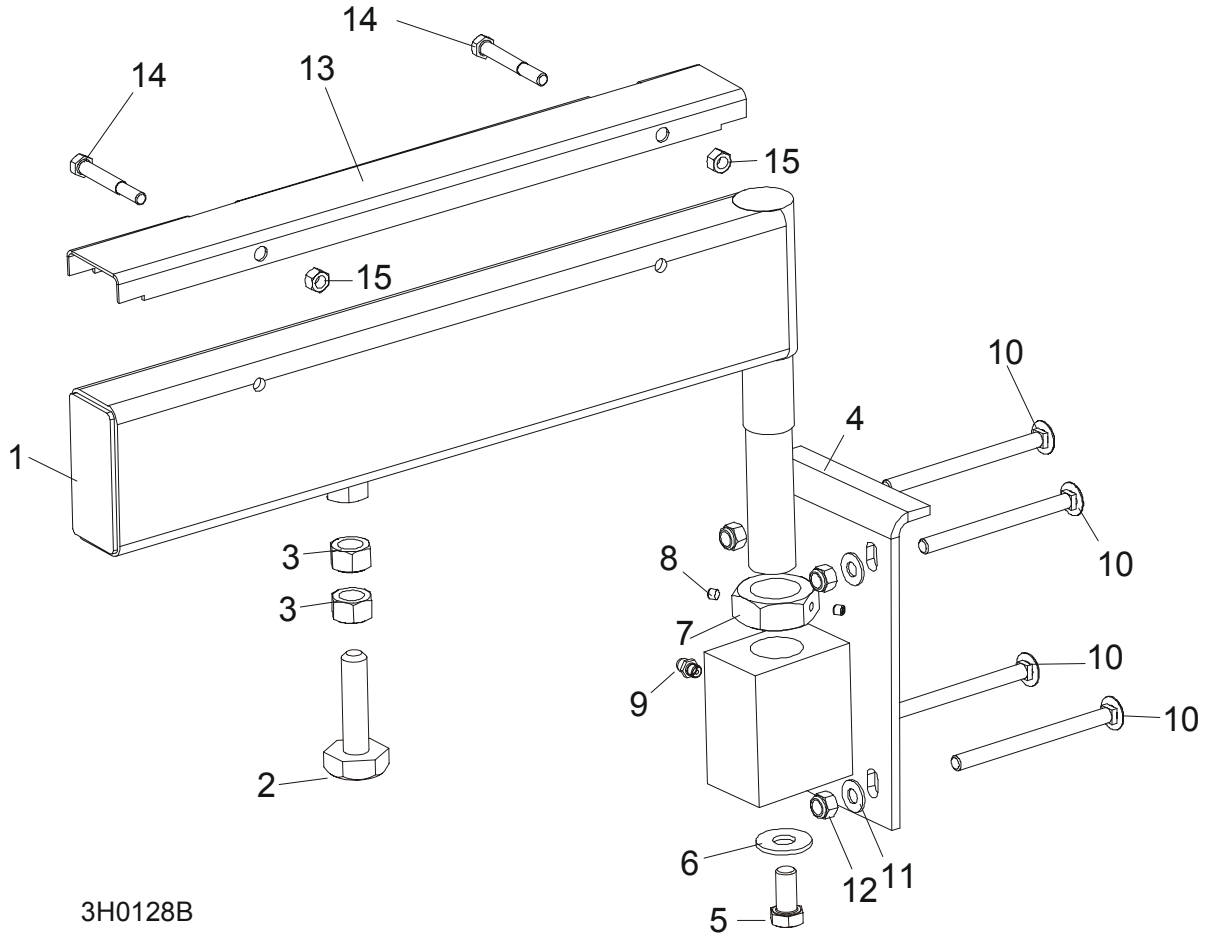

3H0128B

REF	DESCRIPTION (◆ Indicates Parts Available In Assemblies Only)	PART #	QTY.
	PIVOT BED RAIL ASSEMBLY (LT40S)	087829	2
	PIVOT BED RAIL ASSEMBLY (LT40M)	087855	2
1	Pivot Bed Rail Weldment (LT40S)	087852	1
	Pivot Bed Rail Weldment (LT40M)	087848	1
	Bolt Assembly, Bed Rail Adjustment		1
2	Bolt, Bed Rail Adjustment	086809	1
3	Nut, 5/8-11 Hex	F81036-1	2
4	Bracket, Pivot Rail Mounting	087841-1	1
5	Bolt, 1/2-13 x 1" Hex Head Grade 2	F81004-31	1
6	Washer, 15 Flat	F05011-52	1
7	Nut, Pivot Rail Adjustment (LT40S) Nut, Pivot Rail Adjustment (LT40M)	F81036-1 F81039-2	1
8	Screw, 1/4-28 x 1/4" Brass Tip Set	F05005-42	2
9	Fitting, 3/16" Grease	086280	1
10	BOLT, 3M10 X 120-8.8 CARRIAGE HEAD	F81003-33	8
11	WASHER,10.5 FLAT	F81055-1	8

12	NUT, M16-8 NYLON LOCK	F81036-2	8	
	COVER KIT, PIVOT RAIL STAINLESS STEEL (LT40S)	015926	2	
	COVER KIT, PIVOT RAIL STAINLESS STEEL (LT40)	N/A	2	
13	Cover, Stainless Steel Pivot Bed Rail (LT40S)	012994	1	
	Cover, Stainless Steel Pivot Bed Rail (LT40M)	S13012	1	
14	Bolt, M8x65-5,8 Zinc Hex Head	F81002-3	4	
15	Nut, M8-8-B-Zinc Hex Nylon Lock	F81032-2	4	
	WRENCH, BED RAIL ADJUSTMENT (See Section 8.3)	015970	1	

8 Bed Frame Assembly

Log Side Support Assembly

8.7 Log Side Support Assembly

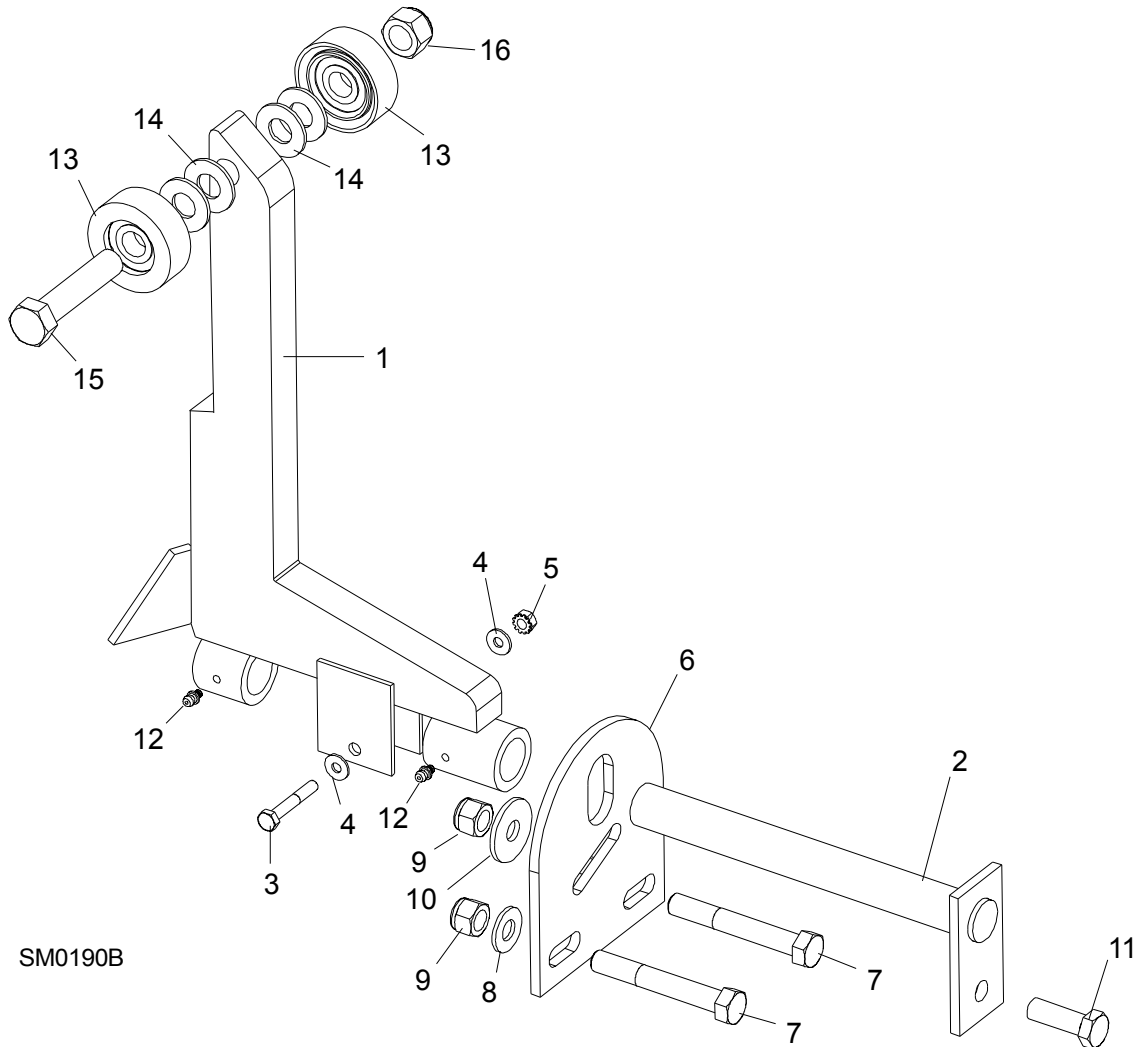

REF	DESCRIPTION (◆ Indicates Parts Available In Assemblies Only)	PART #	QTY.
	SUPPORT, LOG SIDE	092686	1
1	MOUNTING KIT, LOG SIDE SUPPORT	085538-1	3
2	Pin, Log Side Support Pivot	091549-1	1
3	Bolt, M8x45 - 8.8 Hex Head Grade 5	F81002-14	1
4	Washer, 8.4 Flat	F81054-1	2
5	Nut, M8-8-B Self Locking	F81032-2	1
6	Plate, Log Side Support End	091591-1	1
7	Bolt, M12 x 75-8.8 Hex Head	F81004-21	2
8	Washer, 13 Flat	F81056-1	2
9	Nut, M12-8 Hex Nylon Lock	F81034-2	3
10	Washer, 15 Flat Special Zinc-Plated	F81057-3	1
11	Bolt, M12 x 35-8.8 Hex Head	F81004-24	1

12	FITTING, 3/16" GREASE	P04107	2	
13	Roller Assembly, Side Support	015014-1	2	
14	Washer, 17 Flat	F81058-1	2	
15	Bolt, M16x65-8.8-B Hex Head Grade 5	F81006-1	1	
16	Nut, M16-8 Nylon Lock	F81036-2	1	
	Instruction Sheet, Side Support Roller	015109-526	1	

8 **Bed Frame Assembly**
Tie Down Chain Assembly

8.8 Tie Down Chain Assembly

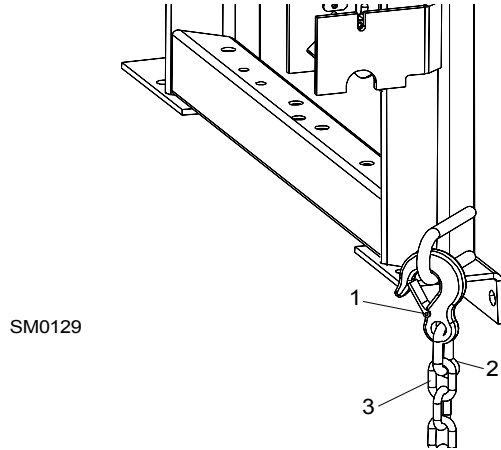

REF	DESCRIPTION (◆ Indicates Parts Available In Assemblies Only)	PART #	QTY.	
	CHAIN ASSEMBLY, TIE DOWN	A04376	1	
1	Hook, 5/8" Safety Chain	P12075	1	◆
2	Cold Shut, 3/8" Plain	P04772-2	1	◆
3	Chain, N-10 x 35 Unplated	R80558	.28 m	◆

8.9 Saw Head Rest Pin Assembly

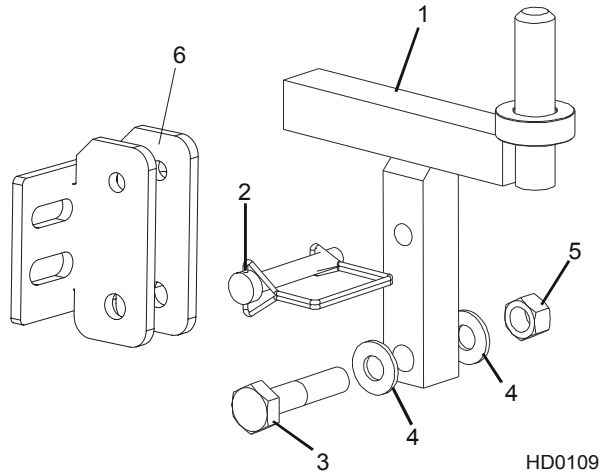

REF	DESCRIPTION (◆ Indicates Parts Available In Assemblies Only)	PART #	QTY.
1	PIN, SAW HEAD REST	085949	1
2	PIN, 3/8" X 2 1/4" SNAP RETAINER	014151	1
3	BOLT, M12 X 60-8.8 HEX HEAD GRADE 5	F81004-5	1
4	WASHER, 13 SAE FLAT	F81056-1	2
5	NUT, M12-8 HEX LOCK	F81034-2	1
6	BRECKET, SAW HEAD REST PIN MOUNT	092765-1	1

8 Bed Frame Assembly

Bed Frame Decals

8.10 Bed Frame Decals

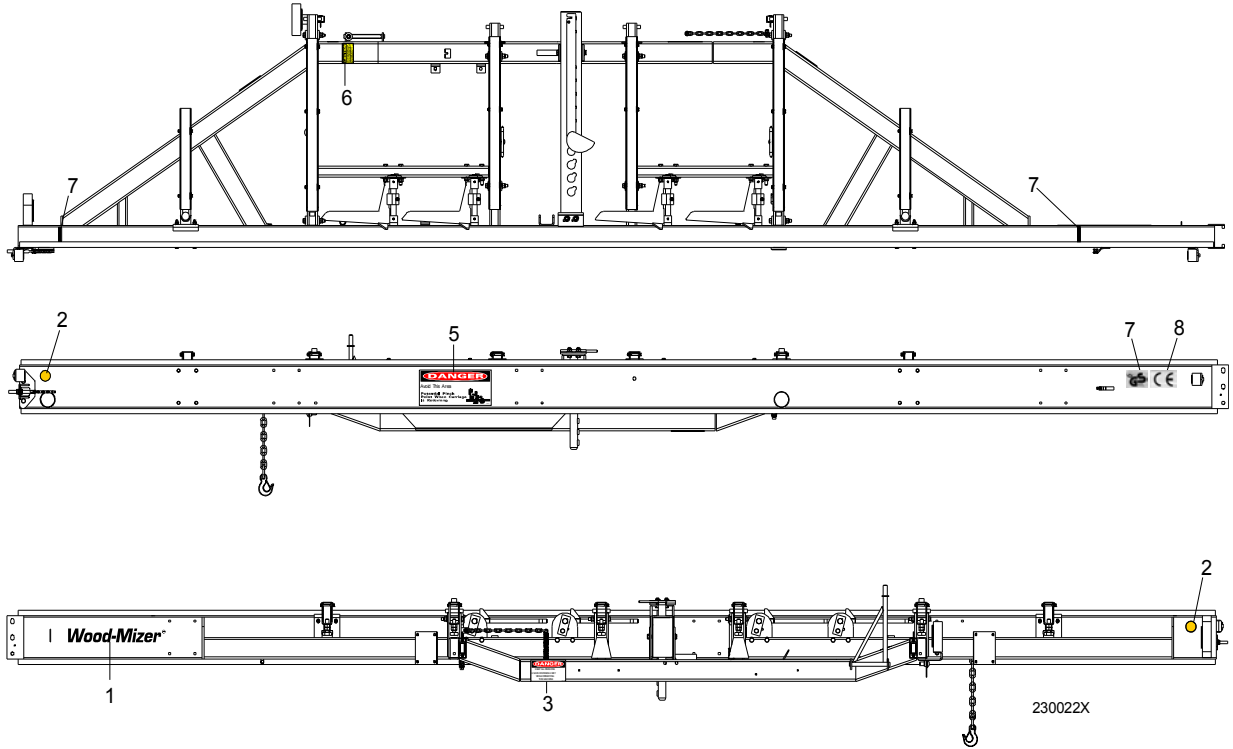

REF	DESCRIPTION (◆ Indicates Parts Available In Assemblies Only)	PART #	QTY.
1	DECAL, WOOD-MIZER SUPER LOGO	014751	1
2	DECAL, AMBER REFLECTIVE 2" ROUND	P07453	2
3	DECAL, KEEP AWAY DANGER	S09851	1
4	DECAL, PINCH POINT DANGER	P10287	1
5	DECAL, SAW HEAD REST CAUTION	S12581	1
6	DECAL, LOG LIMIT STRIPE	S12051	2
7	DECAL, GS SAFETY CERTIFICATION, SMALL	P85072	1
8	DECAL, CE CERTIFIED SAWMILL, SMALL	P85070	1

SECTION 9 LOG CLAMP, TURNER, LOADER & TOE BOARDS

9.1 Manual Log Clamp

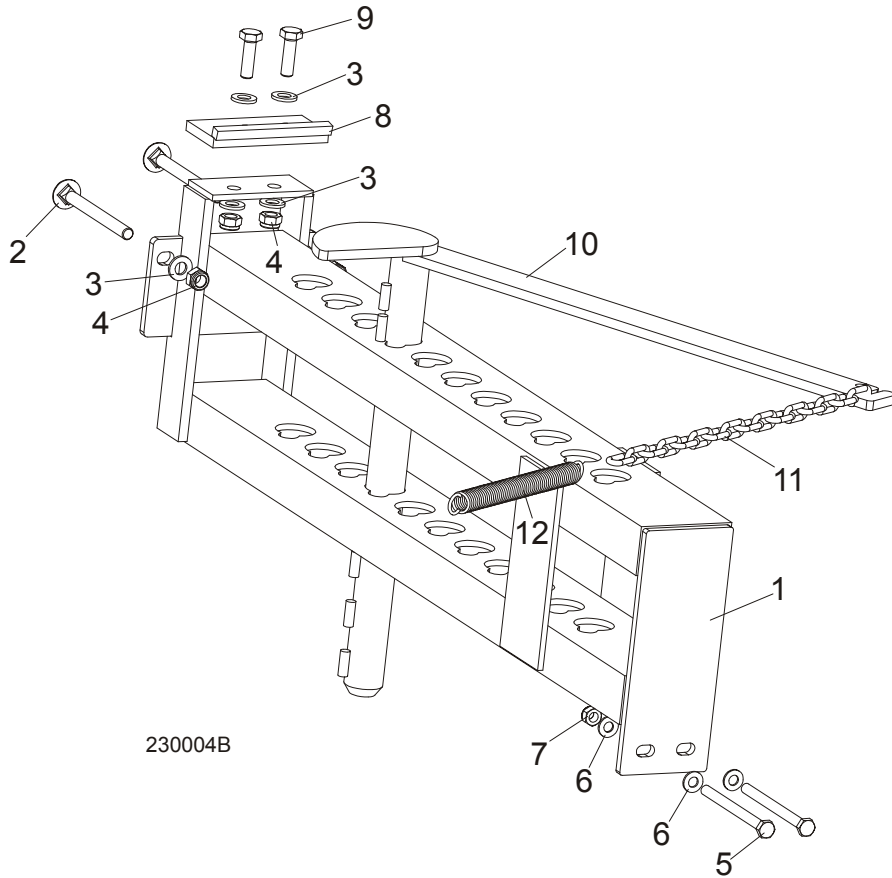

REF	DESCRIPTION (◆ Indicates Parts Available In Assemblies Only)	PART #	QTY.	
	MANUAL LOG CLAMP	092683	1	
1	Bracket, Log Clamp	092677-1	1	
2	Bolt, M12x130-8.8 Hex Head, Full Thrd, Zinc	F81004-26	2	
3	Washer, 13 Flat	F81056-1	6	
4	Nut, M12-8 Hex Nylon Lock	F81034-2	4	
5	Bolt, M10x125-8.8 Hex Head, Zinc	F81003-18	2	
6	Washer, Flat, M10, Zinc	F81055-1	4	
7	Nut, M10, Nylon Hex Zinc Lock	F81033-1	2	
8	Plate, Log Clamp Stop	086980-1	1	
9	Bolt, M12 x 40-8.8 Hex Head	F81004-4	2	
10	Clamp, Log	W09412	1	
11	Chain, Log Clamp	M04311	1	
12	Spring, FI 2,8 X FI 22,2 X 183	091864	1	

9.2 Log Clamp Assembly

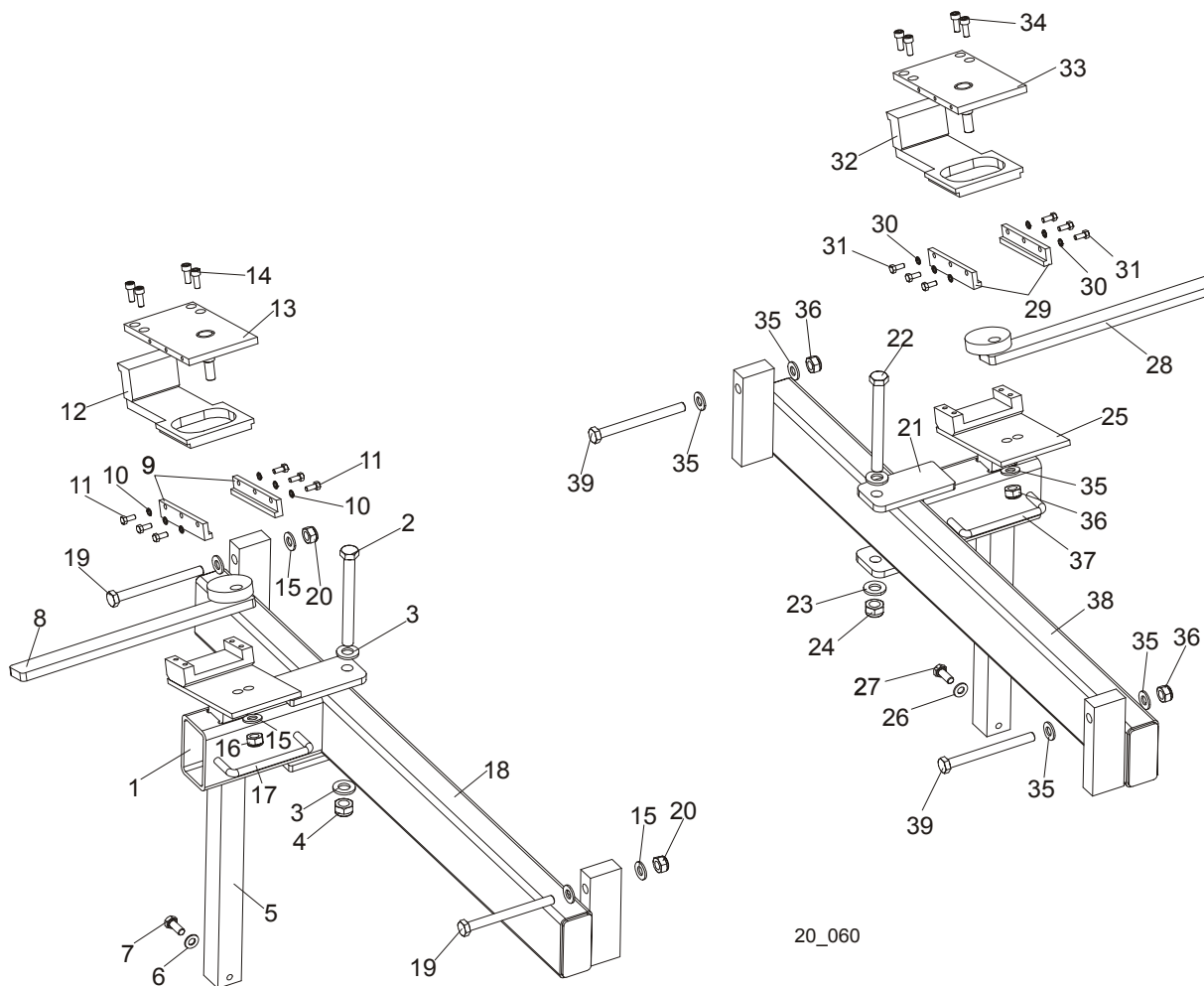

20_060

REF	DESCRIPTION (◆ Indicates Parts Available In Assemblies Only)	PART #	QTY.
	LOG CLAMP ASSEMBLY, LEFT (NON-HYDRAULIC)	089631 ◆	1
1	Arm Weldment, Log Clamp Zinc-plated	089624-1	1
2	Bolt, M12x120 8.8 Hex Head Zinc	F81004-38	1
3	Washer, 13 Zinc Flat	F81056-1	2
4	Nut, M12-8 Hex Nylon Zinc Lock	F81034-2	1
5	Mount Weldment, Log Clamp Zinc-plated	090174-1	1
6	Washer, 8.4 Zinc Flat	F81054-1	4
7	Bolt, M8x20-8.8-B Hex Head Full Thread Zinc	F81002-4	2
8	Lever, Log Clamp Zinc-plated	089611-1	1
9	Plate, Log Clamp Side Zinc-plated	089615-1	2
10	Washer, 5.1 Split Lock Zinc	F81052-2	6
11	Bolt, M5x12-5.8 Hex Head Full Thread Zinc	F81000-5	6

Log Clamp, Turner, Loader & Toe Boards

Log Clamp Assembly

9

12	Plate, Clamping Zinc-plated	090202-1	1	
13	Plate, Log Clamp Upper Zinc-plated	089614-1	1	
14	Screw, M6x16-8.8 Hex Socket Set Cap Zinc	F81001-21	4	
15	Washer, 10.5 Zinc Flat	F81055-1	5	
16	Nut, M8-8-B Hex Nylon Zinc Lock	F81032-2	1	
17	Handle, 4" w/Bolts	P08065	1	
18	Bar Weldment, Log Clamp Guide Ptd	089628-1	1	
19	Bolt, M10x110 8.8 Hex Head Zinc	F81003-43	2	
20	Nut, M10-8-B Hex Nylon Zinc Lock	F81033-1	2	
	LOG CLAMP ASSEMBLY, RIGHT (NON-HYDRAULIC)	090349	1	
21	Arm Weldment, Log Clamp Zinc-plated	089624-1	1	
22	Bolt, M12x120 8.8 Hex Head Zinc	F81004-38	1	
23	Washer, 13 Zinc Flat	F81056-1	2	
24	Nut, M12-8 Hex Nylon Zinc Lock	F81034-2	1	
25	Mount Weldment, Log Clamp Zinc-plated	090174-1	1	
26	Washer, 8.4 Zinc Flat	F81054-1	2	
27	Bolt, M8x20-8.8-B Hex Head Full Thread Zinc	F81002-4	2	
28	Lever, Log Clamp Zinc-plated	090348-1	1	
29	Plate, Log Clamp Side Zinc-plated	089615-1	2	
30	Washer, 5.1 Split Lock Zinc	F81052-2	6	
31	Bolt, M5x12-5.8 Hex Head Full Thread Zinc	F81000-5	6	
32	Plate, Clamping Zinc-plated	090202-1	1	
33	Plate, Log Clamp Upper Zinc-plated	090347-1	1	
34	Screw, M6x16-8.8 Hex Socket Head Cap Zinc	F81001-21	4	
35	Washer, 10.5 Zinc Flat	F81055-1	5	
36	Nut, M10-8-B Hex Nylon Zinc Lock	F81033-1	3	
37	Handle, 4" w/Bolts	P08065	1	
38	Bar Weldment, Log Clamp Guide Ptd	089628-1	1	
39	Bolt, M10x110 8.8 Hex Head Zinc	F81003-43	2	

¹ The number of clamps depends on the frame length.

9.3 Manual Log Turner

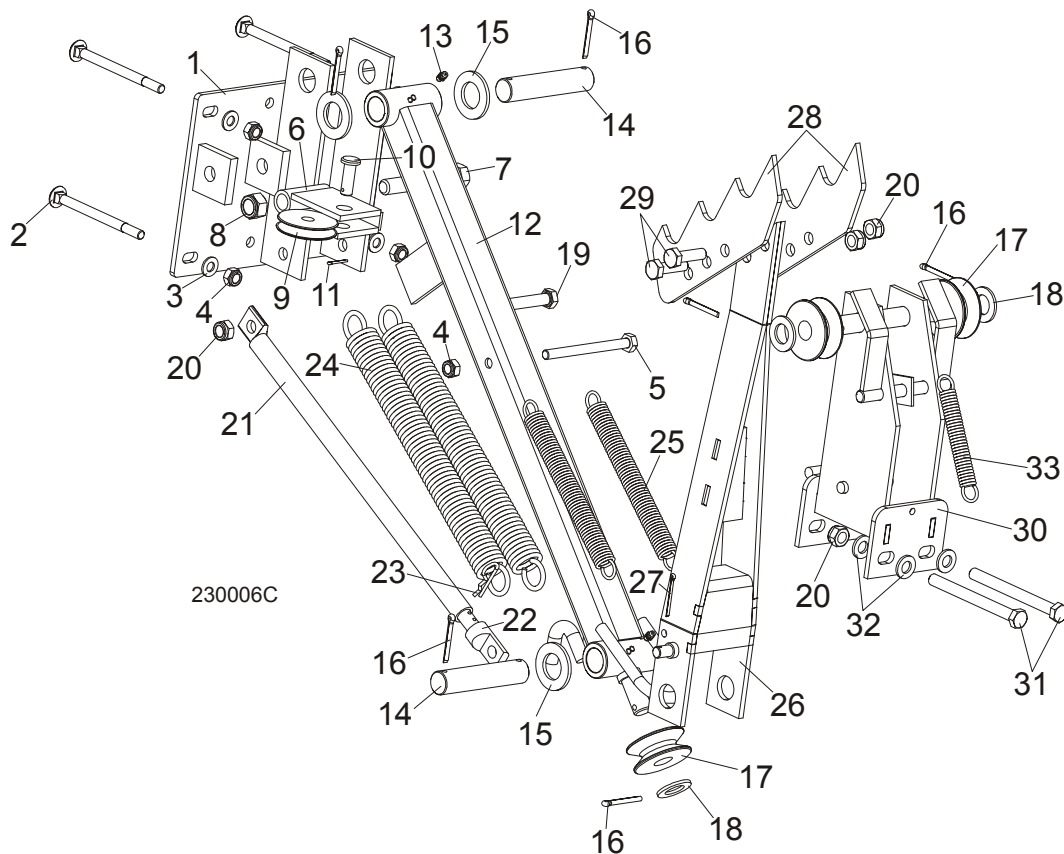

REF	DESCRIPTION (◆ Indicates Parts Available In Assemblies Only)	PART #	QTY.
	MANUAL LOG TURNER OPTION (S/M TYPE FRAME)	091291	1
	MANUAL LOG TURNER OPTION (L TYPE FRAME)	091562	1
1	Handle, Manual Log Turner (S/M type frame)	091269-1	1
	Handle, Manual Log Turner (L type frame)	090271-1	1
2	Bolt, M10X120mm, Hex Head, Full Thrd, Zinc	F81003-33	4
3	Washer, Flat, M10, Zinc	F81055-1	4
4	Nut, M10, Nylon Hex Zinc Lock	F81033-1	5
5	Bolt, M10x115mm, Hex Head, Gr 5.8 Zinc	F81003-19	1
6	Handle, Manual Turner Cable Pulley	091295-1	1
7	Bolt, M16X100mm, Hex Head Full Thrd, Zinc	F81006-2	1
8	Nut, M16, Hex, Nylon Zinc Lock	F81036-2	1
9	Pulley, Manual Turner Arm Cable	091273-1	1
10	Pin, 12x35 PN-90/M-83002 Zinc, ODM.B	F81049-1	1
11	Pin, 2,5x20 Cotter	F81043-1	1
12	Arm, Lower Manual Turner	091256-1	1
13	Fitting, M6 Grease	086280	2

Log Clamp, Turner, Loader & Toe Boards

Manual Log Turner

9

14	Pin, Manual Turner Arm Pivot	091275-1	2	
15	Washer 28 Fe/Zn5	F81061-1	4	
16	Pin, 5x40 Cotter	F81043-31	7	
17	Pulley, Manual Turner Cable	091280-1	3	
18	Washer, M20, Flat Unplated	F81059-1	5	
19	Bolt, M12X120mm, HH, Grade 5.8, Zinc	F81004-38	1	
20	Nut, M12, Hexagon, Nylon, Zinc, Lock	F81034-2	5	
21	Tube, Manual Turner Stop	091537-1	1	
22	Rod, Manual Turner Stop	091540-1	1	
23	Pin, 1/8x1 13/16 Safety	P05059	1	
24	Spring, FI 4,5X FI 35X303	091863	2	◆
25	Spring, FI 2,8 X FI 22,2 X 183	091864	2	
26	Arm, Upper Manual Turner	091263-1	1	
27	Pin, 4x25 Cotter	F81043-2	1	
28	Claw, Log Turner	088082-1	2	
29	Bolt, M12X40mm, Hex Head, Gr 8.8 Zinc	F81004-4	2	
30	Bracket, Manual Turner Cable Pulley	091281-1	1	
31	Bolt, M12x130-8.8-Fe/Zn5 PN-M/82101	F81004-36	2	
32	Washer, M12 , Flat, Zinc	F81056-1	4	
33	Spring, FI 1,9 X FI 14,2 X 104	091865	1	

9.4 Manual Toe Board

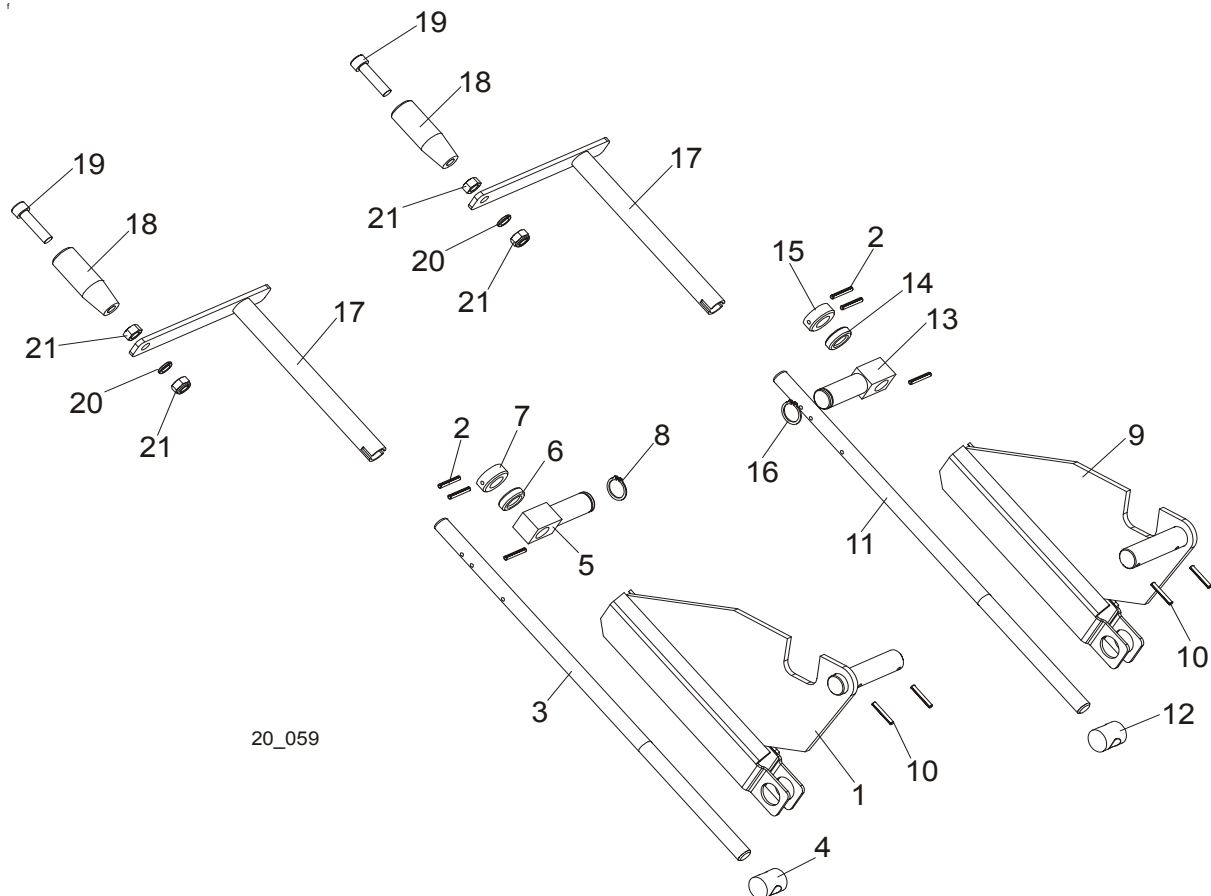

REF	DESCRIPTION (◆ Indicates Parts Available In Assemblies Only)	PART #	QTY.
	TOE BOARD KIT, MANUAL FRONT	090026	1
1	Plate Weldment, Manual Toe Board Front	090025-1	1
2	Pin, Zinc Roll PN-EN ISO 8752-5X35-N-C	F81044-9	3
3	Shaft, Manual Toe Board	090344-1	1
4	Nut, Special Threaded	090017	1
5	Pivot, Manual Toe Board Shaft	090013-1	1
6	Bearing, 5/8" Thrust	P04214	1
7	Collar, 16	F81039-6	1
8	Ring, Z 22 Outside Retaining	F81090-24	1
10	Pin, 4x30 Zinc Roll	F81044-7	2
	TOE BOARD KIT, MANUAL REAR	090024 ¹	1
2	Pin, 4x30 Zinc Roll PN-EN ISO 8752-5X35-N-C	F81044-9	3
9	Plate Weldment, Manual Toe Board Rear	090023-1	1
10	Pin, 4x30 Zinc Roll	F81044-7	2
11	Shaft, Manual Toe Board	090016-1	1

12	Nut, Special Threaded	090017	1	
13	Pivot, Manual Toe Board Shaft	090013-1	1	
14	Bearing, 5/8" Thrust	P04214	1	
15	Collar, 16	F81039-6	1	
16	Ring, Z 22 Outside Retaining	F81090-24	1	
	Crank Assembly, Manual Toe Board	A09432	2	
17	Crank, Manual Toe Board	W09431	1	
18	Handle, Crank	S08291-W	1	
19	Screw, 3/8-16 x 2 1/2" Socket Head Cap	F05007-24	1	
20	Washer, 3/8" Split Lock	F81055-2	1	
21	Nut, 3/8-16 Hex	F05010-1	2	

¹ The number of kits depends on the frame length.

9.5 Log Loading Ramps

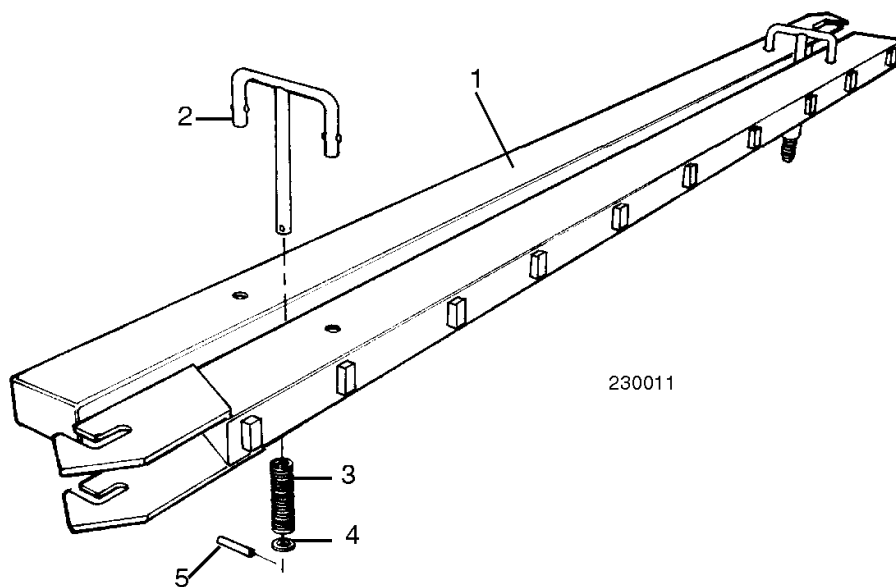

REF	DESCRIPTION (◆ Indicates Parts Available In Assemblies Only)	PART #	QTY.	
	RAMP KIT, LOG LOADING WITH RETAINERS	K09466	1	
1	Ramp, Log Loading	W09014	2	
	Retainer Kit, Log Ramp	K09810	2	
2	Retainer, Log Ramp	W09413	1	◆
3	Spring, Log Ram Retainer	P09335	1	
4	Washer, 5/8" I.D. x .100" Thick Nylon	F05011-19	1	
5	Pin, 3/16" x 1" Roll	F05012-11	1	