

Wood-Mizer®

Parts Manual

LT40 Series MH

rev. F1.03



Safety is our #1 concern! Read and understand all safety information and instructions before operating, setting up or maintaining this machine.

Form #534

Table of Contents

Section-Page

SECTION 1	GENERAL INFORMATION	1-1
1.1	How To Use the Parts List.....	1-1
1.2	Sample Assembly	1-1
SECTION 2	BLADE GUIDE ROLLERS & ARM	2-1
2.1	Blade Guide Assembly, Idle Side (Standard).....	2-1
2.2	Blade Guide Assembly, Idle Side (Optional).....	2-3
2.3	Blade Guide Assembly, Drive Side (Optional).....	2-5
2.4	Blade Guide Mount Block (LT40 Wide)	2-7
2.5	Blade Guide Mount Block (LT40 Wide)	2-8
2.6	Idle Side Blade Guide Assembly, Optional (LMS).....	2-9
2.7	Blade Guide Assembly, Drive Side.....	2-11
2.8	Blade Guide Arm & Rollers	2-13
2.9	Blade Guide Arm Drive Assembly.....	2-14
2.10	Drive Assembly, Blade Guide Arm (LT40 Wide)	2-16
2.11	Drive Roller, Blade Guide Arm	2-18
2.12	Idler Roller, Blade Guide Arm	2-19
SECTION 3	BLADE WHEELS & TENSIONER	3-1
3.1	Blade Drive Assembly.....	3-1
3.2	Idle Blade Wheel Assembly	3-3
3.3	Blade Tensioner Guide Arms (LT40 Wide)	3-4
3.4	Hydraulic Blade Tensioner Assembly.....	3-5
SECTION 4	SAW HEAD	4-1
4.1	Middle Throat Screw.....	4-1
4.2	Water Lube Solenoid Valve (not available in EC version)	4-1
4.3	Clutch Lever Assembly	4-2
4.4	Brake Assembly.....	4-4
4.5	Board Return Assembly	4-5
4.6	Water Lube Assembly	4-7
4.7	LT40DC Saw Head Decals	4-9
4.8	Blade Housing Covers	4-11
4.9	Drive Belt Covers	4-13
4.10	Sawdust Chute	4-14
4.11	Saw Head Pin	4-15
4.12	Saw Head Rest Bracket. Plate Mount.	4-16
4.13	LT20/40 Saw Head Rest Bracket	4-17
4.14	Saw Head Support Bracket (New M-type Frame, Mobile Sawmills)	4-18
4.15	Saw Head Rest Assembly, LT40M - 2.2	4-19
4.16	LT40 Wide Saw Head Parts	4-20
4.17	Motor Mount Clamp	4-22

Table of Contents

Section-Page

4.18	Blade Guide Arm w/Drive	4-23	
SECTION 5 CONTROL & BATTERY BOXES			5-1
5.1	Control Assembly, LT40 Series DH	5-1	
5.2	Control Assembly (Gas/Diesel), Optional Equipment	5-4	
5.3	Control Box Bracket.....	5-6	
5.4	Drum Switches	5-7	
5.5	Circuit Breakers	5-8	
5.6	Solenoid Assemblies	5-9	
5.7	Battery Box Assembly, LT40DC Series MH	5-10	
SECTION 6 UP/DOWN SYSTEM			6-1
6.1	Saw Head V-Brace Mount	6-1	
6.2	Blade Height Scale	6-2	
6.3	Up/Down Chain & Sprockets.....	6-4	
6.4	Up/Down Motor Assembly, LT40 Series	6-6	
6.5	Up/Down Drive Assembly, LT40 Series	6-7	
SECTION 7 POWER FEED & TRACK ROLLERS			7-1
7.1	Upper Track Rollers And Wipers.....	7-1	
7.2	Power Feed Assembly	7-2	
7.3	Feed Chain/Stop, LT40 Series	7-4	
7.4	Lower Track Rollers	7-6	
SECTION 8 BED FRAME ASSEMBLY			8-1
8.1	Bed Rail Assembly, Front (S/M Type Frame)	8-1	
8.2	Bed Rail Assembly, Rear (S/M Type Frame)	8-2	
8.3	Angled Bed Rail ("S" Type Frame)	8-3	
8.4	Bed Rail Assembly, Front Middle (S/M Type Frame).....	8-5	
8.5	Bed Rail Assembly, Rear Middle	8-6	
8.6	Additional Angled Bed Rail (Long)	8-7	
8.7	Additional Flat Bed Rail (Long)	8-8	
8.8	Additional Flat Bed Rail (Short)	8-9	
8.9	Additional Angled Bed Rail (Short)	8-10	
8.10	Bed Extension LT40 (0.9m) - Complete	8-12	
8.11	Fine Adjust Outrigger Leg	8-14	
8.12	Adjustable Legs	8-16	
8.13	Adjustable legs (M Frame)	8-17	
8.14	Complete Adjustable Leg (at hitch)	8-18	
8.15	Board Return Table Leg - Complete	8-19	
8.16	Angled Bed Rails, "M" Frame	8-20	
8.17	Plate Set, M Type Frame Bed Rail 1-2 & 2-3 (Option)	8-22	

Table of Contents

Section-Page

8.18	Long Table	8-23
8.19	Pivot Bed Rail Assembly.....	8-25
8.20	Bed Rail Assembly, Optional End.....	8-26
8.21	Log Side Support Assembly	8-27
8.22	Tie Down Chain Assembly	8-28
8.23	Saw Head Transport Bracket	8-28
8.24	Saw Head Transport Bracket (for beds w/angled bed rails)	8-30
8.25	Saw Head Rest Bracket (LT20/40 Sawmills).....	8-31
8.26	Saw Head Bracket LT40 WIDE	8-32
8.27	Inspection Platform	8-33
8.28	Inspection Platform (New M-type Frame, Mobile Sawmills)	8-34
8.29	Inspection Platform for Wide "M" Frame	8-35
8.30	Inspection Platform (M-type Frame Sawmills).....	8-36
8.31	Remote Equipment for Installation on a Wall (Cutting Length of 6.5 m)	8-37
8.32	Remote Equipment for Installation on a Wall (Cutting Length of 6.5-10 m).....	8-38
8.33	Guide Rail Support Post.....	8-39
8.34	Guide Rail Support Post.....	8-41
8.35	4-Post Remote Set	8-43
8.36	5-Post Remote Set	8-44
8.37	Octagonal Profile Sawing Tool (Option)	8-45
8.38	Sawmill Transport Bracket Assembly (Option).....	8-46
8.39	Bed Frame Decals	8-47
8.40	Inspection Platform (M-type Frame Sawmills). 555380	8-48
8.41	Stationary Legs for "M" Frame. 522944	8-49
8.42	Stationary Legs for "S" Frame. 526546	8-51

SECTION 9 LOG CLAMP, TURNER, LOADER & TOE BOARDS

9-1

9.1	Manual Log Clamp	9-1
9.2	Log Clamp Assembly.....	9-2
9.3	Manual Log Clamp - Central (546323)	9-4
9.4	Manual Log Turner.....	9-5
9.5	Manual Toe Board.....	9-7
9.6	Manual Log Loader (S/M type frame)	9-8
9.7	Manual Log Loader Pump.....	9-9

SECTION 1 GENERAL INFORMATION

1.1 How To Use the Parts List

- Use the index above to locate the assembly that contains the part you need.
- Go to the appropriate section and locate the part in the illustration.
- Use the number pointing to the part to locate the correct part number and description in the table.
- Parts shown indented under another part are included with that part.
- Parts marked with a diamond (◆) are only available in the assembly listed above the part.

See the sample table below. Sample Part #A01111 includes part F02222-2 and subassembly A03333. Subassembly A03333 includes part S04444-4 and subassembly K05555. The diamond (◆) indicates that S04444-4 is not available except in subassembly A03333. Subassembly K05555 includes parts M06666 and F07777-77. The diamond (◆) indicates M06666 is not available except in subassembly K05555.

1.2 Sample Assembly				
REF.	DESCRIPTION (◆ Indicates Parts Available In Assemblies Only)	PART #	QTY	
	Sample Assembly, Complete (Includes All Indented Parts Below)	A01111	1	
1	Sample Part	F02222-22	1	
	Sample Subassembly (Includes All Indented Parts Below)	A03333	1	
2	Sample Part (◆ Indicates Part Is Only Available With A03333)	S04444-4	1	◆
	Sample Subassembly (Includes All Indented Parts Below)	K05555	1	
3	Sample Part (◆ Indicates Part Is Only Available With K05555)	M06666	2	◆
4	Sample Part	F07777-77	1	

To Order Parts:

- From Europe call our European Headquarters and Manufacturing Facility in Kolo, Poland at **+48-63-2626000**. From the continental U.S., call our toll-free Parts hotline at **1-800-525-8100**. Have your customer number, vehicle identification number, and part numbers ready when you call. From other international locations, contact the Wood-Mizer distributor in your area for parts.

Office Hours:

Country	Monday - Friday	Saturday	Sunday
Poland	7-15	Closed	Closed
US	8 a.m.- 5 p.m.	8 a.m.- 12 p.m.	Closed



CAUTION! It is strongly recommended that only original spare parts be used.

SECTION 2 BLADE GUIDE ROLLERS & ARM

2.1 Blade Guide Assembly, Idle Side (Standard)

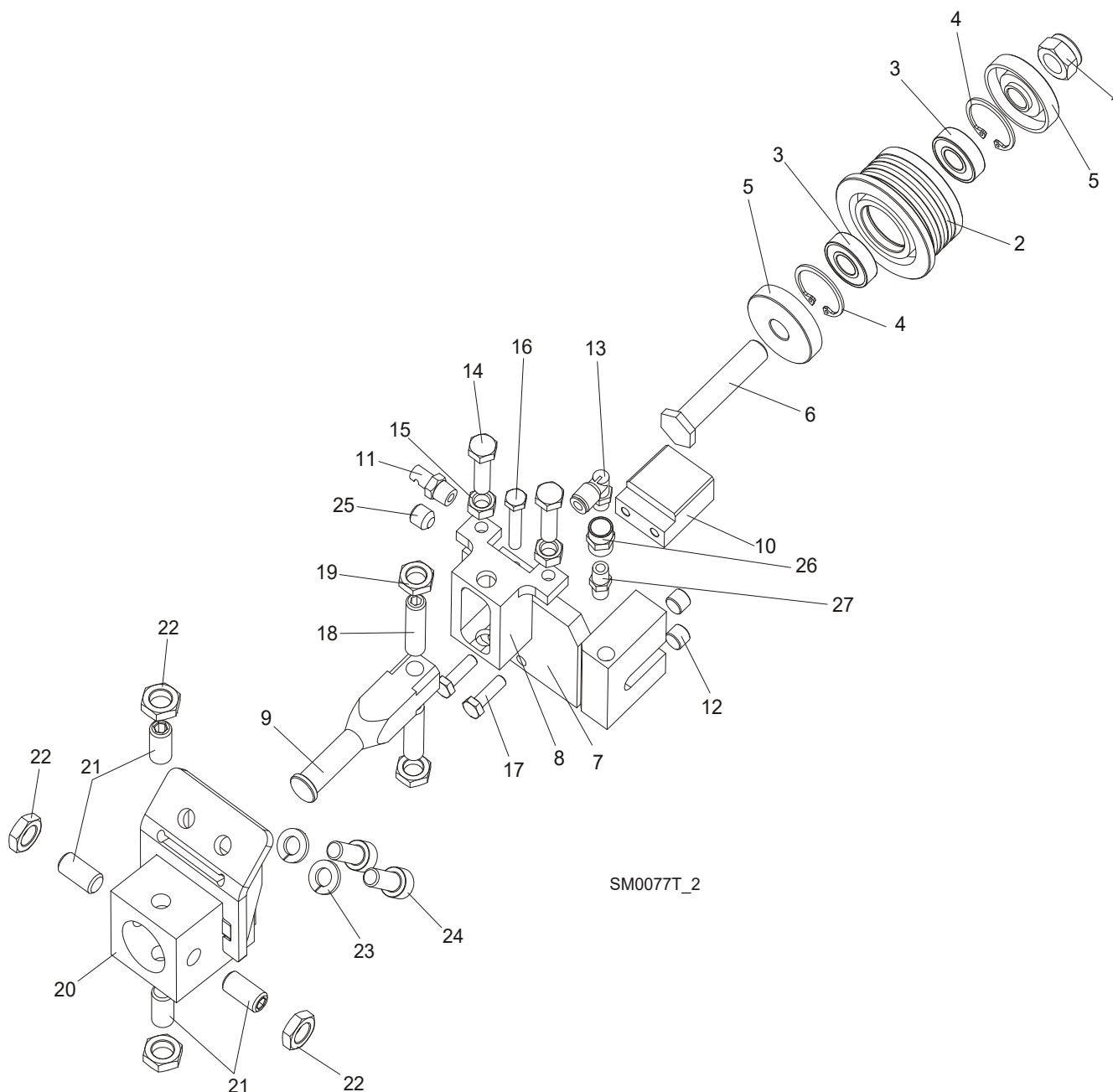

REF.	DESCRIPTION (◆ Indicates Parts Available In Assemblies Only)	PART#	QTY
	BLADE GUIDE ASSEMBLY, IDLE SIDE	092523	1
	BLADE GUIDE ASSEMBLY, IDLE SIDE, EXTENDED (for optional use with 1 1/2" blades)	092994	1
	Roller, Blade Guide Narrow w/Bearings	088261	1
	Roller, Blade Guide w/Bearings Extended (for optional use with 1 1/2" blades)	092939	1
1	Nut, M12-8 Hex Nylon Zinc Lock	F81034-2	1

Blade Guide Rollers & Arm

Blade Guide Assembly, Idle Side (Standard)

2

2	Roller, Blade Guide Narrow	087889	1	
	Roller, Blade Guide Extended (for optional use with 1 1/2" blades)	087890	1	
3	Bearing, 6001 2RSR NACHI	087893	2	
4	Ring, W28 Inside Retaining	F81090-9	2	
5	Washer, Spacer	087891-1	2 (1)	
	Washer, Spacer (used with the Extended Roller only) ¹	087892-1	1	
6	Bolt, Blade Guide Roller Zinc-Plated	087761-1	1	
	Bolt, Blade Guide Roller Zinc-Plated (used with the Extended Roller only)	092940-1	1	
7	Block Weldment, Nozzle Zinc-Plated	087750-1	1	
8	Block, Zinc Plated Roller Guide Adjuster	087756-1	1	
9	Shaft, Zinc-Plated Blade Guide Mount (Narrow Roller)	088255-1	1	
	Shaft, Zinc-Plated Blade Guide Mount (Wide Roller)	501406-1	1	
10	Block, Blade Guide Zinc	096956-1	1	
11	Nozzle, Blade Water Lube Spray	016637	1	
12	Plug, M10x1 DIN 906 BN40 "BOSSARD"	F81015-3	2	
13	Fitting, 90° Elbow 1/8NPT-1/4 Tube Swivel	P09736	1	
14	Bolt, M8x30 DIN933 A2-70 Stainless Steel	F81002-27	2	
15	Nut, M8 DIN934 A2-70 Stainless Steel	F81032-7	2	
16	Bolt, M6x30 DIN933 A2-70 Stainless Steel	F81001-37	1	
17	Bolt, M6x20-8.8 Hex Head Full Thread Zinc	F81001-2	2	
18	Screw, M10x1x40 DIN913 Stainless Steel Set	F81015-2	2	
19	Nut, M10x1-04-ST-A2 ISO 8675 Thin	F81033-10	2	
20	BLOCK WELDMENT, BLADE GUIDE MOUNT	514887-1	1	
21	SCREW, M10X1X25 DIN913 STAINLESS STEEL SET	F81015-4	4	
22	NUT, M10x1-04-ST-A2 ISO 8675 THIN	F81033-10	4	
23	WASHER, 8.2 SPLIT LOCK ZINC	F81054-4	2	
24	BOLT, M8 X 20-8.8 SOCKET HEAD	F81002-30	2	
25	FITTING, 1/8 NPT SOCKET PIPE PLUG	P30127	1	
26	FITTING, 1/8FPT COUPLING	P05748	1	
27	NIPPLE, 1/8 DRY SEAL	P02764	1	

¹ Used only from the flanged side of the roller

2 Blade Guide Rollers & Arm

Blade Guide Assembly, Idle Side (Optional)

2.2 Blade Guide Assembly, Idle Side (Optional)

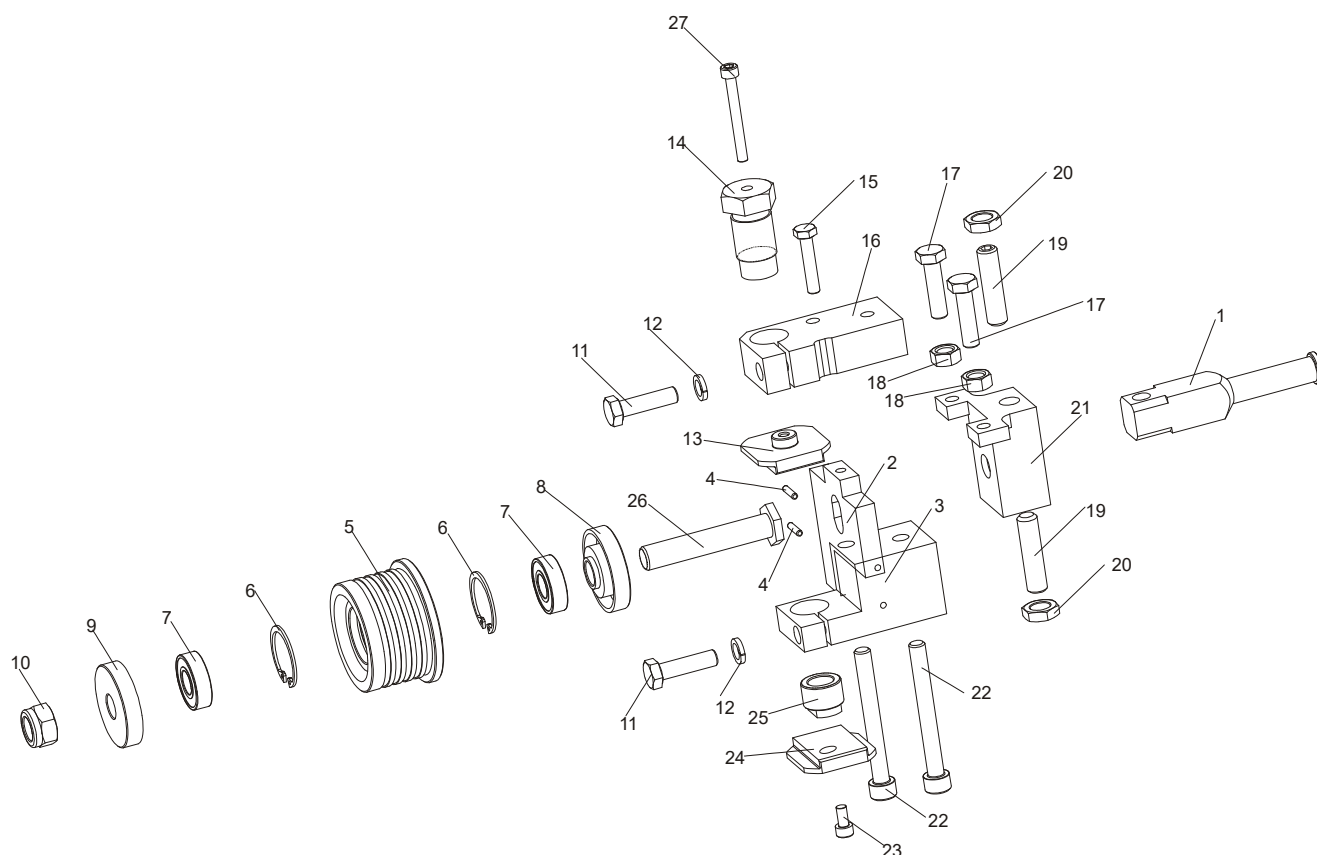

REF.	DESCRIPTION (◆ Indicates Parts Available In Assemblies Only)	PART#	QTY
	BLADE GUIDE ASSEMBLY, IDLE SIDE, EXTENDED (for optional use with 1 1/2" blades)	093760	1
1	SHAFT, ZINC-PLATED BLADE GUIDE MOUNT	501406-1	1
	MOUNTING PLATE ASSEMBLY	093763-1	1
2	PLATE, BLADE GUIDE MOUNTING	093761	1
3	BLOCK, LOWER PAD MOUNT	093769	1
4	PIN, 3m6x14 DIN 6325 HRC 60 ROLL	F81048-6	2
	ROLLER, BLADE GUIDE EXTENDED W/BEARINGS	092939	1
5	ROLLER, BLADE GUIDE EXTENDED	087890-0	1
2	RING, W28 INSIDE RETAINING	F81090-9	2
7	BEARING, 6001 2RSR (FAG,SKF)	087893	2
8	RING, ZINC-PLATED SPACER (FOR EXTENDED ROLLER)	087892-1	1
9	WASHER, ZINC-PLATED SPACER	087891-1	1
10	NUT, M12-8 HEX NYLON ZINC LOCK	F81034-2	1
11	BOLT, M8x30 DIN933 A2-70 STAINLESS STEEL	F81002-27	2
12	WASHER, 8.2 SPLIT LOCK ZINC	F81054-4	2
13	BLOCK, BLADE GUIDE ZINC-PLATED	093430-1	1
14	BOLT, UPPER BLOCK ADJUSTMENT	089515-1	1
15	BOLT, M6x30 DIN933 A2-70 STAINLESS STEEL	F81001-37	1
16	BLOCK, UPPER PAD MOUNT	093762-1	1
17	BOLT, M8x30 DIN933 A2-70. STAINLESS STEEL	F81002-27	2
18	NUT, M8 DIN 934 A2-70 STAINLESS STEEL	F81032-7	2
19	SCREW, M10x1x40 DIN913 SET STAINLESS STEEL	F81015-2	2

Blade Guide Rollers & Arm

Blade Guide Assembly, Idle Side (Optional)

2

20	NUT, PN-EN ISO 8675-M10X1-04-St-A2 HEX THIN FINE THREAD	F81033-10	2	
21	BLOCK, BLADE DEFLECTION ADJUSTMENT	087756-1	1	
22	SCREW, M8x40-8.8 HEX SOCKET HEAD CAP ZINC	F81002-29	2	
23	SCREW, M5X10 DIN 912 A2-70 HEX SOCKET HEAD CAP STAINLESS STEEL	F81000-23	1	
24	BLOCK, BLADE GUIDE ZINC-PLATED	093430-1	1	
25	SCREW, LOWER PAD ADJUSTMENT	090945-1	1	
26	BOLT, EXT. BLADE GUIDE ROLLER LONG	092940-1	1	

2 Blade Guide Rollers & Arm

Blade Guide Assembly, Drive Side (Optional)

2.3 Blade Guide Assembly, Drive Side (Optional)

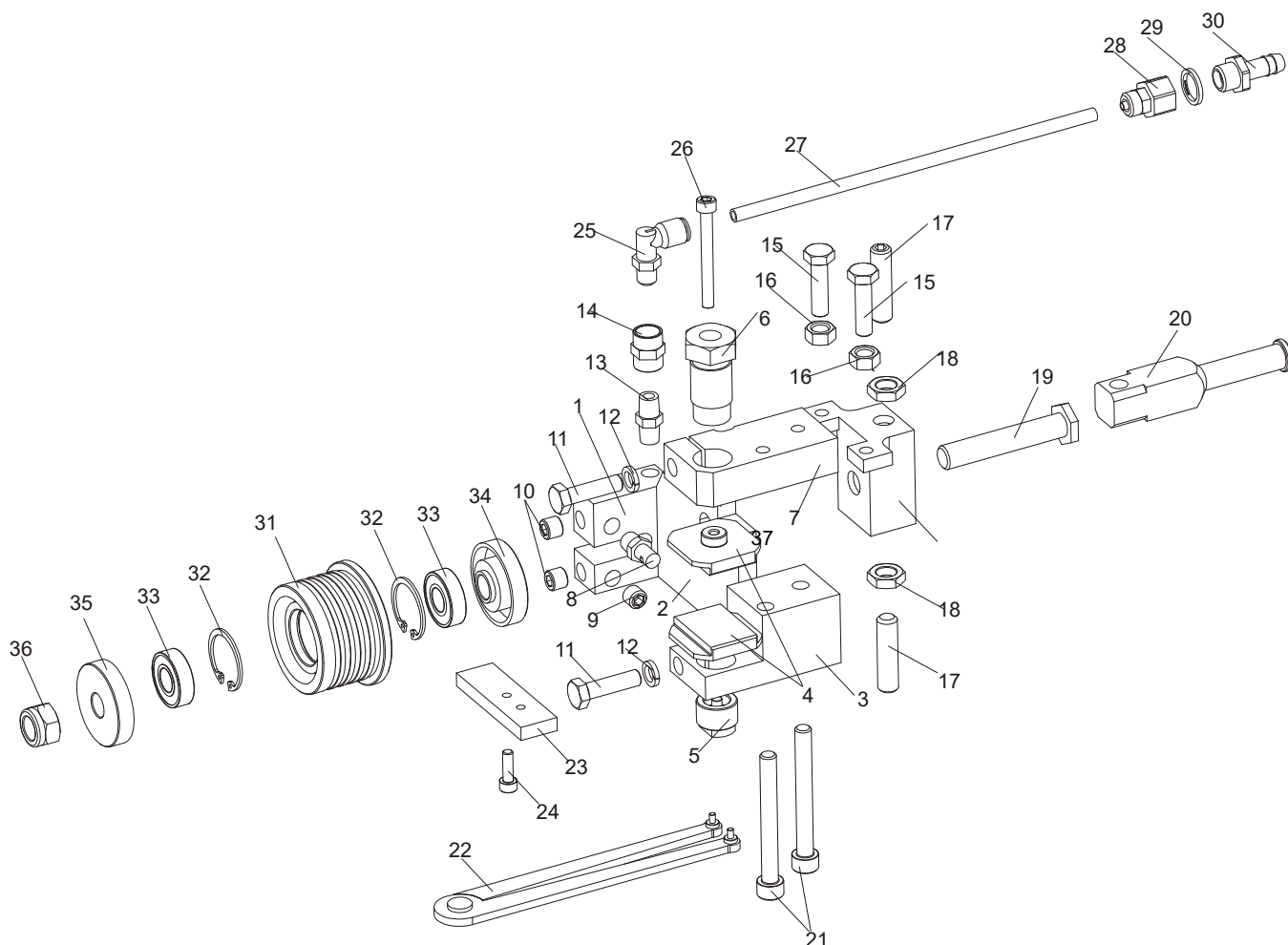

REF.	DESCRIPTION (◆ Indicates Parts Available In Assemblies Only)	PART#	QTY
	BLADE GUIDE ASSEMBLY,DRIVE SIDE, EXTENDED (for optional use with 1 1/2" blades)	093768	1
	NOZZLE & LOWER BLOCK MOUNT WELDMENT	093765	1
1	BLOCK WELDMENT, NOZZLE MOUNTING	087751	1
2	PLATE WELDMENT, MAIN	093766	1
3	BLOCK, LOWER PAD MOUNT (LEFT)	093767	1
4	BLOCK, BLADE GUIDE ZINC-PLATED	093430-1	2
5	SCREW, LOWER PAD ADJUSTMENT ZINC-PLATED	090945-1	1
6	BOLT, UPPER BLOCK ADJUSTMENT ZINC-PLATED	089515-1	1
7	BLOCK, UPPER PAD MOUNT ZINC-PLATED	093762-1	1
8	NOZZLE, BLADE WATER LUBE	016637	1
9	FITTING, 1/8 NPT SOCKET PIPE PLUG	P30127	1
10	PLUG, M10X1 DIN906 BN40 ZINC-PLATED	F81015-3	2
11	BOLT, M8X30 DIN933 A2-70 STAINLESS STEEL	F81002-27	2
12	WASHER, 8.2 SPLIT LOCK ZINC	F81054-4	2
13	NIPPLE, 1/8 DRY SEAL	P02764	1
14	FITTING, 1/8FPT COUPLING	P05748	1
15	BOLT, M8X30 DIN933 A2-70 STAINLESS STEEL	F81002-27	2
16	NUT, M8 DIN 934 A2-70 STAINLESS STEEL	F81032-7	2

Blade Guide Rollers & Arm

Blade Guide Assembly, Drive Side (Optional)

2

17	SCREW, M10X1X40 DIN913 A2-70 STAINLESS STEEL SET	F81015-2	2	
18	NUT, PN-EN ISO 8675-M10X1-04-ST-A2 HEX THIN W/FINE THREAD	F81033-10	2	
19	BOLT, EXT.BLADE GUIDE ROLLER LONG ZINC-PLATED	092940-1	1	
20	SHAFT, ZINC-PLATED BLADE GUIDE MOUNT	501406-1	1	
21	SCREW, M8X40-8.8 HEX SOCKET HEAD CAP ZINC	F81002-29	2	
22	SPANNER, 62860-3 (Perschmann) ADJUSTABLE	090949	1	
	PLATE, BLADE GUIDE ADJUSTMENT COMPLETE	090951	1	
23	PLATE, BLADE GUIDE ADJUSTMENT ZINC-PLATED	090805-1	1	
24	SCREW, M5X16-8.8 HEX SOCKET HEAD CAP ZINC	F81000-25	1	
25	ELBOW, 90 DEG. 1/8MPT 1/4 TUBE SWIVEL	P09736	1	
26	SCREW, M5x45 DIN912 A2-70 HEX SOCKET HEAD CAP STAINLESS STEEL	F81000-24	1	
	FITTING, 10/6.35 COMPLETE REDUCER	092782	1	
27	CABLE, COMPLETE REDUCER FITTING	092785	1	
28	FITTING, MV13/06 nr 13700 (RECTUS)	092784	1	
29	SEAL, G1/4 866-014-000-0 (REXROTH)	090809	1	
30	BUSHING, GT13/09 nr 13539 (RECTUS)	092783	1	
	ROLLER, BLADE GUIDE EXTENDED W/BEARINGS	092939	1	
31	ROLLER, BLADE GUIDE EXTENDED	087890	1	
32	RING, W28 INSIDE RETAINING	F81090-9	2	
33	BEARING, 6001 2RSR (FAG, SKF)	087893	2	
34	RING, ZINC-PLATED SPACER	087892-1	1	
35	RING, ZINC-PLATED SPACER	087891-1	1	
36	NUT, M12-8 HEX NYLON ZINC LOCK	F81034-2	1	
37	BLOCK, BLADE DEFLECTION ADJUSTMENT ZINC-PLATED	087756-1	1	

2 Blade Guide Rollers & Arm

Blade Guide Mount Block (LT40 Wide)

2.4 Blade Guide Mount Block (LT40 Wide)

544238_001
544238_MANUAL

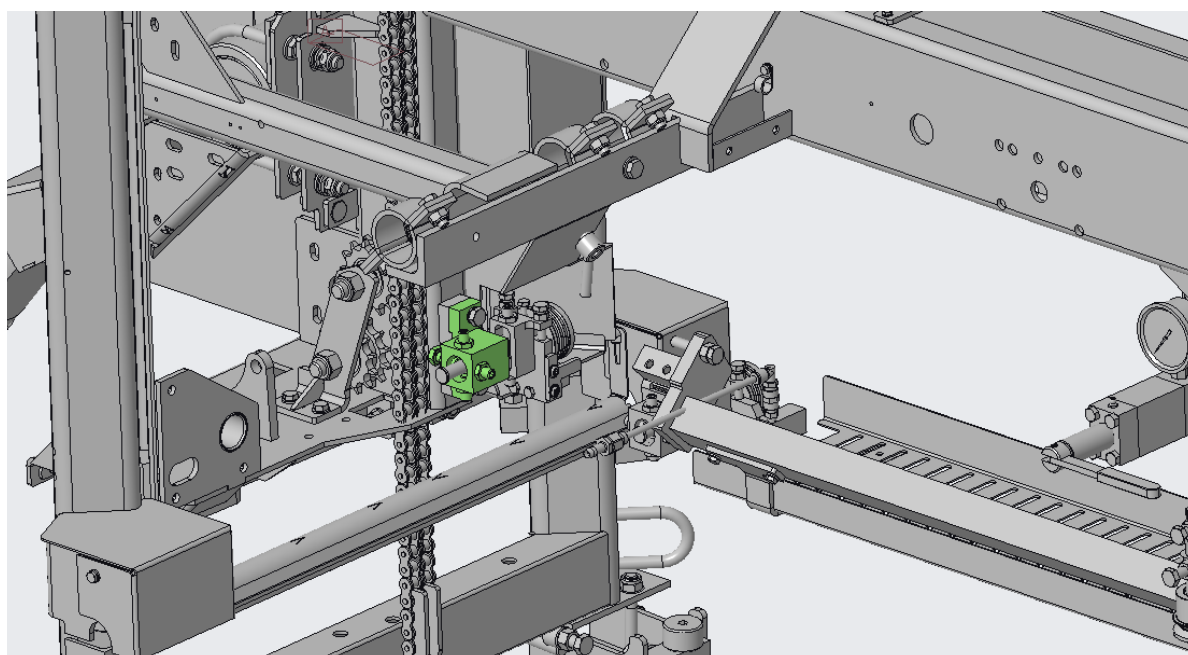
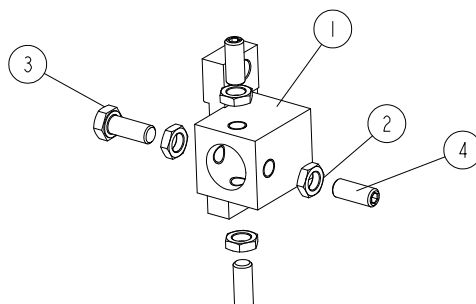

REF.	DESCRIPTION (* indicates parts available in assemblies only)	PART #	QTY
-	BLOCK, BLADE GUIDE MOUNT - COMPLETE	544238	1
1	BLOCK WELDMENT, BLADE GUIDE MOUNT	087744-1	1
2	NUT, M10X1-04-ST-A2E ISO8675 THIN	F81033-10	4
3	BOLT, M10X1X25 DIN 933 STAINLESS STEEL	F81003-28	1
4	SCREW, M10X1X25 DIN 913 STAINLESS STEEL SET	F81015-4	3

2.5 Blade Guide Mount Block (LT40 Wide)

544242_001
 544242_MANUAL

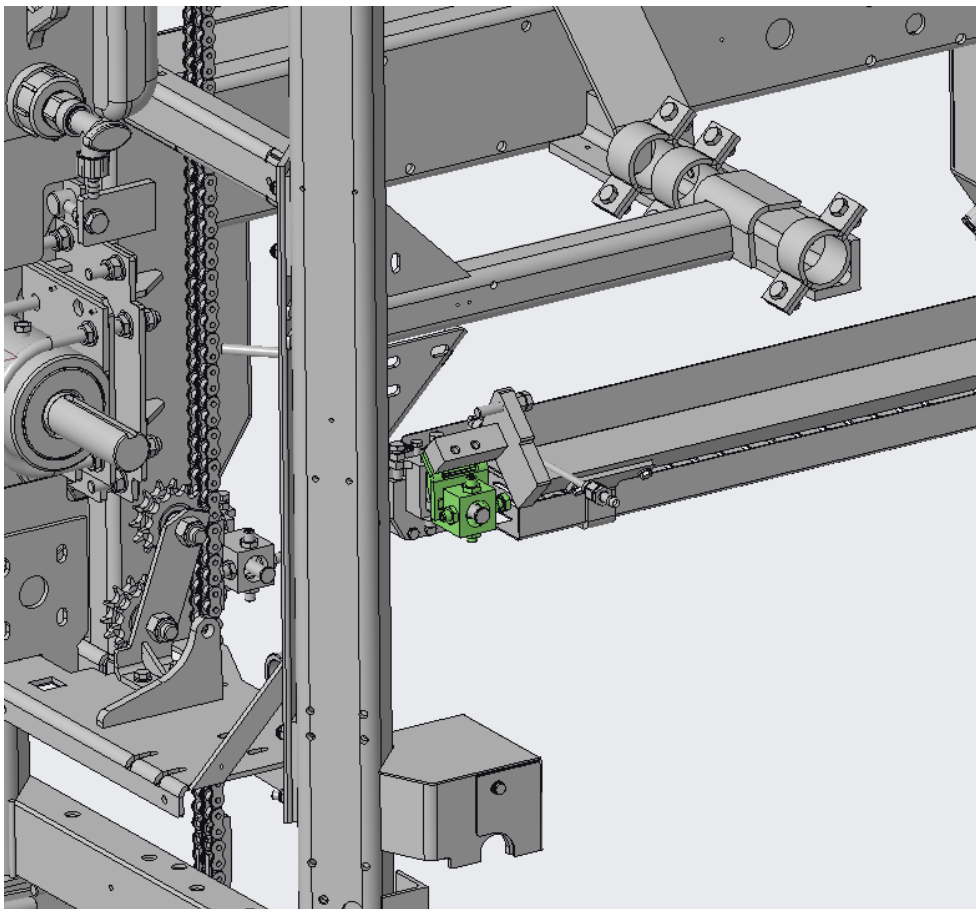
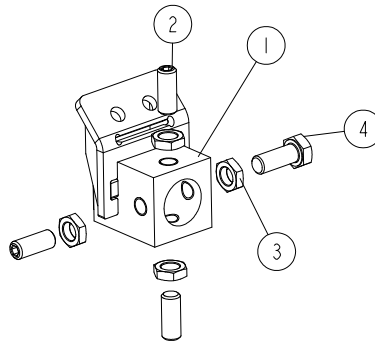

REF.	DESCRIPTION (* indicates parts available in assemblies only)	PART #	QTY
1	BLOCK WELDMENT, LEFT BLADE GUIDE MOUNT - COMPLETE	514887-1	1
2	SCREW, M10X1X25 DIN 913 STAINLESS STEEL SET	F81015-4	3
3	NUT, M10X1-04-ST-A2E ISO8675 THIN	F81033-10	4
4	BOLT, M10X1X25 DIN 933 STAINLESS STEEL	F81003-28	1

2 Blade Guide Rollers & Arm

Idle Side Blade Guide Assembly, Optional (LMS)

2.6 Idle Side Blade Guide Assembly, Optional (LMS)

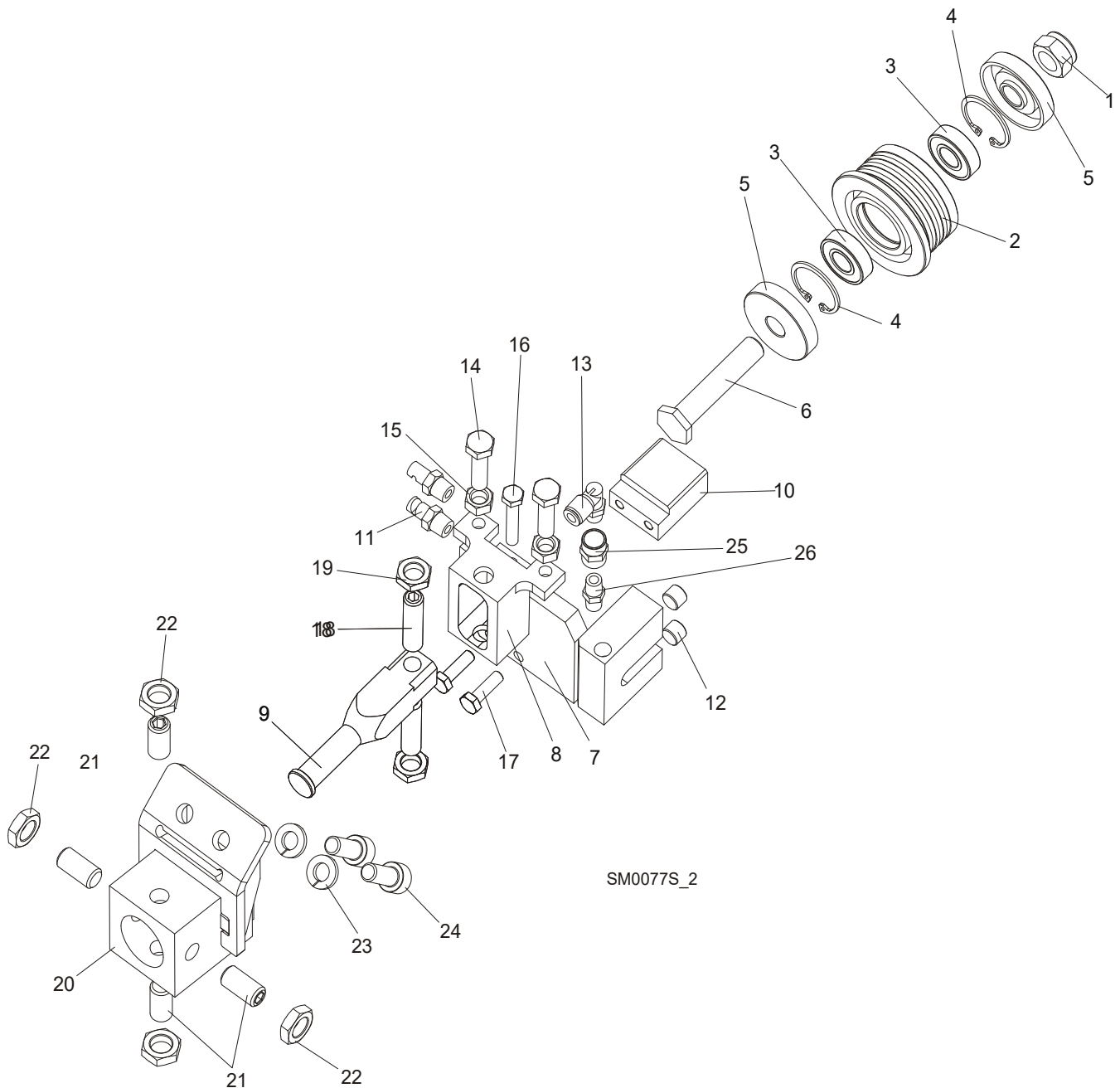

SM0077S_2

REF.	DESCRIPTION (◆ Indicates Parts Available In Assemblies Only)	PART#	QTY
	BLADE GUIDE ASSEMBLY, IDLE SIDE	087749	1
	BLADE GUIDE ASSEMBLY, IDLE SIDE. EXTENDED (for optional use with 1 1/2" blades)	092996	1
	Roller, Blade Guide Narrow w/Bearings	088261	1
	Roller, Blade Guide w/Bearings Extended (for optional use with 1 1/2" blades)	092939	1
1	Nut, M12-8 Hex Nylon Zinc Lock	F81034-2	1
2	Roller, Blade Guide Narrow	087889	1

	Roller, Blade Guide Extended (for optional use with 1 1/2" blades)	087890	1	
3	Bearing, 6001 2RSR NACHI	087893	2	
4	Ring, W28 Inside Retaining	F81090-9	2	
5	Washer, Spacer	087891	2 (1)	
	Washer, Spacer (used with the Extended Roller only) ¹	087892-1	1	
6	Bolt, Blade Guide Roller Zinc-Plated	087761-1	1	
	Bolt, Blade Guide Roller Zinc Plated (used with the Extended Roller only)	092940-1	1	
7	Block Weldment, Nozzle Zinc-Plated	087750-1	1	
8	Block, Zinc-Plated Roller Guide Adjuster	087756-1	1	
9	Shaft, Zinc-Plated Blade Guide Mount (Narrow Roller)	088255-1	1	
	Shaft, Zinc-Plated Blade Guide Mount (Wide Roller)	501406-1	1	
10	Block, Blade Guide Zinc	096956-1	1	
11	Nozzle, Blade Lube Spray	033479	2	
12	Plug, M10x1 DIN 906 BN40 "BOSSARD"	F81015-3	2	
13	Fitting, 90° Elbow 1/8NPT-1/4 Tube Swivel	P09736	1	
14	Bolt, M8x30 DIN933 A2-70 Stainless Steel	F81002-27	2	
15	Nut, M8 DIN934 A2-70 Stainless Steel	F81032-7	2	
16	Bolt, M6x30 DIN933 A2-70 Stainless Steel	F81001-37	1	
17	Bolt, M6x20-8.8 Hex Head Full Thread Zinc	F81001-2	2	
18	Screw, M10x1x40 DIN913 Stainless Steel Set	F81015-2	2	
19	Nut, M10x1-04-ST-A2 ISO 8675 Thin	F81033-10	2	
20	BLOCK WELDMENT, PAINTED BLADE GUIDE MOUNT	514887-1	1	
21	SCREW, M10X1X25 DIN913 STAINLESS STEEL SET	F81015-4	4	
22	NUT, M10x1-04-ST-A2 ISO 8675 THIN	F81033-10	4	
23	WASHER, 8.2 SPLIT LOCK ZINC	F81054-4	2	
24	BOLT, M8 X 20-8.8 SOCKET HEAD	F81002-30	2	
25	FITTING, 1/8FPT COUPLING	P05748	1	
26	NIPPLE, 1/8 DRY SEAL	P02764	1	

¹ Used only from the flanged side of the roller

2.7 Blade Guide Assembly, Drive Side

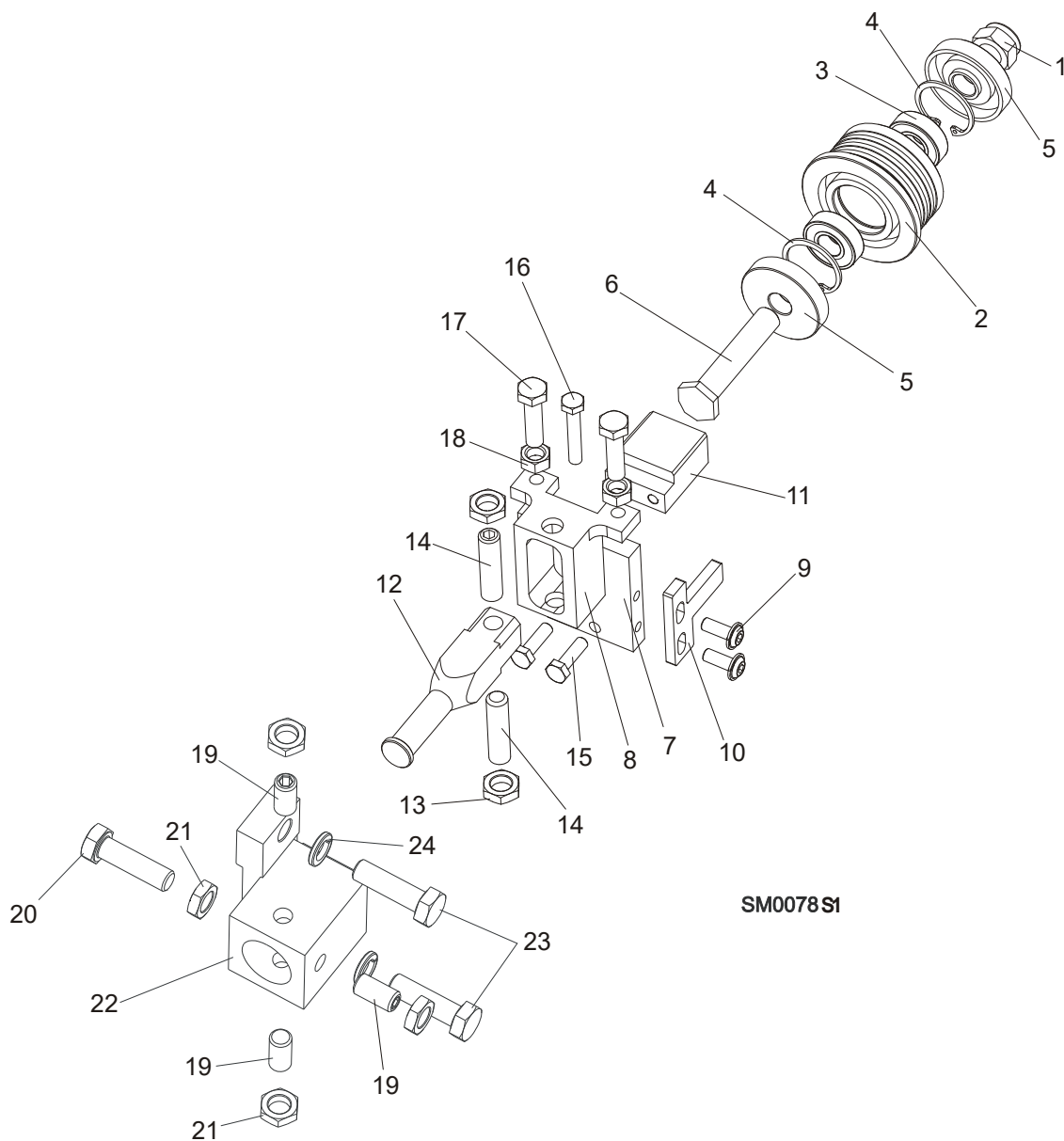

REF.	DESCRIPTION (◆ Indicates Parts Available In Assemblies Only)	PART#	QTY
	BLADE GUIDE ASSEMBLY, DRIVE SIDE	087748	1
	BLADE GUIDE ASSEMBLY, DRIVE SIDE, Extended (for optional use with 1 1/2" blades)	092995	1
	Roller, Blade Guide Narrow w/Bearings	088261	1
	Roller, Blade Guide w/Bearings Extended (for optional use with 1 1/2" blades)	092939	1
1	Nut, M12-8 Hex Nylon Zinc Lock	F81034-2	1
2	Roller, Blade Guide Narrow	087889	1
	Roller, Blade Guide Extended (for optional use with 1 1/2" blades)	087890	1
3	Bearing, 6001 2RSR NACHI	087893	2

4	Ring, W28 Inside Retaining	F81090-9	1	
5	Washer, Spacer	087891	2 (1)	
	Washer, Spacer (used with the Extended Roller only) ¹	087892-1	1	
6	Bolt, Blade Guide Roller Zinc-Plated	087761-1	1	
	Bolt, Blade Guide Roller Zinc Plated (used with the Extended Roller only)	092940-1	1	
7	Plate, Zinc-Plated Blade Guide Mounting	087753-1	1	
8	Block, Zinc-Plated Roller Guide Adjuster	087756-1	1	
9	Screw, M6x16 BN 11252 "BOSSARD"	F81001-24	2	
10	Wiper, Blade Zinc-Plated	087757-1	1	
11	Block, Blade Guide Zinc	096956-1	1	
12	Shaft, Zinc-Plated Blade Guide Mount (Narrow Roller)	088255-1	1	
	Shaft, Zinc-Plated Blade Guide Mount (Wide Roller)	501406-1	1	
13	Nut, M10x1-04-ST-A2 ISO 8675 Thin	F81033-10	2	
14	Screw, M10x1x40 DIN913 Stainless Steel Set	F81015-2	2	
15	Bolt, M6x20-8.8 Hex Head Full Thread Zinc	F81001-2	2	
16	Bolt, M6x30 DIN933 A2-70 Stainless Steel	F81001-37	1	
17	Bolt, M8x30 DIN933 A2-70 Stainless Steel	F81002-27	2	
18	Nut, M8 DIN934 A2-70 Stainless Steel	F81032-7	2	
19	Screw, M10X1X25 DIN913 Stainless Steel Set	F81015-4	3	
20	BOLT, M10X1X25 DIN 933 STAINLESS STEEL	F81003-28	1	
21	NUT, M10x1-04-ST-A2 ISO 8675 THIN	F81033-10	4	
22	BLOCK WELDMENT, BLADE GUIDE MOUNT	087744	1	
23	BOLT, M10X35-8.8 HEX HEAD FULL THREAD ZINC	F81003-17	2	
24	WASHER, 10.2 SPLIT LOCK ZINC	F81055-2	2	

¹ Used only from the flanged side of the roller

2 Blade Guide Rollers & Arm

Blade Guide Arm & Rollers

2.8 Blade Guide Arm & Rollers

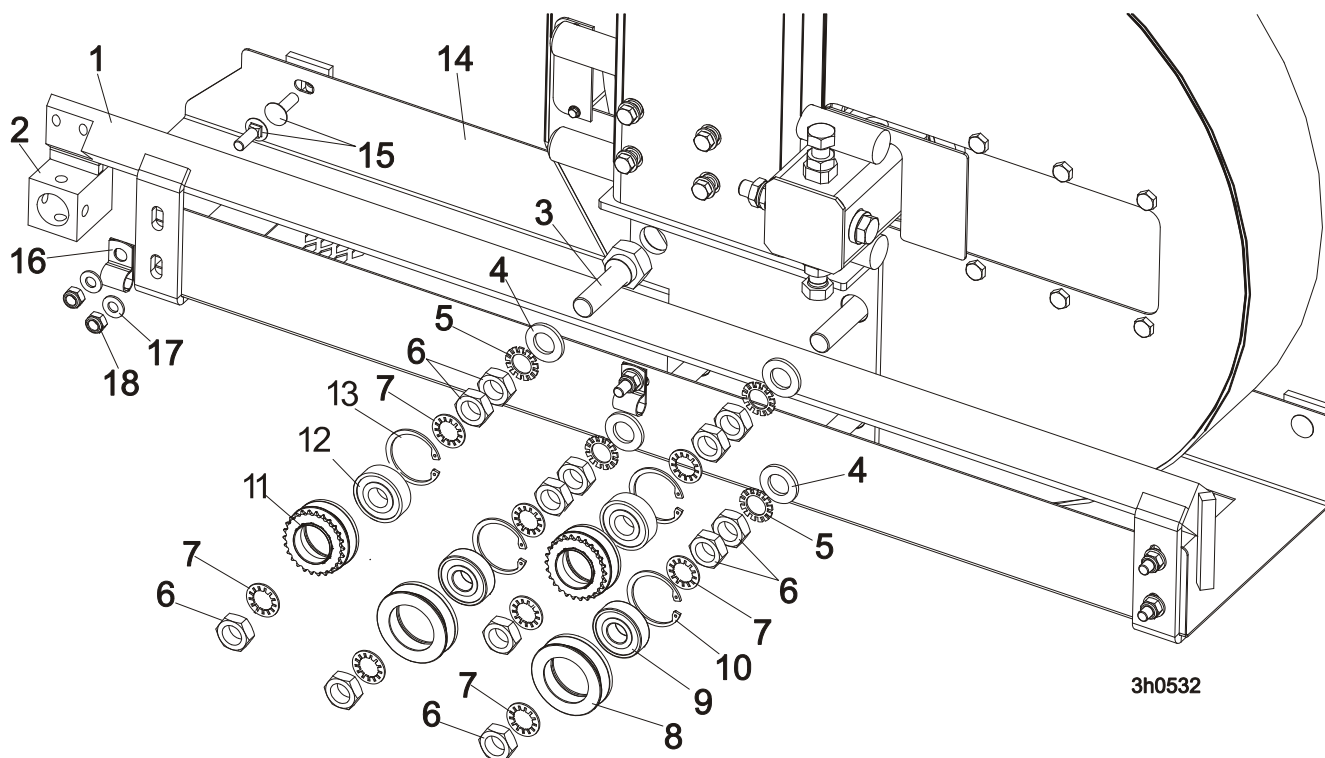

REF.	DESCRIPTION (◆ Indicates Parts Available in Assemblies Only)	PART #	QTY	
1	BLADE GUIDE ARM WELDMENT	505934-1	1	
2	BLOCK WELDMENT, PAINTED BLADE GUIDE MOUNT	514887-1	1	
3	BOLT, BLADE GUIDE ARM ROLLER CAM	086508-1	4	
	BOLT, BLADE GUIDE ARM ROLLER CAM/HARDWOODS	505113-1 ¹	1	
4	WASHER, 17 FLAT	F81058-1	4	
5	WASHER, 5/8" EXTERNAL STAR	F05011-26	4	
6	NUT, 5/8-18 HEX JAM	F05010-11	12	
7	WASHER, 5/8" INTERNAL STAR	F05011-25	8	
	ROLLER ASSEMBLY, BLADE GUIDE ARM WITH BEARING	093855	2	
8	Roller, Blade Guide Arm V-Groove	093856-1	1	◆
9	Bearing, 6203-2RSP6-5/8 CX	095087	1	
10	Ring, W40 Retaining	F81090-3	1	
	ROLLER ASSEMBLY, BLADE GUIDE ARM WITH BEARING AND SPROCKET	501496	2	
11	Roller, Blade Guide Arm w/Sprocket	501495-1	1	◆
12	Bearing, 6203-2RSP6-5/8 CX	095087	1	
13	Ring, W40 Retaining	F81090-3	1	◆
14	GUIDE, BLADE	087042-1	1	
15	BOLT, M8x20-8.8 CARRIAGE ZINC	F81002-11	7	
16	CLAMP, 1/2EMT COATED	P07584	2	
17	WASHER, 8.4 FLAT ZINC	F81054-1	7	
18	NUT, M8-8-B HEX NYLON ZINC LOCK	F81032-2	7	

¹ Mount instead of one 086508-1 bolt in LT40 saw head for hardwoods.

2.9 Blade Guide Arm Drive Assembly

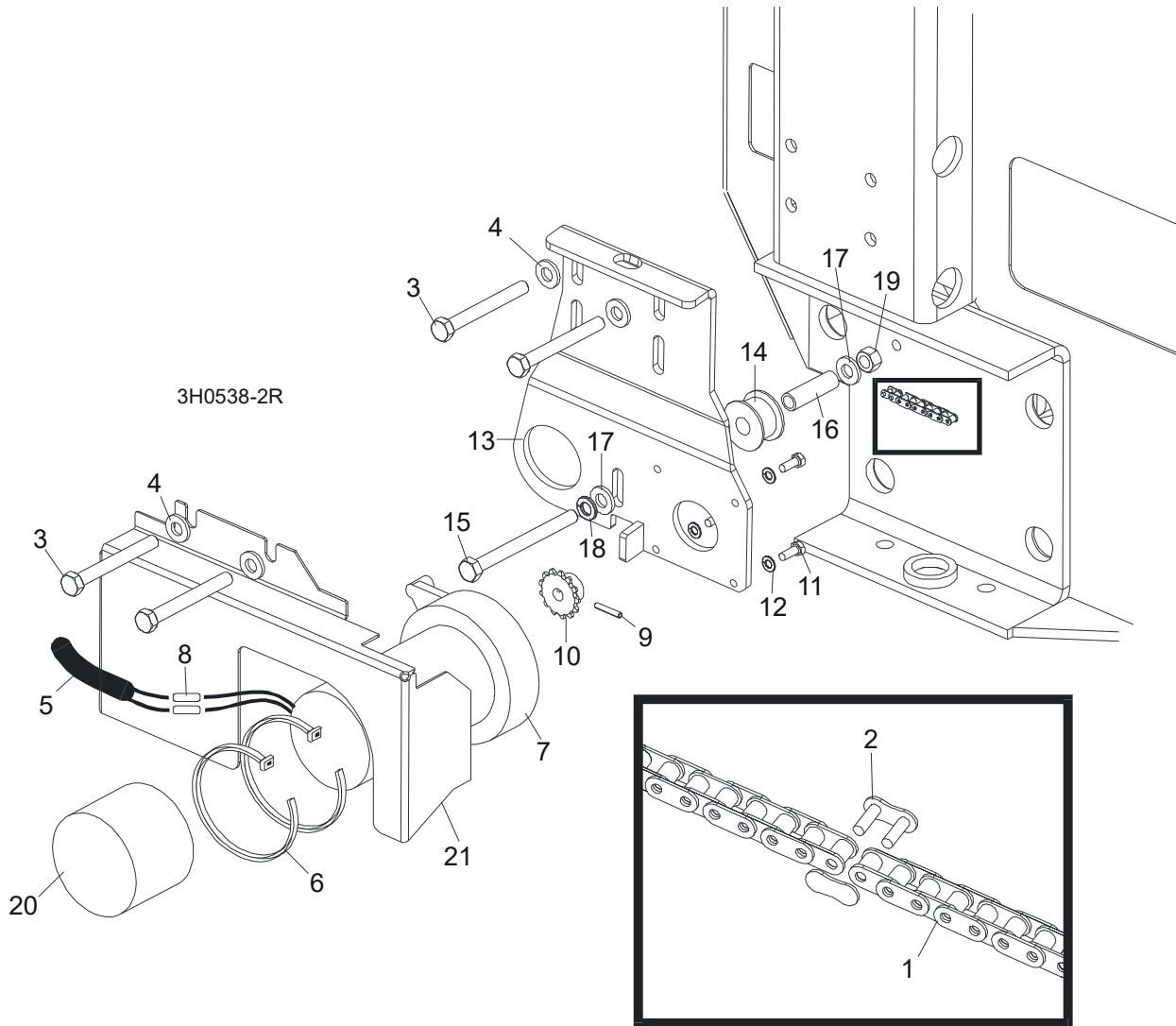

REF.	DESCRIPTION (◆ Indicates Parts Available in Assemblies Only)	PART #	QTY
1	CHAIN, #25 X 20 1/4"	P09984	1
2	LINK, #25 MASTER	P09983	1
3	BOLT, 5/16-18 X 2 3/4" HEX HEAD GRADE 5	F05006-28	4
4	WASHER, 8.4 FLAT	F81054-1	4
5	TUBE, 3/8" X 1/2" NEOPRENE	R01897	0.75 m
6	WRAP, 1/4" X 6" TIE	F05089-1	2
	DRIVE ASSEMBLY, BLADE GUIDE ARM	091005	1
7	Motor, Current Applications 1/30HP 12VDC Gear	079214	1
	Gear Kit, Motor Replacement	061232	1
	Brush Kit, Gear Motor Replacement	061234	1
	Shaft Kit, Gear Motor Replacement	061233	1
8	Connector, 14 Gauge Butt	F04875-1	2
9	Pin, 1/8" X 3/4" Roll	F05012-6	1

2

Blade Guide Rollers & Arm

Blade Guide Arm Drive Assembly

10	Sprocket, Gear Motor #25 14-Tooth	P09970	1	
11	Screw, #10-32 x 1/2" Hex Head	F05004-60	4	
12	Washer, 5.1 Split Lock	F81052-2	4	
	Instruction Sheet, Blade Guide Arm Motor	A10353-296	1	
13	Bracket, Blade Guide Arm Motor Mount	087994-1	1	
14	Roller, Blade Guide Arm Chain Idler	516193	1	
15	Bolt, M8x90-8.8 Hex Head Full Thread	F81002-16	1	
16	Bushing, 12/8-38 Zinc	516239-1	1	
17	Washer, 5/16" SAE Flat	F81054-1	3	
18	Washer, 8.2 Split Lock	F05011-13	1	
19	Nut, M8-8-B Hex Lock	F81032-1	1	
20	Boot, Gear Motor Weather	023720	1	
21	COVER, BLADE GUIDE ARM MOTOR	093460-1	1	

2.10 Drive Assembly, Blade Guide Arm (LT40 Wide)

540129_001
 540129_MANUAL

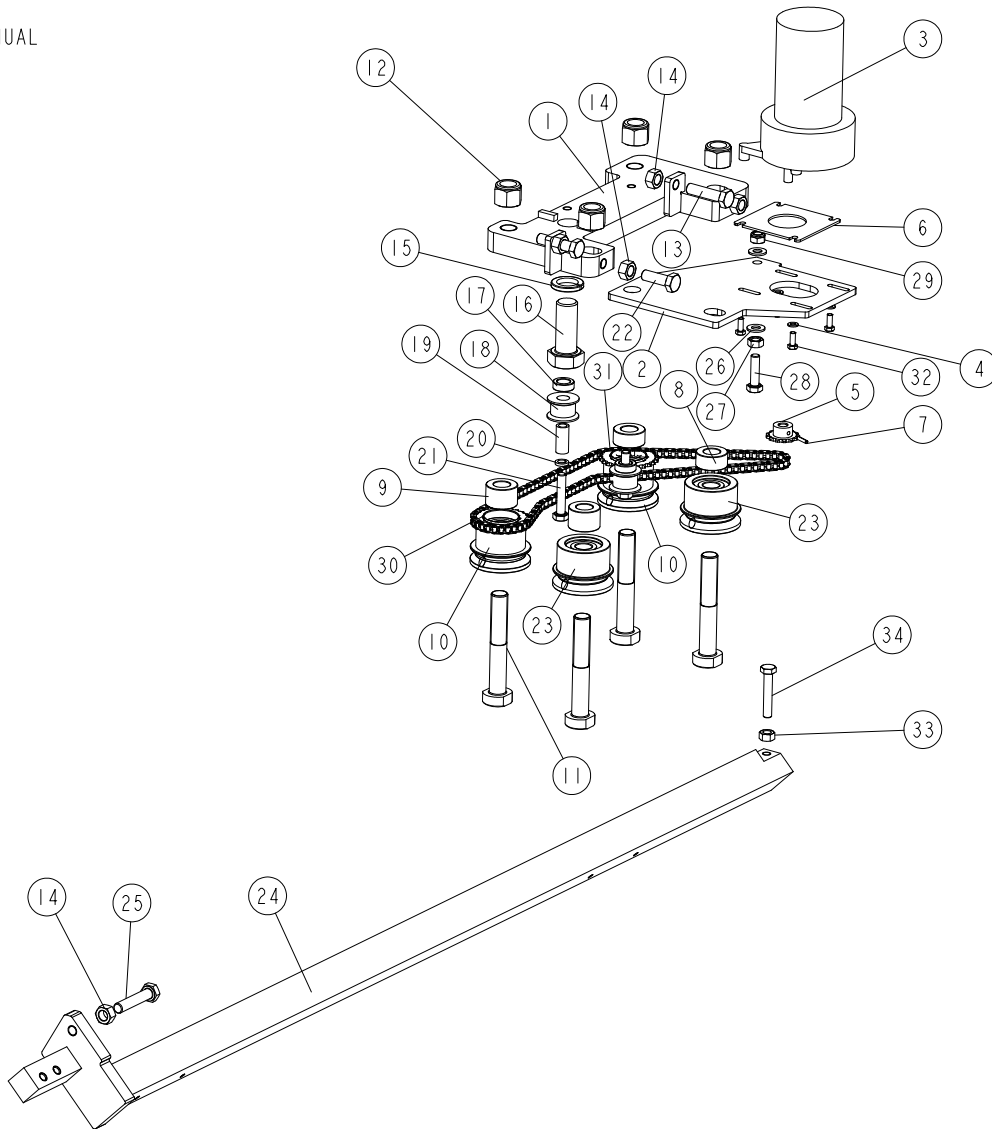

REF.	DESCRIPTION (* indicates parts available in assemblies only)	PART #	QTY	
-	Drive Assembly, Blade Guide Arm	540129	1	
1	PLATE, ARM DRIVE MOUNT	540124-1	1	
2	PLATE, ARM MOTOR MOUNT	557375-1	1	
3	MOTOR, CURRENT APP. 1/30HP 12VDC GEAR	557161	1	
4	WASHER, 5.3 FLAT ZINC	F81052-1	4	
5	SPROCKET, 25B13X.3130	P09970	1	
6	PLATE, SPACER	557376-1	1	
7	PIN, 3X14 GEOMET ROLL	F81044-4	1	
8	BUSHING, SPACER	520284-1	2	
9	BUSHING, SPACER	520285-1	2	
10	ROLLER, COMPLETE DRIVE See Section 2.11	520282	2	
11	PIN, MOUNT	519660-1	4	
12	NUT, 5/8-18 NYLON ZINC LOCK	F05010-71	4	
13	BOLT, M10X40-8.8 HEX HEAD FULL THREAD ZINC	F81003-16	2	

2

Blade Guide Rollers & Arm*Drive Assembly, Blade Guide Arm (LT40 Wide)*

REF.	DESCRIPTION (* indicates parts available in assemblies only)	PART #	QTY
14	NUT, M10 8 HEX ZINC	F81033-3	5
15	WASHER, 20.5 SPLIT LOCK ZINC	F81059-1	1
16	BOLT, M20X50-8.8-B HEX HEAD FULL THREAD ZINC	F81007-17	1
17	BUSHING, 12.5/20-7 ZINC-PLATED	101063-1	2
18	ROLLER, CHAIN TENSION	516193	2
19	BUSHING, SPACER	519345-1	2
20	WASHER, 8.2 SPLIT LOCK ZINC	F81054-4	2
21	BOLT, M8X40-8.8 HEX HEAD FULL THREAD ZINC	F81002-15	2
22	SCREW, DIN933-M10X30-8.8-A2E HEX CAP FULL THREAD	F81003-111	2
23	ROLLER, IDLER See Section 2.12	520839	2
24	ARM, BLADE GUIDE	540126-1	1
25	BOLT, M10X50-8.8 HEX HEAD FULL THREAD ZINC	F81003-4	1
26	WASHER, 8.4 FLAT ZINC	F81054-1	2
27	NUT, M8 DIN 934 A2-70 STAINLESS STEEL	F81032-7	1
28	BOLT, M8X30 8.8 HEX HEAD FULL THREAD ZINC	F81002-7	1
29	NUT, M8-8-B HEX NYLON ZINC LOCK	F81032-2	1
-	CHAIN, DRIVE	519358	1
30	LINK, 25 MASTER	P09983	1
31	CHAIN, NO.#25X131-LINK	521494	1
32	BOLT, #10-32X1/2 HEX HEAD	F81000-35	4
33	NUT, M8-8-B HEX ZINC	F81032-1	1
34	BOLT, M8X45-8.8 HEX HEAD FULL THREAD ZINC	F81002-14	1

2.11 Drive Roller, Blade Guide Arm

520282_001
 520282_MANUAL

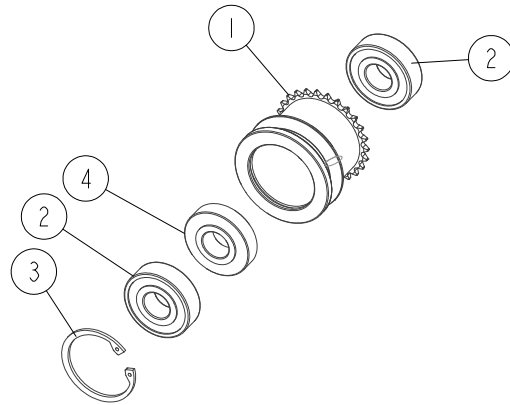

REF.	DESCRIPTION (* indicates parts available in assemblies only)	PART #	QTY	
-	ROLLER, COMPLETE DRIVE	520282	1	
1	ROLLER, W/SPROCKET	520281-1	1	
2	BEARING, 6203 2RSP6- 5/8 CX	095087	2	
3	RING, W40 INSIDE RETAINING	F81090-3	1	
4	BUSHING, SPACER	520283-1	1	

2 Blade Guide Rollers & Arm

Idler Roller, Blade Guide Arm

2.12 Idler Roller, Blade Guide Arm

520839_001
520839_MANUAL

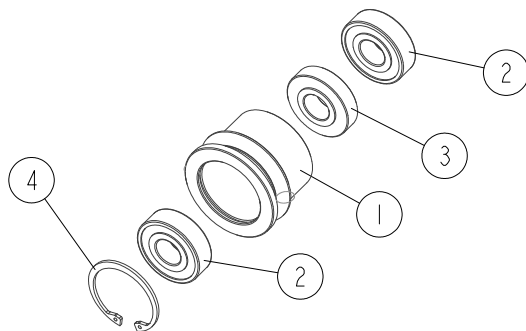

REF.	DESCRIPTION (* indicates parts available in assemblies only)	PART #	QTY	
-	ROLLER, IDLER	520839	1	
1	ROLLER, IDLER	520829-1	1	
2	BEARING, 6203 2RSP6- 5/8 CX	095087	2	
3	BUSHING, SPACER	520283-1	1	
4	RING, W40 INSIDE RETAINING	F81090-3	1	

SECTION 3 BLADE WHEELS & TENSIONER

3.1 Blade Drive Assembly

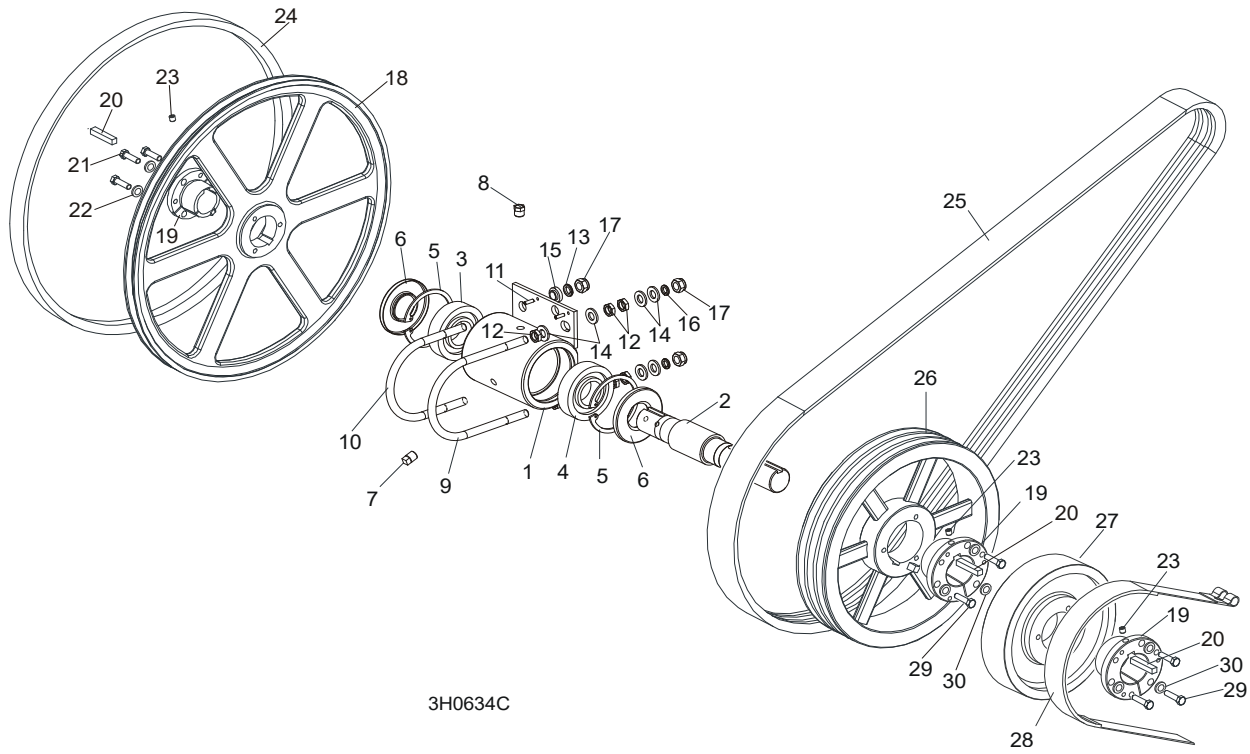

REF.	DESCRIPTION (◆ Indicates Parts Available in Assemblies Only)	PART #	QTY
	BEARING ASSEMBLY, DRIVE	086291	1
1	Housing, Blade Wheel Drive Bearing	086293	1
2	Shaft, Blade Wheel Drive	086292	1
3	Bearing, Blade Wheel Drive NJ308	085939	1
4	Bearing, Blade Wheel Drive #6308	085940	1
5	Ring, 90mm Interior Retaining #I17	F04254-17	2
6	Seal, Drive Bearing #CR15890	P10206	2
7	Plug, 1/4" NPT Square Head	P05498	1
8	Plug, 1/4" NPT Vented	P12868	1
9	Bolt, 1/2-13 Long U	S10207-1P	1
10	Bolt, 1/2-13 Short U	S10207-2P	1
11	Pin, 3/16" X 5/8" Roll	F05012-22	2
12	Nut, M12-04-A Hex Jam	F81034-6	6
13	Washer, 12.2 Split Lock	F81056-2	2
14	Washer, 13 SAE Flat	F81056-1	8
15	Spacer, Zinc	086769-1	2
16	Washer, 10.2 Split Lock Zinc	F81055-2	2
17	Nut, M12-8 Hex Nylon Lock	F81034-2	4
	WHEEL KIT, DRIVE SIDE BLADE	014562	1
18	Wheel, Drive Side Blade	016284	1
19	Bushing, Modified 1 9/16" P1	087214	1
20	KEY, 9.5h7x9.5x3.8	087384	3

21	BOLT, UNC 1/4"x1 1/2"-8.8 ZINC DIN933 HEX HEAD	F05005-31	3	
22	WASHER, 1/4" UNC ZINC SPLIT LOCK	F81052-21	3	
23	SCREW, M8x8-33H ZINC HEX SOCKET SET FLAT POINT	F81014-1	3	
24	BELT, BLADE WHEEL B57	P04185-2	1	
25	BELT, 3BX72 DRIVE (D42)	014085	1	
	BELT, 3BX73 DRIVE (D38)	091548	1	
	BELT, 3BX74 DRIVE (E25HP 50HZ)	014249	1	
26	PULLEY, 3B5V124 SPECIAL DRIVE	087203-1	1	
27	WHEEL, BRAKE	087204-1	1	
28	STRAP, METAL-BACKED BRAKE	014391	1	
29	BOLT, M8X35-8.8 ZINC HEX HEAD FULL THREAD	F81002-13	6	
30	WASHER, 8.2 ZINC SPLIT LOCK	F81054-4	6	

3.2 Idle Blade Wheel Assembly

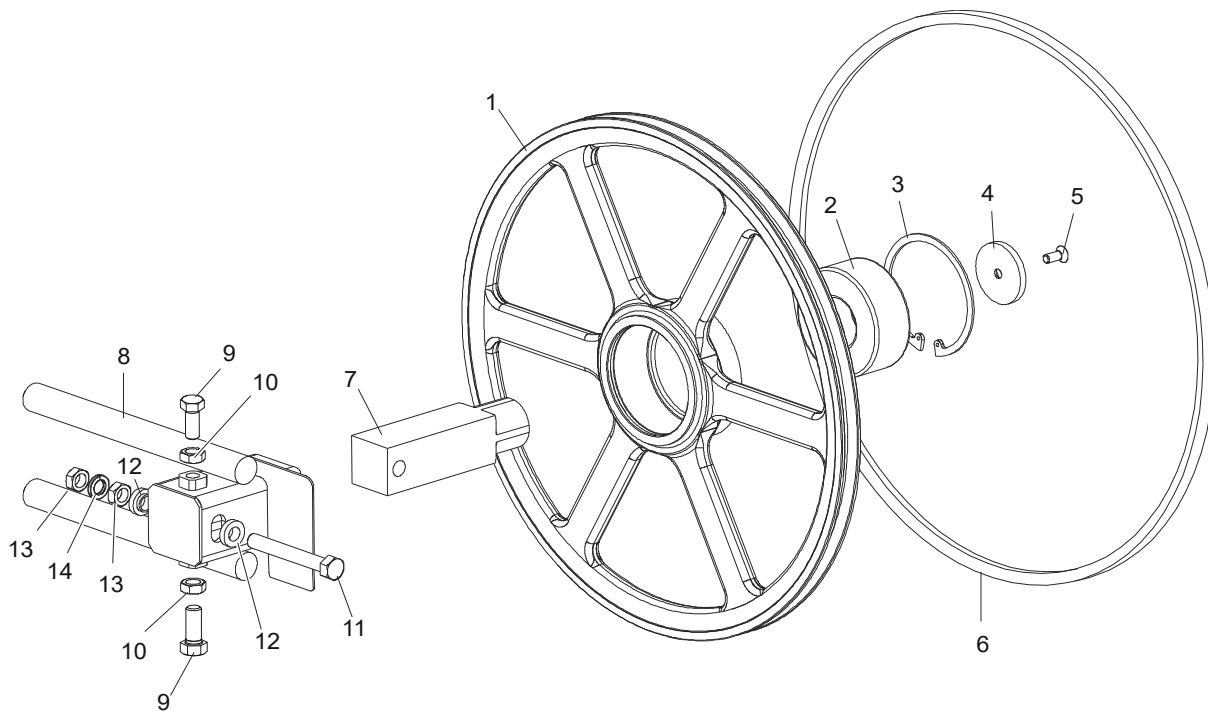

SM0241C

REF.	DESCRIPTION (◆ Indicates Parts Available In Assemblies Only)	PART #	QTY	
	WHEEL ASSEMBLY, IDLE SIDE BLADE	016120	1	
1	Wheel, Idle Side Blade	016013	1	◆
2	Bearing, Idle Side Blade Wheel 3309 B.2RSR TVH FAQ	086428	1	
3	Ring, 100mm Internal Retaining Beveled	F04254-28	1	
4	RETAINER, ZINC	095929-1	1	
5	SCREW, M10x25-10.9 DIN 7991 FLAT SOCKET HEAD CAP ZINC	F81003-82	1	
6	BELT, B57 BLADE WHEEL	P04185-2	1	
7	SHAFT, IDLE BLADE WHEEL	095732	1	
8	HOUSING, IDLE BLADE WHEEL SHAFT	087665	1	
9	BOLT, 1/2-20 X 1 1/2" HEX HEAD GRADE 5	F05008-53	2	
10	NUT, 1/2-20 HEX JAM	F05010-16	2	
11	BOLT, M12x1.25x100-8.8 HEX HEAD FULL THREAD ZINC	F81004-41	1	
12	SPACER, 1/2" I.D. FLANGED	086769-1	2	
13	NUT, M12x1.25 8.8 THIN ZINC	F81034-5	2	
14	WASHER, 12.2 SPLIT LOCK	F81056-2	1	

3 Blade Wheels & Tensioner

Blade Tensioner Guide Arms (LT40 Wide)

3.3 Blade Tensioner Guide Arms (LT40 Wide)

544239_001
544239_MANUAL

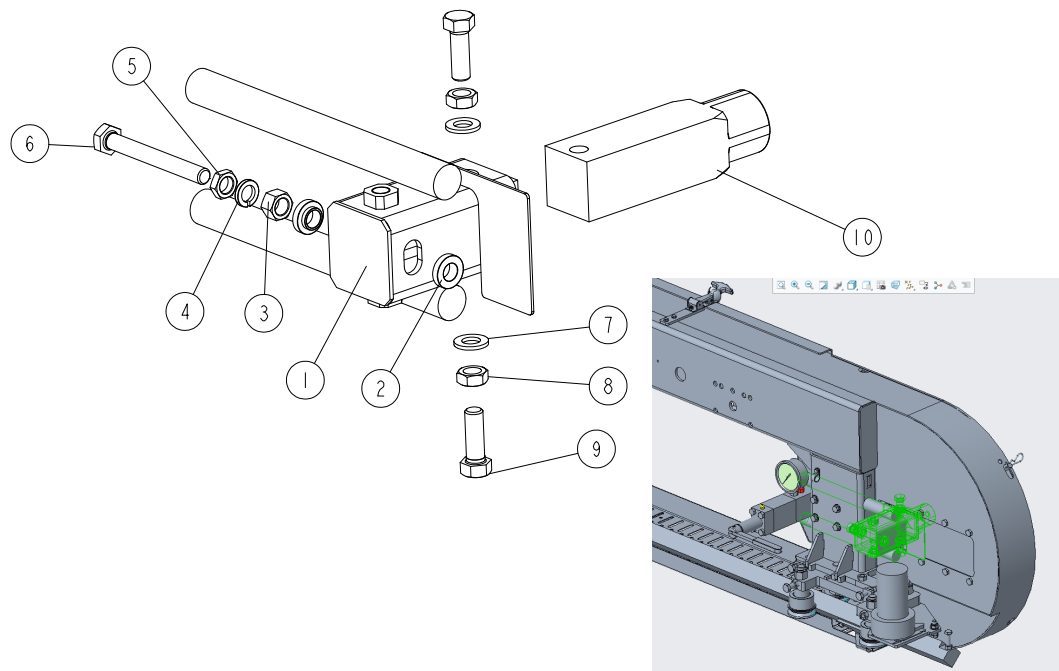

REF.	DESCRIPTION (* indicates parts available in assemblies only)	PART #	QTY
-	ARM ASSEMBLY, BLADE TENSIONER GUIDE	544239	1
1	ARM WELDMENT, BLADE TENSIONER GUIDE W/GUARD	087665-1	1
2	BUSHING, 12.8/23.8-8.6 16-3.3 ZINC-PLATED	086769-1	2
3	NUT, M12X1.25 - 8 - B HEX ZINC	F81034-8	1
4	WASHER, Z12.2 SPLIT LOCK ZINC	F81056-2	1
5	NUT, M12X1.25-8 THIN ZINC	F81034-5	1
6	BOLT, M12X1.25X100-8.8 HEX HEAD FULL THREAD ZINC	F81004-41	1
7	WASHER, 13 FLAT ZINC	F81056-1	2
8	NUT, 1/2-20 HEX JAM	F05010-16	2
9	BOLT, 1/2-20X1 1/2 HEX HEAD	F05008-53	2
10	SHAFT, IDLE SIDE BLADE WHEEL	095732	1

3.4 Hydraulic Blade Tensioner Assembly

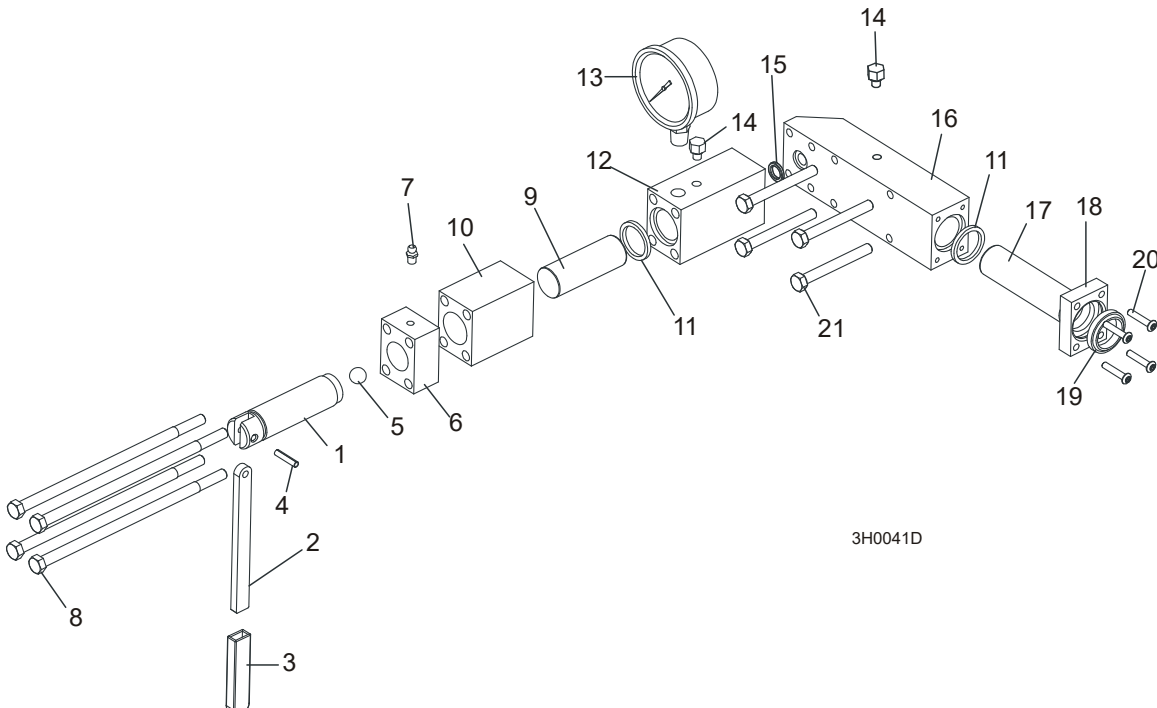

REF.	DESCRIPTION (◆ Indicates Parts Available In Assemblies Only)	PART #	QTY
	HYDRAULIC BLADE TENSIONER ASSEMBLY	532054	1
	Handle Assembly, Hydraulic Blade Tensioner Screw	A12294	1
1	Screw, Hydraulic Blade Tensioner	S10056	1
2	Handle, Hydraulic Tensioner Screw	095930-1	1
3	Sleeve, Plastic Handle	P08072	1
4	Pin, 3/16" x 7/8" Roll	F05012-11	1
5	Ball, 1/2" Steel	P02720	1
6	Block, Threaded Tensioner End	S10062	1
7	Fitting, 1/4-28 Grease	P05060	1
	Instruction Sheet, Tensioner Screw	A12294-518	1
8	Bolt, 5/16-18 X 7 1/2" Hex Head Grade 5	F05006-43	4
9	Piston, Hydraulic Tensioner Front 2 3/4" Long	S10060	1
10	Block, Piston Guide	S10061	1
11	Seal, 1" Diameter	P10051	2
12	Block, Hydraulic Tensioner Gauge Mounting	S10140	1
13	Gauge, 3000 PSI	090552	1
14	Plug, Hydraulic Tensioner Fill	P10065	2
15	Ring, 5/8" X 3/32" Square "O"	P10377	1
16	Block, Rear Tensioner Piston	S10142	1
17	Piston, Hydraulic Tensioner Rear 3 5/8" Long	S10059	1
18	Block, Rear Piston End	S10089	1
19	Wiper, 1" Diameter	P10053	1
20	Bolt, #10-24 X 1" Socket Button Head	F05004-43	4
21	Bolt, 5/16-18 X 2 3/4" Hex Head Grade 5	F05006-28	4
	Instruction Sheet, Hydraulic Tensioner Installation	A10136-272	1

SECTION 4 SAW HEAD

4.1 Middle Throat Screw

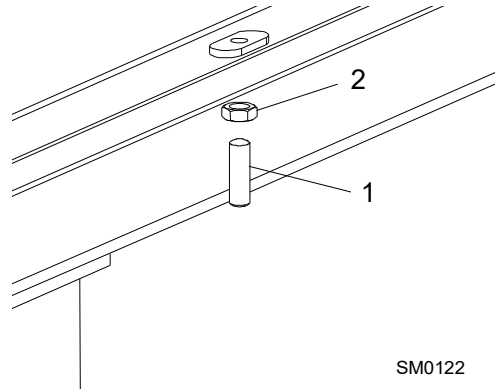

REF.	DESCRIPTION (◆ Indicates Parts Available In Assemblies Only)	PART #	QTY	
1	SCREW, M10X40-45H OVAL POINT SOCKET SET ZINC	F81003-61	1	
2	NUT, M10-8-B HEX ZINC	F81033-3	1	

4.2 Water Lube Solenoid Valve (not available in EC version)

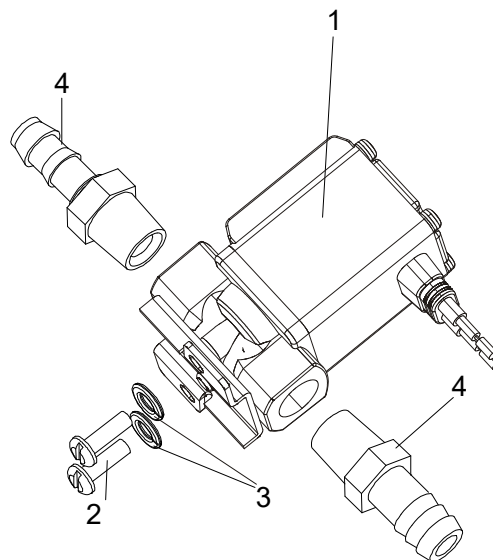

REF.	DESCRIPTION (◆ Indicates Parts Available In Assemblies Only)	PART #	QTY	
1	VALVE, WATER LUBE SOLENOID	509113	1	
2	SCREW, #10-32X1/2" CROSS SLOT ROUND HEAD	F05004-60	2	
3	WASHER, 5.1 SPLIT LOCK	F81052-2	2	
4	FITTING, 1/4" MALE NPT 3/8" HOSE BARB	P04682	2	

4.3 Clutch Lever Assembly

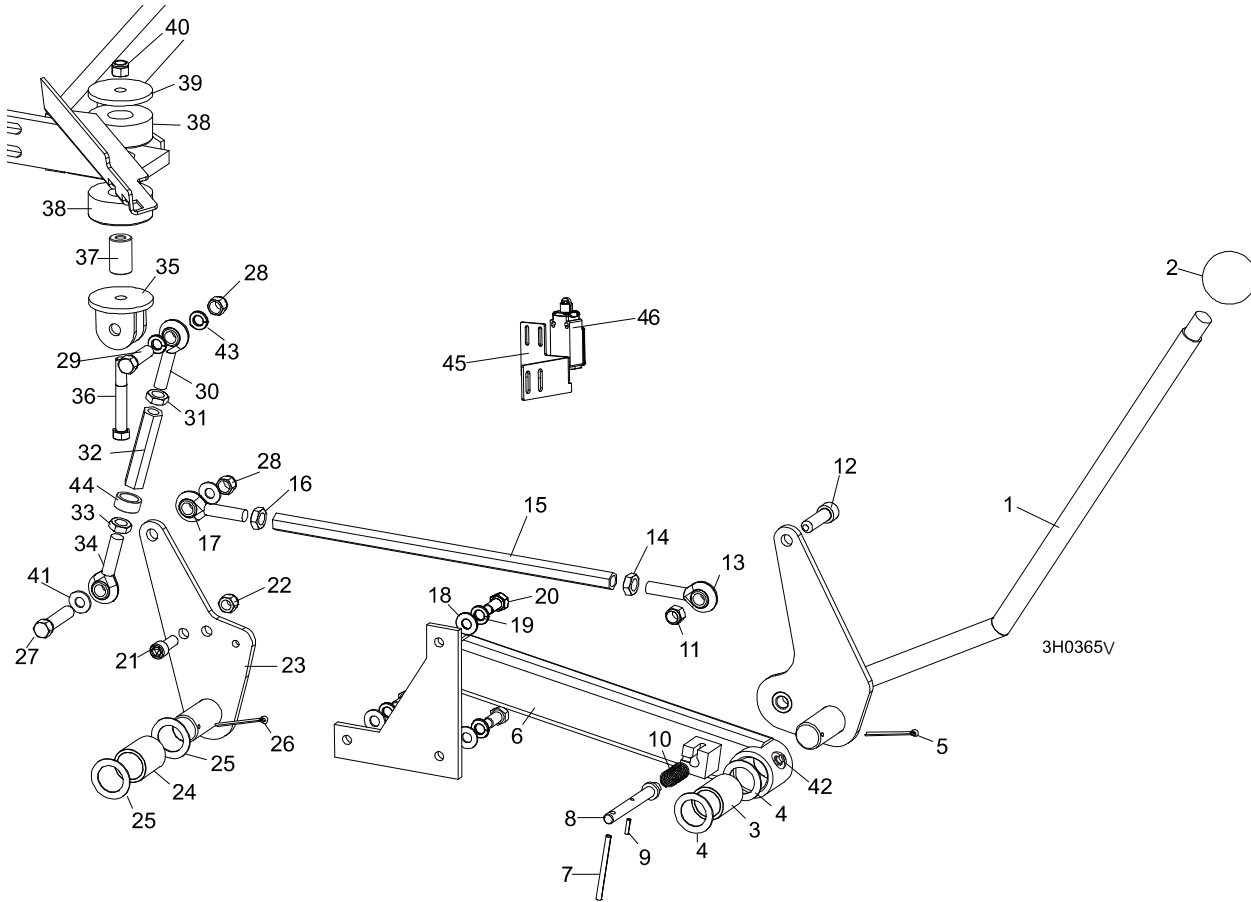

REF.	DESCRIPTION (◆ Indicates Parts Available In Assemblies Only)	PART #	QTY	
	HANDLE ASSEMBLY, EXTENDED CLUTCH/BRAKE	086242	1	
1	Lever, Clutch/Brake	086339-1	1	◆
2	Knob, Plastic Round	086337	1	
3	Bushing, Clutch/Brake Pivot	095349	1	
4	Washer, Clutch/Brake Pivot	087051-1	2	
5	Pin, 1/8" X 1 3/4" Cotter	F05012-43	1	
6	Extension Weldment, Clutch Handle	086244-1	1	
7	Pin, 3/16 x 2 1/2" Roll	F05012-27	1	
8	Pin, Clutch Detent	086243	1	◆
9	Pin, 1/8" x 3/4" Roll	F05012-6	1	
10	Spring, .58" OD x 1 1/8"	021243	1	
11	Nut ,M10-8-B Nylon Hex Zinc Lock	F81033-1	1	
12	Screw, M10x35 8.8 Hex Socket Head Cap Zinc	F81003-56	1	
13	Rod End, S10	094236	1	
14	Nut, M10 LH DIN 439 Thin Left	F81033-21	1	
15	Turnbuckle	518342-1	1	
16	Nut, 10mm x 1.25 Nylon	F81033-6	1	
17	End, Sal10 Rod Thread	096431	1	
18	WASHER, 8.4 SAE FLAT	F81054-1	3	
19	WASHER, 8.2 SPLIT LOCK	F81054-4	3	

4

Saw Head*Clutch Lever Assembly*

20	BOLT, M8X20-8.8-B HEX HEAD	F81002-4	3	
21	SCREW, M10 X 25 8.8 HEX SOCKET HEAD CAP ZINC	F81003-32	1	
22	NUT, M10-8-B HEX NYLON LOCK	F81033-1	1	
23	PLATE WELDMENT, CLUTCH PIVOT	087086-1	1	
24	BUSHING, CLUTCH/BRAKE PIVOT	095349	1	
25	WASHER, CLUTCH/BRAKE PIVOT	087051-1	2	
26	PIN, 1/8" X 1 3/4" COTTER	F05012-43	1	
27	BOLT, M10X50-8.8 HEX HEAD FULL THREAD ZINC	F81003-4	1	
28	NUT, M10-8-B NYLON HEX ZINC LOCK	f81033-1	2	
29	BOLT, M10X45-8.8 HEX HEAD FULL THREAD ZINC	F81003-3	1	
	TURNBUCKLE ASSEMBLY, CLUTCH/BRAKE LEVER	518339	1	
30	End, SAL10 Rod Thread	096431	1	
31	Nut, 10mm x 1.25 Nylon	F81033-6	1	
32	Turnbuckle	518243-1	1	
33	Nut, M10 LH DIN 439 Thin Left	F81033-21	1	
34	Rod End, SA10	094236	1	
35	BRACKET, CLUTCH MOUNT	W12411-1	1	
36	BOLT, M10X70-8.8 HEX HEAD ZINC	F81003-20	1	
37	SPACER, MOTOR MOUNT VIBRATION BUSHING	506712	1	
38	BUSHING, MOTOR MOUNT VIBRATION	P05032	2	
39	WASHER, 3/8" I.D. X 2 1/4" O.D. X 3/16" THICK	S12412-0	1	
40	NUT, 3/8-16 NYLON LOCK	F05010-10	1	
41	WASHER, 10.5 FLAT ZINC	F81055-1	2	
42	FITTING, M6 GREASE	086280	1	
43	WASHER, 10.2 SPLIT LOCK ZINC	F81055-2	2	
44	BUSHING 16/22-10 ZINC (only with KOHLER G38 engines)	546569-1	1	
45	ANGLE, LIMIT SWITCH - D25	557104-1	1	
46	LIMIT SWITCH GLCB01C - D25	100910	1	

4.4 Brake Assembly

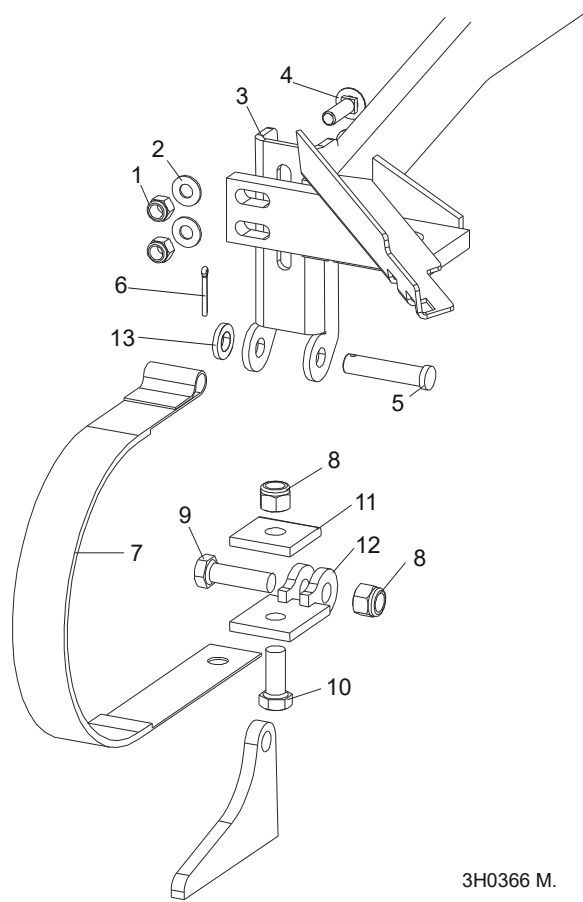

3H0366 M.

REF.	DESCRIPTION (◆ Indicates Parts Available In Assemblies Only)	PART #	QTY
	STRAP RETROFIT, SUPER BRAKE	014441	1
1	Nut, 3/8-16 Nylon Lock	F05010-10	2
2	Washer, 10.5 Flat	F81055-1	2
3	Bracket, Upper Super Brake Strap Mount	014395	1
4	Bolt, 3/8-16 x 1 1/4" Carriage Head Grade 5	F05007-127	2
5	Pin, 1/2" x 2 1/4" Clevis	F05012-81	1
6	Pin, 1/8" x 1" Cotter	F05012-1	1
7	Strap, Upper Pivot Metal Brake	014391	1
8	Nut, M12-8-B Nylon Lock	F81034-2	2
9	Bolt, M12 x 40-8.8 Hex Head	F81004-4	1
10	Bolt, M12 x 30-8.8 Hex Head	F81004-22	1
11	Washer, Brake Strap Clamp	090063-1	1
12	Bracket Weldment, Brake Lower Pivot Painted	092200-1	1
13	Washer, 13 Flat Zinc	F81056-1	1

4.5 Board Return Assembly

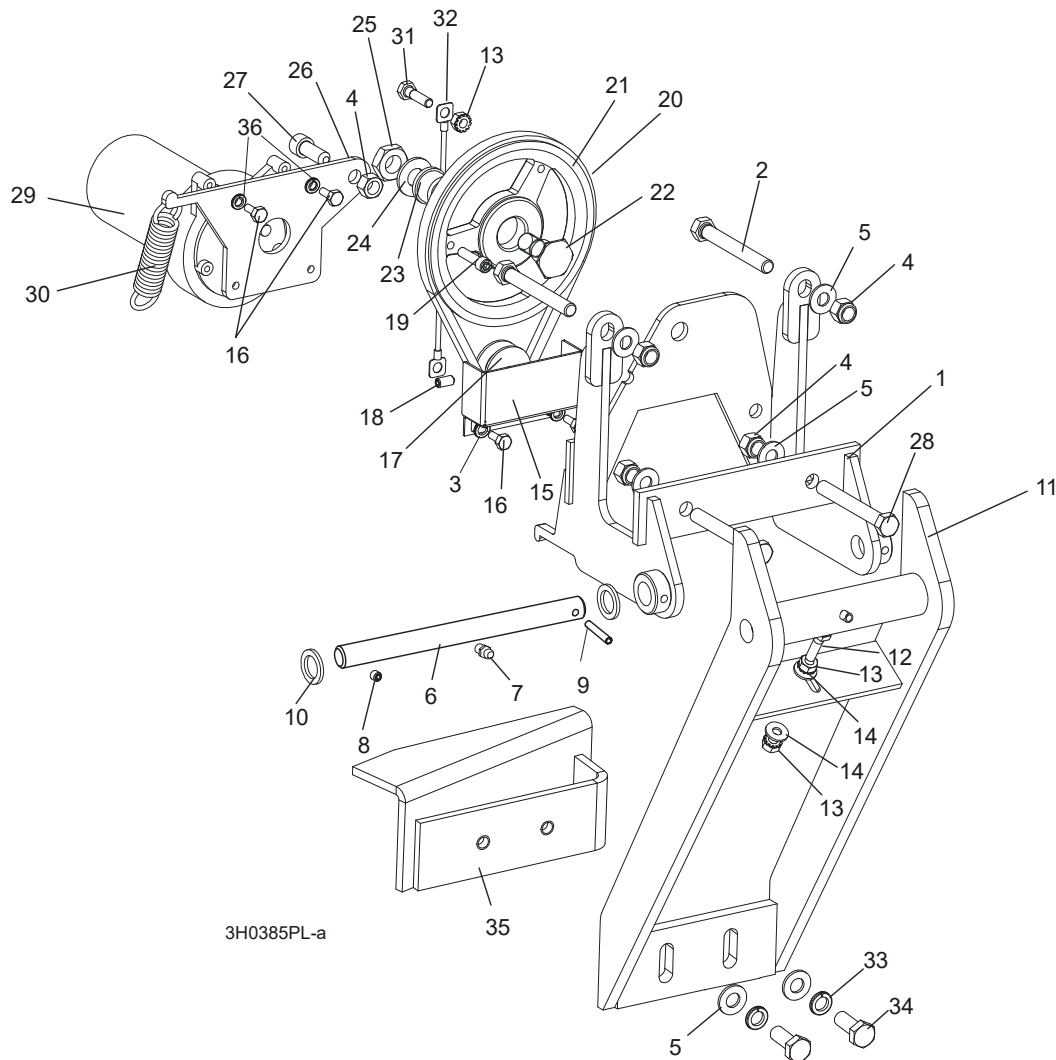

REF.	DESCRIPTION (◆ Indicates Parts Available In Assemblies Only)	PART #	QTY
	RETURN ASSEMBLY, BOARD	087839	1
1	Mount Weldment, Board Return	087788-1	1
2	Screw, M10x70-8.8 Hex Socket Head Cap Zinc	F81003-60	2
3	Washer, 5.3 Flat Zinc	F81052-1	2
4	Nut, M10-8-B Nylon Hex Zinc Lock	F81033-1	5
5	Washer, 10.5 Flat	F81055-1	6
6	Pin Kit, Board Return Replacement Pivot	087837	1
7	Fitting, M6 Grease	086280	1
8	Screw, M6 X 8 Black Oxide Socket Head Set Cup Point	F81013-1	1
9	Pin, 5 X 30 Roll	F81044-21	1
10	Washer, 5/8" x 15/16" x .094 Nylon	F05011-19	2
11	Arm Weldment, Board Return	087838-1	1
12	Screw, 1/4-20 x 3/4" Full Thread Hex Head Cap	F05005-101	1

13	Nut, 1/4-20 Self-Locking	F05010-9	3	
14	Washer, 7.4 Flat	F81056-11	2	
15	Guard, Board Return Belt	087985-1	1	
16	Screw, 10-32 x 1/2" Hex Head Machine	F05004-60	4	
17	Sheave, 1.42 x .32	015074	1	
18	Screw, 1/4-20 Socket Head Set Cup Point Nylon	F05005-55	1	
19	Screw, 1/4-20 x 1" Socket Head Cap	F05005-89	1	
20	Belt, 3L190	015477	1	
21	Sheave, OK50 x 1/2" Modified	015224	1	
22	Bolt, Idler Pulley Pivot	015221	1	
23	Bushing, 5/8" x 7/8" x 1/2" Bronze	P05135	1	
24	Washer, 13 Flat	F81056-1	1	
25	Nut, 1/2-20 Jam Nylon Lock	F05010-79	1	
26	Plate, Motor Pivot	087871	1	
27	Screw, M10 x 25-8.8 Black Oxide Socket Head Cap	F81003-32	1	
28	Bolt, M10x75-8.8-Hex Head Zinc	F81003-15	2	
29	Motor, Current Applications 1/30HP 12VDC Gear	079214	1	
30	Spring, 3/4" x 2 7/8" x 12 Gauge	015479	1	
31	Bolt, 1/4-20 x 1" Hex Head Grade 5	F05005-101	1	
32	Cable, Board Return	016090	1	
33	Washer, 10.2 Split	F81055-2	2	
34	Bolt, 3/8-16 x 3/4" Hex Head	F81003-1	2	
35	Angle, Board Return	087835-1	1	
36	Washer, 5.1 Split Lock Zinc	F81052-2	2	

4.6 Water Lube Assembly

550787_005_LT40_DH
550787_MANUAL

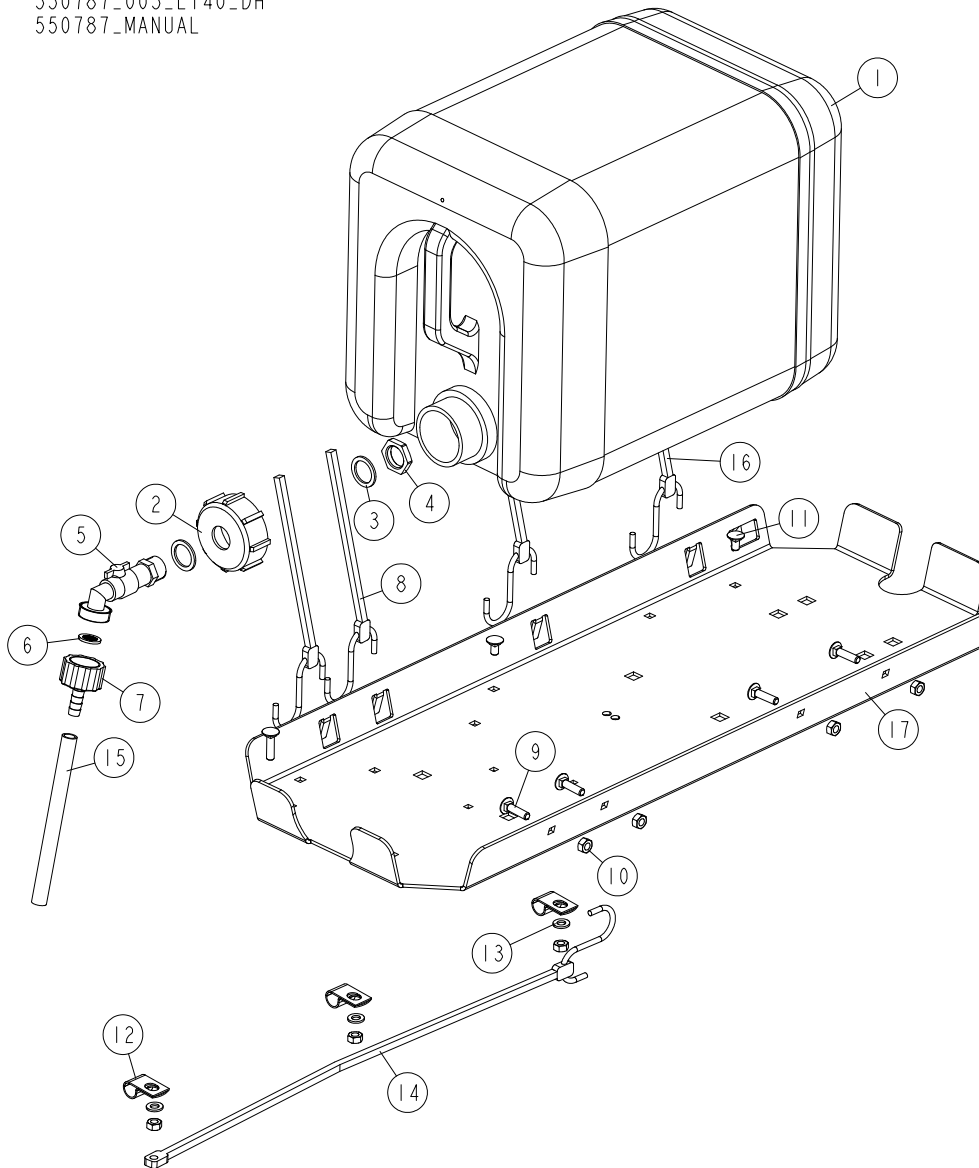

REF	DESCRIPTION (u indicates parts available in assemblies only)	PART #	QTY
-	TANK, OIL	550787	1
1	BOTTLE, WATER	513866	1
2	NUT, BOTTLE	550785	1
3	SEAL, 27X20X1.5 ESSENTRA 467673 RUBBER	550780	2
4	NUT, 1/2 ESSENTRA 467615 GLAND	550779	1
5	FITTING, WATER LUBE SHUTOFF VALVE	550776	1
6	FILTER, WATER LUBE	550778	1
7	FITTING, G3/4" X 10MM HOSE BARB	550777	1
8	STRAP, 20" RUBBER W/HOOK	P11668	2
9	BOLT, 1/4-20 X 1" CARRIAGE HEAD	F05005-34	5
10	NUT, 1/4-20 LOCK	F05010-21	7

REF	DESCRIPTION (u indicates parts available in assemblies only)	PART #	QTY	
11	BOLT, 1/4-20 X 1/2" CARRIAGE HEAD	F05005-33	2	
12	CLAMP, 1/2" EMT COATED	P07584	3	
13	WASHER, 7.4 FLAT	F81056-11	3	
14	STRAP, 15 RUBBER W/S HOOKS	P07461	1	
15	TUBING, WATER LUBE 3/8" I.D.	R01885	1	
16	STRAP, 24" RUBBER (FOR FUEL TANK - SEE E	P11258	2	
17	TRAY, FUEL TANK/WATER BOTTLE	099600-1	1	

4.7 LT40DC Saw Head Decals

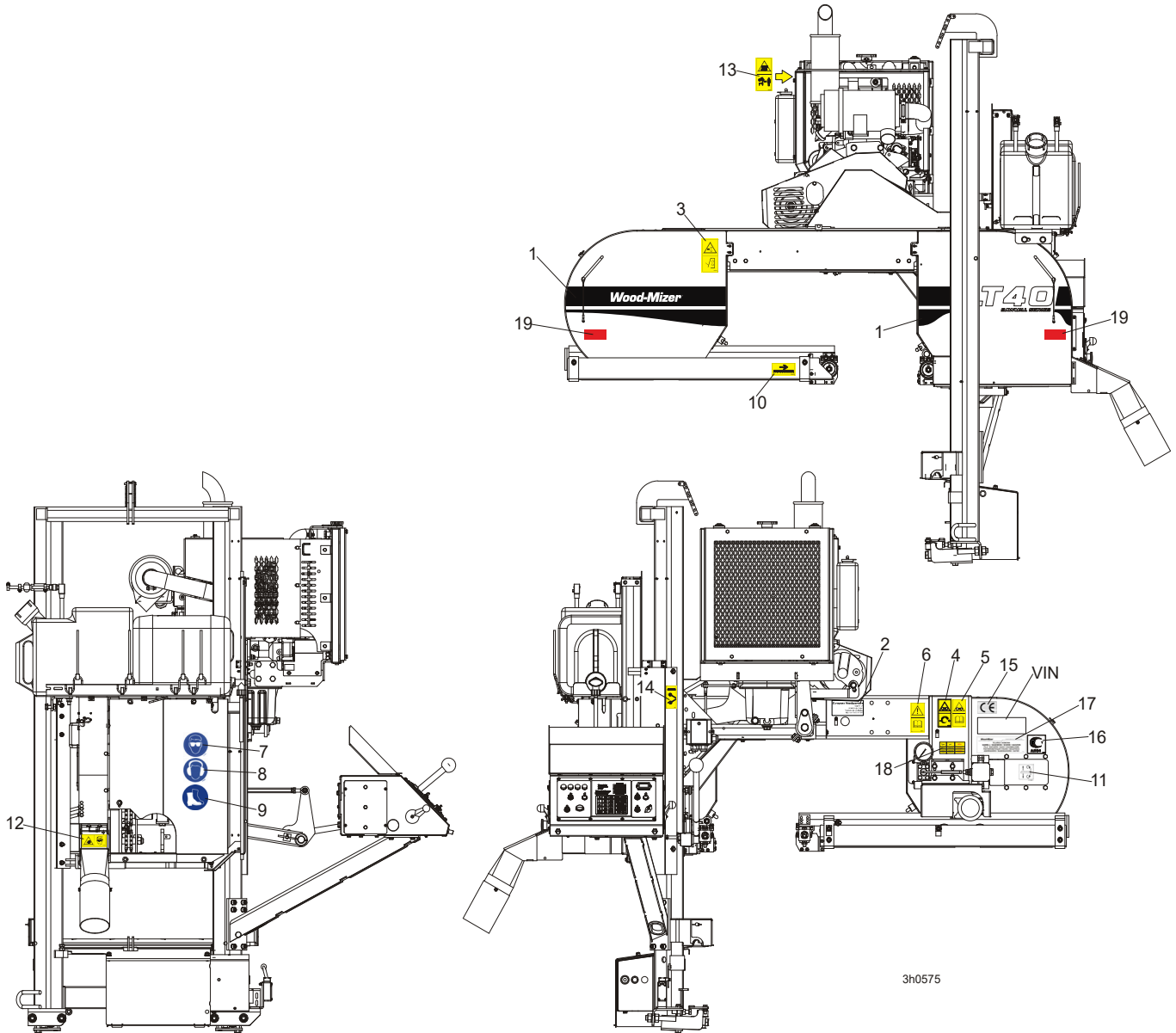

3h0575

REF.	DESCRIPTION (◆ Indicates Parts Available in Assemblies Only)	PART #	QTY
1	DECAL, LT40 SERIES SAWMILL	092763	1
	PICTOGRAPHIC DECAL KIT, LT40DC	099517	1
2	DECAL, EUROPEAN HEADQUARTERS ADDRESS	015841	1
3	DECAL, SAWMILL COVERS CAUTION	099220	2
4	DECAL, BLADE TENSION (PICTOGRAM)	099219	1
5	DECAL, BLADE TENSION - INSTRUCTIONS (PICTOGRAM)	099223	1
6	DECAL, READ OPERATOR'S MANUAL (PICTOGRAM)	096317	1
7	DECAL, EYE PROTECTION WARNING (PICTOGRAM)	S12004G	1
8	DECAL, EAR PROTECTION WARNING (PICTOGRAM)	S12005G	1
9	DECAL, USE SAFETY BOOTS (PICTOGRAM)	501465	1
10	DECAL, BLADE MOVEMENT DIRECTION (PICTOGRAM)	096321	1
11	DECAL, BLADE ALIGNMENT	P11789	1

12	DECAL, SAWDUST CHUTE WARNING (PICTOGRAM)	099222	1	
13	DECAL, KEEP AWAY - HOT PARTS (PICTOGRAM)	086099	1	
14	DECAL, BLADE DRIVE WARNING (PICTOGRAM)	096315	1	
15	DECAL, CE CERTIFIED SAWMILL (SMALL)	P85070	2	
16	DECAL, RUSSIAN SAFETY CERTIFICATION	099401	1	
17	DECAL, INTERNATIONAL SAWMILL NAME	501466	1	
18	DECAL, BLADE SETTING	P85066	1	
	DECAL, KEEP AWAY DANGER, PICTOGRAM	099221	1	
	DECAL, MAX. OIL PRESSURE, PICTOGRAM	099524	1	
19	REFLECTOR, 2 DIA RED (MOBILE SAWMILLS ONLY)	521701	2	

4.8 Blade Housing Covers

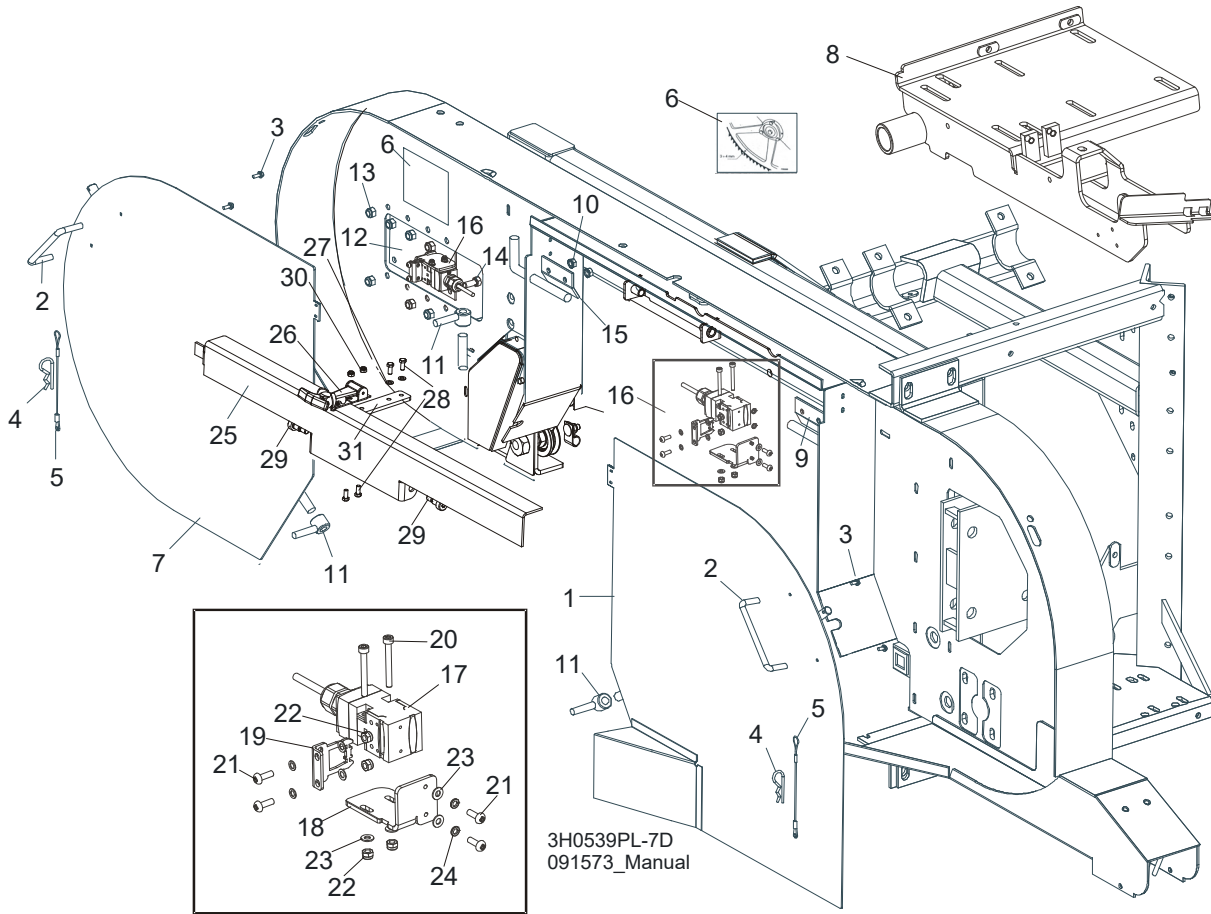

REF.	DESCRIPTION (◆ Indicates Parts Available In Assemblies Only)	PART #	QTY
	COVER ASSEMBLY, DRIVE SIDE BLADE HOUSING WITH HANDLE	087165	1
1	Cover Weldment, Drive Side Blade Housing	087159-1	1 ◆
2	Handle, Blade Housing Cover	P08065	1
3	Screw, #8-32 x 3/8"	F05015-8	2
	Pin Assembly, Cover Retainer	A11881	1
4	Pin, Safety Retainer	N/A	1
5	Cable, 3/64" x 6" Lanyard	N/A	1
6	DECAL, BLADE SETTING	P85066	1
	COVER, IDLE SIDE BLADE HOUSING WITH HANDLE	086431	1
7	Cover, Idle Side Blade Housing	086430-1	1 ◆
2	Handle, Blade Housing Cover	P08065	1
3	Screw, #8-32 X 3/8" Self-Tapping	F05015-8	2
	Pin Assembly, Cover Retainer	A11881	1
4	Pin, Safety Retainer	N/A	1
5	Cable, 3/64" x 6" Lanyard	N/A	1
8	MOUNT WELDMENT E15/E20/E25	087736-1 ¹	1
9	HINGE, MIDDLE BLADE HOUSING COVER	S07522	1
10	NUT, 1/4-20 SELF-LOCKING HEX	F05010-9	4
11	NUT, COVER TURN	086365-1	2

12	PLATE, IDLE BLADE WHEEL GUARD	086230	1	
13	NUT, 5/16-18 HEX NYLON LOCK	F05010-58	6	
14	BOLT, 5/16-18 X 3/4" HEX HEAD GRADE 2	F05006-5	6	
15	HINGE, MIDDLE BLADE HOUSING COVER	085336-1	1	
16	SWITCH ASSEMBLY, SAFETY SHUT-OFF	094301	2	
17	Switch, AZ17-11ZRK Safety	094232	2	
18	Bracket, Safety Switch Mount Painted	094300-1	2	
19	Key, AZ17/170-B5 Safety Switch	094422	2	
20	Screw, M4 x 35-8.8 Hex Socket Head Cap Zinc	F81011-34	4	
21	Screw, M4 x 12-8.8 Hex Socket Head Cap zinc	F81011-43	8	
22	Nut, M4-B Hex Nylon Zinc Lock	F81029-1	8	
23	Washer, Z4.1 Split Lock	F81051-1	4	
24	Washer, 4.3 Flat Zinc	F81051-2	8	
	BLADE FLAP ASSEMBLY	511645²	1	
25	Cover, LT40 Blade	511116-1	1	
26	Latch, Flexible Draw	014829	1	
27	Washer, 5.3 Flat Zinc	F81052-1	2	
28	Bolt, M5 X 12-5.8-Hex Head Full Thread Zinc	F81000-5	4	
29	Bolt, 10/M8 X 12-12.9 ISO-7379	F81003-62	2	
30	Nut, M5-8-Fe/Zn5 DIN985	F81030-2	2	
31	Plate, LT40 Blade Cover	512570-1	1	

¹ Only LT40 AC Sawmills

² Belongs to 091573

4 Saw Head

Drive Belt Covers

4.9 Drive Belt Covers

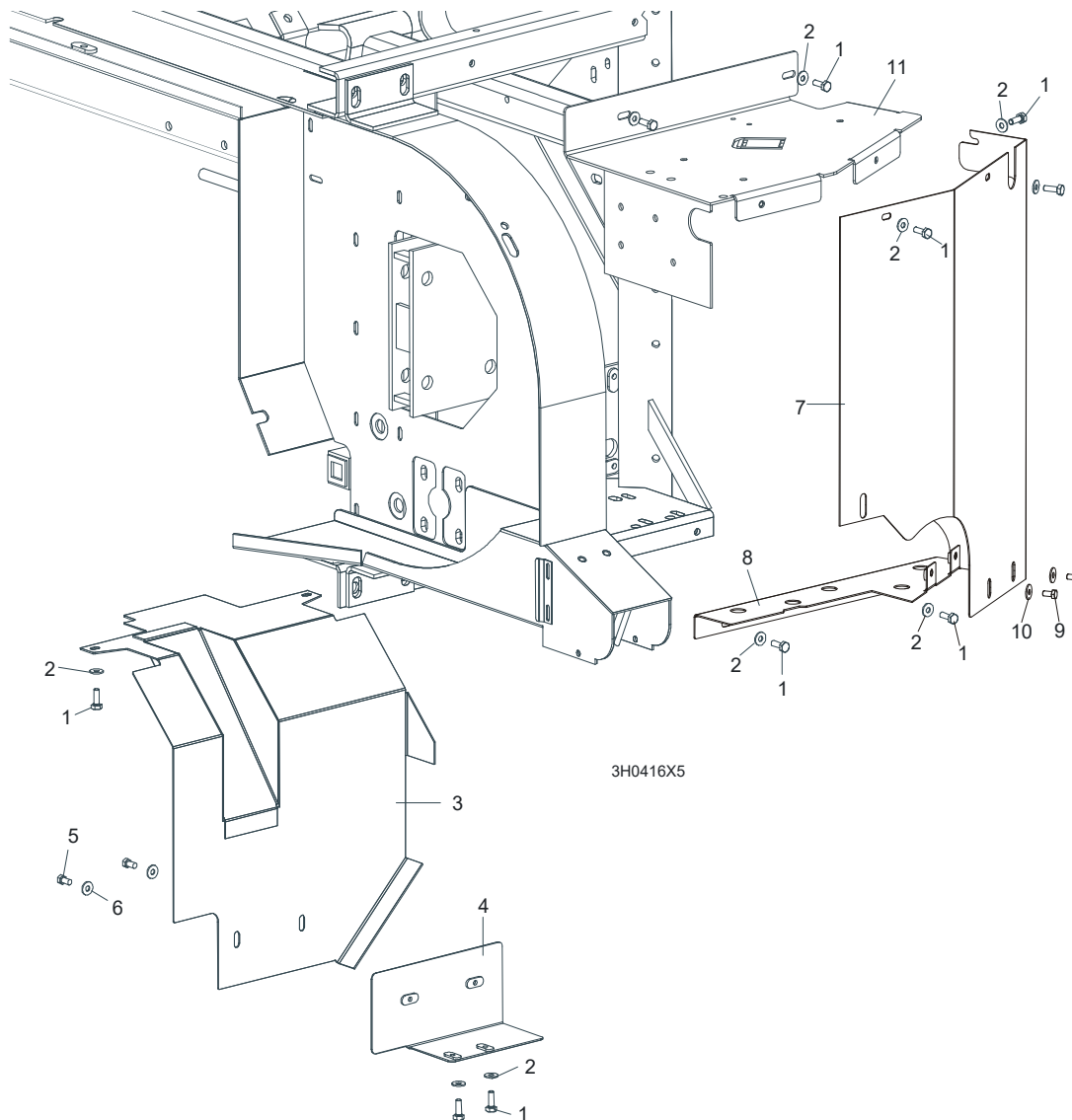

REF.	DESCRIPTION (◆ Indicates Parts Available In Assemblies Only)	PART #	QTY
1	BOLT, M6X12-8.8 ZINC	F81001-7	11
2	WASHER 6.5 ZINC	F81053-11	11
	GUARD ASSEMBLY, CLUTCH LEVER	086290	1
3	Guard Weldment, Manual Clutch	093398-1	1
4	Mount Weldment, Clutch Guard	086275-1	1
5	Bolt, M6X12-8.8 Hex Head Zinc	F81001-7	2
6	Washer, 6.5 Flat Zinc	F81053-11	2
	GUARD ASSEMBLY, DRIVE PULLEY SIDE	093396	1
7	Guard Weldment, Side Up/Down	100474-1	1
8	Guard Weldment, Saw Head Frame Lower	100473-1	1
9	Bolt, M6X12-8.8 Hex Head Zinc	F81001-7	2
10	Washer, 6.5 Flat Zinc	F81053-11	2
11	GUARD, DRIVE PULLEY TOP	087033-1	1

4.10 Sawdust Chute

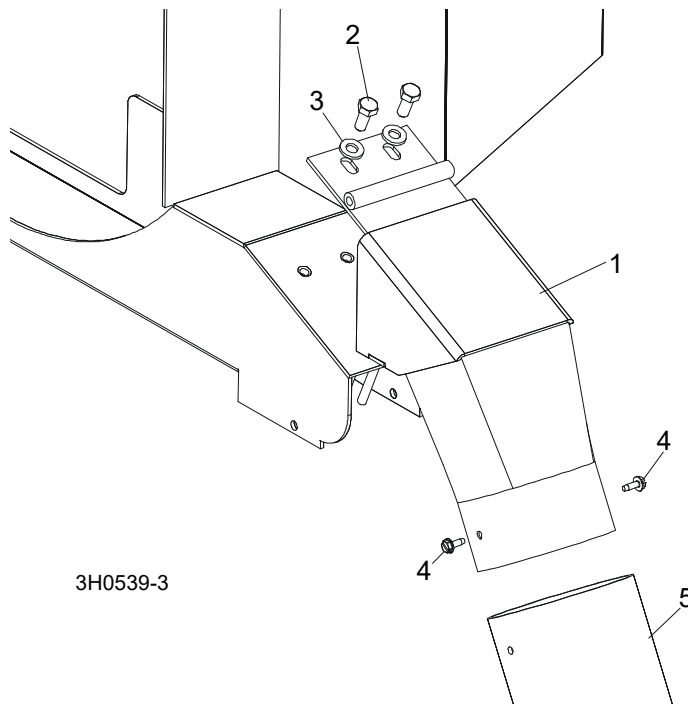

REF.	DESCRIPTION (◆ Indicates Parts Available In Assemblies Only)	PART #	QTY	
1	CHUTE, LT40 SAWDUST	100903-1	1	
2	BOLT, M8X20-8.8-B-ZINC HEX HEAD	F81002-20	2	
3	WASHER 8.4 FLAT ZINC	F81054-1	2	
4	BOLT, #10-24 X 1/2" SELF-TAPPING	F05015-7	2	
5	TUBING, 4" I.D. RUBBER	086364	0.6 m	
	STRAP, 20" RUBBER W/HOOK	P11668	1	
	BOLT, 1/4-20 X 1 1/4" HEX HEAD FULL THREAD	F05005-3	1	
	WASHER, 7.4 FLAT	F81056-11	1	
	NUT, 1/4-20 LOCK	F05010-21	1	

4.11 Saw Head Pin

522948_001
522948_MANUAL

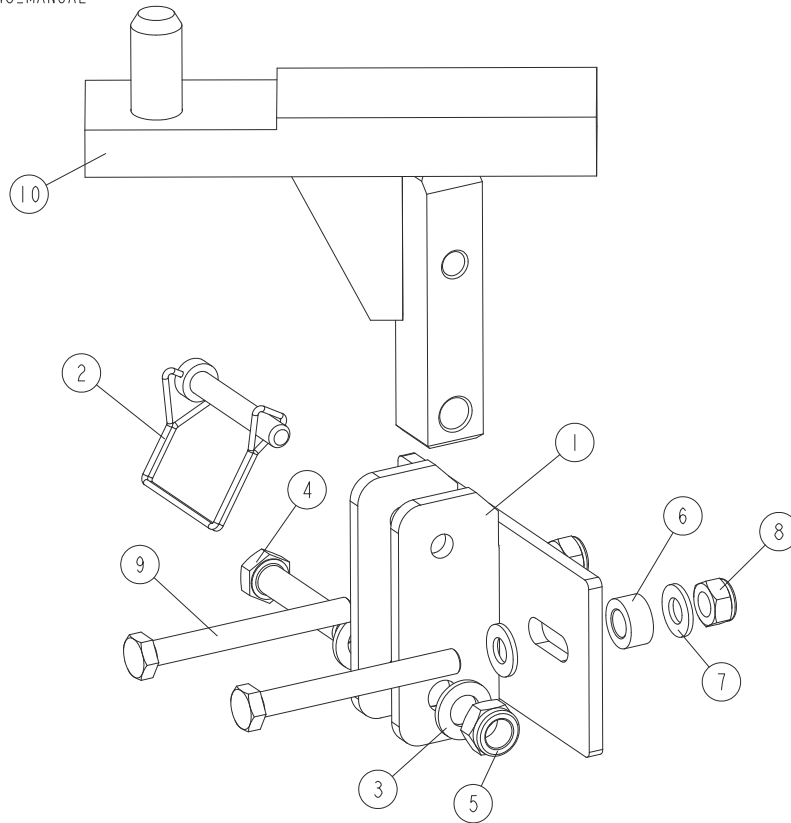

REF.	DESCRIPTION (◆ Indicates Parts Available In Assemblies Only)	PART #	QTY
-	SAW HEAD PIN, LT40M - COMPLETE	522948	1
1	BRACKET, LT40 SAW HEAD REST	522947-1	1
2	PIN, 3/8X2 1/4 SNAP	014151	1
3	WASHER, 13 FLAT ZINC	F81056-1	2
4	BOLT, M12X60-8.8-HEX HEAD ZINC	F81004-5	1
5	NUT, M12 8 HEX NYLON ZINC LOCK	F81034-2	1
6	BUSHING, 11/20-10 ZINC	090936-1	1
7	WASHER, 10.5 FLAT ZINC	F81055-1	4
8	NUT, M10 HEX NYLON ZINC LOCK	F81033-1	2
9	BOLT, M10X90-8.8-B-HEX HEAD ZINC	F81003-66	2
10	PIN WELDMENT, LT70 S/M SAW HEAD REST	094658-1	1

4.12 Saw Head Rest Bracket. Plate Mount.

LT70ME20SAH3-WSWR_001
 LT70ME20SAH3-WSWR_MANUAL

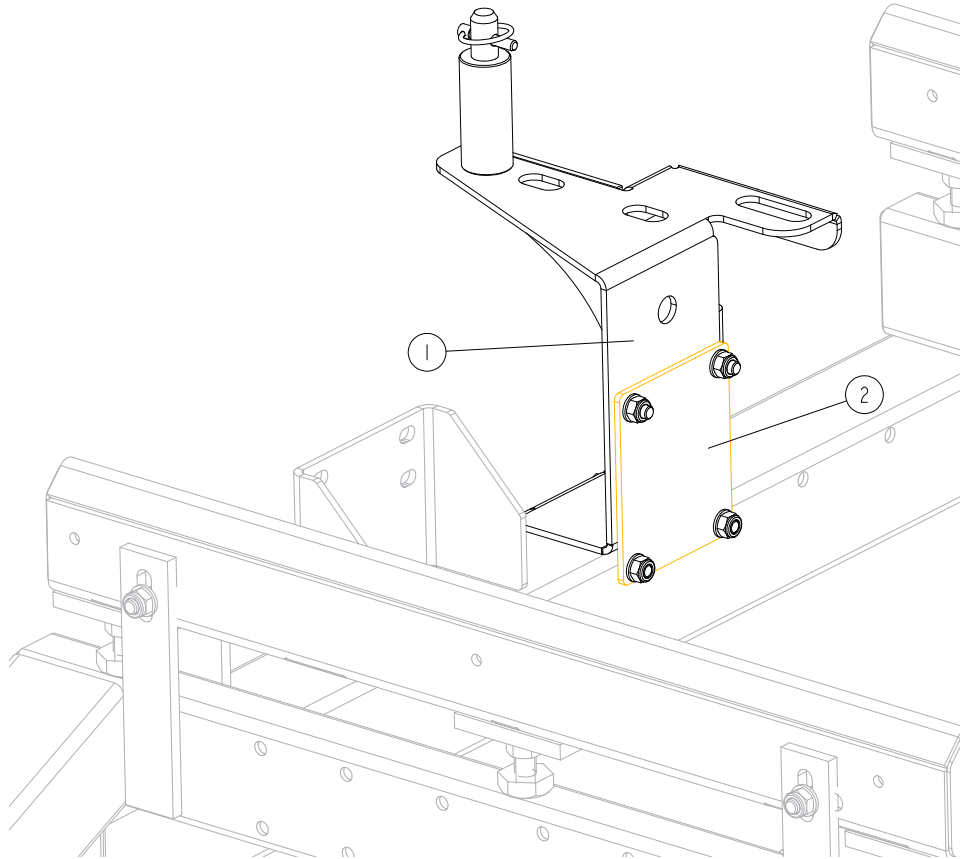

RE.	DESCRIPTION (◆ Indicates Parts Available In Assemblies Only)	PART #	QTY	
1	BRACKET, LT SAWMILL SAW HEAD REST See Section 4.13	546306	1	
2	PLATE, MOUNT	087055-1	1	

4

Saw Head

LT20/40 Saw Head Rest Bracket

4.13 LT20/40 Saw Head Rest Bracket

546306_001
546306_MANUAL

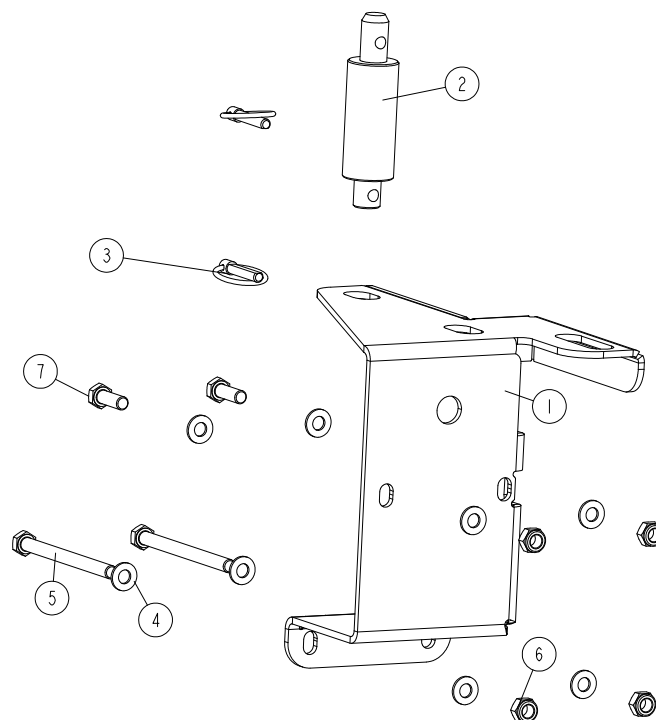

REF.	DESCRIPTION (◆ Indicates Parts Available in Assemblies Only)	PART #	QTY
-	BRACKET, SAW HEAD REST (LT SAWMILLS)	546306	1
1	PLATE, SAW HEAD REST BRACKET	546307-1	1
2	PIN, LT20 SAW HEAD REST BRACKET	097935-1	1
3	PIN, 8 BN914 (BOSSARD 1364650) LINCH	F81046-2	2
4	WASHER, 10.5 FLAT ZINC	F81055-1	8
5	BOLT, M10X125 8.8 HEX HEAD ZINC	F81003-18	2
6	NUT, M10-8-B HEX NYLON ZINC LOCK	F81033-1	4
7	BOLT, M10X30-8.8 HEX HEAD FULL THREAD ZINC	F81003-2	2

4.14 Saw Head Support Bracket (New M-type Frame, Mobile Sawmills)

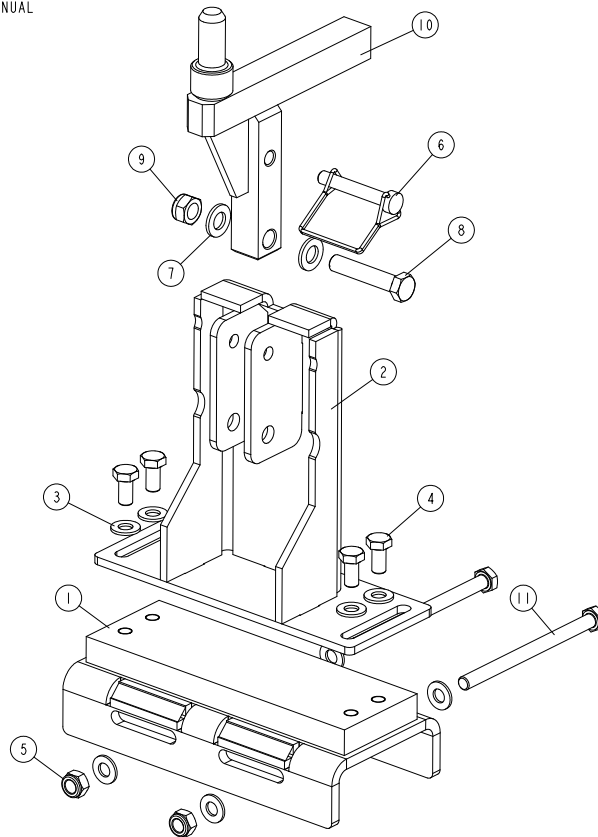
555184_001
555184_MANUAL

REF.	DESCRIPTION (◆ Indicates Parts Available In Assemblies Only)	PART #	QTY
-	BRACKET, LT40 SAW HEAD SUPPORT ("M" FRAMES)	555184	1
1	BASE, LT20/40/70 SAW HEAD SUPPORT BRACKET	545600-1	1
2	MOUNT WELDMENT, LT20/40/70 SAW HEAD REST PIN	545618-1	1
3	WASHER, 10.5 FLAT ZINC	F81055-1	8
4	BOLT, ISO 4017-M10X20-8.8-A2E HEX HEAD	F81003-53	4
5	NUT, M10-8-B HEX NYLON ZINC LOCK	F81033-1	2
6	PIN, 3/8X2 1/4 SNAP	014151	1
7	WASHER, 13 FLAT ZINC	F81056-1	2
8	BOLT, M12X60-8.8 HEX HEAD ZINC	F81004-5	1
9	NUT, M12 8 HEX NYLON ZINC LOCK	F81034-2	1
10	PIN WELDMENT, LT40 WIDE SAW HEAD REST	545664-1	1
11	BOLT, M10X140-8.8 HEX HEAD ZINC	F81003-5	2

4.15 Saw Head Rest Assembly, LT40M - 2.2

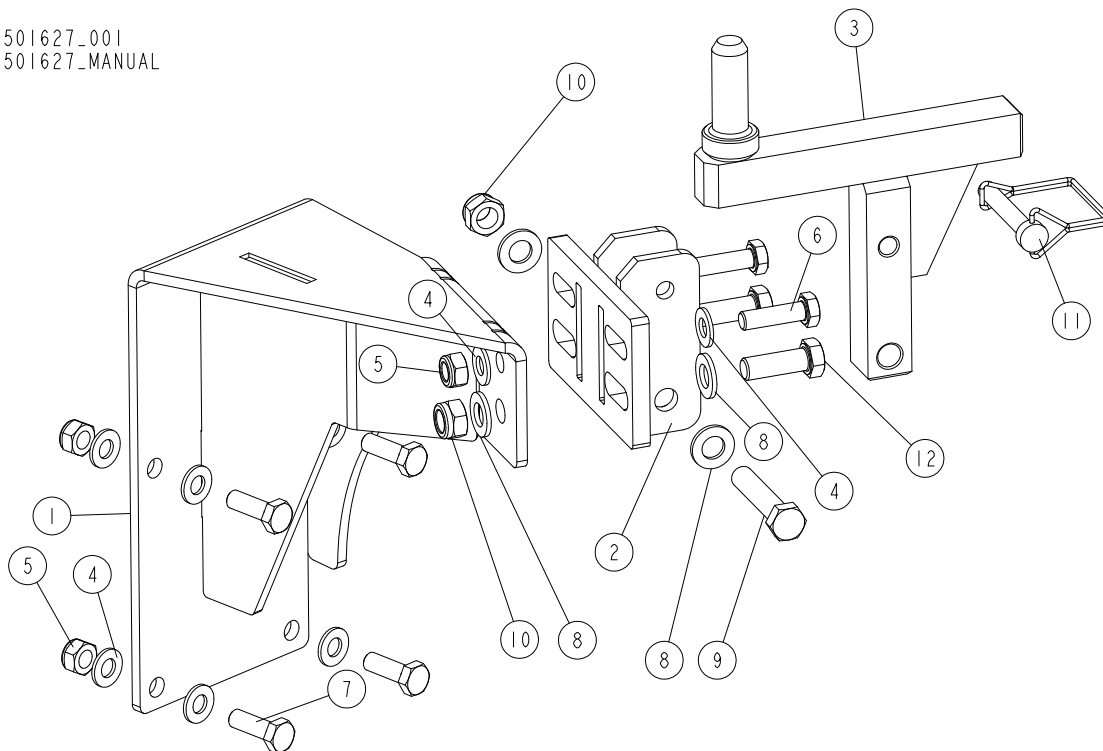
501627_001
501627_MANUAL

REF.	DESCRIPTION (* indicates parts available in assemblies only)	PART #	QTY
-	REST ASSEMBLY, LT40ME15SAH3-1.8 (WFL) SAW HEAD	501627	1
1	BRACKET WELDMENT, VERTICAL	501837-1	1
2	BRACKET, LT40 SAW HEAD REST PIN MOUNT	092765-1	1
3	PIN WELDMENT, LT50 SAW HEAD REST	090421-1	1
4	WASHER, 10.5 FLAT ZINC	F81055-1	12
5	NUT, M10-8-B HEX NYLON ZINC LOCK	F81033-1	6
6	BOLT, M10X35 8.8 HEX HEAD FULL THREAD ZINC	F81003-17	2
7	BOLT, M10X30-8.8 HEX HEAD FULL THREAD ZINC	F81003-2	4
8	WASHER, 13 FLAT ZINC	F81056-1	6
9	BOLT, M12X60-8.8 HEX HEAD ZINC	F81004-5	1
10	NUT, M12-8 DIN 982 HEX NYLON ZINC LOCK	F81034-2	3
11	PIN, 3/8X2 1/4 SNAP	014151	1
12	BOLT, M12X35 8.8 HEX HEAD FULL THREAD ZINC	F81004-24	2

4.16 LT40 Wide Saw Head Parts

532192-1_001
 532192-1_MANUAL

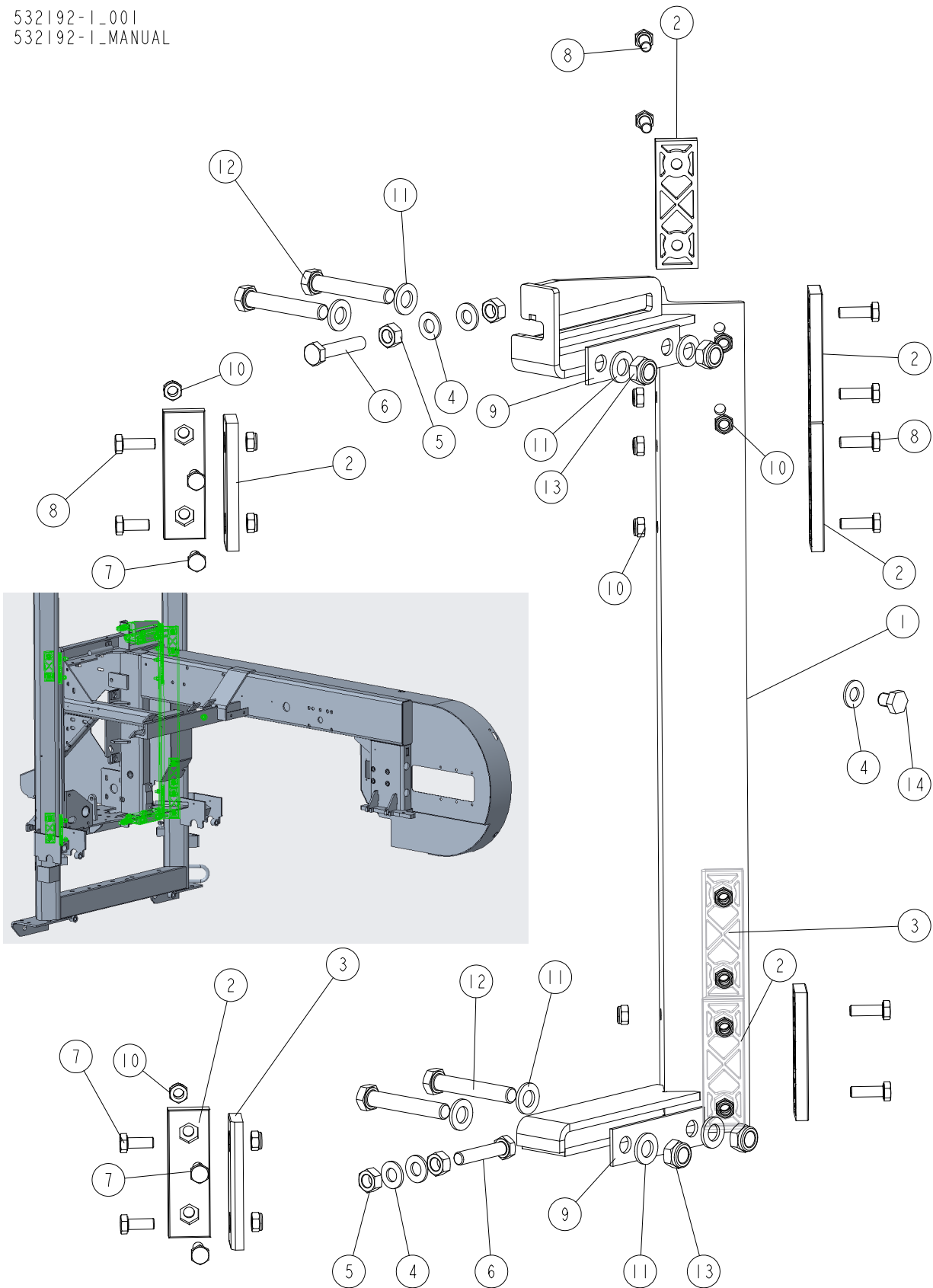

4

Saw Head*LT40 Wide Saw Head Parts*

REF.	DESCRIPTION (* indicates parts available in assemblies only)	PART #	QTY
-	SAW HEAD, LT40 AC/DC WIDE	532192-1	1
1	GUIDE WELDMENT, METRIC SAW HEAD REAR	087125	1
2	PADS, DELRIN UP/DOWN SLIDE	M04096	8
3	PAD, DELRIN LOWER	016241	2
4	WASHER, 10.5 FLAT ZINC	F81055-1	5
5	NUT, M10 8 HEX ZINC	F81033-3	4
6	BOLT, M10X50-8.8 HEX HEAD FULL THREAD ZINC	F81003-4	2
7	BOLT, M8X20 8.8 HEX HEAD FULL THREAD ZINC	F81002-4	6
8	BOLT, M8X25-8.8-B HEX HEAD FULL THREAD ZINC	F81002-5	14
9	PLATE, V-BRACE WASHER	091247	2
10	NUT, M8-8-B HEX NYLON ZINC LOCK	F81032-2	20
11	WASHER, 13 FLAT ZINC	F81056-1	8
12	BOLT, M12X75-8.8 HEX HEAD ZINC	F81004-21	4
13	NUT, M12-8 DIN 982 HEX NYLON ZINC LOCK	F81034-2	4
14	BOLT, M10X12 HEX HEAD FULL THREAD ZINC	F81003-30	1

4.17 Motor Mount Clamp

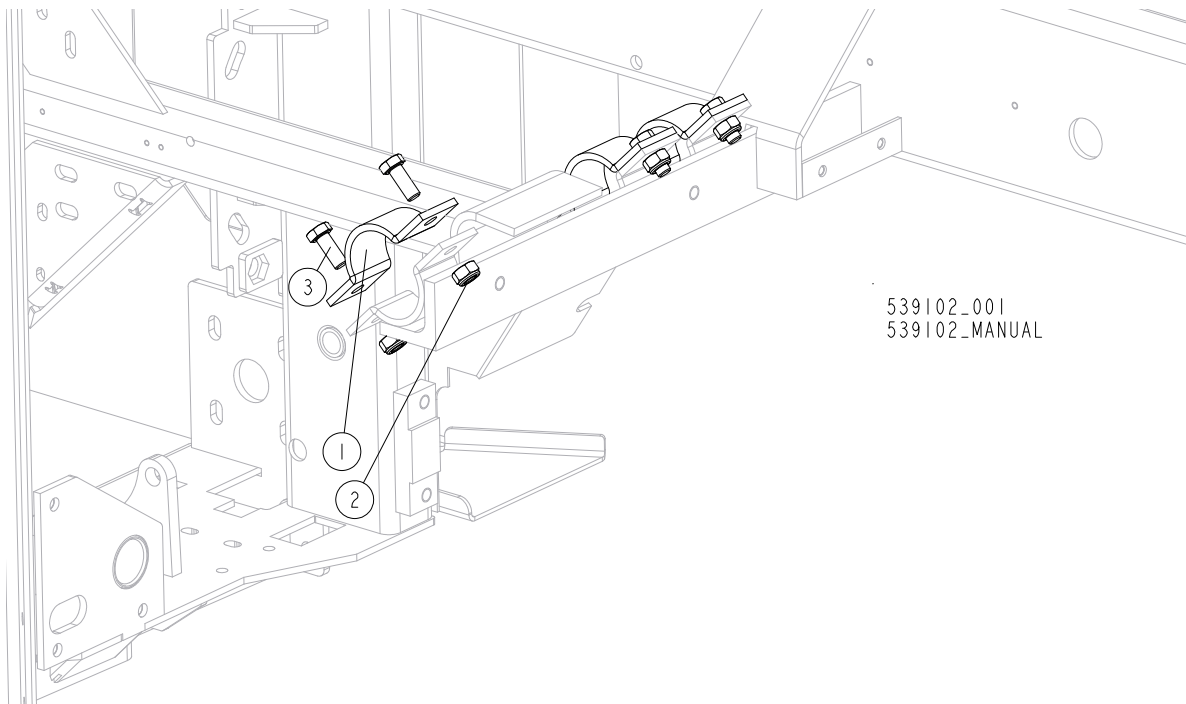

REF.	DESCRIPTION (* indicates parts available in assemblies only)	PART #	QTY	
1	CLAMP WELDMENT, MOTOR MOUNT	086200-1	3	
2	NUT, M10-8-B HEX NYLON ZINC LOCK	F81033-1	6	
3	BOLT, M10X25 8.8 HEX HEAD FULL THREAD ZINC	F81003-11	3	

4.18 Blade Guide Arm w/Drive

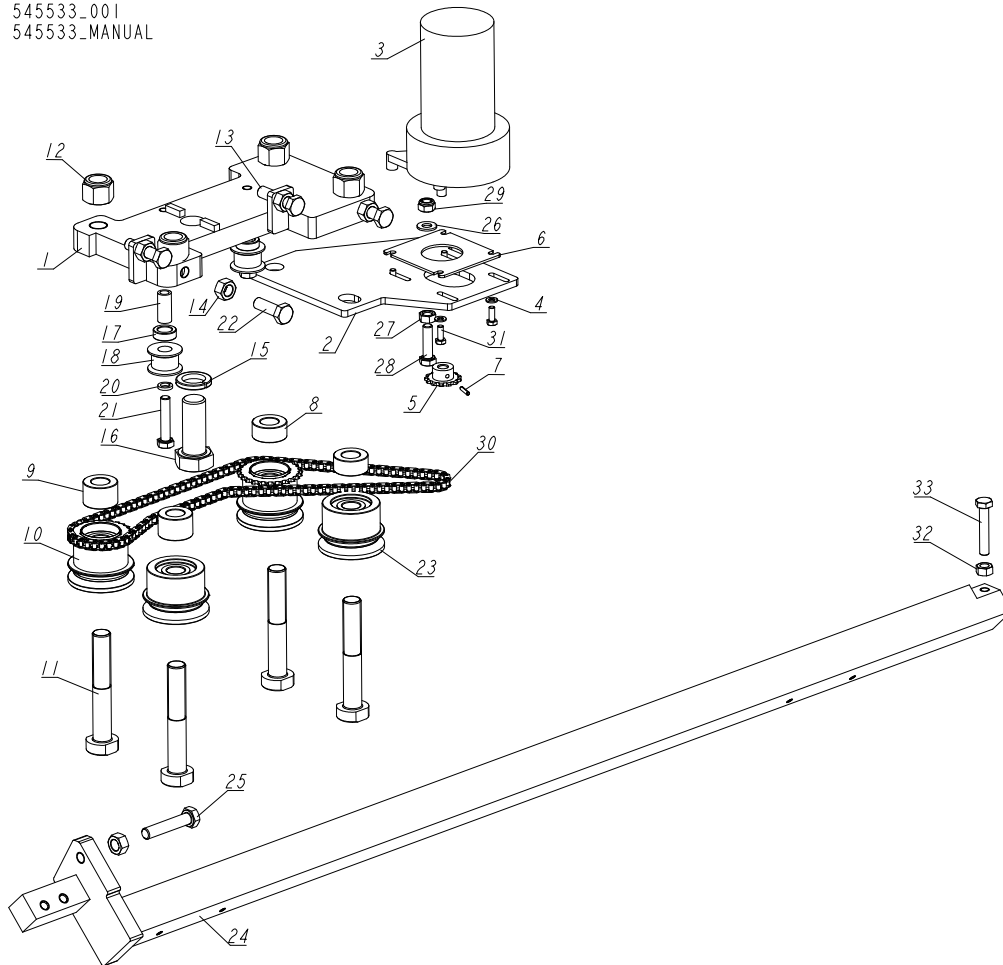
545533_001
545533_MANUAL

REF.	DESCRIPTION (* indicates parts available in assemblies only)	PART #	QTY
-	ARM, BLADE GUIDE W/DRIVE	545533	1
1	PLATE, BLADE GUIDE ARM DRIVE	545554-1	1
2	PLATE, ARM DRIVE MOUNT	557375-1	1
3	MOTOR, CURRENT APP. 1/30HP 12VDC GEAR	557161	1
4	WASHER, 5.3 FLAT ZINC	F81052-1	4
5	SPROCKET, 25B13X.3130	P09970	1
6	PLATE, SPACER	557376-1	1
7	PIN, 3X14 GEOMET ROLL	F81044-4	1
8	BUSHING, SPACER	520284-1	2
9	BUSHING, SPACER	520285-1	2
10	ROLLER, COMPLETE DRIVE	520282	2
11	PIN, MOUNTING	519660-1	4
12	NUT, 5/8-18 NYLON ZINC LOCK	F05010-71	4
13	BOLT, M10X40-8.8 HEX HEAD FULL THREAD ZINC	F81003-16	2
14	NUT, M10 8 HEX ZINC	F81033-3	5
15	WASHER, 20.5 SPLIT LOCK ZINC	F81059-1	1
16	BOLT, M20X50-8.8-B HEX HEAD FULL THREAD ZINC	F81007-17	1
17	BUSHING, 12.5/20-7 ZINC-PLATED	101063-1	2

REF.	DESCRIPTION (* indicates parts available in assemblies only)	PART #	QTY	
18	ROLLER, CHAIN TENSION	516193	2	
19	BUSHING, SPACER	519345-1	2	
20	WASHER, 8.2 SPLIT LOCK ZINC	F81054-4	2	
21	BOLT, M8X40-8.8 HEX HEAD FULL THREAD ZINC	F81002-15	2	
22	BOLT, DIN933-M10X30-8.8-A2E HEX HEAD FULL THREAD	F81003-111	4	
23	ROLLER, IDLER	520839	2	
24	ARM, BLADE GUIDE	545531-1	1	
25	BOLT, M10X50-8.8 HEX HEAD FULL THREAD ZINC	F81003-4	1	
26	WASHER, 8.4 FLAT ZINC	F81054-1	2	
27	NUT, M8 DIN 934 A2-70 STAINLESS STEEL	F81032-7	1	
28	BOLT, M8X30 8.8 HEX HEAD FULL THREAD ZINC	F81002-7	1	
29	NUT, M8-8-B HEX NYLON ZINC LOCK	F81032-2	1	
30	CHAIN, DRIVE	519358	1	
31	BOLT, #10-32X1/2 HH	F81000-35	4	
32	NUT, M8-8-B HEX ZINC	F81032-1	1	
33	BOLT, M8X45-8.8 HEX HEAD FULL THREAD ZINC	F81002-14	1	

SECTION 5 CONTROL & BATTERY BOXES

5.1 Control Assembly, LT40 Series DH

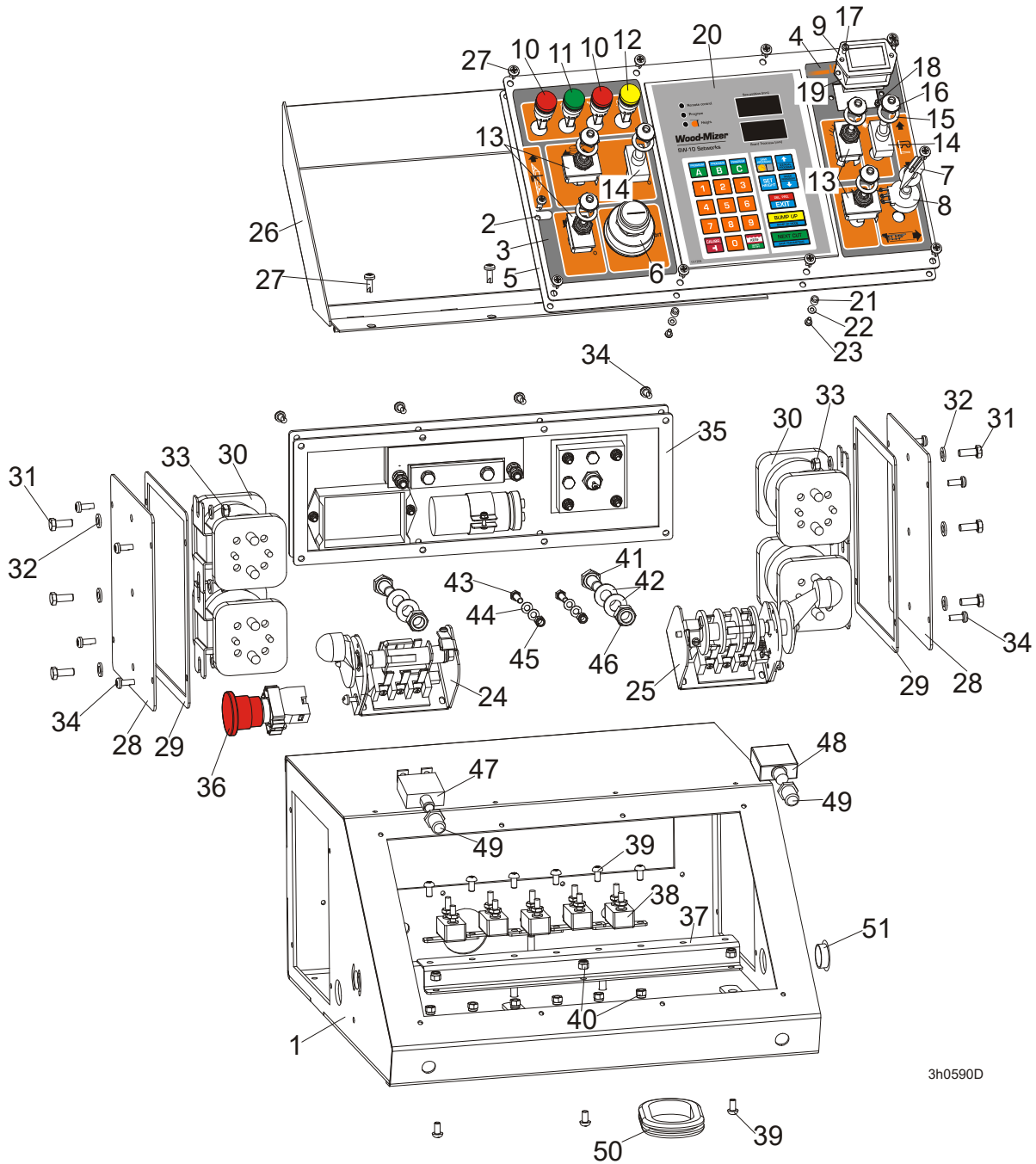

3h0590D

REF.	DESCRIPTION (◆ Indicates Parts Available In Assemblies Only)	PART #	QTY
	CONTROL BOX ASSEMBLY, LT40 DC	098375	1
	CONTROL BOX ASSEMBLY, LT40 DC - D25	570204	1
1	Box, LT40 Control	098373-1	1
	Panel, LT40 DC Front Control Complete	098691	1

2	Panel, LT20/40 DC Front Control	100573-1	1	
	Panel, LT40 DC Front Control	098376-1 ¹	1	
	Panel, LT40 DC Front Control, G38 Engine	545989-1	1	
3	Decal, LT40 DC Control Box Left	099595	1	
	Decal, LT40 DC Control Box Left, G38 Engine	539816	1	
4	Decal, LT40 DC Control Box Right	099596	1	
5	Gasket, LT20/40 Control Box	097132	1	
6	Switch, Key	P04350	1	
7	Knob, Speed Control	P06257	1	
8	Potentiometer, 1k Feed Rate	E20519	1	
9	Meter, Hour	093166	1	
10	Light, XB6AV4BB Red	091099	2	
11	Light, XB6AV3BB Green	087348	1	
12	Light, XB6AV5BB Yellow	089812	1	
13	Switch, Toggle	024200	4	
14	Switch, SPST On/Off 15A .25 TABS Toggle	P03027	2	
15	Washer, 1/2x3/4x1/16 Nylon	P05251-1	6	
16	Boot, Toggle Switch	P02575	6	
17	Bolt, M3x12-8.8 Zinc	F81000-12	2	
18	Nut, M3-6 Nylon Zinc Lock	F81028-2	2	
19	Gasket, Hour Meter	093346	1	
20	Controller, SW-10 Setworks	500628	1	
21	Spacer, 4.2x6mm Idler	R80671-4	6	
22	Washer, 3.2 Flat Zinc	F81050-2	6	
23	Screw, M3x8-4.8 Zinc	F81000-83	6	
24	Switch, 1992GS Pwr/Feed (Service Package)	E20438	1	
25	Switch, 1992 Up/Down (Service Package)	E20440	1	
26	Cover Weldment, LT20/40 Complete	097135-1	1	
27	Bolt, #10-24x1/2 Ph Pan Hd, Type 23	F05015-17	14	
	Solenoid Assembly, DC Up/Down	086747	1	
	Solenoid Assembly, DC Power Feed	086749	1	
	Cover, Control Box Side Complete	086700	1	
28	Cover, Control Box Side	086699-1	1	
29	Gasket, Control Box Side	015274	1	
30	Solenoid, 200A 12V DPST	015417	2	
31	Bolt, M6x16 8.8 Hex Head Full Thread Zinc	F81001-15	3	
32	Washer, 6.4 Flat Zinc	F81053-1	6	
33	Nut, M6-8-B Hex Nylon Lock Zinc	F81031-2	3	
34	Bolt, #10-24x1/2 Ph Pan Hd, Type 23	F05015-17	12	
	Panel Assy, Power Feed Control SMT 97+	024412	1	
35	Gasket, Power Feed Control	015278	1	
36	Switch, XB2 BS542 Emergency	086556	1	
	Breaker Assembly, Sawmill Control Circuit	086746	1	
37	Rail, Circuit Breaker	015310	1	◆
38	Breaker, 15A Manual Reset	E20430	5	◆
39	Screw, H M5x10 8.8 Zinc	F81000-13	9	
40	Nut, M5-8 Zinc	F81030-2	9	
41	Bolt, M10x20-5.8 Hex Head Full Thread Zinc	F81003-1	2	

42	Washer, 10.5 Flat Zinc	F81055-1	4	
43	Nut, M10-8-B Nylon Hex Zinc Lock	F81033-1	2	
44	Bolt, M5x16-8.8 Zinc	F81000-20	2	
45	Washer, 5.3 Flat Zinc	F81052-1	4	
46	Nut, M5-8 Zinc	F81030-2	2	
47	Breaker, 70A Manual Reset Panel Mount	015527	1	
48	Breaker, 50A Manual Reset Panel Mount	021256	1	
49	Boot, Circuit Breaker	021253	2	
50	Grommet, Rubber	087065	1	
51	Cap, SR1086 22.2 Dia. Hole	093544	1	
	Relay, Time P3SRP30-W4-C10 - D25	568555	1	

¹ Use in African version only.

5.2 Control Assembly (Gas/Diesel), Optional Equipment

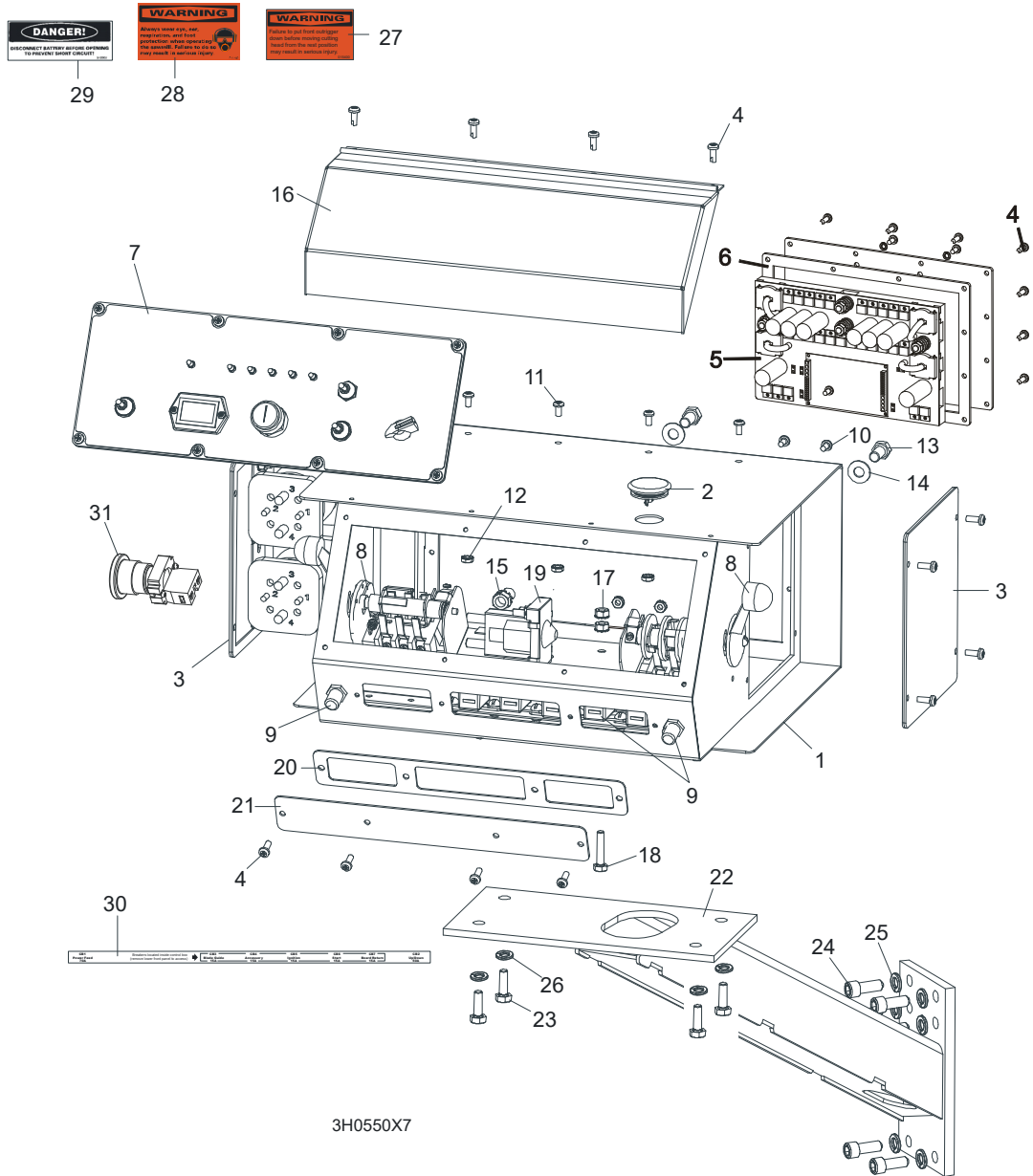

3H0550X7

REF.	DESCRIPTION (◆ Indicates Parts Available In Assemblies Only)	PART #	QTY
	CONTROL BOX ASSEMBLY, D42	095000	1
1	DC Control Box	095012-1	1
2	Plug, AS075 Oiltite	E20570	1
3	Solenoid Parts (See Section 5.6)		
4	Screw, #10-24 x 1/2" Pan Head	F05015-17	16
5	Panel Assembly, Power Feed Control	095010-1	1
	Circuit Board, Control Box Power Feed	051667	1
6	Gasket, Rear Access Panel	095011	1
7	Front Control Panel & Wiring Harnesses (Section 5.4)		
8	Drum Switches (Section 5.3)		
9	Circuit Breakers (Section 5.5)		
10	Screw, #10-24 x 3/8" Phillips Pan Head	F05004-3	2

11	Screw, #10-24 x 3/8" Phillips Pan Head Machine with Neo Washer	F05004-148	4	
12	Nut, #10-24 Self-Locking	F05010-14	6	
13	Bolt, 3/8-16 x 3/4" Hex Head	F05007-27	2	
14	Washer, 10.5 Flat	F81055-1	2	
15	Nut, 3/8" Lock Nut	F05010-19	2	
16	Cover, Control Box Hinged	015304	1	
17	Nut, 1/4-20 Self-Locking	F05010-9	2	
18	Bolt, 1/4-20 x 1 1/4" Hex Head Tap	F05005-3	1	
19	Solenoid, 200A 12V SPST	015470	1	
	Diode Assembly, Solenoid Coil Chassis GND	087496	1	
20	Gasket, Front Access Panel	015266	1	
21	Panel, Control Box Front Access	086704-1	1	
22	MOUNT WELDMENT, STANDARD CONTROL BOX	086732-1	1	
23	NUT, 5/16-18 SELF-LOCKING HEX	F05010-20	4	
24	BOLT, M10 X 25-8.8 SOCKET HEAD	F81003-32	4	
25	WASHER, 10.2 SPLIT LOCK	F81055-2	4	
26	WASHER, 3/8" EXTERIOR STAR LOCK	F05011-36	4	
27	DECAL, FRONT OUTRIGGER WARNING	015400	1	
28	DECAL, EAR/EYE PROTECTION WARNING	S11753	1	
29	DECAL, DISCONNECT BATTERY DANGER	S12002	1	
30	DECAL, CIRCUIT BREAKER ID ('98 SUPER)	024362	1	
31	SWITCH, RED EMERGENCY STOP XALJ174F	E22703-2	1	

5.3 Control Box Bracket

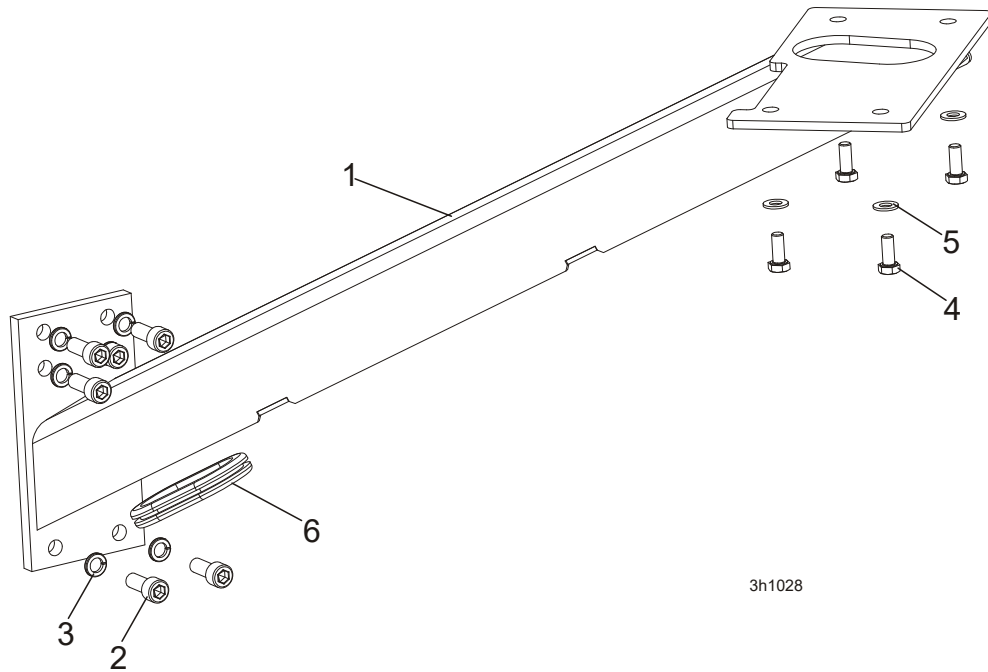

REF.	DESCRIPTION (◆ Indicates Parts Available In Assemblies Only)	PART #	QTY
1	MOUNT WELDMENT, STANDARD CONTROL BOX	086732-1	1
2	SCREW, M10x25 8.8 HEX SOCKET HEAD CAP ZINC	F81003-32	6
3	WASHER, 10.2 SPLIT LOCK ZINC	F81055-2	6
4	BOLT, M8X20-8.8-B HEX HEAD FULL THREAD ZINC	F81002-4	4
5	WASHER, 8.4 FLAT ZINC	F81054-1	4
6	GROMMET, RUBBER	087065	1

5.4 Drum Switches

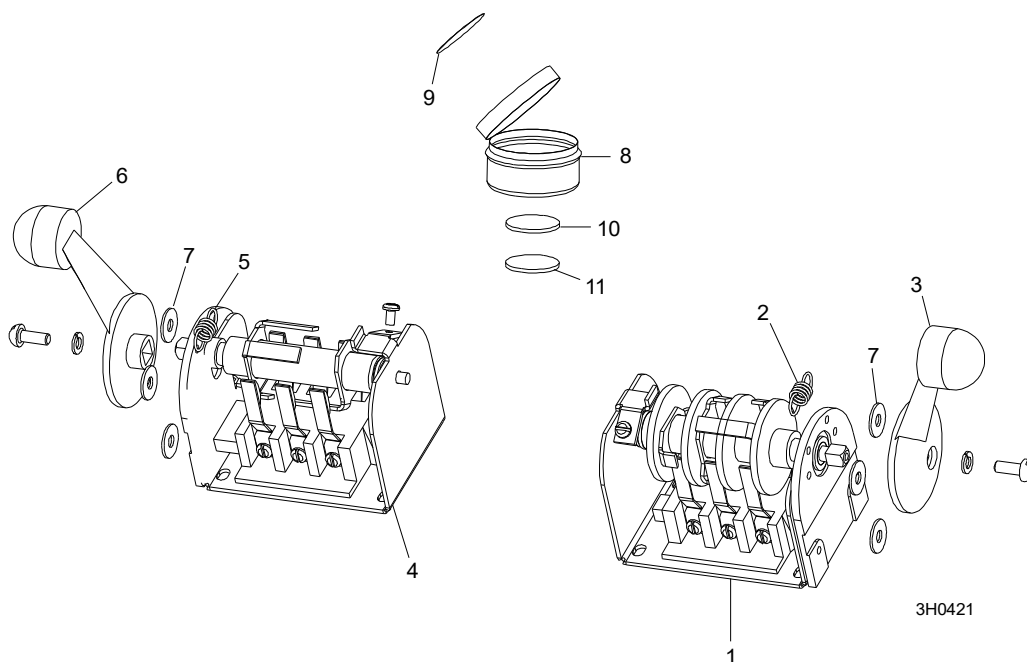

REF.	DESCRIPTION (◆ Indicates Parts Available In Assemblies Only)	PART #	QTY	
	SWITCH ASSEMBLY, UP/DOWN DRUM	E20440	1	
1	Switch, S12 Bulk Drum	E20440-B	1	◆
2	Spring, Drum Switch	P12570	1	
3	Handle, Drum Switch Replacement	P12500	1	
	SWITCH ASSEMBLY, POWER FEED DRUM	E20438	1	
4	Switch, S10 Bulk Drum	E20438-B	1	◆
5	Spring, Drum Switch	P12570	1	
6	Handle, Drum Switch Replacement	P12500	1	
7	WASHER, #8 SAE FLAT	F05011-41	6	
	CUP ASSEMBLY, DRUM SWITCH GREASE	A20463	1	
8	Cup, Plastic Container	P20464	1	◆
9	Decal, Grease Cup Label	P20467	1	
10	Pad, Velcro Loop	P20466	1	◆
11	Pad, Velcro Hook	P20465	1	◆
	Grease, High Temp Drum Switch	P20468	.011m	◆

5.5 Circuit Breakers

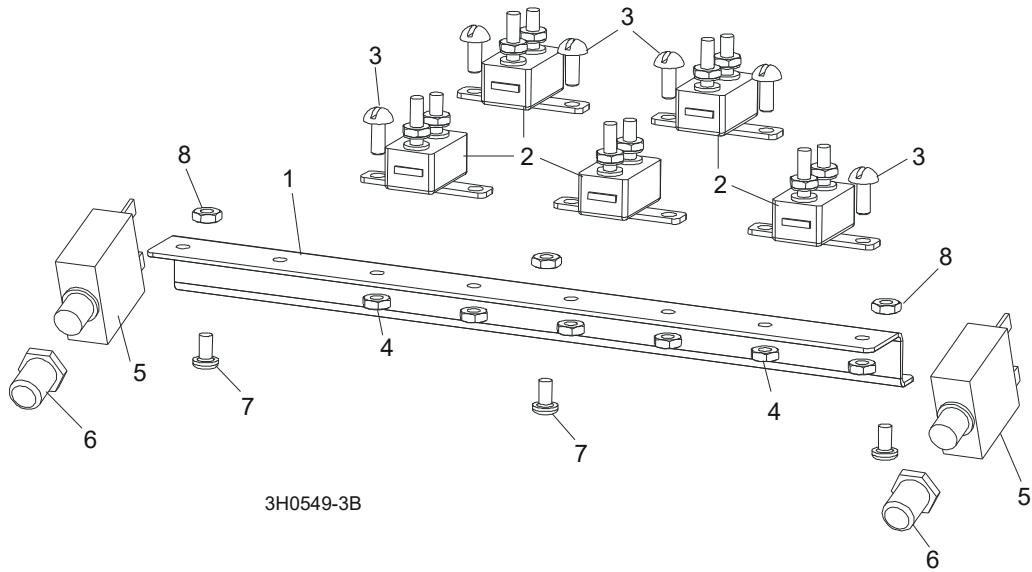

REF.	DESCRIPTION (◆ Indicates Parts Available In Assemblies Only)	PART #	QTY
1	RAIL, CIRCUIT BREAKER	525779-1	1
2	BREAKER, 15 AMP MANUAL RESET	E20430	5
3	SCREW, H M5X10 8.8 SLOTTED HEAD ZINC	F81000-13	6
4	NUT, M5-8 HEX SELF-LOCKING ZINC	F81030-2	6
5	BREAKER, 70 AMP MANUAL RESET PANEL MOUNT	015527	2
6	BOOT, CIRCUIT BREAKER	021253	2
7	BOLT, M5X12-5.8 ZINC	F81000-5	3
8	NUT, M5-8 SELF-LOCKING ZINC	F81030-2	3

5.6 Solenoid Assemblies

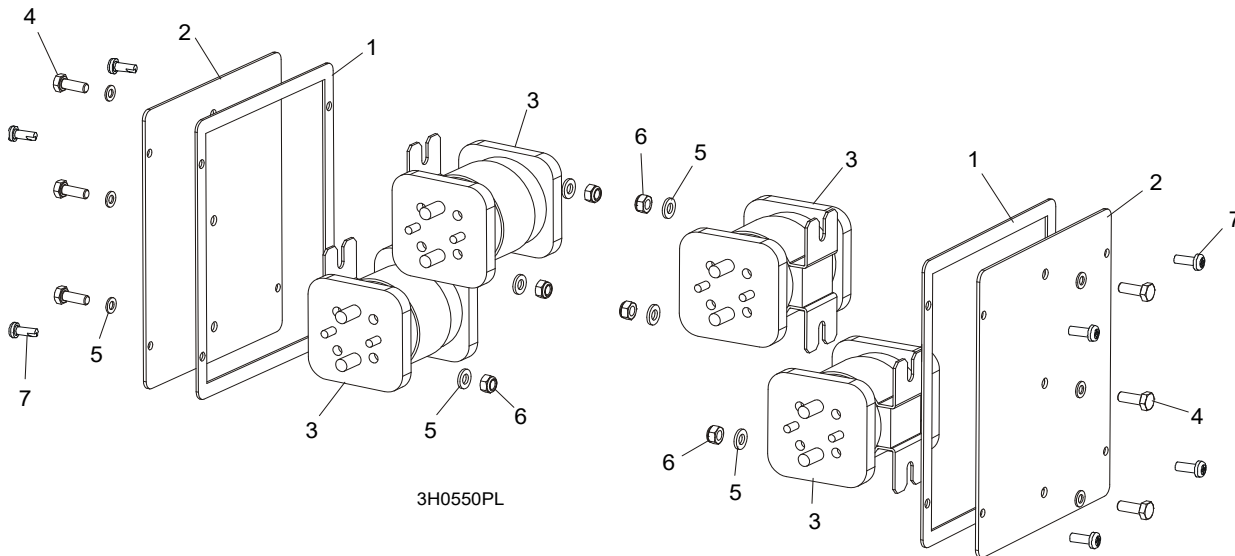

REF.	DESCRIPTION (◆ Indicates Parts Available In Assemblies Only)	PART #	QTY
1	GASKET, SIDE PANEL CONTROL	015274	2
2	PANEL WELDMENT, SIDE	086699-1	2
3	SOLENOID, 200A 12V DPST	015417	4
4	BOLT, M6X16 8.8 HEX HEAD FULL THREAD ZINC	F81001-15	6
5	WASHER, 6.4 FLAT	F81053-1	12
6	NUT, M6-8 HEX	F81031-2	6
	DIODE ASSEMBLY, SOLENOID COIL CHASSIS GND	087496	4
7	SCREW, #10-24 X 1/2" PAN HEAD	F05015-17	8

5.7 Battery Box Assembly, LT40DC Series MH

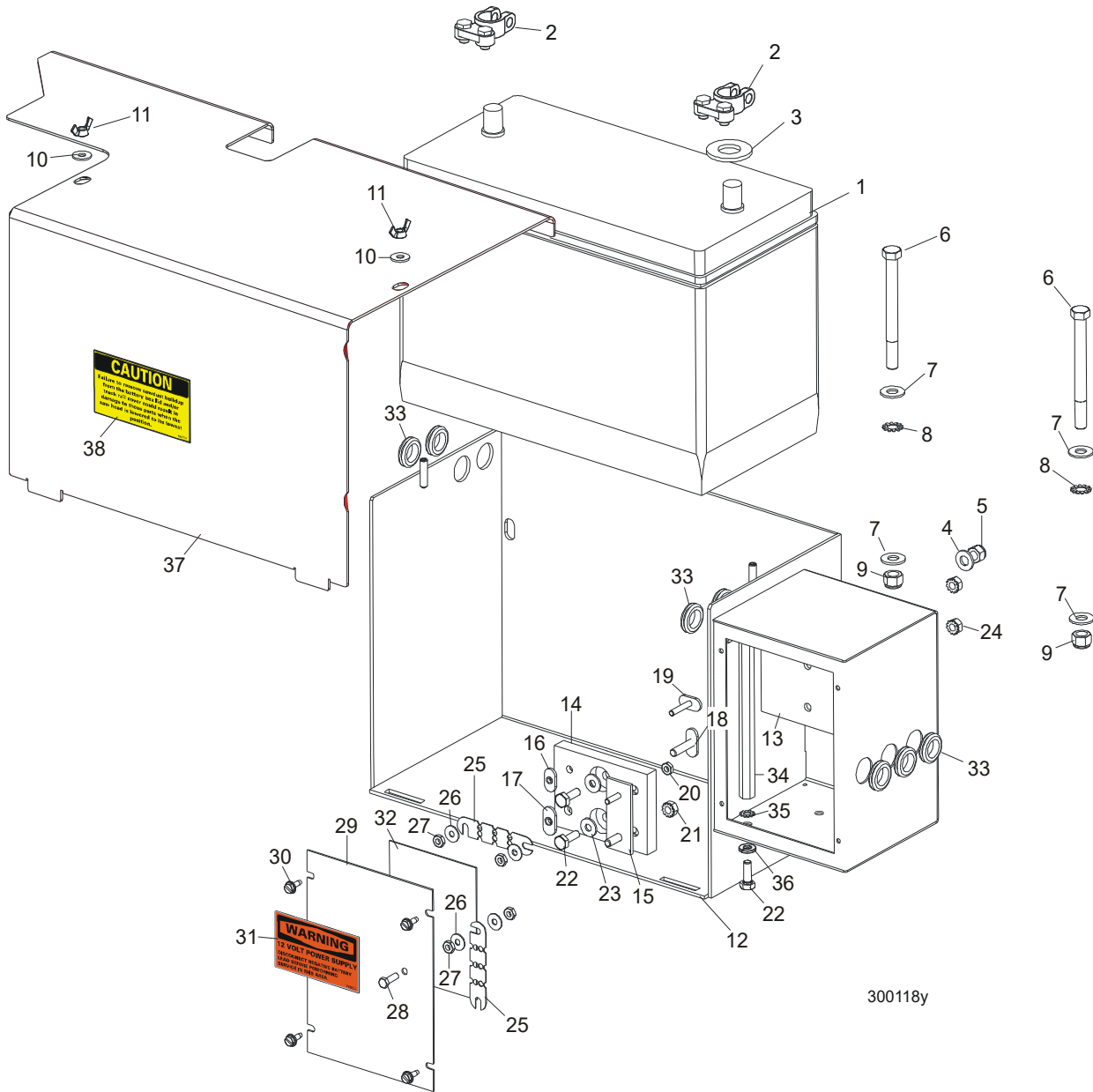

REF.	DESCRIPTION (◆ Indicates Parts Available In Assemblies Only)	PART NUMBER	QTY	
1	BATTERY, "BANNER" 12V100AH #95751	088323	1	◆
	BOX ASSEMBLY, LT30/LT40 SUPER BATTERY	086509	1	
2	Terminal, Battery	P05085	2	
3	Washer, Battery Terminal	P12161	1	
4	Washer, 5/16" SAE Flat	F05011-17	2	
5	Nut, 5/16-18 Hex Nylon Lock	F05010-58	2	
6	Bolt, 3/8-16 X 4" Hex Head Grade 2	F05007-4	2	
7	Washer, 3/8" SAE Flat	F05011-3	2	
8	Washer, 3/8" External Star	F05011-36	2	
9	Nut, 3/8" Hex Nylon Lock	F05010-10	2	
10	Washer, 1/4" SAE Flat	F05011-11	2	

11	Nut, 1/4-20 Wing	F05010-13	2	
12	Box Weldment, Battery	086265-1	1	
13	Pad, Fuse Box Insulator	015287	1	
	Fuse Block Assembly	017665	1	
14	Block, Fuse Mount	015286	1	◆
15	Buss Weldment, Fuse Mount	015289	1	
16	Nut, #10-24 Cadmium Plated Weld	S12391	1	
17	Nut, 1/4-20 Cadmium Plated Weld	S12392	1	
18	Stud Weldment, 1/4-20 Fuse	W12389	1	
19	Stud Weldment, #10-24 Fuse	W12390	1	
20	Nut, #10-24 Self-Locking Hex	F05010-14	1	
21	Nut, 1/4-20 Self-Locking Hex	F05010-9	1	
22	Bolt, 1/4-20 X 3/4" Hex Head Full Thread	F05005-1	3	
23	Washer, 1/4" SAE Flat	F05011-11	2	
24	Nut, 1/4-20 Hex Self-Locking	F05010-9	2	
25	Fuse Link, 12 Volt 150 Amp	023361	2	
26	Washer, #10 SAE Flat	F05011-18	4	
27	Nut, #10-24 Hex Self-Locking	F05010-14	4	
28	Screw, #10-24 x 5/8" Hex Head	F05004-18	1	
29	Cover, Fuse Box	086272-1	1	
30	Screw, #10-24 X 1/2" Self-Tapping	F05015-7	4	
31	Decal, 12 Volt Warning	P10364	1	
32	Decal, Fuse Link 150A I.D.	015369	1	
33	Grommet, 5/8" Rubber Wire	P11764	5	
34	Terminal, Extended Hex Stud	015517	1	
35	Washer, 1/4" Exterior Star	F05011-37	1	
36	Washer, 1/4" Split Lock	F05011-14	1	
37	LID WELDMENT, BATTERY BOX SUPER	086277-1	1	
38	DECAL, BATTERY BOX LID CAUTION	014774	1	

086509_001_A
086509_MANUAL

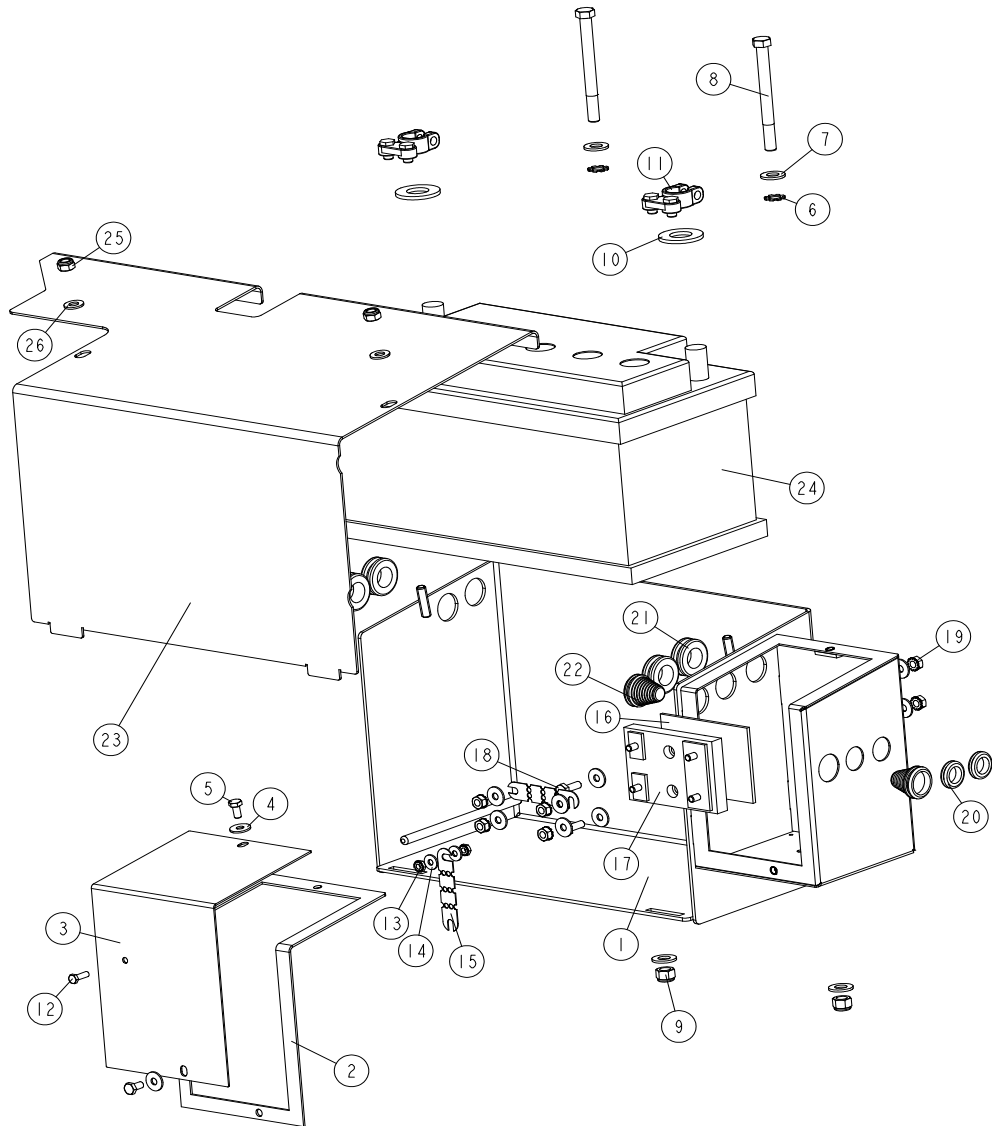

REF.	DESCRIPTION (* indicates parts available in assemblies only)	PART #	QTY
-	BOX ASSEMBLY, LT40SHD/LT40MHD BATTERY	086509	1
1	BOX WELDMENT, BATTERY	086265-1	1
2	GASKET, FUSE BOX	092226	1
3	LID, FUSE BOX	092222-1	1
4	WASHER, 6.5 SPECIAL FLAT ZINC-PL.	F81053-11	10
5	BOLT, M6X12-8.8 HEX HEAD FULL THREAD ZIN	F81001-7	2
6	WASHER, 10.5 EXTERNAL TOOTH ZINC LOCK	F81055-3	2
7	WASHER 10,5 ZC DIN 126 ISO 7091	F81055-1	4
8	BOLT, 3/8-16 X 4" HEX HEAD GRADE 2	F05007-4	2
9	NUT, 3/8-16 HEX NYLON LOCK	F05010-10	2
10	WASHER, FELT BATTERY TERMINAL	P12161	2
11	TERMINAL, BATTERY	P05085	2

REF.	DESCRIPTION (* indicates parts available in assemblies only)	PART #	QTY	
12	SCREW, #10-24 X 5/8" HEX HEAD	F05004-18	1	
13	NUT, #10-24 SELF-LOCKING	F05010-14	2	
14	WASHER, 5.5 SPECIAL FLAT ZINC	F81052-3	2	
15	FUSE LINK, 12 VOLT 150 AMP	023361	2	
16	PLATE, 3MM PLASTIC FUSE BOX	585483	1	
17	BLOCK, RELAY	585482	1	
18	BOLT, 1/4-20X3/4 FT HHC	F05005-1	2	
19	NUT, 1/4-20 SELF-LOCKING HEX ZINC	F05010-9	6	
20	GROMMET, 5/8" RUBBER WIRE	P11764	2	
21	GROMMET, RUBBER 3/4 ID	025247	4	
22	GROMMET, 1709 (26/3/10-22) STEPPED	098816	2	
23	LID WELDMENT, BATTERY BOX SUPER	086277-1	1	
24	BATTERY, "BANNER" 12V100AH	088323	1	
25	NUT, M8-8-B HEX NYLON ZINC LOCK	F81032-2	2	
26	WASHER, 8.4 FLAT ZINC	F81054-1	2	

SECTION 6 UP/DOWN SYSTEM

6.1 Saw Head V-Brace Mount

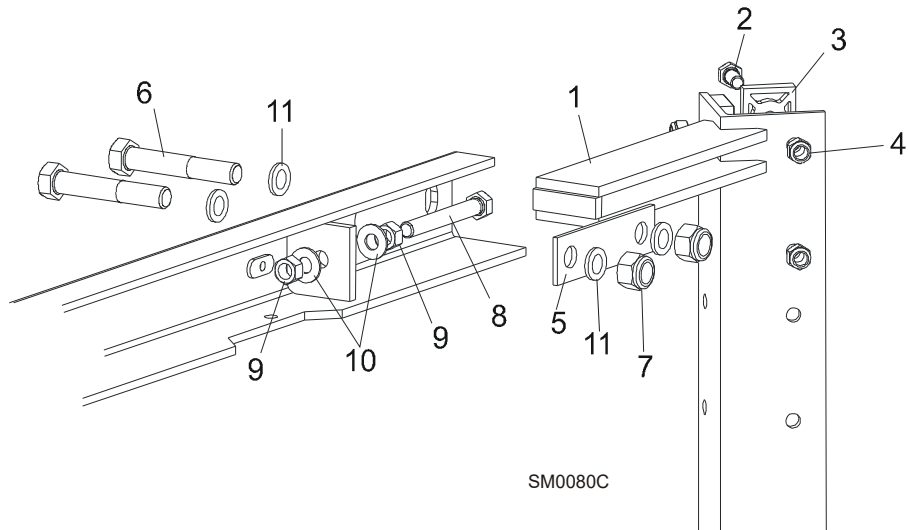

REF.	DESCRIPTION (◆ Indicates Parts Available In Assemblies Only)	PART #	QTY
1	V-BRACE, SAW HEAD MOUNT	087125	1
2	BOLT, M8X20-5.8-ZINC HEX HEAD	F81002-4	10
	BOLT, M8X25-8.8-B-ZINC HEX HEAD	F81002-5	2
3	PAD, PLASTIC SLIDE	M04096	6
4	NUT, M8-8-B-ZINC HEX NYLON LOCK	F81032-2	12
5	PLATE, V-BRACE WASHER	091247	2
6	BOLT, M12X75-8.8-ZINC	F81004-21	4
7	NUT, M12 - 8 NYLON LOCK	F81034-2	4
8	BOLT, M10X70-8.8-ZINC HEX HEAD	F81003-20	2
9	NUT, M10-8-B-ZINC HEX	F81033-3	4
10	WASHER, 10.5 FLAT	F81055-1	4
11	WASHER, 13 SPLIT LOCK ZINC	F81056-1	8

6.2 Blade Height Scale

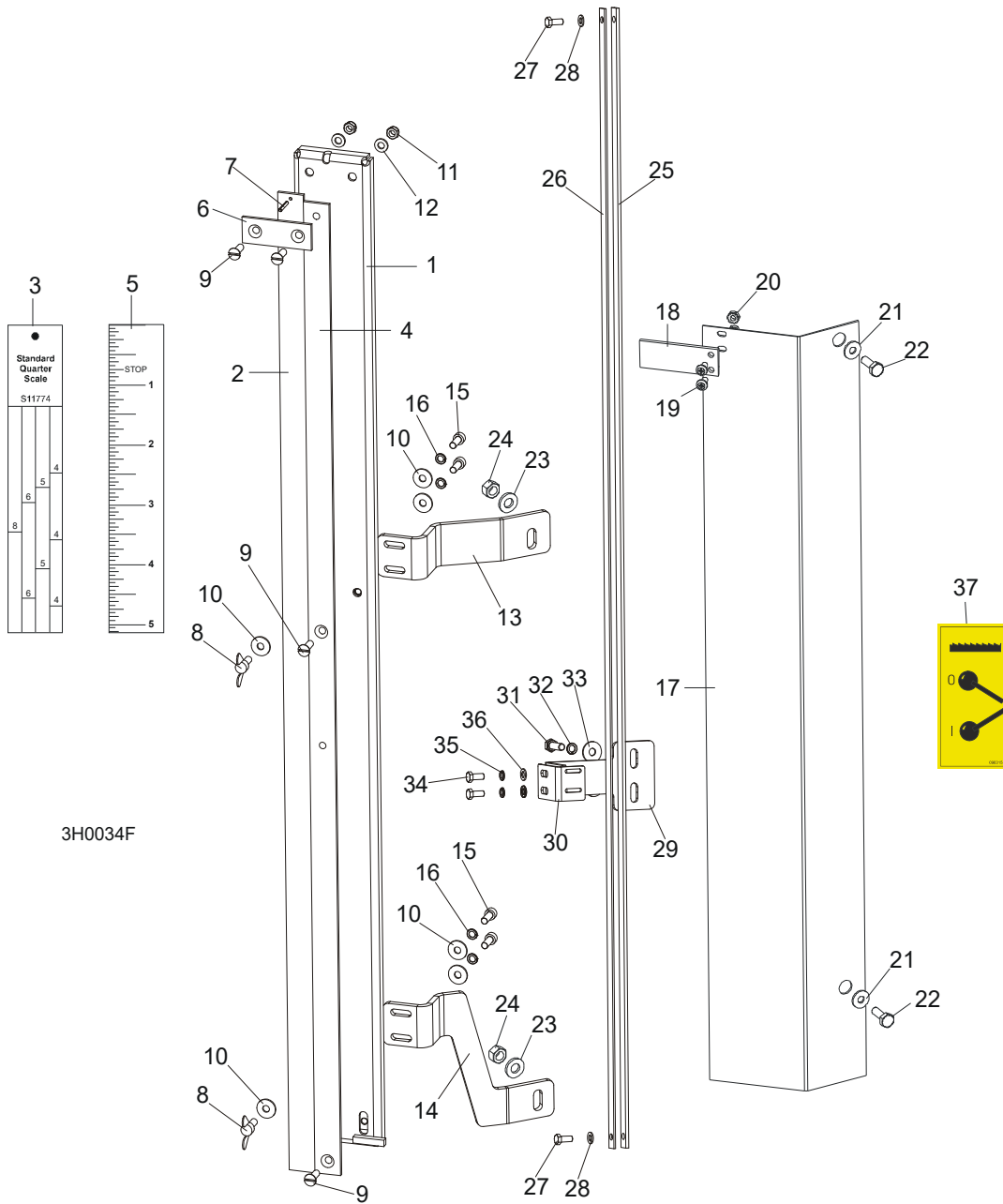

3H0034F

REF.	DESCRIPTION (◆ Indicates Parts Available In Assemblies Only)	PART #	QTY
	SCALE, BLADE HEIGHT W/SCANNER	098882	1
1	Bracket, Scale Mounting	098890-1	1
2	Scale, 35" Quarter	093342	1
3	Decal, 35" Standard Quarter Scale	090716	1
	Decal, 35" Grade Hardwood Quarter Scale	090717	1
4	Scale, 35" Inch	093341	1
5	Decal, 35" Inch	090709	1
6	Strap, Scale Hold-Down	093134	1
7	Pin, 3x20 Roll	F81044-5	1

8	Screw, M6x16 Wing	F81001-16	2	
9	Screw, M6x20- 4.8-B	F81001-31	4	
10	Washer, 6.5 Flat	F81053-11	7	
11	Nut, M6-8-B Hex Nylon Lock Zinc	F81031-2	2	
12	Washer, 6.4 Flat Zinc	F81053-1	2	
13	Bracket, Scale Upper	098880-1	1	
14	Bracket, Scale Lower	505618-1	1	
15	Screw, M6x16-8.8 Hex Socket Head Cap Zinc	F81001-21	4	
16	Washer, Z6.1 Split Lock Zinc	F81053-3	4	
	Pointer Assembly, Fixed Scale	A12023	1	
17	Bracket, Fixed Scale Pointer Mount	087044-1	1	◆
18	Indicator, Blade Height Scale	094821	1	
19	Screw, M4x25-8.8 Hex Socket Head Cap Zinc	F81011-43	2	
20	Nut, M4-B Hex Nylon Zinc Lock	F81029-1	2	
21	Washer, 6.5 Flat	F81053-11	2	
22	Bolt, M6x12-8.8 Hex Head Full Thread Zinc	F81001-7	2	
23	Washer, 8.4 Flat	F81054-1	2	
24	Nut, M8-8-B Hex Lock	F81032-2	2	
	MAGNETIC STRIP ASSY	097774	1	
	Bar with Magnetic Strip	098173-1	1	
25	Magnetic Strip MB320 (1m)	096014-1	1	
26	Bar, Magnetic Strip	098173	1	
27	Bolt, M5 X 12-8.8 Hex Head Full Thread Zinc	F81000-5	2	
28	Washer, 5.3 Flat Zinc	F81052-1	2	
	BRACKET, SENSOR COMPLETE	100620	1	
29	Bracket, Sensor	100599-1	1	
30	Bracket, Sensor	100619-1	1	
31	Bolt, M6x20-8.8 Hex Head Full Thread Zinc	F81001-2	2	
32	Washer, Z6.1 Split Lock Zinc	F81053-3	2	
33	Washer, 6.5 Flat Zinc	F81053-11	2	
34	Bolt, M5 X 12-5.8 Hex Head Full Thread Zinc	F81000-5	2	
35	Washer, 5.1 Split Lock Zinc	F81052-2	2	
36	Washer, 5.3 Flat Zinc	F81052-1	2	
	DECAL KIT, METRIC SCALE	K12064	1	
	Decal, Metric	S11711	1	
	Decal, Metric 16-40mm	P12040-1	1	
	Decal, Metric 45-63mm	P12040-2	1	
37	DECAL, CLUTCH HANDLE OPERATION, PICTOGRAM	096315	1	

6.3 Up/Down Chain & Sprockets

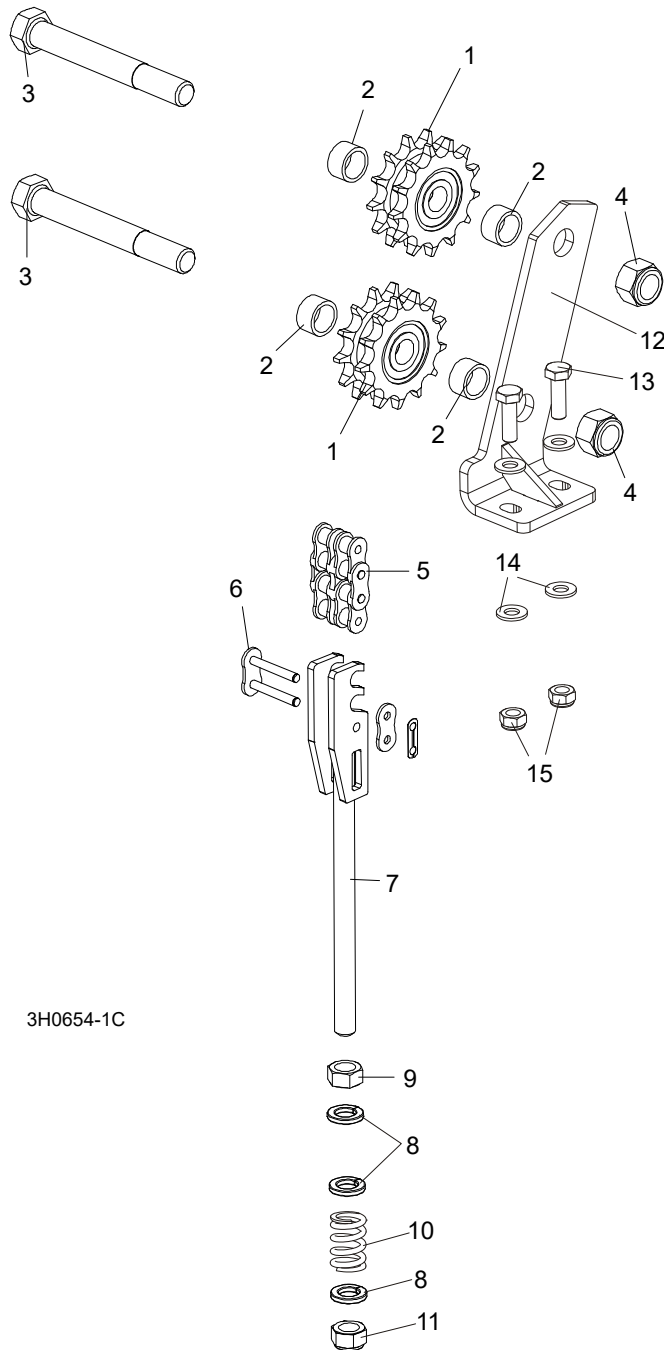

3H0654-1C

REF.	DESCRIPTION (◆ Indicates Parts Available In Assemblies Only)	PART #	QTY
	SPROCKET KIT, UP/DOWN IDLER #50-2	016020	1
1	Sprocket, Up/Down Idler '98	016019	2
2	Washer, Sprocket Spacer	095927-1	4
	Instruction Sheet, Up/Down Idler Retrofit	016020-541	1
3	BOLT, 5/8-11 X 5" HEX HEAD GRADE 2	F05009-6	2
4	NUT, 5/8-11 HEX NYLON LOCK	F05010-34	2
	CHAIN, IWIS 10B-2, COMPLETE	518534	1

5	Chain, IWIS 10B-2-121 Links, DIN 8187-1	518535	1	
6	Link, 10B-2, DIN 8187-1 Master	518536	1	
	TENSIONER ASSEMBLY, UP/DOWN CHAIN	094283	1	
7	Bracket, Up/Down Chain Tensioner	094281-1	1	◆
8	Washer, 13 Flat Zinc	F81056-1	3	
9	Nut, M12-8-B Hex	F81034-1	1	
10	Spring, 14x30x3.2	090797	1	
11	Nut, M12-8 Hex Nylon Zinc Lock	F81034-2	1	
12	PLATE, UP/DOWN SPROCKET - COMPLETE	507026-1	1	
13	BOLT, M8X25-8.8-B HEX HEAD FULL THREAD	F81002-5	2	
14	WASHER, 8.4 FLAT ZINC	F81054-1	4	
15	NUT, M8-8-B HEX NYLON LOCK ZINC	F81032-2	2	

6.4 Up/Down Motor Assembly, LT40 Series

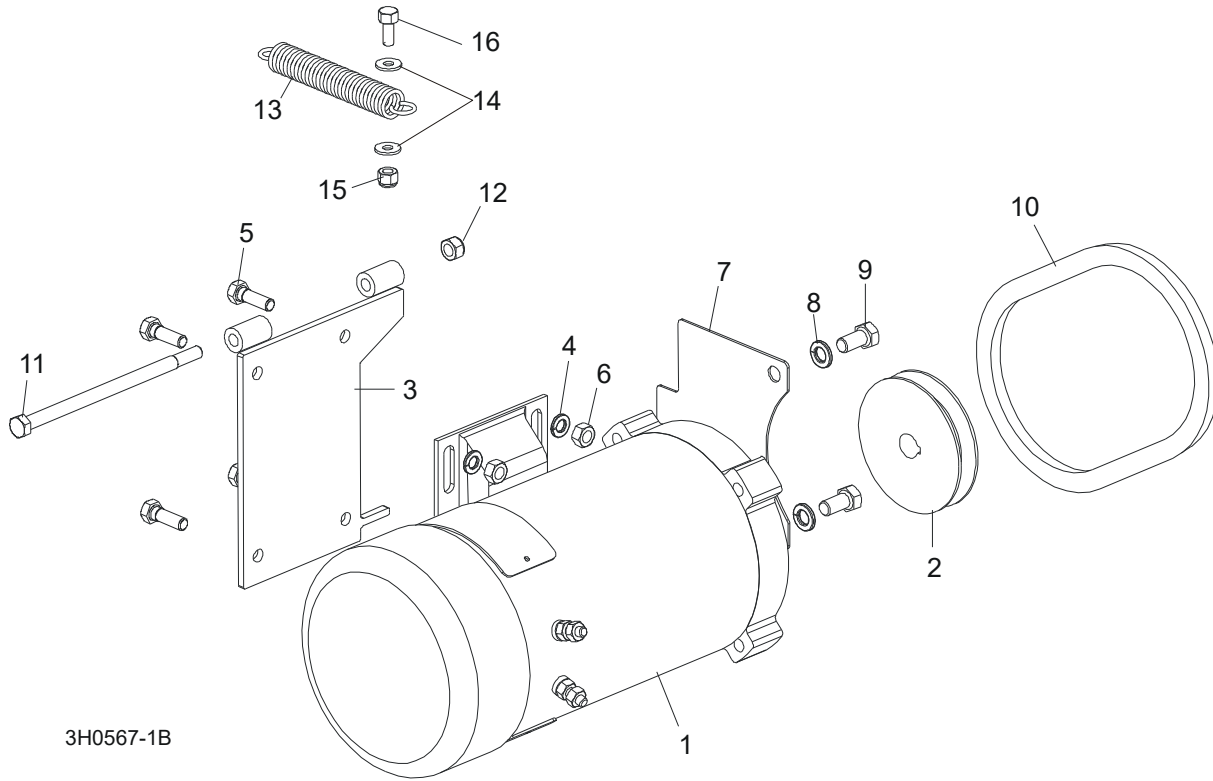

3H0567-1B

REF.	DESCRIPTION (◆ Indicates Parts Available In Assemblies Only)	PART #	QTY
	UP/DOWN MOTOR ASSEMBLY	092818	1
1	Motor, 3/4 HP Electric	015174	1
	Brush Kit, Power Feed Motor (Includes 2 Brushes and 2 Springs)	024167	1
	Fan, 3/4 HP Leeson Motor Replacement	016087	1
	Brake, HPS 10.84 230VAC LT40	083607	1
2	Pulley, AK28 x 5/8"	033852	1
3	Bracket Wldmt, Up/Down Motor	095738-1	1
4	Washer, 8.4 Flat Zinc	F81054-1	4
5	Bolt, M8x20-8.8-B Hex Head Full Thread Zinc	F81002-4	4
6	Nut, M8-8-B Hex Nylon Lock Zinc	F81032-2	4
7	Guard, Up/Down Sprocket	095739-1	1
8	Washer, 10.2 Split Lock	F81055-2	2
9	Bolt, 3/8-16 x 3/4" Hex Head	F05007-27	2
10	BELT, 4L245	038459	1
11	BOLT, M8X160-8.8-B ZINC	F81002-22	1
12	NUT, M8-8-B NYLON LOCK HEX ZINC	F81032-2	1
13	SPRING, .75" X 5" X .095" EXTENSION	015569	1
14	WASHER, 6.5 FLAT ZINC	F81053-11	2
15	NUT, M6-8-B NYLON LOCK HEX ZINC	F81031-2	2
16	BOLT, M6x25-8.8 ZINC	F81001-20	1

6.5 Up/Down Drive Assembly, LT40 Series

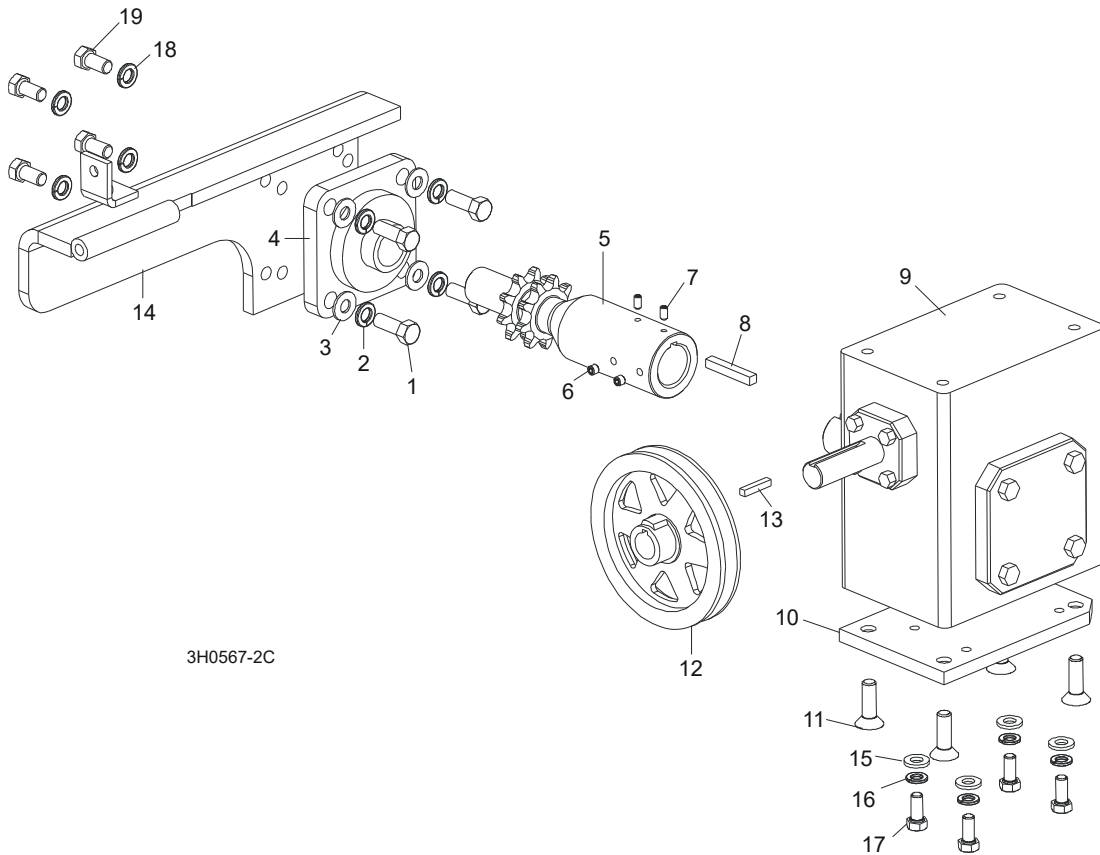

3H0567-2C

REF.	DESCRIPTION (◆ Indicates Parts Available In Assemblies Only)	PART #	QTY
	UP/DOWN DRIVE ASSEMBLY	092817	1
1	Bolt, 3/8-16 x 1" Hex Head	F05007-7	4
2	Washer, 10.2 Split Lock	F81055-2	4
3	Washer, 10.5 Flat	F81055-1	4
4	Bearing, Flanged Up/Down	014090	1
5	Shaft, Up/Down Sprocket	092816-1	1
6	Screw, M8 x 8-33H	F81014-1	2
7	Screw, M8 x 8-33H	F81014-1	2
8	Key, 1/4" Square x 1 11/16" Long	S04124	1
9	Reducer, Gear Box	518041	1
10	Plate, Gear Box Spacer	095894-1	1
11	Bolt, 3/8-16 x 1" Flat Socket Head	F05007-110	4
12	Pulley, Up/Down	015256	1
13	Key, 3/16" Square x 1" Long	S31027	1
14	Bracket Wldmt, Up/Down Bearing	095893-1	1
15	WASHER, 8.4 FLAT	F81054-1	8
16	WASHER, 8.2 SPLIT LOCK	F81054-4	4
17	BOLT, 5/16-18 X 1" HEX HEAD	F05006-5	4
18	WASHER, 10.5 SPLIT LOCK	F81055-1	4
19	BOLT, 3/8-16 X 3/4" HEX HEAD	F05007-27	4
	OIL, 8 OZ. MOBIL SHC634 BOTTLED SYNTHETIC GEAR	L04869-4	1

SECTION 7 POWER FEED & TRACK ROLLERS

7.1 Upper Track Rollers And Wipers

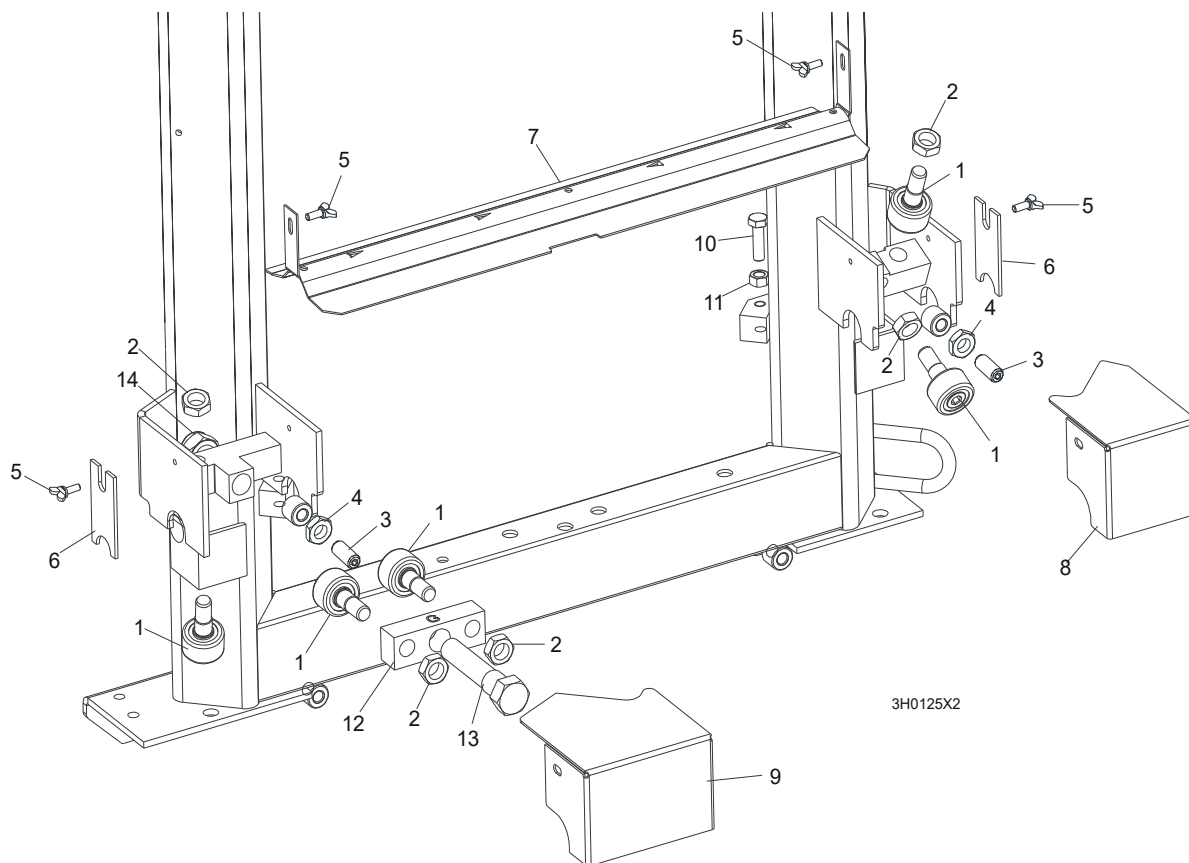

REF.	DESCRIPTION (◆ Indicates Parts Available In Assemblies Only)	PART #	QTY
1	ROLLER, TRACK CAM BEARING (MCGILL)	012797	5
2	NUT, 5/8-18 HEX JAM	F05010-11	5
3	SCREW, M12 X 30 OVAL POINT SET	F81004-14	2
4	NUT, M12-8-B HEX JAM	F81034-1	2
5	SCREW, M6 X 16 THUMB	F81001-16	4
6	WIPER, PLASTIC TRACK	M04113	2
7	COVER, LT40/70 MIDDLE TRACK - SERVICE	522292-S	1
	Cover, LT40/70 Middle Track	522292-1	1
	Strip, 3/16 X 2 X 23 Felt	S09915	1
8	HOUSING, UPPER TRACK ROLLER REAR	086913-1	1
9	HOUSING, UPPER TRACK ROLLER FRONT	086914-1	1
10	BOLT, M10 X 35-8.8 HEX HEAD	F81003-17	2
11	NUT, M10-8 HEX JAM	F81033-3	2
12	BRACKET, UPPER TRACK ROLLER	086859-1	1
13	BOLT, HEX HEAD	086911	1
14	NUT, M20-8 HEX	F81037-2	1

7.2 Power Feed Assembly

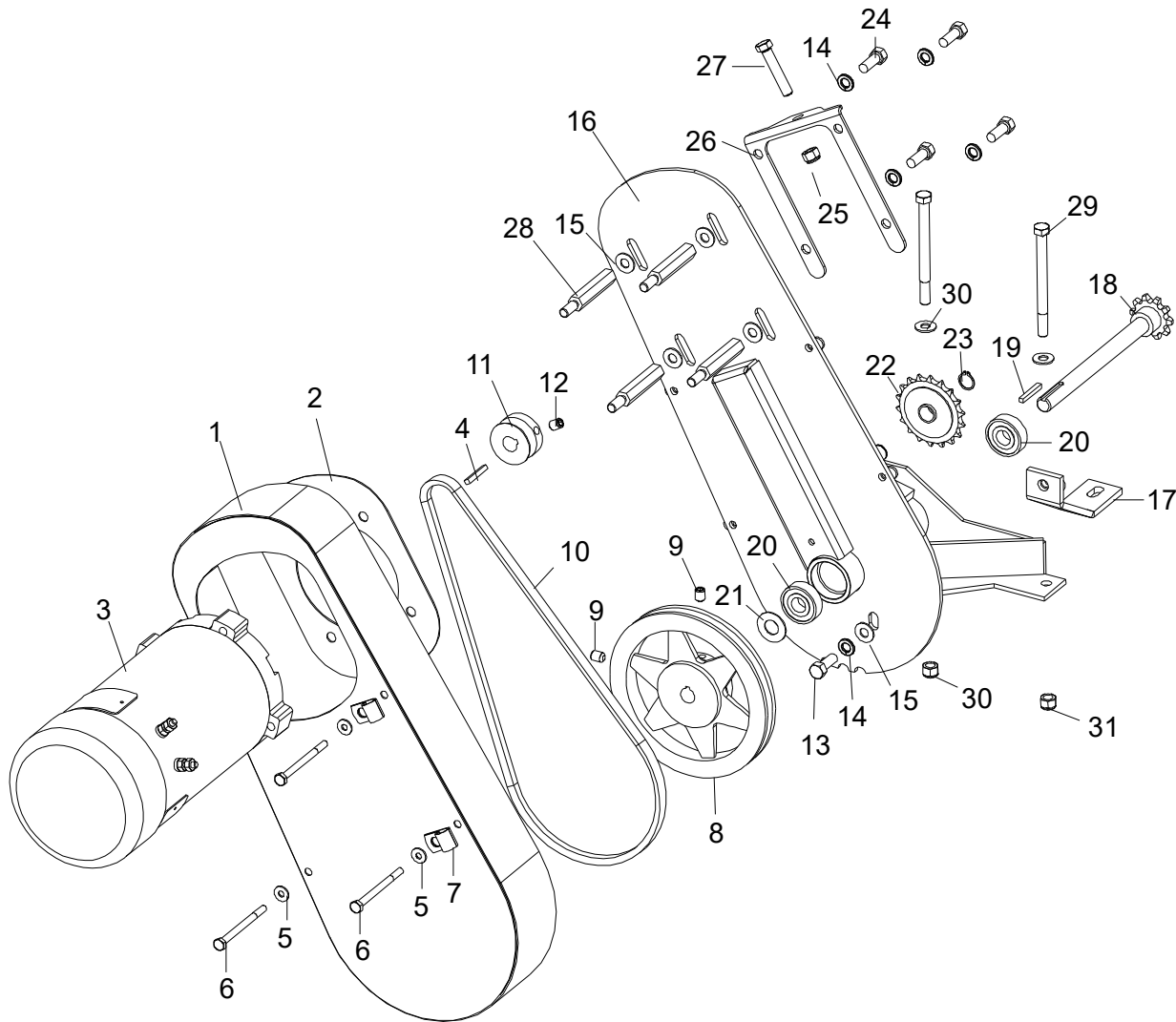

3H0619-2

REF.	DESCRIPTION (◆ Indicates Parts Available In Assemblies Only)	PART #	QTY
	POWER FEED ASSEMBLY	015125	1
1	Cover Weldment, Top Power Feed	015126	1
2	Plate, Power Feed Motor	601628-1	1
3	Motor, 3/4HP Power Feed	024169	1
	Brush Kit, Leeson 3/4HP Motor (Includes 2 Brushes and 2 Springs)	024167	1
	Fan, 3/4 HP Leeson Motor Replacement	016087	1
4	Key, 3/16" Square x 1 3/8" Long	016109	1
5	Washer, 6.5 Flat	F81053-11	4
6	Bolt, M6x80 Hex Head Zinc	F81001-61	4
7	Clamp, 1/2" EMT Coated	P07584	2
8	Sheave, AK71 x 5/8" Power Feed (200ft./min.)	016088	1

7 Power Feed & Track Rollers

Power Feed Assembly

9	Screw, 5/16-18 x 3/4" Cup Point Set	F05006-32	2	
10	Belt, AX36 (200ft./min.)	016083	1	
11	Sheave, 1 3/4" Feed Motor	015135	1	
12	Screw, 3/8"-16 x 1/2" Cup Point Set	F05007-12	1	
13	Bolt, M10x25-8.8 Hex Head Zinc	F81003-11	1	
14	Washer, 10.2 Split Lock	F81055-2	5	
15	Washer, 10.5 Flat	F81055-1	5	
16	Bracket, Power Feed Mount	015162-1	1	
17	Brace Weldment, Power Feed Mounting	086554-1	1	
	Shaft Assembly, Power Feed with Key	016066	1	
18	Shaft Weldment, Power Feed	015129	1	◆
19	Key, 3/16" Square x 1 3/8" Long	016108	1	
20	Bearing, 6203 2RSP6-5/8 CX	095087	2	
21	Washer, 5/8" x 15/16" x .094" Nylon	F05011-19	1	
22	Sprocket, 40 Idler 18T 5/8" ID	P04333	1	
23	Ring, Z15 Outer Retaining	F81090-2	1	
24	Bolt, 3/8-16 x 3/4" Hex Head	F05007-27	4	
25	Nut, 3/8-16 Hex Nylon Lock	F05010-10	1	
26	Plate, Belt Tensioner	015134	1	
27	Bolt, 3/8-16 x 2" Full Thread Hex Head	F05007-16	1	
28	Spacer, Power Feed Motor	015136	4	
29	BOLT, 3/8-16 X 4 1/2" HEX HEAD	F05007-35	2	
30	WASHER, 10.5 FLAT	F81055-1	4	
31	NUT, 3/8-16 HEX NYLON LOCK	F05010-10	2	

7.3 Feed Chain/Stop, LT40 Series

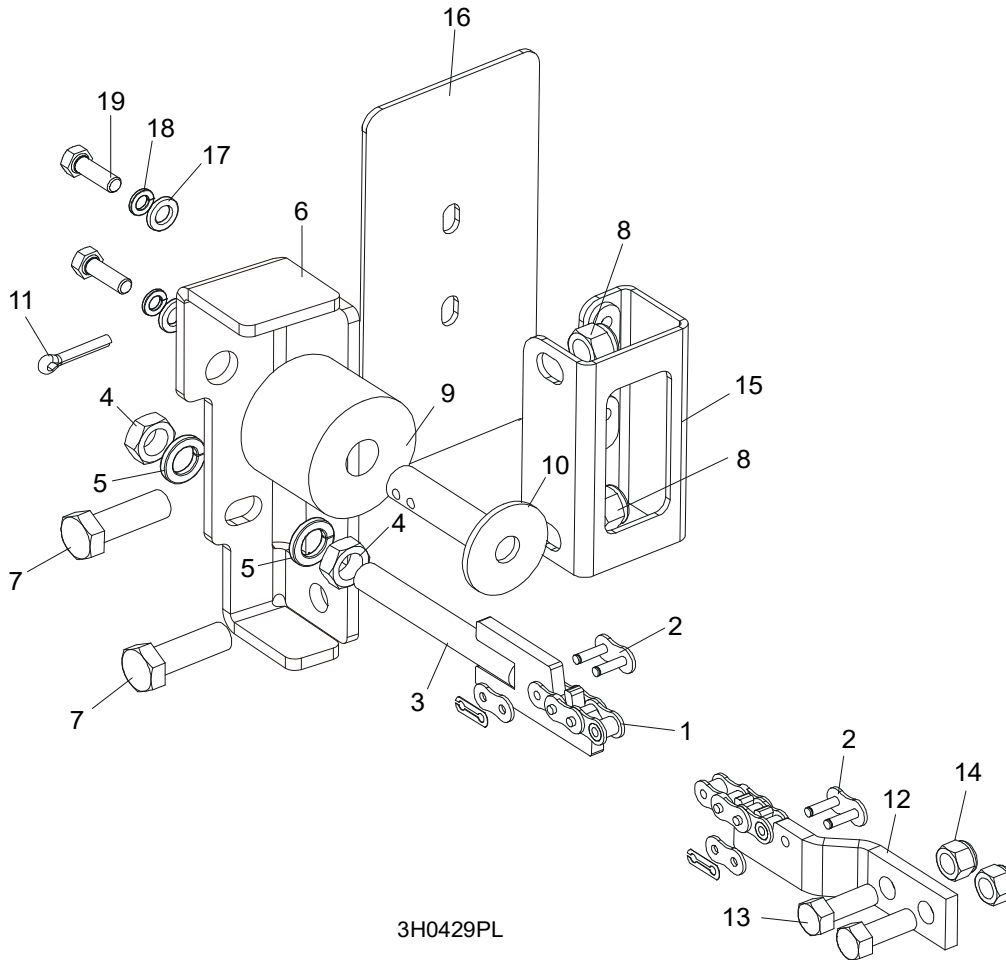

REF.	DESCRIPTION (◆ Indicates Parts Available In Assemblies Only)	PART #	QTY
	CHAIN KIT, LT40S FEED	K10408	1
	CHAIN KIT, LT40M FEED	K10410	1
1	Chain, #40 X 215" LT40S Feed	014744	1
	Chain, #40 X 267.5" LT40M Feed	014745	1
	Chain 0.9M #40 35.5"	521579	1
2	Link, #40 Master	P04200	2
3	Tensioner Weldment, Power Feed Chain	086818-1	1
4	Nut, M12-5 Hex Jam	F81034-4	2
5	Washer, 12.2 Split Lock	F81056-2	2
6	BRACKET, FEED CHAIN REAR MOUNT	087628-1	1
7	BOLT, M12 X 40 8.8 HEX HEAD FULL THREAD ZINC	F81004-4	2
8	NUT, M12-8 HEX NYLON LOCK	F81034-2	2
	STOP KIT, RUBBER CARRIAGE	K09630	2
9	Stop, Rubber Carriage	P12165	1
10	Pin, Rubber Carriage Stop	086182-1	1
11	Pin, 3/16" X 1" Cotter	F05012-21	1
12	BRACKET, FRONT FEED CHAIN MOUNT	095733-1	1
13	BOLT, M10x25 8.8 HEX HEAD	F81003-31	2

7 Power Feed & Track Rollers

Feed Chain/Stop, LT40 Series

14	NUT, M10-8-B HEX NYLON LOCK	F81033-1	2	
15	BRACKET WELDMENT, REAR MAIN TUBE COVER MOUNT	087105-1	1	
16	COVER, REAR MAIN TUBE	015023	1	
17	WASHER, 8.4 FLAT	F81054-1	2	
18	WASHER, 8.2 SPLIT LOCK	F81054-4	2	
19	BOLT, M8x25-8.8 HEX HEAD	F81002-5	2	

7.4 Lower Track Rollers

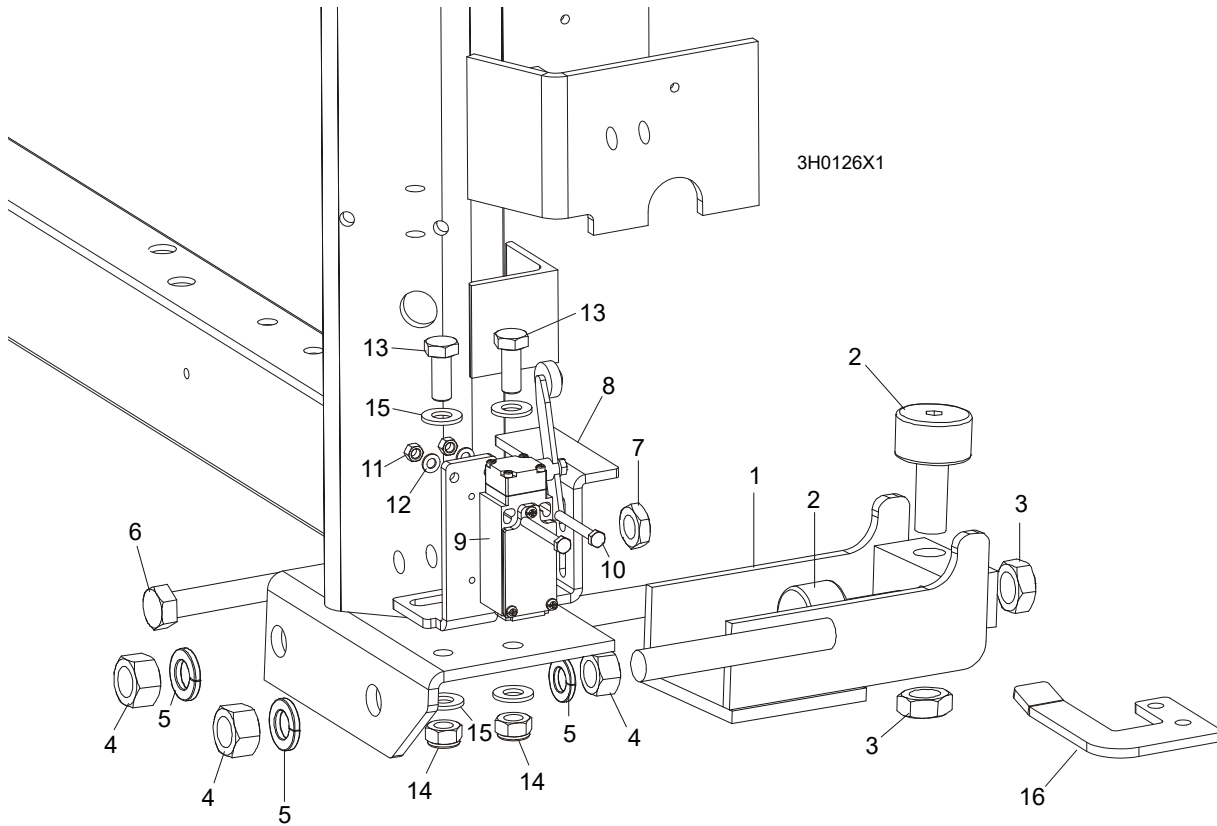

REF.	DESCRIPTION (◆ Indicates Parts Available In Assemblies Only)	PART #	QTY
	ROLLER ASSEMBLY, LOWER TRACK	098741	2
1	Bracket, Lower Track Roller Mounting	098740-1	1
2	Roller, Track Cam Bearing (McGill)	012797	2
3	Nut, 5/8-18 Hex Jam	F05010-11	2
4	Nut, M16-5.8 Hex Zinc	F81036-1	4
5	Washer, 16.3 Split Lock	F81058-2	4
6	BOLT, M12 X 55-8.8 HEX HEAD FULL THREAD	F81004-12	2
7	NUT, M12-8-B HEX ZINC	F81034-1	2
8	BRACKET, POWER SUPPLY STRIP AND LIMIT SWITCH	086380-1	1
9	SWITCH, GLCB01A2B LIMIT	086469	1
10	BOLT, M5 X 40 8.8 HEX HEAD	F81000-11	2
11	NUT, M5-8 HEX ZINC	F81030-1	2
12	WASHER, 5.3 FLAT	F81052-1	2
13	BOLT, M10 X 25 8.8 HEX HEAD FULL THREAD ZINC	F81003-11	2
14	NUT, M10-8-B HEX NYLON ZINC LOCK	F81033-1	2
15	WASHER, 10.5 FLAT	F81055-1	2
16	BRACKET, LIMIT SWITCH	091852-1	1

SECTION 8 BED FRAME ASSEMBLY

8.1 Bed Rail Assembly, Front (S/M Type Frame)

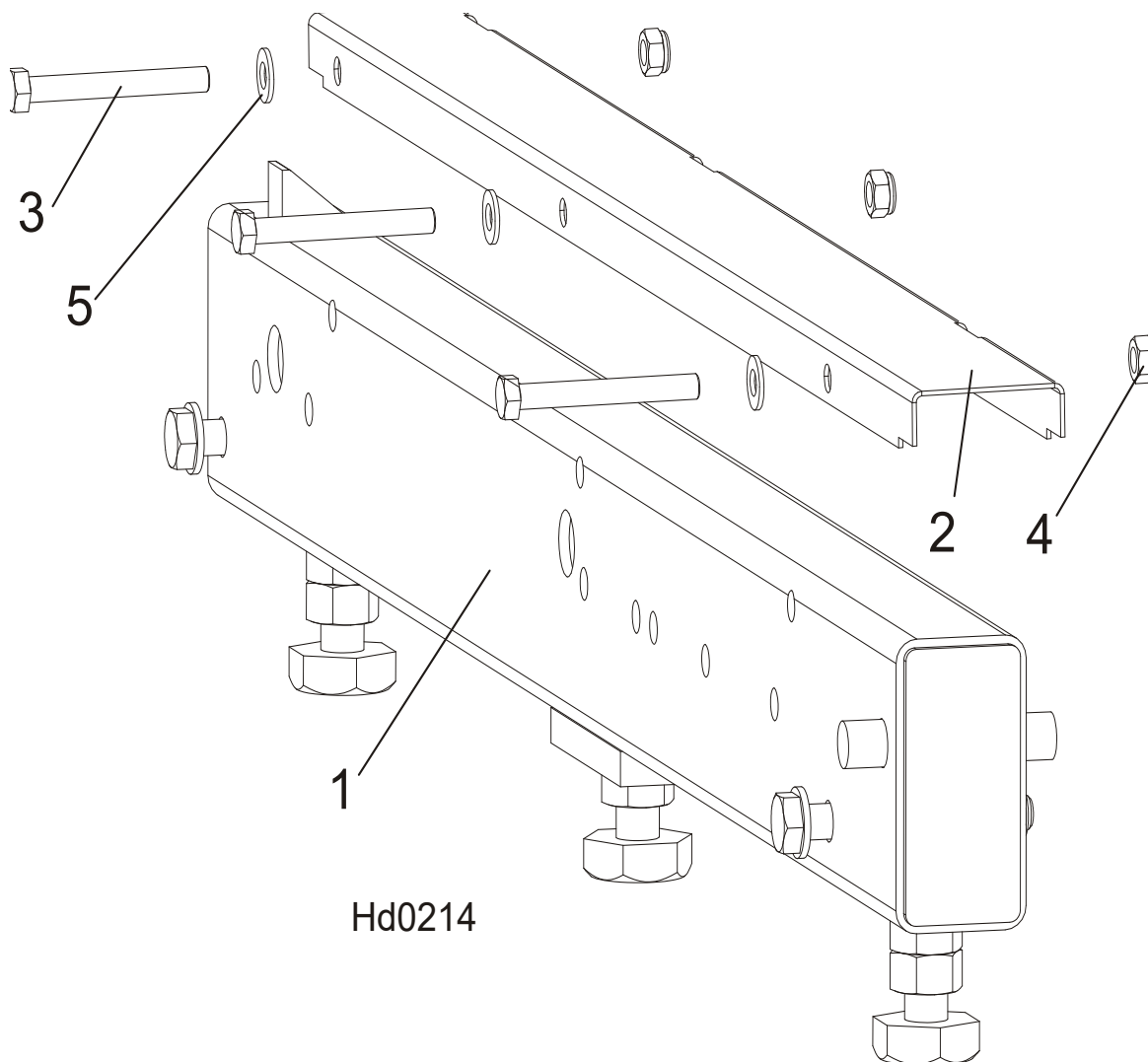

REF.	DESCRIPTION (◆ Indicates Parts Available In Assemblies Only)	PART #	QTY	
1	BED DRIVE ROLLER (S&M FRAME)	100676	1	
2	COVER, STAINLESS STEEL BED RAIL	099124	1	
3	BOLT, M8X65-5.8 ZINC HEX HEAD	F81002-3	3	
4	NUT, M8-8-B-ZINC HEX NYLON LOCK	F81032-2	3	
5	WASHER, 8.4 FLAT ZINC	F81054-1	3	

8.2 Bed Rail Assembly, Rear (S/M Type Frame)

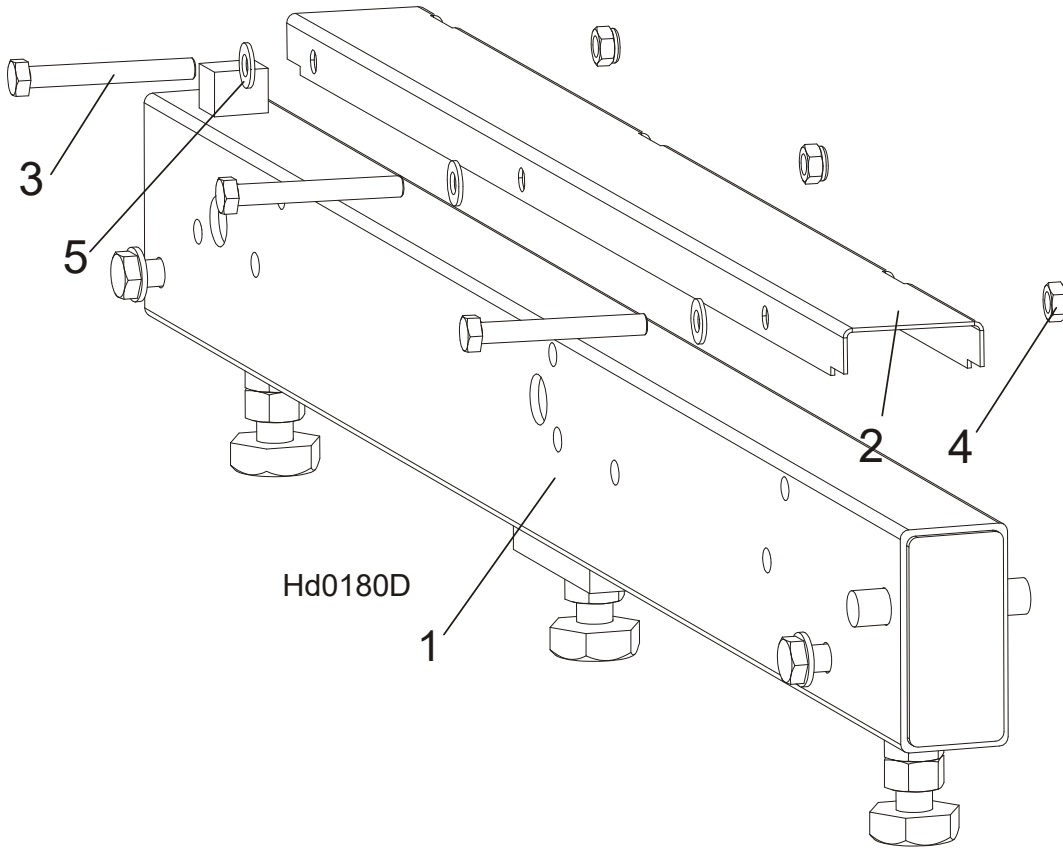

REF.	DESCRIPTION (◆ Indicates Parts Available In Assemblies Only)	PART #	QTY
1	BED RAIL ASSEMBLY, REAR PAINTED	091555	1
2	COVER, STAINLESS STEEL BED RAIL	099124	1
3	BOLT, M8X65-5.8 ZINC HEX HEAD	F81002-3	3
4	NUT, M8-8-B-ZINC HEX NYLON LOCK	F81032-2	3
5	WASHER, 8.4 FLAT ZINC	F81054-1	3

8 Bed Frame Assembly

Angled Bed Rail ("S" Type Frame)

8.3 Angled Bed Rail ("S" Type Frame)

532160_001
532160_MANUAL

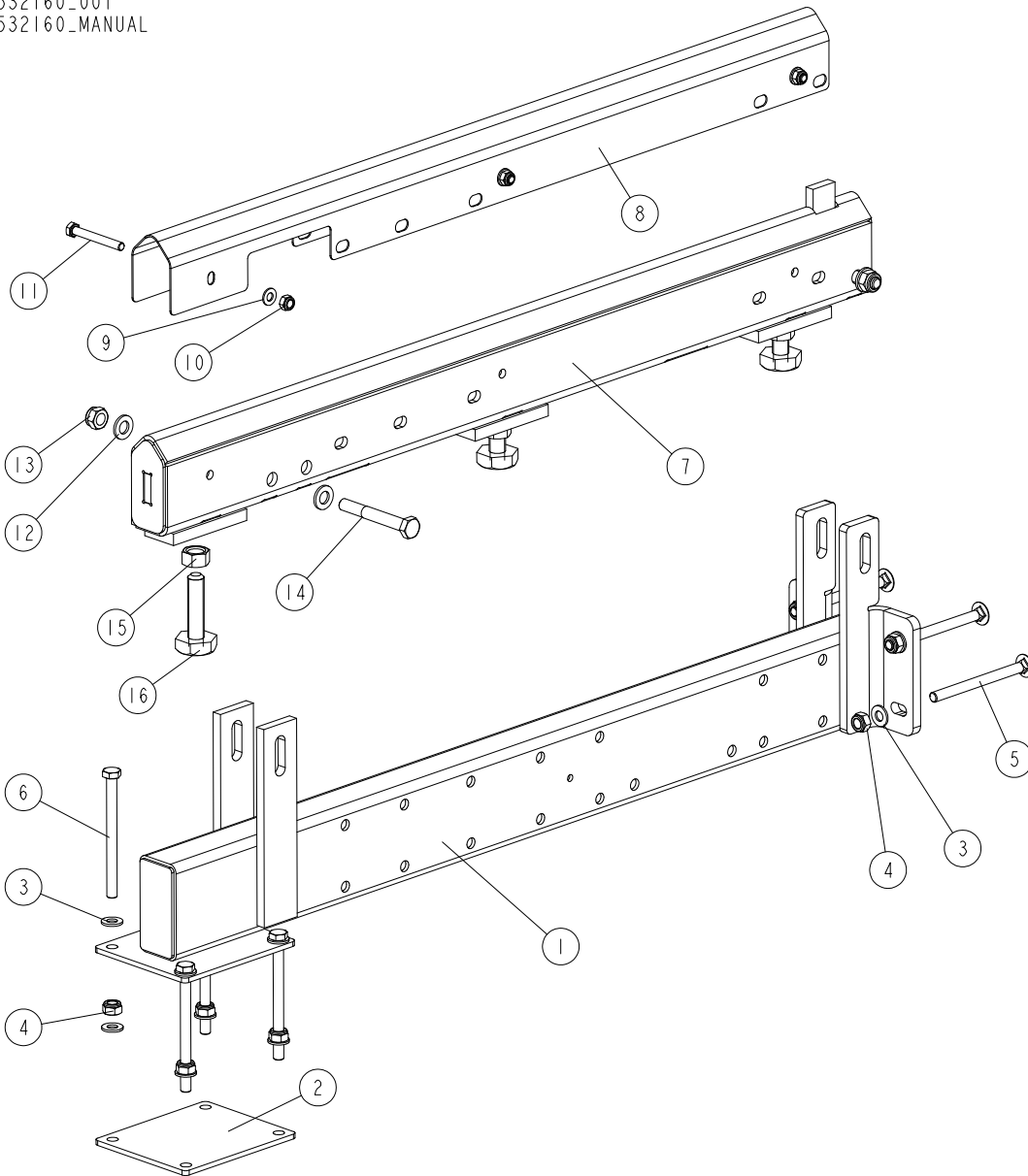

REF.	DESCRIPTION (◆ Indicates Parts Available In Assemblies Only)	PART #	QTY
-	RAIL, "S" TYPE FRAME ADDITIONAL ANGLED - COMPLETE	532160	1
1	TUBE, ADDITIONAL BED RAIL SUPPORT ("S" FRAME)	531249-1	1
2	PLATE, MOUNT	087055-1	1
3	WASHER, 10.5 FLAT ZINC	F81055-1	12
4	NUT, M10-8-B HEX NYLON ZINC LOCK	F81033-1	8
5	BOLT, M10X125 8.8 CARRIAGE ZINC	F81003-34	4
6	BOLT, M10X125 8.8 HEX HEAD ZINC	F81003-18	4
7	RAIL, ADJUSTABLE ANGLED	521930	1
8	COVER, BED RAIL ("M-SUPER" & "L" FRAMES)	522979	1
9	WASHER, 8.4 FLAT ZINC	F81054-1	3

Bed Frame Assembly

Angled Bed Rail ("S" Type Frame)

8

REF.	DESCRIPTION (◆ Indicates Parts Available In Assemblies Only)	PART #	QTY	
10	NUT, M8-8-B HEX NYLON ZINC LOCK	F81032-2	3	
11	BOLT, M8X65 8.8 HEX HEAD FULL THREAD ZINC	F81002-9	3	
12	WASHER, 13 FLAT ZINC	F81056-1	4	
13	NUT, M12 8 HEX NYLON ZINC LOCK	F81034-2	2	
14	BOLT, M12X90 8.8 HEX HEAD ZINC	F81004-2	2	
-	BOLT W/NUT (M16 BOLT & NUT)	516629	3	
15	NUT, M16 5.8 HEX	F81036-5	1	
16	BOLT, M16	505006	1	

8 Bed Frame Assembly

Bed Rail Assembly, Front Middle (S/M Type Frame)

8.4 Bed Rail Assembly, Front Middle (S/M Type Frame)

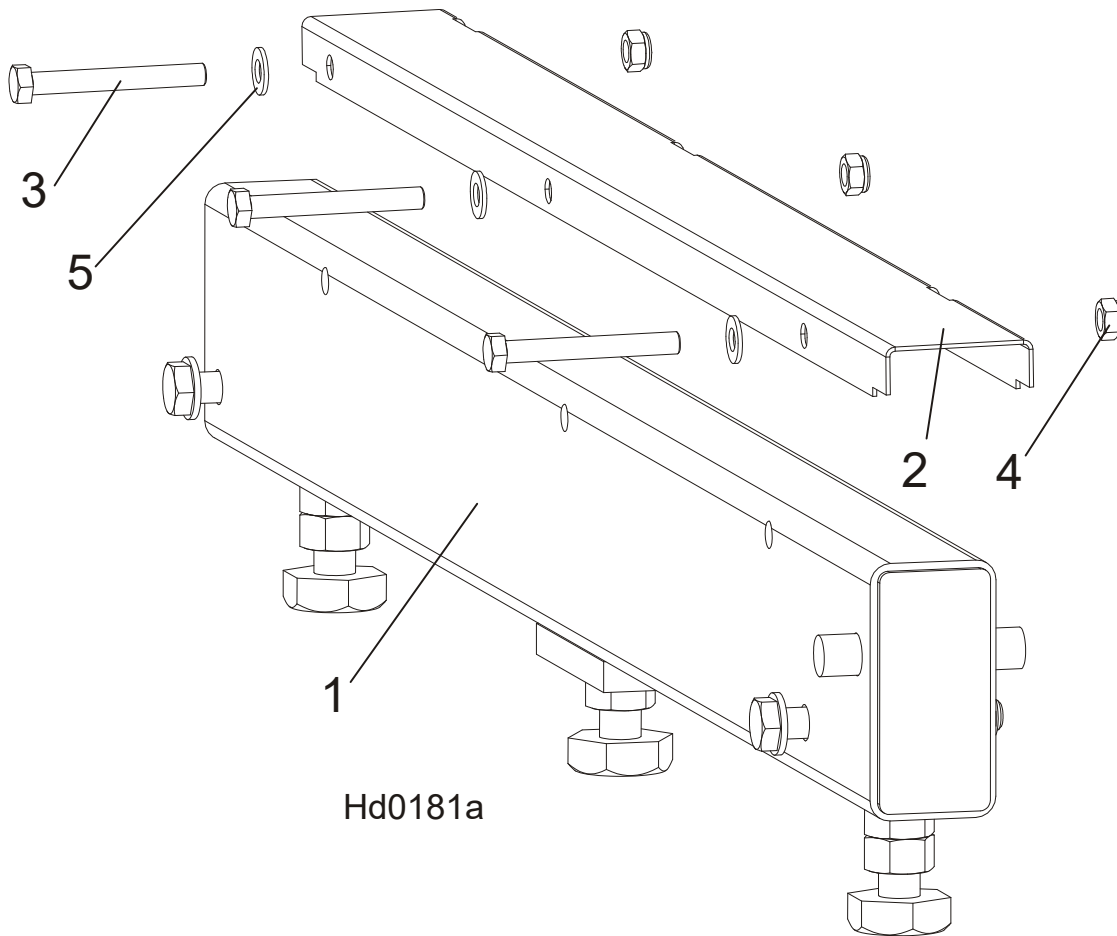

REF.	DESCRIPTION (◆ Indicates Parts Available In Assemblies Only)	PART #	QTY
1	BED RAIL ASSEMBLY, FRONT MIDDLE	091556	1
2	COVER, STAINLESS STEEL BED RAIL	099124	1
3	BOLT, M8X65-5.8 ZINC HEX HEAD	F81002-3	3
4	NUT, M8-8-B-ZINC HEX NYLON LOCK	F81032-2	3
5	WASHER, 8.4 FLAT ZINC	F81054-1	3

8.5 Bed Rail Assembly, Rear Middle

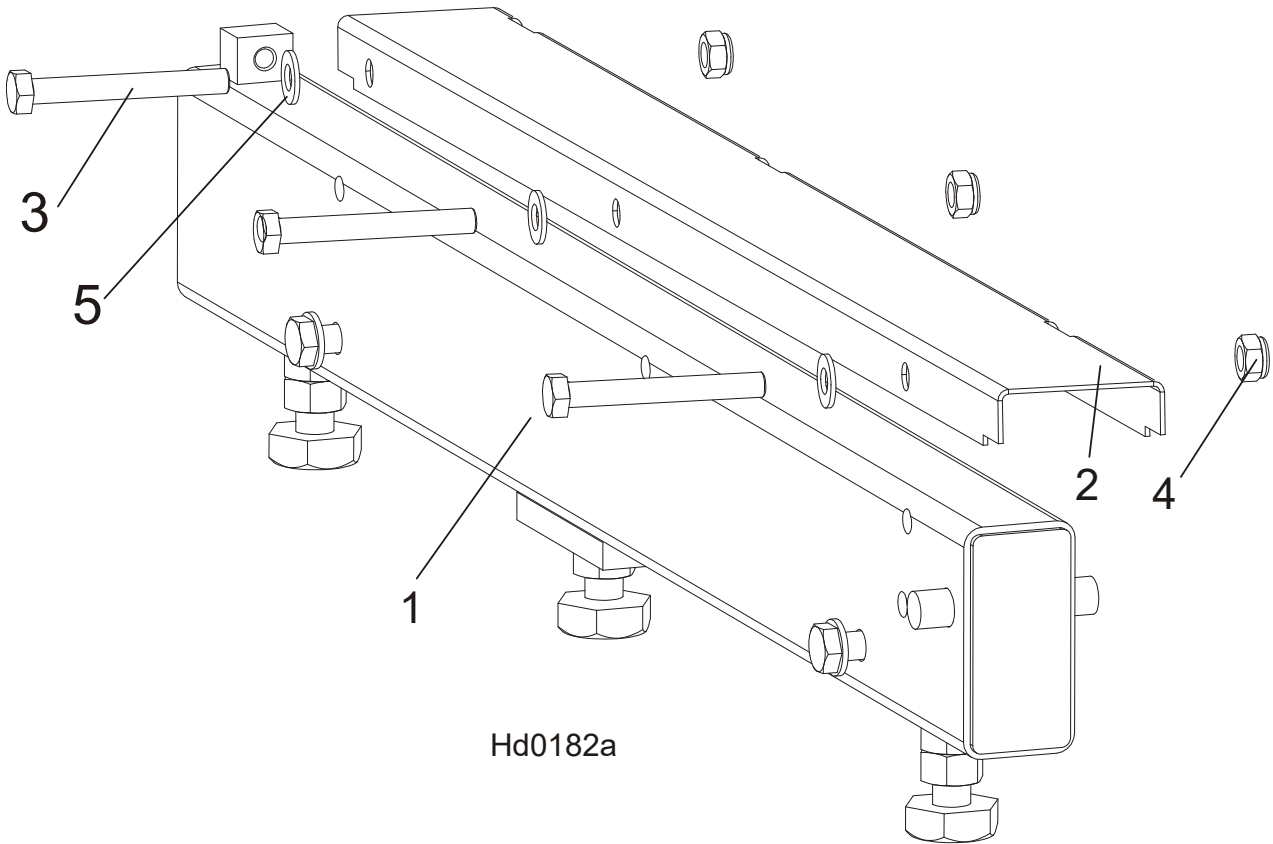

REF.	DESCRIPTION (◆ Indicates Parts Available In Assemblies Only)	PART #	QTY
1	BED RAIL ASSEMBLY, REAR MIDDLE	091557	1
2	COVER, STAINLESS STEEL BED RAIL	099124	1
3	BOLT, M8X65-5.8 ZINC HEX HEAD	F81002-3	3
4	NUT, M8-8-B-ZINC HEX NYLON LOCK	F81032-2	3
5	WASHER, 8.4 FLAT ZINC	F81054-1	3

8 Bed Frame Assembly

Additional Angled Bed Rail (Long)

8.6 Additional Angled Bed Rail (Long)

545592_001
545592_MANUAL

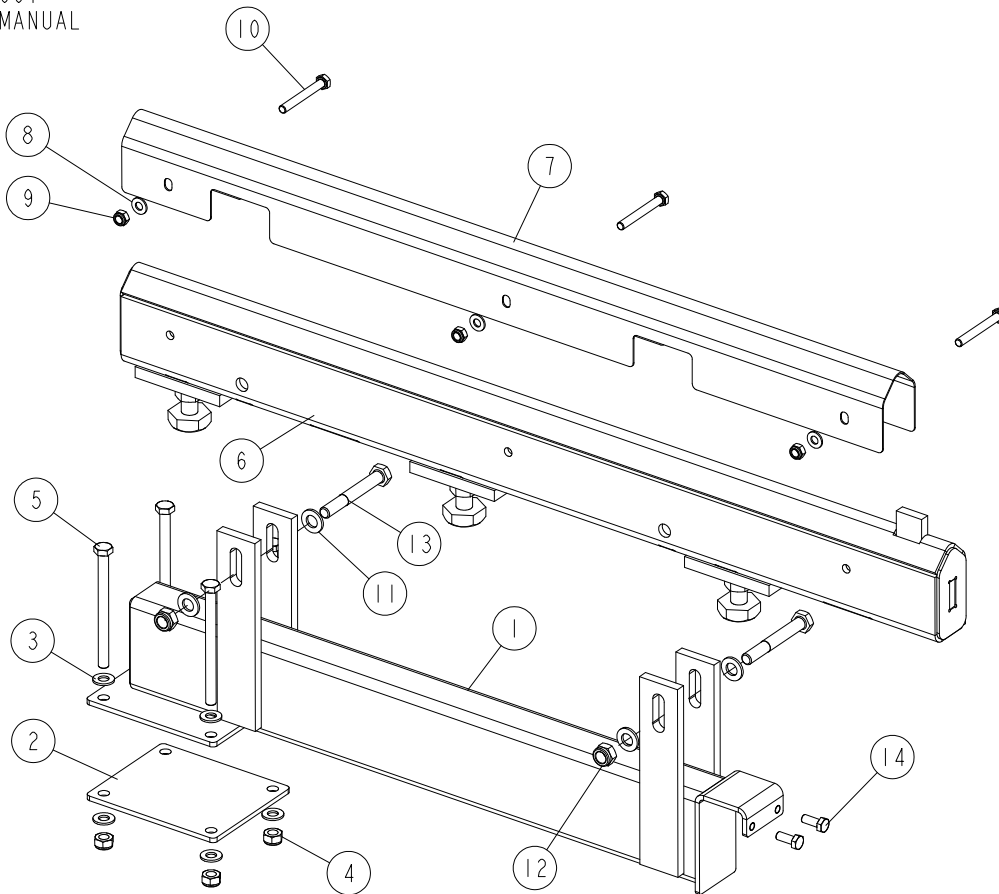

REF.	DESCRIPTION (◆ Indicates Parts Available In Assemblies Only)	PART #	QTY
-	ADDITIONAL ANGLED BED RAIL (LONG) - COMPLETE	545592	1
1	SUPPORT, ADDITIONAL BED RAIL	545591-1	1
2	PLATE, MOUNT	087055-1	1
3	WASHER, 10.5 FLAT ZINC	F81055-1	8
4	NUT, M10-8-B HEX NYLON ZINC LOCK	F81033-1	4
5	BOLT, M10X125 8.8 HEX HEAD ZINC	F81003-18	4
6	TUBE, ADDITIONAL BED RAIL	545589-1	1
7	COVER, ADDITIONAL BED RAIL	545594	1
8	WASHER, 8.4 FLAT ZINC	F81054-1	3
9	NUT, M8-8-B HEX NYLON ZINC LOCK	F81032-2	3
10	BOLT, M8X65 8.8 HEX HEAD FULL THREAD ZINC	F81002-9	3
11	WASHER, 13 FLAT ZINC	F81056-1	4
12	NUT, M12-8 DIN 982 HEX NYLON ZINC LOCK	F81034-2	2
13	BOLT, M12X90 8.8 HEX HEAD ZINC	F81004-2	2
14	BOLT, M8X20 8.8 HEX HEAD FULL THREAD ZINC	F81002-4	2

8.7 Additional Flat Bed Rail (Long)

545597_001
545597_MANUAL

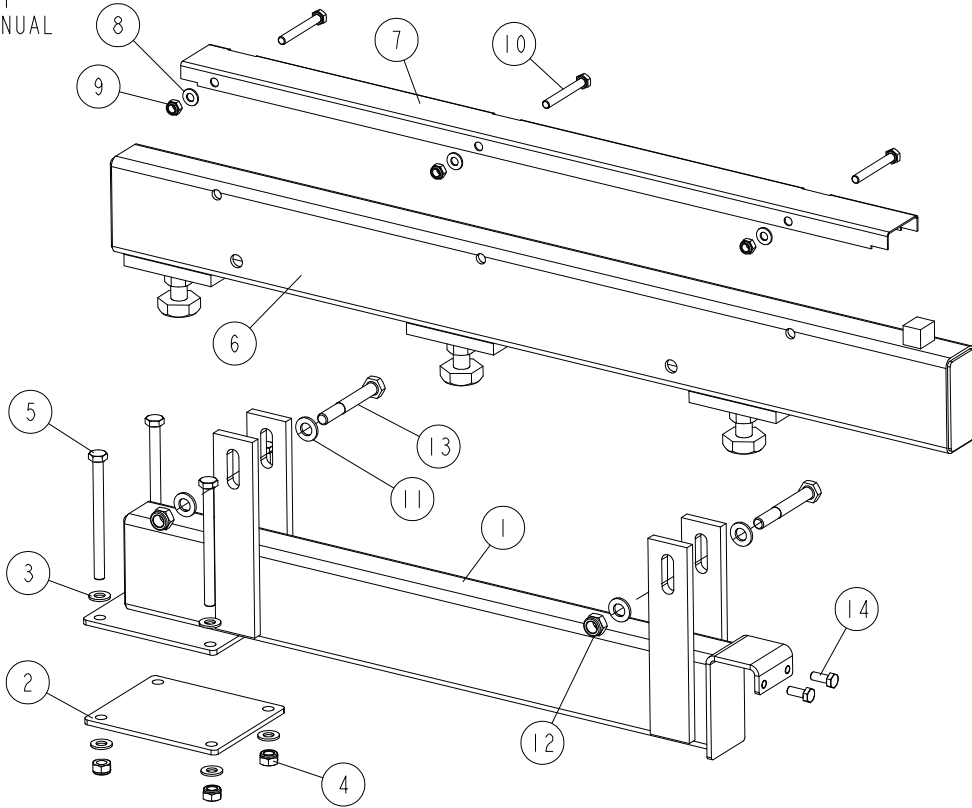

REF.	DESCRIPTION (◆ Indicates Parts Available In Assemblies Only)	PART #	QTY
-	ADDITIONAL FLAT BED RAIL (LONG) - COMPLETE	545597	1
1	SUPPORT, ADDITIONAL BED RAIL	545591-1	1
2	PLATE, MOUNT	087055-1	1
3	WASHER, 10.5 FLAT ZINC	F81055-1	8
4	NUT, M10-8-B HEX NYLON ZINC LOCK	F81033-1	4
5	BOLT, M10X125 8.8 HEX HEAD ZINC	F81003-18	4
6	TUBE, ADDITIONAL BED RAIL	545595-1	1
7	COVER, BED RAIL	099124	1
8	WASHER, 8.4 FLAT ZINC	F81054-1	3
9	NUT, M8-8-B HEX NYLON ZINC LOCK	F81032-2	3
10	BOLT, M8X65 8.8 HEX HEAD FULL THREAD ZINC	F81002-9	3
11	WASHER, 13 FLAT ZINC	F81056-1	4
12	NUT, M12-8 DIN 982 HEX NYLON ZINC LOCK	F81034-2	2
13	BOLT, M12X90 8.8 HEX HEAD ZINC	F81004-2	2
14	BOLT, M8X20 8.8 HEX HEAD FULL THREAD ZINC	F81002-4	2

8 Bed Frame Assembly

Additional Flat Bed Rail (Short)

8.8 Additional Flat Bed Rail (Short)

545645_001
545645_MANUAL

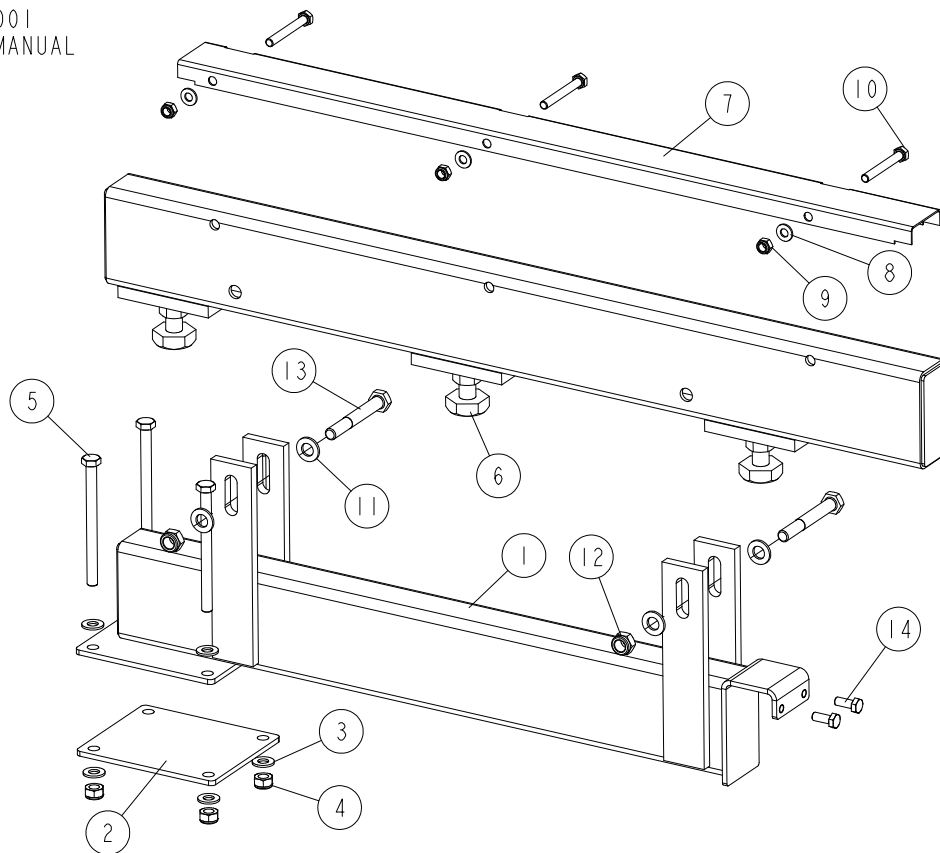

REF.	DESCRIPTION (◆ Indicates Parts Available In Assemblies Only)	PART #	QTY
-	ADDITIONAL FLAT BED RAIL (SHORT) - COMPLETE	545645	1
1	SUPPORT, ADDITIONAL BED RAIL	545591-1	1
2	PLATE, MOUNT	087055-1	1
3	WASHER, 10.5 FLAT ZINC	F81055-1	8
4	NUT, M10-8-B HEX NYLON ZINC LOCK	F81033-1	4
5	BOLT, M10X125 8.8 HEX HEAD ZINC	F81003-18	4
6	TUBE, ADDITIONAL BED RAIL	545643-1	1
7	COVER, BED RAIL	099124	1
8	WASHER, 8.4 FLAT ZINC	F81054-1	3
9	NUT, M8-8-B HEX NYLON ZINC LOCK	F81032-2	3
10	BOLT, M8X65 8.8 HEX HEAD FULL THREAD ZINC	F81002-9	3
11	WASHER, 13 FLAT ZINC	F81056-1	4
12	NUT, M12-8 DIN 982 HEX NYLON ZINC LOCK	F81034-2	2
13	BOLT, M12X90 8.8 HEX HEAD ZINC	F81004-2	2
14	BOLT, M8X20 8.8 HEX HEAD FULL THREAD ZINC	F81002-4	2

8.9 Additional Angled Bed Rail (Short)

545632_001
545632_MANUAL

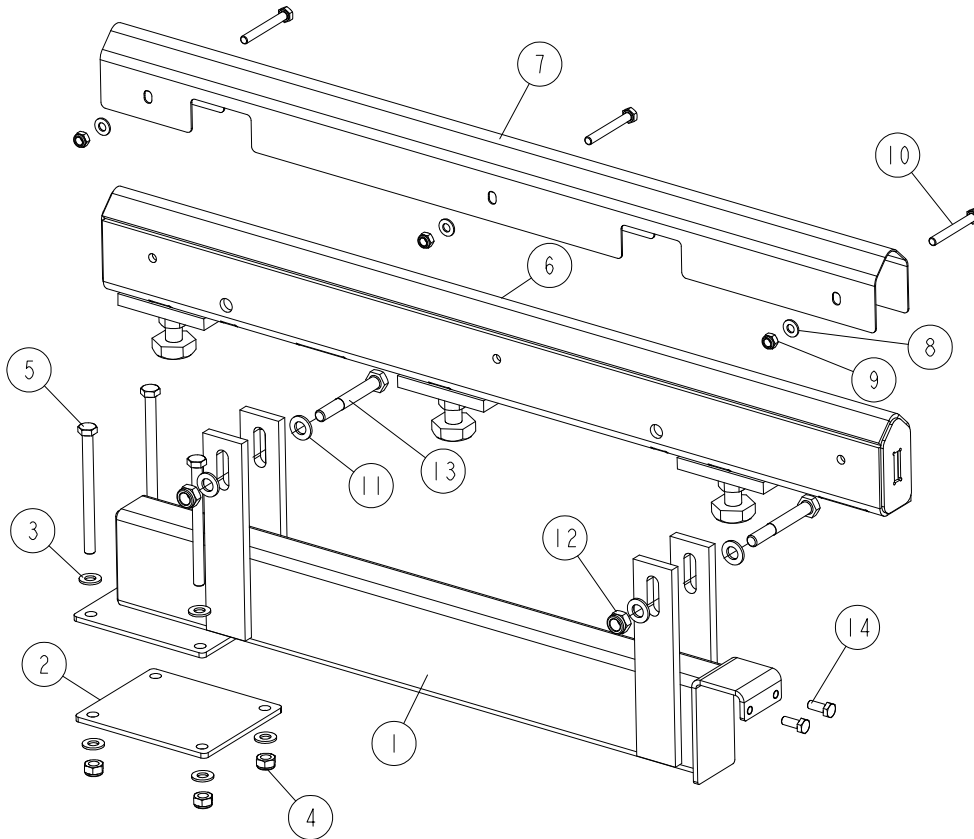

REF.	DESCRIPTION (◆ Indicates Parts Available In Assemblies Only)	PART #	QTY
-	ADDITIONAL ANGLED BED RAIL (SHORT) - COMPLETE	545632	1
1	SUPPORT, ADDITIONAL BED RAIL	545591-1	1
2	PLATE, MOUNT	087055-1	1
3	WASHER, 10.5 FLAT ZINC	F81055-1	8
4	NUT, M10-8-B HEX NYLON ZINC LOCK	F81033-1	4
5	BOLT, M10X125 8.8 HEX HEAD ZINC	F81003-18	4
6	TUBE, ADDITIONAL BED RAIL	545630-1	1
7	COVER, ADDITIONAL BED RAIL	545594	1
8	WASHER, 8.4 FLAT ZINC	F81054-1	3
9	NUT, M8-8-B HEX NYLON ZINC LOCK	F81032-2	3
10	BOLT, M8X65 8.8 HEX HEAD FULL THREAD ZINC	F81002-9	3
11	WASHER, 13 FLAT ZINC	F81056-1	4
12	NUT, M12-8 DIN 982 HEX NYLON ZINC LOCK	F81034-2	2
13	BOLT, M12X90 8.8 HEX HEAD ZINC	F81004-2	2
14	BOLT, M8X20 8.8 HEX HEAD FULL THREAD ZINC	F81002-4	2
REF	DESCRIPTION (u indicates parts available in assemblies only)	PART #	QTY
-	CLAMP MOUNT ASSEMBLY - FRONT	092937	1
1	BED RAIL ASSEMBLY, FRONT	092903-1	1
2	RAIL, AH5/DH5 BED	095131-1	1
3	TUBE WELDMENT, BED FRONT	092904-1	1



Bed Frame Assembly

Additional Angled Bed Rail (Short)

REF	DESCRIPTION (u indicates parts available in assemblies only)	PART #	QTY	
4	WASHER 10,5 ZC DIN 126 ISO 7091	F81055-1	20	
5	NUT, M10-8-B HEX NYLON ZINC LOCK	F81033-1	12	
6	BOLT, M10X75-8.8 HEX HEAD ZINC	F81003-15	4	
7	BOLT, M10-1.5X25MM HH GR8.8	F81003-11	4	
8	BOLT, M10X125 8.8 CARRIAGE ZINC	F81003-34	4	
9	COVER, PIVOT BED RAIL	099123	1	
10	BOLT, M8X65 5.8-HEX HEAD ZINC	F81002-3	2	
11	NUT, M8 8 HEX NYLON ZINC LOCK	F81032-2	2	
12	PLATE, 1/4 HOSE CLAMP	S09245	2	
13	BOLT, 5/16-18 X 3/4 SELF-TAPPING	F05015-30	2	
14	BUSHING, ZINC-PLATED SPACER	095427-1	4	
15	LEG, LEFT STATIONARY ADJUSTABLE	501639	1	

8.10 Bed Extension LT40 (0.9m) - Complete

540139_40_001_B
 540139_40_MANUAL

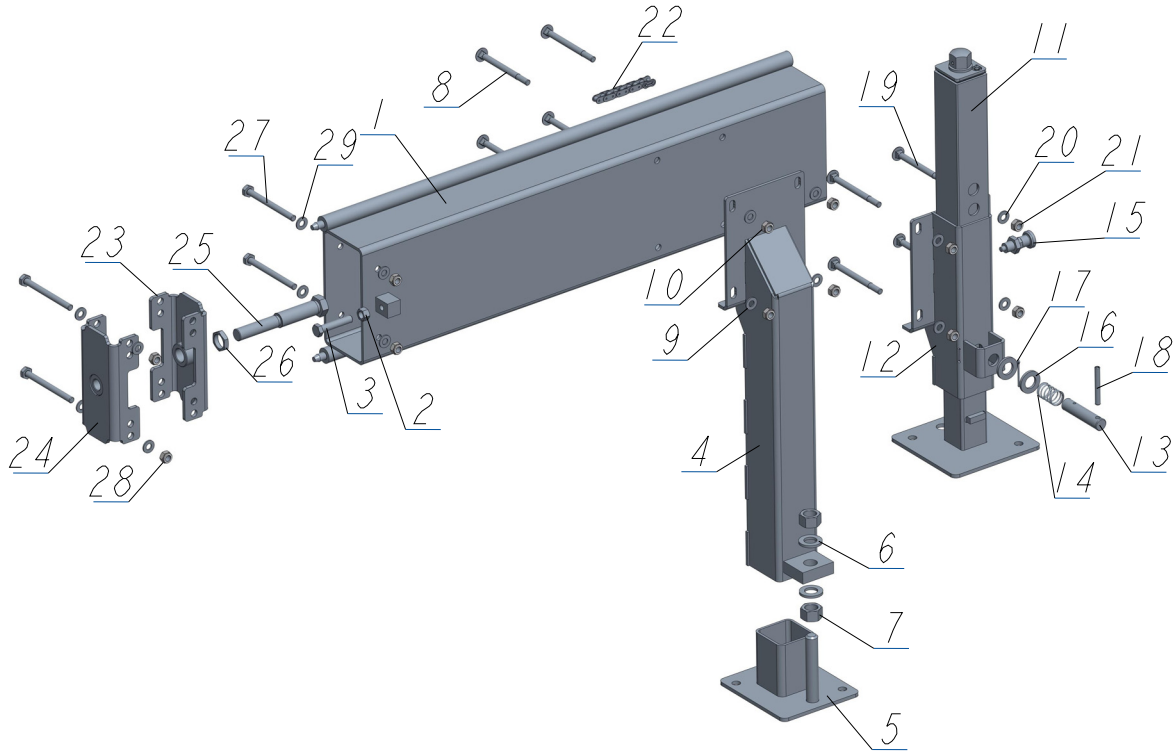

REF	DESCRIPTION (u indicates parts available in assemblies only)	PART #	QTY
-	EXTENSION, BED LT40 (0.9M)- COMPLETE	540139-40	1
1	TUBE WELDMENT, 0.9M W/RODS	540138-1	1
2	NUT, M12-8 ZINC	F81034-1	1
3	BOLT M12X60-8 HEX HEAD FULL THREAD ZINC	F81004-51	1
-	LEG, RIGHT ADJUSTABLE STATIONARY	501640	1
4	LEG, MAIN TUBE (HIGH)	507620-1	1
5	FOOT	586948-1	1
6	WASHER, 21 FLAT ZINC	F81059-2	2
7	NUT, M20-8 HEX ZINC	F81037-1	2
8	BOLT, M10X120 8.8 CARRIAGE ZINC	F81003-33	4
9	WASHER, 10.5 FLAT ZINC	F81055-1	4
10	NUT, M10-8-B NYLON HEX ZINC LOCK	F81033-1	4
-	LEG, COMPLETE FINE ADJUST OUTRIGGER	094584	1
11	FINE ADJUST OUTRIGGER LEG	093589	1
12	GUIDE, FINE ADJUST OUTRIGGER LEG	506114-1	1
13	PIN, OUTRIGGER PULL	087012-1	1
14	SPRING, ZINC	087040	1
15	PIN, DETENT	090197	1
16	WASHER, 21 FLAT ZINC	F81059-2	2
17	PIN, S-ZN 4X25 COTTER	F81043-2	1
18	PIN 8X65 ROLL	F81046-1	1
19	BOLT, M10X120 8.8 CARRIAGE ZINC	F81003-33	4

Bed Frame Assembly**Bed Extension LT40 (0.9m) - Complete**

REF	DESCRIPTION (u indicates parts available in assemblies only)	PART #	QTY	
20	WASHER, 10.5 FLAT ZINC	F81055-1	4	
21	NUT, M10-8-B NYLON HEX ZINC LOCK	F81033-1	4	
22	CHAIN, 0.9M LT40	540146	1	
-	BRACE KIT BX	501340	1	
23	CONNECTOR, BX (M24) - WLDMT/PTD	500989-1	1	
24	CONNECTOR, BX (M20) - WLDMT/PTD.	501339-1	1	
25	BOLT, ZINC SPECIAL	087188-1	1	
26	NUT, M24X2 ZINC SPECIAL	087626-1	1	
27	BOLT, M10 X 115-8.8 HEX HEAD ZINC	F81003-19	4	
28	NUT, M10-8-B NYLON HEX ZINC LOCK	F81033-1	4	
29	WASHER, 10.5 FLAT ZINC	F81055-1	8	

8.11 Fine Adjust Outrigger Leg

093589_001_A
 093589_MANUAL

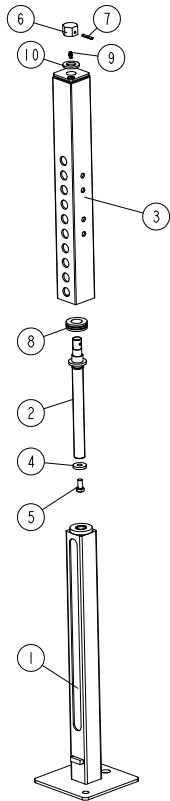

REF.	DESCRIPTION (* Indicates Parts Available in Assemblies Only)	PART #	QTY	
-	FINE ADJUST OUTRIGGER LEG	093589	1	
1	MIDDLE PART, FINE ADJUST OUTRIGGER LEG	093596-1	1	
2	BOLT, OUTRIGGER LEG	093590-1	1	
3	UPPER PART, FINE ADJUST OUTRIGGER LEG	093593-1	1	
4	WASHER 10.5/30-5	505156-1	1	
5	BOLT, M10x20-5 8 HEX HEAD FULL THREAD ZINC	F81003-1	1	
6	FITTING, M20 X 2,5	094408	1	
7	PIN 5X30 ROLL	F81044-21	1	
8	BEARING, 51205 THRUST	516599	1	
9	FITTING, M6 TYPE A STRAIGHT GREASE	086280	1	
10	WASHER, M21 FLAT ZINC	F81059-2	1	

REF	DESCRIPTION (u indicates parts available in assemblies only)	PART #	QTY	
-	CLAMP MOUNT ASSEMBLY - REAR	092938	1	

REF	DESCRIPTION (u indicates parts available in assemblies only)	PART #	QTY	
1	BED RAIL ASSEMBLY, REAR	092902-1	1	
2	RAIL, AH5/DH5 BED	095131-1	1	
3	TUBE WELDMENT, BED REAR	092907-1	1	
-	LEG, LEFT STATIONARY ADJUSTABLE	501639	1	
4	TUBE WELDMENT, ADJUSTABLE LEG	507715-1	1	
5	WASHER 10,5 ZC DIN 126 ISO 7091	F81055-1	4	
6	NUT, M10-8-B HEX NYLON ZINC LOCK	F81033-1	4	
7	WASHER 10,5 ZC DIN 126 ISO 7091	F81055-1	20	
8	NUT, M10-8-B HEX NYLON ZINC LOCK	F81033-1	12	
9	BOLT, M10-1.5X25MM HH GR8.8	F81003-11	8	
10	BOLT, M10X35-8.8 HEX HEAD FULL THREAD ZIN	F81003-17	4	
11	BOLT, M10X125 8.8 CARRIAGE ZINC	F81003-34	4	
12	COVER, PIVOT BED RAIL	099123	1	
13	BOLT, M8X65 5.8-HEX HEAD ZINC	F81002-3	2	
14	NUT, M8 8 HEX NYLON ZINC LOCK	F81032-2	2	
15	PLATE, 1/4 HOSE CLAMP	S09245	2	
16	BOLT, 5/16-18 X 3/4 SELF-TAPPING	F05015-30	2	

8.12 Adjustable Legs

528380_001
528380_MANUAL

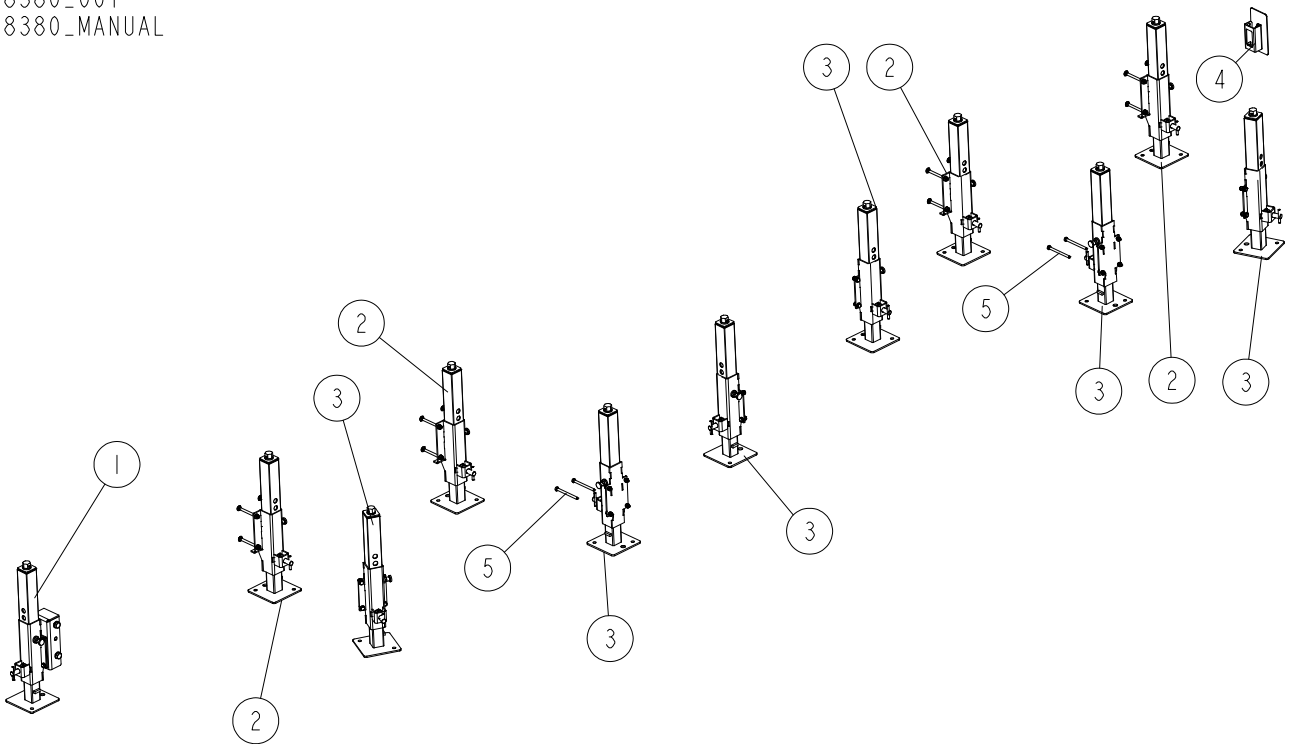

REF.	DESCRIPTION (◆ Indicates Parts Available In Assemblies Only)	PART #	QTY	
-	LEG SET, ADJUSTABLE ("M" HYDRAULIC FRAME)	528380	1	
1	LEG, COMPLETE ADJUSTABLE (AT HITCH)	528370	1	
2	LEG, MAIN TUBE - COMPLETE	094584	4	
3	LEG, COMPLETE SIDE	094583	6	
4	COVER ASSEMBLY, MAIN TUBE (STATIONARY MACHINES)	093052	1	
5	BOLT, M10X125 8.8 HEX HEAD ZINC	F81003-18	4	

8 Bed Frame Assembly

Adjustable legs (M Frame)

8.13 Adjustable legs (M Frame)

550461_001
550461_001

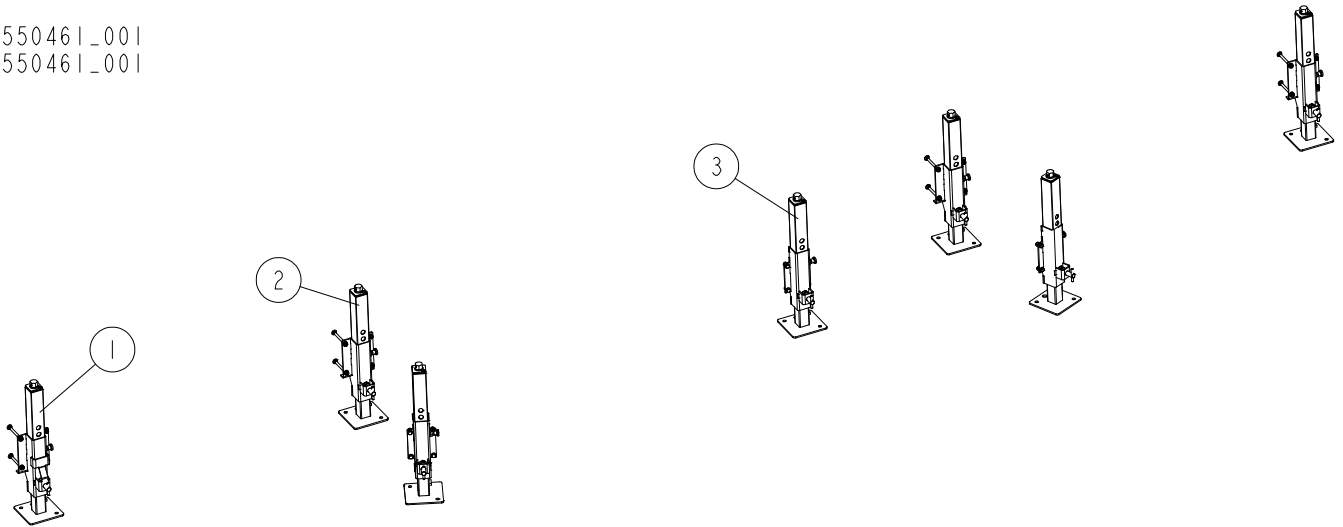

REF.	DESCRIPTION (◆ Indicates Parts Available In Assemblies Only)	PART #	QTY
-	ADJUSTABLE LEGS ASSEMBLY (M FRAME)	550461	1
1	LEG, BOARD RETURN TABLE - COMPLETE	550464	1
2	LEG, FINE ADJUST OUTRIGGER COMPLETE	094584	3
3	LEG, COMPLETE SIDE	094583	3

8.14 Complete Adjustable Leg (at hitch)

528370_001
 528370_MANUAL

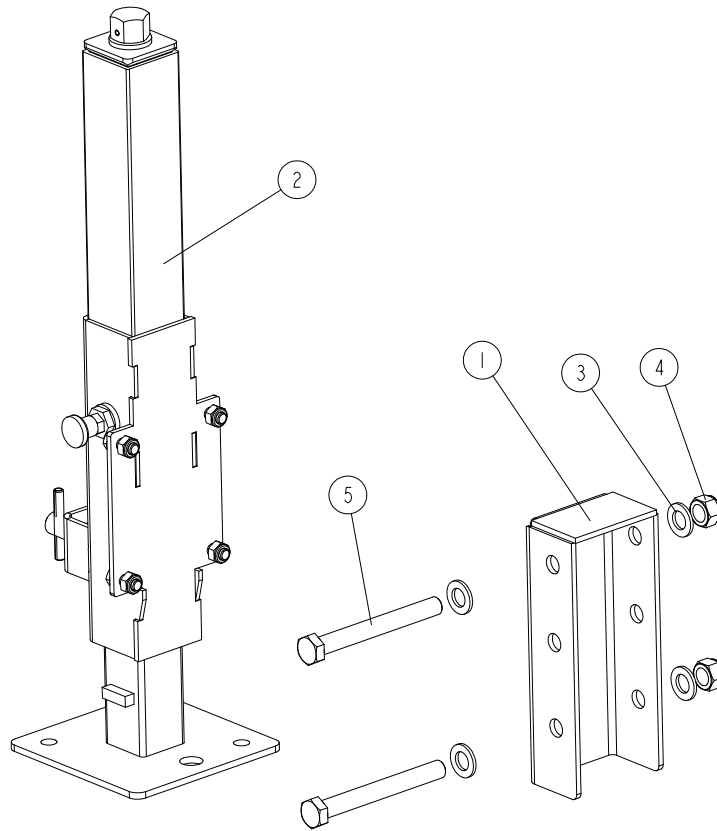

REF.	DESCRIPTION (◆ Indicates Parts Available In Assemblies Only)	PART #	QTY
-	LEG, FRONT ADJUSTABLE - COMPLETE	528370	1
1	BRACKET, LEG MOUNT	528368-1	1
2	LEG, COMPLETE SIDE	094583	1
3	WASHER, 17 SPLIT LOCK ZINC	F81058-1	4
4	NUT, M16-8 HEX NYLON ZINC LOCK	F81036-2	2
5	BOLT, M16X140 HEX HEAD ZINC	F81006-4	2

8.15 Board Return Table Leg - Complete

550461_002
550461_MANUAL

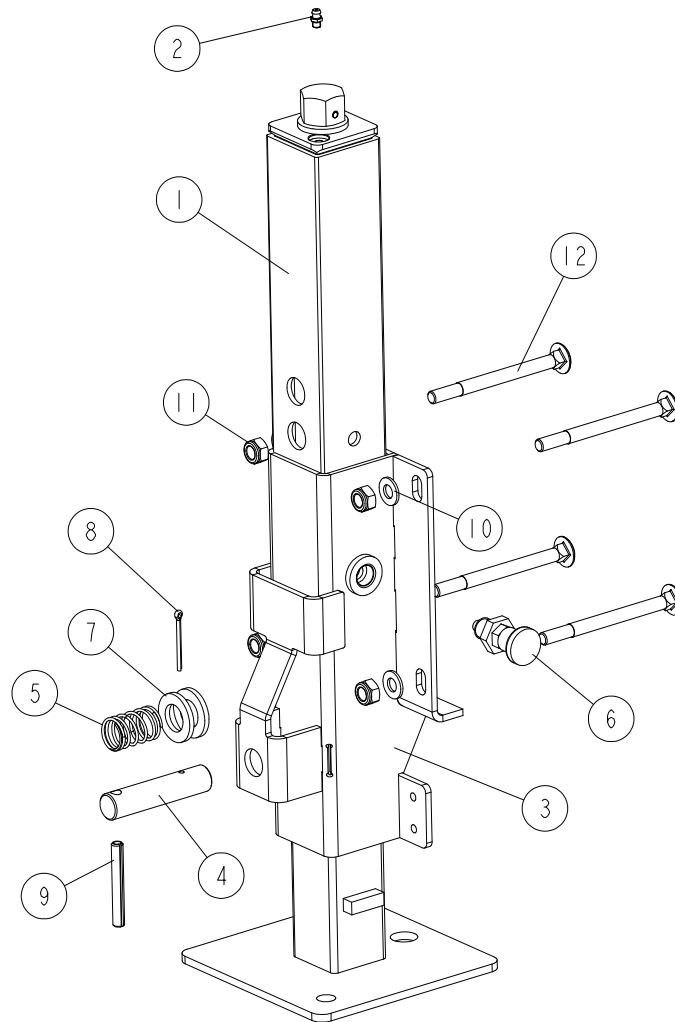

REF.	DESCRIPTION (◆ Indicates Parts Available In Assemblies Only)	PART #	QTY
-	LEG, BOARD RETURN TABLE - COMPLETE	550464	1
1	BASE WELDMENT, FINE ADJUST OUTRIGGER LEG	093589	1
2	FITTING, M6 WG. GREASE	086280	1
3	GUIDE, OUTRIGGER LEG	506116-1	1
4	PIN, 20X90 ZINC	087012-1	1
5	SPRING, 21X38X2, ZINC-PLATED	087040	1
6	PIN, 817-8-8-C-NI DETENT	090197	1
7	WASHER, 21 FLAT ZINC	F81059-2	2
8	PIN, S-ZN 4X25 COTTER	F81043-2	1
9	PIN, 8X65 SPRING ZINC-PLATED	F81046-1	1
10	WASHER, 10,5 FLAT ZINC	F81055-1	4
11	NUT, M10 HEX NYLON ZINC LOCK	F81033-1	4
12	NUT, M10X120 8.8 CARRIAGE ZINC	F81003-33	4

8.16 Angled Bed Rails, "M" Frame

524332_001
524332_MANUAL

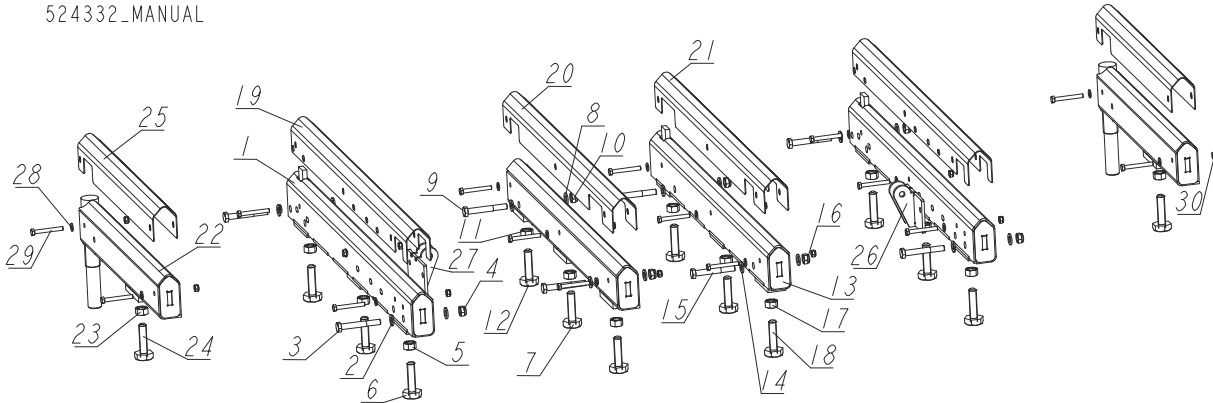

REF.	DESCRIPTION (◆ Indicates Parts Available In Assemblies Only)	PART #	QTY
-	RAIL SET, ANGLED BED - "M" FRAME	524332	1
1	RAIL, BED ADJUSTABLE (1 & 4)	520978-1	2
2	WASHER, 13 FLAT ZINC	F81056-1	4
3	BOLT, M12X90 8.8 HEX HEAD ZINC	F81004-2	2
4	NUT, M12 8 HEX NYLON ZINC LOCK	F81034-2	2
-	M16 BOLT & NUT	516629	3
5	NUT, M16 5.8 HEX	F81036-5	1
6	BOLT, M16	505006	1
7	RAIL, BED ADJUSTABLE L=849	520970-1	1
8	WASHER, 13 FLAT ZINC	F81056-1	4
9	BOLT, M12X90 8.8 HEX HEAD ZINC	F81004-2	2
10	NUT, M12 8 HEX NYLON ZINC LOCK	F81034-2	2
-	M16 BOLT & NUT	516629	3
11	NUT, M16 5.8 HEX	F81036-5	1
12	BOLT, M16	505006	1
13	RAIL, BED ADJUSTABLE (3)	520974-1	1
14	WASHER, 13 FLAT ZINC	F81056-1	4
15	BOLT, M12X90 8.8 HEX HEAD ZINC	F81004-2	2
16	NUT, M12 8 HEX NYLON ZINC LOCK	F81034-2	2
-	M16 BOLT & NUT	516629	3
17	NUT, M16 5.8 HEX	F81036-5	1
18	BOLT, M16	505006	1
19	COVER, BED RAIL	520903	2
20	COVER, MIDDLE BED RAIL - LEFT	521598	1
21	COVER, MIDDLE BED RAIL - RIGHT	521597	1
22	RAIL, BED PIVOT	521595-1	2
-	M16 BOLT W/2 NUTS	093710	1
23	NUT, M16 5.8 HEX	F81036-5	2
24	BOLT, M16	505006	1
25	COVER, M & S FRAME BED RAIL	520355	2
26	BRACKET, ROLLER MOUNT - LEFT	524350-1	1



Bed Frame Assembly

Angled Bed Rails, "M" Frame

REF.	DESCRIPTION (◆ Indicates Parts Available In Assemblies Only)	PART #	QTY	
27	BRACKET, ROLLER MOUNT - RIGHT	524348-1	1	
28	WASHER, 8.4 FLAT ZINC	F81054-1	16	
29	BOLT, M8X65 5.8 HEX HEAD ZINC	F81002-3	16	
30	NUT, M8-8-B HEX NYLON ZINC LOCK	F81032-2	16	

8.17 Plate Set, M Type Frame Bed Rail 1-2 & 2-3 (Option)

525065_001
525065_MANUAL

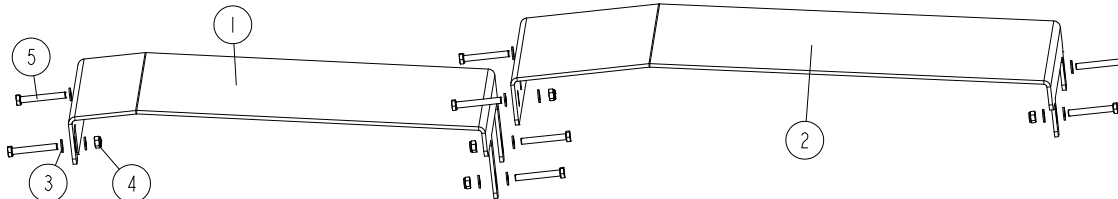

REF.	DESCRIPTION (◆ Indicates Parts Available in Assemblies Only)	PART#	QTY
-	PLATE SET, M TYPE FRAME BED RAIL 1-2 & 2-3	525065	1
1	TABLE PLATE, BED RAIL 1-2	525064-1	1
2	TABLE PLATE, BED RAIL 2-3	523804-1	1
3	WASHER, 10.5 FLAT ZINC	F81055-1	16
4	NUT, M10-8-B HEX NYLON ZINC LOCK	F81033-1	8
5	BOLT, M10X75-8.8-FE/ZN5 PN-M/82101	F81003-15	8

8.18 Long Table

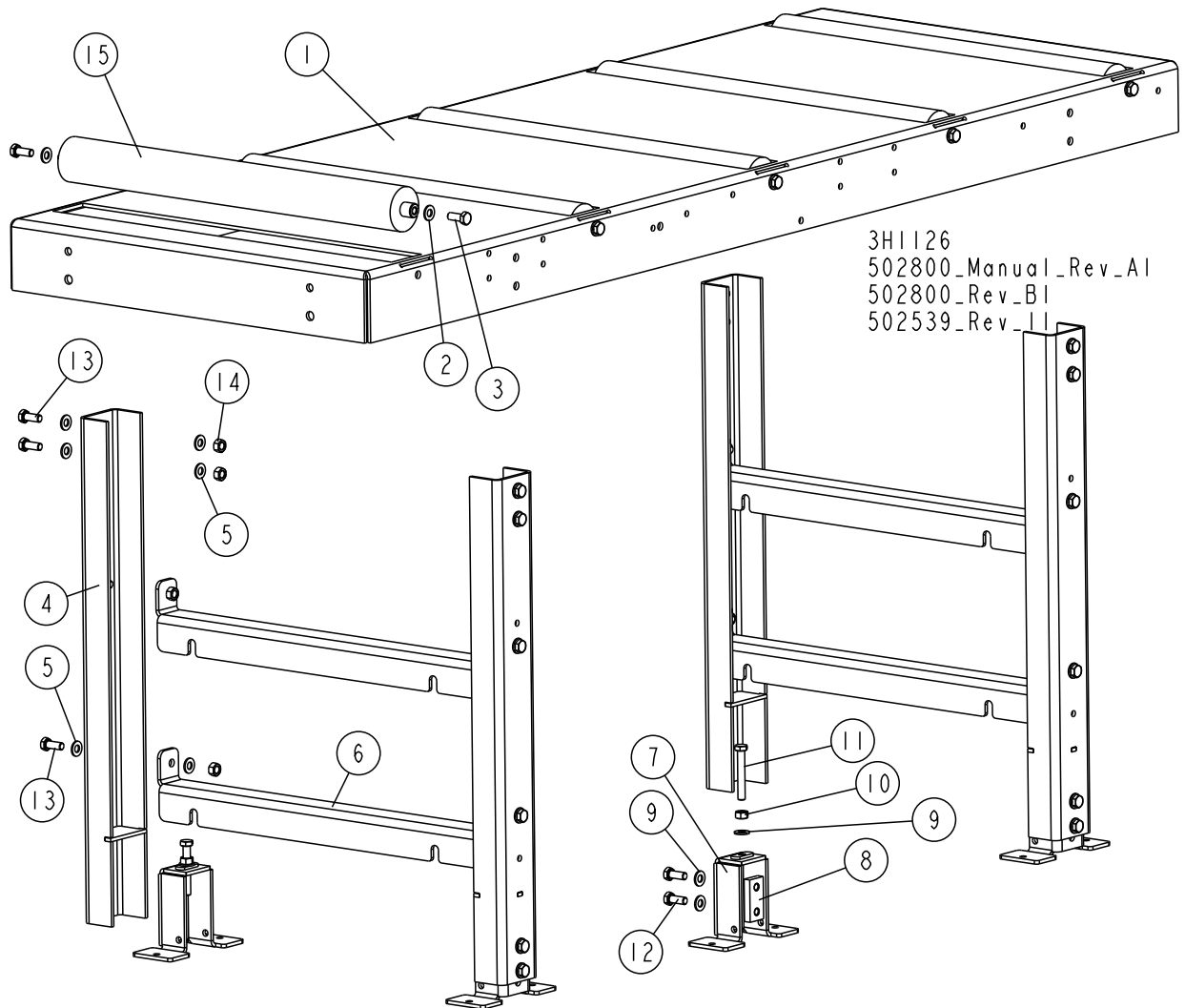

REF.	DESCRIPTION (◆ Indicates Parts Available in Assemblies Only)	PART #	QTY
	LONG TABLE, "M" FRAME	502539	1
1	TABLE WLDMT, BOARD RETURN	512488-1	1
2	Washer, 10.5 Flat	F81055-1	10
3	BOLT, M10 X 25-8.8 HEX HEAD FULL THREAD ZINC	F81003-11	10
	LEG, TABLE COMPLETE	501974	2
4	LEG, TABLE	501976	2
5	WASHER, 10.5 FLAT	F81055-1	15
6	CROSS-BAR, TABLE	500074-1	2
	COMPLETE, ADJUSTABLE LEG FOOT	101014	2
7	FOOT, LEG ADJUSTABLE	101022-1	1
8	PLATE, M10 CLAMPING ZINC-PLATED	101242-1	1
9	WASHER, 10.5 FLAT	F81055-1	3
10	NUT, M10-8-B-HEX ZINC	F81033-3	1
11	BOLT, M10x70-8.8-HEX HEAD FULL THREAD ZINC	F81003-20	1
12	BOLT, M10x25-8.8-HEX HEAD FULL THREAD ZINC	F81003-11	2

REF.	DESCRIPTION (◆ Indicates Parts Available In Assemblies Only)	PART #	QTY	
13	BOLT, M10x25-8.8-HEX HEAD FULL THREAD ZINC	F81003-11	8	
14	NUT, M10-8-B-HEX ZINC	F81033-3	8	
15	ROLLER 63.5/20X590	501090-1	5	

8.19 Pivot Bed Rail Assembly

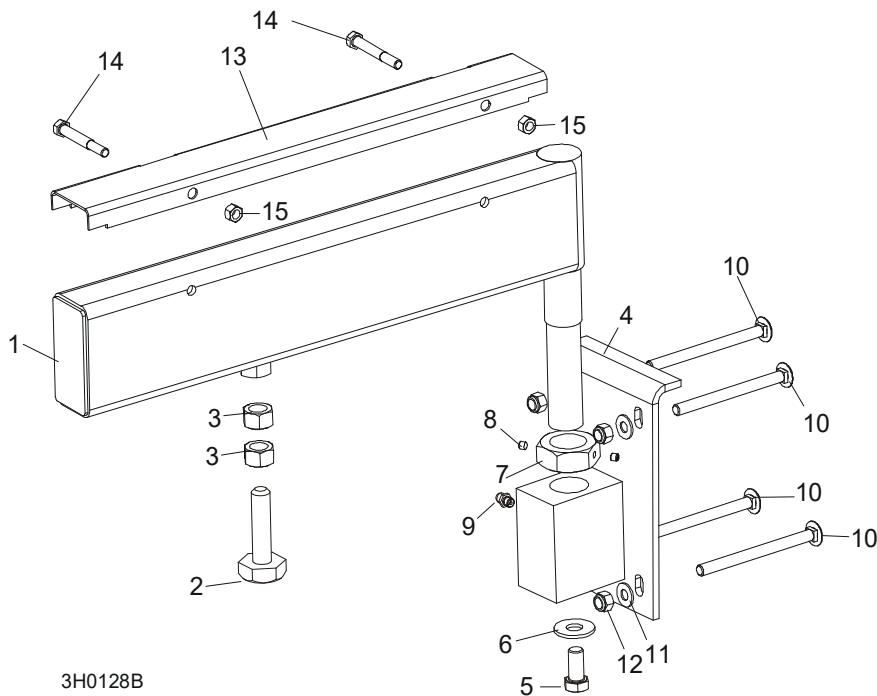

3H0128B

REF.	DESCRIPTION (◆ Indicates Parts Available In Assemblies Only)	PART #	QTY
	PIVOT BED RAIL ASSEMBLY (LT40SAH)	087829	2
	PIVOT BED RAIL ASSEMBLY (LT40)	087855	2
1	Pivot Bed Rail Weldment (LT40SAH)	087852	1
	Pivot Bed Rail Weldment (LT40)	087848	1
	Bolt Assembly, Bed Rail Adjustment		1
2	Bolt, Bed Rail Adjustment	086809	1
3	Nut, 5/8-11 Hex	F81036-1	2
4	Bracket, Pivot Rail Mounting	087841-1	1
5	Bolt, M12X25-8.8 Hex Head Full Thread Zinc	F81004-31	1
6	Washer, 15 Flat	F05011-52	1
7	Nut, M32x2-04-B Zinc	087975	1
8	Screw, 1/4-28 x 1/4" Brass Tip Set	F05005-42	2
9	Fitting, 3/16" Grease	086280	1
10	BOLT, M10X120 8.8 CARRIAGE ZINC	F81003-33	4
11	WASHER, 10.5 FLAT ZINC	F81055-1	4
12	NUT, M10-8-B HEX NYLON ZINC LOCK	F81033-1	4
	COVER KIT, PIVOT RAIL STAINLESS STEEL (LT40SAH)	015926	2
	COVER KIT, PIVOT RAIL STAINLESS STEEL (LT40)	N/A	2
13	Cover, Stainless Steel Pivot Bed Rail (LT40SAH)	012994	1
	Cover, Stainless Steel Pivot Bed Rail (LT40)	099123	1
14	Bolt, M8x65-5.8 Zinc Hex Head	F81002-3	4
15	Nut, M8-8-B-Zinc Hex Nylon Lock	F81032-2	4
	WRENCH, BED RAIL ADJUSTMENT (See Section 8.5)	015970	1

8.20 Bed Rail Assembly, Optional End

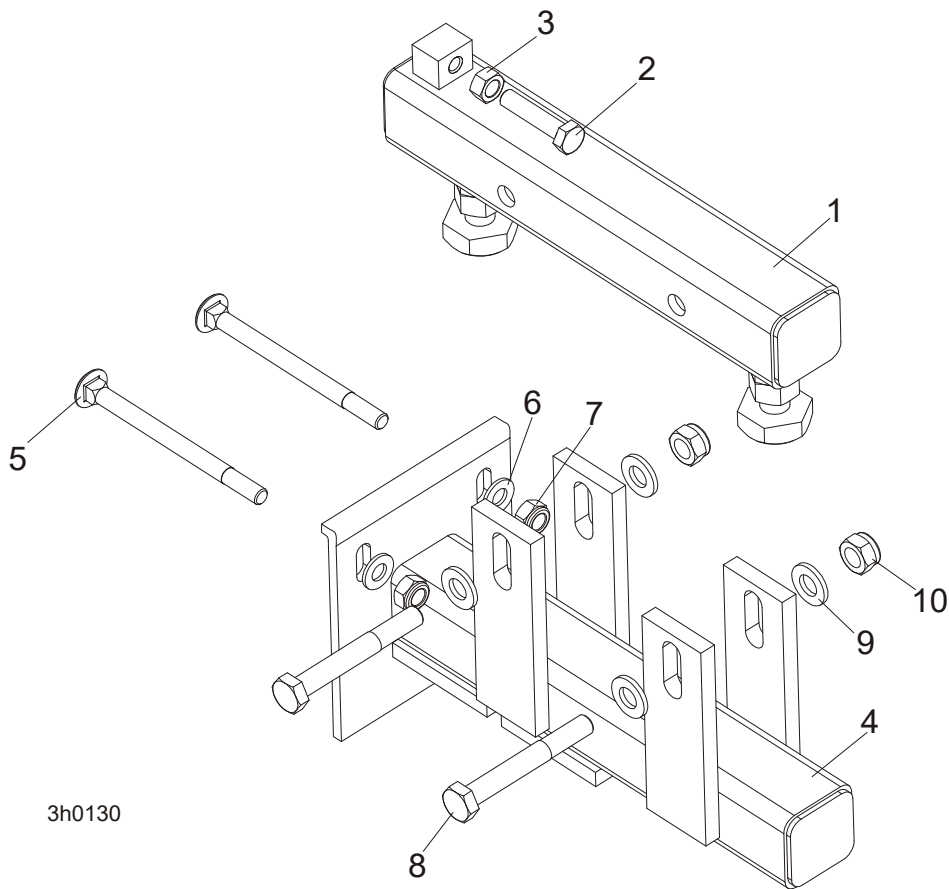

REF.	DESCRIPTION (◆ Indicates Parts Available In Assemblies Only)	PART #	QTY
	BED RAIL ASSY, OPTIONAL END	094102	1
1	Bed Rail Assy - Zinc	094103-1	1
2	Bolt, M8x45-8.8 Hex Head Full Thread Zinc	F81002-14	1
3	Nut, M8-8-B Hex Zinc	F81032-1	1
4	Bed Rail Weldment, End	094104-1	1
5	Bolt, M10X120 8.8 Carriage Zinc	F81003-33	2
6	Washer, 10.5 Zinc Flat	F81055-1	2
7	Nut, M10-8-B Nylon Hex Zinc Lock	F81033-1	2
8	Bolt, M12x90-8.8 Hex Head Zinc	F81004-2	2
9	Washer, 13 Zinc Flat	F81056-1	4
10	Nut, M12-8 Hex Nylon Zinc Lock	F81034-2	2

8.21 Log Side Support Assembly

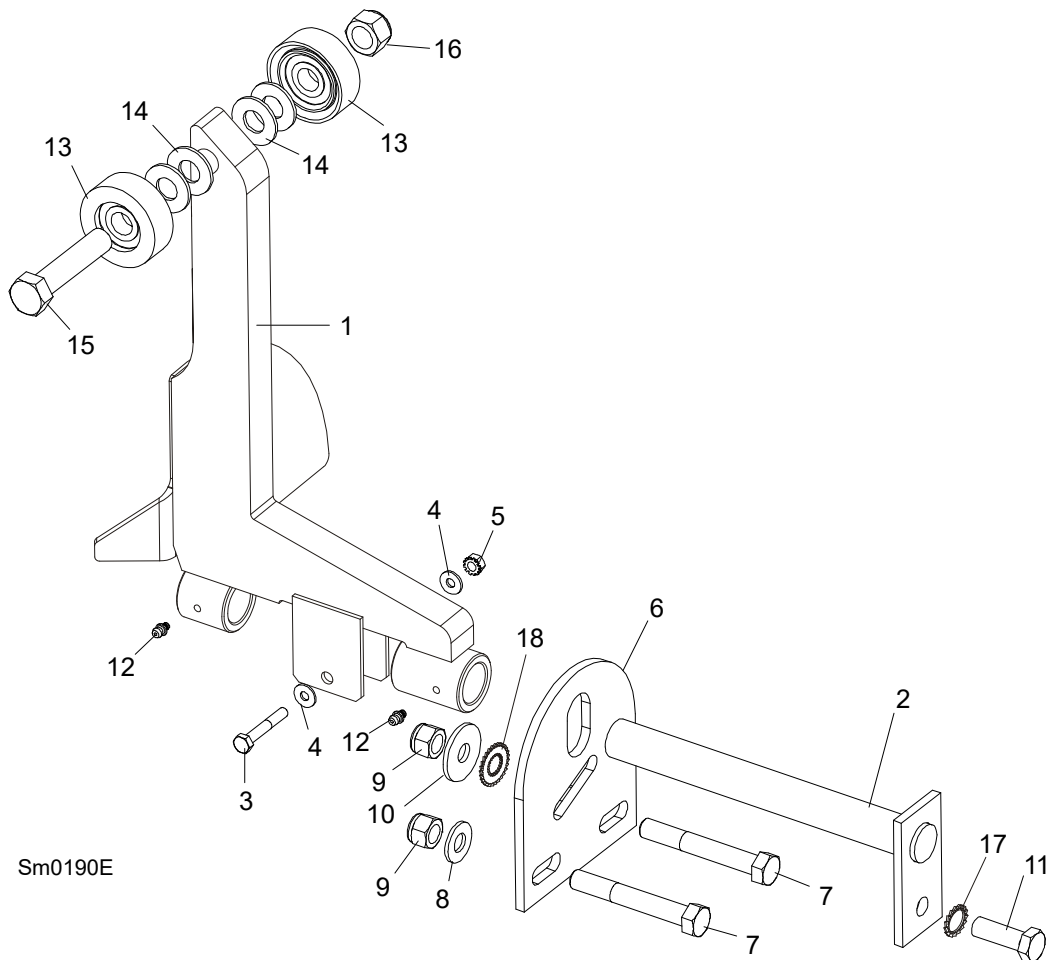

REF.	DESCRIPTION (◆ Indicates Parts Available In Assemblies Only)	PART #	QTY
1	SUPPORT, LOG SIDE W/GUARD	099785-1	1
2	PIN, LOG SIDE SUPPORT PIVOT	091549-1	1
3	BOLT, M8X45 - 8.8 HEX HEAD FULL THREAD ZINC	F81002-14	1
4	WASHER, 8.4 FLAT	F81054-1	2
5	NUT, M8-8-B SELF-LOCKING	F81032-2	1
6	PLATE, LOG SIDE SUPPORT END	091591-1	1
7	BOLT, M12 X 75-8.8 HEX HEAD	F81004-21	2
8	WASHER, 13 FLAT	F81056-1	2
9	NUT, M12-8 HEX NYLON LOCK	F81034-2	3
10	WASHER, 15 FLAT SPECIAL ZINC-PLATED	F81057-3	1
11	BOLT, M12 X 35-8.8 HEX HEAD	F81004-24	1
12	FITTING, 3/16" GREASE	P04107	2
13	ROLLER ASSEMBLY, SIDE SUPPORT	015014-1	2
14	WASHER, 17 FLAT	F81058-1	2
15	BOLT, M16X65-8.8-B HEX HEAD FULL THREAD ZINC	F81006-1	1
16	NUT, M16-8 NYLON LOCK	F81036-2	1
17	WASHER, BN781 M12/13 EXTERNALLY SERRATED	F81056-16	1
18	WASHER, SPECIAL BOSART/2S M12/12,3/30,3		1
	INSTRUCTION SHEET, SIDE SUPPORT ROLLER	015109-526	1

8.22 Tie Down Chain Assembly

SM0129

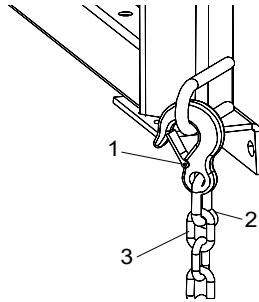

REF.	DESCRIPTION (◆ Indicates Parts Available In Assemblies Only)	PART #	QTY	
	CHAIN ASSEMBLY, TIE DOWN	A04376-1	1	
1	Hook, 5/8" Safety Chain	P12075	1	◆
2	Link, 10 cCHAIN	100767	1	◆
3	Chain, N-10 x 35, 6 Links	100951	1	◆

8.23 Saw Head Transport Bracket

532167_001
532167_MANUAL

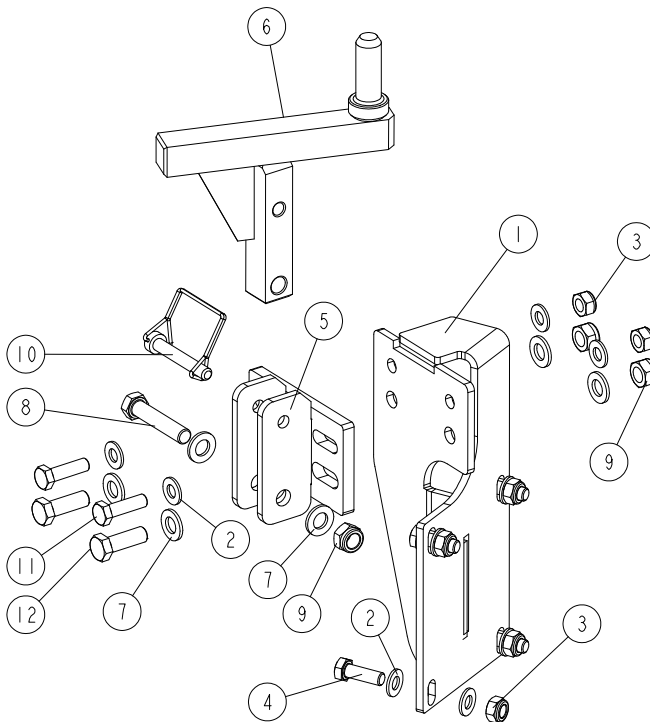

REF.	DESCRIPTION (◆ Indicates Parts Available In Assemblies Only)	PART #	QTY	
-	BRACKET, LT40M/S SAW HEAD TRANSPORT - COMPLETE	532167	1	
1	BRACKET, LT70MD42SDH7-2.6	502711-1	1	
2	WASHER, 10.5 FLAT ZINC	F81055-1	12	
3	NUT, M10-8-B HEX NYLON ZINC LOCK	F81033-1	6	
4	BOLT, M10X30-8.8 HEX HEAD FULL THREAD ZINC	F81003-2	4	
5	BRACKET, LT40	092765-1	1	



Bed Frame Assembly

Saw Head Transport Bracket

REF.	DESCRIPTION (◆ Indicates Parts Available In Assemblies Only)	PART #	QTY	
6	PIN WELDMENT, LT40 SAW HEAD REST	532166-1	1	
7	WASHER, 13 FLAT ZINC	F81056-1	6	
8	BOLT, M12X60-8.8 HEX HEAD ZINC	F81004-5	1	
9	NUT, M12 8 HEX NYLON ZINC LOCK	F81034-2	3	
10	PIN, 3/8X2 1/4 SQ WIRE LOCK	014151	1	
11	BOLT, M10X35 8.8 HEX HEAD FULL THREAD ZINC	F81003-17	2	
12	BOLT, M12X35 8.8 HEX HEAD FULL THREAD ZINC	F81004-24	2	

8.24 Saw Head Transport Bracket (for beds w/angled bed rails)

525089_001
525089_MANUAL

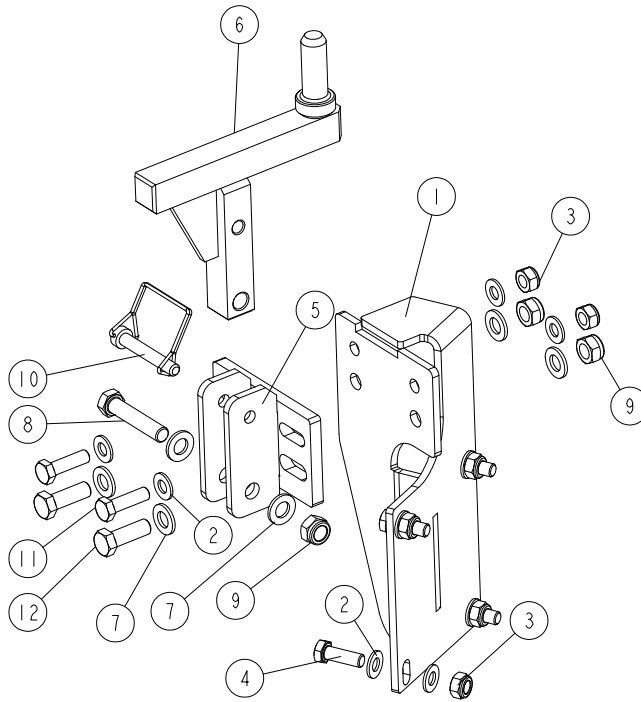

REF.	DESCRIPTION (◆ Indicates Parts Available In Assemblies Only)	PART #	QTY
-	BRACKET, LT40M SAW HEAD TRANSPORT (FOR BEDS W/ANGLED BED RAILS)	525089	1
1	BRACKET, LT70MD42SDH7-2.6	502711-1	1
2	WASHER, 10.5 FLAT ZINC	F81055-1	12
3	NUT, M10-8-B HEX NYLON ZINC LOCK	F81033-1	6
4	BOLT, M10X30-8.8 HEX HEAD FULL THREAD ZINC	F81003-2	4
5	BRACKET, LT40	092765-1	1
6	PIN WELDMENT, LT50 SAW HEAD REST	090421-1	1
7	WASHER, 13 FLAT ZINC	F81056-1	6
8	BOLT, M12X60-8.8 HEX HEAD ZINC	F81004-5	1
9	NUT, M12 8 HEX NYLON ZINC LOCK	F81034-2	3
10	PIN, 3/8X2 1/4 SQ WIRE LOCK	014151	1
11	BOLT, M10X35 8.8 HEX HEAD FULL THREAD ZINC	F81003-17	2
12	BOLT, M12X35 8.8 HEX HEAD FULL THREAD ZINC	F81004-24	2

8 Bed Frame Assembly

Saw Head Rest Bracket (LT20/40 Sawmills)

8.25 Saw Head Rest Bracket (LT20/40 Sawmills)

546306_001
546306_MANUAL

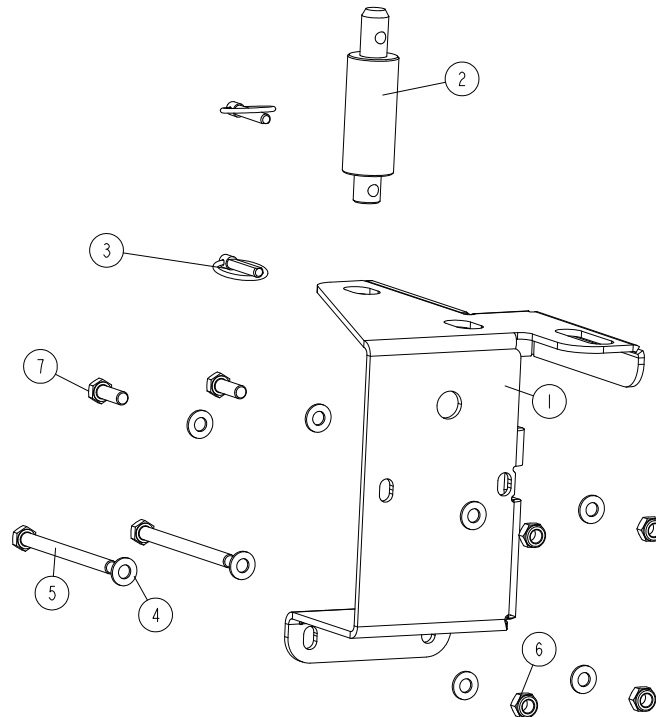

REF.	DESCRIPTION (◆ Indicates Parts Available In Assemblies Only)	PART #	QTY
-	BRACKET, SAW HEAD REST - FOR LT MACHINES	546306	1
1	PLATE, SAW HEAD REST BRACKET	546307-1	1
2	PIN, LT20 SAW HEAD REST	097935-1	1
3	PIN, 8 BN914 (BOSSARD 1364650) LOCK	F81046-2	2
4	WASHER, 10.5 FLAT ZINC	F81055-1	8
5	BOLT, M10X125 8.8 HEX HEAD ZINC	F81003-18	2
6	NUT, M10-8-B HEX NYLON ZINC LOCK	F81033-1	4
7	BOLT, M10X30-8.8 HEX HEAD FULL THREAD ZINC	F81003-2	2

8.26 Saw Head Bracket LT40 WIDE

555180_001
555180_MANUAL

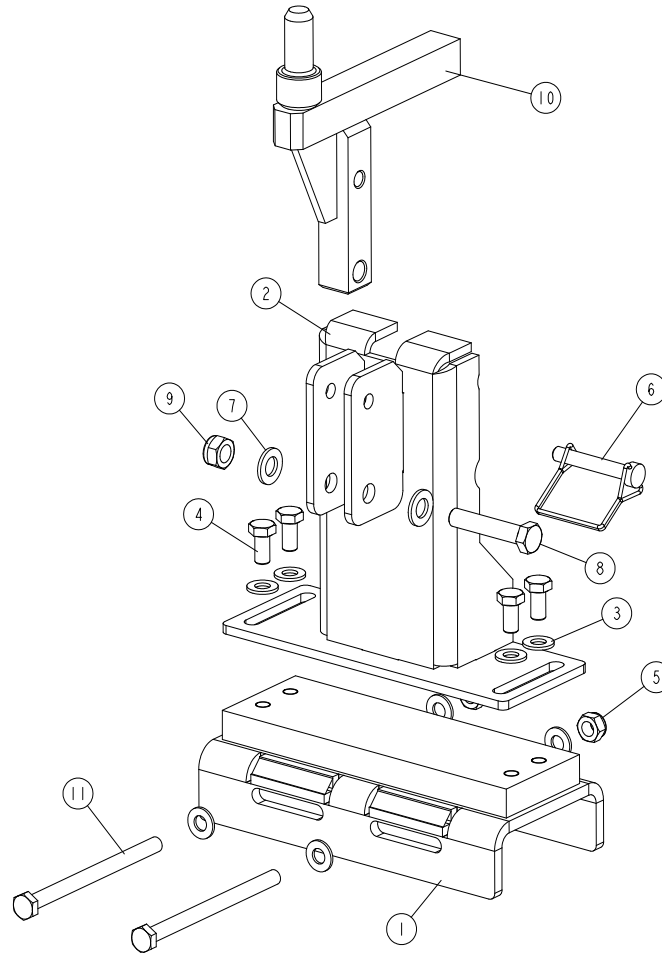

REF.	DESCRIPTION (◆ Indicates Parts Available In Assemblies Only)	PART #	QTY
-	SAW HEAD BRACKET, LT40 WIDE- M-FRAME	555180	1
1	BASE, SAW HEAD BRACKET LT20/40/70	545600-1	1
2	BASE, SAW HEAD LT40 WIDE WLDMT/PTD	545621-1	1
3	WASHER, 10,5 FLAT ZINC	F81055-1	8
4	BOLT, ISO 4017-M10X20-8.8-A2E HEX HEAD	F81003-53	4
5	NUT, M10 HEX NYLON ZINC LOCK	F81033-1	2
6	PIN, 3/8X2 1/4 SNAP	014151	1
7	WASHER, 13-FLAT ZINC	F81056-1	2
8	BOLT, M12X60-8.8-HEX HEAD ZINC	F81004-5	1
9	NUT, M12- 8- DIN 982 HEX NYLON ZINC LOCK	F81034-2	1
10	PIN,LT40 WIDE SAW HEAD REST	545664-1	1
11	BOLT, M10X140-8.8 HEX HEAD ZINC	F81003-5	2

8.27 Inspection Platform

545646_001
 545646_MANUAL

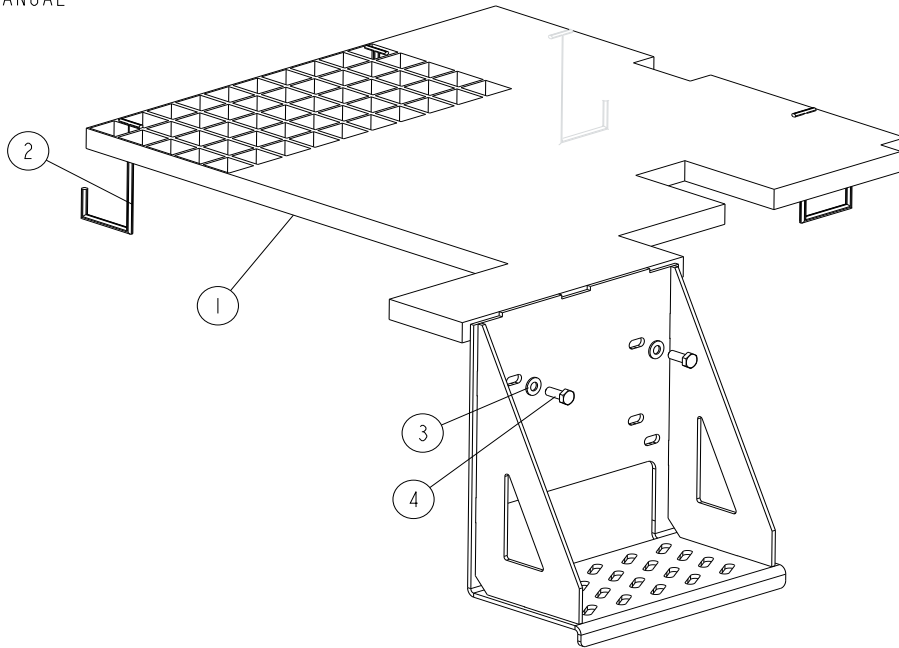

REF.	DESCRIPTION (◆ Indicates Parts Available In Assemblies Only)	PART #	QTY
-	PLATFORM, "M" FRAME INSPECTION - COMPLETE	545646	1
1	PLATFORM, "M" FRAME INSPECTION	506046-1	1
2	BRACKET, HOOK	085682	4
3	WASHER, 8.4 FLAT ZINC	F81054-1	2
4	BOLT, M8X20 8.8 HEX HEAD FULL THREAD ZINC	F81002-4	2

8.28 Inspection Platform (New M-type Frame, Mobile Sawmills)

545567_001
545567_MANUAL

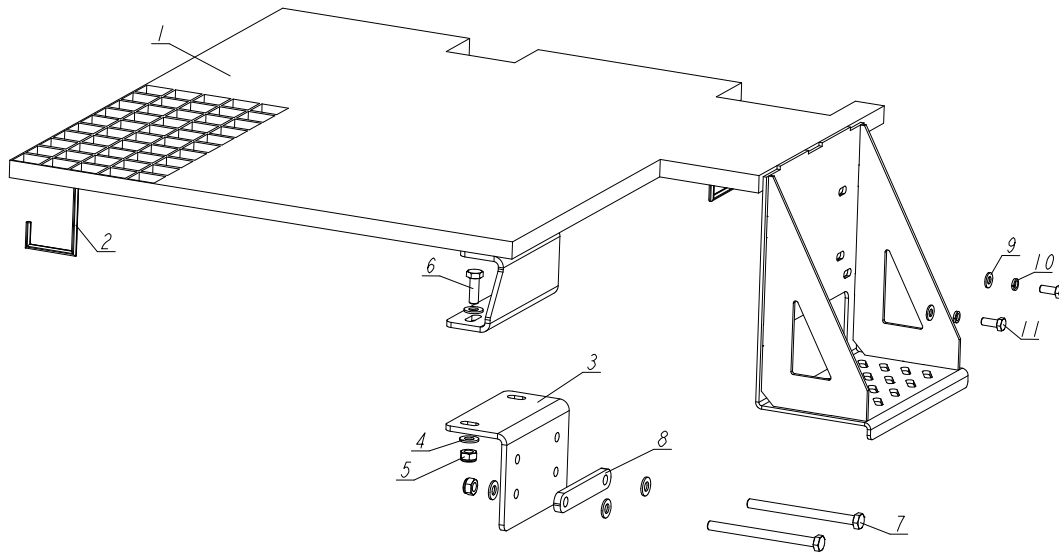

REF	DESCRIPTION (◆ indicates parts available in assemblies only)	PART #	QTY
-	PLATFORM, NEW M-TYPE FRAME INSPECTION - COMPLETE	545567	1
1	PLATFORM, INSPECTION - PAINTED	545566-1	1
2	BRACKET, HOOK	085682	4
3	PLATE, MOUNTING ANGLE	555223-1	1
4	WASHER, 10.5 FLAT ZINC	F81055-1	8
5	NUT, M10-8-B HEX NYLON ZINC LOCK	F81033-1	4
6	BOLT DIN 933-M10X30 8.8-A2E	F81003-111	2
7	BOLT, M10X130-8.8 FE/ZN5 PN-M/82105	F81003-170	2
8	WASHER	555221-1	1
9	WASHER, 8.4 FLAT ZINC	F81054-1	2
10	WASHER, 8.2 SPLIT LOCK ZINC	F81054-4	2
11	BOLT, M8X20-8.8-B HEX HEAD FULL THREAD ZINC	F81002-4	2

8.29 Inspection Platform for Wide "M" Frame

545671_001
 545671_MANUAL

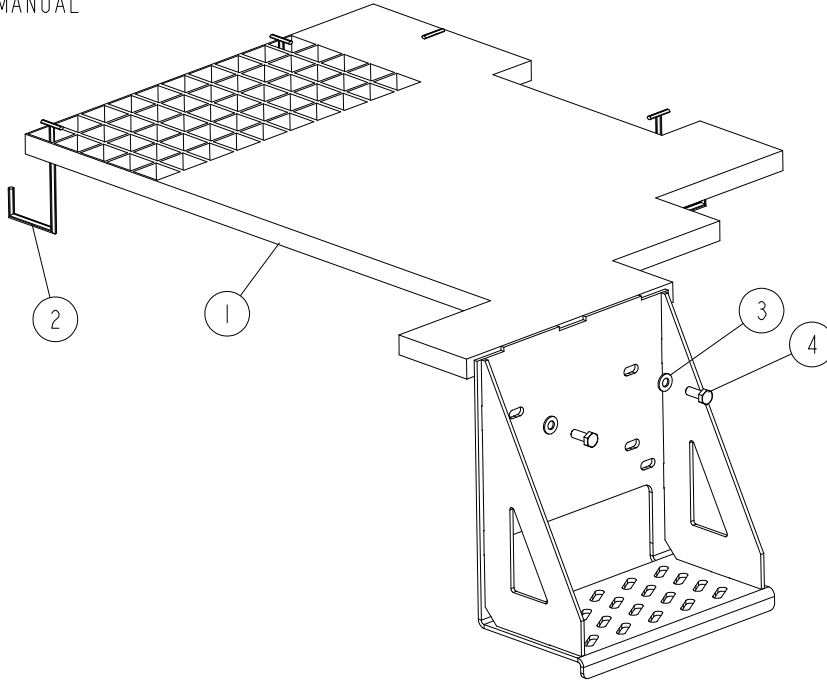

REF.	DESCRIPTION (◆ Indicates Parts Available In Assemblies Only)	PART #	QTY
-	PLATFORM, WIDE "M" FRAME INSPECTION	545671	1
1	PLATFORM, WIDE "M" FRAME INSPECTION	545669-1	1
2	BRACKET, HOOK	085682	4
3	WASHER, 8.4 FLAT ZINC	F81054-1	2
4	BOLT, M8X20 8.8 HEX HEAD FULL THREAD ZINC	F81002-4	2

8.30 Inspection Platform (M-type Frame Sawmills)

555244_001
 555244_MANUAL

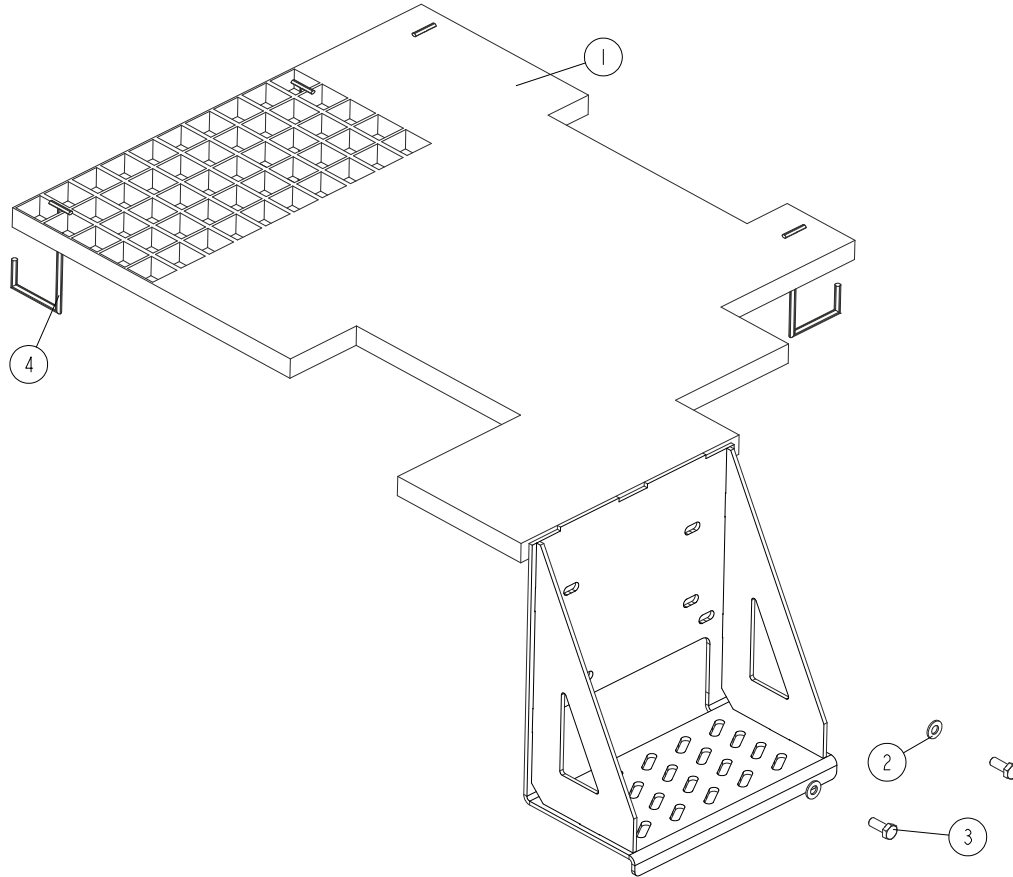

REF	DESCRIPTION (◆ indicates parts available in assemblies only)	PART #	QTY
-	PLATFORM, M-TYPE FRAME INSPECTION ¹	555244	1
1	PLATFORM, M-TYPE FRAME INSPECTION	555243-1	1
2	WASHER, 8.4 FLAT ZINC	F81054-1	2
3	BOLT, M8X20-8.8-B HEX HEAD FULL THREAD Z	F81002-4	2
4	BRACKET, HOOK	085682	4

¹ SAWMILLS EQUIPPED WITH POWER ROLLER

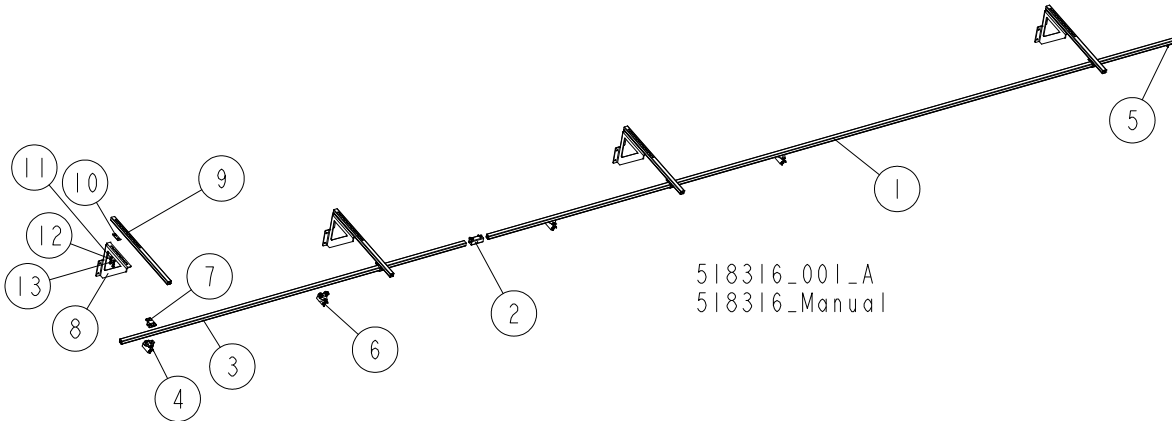
8.31 Remote Equipment for Installation on a Wall (Cutting Length of 6.5 m)

REF.	DESCRIPTION (◆ Indicates Parts Available In Assemblies Only)	PART #	QTY
	REMOTE EQUIPMENT (CUTTING LENGTH OF 6.5 M)	518316	1
	RAIL, COMPLETE GUIDE (CUTTING LENGTH OF 6.5M)	518315	1
1	RAIL, 6 M C-PROFILE	518332	1
2	COUPLER, TRACK	518705	1
3	RAIL, 3 M C-PROFILE	518313	1
4	CLAMP, FLAT CABLE - END	518701	1
5	STOP, END	518700	1
6	TROLLEY, CABLE MOVING	518333	3
7	BRACKET, BOLT-ON	518702	4
	RAIL BRACKET KIT FOR WALL MOUNTING	518724	4
8	BRACKET, GUIDE RAIL (FOR WALL MOUNTING)	518728-1	1
9	ARM, RAIL BRACKET	518709	1
10	PLATE, ARM CLAMPING	518885-1	1
11	WASHER, 8.4 FLAT ZINC	F81054-1	2
12	WASHER, 8.2 SPLIT LOCK ZINC	F81054-4	2
13	BOLT, M8x16-8.8-B HEX HEAD FULL THREAD ZINC	F81002-20	2

8.32 Remote Equipment for Installation on a Wall (Cutting Length of 6.5-10 m)

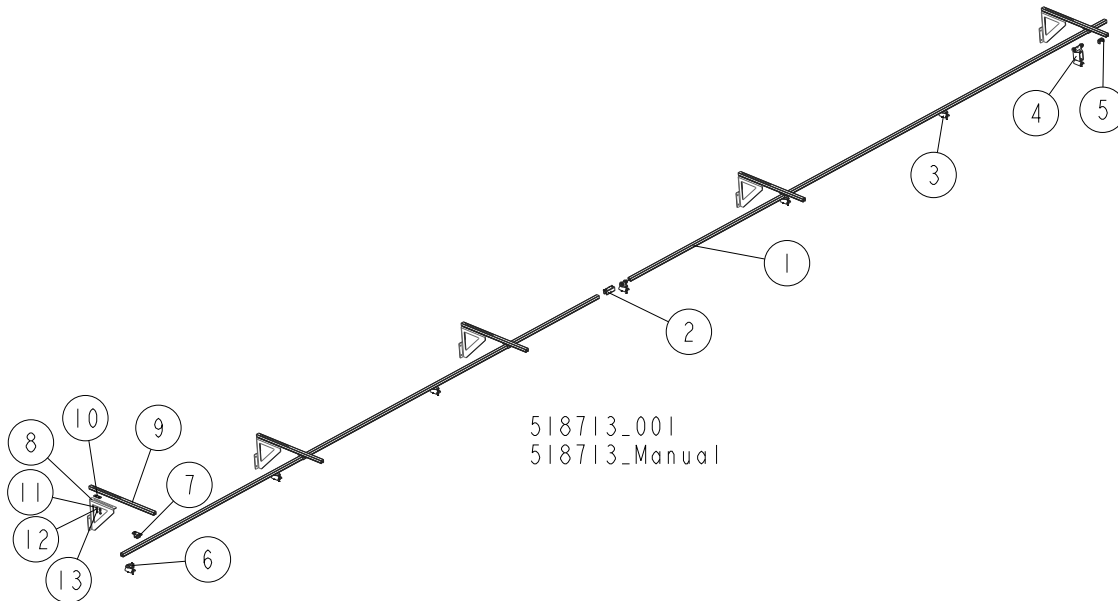

REF.	DESCRIPTION (◆ Indicates Parts Available In Assemblies Only)	PART #	QTY
	REMOTE EQUIPMENT (CUTTING LENGTH OF 6.5-10 M)	518713	1
	RAIL, COMPLETE GUIDE (CUTTING LENGTH OF 6.5-10 M)	518704	1
1	RAIL, 6 M C-PROFILE	518332	2
2	COUPLER, TRACK	518705	1
3	TROLLEY, CABLE MOVING	518333	5
4	TROLLEY, TOWING	518334	1
5	STOP, END	518700	1
6	CLAMP, FLAT CABLE - END	518701	1
7	BRACKET, BOLT-ON	518702	5
8	RAIL BRACKET KIT FOR WALL MOUNTING	518724	5
9	BRACKET, GUIDE RAIL (FOR WALL MOUNTING)	518728-1	1
10	ARM, RAIL BRACKET	518709	1
11	PLATE, ARM CLAMPING	518885-1	1
12	WASHER, 8.4 FLAT ZINC	F81054-1	2
13	WASHER, 8.2 SPLIT LOCK ZINC	F81054-4	2

8.33 Guide Rail Support Post

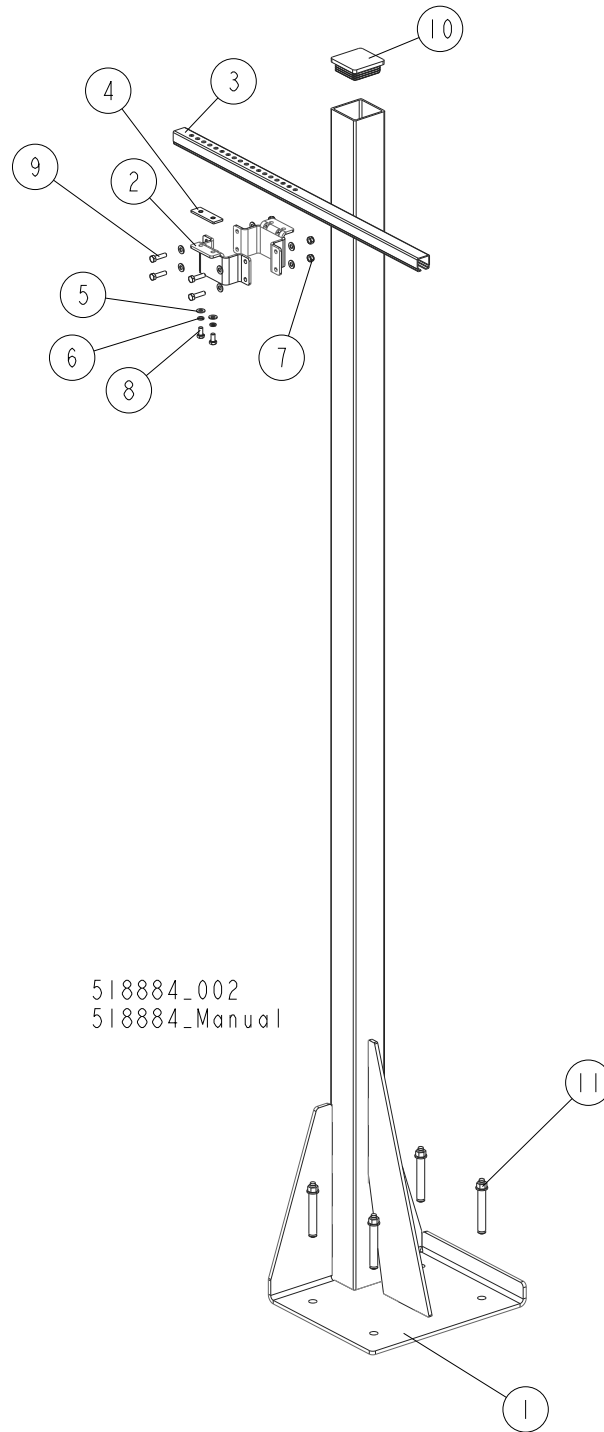

518884_002
 518884_Manual

REF.	DESCRIPTION (◆ Indicates Parts Available In Assemblies Only)	PART #	QTY
	POST, GUIDE RAIL SUPPORT - COMPLETE	518736	1
1	POST, GUIDE RAIL SUPPORT	518707-1	1
2	BRACKET, 80X80 TUBE WRAP	518725-1	2
3	ARM, RAIL BRACKET	518709	1
4	PLATE, ARM CLAMPING	518885-1	1

REF.	DESCRIPTION (◆ Indicates Parts Available In Assemblies Only)	PART #	QTY
5	WASHER, 8.4 FLAT ZINC	F81054-1	10
6	WASHER, 8.2 SPLIT LOCK ZINC	F81054-4	2
7	NUT, M8 8 HEX NYLON ZINC LOCK	F81032-2	4
8	BOLT, M8X16-8.8-B HEX HEAD FULL THREAD ZINC	F81002-20	2
9	BOLT, M8X30-5.8-B HEX HEAD FULL THREAD ZINC	F81002-2	4
10	CAP, 80X80 2-4 #111227 TUBE END	089644	1
11	PIN, LT 16X120	501877	4

8.34 Guide Rail Support Post

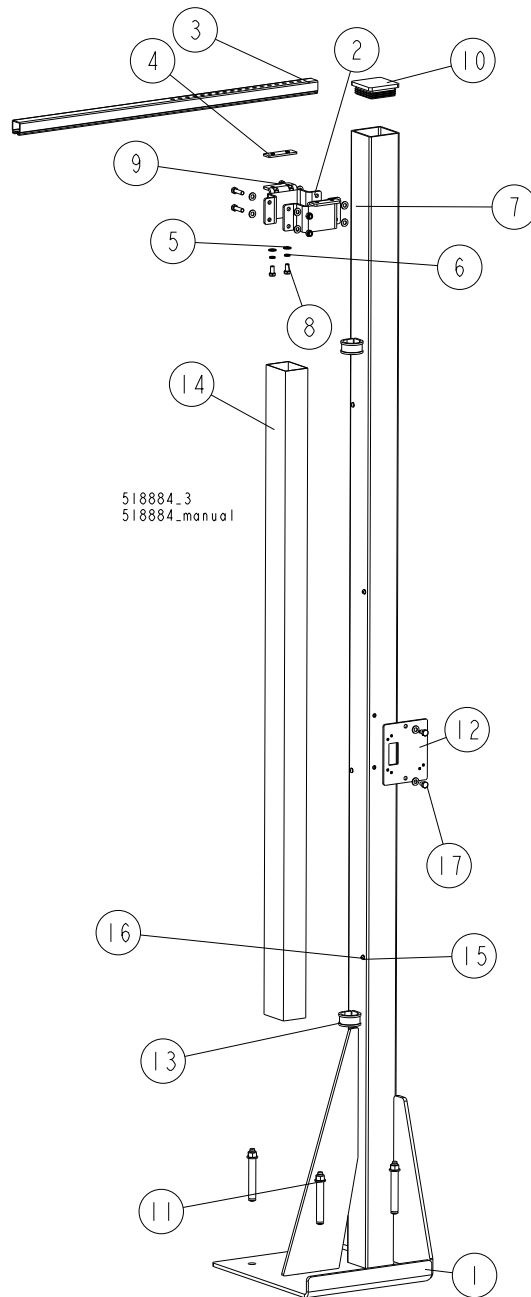

REF.	DESCRIPTION (◆ Indicates Parts Available In Assemblies Only)	PART #	QTY
	POST, GUIDE RAIL SUPPORT - COMPLETE	520669	1
1	POST WELDMENT W/HOLES	520667-1	1
2	BRACKET, 80X80 TUBE WRAP	518725-1	2
3	ARM, RAIL BRACKET	518709	1
4	PLATE, ARM CLAMPING	518885-1	1
5	WASHER, 8.4 FLAT ZINC	F81054-1	14
6	WASHER, 8.2 SPLIT LOCK ZINC	F81054-4	2

REF.	DESCRIPTION (◆ Indicates Parts Available In Assemblies Only)	PART #	QTY
7	NUT, M8 8 HEX NYLON ZINC LOCK	F81032-2	4
8	BOLT, M8X16-8.8-B HEX HEAD FULL THREAD ZINC	F81002-20	4
9	BOLT, M8X30-5.8-B HEX HEAD FULL THREAD ZINC	F81002-2	4
10	CAP, 80X80 GR 2-4 #111227 TUBE END	089644	1
11	PIN, LT 16X120	501877	4
12	PLATE, SOCKET MOUNT	517664-1	1
13	CLAMP, RSGU 1.42/20 W1 METAL & RUBBER	F81087-3	2
14	DUCT, CABLE	520670	1
15	WASHER, 5.3 FLAT ZINC	F81052-1	4
16	SCREW, M5X10-8.8 CROSS RECESSED PAN HEAD ZINC	F81000-13	4
17	BOLT, M8X12-8.8 HEX HEAD FULL THREAD ZINC	F81002-6	2

8 Bed Frame Assembly

4-Post Remote Set

8.35 4-Post Remote Set

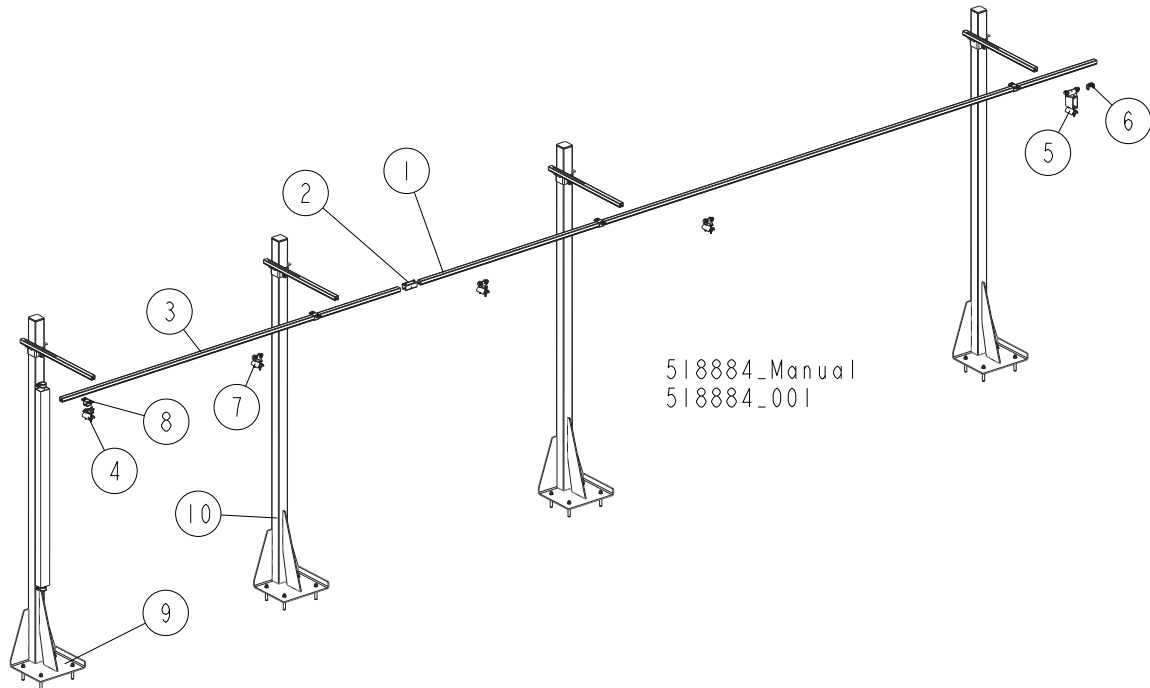

REF.	DESCRIPTION (◆ Indicates Parts Available In Assemblies Only)	PART #	QTY
	REMOTE SET, 4-POST	518884	1
	RAIL, COMPLETE GUIDE (CUTTING LENGTH OF 6.5M)	518315	1
1	RAIL, 6 M C-PROFILE	518332	1
2	COUPLER, TRACK	518705	1
3	RAIL, 3 M C-PROFILE	518313	1
4	CLAMP, FLAT CABLE - END	518701	1
5	TROLLEY, TOWING	518334	1
6	STOP, END	518700	1
7	TROLLEY, CABLE MOVING	518333	3
8	BRACKET, BOLT-ON	518702	4
9	POST, GUIDE RAIL SUPPORT - COMPLETE See Section 8.36	520669	1
10	POST, GUIDE RAIL SUPPORT - COMPLETE See Section 8.35	518736	3

8.36 5-Post Remote Set

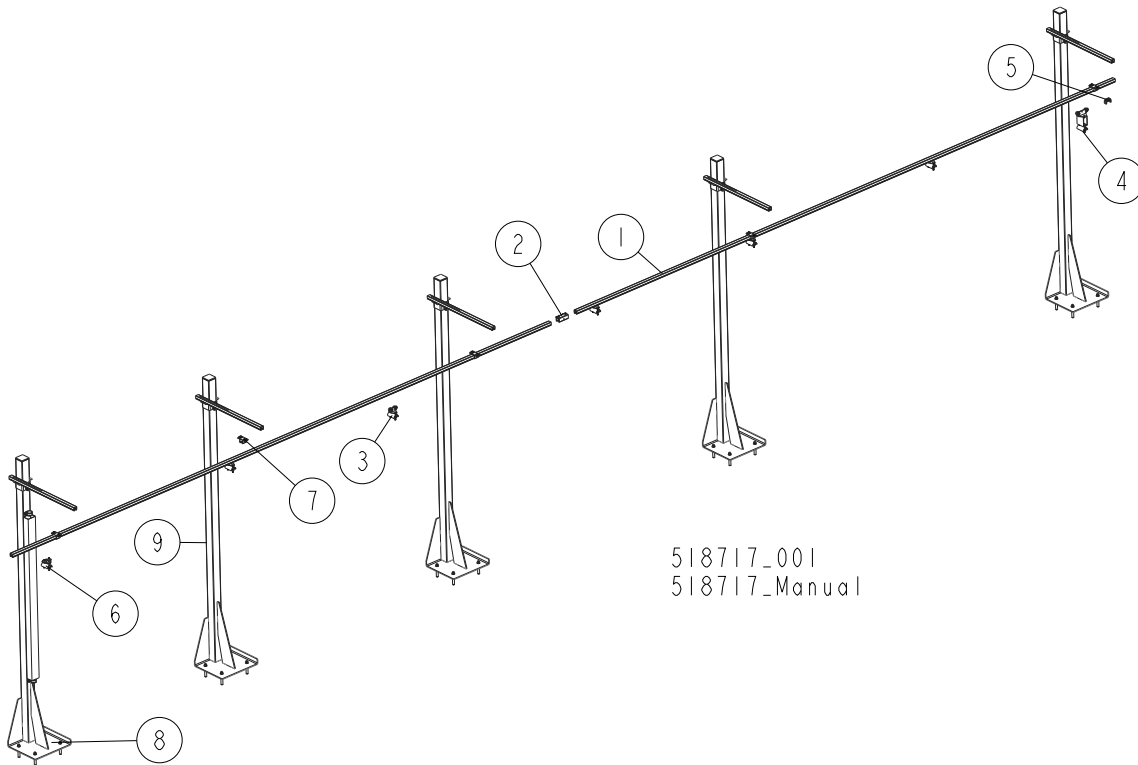

REF.	DESCRIPTION (◆ Indicates Parts Available In Assemblies Only)	PART #	QTY
	REMOTE SET, 5-POST	518717	1
	RAIL, COMPLETE GUIDE (CUTTING LENGTH OF 6.5-10 M)	518704	1
1	RAIL, 6 M C-PROFILE	518332	2
2	COUPLER, TRACK	518705	1
3	TROLLEY, CABLE MOVING	518333	5
4	TROLLEY, TOWING	518334	1
5	STOP, END	518700	1
6	CLAMP, FLAT CABLE - END	518701	1
7	BRACKET, BOLT-ON	518702	5
8	POST, GUIDE RAIL SUPPORT - COMPLETE See Section 8.36	520669	1
9	POST, GUIDE RAIL SUPPORT - COMPLETE See Section 8.35	518736	4

8 Bed Frame Assembly

Octagonal Profile Sawing Tool (Option)

8.37 Octagonal Profile Sawing Tool (Option)

520495_001
520495_MANUAL

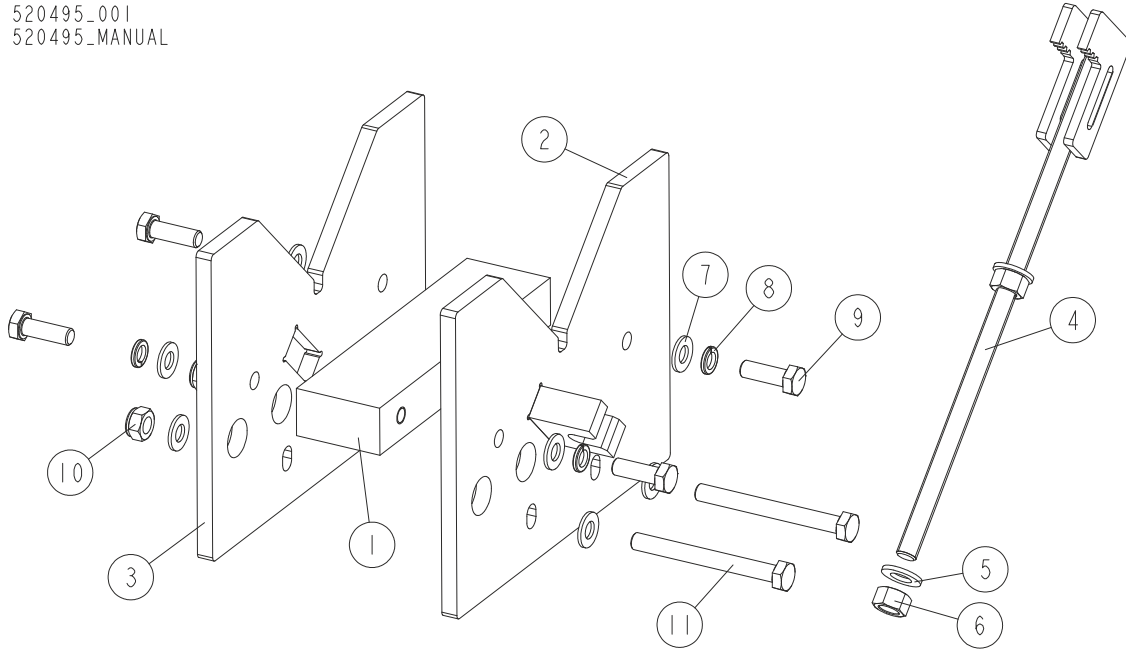

REF.	DESCRIPTION (◆ Indicates Parts Available In Assemblies Only)	PART #	QTY
-	TOOL, OCTAGONAL PROFILE SAWING	520495	1
1	BAR, INSIDE	520490-1	1
2	PLATE, FRONT	520492-1	1
3	PLATE, MAIN	520489-1	1
4	ARM, CLAMP	520496-1	1
5	WASHER, 13 FLAT ZINC	F81056-1	2
6	NUT, M12-8-B HEX ZINC	F81034-1	2
7	WASHER, 10.5 FLAT ZINC	F81055-1	8
8	WASHER, Z 10.2 SPLIT LOCK ZINC	F81055-2	4
9	BOLT, M10X30 5.8 HEX HEAD FULL THREAD ZINC	F81003-2	4
10	NUT, M10-8-B HEX NYLON ZINC LOCK	F81033-1	2
11	BOLT, M10X95-8.8-B HEX HEAD ZINC	F81003-71	2

8.38 Sawmill Transport Bracket Assembly (Option)

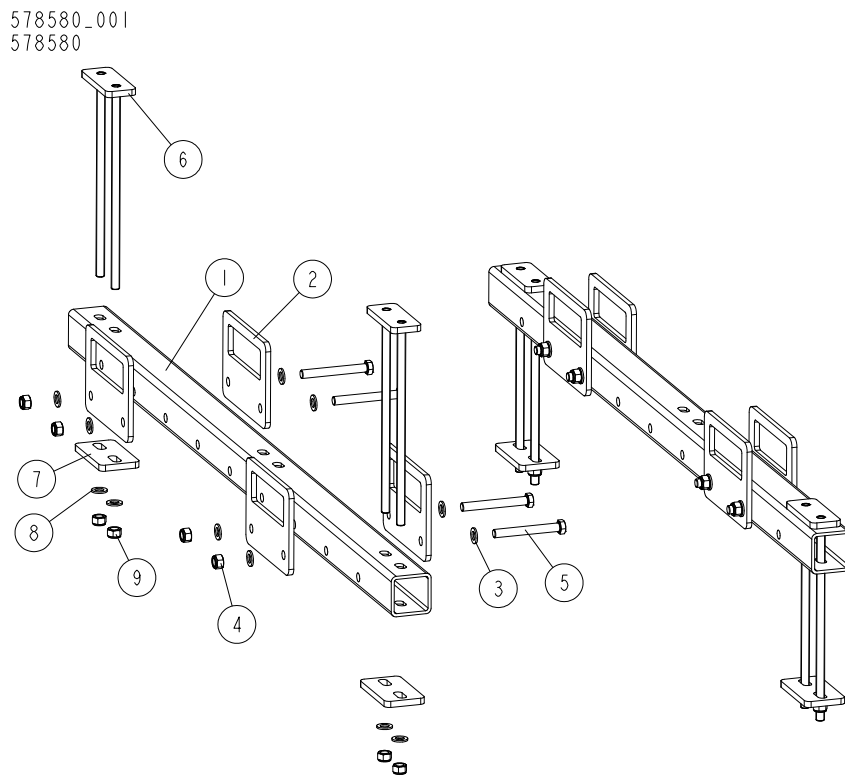

REF	DESCRIPTION (u indicates parts available in assemblies only)	PART #	QTY
-	TRANSPORT BRACKET ASSEMBLY, SAWMILLS	578580	1
-	BRACKET, TRANSPORT	578566	2
1	TUBE, TRANSPORT	578567-1	1
2	PLATE, TRANSPORT BRACKET	578569-1	4
3	WASHER, 17 FLAT ZINC	F81058-1	8
4	NUT, M16-8 HEX NYLON ZINC LOCK	F81036-2	4
5	BOLT, M16X130-8.8 HEX HEAD ZINC	F81006-35	4
-	CLAMP, FRAME	578572	2
6	PLATE	578577-1	1
7	PLATE, TRANSPORT BRACKET	578568-1	1
8	WASHER, 17 FLAT ZINC	F81058-1	2
9	NUT, M16-8 HEX NYLON ZINC LOCK	F81036-2	2

8.39 Bed Frame Decals

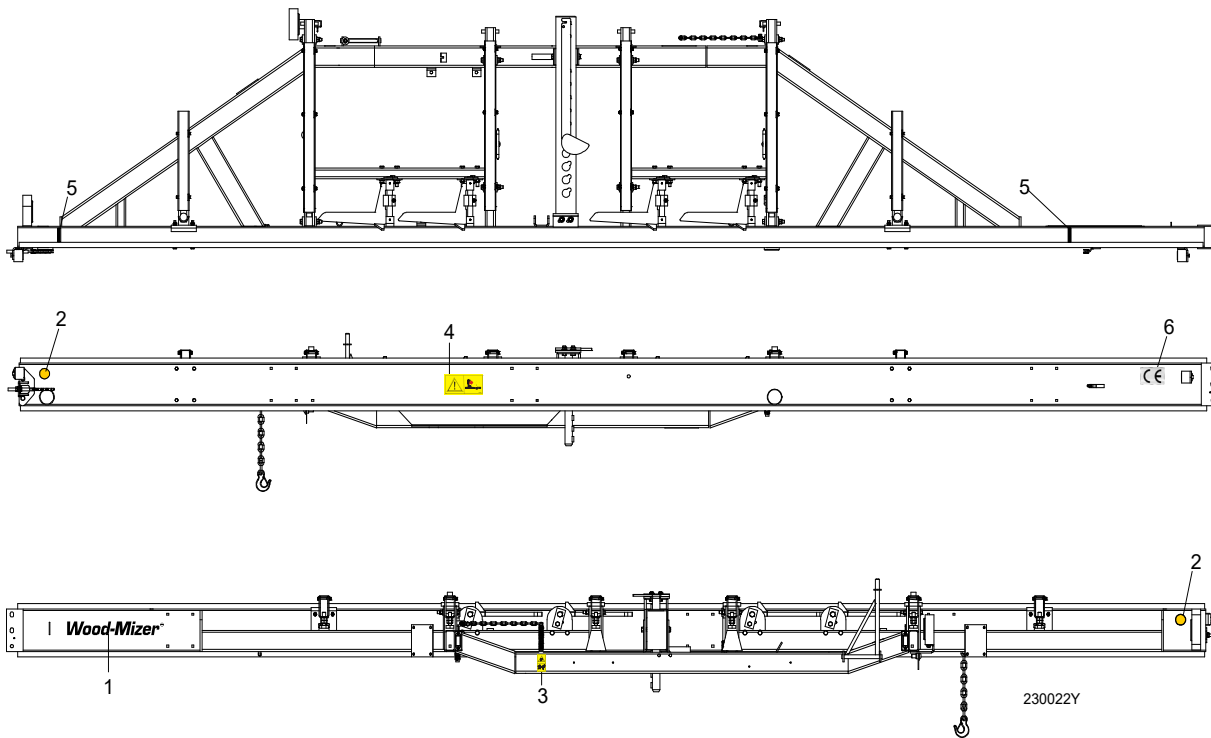

REF.	DESCRIPTION (◆ Indicates Parts Available In Assemblies Only)	PART #	QTY
1	DECAL, WOOD-MIZER SUPER LOGO	014751	1
2	DECAL, AMBER REFLECTIVE 2" ROUND	P07453	2
3	DECAL, KEEP AWAY DANGER, PICTOGRAM	099221	1
4	DECAL, SAWMILL TRAILER CAUTION, PICTOGRAM	099542	1
5	DECAL, LOG LIMIT STRIPE	S12051	2
6	DECAL, CE CERTIFIED SAWMILL, SMALL	P85070	1

8.40 Inspection Platform (M-type Frame Sawmills). 555380

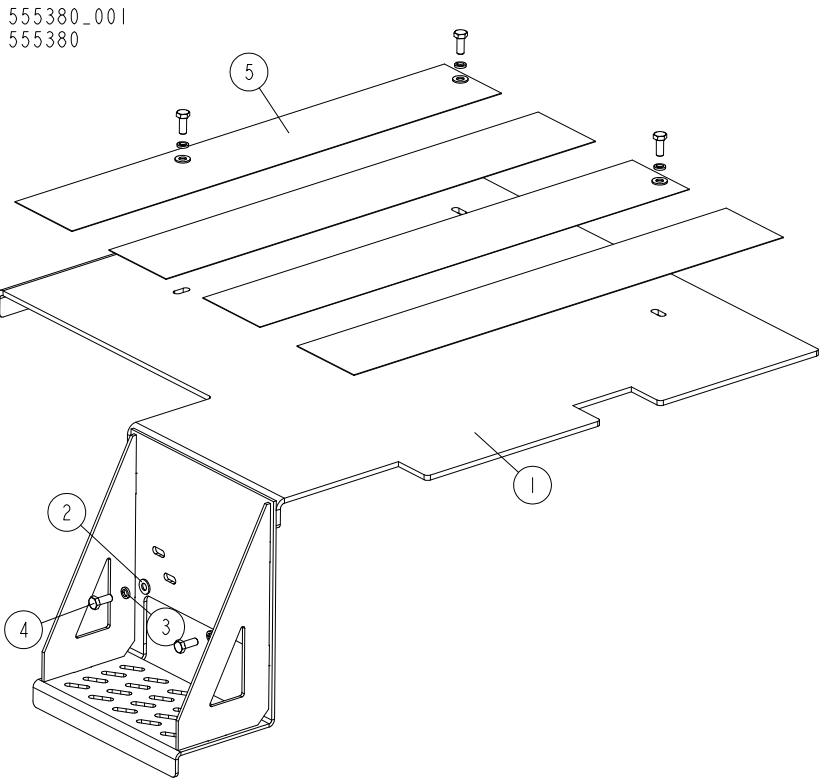

REF	DESCRIPTION (u indicates parts available in assemblies only)	PART #	QTY	
-	PLATFORM, "M" FRAME INSPECTION	555380	1	
1	PLATFORM, "M" FRAME INSPECTION	555375-1	1	
2	WASHER, 8.4 FLAT ZINC	F81054-1	5	
3	WASHER, 8.2 SPLIT LOCK ZINC	F81054-4	5	
4	BOLT, M8X20-8.8-B HEX HEAD FULL THREAD Z	F81002-4	5	
5	PAD, NON-SKID STEP	711495	4	

8.41 Stationary Legs for "M" Frame. 522944

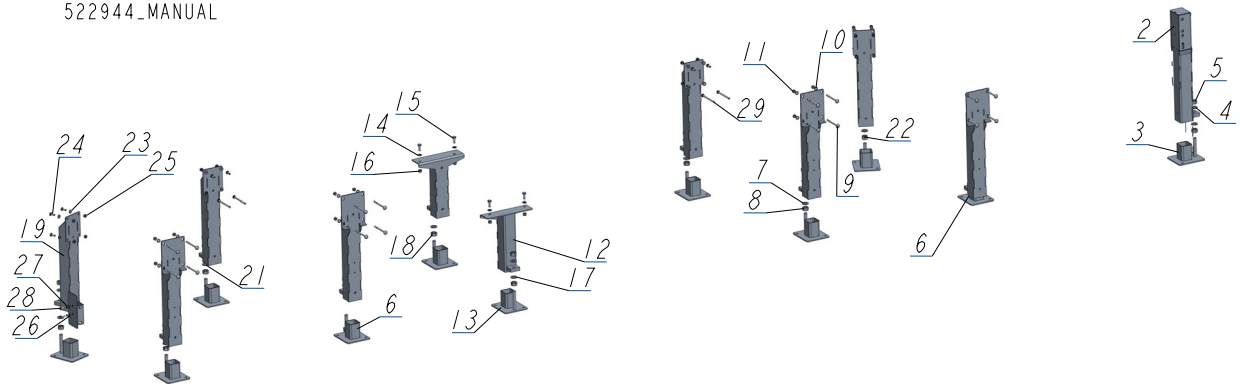
522944_001_B
522944_MANUAL

REF	DESCRIPTION (u indicates parts available in assemblies only)	PART #	QTY
-	LEG, M SUPER FRAME STATIONARY	522944	1
1	LEG, FRONT ADJUSTABLE STATIONARY	589525	1
2	LEG WELDMENT, FRONT ADJUSTABLE	589518-1	1
3	FOOT	586948-1	1
4	WASHER, 21 FLAT ZINC	F81059-2	2
5	NUT, M20-8- HEX ZINC	F81037-1	2
-	LEG, RIGHT ADJUSTABLE STATIONARY	501640	4
6	FOOT	586948-1	1
7	WASHER, 21 FLAT ZINC	F81059-2	2
8	NUT, M20-8- HEX ZINC	F81037-1	2
9	BOLT, M10X120 8.8 CARRIAGE ZINC	F81003-33	4
10	WASHER, 10.5 ZC DIN 126 ISO 7091	F81055-1	4
11	NUT, M10-8-B HEX NYLON ZINC LOCK	F81033-1	4
-	LEG, MIDDLE ADJUSTABLE STATIONARY	501637	2
12	LEG, MIDDLE	507720-1	1
13	FOOT	586948-1	1
14	WASHER, 13 FLAT ZINC	F81056-1	2
15	BOLT, M12X30 8.8 HEX HEAD FULL THREAD ZI	F81004-22	2
16	NUT, M12 8 HEX NYLON ZINC LOCK	F81034-2	2
17	WASHER, 21 FLAT ZINC	F81059-2	2
18	NUT, M20-8- HEX ZINC	F81037-1	2
-	LEG, LEFT STATIONARY ADJUSTABLE	501639	4
19	TUBE WELDMENT, ADJUSTABLE LEG	507715-1	1
20	FOOT	586948-1	1
21	WASHER, 21 FLAT ZINC	F81059-2	2
22	NUT, M20-8- HEX ZINC	F81037-1	2
23	WASHER, 10.5 ZC DIN 126 ISO 7091	F81055-1	4
24	BOLT, M10X25-8.8-FE/ZN5	F81003-11	2
25	NUT, M10-8-B HEX NYLON ZINC LOCK	F81033-1	4
-	COVER ASSEMBLY, MAIN TUBE	093052	1
26	WASHER, 8.4 FLAT ZINC	F81054-1	2
27	WASHER, 8.2 SPLIT LOCK ZINC	F81054-4	2
28	BOLT, M8X25-8.8-B HEX HEAD FULL THREAD Z	F81002-5	2

REF	DESCRIPTION (u indicates parts available in assemblies only)	PART #	QTY	
29	BOLT, M10X125 8.8 HEX HEAD ZINC	F81003-18	4	

8.42 Stationary Legs for "S" Frame. 526546

526546_001_B
526546_MANUAL

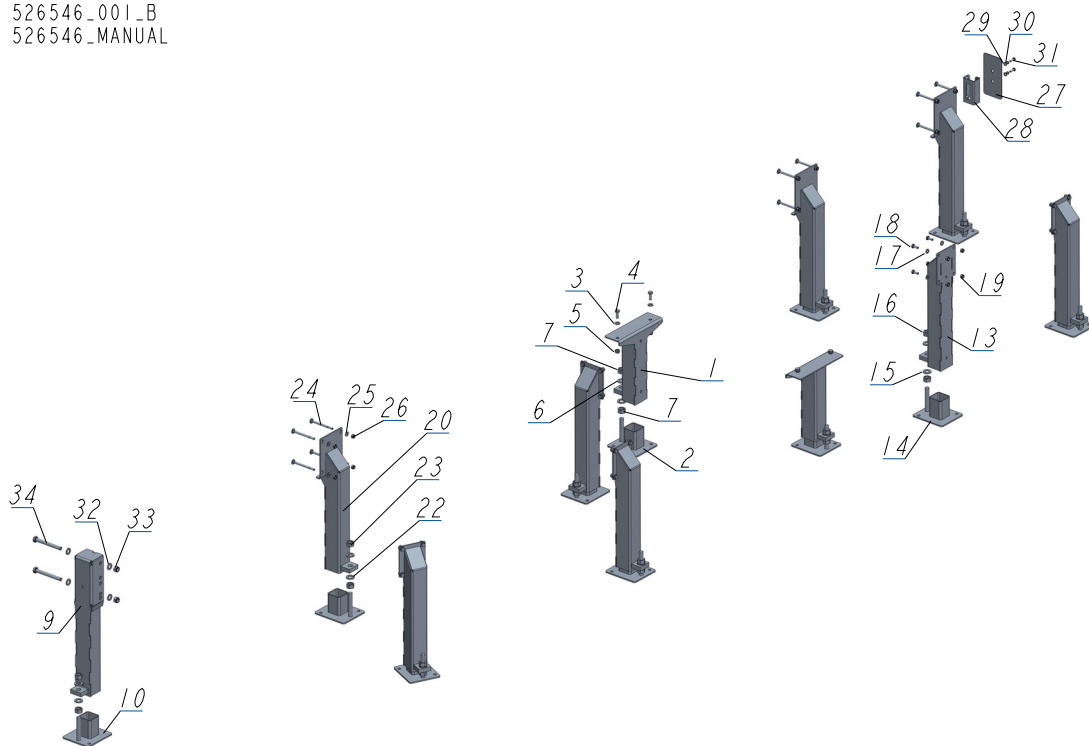

REF	DESCRIPTION (u indicates parts available in assemblies only)	PART #	QTY
-	LEG, S FRAME STATIONARY	526546	1
-	LEG, MIDDLE ADJUSTABLE STATIONARY	501637	2
1	LEG, MIDDLE	507720-1	1
2	FOOT	586948-1	1
3	WASHER, 13 FLAT ZINC	F81056-1	2
4	BOLT, M12X30 8.8 HEX HEAD FULL THREAD ZI	F81004-22	2
5	NUT, M12 8 HEX NYLON ZINC LOCK	F81034-2	2
6	WASHER, 21 FLAT ZINC	F81059-2	2
7	NUT, M20-8- HEX ZINC	F81037-1	2
8	LEG, FRONT ADJUSTABLE STATIONARY	589525	1
9	LEG WELDMENT, FRONT ADJUSTABLE	589518-1	1
10	FOOT	586948-1	1
11	WASHER, 21 FLAT ZINC	F81059-2	2
12	NUT, M20-8- HEX ZINC	F81037-1	2
-	LEG, LEFT STATIONARY ADJUSTABLE	501639	5
13	TUBE WELDMENT, ADJUSTABLE LEG	507715-1	1
14	FOOT	586948-1	1
15	WASHER, 21 FLAT ZINC	F81059-2	2
16	NUT, M20-8- HEX ZINC	F81037-1	2
17	WASHER, 10.5 ZC DIN 126 ISO 7091	F81055-1	4
18	BOLT, M10X25-8.8-FE/ZN5	F81003-11	4
19	NUT, M10-8-B HEX NYLON ZINC LOCK	F81033-1	4
-	LEG, RIGHT ADJUSTABLE STATIONARY	501640	3
20	LEG, MAIN TUBE (HIGH)	507620-1	1

REF	DESCRIPTION (u indicates parts available in assemblies only)	PART #	QTY	
21	FOOT	586948-1	1	
22	WASHER, 21 FLAT ZINC	F81059-2	2	
23	NUT, M20-8- HEX ZINC	F81037-1	2	
24	BOLT, M10X120 8.8 CARRIAGE ZINC	F81003-33	4	
25	WASHER, 10.5 ZC DIN 126 ISO 7091	F81055-1	4	
26	NUT, M10-8-B HEX NYLON ZINC LOCK	F81033-1	4	
-	COVER ASSEMBLY, MAIN TUBE	093052	1	
27	COVER, 201X101.6X3 TUBE	015023-1	1	
28	BRACKET WELDMENT, REAR MAIN TUBE COVER	087105-1	1	
29	WASHER, 8.4 FLAT ZINC	F81054-1	2	
30	WASHER, 8.2 SPLIT LOCK ZINC	F81054-4	2	
31	BOLT, M8X25-8.8-B HEX HEAD FULL THREAD Z	F81002-5	2	
32	WASHER, 17 SPLIT LOCK ZINC	F81058-1	4	
33	NUT, M16-8 HEX NYLON ZINC LOCK	F81036-2	2	
34	BOLT, M16X140 HEX HEAD ZINC GRADE 8.8	F81006-4	2	

SECTION 9 LOG CLAMP, TURNER, LOADER & TOE BOARDS

9.1 Manual Log Clamp

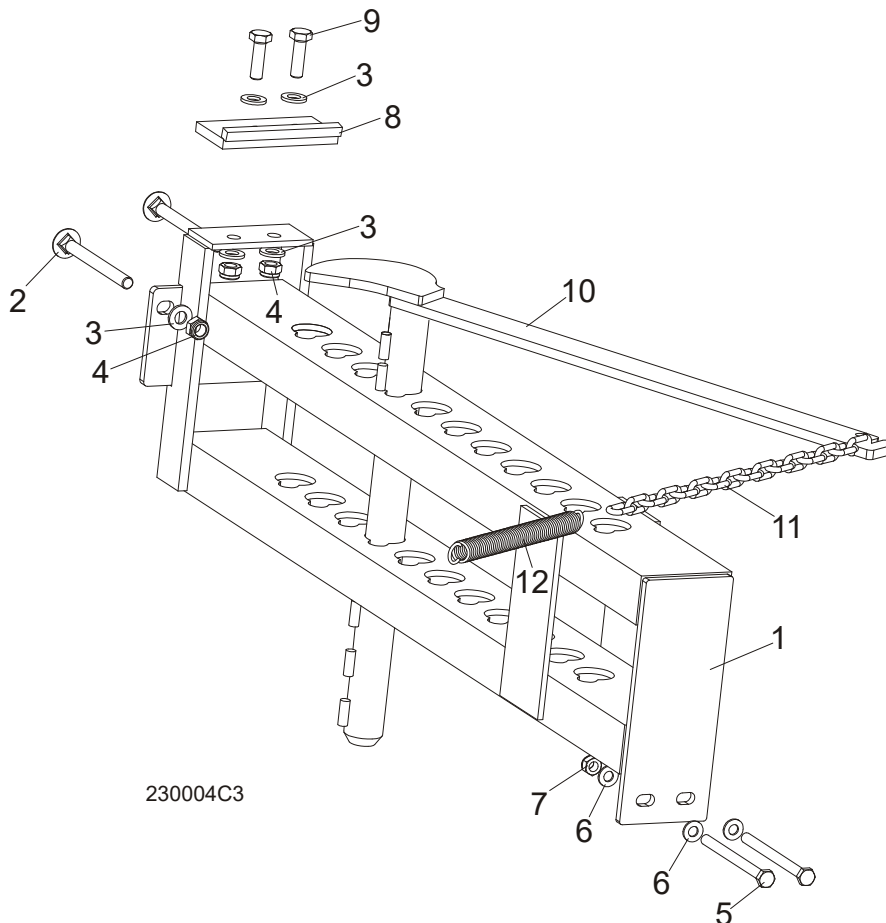

REF.	DESCRIPTION (◆ Indicates Parts Available In Assemblies Only)	PART #	QTY
	MANUAL LOG CLAMP	092683	1
1	Bracket, Manual Log Clamp	092677-1	1
2	Bolt, M12x130-8.8 Carriage Zinc	F81004-26	2
3	Washer, 13 Flat Zinc	F81056-1	6
4	Nut, M12-8 Hex Nylon Zinc Lock	F81034-2	4
5	Bolt, M10x125-8.8 Hex Head Zinc	F81003-18	2
6	Washer, 10.5 Flat Zinc	F81055-1	4
7	Nut, M10-8-B Hex Nylon Zinc Lock	F81033-1	2
8	Stop Weldment, Log Clamp	086980-1	1
9	Bolt, M12 x 40-8.8 Hex Head Full Thread Zinc	F81004-4	2
10	Log Clamp Weldment, Manual	100725-1	1
11	Chain, Log Clamp	M04311	1
12	Spring, FI 2.8 X FI 22.2 X 183	091864	1

9.2 Log Clamp Assembly

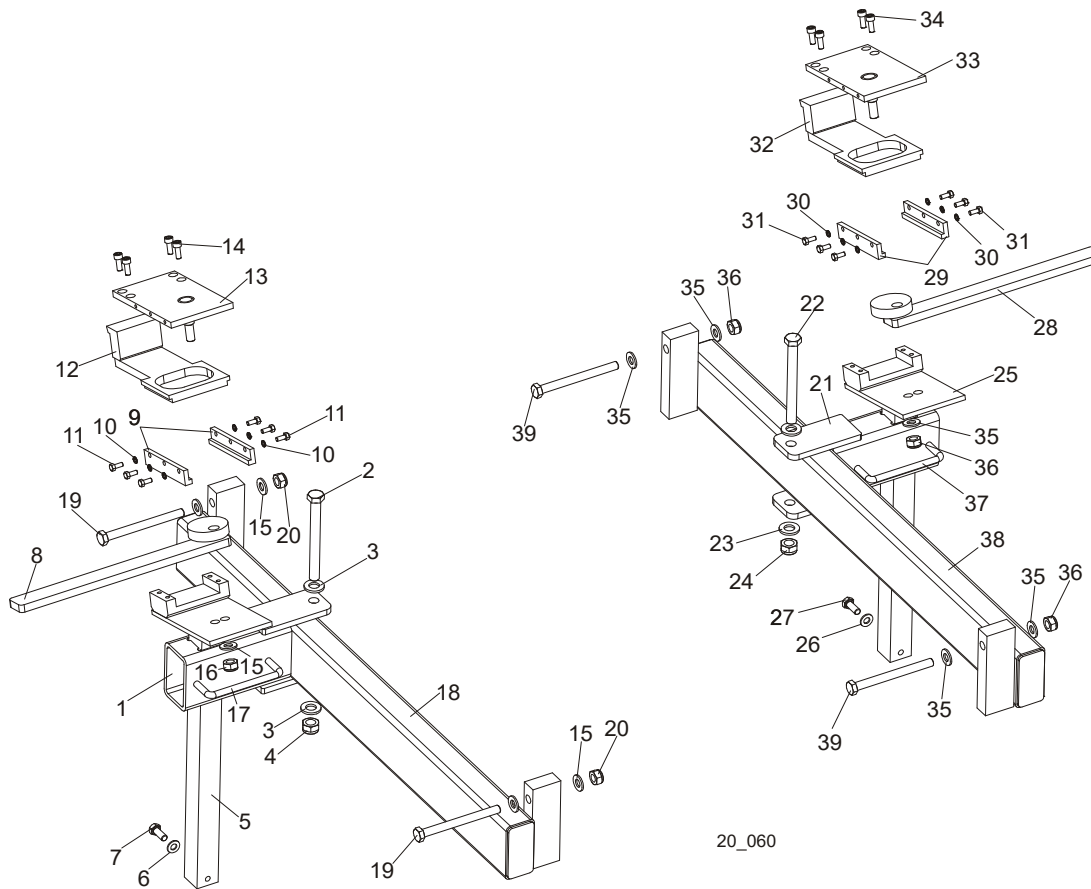

REF.	DESCRIPTION (◆ Indicates Parts Available In Assemblies Only)	PART #	QTY
	LOG CLAMP ASSEMBLY, LEFT (NON-HYDRAULIC)	089631 ¹	1
1	Arm Weldment, Log Clamp Zinc-Plated	089624-1	1
2	Bolt, M12x120 8.8 Hex Head Zinc	F81004-38	1
3	Washer, 13 Zinc Flat	F81056-1	2
4	Nut, M12-8 Hex Nylon Zinc Lock	F81034-2	1
5	Mount Weldment, Log Clamp Zinc-Plated	090174-1	1
6	Washer, 8.4 Zinc Flat	F81054-1	4
7	Bolt, M8x20-8.8-B Hex Head Full Thread Zinc	F81002-4	2
8	Lever, Log Clamp Zinc-Plated	089611-1	1
9	Plate, Log Clamp Side Zinc-Plated	089615-1	2
10	Washer, 5.1 Split Lock Zinc	F81052-2	6
11	Bolt, M5x12-5.8 Hex Head Full Thread Zinc	F81000-5	6
12	Plate, Clamping Zinc-Plated	090202-1	1
13	Plate, Log Clamp Upper Zinc-Plated	089614-1	1
14	Screw, M6x16-8.8 Hex Socket Set Cap Zinc	F81001-21	4
15	Washer, 10.5 Zinc Flat	F81055-1	5
16	Nut, M8-8-B Hex Nylon Zinc Lock	F81032-2	1
17	Handle, 4" w/Bolts	P08065	1
18	Bar Weldment, Log Clamp Guide	089628-1	1
19	Bolt, M10x110 8.8 Hex Head Zinc	F81003-43	2
20	Nut, M10-8-B Hex Nylon Zinc Lock	F81033-1	2



Log Clamp, Turner, Loader & Toe Boards

Log Clamp Assembly

	LOG CLAMP ASSEMBLY, RIGHT (NON-HYDRAULIC)	090349	1	
21	Arm Weldment, Log Clamp Zinc-Plated	089624-1	1	
22	Bolt, M12x120 8.8 Hex Head Zinc	F81004-38	1	
23	Washer, 13 Zinc Flat	F81056-1	2	
24	Nut, M12-8 Hex Nylon Zinc Lock	F81034-2	1	
25	Mount Weldment, Log Clamp Zinc-Plated	090174-1	1	
26	Washer, 8.4 Zinc Flat	F81054-1	2	
27	Bolt, M8x20-8.8-B Hex Head Full Thread Zinc	F81002-4	2	
28	Lever, Log Clamp Zinc-Plated	090348-1	1	
29	Plate, Log Clamp Side Zinc-Plated	089615-1	2	
30	Washer, 5.1 Split Lock Zinc	F81052-2	6	
31	Bolt, M5x12-5.8 Hex Head Full Thread Zinc	F81000-5	6	
32	Plate, Clamping Zinc-Plated	090202-1	1	
33	Plate, Log Clamp Upper Zinc-Plated	090347-1	1	
34	Screw, M6x16-8.8 Hex Socket Head Cap Zinc	F81001-21	4	
35	Washer, 10.5 Zinc Flat	F81055-1	5	
36	Nut, M10-8-B Hex Nylon Zinc Lock	F81033-1	3	
37	Handle, 4" w/Bolts	P08065	1	
38	Bar Weldment, Log Clamp Guide	089628-1	1	
39	Bolt, M10x110 8.8 Hex Head Zinc	F81003-43	2	

¹ The number of clamps depends on the frame length.

9.4 Manual Log Turner

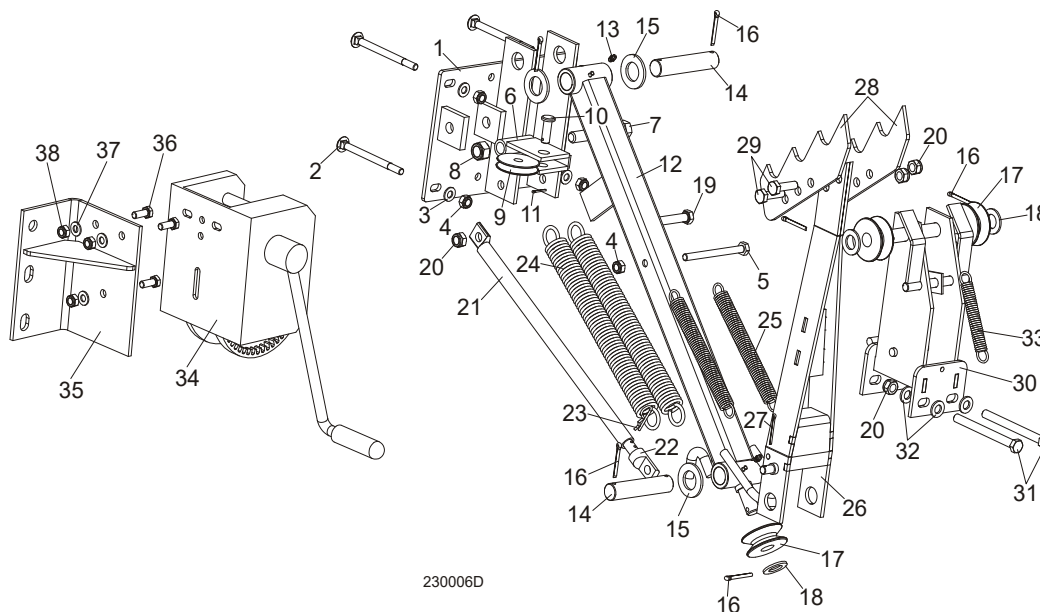

REF.	DESCRIPTION (◆ Indicates Parts Available In Assemblies Only)	PART #	QTY	
	MANUAL LOG TURNER OPTION (S/M TYPE FRAME)	091291	1	
	MANUAL LOG TURNER OPTION (L TYPE FRAME)	091562	1	
1	Bracket Weldment, Manual Log Turner (S/M Type Frame)	091269-1	1	
	Bracket Weldment, Manual Log Turner (L Type Frame)	090271-1	1	
2	Bolt, M10x120 8.8 Carriage Zinc	F81003-33	4	
3	Washer, 10.5 Flat Zinc	F81055-1	4	
4	Nut, M10-8-B Hex Nylon Zinc Lock	F81033-1	5	
5	Bolt, M10x115-8.8 Hex Head Zinc	F81003-19	1	
6	Bracket Weldment, Cable Guide Pulley	091295-1	1	
7	Bolt, M16x100-8.8 Hex Head Full Thread Zinc	F81006-2	1	
8	Nut, M16-8 Hex Nylon Zinc Lock	F81036-2	1	
9	Pulley, Zinc-Plated Cable Guide	091273-1	1	
10	Pin, 12x35 B Clevis Zinc	F81049-1	1	
11	Pin, 2.5x20 Cotter Zinc	F81043-1	1	
12	Arm Weldment, Manual Turner Lower	091256-1	1	
13	Fitting, M6 Grease	086280	2	
14	Pin, Manual Turner Arm Pivot Zinc-Plated	091275-1	2	
15	Washer, 28 Flat Zinc	F81061-1	4	
16	Pin, 5x40 Cotter Zinc	F81043-31	7	
17	Pulley, Manual Turner Zinc-Plated	091280-1	3	
18	Washer, 20.5 Split Lock Zinc	F81059-1	5	
19	Bolt, M12x120 8.8 Hex Head Zinc	F81004-38	1	
20	Nut, M12-8 Hex Nylon Zinc Lock	F81034-2	5	
21	Tube, Manual Turner Painted	091537-1	1	
22	Rod Weldment, Manual Turner	091540-1	1	
23	Pin, 1/8x1 13/16 Safety	P05059	1	
24	Spring, FI 4.5 x FI 35 x 303	091863	2	◆
25	Spring, FI 2.8 x FI 22.2 x183	091864	2	

26	Arm Weldment, Manual Turner Upper	091263-1	1	
27	Pin, 4x25 Cotter Zinc	F81043-2	1	
28	Claw, Log Turner	088082-1	2	
29	Bolt, M12x40-8.8 Hex Head Full Thread Zinc	F81004-4	2	
30	Bracket Weldment, Manual Turner Pulley	091281-1	1	
31	Bolt, M12x130-8.8 Hex Head Zinc	F81004-36	2	
32	Washer, 13 Flat Zinc	F81056-1	4	
33	Spring, FI 1.9 X FI 14.2 X 104	091865	1	
34	WINCH, AL-KO TYPE 901	096453	1	
35	BRACKET, WINCH MOUNT (COMP. NON-HYD FRAME)	085841-1	1	
36	BOLT, M10x25-8.8 HEX HEAD FULL THREAD ZINC	F81003-11	3	
37	WASHER, 10.5 FLAT ZINC	F81055-1	3	
38	NUT, M10 NYLON HEX ZINC LOCK	F81033-1	3	

9.5 Manual Toe Board

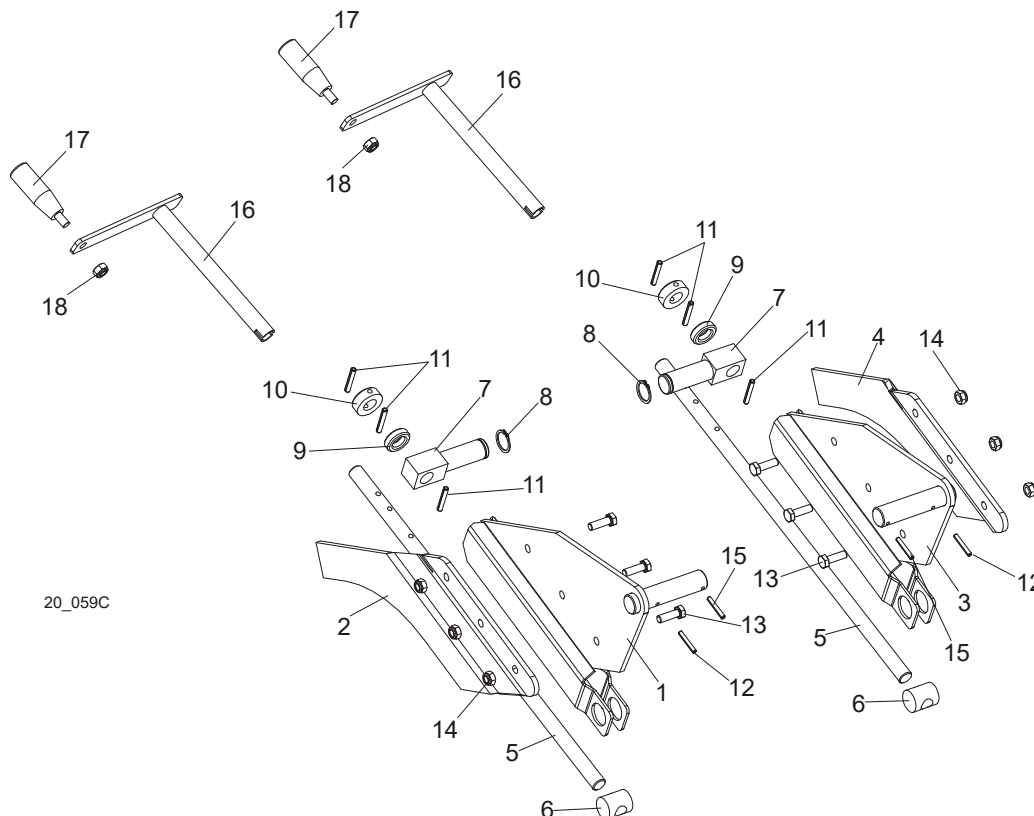

REF.	DESCRIPTION (◆ indicates parts available in assemblies only)	PART NO.	QTY
	TOE BOARD KIT, MANUAL FRONT - COMPLETE	094929	1
1	Plate Weldment, Manual Toe Board Front (S, M, L Frame)	094927-1	1
2	Extension, Manual Toe Board Plate (I)	095203-1	1
	TOE BOARD KIT, MANUAL REAR	094928	1
3	Plate Weldment, Manual Toe Board Rear (S, M, L Frame)	094926-1	1
4	Extension, Manual Toe Board Plate (II)	095202-1	1
5	Shaft, Manual Toe Board	580809-1	2
6	Nut, Special Threaded	090017	2
7	Pivot, Manual Toe Board Shaft (I)	094931-1	2
8	Ring, Z 22 Outside Retaining	F81090-24	2
9	Bearing, 5/8" Thrust	581701	2
10	Collar, 16	F81039-30	2
11	Pin, 5x35-N-C PN-EN ISO 8752 Roll	F81044-9	6
12	Pin, 4x30 roll Zinc	F81044-7	2
13	Bolt, M8x25-8.8-B Hex Head Full Thread Zinc	F81002-5	6
14	Nut, M8-8-B Hex Nylon Zinc Lock	F81032-2	6
15	Pin, S-Zn 4x25 Cotter	F81043-2	1
	CRANK ASSEMBLY, MANUAL TOE BOARD	500600	2
16	Crank, Manual Toe Board	500599-1	1
17	Knob, Plastic Crank Handle	086338	1
18	Nut, M10-8-B Hex Nylon Zinc Lock	F81033-1	1

9.6 Manual Log Loader (S/M Type Frame)

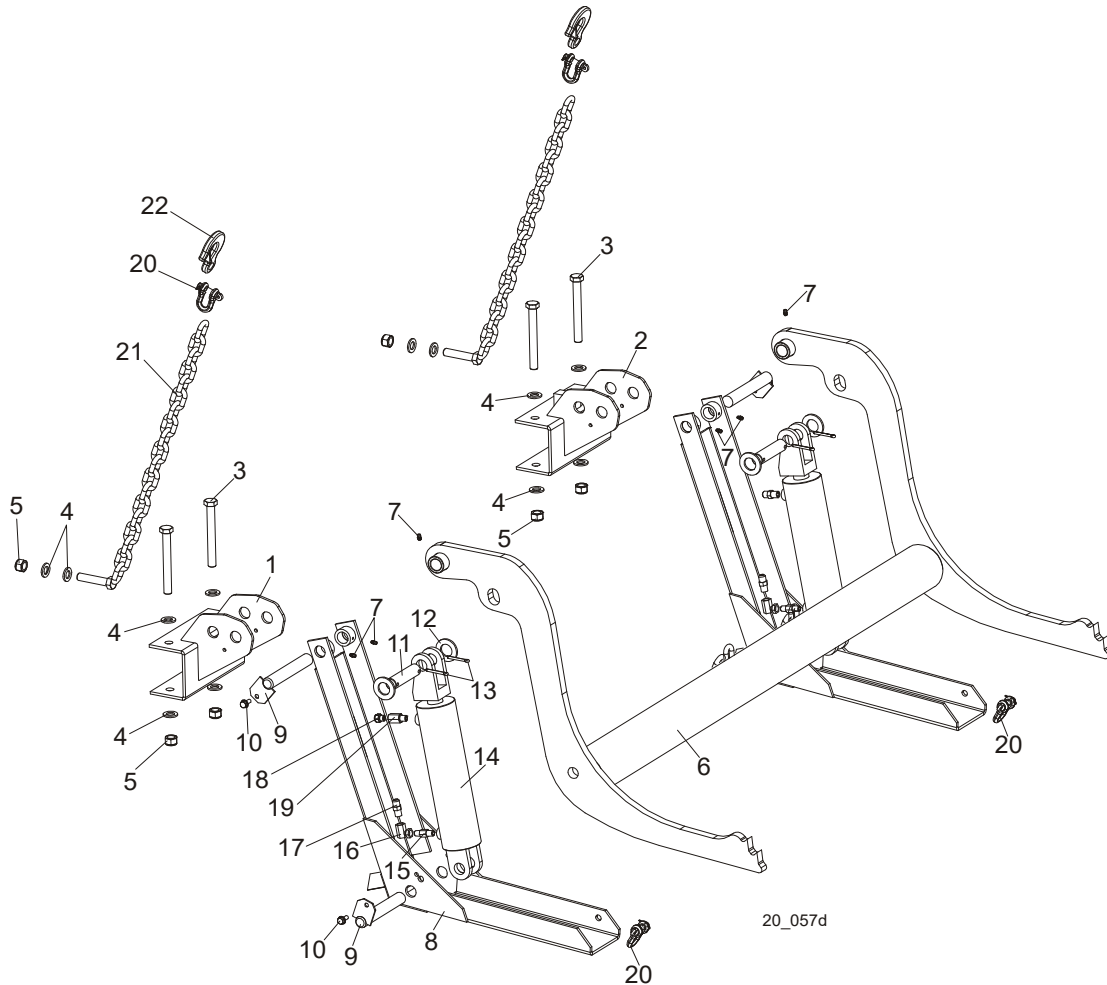

REF.	DESCRIPTION (◆ Indicates Parts Available In Assemblies Only)	PART #	QTY
	LOG LOADER, COMPLETE	091952	1
1	Bracket, Log Loader Mount Painted (S/M Type Frame)	092865-1	1
2	Bracket, Log Loader Mount	091938-1	1
3	Bolt, M16x140-8.8 Hex Head Zinc	F81006-4	4
4	Washer, 17 Zinc Flat	F81058-1	12
5	Nut, M16-8 Hex Nylon Zinc Lock	F81036-2	6
	Log Loader W/Chain	091954	1
6	Loader Weldment, Log	090006-1	1
7	Fitting, 3/16" Straight Grease	P04107	6
8	Foot, Log Loader	090048-1	2
9	Pin Weldment, Log Loader	W09446-1	4
10	Screw, 5/16-18 x 3/4 Self-Tapping	F05015-30	4
11	Pin, Hydraulic Cylinder Zinc-Plated	086979-1	2
12	Washer, 28 Zinc Flat	F81061-1	4
13	Pin, 5x40 Cotter	F81043-31	4
	Cylinder Assembly, Log Loader	094333	2
14	Cylinder, C-J-S95-16-70/32/203 Hydraulic	088680	1
15	Fitting, 1/4 NPT 4.0 GPM Velocity Fuse	015750	1
16	Fitting, #9455X4X4 90 Deg. Swivel Elbow	P12199	1

9 Log Clamp, Turner, Loader & Toe Boards

Manual Log Loader Pump

17	Fitting, 3/8JIC-1/4 NPT Straight	015560	1	
18	Air Vent Valve 2901-14-17	090794	1	
19	Fitting, $\frac{1}{4}$ " F. Thread/ $\frac{1}{4}$ " NPT M. Thread Reducer	090795	1	
20	Shackle, M-WL. .63	099525	4	
21	Chain, Log Loader Painted	091953-1	2	
22	Hook, 5/8 Safety Chain	P12075	2	

9.7 Manual Log Loader Pump

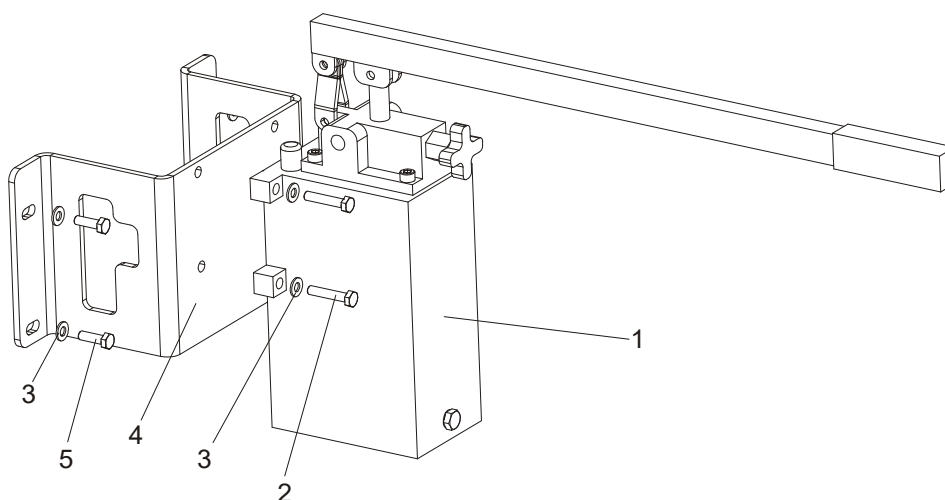

REF.	DESCRIPTION (◆ Indicates Parts Available In Assemblies Only)	PART #	QTY	
1	PUMP, PAM 014 2500 3L MANUAL	090309	1	
2	BOLT, M8X80-8.8 HEX HEAD ZINC	F81002-18	4	
3	WASHER, 8.4 ZINC FLAT	F81054-1	8	
4	BRACKET, LOG LOADER PUMP MOUNT	090377-1	1	
5	BOLT, M8X25-8.8-B HEX HEAD FULL THREAD ZINC	F81002-5	4	