

Wood-Mizer[®] SolarKiln

Safety, Construction & Operator's Manual

Model SD3000

rev. C.00

Model SD3000-50

rev. A.00



Safety is our #1 concern! Read and understand all safety information and instructions before operating, setting up or maintaining this machine.

Form #462

Table of Contents

Section-Page

SECTION 1	MATERIALS	1-1
SECTION 2	SD3000 CONSTRUCTION	2-1
2.1	Choosing A Location For The Kiln.....	2-1
2.2	Slab Construction	2-1
2.3	Sill Plate Construction.....	2-2
2.4	End Wall #1 Construction	2-2
2.5	End Wall #2 Construction	2-3
2.6	End Wall Installation.....	2-3
2.7	Front Wall Construction	2-4
2.8	Front Wall Installation.....	2-4
2.9	Back Wall Construction	2-4
2.10	Back Wall Installation	2-5
2.11	Exterior Sheathing Installation.....	2-5
2.12	Interior Sheathing/Insulation Installation.....	2-6
2.13	Support Wall Construction.....	2-6
2.14	Support Wall Installation.....	2-6
2.15	Fan Shelf Construction	2-7
2.16	Fan Shelf Plywood Installation	2-7
2.17	Loading Door Construction.....	2-7
2.18	Lower Rafter Installation.....	2-8
2.19	Upper Rafter Installation	2-8
2.20	Door Stop Installation.....	2-8
2.21	Loading Door Installation.....	2-9
2.22	Service Door Installation.....	2-9
2.23	Screen Installation	2-10
2.24	Fan Installation	2-10
2.25	Electrical Installation.....	2-11
2.26	Spacer/Furring Strips.....	2-11
2.27	Inner Plastic Installation	2-12
2.28	Outer Plastic Installation	2-12
2.29	Intake/Exhaust Hardware Installation	2-13
SECTION 3	OPERATION	3-1
3.1	Pre-Drying Procedures	3-1
3.2	Drying Procedures.....	3-3
3.3	Solar Kiln Maintenance.....	3-5

SECTION 1 MATERIALS

Congratulations on the purchase of a Wood-Mizer[®] SolarDry[®] Kiln! Enclosed are complete construction instructions for the kiln. This manual contains drawings and lists of building materials required to construct the SolarDry SD3000 SolarKiln. **Follow the instructions carefully, strictly heeding all special WARNINGS and NOTES.**



IMPORTANT! Before beginning construction, check your local building code authority to see if a building permit is required.

See Table 1-1. Open the box and identify all parts listed below:

SD3000/SD3000-50 Box Assembly		
Qty.	Part No.	Description
13	002681	Strip, 3í-6" Aluminum/Rubber
6	002685	Cap, 4í Aluminum Drip
2	002688	Bolt, 24" Chain Release Door
2	002690	Bolt, 12" Cane Bottom Steel
2	002693	Handle, 6" Galvonized Door Pull
1	002694	Knob Assy, 1 3/4" Door
2	002695	Panel, 12" x 12" Wall Grill
3	002680	Hinge, Door
4	002696	Hinge, 6" x 36" x 3/8" Pin Steel
2	002684	Bracket Assembly, Fan Mount
2	P02549	Blade, 24" Three Wing Fan
2	P02646	Motor, 1/4Hp Fan (SD3000)
	P02646-1	Motor, 50Hz 1/4Hp Fan (SD3000-50)
8	F05010-41	Nut, #8-32 Self-Locking Fan Motor
1	A02583	Door, Aluminum Air Intake
2	002706	Plastic, 20í x 24í 6 mil UV
4	002699	Guard, Expanded Metal Fan
1	SD3000-462	Manual, SD3000 Const./Operation

TABLE 1-1

1

Materials

See Table 1-2. Required materials to be supplied by the customer for the SD3000 SolarDry Kiln are listed below.

Material	End walls (2)	Front Wall	Back Wall	Support Wall	Rafters	Fan Shelf & Baffles	Loading Doors	Furring Strips & Door Stops	Total Qty
1î x 2î x 10î Cedar								18	18
1" x 4" x 10î							9		9
1î x 4î x 14î				2					2
2" x 2" x 10î								23	23
2" x 4" x 8î	11	2	14			13	3		43
2" x 4" x 10î	10			10	10	4	14		48
2" x 4" x 12î	6								6
2" x 4" x 14î	6				10				16
2" x 4" x 16î	6		2						8
2î x 4î x 20î			3						3
2" x 4" x 10î Treated		2		2					4
2" x 4" x 16î Treated	2								2
2î x 6î x 20î		1		1					2
4î x 8î x 1/2" BCX Plywood	20	2	10			6			38
4î x 8î x 1/4" BCX Plywood							10		10
4" x 16" Kraft Fiberglass Insulation									550 Sq Ft.
Foam Sill Seal/Insulation									50 Ft.
2î-8î x 6î-8î x 1 3/4î Solid Core Door									1
16D Sinker Nails									1 box
7D Galvanized Nails									1 box
3î Drywall Screws									1 box
1/4" x 2" Hex Head Lag Screws							40		40
8î Concrete Anchors, Washers, & Nuts									22
Black Kiln Coat Paint									3 Gal.
Exterior Paint (Customer Choice)									2 Gal.
Concrete (Slab & Loading Apron)									7.5 yds.
22î x 20î x 4 mil Black Plastic									1
6î x 6î x 10 Gauge wire mesh (remesh)									304 Sq Ft.
20 Amp Disconnect Switch									1
10 Oz. Tube Black Acrylic Latex Caulk									4
Standard Screen Door Mesh									213 Sq Ft.

TABLE 1-2

See Table 1-3. A list of suppliers for some materials are listed below.

Product	Name	Supplier
Log End Coating	Anchorseal	U.C. Coatings, Corp. P.O. Box 1066 Buffalo, N.Y. 14215 (716) 833-9366
Kiln Coating	Black Jack 6383 (Distributed by Grainger, Menards & Target)	Gibson-Homans Co. 1755 Enterprise Parkway Twinsburg, OH 44087 1 (800) 433-7293
	Kiln Seal	Texas Refinery Corp. One Refinery Place Fort Worth, TX 76106 (817) 332-1161
Moisture Meters	Wagner L606	Wood-Mizer Products, Inc. 8180 West 10th Street Indianapolis, IN 46214 1 (800) 525-8100

TABLE 1-3

See Table 1-4. A list of recommended books concerning lumber drying is provided below.

Publication	Supplier
Wood Handbook	AH No. 72, USDA Forest Service, Forest Products Lab, Madison, WI, 1955; (608) 231-9200
Dry Kiln Operator's Manual	AH No. 188, E.F. Rasmussen, USDA Forest Service, Forest Products Lab, Madison, WI 1988 (Stock No. 001-000-04576-8); (202) 512-1800
Understanding Wood, A Craftsman's Guide to Wood Technology	R. Bruce Hoadley, available from Wood-Mizer (Part No. P05877)

TABLE 1-4

SECTION 2 SD3000 CONSTRUCTION

2.1 Choosing A Location For The Kiln

Some considerations should be made when choosing a location for your SolarDry Kiln:

Build the kiln so the collector faces within 5 degrees of due south if building in Northern latitudes. If you are building in Southern latitudes face the kiln within 5 degrees of due north. Use a compass to determine the best position for your kiln.

Build the kiln in an area to avoid nearby obstructions of the sun if possible. Allow enough room around the kiln to maneuver a fork lift or other handling equipment used to move lumber piles.

Consider future expansion. Additional kilns may be added so they may share end walls with the first one constructed.

2.2 Slab Construction

[Refer to Drawing #1.](#)

The recommended slab has a 6" base which thickens to 18" around the edge. Place concrete wire mesh across the entire base and a 1/2" reinforcing rod around the perimeter. This creates an extremely stable, sturdy base. Install a black 16í x 20í 4 mil. plastic vapor barrier under the slab. Save the remaining 6í x 20í plastic to use as a baffle between the fan shelf and top of the wood stack. [See Section 3.2.](#)

The slab should taper 1" front to back to allow any moisture in the kiln to drain out the loading door side of the kiln.



IMPORTANT! The slab must be level, square and the exact length shown. If the slab is not level and square, the chamber will not line up properly and adjustments in constructing the chamber will have to be made.

Install anchor bolts in the slab for mounting the sill plates at the locations shown. Leave the anchor bolts exposed 2" above the slab to mount the sill plates.

A 10-foot loading apron on the back side of the kiln is recommended to facilitate loading equipment. The apron should taper 1" from front to back. Leave a 1/4" to 1/2" expansion joint between the apron and the slab.

After the concrete slab has had sufficient time to cure, you may begin construction of the kiln chamber.

2.3 Sill Plate Construction

[Refer to Drawing #2.](#)

Chalk a line 4" from each edge of the slab. Check the marked lines for squareness.

NOTE: If the lines show the slab is not square, make adjustments at this time.

Cut the sill plates out of treated lumber to the dimensions shown. Use a 16-foot treated 2x4 for each end wall sill plate. Use two 10-foot treated 2x4s for the front and middle wall sill plates.

Lay the sill plates in place on the slab. Mark and drill 3/4" diameter holes for the anchor bolts.

Remove the sill plates and use them in wall construction as described later.

2.4 End Wall #1 Construction

NOTE: These plans assume you will install the service door in end wall #2 (right side as you are facing the kiln). If you prefer the door to be on the left side, simply reverse the position of the end walls on the slab. You will have to place the lead-in boards for the middle wall on the opposite side as shown in the drawings.

[Refer to Drawing #3.](#)

Refer to the material table and cut lumber as shown. Construct the end wall as shown. Be sure to keep the sill plate oriented so the holes will line up with the slab anchor bolts.

Install the end studs to the sill plate using 16D nails.

Install the first 45° cap. If two boards are used, position the seam over the lead-in as shown.

After squaring the wall, mark the stud locations on the sill and the cap. Install the vertical studs, being sure to keep the wall square.

Install the three studs that make up the lead-in for the interior wall. Be sure the middle lead-in board is aligned with the inside face of the wall.

Install nailers between the vertical studs for mounting plywood sheathing.

Box in the area near the short end of the wall as shown for the air intake hole.

Install the top 45° cap, being sure to offset the seam with the bottom cap seam.

2.5 End Wall #2 Construction

[Refer to Drawing #4.](#)

Refer to the material table and cut lumber as shown. Build the second end wall using the same procedure used to build the first end wall.

The middle lead-in board should be on the inside of the wall. Frame an area for the service door.

2.6 End Wall Installation

[Refer to Drawing #5.](#)

Install sill seal foam or silicon caulk on the bottom of the wall sill plates and place each end wall in position on the slab. Be sure the inside of the wall sill plate lines up with the chalk lines on the slab to maintain squareness.

Secure the end walls to the slab anchor bolts with washers and nuts. Brace the walls as needed to keep them square.

2.7 Front Wall Construction

[Refer to Drawing #6.](#)

Refer to the material table and cut lumber as shown.

Build the front wall as shown. Install the end studs using 16D nails.

Cut the top plate from 2x6 lumber and install. Square the frame and mark the stud locations on the sill plate and top plate.

Be sure to keep wall square while installing the vertical studs.

2.8 Front Wall Installation

[Refer to Drawing #7.](#)

Install sill seal foam or silicon caulk on the bottom of the wall sill plate and place the front wall in position on the slab. Be sure the inside of the wall sill plate lines up with the chalk lines on the slab to maintain squareness.

Secure the front wall to the slab anchor bolts with washers and nuts. Brace the wall as needed to keep it square. Secure the front wall to the end walls using 3" drywall screws.

2.9 Back Wall Construction

[Refer to Drawing #8.](#)

Refer to the material table and cut lumber as shown. The outer end studs are turned horizontally to match the end walls. Install the first top plate and door header and square the frame.

Check that the wall is square and mark the vertical stud locations on the door header and top plate.

Cut and install vertical studs. Cut and install angled trusses and frame an area as shown for the air exhaust.

Install the top plate.

2.10 Back Wall Installation

[Refer to Drawing #9.](#)

Cut spacers from 1/2" plywood and secure to the end wall studs.

Install 6 pieces of drip edge to the back side of the door header. Position the drip edge so it points out to the rear of the wall (See detail). Overlap the pieces a few inches and secure with 7D nails.

While keeping the wall square, install the 1/2" plywood sheathing to the exterior side of the wall using 7D nails. Apply caulk between all plywood joints. The plywood will overhang the ends of the wall by 1/2".

Place the back wall in position against the end walls. Brace the wall as necessary to keep it square. Secure the back wall to the end walls using 3" drywall screws. All walls should now be secured to the slab, level, and braced from the interior.

2.11 Exterior Sheathing Installation

[Refer to Drawing #10.](#)

Install drip edge above the service door opening.

Install 1/2" exterior sheathing to all the walls with 7D nails. Apply caulk between all plywood joints. Cut the top of the front wall exterior plywood at 45° as shown.

Be sure to cut holes where required for the intake and exhaust openings.

2.12 Interior Sheathing/Insulation Installation

[Refer to Drawing #11.](#)

Remove all wall bracing from the interior of the kiln chamber.

Install 4" x 16" kraft-faced fiberglass insulation in the walls between each stud. Place the insulation so the paper face is toward the interior of the kiln to create a vapor barrier.

Install the interior plywood using 7D nails. Cut the top edge of the interior back wall plywood at 45°. Caulk all joints between plywood panels. Be sure to cut holes for the intake and exhaust openings.

2.13 Support Wall Construction

[Refer to Drawing #12.](#)

Refer to the material table and cut lumber as shown. Build the support wall as shown. Install the end studs to the sill plate using 16D nails.

Cut the top plate from 2x6 lumber and install. Square the frame and mark the stud locations on the sill plate and top plate.

Be sure to keep wall square while installing the vertical studs.

2.14 Support Wall Installation

[Refer to Drawing #13.](#)

Place the support wall in position on the slab.

Secure the interior wall to the slab anchor bolts with washers and nuts. Level the wall and secure it to the end walls using 3" drywall screws.

Install the 1x4 cross braces with 7D nails.

2.15 Fan Shelf Construction

[Refer to Drawing #14.](#)

Refer to the material table and cut lumber as shown. Build the fan shelf as shown. Install outside plates to interior kiln walls using 16D nails. The bottoms of the plates should align with the bottom angle of the support wall (see detail).

Mark locations for the studs on the outside plates. Cut and install studs and bracing for fans.

2.16 Fan Shelf Plywood Installation

[Refer to Drawing #15.](#)

Cut and install 1/2" plywood to top of fan shelf with 7D nails. Cut 25" diameter holes in two of the plywood sheets so the holes will be centered in the framed fan boxes.

2.17 Loading Door Construction

[Refer to Drawing #16.](#)

Refer to the material table and cut lumber as shown. Build two loading doors as shown, using 16D nails. Layout bottom, top, and side pieces. Use double studs at the outside end of each door to enable hinge mounting later. Mark the ends with the double studs so you can identify this end after the plywood is installed.

Mark the stud locations on the top and bottom plates. While keeping the frame square, nail in the studs.

NOTE: 2x4s are used where plywood seams will meet. Use 1x4s at all other locations to reduce the weight of the doors.

Install nailers where shown to aid in plywood installation. The nailers at the inside bottom of each door will provide a mounting location for the door hardware later.

While keeping the doors square, install the exterior 1/4" plywood using 7D nails. Caulk all plywood joints.

Install insulation between the studs of each door so the paper will face the interior of the kiln (see detail).

Install the interior 1/4" plywood with 7D nails. Apply caulk between all plywood joints. Mark the doors to identify which is the interior side and set the doors aside to be installed later.

2.18 Lower Rafter Installation

[Refer to Drawing #17.](#)

Cut rafters as shown. Mark rafter locations on front wall and interior wall headers.

Set rafters in place and secure with 16D nails. The end rafters should be placed against the inside of the end walls.

2.19 Upper Rafter Installation

[Refer to Drawing #18.](#)

Cut rafters as shown. Mark rafter locations on the back wall header.

Set the rafters in place so they align with the lower rafters and the marks on the back wall header. Secure the rafters to the interior and back walls with 16D nails.

2.20 Door Stop Installation

[Refer to Drawing #19.](#)

Cut and install 1x2 cedar door stops for loading and service doors as shown. Use 7D nails to secure stops to inside back wall and service door frame.

2.21 Loading Door Installation

[Refer to Drawing #20.](#)

Install 36" hinges to back wall as shown. The top set of hinges should be 2" from the top of the door opening. The bottom set of hinges should be 10" from the bottom of the door opening. Mark the mounting hole locations for the hinges and drill 3/16" diameter holes. Secure the hinges to the back wall with 1/4" x 2" lag screws.

Place the doors in position being sure to place the ends with double studs toward the outside and the interior face toward the inside of the kiln. Shim the bottom of the doors so there is an 1/8" gap between the door and the wall at the top and the outside.

Drill 3/16" diameter mounting holes and secure hinges to doors with 1/4" x 2" lag screws.

Swing the doors open and check for proper operation. Close the doors and position the 1x4 stop so it is centered across both doors. Secure the 1x4 to one door with 7D nails.

Install weather-stripping along the inside and bottom edges on the interior side of each loading door.

2.22 Service Door Installation

[Refer to Drawing #21.](#)

See Figure 2-1. Cut and install the service door as shown.

NOTE: Drip cap above service door should have been installed with exterior sheathing.
[See Section 2.11](#)

Follow the manufacturer's instructions for installing the door hinges and the door knob assembly provided.

Install weather-stripping along the inside bottom edge of the service door.

2.23 Screen Installation

[Refer to Drawing #22.](#)

Install the door screen to the bottom of the rafters. Cover the entire area between the middle support wall and front wall (18' - 6" x 11' - 6"). Use staples to secure the screen to the rafters.

Paint all interior kiln surfaces including plywood, fan shelf, support wall, and the slab floor with solar kiln black paint.

Paint the exterior walls any color you choose. Light colors are recommended for the outside of the kiln as they will reflect solar heat to the collector.

2.24 Fan Installation

[Refer to Drawing #23.](#)

Install a fan mount bracket centered in each hole in the fan shelf. Use 1/4" x 2" lag screws to secure each bracket flush with the 2x4 fan shelf members.

Mount a fan motor to each bracket using four #8-32 hex nuts. Position the motor so the wires face toward the rear of the kiln.

Connect the fan motor leads (brown wires with flag terminals) to the capacitor on the mount bracket.

Place a fan blade on each motor with the hub toward the motor. Secure the blade to the motor shaft by tightening the set screw in the blade hub.

Install expanded metal guards on both sides of the fan mount bracket. Use 7D nails to secure the screen to the bottom of the fan shelf.

2.25 Electrical Installation



DANGER! Hazardous voltage will cause severe shock, burns, or death. Disconnect and lock out all power to the equipment before connecting wires. Make sure all electrical installation is performed by a qualified electrician in accordance with applicable electrical codes.

[Refer to Drawing #24.](#)

Install a 20 amp disconnect switch on either end wall near the rear of the kiln.

Wire the switch and fans according to the diagram provided. Route all wiring and/or conduit beneath the fan shelf. Secure the wiring so it does not hang down into the lumber chamber where it could be damaged during loading or unloading.

Finally, install appropriate incoming power to the disconnect switch. Turn the switch ON and check the fans blow air upward. If a fan is not blowing upward, turn the disconnect switch off. Lock and tag the switch before performing any electrical service to the kiln.

Refer to the wiring diagram on the motor and rewire as necessary for proper fan rotation.

NOTE: Although only 230 Volt power is required to operate the fans, you may wish to have 115 Volt installed so you have power available for lights, tools, etc...

2.26 Spacer/Furring Strips

[Refer to Drawing #25.](#)

Cut all 2x2 spacers and 1x4 furring strips as shown and paint solar kiln black.

NOTE: If you do not have tools to create the notched 2x2 spacer (D), it may be constructed using small 1x2 blocks fastened to a single 1x2.

2.27 Inner Plastic Installation

NOTE: Close all doors to the kiln before installing plastic.

[Refer to Drawing #26.](#)

Install one of the 20' x 24' plastic sheets over the kiln as shown. Position the plastic so it hangs evenly over each side of the kiln.

Start at the top of the kiln and secure across the top with 2x2 spacers as shown. Be sure to keep plastic flat and remove any folds before securing spacers.

After securing the plastic across the entire length of kiln at the top, install spacers down each end wall.

Pull the bottom of the plastic over the front wall and secure the notched spacers over the bottom ends of the plastic. Position the spacers so the notched openings face the kiln wall. The notches will provide an area where moisture can escape.

Install spacers up the length of each rafter as shown.

HINT: Start at the bottom of the rafters first. After the first sections are installed, 2x4s can be temporarily attached across the kiln to use as steps. Install steps as you progress up the rafters.

2.28 Outer Plastic Installation

[Refer to Drawing #27.](#)

Lay the second 20' x 24' sheet of plastic over the kiln. Start from the top and position the plastic so it hangs evenly over all edges.

Stretch the top of the plastic tight and install the outside furring strips across the top of the back wall first.

Stretch the plastic tight and secure outside furring strips down the sides of each end wall.

Pull the top of the plastic tight and install the inside furring strips across the top of the kiln.

Pull each side of the plastic tight and install the inside furring strips down each side of the kiln.

Finally, stretch the plastic down over the notched 2x2 spacers at the bottom of the kiln and secure to the front wall with furring strips 1" down from the notched 2x2 spacers. The inner and outer layers of plastic should form a channel where moisture can drain out.

2.29 Intake/Exhaust Hardware Installation

[Refer to Drawing #28.](#)

Install a louvered grill over the outside of the intake hole in the end wall and the exhaust hole in the back wall.

Mount the intake damper over the intake hole from inside the kiln. Drill holes in the damper as necessary to mount securely to the wall.

SECTION 3 OPERATION

Your Wood-Mizer^{AE} SolarDry^o Kiln is the simplest, most energy efficient dry kiln available. It will give you many years of service with very little maintenance.

The following steps are necessary to maintain the expected levels of less than 1% drying defects.

3.1 Pre-Drying Procedures

- End coat the logs.

End coat the logs with an oil base paint or a commercial end-coat. End coating the logs will prevent the ends from splitting.

The best time to end coat is before the logs are sawn. The next best time is when the lumber is dead stacked, before stickering.

- Air dry the lumber.

Air drying your lumber before loading it into the kiln can cut kiln drying time in half. Keep the lumber stack at least 6" off the ground and protect both outer ends from morning and evening sun with plastic, burlap, or plywood, etc.

Most species can be loaded into the kiln right off the saw but some woods are naturally prone to staining and require at least a few days of air-drying to get rid of excess surface moisture before loading in the kiln.

Other common air-drying defects such as checking, honeycomb, splits, and warp can be controlled by using proper air-drying procedures. (See recommended reading list in Section 6.)

- Sort and sticker the lumber.

Sort the lumber to be dried according to thickness and species. While it is best to load the kiln with the same thickness and species, it is not always possible.

Most hardwoods can be dried together with the exception of the oaks and other slower drying woods such as hickory and beech.

As a rule of thumb you can sort lumber by weight or density. Lighter density woods like basswood, butternut, and aspen can be dried together. Medium density woods such as cherry, walnut, and ash and dense woods like red oak, white oak, and beech can be dried together.

If you do mix species, put the quicker drying ones at the top so they can be unloaded when dry and leave slower drying species to continue drying. This also applies to different thicknesses of lumber in the same load. Place the slowest drying thickness on the bottom.

Use wood spacers or "stickers" between the layers of wood when air drying or solar kiln drying.

Use air-dried stickers that are 3/4" x 3/4" x 4' long. Stickers should be straight and square. Stickers smaller than 3/4" will cause increased drying times. Place stickers between the layers of wood about 16-24" apart. Add stickers where needed to make sure no boards overhang stickers by more than a few inches.

Place stickers at the ends of the lumber stack to minimize end splitting.

Build layers of the stack starting with the outside edges. Group boards in a layer to minimize gaps between the boards.

Alternate gaps in each layer throughout the stack.

Keep the pile square and level with all stickers aligned vertically.

3.2 Drying Procedures

- Load the kiln.

Open the loading doors.

Load the lumber into the kiln. Leave a minimum air space of 12 inches between the load and the back wall of kiln chamber.

Block the air spaces between wood stacks with plywood, crushed newspaper, or plastic so that all air flow is directed through the stickered lumber.

If loads are more than 3/4" off the floor, add spacers to narrow the gap to 3/4".

Hang plastic (preferably black) from the fan shelf across the entire length of the kiln. Drape the plastic down on top of the lumber stack and secure with concrete bricks or heavy blocks.

See Figure 3-1.

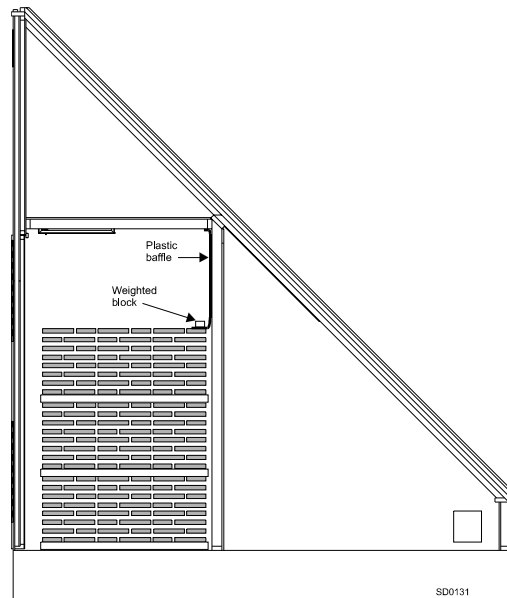

FIG. 3-1

Close the loading doors, service door, and intake damper.

- Circulating fans.

After the kiln warms up, turn the circulating fans on at the main switch.

- Intake damper.

Adjust the intake damper so the wood dries slow enough to avoid degrade. Thicker stock will require a lower maximum drying rate than thinner stock. Different species also will require different maximum drying rates. Consult the Dry Kiln Operator's Manual (USDA Forest Products Service, Publication 88) and Dry Kiln Schedules for Commercial Woods, Temperate and Tropical (USDA Forest Products Laboratory, General Technical Report FPL-GTR-57) for details.

The intake damper should be adjusted so no more than 2% moisture content per day is removed until the lumber reaches 30% moisture content.

NOTE: Nearly all lumber degrade (surface checks and honeycomb) occur in the first 15% of the drying schedule.

- Monitor moisture content of lumber.

To most easily, rapidly, and accurately determine the moisture content of the lumber, use a moisture meter.

Go in the kiln and sample several representative boards. When readings are around 10%, take one of the wettest sample boards out of the kiln and test again after it cools. Moisture meters are only effective below 25% moisture content.

One alternate method of measuring moisture content is the standard oven-dry method (see Dry Kiln Operator's Manual - USDA Forest Service AH No. 528). This is the only accurate method of measuring moisture content above 25%.

You must use the oven-dry method during initial drying stages until desired drying schedule for specific thickness and species is established. Damage can occur during these initial stages which will create honeycomb and other degrades.

- Unload the kiln.

When the wood reaches the desired moisture content, use the disconnect switch to turn off the circulating fans.

Open the loading doors and unload the kiln. Store stickers in a covered bin to keep them dry. Wet stickers will stain the lumber being dried.

3.3 Solar Kiln Maintenance

1. Replace the collector cover at the first sign of age cracking, approximately every 2-4 years. It is advisable to keep a spare cover around at all times in case of emergency.
2. Small tears or holes in the collector plastic can be repaired with silicone caulk and a small piece of kiln plastic.
3. Occasionally check the internal kiln wiring for deterioration. Replace as needed.



DANGER! Components of electrically-powered equipment contain hazardous voltage that can cause shock, burns, or death. Keep all component covers closed and securely fastened during equipment operation.

Disconnect and lock out all electrical power to the equipment before servicing. Make sure all electrical service and/or maintenance work is performed by a qualified electrician and is in accordance with applicable electrical codes.

4. Lubricate the fan motors every time you load the kiln. Locate the oil holes and apply 2-3 drops of 20 weight machine oil.
5. Repaint the interior of the kiln chamber as needed.
6. Keep the inside of the kiln clean. Dirt and dust inside the chamber can circulate and settle in the collector, making it less effective in gathering solar energy.

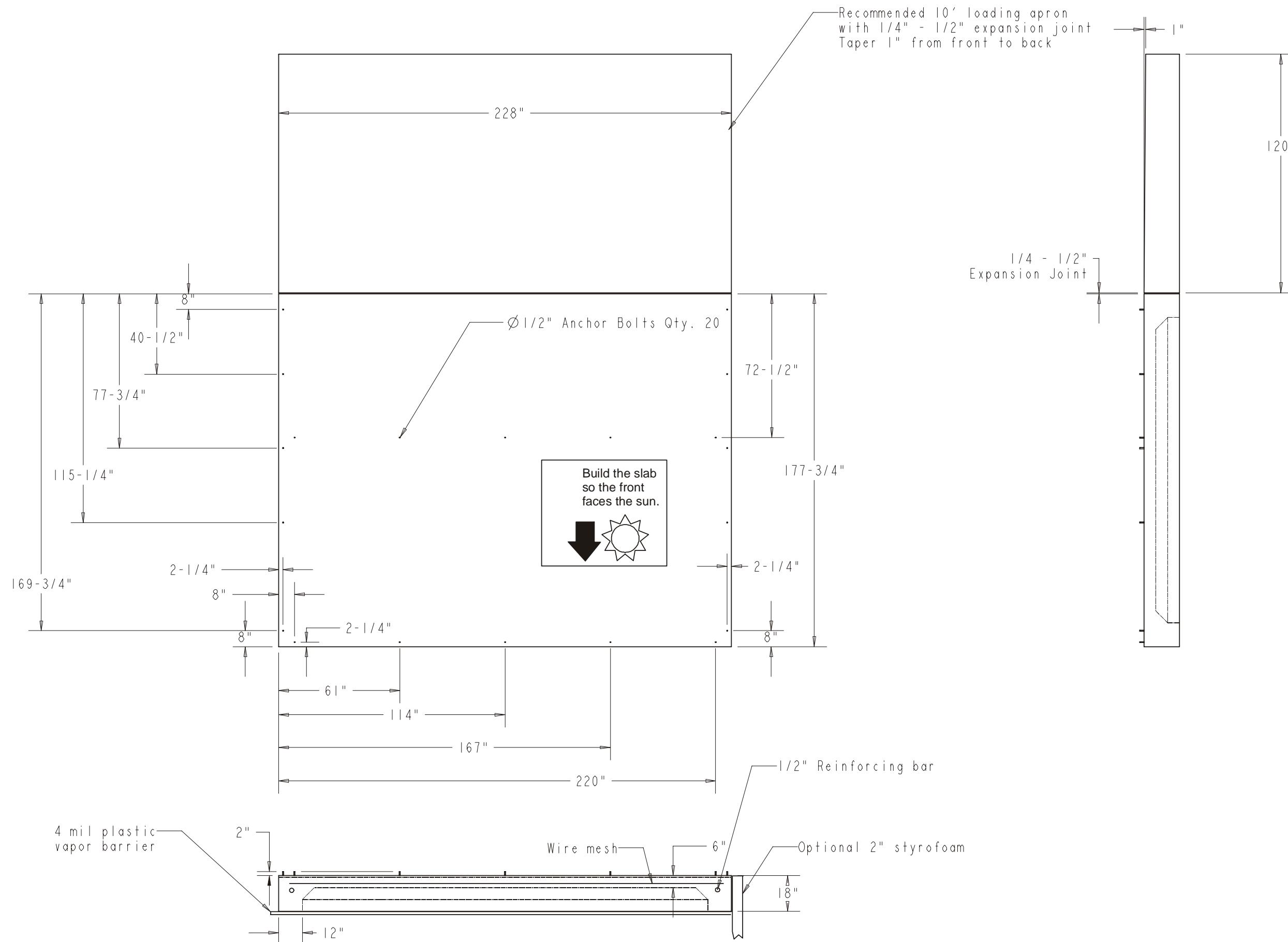

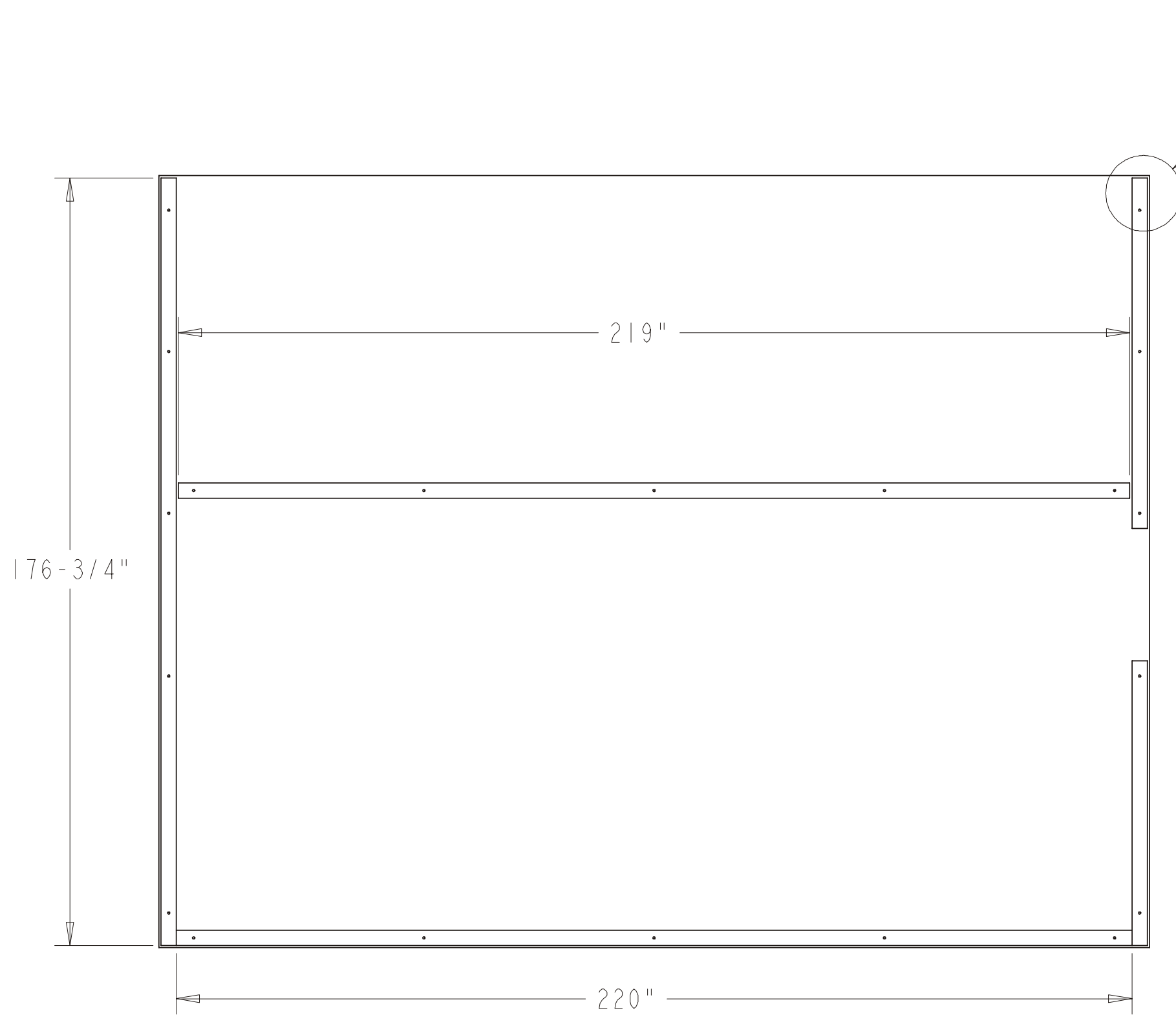

SEE DETAIL #1

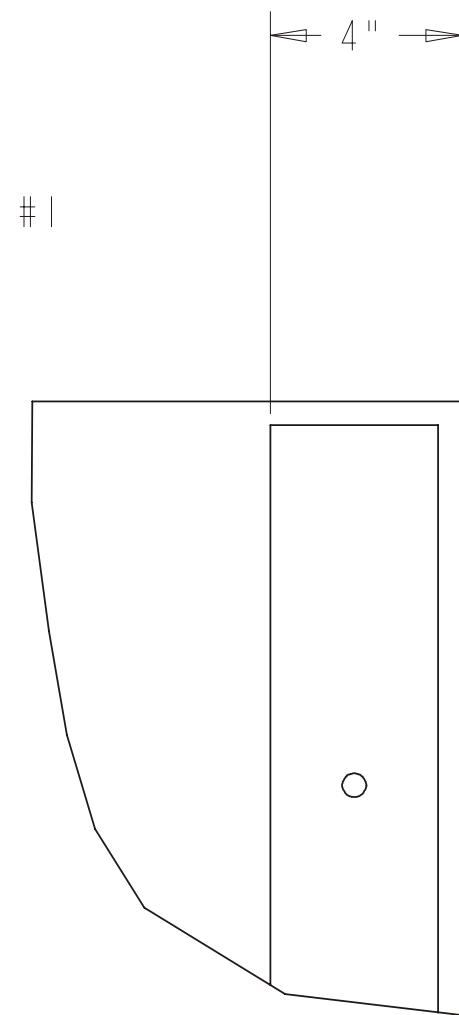

DETAIL #1
SCALE 0.250

NOTE: See table for
lumber lengths

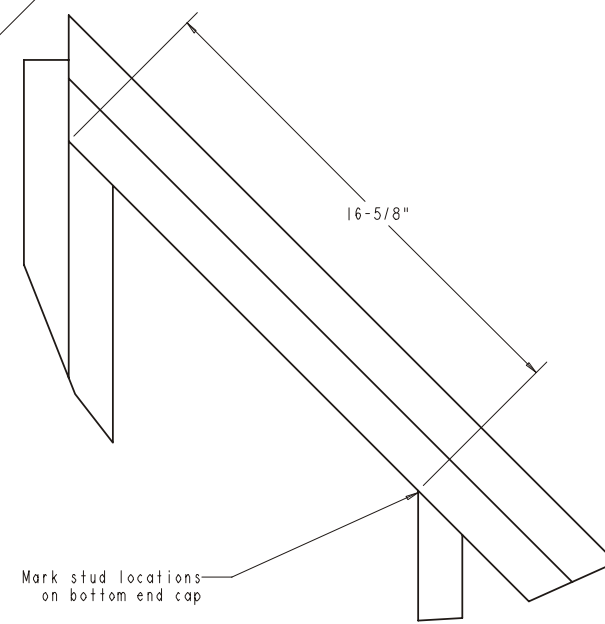
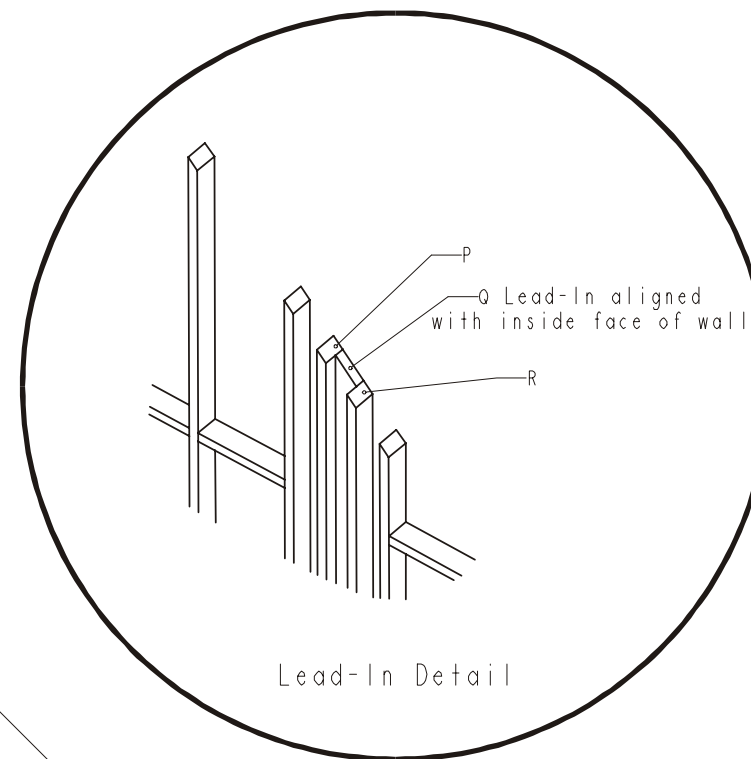
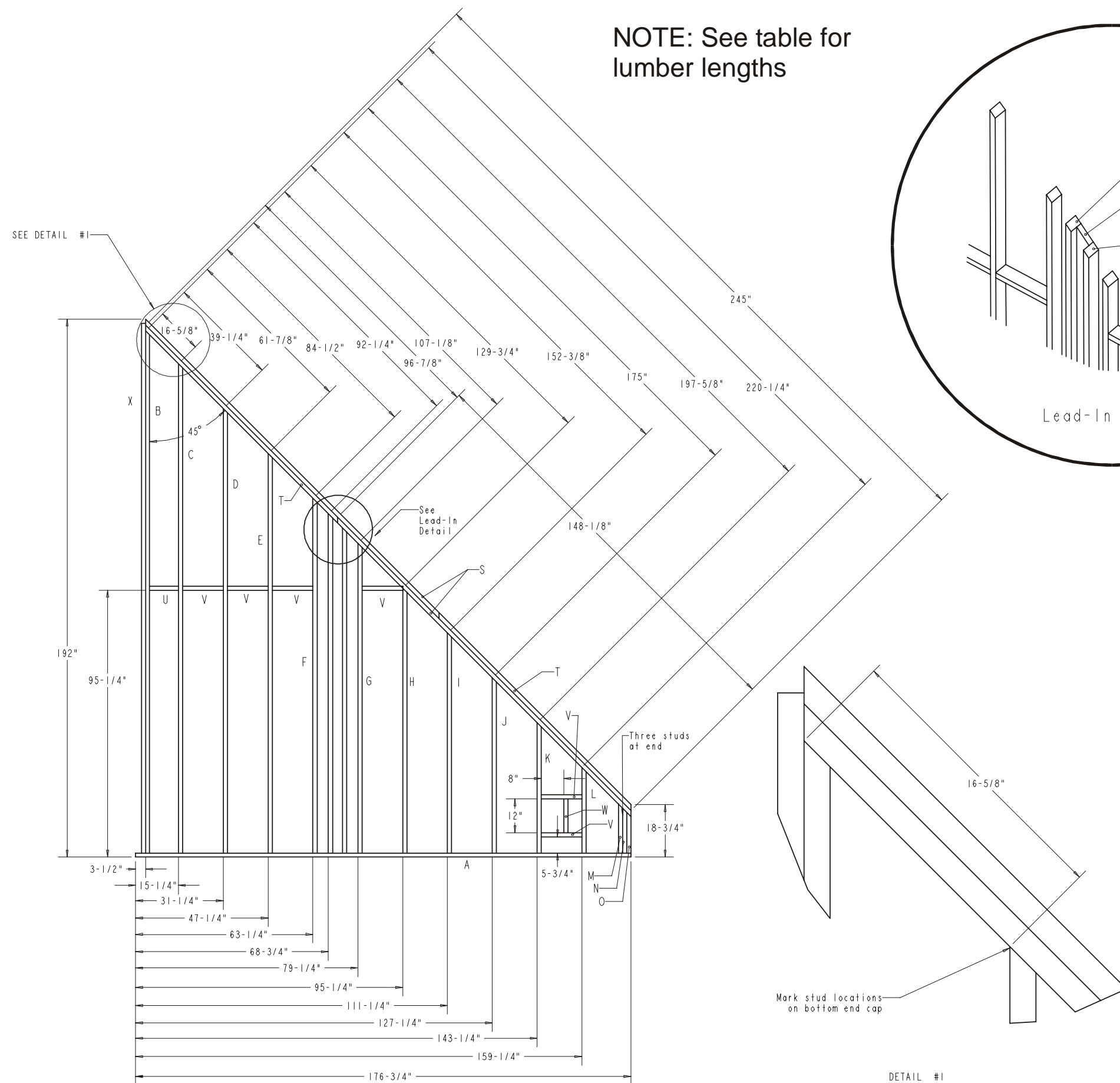

Item	Qty	Length	Material
X	1	189"	2x4x16'
W	1	12"	
V	7	14 1/2"	2x4x8'
U	1	10 1/4"	
T	2	98 3/8"	2x4x10' (2)
S	2	149 5/8"	2x4x14' (2)
R	1	116"	2x4x10'
Q	1	119 1/2"	2x4x10'
P	1	121"	2x4x12'
O	1	14 1/2"	
N	1	16"	2x4x8'
M	1	17 1/2"	
L	1	30 1/2"	2x4x8'
K	1	46 1/2"	
J	1	62 1/2"	2x4x8'
I	1	78 1/2"	2x4x8'
H	1	94 1/2"	2x4x8'
G	1	110 1/2"	2x4x10'
F	1	126 1/2"	2x4x12'
E	1	142 1/2"	2x4x12'
D	1	158 1/2"	2x4x14'
C	1	174 1/2"	2x4x16'
B	1	186 1/4"	2x4x16'
A	1	176 3/4"	2x4x16' Treated

DETAIL #1
SCALE 0.250

NOTE: See table for
lumber lengths

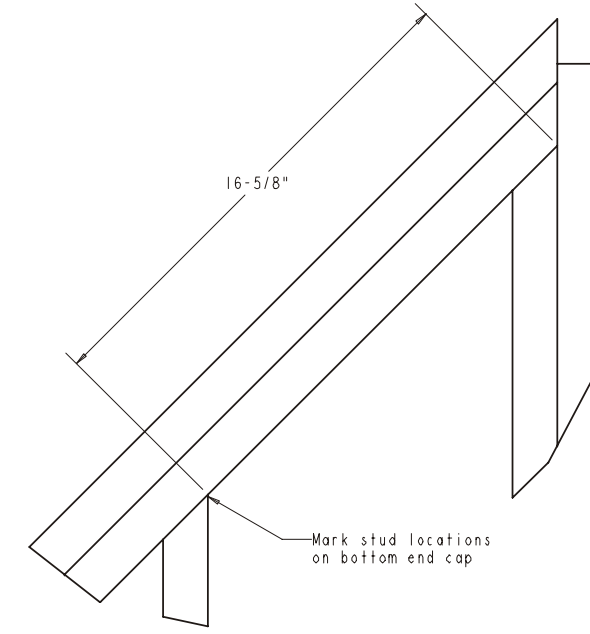
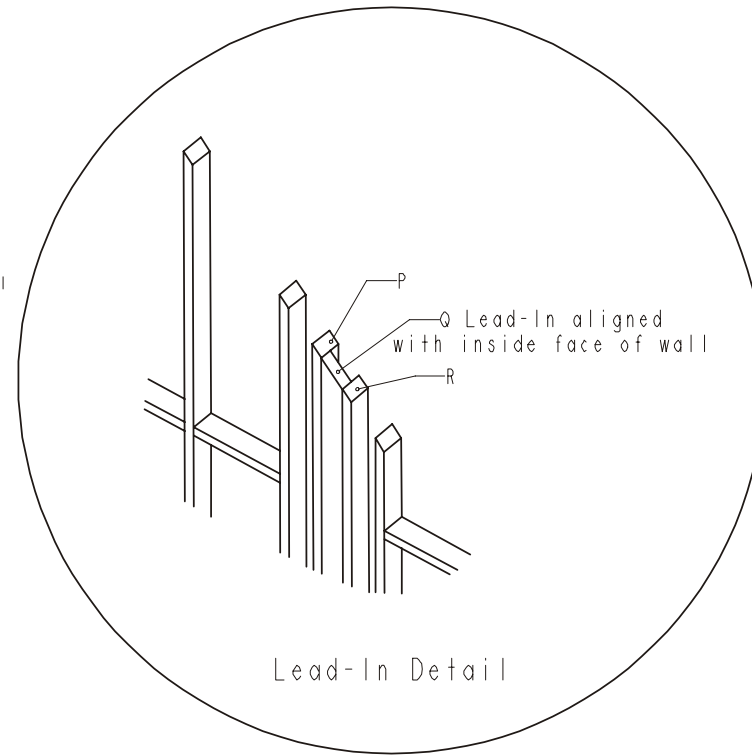
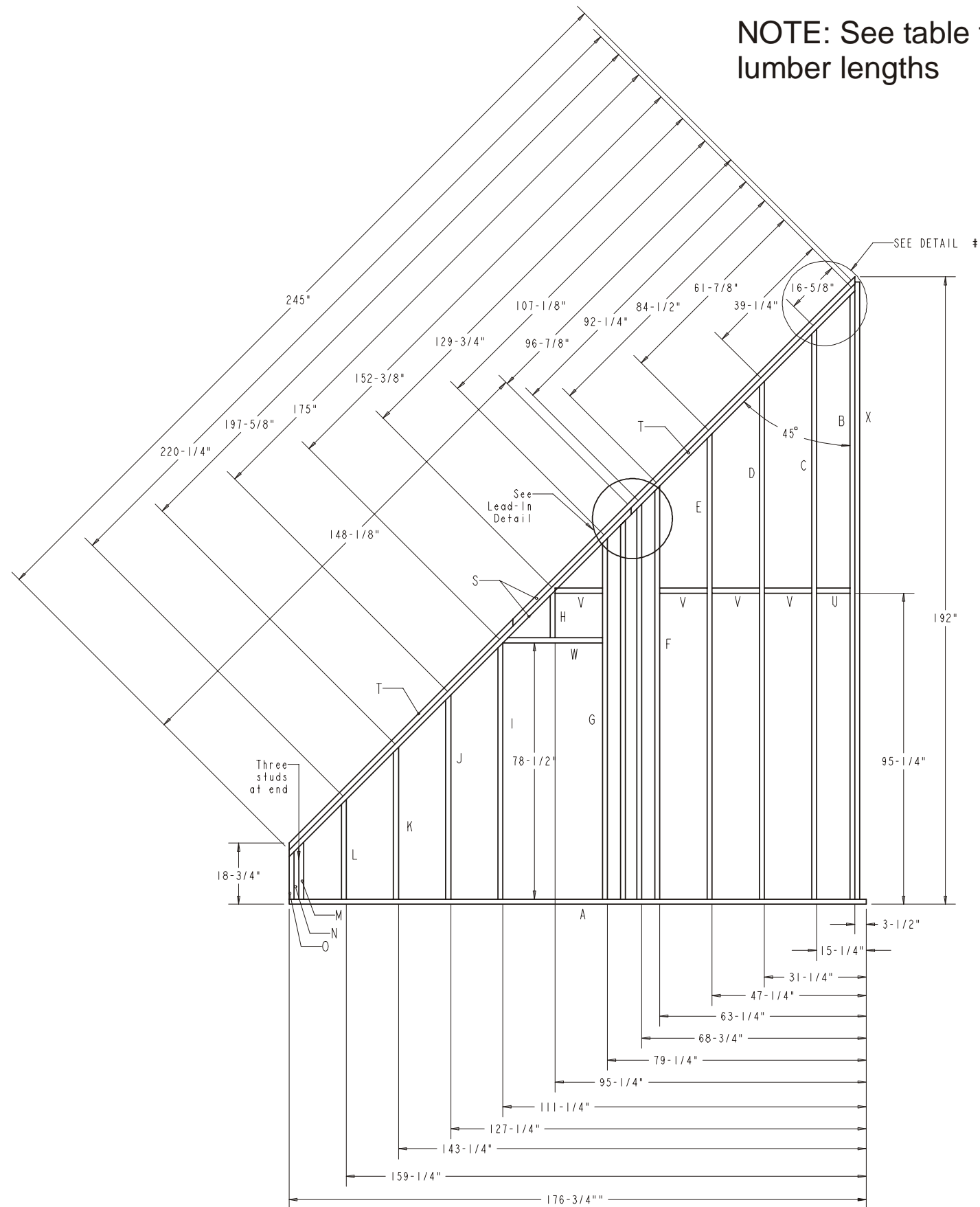

DETAIL #1
SCALE 0.250

Item	Qty	Length	Material
X	1	189"	2x4x16'
W	1	30 1/2"	2x4x8'
V	4	14 1/2"	
U	1	10 1/4"	2x4x8'
T	2	98 3/8"	
S	2	149 5/8"	2x4x14' (2)
R	1	116"	2x4x10'
Q	1	119 1/2"	2x4x10'
P	1	121"	2x4x12'
O	1	14 1/2"	2x4x8'
N	1	16"	
M	1	17 1/2"	2x4x8'
L	1	30 1/2"	
K	1	46 1/2"	2x4x8'
J	1	62 1/2"	
I	1	78 1/2"	2x4x8'
H	1	14 1/2"	
G	1	110 1/2"	2x4x10'
F	1	126 1/2"	2x4x12'
E	1	142 1/2"	2x4x12'
D	1	158 1/2"	2x4x14'
C	1	174 1/2"	2x4x16'
B	1	186 1/4"	2x4x16'
A	1	176 3/4"	2x4x16' Treated

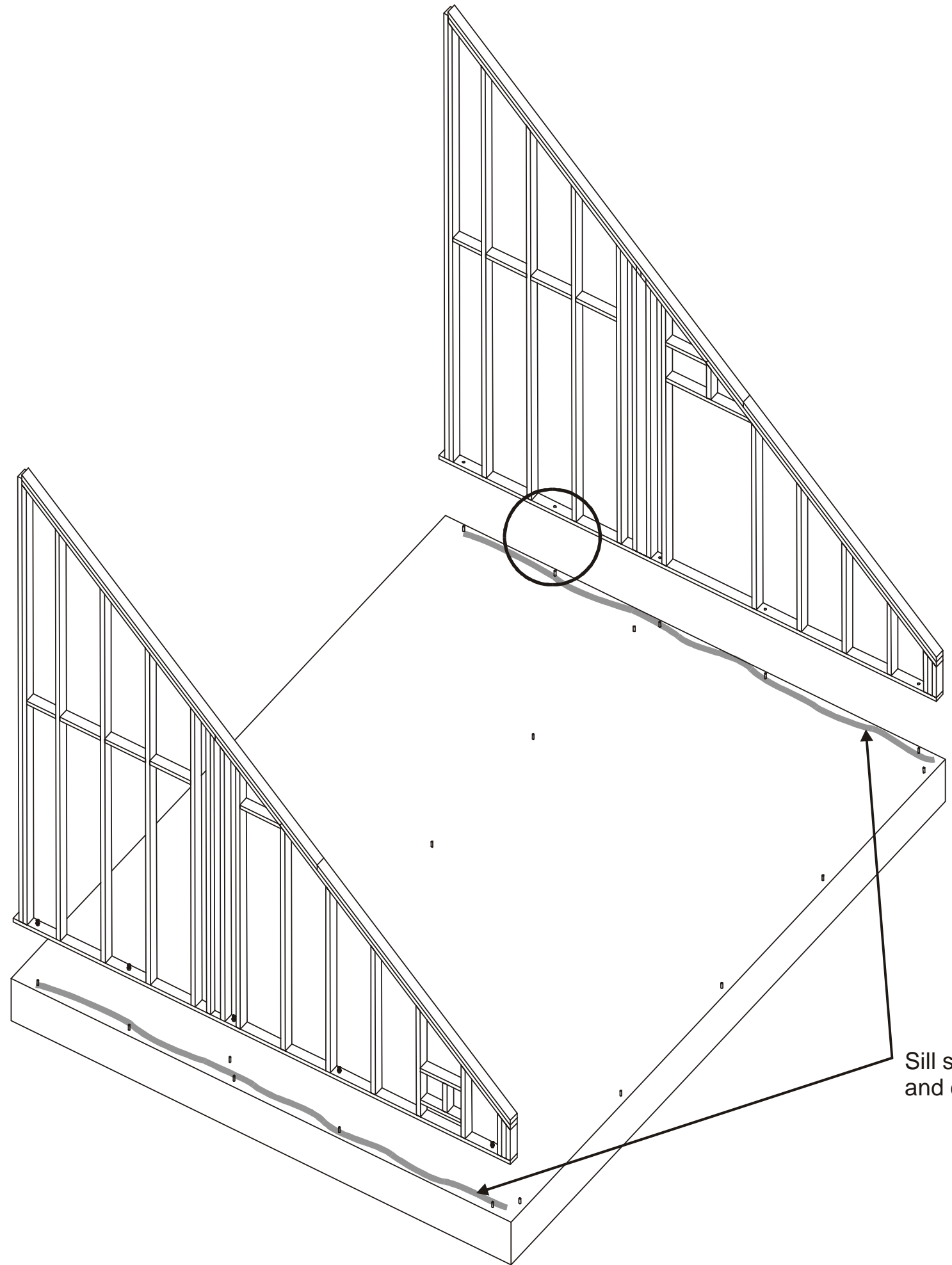

Sill seal between slab and end wall sill plates

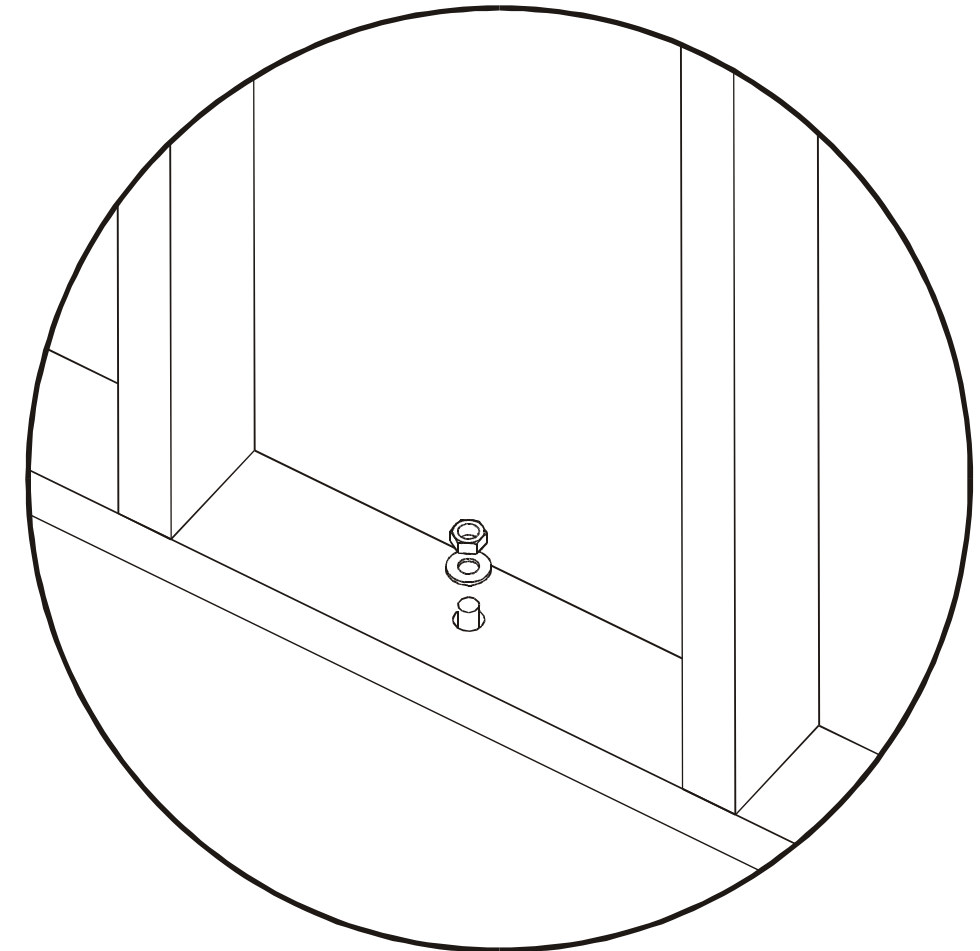

NOTE: See table for
lumber lengths

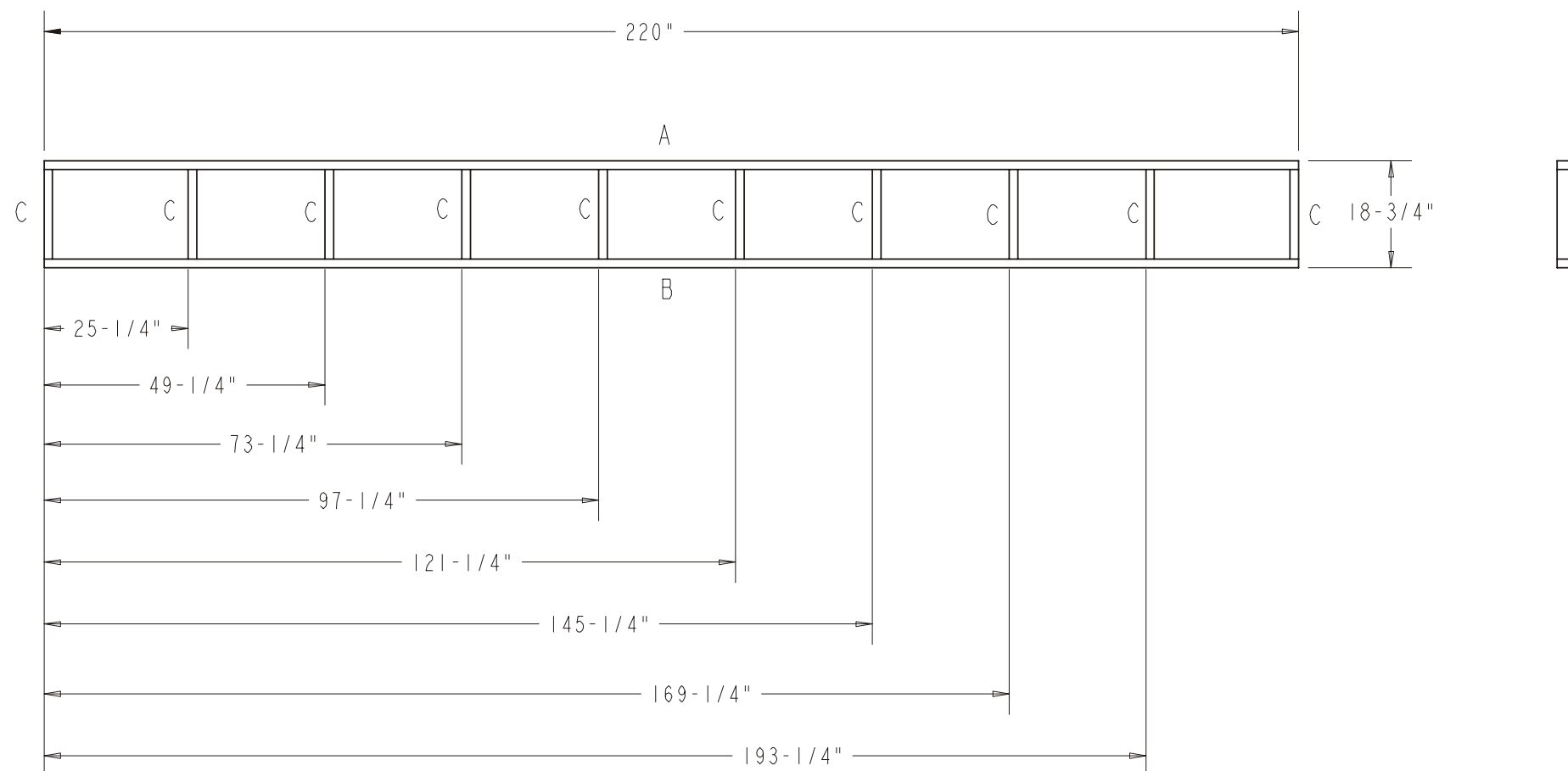

Item	Qty	Length	Material
C	10	15 3/4"	2x4x8 (2)
B	1	220"	2x4x10' Treated (2)
A	1	220"	2x6x20'

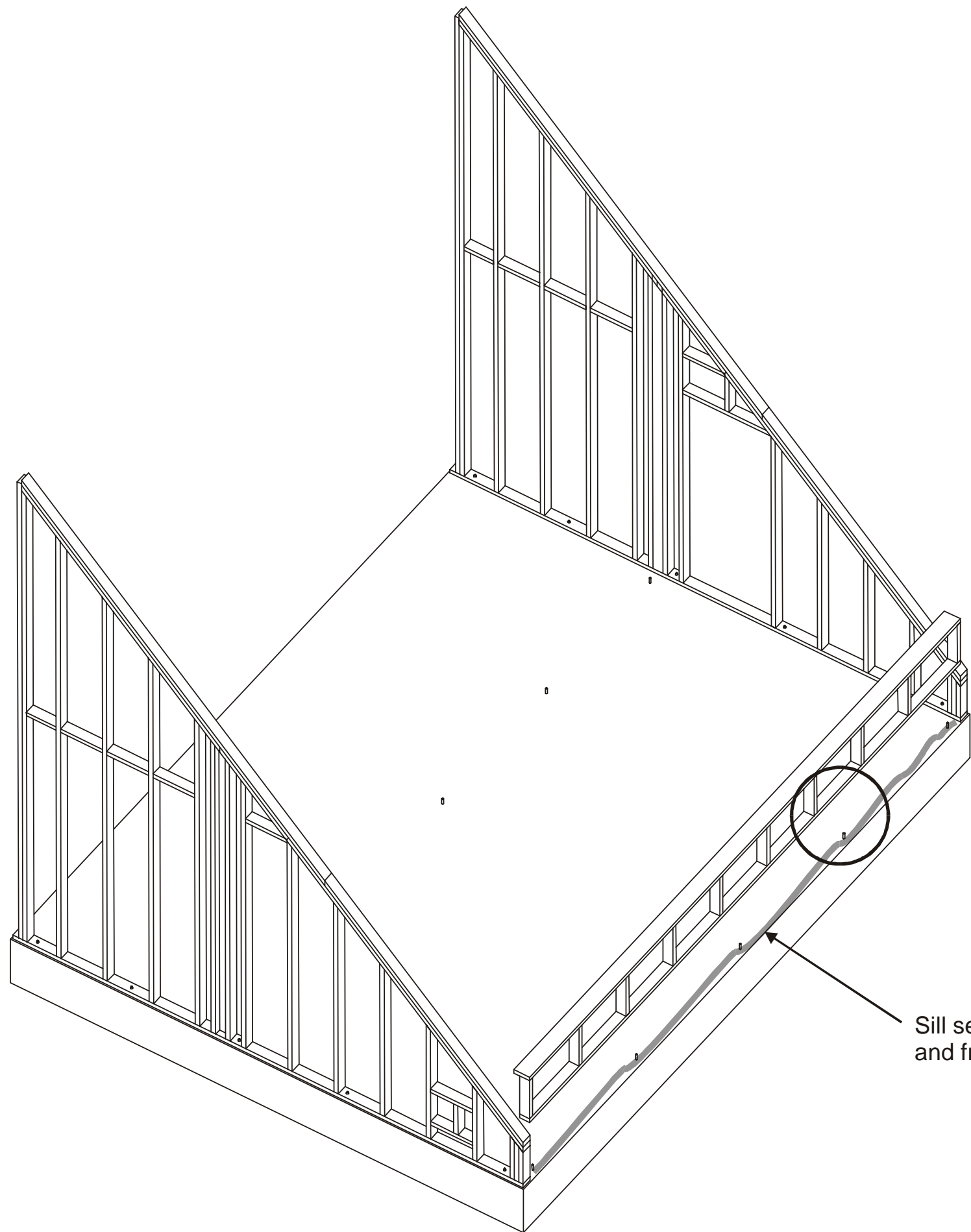

Sill seal between slab
and front wall sill plate

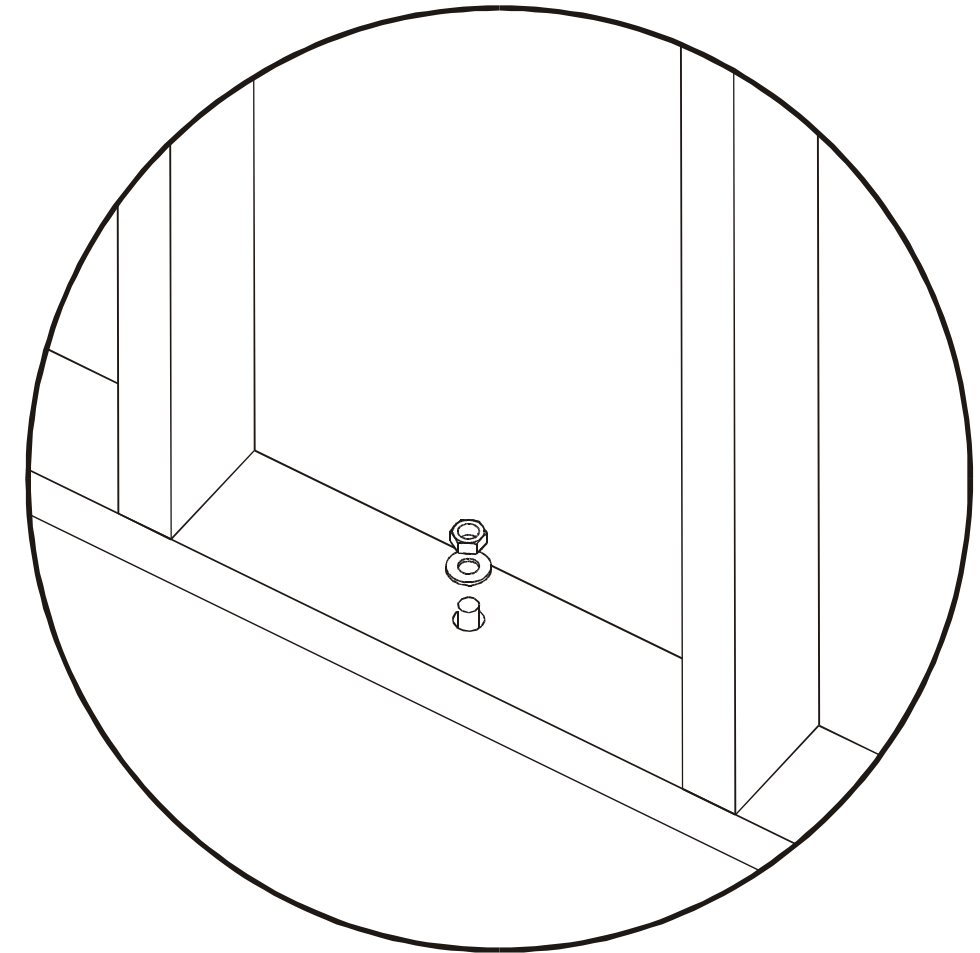

NOTE: See table for
lumber lengths

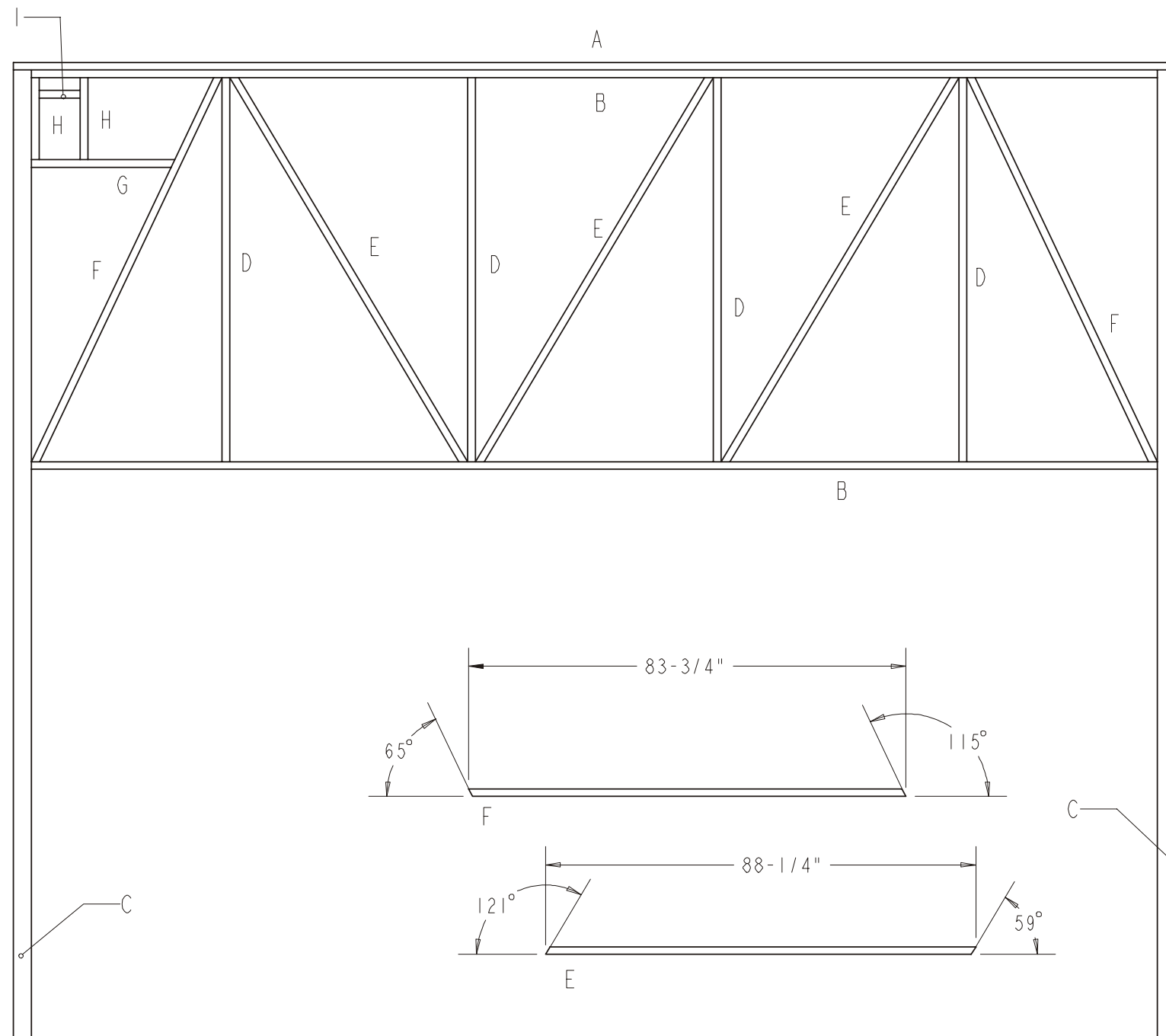

See Detail

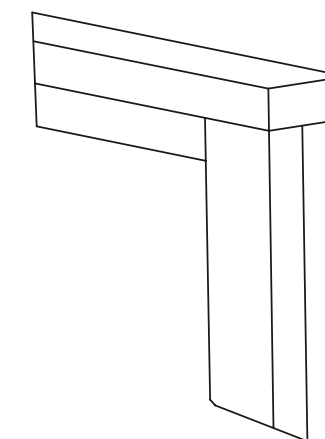
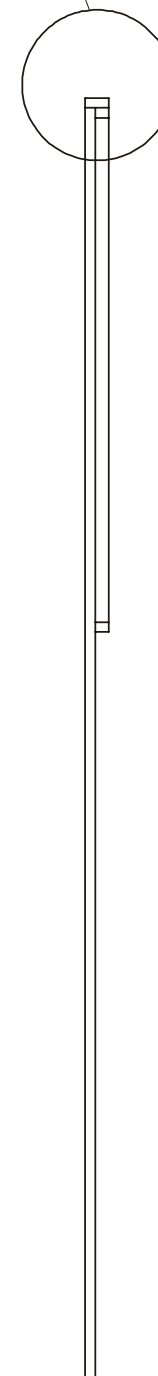

SCALE 0.150

Item	Qty	Length	Material
I	1	8"	
H	2	16"	
G	1	28"	2x4x8'
F	2	83 3/4"	2x4x8' (2)
E	3	88 1/4"	2x4x8' (3)
D	4	75"	2x4x8' (4)
C	2	189"	2x4x16' (2)
B	2	220"	2x4x20' (2)
A	1	227"	2x4x20'

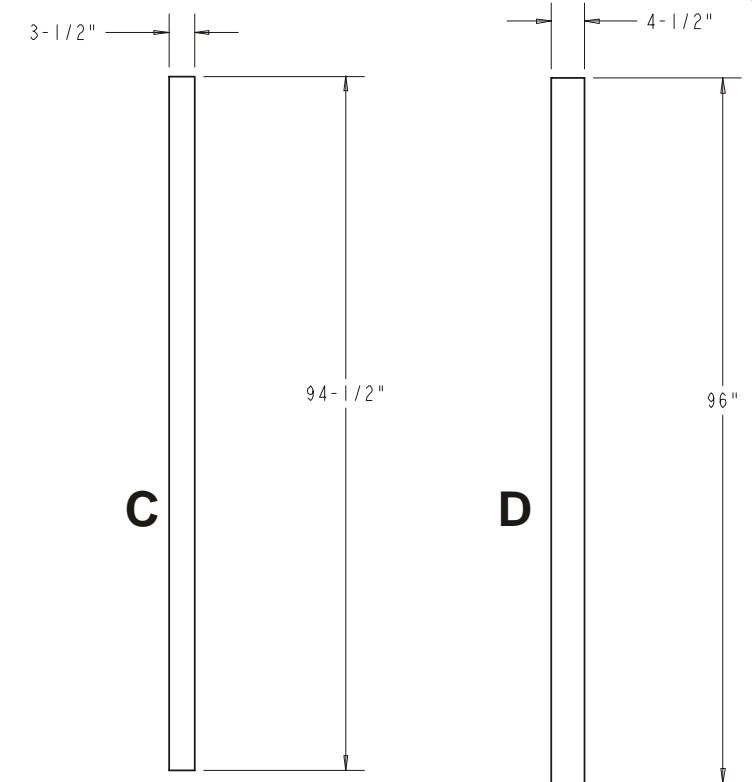
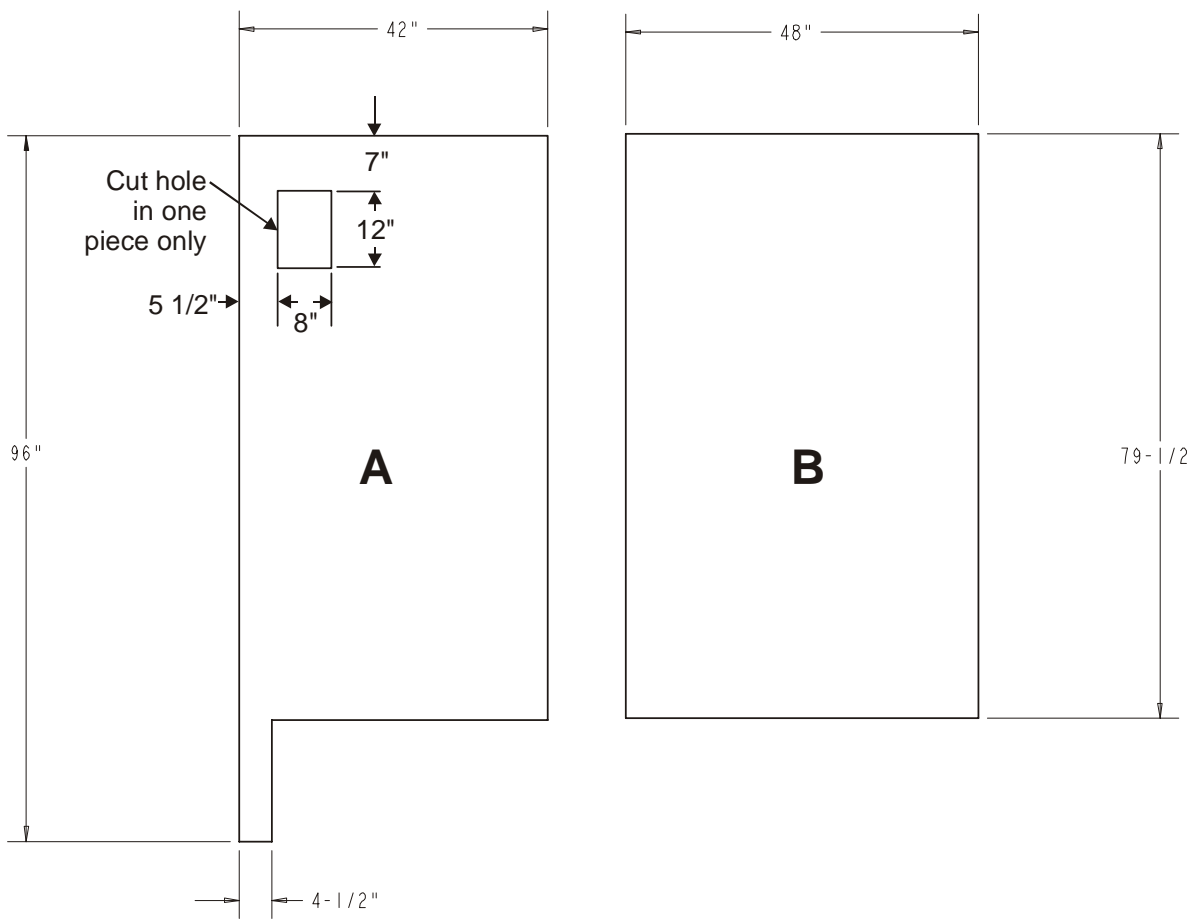
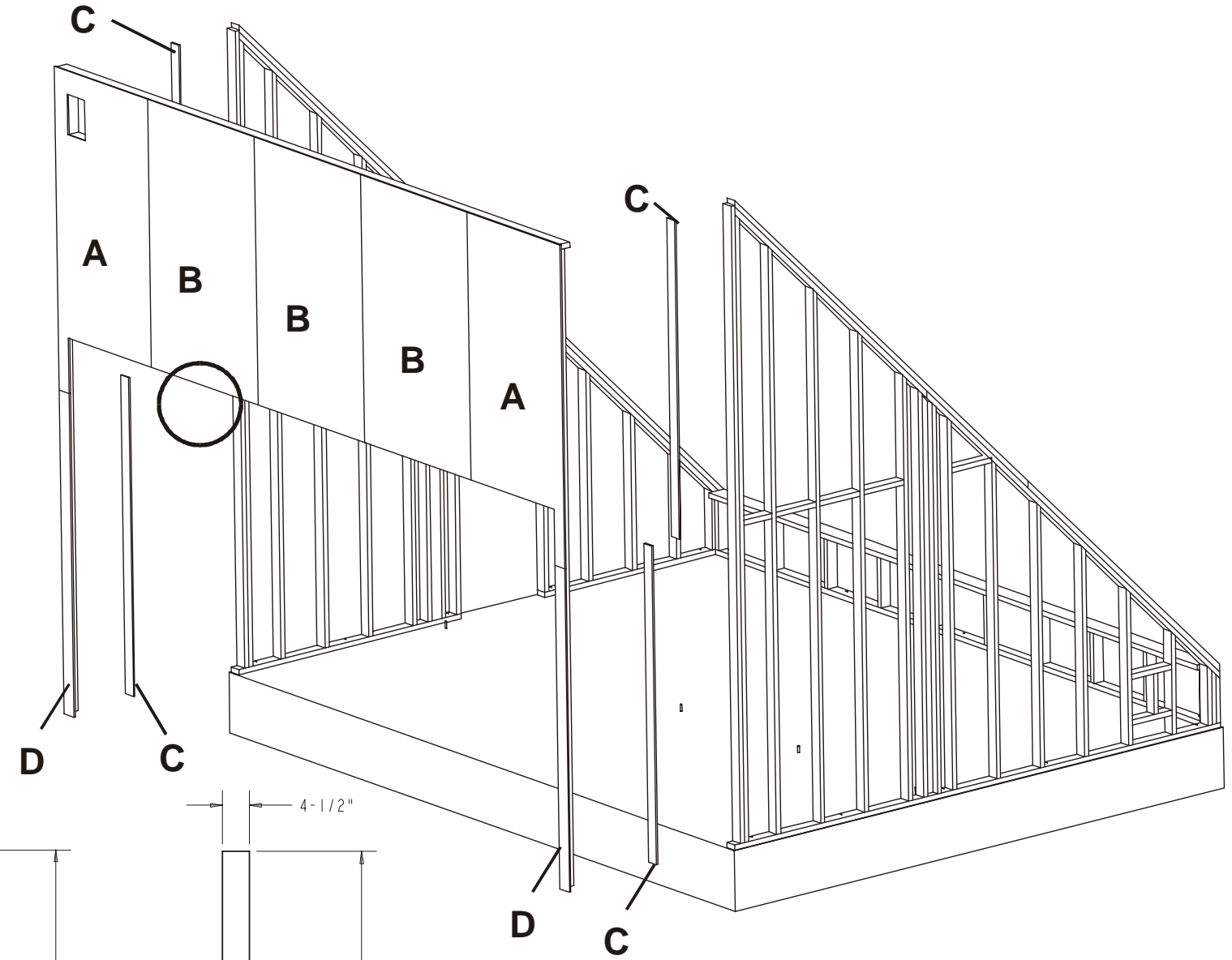
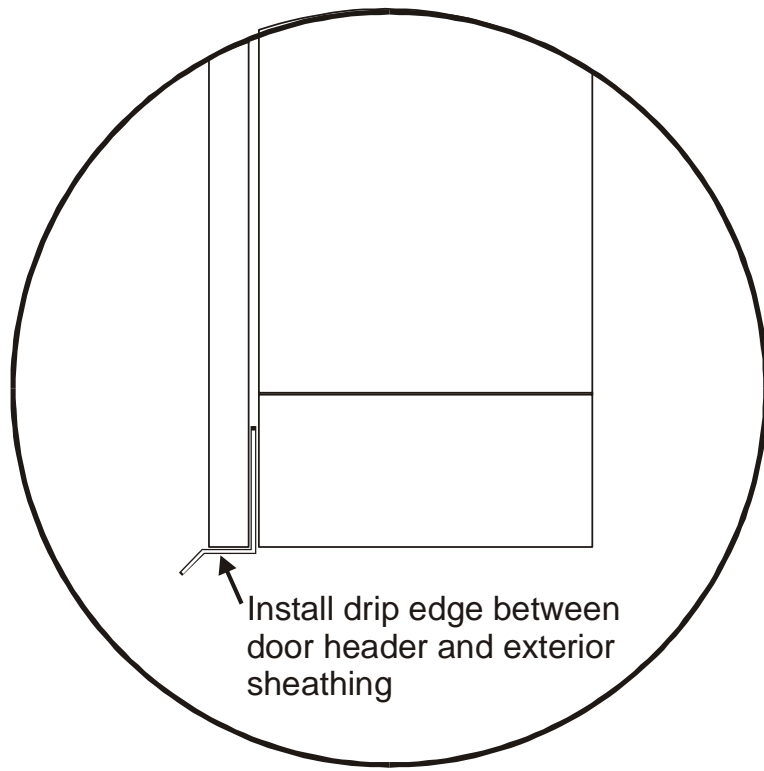

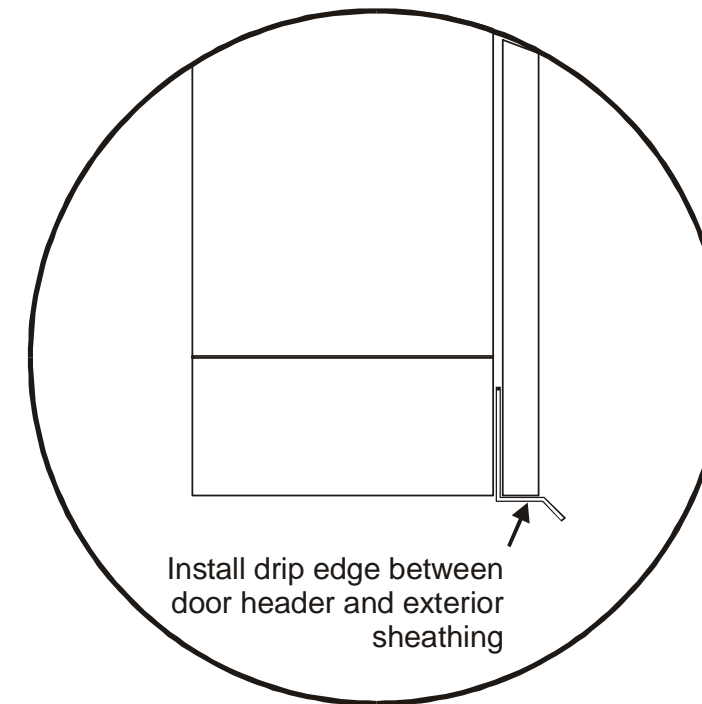
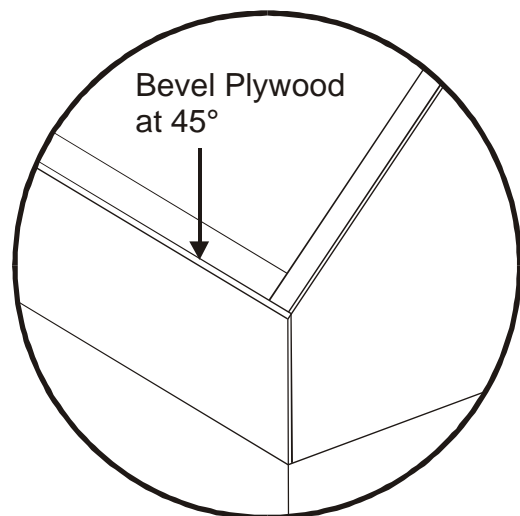
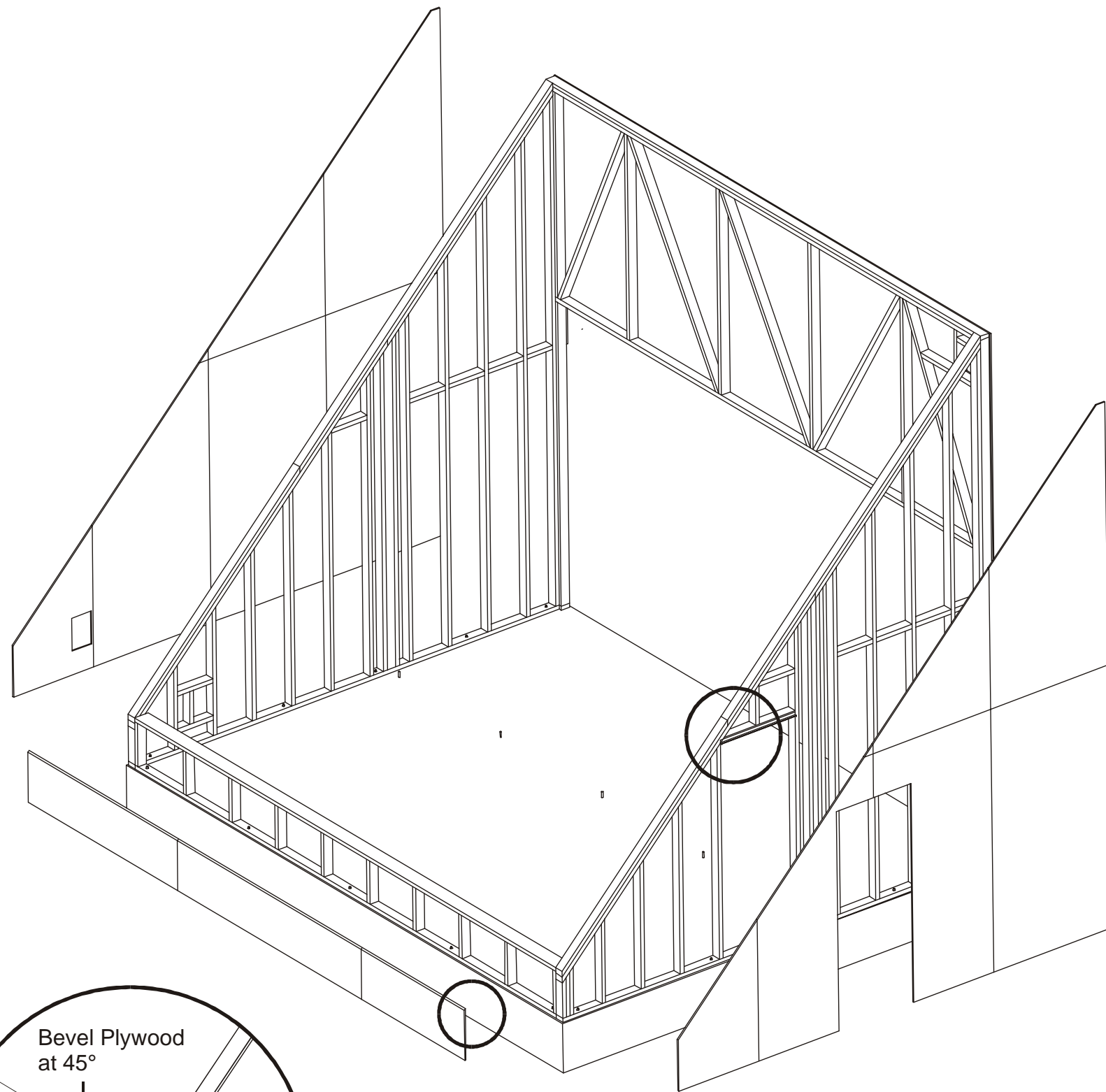

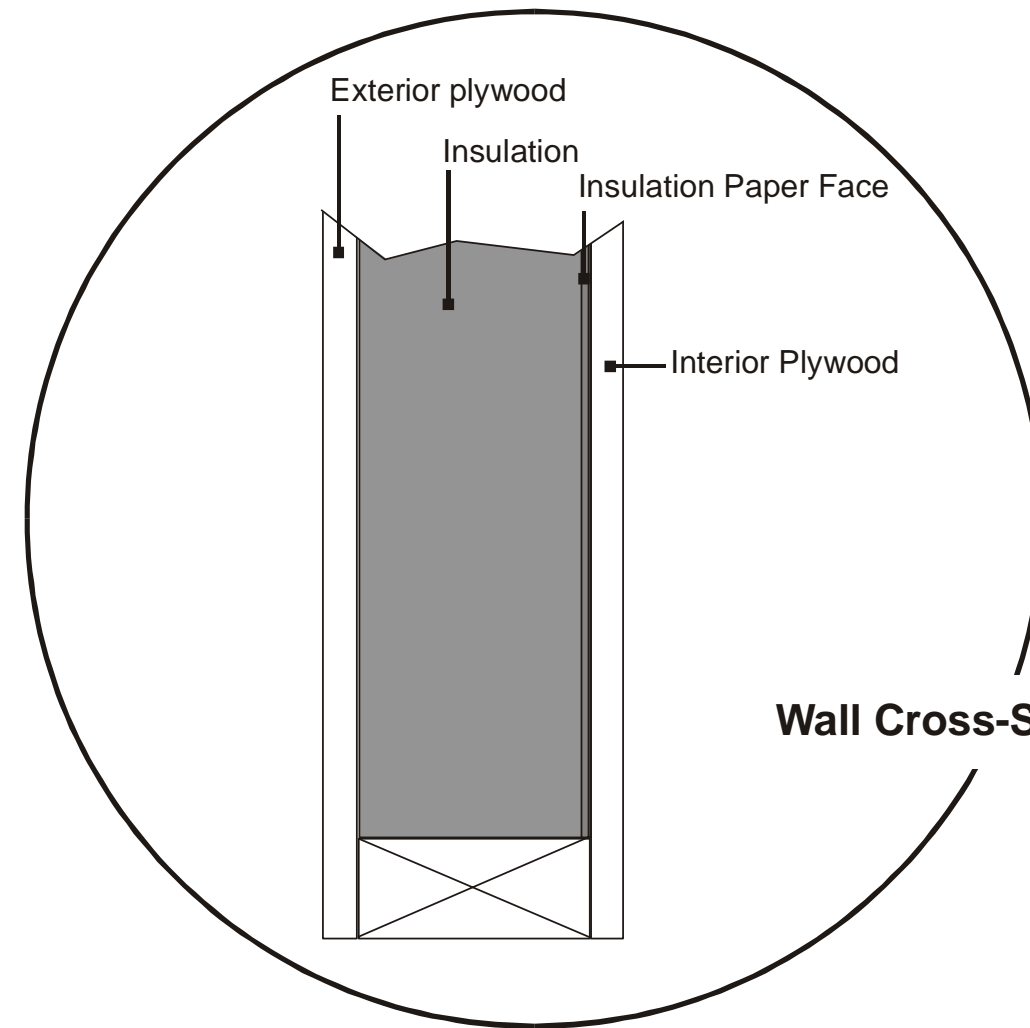
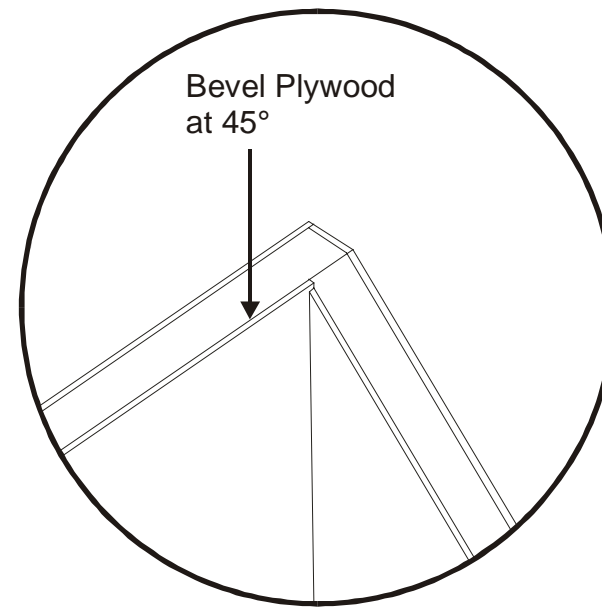
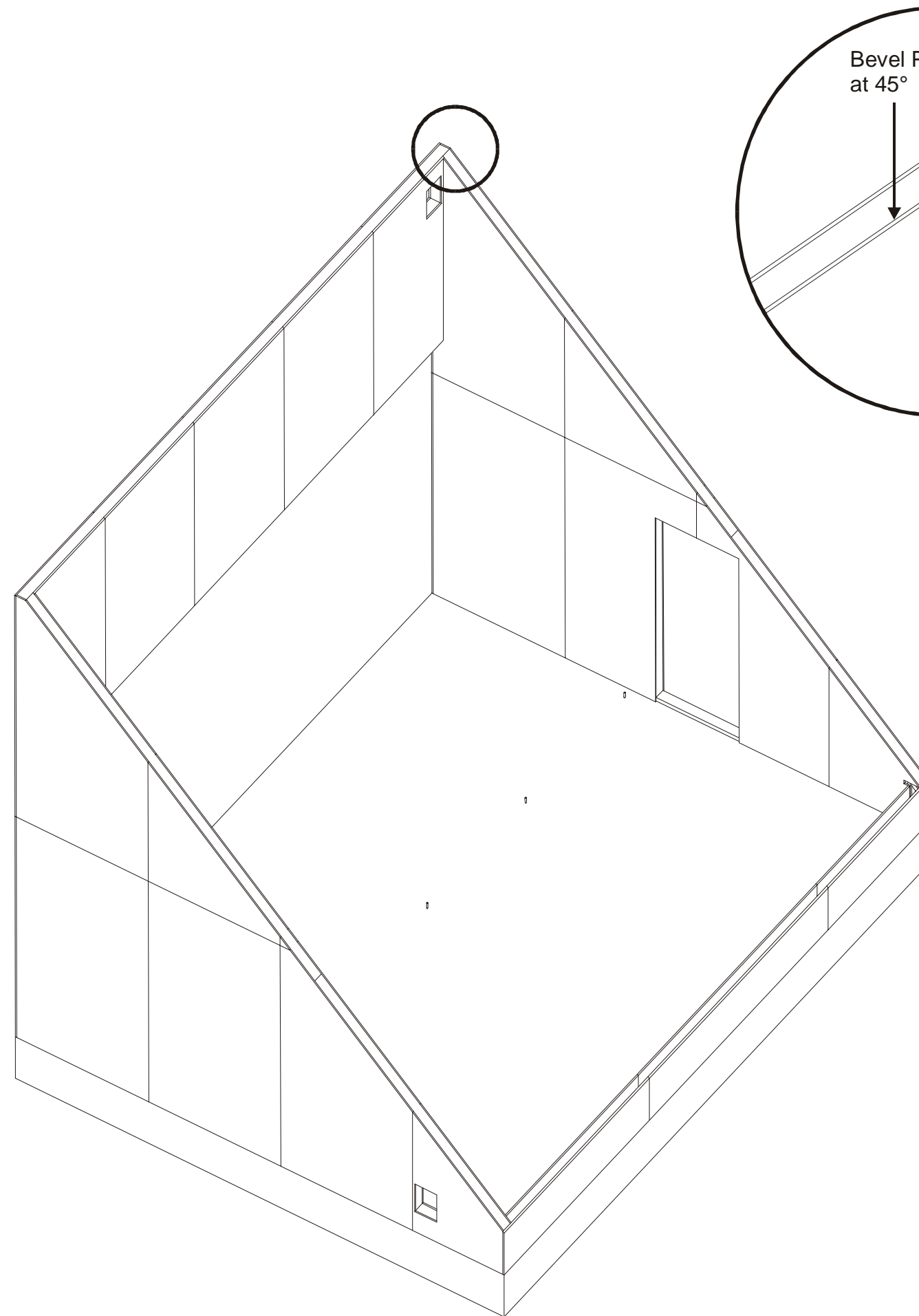

Wall Cross-Section

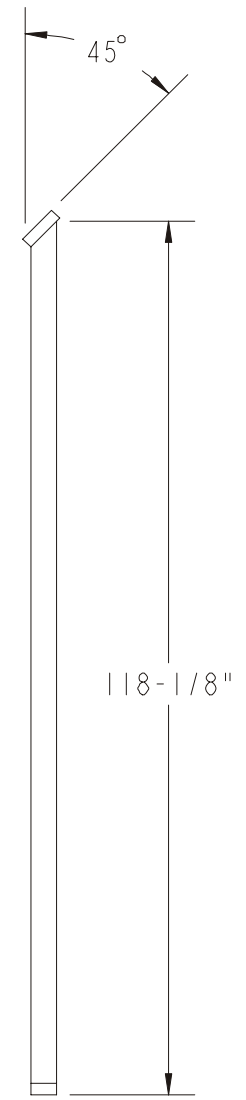
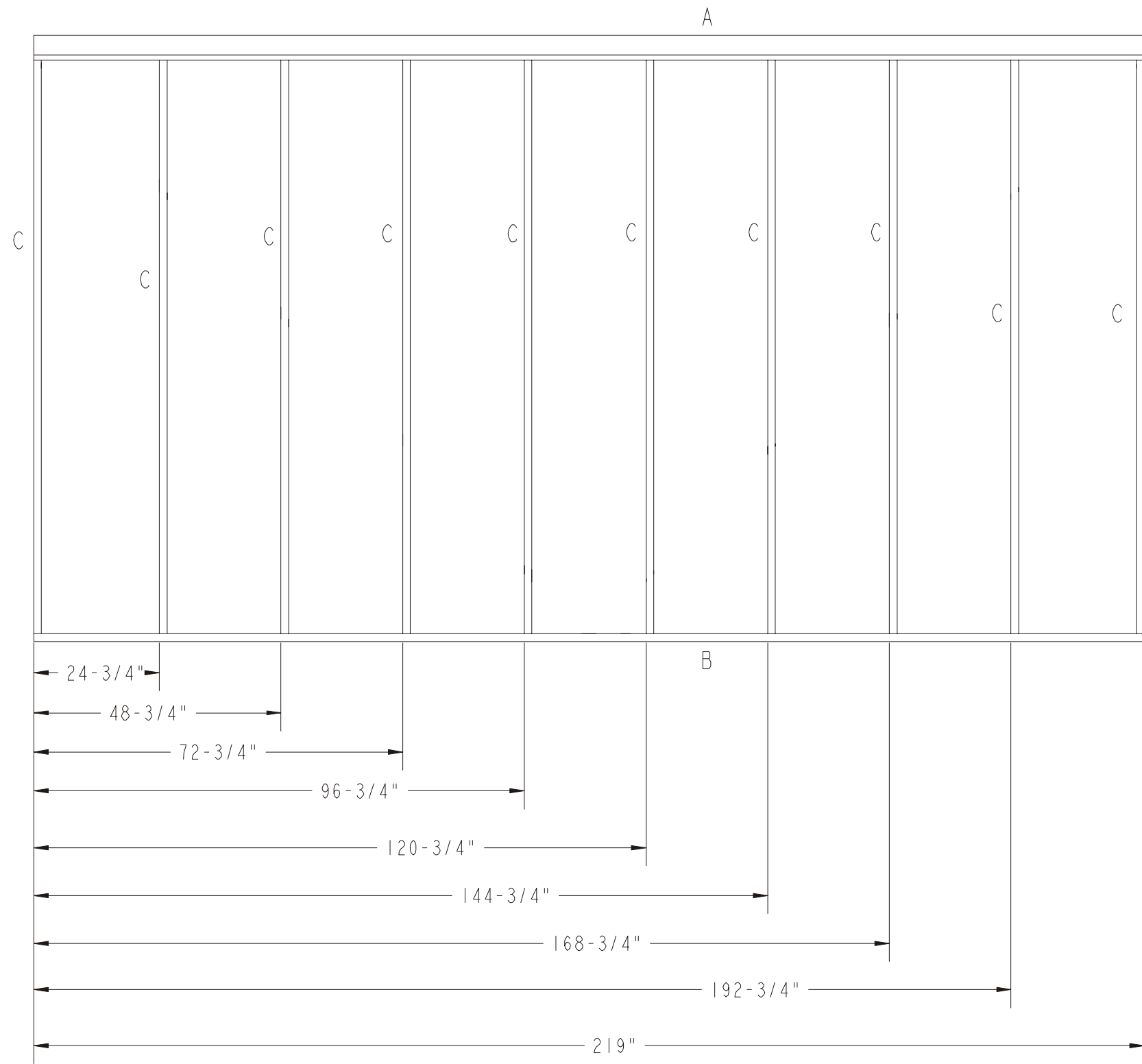

NOTE: See table for lumber lengths

Item	Qty	Length	Material
C	10	116 5/8"	2x4x10' (10)
B	2	109 1/2"	2x4x10' Treated (2)
A	1	219"	2x6x20'

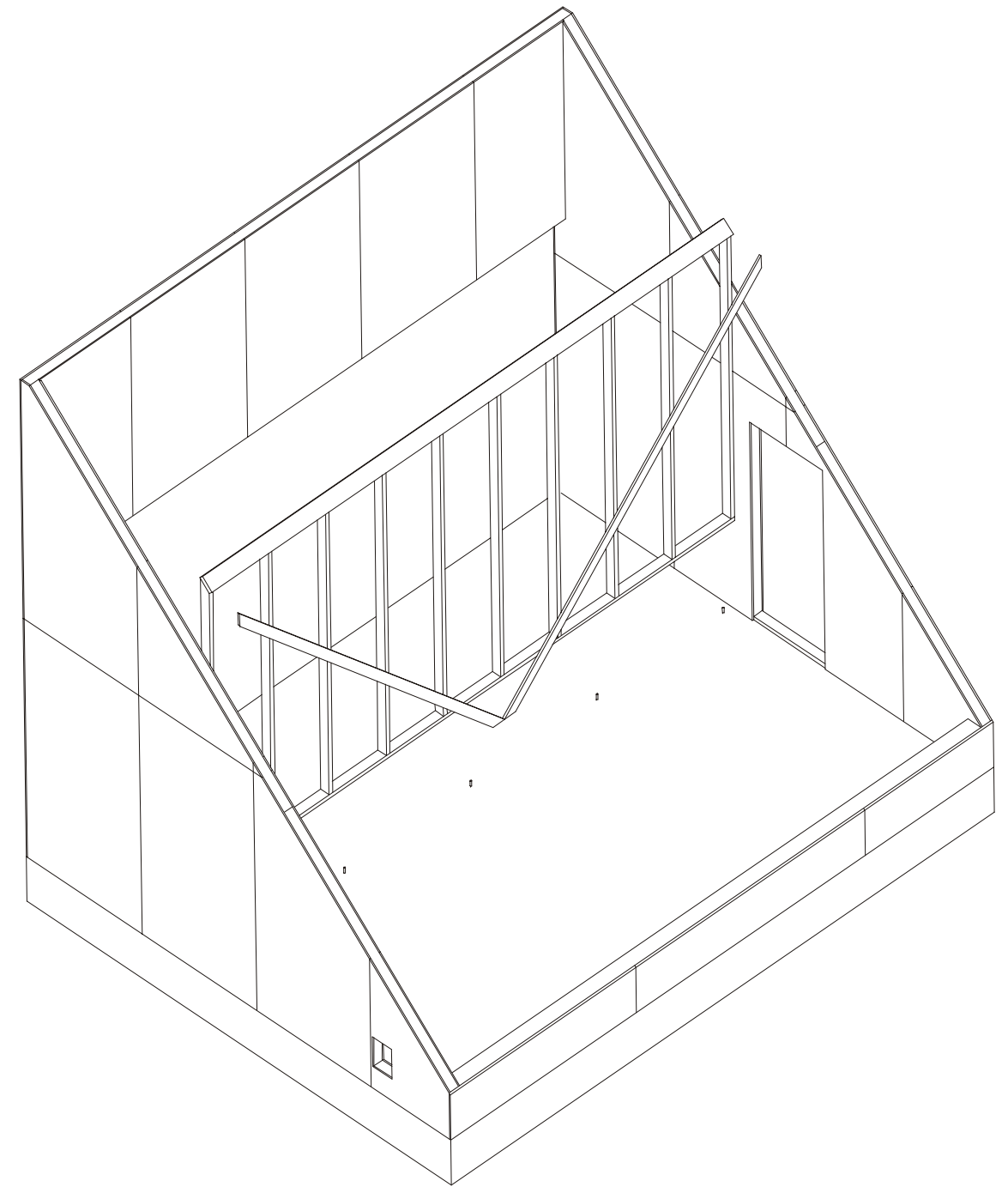
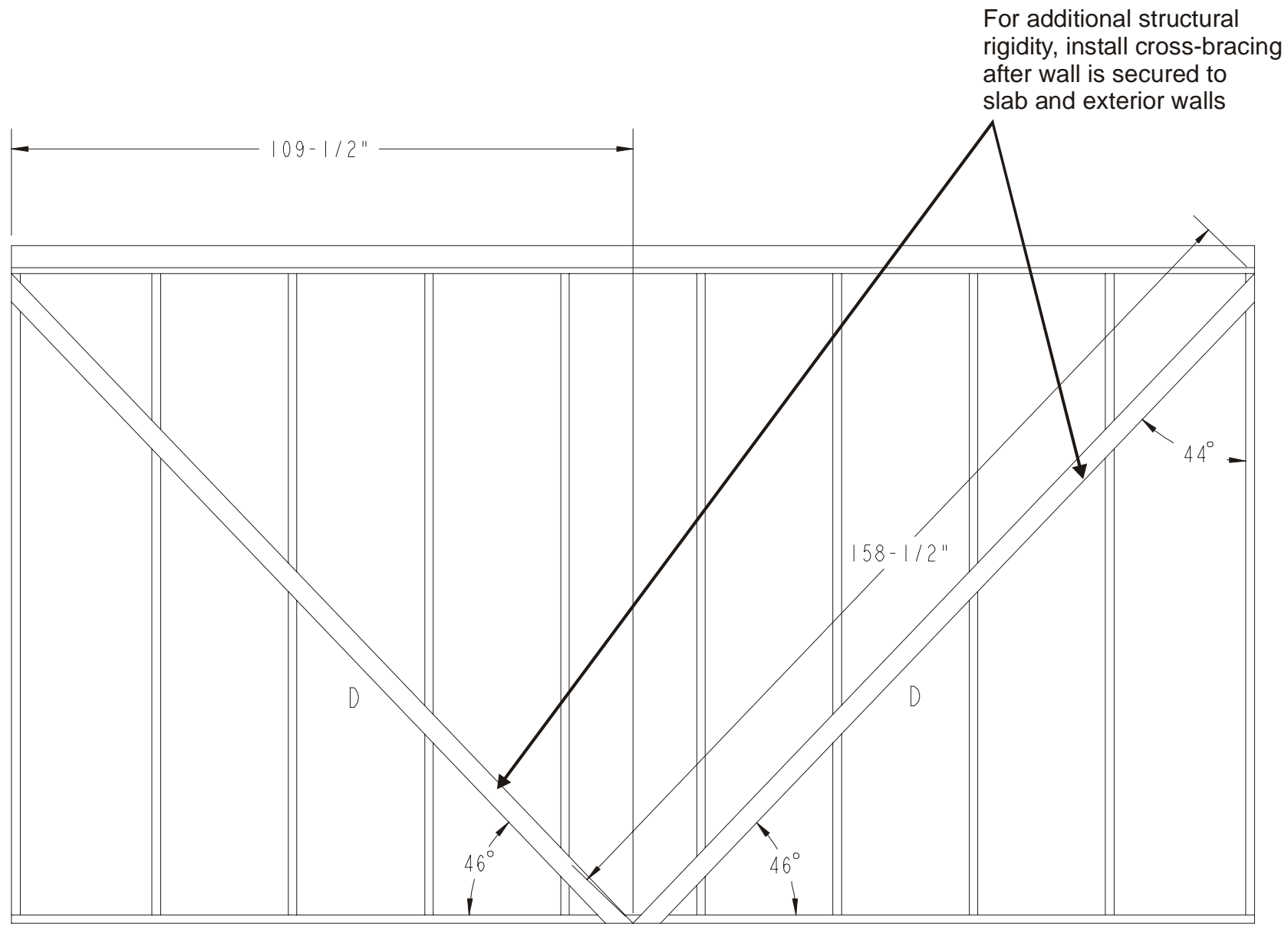

Item	Qty	Length	Material
D	2	158 1/2"	1x4x14' (2)

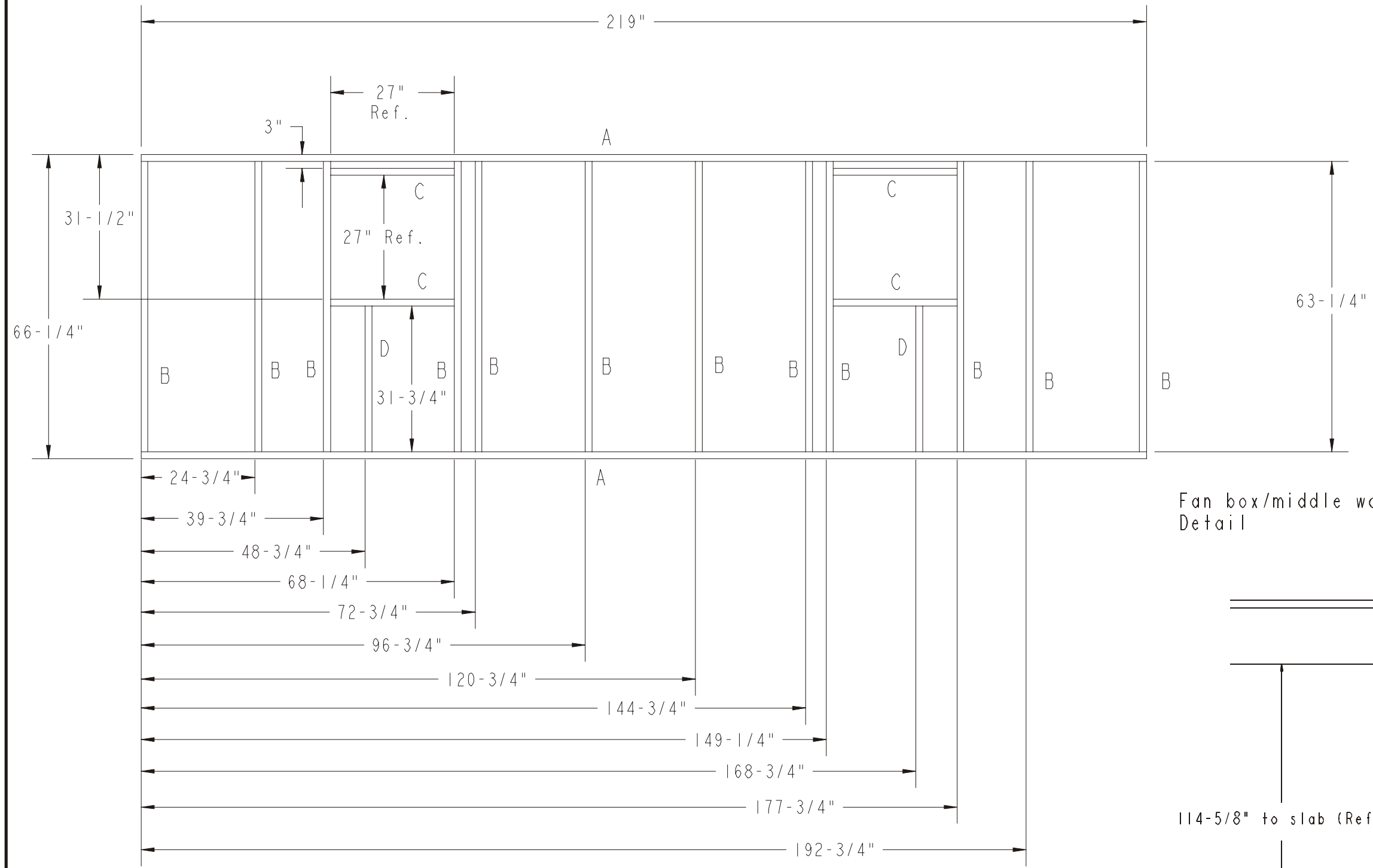

Fan box/middle wall
Detail

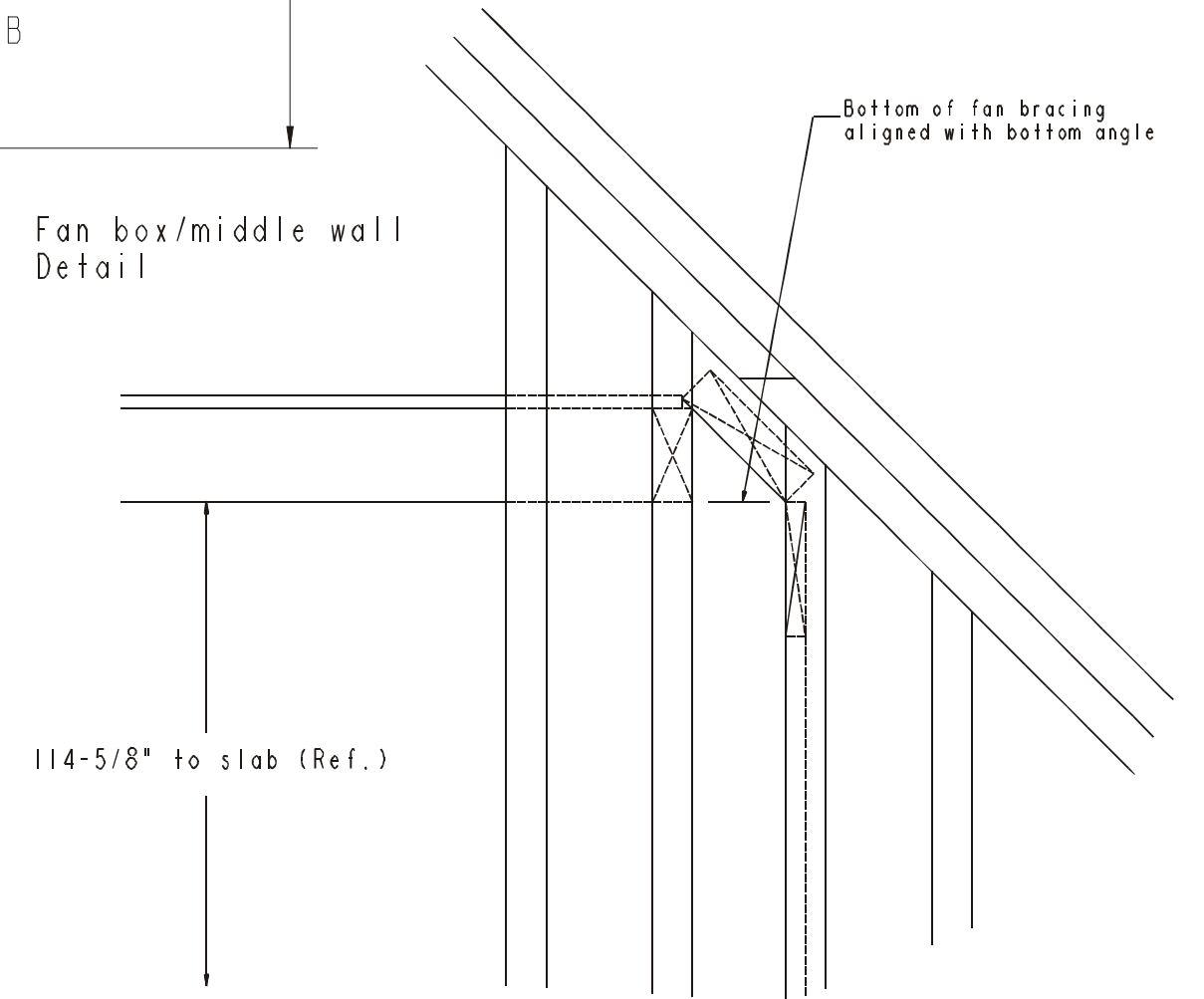

NOTE: See table for
lumber lengths

Item	Qty	Length	Material
D	2	31 3/4"	
C	4	27"	
B	12	63 1/4"	2x4x8' (12)
A	4	109 1/2"	2x4x10' (4)

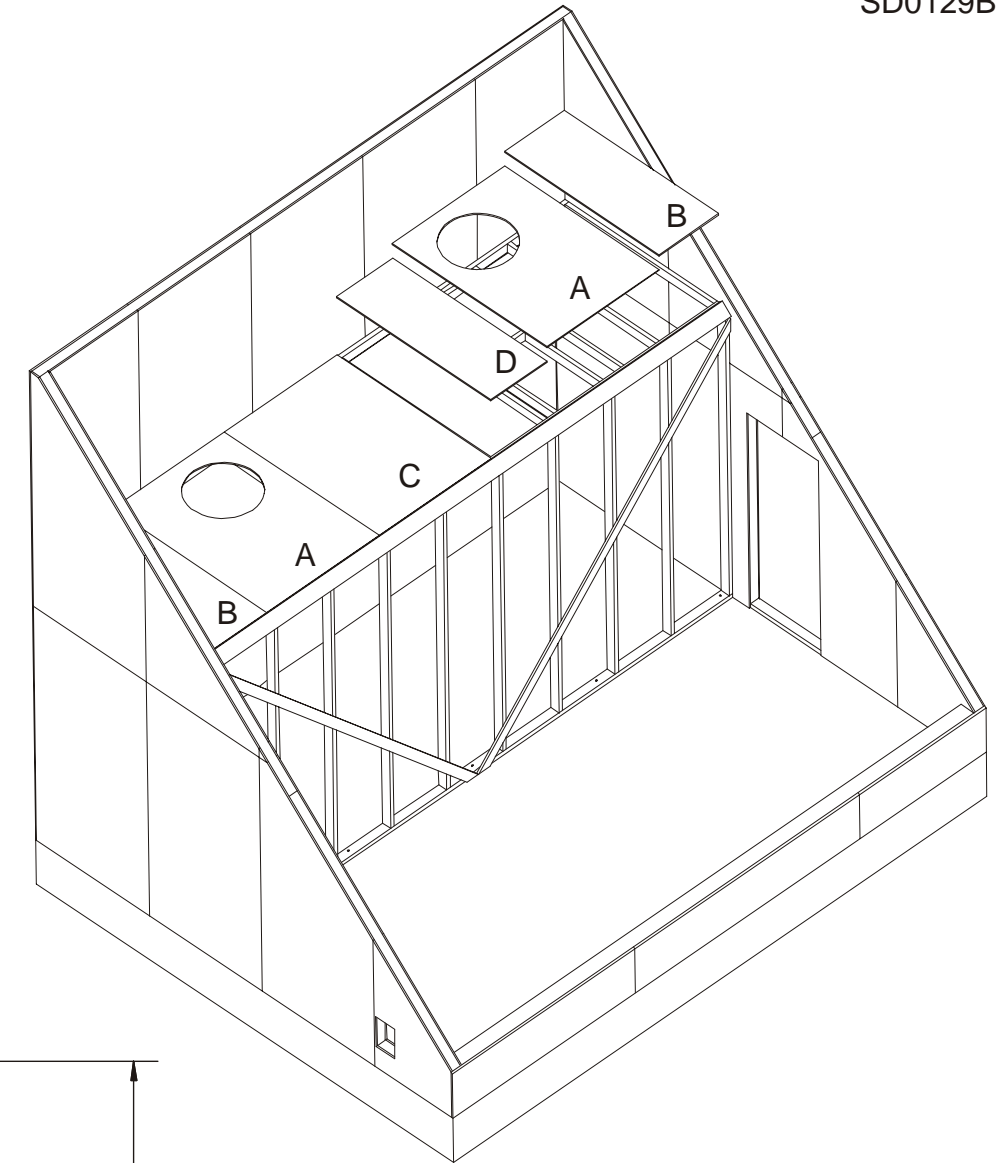
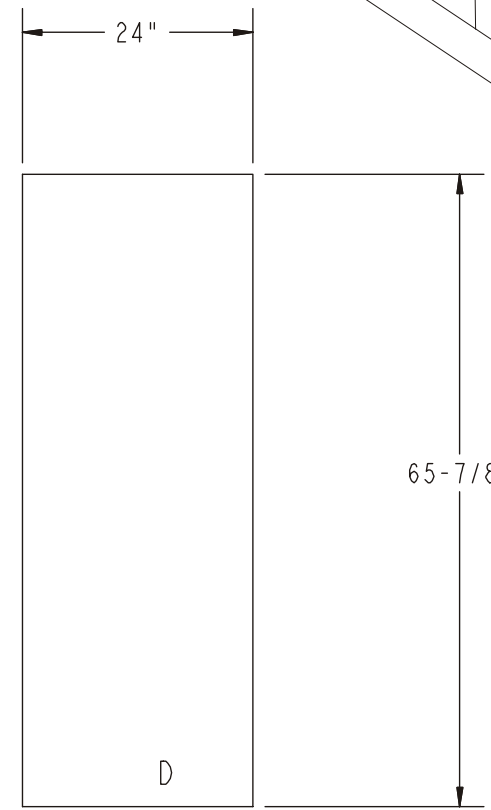
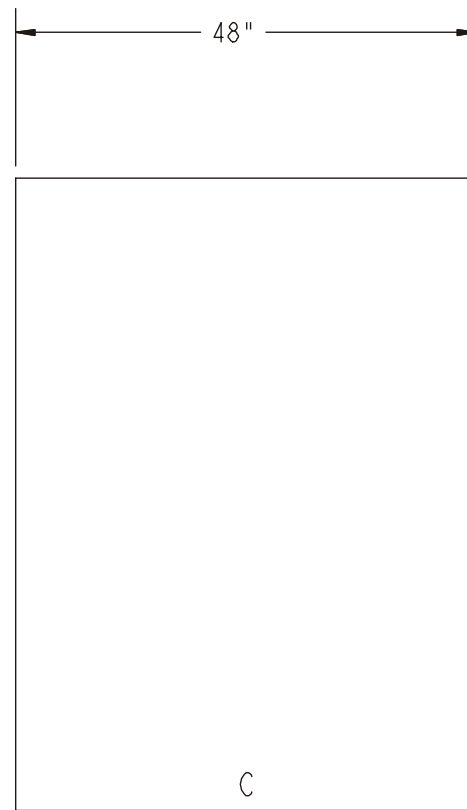
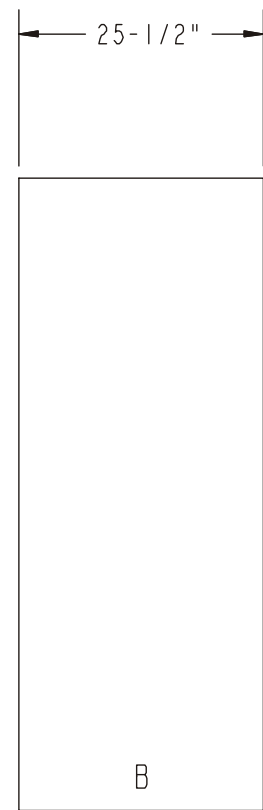
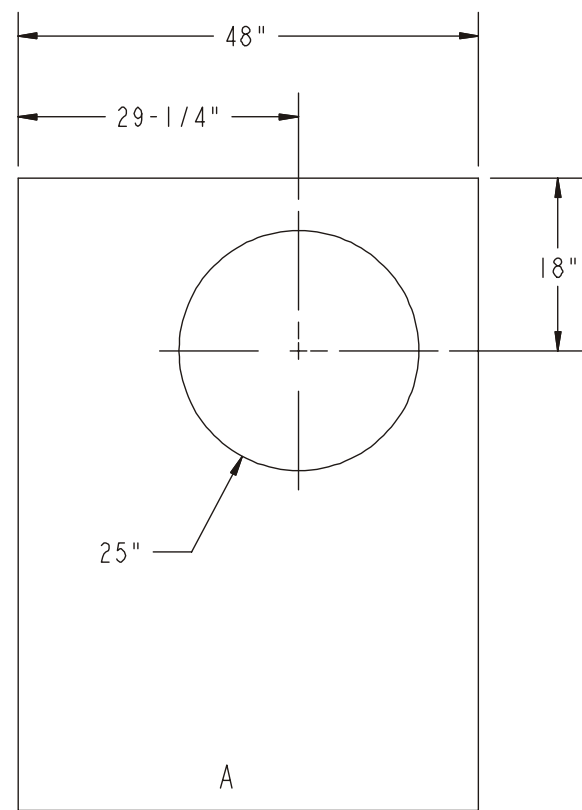

Item	Qty	65 7/8" x	Material
D	1	24"	4'x8'x1/2" BCX Plywood
C	1	48"	4'x8'x1/2" BCX Plywood
B	2	25 1/2"	4'x8'x1/2" BCX Plywood
A	2	48"	4'x8'x1/2" BCX Plywood

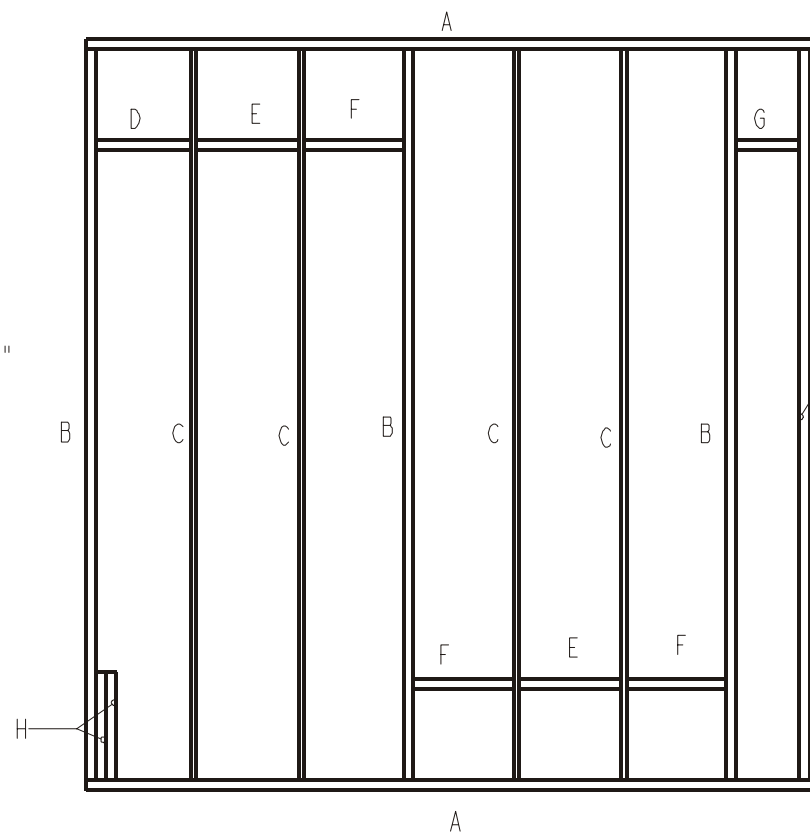
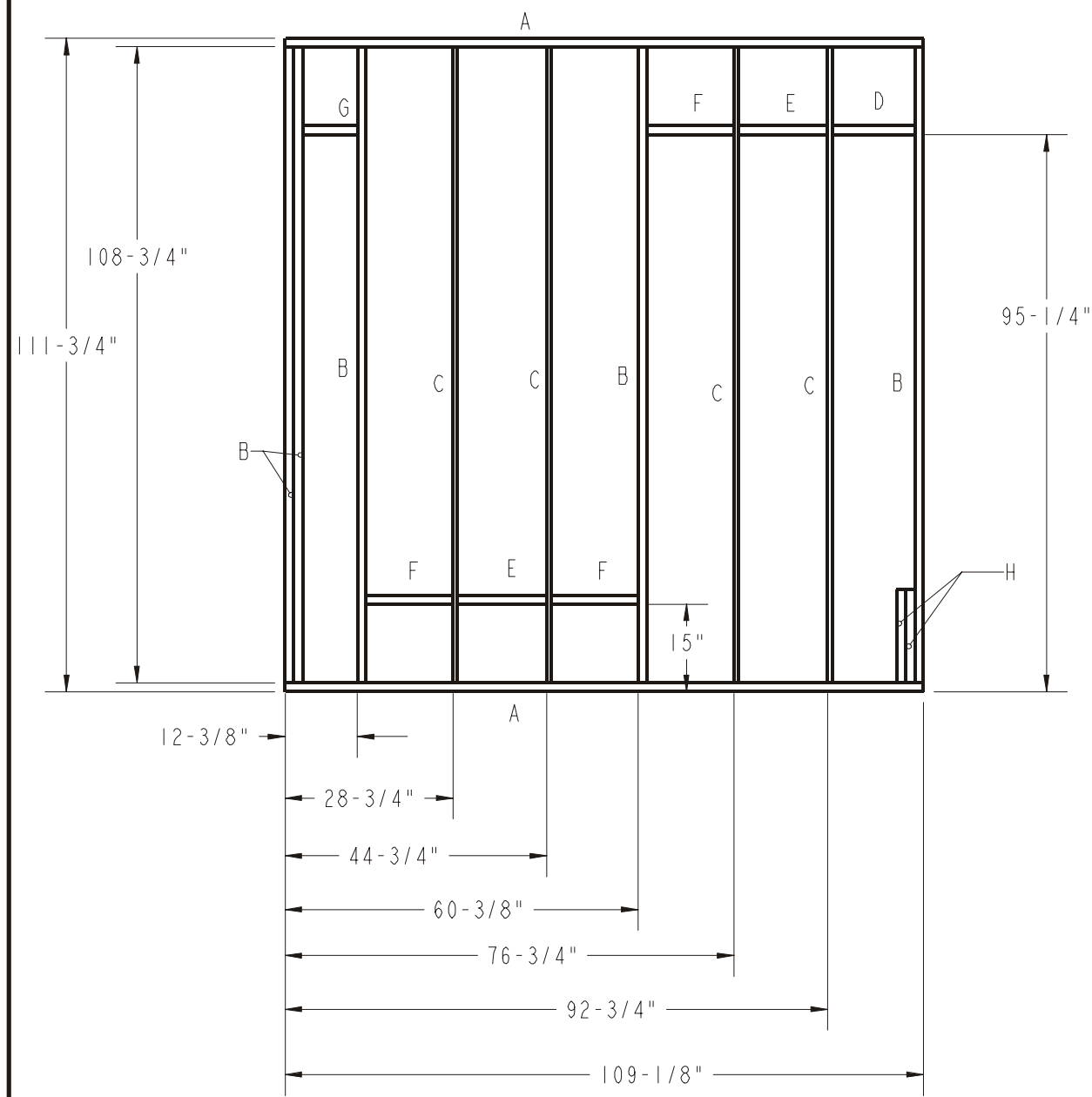

← Mark side with double studs

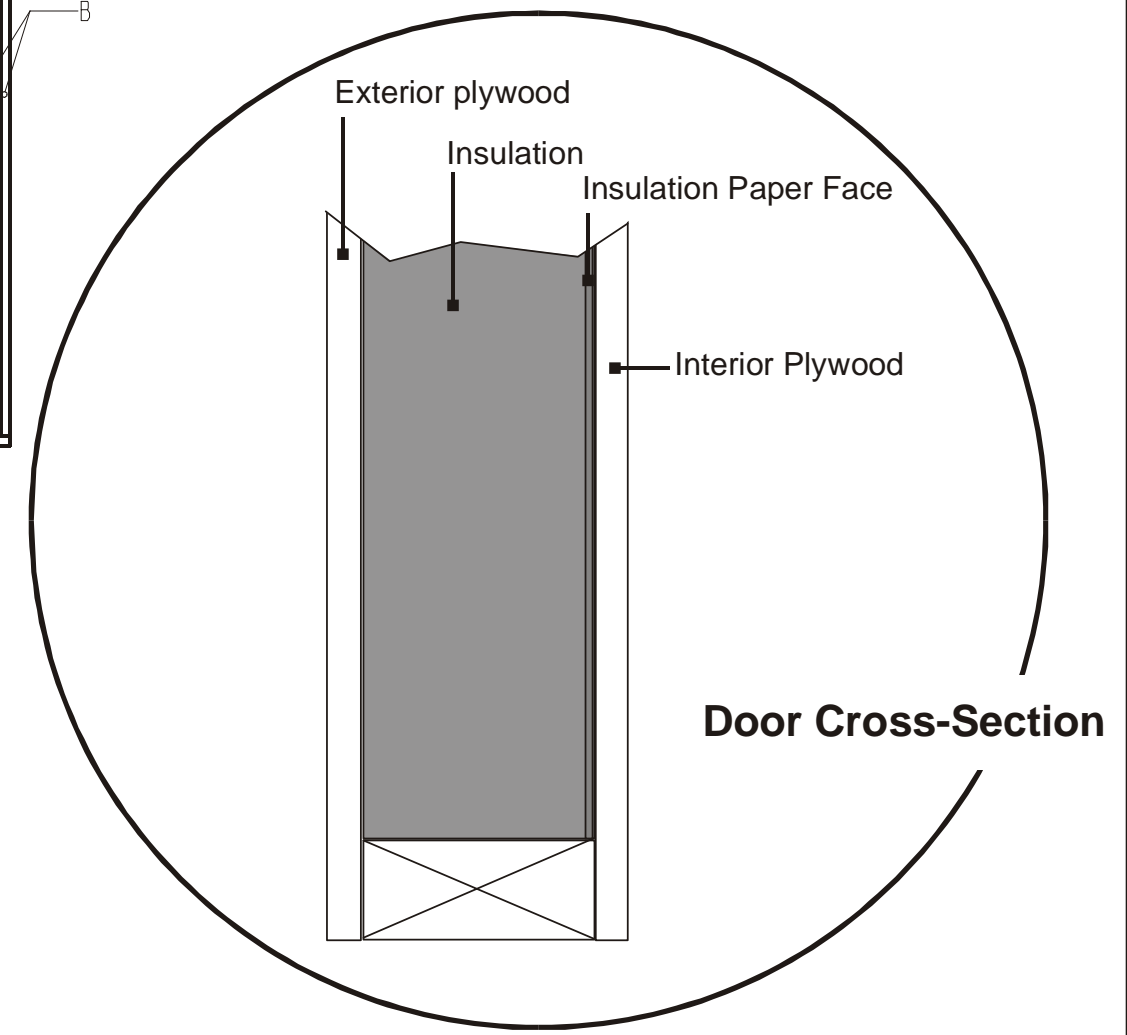

Mark interior side of doors

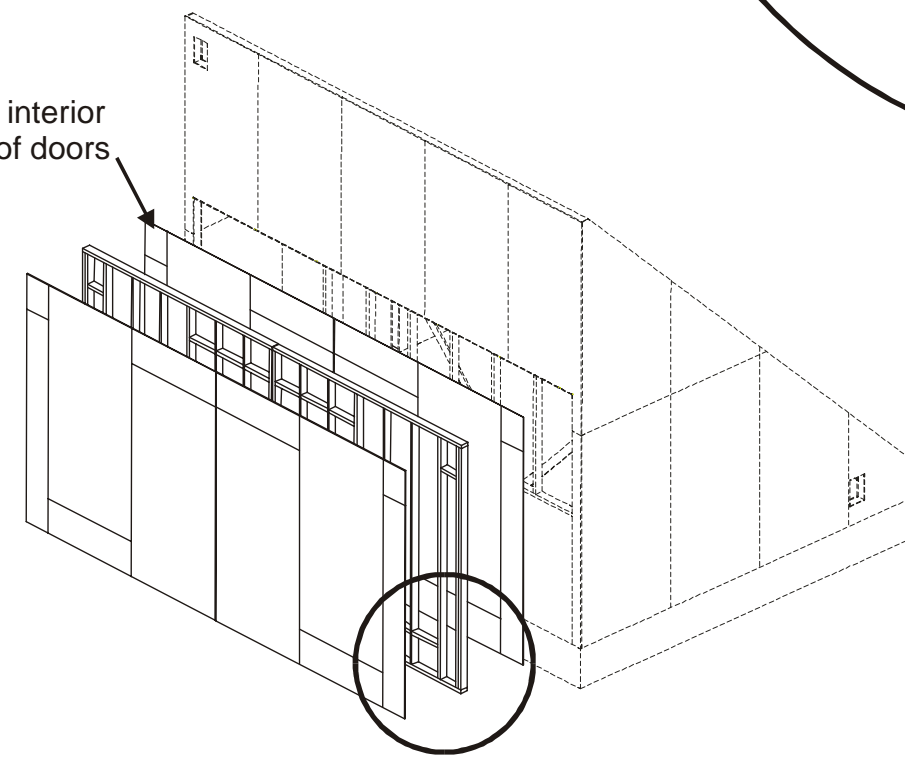

NOTE: See table for lumber lengths

Item	Qty	Length	Material
H	4	16"	2x4x8'
G	2	9 3/8"	
F	6	14 7/8"	2x4x8'
E	4	15 1/4"	2x4x8'
D	2	14 1/8"	
C	8	108 3/4"	1x4x10' (8)
B	10	108 3/4"	2x4x10' (10)
A	4	109 1/8"	2x4x10' (4)

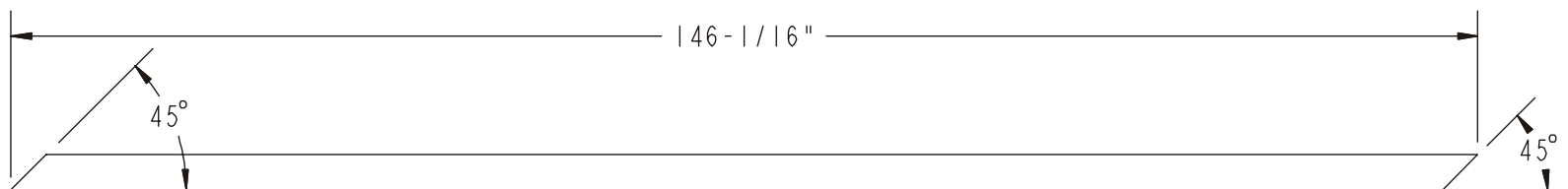
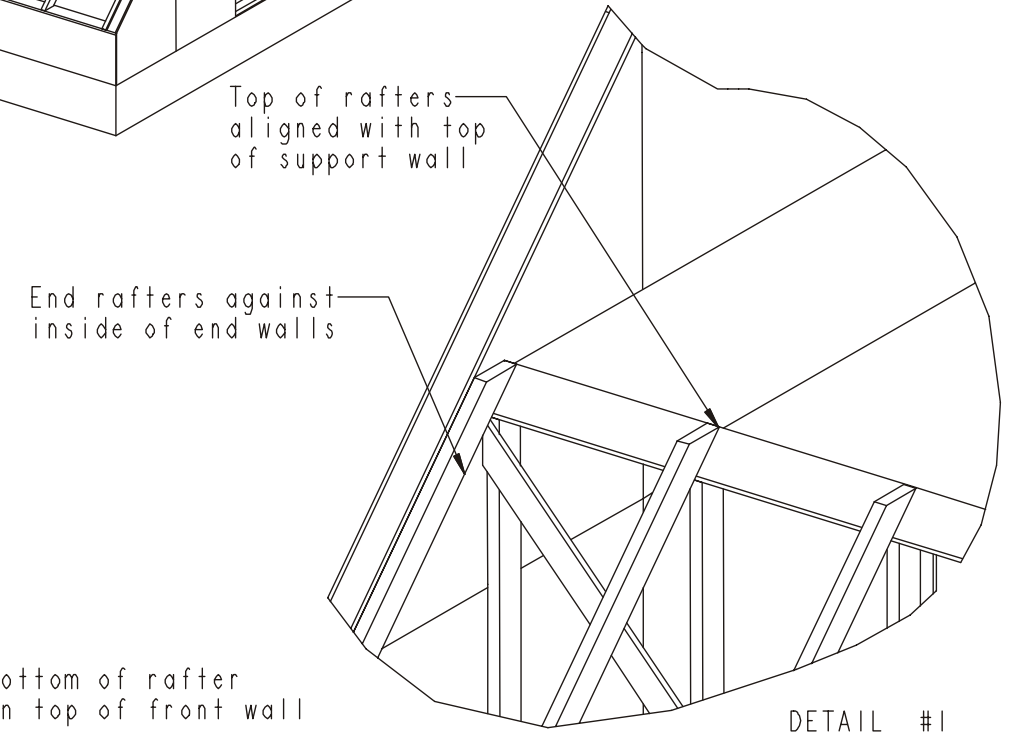
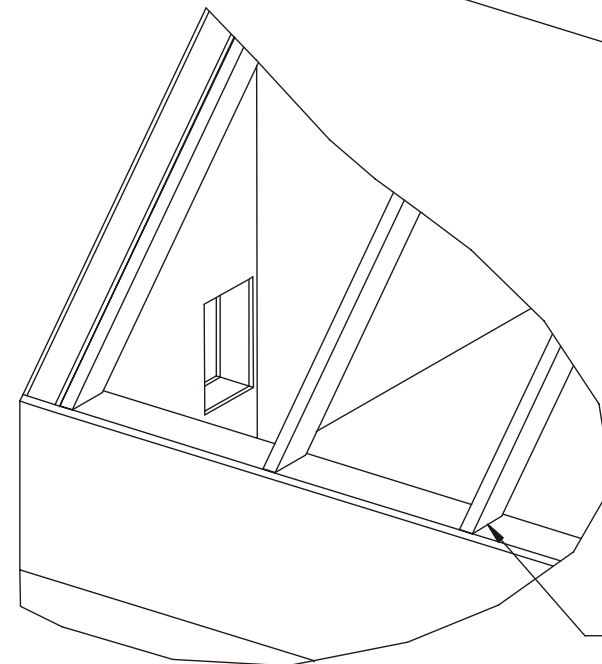
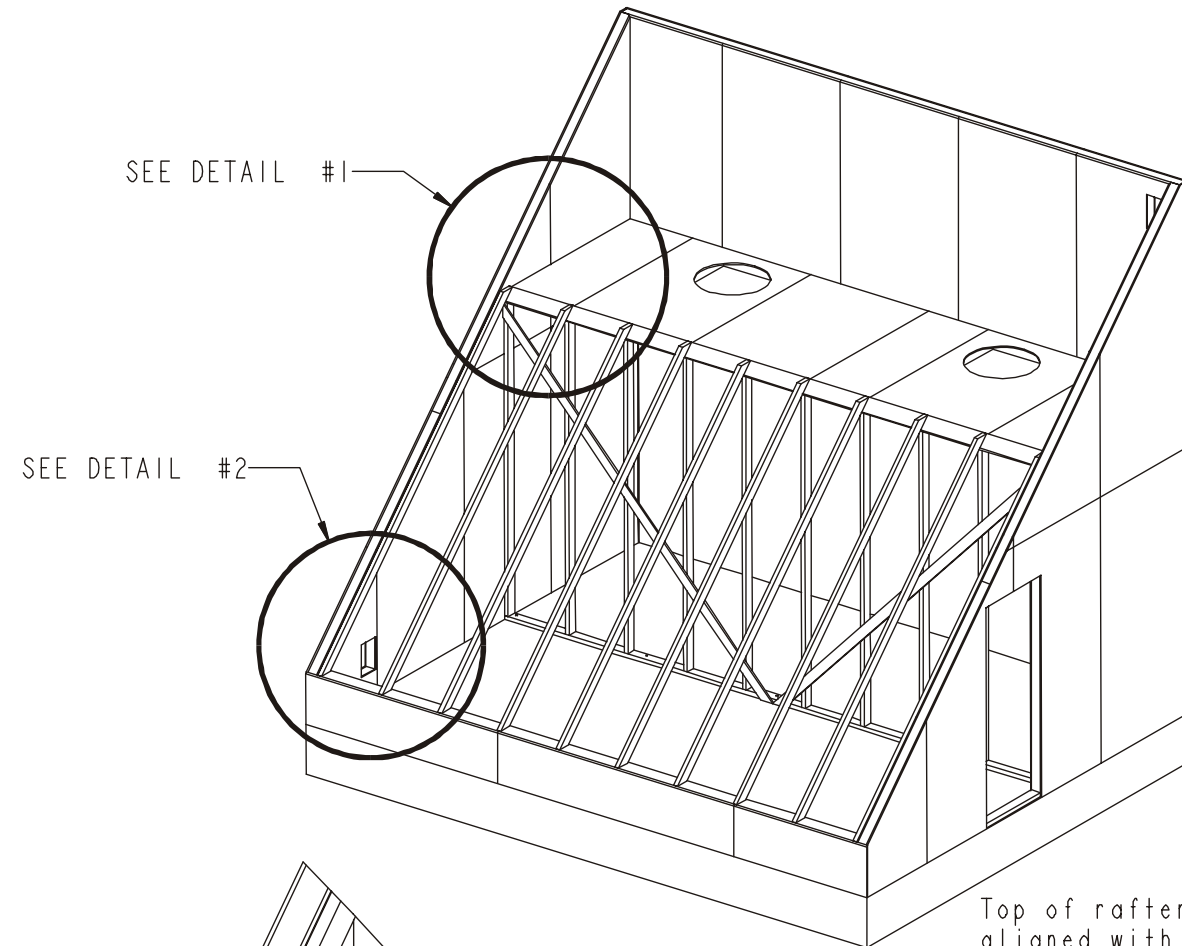
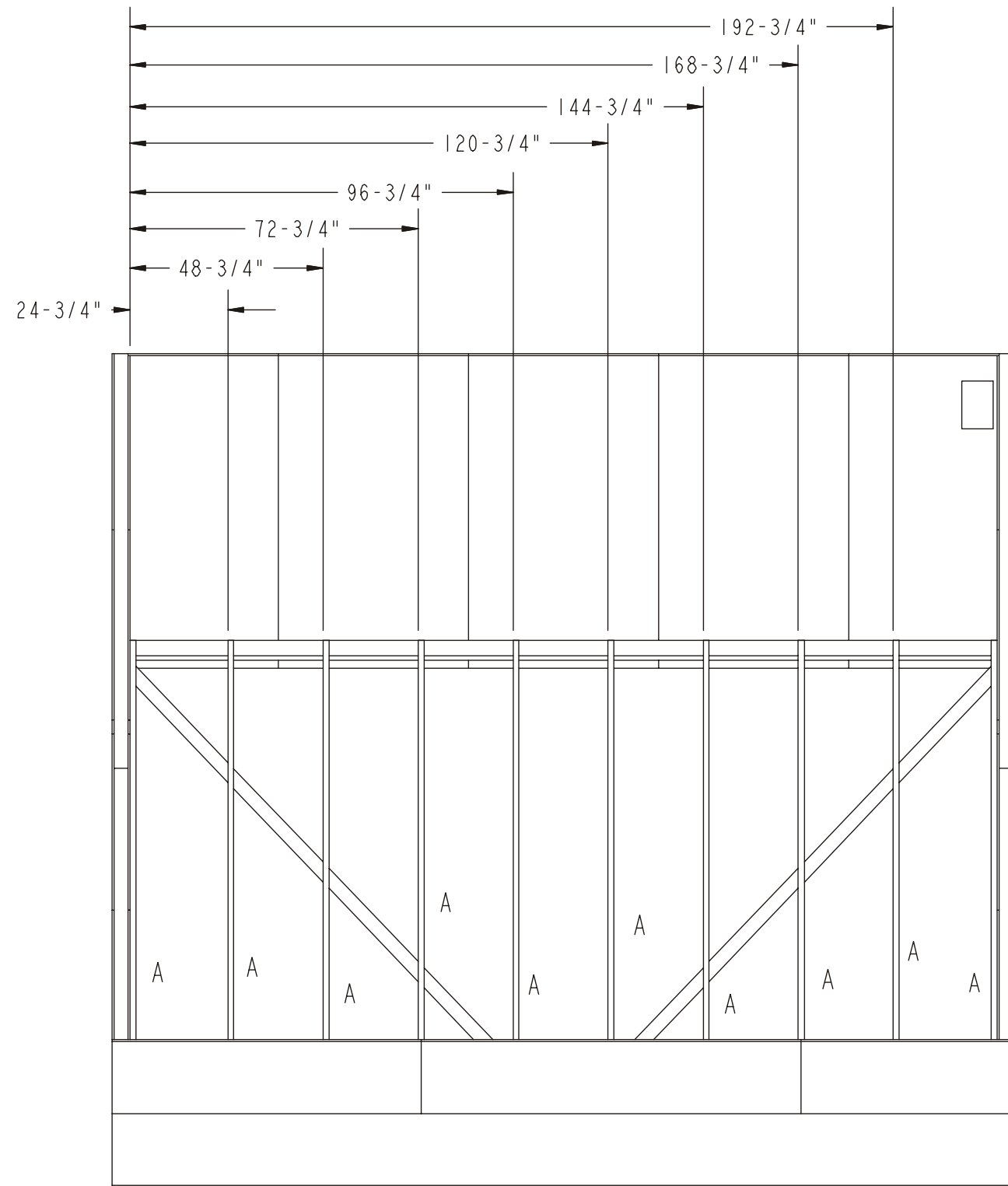

Item	Qty	Length	Material
A	10	146 1/16"	2x4x14' (10)

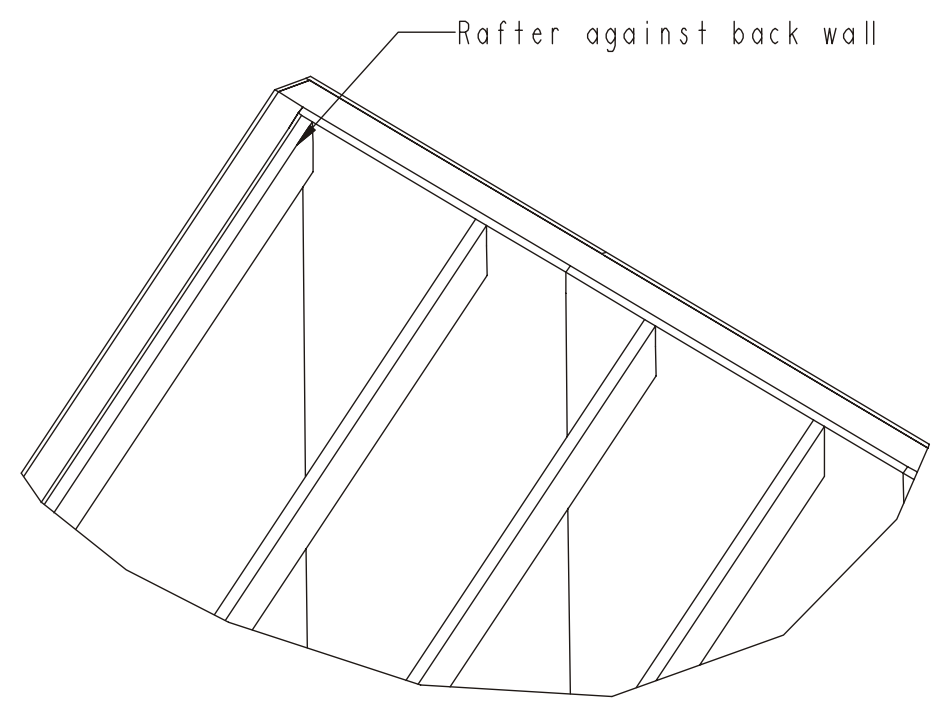
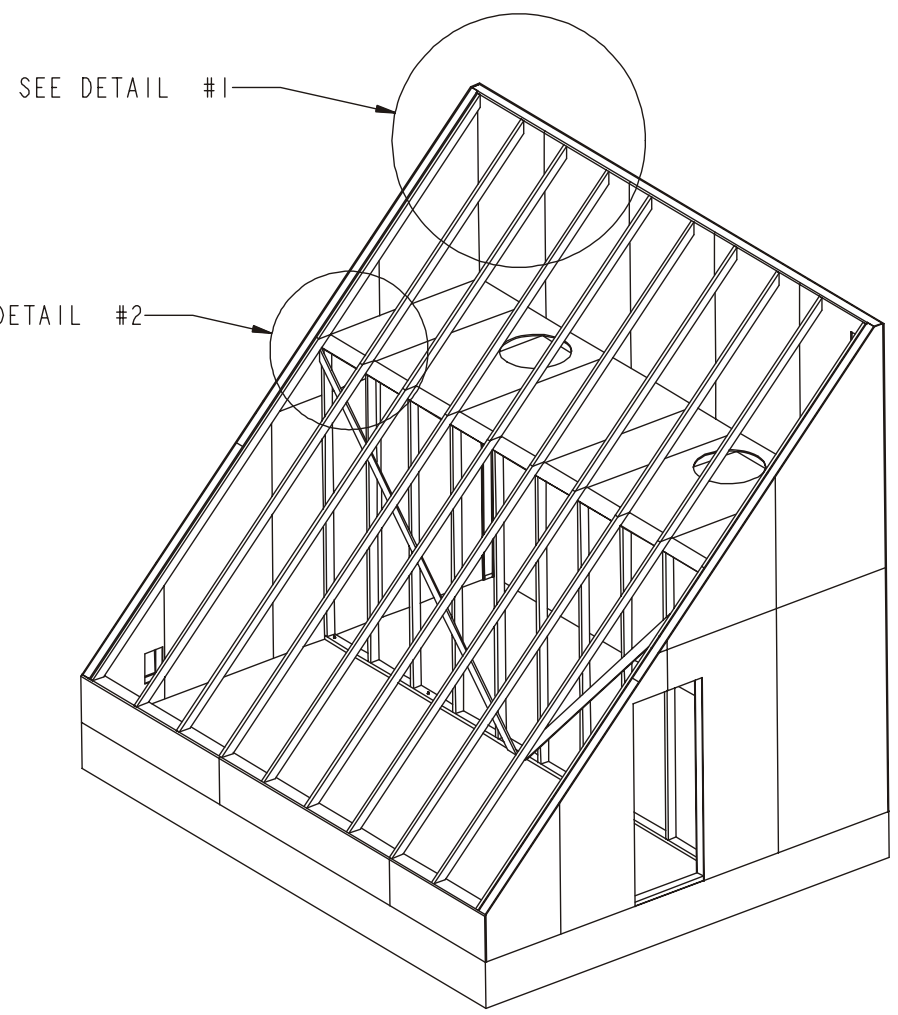
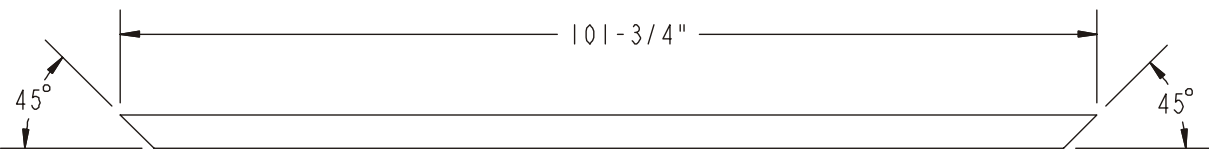
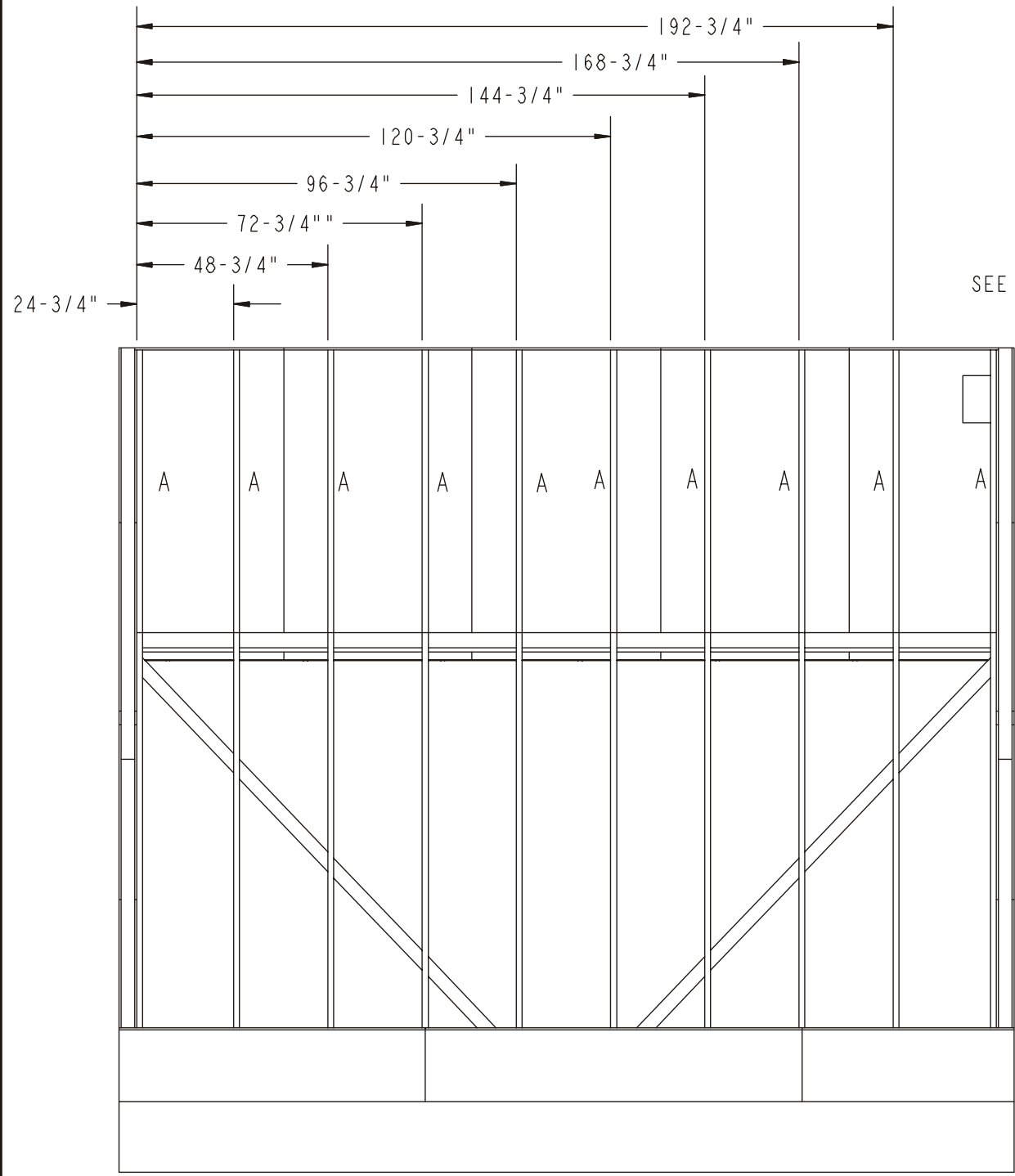

DETAIL #1

Align top rafter with bottom rafter

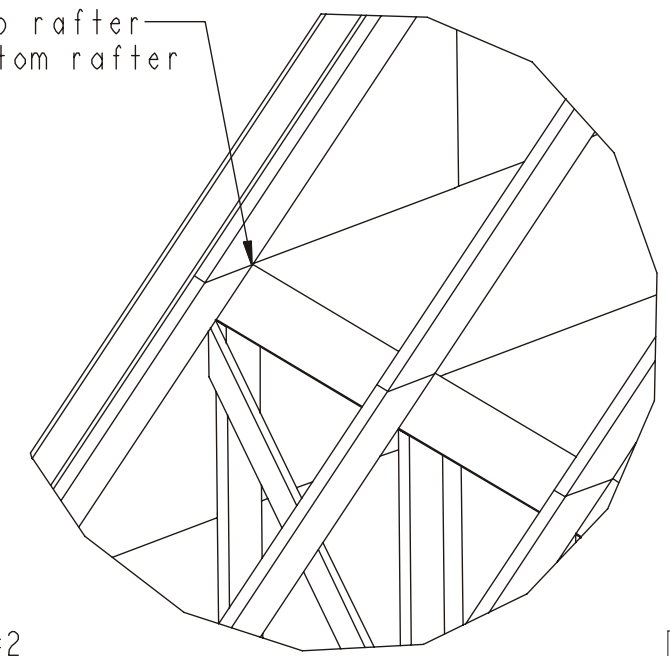

DETAIL #2

Item	Qty	Length	Material
A	10	101 3/4"	2x4x10' (10)

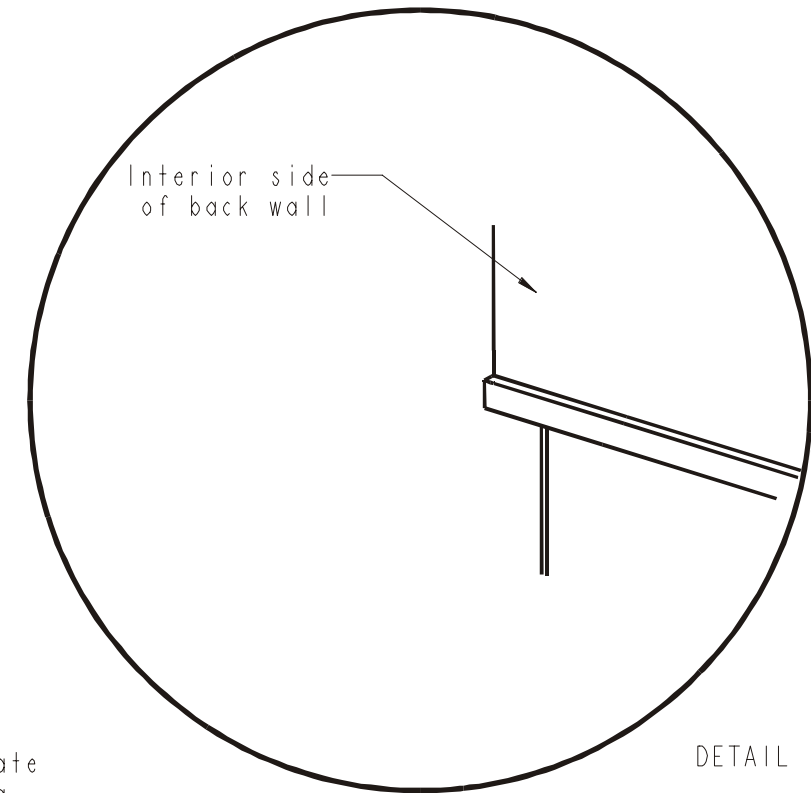
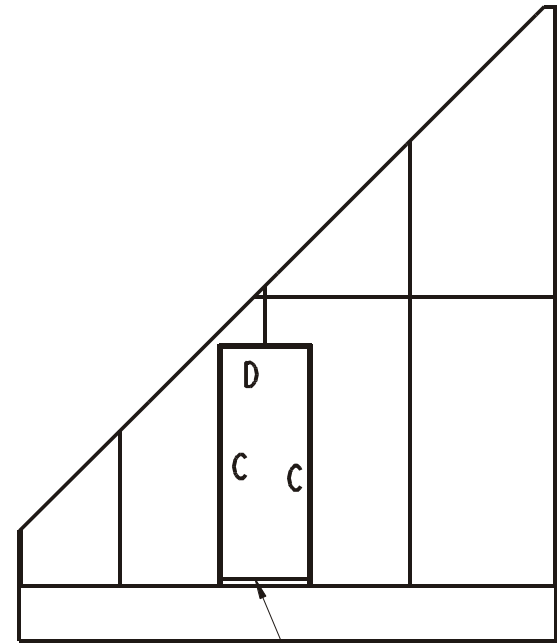
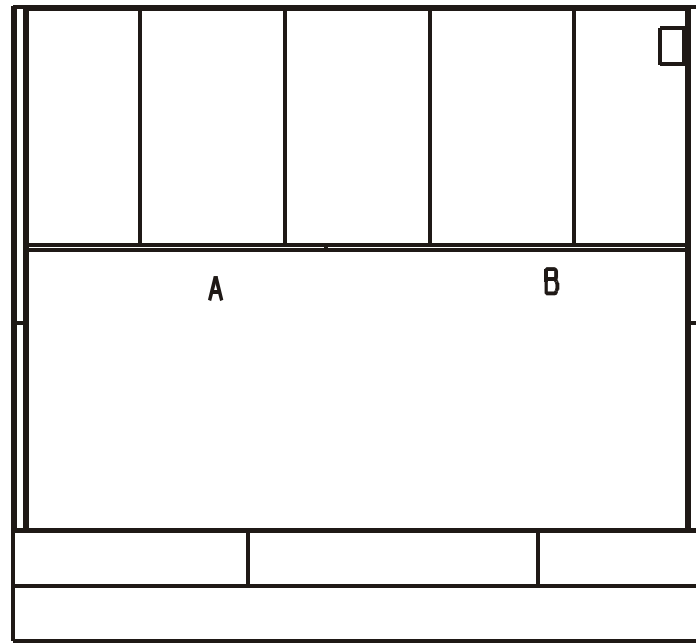

DETAIL #1

Remove sill plate in door opening

NOTE: Views shown without interior wall, front wall, and rafters for clarity

SEE DETAIL #1

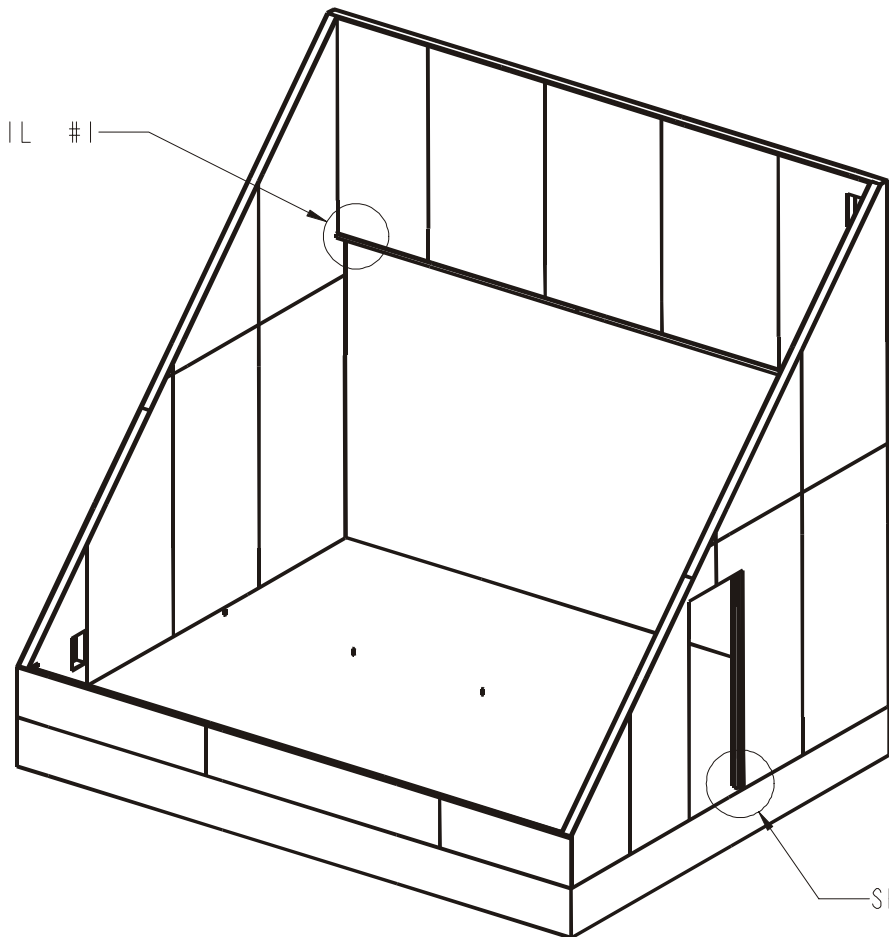

SEE DETAIL #2

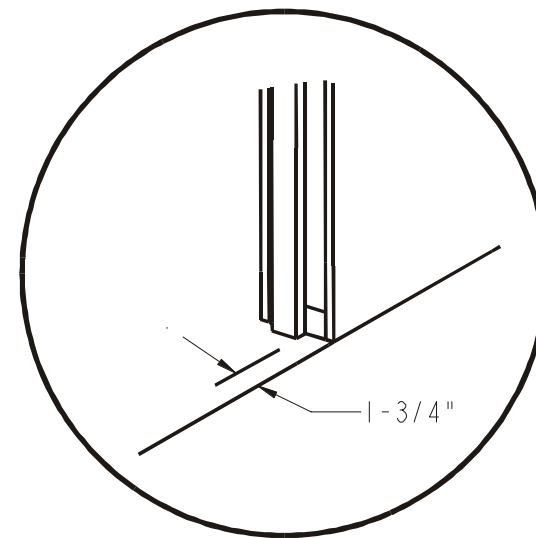

DETAIL #2

NOTE: See table for lumber lengths

Item	Qty	Length	Material
D	1	30 1/2"	1x2x10' Cedar (2)
C	2	79 1/4"	
B	1	120"	1x2x10' Cedar
A	1	99"	1x2x10' Cedar

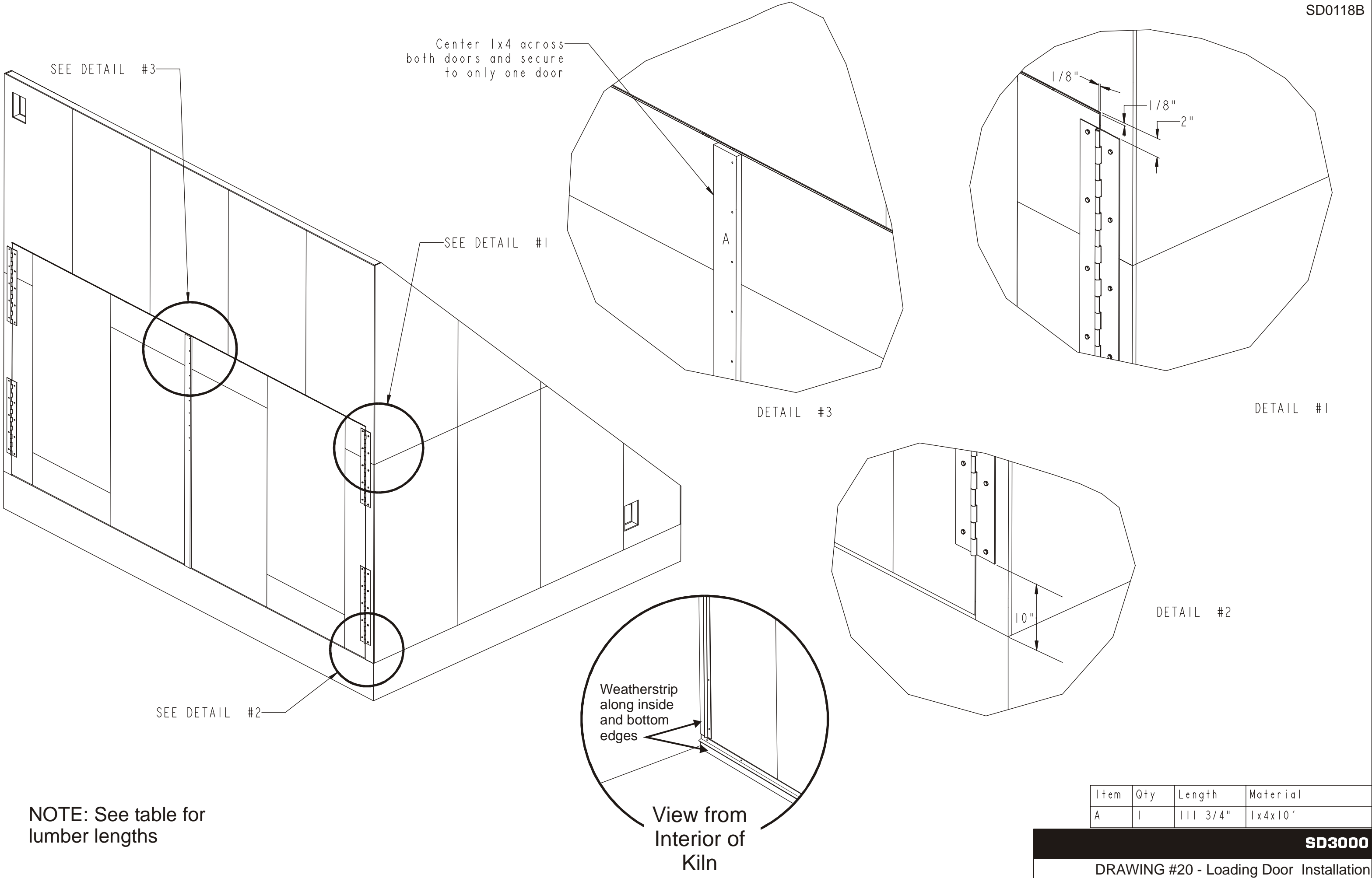

SEE DETAIL #3

Center 1x4 across both doors and secure to only one door

SEE DETAIL #1

A

DETAIL #3

1/8"

1/8"

2"

DETAIL #1

SEE DETAIL #2

10"

DETAIL #2

Weatherstrip along inside and bottom edges

View from Interior of Kiln

NOTE: See table for lumber lengths

Item	Qty	Length	Material
A	1	111 3/4"	1x4x10'

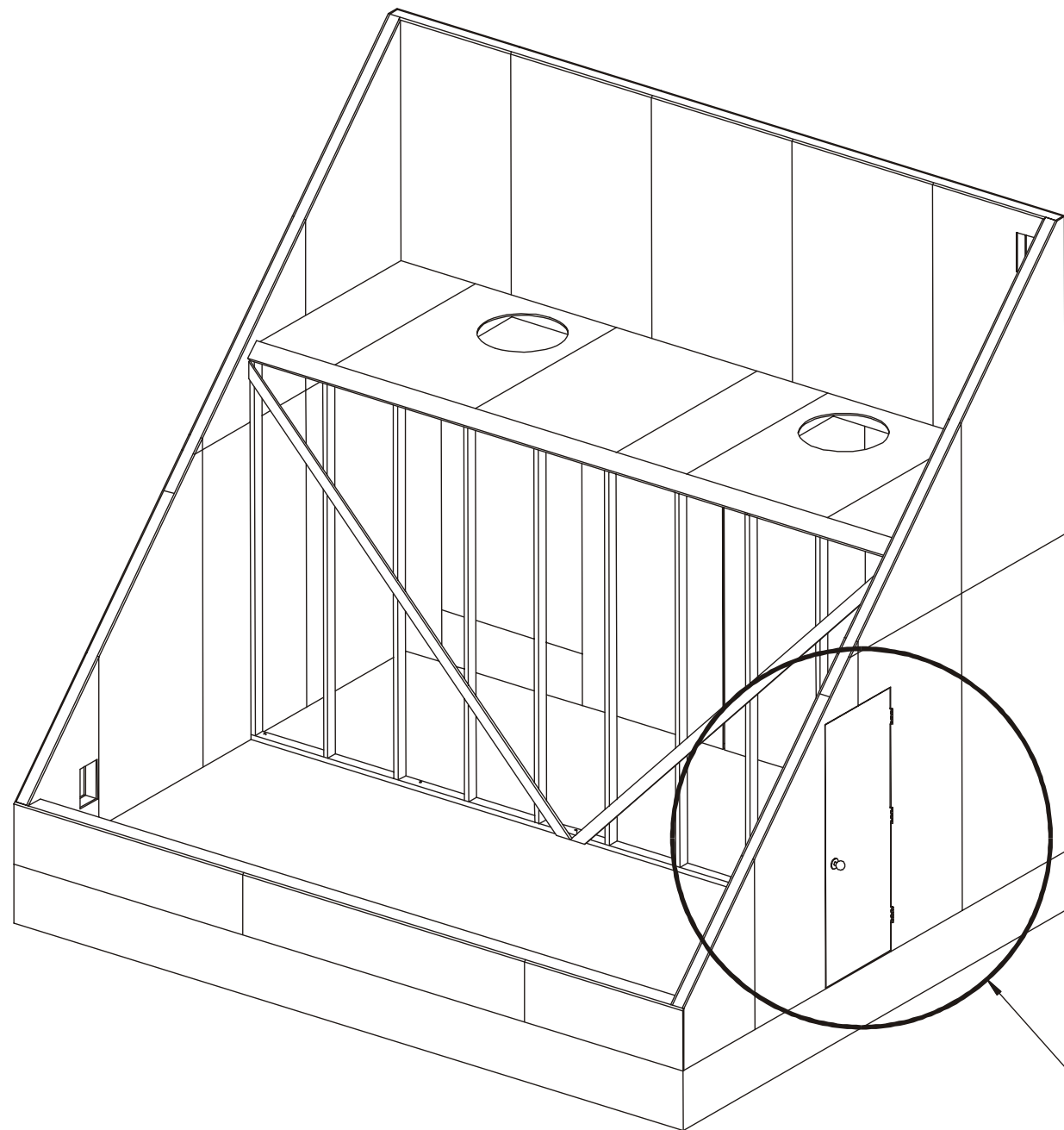

SEE DETAIL #1

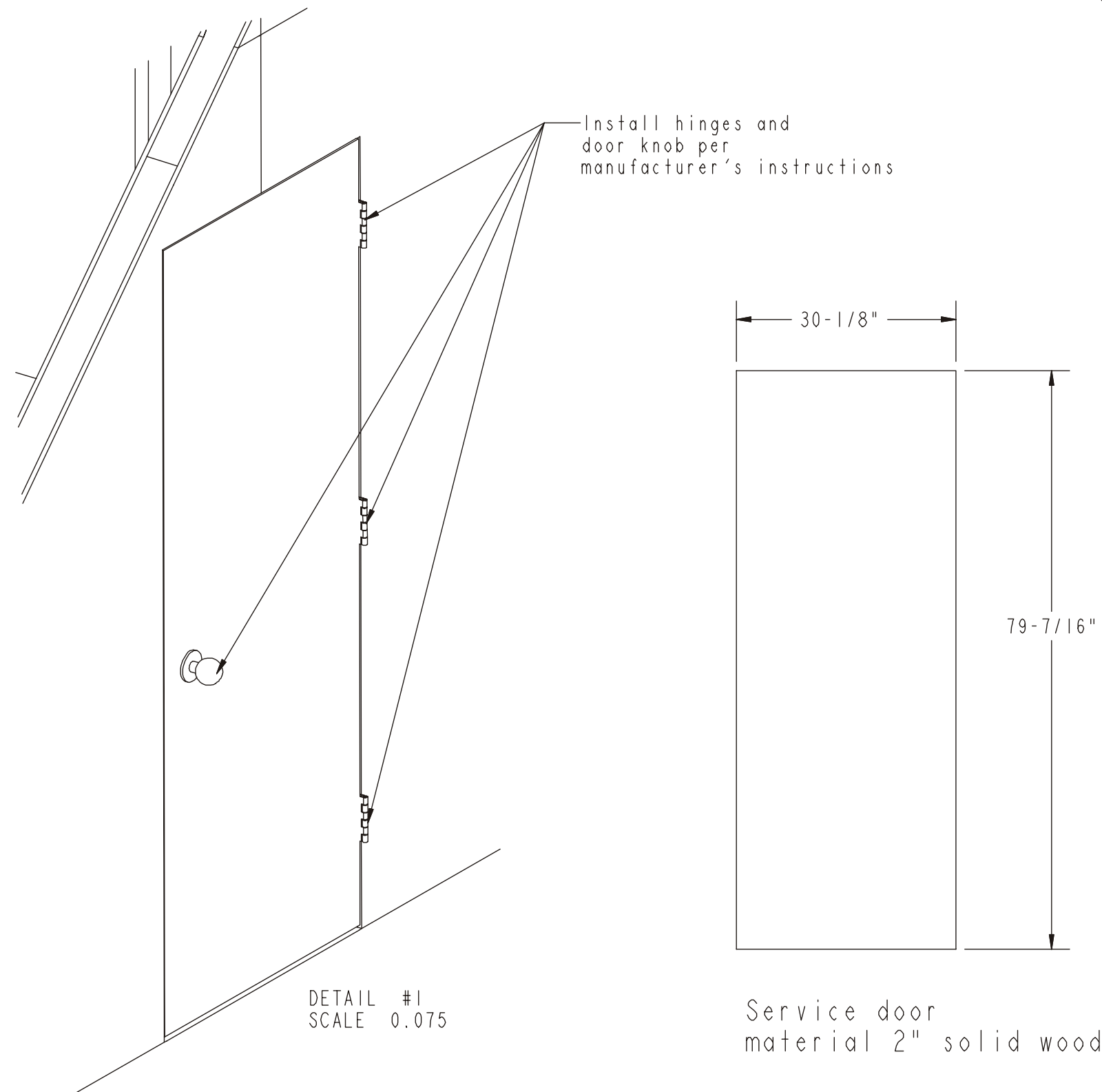

DETAIL #1
SCALE 0.075

Install hinges and door knob per manufacturer's instructions

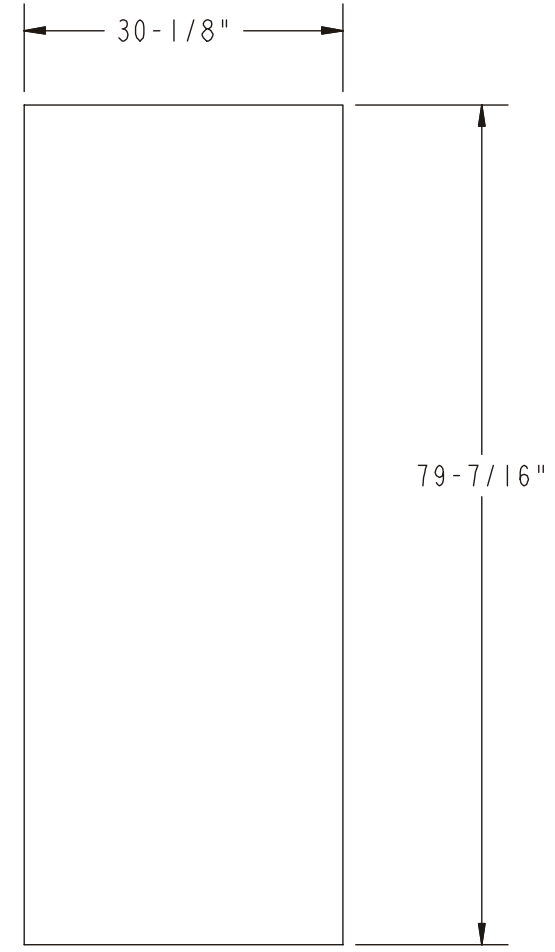

Service door material 2" solid wood

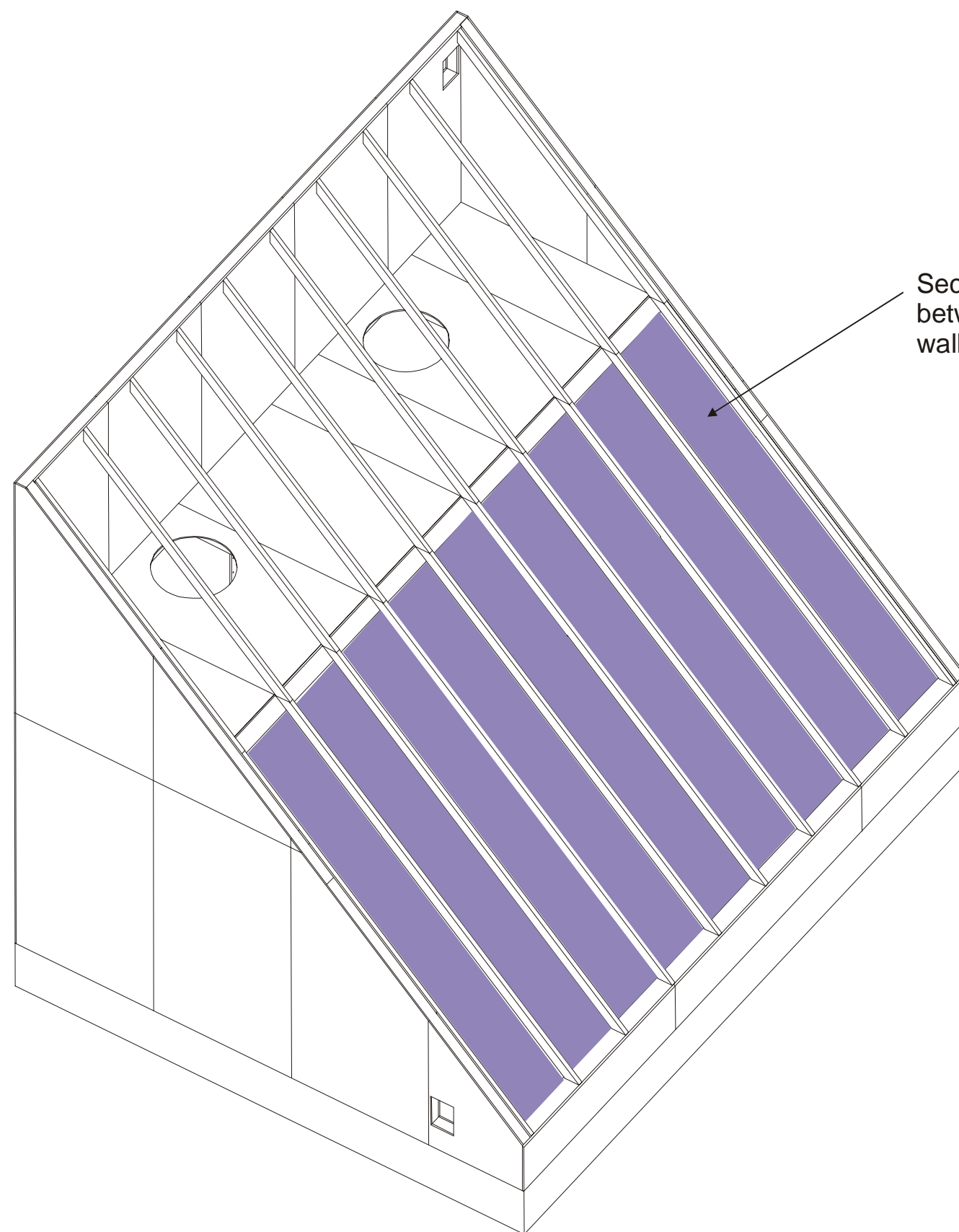

Secure screen to bottom of rafters
between middle support wall and front
wall (18.5' x 11.5' or 213 Sq. Ft.)

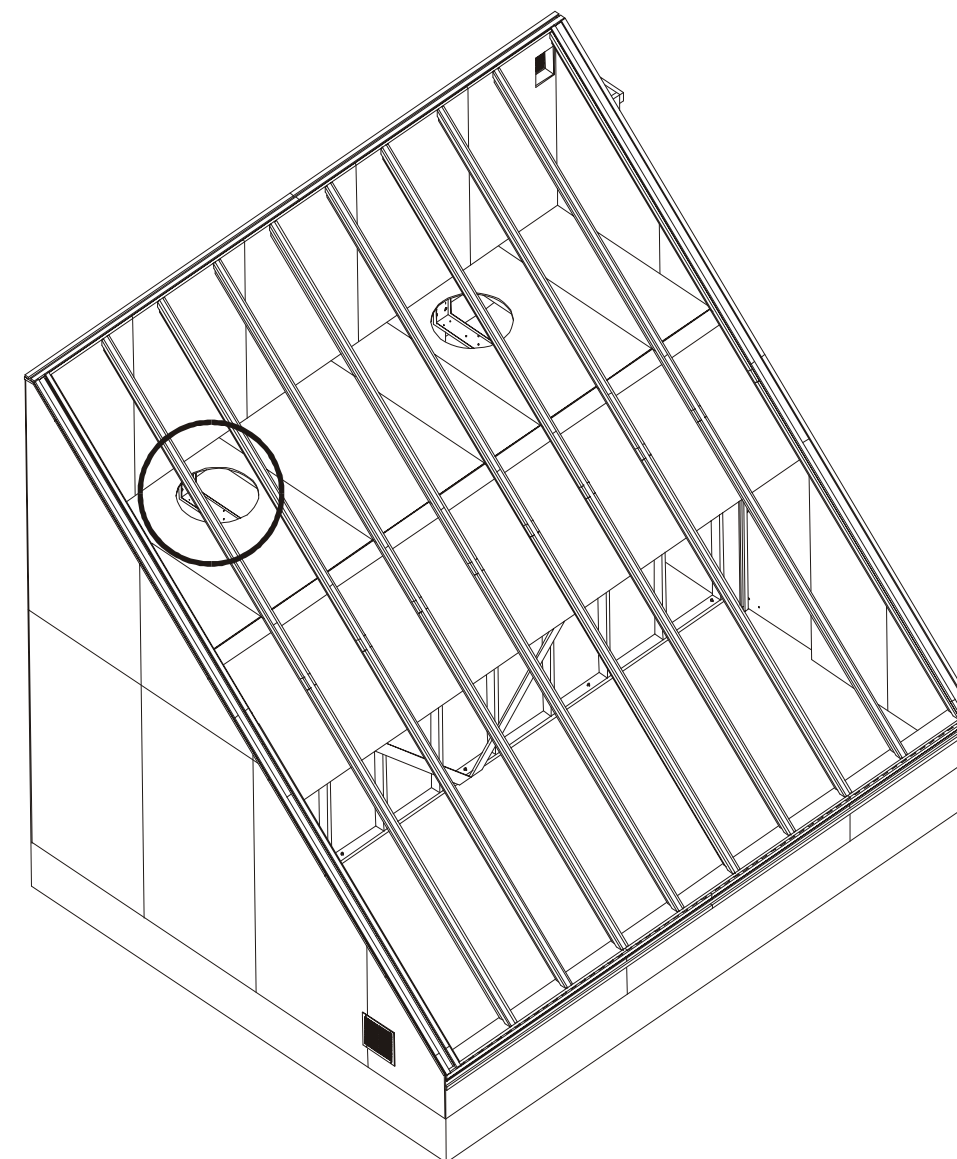
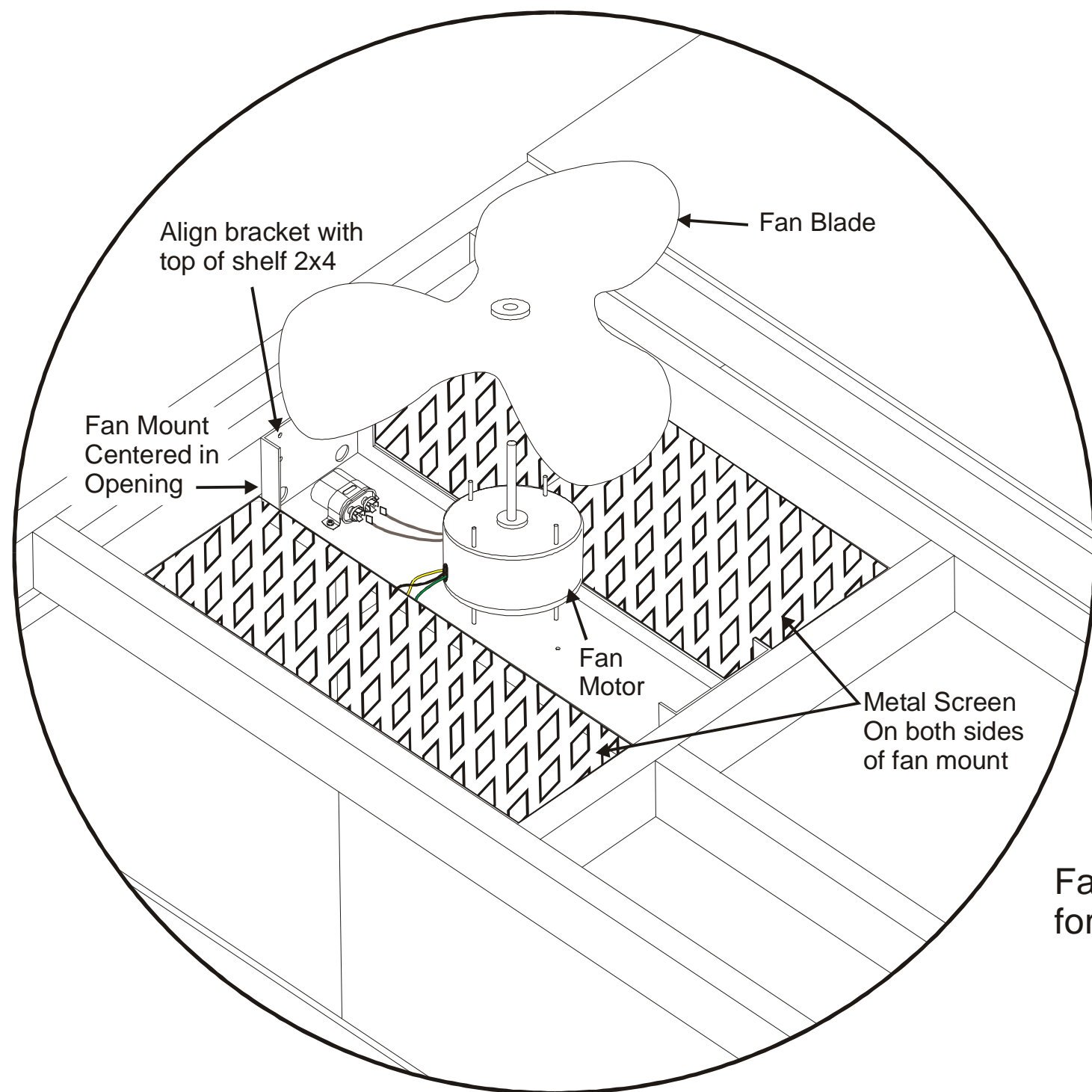

Fan Detail - Plywood removed for clarity

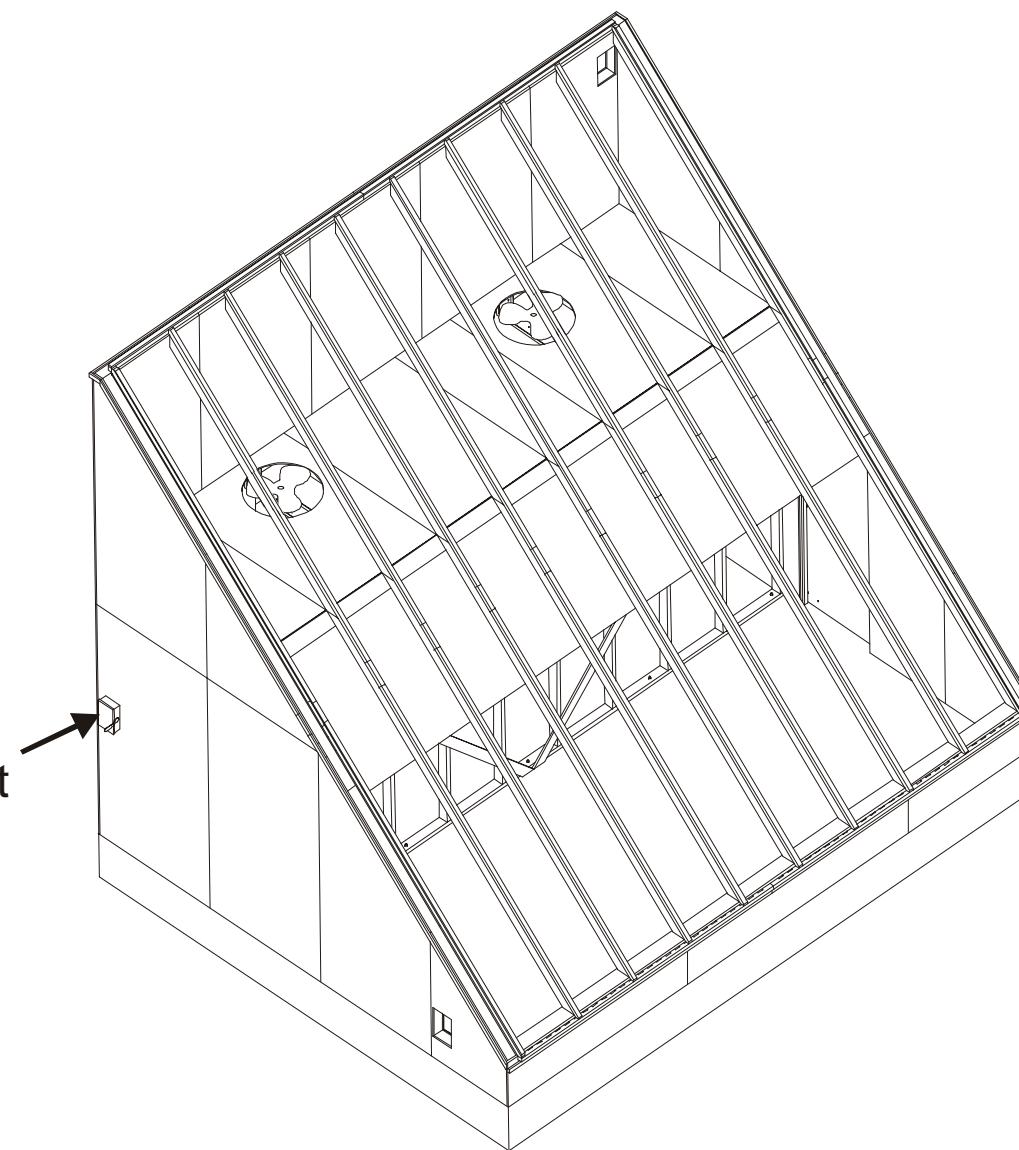
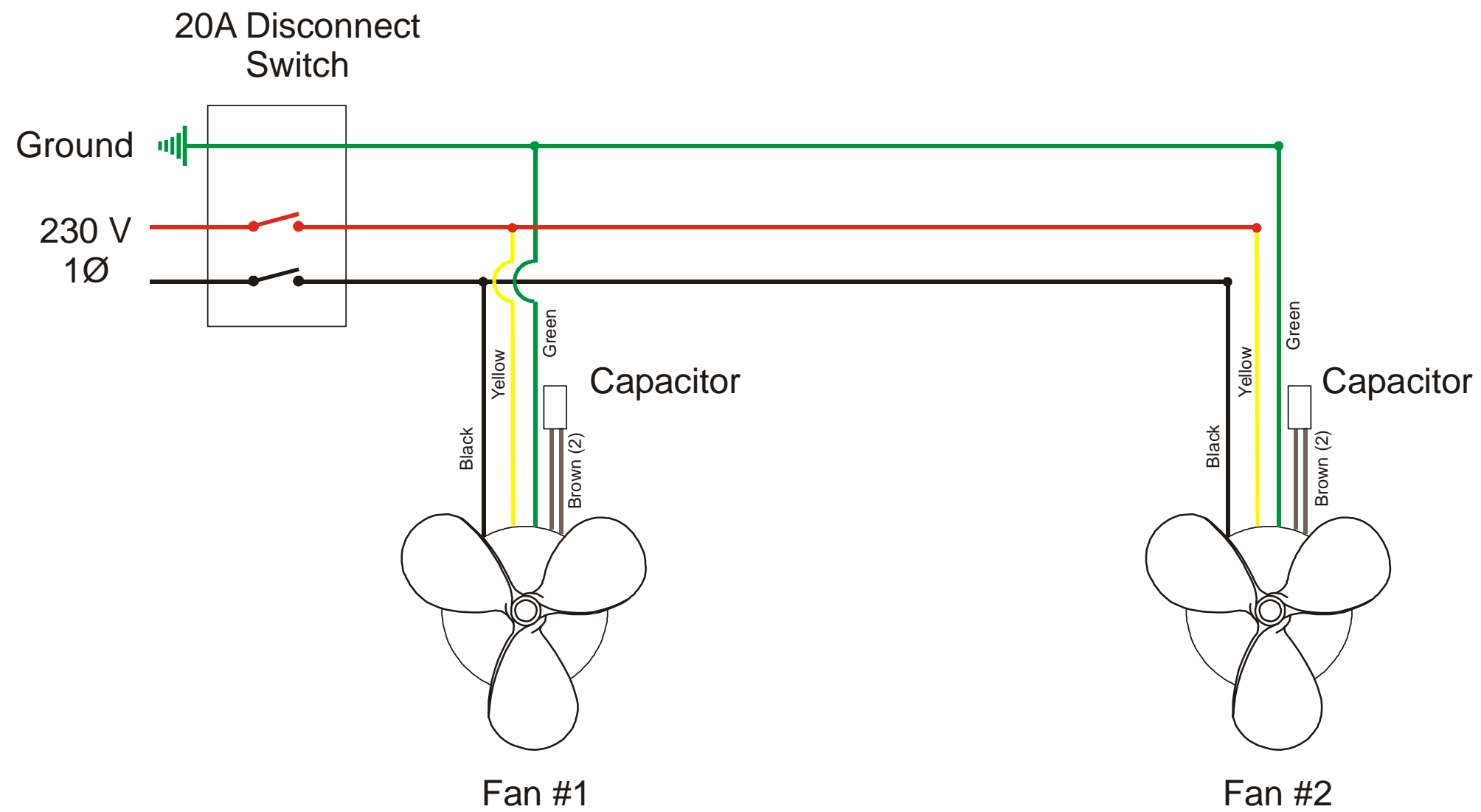

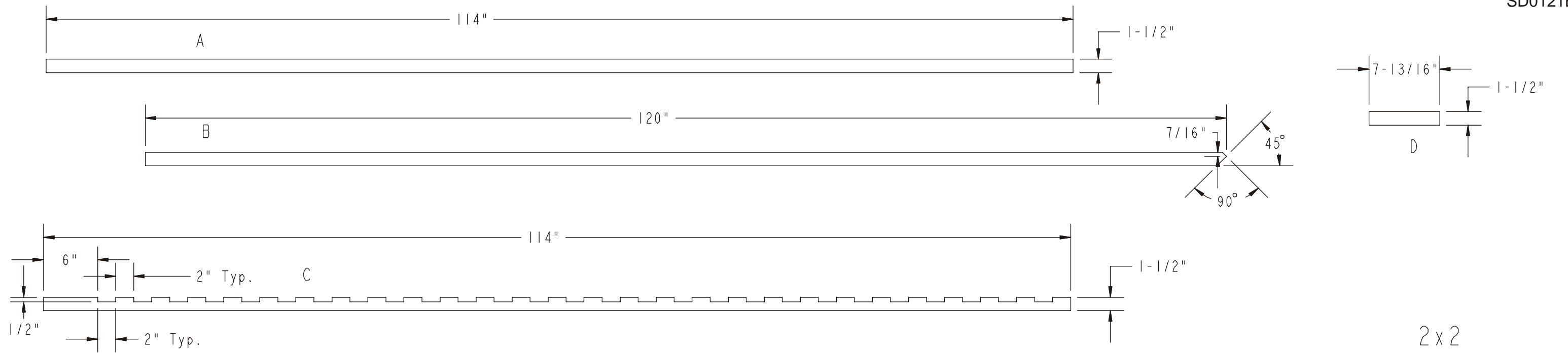

2x2

1x2

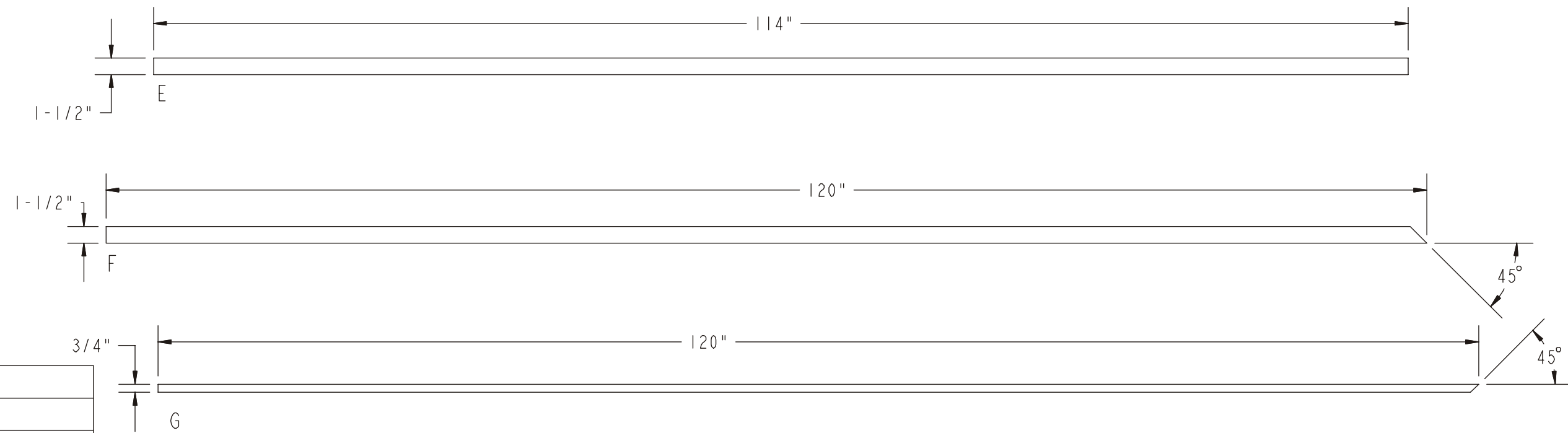

Item	Qty	Length	Material
J	2	6-31/32"	1x2
I	2	7-3/16"	1x2
H	2	4-3/4"	1x2
G	4	120"	1x2x10' Cedar (4)
F	4	120"	1x2x10' Cedar (4)
E	6	114"	1x2x10' Cedar (6)
D	10	7-13/16"	2x2x10'
C	2	114"	2x2x10' (2)
B	20	120"	2x2x10' (20)
A	2	120"	2x2x10' (2)

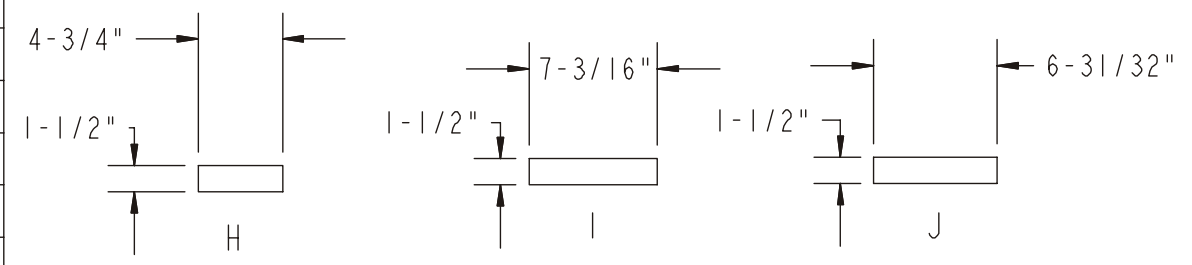

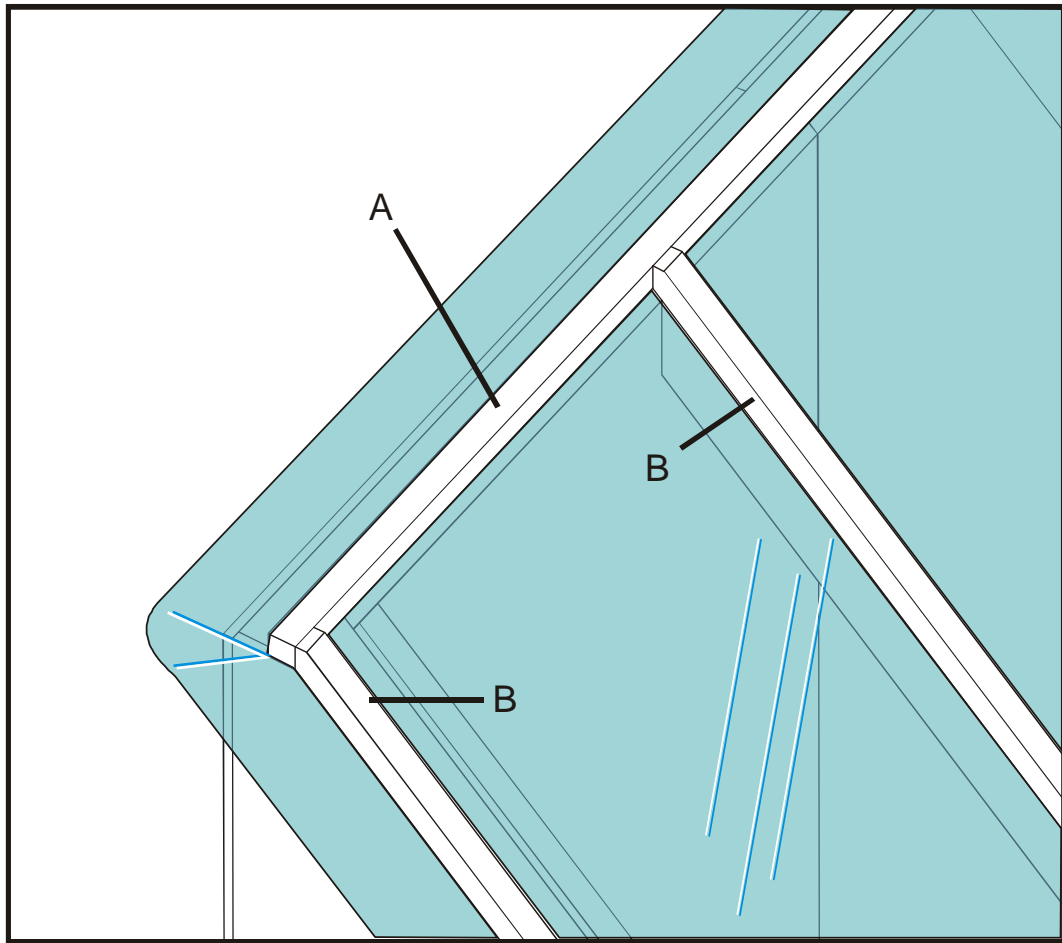

DETAIL #1

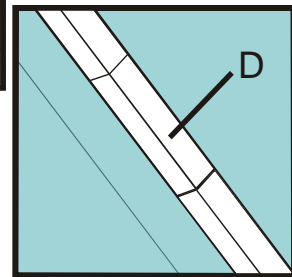

DETAIL #3

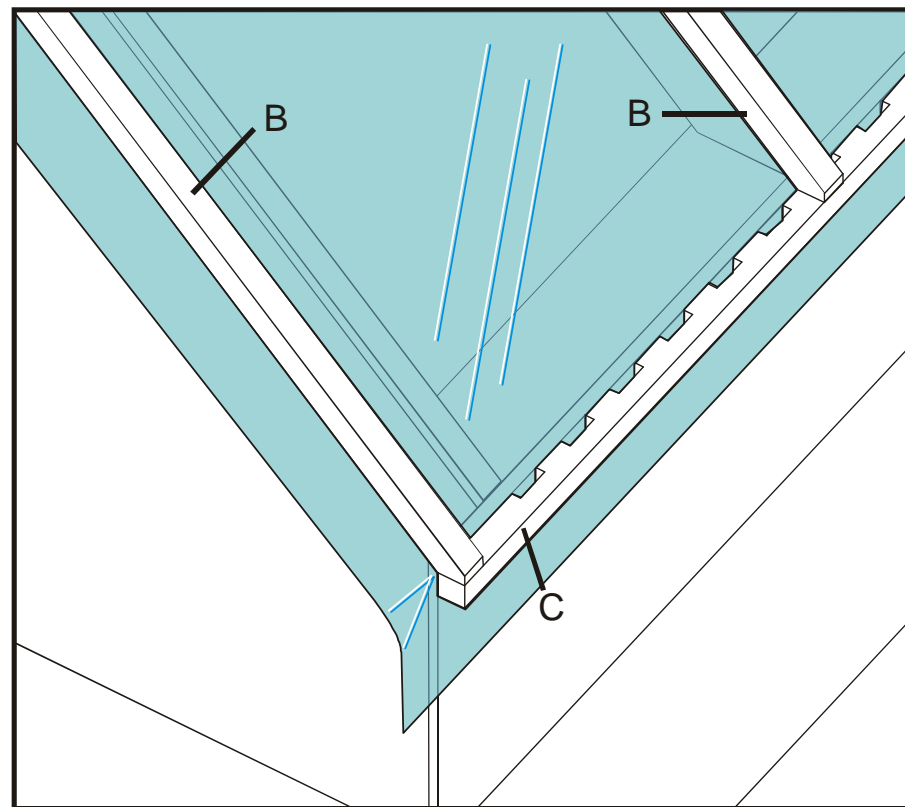

DETAIL #2

SEE DETAIL #1

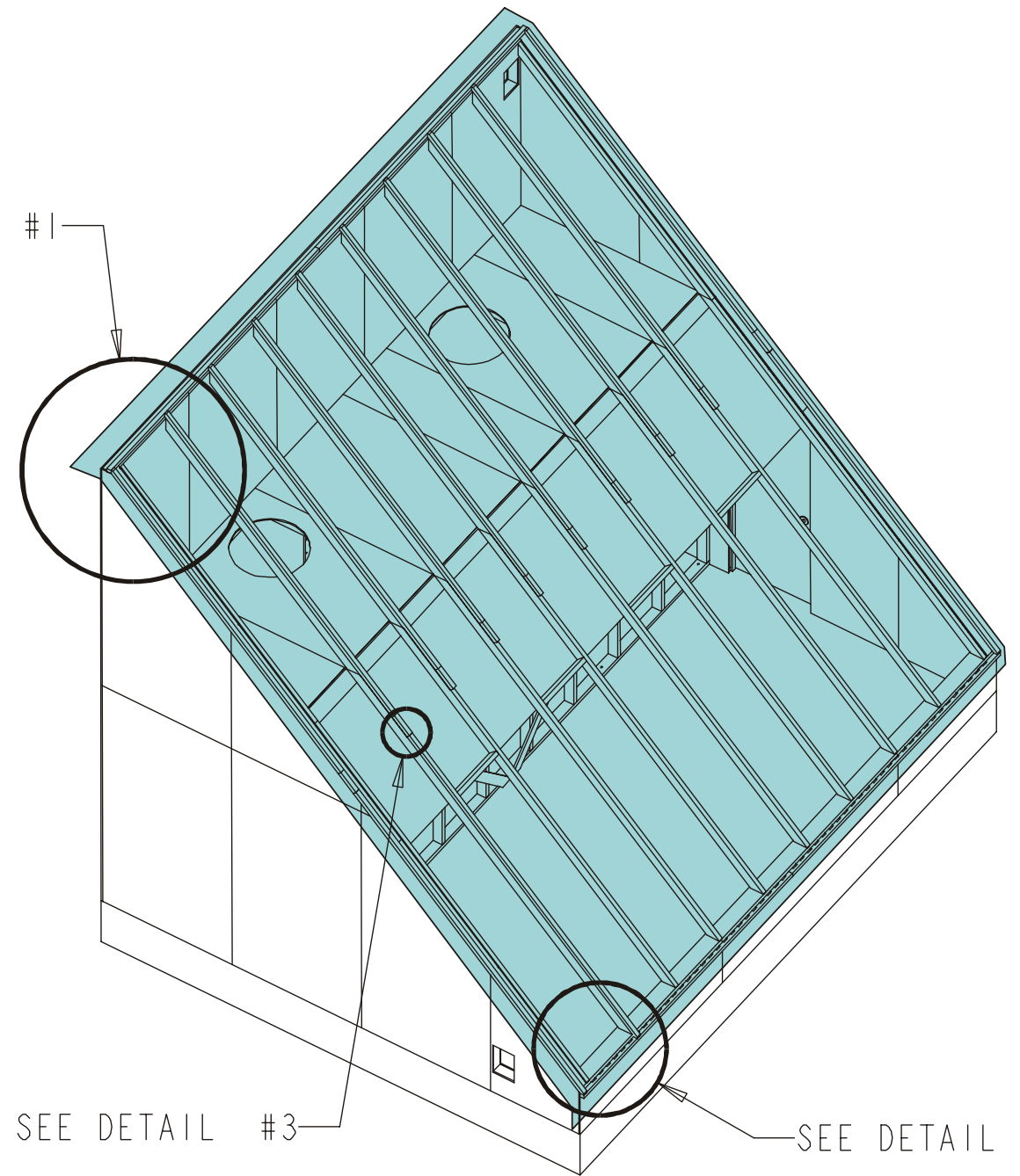

SEE DETAIL #3

SEE DETAIL #2

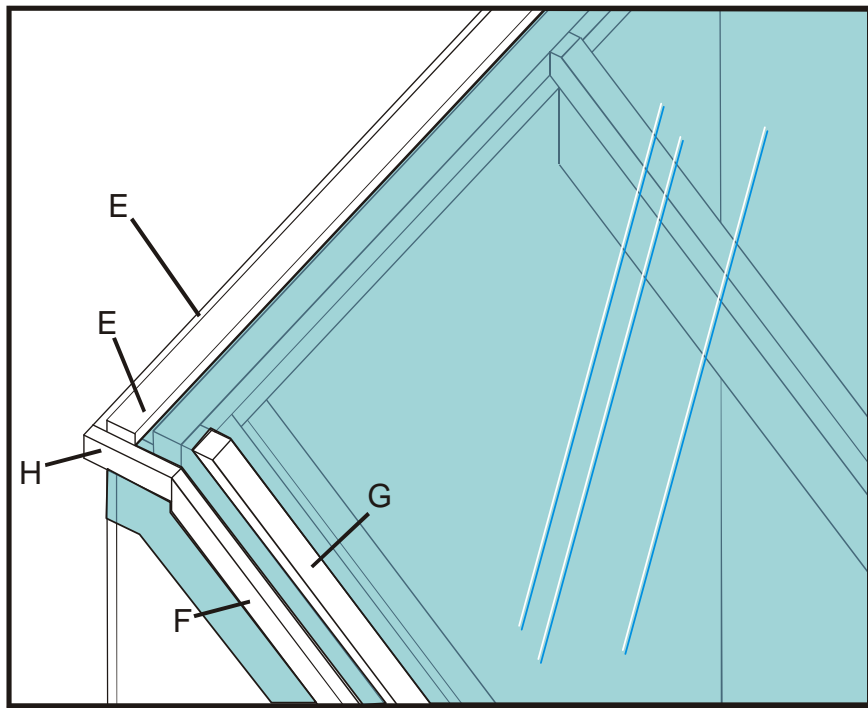

DETAIL #1

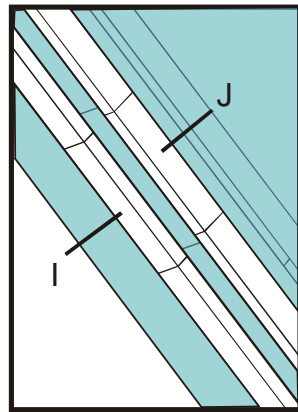

DETAIL #3

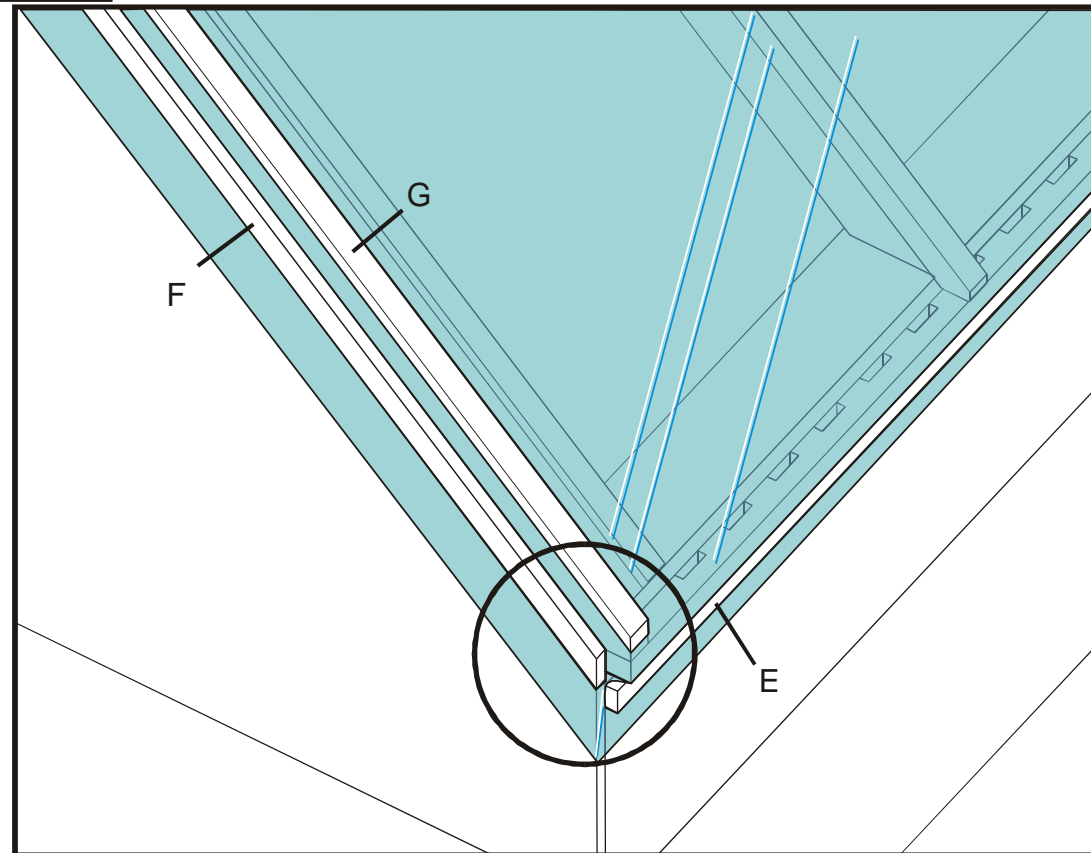

DETAIL #2

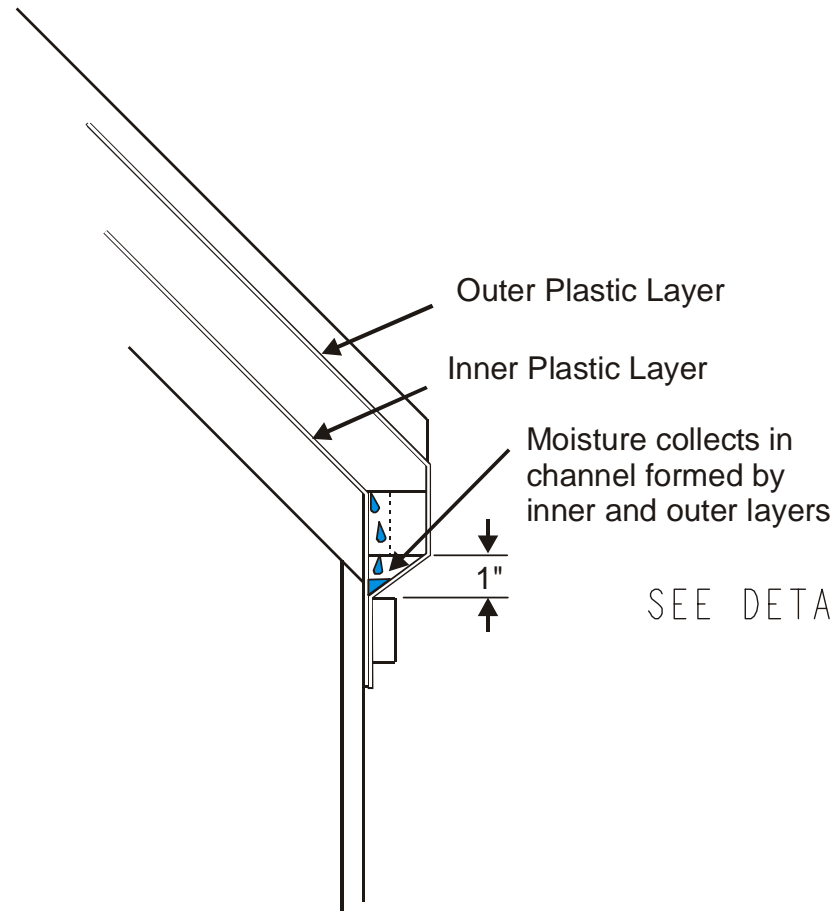

SEE DETAIL #1

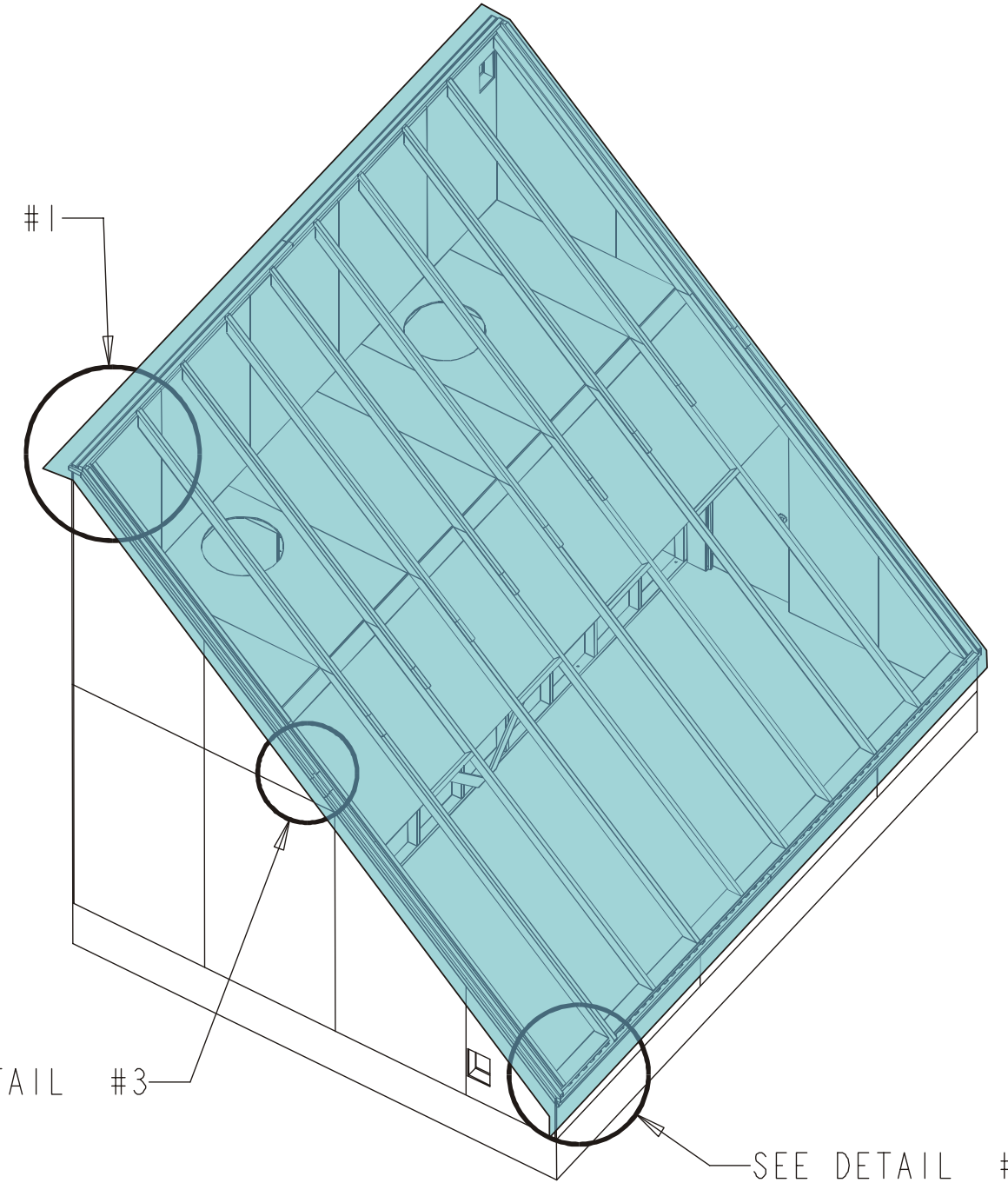

SEE DETAIL #3

SEE DETAIL #2

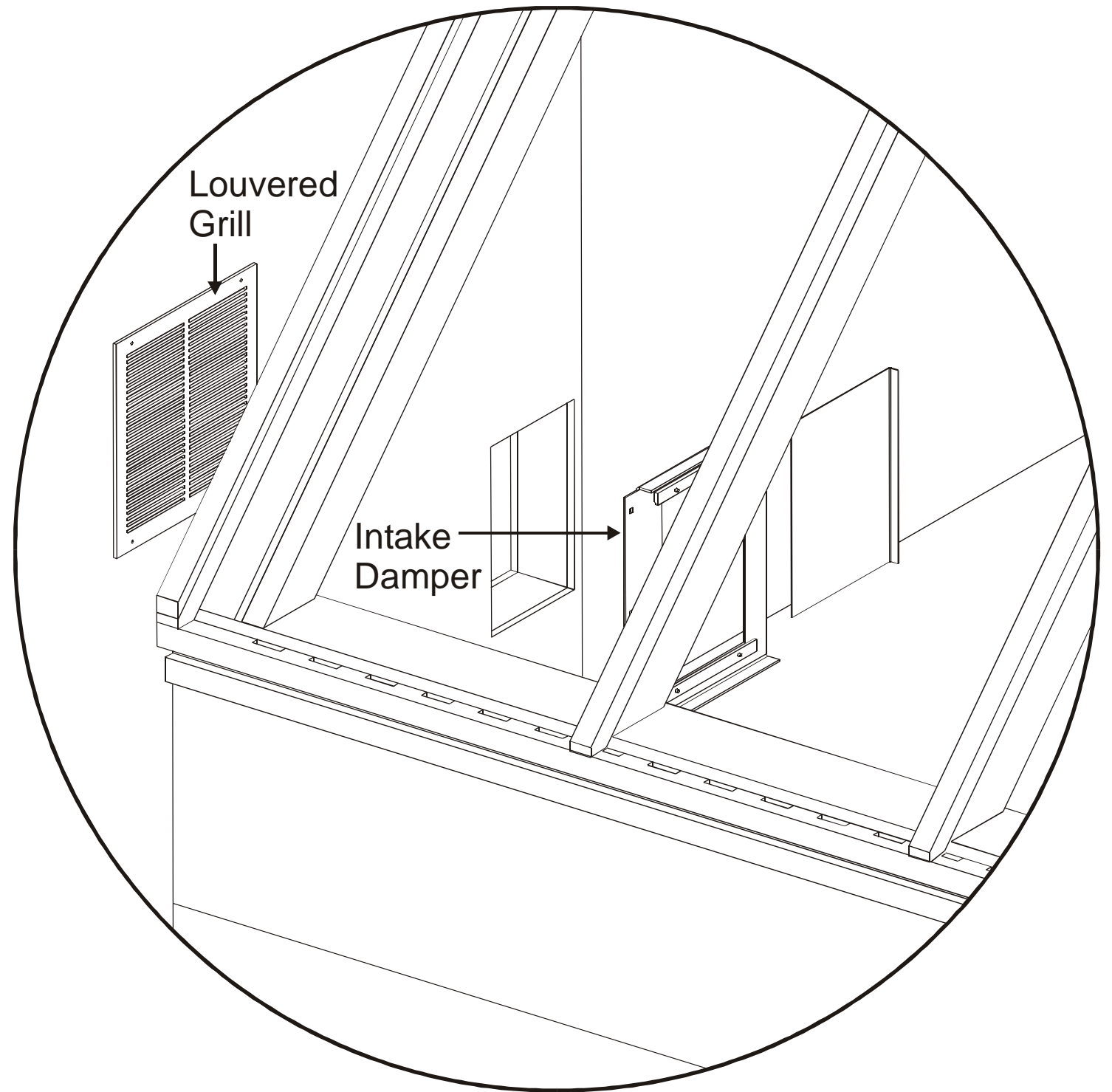
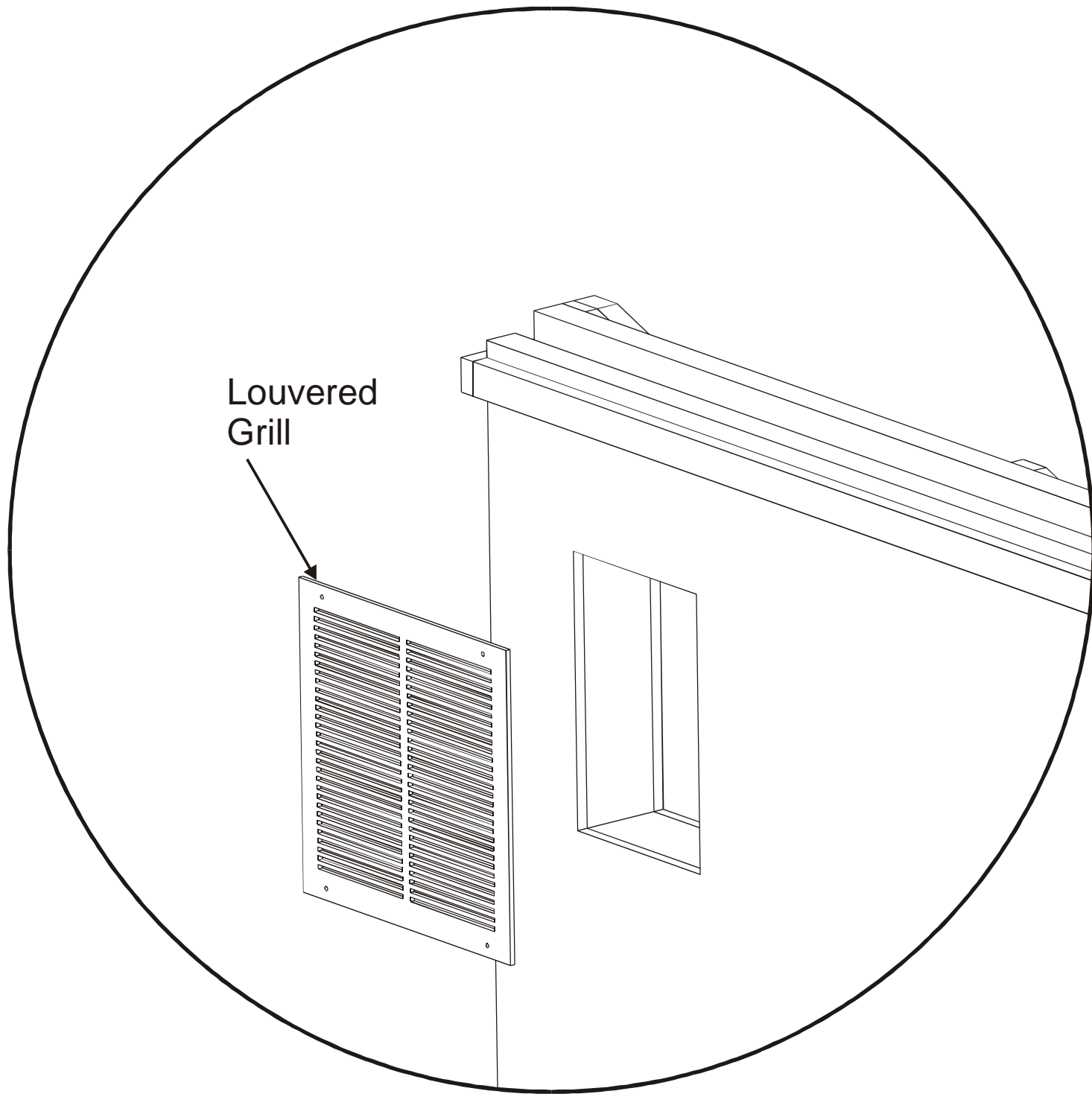

SOLAR KILN COMMON PARTS FOR
SD9, 18, 27, 36 JUNIOR

<u>Description</u>	<u>Part Number</u>
Blade Fan	P02647
Blower (inflation) 4C565	P02557
Blower Assy (w/duct)	A02649
Capacitor, 6x653 Uf (circulation motor)	P02675
Extrusion (film clamp)	R01778
Fan Motor (circulation) 4M105	P02646
Plastic Covers	SDC9
	SDC18
	SDC27
	SDC36

SOLAR KILN COMMON PARTS FOR
SD9, 18, 27, 36 SENIOR

<u>Description</u>	<u>Part Number</u>
Blade Fan	P02549
Blower (inflation) 4C565	P02557
Blower Assy (w/duct)	A02562
Capacitor, 6x653 Uf (circulation motor)	P02675
Extrusion (film clamp)	R01778
Fan Motor (circulation)4M105	P02646
Plastic Covers	SDC9
	SDC18
	SDC27
	SDC36