

Bed Extension

Safety, Operation, Maintenance & Parts Manual

BX6 for 2004+ Sawmills	Rev. A1.03
BX12 for 2004+ Sawmills	Rev. A1.03
BX24 for 2004+ Sawmills	Rev. A1.04



Safety is our #1 concern! Read and understand all safety information and instructions before operating, setting up or maintaining this machine.

April 2004

Form #295

Table of Contents

Section-Page

SECTION 1	SAFETY & GENERAL INFORMATION	1-1
1.1	Safety Symbols.....	1-1
1.2	Bed Extension Setup.....	1-2
1.3	Bed Extension Operation.....	1-3
1.4	Bed Extension Maintenance.....	1-4
SECTION 2	INSTALLATION	1-1
2.1	Alignment Box Installation	1-1
2.2	Leg Installation.....	1-3
2.3	Extension Frame Attachment	1-5
2.4	Support Brace Installation	1-8
2.5	Extra Leg and Bed Rail Installation (24-foot Bed Extensions Only).....	1-10
2.6	Hydraulic Log Handling Equipment Kits for MBX24 Bed Extensions.....	1-12
SECTION 3	BED EXTENSION ALIGNMENT	2-1
SECTION 4	LOG CLAMP OPERATION	3-1
SECTION 5	STORAGE PROTECTION	4-1

Table of Contents

Section-Page

SECTION 6	BED EXTENSION PARTS	5-1
6.1	BX24 Bed Extensions.....	5-1
6.2	Front & Rear Bed Rail Assembly (BX6 Only)	5-3
6.3	Front & Rear Bed Rail assembly (BX12 & BX24 Only).....	5-4
6.4	Front Middle Bed Rail Assembly (BX12 & BX24 Only)	5-5
6.5	Rear Middle Bed Rail Assembly (BX12 Only)	5-6
6.6	Pivot Bed Rail Assembly (BX24 Only)	5-7
6.7	Pivot Bed Rail Assembly (BX12 Only)	5-8
6.8	Accessory Bed Rail Assembly (BX24 Only).....	5-9
6.9	Log Clamp Mount Assembly (BX24).....	5-10
6.10	Manual Log Side Support.....	5-12
6.11	Mast Track Extension & Chain	5-14
6.12	Bed Extension Stationary Legs	5-16
6.13	Middle Stationary Legs (BX24 Only)	5-17
6.14	Fine Adjust Outrigger Leg.....	5-18
6.15	Side Fine Adjust Outrigger Leg	5-19
6.16	Manual Log Clamp (manual bed extension equipment: 24M)	5-20
6.17	Brace Assembly, SBX6.....	5-21
6.18	Brace Assembly, MBX6.....	5-22
6.19	LBX6 Connection Bracket	5-23
6.20	Brace Assembly, SBX12.....	5-24
6.21	Brace Assembly, MBX12.....	5-25
6.22	Brace Assembly, LBX12.....	5-26
6.23	Brace Assembly, SBX24.....	5-27
6.24	Brace Assembly, MBX24.....	5-28
6.25	Brace Assembly, LBX24.....	5-29
6.26	Brace Assembly, MBX24 Super	5-30
6.27	Bed Extension, MBX6 Super	5-31
6.28	Bed Extension, MBX12 Super	5-32
6.29	Oil Flow Divider w/Hydraulic Hoses (BX24 & "M" Frame)	5-33
6.30	Log Loader (Single Arm).....	5-34
SECTION 7	HYDRAULIC SYSTEM	6-1
7.1	Hydraulic Hose Hanger Kit, MBX24 Bed Extension (AH1-3)	6-1
7.2	Hydraulic Hose Hanger Kit, MBX24 Bed Extension (AH4-7).....	6-2
7.3	Hydraulic Hose Kit, BX24 Bed Extension	6-3
7.4	Hydraulic Control Box, 16-Section LT20/40/70 AC	6-6
7.5	Hydraulic Control Box, LT20/40/70 AC 10-Section	6-9

SECTION 1 SAFETY & GENERAL INFORMATION

1.1 Safety Symbols

The following symbols and signal words call your attention to instructions concerning your personal safety. Be sure to observe and follow these instructions.



The word **DANGER** indicates an imminently hazardous situation which, if not avoided, will result in death or serious injury.



WARNING suggests a potentially hazardous situation which, if not avoided, could result in death or serious injury.



CAUTION refers to potentially hazardous situations which, if not avoided, may result in minor or moderate injury to persons or equipment.



Warning stripes are placed on areas where a single decal would be insufficient. To avoid serious injury, keep out of the path of any equipment marked with warning stripes.

Read and observe all safety instructions before operating this equipment! Also read any additional manufacturer's manuals and observe any applicable safety instructions including dangers, warnings, and cautions.

Always be sure that all safety decals are clean and readable. Replace all damaged safety decals to prevent personal injury or damage to the equipment. Contact your local distributor, or call your Customer Service Representative to order more decals.

IMPORTANT! It is always the owner's responsibility to comply with all applicable federal, state and local laws, rules and regulations regarding the ownership, operation and towing of your Wood-Mizer sawmill. All Wood-Mizer mill owners are encouraged to become thoroughly familiar with these applicable laws and comply with them fully while using or towing the mill.

Always properly dispose of all sawing by-products, including sawdust and other debris, coolant, oil, fuel, oil filters and fuel filters.

1.2 Bed Extension Setup

WARNING! Securely fasten the legs of the bed extension to the ground before using the bed extension. Failure to do so will result in serious injury or death.

WARNING! Do not set up the mill on ground with more than a 10 degree incline. If setup on an incline is necessary, put blocks under one side of the mill or dig out areas for outrigger legs to keep mill level. Setting up the mill on an incline could cause it to tip over, resulting in serious personal injury.

1.3 Bed Extension Operation



IMPORTANT! This bed extension is designed and intended to work with the LT20, LT40 and LT70 series Wood-Mizer sawmills.

IMPORTANT! The operator should get adequate training in operation and adjustment of the sawmill.



DANGER! Make sure all guards and covers are in place and secured before operating or transporting the bed extension. Failure to do so may result in serious injury.

Be sure the blade housing and pulley covers are closed (i.e. the safety switches placed on these covers are engaged).

DANGER! Keep all persons out of the path of moving equipment and logs when operating the bed extension or loading and turning logs. Failure to do so may result in serious injury.

DANGER! Maintain a clean and clear path for all necessary movement around the mill and lumber stacking areas. Failure to do so may result in serious injury.

DANGER! Keep all persons out of the path of returning boards. Failure to do so may result in serious injury.



WARNING! Secure all loose clothing and jewellery before operating the sawmill. Failure to do so will result in serious injury or death.

WARNING! Always make sure log is clamped securely before sawing. Failure to do so will result in serious injury or death.

WARNING! Always leave loading arm halfway up while log is on sawmill bed. Failure to do so will result in serious injury or death.

WARNING! The automatic board return is intended to assist a second operator in removing boards quickly. Do not use the board return when operating the sawmill alone. Failure to do so will result in serious injury, death or damage to the equipment.

WARNING! Never use the board return table as a platform to stand on. This table is designed and intended to assist in the removal of boards only. Standing on the table may result in serious injury.



CAUTION! Be sure the pivot rails, turning arm, clamp, and toe boards are below bed level before loading a log onto the bed. Failure to do so may result in machine damage or cause misalignment.

CAUTION! Before loading a log, be sure the cutting head is moved far enough forward so the log does not hit it. Damage to the sawmill may result.

CAUTION! Be careful when manually lowering the log loader..Do not drop the loader onto the ground or perform any action which might break the velocity fuse valves on the loader cylinders.These valves control hydraulic flow and are necessary to prevent the loading arm from collapsing during use.

CAUTION! Do not try to force the saw head beyond its upper and lower travel limits. Damage to the up/down system may result.

CAUTION! Always make sure the up/down switch moves to the neutral or off position when released to ensure that the saw head stops moving. Damage to the sawmill may result.

CAUTION! Move the hydraulic clamp and turner to provide maximum ground clearance before transporting. Failure to do so may result in damage to the sawmill.

CAUTION! Be sure to stop the blade when returning the carriage. This will not only prevent the blade from being pulled off and ruined by a wood sliver, but also will increase the life of the blade.

1.4 Bed Extension Maintenance



CAUTION! Reinstall the track wiper so that it lightly touches the track rail. If the wiper presses too firmly against the rail, it can cause the power feed to bind.

CAUTION! Never use grease on the mast rails as it will collect sawdust.

CAUTION! Do not use chain lube. It causes sawdust buildup in chain links.

CAUTION! Do not overtension the chain. Damage to the feed motor may result.



CAUTION! Do not overtighten the set screws on the hydraulic valve assembly. Overtightening may cause the threads in the screw holes to strip.

CAUTION! Pressure should not exceed 2000 psi. Pressure above 2000 p.s.i. may damage the hydraulic hoses.

SECTION 2 INSTALLATION

The bed extension option includes a 6, 12 or 24-foot frame and the necessary hardware to attach it to your sawmill. After installation, the extension will allow you to cut longer logs than is possible with the standard sawmill. The bed extension is designed for operation with a stationary sawmill. A portable mill can be connected to the extension but will require 2 to 4 hours for each setup. The extension should be mounted to a firm, level footing. See [Form #359PL](#) located in the back of this manual for foot dimensions for each sawmill model and bed extension combination. Note the positions labeled A through E on each drawing. These positions will be referred to later for mounting the legs to the extension frame. Positions F, G, H and I apply to 24-foot extensions only.

2.1 Alignment Box Installation

1. Remove the feed chain from the tensioner bolt at the back end of the sawmill frame. Break apart the master link to disconnect the chain from the bolt.



CAUTION! When removing or replacing the feed chain on sawmills with hydraulic log handling, disconnect the negative battery lead. This will ensure the chain does not short the system if it contacts the power supply.

See Figure 2-1.

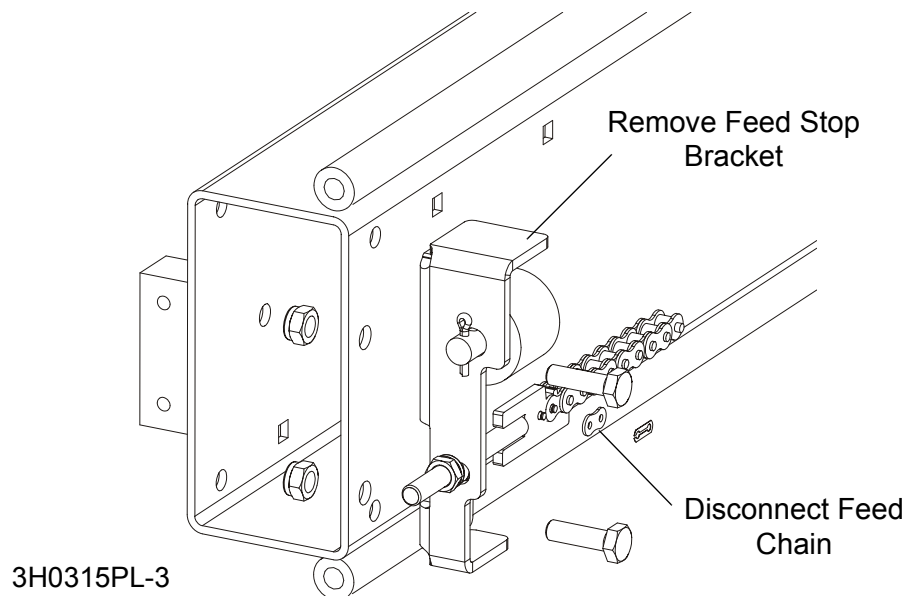

FIG. 2-1

2. Remove the bolts and lock nuts holding the feed chain tensioner to the sawmill frame. Remove the entire assembly from the sawmill frame. Use the same bolts and nuts to remount the tensioner assembly to the end of the extension frame.

3. Install the alignment link inside the end of the bed extension frame using the appropriate holes. Use four M10x115 hex head bolts and 10.5 flat washers to secure the box.

See Figure 2-2.

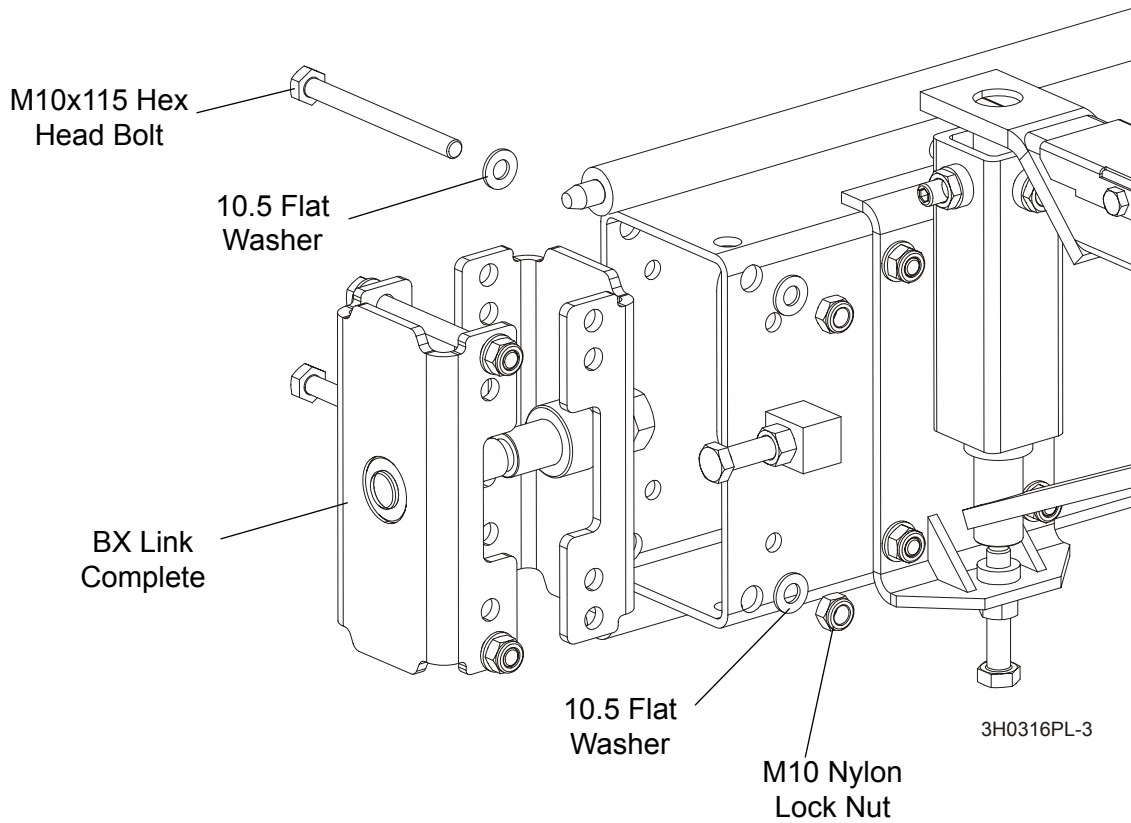

FIG. 2-2

2.2 Leg Installation

REMINDER: This section refers to positions A through E as labeled in [Form #359PL](#) located in the back of this manual.

1. Remove the rear leg (or outrigger) from position E on the sawmill frame. A support brace will be installed later that connects the extension frame to the sawmill frame. The removed sawmill leg will be repositioned on the support brace.

See Figure 2-3.

2. Use four M10 x 120 bolts and nylon lock nuts to secure a long leg at each position A and B on the extension frame. Insert the bolts from the outside of the frame tube and attach the nuts on the leg side of the tube.
3. **BX24 only:** Install a long leg at position H using four M10 x 25 bolts and nylon lock nuts.

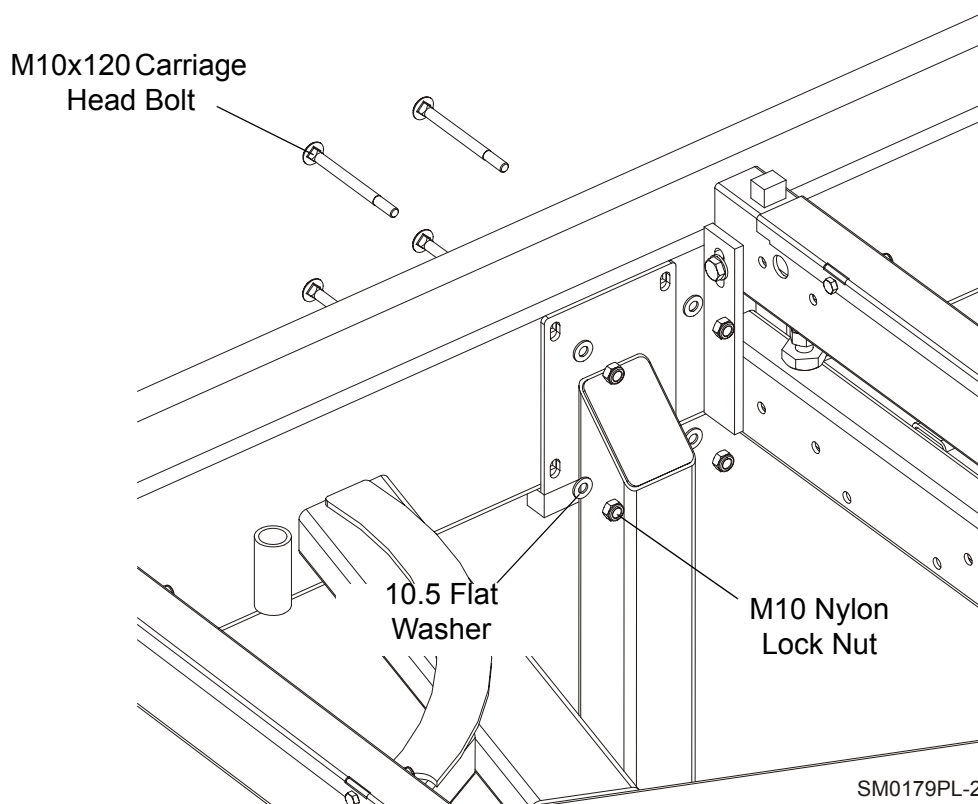

FIG. 2-3

4. Use four M10 x 25 bolts and nylon lock nuts to mount a short leg at position C on the extension frame.

See Figure 2-4.

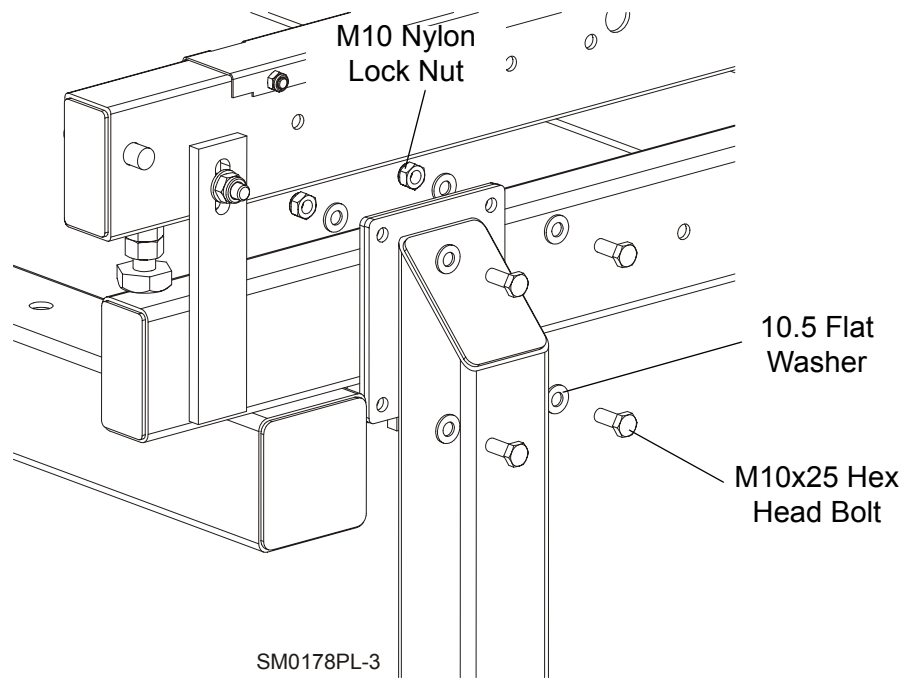

FIG. 2-4

2.3 Extension Frame Attachment

1. Position the extension frame at the end of the sawmill frame. Remove two bolts and nuts from the alignment link and loosen the jam nut. Turn the alignment link bolt counterclockwise to move the front plate towards as much as possible. Slide the extension frame over the alignment link on the sawmill frame. Sight down the length of the frames to see that they are lined up as close as possible.

See Figure 2-5.

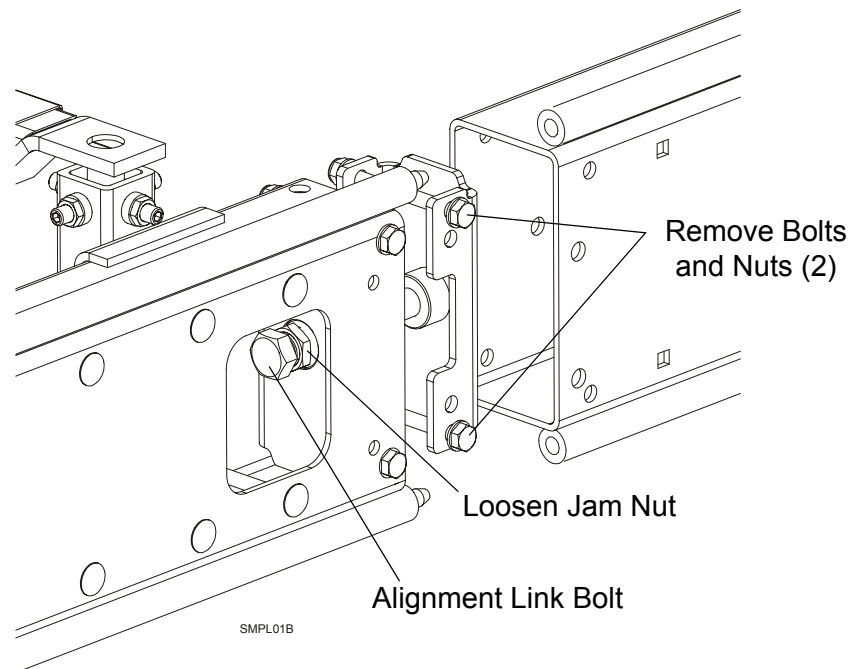

FIG. 2-5

2. Install two M10 X 115 hex head bolts in the holes together with four 10.5 flat washers. Secure the bolts with two M10-8 nylon lock hex nuts.

See Figure 2-6.

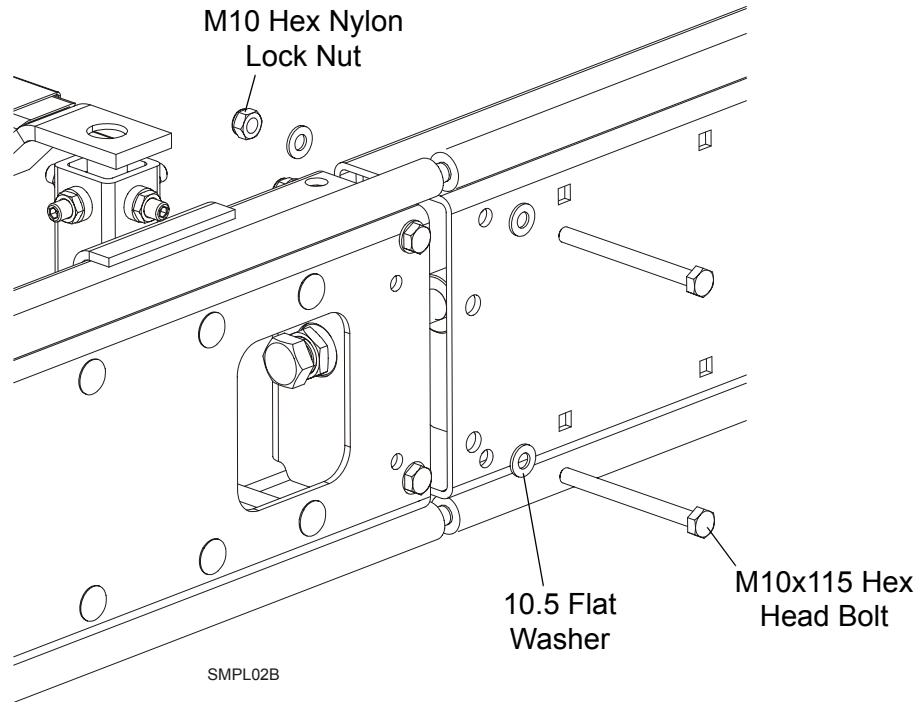

FIG. 2-6

3. Turn the alignment link bolt clockwise to tighten the bed extension and sawmill frame tubes.

See Figure 2-7.

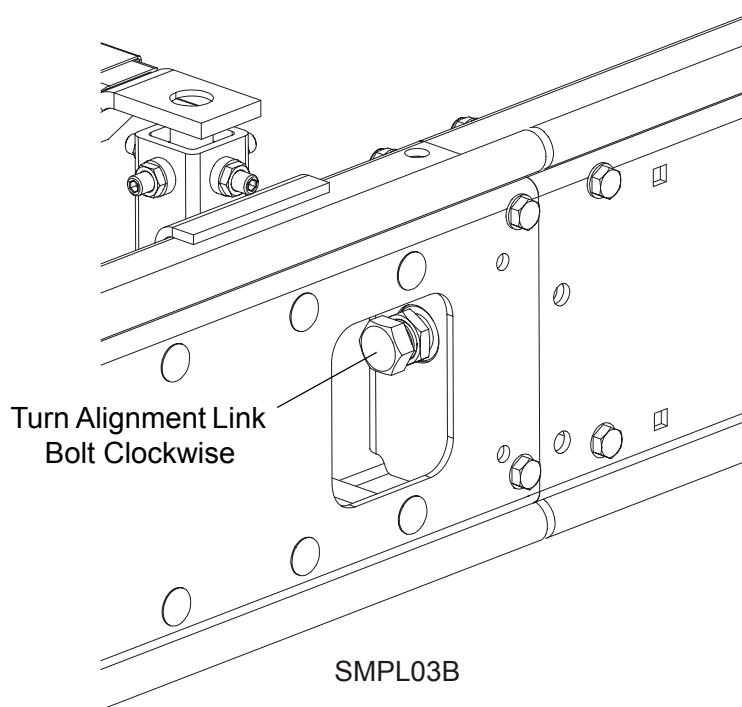

FIG. 2-7

4. Be sure to tighten the alignment link jam nut against the box when the attachment procedure is complete.

2.4 Support Brace Installation

See **Table. 2-1**. A support brace is available to connect the bed extension and the sawmill. See the chart below to determine which brace you need for your configuration.

Bed Extension Support Brace Reference Table		
Sawmill Model	Bed-X	Brace Kit
1996+ LT30 or LT30HD	1996+ BX6	085651-1, 085653-1
	1996+ BX12	014271
	1996+ BX24	014273
1996+ LT40 or LT40HD	1996+ BX6	085651-1, 085656-1
	1996+ BX12	014270
	1996+ BX24	014272

TABLE. 2-1

1. Mount the support brace tube between the sawmill and extension frames at positions D and E. Use four M10 x 25 bolts and lock nuts to secure the brace at position D and E.

See **Figure 2-8**.

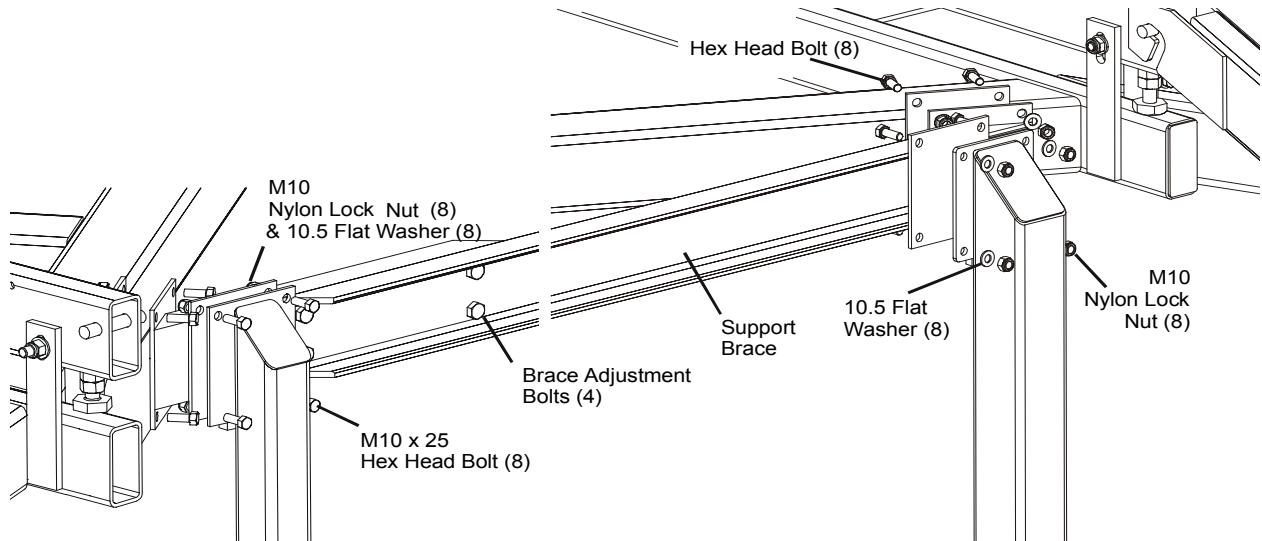

FIG. 2-8

2. Bolt the leg previously removed from the sawmill and a supplied short leg to the support brace tube with four M10 x 25 bolts and nylon lock nuts each.
3. Attach the supplied length of feed chain to the existing feed chain with the master link provided. Connect the feed chain to the tensioner bolt at the end of the extension frame. Adjust the tensioner so that the chain is positioned as indicated below. Make sure the feed chain is not twisted or kinked

See Table. 2-2. .

BX Model	Distance from top of top track rail to top of feed chain (measure at middle of chain span)
BX6	7 - 8 inches
BX12	8 - 9 inches
BX24	10 - 11 inches

TABLE. 2-2

2.5 Extra Leg and Bed Rail Installation (24-foot Bed Extensions Only)

1. The additional long leg should be mounted at position F shown in [Form #359PL](#). Use M10 x 120 bolts and lock nuts to secure the long leg to the main frame tube.

NOTE: When bolting near the end of the main tube, the tube can collapse or "mushroom" as the bolts are tightened. Do not overtighten the bolts to avoid deforming the main tube. If you find it difficult to align the tracks with the alignment set screws, check that neither frame tube is deformed. The tube can be pulled back into shape using the alignment set screws.

See Figure 2-9.

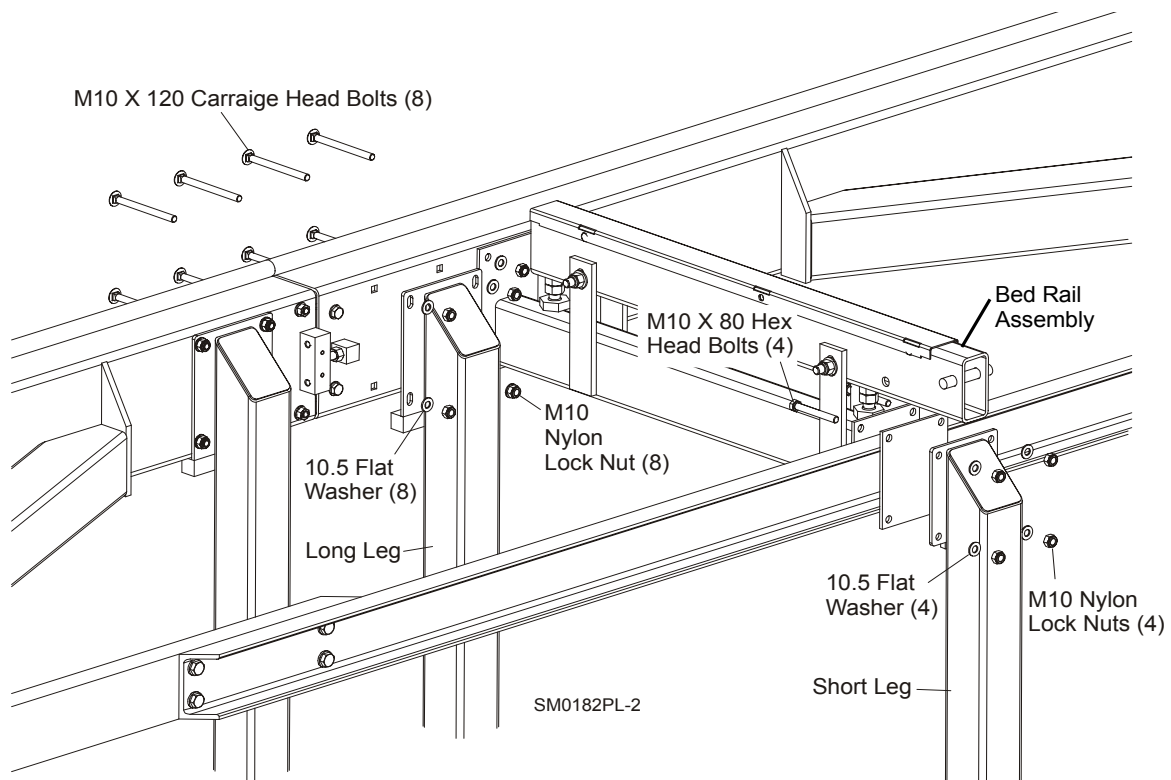

FIG. 2-9

2. Mount the additional bed rail assembly and short leg at position G on the support brace tube. Use bolts and lock nuts to mount the short leg and bed rail to the support brace tube. Use M10 x 120 bolts and lock nuts to mount the other end of the bed rail to the main tube.

2

Installation

Extra Leg and Bed Rail Installation (24-foot Bed Extensions Only)

3. Mount two middle short legs at position I shown in [Form #359PL](#). Use four M12 X 30 hex head bolts.

See Figure 2-10.

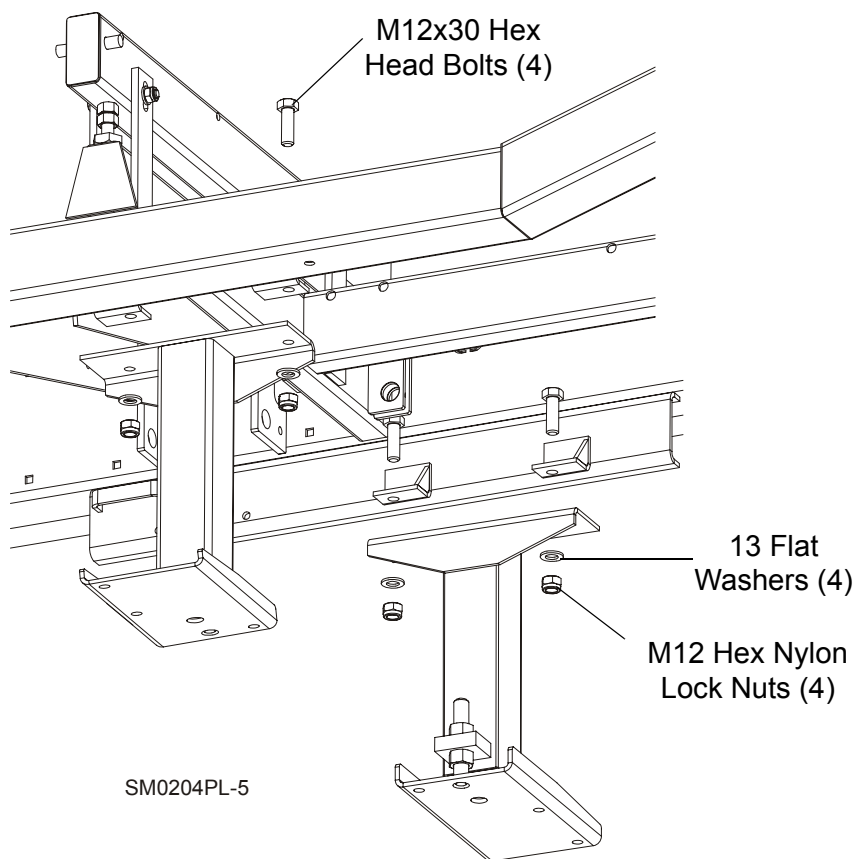

FIG. 2-10

2.6 Hydraulic Log Handling Equipment Kits for MBX24 Bed Extensions

See Table 2-3.

Log Handling Function/Kit Symbol	24M	24H1	24H2	24H3	24H4	24H5	24H6
Manual Side Supports	◆ (3)						
Manual Clamp	◆						
Hydraulic Side Supports		◆ (3)	◆ (3)	◆ (3)	◆ (3)	◆ (3)	◆ (3)
Toe Board Roller			◆	◆	◆	◆	◆ (2)
Middle Clamp				◆	◆	◆	◆
Log Turner					◆	◆	◆
Pull-Down Clamp						◆	◆
Log Deck	◆						

TABLE 2-3

SECTION 3 BED EXTENSION ALIGNMENT

1. Use the six set screws around the extension frame tube to align the upper and lower tracks on the sawmill to the tracks on the extension. You should not be able to detect any variance where one track ends and the other starts.
2. Move the cutting head across the area where the sawmill frame and extension meet. If the tracks are properly aligned, you should not be able to tell when the track bearings cross from the sawmill to the extension. Any variance will cause inaccurately sawn boards! Fine tune the set screws until the sawmill and extension tracks are perfectly matched.

NOTE: Bolting through the main tube can cause the tube to collapse or "mushroom". If you find it difficult to align the tracks with the alignment set screws, check that neither frame tube is deformed. The tube can be pulled back into shape using the alignment set screws.

3. Place two equal height objects on top of the track rail (wrench sockets work well). Pull a string tight over the objects and clamp so there is no sag in the string. Measure from the string to the track at one end, the middle, and the other end of the track. The track should be 1/16 to 1/8" (1.5 to 3.0 mm) higher in the middle than at the ends. This will compensate for any sag that occurs as the cutting head reaches the middle of the track. If more bow in the middle is needed, shim the middle track-mounted legs. If the middle is bowed up too much, shim the track-mounted legs at each end of the frame. Shim under any feet that do not touch the ground.
4. Align the sawmill and extension as instructed in your sawmill manual.

SECTION 4 LOG CLAMP OPERATION

A manual log clamp is supplied with the bed extension to help clamp long logs against the side supports.

1. Insert the log clamp post in the slotted channel between the middle bed rails of the extension. Choose a hole close to the log.
2. Pull the clamp handle to spin the cam against the log and clamp the log firmly against the side supports.
3. Lock the clamp in place with the chain mounted to the extension frame. Stretch the chain up to the clamp and slip the chain through the slot on the clamp handle. Use a link in the chain that holds the clamp firmly against the log.

SECTION 5 STORAGE PROTECTION

When not using the bed extension, follow the recommendations below to prevent rust and/or corrosion.

1. Coat the top and bottom bed extension rails with a rust inhibitor such as Sherwin-Williams P.D.R.P. #710.
2. Coat the power feed chain with a light film of a light-weight lubricant such as Dexron III ATF. Make sure the connecting link is attached to the chain to prevent chain loss.
3. Coat the threads of the bed rail leveling bolts with a dry lube such as Gunk L-508.
4. Lubricate the pivot block/shaft on the pivot bed rails with NLGI No. 2 grade lithium grease such as Amoco Rycon #2 Synthetic Grease.

Preparation For Use

Before using a bed extension that has been stored in the above manner, remove the rust inhibitor protection coat from the bed extension rails. Use a clean, dry cloth and a light lubricant such as WD-40 to remove the protection coat.

SECTION 6 BED EXTENSION PARTS

6.1 BX24 Bed Extensions

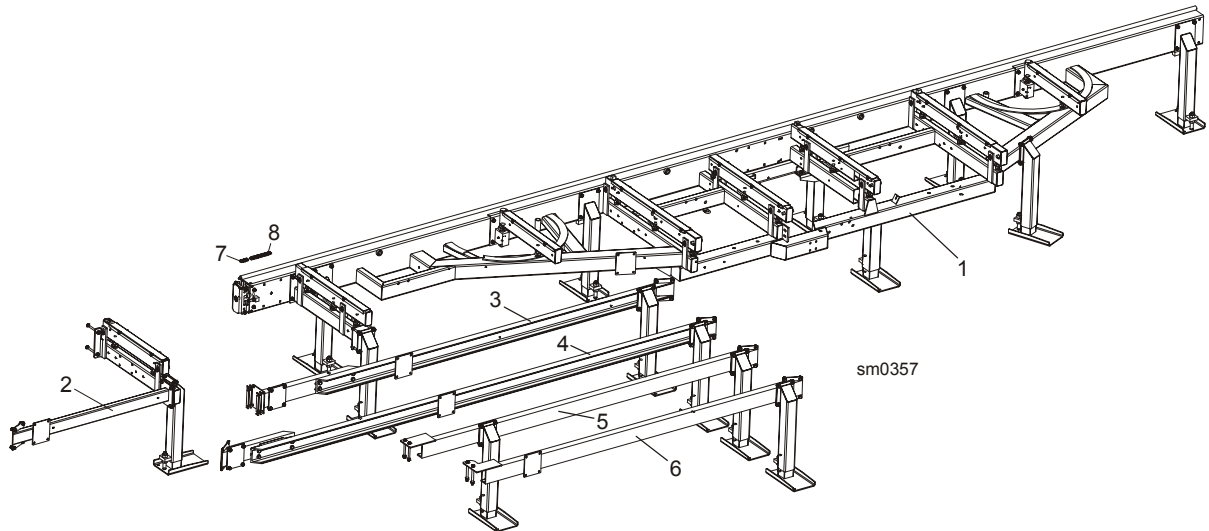

REF.	DESCRIPTION (◆ Indicates Parts Available In Assemblies Only)	PART #	QTY.
LT20			
BX24 BED EXTENSIONS FOR LT20S SAWMILLS		505816	1
1	FRAME, BX24 COMPLETE	505716	1
4	BRACE ASSEMBLY, SBX24 See Section 6.23	093931	1
BX24 BED EXTENSIONS FOR LT20 M AH1-3 SAWMILLS		505817	1
1	FRAME, BX24 COMPLETE	505716	1
2	REAR COMPLETE LOG CLAMP MOUNT (STATIONARY SAWMILLS) See Section 6.9	092938	1
3	BRACE ASSEMBLY, MBX24-AH5/7 DH5/7 See Section 6.24	095632	1
BX24 BED EXTENSIONS FOR LT20 M AH4-7 SAWMILLS		505818	1
1	FRAME, BX24 COMPLETE	505716	1
3	BRACE ASSEMBLY, MBX24-AH5/7 DH5/7 See Section 6.24	095632	1
BX24 BED EXTENSIONS FOR LT20 L SAWMILLS		505820	1
1	FRAME, BX24 COMPLETE	505716	1
6	BRACE ASSEMBLY, LBX24 See Section 6.25	501661	1
LT40			
BX24 BED EXTENSIONS FOR LT40 S SAWMILLS		505821	1
1	FRAME, BX24 COMPLETE	505716	1
4	BRACE ASSEMBLY, SBX24 See Section 6.23	093931	1
7	LINK, #40 MASTER	P04200	1
8	CHAIN, #40 286 1/2	P11909	1
BX24 BED EXTENSIONS FOR LT40 M AH1-3 SAWMILLS		505822	1
1	FRAME, BX24 COMPLETE	505716	1
2	REAR COMPLETE LOG CLAMP MOUNT (STATIONARY SAWMILLS) See Section 6.9	092938	1

3	BRACE ASSEMBLY, MBX24-AH5/7 DH5/7 See Section 6.24	095632	1	
7	LINK, #40 MASTER	P04200	1	
8	CHAIN, #40 286 1/2	P11909	1	
	BX24 BED EXTENSIONS FOR LT40 M AH4-7 SAWMILLS	505823	1	
1	FRAME, BX24 COMPLETE	505716	1	
3	BRACE ASSEMBLY, MBX24-AH5/7 DH5/7 See Section 6.24	095632	1	
7	LINK, #40 MASTER	P04200	1	
8	CHAIN, #40 286 1/2	P11909	1	
	BX24 BED EXTENSIONS FOR LT40 M SUPER SAWMILLS	505824	1	
1	FRAME, BX24 COMPLETE	505716	1	
5	BRACE ASSEMBLY, MBX24 SUPER See Section 6.26	099197	1	
7	LINK, #40 MASTER	P04200	1	
8	CHAIN, #40 286 1/2	P11909	1	
	BX24 BED EXTENSIONS FOR LT40 L SAWMILLS	505825	1	
1	FRAME, BX24 COMPLETE	505716	1	
6	BRACE ASSEMBLY, LBX24 See Section 6.25	501661	1	
7	LINK, #40 MASTER	P04200	1	
8	CHAIN, #40 286 1/2	P11909	1	
	LT70			
	BX24 BED EXTENSIONS FOR LT70 S SAWMILLS	505826	1	
1	FRAME, BX24 COMPLETE	505716	1	
4	BRACE ASSEMBLY, SBX24 See Section 6.23	093931	1	
7	LINK, #40 MASTER	P04200	1	
8	CHAIN, #40 286 1/2	P11909	1	
	BX24 BED EXTENSIONS FOR LT70 M AH1-3 SAWMILLS	505827	1	
1	FRAME, BX24 COMPLETE	505716	1	
2	REAR COMPLETE LOG CLAMP MOUNT (STATIONARY SAWMILLS) See Section 6.9	092938	1	
3	BRACE ASSEMBLY, MBX24-AH5/7 DH5/7 See Section 6.24	095632	1	
7	LINK, #40 MASTER	P04200	1	
8	CHAIN, #40 286 1/2	P11909	1	
	BX24 BED EXTENSIONS FOR LT70 M AH4-7 SAWMILLS	505828	1	
1	FRAME, BX24 COMPLETE	505716	1	
3	BRACE ASSEMBLY, MBX24-AH5/7 DH5/7 See Section 6.24	095632	1	
7	LINK, #40 MASTER	P04200	1	
8	CHAIN, #40 286 1/2	P11909	1	
	BX24 BED EXTENSIONS FOR LT70 M SUPER SAWMILLS	505829	1	
1	FRAME, BX24 COMPLETE	505716	1	
5	BRACE ASSEMBLY, MBX24 SUPER See Section 6.26	099197	1	
7	LINK, #40 MASTER	P04200	1	
8	CHAIN, #40 286 1/2	P11909	1	
	BX24 BED EXTENSIONS FOR LT70 L SAWMILLS	505830	1	
1	FRAME, BX24 COMPLETE	505716	1	
6	BRACE ASSEMBLY, LBX24 See Section 6.25	501661	1	
7	LINK, #40 MASTER	P04200	1	
8	CHAIN, #40 286 1/2	P11909	1	

6.2 Front & Rear Bed Rail Assembly (BX6 Only)

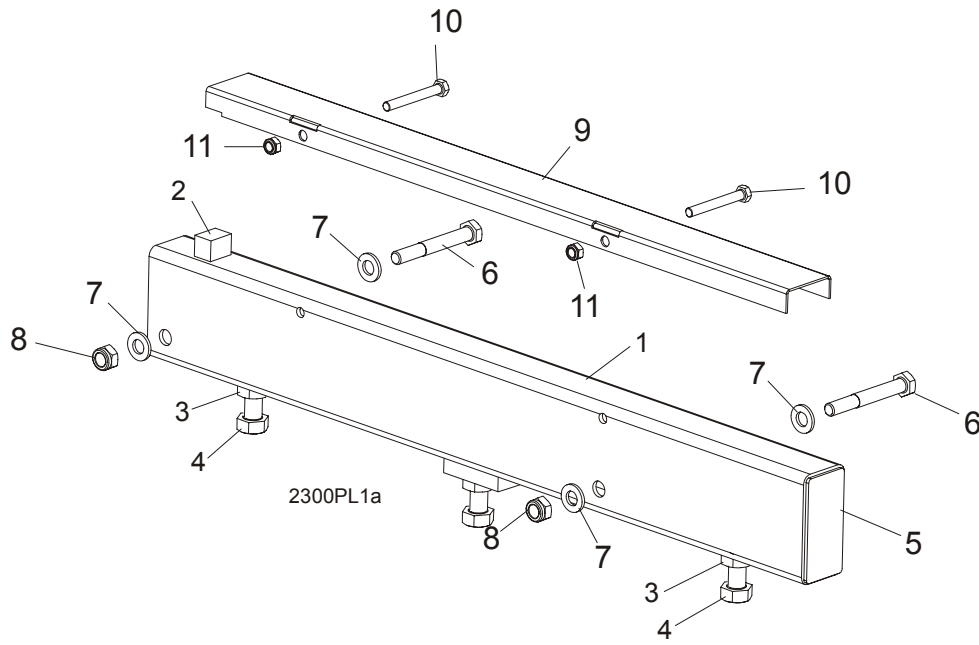

REF.	DESCRIPTION (◆ Indicates Parts Available In Assemblies Only)	PART #	QTY.	
	REAR BED RAIL ASSEMBLY	A09774	2	
1	Tube, BX6/24 Frame Bed Rail	085469	1	◆
2	Block, 3/4 X 3/4 X 1	S09034	1	
	Bolt Assembly, Bed Rail Adjustment	A09775	2	◆
3	Nut, M16-5.8 Hex Zinc	F81036-1	4	
4	Bolt, M16x65-8.8 Hex Head Full Thread Zinc	F81006-1	2	
5	Plate, Bed Rail Cap	S04058	1	
6	BOLT, M12 X 90-8.8 HEX HEAD ZINC	F81004-2	4	
7	WASHER, 13 FLAT ZINC	F81056-1	8	
8	NUT, M12-8 HEX NYLON ZINC LOCK	F81034-2	4	
	COVER ASSEMBLY, BED RAIL STAINLESS STEEL (LONG)	A09956	2	
9	Cover, BX6 Stainless Steel Bed Rail	085464	1	
10	Bolt, M8 x 65-5.8 Hex Head Zinc	F81002-3	2	
11	Nut, M8-8-B Hex Nylon Zinc Lock	F81032-2	2	

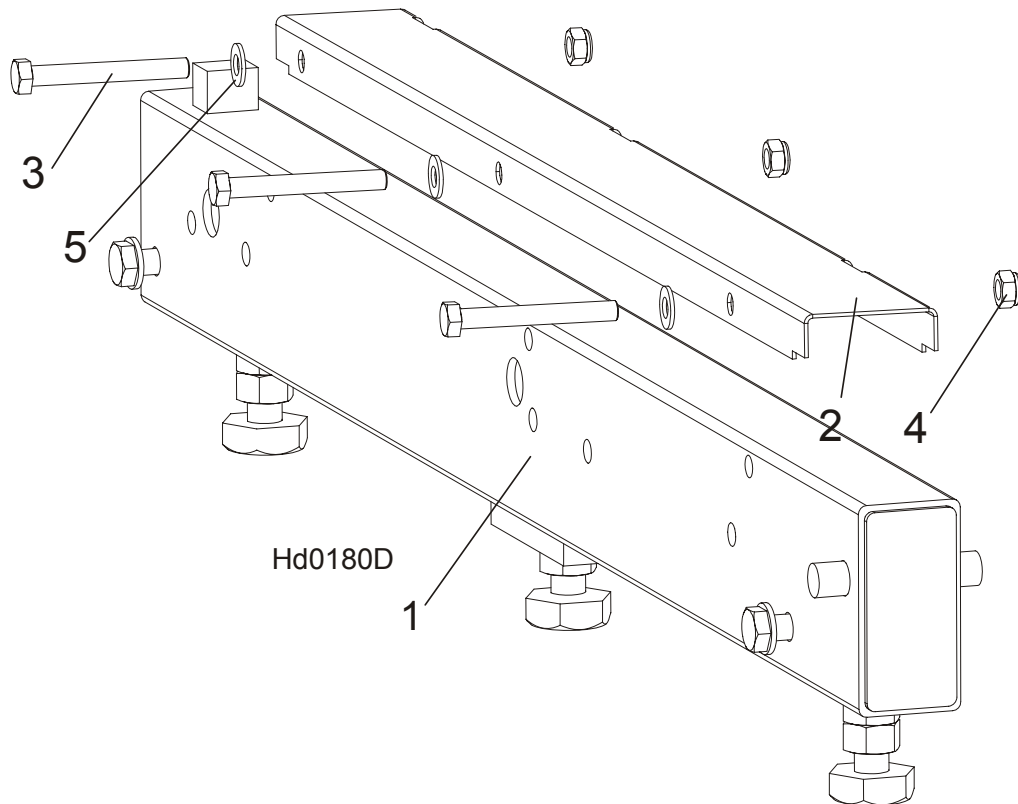
6.3 Front & Rear Bed Rail Assembly (BX12 & BX24 Only)

REF.	DESCRIPTION (◆ Indicates Parts Available In Assemblies Only)	PART #	QTY.
1	FRONT & REAR BED RAIL ASSEMBLY	091555	2
2	COVER, STAINLESS STEEL BED RAIL	099124	2
3	BOLT, M8X65-5.8 HEX HEAD ZINC	F81002-3	6
4	NUT, M8-8-B HEX NYLON ZINC LOCK	F81032-2	6
5	WASHER, 8.4 FLAT ZINC	F81054-1	6

6.4 Front Middle Bed Rail Assembly (BX12 & BX24 Only)

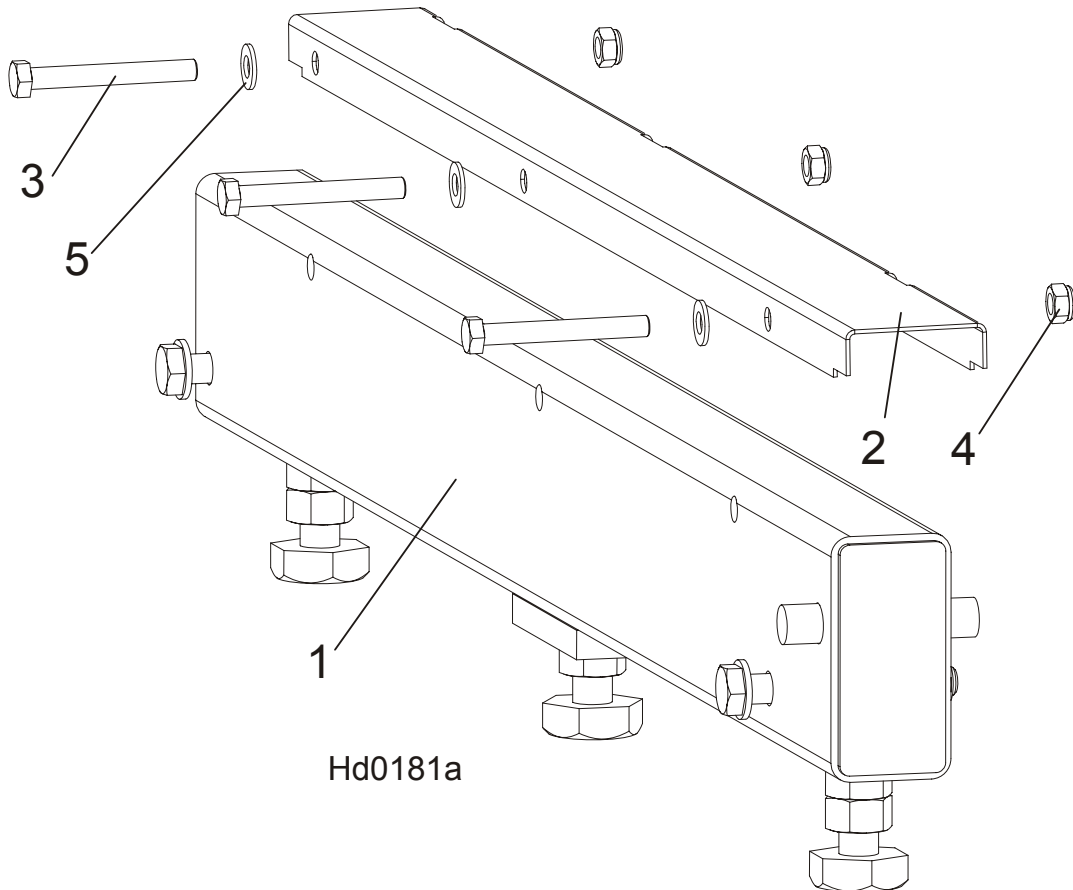

REF.	DESCRIPTION (◆ Indicates Parts Available In Assemblies Only)	PART #	QTY.
1	TUBE, BED RAIL	091556	1
2	COVER, STAINLESS STEEL BED RAIL	099124	1
3	BOLT, M8X65-5.8 HEX HEAD ZINC	F81002-3	3
4	NUT, M8-8-B HEX NYLON ZINC LOCK	F81032-2	3
5	WASHER, 8.4 FLAT ZINC	F81054-1	3

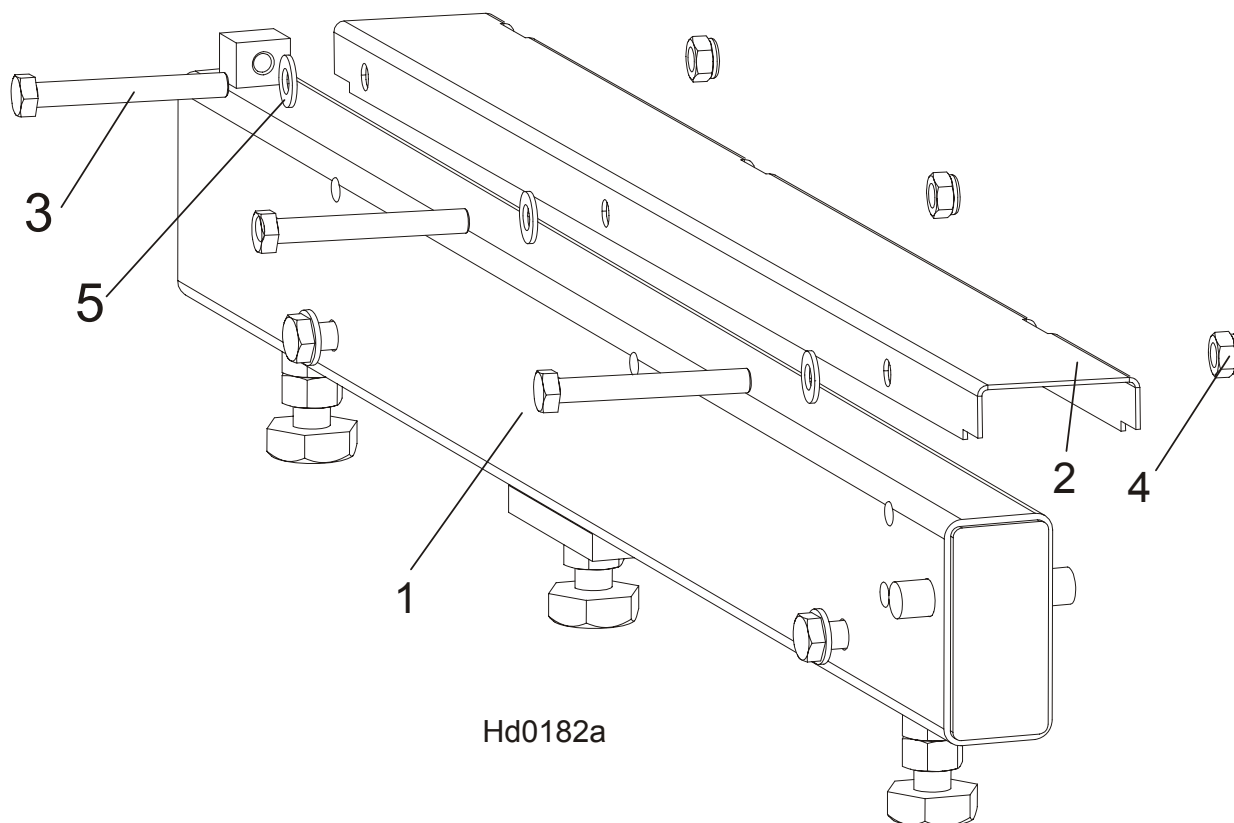
6.5 Rear Middle Bed Rail Assembly (BX12 Only)

REF.	DESCRIPTION (◆ Indicates Parts Available In Assemblies Only)	PART #	QTY.
1	TUBE, BED RAIL	091557	1
2	COVER, STAINLESS STEEL BED RAIL	099124	1
3	BOLT, M8X65-5.8 HEX HEAD ZINC	F81002-3	3
4	NUT, M8-8-B HEX NYLON ZINC LOCK	F81032-2	3
5	WASHER, 8.4 FLAT ZINC	F81054-1	3

6.6 Pivot Bed Rail Assembly (BX24 Only)

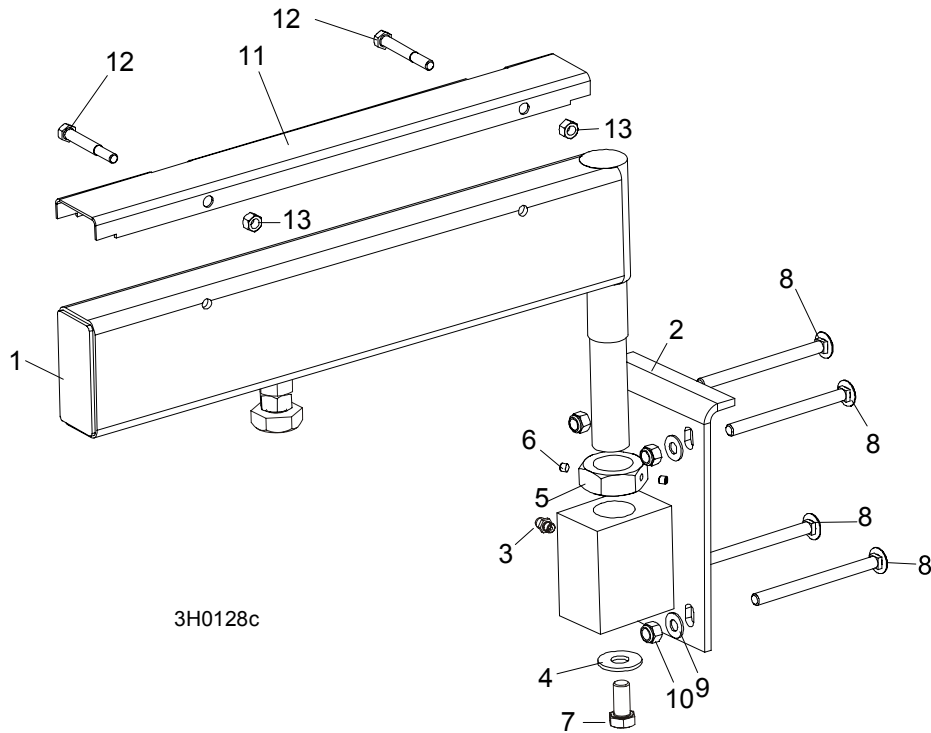

REF.	DESCRIPTION (◆ Indicates Parts Available In Assemblies Only)	PART #	QTY.	
	PIVOT BED RAIL ASSEMBLY	087855	2	
1	Pivot Bed Rail	087848-1	1	◆
2	Bracket Weldment, Pivot Rail Mount	087841-1	1	
3	Fitting, M6 Type A Straight Grease	086280	1	
4	Washer, 9/16" Flat Zinc	F05011-52	1	
5	Nut, M32 Pivot Rail Adjustment	F81039-2	1	
6	Screw, 1/4-28x1/4 SH Brass Tip Set	F05005-42	2	
7	Bolt, M12x25-8.8 Hex Head Full Thread Zinc	F81004-31	1	
8	BOLT, M10 X 120 8.8 CARRIAGE HEAD ZINC	F81003-33	8	
9	WASHER, 10.5 FLAT ZINC	F81055-1	8	
10	NUT, M10-8-B HEX NYLON ZINC LOCK	F81033-1	8	
11	COVER, STAINLESS STEEL	099123	2	
12	BOLT, M8 X 65-5.8 HEX HEAD ZINC	F81002-3	4	
13	NUT, M8-8-B HEX NYLON ZINC LOCK	F81032-2	4	

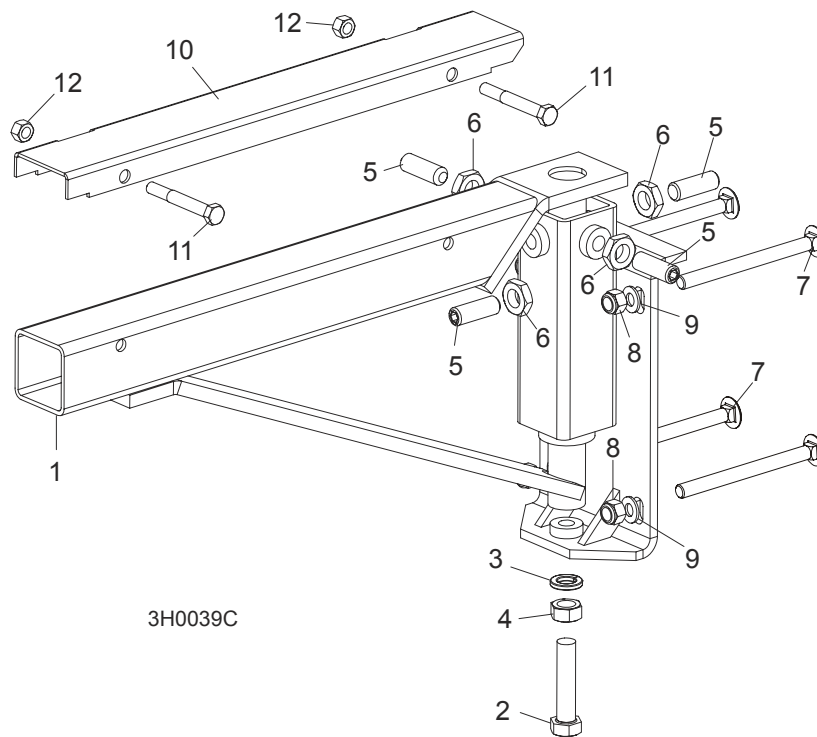
6.7 Pivot Bed Rail Assembly (BX12 Only)

REF.	DESCRIPTION (◆ Indicates Parts Available In Assemblies Only)	PART #	QTY.
	PIVOT BED RAIL ASSEMBLY	093906	1
1	Rail Weldment, Pivot	093907-1	1
2	Bolt, M12x1.25x65-8.8 Hex Head Full Thread Zinc	F81004-40	1
3	Washer, Z12.2 Split Lock Zinc	F81056-2	1
4	Nut, M12x1.25-8 Hex Zinc	F81034-8	1
5	Screw, M12x1.25x30 DIN913 Set Stainless Steel	F81016-1	4
6	Nut, M12x1,25 DIN439 Thin Stainless Steel	F81034-9	4
7	Bolt, M10x120 8.8 Carriage Head Zinc	F81003-33	4
8	Nut, M10-8-B Hex Nylon Zinc Lock	F81033-1	4
9	Washer, 10.5 Flat Zinc	F81055-1	4
10	Cover, Pivot Bed Rail	093962	1
11	Bolt, M8x65-5.8 Hex Head Zinc	F81002-3	2
12	Nut, M8-8-B Hex Nylon Zinc Lock	F81032-2	2

6.8 Accessory Bed Rail Assembly (BX24 Only)

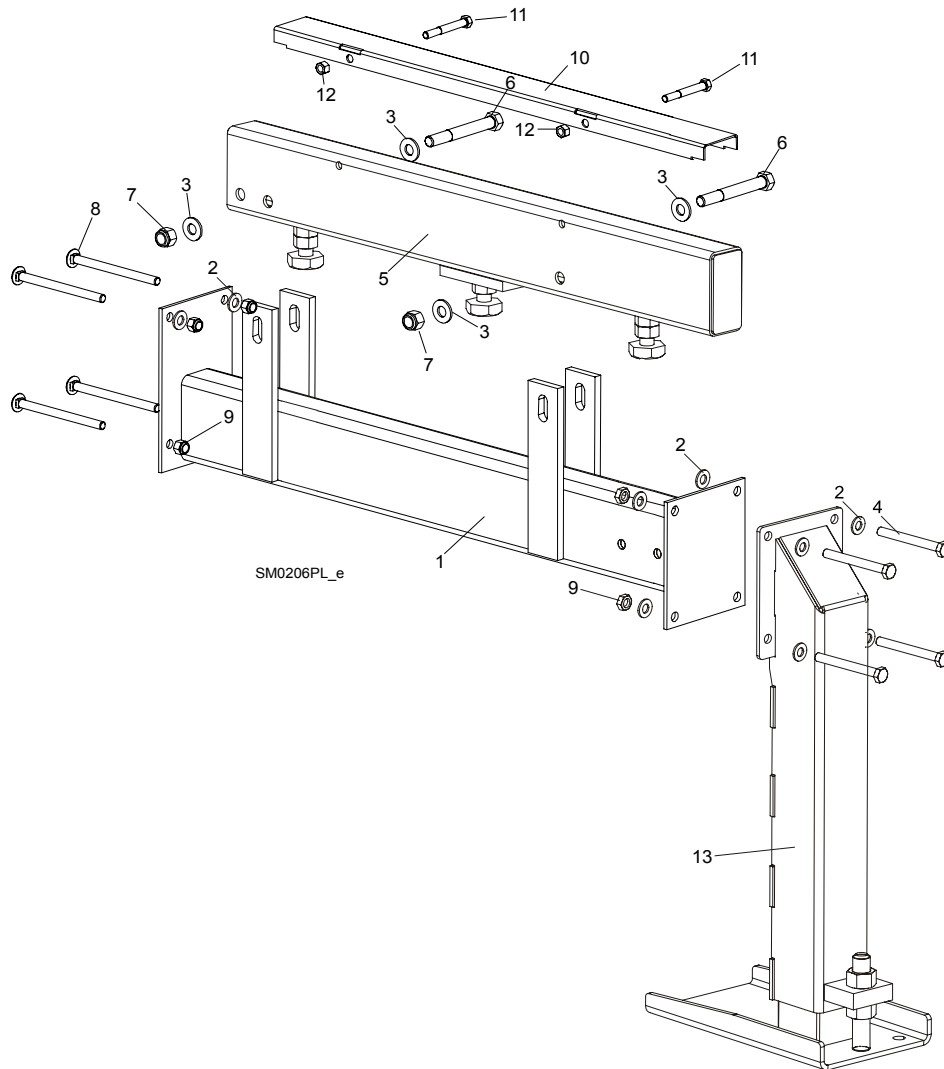

REF.	DESCRIPTION (◆ Indicates Parts Available In Assemblies Only)	PART #	QTY.
	RAIL ASSEMBLY, BX24	093175	1
1	Mount Weldment, BX24 Rail Ptd	093176-1	1
2	WASHER, 10.5 FLAT ZINC	F81055-1	12
3	Washer, 13 Flat Zinc	F81056-1	4
4	BOLT M10X80-8.8-PN/M-82101 FE/ZN5	F81003-51	4
5	Rail Weldment, BX24 Ptd	093180-1	1
6	Bolt, M12x90-8.8 Hex Head Zinc	F81004-2	2
7	Nut, M12-8 Hex Nylon Zinc Lock	F81034-2	2
8	Bolt, M10x120 8.8 Carriage Head Zinc	F81003-33	4
9	Nut, M10-8-B Hex Nylon Zinc Lock	F81033-1	8
10	Cover, BX6 Rail Short	085464	1
11	Bolt, M8x65-5.8 Hex Head Zinc	F81002-3	2
12	Nut, M8-8-B hex nylon zinc lock	F81032-2	2
13	LEG, LEFT ADJUSTABLE STATIONARY	501639	1

6.9 Log Clamp Mount Assembly (BX24)

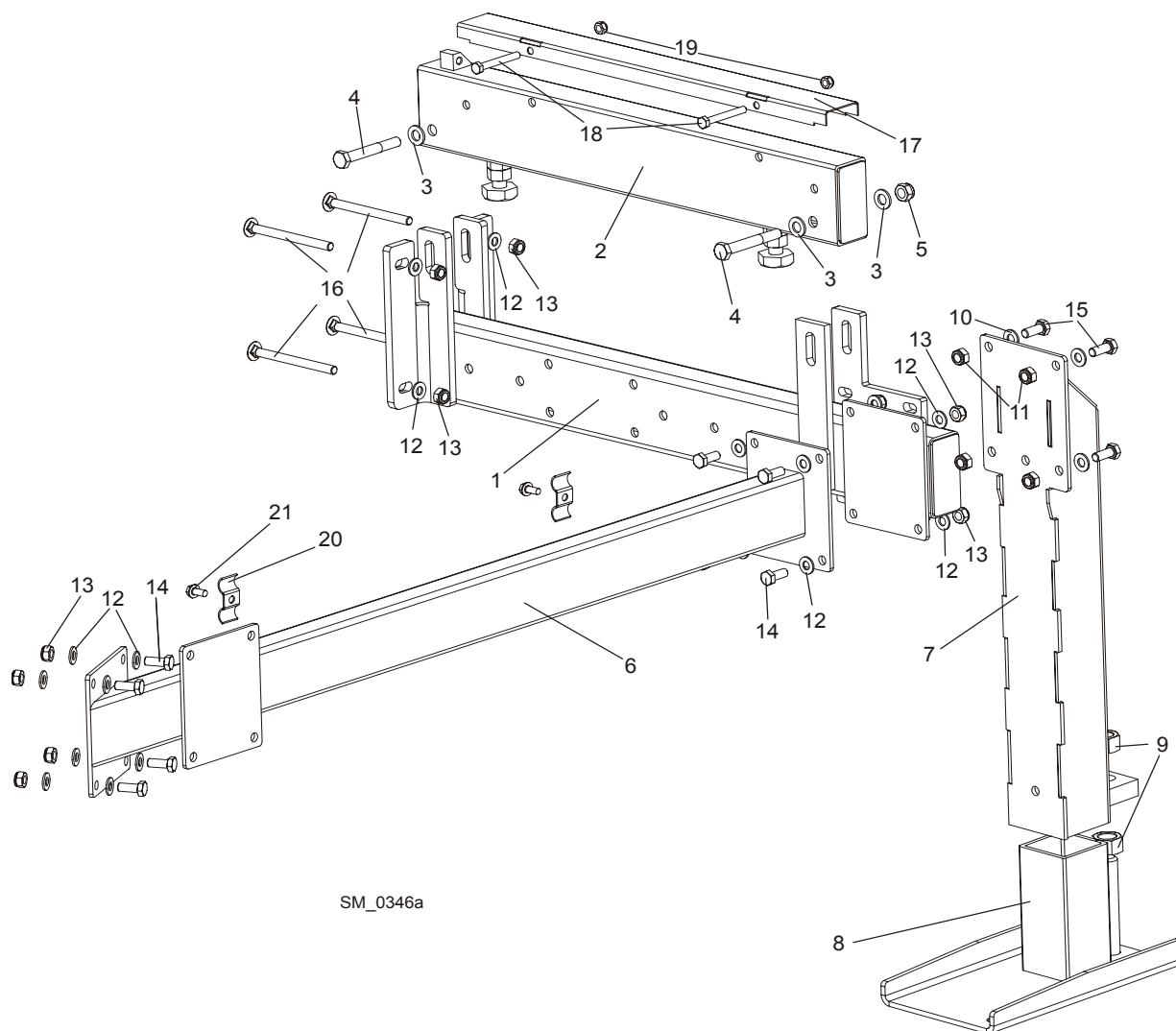

SM_0346a

REF.	DESCRIPTION (◆ Indicates Parts Available In Assemblies Only)	PART #	QTY.
	REAR COMPLETE LOG CLAMP MOUNT (STATIONARY SAWMILLS)	092938	1
1	PODPORA ŁOŻA DOCISKU KŁODY-TYLNATUBE WELDMENT, REAR CLAMP MOUNT	092902-1	1
2	TUBE, AH/DH4-7 BED RAIL	095131-1	1
3	WASHER, 13 FLAT ZINC	F81056-1	4
4	BOLT, M12x90-8.8 HEX HEAD ZINC	F81004-2	2
5	NUT, M12-8 HEX NYLON ZINC LOCK	F81034-2	2
6	BRACE, REAR	092907-1	1
	LEG, LEFT ADJUSTABLE STATIONARY	501639	1
7	LEG WELDMENT - UPPER PART	507715-1	1
8	WIDE FOOT - ADJUSTABLE LEGS	501084-1	1
9	NUT, M20-8 HEX ZINC	F81037-1	2
10	WASHER, 10.5 FLAT ZINC	F81055-1	4
11	NUT, M10-8-B HEX NYLON ZINC LOCK	F81033-1	4

BED EXTENSION PARTS
Log Clamp Mount Assembly (BX24)

6

12	WASHER, 10.5 FLAT ZINC	F81055-1	24	
13	NUT, M10-8-B HEX NYLON ZINC LOCK	F81033-1	12	
14	BOLT, M10x25-8.8 HEX HEAD FULL THREAD ZINC	F81003-11	8	
15	BOLT, M10x35-8.8 HEX HEAD FULL THREAD ZINC	F81003-17	4	
16	BOLT, M10x125 8.8 CARRIAGE HEAD ZINC	F81003-34	4	
17	COVER, PIVOT BED RAIL	099123	1	
18	BOLT, M8x65-5.8 HEX HEAD ZINC	F81002-3	2	
19	NUT, M8-8-B HEX NYLON ZINC LOCK	F81032-2	2	
20	PLATE, 1/4" HOSE CLAMP	S09245	2	
21	SCREW, 5/16-18 x 3/4 SELF-TAPPING	F05015-30	2	

6.10 Manual Log Side Support

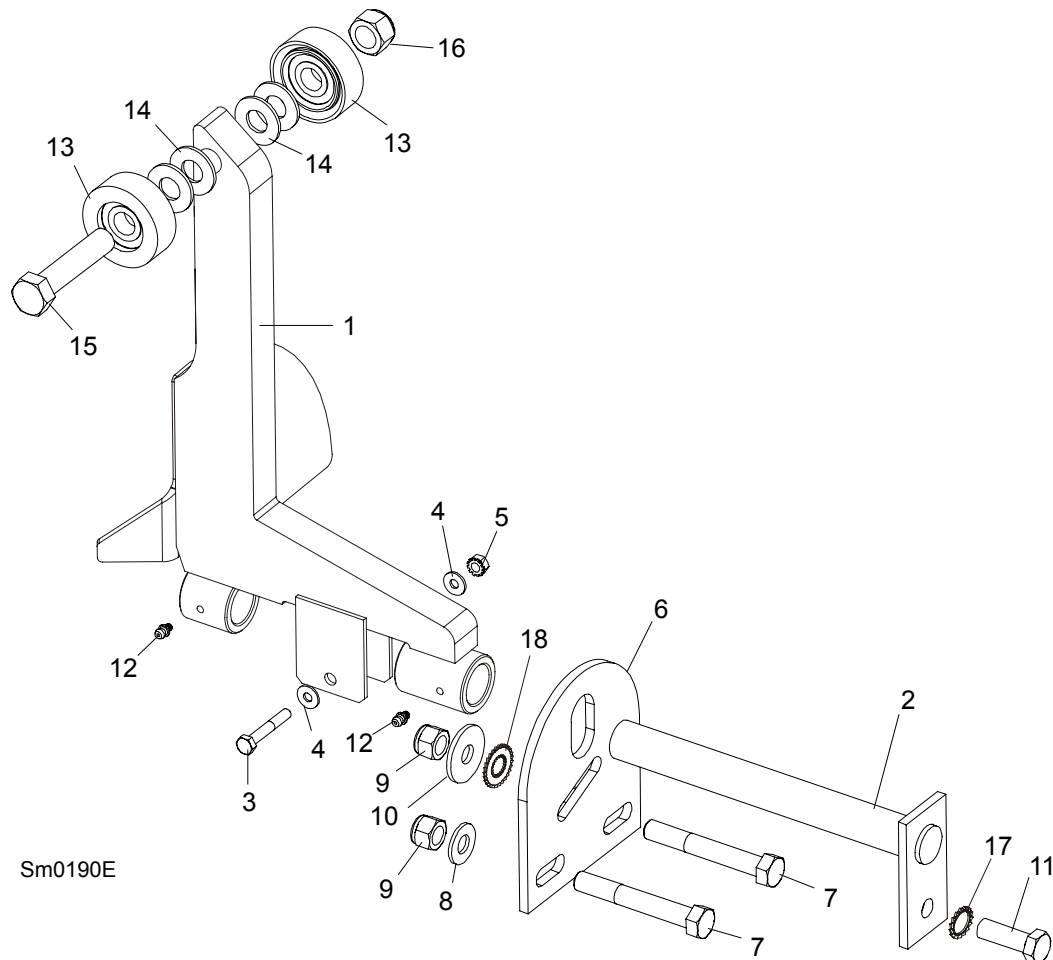

Sm0190E

REF.	DESCRIPTION (◆ Indicates Parts Available In Assemblies Only)	PART #	QTY.
	MANUAL LOG SIDE SUPPORT ASSEMBLY (FOR BX6)	500960	1
1	Support, Log Side w/Guard Ptd	099785-1	1
	Mount Kit, Side Support	K09440	1
2	Pin, Log Side Support Zinc-plated	091549-1	1
3	Bolt, M8x45- 8.8 Hex Head Full Thread Zinc	F81002-14	1
4	Washer, 13 Flat Zinc	F81056-1	2
5	Nut, M8-8-B Hex Nylon Zinc Lock	F81032-2	1
6	Plate, Log Side Support Mount Ptd	091591-1	1
7	Bolt, M12 x 75-8.8 Hex Head Zinc	F81004-21	2
8	Washer, 13 Flat Zinc	F81056-1	2
9	Nut, M12-8 Hex Nylon Zinc Lock	F81034-2	3
10	Washer, 15 Special Flat Zinc	F81057-3	1
11	Bolt, M12 x 35-8.8 Hex Head Full Thread Zinc	F81004-24	1
12	Fitting, 3/16" Straight Grease	P04107	2
	ROLLER KIT, SIDE SUPPORT	015109	1
13	Roller Assembly, Side Support	015014	2

14	Washer, 5/8" Zinc-plated	F05011-5	4	
15	Bolt, 5/8-11 x 3" Hex Head Grade 5	F05009-37	1	
16	Nut, 5/8-11 Nylon Lock Zinc	F05010-34	1	
17	WASHER, SPECIAL BOSART/2S, BN781 M12/13	F81056-16	1	
18	WASHER, SPECIAL BOSART/2S M12/12,3/30,3	F81056-17	1	
	Instruction Sheet, Side Support Roller	015109-526	1	

6.11 Mast Track Extension & Chain

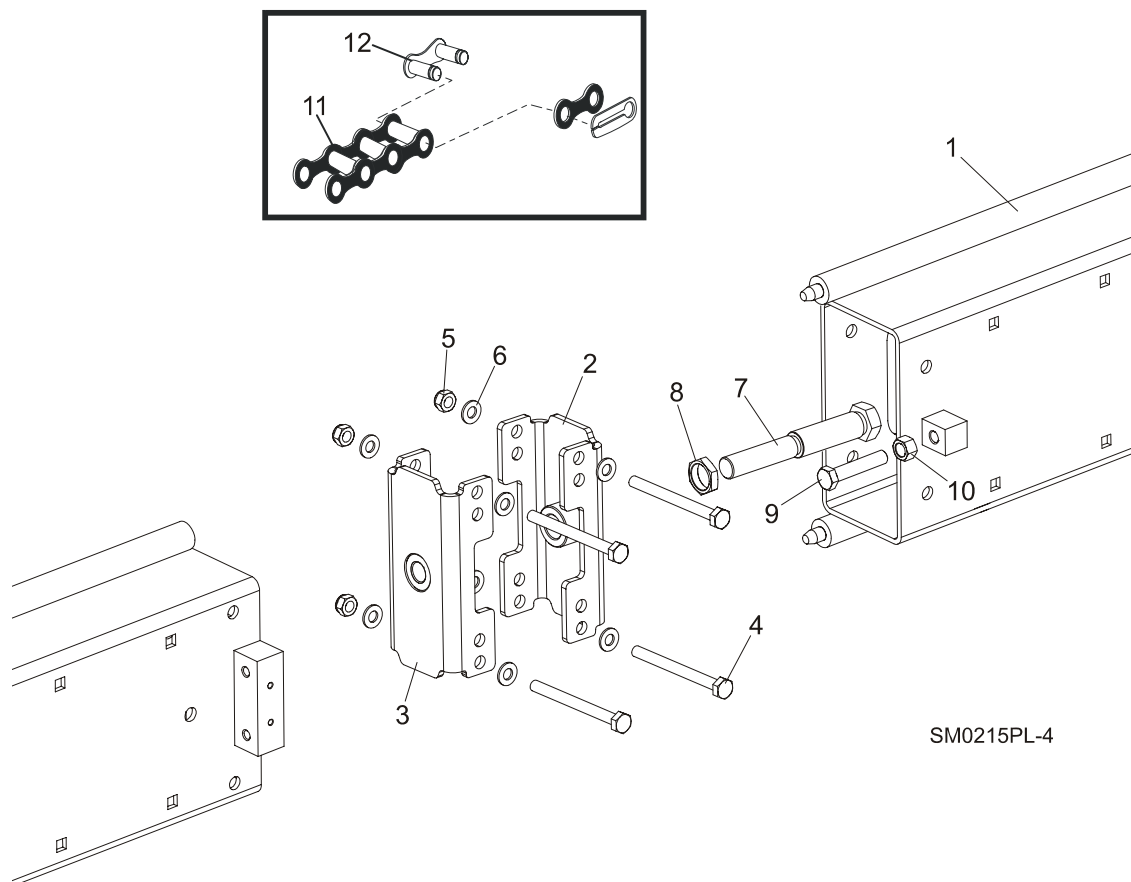

REF.	DESCRIPTION (◆ Indicates Parts Available In Assemblies Only)	PART #	QTY.
1	EXTENSION, 20" MAST TRACK - COMPLETE (LT20)	093775	1
	EXTENSION, 20" MAST TRACK - COMPLETE (LT40)	093775-40	1
	EXTENSION, 20" MAST TRACK - COMPLETE (LT70)	093775-70	1
	CONNECTOR, BX COMPLETE	501340	1
2	Connector, BX (M24)	500989-1	1
3	Connector, BX (M20)	501339-1	1
4	Bolt, M10 x 115-8.8 Hex Head Zinc	F81003-19	4
5	Nut, M10-8-B Hex Nylon Zinc Lock	F81033-1	4
6	Washer, 10.5 Flat Zinc	F81055-1	8
7	Bolt, Special Zinc-plated	087188-1	1
8	Nut, M24x2 LH Special Zinc-plated	087626-1	1
9	BOLT, M12 X 60-8.8 HEX HEAD FULL THREAD ZINC	F81004-51	1
10	NUT, M12-8-B HEX ZINC	F81034-1	1

11	CHAIN ASSEMBLY, EXTENSION (LT40)	094263	1	
	Chain, #40, 20.5" (41 Links)	094261	1	
	CHAIN ASSEMBLY, EXTENSION (LT70)	094264	1	
	Chain, Type 10B-1 20 5/8" (33 Links)	094262	1	
	CHAIN #40 X 75 1/2" (BX6)	P11602	1	
	CHAIN #40 X 143 1/2" (BX12)	P07355	1	
	CHAIN #40 X 286 1/2" (BX24)	P11909	1	
12	LINK, #40 MASTER	P04200 ¹	1	
	LINK, 10B-1Pz MASTER	088671 ²	1	

¹ Included also in assembly # 094263.

² Included in assembly #094264.

6.12 Bed Extension Stationary Legs

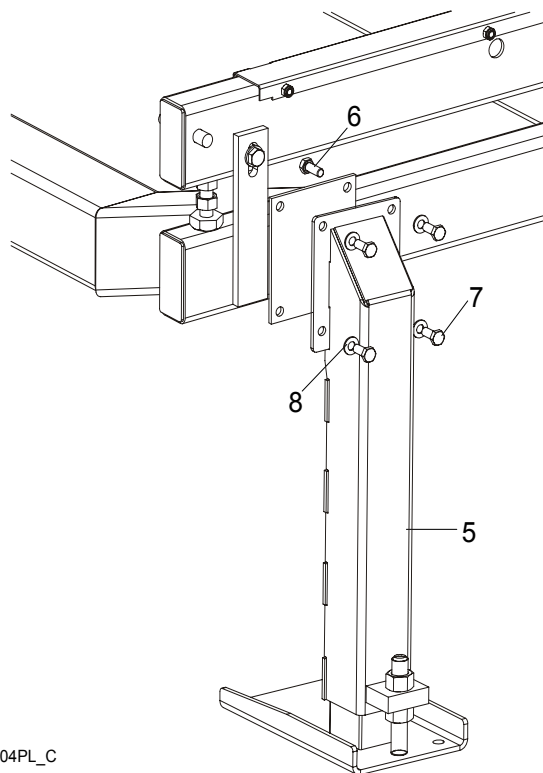
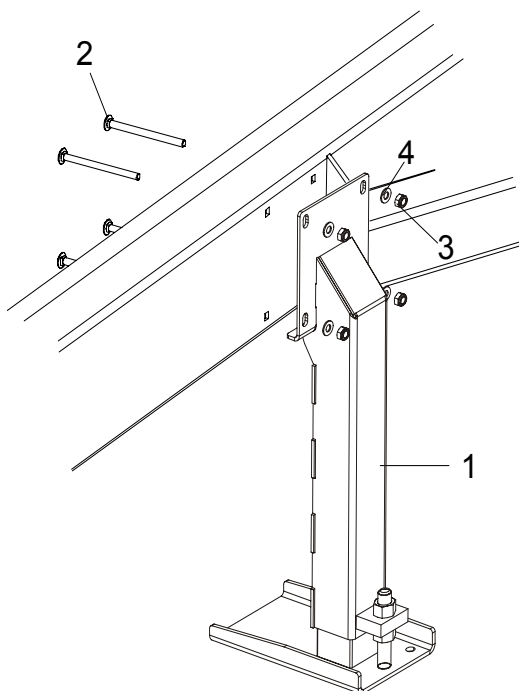

SM0204PL_C

REF.	DESCRIPTION (◆ Indicates Parts Available In Assemblies Only)	PART #	QTY.
1	LEG, RIGHT ADJUSTABLE STATIONARY (2 REQUIRED FOR BX6 & BX12; 4 FOR BX24)	501640	2/4
2	BOLT, M10 X 120 8.8 CARRIAGE HEAD ZINC	F81003-33	8/12
3	NUT, M10-8-B HEX NYLON ZINC LOCK	F81033-1	8/12
4	WASHER, 10.5 FLAT ZINC	F81055-1	8/12
5	LEG, LEFT ADJUSTABLE STATIONARY (2 REQUIRED FOR BX6 & BX12; 3 FOR BX24)	501639	2/3
6	BOLT, M10 X 25-8.8 HEX HEAD FULL THREAD ZINC	F81003-11	8/12
7	NUT, M10-8-B HEX NYLON ZINC LOCK	F81033-1	8/12
8	WASHER, 10.5 FLAT ZINC	F81055-1	8/12

6.13 Middle Stationary Legs (BX24 Only)

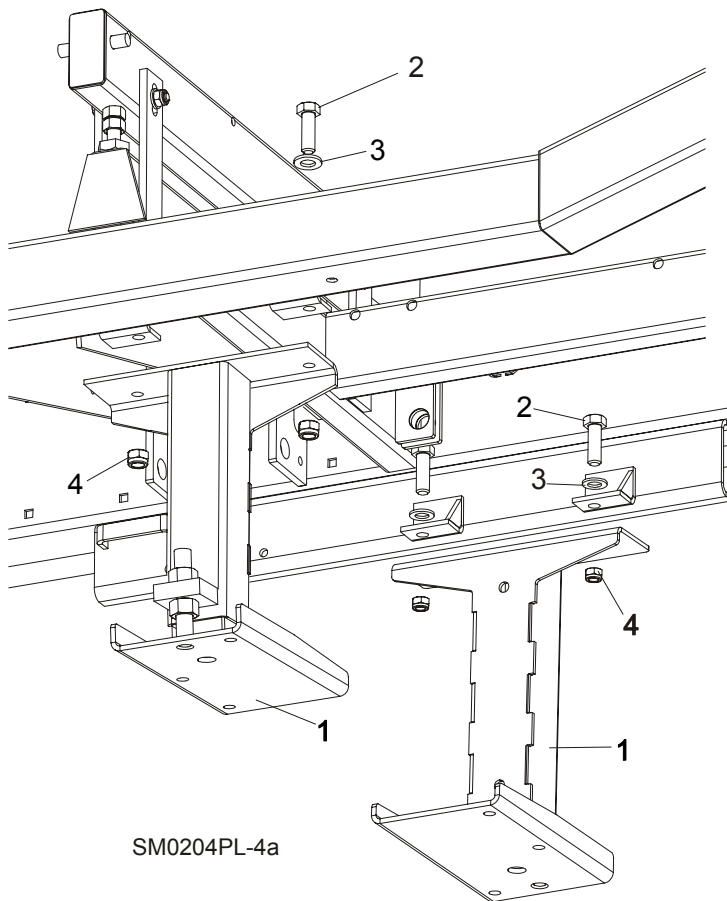

REF.	DESCRIPTION (◆ Indicates Parts Available In Assemblies Only)	PART #	QTY.
1	LEG, MIDDLE ADJUSTABLE STATIONARY	501637	2
2	BOLT, M12 X 30-8.8 HEX HEAD FULL THREAD ZINC	F81004-22	4
3	WASHER, 13 FLAT ZINC	F81056-1	4
4	NUT, M12-8 HEX NYLON ZINC LOCK	F81034-2	4

6.14 Fine Adjust Outrigger Leg

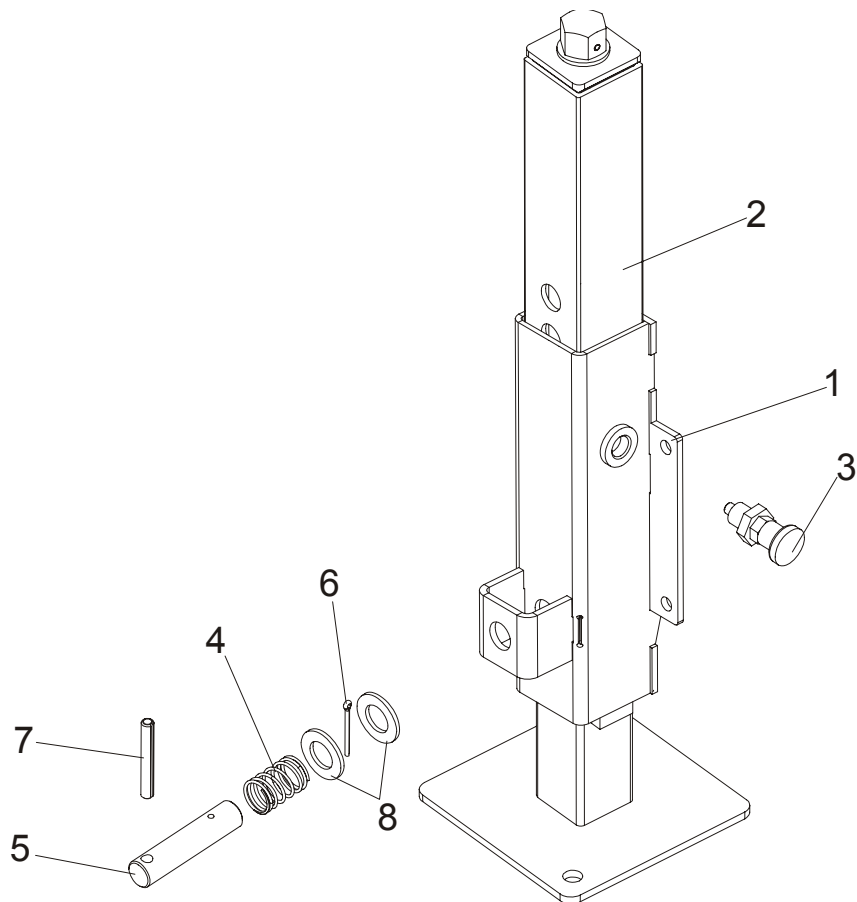

SMTUV22a

REF.	DESCRIPTION (◆ Indicates Parts Available In Assemblies Only)	PART #	QTY.
	LEG, COMPLETE FINE ADJUST OUTRIGGER (MAIN BED TUBE)	094584	1
1	Guide, Fine Adjust Outrigger Leg	506114-1	1
2	Leg, Fine Adjust Outrigger	093589	1
3	Pin, Detent	090197	1
4	Spring, 21 Dia. x 38 x 2 Zinc-plated	087040	1
5	Pin, Outrigger Leg Zinc-plated	087012-1	1
6	Pin, S-Zn 4x25 Cotter	F81043-2	1
7	Pin, 8x65 Roll Zinc	F81046-1	1
8	Washer, 21 Flat Zinc	F81059-2	2

6.15 Side Fine Adjust Outrigger Leg

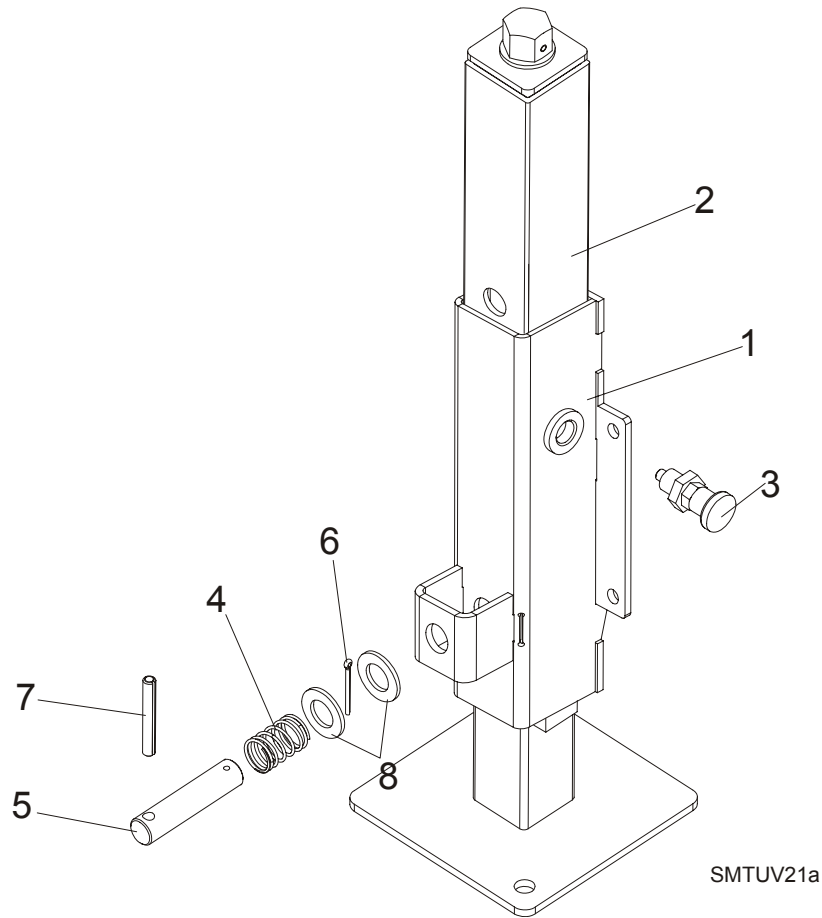

REF.	DESCRIPTION (◆ Indicates Parts Available In Assemblies Only)	PART #	QTY.
	LEG, COMPLETE SIDE FINE ADJUST OUTRIGGER	094583	1
1	Guide, Fine Adjust Outrigger Leg	504243-1	1
2	Leg, Fine Adjust Outrigger	093589	1
3	Din, Detent	090197	1
4	Spring, 21 Dia. x 38 x 2 Zinc-plated	087040	1
5	Pin, Outrigger Leg Zinc-plated	087012-1	1
6	Pin, S-Zn 4x25 Cotter	F81043-2	1
7	Pin, 8x65 Roll Zinc	F81046-1	1
8	Washer, 21 Flat Zinc	F81059-2	2

6.16 Manual Log Clamp (manual bed extension equipment: 24M)

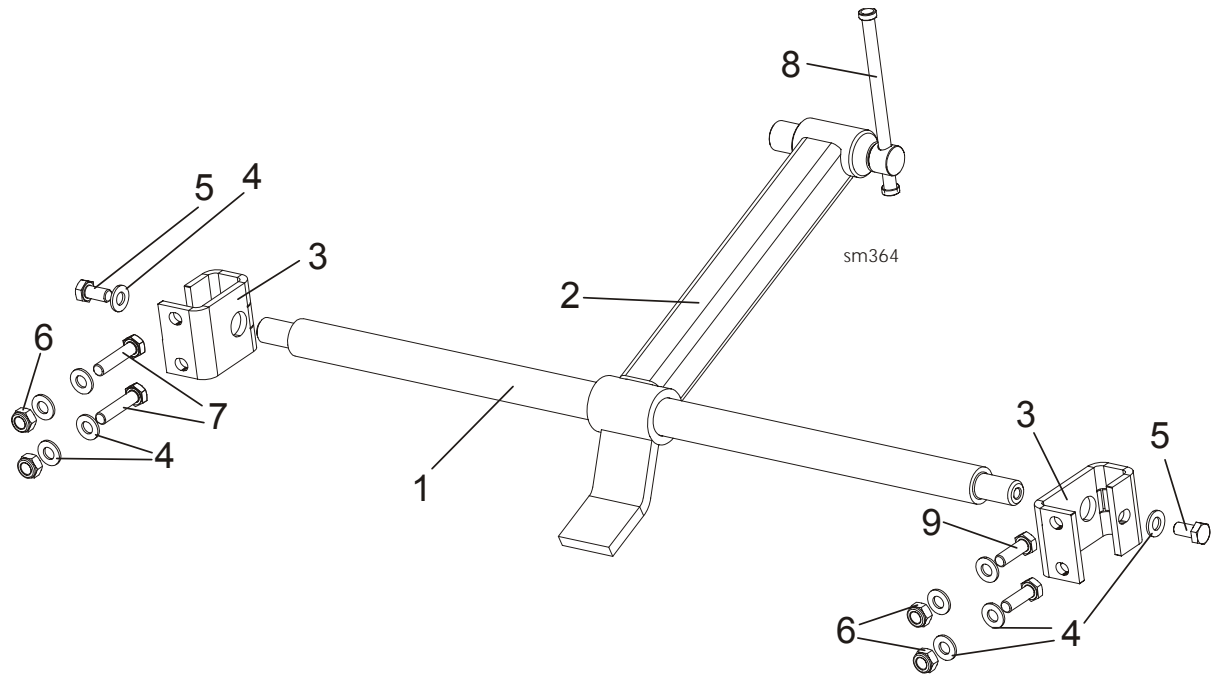

REF	DESCRIPTION (◆ Indicates Parts Available In Assemblies Only)	PART #	QTY.
	BED EXTENSION LOG CLAMP	505726	1
1	ROD MAIN CLAMP	100643	1
2	CLAMP ARM	507566-1	1
3	BRACKET, LOG CLAMP MOUNT ZINC	500338-1	2
4	WASHER, 10.5 FLAT ZINC	F81055-1	10
5	BOLT, M10x20MM,HEX HEAD,GR 5.8 ZINC	F81003-1	2
6	NUT,M10-8-B NYLON HEX ZINC LOCK	F81033-1	4
7	BOLT,M10X90-8.8 HEX HEAD FULL THREA	F81003-66	2
8	CLAMP BOLT KPL.	507563	1
9	BOLT,M10X35-8.8 HEX HEAD FULL THREA	F81003-17	2

6.17 Brace Assembly, SBX6

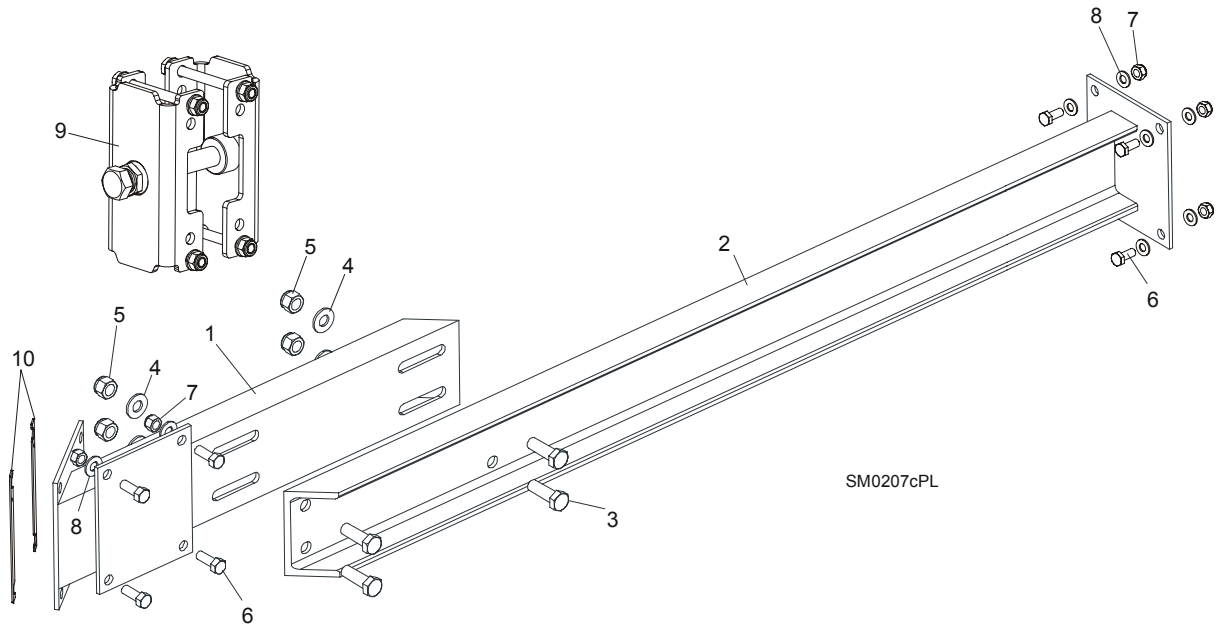

REF.	DESCRIPTION (◆ Indicates Parts Available In Assemblies Only)	PART #	QTY.	
	BRACE ASSEMBLY, SBX6	092987	1	
1	Channel, LT30 BX Brace - Short	085653-1	1	
2	Channel, BX6 Brace - Long	092986-1	1	
3	Bolt, M12 x 35 8.8 Hex Head Full Thread Zinc	F81004-24	4	
4	Washer, 13 Flat Zinc	F81056-1	4	
5	Nut, M12-8 Hex Nylon Zinc Lock	F81034-2	4	
6	Bolt, M10 x 25-8.8 Hex Head Full Thread Zinc	F81003-11	4	
7	Nut, M10-8-B Hex Nylon Zinc Lock	F81033-1	4	
8	Washer, 10.5 Flat Zinc	F81055-1	4	
9	Connector, BX Complete	501340	1	
10	WASHER, SPECIAL	086649-1	2	

6.18 Brace Assembly, MBX6

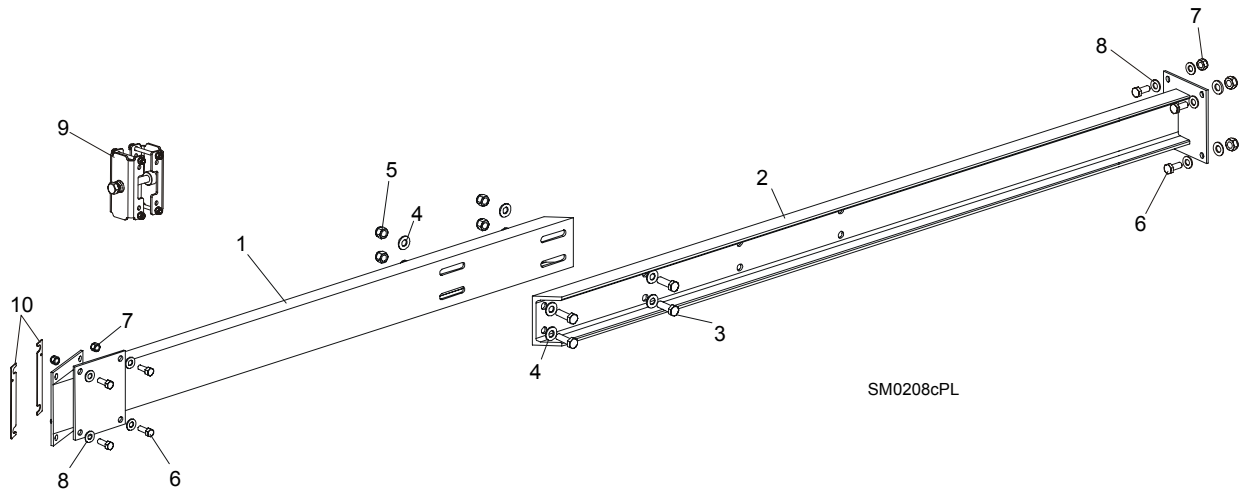

REF.	DESCRIPTION (◆ Indicates Parts Available In Assemblies Only)	PART #	QTY.
	BRACE ASSEMBLY, MBX6	092988	1
1	Channel, LT40 BX Brace	092824-1	1
2	Channel, BX6/BX12 Brace	085651-1	1
3	Bolt, M12 x 40-8.8 Hex Head Full Thread Zinc	F81004-4	4
4	Washer, 13 Flat Zinc	F81056-1	8
5	Nut, M12-8 Hex Nylon Zinc Lock	F81034-2	4
6	Bolt, M10 x 25-8.8 Hex Head Full Thread Zinc	F81003-11	4
7	Nut, M10-8-B Hex Nylon Zinc Lock	F81033-1	4
8	Washer, 10.5 Flat Zinc	F81055-1	4
9	Connector, BX Complete	501340	1
10	WASHER, SPECIAL	086649-1	2

6.19 LBX6 Connection Bracket

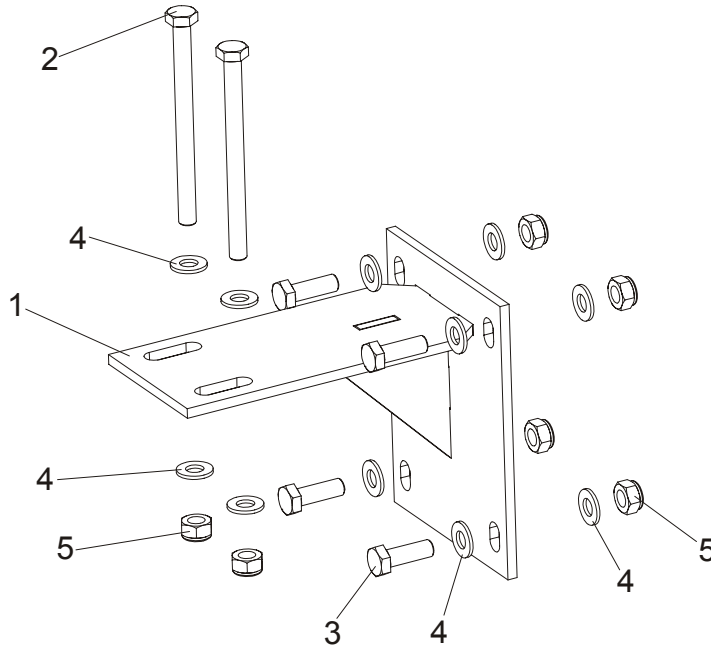

REF.	DESCRIPTION (◆ Indicates Parts Available In Assemblies Only)	PART #	QTY.
1	Bracket, BX Connection (9.5m Frame)	090034-1	1
2	Bolt, M10x125-8.8 Hex Head Zinc	F81003-18	2
3	Bolt, M10x30-5.8 Hex Head Full Thread Zinc	F81003-2	4
4	Washer, 10.5 Flat Zinc	F81055-1	12
5	Nut, M10-8-B Hex Nylon Zinc Lock	F81033-1	6

6.20 Brace Assembly, SBX12

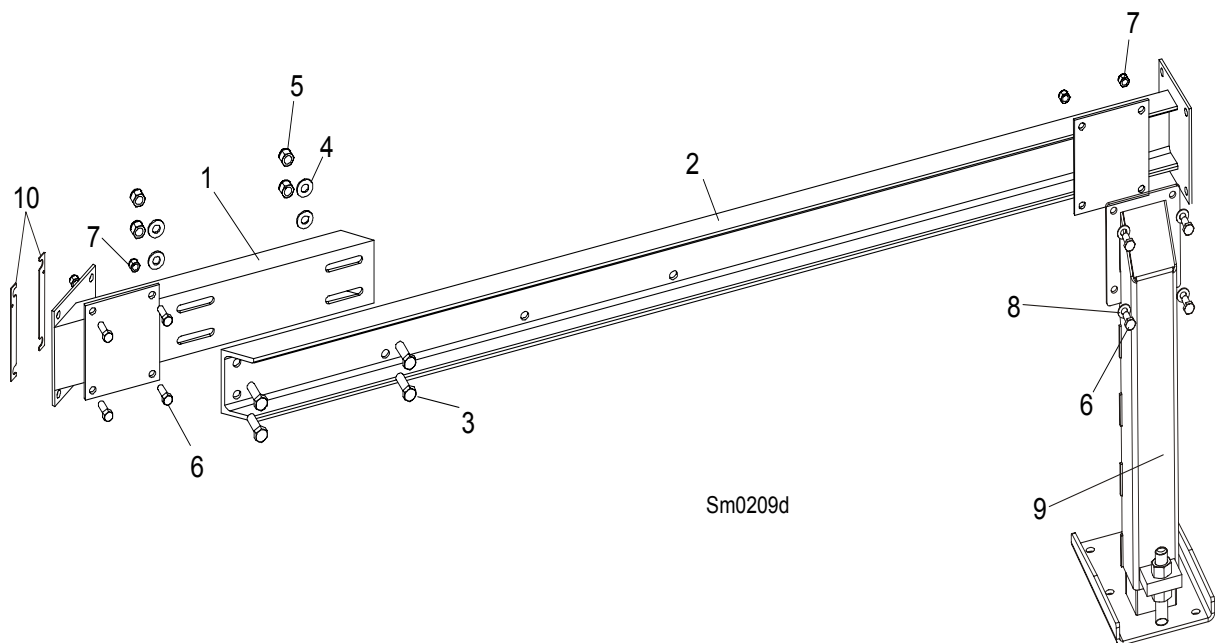

REF.	DESCRIPTION (◆ Indicates Parts Available In Assemblies Only)	PART #	QTY.
	BRACE ASSEMBLY, SBX12	092888	1
1	Channel, LT40S BX Brace - Short	085653-1	1
2	Channel, BX12 Brace - Long	092825-1	1
3	Bolt, M12 x 35-8.8 Hex Head Full Thread Zinc	F81004-24	4
4	Washer, 13 Flat Zinc	F81056-1	8
5	Nut, M12-8 Hex Nylon Zinc Lock	F81034-2	4
6	Bolt, M10 x 25-8.8 Hex Head Full Thread Zinc	F81003-11	12
7	Nut, M10-8-B Hex Nylon Zinc Lock	F81033-1	12
8	Washer, 10.5 Flat Zinc	F81055-1	24
9	Leg, Left Stationary Adjustable	501639	1
10	WASHER, SPECIAL	086649-1	2

6.21 Brace Assembly, MBX12

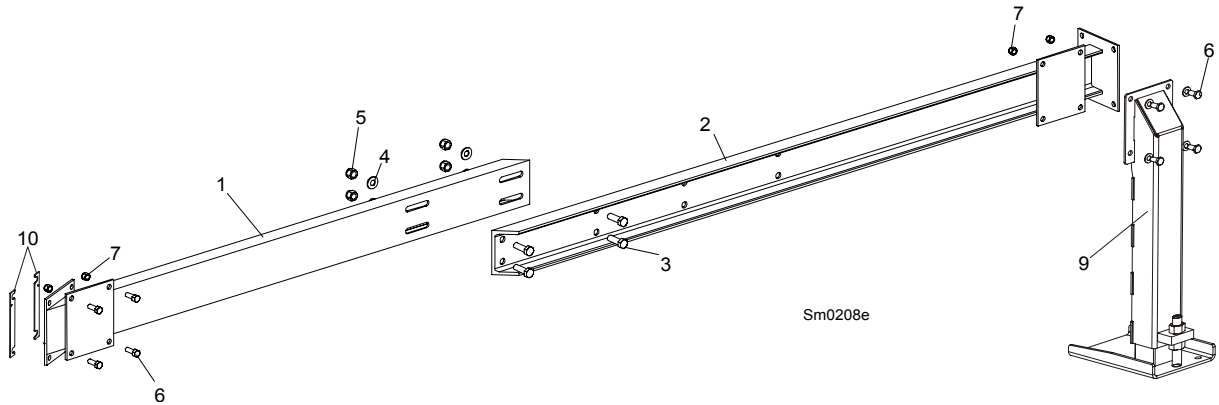

REF.	DESCRIPTION (◆ Indicates Parts Available In Assemblies Only)	PART #	QTY.
	BRACE ASSEMBLY, LT40/LT40HD BX6/BX12	092887	1
1	Channel, LT40M BX Brace	092824-1	1
2	Channel, BX6/BX12 Brace	092823-1	1
3	Bolt, M12 x 35-8.8 Hex Head Full Thread Zinc	F81004-24	4
4	Washer, 13 Flat Zinc	F81056-1	8
5	Nut, M12-8 Hex Nylon Zinc Lock	F81034-2	4
6	Bolt, M10 x 25-8.8 Hex Head Full Thread Zinc	F81003-11	12
7	Nut, M10-8-B Hex Nylon Zinc Lock	F81033-1	12
8	Washer, 10.5 Flat Zinc	F81055-1	24
9	Leg, Left Stationary Adjustable	501639	1
10	WASHER, SPECIAL	086649-1	2

6.22 Brace Assembly, LBX12

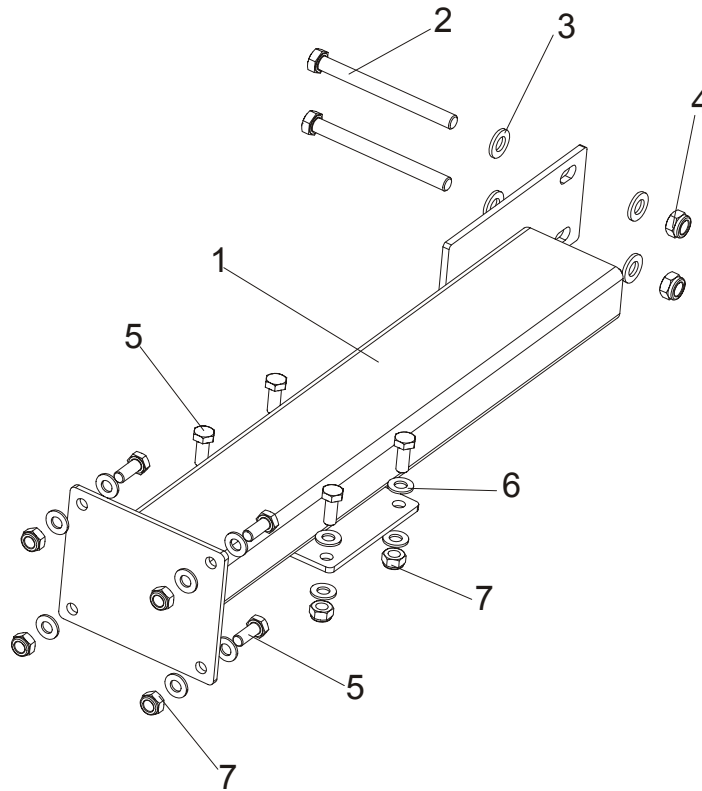

REF.	DESCRIPTION (◆ Indicates Parts Available In Assemblies Only)	PART #	QTY.
	BRACE ASSEMBLY, 40LBX12	094834	1
1	Tube, 40LBX12 Brace Ptd	091177-1	1
2	Bolt, M12x130-8.8 Hex Head Zinc	F81004-36	2
3	Washer, 13 Flat Zinc	F81056-1	4
4	Nut, M12-8 Hex Nylon Zinc Lock	F81034-2	2
5	Bolt, M10x25-8.8 Hex Head Full Thread Zinc	F81003-11	8
6	Washer, 10.5 Flat Zinc	F81055-1	16
7	Nut, M10-8-B Hex Nylon Zinc Lock	F81033-1	8

6.23 Brace Assembly, SBX24

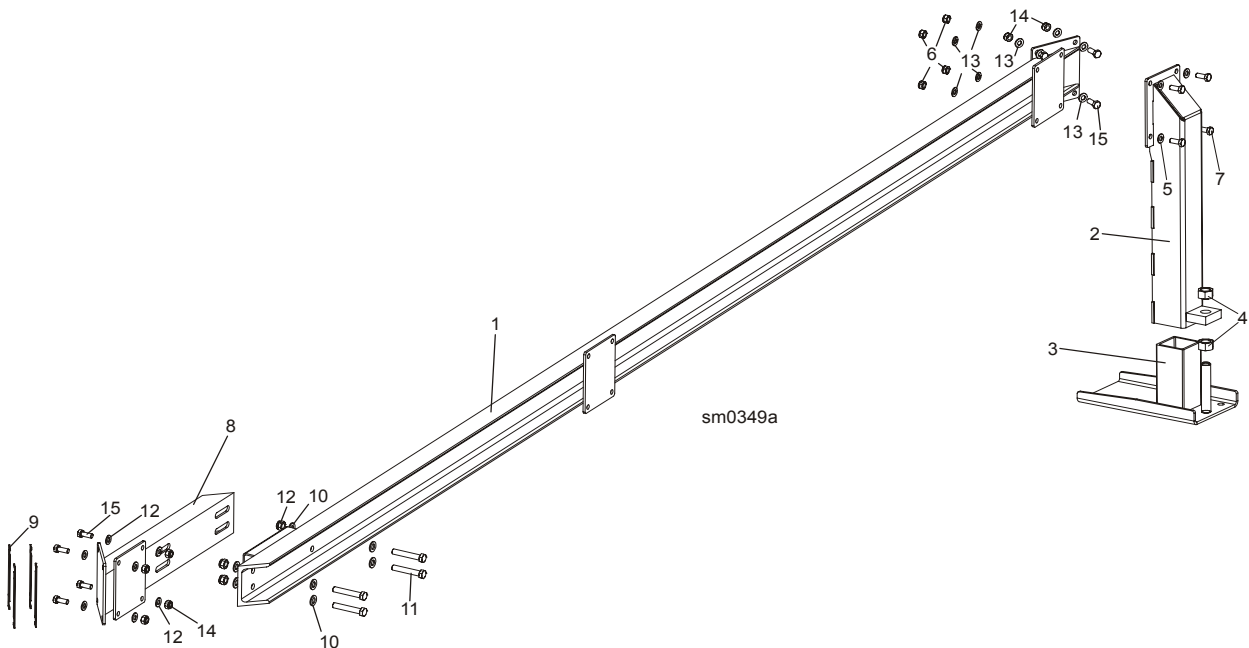

REF.	DESCRIPTION (◆ Indicates Parts Available In Assemblies Only)	PART #	QTY.
	BRACE ASSEMBLY, SBX24	093931	1
1	CHANNEL, SBX24 W/MOUNT PLATE - LONG	093143-1	1
	LEG, LEFT STATIONARY ADJUSTABLE	501639	1
2	LEG WELDMENT - UPPER PART	507715-1	1
3	WIDE FOOT - ADJUSTABLE LEGS	501084-1	1
4	NUT, M20-8 HEX ZINC	F81037-1	2
5	WASHER, 10.5 FLAT ZINC	F81055-1	4
6	NUT, M10-8-B HEX NYLON ZINC LOCK	F81033-1	4
7	BOLT, M10x25-8.8 HEX HEAD FULL THREAD ZINC	F81003-11	4
8	CHANNEL, BX BRACE - SHORT	085653-1	1
9	SHIM, BX6 PTD	086649-1	4
10	WASHER, 13 FLAT ZINC	F81056-1	8
11	BOLT, M12x70 8.8 HEX HEAD ZINC	F81004-39	4
12	NUT, M12-8 HEX NYLON ZINC LOCK	F81034-2	4
13	WASHER, 10.5 FLAT ZINC	F81055-1	20
14	NUT, M10-8-B HEX NYLON ZINC LOCK	F81033-1	8
15	BOLT, M10x25-8.8 HEX HEAD FULL THREAD ZINC	F81003-11	8

6.24 Brace Assembly, MBX24

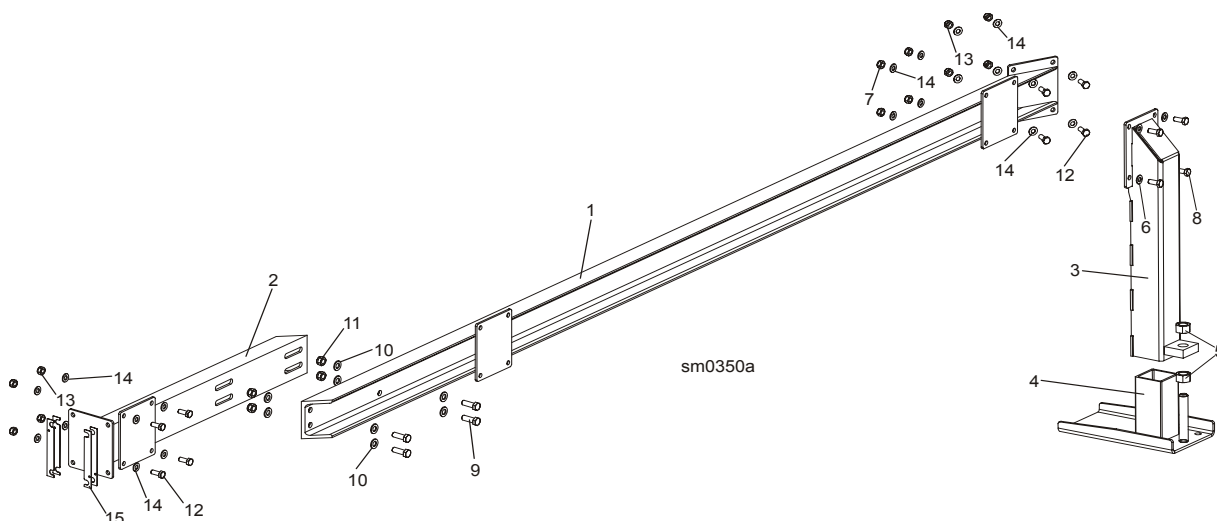

REF.	DESCRIPTION (◆ Indicates Parts Available In Assemblies Only)	PART #	QTY.
	BRACE ASSEMBLY, MBX24-AH5/7, DH5/7	095632	1
1	CHANNEL, MBX24 W/MOUNT PLATE - LONG	095629-1	1
2	CHANNEL, MBX24 BRACE - SHORT	095631-1	1
	LEG, LEFT STATIONARY ADJUSTABLE	501639	1
3	LEG WELDMENT - UPPER PART	507715-1	1
4	WIDE FOOT - ADJUSTABLE LEGS	501084-1	1
5	NUT, M20-8 HEX ZINC	F81037-1	2
6	WASHER, 10.5 FLAT ZINC	F81055-1	4
7	NUT, M10-8-B HEX NYLON ZINC LOCK	F81033-1	4
8	BOLT, M10x25-8.8 HEX HEAD FULL THREAD ZINC	F81003-11	4
9	BOLT, M12 x 35-8.8 HEX HEAD FULL THREAD ZINC	F81004-24	4
10	WASHER, 13 FLAT ZINC	F81056-1	8
11	NUT, M12-8 HEX NYLON ZINC LOCK	F81034-2	4
12	BOLT, M10 x 25-8.8 HEX HEAD FULL THREAD ZINC	F81003-11	8
13	NUT, M10-8-B HEX NYLON ZINC LOCK	F81033-1	8
14	WASHER, 10.5 FLAT ZINC	F81055-1	20
15	SHIM, BX6 PTD	086649-1	4

6.25 Brace Assembly, LBX24

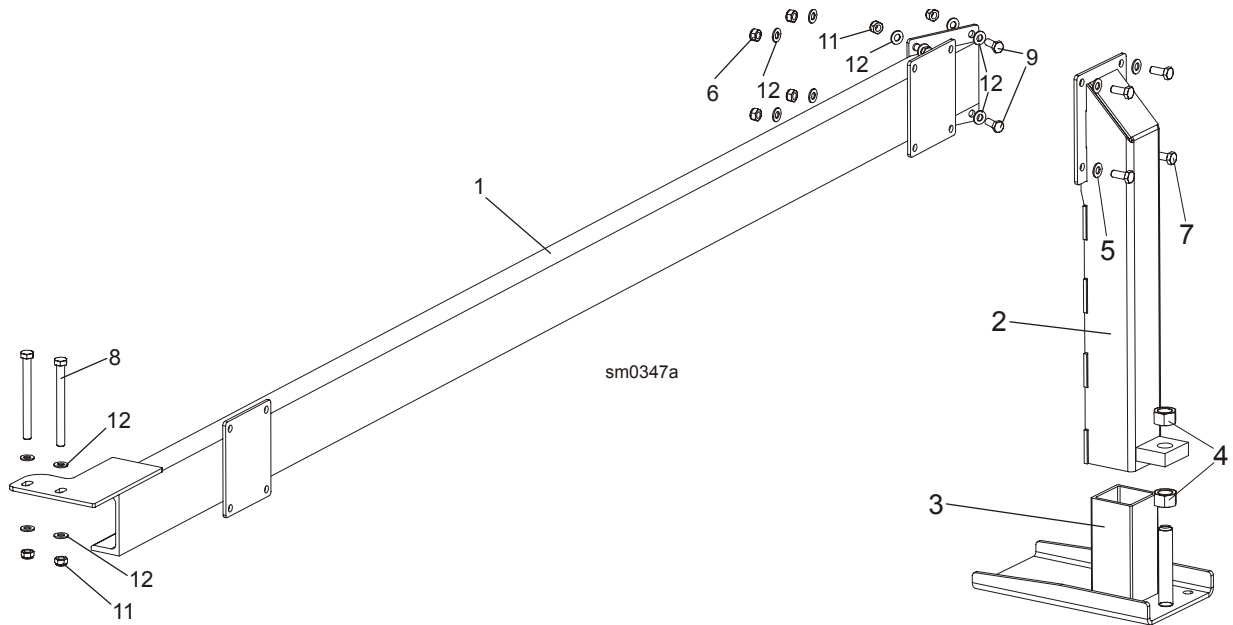

REF.	DESCRIPTION (◆ Indicates Parts Available In Assemblies Only)	PART #	QTY.
	BRACE ASSEMBLY, LBX24	501661	1
1	CHANNEL, LBX24 W/MOUNT PLATE	501662-1	1
	LEG, LEFT STATIONARY ADJUSTABLE	501639	1
2	LEG WELDMENT - UPPER PART	507715-1	1
3	WIDE FOOT - ADJUSTABLE LEGS	501084-1	1
4	NUT, M20-8 HEX ZINC	F81037-1	2
5	WASHER, 10.5 FLAT ZINC	F81055-1	4
6	NUT, M10-8-B HEX NYLON ZINC LOCK	F81033-1	4
7	BOLT, M10x25-8.8 HEX HEAD FULL THREAD ZINC	F81003-11	4
8	BOLT, M12x130-8.8 HEX HEAD ZINC	F81004-36	2
9	BOLT, M10x25-8.8 HEX HEAD FULL THREAD ZINC	F81003-11	4
10	NUT, M12-8-B HEX ZINC	F81034-1	4
11	NUT, M10-8-B HEX NYLON ZINC LOCK	F81033-1	6
12	WASHER, 10.5 FLAT ZINC	F81055-1	16

6.26 Brace Assembly, MBX24 Super

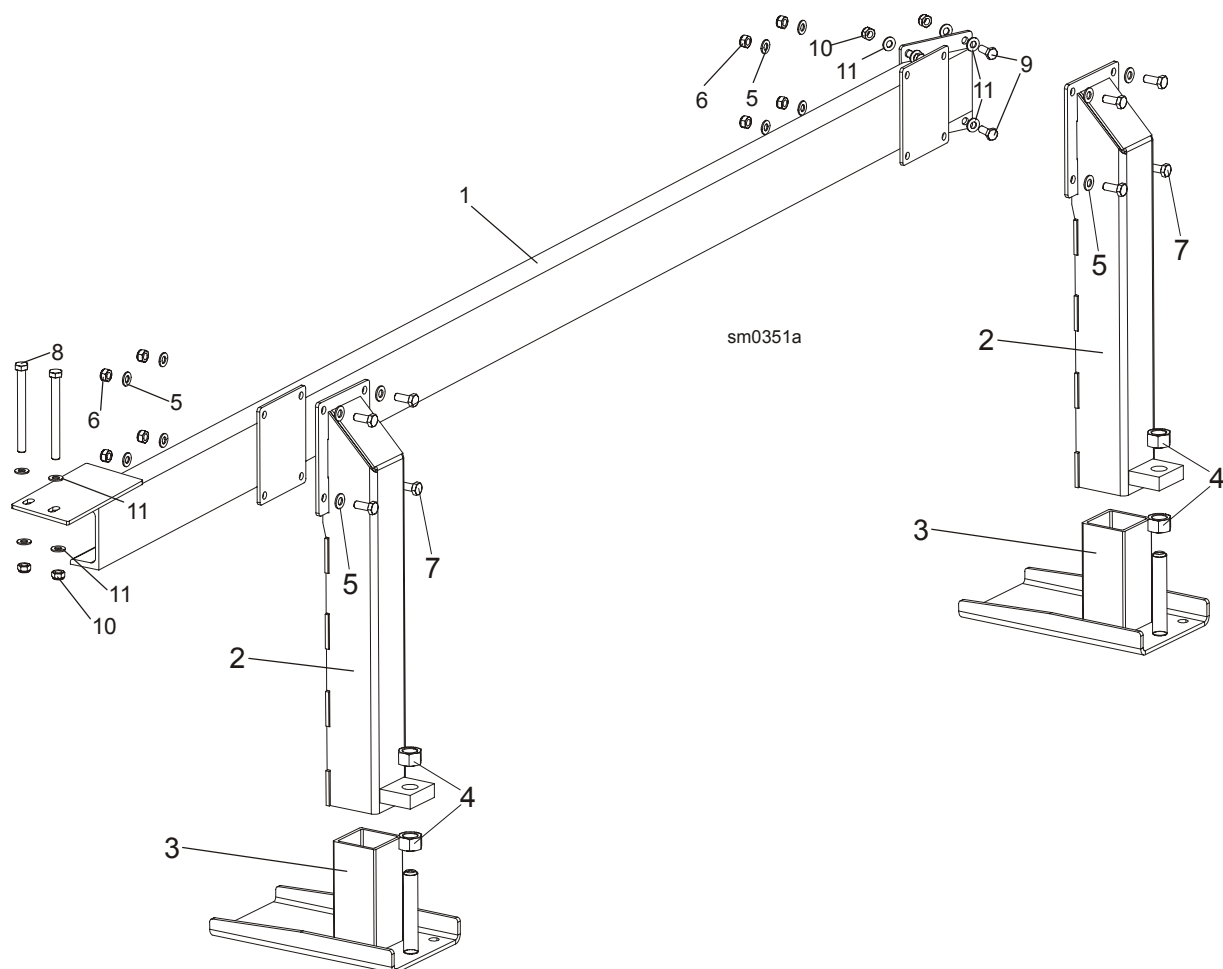

REF.	DESCRIPTION (◆ Indicates Parts Available In Assemblies Only)	PART #	QTY.
	BRACE ASSEMBLY, MBX24 SUPER	099197	1
1	CHANNEL, MBX24 W/MOUNT PLATE PTD	099201-1	1
	LEG, LEFT STATIONARY ADJUSTABLE	501639	2
2	LEG WELDMENT - UPPER PART	507715-1	1
3	WIDE FOOT - ADJUSTABLE LEGS	501084-1	1
4	NUT, M20-8 HEX ZINC	F81037-1	2
5	WASHER, 10.5 FLAT ZINC	F81055-1	4
6	NUT, M10-8-B HEX NYLON ZINC LOCK	F81033-1	4
7	BOLT, M10x25-8.8 HEX HEAD FULL THREAD ZINC	F81003-11	4
8	BOLT, M10x125-8.8 HEX HEAD ZINC	F81003-18	2
9	BOLT, M10x30-5.8 HEX HEAD FULL THREAD ZINC	F81003-2	4
10	NUT, M10-8-B HEX NYLON ZINC LOCK	F81033-1	6
11	WASHER, 10.5 FLAT ZINC	F81055-1	16

6.27 Bed Extension, MBX6 Super

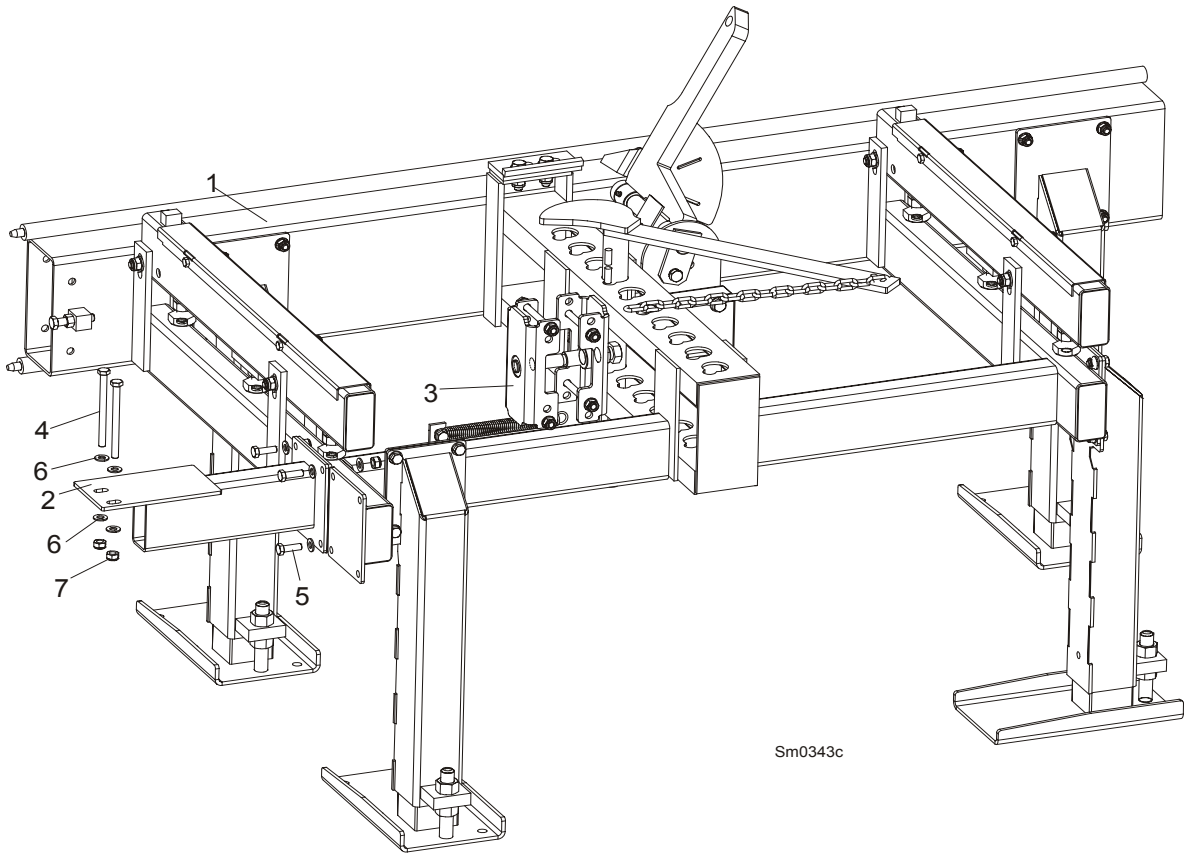

REF.	DESCRIPTION (◆ Indicates Parts Available In Assemblies Only)	PART #	QTY.
	EXTENSION, MBX6 SUPER BED	40MBX6S	1
	EXTENSION, MBX6 SUPER BED	70MBX6S	1
1	EXTENSION, BX6 1.8m (6') BED - COMPLETE	BX6	1
	BRACE, MBX6 SUPER COMPLETE	099198	1
2	BRACE, MBX6 SUPER	099199-1	1
3	CONNECTOR, BX COMPLETE	501340	1
4	BOLT, M10x125-8.8 HEX HEAD ZINC	F81003-18	2
5	BOLT, M10x30-5.8 HEX HEAD FULL THREAD ZINC	F81003-2	4
6	WASHER, 10.5 FLAT ZINC	F81055-1	12
7	NUT, M10-8-B HEX NYLON ZINC LOCK	F81033-1	6

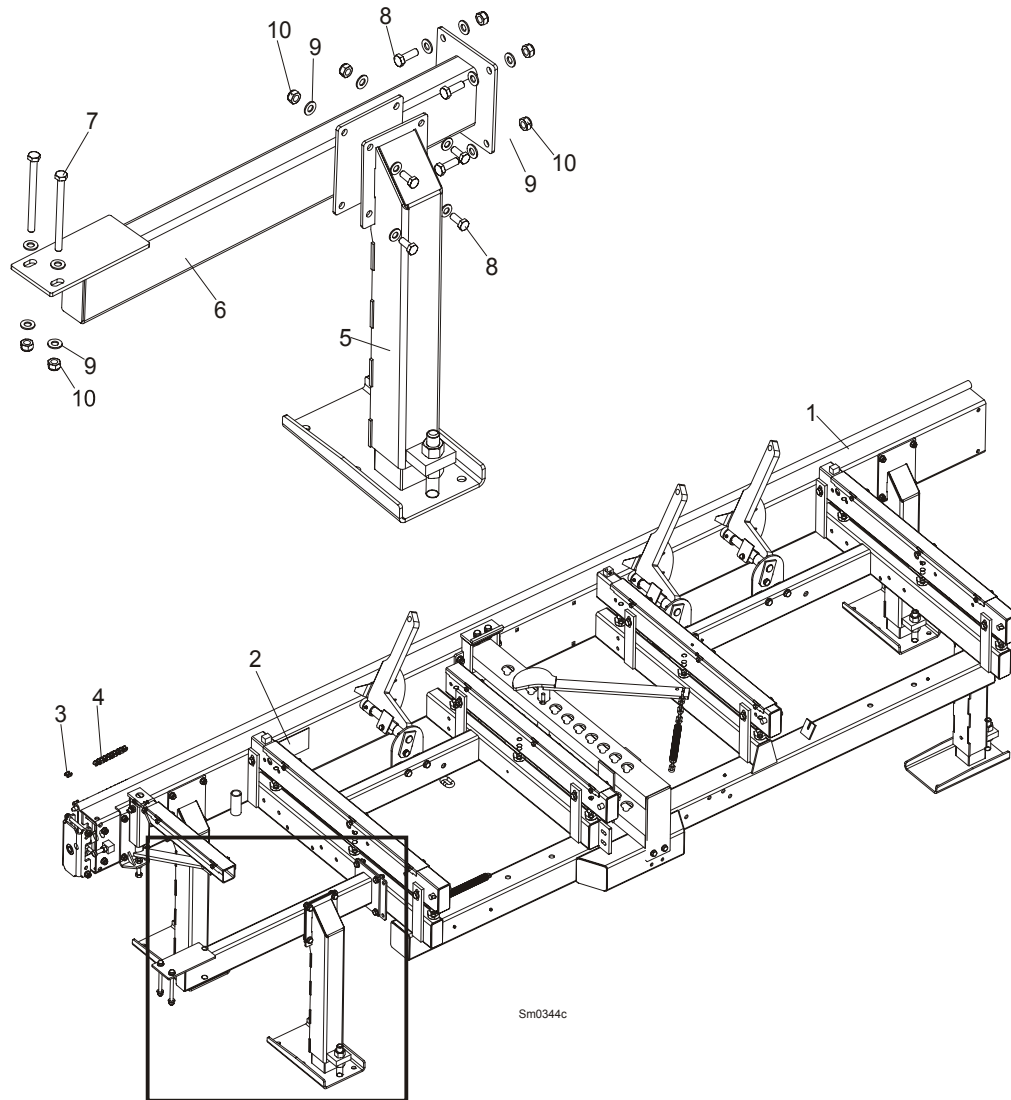
6.28 Bed Extension, MBX12 Super

REF.	DESCRIPTION (◆ Indicates Parts Available In Assemblies Only)	PART #	QTY.
	EXTENSION, MBX12 SUPER BED	40MBX12S	1
	EXTENSION, MBX12 SUPER BED	70MBX12S	1
1	EXTENSION, BX12 BED	092744	1
2	DECAL, 40MBX12 BED EXTENSION	093945	1
3	LINK, #40 MASTER	P04200	1
4	CHAIN, BED EXTENSION (3.6m)	P07355	1
	BRACE, BX12 SUPER COMPLETE	099630	1
5	LEG, LEFT ADJUSTABLE STATIONARY	501639	1
6	TUBE WELDMENT, BX12 BRACE	098733-1	1
7	BOLT, M10x125-8.8 HEX HEAD ZINC	F81003-18	2
8	BOLT, M10x30-5.8 HEX HEAD FULL THREAD ZINC	F81003-2	8
9	WASHER, 10.5 FLAT ZINC	F81055-1	20
10	NUT, M10-8-B HEX NYLON ZINC LOCK	F81033-1	10

6.29 Oil Flow Divider w/Hydraulic Hoses (BX24 & "M" Frame)

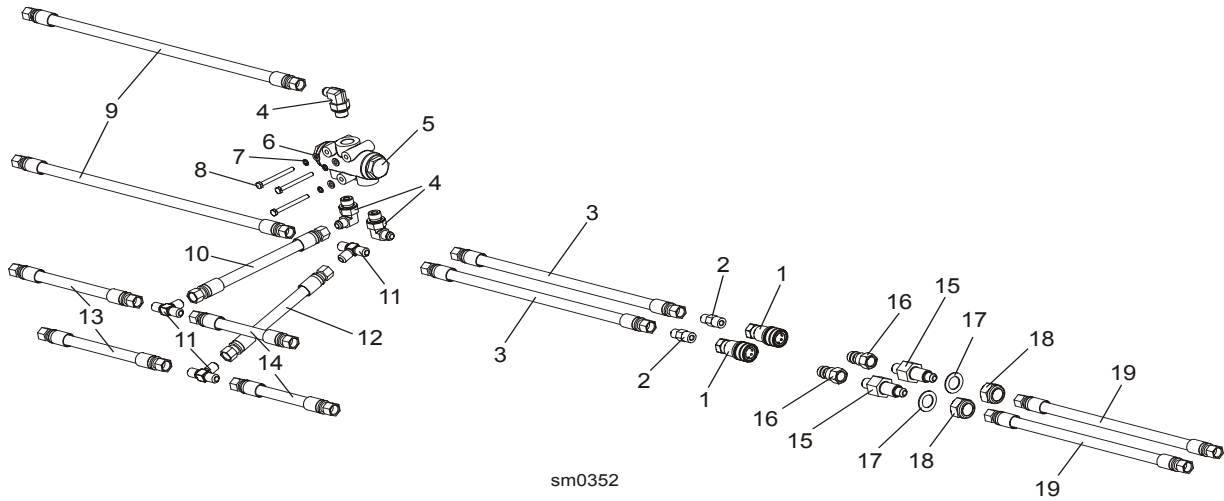

REF.	DESCRIPTION (◆ Indicates Parts Available In Assemblies Only)	PART #	QTY.
	OIL FLOW DIVIDER W/HYDRAULIC HOSES ("M" FRAME/BX24)	505838	1
1	FITTING, 3/8" INT.THREAD BSP FEMALE QUICK DISCONNECT	504965	2
2	FITTING, G3/8-9/16-18JIC HAND PUMP	091842	2
3	HOSE, 2T3/8X3.950 W9/16UNF-W9/16 UNF HYDRAULIC	505847	2
4	FITTING, 90 18x1,5 9/16-18 JIC ELBOW	089992	3
5	DIVIDER, MTD A 08-016M1/3 / 2/3 OIL FLOW	088190	1
6	WASHER, 6.4 FLAT ZINC	F81053-1	3
7	WASHER, Z 6.1 SPLIT LOCK ZINC	F81053-3	3
8	BOLT, M6x65-8.8 HEX HEAD ZINC	F81001-81	3
9	HOSE, PHD 2T3/8X4.950 W9/16UNF-W9/16 UNF HYDRAULIC	505848	2
10	HOSE, PHD 2T3/8X2.000 W9/16UNF-W9/16UNF HYDRAULIC	089853	1
11	FITTING, 3/8JIC TEE	015487	3
12	HOSE, PHD 2T3/8X1.533 W9/16UNF-W9/16UNF HYDRAULIC	099383	1
13	HOSE, PHD 2T3/8X1.900 W9/16UNF-W9/16UNF HYDRAULIC	089856	2
14	HOSE, PHD 2T3/8X1.200 W9/16UNF-W9/16UNF HYDRAULIC	089852	2
15	FITTING, Z3/8"BSP-Z9/16 UNF JIC REDUCER	504987-1	2
16	FITTING, 3/8" INT. THREAD BSP MALE QUICK DISCONNECT	504966	2
17	WASHER, 1940 DIA. (34/21.2/1.5)	506105	2
18	NUT, M20-8-A HEX NYLON ZINC LOCK	F81037-2	2
19	HOSE, PHD 2T3/8X3.800 W9/16UNF-W9/16 UNF HYDRAULIC	505846	2
20	LOG LOADER, SINGLE ARM See Section 6.30	090204	1
21	CHAIN, 9.5m SINGLE LOADING ARM See Section 6.30	090090	1

6.30 Log Loader (Single Arm)

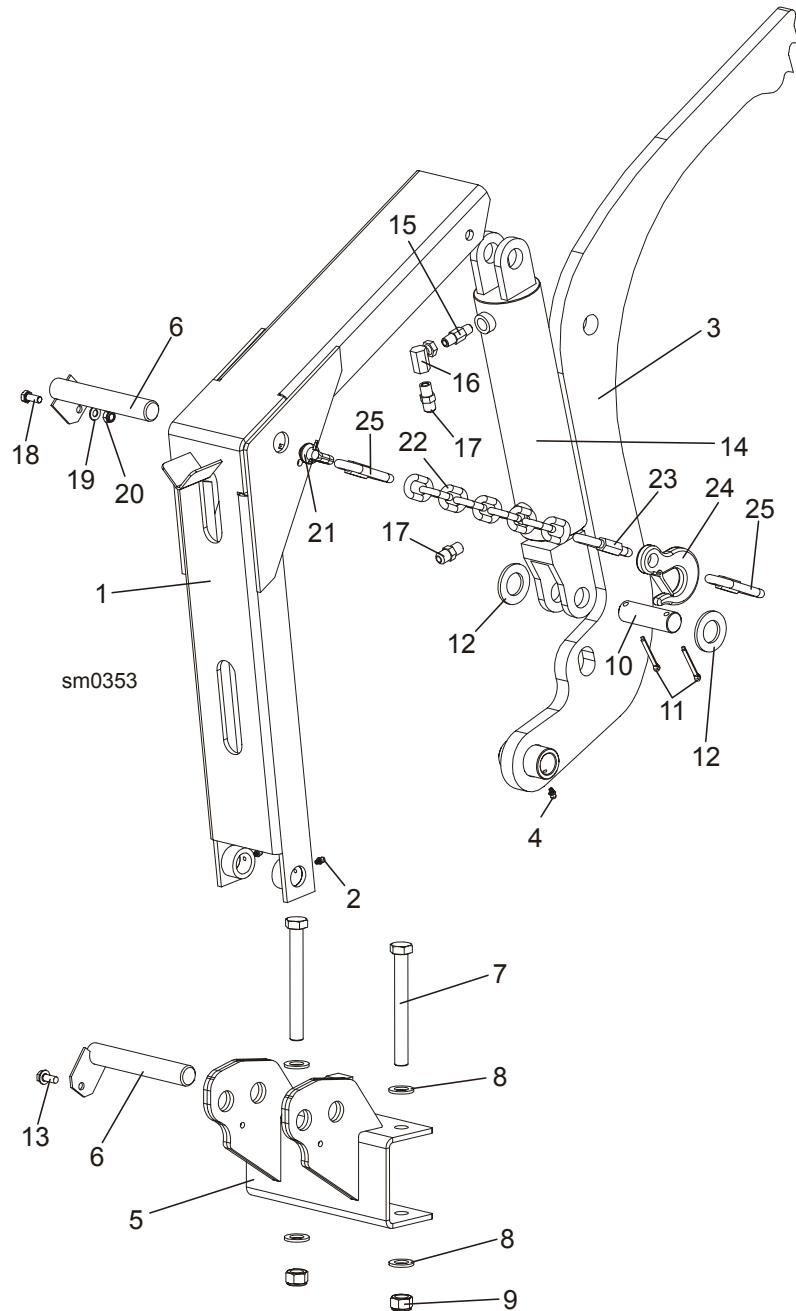

REF.	DESCRIPTION (◆ Indicates Parts Available In Assemblies Only)	PART #	QTY.
	LOG LOADER - SINGLE ARM	090204	1
	CHANNEL, LOG LOADER FOOT COMPLETE	090049	1
1	CHANNEL WELDMENT, LOG LOADER FOOT PTD	090048-1	1
2	FITTING, 3/16" STRAIGHT GREASE	P04107	2
	LOG LOADER SINGLE ARM (9.5M FRAME)	090051	1
3	ARM WELDMENT, LOG LOADER PTD	089657-1	1
4	FITTING, 3/16" STRAIGHT GREASE	P04107	1

5	BRACKET WELDMENT, SINGLE LOADING ARM PTD	089841-1	1	
6	PIN WELDMENT, LOG LOADER ZINC-PLATED	099127-1	2	
7	BOLT, M16x140-8.8 HEX HEAD ZINC	F81006-4	2	
8	WASHER, 17 FLAT ZINC	F81058-1	4	
9	NUT, M16-8 HEX NYLON ZINC LOCK	F81036-2	2	
10	PIN, HYDRAULIC CYLINDER ZINC-PLATED	086979-1	1	
11	FITTING, 3/8JIC TEE	F81043-31	2	
12	WASHER, 28 FLAT ZINC	F81061-1	2	
13	SCREW, 5/16-18 x 3/4 SELF-TAPPING	F05015-30	1	
	CYLINDER ASSEMBLY, LOG LOADING	015562	1	
14	CYLINDER, CJ-S95-16-70/32/203 HYDRAULIC	088680	1	
15	FITTING, 1/4NPT VELOCITY FUSE 5.0GPM	015750	1	
16	FITTING, 1/4NPT-1/4JIC SWIVEL ELBOW	P12199	1	
17	FITTING, 3/8JIC-1/4NPT STRAIGHT	015560	2	
18	BOLT, M8x20-8.8-B HEX HEAD FULL THREAD ZINC	F81002-4	1	
19	WASHER, 8.4 FLAT ZINC	F81054-1	1	
20	NUT, M8-8-B HEX NYLON ZINC LOCK	F81032-2	1	
21	SHACKLE, M12 TYPE C DIN 82101	086540	1	
	CHAIN, SINGLE LOADING ARM (9.5M FRAME)	090090-1	1	
22	CHAIN, 9.5M SINGLE LOADING ARM	090090	1	
23	LINK "10"	100767	1	
24	HOOK, 5/8 SAFETY CHAIN	P12075	1	
25	LINK "10"	100767	2	

SECTION 7 HYDRAULIC SYSTEM

7.1 Hydraulic Hose Hanger Kit, MBX24 Bed Extension (AH1-3)

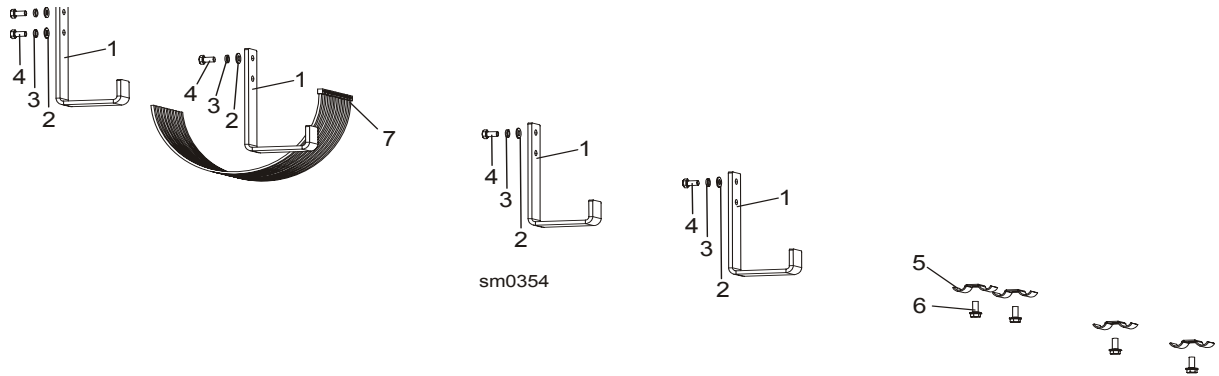

REF.	DESCRIPTION (◆ Indicates Parts Available In Assemblies Only)	PART #	QTY.	
	HANGER KIT, MBX24 (AH1-3) HYDRAULIC HOSE	506100	1	
1	HANGER, HYDRAULIC HOSE	505745	4	
2	WASHER, 8.4 FLAT ZINC	F81054-1	5	
3	WASHER, 8.2 SPLIT LOCK ZINC	F81054-4	5	
4	BOLT, M8x16 -8.8-B HEX HEAD FULL THREAD ZINC	F81002-20	5	
5	PLATE, 1/4" HOSE CLAMP	S09245	4	
6	SCREW, 5/16-18 x 3/4 SELF-TAPPING	F05015-30	4	
7	WRAP, TKUV 50/8 TIE	F81082-3	10	

7.2 Hydraulic Hose Hanger Kit, MBX24 Bed Extension (AH4-7)

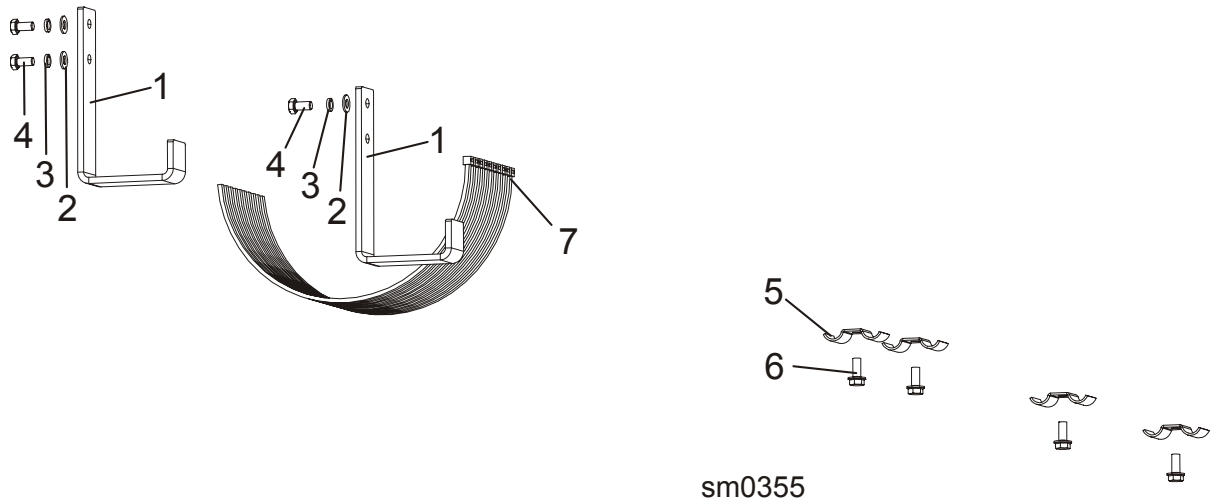

sm0355

REF.	DESCRIPTION (◆ Indicates Parts Available In Assemblies Only)	PART #	QTY.
	HANGER KIT, MBX24 (AH4-7) HYDRAULIC HOSE	505653	1
1	HANGER, HYDRAULIC HOSE	505745	2
2	WASHER, 8.4 FLAT ZINC	F81054-1	2
3	WASHER, 8.2 SPLIT LOCK ZINC	F81054-4	2
4	BOLT, M8x16 -8.8-B HEX HEAD FULL THREAD ZINC	F81002-20	2
5	PLATE, 1/4" HOSE CLAMP	S09245	4
6	SCREW, 5/16-18 x 3/4 SELF-TAPPING	F05015-30	4
7	WRAP, TKUV 50/8 TIE	F81082-3	10

7.3 Hydraulic Hose Kit, BX24 Bed Extension

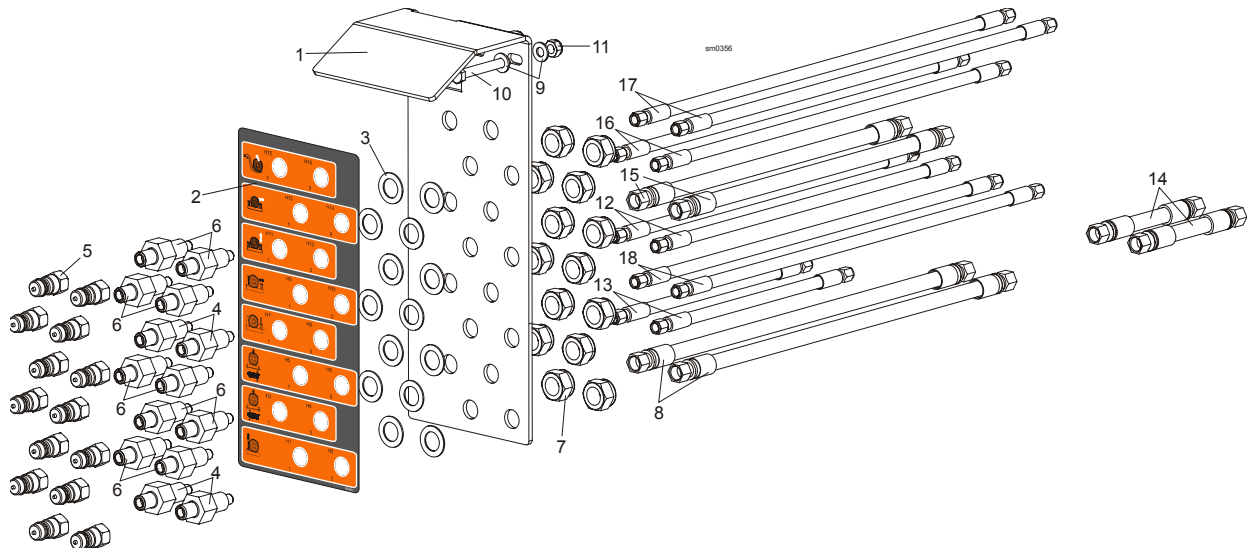

REF.	DESCRIPTION (◆ Indicates Parts Available In Assemblies Only)	PART #	QTY.
	HYDRAULIC HOSE KIT, BX24 24H1	505835	1
1	PLATE, QUICK DISCONNECT FITTING MOUNTING PTD	505887-1	1
2	DECAL, BX24 HYDRAULIC HOSE CONNECTION	505903	1
3	WASHER, 1940 DIA. (34/21.2/1.5)	506105	2
4	FITTING, Z3/8"BSP-Z9/16 UNF JIC REDUCER	504987-1	2
5	FITTING, 3/8" BSP MALE QUICK DISCONNECT	504966	2
7	NUT, M20-8-A HEX NYLON ZINC LOCK	F81037-2	2
8	HOSE, 2T3/8X4.80 W9/16UNF-W9/16UNF HYDRAULIC	505842	2
9	WASHER, 10.5 FLAT ZINC	F81055-1	4
10	BOLT, M10x75-8.8 HEX HEAD ZINC	F81003-15	2
11	NUT, M10-8-B HEX NYLON ZINC LOCK	F81033-1	2
	HYDRAULIC HOSE KIT, BX24 24H2	505837	1
1	PLATE, QUICK DISCONNECT FITTING MOUNTING PTD	505887-1	1
2	DECAL, BX24 HYDRAULIC HOSE CONNECTION	505903	1
3	WASHER, 1940 DIA. (34/21.2/1.5)	506105	4
4	FITTING, Z3/8"BSP-Z9/16 UNF JIC REDUCER	504987-1	2
5	FITTING, 3/8" BSP MALE QUICK DISCONNECT	504966	4
6	FITTING, 3/8" 7/16" UNF JIC REDUCER	504995-1	2
7	NUT, M20-8-A HEX NYLON ZINC LOCK	F81037-2	4
8	HOSE, 2T3/8X4.80 W9/16UNF-W9/16UNF HYDRAULIC	505842	2
9	WASHER, 10.5 FLAT ZINC	F81055-1	4
10	BOLT, M10x75-8.8 HEX HEAD ZINC	F81003-15	2
11	NUT, M10-8-B HEX NYLON ZINC LOCK	F81033-1	2
18	HOSE, 2T1/4X4.900 W7/16UNF-W7/16 UNF HYDRAULIC	097620	2
	HYDRAULIC HOSE KIT, BX24 24H3	505839	1
1	PLATE, QUICK DISCONNECT FITTING MOUNTING PTD	505887-1	1
2	DECAL, BX24 HYDRAULIC HOSE CONNECTION	505903	1

3	WASHER, 1940 DIA. (34/21.2/1.5)	506105	8
4	FITTING, Z3/8"BSP-Z9/16 UNF JIC REDUCER	504987-1	4
5	FITTING, 3/8" BSP MALE QUICK DISCONNECT	504966	8
6	FITTING, 3/8" 7/16" UNF JIC REDUCER	504995-1	4
7	NUT, M20-8-A HEX NYLON ZINC LOCK	F81037-2	8
8	HOSE, 2T3/8X4.80 W9/16UNF-W9/16UNF HYDRAULIC	505842	2
9	WASHER, 10.5 FLAT ZINC	F81055-1	4
10	BOLT, M10x75-8.8 HEX HEAD ZINC	F81003-15	2
11	NUT, M10-8-B HEX NYLON ZINC LOCK	F81033-1	2
12	HOSE, 2T1/4X4.8500 W7/16UNF-W7/16UNF HYDRAULIC	505844	2
15	HOSE, 2T3/8X3.750 W9/16UNF-W9/16UNF HYDRAULIC	505845	2
18	HOSE, 2T1/4X4.900 W7/16UNF-W7/16 UNF HYDRAULIC	097620	2
	HYDRAULIC HOSE KIT, BX24 24H4	505841	1
1	PLATE, QUICK DISCONNECT FITTING MOUNTING PTD	505887-1	1
2	DECAL, BX24 HYDRAULIC HOSE CONNECTION	505903	1
3	WASHER, 1940 DIA. (34/21.2/1.5)	506105	8
4	FITTING, Z3/8"BSP-Z9/16 UNF JIC REDUCER	504987-1	4
5	FITTING, 3/8" BSP MALE QUICK DISCONNECT	504966	8
6	FITTING, 3/8" 7/16" UNF JIC REDUCER	504995-1	4
7	NUT, M20-8-A HEX NYLON ZINC LOCK	F81037-2	8
8	HOSE, 2T3/8X4.80 W9/16UNF-W9/16UNF HYDRAULIC	505842	2
9	WASHER, 10.5 FLAT ZINC	F81055-1	4
10	BOLT, M10x75-8.8 HEX HEAD ZINC	F81003-15	2
11	NUT, M10-8-B HEX NYLON ZINC LOCK	F81033-1	2
12	HOSE, 2T1/4X4.8500 W7/16UNF-W7/16UNF HYDRAULIC	505844	2
14	HOSE, 2G3/8X0.690 W9/16UNF-W9/16UNF HYDRAULIC	014796	2
15	HOSE, 2T3/8X3.750 W9/16UNF-W9/16UNF HYDRAULIC	505845	2
18	HOSE, 2T1/4X4.900 W7/16UNF-W7/16 UNF HYDRAULIC	097620	2
	HYDRAULIC HOSE KIT, BX24 24H5	506091	1
1	PLATE, QUICK DISCONNECT FITTING MOUNTING PTD	505887-1	1
2	DECAL, BX24 HYDRAULIC HOSE CONNECTION	505903	1
3	WASHER, 1940 DIA. (34/21.2/1.5)	506105	12
4	FITTING, Z3/8"BSP-Z9/16 UNF JIC REDUCER	504987-1	4
5	FITTING, 3/8" BSP MALE QUICK DISCONNECT	504966	12
6	FITTING, 3/8" 7/16" UNF JIC REDUCER	504995-1	8
7	NUT, M20-8-A HEX NYLON ZINC LOCK	F81037-2	12
8	HOSE, 2T3/8X4.80 W9/16UNF-W9/16UNF HYDRAULIC	505842	2
9	WASHER, 10.5 FLAT ZINC	F81055-1	4
10	BOLT, M10x75-8.8 HEX HEAD ZINC	F81003-15	2
11	NUT, M10-8-B HEX NYLON ZINC LOCK	F81033-1	2
12	HOSE, 2T1/4X4.8500 W7/16UNF-W7/16UNF HYDRAULIC	505844	2
14	HOSE, 2G3/8X0.690 W9/16UNF-W9/16UNF HYDRAULIC	014796	2
15	HOSE, 2T3/8X3.750 W9/16UNF-W9/16UNF HYDRAULIC	505845	2
16	HOSE, 2T1/4X5.500 W7/16UNF-W7/16UNF HYDRAULIC	506094	2
17	HOSE, 2T1/4X5.900 W7/16UNF-W7/16UNF HYDRAULIC	506999	2
18	HOSE, 2T1/4X4.900 W7/16UNF-W7/16 UNF HYDRAULIC	097620	2

	HYDRAULIC HOSE KIT, BX24 24H6	506093	1	
1	PLATE, QUICK DISCONNECT FITTING MOUNTING PTD	505887-1	1	
2	DECAL, BX24 HYDRAULIC HOSE CONNECTION	505903	1	
3	WASHER, 1940 DIA. (34/21.2/1.5)	506105	14	
4	FITTING, Z3/8"BSP-Z9/16 UNF JIC REDUCER	504987-1	4	
5	FITTING, 3/8" BSP MALE QUICK DISCONNECT	504966	14	
6	FITTING, 3/8" 7/16" UNF JIC REDUCER	504995-1	10	
7	NUT, M20-8-A HEX NYLON ZINC LOCK	F81037-2	14	
8	HOSE, 2T3/8X4.80 W9/16UNF-W9/16UNF HYDRAULIC	505842	2	
9	WASHER, 10.5 FLAT ZINC	F81055-1	4	
10	BOLT, M10x75-8.8 HEX HEAD ZINC	F81003-15	2	
11	NUT, M10-8-B HEX NYLON ZINC LOCK	F81033-1	2	
12	HOSE, 2T1/4X4.8500 W7/16UNF-W7/16UNF HYDRAULIC	505844	2	
13	HOSE, 2T1/4X2.900 W7/16UNF-W7/16UNF HYDRAULIC	505843	2	
14	HOSE, 2G3/8X0.690 W9/16UNF-W9/16UNF HYDRAULIC	014796	2	
15	HOSE, 2T3/8X3.750 W9/16UNF-W9/16UNF HYDRAULIC	505845	2	
16	HOSE, 2T1/4X5.500 W7/16UNF-W7/16UNF HYDRAULIC	506094	2	
17	HOSE, 2T1/4X5.900 W7/16UNF-W7/16UNF HYDRAULIC	506999	2	
18	HOSE, 2T1/4X4.900 W7/16UNF-W7/16 UNF HYDRAULIC	097620	2	

7.4 Hydraulic Control Box, 16-Section LT20/40/70 AC

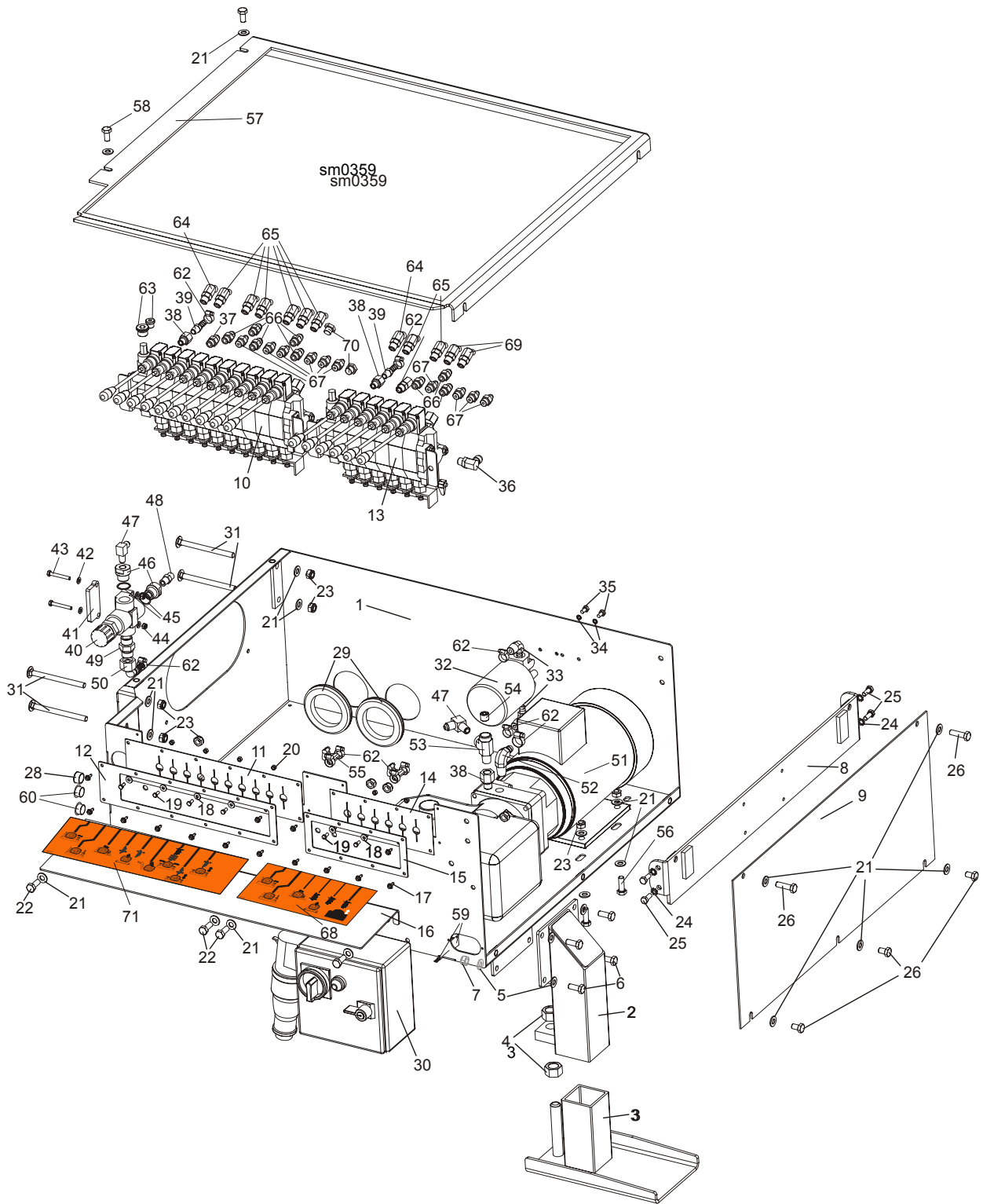

REF.	DESCRIPTION (◆ Indicates Parts Available In Assemblies Only)	PART #	QTY.	
	BOX, LT40/70 AC 16-SECTION HYDRAULIC CONTROL - COMPLETE	505945	1	
	BOX, LT20 AC 16-SECTION HYDRAULIC CONTROL - COMPLETE	505950	1	
1	BOX WELDMENT, HYDRAULIC CONTROL PTD	505946-1	1	
	LEG, HYDRAULIC CONTROL BOX	505741	1	
2	LEG, HYDRAULIC CONTROL BOX - UPPER PART	505742-1	1	
3	WIDE FOOT - ADJUSTABLE LEGS	501084-1	1	
4	NUT, M20-8 HEX ZINC	F81037-1	2	
5	WASHER, 10.5 FLAT ZINC	F81055-1	8	
6	BOLT, M10x25-8.8 HEX HEAD FULL THREAD ZINC	F81003-11	4	
7	NUT, M10-8-B HEX NYLON ZINC LOCK	F81033-1	4	
8	BRACKET, AC HYDRAULIC CONTROL BOX - COMPLETE	086518-1	1	
9	COVER, AC HYDRAULIC PUMP HOUSING SIDE	086484-1	1	
10	VALVE, HDS11/10 8-SECTION HYDRAULIC	091344	1	
11	GUARD, 10-SECTION HYDRAULIC VALVE RUBBER	091739	1	
12	COVER, 10-SECTION VALVE GUARD PTD	091826-1	1	
13	VALVE, 6-SPOOL FOR SERIES CONNECTION	501104	1	
14	GUARD, RUBBER DOUBLE VALVE	015079	1	
15	COVER, VALVE GUARD PTD	086519-1	1	
16	PLATE FOR DECALS	505949-1	1	
17	SCREW, #10-24x1/2 SELF-TAPPING	F05015-7	14	
18	WASHER, 5.5 SPECIAL FLAT ZINC-PL.	F81052-3	6	
19	BOLT, M5x12-5.8 HEX HEAD FULL THREAD ZINC	F81000-5	6	
20	NUT, M5-8 HEX ZINC	F81030-1	6	
21	WASHER, 10.5 FLAT ZINC	F81055-1	23	
22	BOLT, M10x25-8.8 HEX HEAD FULL THREAD ZINC	F81003-11	4	
23	NUT, M10-8-B HEX NYLON ZINC LOCK	F81033-1	12	
24	WASHER, 8.4 EXTERIOR STAR LOCK	F81054-3	4	
25	BOLT, M8x20-8.8-B HEX HEAD FULL THREAD ZINC	F81002-4	4	
26	BOLT, M10x16-8.8 HEX HEAD FULL THREAD ZINC	F81003-13	3	
27	BOLT, M10x35-8.8 HEX HEAD FULL THREAD ZINC	F81003-17	2	
28	GROMMET, HEYCO WIRE	P04137	1	
29	GROMMET, 80MM DIA. RUBBER	089293	2	
30	BOX, AC 4kW STARTER	089799 ¹	1	
	BOX, LT20 STARTER	093088 ²	1	
	BOX, LT20 STARTER - NORWAY	093088-2 ³	1	
31	BOLT, M10x125 8.8 CARRIAGE HEAD ZINC	F81003-34	4	
32	MANIFOLD W/FILTER	P22683	1	
33	FITTING, (1/2"NPT)-3/8" ELBOW	P12707	2	
34	WASHER, Z 6.1 SPLIT LOCK ZINC	F81053-3	2	
35	BOLT, 1/4-20x1/2" HEX HEAD ZINC GRADE 2	F05005-15	2	
36	FITTING, #6 SAE 3/8"JIC ELBOW	P12704	1	
37	FITTING, 3/8JIC -3/8 O-RING	014687	1	
38	FITTING, 6SAE MALE-1/4NPT FEMALE	014686	3	
39	FITTING, 1/4NPT-3/8 BARB	014685	2	
40	VALVE, MTKA.VB OIL FLOW CONTROL	093794	1	

41	PLATE, MTKA VALVE ZINC-PL. SPACER	094477-1	1	
42	WASHER, 6.4 FLAT ZINC	F81053-1	4	
43	BOLT, M6x45-8.8 HEX HEAD ZINC	F81001-6	2	
44	NUT, M6-8-B HEX NYLON ZINC LOCK	F81031-2	2	
45	WASHER, 22 COPPER	F81061-5	2	
46	FITTING, M22x1.5 / 1/4 -18 NPT ZINC-PL. REDUCER	093139-1	2	
47	FITTING, 3/8JIC-1/4NPT 90L	015491	2	
48	FITTING, 3/8JIC-1/4NPT STRAIGHT	015560	1	
49	FITTING, VMNW10HS22	094486	1	
50	FITTING, PN10AFL 13-90 ELBOW	094485	1	
51	HYDRAULIC PUMP, AC.4KW 14.5L/MIN W/MOTOR	500958	1	
52	FITTING, #6-6(3/8"NPT)-3/8" ELBOW	P12708	1	
53	FITTING, 1/4NPT MALE RUN TEE	P09141	1	
54	PLUG, TN 192-1/4NPT	096221	1	
55	FITTING, 3/8 BARB TEE	015485	2	
56	BOLT, M10x30-5.8 HEX HEAD FULL THREAD ZINC	F81003-2	4	
57	COVER, HYDRAULIC CONTROL BOX	505948-1	1	
58	BOLT, M10x20-5.8 HEX HEAD FULL THREAD ZINC	F81003-1	2	
59	SWITCH, 2A 125V R-LEVER NO/NC/COM	014765	1	
60	CAP, 1086 DIA. 22.2 DIA. HOLE	093544	2	
61	FITTING, 45 DEG. #6SAE ELBOW	015489	1	
62	CLAMP, 11/16 HOSE	061807	12	
63	PLUG KIT FOR BOX #500508	505060	1	
64	FITTING, 45 DEG. #6SAE ELBOW	015489	*	
65	FITTING, #4SAE-#6SAE 45 DEG. ELBOW	015488	*	
66	FITTING, 3/8JIC -3/8 O-RING	014687	*	
67	FITTING, 1/4JIC-3/8 O-RING	P26284	*	
68	DECAL, 24H1-6 FOR 16-SECTION BOX	505961	1	
69	FITTING, #4SAE-#6SAE 45 DEG. ELBOW	015488	*	
70	PLUG, 9/16-18 JIC HYDRAULIC VALVE	089647	*	
71	DECAL FOR AH5/16-SECTION BOX	506099	1	

¹ Included in assembly #505945 (LT40/70)

² Included in assembly #505950 (LT20)

³ Included in assembly #505950 (LT20)

* Depends on hydraulic equipment configuration.

7.5 Hydraulic Control Box, LT20/40/70 AC 10-Section

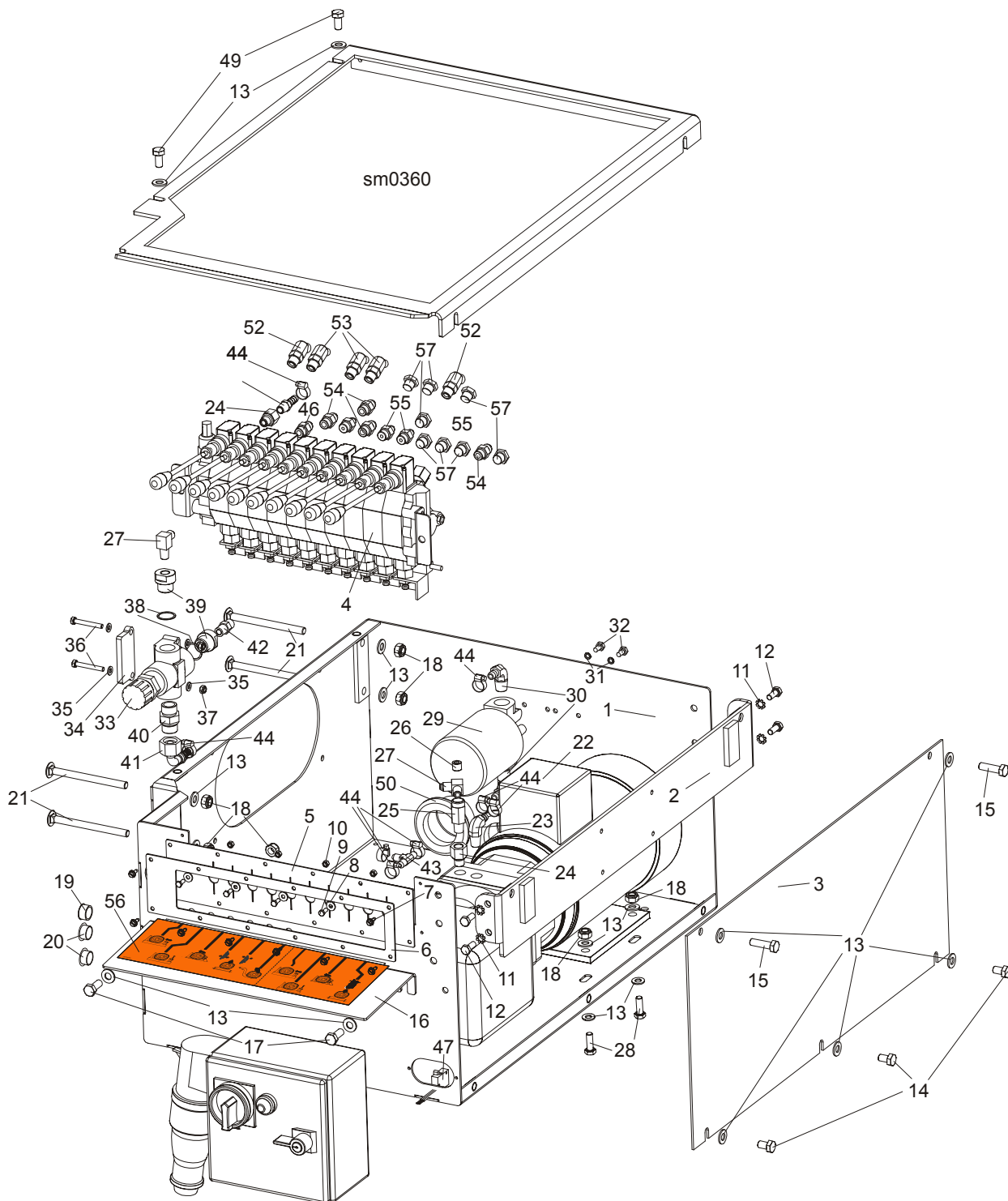

REF.	DESCRIPTION (◆ Indicates Parts Available In Assemblies Only)	PART #	QTY.
	HYDRAULIC CONTROL BOX, LT40/70AC BX24 10-SECTION - COMPLETE	506446	1
	HYDRAULIC CONTROL BOX, LT20 AC BX24 10-SECTION	506555	1

1	BOX WELDMENT, HYDRAULIC CONTROL PTD	091729-1	1	
2	BRACKET, AC HYDRAULIC CONTROL BOX - COMPLETE	086518-1	1	
3	COVER, AC HYDRAULIC PUMP HOUSING SIDE	086484-1	1	
4	VALVE, HDS11/10 8-SECTION HYDRAULIC	091344	1	
5	GUARD, 10-SECTION HYDRAULIC VALVE RUBBER	091739	1	
6	COVER, 10-SECTION VALVE GUARD PTD	091826-1	1	
7	SCREW, #10-24x1/2 SELF-TAPPING	F05015-7	8	
8	WASHER, 5.5 SPECIAL FLAT ZINC-PL.	F81052-3	4	
9	BOLT, M5x12-5.8 HEX HEAD FULL THREAD ZINC	F81000-5	4	
10	NUT, M5-8 HEX ZINC	F81030-1	4	
11	WASHER, 8.4 EXTERIOR STAR LOCK	F81054-3	4	
12	BOLT, M8x20-8.8-B HEX HEAD FULL THREAD ZINC	F81002-4	4	
13	WASHER, 10.5 FLAT ZINC	F81055-1	21	
14	BOLT, M10x16-8.8 HEX HEAD FULL THREAD ZINC	F81003-13	3	
15	BOLT, M10x35-8.8 HEX HEAD FULL THREAD ZINC	F81003-17	2	
16	PLATE, DECAL PTD	506588-1	1	
17	BOLT, M10x25-8.8 HEX HEAD FULL THREAD ZINC	F81003-11	2	
18	NUT, M10-8-B HEX NYLON ZINC LOCK	F81033-1	10	
19	GROMMET, HEYCO WIRE	P04137	1	
20	CAP, 1086 DIA. 22.2 DIA. HOLE	093544	2	
21	BOLT, M10x125 8.8 CARRIAGE HEAD ZINC	F81003-34	4	
22	HYDRAULIC PUMP W/MOTOR, AC.4KW 14.5L/MIN	500958	1	
23	FITTING, #6-6(3/8"NPT)-3/8" ELBOW	P12708	1	
24	FITTING, 6SAE MALE-1/4NPT FEMALE	014686	2	
25	FITTING, 1/4NPT MALE RUN TEE	P09141	1	
26	PLUG, TN 192-1/4NPT	096221	1	
27	FITTING, 3/8JIC-1/4NPT 90L	015491	2	
28	BOLT, M10x30-5.8 HEX HEAD FULL THREAD ZINC	F81003-2	4	
29	MANIFOLD W/FILTER	P22683	1	
30	FITTING, (1/2"NPT)-3/8" ELBOW	P12707	2	
31	WASHER, Z 6.1 SPLIT LOCK ZINC	F81053-3	2	
32	BOLT, 1/4-20x1/2" HEX HEAD ZINC GRADE 2	F05005-15	2	
33	VALVE, MTKA.VB OIL FLOW CONTROL	093794	1	
34	PLATE, MTKA VALVE ZINC-PL. SPACER	094477-1	1	
35	WASHER, 6.4 FLAT ZINC	F81053-1	4	
36	BOLT, M6x45-8.8 HEX HEAD ZINC	F81001-6	2	
37	NUT, M6-8-B HEX NYLON ZINC LOCK	F81031-2	2	
38	WASHER, 22 COPPER	F81061-5	2	
39	FITTING, M22x1.5 / 1/4 -18 NPT ZINC-PL. REDUCER	093139-1	2	
40	FITTING, VMNW10HS22	094486	1	
41	FITTING, PN10AFL 13-90 ELBOW	094485	1	
42	FITTING, 3/8JIC-1/4 NPT STRAIGHT	015560	1	
43	FITTING, 3/8 BARB TEE	015485	2	
44	CLAMP, 11/16 HOSE	061807	8	
45	FITTING, 1/4NPT-3/8 BARB	014685	1	
46	FITTING, 3/8JIC -3/8 O-RING	014687	1	

47	SWITCH, 2A 125V R-LEVER NO/NC/COM	014765	1	
48	COVER, HYDRAULIC CONTROL BOX	506587-1	1	
49	BOLT, M10x20-5.8 HEX HEAD FULL THREAD ZINC	F81003-1	2	
50	GROMMET, 55mm DIA. RUBBER	085614	2	
51	BOX, AC 4kW STARTER	089799 ¹	1	
	BOX, LT20 STARTER	093088 ²	1	
	BOX, LT20 STARTER - NORWAY	093088-2 ³	1	
52	FITTING, 45 DEG. #6SAE ELBOW	015489	*	
53	FITTING, #4SAE-#6SAE 45 DEG. ELBOW	015488	*	
54	FITTING, 3/8JIC -3/8 O-RING	014687	*	
55	FITTING, 1/4JIC-3/8 O-RING	P26284	*	
56	DECAL, 24H1-6 FOR 16-SECTION BOX	506589	1	
57	PLUG, 9/16-18 JIC HYDRAULIC VALVE	089647	*	

¹ Included in assembly #506446 (LT40/70)

² Included in assembly #506555 (LT20)

³ Included in assembly 506555 (LT20)

* Depends on hydraulic equipment configuration.