

Bed Extension

Safety, Operation, Maintenance & Parts Manual

BX6 for 2004+ Sawmills	Rev. A1.01
BX12 for 2004+ Sawmills	Rev. A1.01
BX24 for 2004+ Sawmills	Rev. A1.01



Safety is our #1 concern! Read and understand all safety information and instructions before operating, setting up or maintaining this machine.

April 2004

Form #295

Table of Contents

Section-Page

SECTION 1	INSTALLATION	1-1
1.1	Alignment Box Installation	1-2
1.2	Leg Installation.....	1-4
1.3	Extension Frame Attachment	1-6
1.4	Support Brace Installation	1-9
1.5	Extra Leg and Bed Rail Installation (24-foot Bed Extensions Only).....	1-11
SECTION 2	BED EXTENSION ALIGNMENT	2-1
SECTION 3	LOG CLAMP OPERATION	3-1
SECTION 4	STORAGE PROTECTION	4-1
SECTION 5	BED EXTENSION PARTS	5-1
5.1	Bed Rail Assembly, Front And Rear (BX6 Only).....	5-1
5.2	Bed Rail Assembly, Front And Rear (BX12/24 Only).....	5-2
5.3	Bed Rail Assembly, Front Middle (BX12/24 Only) and Rear Middle (BX24 Only).....	5-3
5.4	Bed Rail Assembly, Rear Middle (BX12 Only).....	5-4
5.5	Pivot Bed Rail Assembly (BX24 Only)	5-5
5.6	Pivot Bed Rail Assembly (BX12 Only)	5-6
5.7	Auxiliary Bed Rail Assembly (BX24 Only)	5-7
5.8	Log Side Support Assembly	5-8
5.9	20 in. M Bed Extension/ Alignment Box/ Feed Chain.....	5-10
5.10	Stationary Legs.....	5-12
5.11	Stationary Legs, Middle Short (BX24 Only)	5-13
5.12	Main Bed Tube Outrigger Leg	5-14
5.13	Side FAO Leg.....	5-15
5.14	Log Clamp/Winch Cable Pulley.....	5-16
5.15	Brace Kit, SBX6.....	5-17
5.16	Brace Kit, MBX6.....	5-18
5.17	Brace Kit, LBX6.....	5-19
5.18	Brace Kit, SBX12.....	5-20
5.19	Brace Kit, MBX12.....	5-21
5.20	Brace Kit, LBX12.....	5-22
5.21	Brace Kit, SBX24.....	5-23
5.22	Brace Kit, MBX24.....	5-24
5.23	Bed Extension, MBX6 Super	5-25
5.24	Bed Extension, MBX12 Super	5-26
5.25	Bed Extension, MBX24 Super	5-27

SECTION 1 INSTALLATION

The bed extension option includes a 6, 12 or 24-foot frame and the necessary hardware to attach it to your sawmill. After installation, the extension will allow you to cut longer logs than is possible with the standard sawmill. The bed extension is designed for operation with a stationary sawmill. A portable mill can be connected to the extension but will require 2 to 4 hours for each setup. The extension should be mounted to a firm, level footing. See [Form #359PL](#) located in the back of this manual for foot dimensions for each sawmill model and bed extension combination. Note the positions labeled A through E on each drawing. These positions will be referred to later for mounting the legs to the extension frame. Positions F, G, H and I apply to 24-foot extensions only.

1.1 Alignment Box Installation

1. Remove the feed chain from the tensioner bolt at the back end of the sawmill frame. Break apart the master link to disconnect the chain from the bolt.



CAUTION! When removing or replacing the feed chain on sawmills with hydraulic log handling, disconnect the negative battery lead. This will ensure the chain does not short the system if it contacts the power supply.

See Figure 1-1.

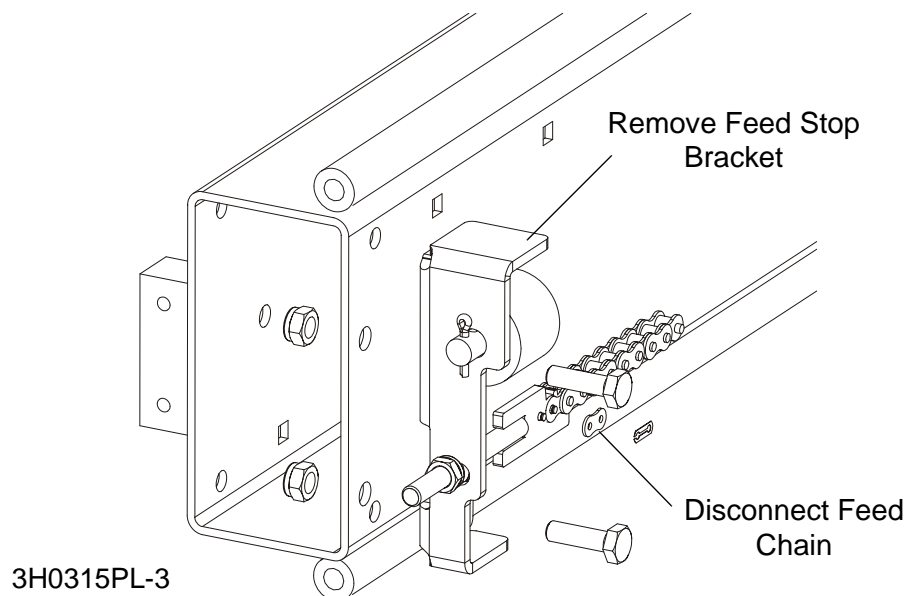

FIG. 1-1

2. Remove the bolts and lock nuts holding the feed chain tensioner to the sawmill frame. Remove the entire assembly from the sawmill frame. Use the same bolts and nuts to remount the tensioner assembly to the end of the extension frame.

3. Install the alignment link inside the end of the bed extension frame using the appropriate holes. Use four M10x115 hex head bolts and 10.5 flat washers to secure the box.

See Figure 1-2.

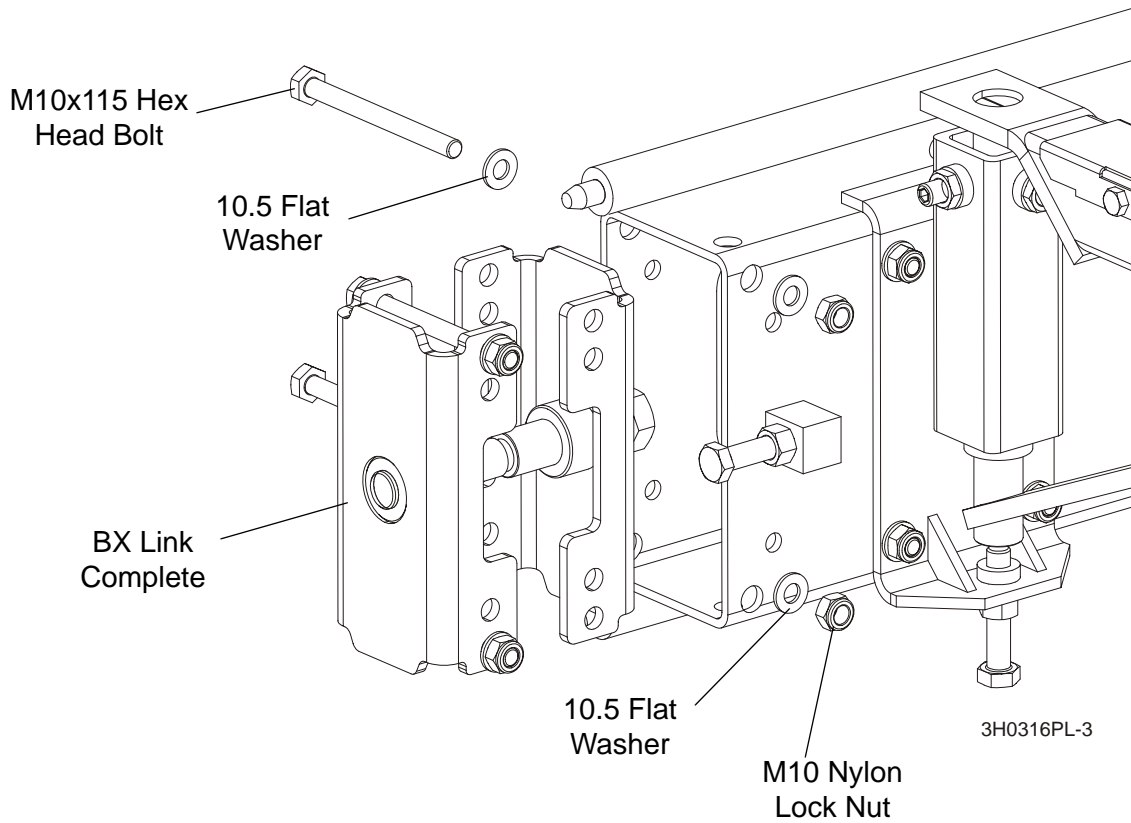

FIG. 1-2

1.2 Leg Installation

REMINDER: This section refers to positions A through E as labeled in [Form #359PL](#) located in the back of this manual.

1. Remove the rear leg (or outrigger) from position E on the sawmill frame. A support brace will be installed later that connects the extension frame to the sawmill frame. The removed sawmill leg will be repositioned on the support brace.

See Figure 1-3.

2. Use four M10 x 120 bolts and nylon lock nuts to secure a long leg at each position A and B on the extension frame. Insert the bolts from the outside of the frame tube and attach the nuts on the leg side of the tube.
3. **BX24 only:** Install a long leg at position H using four M10 x 25 bolts and nylon lock nuts.

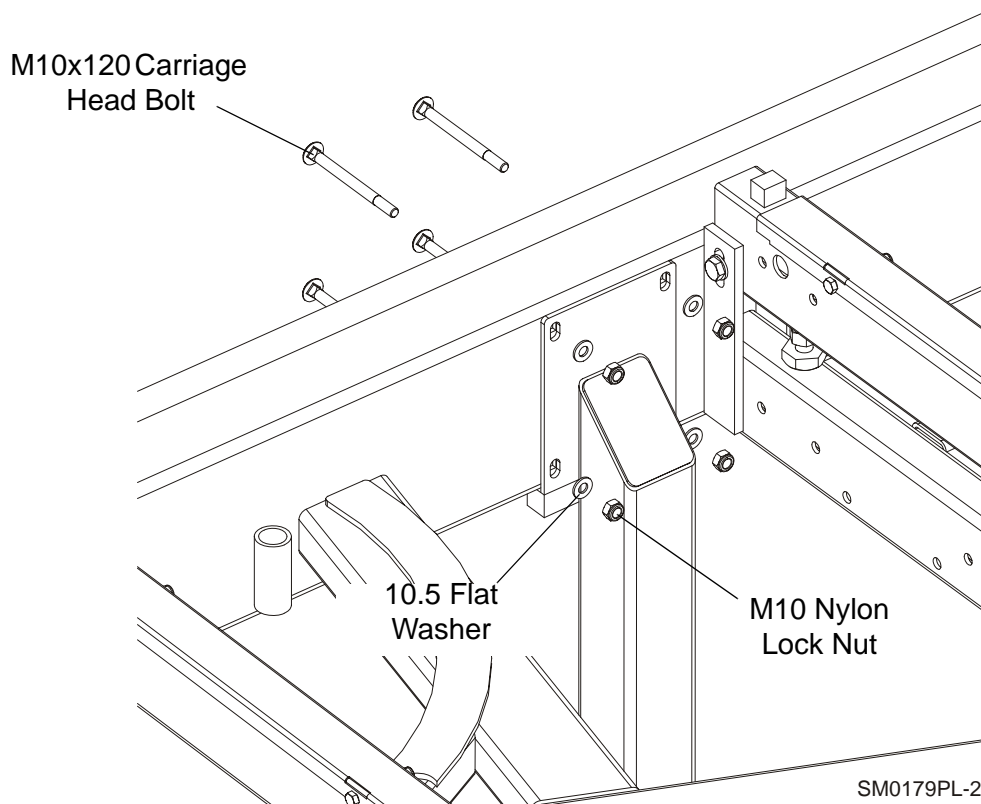

FIG. 1-3

4. Use four M10 x 25 bolts and nylon lock nuts to mount a short leg at position C on the extension frame.

See Figure 1-4.

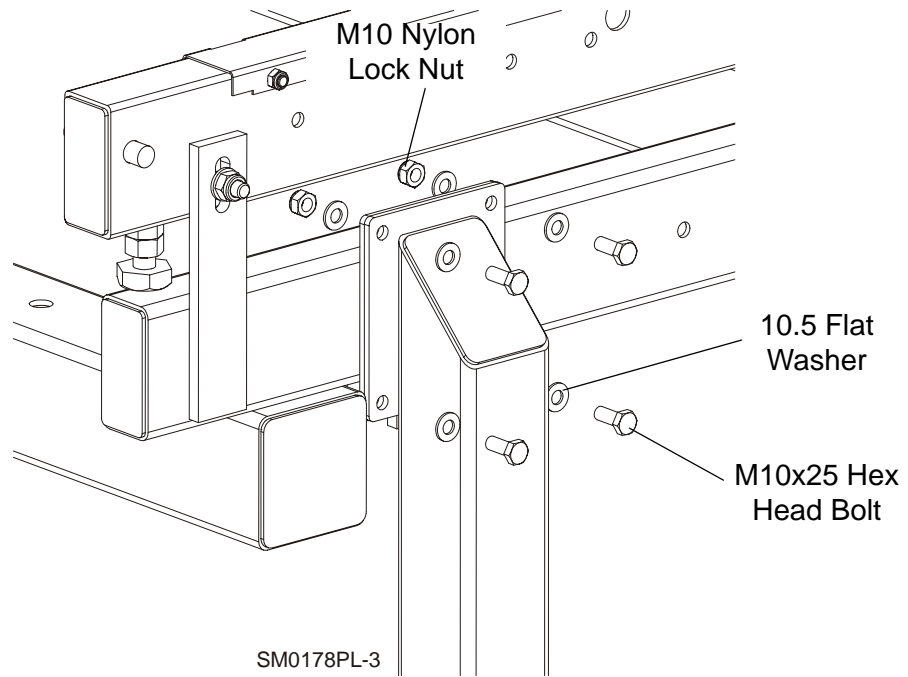

FIG. 1-4

1.3 Extension Frame Attachment

1. Position the extension frame at the end of the sawmill frame. Remove two bolts and nuts from the alignment link and loosen the jam nut. Turn the alignment link bolt counterclockwise to move the front plate towards as much as possible. Slide the extension frame over the alignment link on the sawmill frame. Sight down the length of the frames to see that they are lined up as close as possible.

See Figure 1-5.

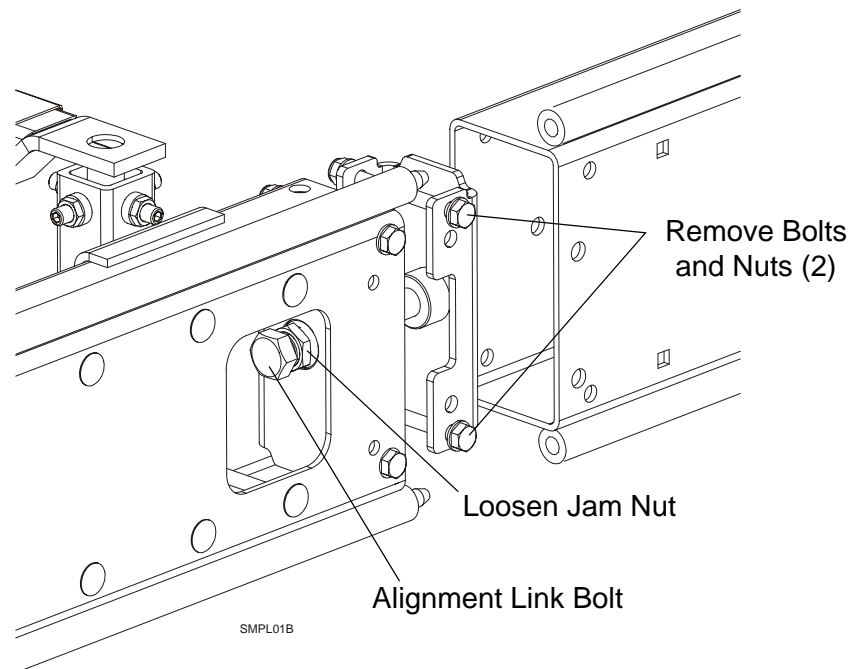

FIG. 1-5

2. Install two M10 X 115 hex head bolts in the holes together with four 10.5 flat washers. Secure the bolts with two M10-8 nylon lock hex nuts.

See Figure 1-6.

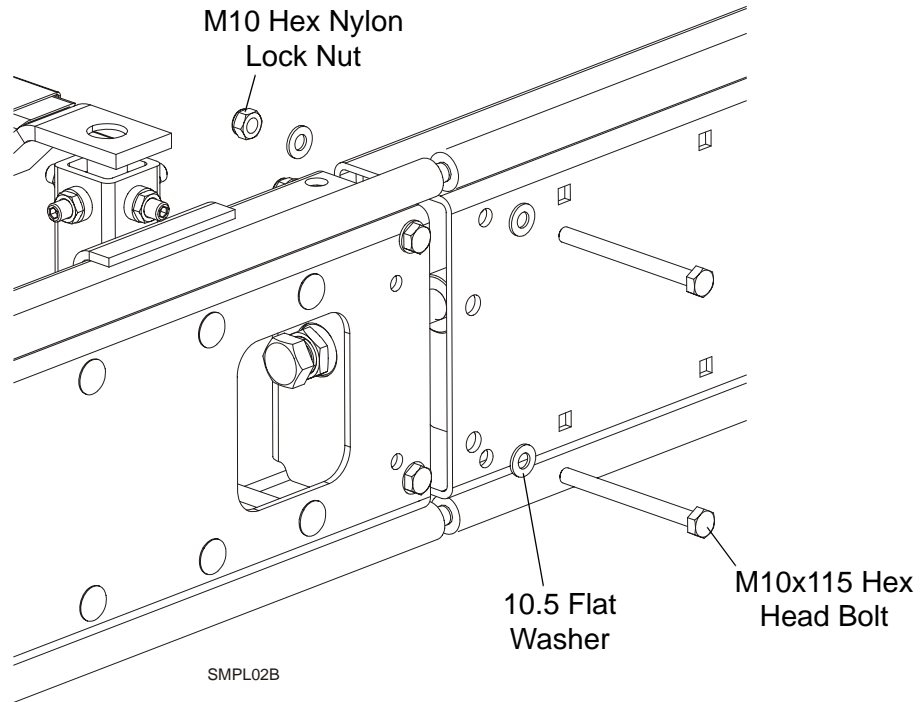

FIG. 1-6

3. Turn the alignment link bolt clockwise to tighten the bed extension and sawmill frame tubes.

See Figure 1-7.

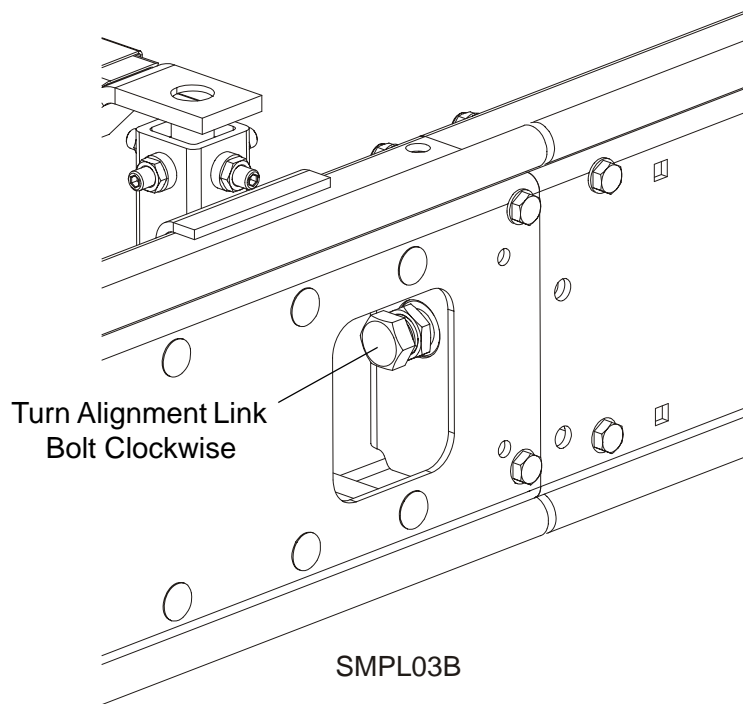

FIG. 1-7

4. Be sure to tighten the alignment link jam nut against the box when the attachment procedure is complete.

1.4 Support Brace Installation

See Table 1-1. A support brace is available to connect the bed extension and the sawmill. See the chart below to determine which brace you need for your configuration.

Bed Extension Support Brace Reference Table		
Sawmill Model	Bed-X	Brace Kit
1996+ LT30 or LT30HD	1996+ BX6	085651-1, 085653-1
	1996+ BX12	014271
	1996+ BX24	014273
1996+ LT40 or LT40HD	1996+ BX6	085651-1, 085656-1
	1996+ BX12	014270
	1996+ BX24	014272

TABLE 1-1

1. Mount the support brace tube between the sawmill and extension frames at positions D and E. Use four M10 x 25 bolts and lock nuts to secure the brace at position D and E.

See Figure 1-8.

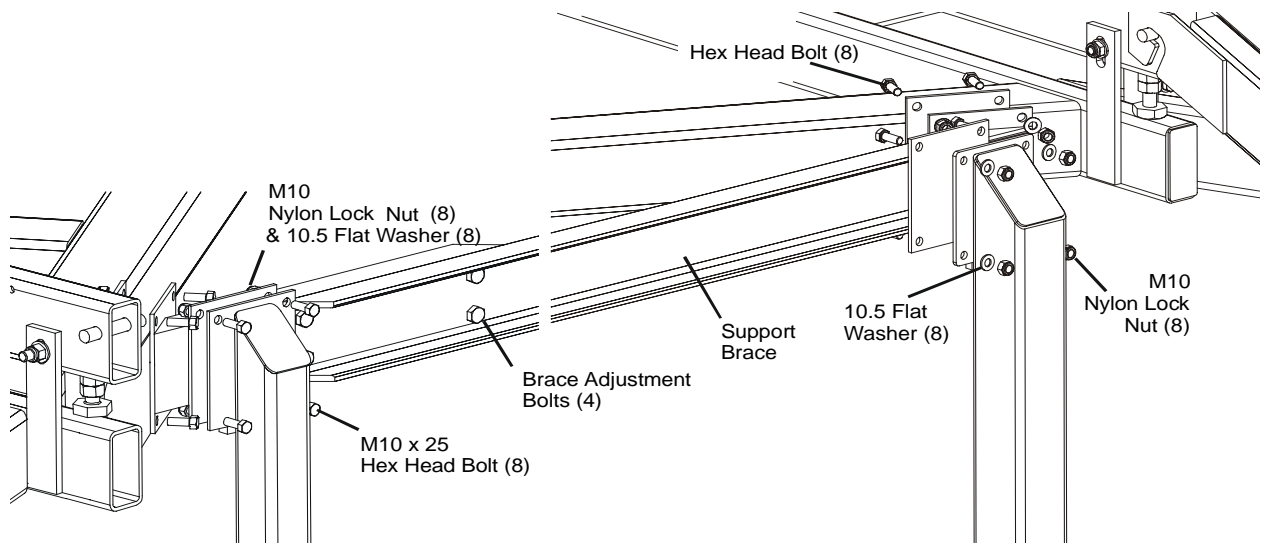

FIG. 1-8

2. Bolt the leg previously removed from the sawmill and a supplied short leg to the support brace tube with four M10 x 25 bolts and nylon lock nuts each.
3. Attach the supplied length of feed chain to the existing feed chain with the master link provided. Connect the feed chain to the tensioner bolt at the end of the extension frame. Adjust the tensioner so that the chain is positioned as indicated below. Make sure the

1**Installation***Support Brace Installation*

feed chain is not twisted or kinked.

BX Model	Distance from top of top track rail to top of feed chain (measure at middle of chain span)
BX6	7 - 8 inches
BX12	8 - 9 inches
BX24	10 - 11 inches

TABLE 1-1

1.5 Extra Leg and Bed Rail Installation (24-foot Bed Extensions Only)

1. The additional long leg should be mounted at position F shown in [Form #359PL](#). Use M10 x 120 bolts and lock nuts to secure the long leg to the main frame tube.

NOTE: When bolting near the end of the main tube, the tube can collapse or "mushroom" as the bolts are tightened. Do not overtighten the bolts to avoid deforming the main tube. If you find it difficult to align the tracks with the alignment set screws, check that neither frame tube is deformed. The tube can be pulled back into shape using the alignment set screws.

See Figure 1-9.

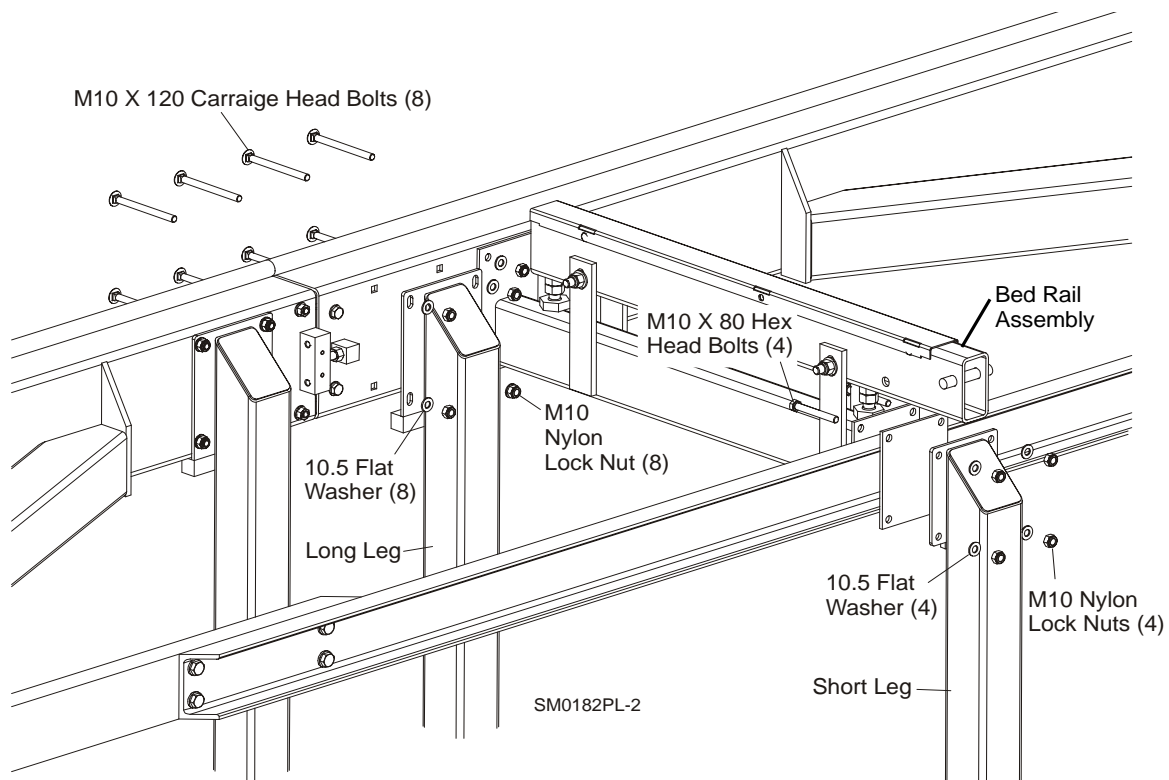

FIG. 1-9

2. Mount the additional bed rail assembly and short leg at position G on the support brace tube. Use bolts and lock nuts to mount the short leg and bed rail to the support brace tube. Use M10 x 120 bolts and lock nuts to mount the other end of the bed rail to the main tube.

1

Installation

Extra Leg and Bed Rail Installation (24-foot Bed Extensions Only)

3. Mount two middle short legs at position I shown in [Form #359PL](#). Use four M12 X 30 hex head bolts.

See Figure 1-10.

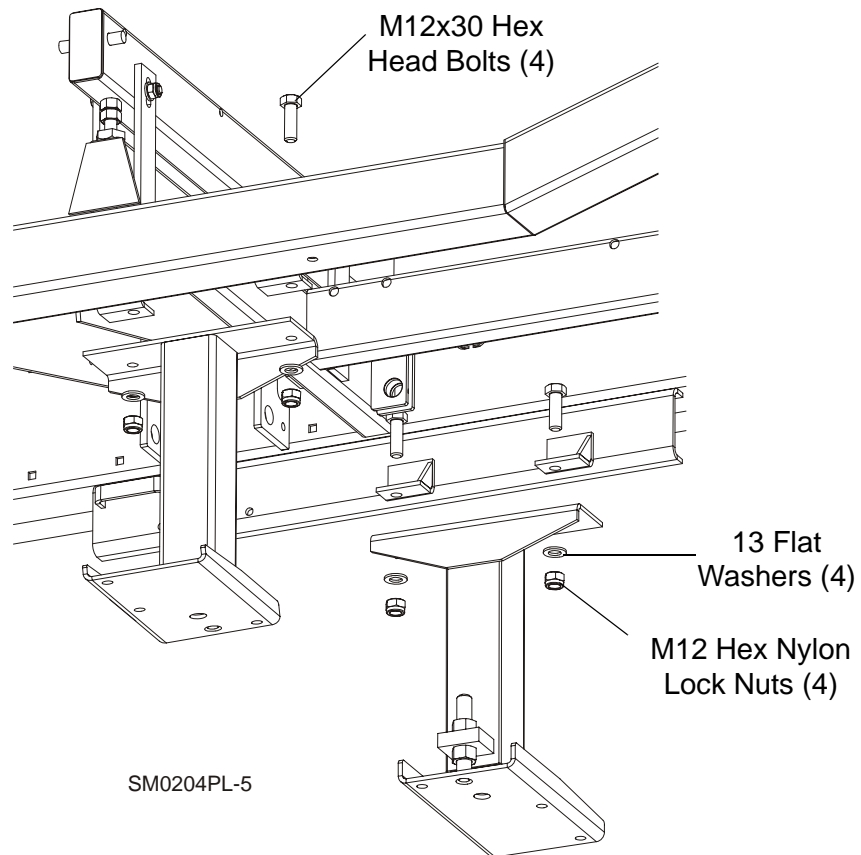

FIG. 1-10

SECTION 2 BED EXTENSION ALIGNMENT

1. Use the six set screws around the extension frame tube to align the upper and lower tracks on the sawmill to the tracks on the extension. You should not be able to detect any variance where one track ends and the other starts.
2. Move the cutting head across the area where the sawmill frame and extension meet. If the tracks are properly aligned, you should not be able to tell when the track bearings cross from the sawmill to the extension. Any variance will cause inaccurately sawn boards! Fine tune the set screws until the sawmill and extension tracks are perfectly matched.

NOTE: Bolting through the main tube can cause the tube to collapse or "mushroom". If you find it difficult to align the tracks with the alignment set screws, check that neither frame tube is deformed. The tube can be pulled back into shape using the alignment set screws.

3. Place two equal height objects on top of the track rail (wrench sockets work well). Pull a string tight over the objects and clamp so there is no sag in the string. Measure from the string to the track at one end, the middle, and the other end of the track. The track should be 1/16 to 1/8" (1.5 to 3.0 mm) higher in the middle than at the ends. This will compensate for any sag that occurs as the cutting head reaches the middle of the track. If more bow in the middle is needed, shim the middle track-mounted legs. If the middle is bowed up too much, shim the track-mounted legs at each end of the frame. Shim under any feet that do not touch the ground.
4. Align the sawmill and extension as instructed in your sawmill manual.

3 Log Clamp Operation

SECTION 3 LOG CLAMP OPERATION

A manual log clamp is supplied with the bed extension to help clamp long logs against the side supports.

1. Insert the log clamp post in the slotted channel between the middle bed rails of the extension. Choose a hole close to the log.
2. Pull the clamp handle to spin the cam against the log and clamp the log firmly against the side supports.
3. Lock the clamp in place with the chain mounted to the extension frame. Stretch the chain up to the clamp and slip the chain through the slot on the clamp handle. Use a link in the chain that holds the clamp firmly against the log.

SECTION 4 STORAGE PROTECTION

When not using the bed extension, follow the recommendations below to prevent rust and/or corrosion.

1. Coat the top and bottom bed extension rails with a rust inhibitor such as Sherwin-Williams P.D.R.P. #710.
2. Coat the power feed chain with a light film of a light-weight lubricant such as Dexron III ATF. Make sure the connecting link is attached to the chain to prevent chain loss.
3. Coat the threads of the bed rail leveling bolts with a dry lube such as Gunk L-508.
4. Lubricate the pivot block/shaft on the pivot bed rails with NLGI No. 2 grade lithium grease such as Amoco Rycon #2 Synthetic Grease.

Preparation For Use

Before using a bed extension that has been stored in the above manner, remove the rust inhibitor protection coat from the bed extension rails. Use a clean, dry cloth and a light lubricant such as WD-40 to remove the protection coat.

SECTION 5 BED EXTENSION PARTS

5.1 Bed Rail Assembly, Front And Rear (BX6 Only)

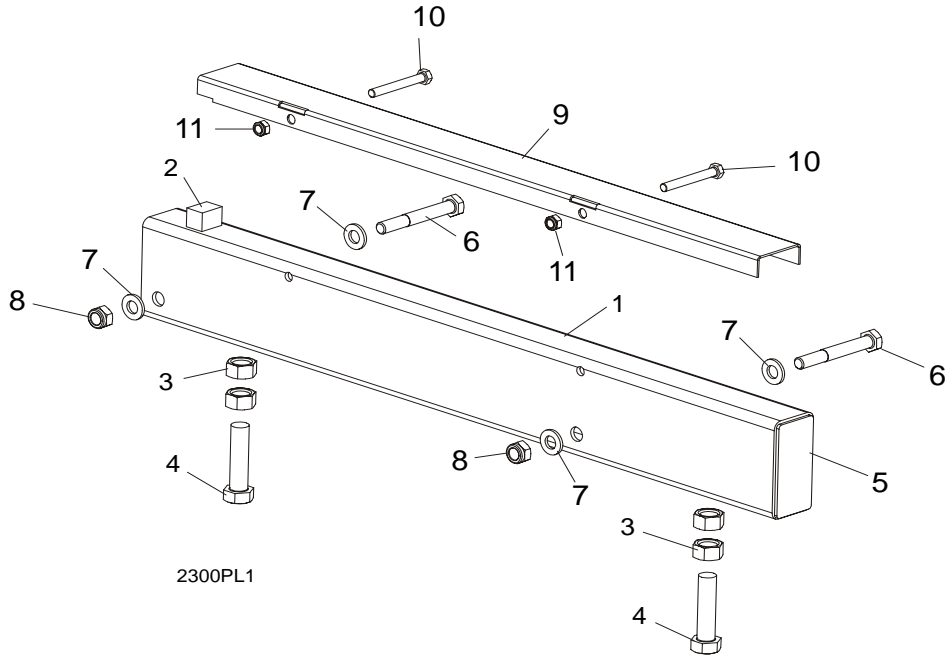

REF	DESCRIPTION (◆ Indicates Parts Available In Assemblies Only)	PART #	QTY.	
	BED RAIL ASSEMBLY	A09774	2	
1	Bed Rail Tube, Long	085469	1	◆
2	Block, Log Stop	S09034	1	
	Bolt Assembly, Bed Rail	A09775	2	◆
3	Nut, M16-5.8 Hex Zinc	F81036-1	4	
4	Bolt, M16 x 65-8.8-B Hex Head Full Thread Zinc	F81006-1	2	
5	Plate, Bed Rail End Cap	S04058	1	
6	BOLT, M12 X 90-8.8 HEX HEAD ZINC	F81004-2	4	
7	WASHER, 13 FLAT ZINC	F81056-1	8	
8	NUT, M12-8 HEX NYLON ZINC LOCK	F81034-2	4	
	COVER ASSEMBLY, STAINLESS STEEL BED RAIL (LONG)	A09956	2	
9	Cover, Stainless Steel Bed Rail	085464	1	◆
10	Bolt, M8 X 65 5.8 Hex Head Zinc	F81002-3	2	
11	Nut, M8-8-B Hex Nylon Zinc Lock	F81032-2	2	

5.2 Bed Rail Assembly, Front And Rear (BX12/24 Only)

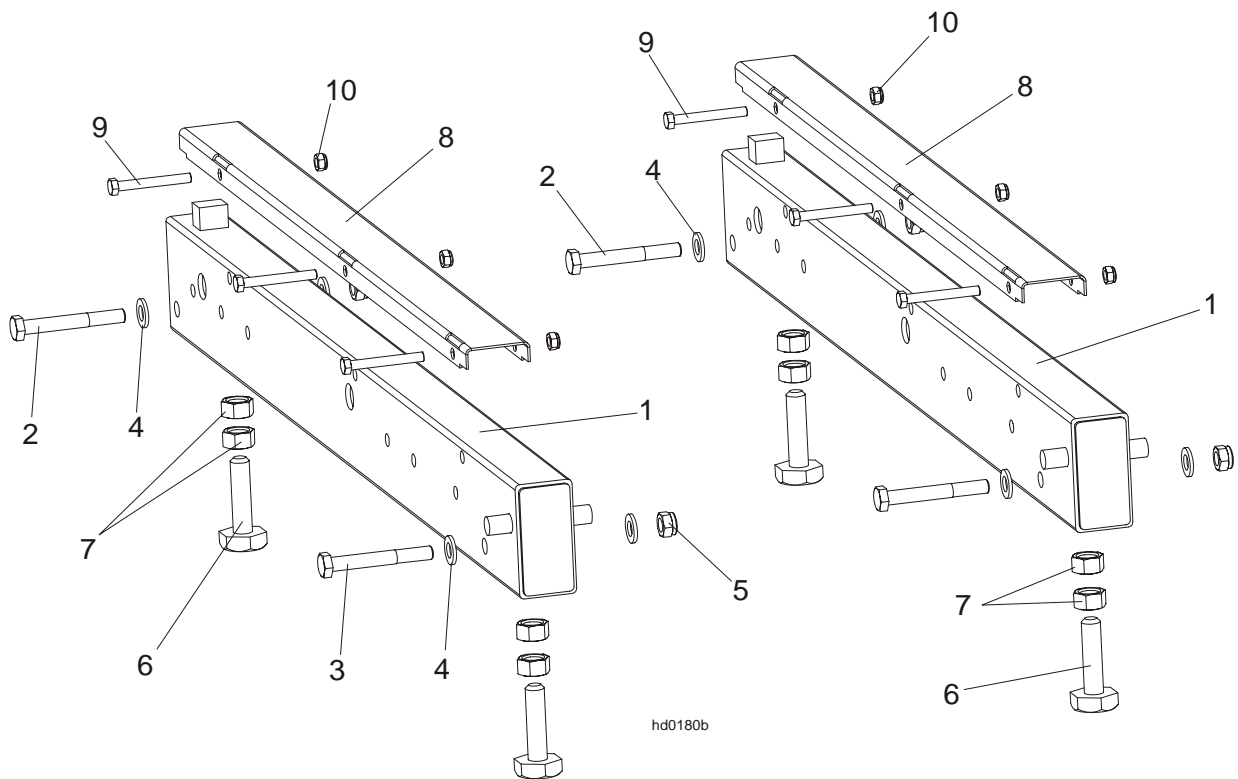

REF	DESCRIPTION (◆ Indicates Parts Available In Assemblies Only)	PART #	QTY.
1	BED RAIL ASSEMBLY, REAR PAINTED	091555	2
2	Bolt, M12 x 90-8.8 Hex Head Zinc	F81004-2	2
3	Bolt, M12 x 95-8.8 Hex Head Zinc	F81004-29	2
4	Washer, 13 Flat Zinc	F81056-1	8
5	Nut, M12-8 Hex Nylon Zinc Lock	F81034-2	4
6	Bolt, M16 Bed Rail Adjustment	505006	4
7	Nut, M16-5-B Hex	F81036-5	4
8	COVER, STAINLESS STEEL BED RAIL	099124	2
9	BOLT, M8X65-5.8 HEX HEAD ZINC	F81002-3	6
10	NUT, M8-8-B HEX NYLON ZINC LOCK	F81032-2	6

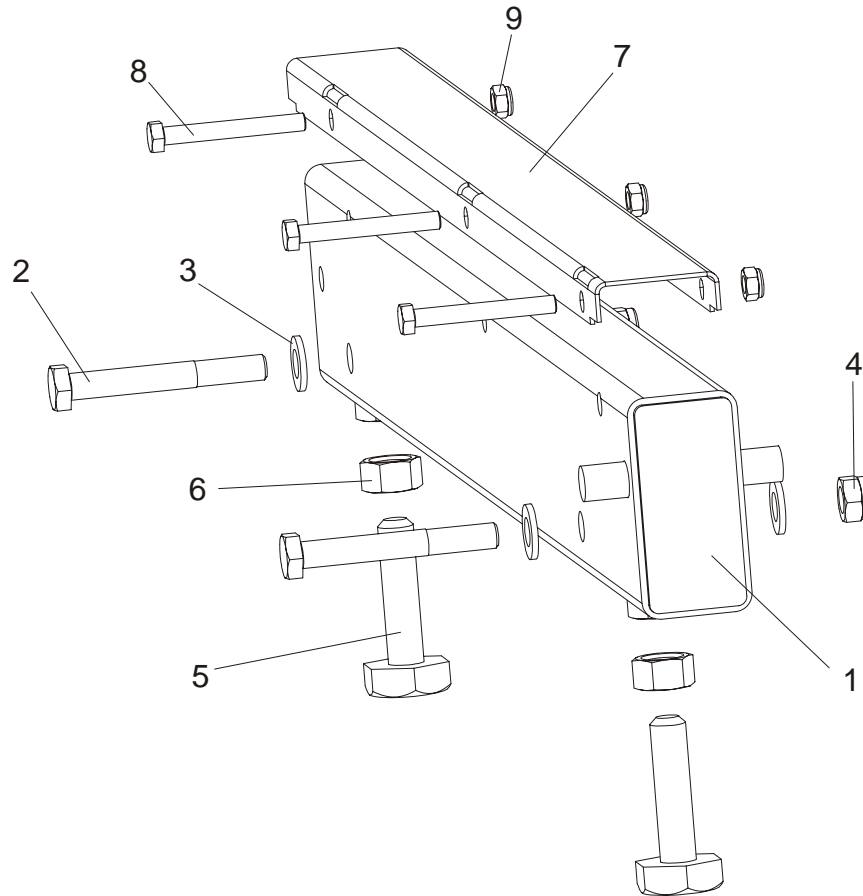
5.3 Bed Rail Assembly, Front Middle (BX12/24 Only) and Rear Middle (BX24 Only)

REF	DESCRIPTION (◆ Indicates Parts Available In Assemblies Only)	PART #	QTY.
1	BED RAIL ASSEMBLY, FRONT MIDDLE	091556	1
2	Bolt, M12 x 90-8.8 Hex Head Zinc	F81004-2	2
3	Washer, 13 Flat Zinc	F81056-1	4
4	Nut, M12-8 Hex Nylon Zinc Lock	F81034-2	2
5	Bolt, M16 Bed Rail Adjustment	505006	2
6	Nut, M16-5-B Hex	F81036-5	2
7	COVER, STAINLESS STEEL BED RAIL	099124	2
8	BOLT, M8X65-5.8 HEX HEAD ZINC	F81002-3	3
9	NUT, M8-8-B HEX NYLON ZINC LOCK	F81032-2	3

5.4 Bed Rail Assembly, Rear Middle (BX12 Only)

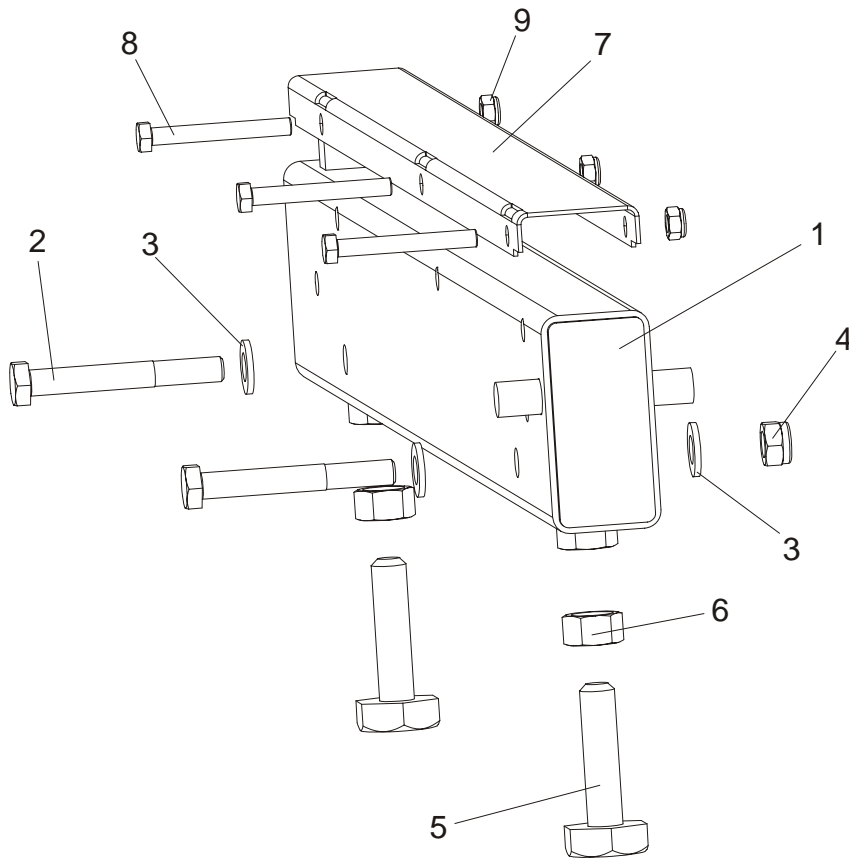

REF	DESCRIPTION (◆ Indicates Parts Available In Assemblies Only)	PART #	QTY.
1	BED RAIL ASSEMBLY, REAR MIDDLE PAINTED	091557	1
2	Bolt, M12 x 90-8.8 Hex Head Zinc	F81004-2	2
3	Washer, 13 Flat Zinc	F81056-1	4
4	Nut, M12-8 Hex Nylon Zinc Lock	F81034-2	2
5	Bolt, M16 Bed Rail Adjustment	505006	2
6	Nut, M16-5-B Hex	F81036-5	2
7	COVER, STAINLESS STEEL BED RAIL	099124	2
8	BOLT, M8X65-5.8 HEX HEAD ZINC	F81002-3	3
9	NUT, M8-8-B HEX NYLON ZINC LOCK	F81032-2	3

5.5 Pivot Bed Rail Assembly (BX24 Only)

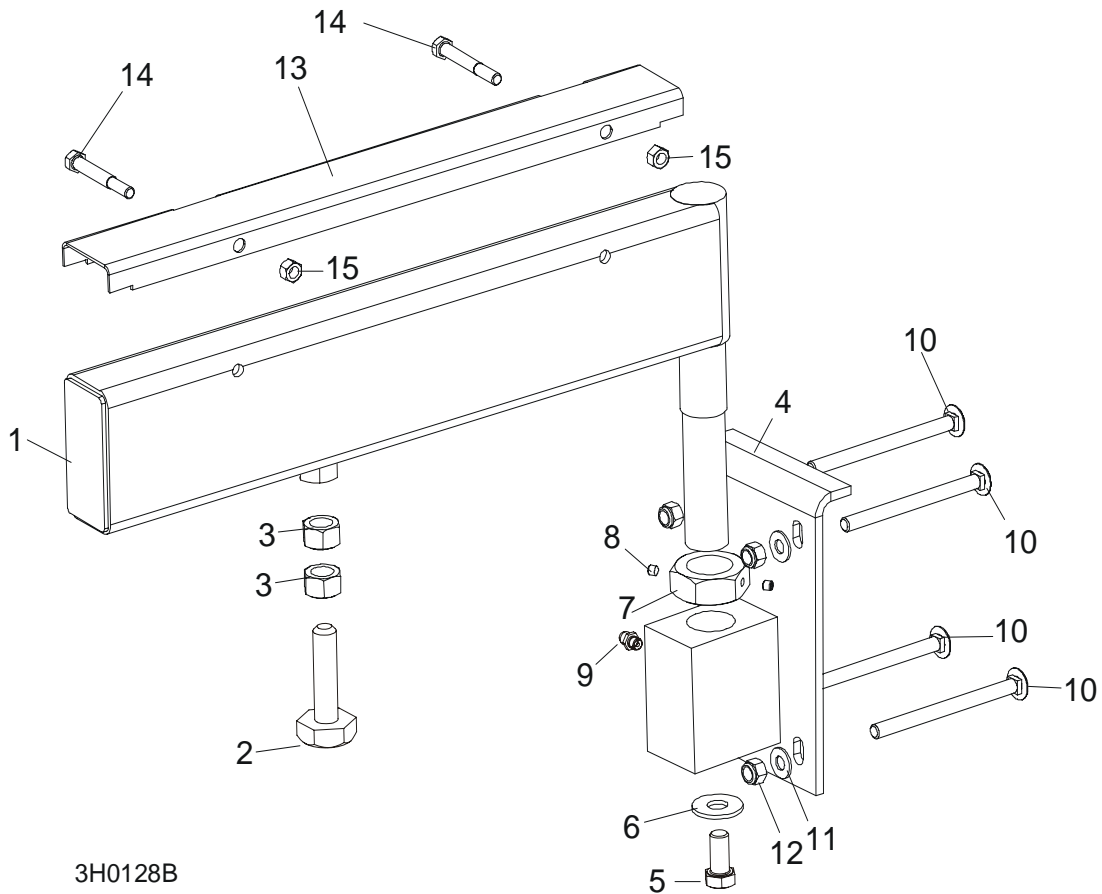

3H0128B

REF	DESCRIPTION (◆ Indicates Parts Available In Assemblies Only)	PART #	QTY.
	PIVOT BED RAIL ASSEMBLY	087855	2
1	Pivot Bed Rail Weldment	087848	1
	Bolt Assembly, Bed Rail Adjustment		1
2	Bolt, M16 Bed Rail Adjustment	505006	1
3	Nut, M16-5.8 Hex Zinc	F81036-1	2
4	Bracket, Pivot Rail Mounting	087841-1	1
5	Bolt, M12x25-8.8 Hex Head Full Thread Zinc	F81004-31	1
6	Washer, 9/16" Flat Zinc	F05011-52	1
7	Nut, Pivot Rail Adjustment	F81039-2	1
8	Screw, 1/4-28 x 1/4" Brass Tip Set	F05005-42	2
9	Fitting, M6 A Type Straight Grease	086280	1
10	BOLT, M10 X 120-8.8 CARRIAGE HEAD ZINC	F81003-33	8
11	WASHER,10.5 FLAT ZINC	F81055-1	8
12	NUT, M16-8 HEX NYLON ZINC LOCK	F81036-2	8
13	Cover, Stainless Steel Pivot Bed Rail (LT40M)	099123	1
14	Bolt, M8x65-5.8 Hex Head Zinc	F81002-3	4
15	Nut, M8-8-B Hex Nylon Zinc Lock	F81032-2	4

5.6 Pivot Bed Rail Assembly (BX12 Only)

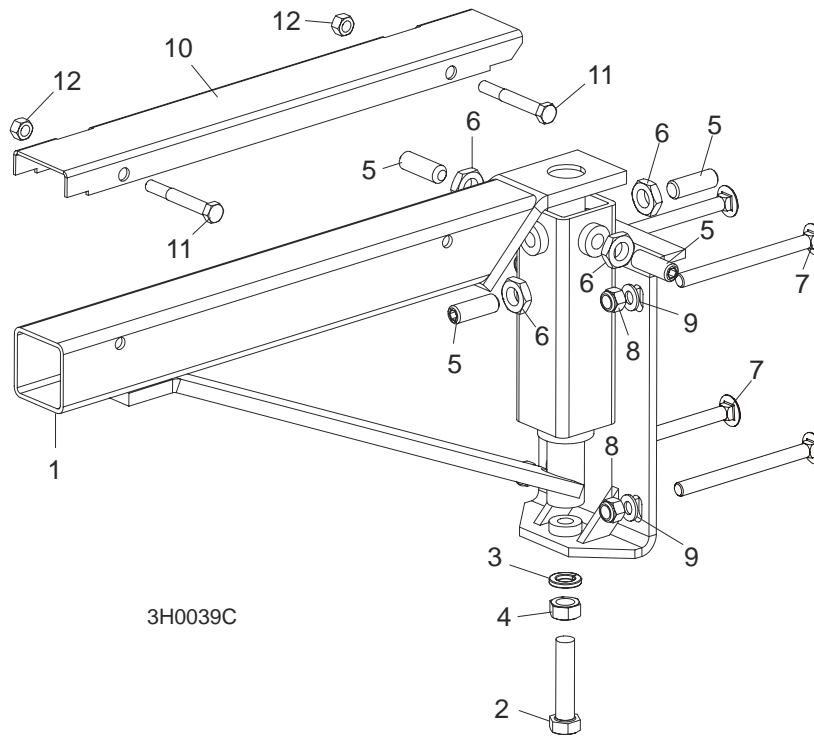

REF	DESCRIPTION (◆ Indicates Parts Available In Assemblies Only)	PART #	QTY.
	PIVOT BED RAIL COMPLETE	093906	1
1	Pivot Bed Rail Weldment	093907-1	1
2	Bolt, M12x1.25x65mm Hex Head Gr. 8.8 Zinc	F81004-40	1
3	Washer, Z12.2 Split Lock	F81056-2	1
4	Nut, M12x1,25-8 Hex Zinc	F81034-8	1
5	Screw, M12x1,25x30 DIN913 Nylon Insert Socket Set	F81016-1	4
6	Nut, M12x1,25 DIN439 Thin	F81034-9	4
7	Bolt, M10 X 120 8.8 Carriage Head Zinc	F81003-33	4
8	Nut, M10-8-B Hex Nylon Zinc Lock	F81033-1	4
9	Washer, 10.5 Flat Zinc	F81055-1	4
10	Cover, Pivot Bed Rail	093962	1
11	Bolt, M8 X 65-5.8 Hex Head Zinc	F81002-3	2
12	Nut, M8-8-B Hex Nylon Zinc Lock	F81032-2	2

5.7 Auxiliary Bed Rail Assembly (BX24 Only)

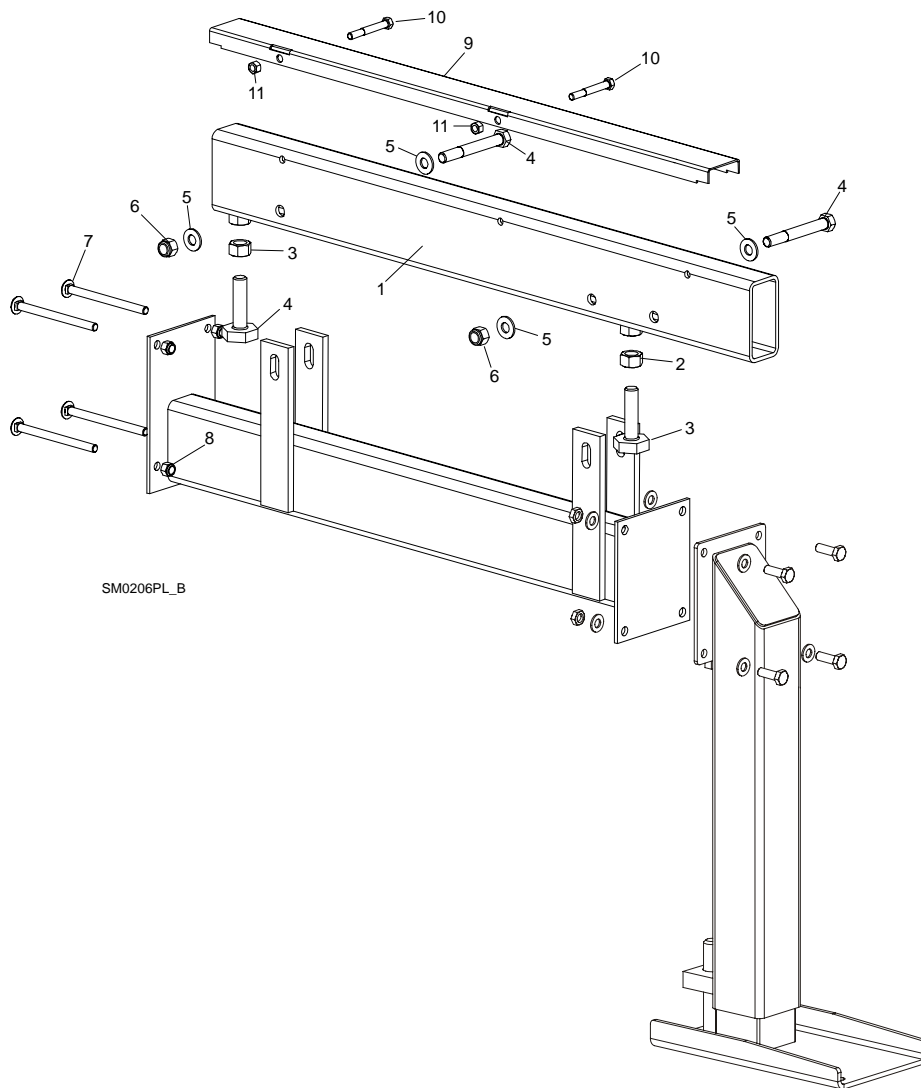

REF	DESCRIPTION (◆ Indicates Parts Available In Assemblies Only)	PART #	QTY.	
	BED RAIL ASSEMBLY, BX24	093175	1	
1	Bed Rail Tube, BX24	093180-1	1	◆
	M16 Bolt & 2 Nuts	093710	2	
2	Nut, M16 Hex	F81036-5	2	
3	Bolt, Bed Rail Adjustment	505006	1	
4	Bolt, M12X 90MM,HH,Grade 5.8,ZINC	F81004-2	2	
5	Washer, M12 , FLAT, ZINC	F81056-1	4	
6	Nut, M12,Hexagon,Nylon, zinc,lock	F81034-2	2	
7	BOLT, M10 X 120 8.8 CARRIAGE HEAD ZINC	F81003-33	4	
8	NUT, M10-8-B HEX NYLON ZINC LOCK	F81033-1	4	
9	COVER, STAINLESS STEEL BED RAIL	085464	1	◆
10	BOLT, M8 X 65-5.8 HEX HEAD ZINC	F81002-3	3	
11	NUT, M6 WING ZINC	F81032-2	3	

5.8 Log Side Support Assembly

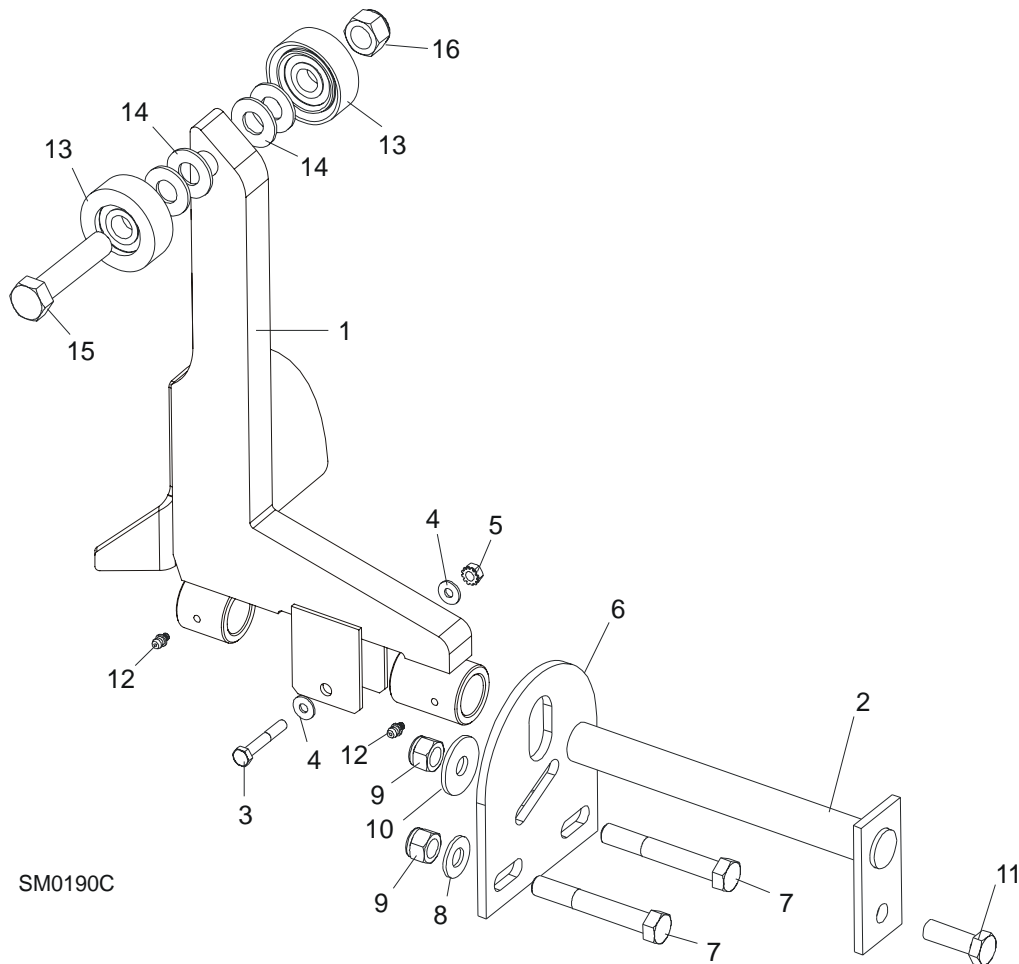

REF	DESCRIPTION (◆ Indicates Parts Available In Assemblies Only)	PART #	QTY.
	LOG SIDE SUPPORT KIT - MANUAL FOR BX6 BED EXTENSIONS	500960	1
1	Support, Log Side w/Guard	099785-1	1
	Mounting Kit, Manual Log Side Support	K09440	1
2	Pin, Log Side Support Zinc-plated	091549-1	1
3	Bolt, M8x45 - 8.8 Hex Head Full Thread Zinc	F81002-14	1
4	Washer, 13 Flat Zinc	F81056-1	2
5	Nut, M8-8-B Hex Nylon Zinc Lock	F81032-2	1
6	Plate, Side Support Mount Painted	091591-1	1
7	Bolt, M12x75-8.8 Hex Head Zinc	F81004-21	2
8	Washer, 13 Flat Zinc	F81056-1	2
9	Nut, M12-8 Hex Nylon Zinc Lock	F81034-2	3
10	Washer, 15 Special Flat Zinc	F81057-3	1
11	Bolt, M12x35-8.8 Hex Head Full Thread Zinc	F81004-24	1
12	Fitting, 3/16" Straight Grease	P04107	2
	ROLLER KIT, SIDE SUPPORT (OPTIONAL)	015109	1
13	Roller Assembly, Side Support	015014	2

5**Bed Extension Parts**
Log Side Support Assembly

14	Washer, 5/8" SAE Flat	F05011-5	4	
15	Bolt, 5/8-11 x 3" Hex Head Grade 5	F05009-37	1	
16	Nut, 5/8-11 Nylon Lock	F05010-34	1	
	Instruction Sheet, Side Support Roller	015109-526	1	

5.9 20 in. M Bed Extension/ Alignment Box/ Feed Chain

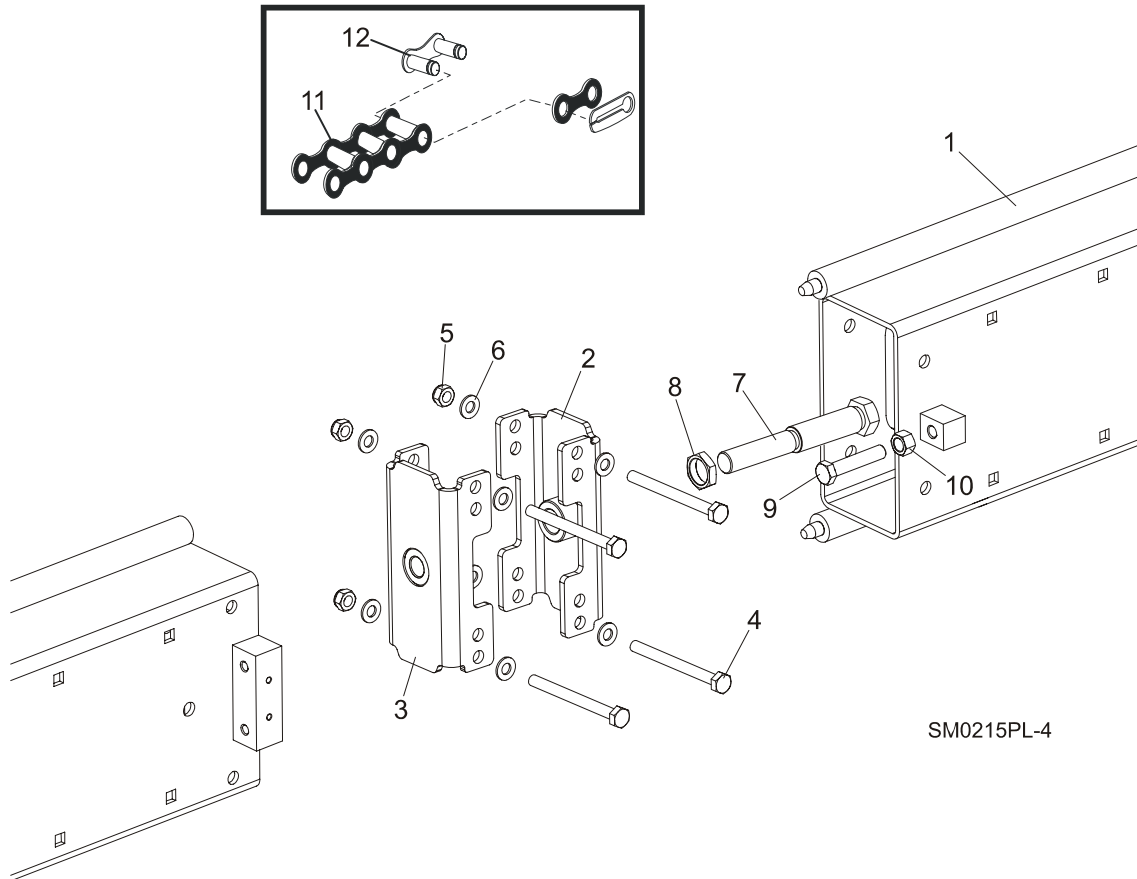

REF	DESCRIPTION (◆ Indicates Parts Available In Assemblies Only)	PART #	QTY.
1	EXTENSION, 20 IN. BED COMPLETE (LT20)	093775	1
	EXTENSION, 20 IN. BED COMPLETE (LT40)	093775-40	1
	EXTENSION, 20 IN. BED COMPLETE (LT70)	093775-70	1
	LINK, BX COMPLETE	501340	1
2	Link, BX (M24)	500989-1	1
3	Link, BX (M20)	501339-1	1
4	Bolt, M10 X 115 8.8 Hex Head	F81003-19	4
5	Nut, M10 - 8 Hex Nylon Lock	F81033-1	4
6	Washer, 10.5, Flat, Zinc	F81055-1	8
7	Bolt, Bed Extension Alignment Hex Head	087188-1	1
8	Nut, Bed Extension Alignment Hex	087626-1	1
9	BOLT, M10 X 35 8.8 HEX HEAD	F81003-11	4
10	WASHER, 10.5 FLAT	F81055-1	4

5

Bed Extension Parts

20 in. M Bed Extension/ Alignment Box/ Feed Chain

11	CHAIN ASSEMBLY, 20 in. BED EXTENSION (LT40)	094263	1	
	Chain, #40 x 20.5" long (41 links)	094261	1	
	CHAIN ASSEMBLY, 20 in. BED EXTENSION (LT70)	094264	1	
	Chain, 10B-1 x 20 5/8" long (33 links)	094262	1	
	CHAIN, #40 X 75 1/2" (BX6)	P11602	1	
	CHAIN, #40 X 143 1/2" (BX12)	P07355	1	
	CHAIN, #40 X 286 1/2" (BX24)	P11909	1	
12	LINK, #40 MASTER	P04200 ¹	1	
	LINK, 10B-1PZ MASTER	088671 ²	1	

¹ Also included in 094263 assembly.

² Included in 094264 assembly.

5.10 Stationary Legs

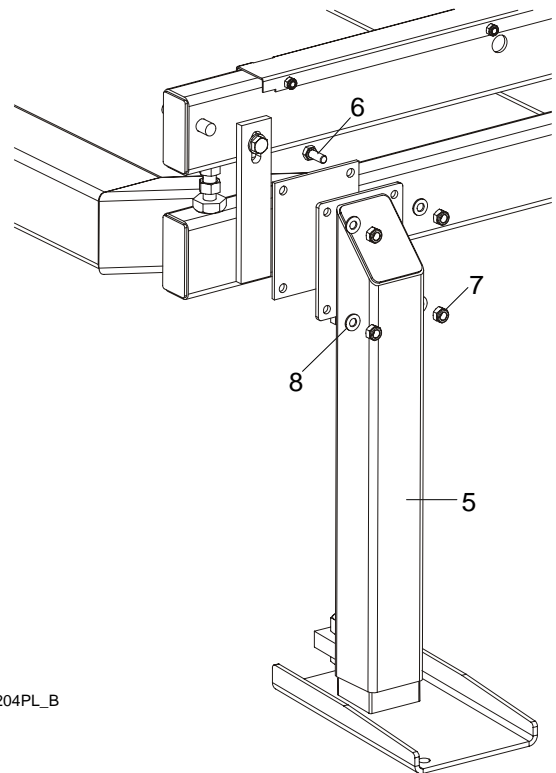
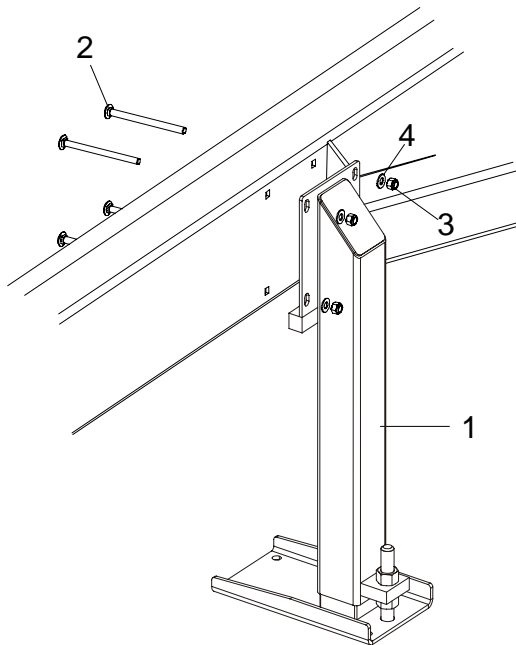

SM0204PL_B

REF	DESCRIPTION (◆ Indicates Parts Available In Assemblies Only)	PART #	QTY.
1	LEG, OUTRIGGER STATIONARY RIGHT (2 REQ'D FOR BX6 & BX12; 4 FOR BX24)	501640	2/4
2	BOLT, M10 X 120 8.8 CARRIAGE HEAD	F81003-33	8/12
3	NUT, M10 HEX NYLON LOCK	F81033-1	8/12
4	WASHER, 10.5 FLAT	F81055-1	8/12
5	LEG, OUTRIGGER STATIONARY LEFT (2 REQ'D FOR BX6 & BX12; 3 FOR BX24)	501639	2/3
6	BOLT, M10 X 25 HEX HEAD	F81003-11	8/12
7	NUT, M10 HEX NYLON LOCK	F81033-1	8/12
8	WASHER, 10.5 FLAT	F81055-1	8/12

5.11 Stationary Legs, Middle Short (BX24 Only)

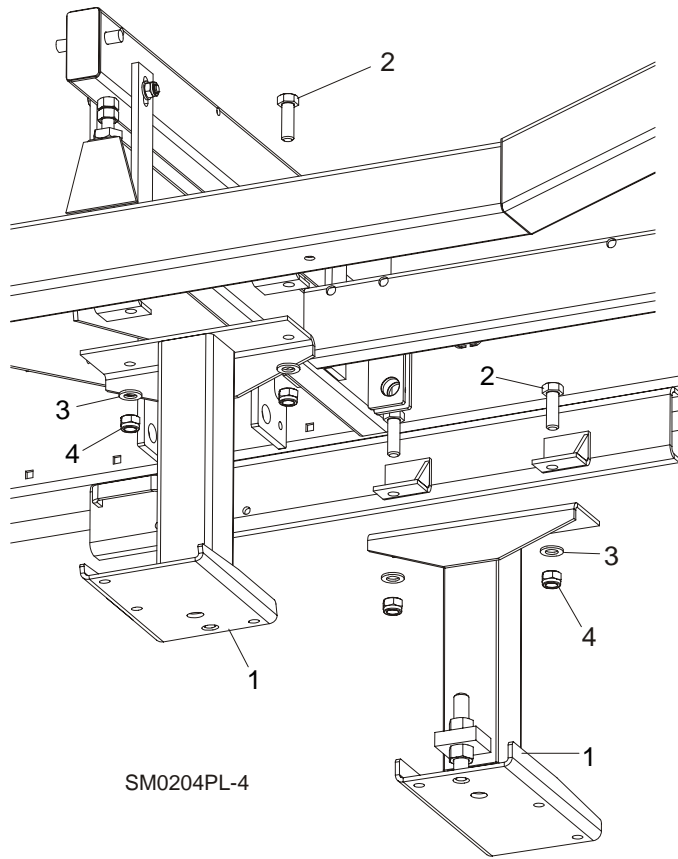

REF	DESCRIPTION (◆ Indicates Parts Available In Assemblies Only)	PART #	QTY.
1	LEG, OUTRIGGER STATIONARY MIDDLE	501637	2
2	BOLT, M12 X 30 8.8 CARRIAGE HEAD	F81004-22	4
3	WASHER, 13 FLAT	F81056-1	4
4	NUT, M12 - 8 HEX NYLON LOCK	F81034-2	4

5.12 Main Bed Tube Outrigger Leg

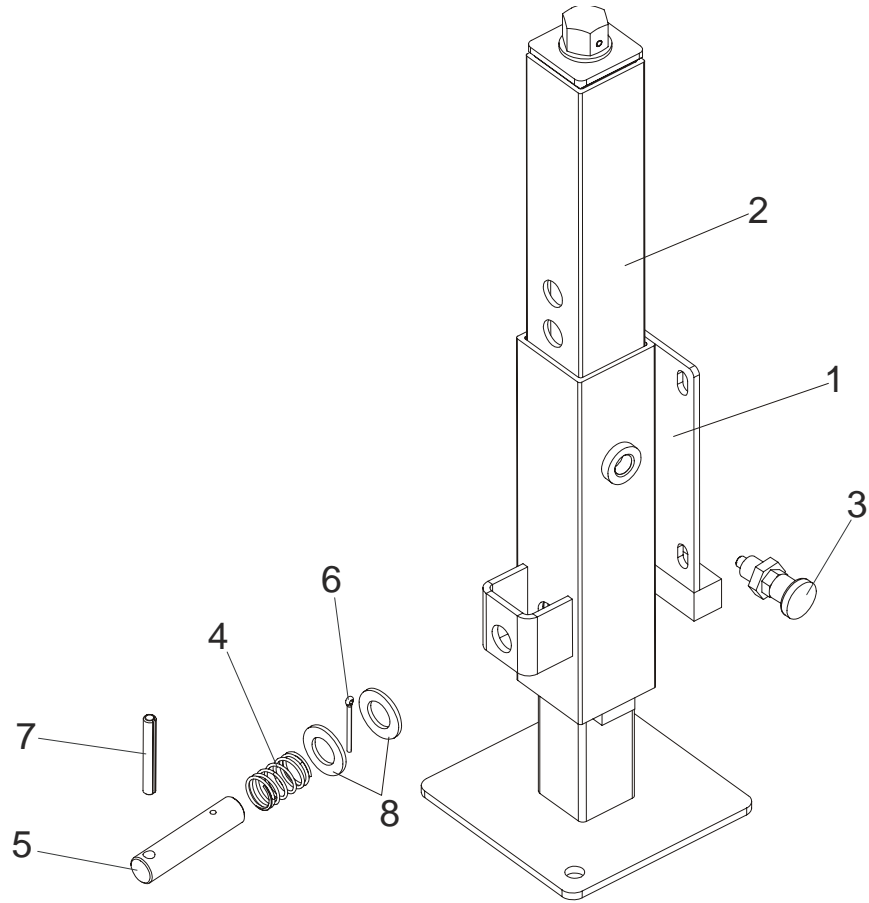

SMTUV22

REF	DESCRIPTION (◆ Indicates Parts Available In Assemblies Only)	PART #	QTY.
	LEG, FINE ADJUST OUTRIGGER COMPLETE (MOUNTED TO MAIN BED TUBE)	094584	1
1	Guide, Fine Adjust Outrigger Leg	094418-1	1
2	Leg , Fine Adjust Outrigger	093589	1
3	Detent Pin	090197	1
4	Spring, 21 Dia. x 38 x 2 Zinc-plated	087040	1
5	Pin, Outrigger Leg Locking Zinc-plated	087012-1	1
6	Pin, S-Zn 4x25 Cotter	F81043-2	1
7	Pin, 8x65 Roll Zinc	F81046-1	1
8	Washer, 21 Flat Zinc	F81059-2	2

5.13 Side FAO Leg

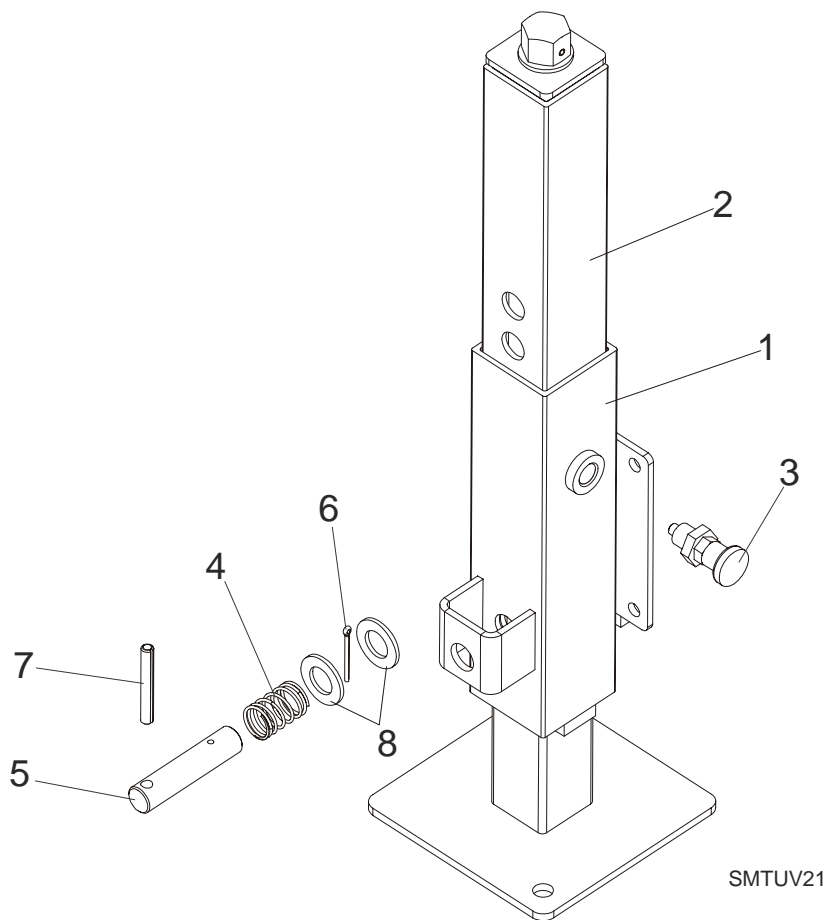

REF	DESCRIPTION (◆ Indicates Parts Available In Assemblies Only)	PART #	QTY.
	LEG, FINE ADJUST SIDE OUTRIGGER - COMPLETE	094583	1
1	Guide, Side FAO Leg	094417-1	1
2	Leg , Fine Adjust Outrigger	093589	1
3	Detent Pin	090197	1
4	Spring, 21 Dia. x 38 x 2 Zinc-plated	087040	1
5	Pin, Outrigger Leg Locking Zinc-plated	087012-1	1
6	Pin, S-Zn 4x25 Cotter	F81043-2	1
7	Pin, 8x65 Roll Zinc	F81046-1	1
8	Washer, 21 Flat Zinc	F81059-2	2

5.14 Log Clamp/Winch Cable Pulley

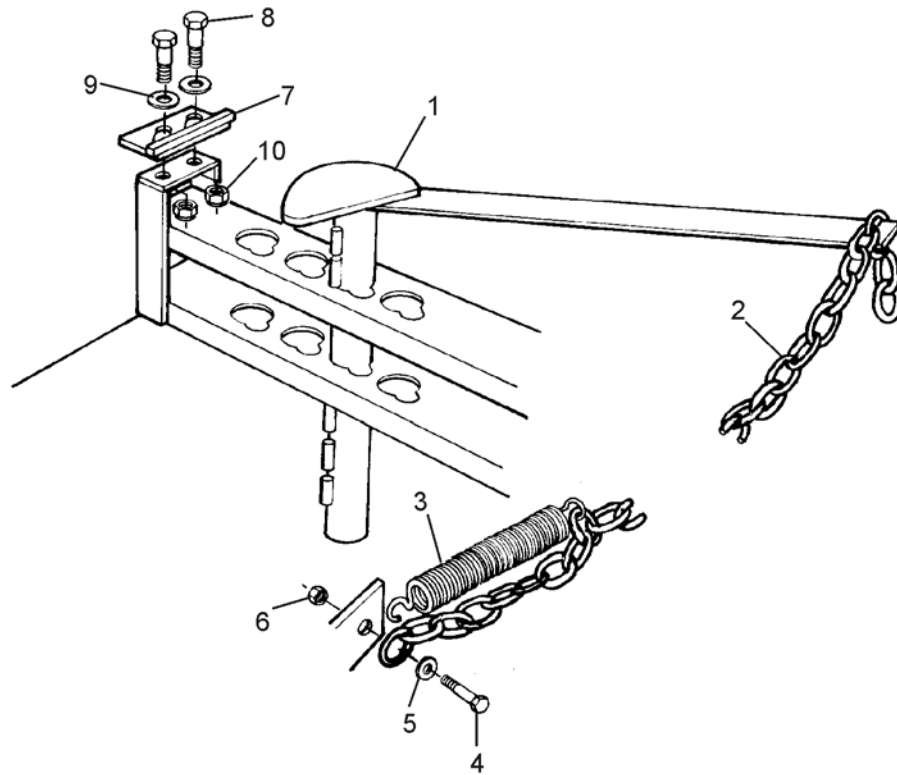

SM0205h

REF	DESCRIPTION (◆ Indicates Parts Available In Assemblies Only)	PART #	QTY.
1	CLAMP, LOG MANUAL MIDDLE	092683	1
2	CHAIN, CLAMPING DOG	M04311	1
3	SPRING, FI 2.8 X FI 22.2 X 183	091864	1
4	BOLT, M10x25-8.8 HEX HEAD FULL THREAD ZINC	F81003-11	1
5	WASHER, 10.5 FLAT ZINC	F81055-1	1
6	NUT, M10-8-B HEX NYLON ZINC LOCK	F81033-1	1
7	PLATE WELDMENT, LOG CLAMP STOP PAINTED	086980-1	1
8	BOLT, M12 X 40-8.8 HEX HEAD FULL THREAD ZINC	F81004-4	2
9	WASHER, 13 FLAT ZINC	F81056-1	2
10	NUT, M12-8 HEX NYLON ZINC LOCK	F81034-2	2

5.15 Brace Kit, SBX6

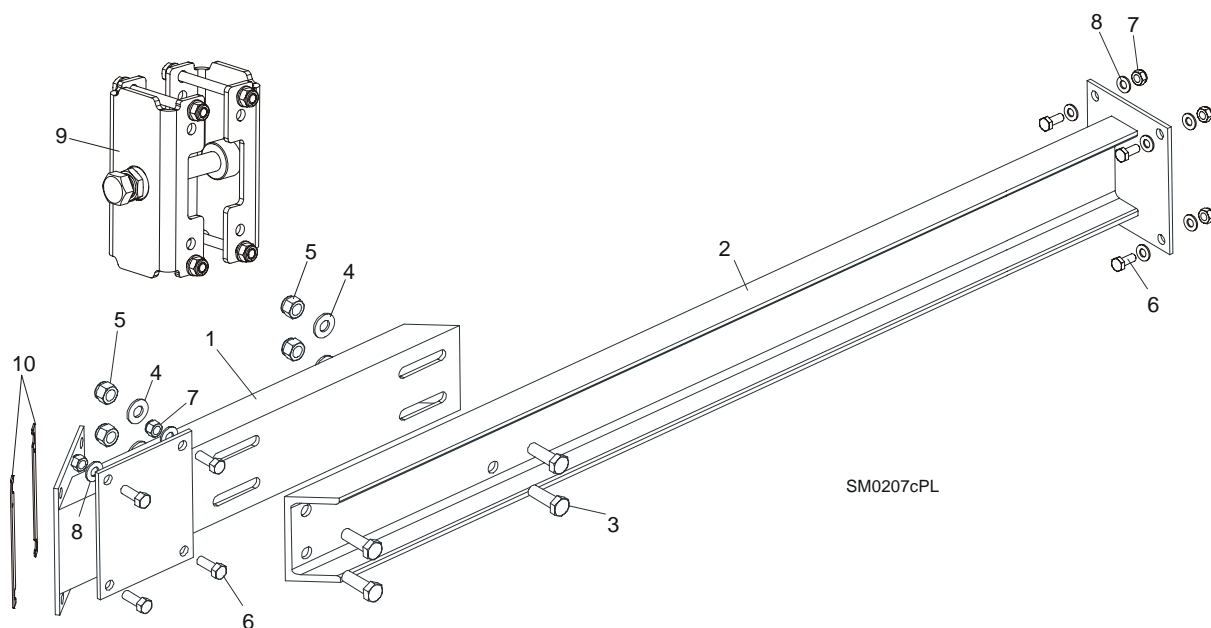

REF	DESCRIPTION (◆ Indicates Parts Available In Assemblies Only)	PART #	QTY.
	BRACE KIT, SBX6	092987	1
1	Brace Weldment, LT30 Bed Extension	085653-1	1
2	Brace Weldment, BX6	092986-1	1
3	Bolt, M12x35-8.8 Hex Head Full Thread Zinc	F81004-24	4
4	Washer, 13 Flat Zinc	F81056-1	4
5	Nut, M12-8 Hex Nylon Zinc Lock	F81034-2	4
6	Bolt, M10 X 25 8.8 Hex Head Full Thread Zinc	F81003-11	4
7	Nut, M10-8-B Hex Nylon Zinc Lock	F81033-1	4
8	Washer, 10.5 Flat Zinc	F81055-1	4
9	Link, BX Complete	501340	1
10	WASHER, SPECIAL PAINTED	086649-1	2

5.16 Brace Kit, MBX6

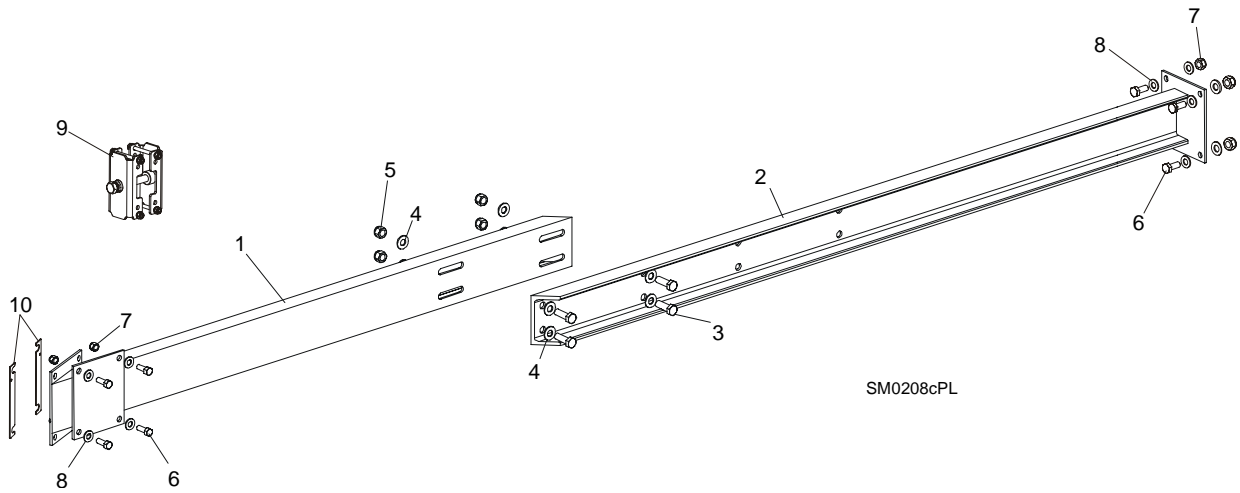

REF	DESCRIPTION (◆ Indicates Parts Available In Assemblies Only)	PART #	QTY.
	BRACE KIT, MBX6	092988	1
1	Brace Weldment, LT40 Bed Extension	092824-1	1
2	Brace Weldment, BX6/BX12	085651-1	1
3	Bolt, M12 X 40-8.8 Hex Head Full Thread Zinc	F81004-4	4
4	Washer, 13 Flat Zinc	F81056-1	8
5	Nut, M12-8 Hex Nylon Zinc Lock	F81034-2	4
6	Bolt, M10 x 25 8.8 Hex Head Full Thread Zinc	F81003-11	4
7	Nut, M10-8-B Hex Nylon Zinc Lock	F81033-1	4
8	Washer, 10.5 Flat Zinc	F81055-1	4
9	Link, BX Complete	501340	1
10	WASHER, SPECIAL PAINTED	086649-1	2

5.17 Brace Kit, LBX6

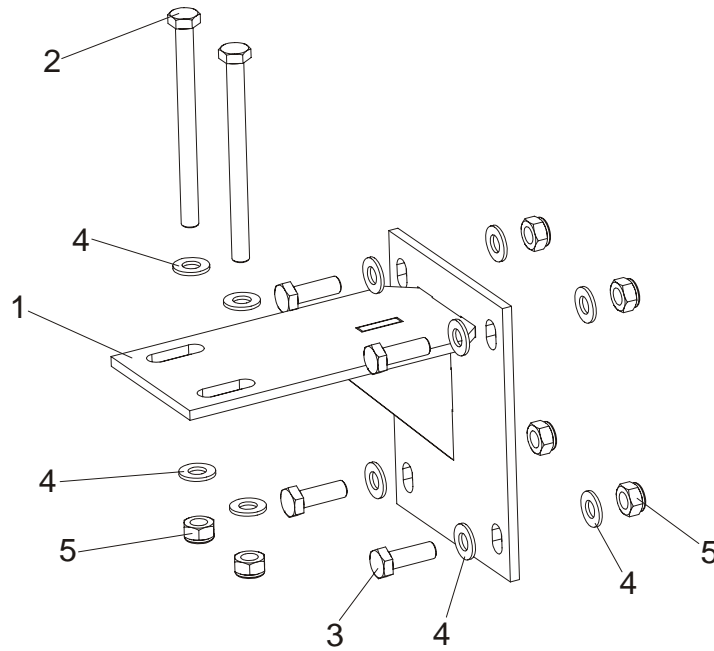

REF	DESCRIPTION (◆ Indicates Parts Available In Assemblies Only)	PART #	QTY.
1	Brace Weldment, LBX6 Bed Extension	090034-1	1
2	Bolt, M10x125-8.8 Fe/Zn5 PN-M/82101	F81003-18	2
3	Bolt, M10x30-5.8-Fe/Zn5 PN-M/82105	F81003-2	4
4	Washer, 10.5 Flat Zinc	F81055-1	12
5	Nut, M10-8-B Hex Nylon Zinc Lock	F81033-1	6

5.18 Brace Kit, SBX12

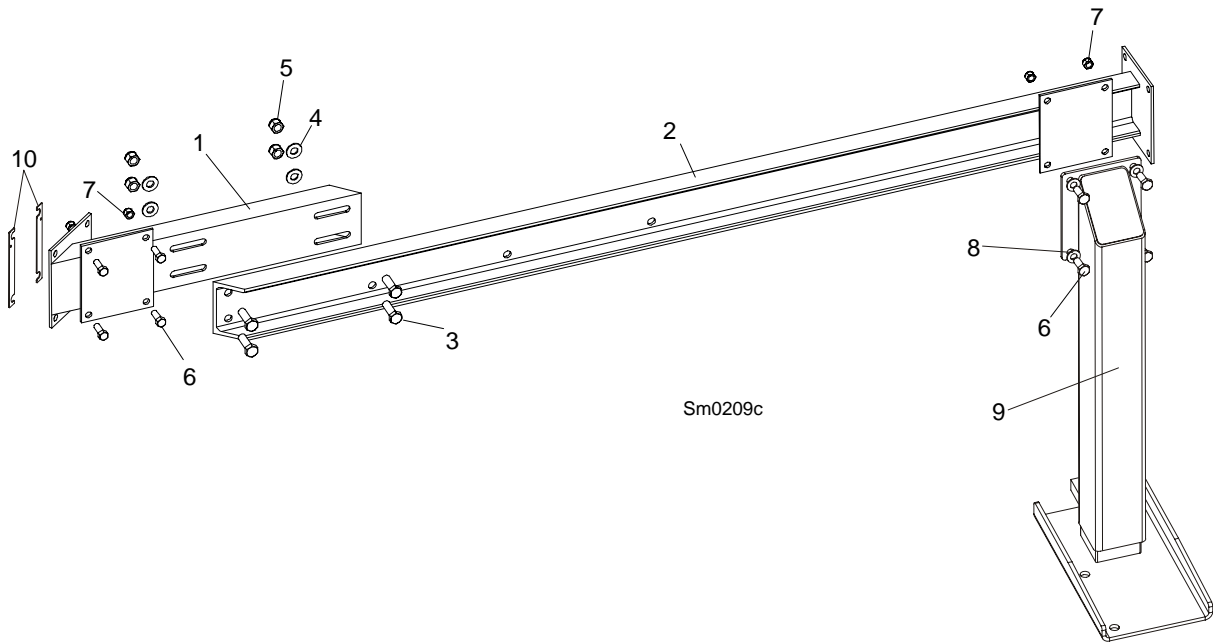

REF	DESCRIPTION (◆ Indicates Parts Available In Assemblies Only)	PART #	QTY.
	BRACE KIT, SBX12	092888	1
1	Brace Weldment, SBX12 Bed Extension	085653-1	1
2	Brace Weldment, BX12	092825-1	1
3	Bolt, M12 x 35-8.8 Hex Head Full Thread Zinc	F81004-24	4
4	Washer, 13 Flat Zinc	F81056-1	8
5	Nut, M12-8 Hex Nylon Zinc Lock	F81034-2	4
6	Bolt, M10x25-8.8 Hex Head Full Thread Zinc	F81003-11	12
7	Nut, M10-8-B Hex Nylon Zinc Lock	F81033-1	12
8	Washer, 10.5 Flat Zinc	F81055-1	24
9	Leg, Outrigger Stationary Left	501639	1
10	WASHER, SPECIAL PAINTED	086649-1	2

5.19 Brace Kit, MBX12

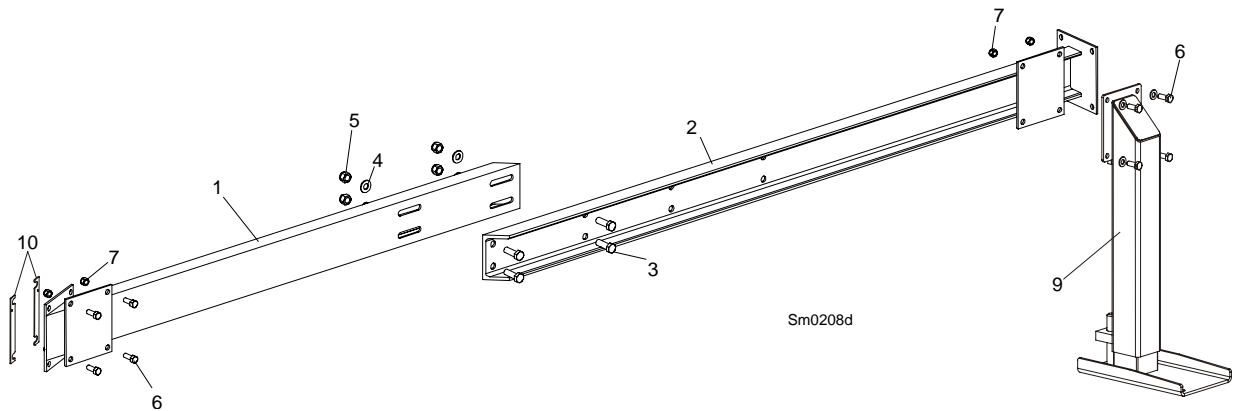

REF	DESCRIPTION (◆ Indicates Parts Available In Assemblies Only)	PART #	QTY.
	BRACE KIT, MBX6/BX12	092887	1
1	Brace Weldment, LT40 Bed Extension	092824-1	1
2	Brace Weldment, BX6/BX12	092823-1	1
3	Bolt, M12 x 35-8.8 Hex Head Full Thread Zinc	F81004-24	4
4	Washer, 13 Flat Zinc	F81056-1	8
5	Nut, M12-8 Hex Nylon Zinc Lock	F81034-2	4
6	Bolt, M10x25-8.8 Hex Head Full Thread Zinc	F81003-11	12
7	Nut, M10-8-B Hex Nylon Zinc Lock	F81033-1	12
8	Washer, 10.5 Flat Zinc	F81055-1	24
9	Leg, Outrigger Stationary Left	501639	1
10	WASHER, SPECIAL PAINTED	086649-1	2

5.20 Brace Kit, LBX12

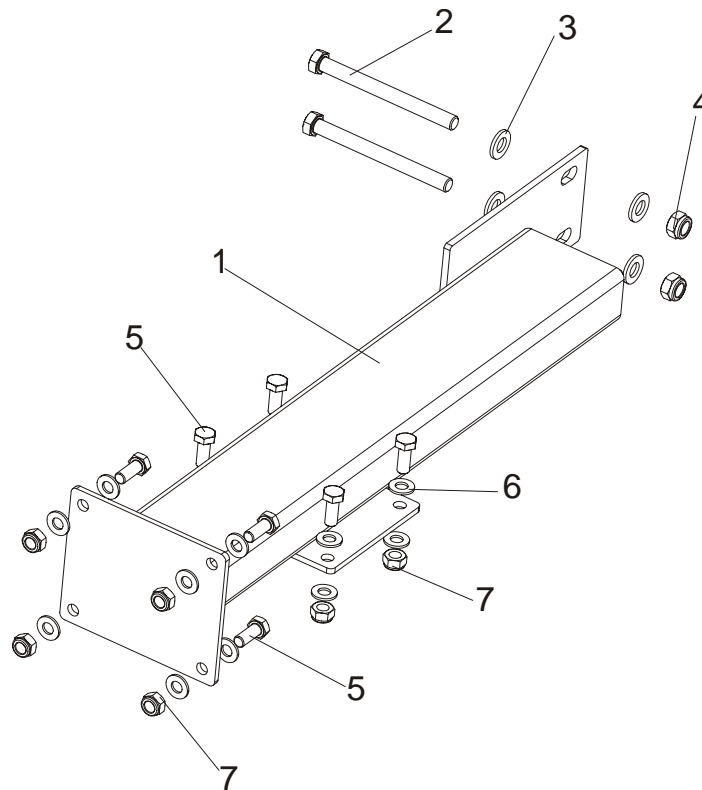

REF	DESCRIPTION (◆ Indicates Parts Available In Assemblies Only)	PART #	QTY.
	BRACE KIT, 40LBX12	094834	1
1	Brace Weldment, 40LBX12 Painted	091177-1	1
2	Bolt, M12x130-8.8 Hex Head Zinc	F81004-36	2
3	Washer, 13 Flat Zinc	F81056-1	4
4	Nut, M12-8 Hex Nylon Zinc Lock	F81034-2	2
5	Bolt, M10x25-8.8 Hex Head Full Thread Zinc	F81003-11	8
6	Washer, 10.5 Flat Zinc	F81055-1	16
7	Nut, M10-8-B Nylon Hex Zinc Lock	F81033-1	8

5.21 Brace Kit, SBX24

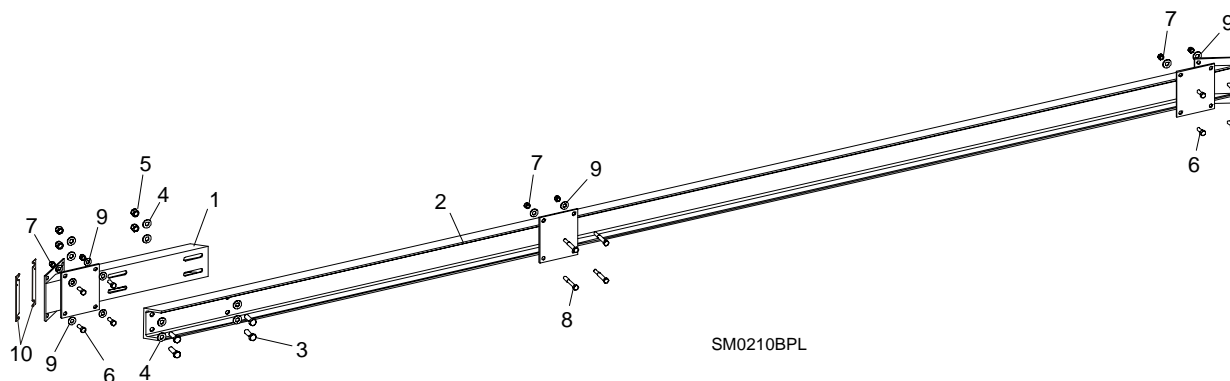

REF	DESCRIPTION (◆ Indicates Parts Available In Assemblies Only)	PART #	QTY.
BRACE KIT,SBX24			
1	Brace Weldment, LT30 Bed Extension	085653-1	1
2	Brace Weldment, BX24	093143-1	1
3	Bolt, M12 x 40-8.8 Hex Head Full Thread Zinc	F81004-4	4
4	Washer, 13 Flat Zinc	F81056-1	8
5	Nut, M12-8-B Hex Zinc	F81034-1	4
6	Bolt, M10x25-8.8 Hex Head Full Thread Zinc	F81003-11	8
7	Nut, M10-8-B Nylon Hex Zinc Lock	F81033-1	12
8	Bolt, M10 x 80-8.8 Hex Head Zinc	F81003-51	4
9	Washer, 10.5 Flat Zinc	F81055-1	16
10	WASHER, SPECIAL PAINTED	086649-1	4

5.22 Brace Kit, MBX24

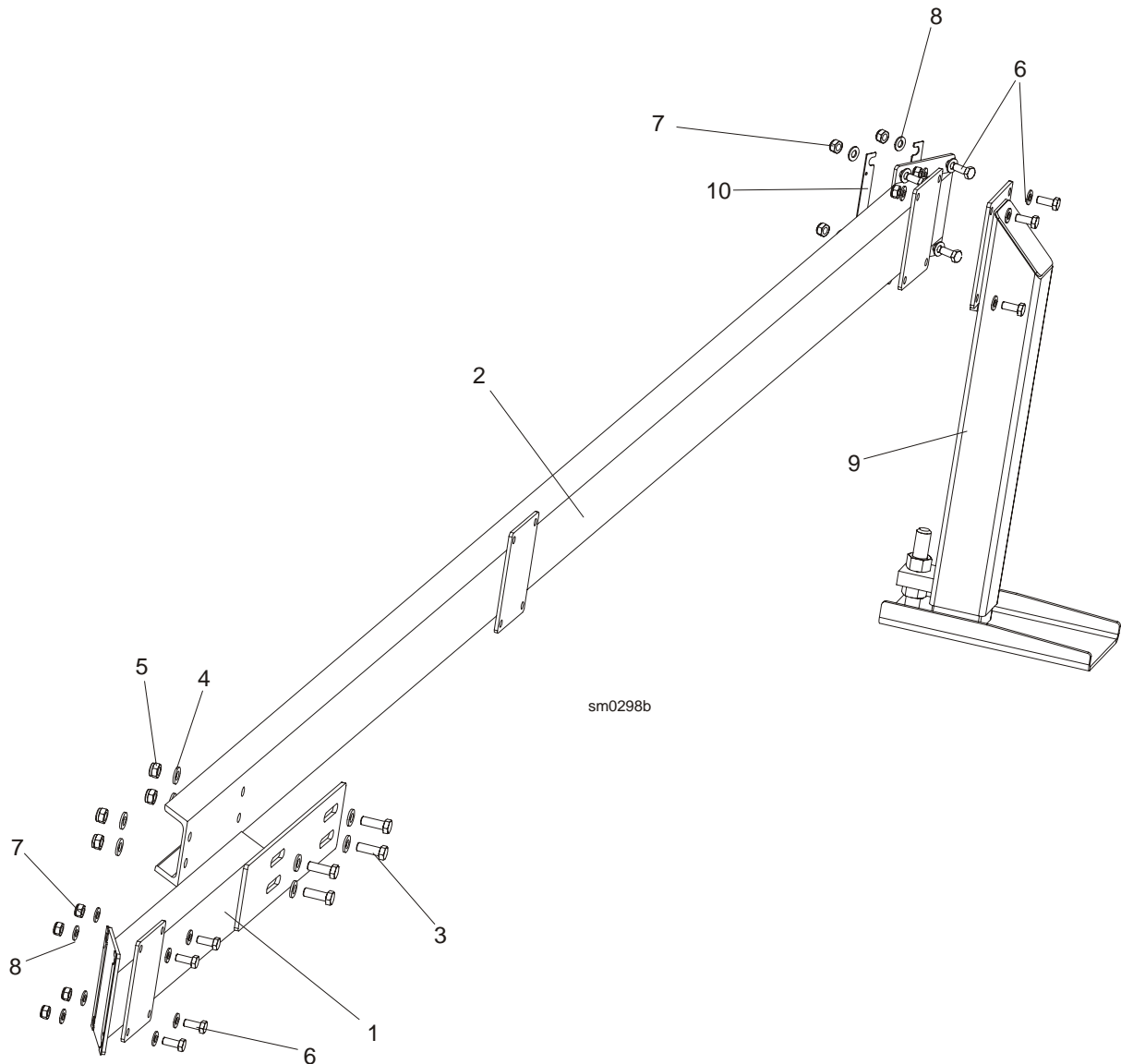

REF	DESCRIPTION (◆ Indicates Parts Available In Assemblies Only)	PART #	QTY.
BRACE KIT, LT40/LT40HD BX24			
1	Brace Weldment, LT40 Bed Extension	093205-1	1
2	Brace Weldment, BX24	093145-1	1
3	Bolt, M12 x 35-8.8 Hex Head Full Thread Zinc	F81004-24	4
4	Washer, 13 Flat Zinc	F81056-1	8
5	Nut, M12-8-B Hex Zinc	F81034-1	4
6	Bolt, M10x25-8.8 Hex Head Full Thread Zinc	F81003-11	16
7	Nut, M10-8-B Nylon Hex Zinc Lock	F81033-1	16
8	Washer, 10.5 Flat Zinc	F81055-1	32
9	Leg, Outrigger Stationary Left	501639	3
10	WASHER, SPECIAL PAINTED	086649-1	4

5.23 Bed Extension, MBX6 Super

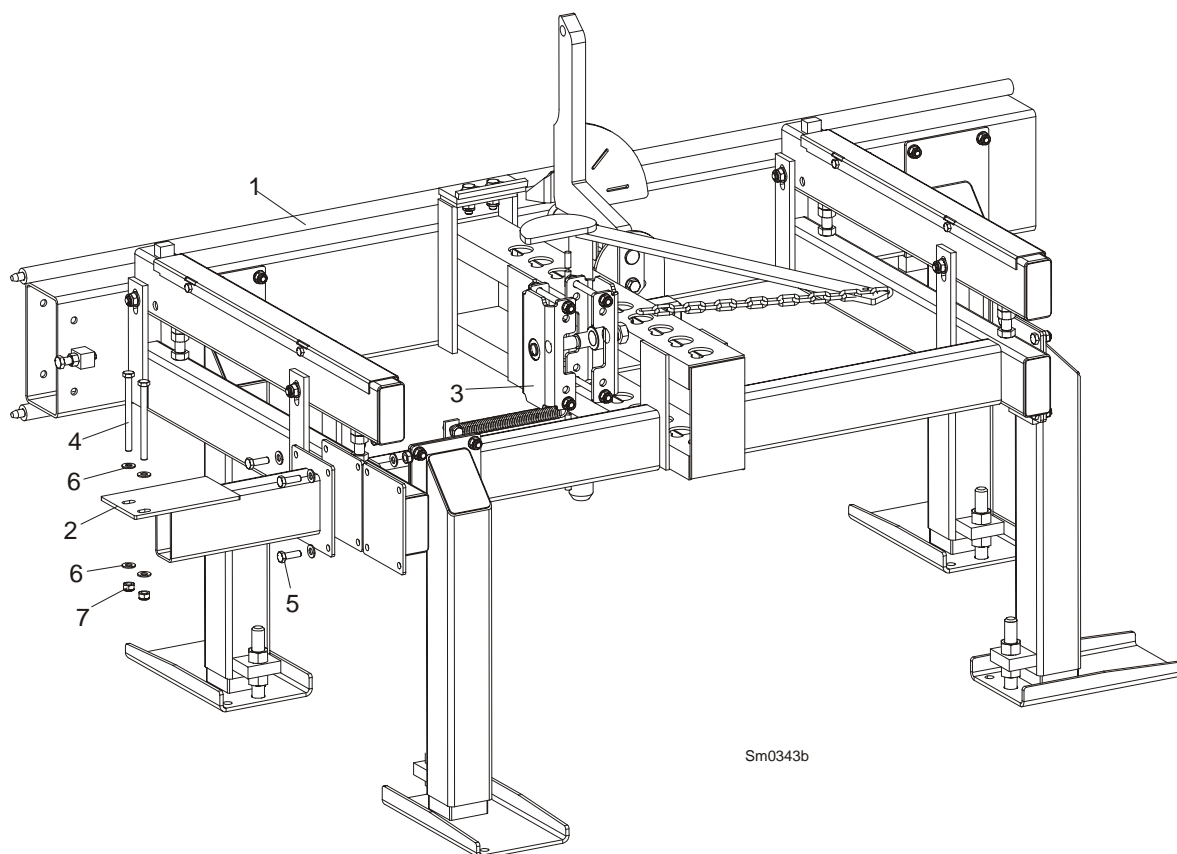

REF	DESCRIPTION (◆ Indicates Parts Available In Assemblies Only)	PART #	QTY.
	BED EXTENSION, MBX6 SUPER	40MBX6S	1
	BED EXTENSION, MBX6 SUPER	70MBX6S	1
1	BED EXTENSION 6FT	BX6	1
	BRACE KIT, MBX6 SUPER COMPLETE	099198	1
2	BRACE KIT, MBX6 SUPER	099199-1	1
3	LINK, BX COMPLETE	501340	1
4	BOLT, M10x125-8.8 HEX HEAD ZINC	F81003-18	2
5	BOLT, M10x30-5.8 HEX HEAD FULL THREAD ZINC	F81003-2	4
6	WASHER, 10.5 FLAT ZINC	F81055-1	12
7	NUT, M10-8-B HEX NYLON ZINC LOCK	F81033-1	6

5.24 Bed Extension, MBX12 Super

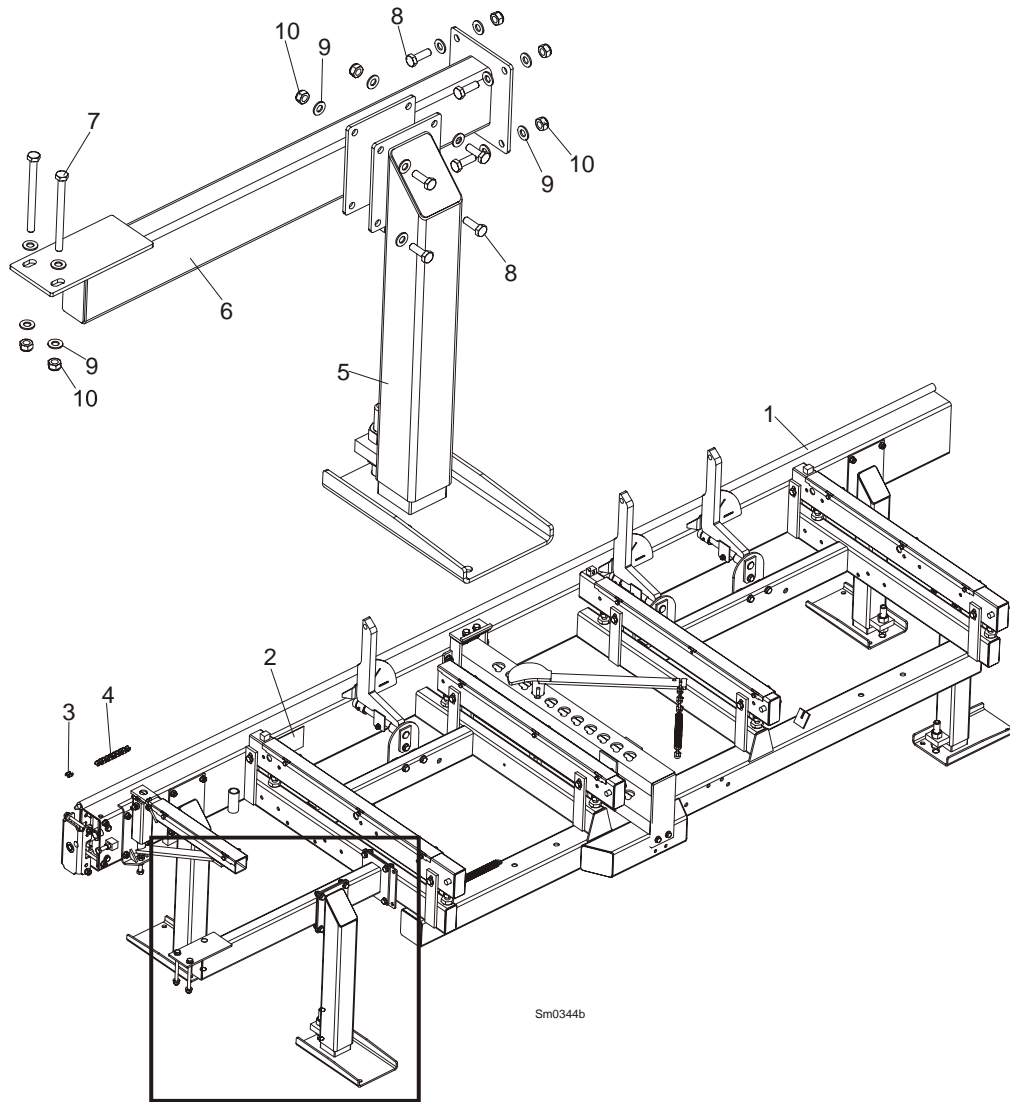

REF	DESCRIPTION (◆ Indicates Parts Available In Assemblies Only)	PART #	QTY.
	BED EXTENSION, MBX12 SUPER	40MBX12S	1
	BED EXTENSION, MBX12 SUPER	70MBX12S	1
1	BED EXTENSION 12FT	092744	1
2	DECAL, 40MBX12 BED EXTENSION	093945	1
3	LINK, #40 MASTER	P04200	1
4	CHAIN, 3.6M BED EXTENSION	P07355	1
	BRACE KIT, MBX12 SUPER COMPLETE	099630	1
5	LEG, OUTRIGGER STATIONARY LEFT	501639	1
6	BRACE KIT, MBX12 SUPER	098733-1	1
7	BOLT, M10x125-8.8 HEX HEAD ZINC	F81003-18	2
8	BOLT, M10x30-5.8 HEX HEAD FULL THREAD ZINC	F81003-2	8
9	WASHER, 10.5 FLAT ZINC	F81055-1	20
10	NUT, M10-8-B HEX NYLON ZINC LOCK	F81033-1	10

5.25 Bed Extension, MBX24 Super

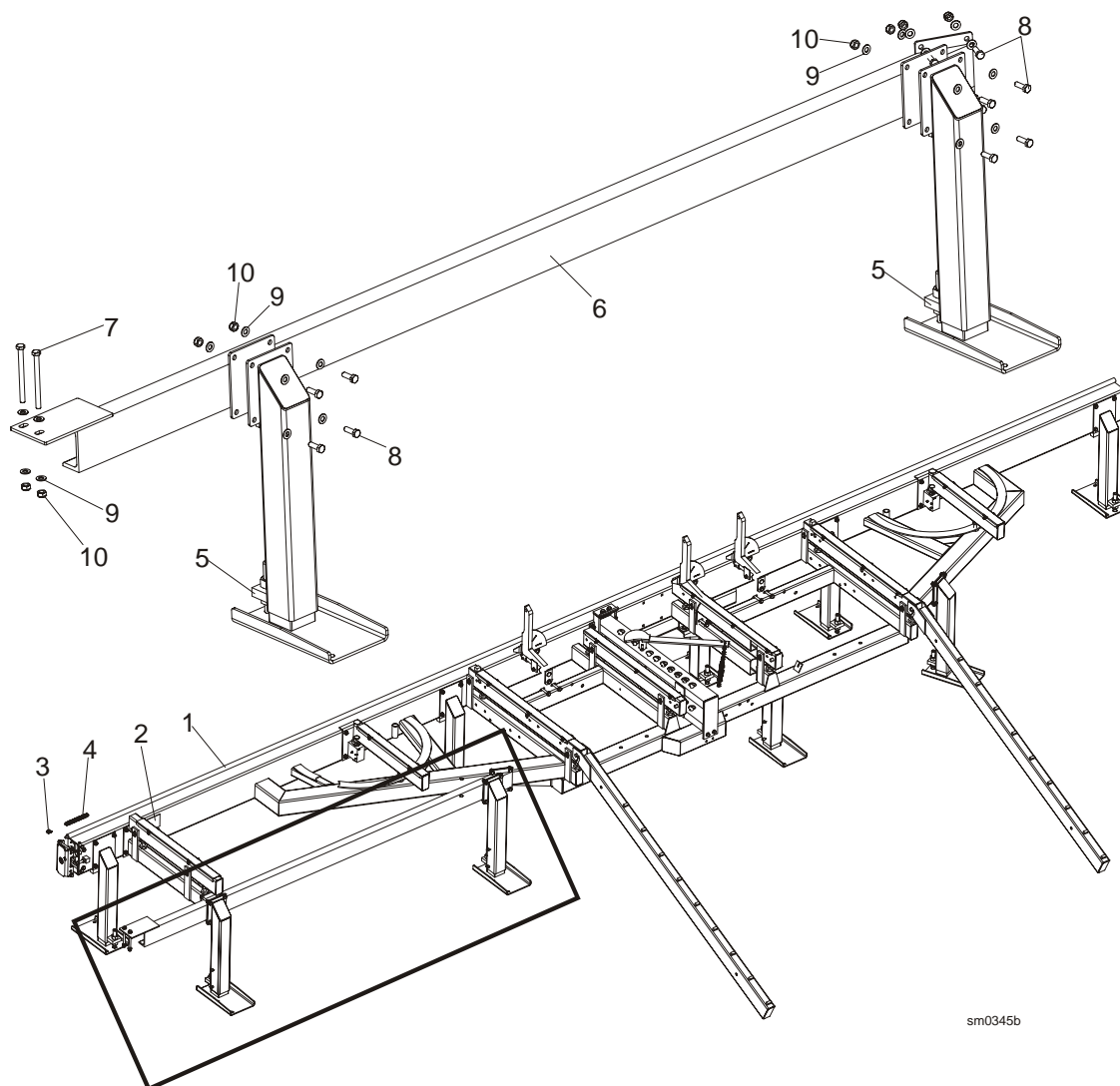

sm0345b

REF	DESCRIPTION (◆ Indicates Parts Available In Assemblies Only)	PART #	QTY.
	BED EXTENSION, MBX24 SUPER	40MBX24S	1
	BED EXTENSION, MBX24 SUPER	70MBX24S	1
1	BED EXTENSION 24FT	093149	1
2	DECAL, 40MBX24 BED EXTENSION	093948	1
3	LINK, #40 MASTER	P04200	1
4	CHAIN, #40 286 1/2	P11909	1
	BRACE KIT, MBX24 SUPER COMPLETE	099197	1
5	LEG, OUTRIGGER STATIONARY LEFT	501639	1
6	BRACE KIT, MBX24 SUPER	099201-1	1
7	BOLT, M10x125-8.8 HEX HEAD ZINC	F81003-18	2
8	BOLT, M10x30-5.8 HEX HEAD FULL THREAD ZINC	F81003-2	8
9	WASHER, 10.5 FLAT ZINC	F81055-1	20
10	NUT, M10-8-B HEX NYLON ZINC LOCK	F81033-1	10