

LX25, LX50, LX55 Trailer

Parts Manual

LX25, LX50, LX55 TRAILER rev.A1.00

**(LX25 and LX55 sawmills are available
for the US market only)**

Safety is our #1 concern!

Form #2613

Off-Road use only!



**Scan QR code to watch the assembly video
for LX50 Start and LX50 Super.**

California
Proposition 65 Warning



WARNING: Breathing gas/diesel engine exhaust exposes you to chemicals known to the State of California to cause cancer and birth defects or other reproductive harm.

Always start and operate the engine in a well-ventilated area.
If in an enclosed area, vent the exhaust to the outside.
Do not modify or tamper with the exhaust system.
Do not idle the engine except as necessary.

For more information go to **www.P65warnings.ca.gov**.



WARNING: Drilling, sawing, sanding or machining wood products can expose you to wood dust, a substance known to the State of California to cause cancer. Avoid inhaling wood dust or use a dust mask or other safeguards for personal protection.

For more information go to **www.P65Warnings.ca.gov/wood**.

Active Patents assigned to Wood-Mizer, LLC

Wood-Mizer, LLC has received patents that protect our inventions which are a result of a dedication to research, innovation, development, and design. Learn more at: woodmizer.com/patents

©2024 Wood-Mizer LLC

Printed in the United States of America, all rights reserved. No part of this manual may be reproduced in any form by any photographic, electronic, mechanical or other means or used in any information storage and retrieval system without written permission from

Wood-Mizer, LLC
8180 West 10th Street
Indianapolis, Indiana 46214

Table of Contents

Section-Page

SECTION 1	PARTS LIST	1-1
1.1	How to Use the Parts List.....	1-1
1.2	Sample Assembly	1-1
1.3	Axle - LX50 Trailer (605773)	1-2
1.4	Frame - LX50 Trailer	1-3
1.5	Drawbar - LX50 Trailer	1-5
1.6	Drawbar - LX50 Trailer (EU market only)	1-6
1.7	Accessories - LX50 Trailer	1-7
1.8	Accessories - LX50 Trailer - USA (140321)	1-8
1.9	Trailer Improvement Kit - LX50 Trailer	1-10
1.10	Decals - LX50 Trailer	1-11

SECTION 1 PARTS LIST

1.1 How to Use the Parts List

- Use the index above to locate the assembly that contains the part you need.
- Go to the appropriate section and locate the part in the illustration.
- Use the number pointing to the part to locate the correct part number and description in the table.
- Parts shown indented under another part are included with that part.
- Parts marked with a diamond (◆) are only available in the assembly listed above the part.

See the sample table below. Sample Part #A01111 includes part F02222-2 and subassembly A03333. Subassembly A03333 includes part S04444-4 and subassembly K05555. The diamond (◆) indicates that S04444-4 is not available except in subassembly A03333. Subassembly K05555 includes parts M06666 and F07777-77. The diamond (◆) indicates M06666 is not available except in subassembly K05555.

1.2 Sample Assembly				
REF.	DESCRIPTION (◆ Indicates Parts Available In Assemblies Only)	PART #	QTY	
	Sample Assembly, Complete (Includes All Indented Parts Below)	A01111	1	
1	Sample Part	F02222-22	1	
	Sample Subassembly (Includes All Indented Parts Below)	A03333	1	
2	Sample Part (◆ Indicates Part Is Only Available With A03333)	S04444-4	1	◆
	Sample Subassembly (Includes All Indented Parts Below)	K05555	1	
3	Sample Part (◆ Indicates Part Is Only Available With K05555)	M06666	2	◆

To Order Parts:

- From Europe call our European Headquarters and Manufacturing Facility in Kolo, Poland at **+48-63-2626000**. From the continental U.S., call our toll-free Parts hotline at **1-800-525-8100**. Have your customer number, vehicle identification number, and part numbers ready when you call. From other international locations, contact the Wood-Mizer distributor in your area for parts.

Office Hours:

Country	Monday - Friday	Saturday	Sunday
Poland	7-15	Closed	Closed
US	8 a.m.- 5 p.m.	8 a.m.- 12 p.m.	Closed



CAUTION! It is strongly recommended that only original spare parts be used.

1.3 Axle - LX50 Trailer (605773)

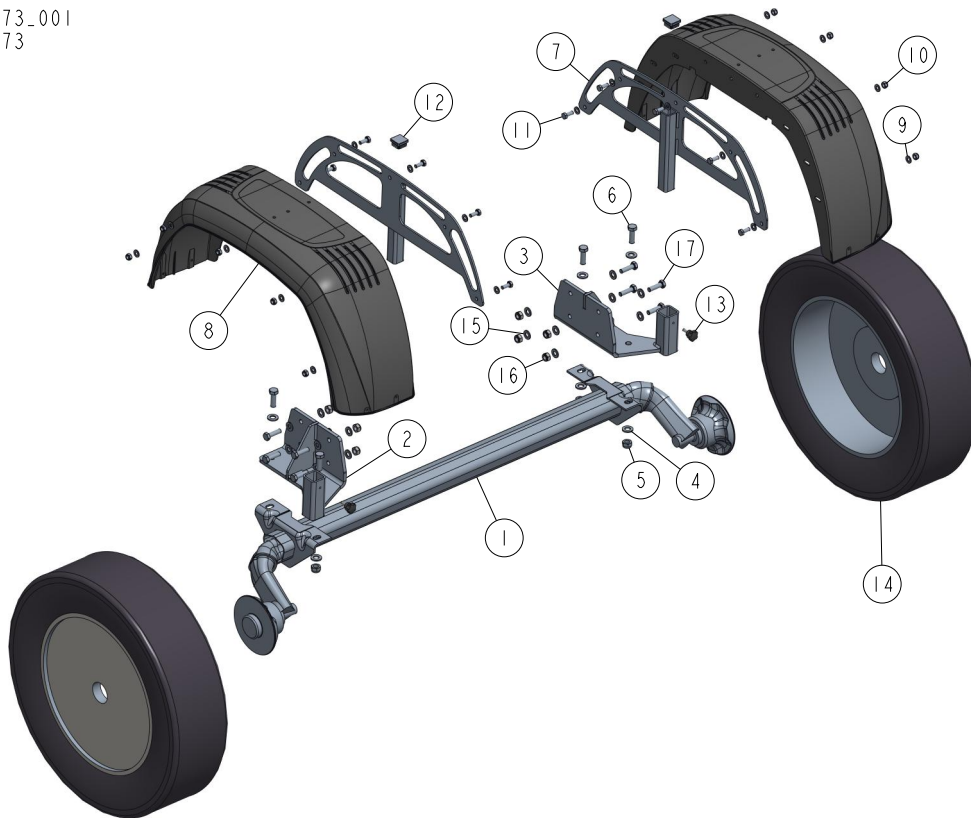
605773-001
605773

REF	DESCRIPTION (◆ indicates parts available in assemblies only)	PART #	QTY
-	AXLE, LX50 TRAILER COMPLETE	605773	1
1	AXLE, AL-KO 750KG	605772	1
2	MOUNT ASSEMBLY, AXLE	605774-1	1
3	MOUNT ASSEMBLY, AXLE	605778-1	1
4	WASHER, 13 FLAT ZINC, WASHER, M12 , FLAT	F81056-1	8
5	NUT, M12-8, HEX, NYLON, ZINC, LOCK	F81034-2	4
6	BOLT M12X35 HH ZC FT 8.8 DIN 933	F81004-24	4
-	BRACKET, FENDER COMPLETE	607317	2
7	BRACKET, FENDER	600076-1	1
8	FENDER, AL-KO EA200 (1 259 576)	538909	1
9	WASHER, 8.4 FLAT ZINC	F81054-1	10
10	NUT, M8-8-B HEX NYLON ZINC LOCK	F81032-2	5
11	BOLT, M8X20-8.8 HEX HEAD FULL THREAD ZIN	F81002-4	5
12	CAP, 30X30X3 1540 DIA.	099463	1
13	KNOB, STAR DIA25/M6X16	541412	2
14	WHEEL, 155/80 R13 79T; 4JX13H2 ET 30 COM	501134	2
15	WASHER, 10.5 FLAT ZINC	F81055-1	16
16	NUT, M10-8-B HEX NYLON ZINC LOCK	F81033-1	8
17	BOLT,M10X35-8.8 HEX HEAD FULL THREAD ZIN	F81003-17	8

1.4 Frame - LX50 Trailer

600080_017
600080_MANUAL

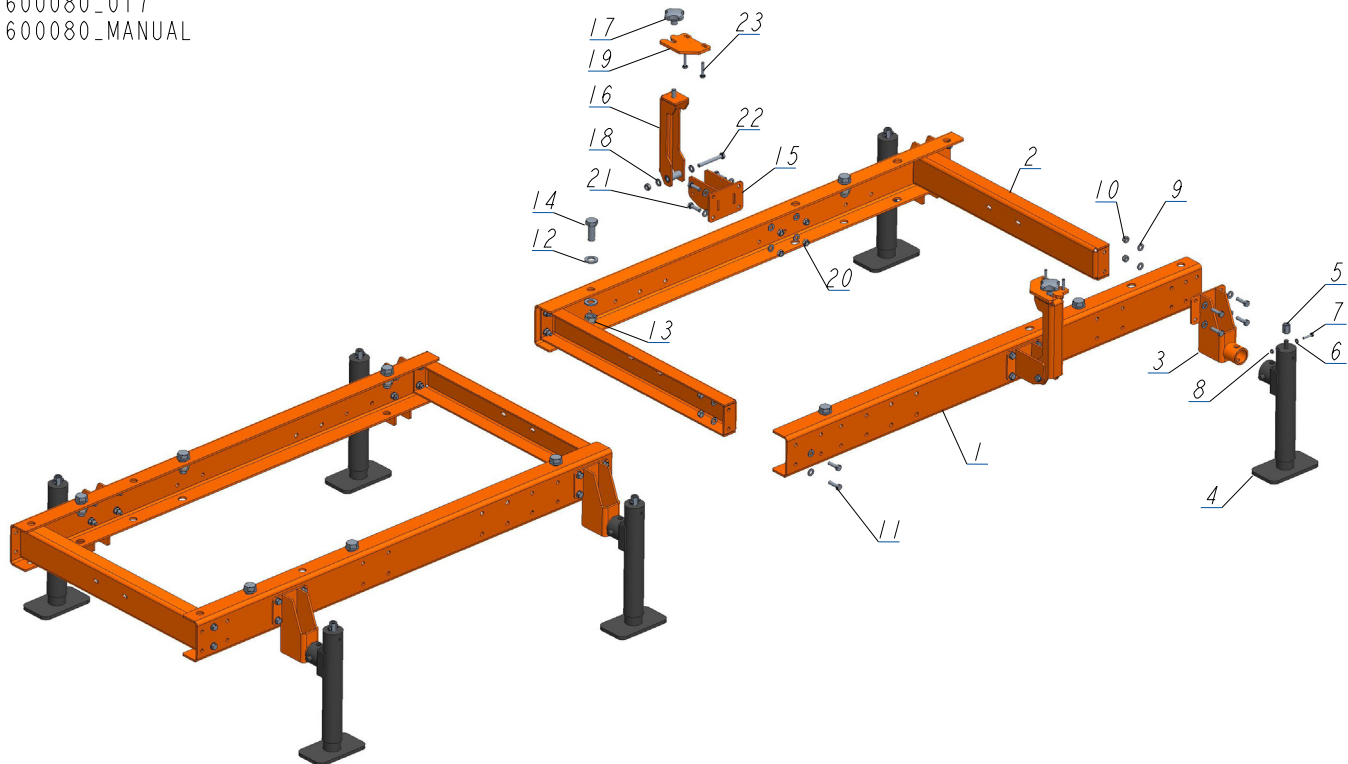

REF	DESCRIPTION (◆ indicates parts available in assemblies only)	PART #	QTY
-	TRAILER, LX50	600080	1
1	BEAM, LX50 TRAILER	597862-1	4
2	CROSSBEAM, TRAILER	600061-1	4
3	BASE, LEG	597878-1	6
4	LEG, SUPPORT - MOBILE SAWMILLS	110403	6
5	NUT, LEG ADJUSTMENT	550467-1	6
6	WASHER, 6.4 FLAT ZINC, WASHER, M6, FLAT,	F81053-1	12
7	BOLT, M6X30-8.8 HEX HEAD FULL THREAD ZIN	F81001-8	6
8	NUT, M6-8-B HEX NYLON ZINC LOCK	F81031-2	6
9	WASHER, 10.5 FLAT ZINC	F81055-1	66
10	NUT, M10-8-B HEX NYLON ZINC LOCK	F81033-1	32
11	BOLT, M10X35-8.8 HEX HEAD FULL THREAD ZIN	F81003-17	32
12	WASHER, 21 FLAT ZINC	F81059-2	20
13	NUT, M20-8 DIN985 HEX NYLON ZINC LOCK	F81037-2	10
14	BOLT, M20X50-8.8-B HEX HEAD FULL THREAD	F81007-17	10
-	BRACKET, SAWHEAD LOCK COMPLETE	605820	2
15	BRACKET, SAWHEAD LOCK	605819-1	1
16	SUPPORT, LX50 SAWHEAD	605818-1	1
17	KNOB, KIPP K1794.631290	605814	1
18	WASHER, 10.5 FLAT ZINC	F81055-1	10
19	MOUNT, SAWHEAD	605812-1	1
20	NUT, M10-8-B HEX NYLON ZINC LOCK	F81033-1	5
21	BOLT, M10X35-8.8 HEX HEAD FULL THREAD ZIN	F81003-17	4
22	BOLT, M10X85-8.8 HEX HEAD ZINC	F81003-125	1

REF	DESCRIPTION (◆ indicates parts available in assemblies only)	PART #	QTY	
23	BOLT, M8X40-8.8 HEX HEAD FULL THREAD ZIN	F81002-15	4	

1.5 Drawbar - LX50 Trailer

600080_018
600080_MANUAL

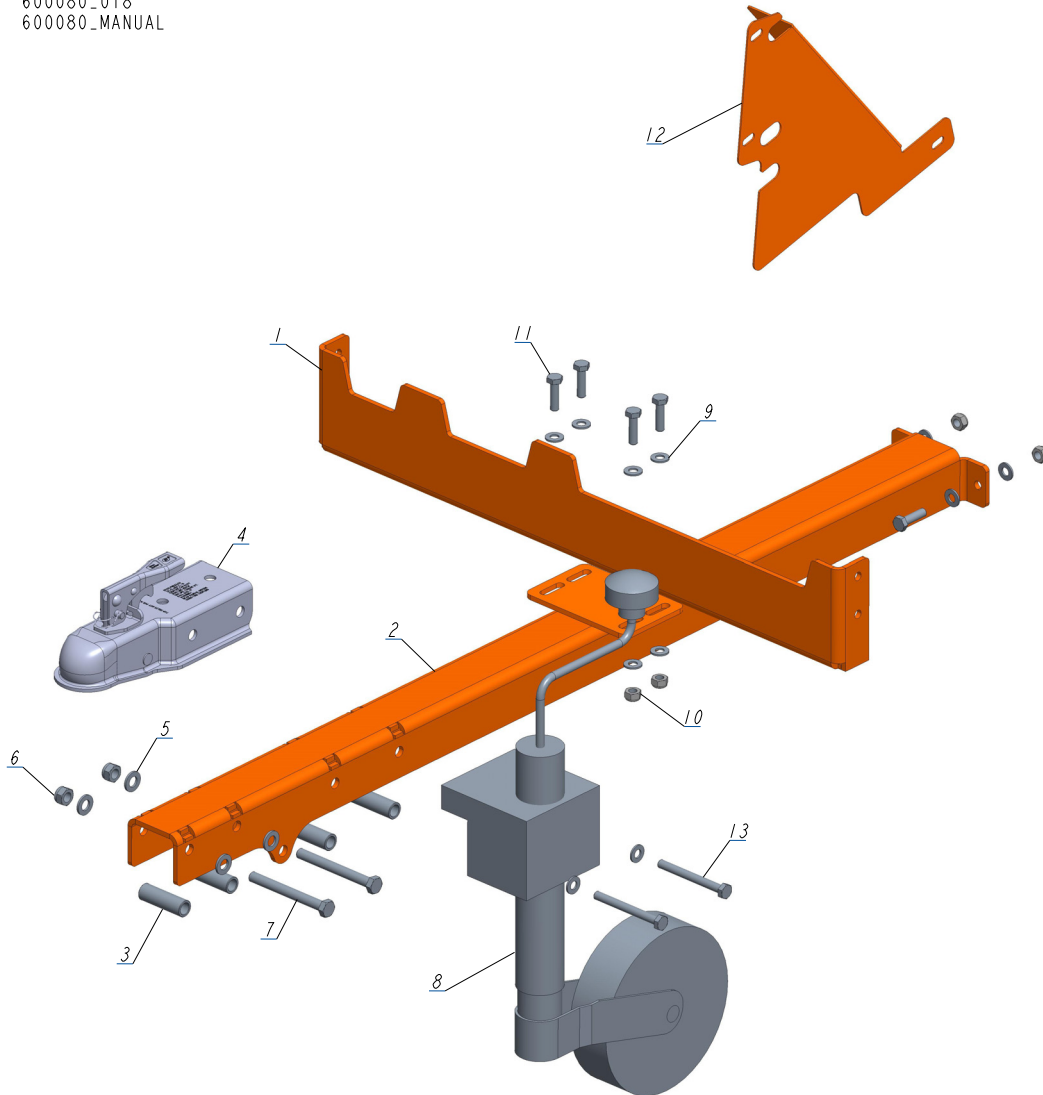

REF	DESCRIPTION (◆ indicates parts available in assemblies only)	PART #	QTY
-	TRAILER, LX50	600080	1
1	PLATE, HITCH CROSS	600007-1	1
-	HITCH, LX50	600083	1
2	DRAWBAR, LX50	600070-1	1
3	BUSHING, 14/20-62	600068-1	4
4	HITCH, 2" ZK-CL2-M-00 BALL	600028	1
5	WASHER, 13 FLAT ZINC, WASHER, M12 , FLAT	F81056-1	4
6	NUT, M12-8 , HEX, NYLON, ZINC, LOCK	F81034-2	2
7	BOLT, M12X110-8.8-B HEX HEAD ZINC	F81004-47	2
8	WHEEL, N48 JOCKEY W/CLAMP (1 222 434+205	538523	1
9	WASHER, 10.5 FLAT ZINC	F81055-1	16
10	NUT, M10-8-B HEX NYLON ZINC LOCK	F81033-1	8
11	BOLT,M10X35-8.8 HEX HEAD FULL THREAD ZIN	F81003-17	6
12	COVER	587136-1	1
13	BOLT, M10X95-8.8-B HEX HEAD ZINC	F81003-71	2

1.6 Drawbar - LX50 Trailer (EU market only)

607400_001
607400

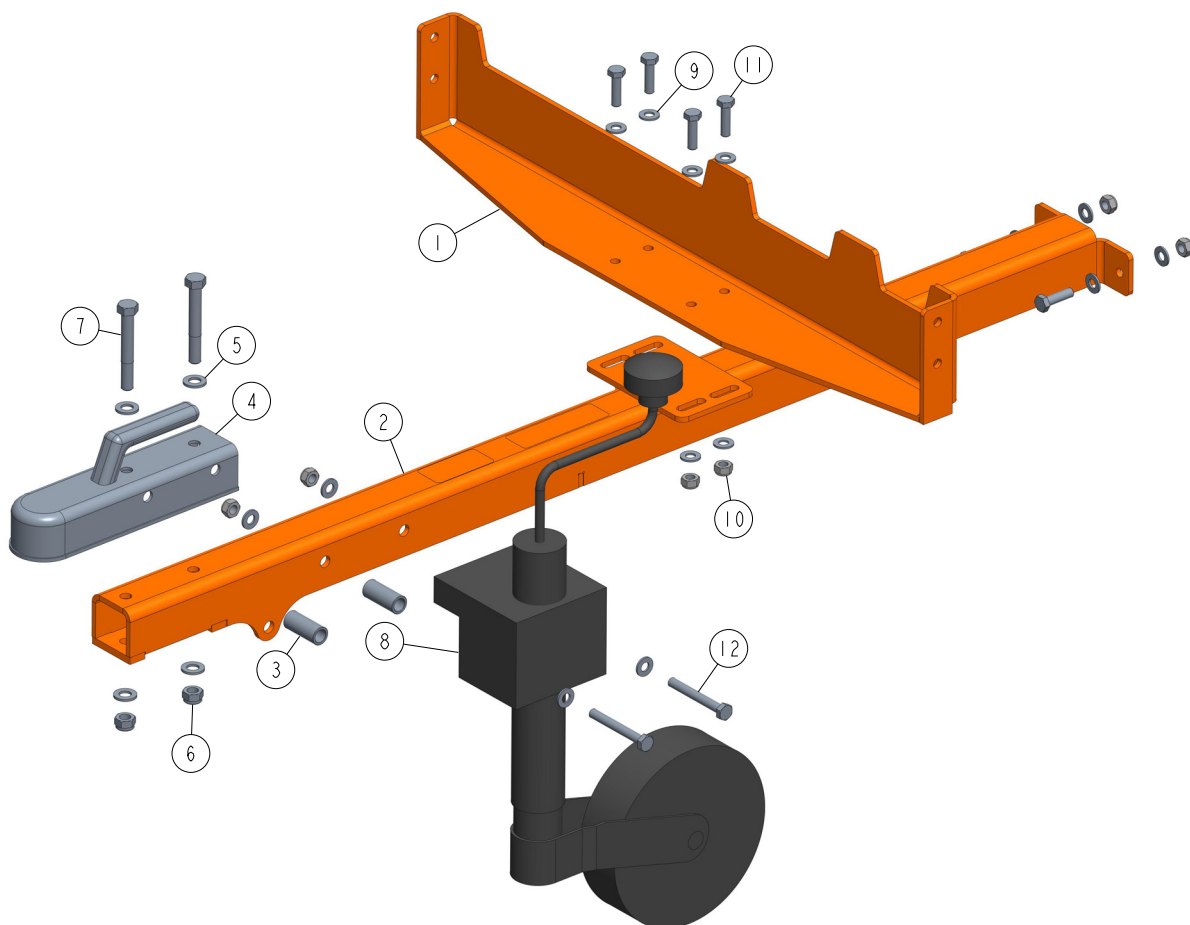

LP.	OPIS (* wskazuje części dostępne jedynie w zespołach)	Nr części	Ilość
-	TRAILER, LX50 EU	607400	1
1	PLATE, HITCH CROSS	600007-1	1
-	HITCH, LX50 EU	607401	1
2	DRAWBAR, LX50	607399-1	1
3	BUSHING, 14/20-62	605823-1	2
4	HITCH, AK7 KW60 (1 224 743)	538520	1
5	WASHER, 13 FLAT ZINC, WASHER, M12 , FLAT	F81056-1	4
6	NUT, M12-8 , HEX, NYLON, ZINC, LOCK	F81034-2	2
7	BOLT, M12X90 8.8 HEX HEAD ZINC	F81004-2	2
8	WHEEL, N48 JOCKEY W/CLAMP (1 222 434+205)	538523	1
9	WASHER, 10.5 FLAT ZINC	F81055-1	16
10	NUT, M10-8-B HEX NYLON ZINC LOCK	F81033-1	8
11	BOLT,M10X35-8.8 HEX HEAD FULL THREAD ZIN	F81003-17	6
12	BOLT, M10 X 80 -8.8- FE/ZN5 HEX HEAD	F81003-50	2

1.7 Accessories - LX50 Trailer



REF	DESCRIPTION (◆ indicates parts available in assemblies only)	PART #	QTY	
-	ACCESSORIES, LX50 TRAILER	610711	1	
1	BRACKET, LX50 TRAILER RAMP	600034-1	2	
2	RAMP, LX50 LOADING	600030-1	2	
-	WINCH, LX50	597818	1	
3	BASE, WINCH	597817-1	1	
4	ARM, WINCH	597815-1	1	
5	WINCH, DWK 35V HAND	534651	1	
6	PIN, LOCK	534657-1	2	
7	PIN, 8 BN914 (BOSSARD 134650) LOCK	F81046-2	4	
8	WASHER, 10.5 FLAT ZINC	F81055-1	10	
9	NUT, M10-8-B HEX NYLON ZINC LOCK	F81033-1	5	
10	BOLT, DIN933-M10X30-8.8-A2E HEX HEAD	F81003-111	5	
11	WASHER, 10.5 FLAT ZINC	F81055-1	24	
12	NUT, M10-8-B HEX NYLON ZINC LOCK	F81033-1	12	
13	BOLT, M10X35-8.8 HEX HEAD FULL THREAD ZIN	F81003-17	12	

1.8 Accessories - LX50 Trailer - USA (140321)

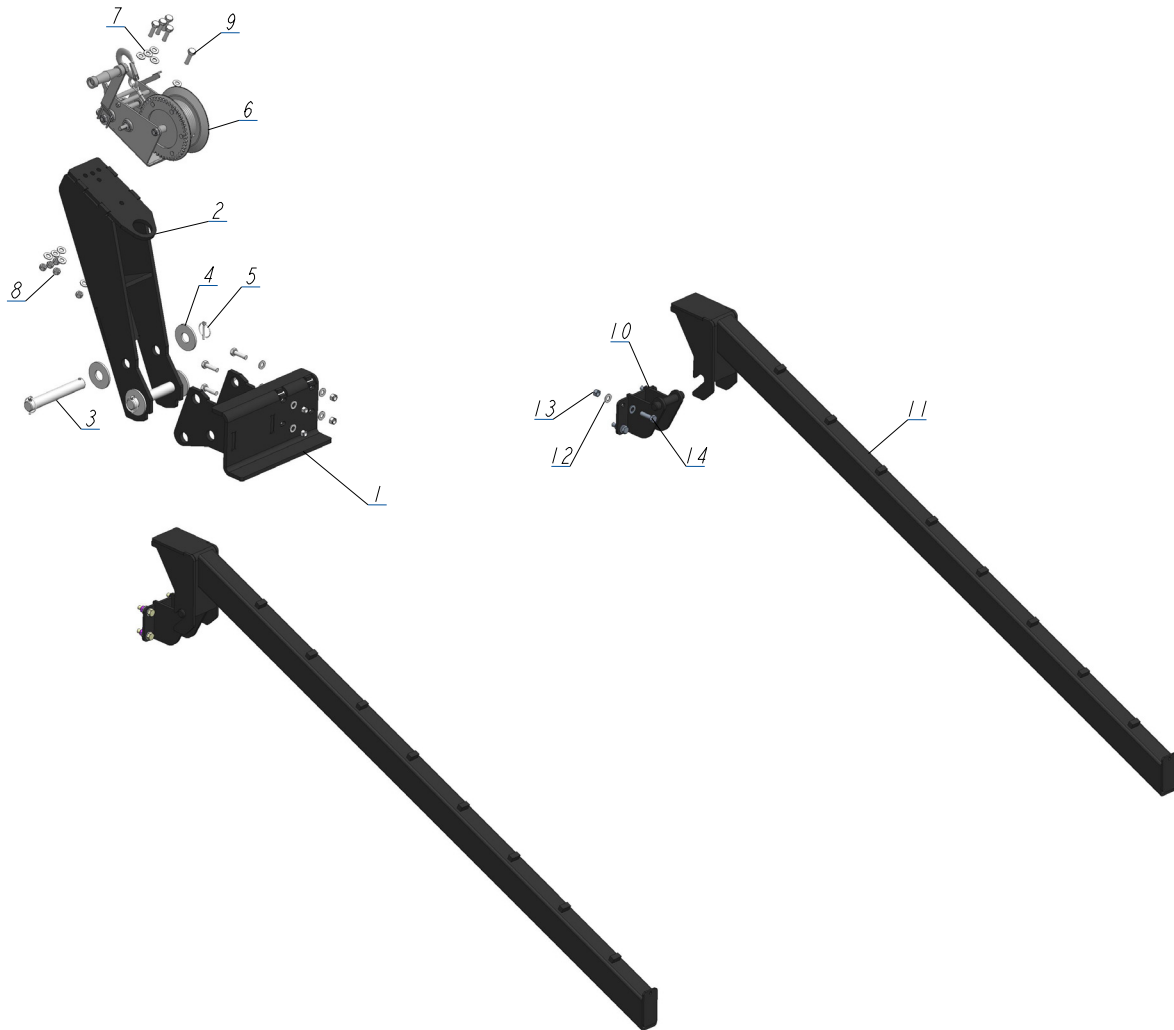

REF	DESCRIPTION (◆ indicates parts available in assemblies only)	PART #	QTY
-	ASSY, LX50 TRAILER ACCESSORIES - USA	140321	1
-	ASSY, WINCH BASE	140310	1
1	WLDMNT, WINCH MOUTING WLDMNT	140314	1
2	WLDMNT, LX50 BASE WINCH	140315	1
3	PART, NEW	140322	2
4	WASHER, 1 ID FLAT	F05011-70	4
5	PIN, 3/16 LINCH	017604	4
6	WINCH, DWK 35V HAND	534651	1
7	WASHER, M10 FLAT SAE	F05011-134	10
8	NUT, M10-1.50 HEX NYL LOCK	F05004-270	5
9	BOLT, M10-1.50 X 35MM HH GR 8.8	F05022-18	5
10	WLDMNT, LOADING RAMP CLAMP	140318	2
11	RAMP WDMT, MANUAL LOG	140151	2
12	WASHER, M10 FLAT SAE	F05011-134	24
13	NUT, M10-1.50 HEX NYL LOCK	F05004-270	12
14	BOLT, M10-1.50 X 35MM HH GR 8.8	F05022-18	12
-	PUSHBAR, LX25	118438	1
-	PUSHBAR, LX55	140250	1

1**Accessories - LX50 Trailer - USA (140321)**

REF	DESCRIPTION (◆ indicates parts available in assemblies only)	PART #	QTY	
-	PUSHBAR, LX50SA (START) - FOR MACHINES MANUFACTURED BEFORE 05.08.2024	140340	1	
-	PUSHBAR, LX50SC (SUPER) - FOR MACHINES MANUFACTURED BEFORE 05.08.2024	140336	1	

1.9 Trailer Improvement Kit - LX50 Trailer

610716_001
610716

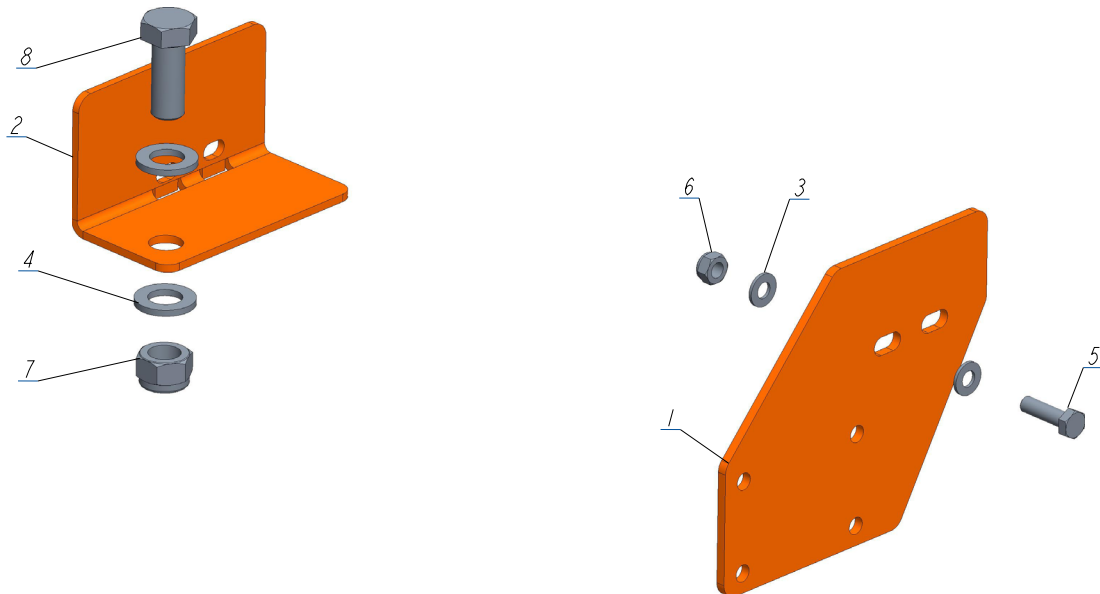

REF	DESCRIPTION (◆ indicates parts available in assemblies only)	PART #	QTY	
-	ASSY, LX50 TRAILER IMPROVEMENT KIT	610716	1	
1	PLATE, TRAILER PLATE LX50	607382-1	1	
2	BRACKET, TRAILER BRACKET LX50	607383-1	1	
3	WASHER, 10.5 FLAT ZINC	F81055-1	2	
4	WASHER, 21 FLAT ZINC	F81059-2	2	
5	BOLT, M10X35-8.8 HEX HEAD FULL THREAD ZIN	F81003-17	1	
6	NUT, M10-8-B HEX NYLON ZINC LOCK	F81033-1	1	
7	NUT, M20-8 DIN985 HEX NYLON ZINC LOCK	F81037-2	1	
8	BOLT, M20X50-8.8-B HEX HEAD FULL THREAD	F81007-17	1	

1.10 Decals - LX50 Trailer

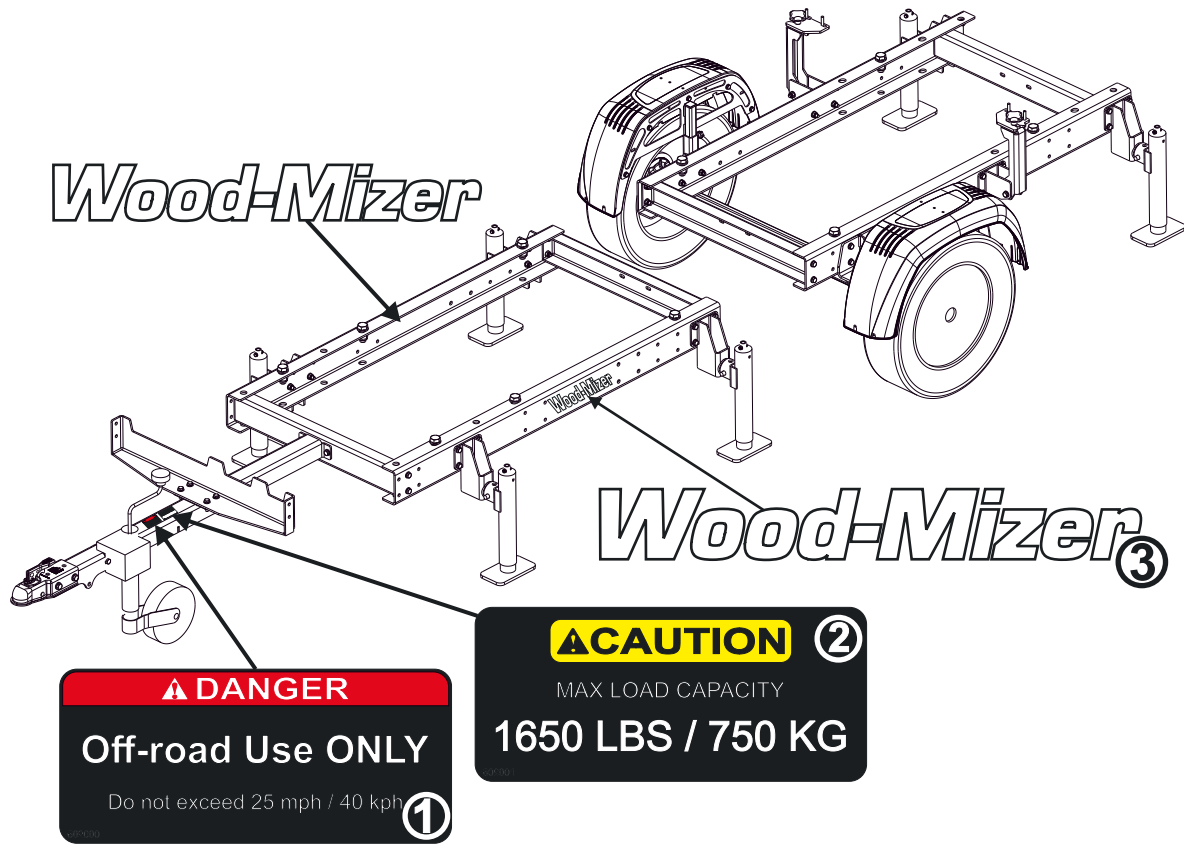

REF	DESCRIPTION (◆ indicates parts available in assemblies only)	PART #	QTY
1	DECAL, OFF-ROAD USE ONLY	609000	1
2	DECAL, MAX LOAD CAPACITY	609001	1
3	DECAL, WOOD-MIZER	609002	2