

Wood-Mizer®

Parts Manual

MP220

rev. A1.00



Safety is our #1 concern! Read and understand all safety information and instructions before operating, setting up or maintaining this machine.

Form #2466

Table of Contents

Section-Page

SECTION 1	GENERAL INFORMATION	1-1
1.1	How To Use the Parts List.....	1-1
1.2	Sample Assembly	1-1
SECTION 2	MP220 MOULDER/PLANER/RIPSAW	2-1
2.1	MP220	2-1
2.2	Guards & Shafts	2-2
2.3	Knives	2-3
2.4	Decals	2-4
2.5	Additional Parts Kit (No. 542491)	2-6
2.6	Wrench Set (No. 535185)	2-7
2.7	Foot Set (No. 536996)	3-8
2.8	Right Guard (No. 546786)	3-9
2.9	Left Guard (No. 546784)	3-10
2.10	Flexible Guard (No. 533729)	4-11
2.11	Top Cover (No. 546613)	4-12
2.12	Knob Assembly (No. 546845)	4-13
2.13	Cast-Iron Table (No. 546737)	4-14
2.14	Press Roller Assembly (No. 533100)	5-15
2.15	Guide Bar Assembly (No. 546715)	5-17
2.16	Feed Assembly (No. 546795)	5-19
2.17	Shaft w/Protective Cover (No. 533581)	6-20
2.18	Drive Shaft Assembly (No. 533580)	7-21
2.19	Slide Bearing Assembly (No. 533520)	8-22
2.20	Up/Down Assembly (No. 546738)	8-23
2.21	Short Acme Screw Assembly (No. 546716)	8-24
2.22	Long Acme Screw Assembly (No. 546718)	8-26
2.23	Round Scale (No. 533676)	9-28
2.24	Handle Assembly (No. 542521)	9-30
2.25	Chain Tensioner (No. 534390)	9-31
2.26	Anti-Kickback Fingers (No. 533125)	9-32
2.27	Cutter Assembly (No. 542485)	9-33
2.28	Main Cutter Assembly (No. 533682)	9-34
2.29	Bearing Housing Assembly (No. 533593)	9-35
2.30	Reinforcing Bracket Assembly (No. 546724)	9-36
2.31	Circular Blade Assembly (No. 546714)	9-37
2.32	Bearing Housing Assembly (No. 542483)	9-38
2.33	Blade w/Mounting Bushing (No. 546627)	9-39
SECTION 3	MP220 MOTORS	10-1
3.1	Electrical Kit, MP220 EH 3x400V CE Motors & Box	10-1
3.2	Feed Drive (No. 533638)	10-3
3.3	Electrical Box Mount Bracket (No. 542487)	10-4

Table of Contents

Section-Page

3.4	Electrical Box (No. 536949)	10-5
3.5	Cutter & Blade Drive Assembly (No. 542486)	10-6

SECTION 1 GENERAL INFORMATION

1.1 How To Use the Parts List

- Use the index above to locate the assembly that contains the part you need.
- Go to the appropriate section and locate the part in the illustration.
- Use the number pointing to the part to locate the correct part number and description in the table.
- Parts shown indented under another part are included with that part.
- Parts marked with a diamond (◆) are only available in the assembly listed above the part.

See the sample table below. Sample Part #A01111 includes part F02222-2 and subassembly A03333. Subassembly A03333 includes part S04444-4 and subassembly K05555. The diamond (◆) indicates that S04444-4 is not available except in subassembly A03333. Subassembly K05555 includes parts M06666 and F07777-77. The diamond (◆) indicates M06666 is not available except in subassembly K05555.

1.2 Sample Assembly				
REF.	DESCRIPTION (◆ Indicates Parts Available In Assemblies Only)	PART #	QTY	
	Sample Assembly, Complete (Includes All Indented Parts Below)	A01111	1	
1	Sample Part	F02222-22	1	
	Sample Subassembly (Includes All Indented Parts Below)	A03333	1	
2	Sample Part (◆ Indicates Part Is Only Available With A03333)	S04444-4	1	◆
	Sample Subassembly (Includes All Indented Parts Below)	K05555	1	
3	Sample Part (◆ Indicates Part Is Only Available With K05555)	M06666	2	◆
4	Sample Part	F07777-77	1	

To Order Parts:

- From Europe call our European Headquarters and Manufacturing Facility in Kolo, Poland at **+48-63-2626000**. From the continental U.S., call our toll-free Parts hotline at **1-800-525-8100**. Have your customer number, vehicle identification number, and part numbers ready when you call. From other international locations, contact the Wood-Mizer distributor in your area for parts.

Office Hours:

Country	Monday - Friday	Saturday	Sunday
Poland	7-15	Closed	Closed
US	8 a.m.- 5 p.m.	8 a.m.- 12 p.m.	Closed



CAUTION! It is strongly recommended that only original spare parts be used.

SECTION 2 MP220 MOULDER/PLANER/RIPSAW

2.1 MP220

MP220EH3S_001
MP220EH3S_MANUAL

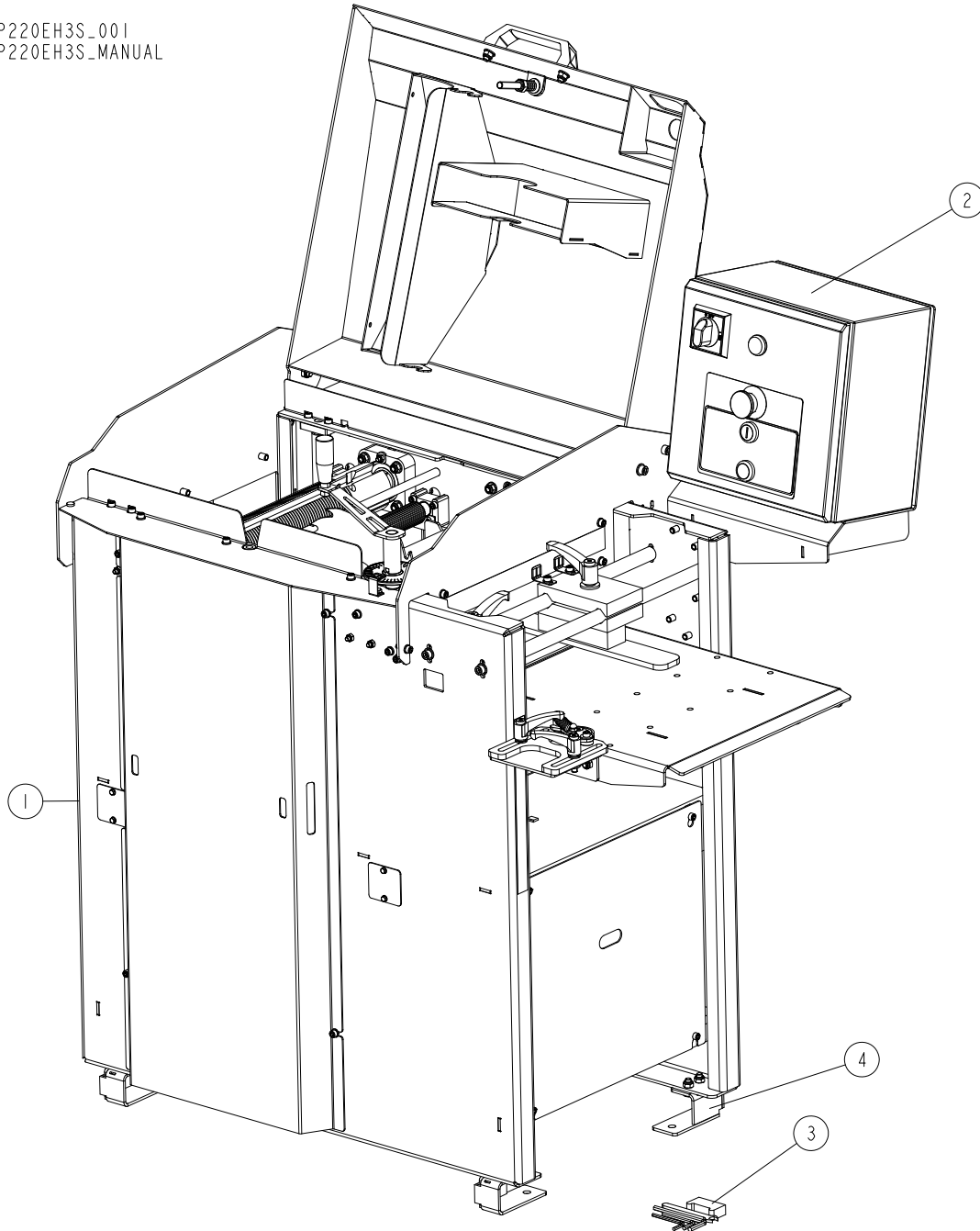

REF.	DESCRIPTION (* indicates parts available in assemblies only)	PART #	QTY
-	MOULDER/PLANER/RIPSAW, MP220EH3S		1
1	MP220 - MECHANICAL ASSEMBLY	542500	1
2	ELECTRICAL KIT, MP220EH 3X400V CE MOTORS & BOX See Section 3.1	545712	1
3	PARTS KIT, MP220 ADDITIONAL See Section 2.5	542491	1
4	FOOT SET See Section 2.7	536996	1

2.2 Guards & Shafts

542500-002
542500-MANUAL

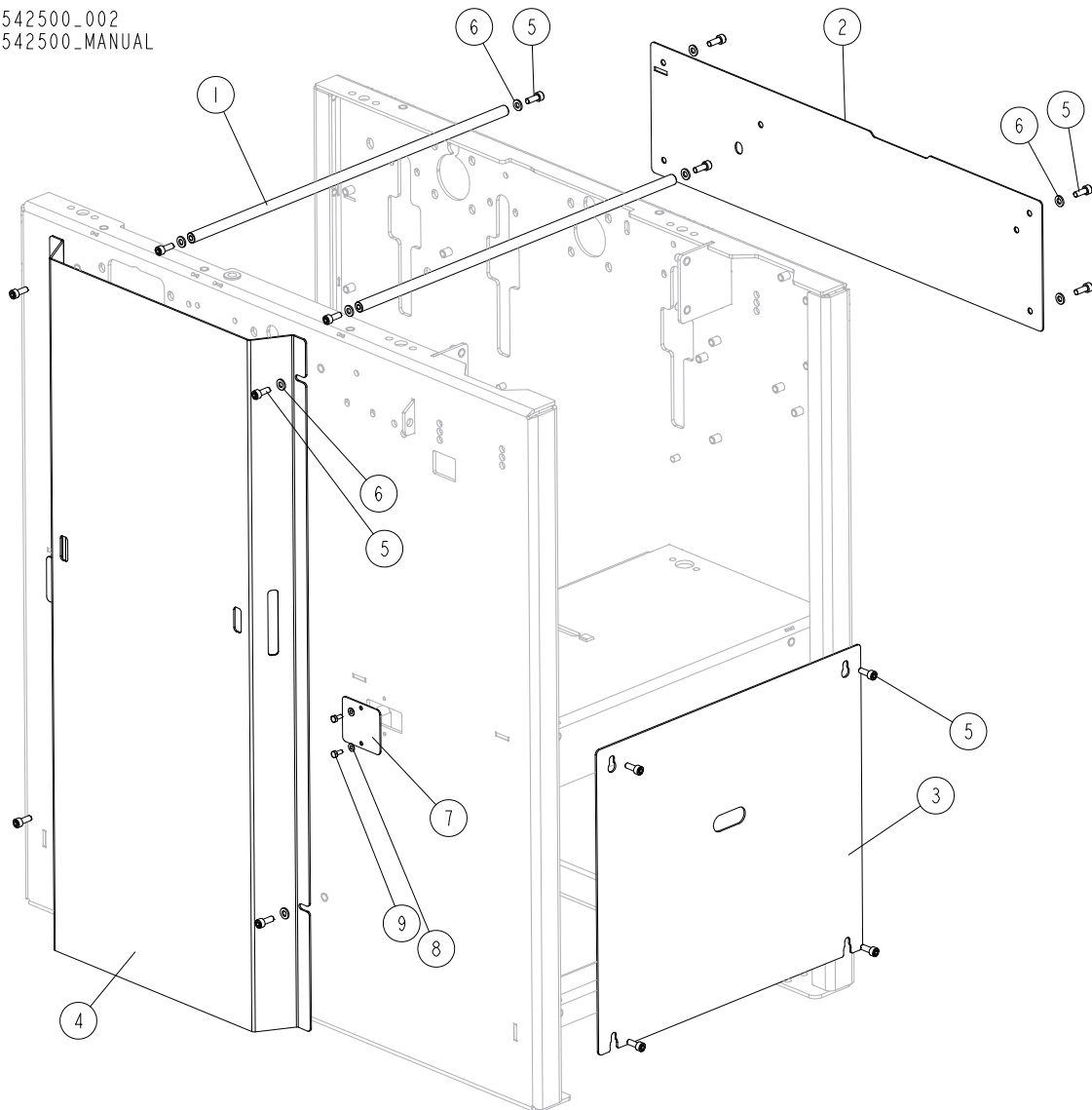

REF.	DESCRIPTION (* indicates parts available in assemblies only)	PART #	QTY
1	SHAFT	533092-1	2
2	PLATE, COVER	546626-1	1
3	COVER I	546648-1	2
4	GUARD, BELT	546625-1	1
5	SCREW, M6X16 8.8 HEX SOCKET HEAD CAP ZINC	F81001-21	20
6	WASHER, 6.4 FLAT ZINC	F81053-1	10
7	COVER, INSPECTION WINDOW	536995-1	4
8	WASHER, 4.3 FLAT ZINC	F81051-2	8
9	BOLT, M4X10 DIN 933/ISO 4017 (A2) STAINLESS STEEL	F81000-27	8

2.3 Knives

542500_003
542500_MANUAL

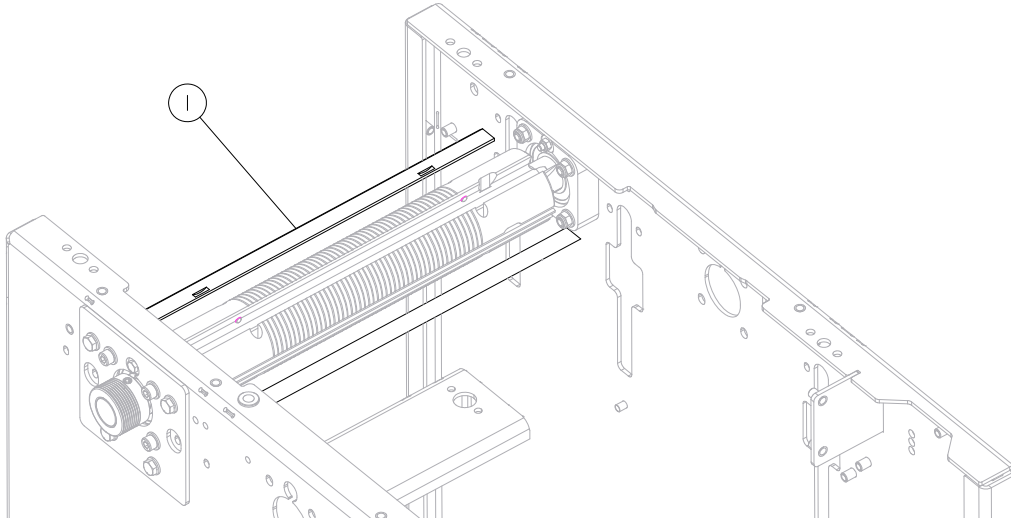

REF.	DESCRIPTION (* indicates parts available in assemblies only)	PART #	QTY
-	KNIFE SET, PLANING	241-050	1
1	TPK410.20HS	TPK41020HS	2

2.4 Decals

MP220EH3S_002
MP220EH3S_MANUAL

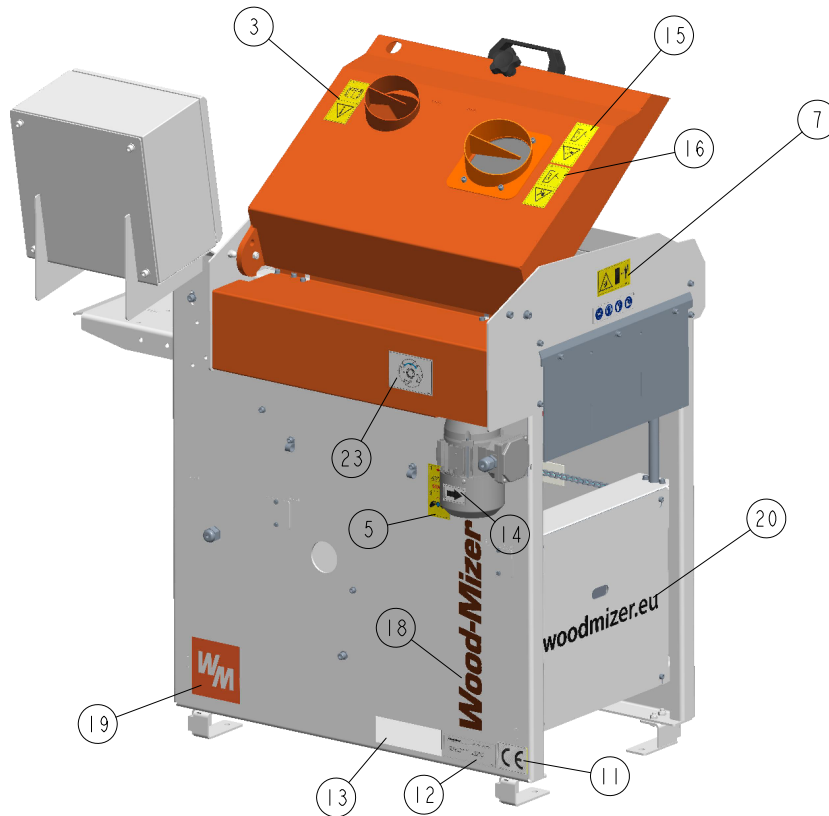
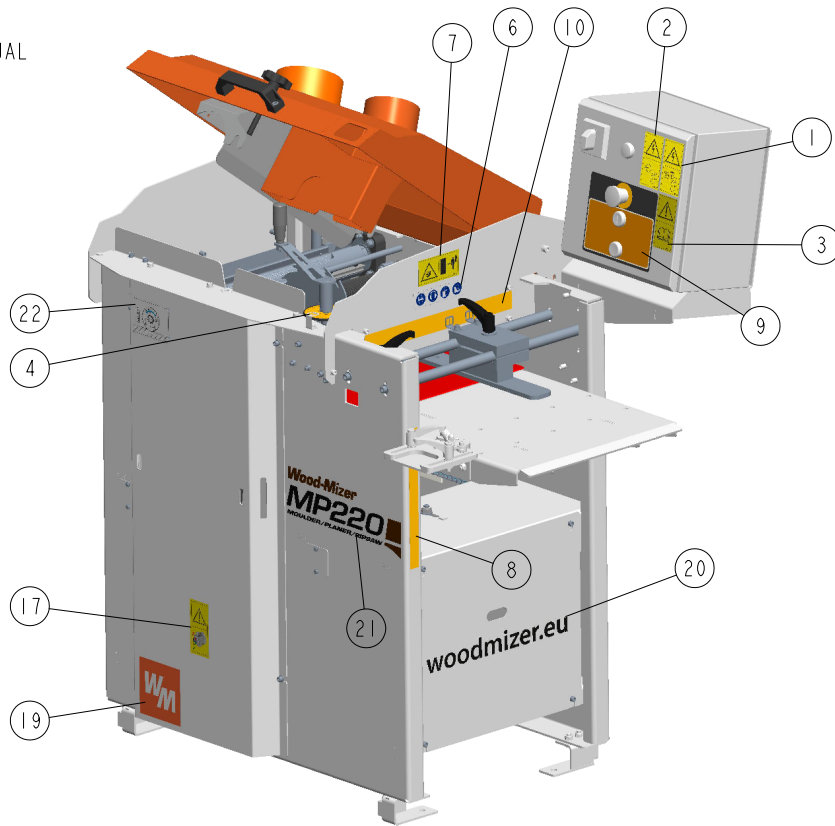

REF.	DESCRIPTION (* indicates parts available in assemblies only)	PART #	QTY
-	DECAL KIT, MP220	553362	1
1	DECAL, REMOVE THE PLUG BEFORE OPENING THE ELECTRICAL BOX (PICTOGRAM)	096319	1
2	DECAL, HAZARDOUS VOLTAGE INSIDE THE ELECTRICAL BOX (PICTOGRAM)	096316	1
3	DECAL, "READ THE OPERATOR'S MANUAL"	096317	2
4	DECAL, MP200 ROUND SCALE	533577	1
5	DECAL, "USE THE CONTINUOUSLY VARIABLE TRANSMISSION WHEN THE FEED IS TURNED ON" (PICTOGRAM)	535252	1
6	DECAL - WARNING PICTOGRAMS	535402	2
7	DECAL, "KEEP A SAFE DISTANCE" PICTOGRAM	099221H	2
8	SCALE, MP220 TABLE HEIGHT	546600	1
9	DECAL, ELECTRICAL BOX	534765	1
10	SCALE, MP220 CUTTING WIDTH	546599	1
11	DECAL, CE CERTIFIED SAWMILL - SMALL	P85070	1
12	DECAL, EUROPEAN HEADQUARTER ADDRESS	015841	1
13	DECAL, VIN	VIN	1
14	DECAL, MOTOR REVOLUTIONS DIRECTION	S20097	1
15	DECAL, "CLOSE GUARDS AND COVERS BEFORE OPERATING"	099220	1
16	DECAL, HAND INJURY HAZARD (PICTOGRAM)	524993	1
17	DECAL, CORRECT MOTOR REVOLUTIONS DIRECTION (PICTOGRAM)	553360	1
18	DECAL, "WOOD-MIZER"	553366	1
19	DECAL, "WM"	553364	2
20	DECAL, "WOODMIZER.EU"	553365	2
21	DECAL, MP220 MACHINE TYPE	553361	1
22	DECAL, MP200 MAXIMUM PLANING THICKNESS	535155	1
23	DECAL, MP160 SHAFT ROTATION DIRECTION	536401	1

2.5 Additional Parts Kit (No. 542491)

542491_001
542491_MANUAL

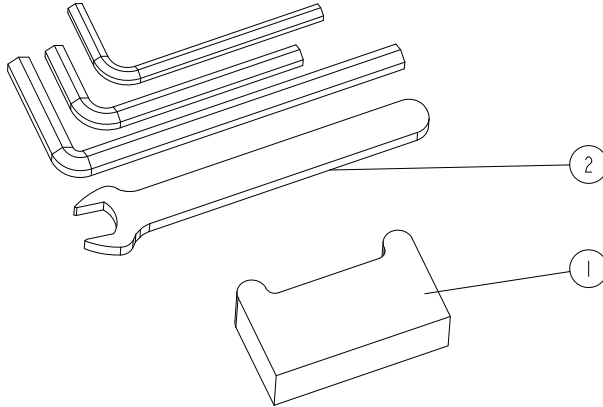

REF.	DESCRIPTION (* indicates parts available in assemblies only)	PART #	QTY	
-	PARTS KIT, MP220 ADDITIONAL	542491	1	
1	TOOL, KNIFE SETTING	534770	1	
2	WRENCH SET, MP160 See Section 2.6	535185	1	

2.6 Wrench Set (No. 535185)

535185_001
535185_MANUAL

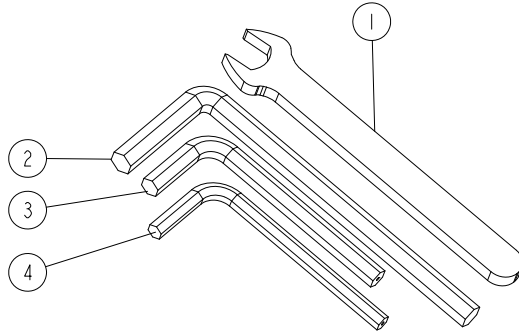

REF.	DESCRIPTION (* indicates parts available in assemblies only)	PART #	QTY
-	WRENCH SET, MP160	535185	1
1	WRENCH, 10 OPEN-END	541315	1
2	WRENCH, 6 MM ALLEN	535186	1
3	WRENCH, 5 ALLEN	092915	1
4	WRENCH, 4MM ALLEN	093368	1

2.7 Foot Set (No. 536996)

536996_001
536996_MANUAL



REF.	DESCRIPTION (* indicates parts available in assemblies only)	PART #	QTY
-	FOOT SET	536996	1
1	FOOT	535828-1	4
2	BOLT, M8X20MM, HEX HEAD,GR 5.8 ZINC,	F81002-4	4
3	NUT,M8-8-B,HEX,NYLON LOCK ZINC, NUT, M8-8-B HEX NYLON ZINC LOCK	F81032-2	4

2.8 Right Guard (No. 546786)

546786_001
546786_MANUAL

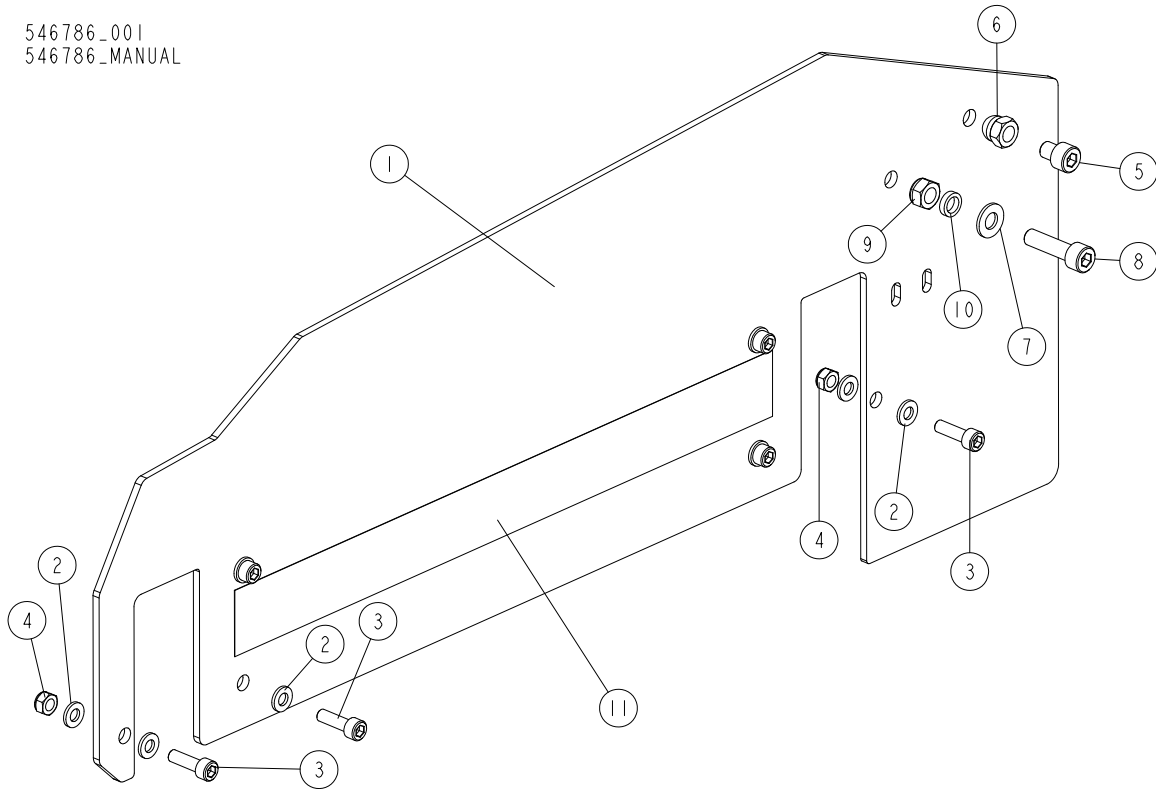

REF.	DESCRIPTION (* indicates parts available in assemblies only)	PART #	QTY
-	GUARD, COMPLETE RIGHT	546786	1
1	PLATE, RIGHT GUARD	546616-1	1
2	WASHER, 6.4 FLAT ZINC	F81053-1	8
3	SCREW, M6X20 8.8 HEX SOCKET HEAD CAP ZINC	F81001-22	6
4	NUT, M6-8-B HEX NYLON ZINC LOCK	F81031-2	2
5	SCREW, M8X10-8.8 HEX SOCKET HEAD CAP ZINC	F81002-32	1
6	NUT, M8 ZINC DOMED CAP	F81033-25	1
7	WASHER, 8.4 FLAT ZINC	F81054-1	1
8	SCREW, M8X30 8.8 HEX SOCKET HEAD CAP ZINC	F81002-31	1
9	NUT, M8-8-B HEX NYLON ZINC LOCK	F81032-2	1
10	BUSHING, SPACER	533674	1
11	SCALE, MP220 CUTTING WIDTH	546599	1

2.9 Left Guard (No. 546784)

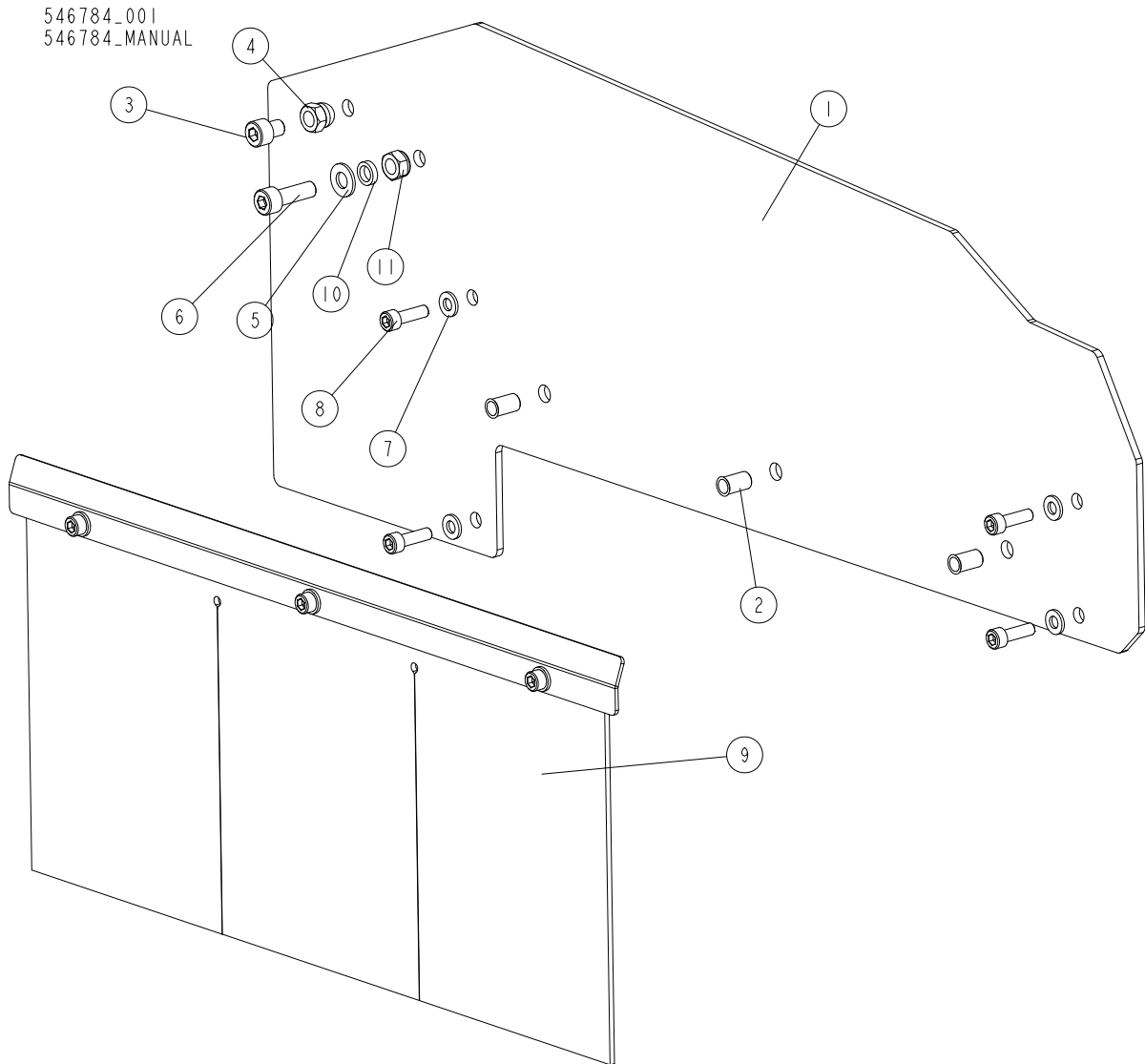

REF.	DESCRIPTION (* indicates parts available in assemblies only)	PART #	QTY
-	GUARD, COMPLETE LEFT	546784	1
1	PLATE, LEFT GUARD	546617-1	1
2	NUT, M6 1.5-4.0 MIN MTRG ZINC STEEL RIVET	F81031-13	3
3	SCREW, M8X10-8.8 HEX SOCKET HEAD CAP ZINC	F81002-32	1
4	NUT, M8 ZINC DOMED CAP	F81033-25	1
5	WASHER, 8.4 FLAT ZINC	F81054-1	1
6	SCREW, M8X25 -8.8 HEX SOCKET HEAD CAP ZINC	F81002-21	1
7	WASHER, 6.4 FLAT ZINC	F81053-1	4
8	SCREW, M6X20 8.8 HEX SOCKET HEAD CAP ZINC	F81001-22	4
9	GUARD, COMPLETE FLEXIBLE See Section 2.10	533729	1
10	BUSHING, SPACER	533674	1
11	NUT, M8-8-B HEX NYLON ZINC LOCK	F81032-2	1

2.10 Flexible Guard (No. 533729)

533729_001
533729_MANUAL

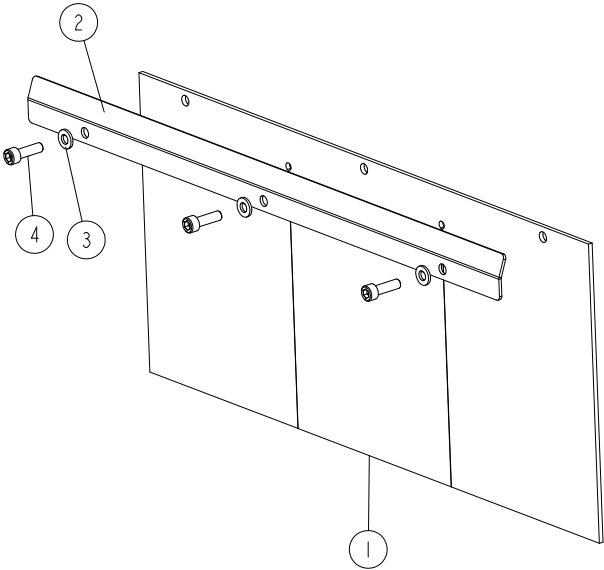

REF.	DESCRIPTION (* indicates parts available in assemblies only)	PART #	QTY	
-	GUARD, COMPLETE FLEXIBLE	533729	1	
1	GUARD, FLEXIBLE	533083	1	
2	BRACKET, FLEXIBLE GUARD	533082-1	1	
3	WASHER, 6.4 FLAT ZINC	F81053-1	3	
4	SCREW, M6X20 8.8 HEX SOCKET HEAD CAP ZINC	F81001-22	3	

2.11 Top Cover (No. 546613)

546613_001_A
546613_MANUAL

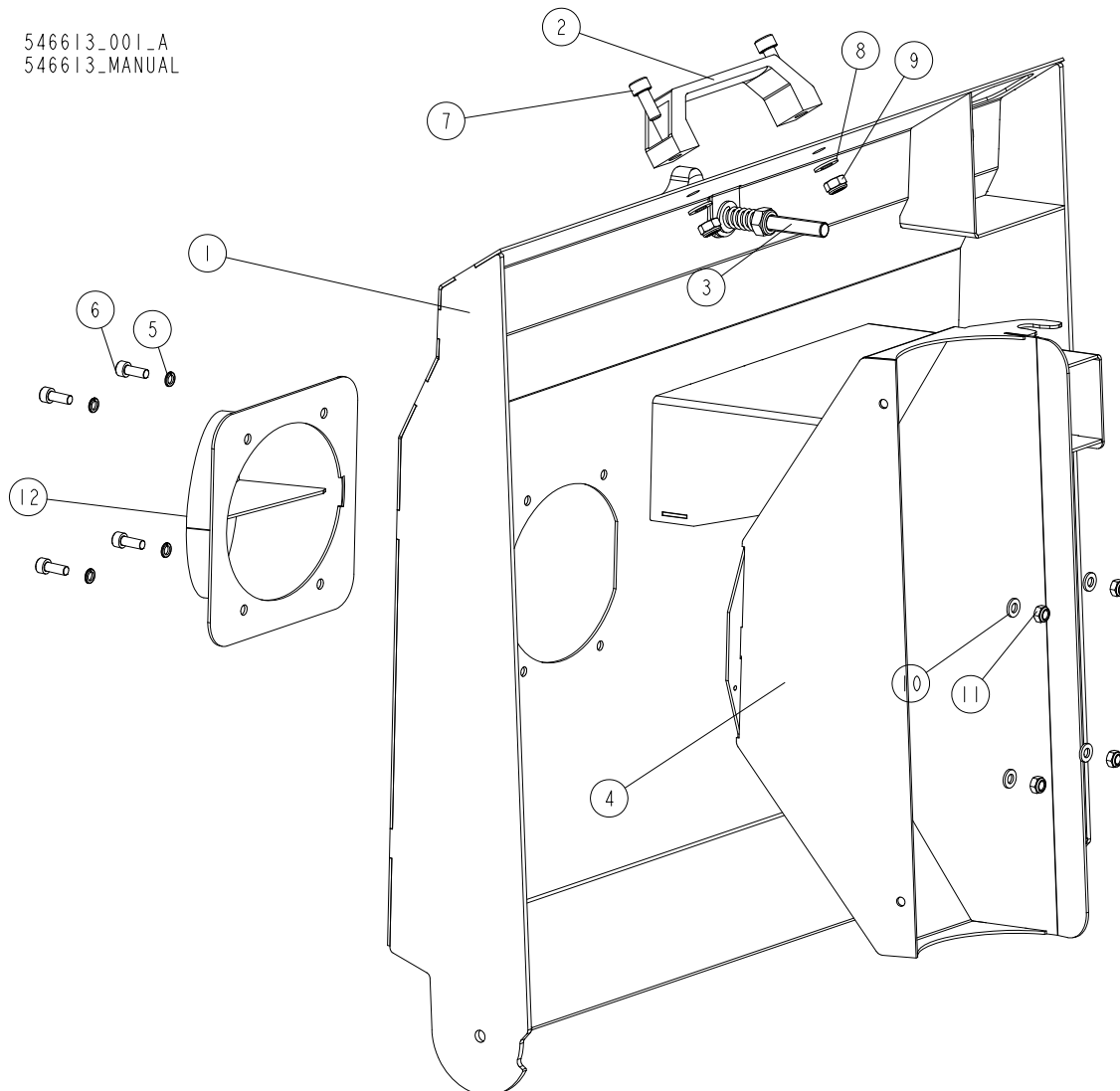

REF.	DESCRIPTION (* indicates parts available in assemblies only)	PART #	QTY
-	COVER, COMPLETE TOP	546613	1
1	COVER WELDMENT - COMPLETE	546614-1	1
2	U-HANDLE	533506	1
3	KNOB ASSEMBLY, STAR See Section 2.12	546845	1
4	OUTLET WELDMENT, SAWDUST	546608-1	1
5	WASHER, Z 6.1 SPLIT LOCK ZINC	F81053-3	4
6	SCREW, M6X16 8.8 HEX SOCKET HEAD CAP ZINC	F81001-21	4
7	SCREW, M8X20-8.8 HEX SOCKET HEAD CAP ZINC	F81002-30	2
8	WASHER, 8.4 FLAT ZINC	F81054-1	2
9	NUT, M8-8-B HEX NYLON ZINC LOCK	F81032-2	2
10	WASHER, 6.4 FLAT ZINC	F81053-1	4
11	NUT, M6-8-B HEX NYLON ZINC LOCK	F81031-2	4
12	CONNECTOR, SAWDUST OUTLET	546906-1	1

2.12 Knob Assembly (No. 546845)

546845_001
546845_MANUAL

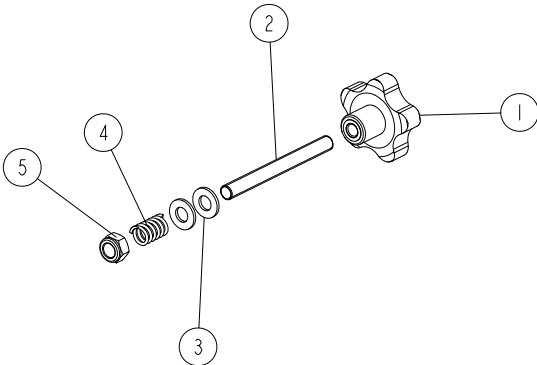

REF.	DESCRIPTION (* indicates parts available in assemblies only)	PART #	QTY
-	KNOB ASSEMBLY, STAR	546845	1
1	KNOB, GW M10 STAR	546844	1
2	ROD, M10X100 THREADED	546843	1
3	WASHER, 10.5 FLAT ZINC	F81055-1	2
4	SPRING	533677	1
5	NUT, M10-8-B HEX NYLON ZINC LOCK	F81033-1	1

2.13 Cast-Iron Table (No. 546737)

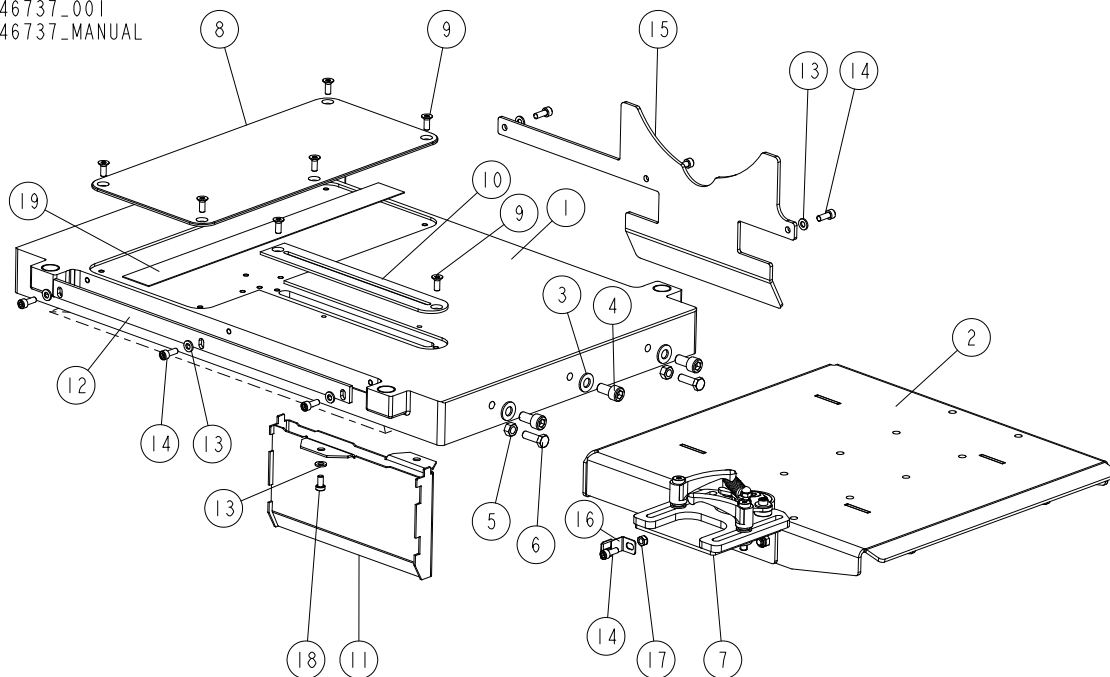
546737_001
546737_MANUAL

REF.	DESCRIPTION (* indicates parts available in assemblies only)	PART #	QTY
-	TABLE ASSEMBLY, CAST IRON	546737	1
1	TABLE, MP220 CAST IRON	546713-1	1
2	TABLE WELDMENT, INFEED	533665-1	1
3	WASHER, 10.5 FLAT ZINC	F81055-1	3
4	SCREW, M10X20 8.8 HEX SOCKET HEAD CAP ZINC	F81003-108	3
5	NUT, M8-8-B HEX ZINC	F81032-1	2
6	BOLT, M8X25-8.8-B HEX HEAD FULL THREAD ZINC	F81002-5	2
7	PRESS ROLLER ASSEMBLY See Section 2.14	533100	1
8	PLATE, SLIDE	546633	1
9	SCREW, M6X16-10.9 DIN7991 ISO10642 FLAT SOCKET HEAD CAP ZINC	F81001-55	7
10	PLATE, W/SLOT	546632	1
11	CHUTE WELDMENT, SAWDUST	546647-1	1
12	BAR	546835-1	1
13	WASHER, 6.4 FLAT ZINC	F81053-1	8
14	SCREW, M6X16 8.8 HEX SOCKET HEAD CAP ZINC	F81001-21	7
15	PLATE, TABLE (1)	546638-1	1
16	INDICATOR, TABLE HEIGHT SCALE	533099	1
17	NUT, M6-8-B HEX NYLON ZINC LOCK	F81031-2	1
18	SCREW, M6X12-10.9 DIN 7984 HEX SOCKET THIN HEAD CAP	F81001-80	2
19	STRIP, DOUBLE-SIDED ADHESIVE	535159	1

2.14 Press Roller Assembly (No. 533100)

533100_001
533100_MANUAL

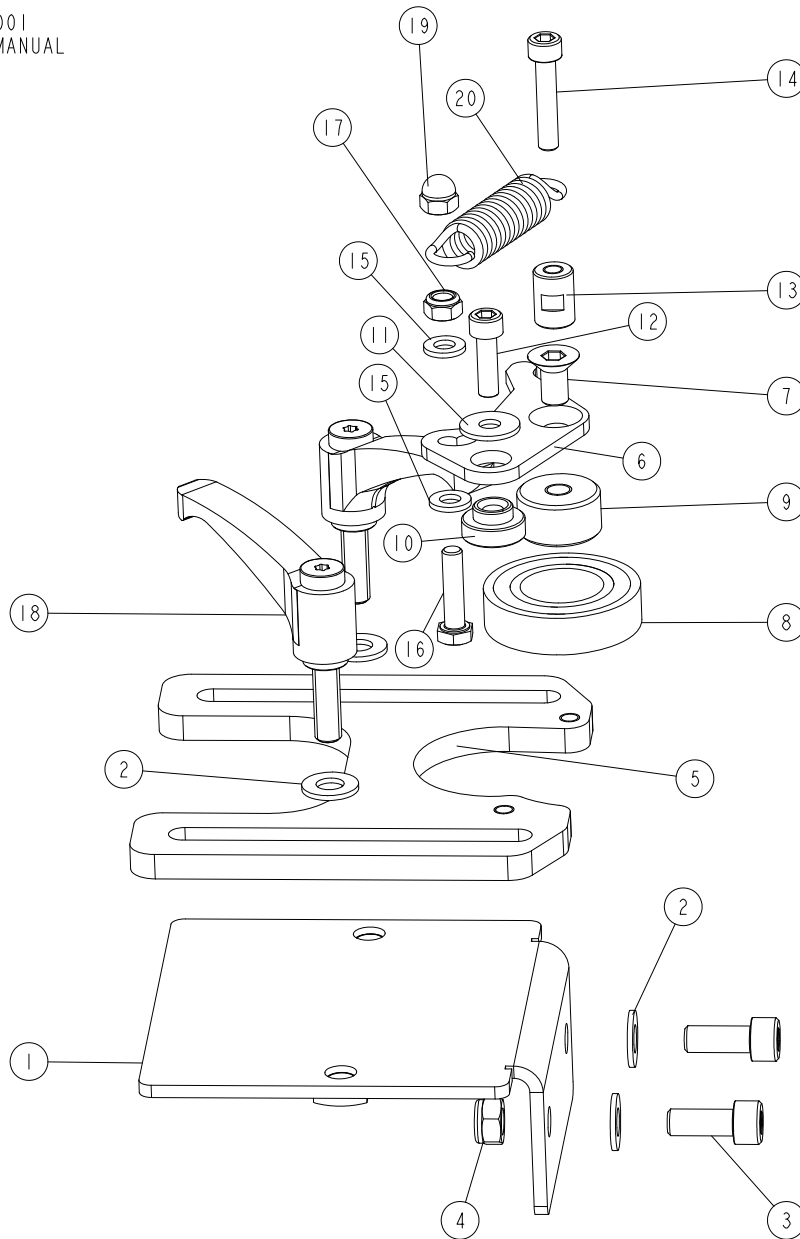

REF.	DESCRIPTION (* indicates parts available in assemblies only)	PART #	QTY
-	ROLLER ASSEMBLY, PRESS	533100	1
1	PLATE WELDMENT, MOUNT	533101-1	1
2	WASHER, 8.4 FLAT ZINC	F81054-1	4
3	SCREW, M8X20-8.8 HEX SOCKET HEAD CAP ZINC	F81002-30	2
4	NUT, M8-8-B HEX NYLON ZINC LOCK	F81032-2	2
5	PLATE, ADJUSTMENT	533103-1	1
6	BRACKET, BEARING MOVABLE	533525-1	1
7	SCREW, M8X16 FE/ZN5 7991 10.9 FLAT SOCKET HEAD CAP	F81002-82	1
8	BEARING, 6005 2RS	089652	1
9	BUSHING, M8/25-13.5 ZINC-PLATED	533529-1	1
10	BUSHING, 6.2/12-10 FLANGED 19-6	533632	1

REF.	DESCRIPTION (* indicates parts available in assemblies only)	PART #	QTY	
11	WASHER, 6.5 SPECIAL FLAT ZINC	F81053-11	1	
12	SCREW, M6X20 8.8 HEX SOCKET HEAD CAP ZINC	F81001-22	1	
13	BUSHING, M6/12-17 ZINC-PLATED	533633-1	1	
14	SCREW, M6X30-8.8 HEX SOCKET HEAD CAP ZINC	F81001-42	1	
15	WASHER, 6.4 FLAT ZINC	F81053-1	2	
16	BOLT, M6X25 -8.8 HEX HEAD FULL THREAD ZINC	F81001-3	1	
17	NUT, M6-8-B HEX NYLON ZINC LOCK	F81031-2	1	
18	LEVER, ERZ.63P-M8X25 ADJUSTABLE	533591	2	
19	NUT, DIN 1587 M6 FE/ZN5 HEX DOMED CAP	F81031-18	1	
20	SPRING, 15X65X2.5 EXTENSION	533571	1	

2.15 Guide Bar Assembly (No. 546715)

546715_001
546715_MANUAL

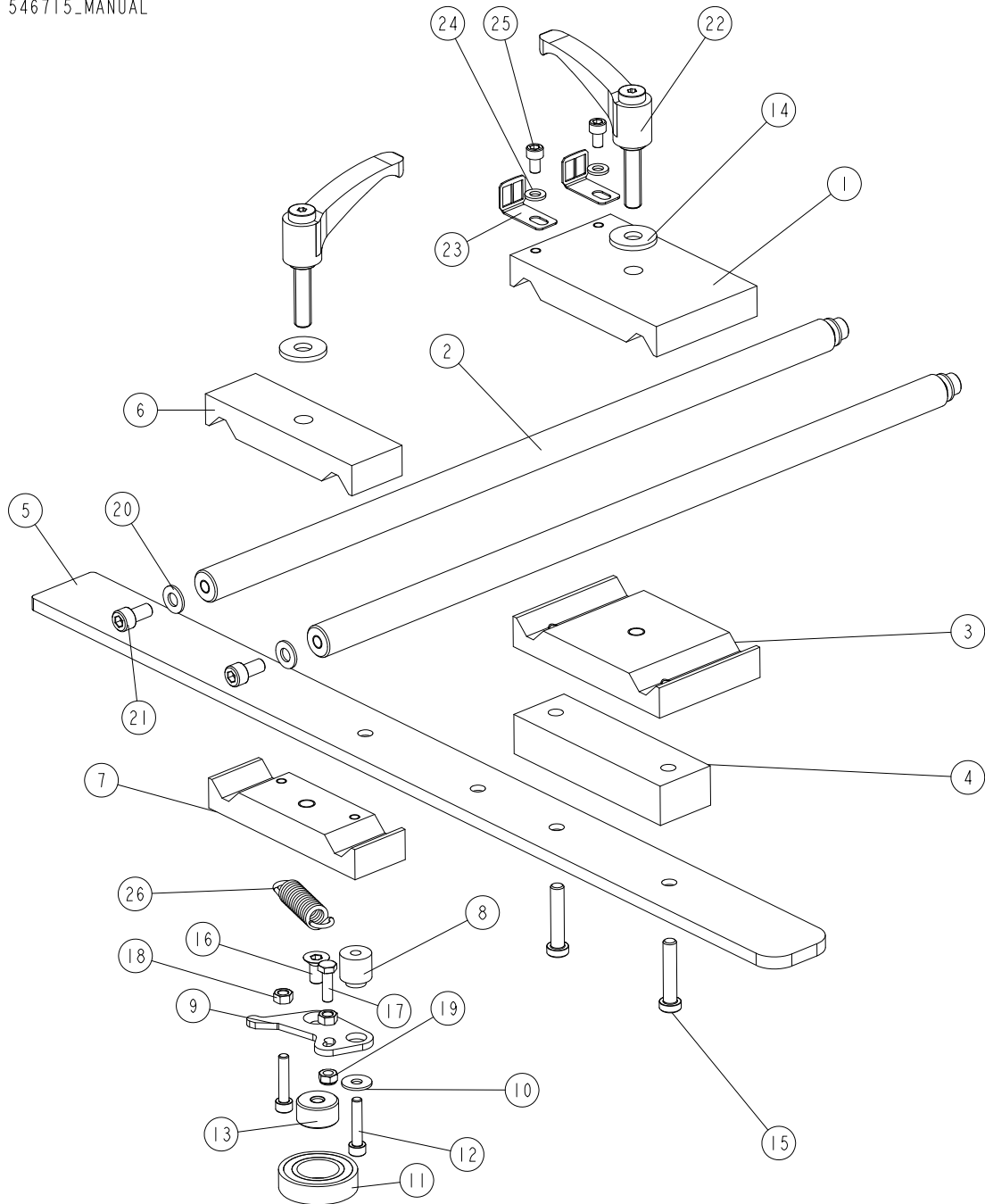

REF.	DESCRIPTION (* indicates parts available in assemblies only)	PART #	QTY
-	BAR ASSEMBLY, GUIDE	546715	1
1	BRACKET, ROD MOUNT - UPPER	533530-1	1
2	ROD, N20X494	533531-1	2
3	BRACKET, ROD MOUNT - LOWER	533523-1	1
4	BLOCK, 26X40X130 CONNECTION	533522-1	1
5	BAR, GUIDE	546894-1	1
6	PLATE, BASIC UPPER	533527-1	1

REF.	DESCRIPTION (* indicates parts available in assemblies only)	PART #	QTY
7	PLATE, BASIC LOWER	533526-1	1
8	BUSHING, 6.2/19-20.3 12-4.3	533528	1
9	BRACKET, BEARING MOVABLE	533525-1	1
10	WASHER, 6.5 SPECIAL FLAT ZINC	F81053-11	1
11	BEARING, 6005 2RS	089652	1
12	SCREW, M6X30-8.8 HEX SOCKET HEAD CAP ZINC	F81001-42	2
13	BUSHING, M8/25-13.5 ZINC-PLATED	533529-1	1
14	WASHER, 10.5 SPECIAL FLAT ZINC	F81055-6	2
15	SCREW, M8X40-8.8-FE/ZN5 DIN 7984 ISO 14580 HEX SOCKET THIN HEAD CAP	F81002-81	2
16	SCREW, M8X16-10.9 FE/ZN5 DIN7991 FLAT SOCKET HEAD CAP	F81002-82	1
17	BOLT, M6X20 8.8 HEX HEAD FULL THREAD ZINC	F81001-2	1
18	NUT, M6 8 HEX ZINC	F81031-1	2
19	NUT, M6-8-B HEX NYLON ZINC LOCK	F81031-2	1
20	WASHER, 8.4 FLAT ZINC	F81054-1	4
21	SCREW, M8X16-8.8 HEX SOCKET HEAD CAP ZINC	F81002-39	4
22	LEVER, ERZ.78 P-M10X40 ADJUSTABLE	533536	2
23	INDICATOR, SCALE	533098	2
24	WASHER, 6.4 FLAT ZINC	F81053-1	2
25	SCREW, M6X10 8.8 HEX SOCKET HEAD CAP ZINC	F81001-12	2
26	SPRING, 15X65X2.5 EXTENSION	533571	1

2.16 Feed Assembly (No. 546795)

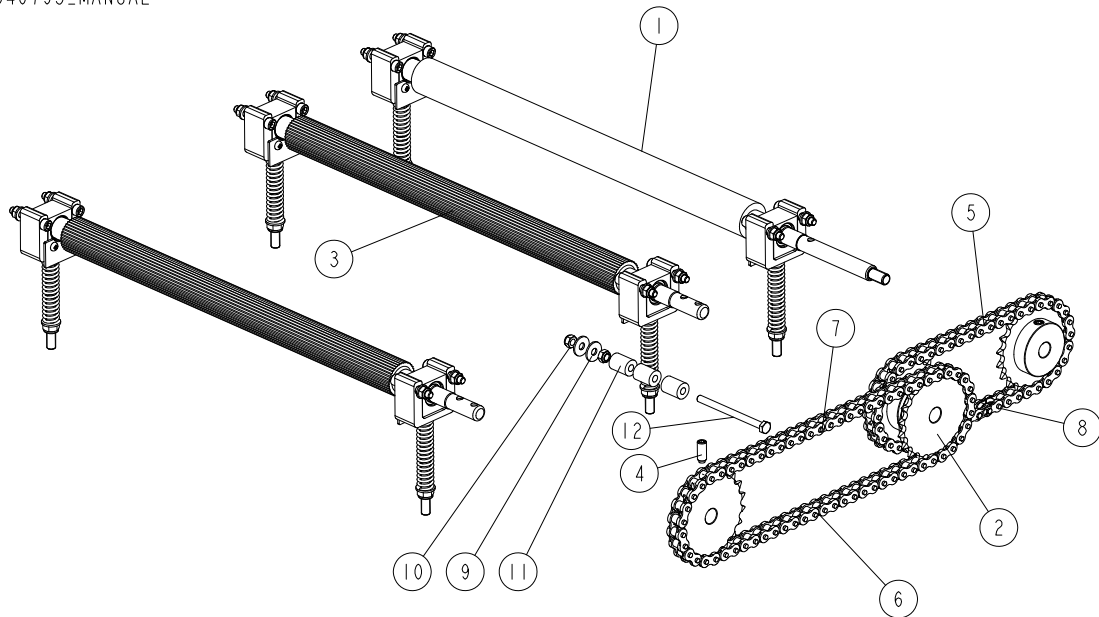
546795_001
546795_MANUAL

REF.	DESCRIPTION (* indicates parts available in assemblies only)	PART #	QTY
-	FEED ASSEMBLY, MP220	546795	1
1	SHAFT ASSEMBLY, W/PROTECTIVE COVER See Section 2.17	533581	1
2	SPROCKET, Z=20; 1/2"X 3/16" (CHAIN 083-1)	533109	4
3	SHAFT ASSEMBLY, DRIVE See Section 2.18	533580	2
4	SCREW, M8X20 -45H- PN-EN-ISO 4028 ; DIN915 HEX SOCKET SET W/DOG POINT	F81002-77	4
5	CHAIN, 083-1; P=1/2"; LENGTH L=606 MM (43-LINK)	546796	1
6	CHAIN, 083-1; P=1/2"; LENGTH L=847 MM (63-LINK)	546797	1
7	LINK, 083-1 MASTER	533128	2
8	LINK, 083-1 HALF	533129	1
9	WASHER, 6.5 SPECIAL FLAT ZINC	F81053-11	2
10	NUT, M6-8-B HEX NYLON ZINC LOCK	F81031-2	2
11	BUSHING, SPACER	R80671-6	3
12	BOLT, M6X80 8.8 HEX HEAD FULL THREAD ZINC	F81001-61	1

2.17 Shaft w/Protective Cover (No. 533581)

533581_001_A
533581_MANUAL

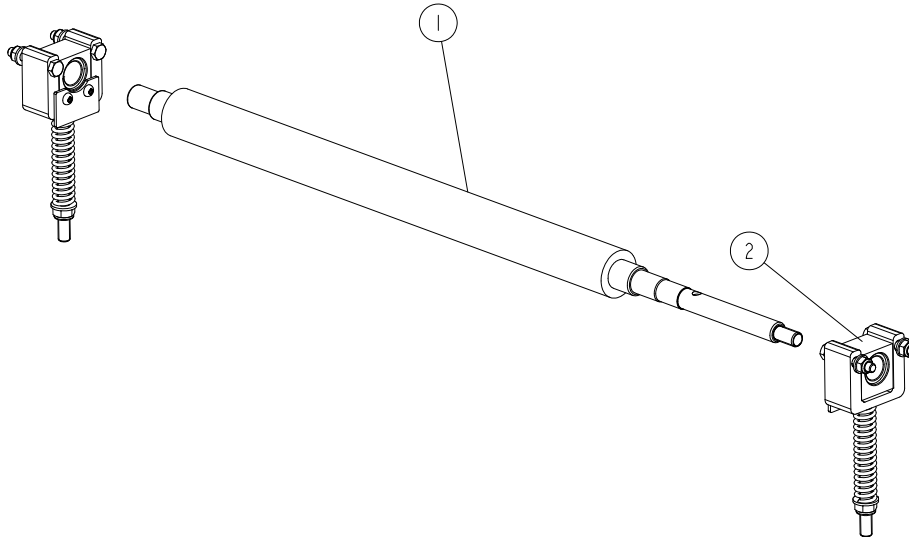

REF.	DESCRIPTION (* indicates parts available in assemblies only)	PART #	QTY	
-	SHAFT ASSEMBLY, W/PROTECTIVE COVER	533581	1	
1	SHAFT W/PROTECTIVE COVER	533512	1	
2	BEARING ASSEMBLY, SLIDE See Section 2.19	533520	2	

2.18 Drive Shaft Assembly (No. 533580)

533580_001_A
533580_MANUAL

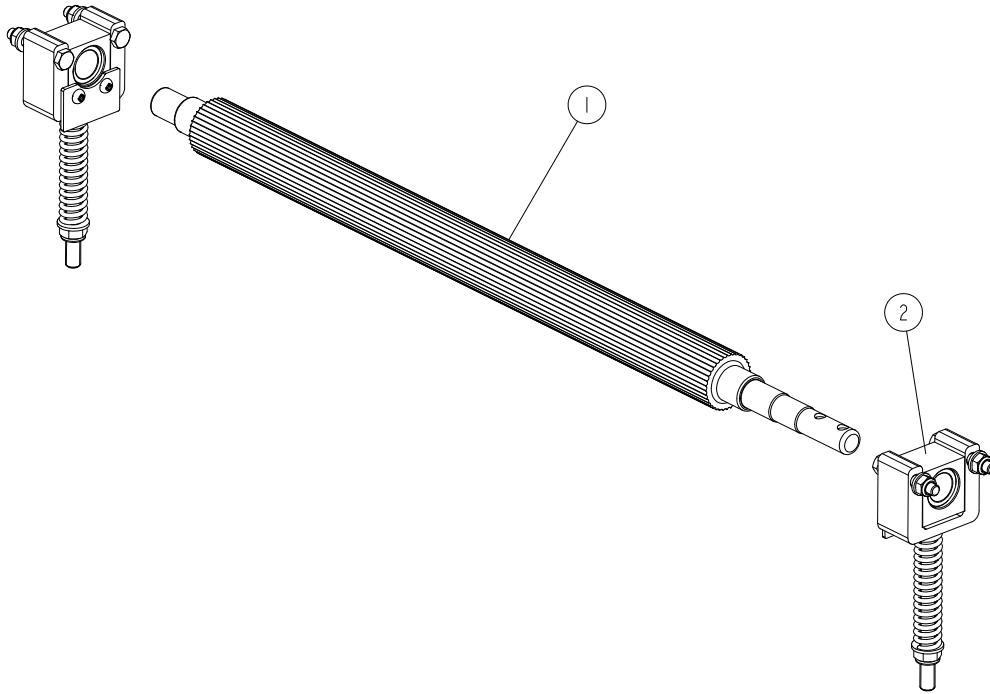

REF.	DESCRIPTION (* indicates parts available in assemblies only)	PART #	QTY	
-	SHAFT ASSEMBLY, DRIVE	533580	1	
1	SHAFT, STEEL DRIVE	533513-1	1	
2	BEARING ASSEMBLY, SLIDE See Section 2.19	533520	2	

2.19 Slide Bearing Assembly (No. 533520)

533520_001_A
533520_MANUAL

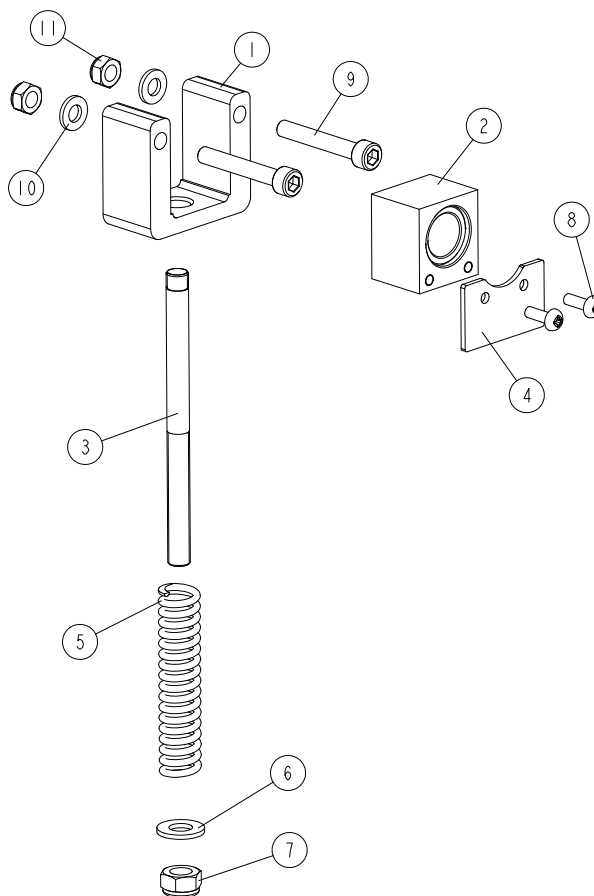

REF.	DESCRIPTION (* indicates parts available in assemblies only)	PART #	QTY
-	BEARING ASSEMBLY, SLIDE	533520	1
1	HOUSING, SLIDE BEARING	533514	1
2	BLOCK, SLIDE BEARING	537575	1
3	ROD, M8 THREADED	546898-1	1
4	COVER	533516	1
5	SPRING	533519	1
6	WASHER, 8.4 FLAT ZINC	F81054-1	1
7	NUT, M8-8-B HEX NYLON ZINC LOCK	F81032-2	1
8	SCREW, M4X12 -5,8-B CROSS RECESSED PAN HEAD ZINC	F81011-43	2
9	SCREW, M6X30-8.8 HEX SOCKET HEAD CAP ZINC	F81001-112	2
10	WASHER, 6.4 FLAT ZINC	F81053-1	2
11	NUT, M6-8-B HEX NYLON ZINC LOCK	F81031-2	2

2.20 Up/Down Assembly (No. 546738)

546738_001_A
546738_MANUAL

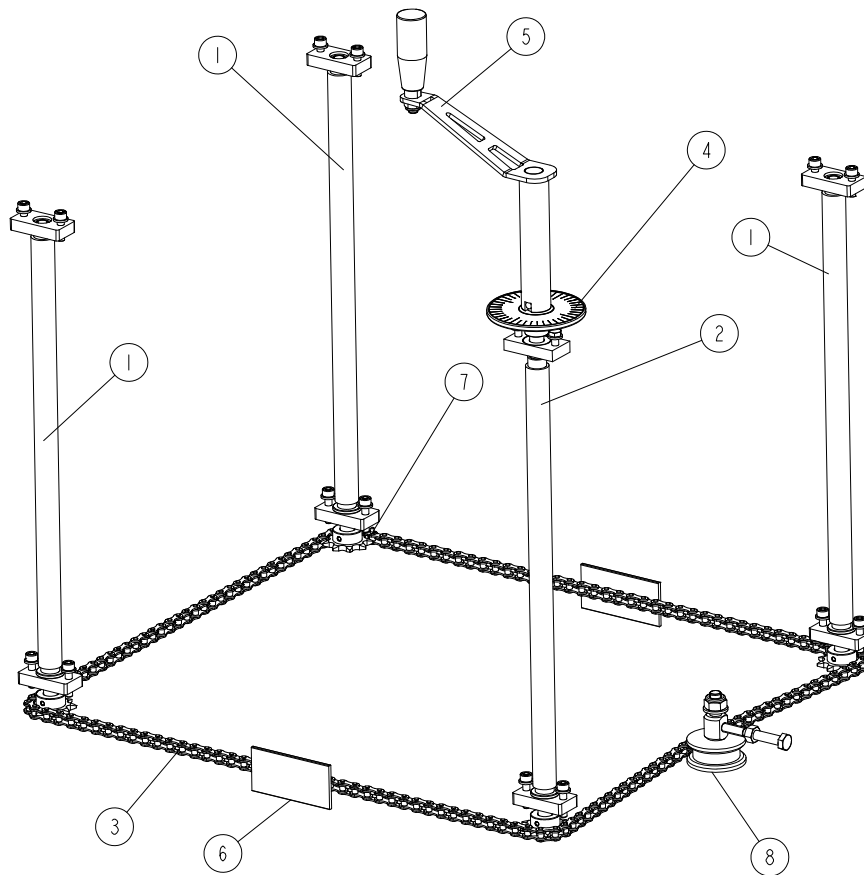

REF.	DESCRIPTION (* indicates parts available in assemblies only)	PART #	QTY
-	UP/DOWN ASSEMBLY	546738	1
1	SCREW ASSEMBLY, ACME LEAD - SHORT See Section 2.21	546716	3
2	SCREW ASSEMBLY, ACME LEAD - LONG See Section 2.22	546718	1
3	CHAIN, 083-1; P=1/2" LENGTH 2006.6 MM (158-LINK)	547241	1
4	SCALE, COMPLETE ROUND See Section 2.23	533676	1
5	HANDLE, TABLE SETTING - COMPLETE See Section 2.24	542521	1
6	TAPE, SLIDE	537562	2
7	LINK, 083-1 HALF	533129	1
8	TENSIONER, CHAIN - COMPLETE See Section 2.25	534390	1

2.21 Short Acme Screw Assembly (No. 546716)

546716_001
546716_MANUAL

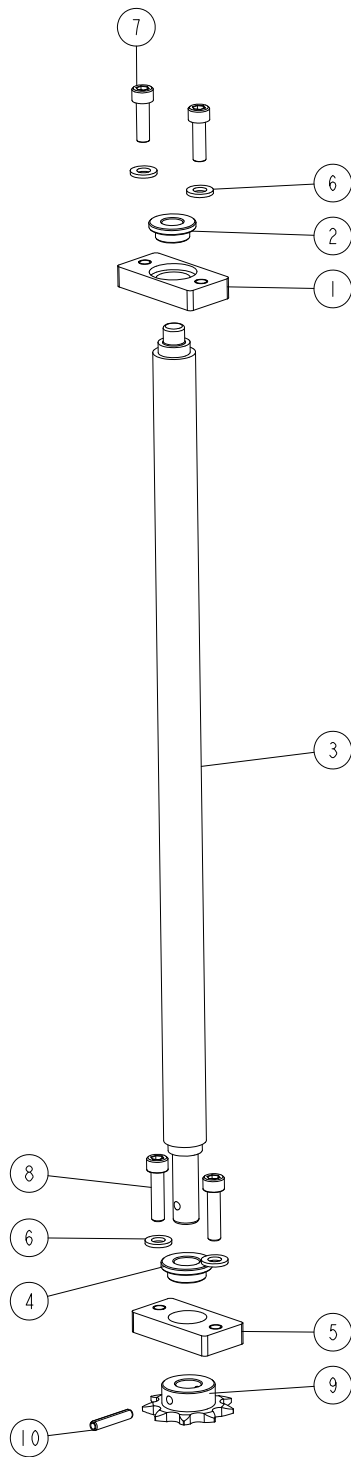

REF.	DESCRIPTION (* indicates parts available in assemblies only)	PART #	QTY	
-	SCREW ASSEMBLY, ACME LEAD - SHORT	546716	1	
1	PLATE, ACME SCREW MOUNT - UPPER	546637-1	1	
2	BUSHING, 10/16-8 FLANGED 22-3	546902	1	
3	SCREW, ACME LEAD - SHORT	546635	1	
4	BUSHING, 12/18-8 FLANGE 24-3	546901	1	

REF.	DESCRIPTION (* indicates parts available in assemblies only)	PART #	QTY	
5	PLATE, ACME SCREW MOUNT - LOWER	546636-1	1	
6	WASHER, 6.4 FLAT ZINC	F81053-1	4	
7	SCREW, M6X20 8.8 HEX SOCKET HEAD CAP ZINC	F81001-22	2	
8	SCREW, M6X25-8.8 HEX SOCKET HEAD CAP ZINC	F81001-41	2	
9	SPROCKET, Z=9; 1/2"X 3/16" (CHAIN 083-1)	533111	1	
10	PIN, 4X24 ZINC-PLATED SPRING TYPE	F81044-13	1	

2.22 Long Acme Screw Assembly (No. 546718)

546718_001_A
546718_MANUAL

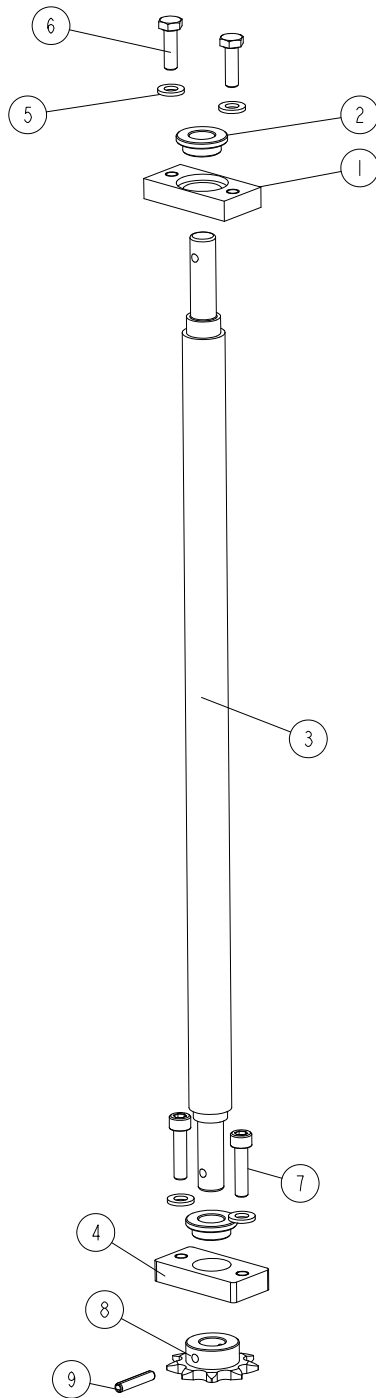

REF.	DESCRIPTION (* indicates parts available in assemblies only)	PART #	QTY	
-	SCREW ASSEMBLY, ACME LEAD - LONG	546718	1	
1	BLOCK	533113-1	1	
2	BUSHING, 12/18-8 FLANGE 24-3	546901	2	
3	SCREW, ACME LEAD - LONG	546634	1	
4	PLATE, ACME SCREW MOUNT - LOWER	546636-1	1	

REF.	DESCRIPTION (* indicates parts available in assemblies only)	PART #	QTY	
5	WASHER, 6.4 FLAT ZINC	F81053-1	4	
6	BOLT, M6X20 8.8 HEX HEAD FULL THREAD ZINC	F81001-2	2	
7	SCREW, M6X25-8.8 HEX SOCKET HEAD CAP ZINC	F81001-41	2	
8	SPROCKET, Z=9; 1/2"X 3/16" (CHAIN 083-1)	533111	1	
9	PIN, 4X24 ZINC-PLATED SPRING TYPE	F81044-13	1	

2.23 Round Scale (No. 533676)

533676_001_A
533676_MANUAL

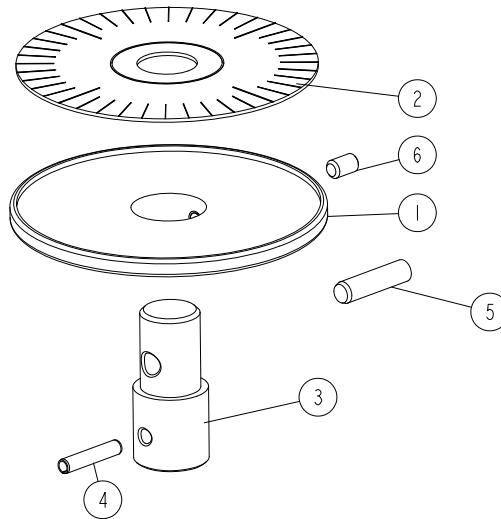

REF.	DESCRIPTION (* indicates parts available in assemblies only)	PART #	QTY
-	SCALE, COMPLETE ROUND	533676	1
1	DISK, ROUND SCALE	533594	1
2	DECAL, MP200 ROUND SCALE	533577	1
3	PIN, SCALE DISK MOUNT	533595-1	1
4	PIN, PN-EN ISO 8752-4X20-ST-A0P SPRING-TYPE	F81044-11	1
5	PIN, ISO2338- 6M6X24-A1 DOWEL	F81045-5	1
6	SCREW, M5X8 45H DIN 913 HEX SOCKET SET W/FLAT POINT	F81014-7	1

2.24 Handle Assembly (No. 542521)

542521_001
542521_MANUAL

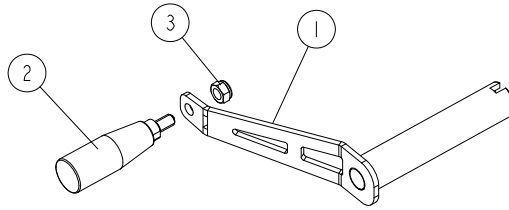

REF.	DESCRIPTION (* indicates parts available in assemblies only)	PART #	QTY	
-	HANDLE, COMPLETE	542521	1	
1	HANDLE	542522-1	1	
2	GRIP, CYLINDRICAL	533505	1	
3	NUT, M8-8-B HEX NYLON ZINC LOCK	F81032-2	1	

2.25 Chain Tensioner (No. 534390)

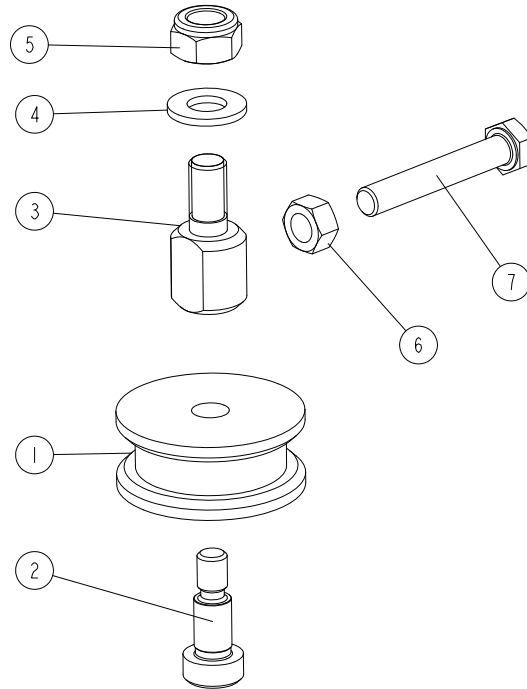
534390_001
534390_MANUAL

REF.	DESCRIPTION (* indicates parts available in assemblies only)	PART #	QTY
-	TENSIONER, CHAIN - COMPLETE	534390	1
1	ROLLER, CHAIN TENSIONER	533576	1
2	BOLT, ISO 7379-10-M8-16 12.9 SHOULDER	F81003-139	1
3	BOLT, MOUNTING	534388-1	1
4	WASHER, 10.5 FLAT ZINC	F81055-1	1
5	NUT, M10-8-B HEX NYLON ZINC LOCK	F81033-1	1
6	NUT, M8-8-B HEX ZINC	F81032-1	1
7	BOLT, M8X50 -8.8 HEX HEAD FULL THREAD ZINC	F81002-19	1

2.26 Anti-Kickback Fingers (No. 533125)

533125_001_A
533125_MANUAL

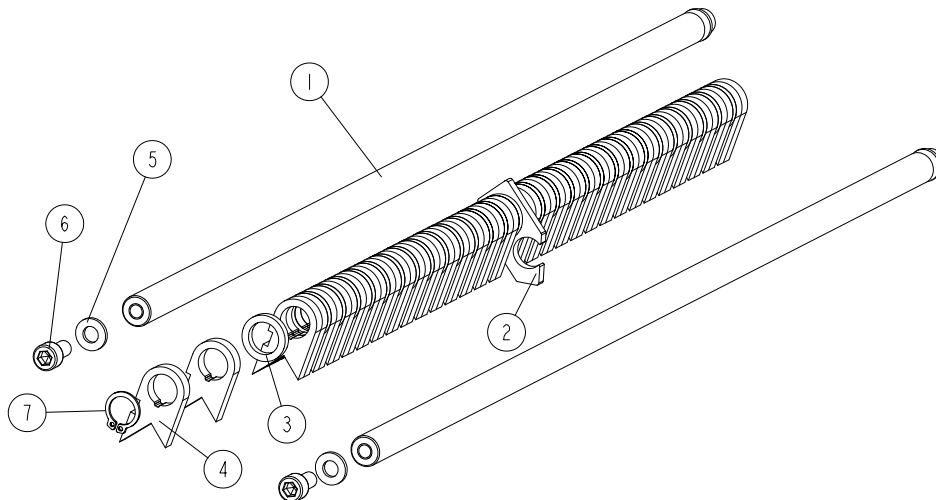

REF.	DESCRIPTION (* indicates parts available in assemblies only)	PART #	QTY
-	ANTI-KICKBACK ASSEMBLY	533125	1
1	SHAFT	533092-1	2
2	PLATE	533124-1	1
3	WASHER, DIA.1940	533123	30
4	FINGER, COMPLETE ANTI-KICKBACK	533126	30
5	WASHER, 6.4 FLAT ZINC	F81053-1	4
6	SCREW, ISO 4762-M6X12-8.8-A2E HEX SOCKET HEAD CAP	F81001-87	4
7	RING, Z12 OUTSIDE RETAINING	F81090-14	2

2.27 Cutter Assembly (No. 542485)

542485_001
542485_MANUAL

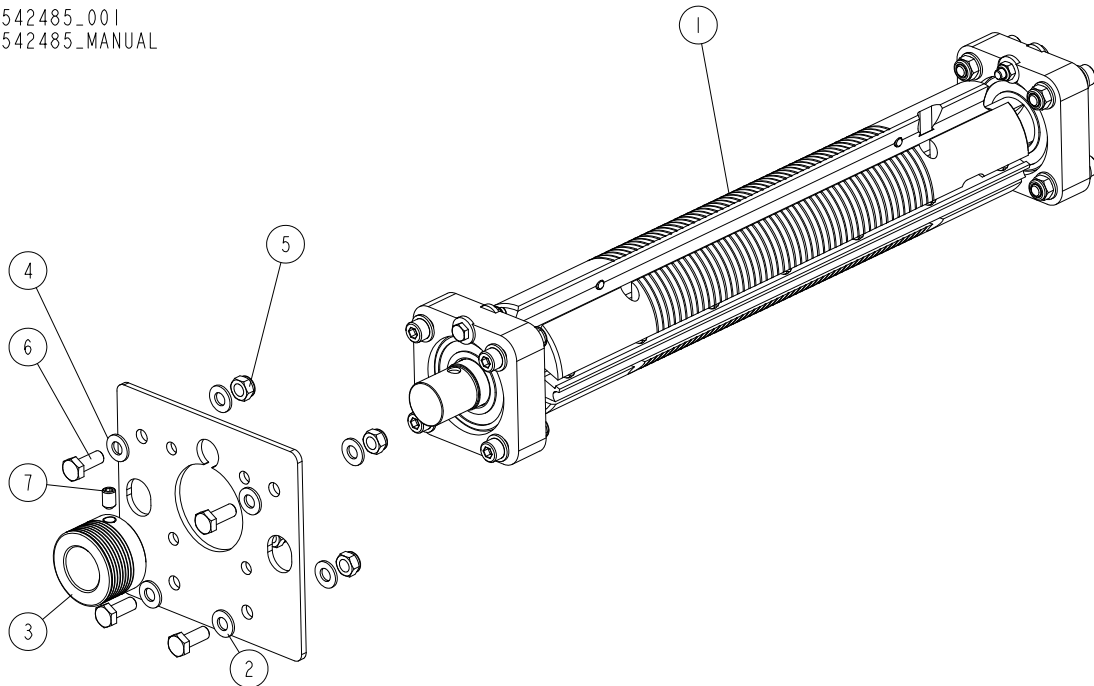

REF.	DESCRIPTION (* indicates parts available in assemblies only)	PART #	QTY
-	CUTTER ASSEMBLY	542485	1
1	CUTTER ASSEMBLY, MAIN See Section 2.28	533682	1
2	PLATE, CUTTER MOUNT	546631-1	1
3	SHEAVE, MULTI-GROOVE SMALL	533586	1
4	WASHER, 8.4 FLAT ZINC	F81054-1	8
5	NUT, M8-8-B HEX NYLON ZINC LOCK	F81032-2	4
6	BOLT, M8X20 8.8 HEX HEAD FULL THREAD ZINC	F81002-4	4
7	SCREW, M8X12-45H FE/ZN DIN914 HEX SOCKET SET W/CONE POINT	F81002-105	1

2.28 Main Cutter Assembly (No. 533682)

533682_001_B
533682_MANUAL

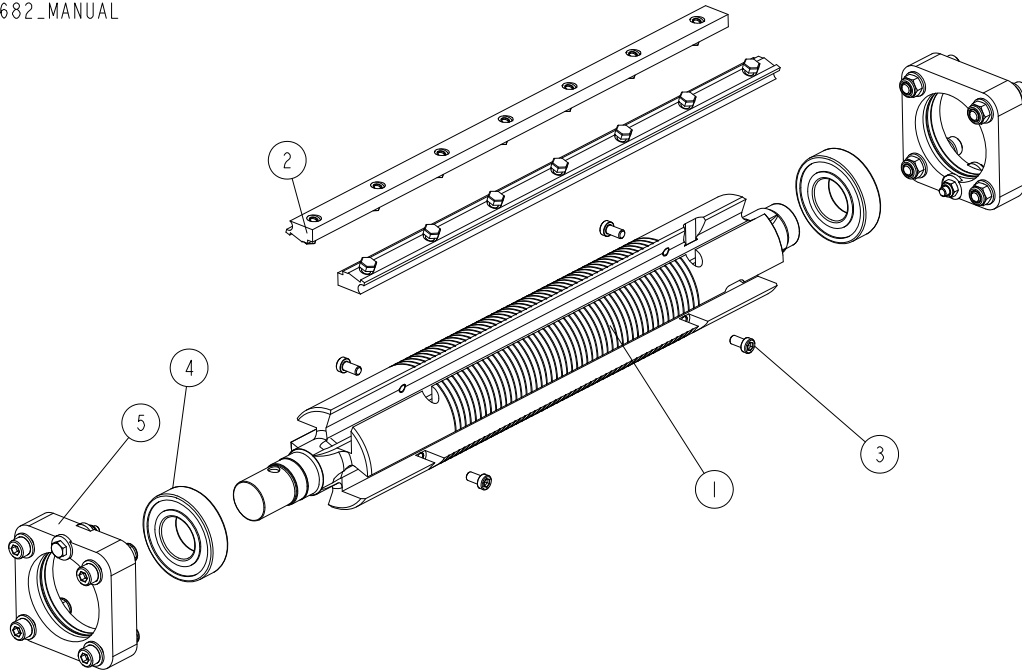

REF.	DESCRIPTION (* indicates parts available in assemblies only)	PART #	QTY
-	CUTTER ASSEMBLY, MAIN	533682	1
1	CUTTER, MAIN	260-138	1
2	WEDGE SET, MOUNTING	241-060	1
3	SCREW, M6X12-10.9 DIN 7984 HEX SOCKET THIN HEAD CAP	F81001-80	4
4	BEARING, 6206 2RSR P6 ROLLING (FAG, NSK, SKF)	100787	2
5	HOUSING ASSEMBLY, BEARING See Section 2.29	533593	2

2.29 Bearing Housing Assembly (No. 533593)

533593_001
533593_MANUAL

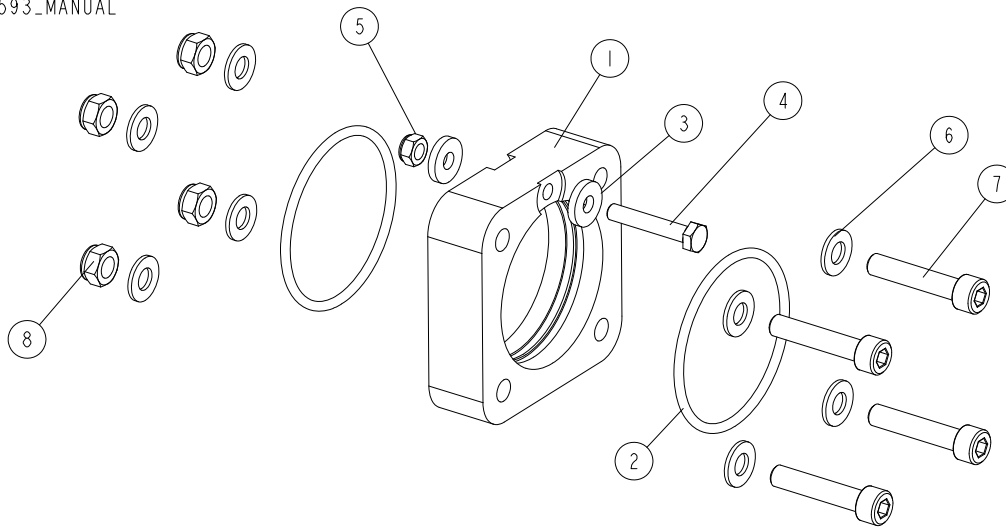

REF.	DESCRIPTION (* indicates parts available in assemblies only)	PART #	QTY
-	HOUSING ASSEMBLY, BEARING	533593	1
1	HOUSING, BEARING	533590-1	1
2	O-RING, BEARING HOUSING	533592	2
3	WASHER, 6.4 FE/ZN DIN 7349 SPACER	F81053-13	2
4	BOLT, M6X35 -8.8 HEX HEAD ZINC	F81001-71	1
5	NUT, M6-8-B HEX NYLON ZINC LOCK	F81031-2	1
6	WASHER, 8.4 FLAT ZINC	F81054-1	8
7	SCREW, M8X40-8.8 HEX SOCKET HEAD CAP ZINC	F81002-29	4
8	NUT, M8-8-B HEX NYLON ZINC LOCK	F81032-2	4

2.30 Reinforcing Bracket Assembly (No. 546724)

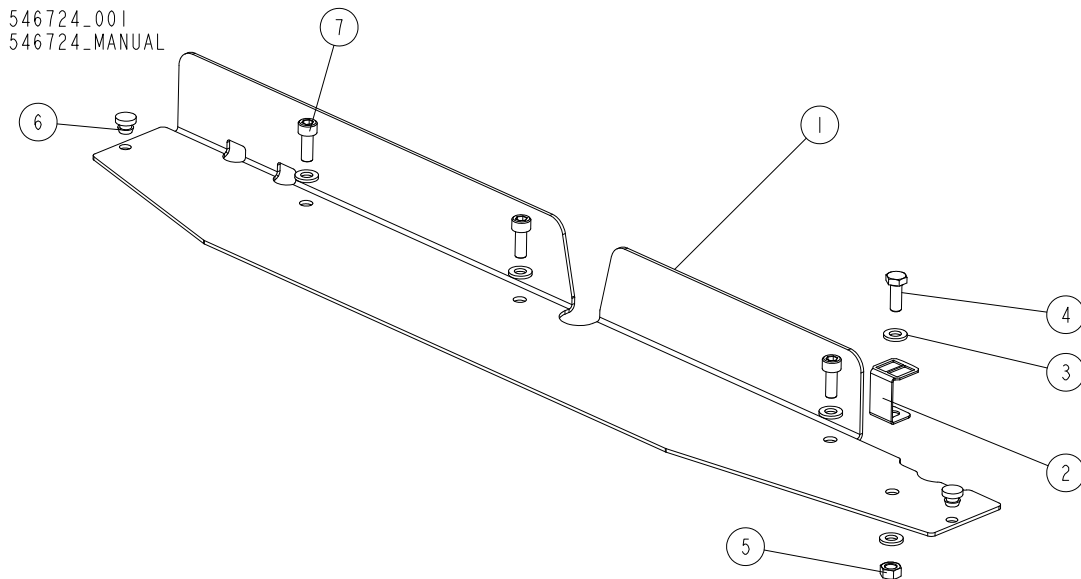

REF.	DESCRIPTION (* indicates parts available in assemblies only)	PART #	QTY
-	BRACKET ASSEMBLY, REINFORCEMENT	546724	1
1	BRACKET, REINFORCEMENT	546623-1	1
2	INDICATOR, SCALE	546624-1	1
3	WASHER, 6.4 FLAT ZINC	F81053-1	5
4	BOLT, M6X16-8.8 HEX HEAD FULL THREAD ZINC	F81001-15	1
5	NUT, M6 8 HEX ZINC	F81031-1	1
6	BUMPER, OG3 RUBBER	533568	2
7	SCREW, M6X16 8.8 HEX SOCKET HEAD CAP ZINC	F81001-21	3

2.31 Circular Blade Assembly (No. 546714)

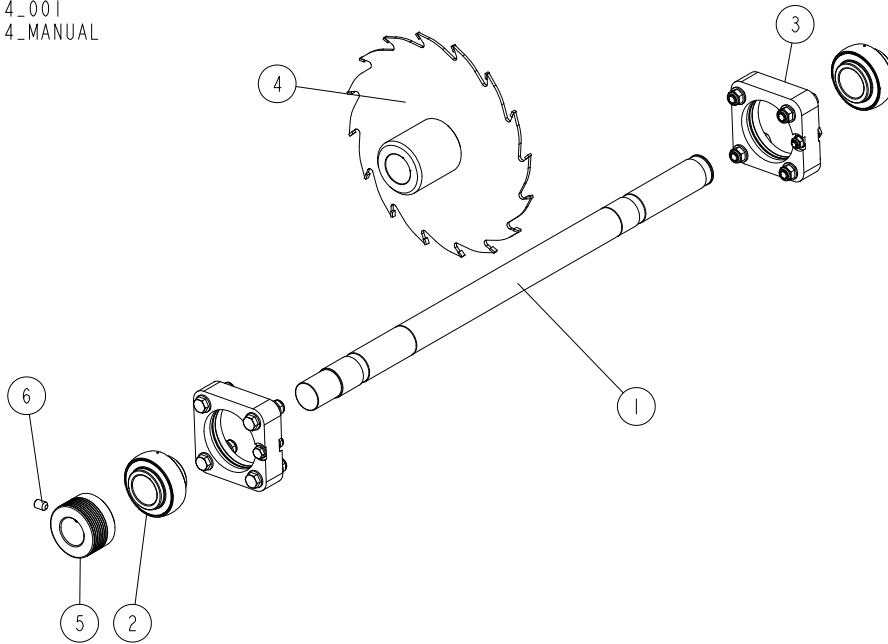
546714_001
546714_MANUAL

REF.	DESCRIPTION (* indicates parts available in assemblies only)	PART #	QTY
-	BLADE ASSEMBLY	546714	1
1	SHAFT, BLADE	546630	1
2	BEARING, UC206	542481	2
3	HOUSING ASSEMBLY, SHAFT BEARING See Section 2.32	542483	2
4	BLADE W/MOUNTING BUSHING See Section 2.33	546627	1
5	SHEAVE, MULTI-GROOVE	542482	1
6	SCREW, M8X12-45H FE/ZN DIN914 HEX SOCKET SET W/CONE POINT	F81002-105	1

2.32 Bearing Housing Assembly (No. 542483)

542483_001
542483_MANUAL

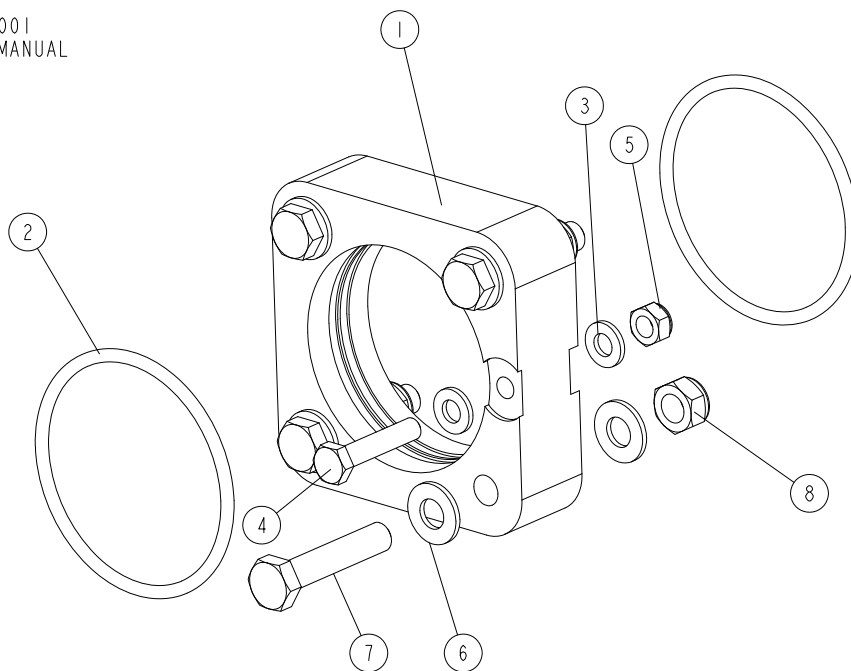

REF.	DESCRIPTION (* indicates parts available in assemblies only)	PART #	QTY
-	HOUSING ASSEMBLY, SHAFT BEARING	542483	1
1	HOUSING, BEARING	533590-1	1
2	O-RING, BEARING HOUSING	533592	2
3	WASHER, 6.4 FLAT ZINC	F81053-1	2
4	BOLT, M6X30-8.8 HEX HEAD FULL THREAD ZINC	F81001-8	1
5	NUT, M6-8-B HEX NYLON ZINC LOCK	F81031-2	1
6	WASHER, 8.4 FLAT ZINC	F81054-1	8
7	BOLT, M8X40-8.8 HEX HEAD FULL THREAD ZINC	F81002-15	4
8	NUT, M8-8-B HEX NYLON ZINC LOCK	F81032-2	4

2.33 Blade w/Mounting Bushing (No. 546627)

546627_001
546627_MANUAL

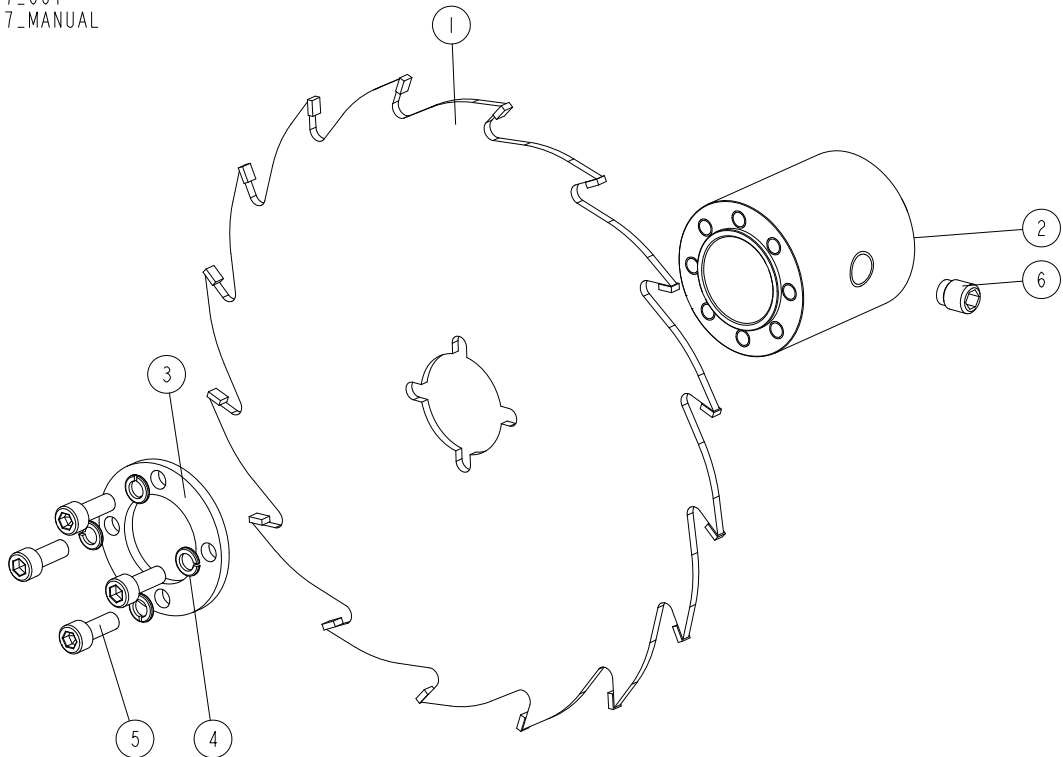

REF.	DESCRIPTION (* indicates parts available in assemblies only)	PART #	QTY
-	BLADE W/MOUNTING BUSHING	546627	1
1	BLADE, 225X3.5X2.5X35 TMB225-016-35 CIRCULAR		1
2	BUSHING , BLADE MOUNTING	546629-1	1
3	COLLAR, CLAMPING	546628-1	1
4	WASHER, Z 6.1 SPLIT LOCK ZINC	F81053-3	4
5	SCREW, M6X16 8.8 HEX SOCKET HEAD CAP ZINC	F81001-21	4
6	SCREW, M12X12 - ISO4028-45H-IS6 HEX SOCKET SET W/DOG POINT	F81004-168	1

SECTION 3 MP220 MOTORS

3.1 Electrical Kit, MP220 EH 3x400V CE Motors & Box

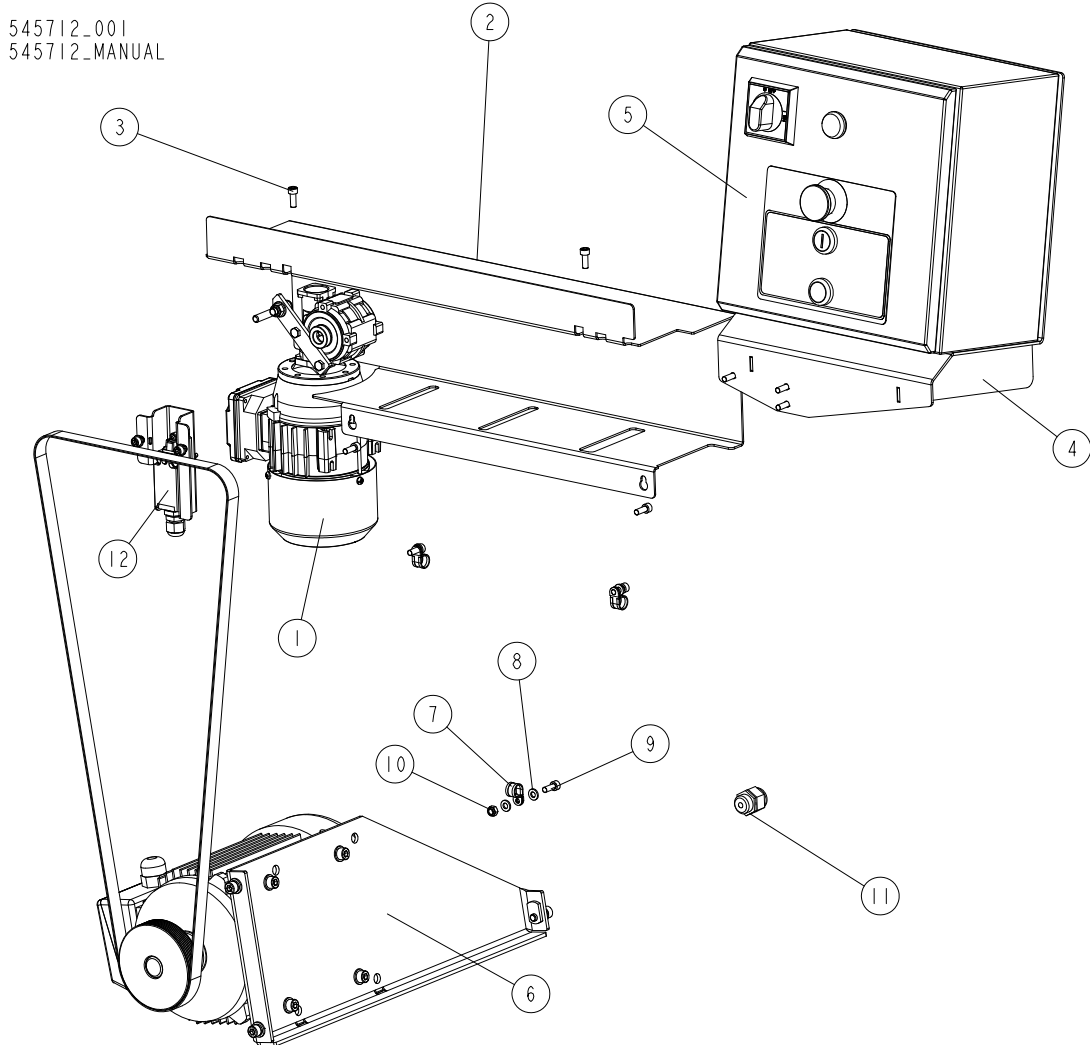

REF.	DESCRIPTION (* indicates parts available in assemblies only)	PART #	QTY
-	ELECTRICAL KIT, MP220EH 3x400V CE MOTORS & BOX	545712	1
1	DRIVE, MP200 ECO FEED See Section 3.2	533638	1
-	GUARD, CHAIN - COMPLETE	542488	1
2	GUARD, CHAIN	546622-1	1
3	SCREW, M6X16 8.8 HEX SOCKET HEAD CAP ZINC	F81001-21	4
4	BRACKET, ELECTRICAL BOX MOUNT - COMPLETE See Section 3.3	542487	1
5	BOX, MP220 ELECTRICAL - COMPLETE See Section 3.4	536949	1
6	DRIVE, CUTTER & BLADE See Section 3.5	542486	1
7	CLIP, RSGU 1.10/12W1 RETAINING	086861	3
8	WASHER, 6.4 FLAT ZINC	F81053-1	4
9	SCREW, M6X16 8.8 HEX SOCKET HEAD CAP ZINC	F81001-21	3
10	NUT, M6-8-B HEX NYLON ZINC LOCK	F81031-2	1
11	GLAND, DP 13/H CABLE	F81096-4	1

REF.	DESCRIPTION (* indicates parts available in assemblies only)	PART #	QTY	
12	SWITCH ASSEMBLY, LIMIT	546848	1	

3.2 Feed Drive (No. 533638)

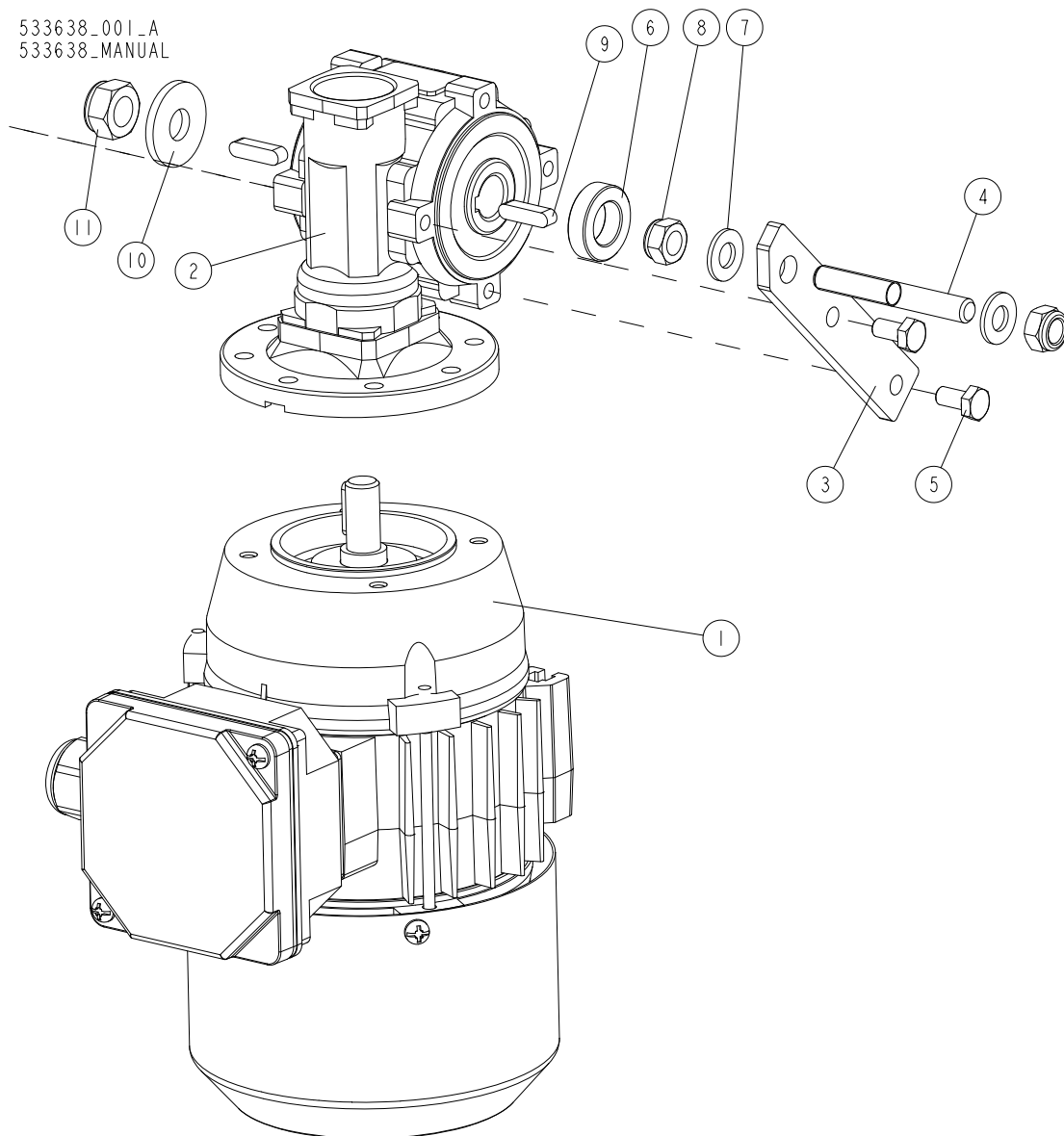

REF.	DESCRIPTION (* indicates parts available in assemblies only)	PART #	QTY
-	DRIVE, MP220 ECO FEED	533638	1
-	GEAR MOTOR, KC30/P30+SKH63-4B2/X	533639	1
1	MOTOR, SKH63-4B2 (0.18KW; 1370 R.P.M.)	532802	1
2	GEAR BOX, KC30/P30 90/11 V6	533637	1
3	ARM, TORQUE	533634-1	1
4	BOLT, M8	533635-1	1
5	BOLT, M6X12 8.8 HEX HEAD FULL THREAD ZINC	F81001-7	2
6	BUSHING, 14.3/25-7 ZINC-PLATED	533636-1	1
7	WASHER, 8.4 FLAT ZINC	F81054-1	2
8	NUT, M8-8-B HEX NYLON ZINC LOCK	F81032-2	2
9	KEY, A5X5X20 PARALLEL	513320	2
10	WASHER, 10.5 SPECIAL FLAT ZINC	F81055-6	1
11	NUT, M10-8-B HEX NYLON ZINC LOCK	F81033-1	1

3.3 Electrical Box Mount Bracket (No. 542487)

542487_001
542487_MANUAL

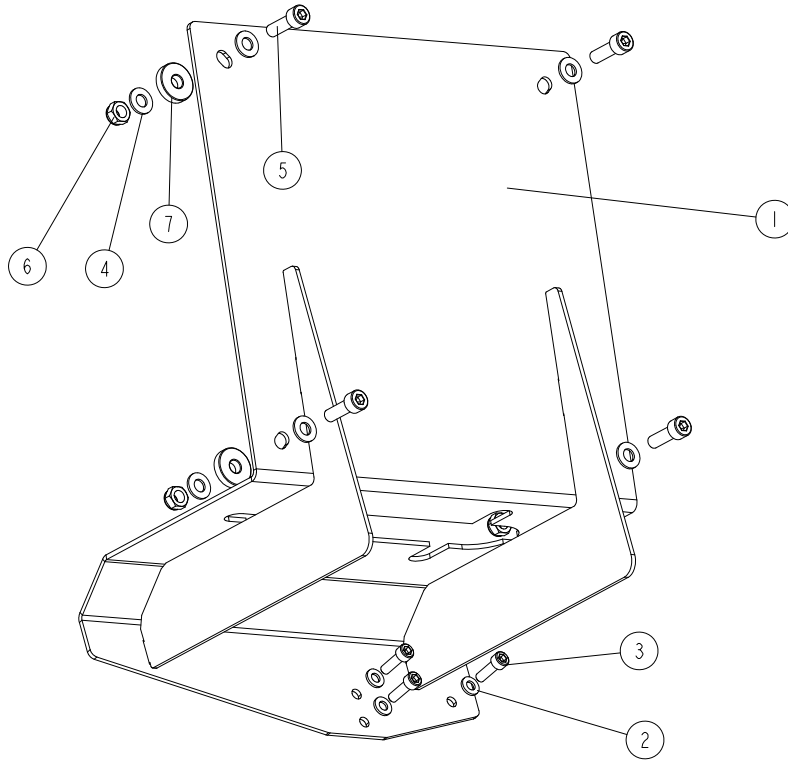

REF.	DESCRIPTION (* indicates parts available in assemblies only)	PART #	QTY
-	BRACKET, ELECTRICAL BOX MOUNT - COMPLETE	542487	1
1	BRACKET ASSEMBLY, ELECTRICAL BOX MOUNT	546248-1	1
2	WASHER, 6.4 FLAT ZINC	F81053-1	3
3	SCREW, M6X20 8.8 HEX SOCKET HEAD CAP ZINC	F81001-22	3
4	WASHER, 8.4 FLAT ZINC	F81054-1	8
5	SCREW, M8X25 -8.8 HEX SOCKET HEAD CAP ZINC	F81002-21	4
6	NUT, M8-8-B HEX NYLON ZINC LOCK	F81032-2	4
7	WASHER, 8.5/25-6 POLYAMIDE	523952	4

3.4 Electrical Box (No. 536949)

536949_001
536949_MANUAL

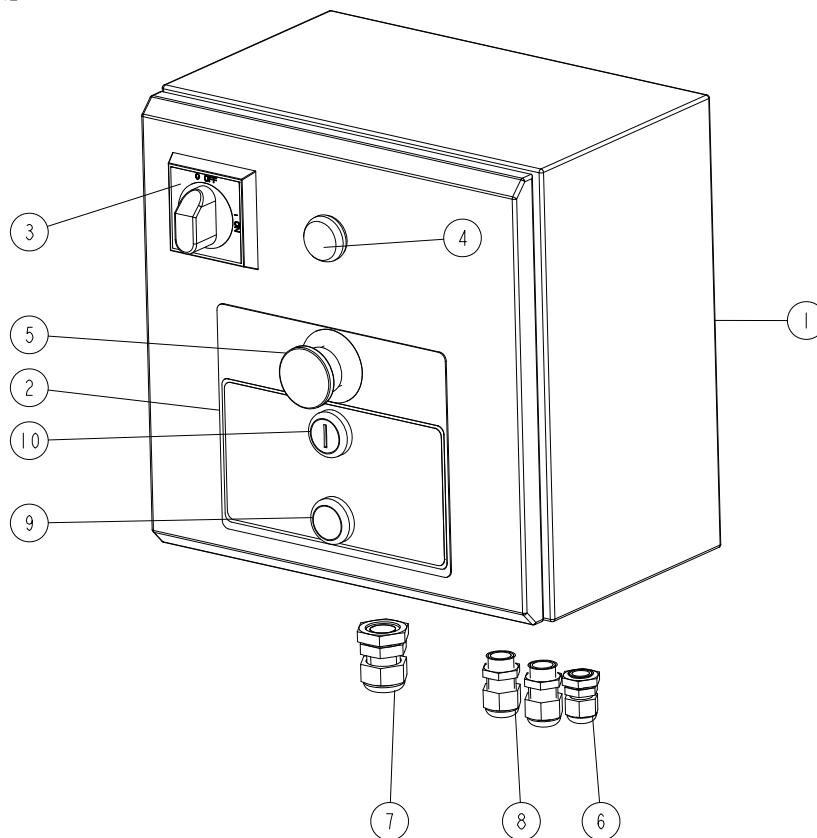

REF.	DESCRIPTION (* indicates parts available in assemblies only)	PART #	QTY
-	BOX, MP220 ELECTRICAL - COMPLETE	536949	1
1	BOX, ELECTRICAL	534763	1
2	DECAL, ELECTRICAL BOX	534765	1
3	HANDLE, ABB SWITCH	088265-1	1
4	LIGHT, M22 LED 24V BLUE CONTROL	090448	1
5	SWITCH, XB4 BS542 EMERGENCY STOP	086556	1
6	GLAND, DP9/H CABLE	F81096-2	1
7	GLAND, DP16/H CABLE	F81096-7	1
8	GLAND, DW11/H CABLE	085388	2
9	BUTTON, LPCB2102 - COMPLETE	535437-K	1
10	BUTTON, LPCBL1117 - COMPLETE	535441-K	1

3.5 Cutter & Blade Drive Assembly (No. 542486)

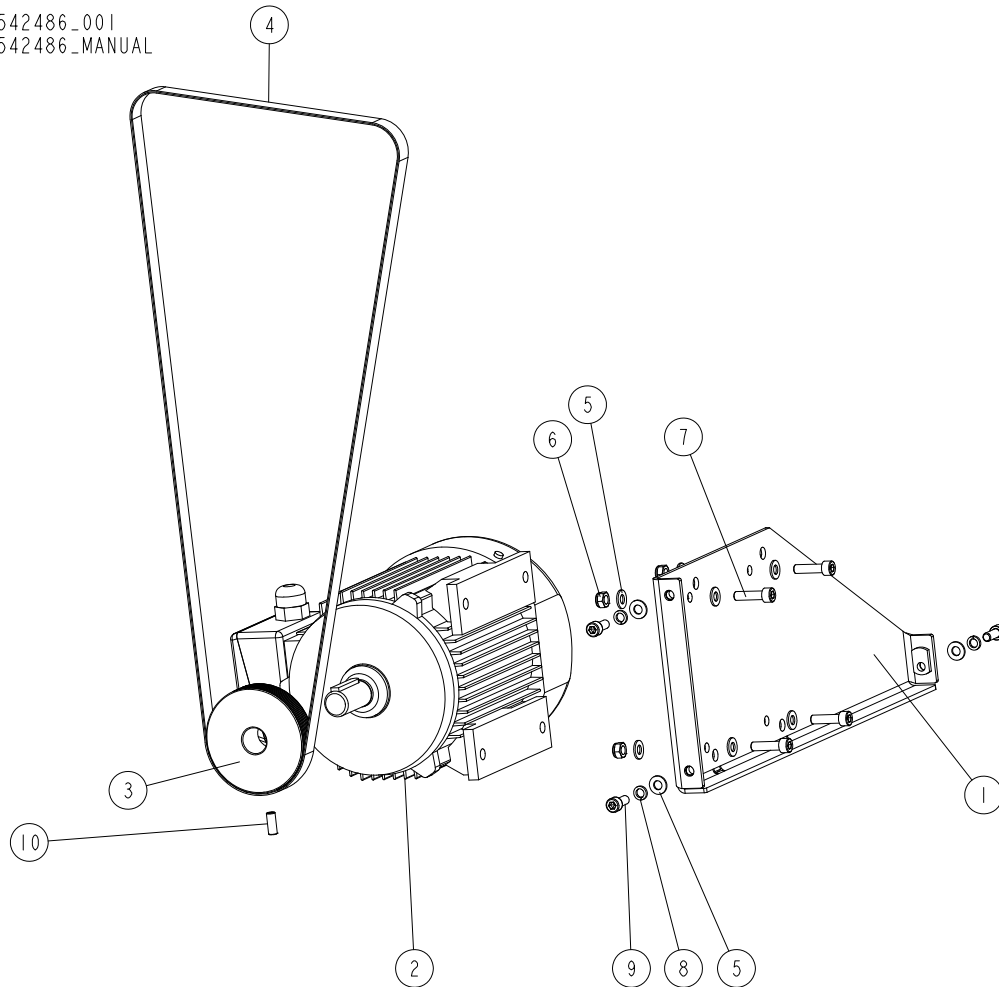
542486_001
542486_MANUAL

REF.	DESCRIPTION (* indicates parts available in assemblies only)	PART #	QTY
-	DRIVE ASSEMBLY, CUTTER & BLADE	542486	1
1	PLATE WELDMENT, MOTOR MOUNT	542490-1	1
2	MOTOR, NIDEC 3KW 2P M90XL IMB3 (3KW; 2860 R.P.M.)	533644	1
3	SHEAVE, MULTI-GROOVE	533585	1
4	BELT, 8 PJ 1600 RIBBED	546621	1
5	WASHER, 8.4 FLAT ZINC	F81054-1	11
6	NUT, M8-8-B HEX NYLON ZINC LOCK	F81032-2	4
7	SCREW, M8X30 8.8 HEX SOCKET HEAD CAP ZINC	F81002-31	4
8	WASHER, 8.2 SPLIT LOCK ZINC	F81054-4	3
9	SCREW, M8X20-8.8 HEX SOCKET HEAD CAP ZINC	F81002-30	3
10	SCREW, M8X20-45H DIN913 GEOMET HEX SOCKET SET W/FLAT POINT	F81002-103	1