

Wood-Mizer®

Parts Manual

MP220

rev. A1.08



Safety is our #1 concern! Read and understand all safety information and instructions before operating, setting up or maintaining this machine.

Form #2466

Table of Contents

Section-Page

SECTION 1	GENERAL INFORMATION	1-1
1.1	How To Use the Parts List.....	1-1
1.2	Sample Assembly	1-1
SECTION 2	MP220 MOULDER/PLANER/RIPSAW	2-1
2.1	MP220	2-1
2.2	Guards & Shafts	2-2
2.3	Knives	2-3
2.4	Decals	2-4
2.5	Additional Parts Kit (No. 542491)	2-6
2.6	Wrench Set (No. 535185)	2-7
2.7	Foot Set (No. 536996)	2-8
2.8	Right Guard (No. 546786)	2-9
2.9	Left Guard (No. 546784)	2-10
2.10	Flexible Guard (No. 533729)	2-11
2.11	Top Cover (No. 546613)	2-12
2.12	Knob Assembly (No. 546845)	2-13
2.13	Cast-Iron Table (No. 546737)	2-14
2.14	Press Roller Assembly (No. 533100)	2-15
2.15	Guide Bar Assembly (No. 546715)	2-17
2.16	Feed Assembly (No. 546795)	2-19
2.17	Shaft w/Protective Cover (No. 533581)	2-20
2.18	Drive Shaft Assembly (No. 533580)	2-21
2.19	Slide Bearing Assembly (No. 533520)	2-22
2.20	Up/Down Assembly (No. 546738)	2-23
2.21	Short Acme Screw Assembly (No. 546716)	2-24
2.22	Long Acme Screw Assembly (No. 546718)	2-26
2.23	Round Scale (No. 533676)	2-28
2.24	Handle Assembly (No. 542521)	2-29
2.25	Chain Tensioner (No. 534390)	2-30
2.26	Anti-Kickback Fingers (No. 533125)	2-31
2.27	Cutter Assembly (No. 542485)	2-32
2.28	Main Shaft Assembly (533682)	2-34
2.29	Helical Top Cutter Assembly THH220TC-S (Option)	2-35
2.30	Bearing Housing Assembly (No. 533593)	2-36
2.31	Reinforcing Bracket Assembly (No. 546724)	2-37
2.32	Circular Blade Assembly (No. 546714)	2-38
2.33	Bearing Housing Assembly (No. 542483)	2-39
2.34	Blade w/Mounting Bushing (No. 546627)	2-40
2.35	Outfeed Table Extension (No. 546935)	2-41
2.36	Material Guide Assembly (option)	2-42
2.37	Table Infeed-Outfeed (546940)	2-43
2.38	Table 546819	2-44

Table of Contents

Section-Page

2.39	Side Clamp, MP200/MP220 (No. 564986) - additional equipment	2-46
------	---	------

SECTION 3 MOTOR KITS MP220 CE 3-1

3.1	Motor Kits 545712	3-1
3.2	ECO Feed Drive 533638	3-3
3.3	Motoreducer 533639	3-4
3.4	ECO Feed Drive 533638-6	3-5
3.5	Motoreducer 533654	3-6
3.6	PRO Feed Drive 533650	3-7
3.7	Reducer 533640	3-8
3.8	Chain Guard 542488	3-9
3.9	Electrical Box Mount Bracket 542487	3-10
3.10	Electrical Box 536949	3-11
3.11	Cutter & Blade Drive Assembly 542486	3-12
3.12	Cutter & Blade Drive Assembly 542486-6	3-13
3.13	Limit Switch Assembly 546848	3-14

SECTION 4 MOTOR KITS MP220 UL AMERICAN VERSION 4-1

4.1	Motor Kit 545722-2U	4-1
4.2	Motor Kit 545722-6U	4-2
4.3	PRO Feed Drive 533650-U	4-3
4.4	Motoreducer 533640-UL	4-4
4.5	PRO Feed Drive 533650-6U	4-5
4.6	Up/Down Drive 597559	4-6
4.7	Cutter & Blade Drive Assembly 546900-2U	4-7
4.8	Cutter & Blade Drive Assembly 546900-6U	4-8

SECTION 1 GENERAL INFORMATION

1.1 How To Use the Parts List

- Use the index above to locate the assembly that contains the part you need.
- Go to the appropriate section and locate the part in the illustration.
- Use the number pointing to the part to locate the correct part number and description in the table.
- Parts shown indented under another part are included with that part.
- Parts marked with a diamond (◆) are only available in the assembly listed above the part.

See the sample table below. Sample Part #A01111 includes part F02222-2 and subassembly A03333. Subassembly A03333 includes part S04444-4 and subassembly K05555. The diamond (◆) indicates that S04444-4 is not available except in subassembly A03333. Subassembly K05555 includes parts M06666 and F07777-77. The diamond (◆) indicates M06666 is not available except in subassembly K05555.

1.2 Sample Assembly				
REF.	DESCRIPTION (◆ Indicates Parts Available In Assemblies Only)	PART #	QTY	
	Sample Assembly, Complete (Includes All Indented Parts Below)	A01111	1	
1	Sample Part	F02222-22	1	
	Sample Subassembly (Includes All Indented Parts Below)	A03333	1	
2	Sample Part (◆ Indicates Part Is Only Available With A03333)	S04444-4	1	◆
	Sample Subassembly (Includes All Indented Parts Below)	K05555	1	
3	Sample Part (◆ Indicates Part Is Only Available With K05555)	M06666	2	◆
4	Sample Part	F07777-77	1	

To Order Parts:

- From Europe call our European Headquarters and Manufacturing Facility in Kolo, Poland at **+48-63-2626000**. From the continental U.S., call our toll-free Parts hotline at **1-800-525-8100**. Have your customer number, vehicle identification number, and part numbers ready when you call. From other international locations, contact the Wood-Mizer distributor in your area for parts.

Office Hours:

Country	Monday - Friday	Saturday	Sunday
Poland	7-15	Closed	Closed
US	8 a.m.- 5 p.m.	8 a.m.- 12 p.m.	Closed



CAUTION! It is strongly recommended that only original spare parts be used.

SECTION 2 MP220 MOULDER/PLANER/RIPSAW

2.1 MP220

MP220EH3S_001
MP220EH3S_MANUAL

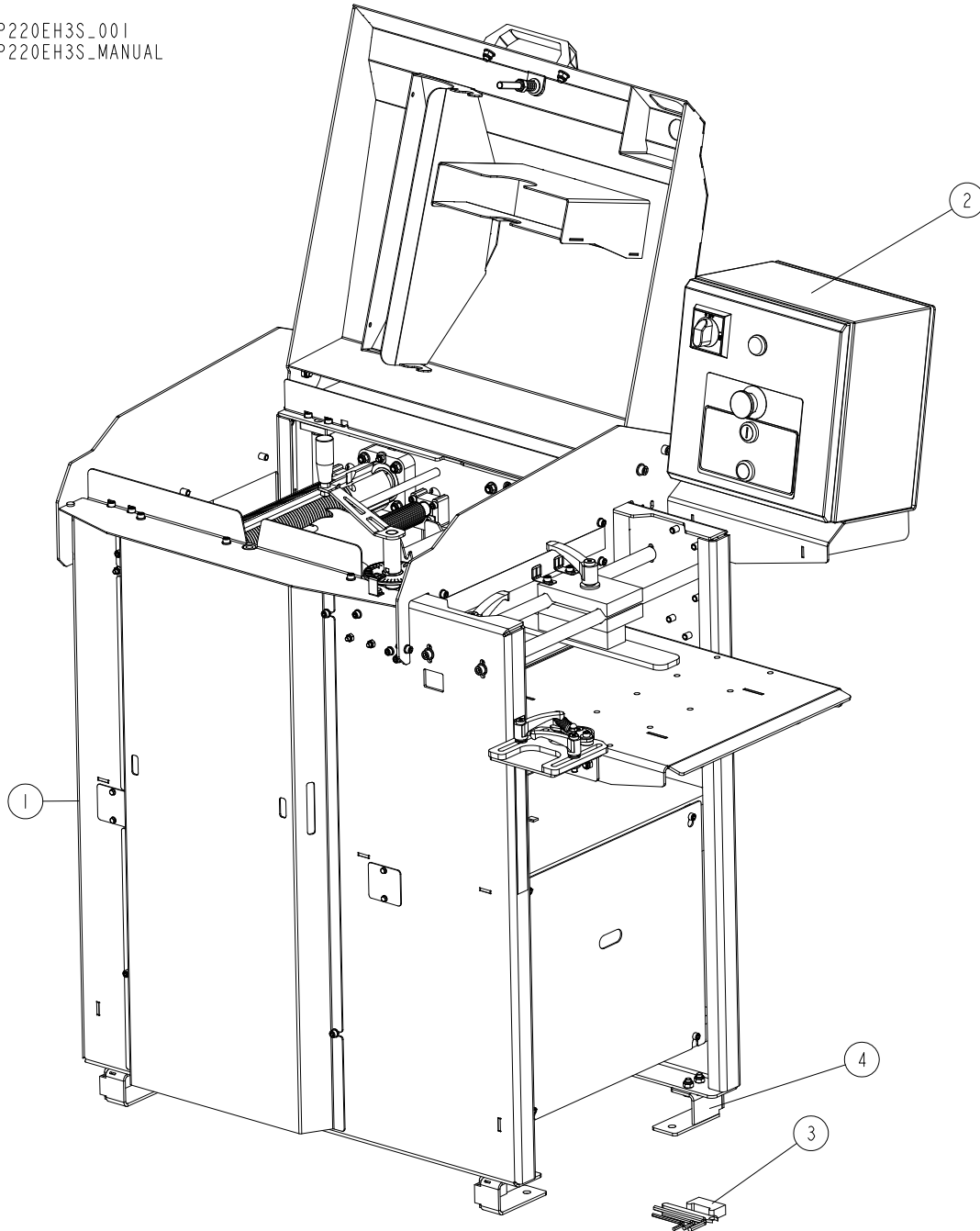

REF.	DESCRIPTION (* indicates parts available in assemblies only)	PART #	QTY
-	MOULDER/PLANER/RIPSAW, MP220EH3S		1
1	MP220 - MECHANICAL ASSEMBLY	542500	1
2	ELECTRICAL KIT, MP220EH 3X400V CE MOTORS & BOX See Section 3.1	545712	1
3	PARTS KIT, MP220 ADDITIONAL See Section 2.5	542491	1
4	FOOT SET See Section 2.7	536996	1

2.2 Guards & Shafts

542500-002
542500-MANUAL

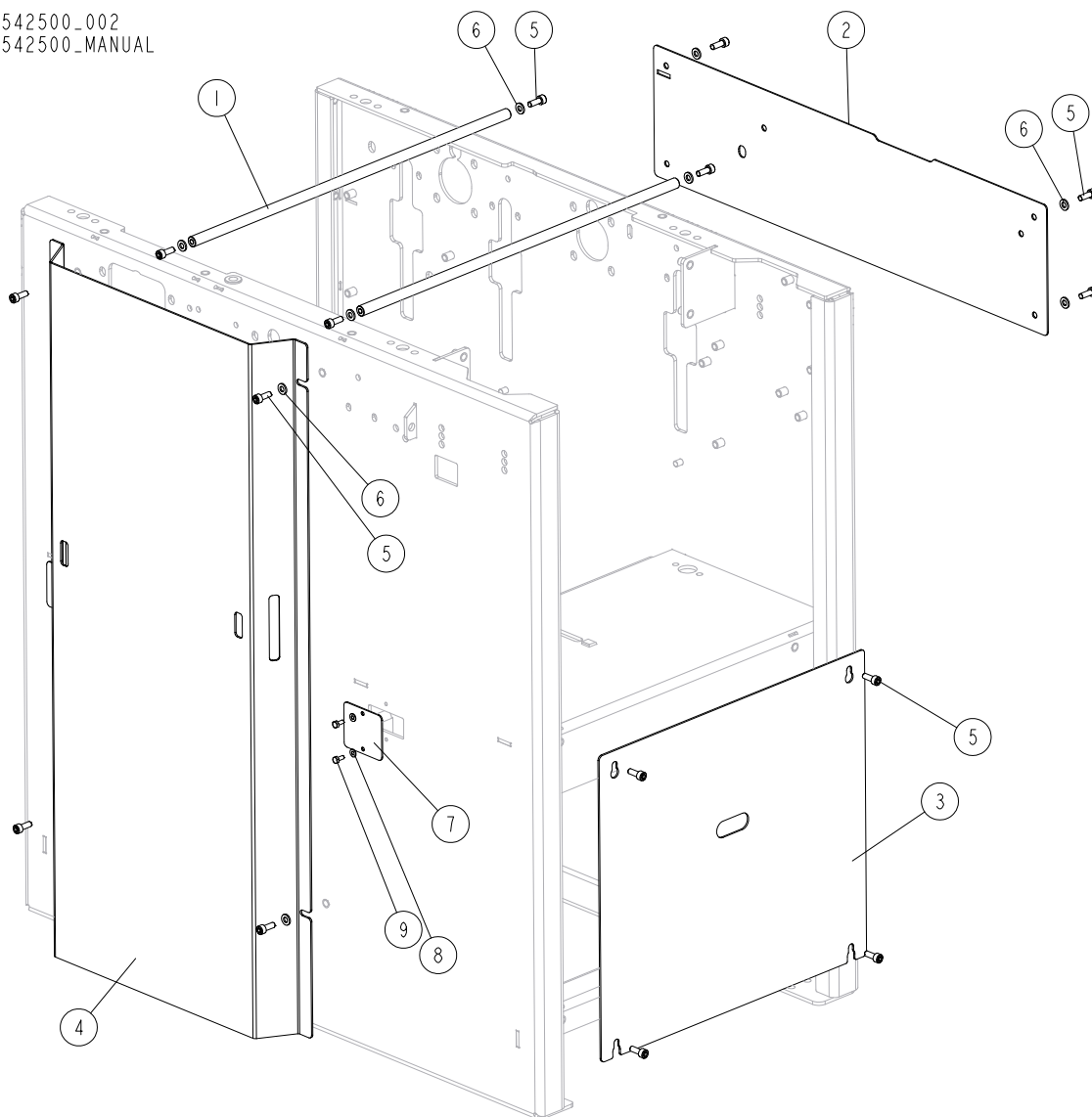

REF.	DESCRIPTION (* indicates parts available in assemblies only)	PART #	QTY
1	SHAFT	533092-1	2
2	PLATE, COVER	546626-1	1
3	COVER I	546648-1	2
4	GUARD, BELT	546625-1	1
5	SCREW, M6X16 8.8 HEX SOCKET HEAD CAP ZINC	F81001-21	20
6	WASHER, 6.4 FLAT ZINC	F81053-1	10
7	COVER, INSPECTION WINDOW	536995-1	4
8	WASHER, 4.3 FLAT ZINC	F81051-2	8
9	BOLT, M4X10 DIN 933/ISO 4017 (A2) STAINLESS STEEL	F81000-27	8

2.3 Knives

542500_003
542500_MANUAL

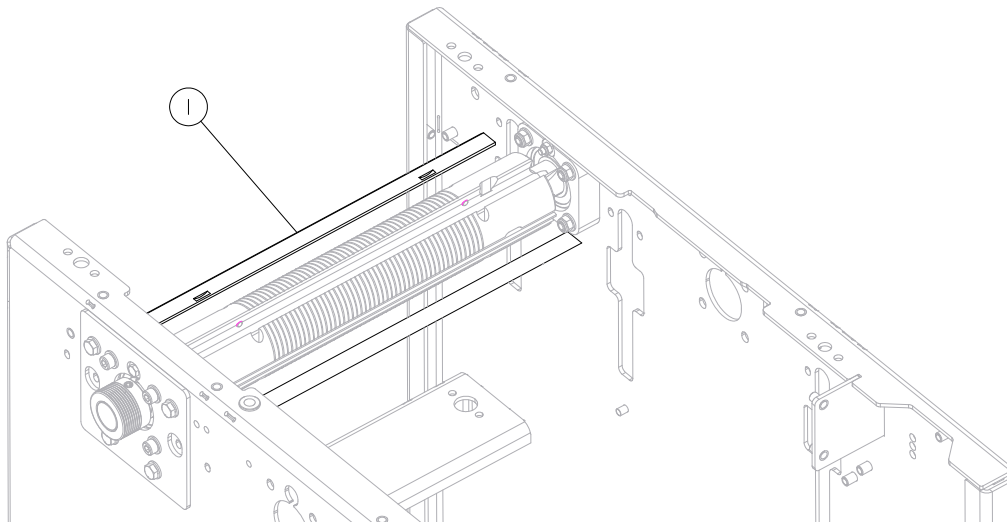

REF.	DESCRIPTION (* indicates parts available in assemblies only)	PART #	QTY
-	PLANER KNIFE WITH NOTCHES	TPK410.20MP	2
1	TPK410.20HS	TPK41020HS	2

2.4 Decals

MP220EH3S_002
MP220EH3S_MANUAL

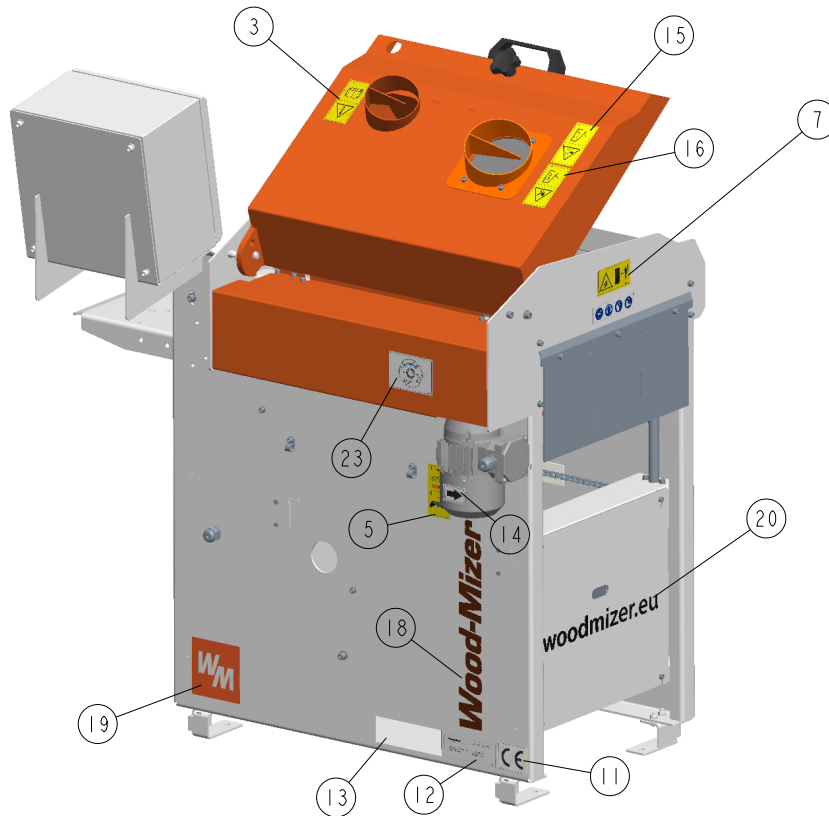
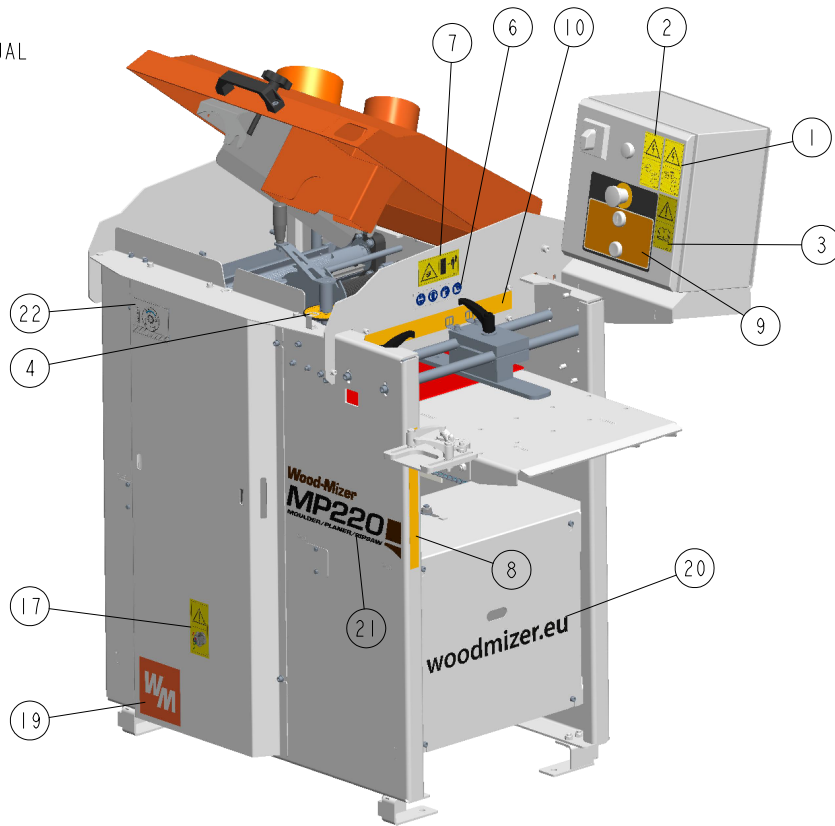

REF.	DESCRIPTION (* indicates parts available in assemblies only)	PART #	QTY
-	DECAL KIT, MP220	553362	1
1	DECAL, REMOVE THE PLUG BEFORE OPENING THE ELECTRICAL BOX (PICTOGRAM)	096319	1
2	DECAL, HAZARDOUS VOLTAGE INSIDE THE ELECTRICAL BOX (PICTOGRAM)	096316	1
3	DECAL, "READ THE OPERATOR'S MANUAL"	096317	2
4	DECAL, MP200 ROUND SCALE	533577	1
5	DECAL, "USE THE CONTINUOUSLY VARIABLE TRANSMISSION WHEN THE FEED IS TURNED ON" (PICTOGRAM)	535252	1
6	DECAL - WARNING PICTOGRAMS	535402	2
7	DECAL, "KEEP A SAFE DISTANCE" PICTOGRAM	099221H	2
8	SCALE, MP220 TABLE HEIGHT	546600	1
9	DECAL, ELECTRICAL BOX	534765	1
10	SCALE, MP220 CUTTING WIDTH	546599	1
11	DECAL, CE CERTIFIED SAWMILL - SMALL	P85070	1
12	DECAL, EUROPEAN HEADQUARTER ADDRESS	015841	1
13	DECAL, VIN	VIN	1
14	DECAL, MOTOR REVOLUTIONS DIRECTION	S20097	1
15	DECAL, "CLOSE GUARDS AND COVERS BEFORE OPERATING"	099220	1
16	DECAL, HAND INJURY HAZARD (PICTOGRAM)	524993	1
17	DECAL, CORRECT MOTOR REVOLUTIONS DIRECTION (PICTOGRAM)	553360	1
18	DECAL, "WOOD-MIZER"	553366	1
19	DECAL, "WM"	553364	2
20	DECAL, "WOODMIZER.EU"	553365	2
21	DECAL, MP220 MACHINE TYPE	553361	1
22	DECAL, MP200 MAXIMUM PLANING THICKNESS	535155	1
23	DECAL, MP160 SHAFT ROTATION DIRECTION	536401	1

2.5 Additional Parts Kit (No. 542491)

542491_001
542491_MANUAL

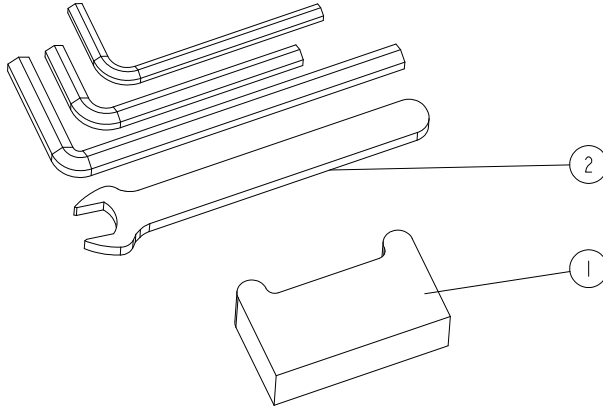

REF.	DESCRIPTION (* indicates parts available in assemblies only)	PART #	QTY	
-	PARTS KIT, MP220 ADDITIONAL	542491	1	
1	TOOL, KNIFE SETTING	534770	1	
2	WRENCH SET, MP160 See Section 2.6	535185	1	

2.6 Wrench Set (No. 535185)

535185_001
535185_MANUAL

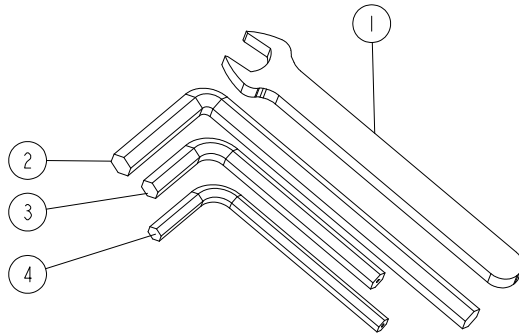

REF.	DESCRIPTION (* indicates parts available in assemblies only)	PART #	QTY
-	WRENCH SET, MP160	535185	1
1	WRENCH, 10 OPEN-END	541315	1
2	WRENCH, 6 MM ALLEN	535186	1
3	WRENCH, 5 ALLEN	092915	1
4	WRENCH, 4MM ALLEN	093368	1

2.7 Foot Set (No. 536996)

536996_001_A
536996

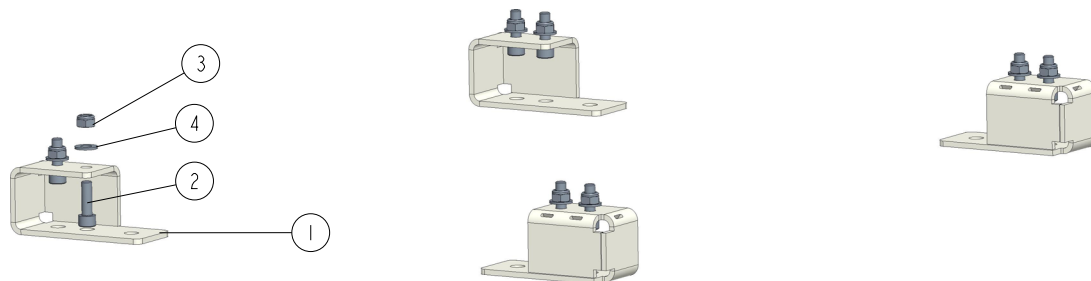

REF	DESCRIPTION (◆ indicates parts available in assemblies only)	PART #	QTY
-	FOOT SET	536996	1
1	FOOT	535828-1	4
2	SCREW, M8X25 -8.8 HEX SOCKET HEAD CAP	F81002-21	8
3	NUT, M8-8-B HEX NYLON ZINC LOCK	F81032-2	8
4	WASHER, 8.4 FLAT ZINC	F81054-1	16

2.8 Right Guard (No. 546786)

546786_001
546786_MANUAL

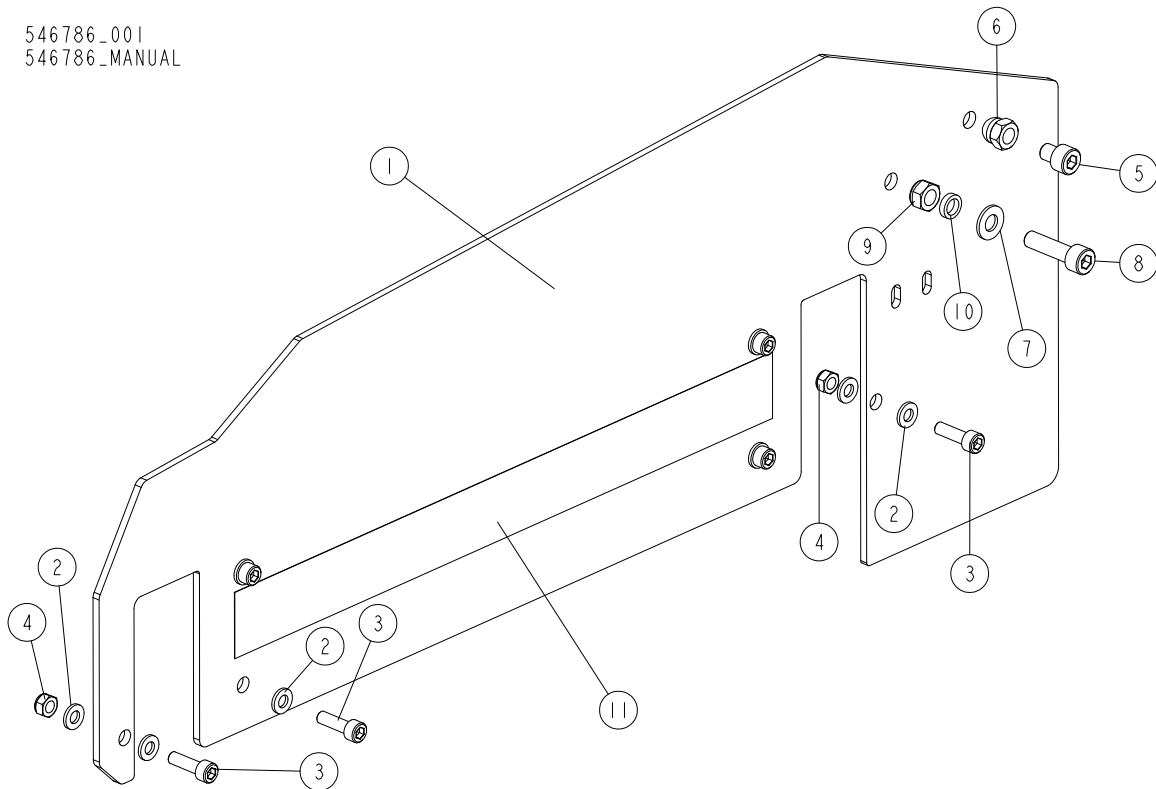

REF.	DESCRIPTION (* indicates parts available in assemblies only)	PART #	QTY
-	GUARD, COMPLETE RIGHT	546786	1
1	PLATE, RIGHT GUARD	546616-1	1
2	WASHER, 6.4 FLAT ZINC	F81053-1	8
3	SCREW, M6X20 8.8 HEX SOCKET HEAD CAP ZINC	F81001-22	6
4	NUT, M6-8-B HEX NYLON ZINC LOCK	F81031-2	2
5	SCREW, M8X10-8.8 HEX SOCKET HEAD CAP ZINC	F81002-32	1
6	NUT, M8 ZINC DOMED CAP	F81033-25	1
7	WASHER, 8.4 FLAT ZINC	F81054-1	1
8	SCREW, M8X30 8.8 HEX SOCKET HEAD CAP ZINC	F81002-31	1
9	NUT, M8-8-B HEX NYLON ZINC LOCK	F81032-2	1
10	BUSHING, SPACER	533674	1
11	SCALE, MP220 CUTTING WIDTH	546599	1

2.9 Left Guard (No. 546784)

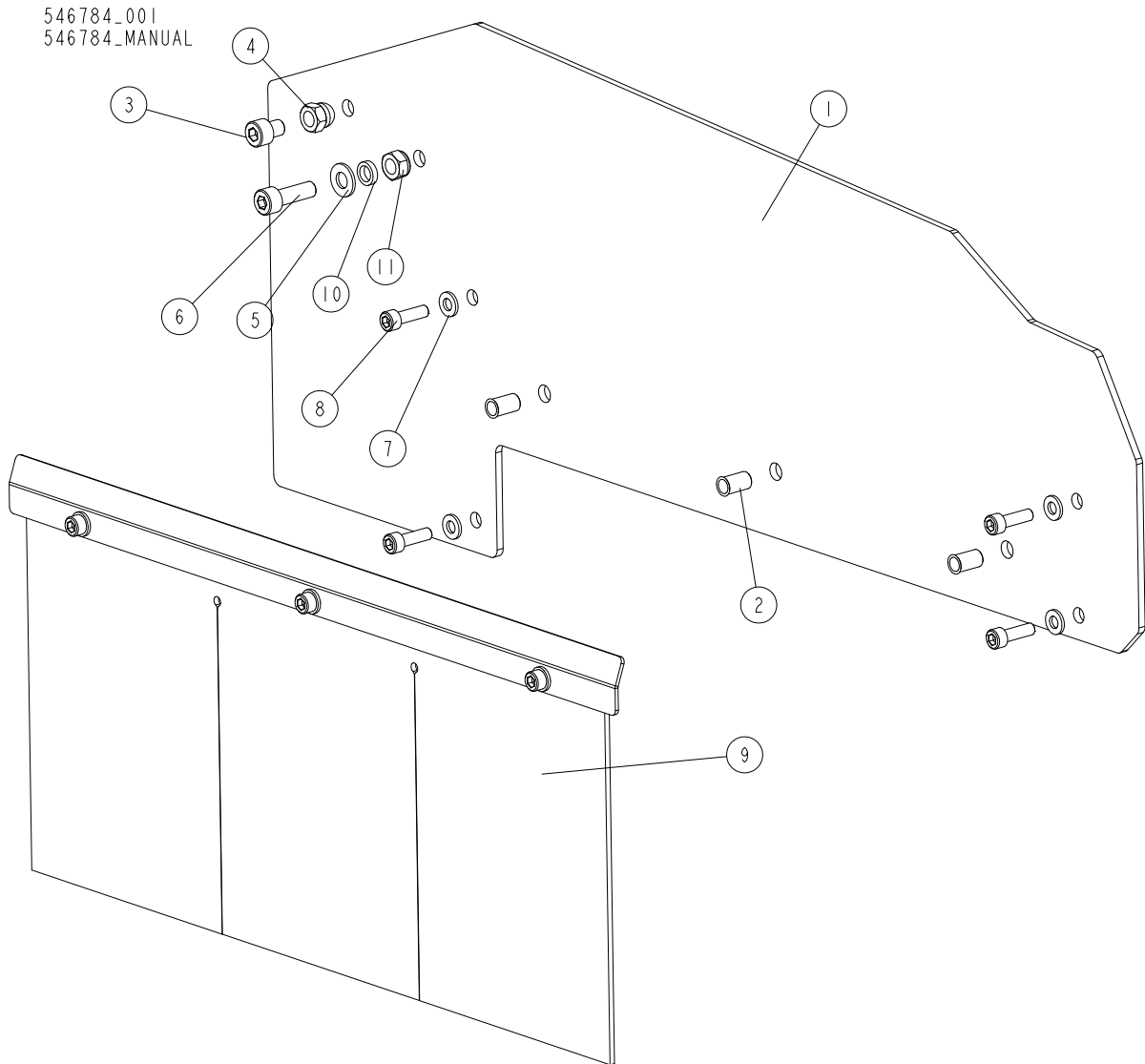

REF.	DESCRIPTION (* indicates parts available in assemblies only)	PART #	QTY
-	GUARD, COMPLETE LEFT	546784	1
1	PLATE, LEFT GUARD	546617-1	1
2	NUT, M6 1.5-4.0 MIN MTRG ZINC STEEL RIVET	F81031-13	3
3	SCREW, M8X10-8.8 HEX SOCKET HEAD CAP ZINC	F81002-32	1
4	NUT, M8 ZINC DOMED CAP	F81033-25	1
5	WASHER, 8.4 FLAT ZINC	F81054-1	1
6	SCREW, M8X25 -8.8 HEX SOCKET HEAD CAP ZINC	F81002-21	1
7	WASHER, 6.4 FLAT ZINC	F81053-1	4
8	SCREW, M6X20 8.8 HEX SOCKET HEAD CAP ZINC	F81001-22	4
9	GUARD, COMPLETE FLEXIBLE See Section 2.10	533729	1
10	BUSHING, SPACER	533674	1
11	NUT, M8-8-B HEX NYLON ZINC LOCK	F81032-2	1

2.10 Flexible Guard (No. 533729)

533729_001_A
533729_MANUAL

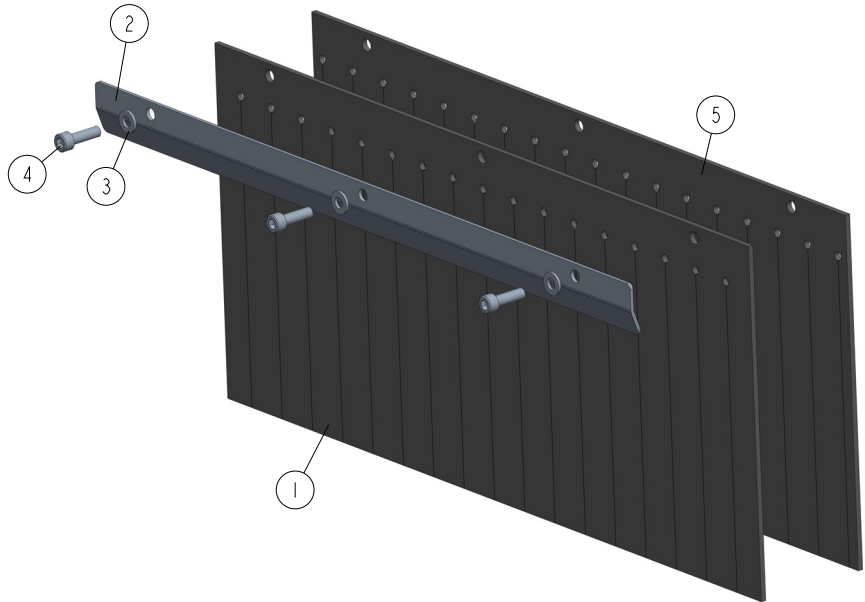

REF	DESCRIPTION (u indicates parts available in assemblies only)	PART #	QTY
-	GUARD, COMPLETE FLEXIBLE	533729	1
1	GUARD, FLEXIBLE	533083	1
2	BRACKET, FLEXIBLE GUARD	537551-1	1
3	WASHER, 6.4 FLAT ZINC	F81053-1	3
4	SCREW, M6X20 8.8 HEX SOCKET HEAD CAP ZIN	F81001-22	3
5	GUARD, FLEXIBLE	564886	1

2 Top Cover (No. 546613)

2.11 Top Cover (No. 546613)

546613_001_A
546613_MANUAL

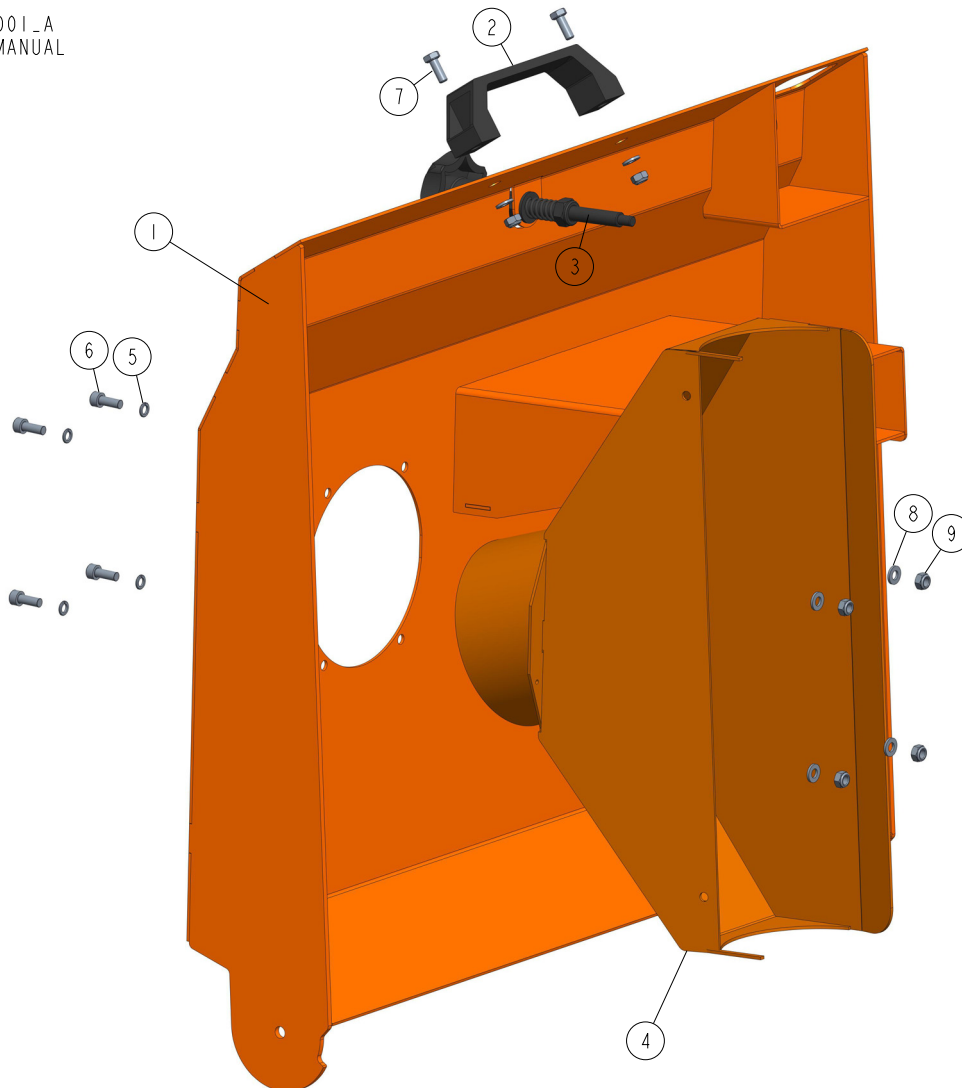

REF	DESCRIPTION (◆ indicates parts available in assemblies only)	PART #	QTY	
-	COVER, COMPLETE TOP	546613	1	
1	COVER WELDMENT - COMPLETE	546614-1	1	
2	HANDLE, PULL	533506	1	
3	KNOB ASSEMBLY, STAR See Section 2.12	546845	1	
4	OUTLET WELDMENT, SAWDUST	546608-1	1	
5	WASHER, Z 6.1 SPLIT LOCK ZINC	F81053-3	4	
6	SCREW, M6X16-8.8 HEX SOCKET HEAD CAP ZIN	F81001-21	4	
7	BOLT, M6X16 8.8 HEX HEAD FULL THREAD ZIN	F81001-15	2	
8	WASHER, 6.4 FLAT ZINC	F81053-1	6	
9	NUT, M6-8-B HEX NYLON LOCK ZINC	F81031-2	6	

2.12 Knob Assembly (No. 546845)

546845_001
546845_MANUAL

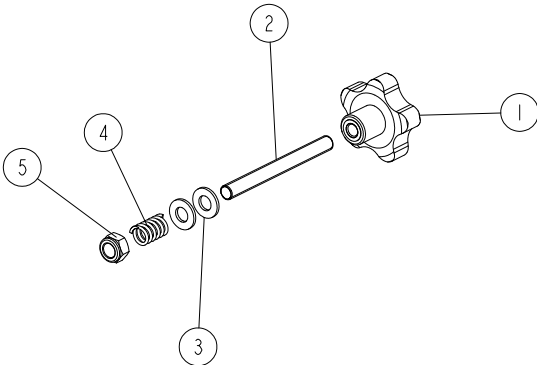

REF.	DESCRIPTION (* indicates parts available in assemblies only)	PART #	QTY	
-	KNOB ASSEMBLY, STAR	546845	1	
1	KNOB, GW M10 STAR	546844	1	
2	ROD, M10X100 THREADED	546843	1	
3	WASHER, 10.5 FLAT ZINC	F81055-1	2	
4	SPRING	533677	1	
5	NUT, M10-8-B HEX NYLON ZINC LOCK	F81033-1	1	

2.13 Cast-Iron Table (No. 546737)

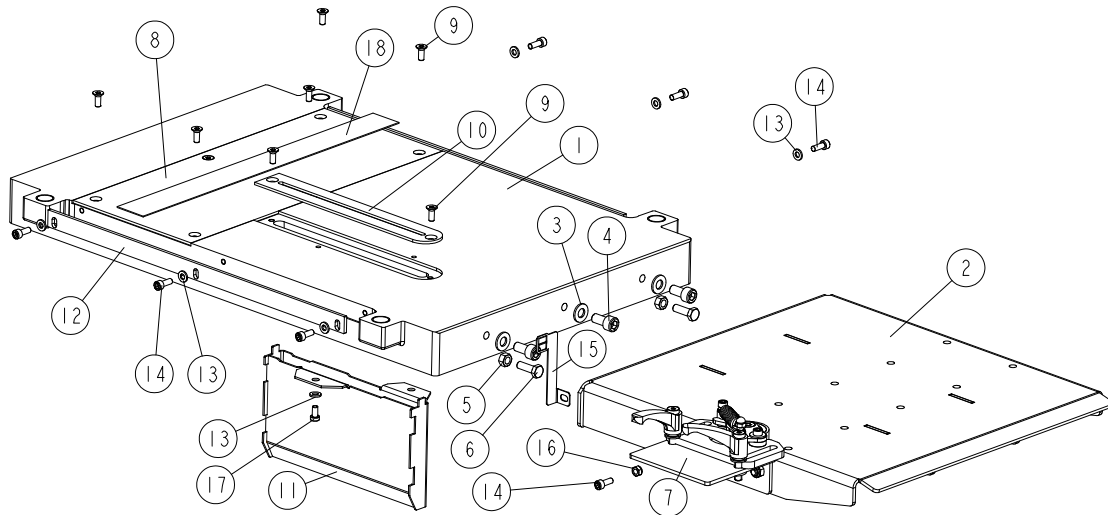
546737_001_A
546737_MANUAL

REF.	DESCRIPTION (* indicates parts available in assemblies only)	PART #	QTY
-	TABLE ASSEMBLY, CAST IRON	546737	1
1	TABLE, MP220 CAST IRON	546713-1	1
2	TABLE WELDMENT, INFEED	533665-1	1
3	WASHER, 10.5 FLAT ZINC	F81055-1	3
4	SCREW, M10X20 8.8 HEX SOCKET HEAD CAP ZINC	F81003-108	3
5	NUT, M8-8-B HEX ZINC	F81032-1	2
6	BOLT, M8X25-8.8-B HEX HEAD FULL THREAD ZINC	F81002-5	2
7	PRESS ROLLER ASSEMBLY See Section 2.14	533100	1
8	PLATE, SLIDE	592784	1
9	SCREW, M6X16-10.9 DIN7991 ISO10642 FLAT SOCKET HEAD CAP ZINC	F81001-55	8
10	PLATE, W/SLOT	546632	1
11	CHUTE WELDMENT, SAWDUST	546647-1	1
12	BAR	546835-1	2
13	WASHER, 6.4 FLAT ZINC	F81053-1	8
14	SCREW, M6X16 8.8 HEX SOCKET HEAD CAP ZINC	F81001-21	7
15	INDICATOR, TABLE HEIGHT SCALE	564883	1
16	NUT, M6-8-B HEX NYLON ZINC LOCK	F81031-2	1
17	SCREW, M6X12-10.9 DIN 7984 HEX SOCKET THIN HEAD CAP	F81001-80	2
18	STRIP, DOUBLE-SIDED ADHESIVE	535159	1

2.14 Press Roller Assembly (No. 533100)

533100_001
533100_MANUAL

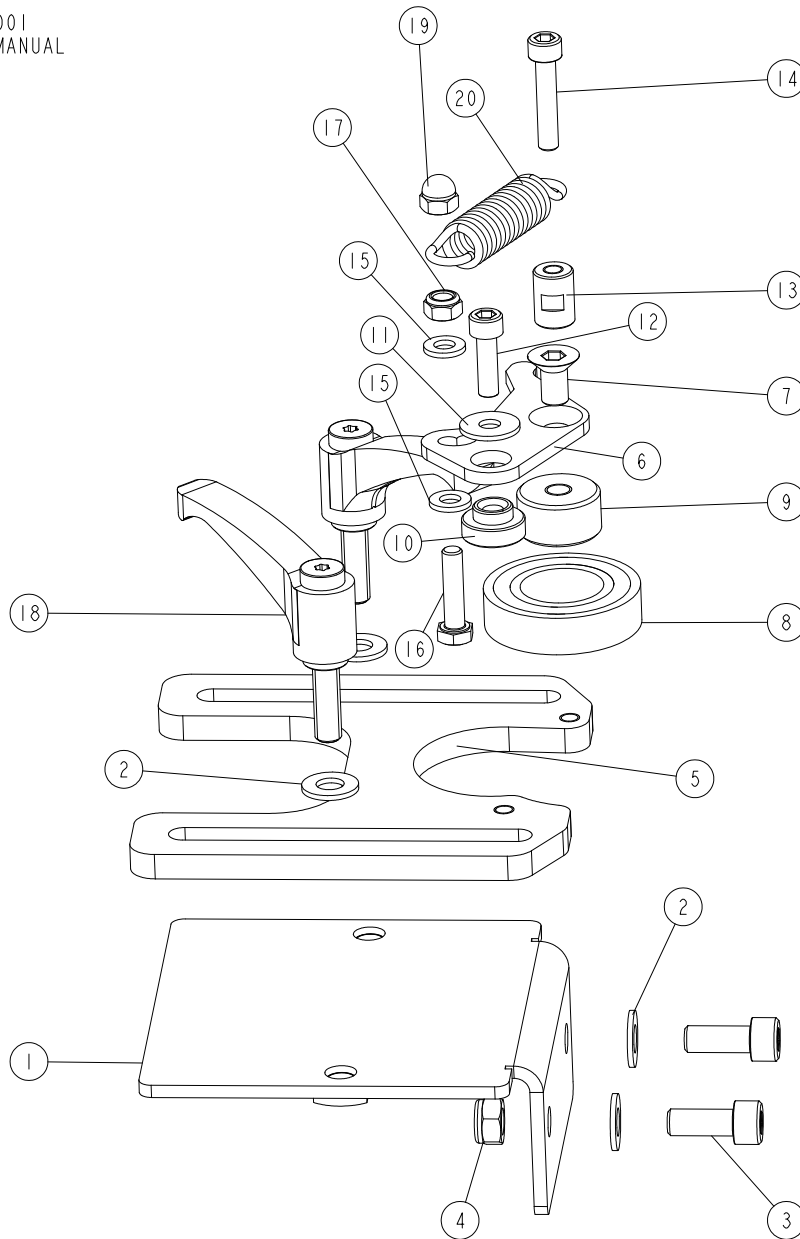

REF.	DESCRIPTION (* indicates parts available in assemblies only)	PART #	QTY
-	ROLLER ASSEMBLY, PRESS	533100	1
1	PLATE WELDMENT, MOUNT	533101-1	1
2	WASHER, 8.4 FLAT ZINC	F81054-1	4
3	SCREW, M8X20-8.8 HEX SOCKET HEAD CAP ZINC	F81002-30	2
4	NUT, M8-8-B HEX NYLON ZINC LOCK	F81032-2	2
5	PLATE, ADJUSTMENT	533103-1	1
6	BRACKET, BEARING MOVABLE	533525-1	1
7	SCREW, M8X16 FE/ZN5 7991 10.9 FLAT SOCKET HEAD CAP	F81002-82	1
8	BEARING, 6005 2RS	089652	1
9	BUSHING, M8/25-13.5 ZINC-PLATED	533529-1	1
10	BUSHING, 6.2/12-10 FLANGED 19-6	533632	1

REF.	DESCRIPTION (* indicates parts available in assemblies only)	PART #	QTY	
11	WASHER, 6.5 SPECIAL FLAT ZINC	F81053-11	1	
12	SCREW, M6X20 8.8 HEX SOCKET HEAD CAP ZINC	F81001-22	1	
13	BUSHING, M6/12-17 ZINC-PLATED	533633-1	1	
14	SCREW, M6X30-8.8 HEX SOCKET HEAD CAP ZINC	F81001-42	1	
15	WASHER, 6.4 FLAT ZINC	F81053-1	2	
16	BOLT, M6X25 -8.8 HEX HEAD FULL THREAD ZINC	F81001-3	1	
17	NUT, M6-8-B HEX NYLON ZINC LOCK	F81031-2	1	
18	LEVER, ERZ.63P-M8X25 ADJUSTABLE	533591	2	
19	NUT, DIN 1587 M6 FE/ZN5 HEX DOMED CAP	F81031-18	1	
20	SPRING, 15X65X2.5 EXTENSION	533571	1	

2.15 Guide Bar Assembly (No. 546715)

546715_001
546715_MANUAL

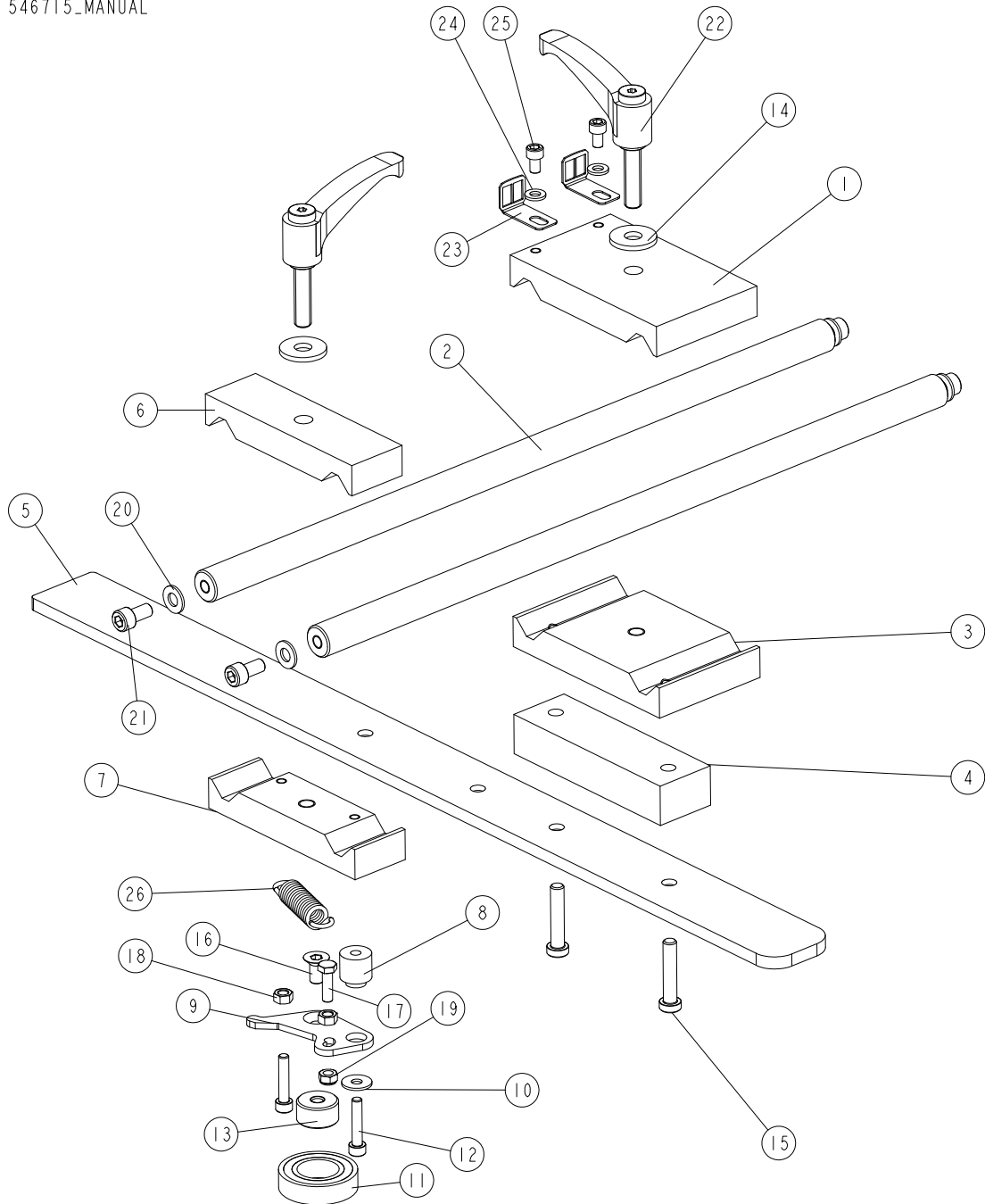

REF.	DESCRIPTION (* indicates parts available in assemblies only)	PART #	QTY
-	BAR ASSEMBLY, GUIDE	546715	1
1	BRACKET, ROD MOUNT - UPPER	533530-1	1
2	ROD, N20X494	533531-1	2
3	BRACKET, ROD MOUNT - LOWER	533523-1	1
4	BLOCK, 26X40X130 CONNECTION	533522-1	1
5	BAR, GUIDE	546894-1	1
6	PLATE, BASIC UPPER	533527-1	1

REF.	DESCRIPTION (* indicates parts available in assemblies only)	PART #	QTY
7	PLATE, BASIC LOWER	533526-1	1
8	BUSHING, 6.2/19-20.3 12-4.3	533528	1
9	BRACKET, BEARING MOVABLE	533525-1	1
10	WASHER, 6.5 SPECIAL FLAT ZINC	F81053-11	1
11	BEARING, 6005 2RS	089652	1
12	SCREW, M6X30-8.8 HEX SOCKET HEAD CAP ZINC	F81001-42	2
13	BUSHING, M8/25-13.5 ZINC-PLATED	533529-1	1
14	WASHER, 10.5 SPECIAL FLAT ZINC	F81055-6	2
15	SCREW, M8X40-8.8-FE/ZN5 DIN 7984 ISO 14580 HEX SOCKET THIN HEAD CAP	F81002-81	2
16	SCREW, M8X16-10.9 FE/ZN5 DIN7991 FLAT SOCKET HEAD CAP	F81002-82	1
17	BOLT, M6X20 8.8 HEX HEAD FULL THREAD ZINC	F81001-2	1
18	NUT, M6 8 HEX ZINC	F81031-1	2
19	NUT, M6-8-B HEX NYLON ZINC LOCK	F81031-2	1
20	WASHER, 8.4 FLAT ZINC	F81054-1	4
21	SCREW, M8X16-8.8 HEX SOCKET HEAD CAP ZINC	F81002-39	4
22	LEVER, ERZ.78 P-M10X40 ADJUSTABLE	533536	2
23	INDICATOR, SCALE	533098	2
24	WASHER, 6.4 FLAT ZINC	F81053-1	2
25	SCREW, M6X10 8.8 HEX SOCKET HEAD CAP ZINC	F81001-12	2
26	SPRING, 15X65X2.5 EXTENSION	533571	1

2.16 Feed Assembly (No. 546795)

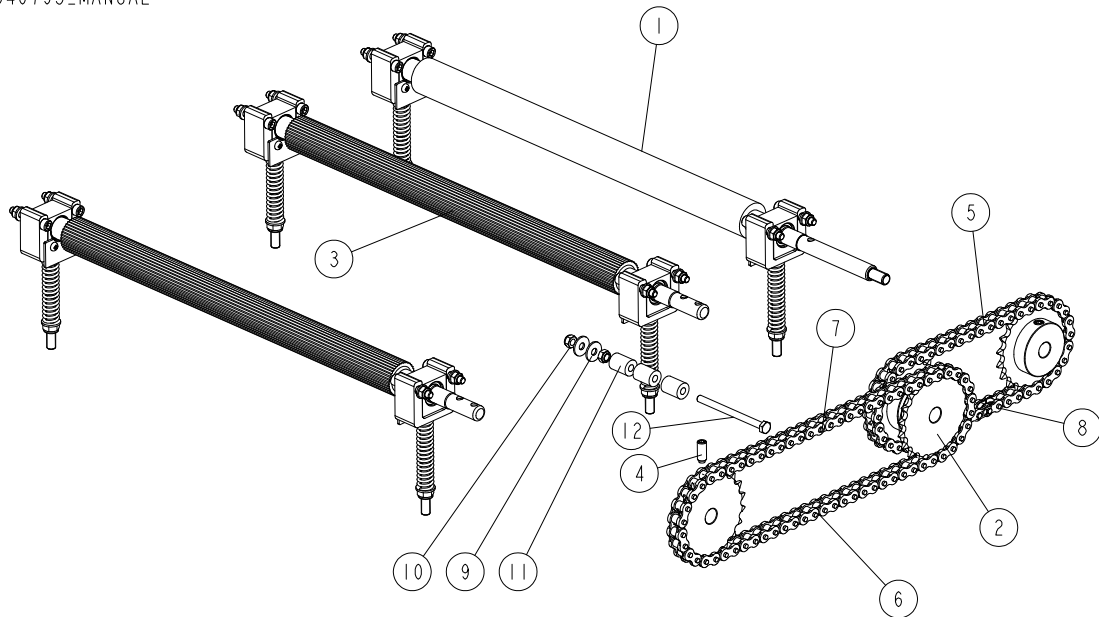
546795_001
546795_MANUAL

REF.	DESCRIPTION (* indicates parts available in assemblies only)	PART #	QTY
-	FEED ASSEMBLY, MP220	546795	1
1	SHAFT ASSEMBLY, W/PROTECTIVE COVER See Section 2.17	533581	1
2	SPROCKET, Z=20; 1/2"X 3/16" (CHAIN 083-1)	533109	4
3	SHAFT ASSEMBLY, DRIVE See Section 2.18	533580	2
4	SCREW, M8X20 -45H- PN-EN-ISO 4028 ; DIN915 HEX SOCKET SET W/DOG POINT	F81002-77	4
5	CHAIN, 083-1; P=1/2"; LENGTH L=606 MM (43-LINK)	546796	1
6	CHAIN, 083-1; P=1/2"; LENGTH L=847 MM (63-LINK)	546797	1
7	LINK, 083-1 MASTER	533128	2
8	LINK, 083-1 HALF	533129	1
9	WASHER, 6.5 SPECIAL FLAT ZINC	F81053-11	2
10	NUT, M6-8-B HEX NYLON ZINC LOCK	F81031-2	2
11	BUSHING, SPACER	R80671-6	3
12	BOLT, M6X80 8.8 HEX HEAD FULL THREAD ZINC	F81001-61	1

2.17 Shaft w/Protective Cover (No. 533581)

533581_001_A
533581_MANUAL

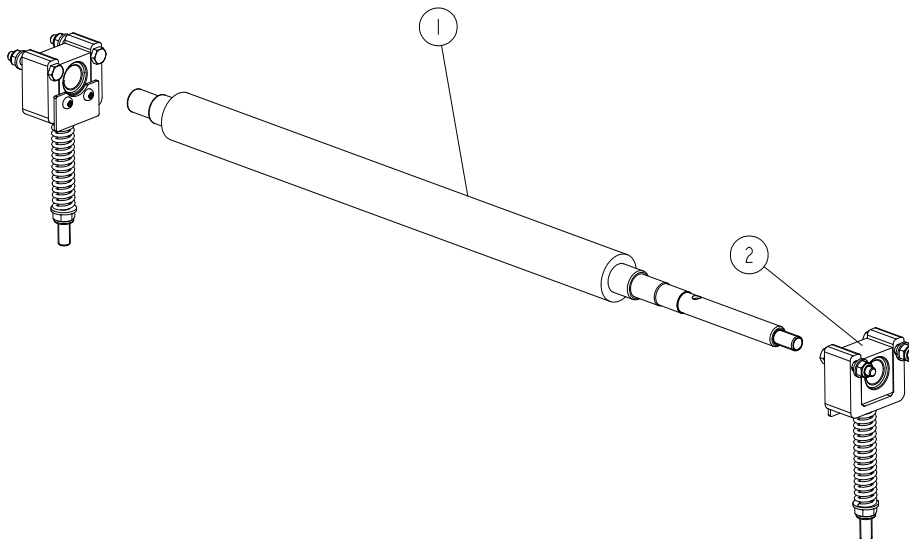

REF.	DESCRIPTION (* indicates parts available in assemblies only)	PART #	QTY	
-	SHAFT ASSEMBLY, W/PROTECTIVE COVER	533581	1	
1	SHAFT W/PROTECTIVE COVER	533512	1	
2	BEARING ASSEMBLY, SLIDE See Section 2.19	533520	2	

2.18 Drive Shaft Assembly (No. 533580)

533580_001_A
533580_MANUAL

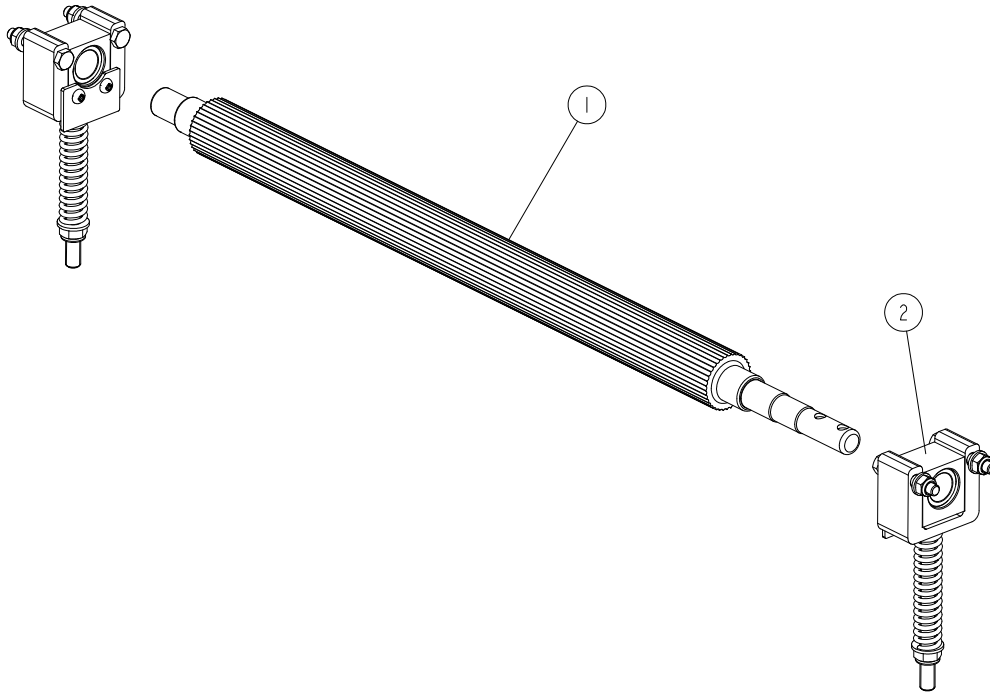

REF.	DESCRIPTION (* indicates parts available in assemblies only)	PART #	QTY	
-	SHAFT ASSEMBLY, DRIVE	533580	1	
1	SHAFT, STEEL DRIVE	533513-1	1	
2	BEARING ASSEMBLY, SLIDE See Section 2.19	533520	2	

2.19 Slide Bearing Assembly (No. 533520)

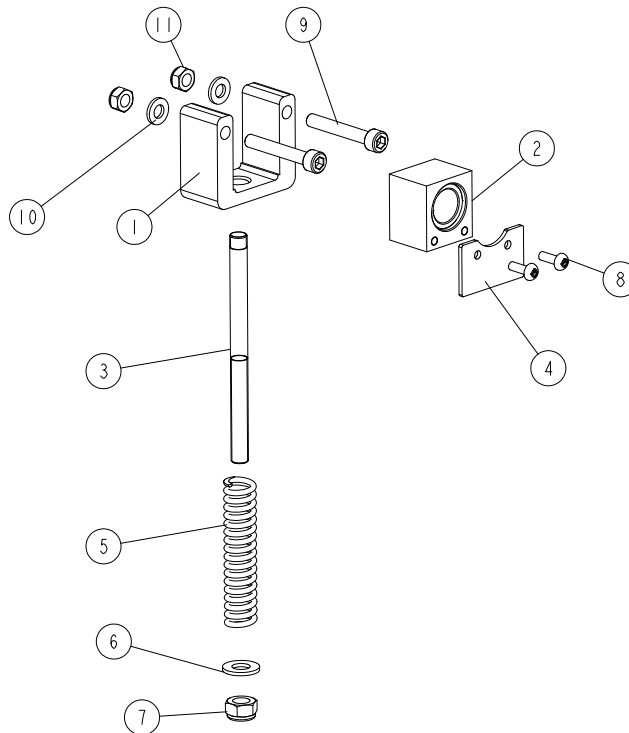
533520_001_B
533520_MANUAL

REF	DESCRIPTION (◆ indicates parts available in assemblies only)	PART #	QTY
-	BEARING ASSEMBLY, SLIDE	533520	1
1	HOUSING, SLIDE BEARING	533514	1
2	SLIDE BLOCK ASSEMBLY	537575	1
3	ROD, SHAFT TENSION	546898-1	1
4	COVER, RUBBER	533516	1
5	SPRING	533519-1	1
6	WASHER, 8.4 FLAT,ZINC	F81054-1	1
7	NUT, M8-8-B HEX NYLON ZINC LOCK	F81032-2	1
8	SCREW M4X12 PHILLIPS ZC 5.8 DIN 7985	F81011-43	2
9	BOLT M6X40 HEX	F81001-124	2
10	WASHER, M6, FLAT,ZINC	F81053-1	2
11	NUT, M6-8-B HEX NYLON ZINC LOCK	F81031-2	2

2.20 Up/Down Assembly (No. 546738)

546738_001_A
546738_MANUAL

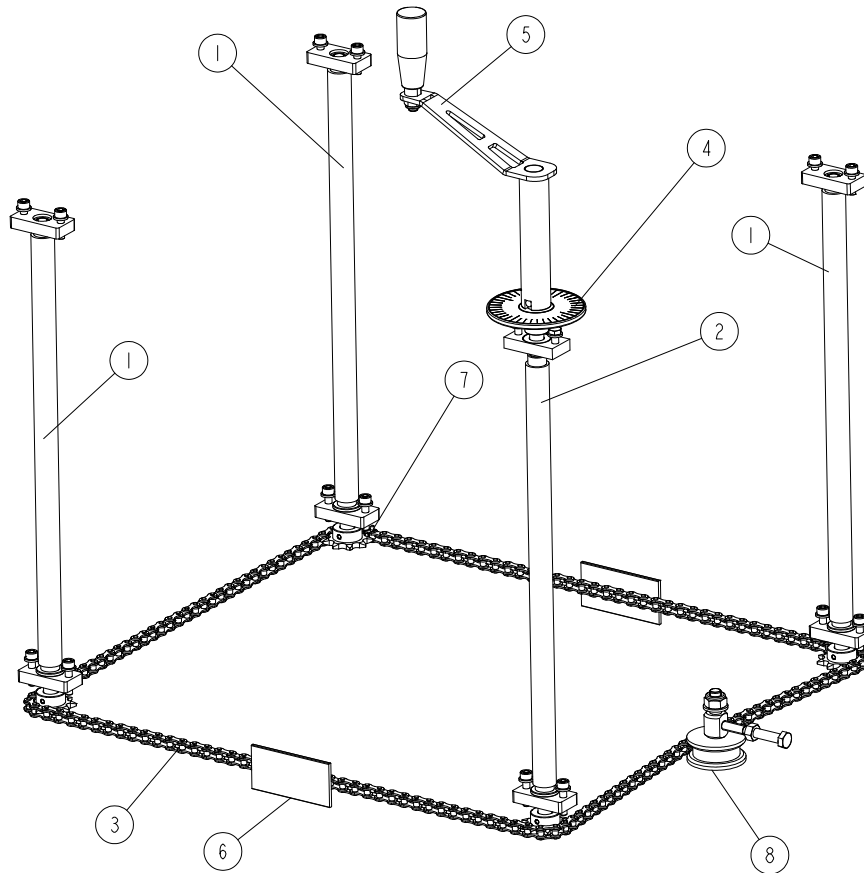

REF.	DESCRIPTION (* indicates parts available in assemblies only)	PART #	QTY
-	UP/DOWN ASSEMBLY	546738	1
1	SCREW ASSEMBLY, ACME LEAD - SHORT See Section 2.21	546716	3
2	SCREW ASSEMBLY, ACME LEAD - LONG See Section 2.22	546718	1
3	CHAIN, 083-1; P=1/2" LENGTH 2006.6 MM (158-LINK)	547241	1
4	SCALE, COMPLETE ROUND See Section 2.23	533676	1
5	HANDLE, TABLE SETTING - COMPLETE See Section 2.24	542521	1
6	TAPE, SLIDE	537562	2
7	LINK, 083-1 HALF	533129	1
8	TENSIONER, CHAIN - COMPLETE See Section 2.25	534390	1

2.21 Short Acme Screw Assembly (No. 546716)

546716_001_B
546716_MANUAL

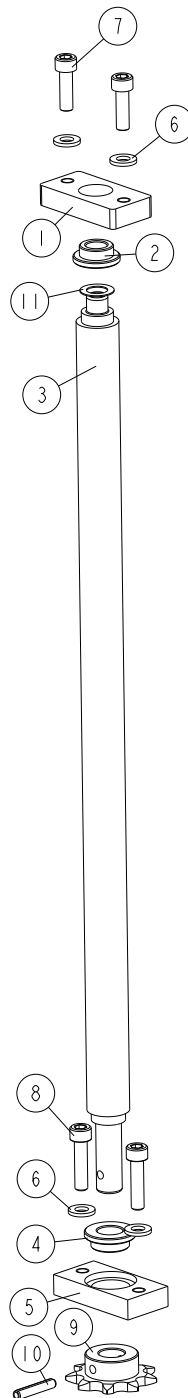

REF.	DESCRIPTION (* indicates parts available in assemblies only)	PART #	QTY
-	SCREW ASSEMBLY, ACME LEAD - SHORT	546716	1
1	PLATE, ACME SCREW MOUNT - UPPER	546637-1	1
2	BUSHING, 10/16-8 FLANGED 22-3	546902	1
3	SCREW, ACME LEAD - SHORT	546635	1
4	BUSHING, 12/18-8 FLANGE 24-3	546901	1

REF.	DESCRIPTION (* indicates parts available in assemblies only)	PART #	QTY	
5	BLOCK	533113-1	1	
6	WASHER, 6.4 FLAT ZINC	F81053-1	4	
7	SCREW, M6X20 8.8 HEX SOCKET HEAD CAP ZINC	F81001-22	2	
8	SCREW, M6X25-8.8 HEX SOCKET HEAD CAP ZINC	F81001-41	2	
9	SPROCKET, Z=9; 1/2"X 3/16" (CHAIN 083-1)	533111	1	
10	PIN, 4X24 ZINC-PLATED SPRING TYPE	F81044-13	1	
11	THIN WASHER 10/16-0.5	535990	1	

2.22 Long Acme Screw Assembly (No. 546718)

546718_001_A
546718_MANUAL

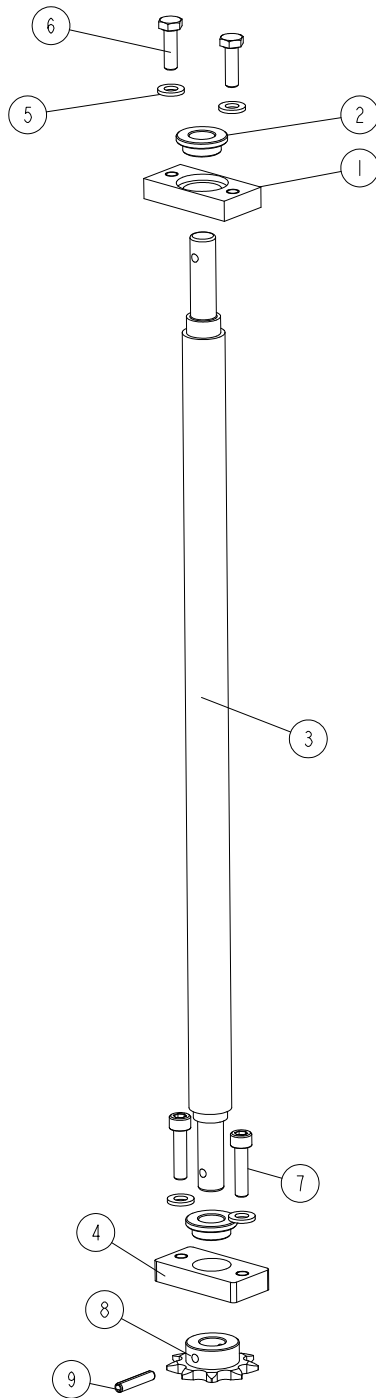

REF.	DESCRIPTION (* indicates parts available in assemblies only)	PART #	QTY	
-	SCREW ASSEMBLY, ACME LEAD - LONG	546718	1	
1	BLOCK	533113-1	1	
2	BUSHING, 12/18-8 FLANGE 24-3	546901	2	
3	SCREW, ACME LEAD - LONG	546634	1	
4	PLATE, ACME SCREW MOUNT - LOWER	546636-1	1	

REF.	DESCRIPTION (* indicates parts available in assemblies only)	PART #	QTY	
5	WASHER, 6.4 FLAT ZINC	F81053-1	4	
6	BOLT, M6X20 8.8 HEX HEAD FULL THREAD ZINC	F81001-2	2	
7	SCREW, M6X25-8.8 HEX SOCKET HEAD CAP ZINC	F81001-41	2	
8	SPROCKET, Z=9; 1/2"X 3/16" (CHAIN 083-1)	533111	1	
9	PIN, 4X24 ZINC-PLATED SPRING TYPE	F81044-13	1	

2.23 Round Scale (No. 533676)

533676_001_A
533676_MANUAL

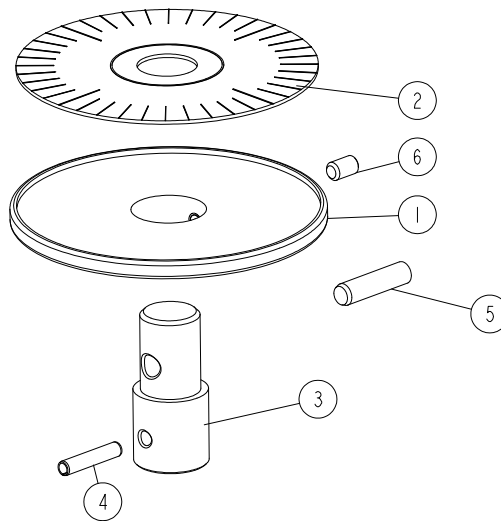

REF.	DESCRIPTION (* indicates parts available in assemblies only)	PART #	QTY	
-	SCALE, COMPLETE ROUND	533676	1	
1	DISK, ROUND SCALE	533594	1	
2	DECAL, MP200 ROUND SCALE	533577	1	
3	PIN, SCALE DISK MOUNT	533595-1	1	
4	PIN, PN-EN ISO 8752-4X20-ST-A0P SPRING-TYPE	F81044-11	1	
5	PIN, ISO2338- 6M6X24-A1 DOWEL	F81045-5	1	
6	SCREW, M5X8 45H DIN 913 HEX SOCKET SET W/FLAT POINT	F81014-7	1	

2.24 Handle Assembly (No. 542521)

542521_001
542521_MANUAL

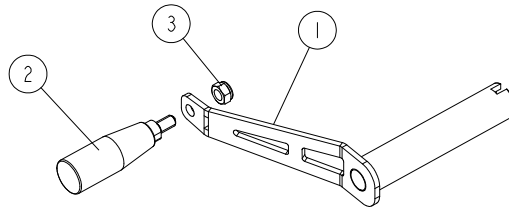

REF.	DESCRIPTION (* indicates parts available in assemblies only)	PART #	QTY	
-	HANDLE, COMPLETE	542521	1	
1	HANDLE	542522-1	1	
2	GRIP, CYLINDRICAL	533505	1	
3	NUT, M8-8-B HEX NYLON ZINC LOCK	F81032-2	1	

2.25 Chain Tensioner (No. 534390)

534390_001
534390_MANUAL

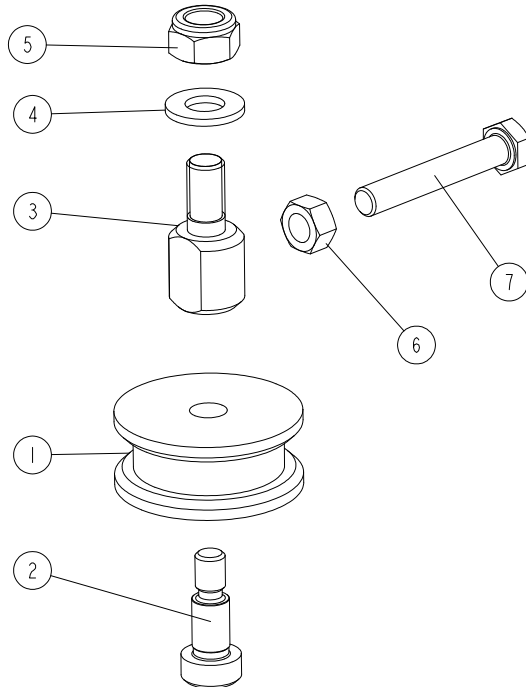

REF.	DESCRIPTION (* indicates parts available in assemblies only)	PART #	QTY
-	TENSIONER, CHAIN - COMPLETE	534390	1
1	ROLLER, CHAIN TENSIONER	533576	1
2	BOLT, ISO 7379-10-M8-16 12.9 SHOULDER	F81003-139	1
3	BOLT, MOUNTING	534388-1	1
4	WASHER, 10.5 FLAT ZINC	F81055-1	1
5	NUT, M10-8-B HEX NYLON ZINC LOCK	F81033-1	1
6	NUT, M8-8-B HEX ZINC	F81032-1	1
7	BOLT, M8X50 -8.8 HEX HEAD FULL THREAD ZINC	F81002-19	1

2.26 Anti-Kickback Fingers (No. 533125)

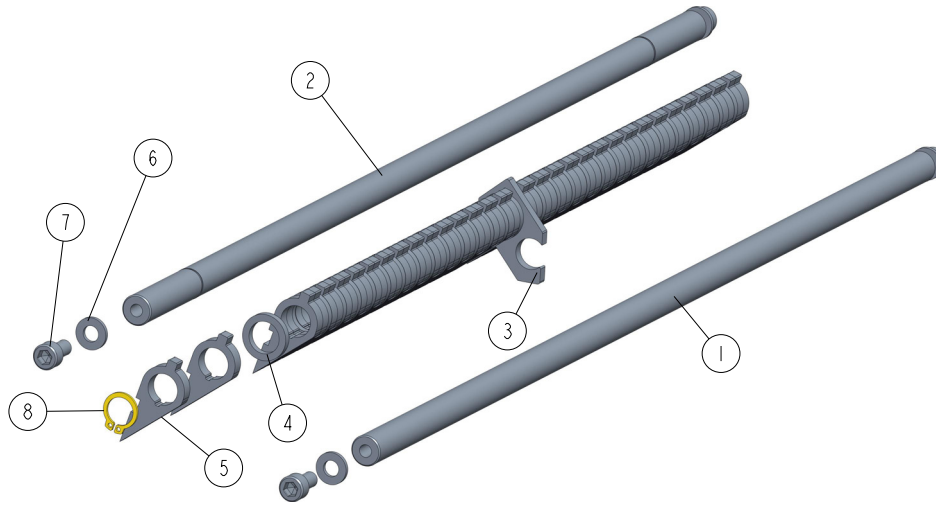
533125_001_B
533125_MANUAL

REF	DESCRIPTION (◆ indicates parts available in assemblies only)	PART #	QTY	
-	ANTI-KICKBACK FINGERS ASSEMBLY	533125	1	
1	SHAFT	533092-1	1	
2	SHAFT, ANTI-KICKBACK FINGER ZINC	546931-1	1	
3	PLATE	533124-1	1	
4	WASHER, DIA.1940	533123	30	
5	ANTI-KICKBACK FINGER	533126	30	
6	WASHER, M6, FLAT,ZINC	F81053-1	4	
7	SCREW M6X12 SHCS ZC 8.8 DIN 912 ISO 4762	F81001-87	4	
8	RING, Z12 OUTSIDE RETAINING	F81090-14	2	

2.27 Cutter Assembly (No. 542485)

542485_001_A
542485_MANUAL

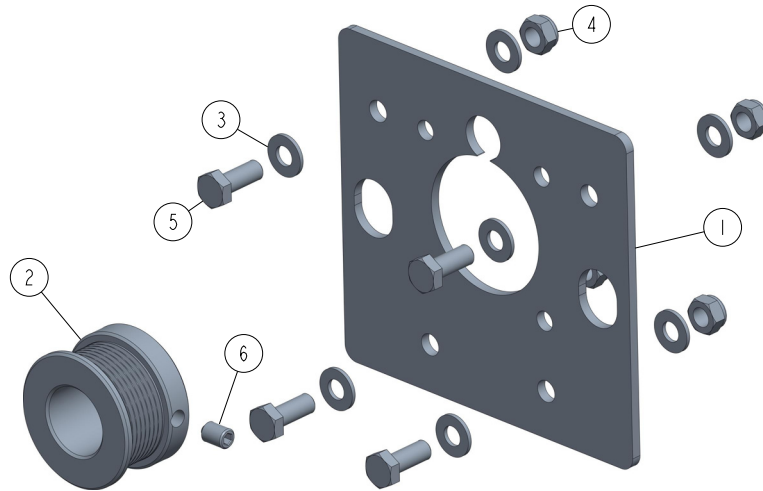

REF	DESCRIPTION (◆ indicates parts available in assemblies only)	PART #	QTY	
-	CUTTER ASSEMBLY	542485	1	
1	PLATE, CUTTER MOUNT	546631-1	1	
2	PULLEY, MULTI-GROOVE SMALL	601602	1	
3	WASHER, 8.4 FLAT ZINC	F81054-1	8	
4	NUT, M8-8-B HEX NYLON ZINC LOCK	F81032-2	4	
5	BOLT, M8X20-8.8-B HEX HEAD FULL THREAD Z	F81002-4	4	
6	SCREW, M8X12-45H FE/ZN DIN914 HEX SOCKET	F81002-105	1	

2.28 Main Shaft Assembly (533682)

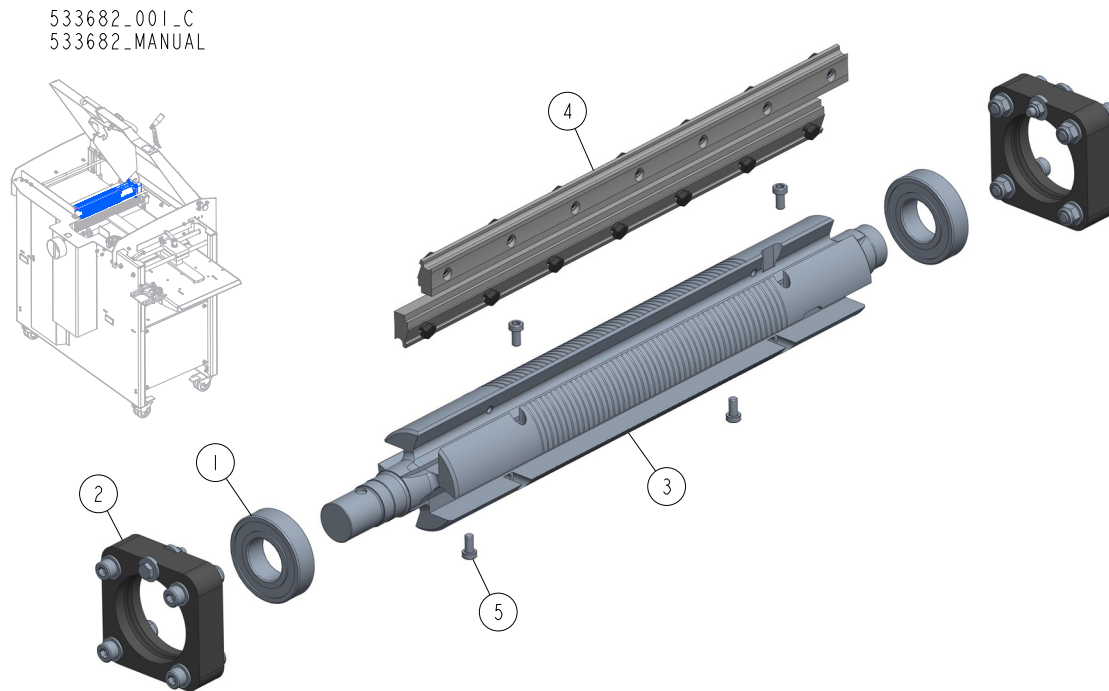

REF	DESCRIPTION (◆ indicates parts available in assemblies only)	PART #	QTY	
-	SHAFT ASSEMBLY, DRIVE	533682	1	
1	BEARING, 6206 2RSR P6 ROLLING	100787	2	
2	HOUSING ASSEMBLY, BEARING See Section 2.30	533593	2	
-	SHAFT ASSEMBLY, MAIN	564943	1	
3	SHAFT, MAIN	260-138	1	
4	MOUNTING WEDGES	241-060	1	
5	SCREW, M6X12-10.9 DIN 7984 HEX SOCKET TH	F81001-80	4	

2.29 Helical Top Cutter Assembly THH220TC-S (Option)

THH220TC-S_001
THH220TC-S

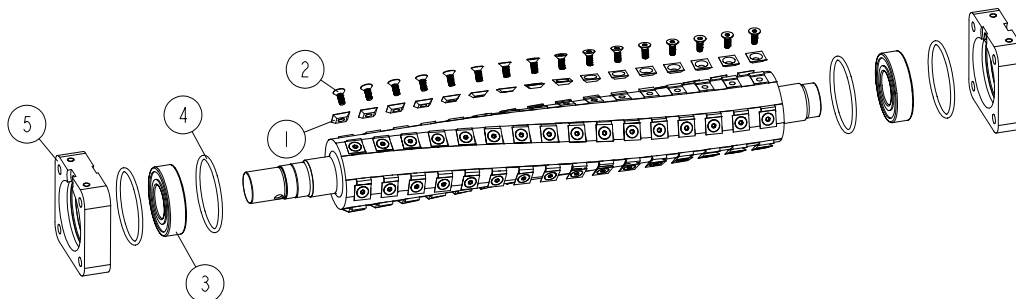

REF	DESCRIPTION (◆ indicates parts available in assemblies only)	PART #	QTY	
-	KIT, MP220 HELICAL TOP CUTTERHEAD	THH220TC-S	1	
-	CUTTERHEAD, HELICAL THH260TC	THH260TC	1	
1	INSERT, REPLACEMENT CARBIDE	TIK19HM	80	
2	SCREW, 10-32X1/2 FH BO; TORX PLUS	F05004-325	80	
3	BEARING, 6206 2RSR P6 ROLLING (FAG, NSK,	100787	2	
4	O-RING, BEARING HOUSING	533592	4	
5	HOUSING, BEARING	533590-1	2	

2.30 Bearing Housing Assembly (No. 533593)

533593_001
533593_MANUAL

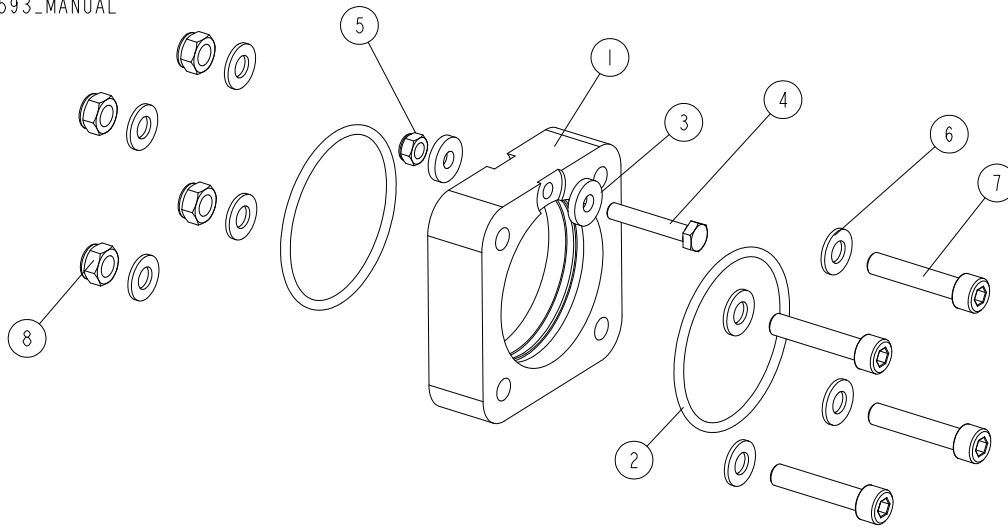

REF.	DESCRIPTION (* indicates parts available in assemblies only)	PART #	QTY
-	HOUSING ASSEMBLY, BEARING	533593	1
1	HOUSING, BEARING	533590-1	1
2	O-RING, BEARING HOUSING	533592	2
3	WASHER, 6.4 FE/ZN DIN 7349 SPACER	F81053-13	2
4	BOLT, M6X35 -8.8 HEX HEAD ZINC	F81001-71	1
5	NUT, M6-8-B HEX NYLON ZINC LOCK	F81031-2	1
6	WASHER, 8.4 FLAT ZINC	F81054-1	8
7	SCREW, M8X40-8.8 HEX SOCKET HEAD CAP ZINC	F81002-29	4
8	NUT, M8-8-B HEX NYLON ZINC LOCK	F81032-2	4

2.31 Reinforcing Bracket Assembly (No. 546724)

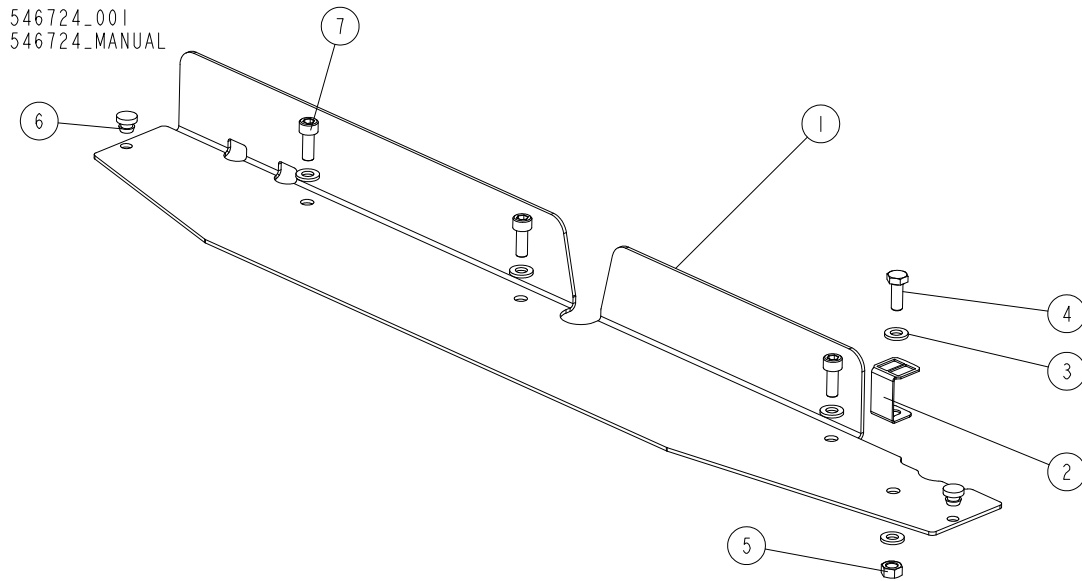

REF.	DESCRIPTION (* indicates parts available in assemblies only)	PART #	QTY
-	BRACKET ASSEMBLY, REINFORCEMENT	546724	1
1	BRACKET, REINFORCEMENT	546623-1	1
2	INDICATOR, SCALE	546624-1	1
3	WASHER, 6.4 FLAT ZINC	F81053-1	5
4	BOLT, M6X16-8.8 HEX HEAD FULL THREAD ZINC	F81001-15	1
5	NUT, M6 8 HEX ZINC	F81031-1	1
6	FEET, SRI591 12X6 GROMMET	101279	2
7	SCREW, M6X16 8.8 HEX SOCKET HEAD CAP ZINC	F81001-21	3

2.32 Circular Blade Assembly (No. 546714)

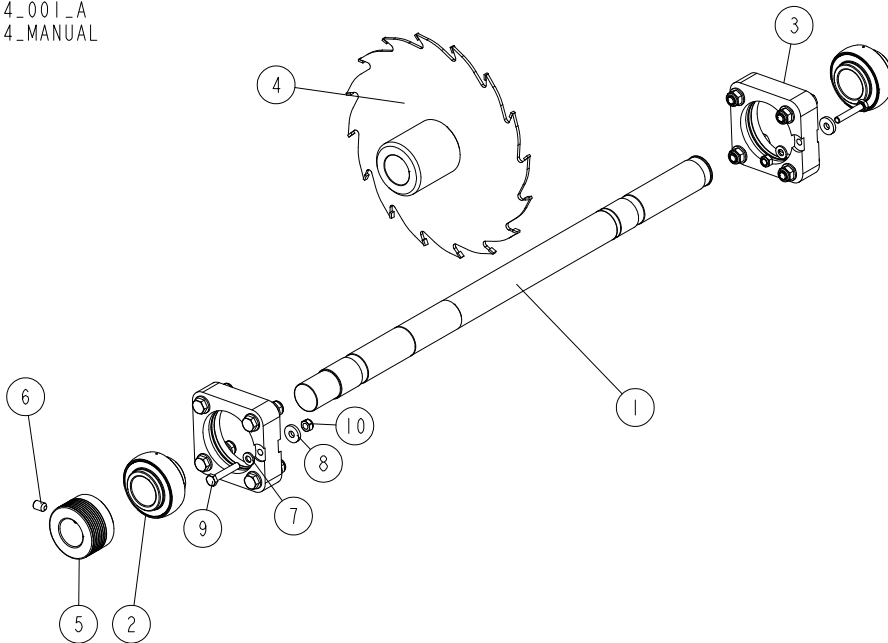
546714_001_A
546714_MANUAL

REF	DESCRIPTION (◆ indicates parts available in assemblies only)	PART #	QTY	
-	BLADE ASSEMBLY	546714	1	
1	SHAFT, BLADE	546630	1	
2	BEARING, UC206	542481	2	
3	HOUSING ASSEMBLY, SHAFT BEARING	542483	2	
4	BLADE W/MOUNTING BUSHING	546627	1	
5	SHEAVE, MULTI-GROOVE	542482	1	
6	SCREW, M8X12-45H FE/ZN DIN914/ PN82315 H	F81002-105	1	
7	WASHER, M6, FLAT,ZINC	F81053-1	2	
8	WASHER 6,4 ZC DIN 7349	F81053-13	2	
9	BOLT, M6X35 8.8 HEX HEAD ZINC	F81001-71	2	
10	NUT,M6-8-B HEX,NYLON LOCK ZINC	F81031-2	2	

2.33 Bearing Housing Assembly (No. 542483)

542483_001_A
542483_MANUAL

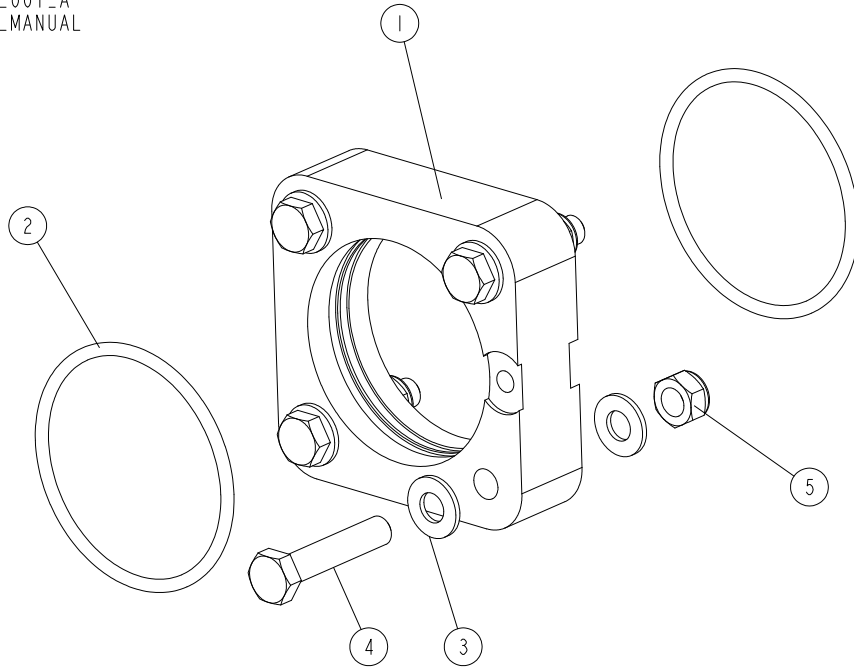

REF	DESCRIPTION (◆ indicates parts available in assemblies only)	PART #	QTY	
-	HOUSING ASSEMBLY, SHAFT BEARING	542483	1	
1	HOUSING, BEARING	533590-1	1	
2	O-RING, BEARING HOUSING	533592	2	
3	WASHER, 8.4 FLAT ZINC	F81054-1	8	
4	BOLT, M8X40-8.8 HEX HEAD FULL THREAD ZIN	F81002-15	4	
5	NUT, M8 8 HEX NYLON ZINC LOCK	F81032-2	4	

2.34 Blade w/Mounting Bushing (No. 546627)

546627_001
546627_MANUAL

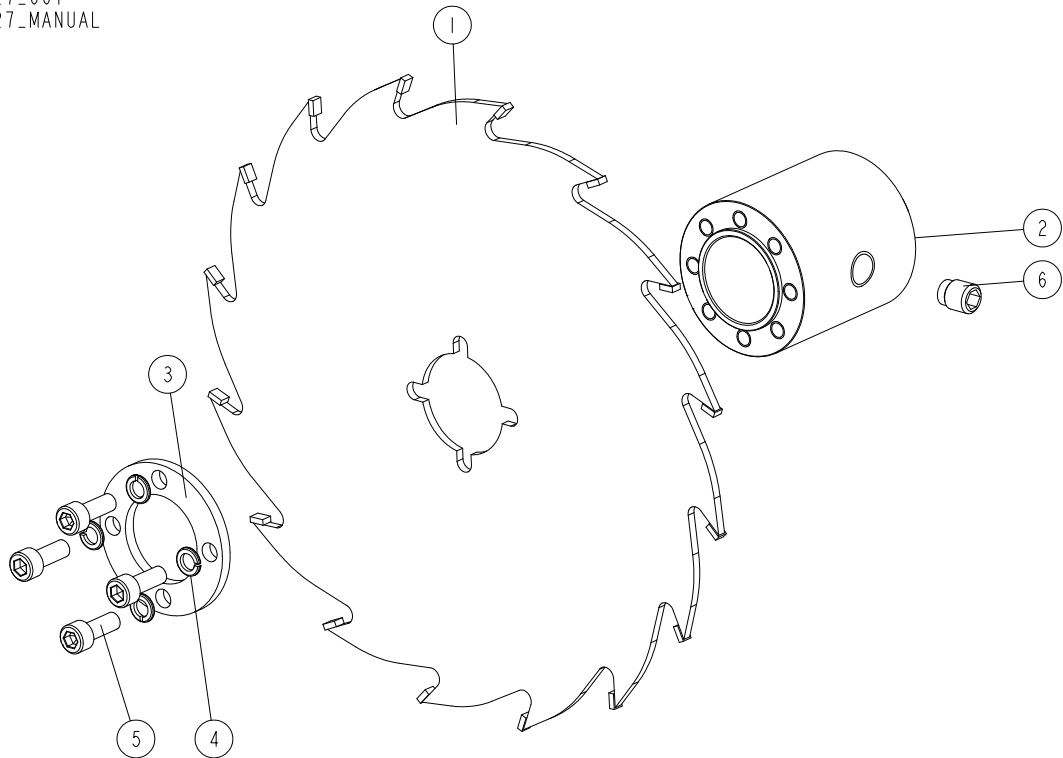

REF.	DESCRIPTION (* indicates parts available in assemblies only)	PART #	QTY	
-	BLADE W/MOUNTING BUSHING	546627	1	
1	BLADE, 225X3.5X2.5X35 TMB225-016-35 CIRCULAR		1	
2	BUSHING , BLADE MOUNTING	546629-1	1	
3	COLLAR, CLAMPING	546628-1	1	
4	WASHER, Z 6.1 SPLIT LOCK ZINC	F81053-3	4	
5	SCREW, M6X16 8.8 HEX SOCKET HEAD CAP ZINC	F81001-21	4	
6	SCREW, M12X12 - ISO4028-45H-IS6 HEX SOCKET SET W/DOG POINT	F81004-168	1	

2.35 Outfeed Table Extension (No. 546935)

546935_001
546935_MANUAL

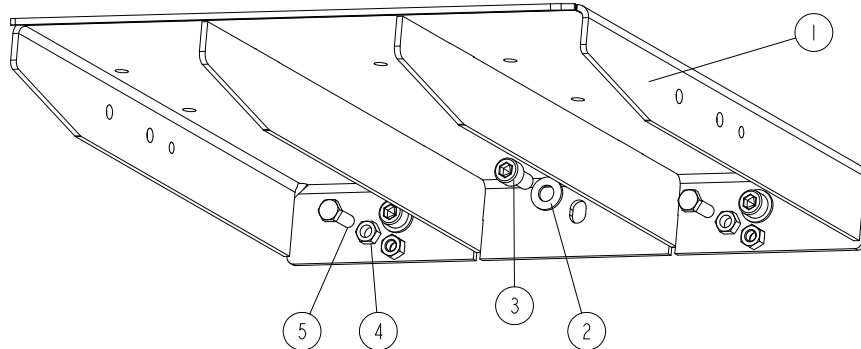

REF	DESCRIPTION (◆ indicates parts available in assemblies only)	PART #	QTY
-	EXTENSION, OUTFEED TABLE	546935	1
1	TABLE, INFEED WLDMT/PTD	533665-1	1
2	WASHER, 10.5 FLAT ZINC	F81055-1	3
3	SCREW M10X20 SHCS ZC 8.8 DIN 912 ISO4762	F81003-108	3
4	NUT, M8 HEXAGON, GRADE 5.8 FREE ZINC	F81032-1	2
5	BOLT, M8X25-8.8-B HEX HEAD FULL THREAD ZI	F81002-5	2

2.36 Material Guide Assembly (option)

554101_001
554101_MANUAL

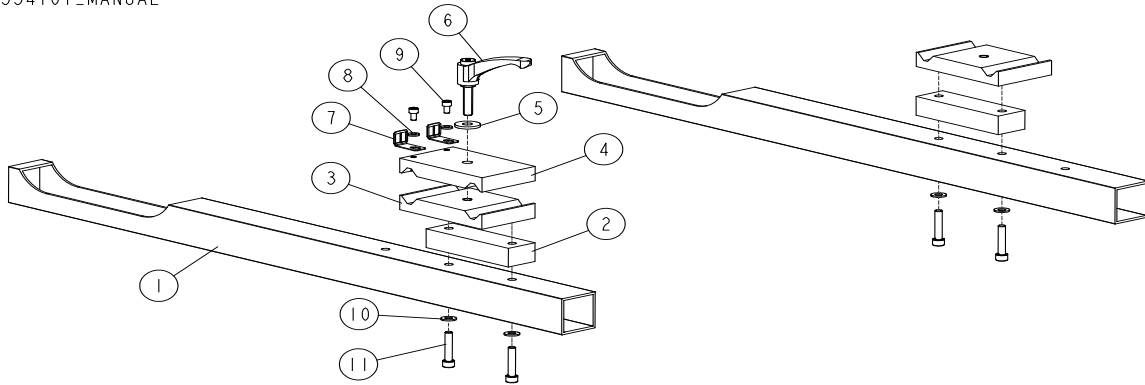

REF	DESCRIPTION (u indicates parts available in assemblies only)	PART #	QTY
-	Material Guide Assembly	554101	1
1	MATERIAL GUIDE	554100-1	2
2	BLOCK, 26X40X130 CONNECTION	533522-1	2
3	BRACKET, ROD MOUNT - LOWER	533523-1	2
4	BRACKET, ROD MOUNT - UPPER	533530-1	1
5	WASHER, 10.5 SPECIAL FLAT ZINC	F81055-6	1
6	HANDLE, ERZ.78 P-M10X40 ADJUSTABLE	533536	1
7	INDICATOR, SCALE	533098	2
8	WASHER, 6.4 FLAT ZINC	F81053-1	2
9	SCREW, M6X10 8.8 HEX SOCKET HEAD CAP ZIN	F81001-12	2
10	WASHER, 8.4 FLAT ZINC	F81054-1	4
11	SCREW, M8X40-8.8 HEX SOCKET HEAD CAP ZIN	F81002-29	4

2.37 Tabler Infeed-Outfeed (546940)

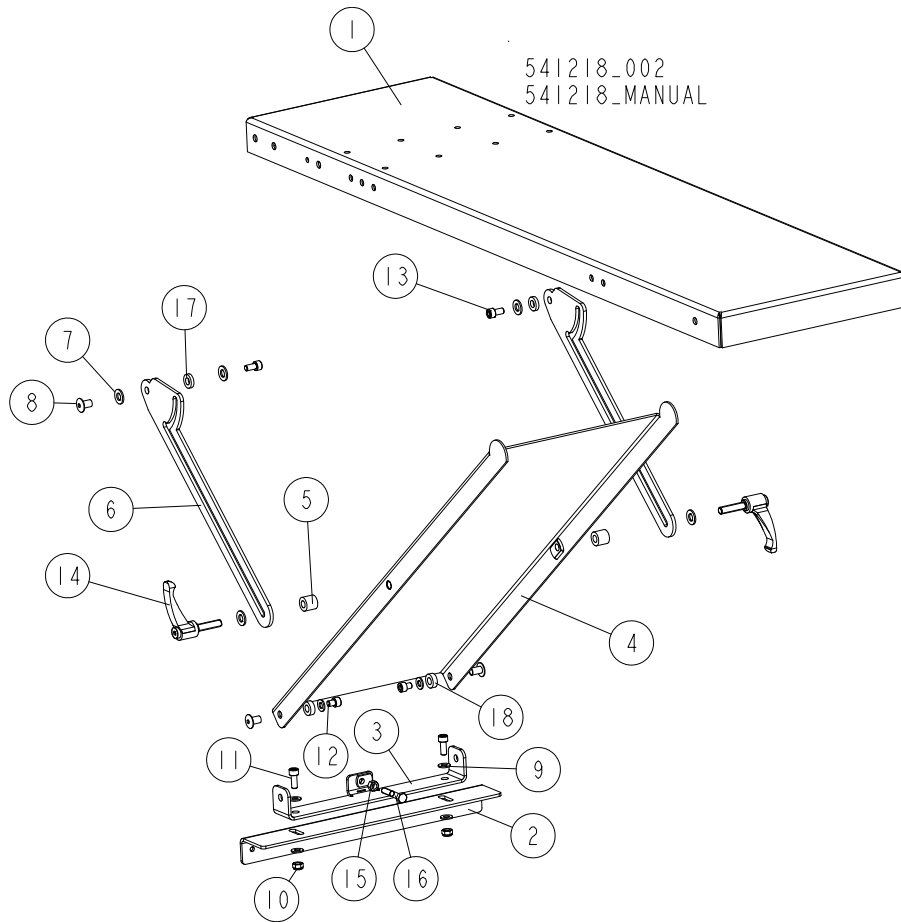

REF	DESCRIPTION (◆ indicates parts available in assemblies only)	PART #	QTY
-	TABLER INFEED-OUTFEED	546940	1
1	PLATE, TABLE 265	541260-1	1
2	ANGLE SECTION	265-104-1	1
3	CHANNEL BAR, MP260 WELDMENT	541453-1	1
4	PLATE, SUPPORTING 280 - COMPLETE	541251-1	1
5	SPACER. 10.2/20-18	541249	2
6	SLIDER	541248-1	2
7	WASHER, 10.5 FLAT ZINC	F81055-1	6
8	NUT, ERICSON M8 AN88 COLLAR ZINC	F81032-33	4
9	WASHER, 8.4 FLAT ZINC	F81054-1	6
10	NUT, M8-8-B HEX NYLON ZINC LOCK	F81032-2	2
11	BOLT, M8 X 20-8.8 SOCKET HEAD	F81002-30	2
12	SCREW, M8X10-8.8-FE/ZN5 HEX SOCKET HEA	F81002-32	2
13	SCREW, M8X16-8.8 HEX SOCKET HEAD CAP ZIN	F81002-39	2
14	HANDLE, ERZ.78 P-M10X40 ADJUSTABLE	533536	2
15	NUT, M8-8-B HEX ZINC	F81032-1	1
16	BOLT M8X45-8.8	F81002-17	1
17	SPACER 10.2/20-4.5	546938	2
18	SPACER 10.2/20-7	546939	2

2.38 Table 546819

546819_001_A
546819_MANUAL

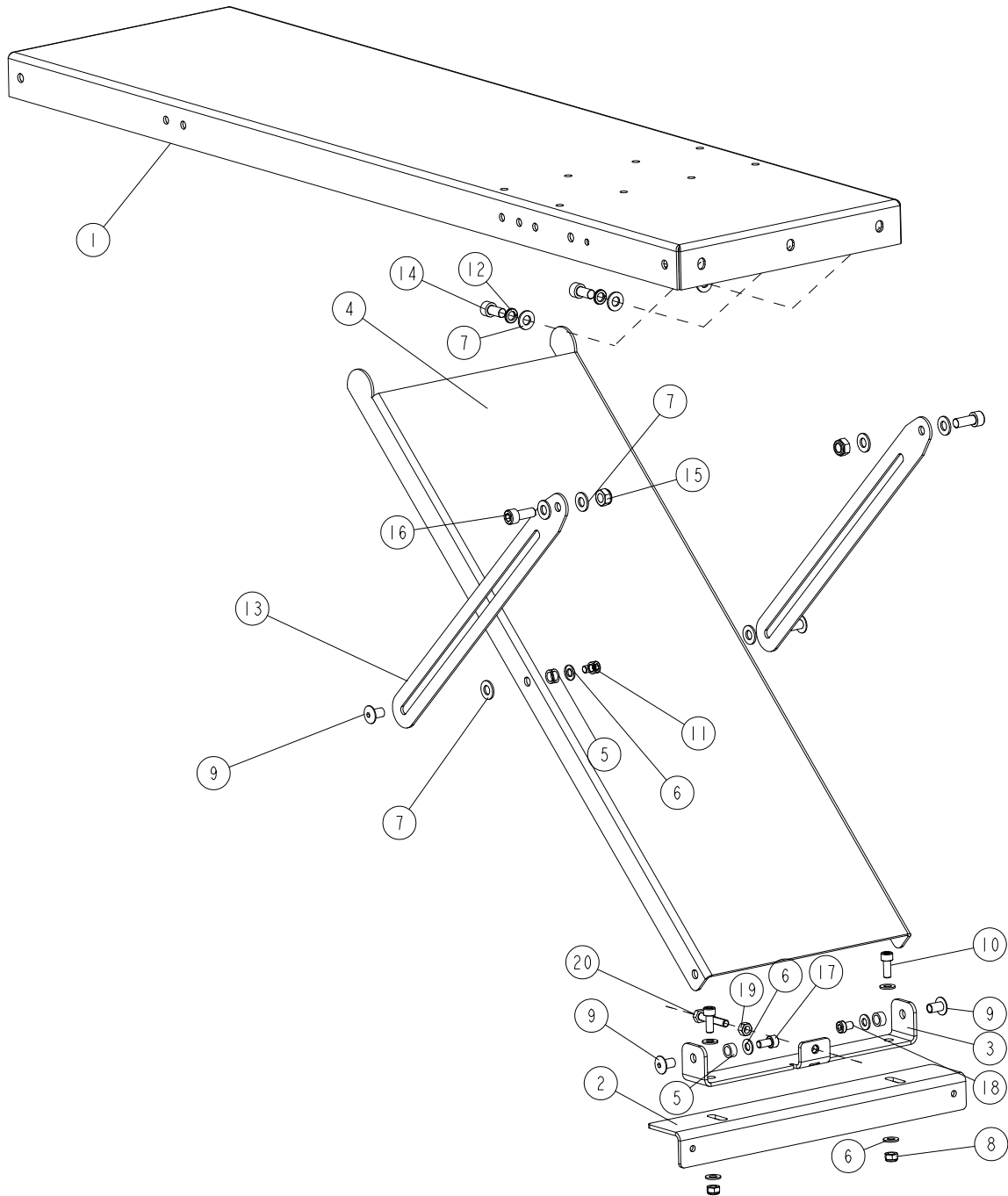

REF.	DESCRIPTION (* indicates parts available in assemblies only)	PART #	QTY
-	TABLE, MP200	546819	1
1	PLATE, TABLE 265	265-100-1	1
2	ANGLE SECTION	265-104-1	1
3	CHANNEL BAR, MP260 WELDMENT	541453-1	1
4	PLATE, TABLE SUPPORT 265-000	265-101-1	1

REF.	DESCRIPTION (* indicates parts available in assemblies only)	PART #	QTY	
5	BUSHING 10.3/15-7.5	533724	4	
6	WASHER 8.4 ZC DIN 126 ISO 7091 FLAT ZINC	F81054-1	8	
7	WASHER, 10.5 FLAT ZINC	F81055-1	9	
8	NUT, M8-8-B HEX NYLON ZINC LOCK	F81032-2	2	
9	NUT, ERICSON M8 AN88 COLLAR ZINC	F81032-33	4	
10	SCREW, M8X20-8.8 HEX SOCKET HEAD CAP ZINC	F81002-30	2	
11	SCREW, M8X10-8.8 HEX SOCKET HEAD CAP ZINC	F81002-32	2	
12	WASHER, Z 10.2 SPLIT LOCK ZINC	F81055-2	3	
13	SLIDER, TABLE	533728-1	2	
14	SCREW, M10X20 8.8 HEX SOCKET HEAD CAP ZINC	F81003-108	3	
15	NUT, M10-8-B HEX NYLON ZINC LOCK	F81033-1	2	
16	SCREW, M10X25 8.8 HEX SOCKET HEAD CAP ZINC	F81003-32	2	
17	SCREW, M8X16-8.8 HEX SOCKET HEAD CAP ZINC	F81002-39	1	
18	SCREW, M8X12 SOCKET HEAD/10.9	F81002-110	1	
19	NUT, M8-8-B DIN 934HEX ZINC	F81032-1	1	
20	BOLT, M8X45-8.8 HEX HEAD ZINC	F81002-17	1	

2.39 Side Clamp, MP200/MP220 (No. 564986) - additional equipment

564986_001
564986_MANUAL

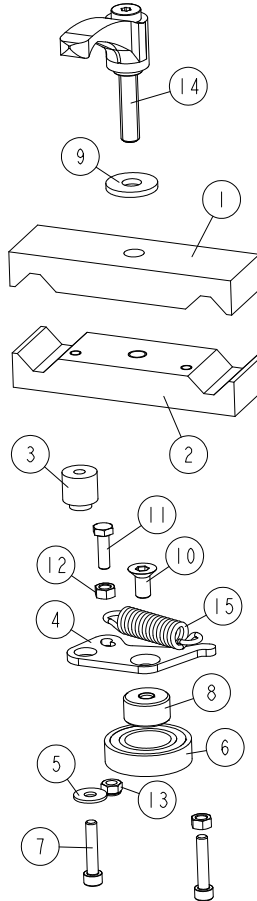

REF.	DESCRIPTION (* indicates parts available in assemblies only)	PART #	QTY
-	SIDE CLAMP, MP200/220	564986	1
1	PLATE, BASIC UPPER	533527-1	1
2	PLATE, BASIC LOWER	533526-1	1
3	BUSHING, 6.2/19-20.3 12-4.3	533528	1
4	BRACKET, BEARING MOVABLE	533525-1	1
5	WASHER, 6.5 SPECIAL FLAT ZINC	F81053-11	1
6	BEARING, 6005 2RS PN-85/M-86100	089652	1
7	SCREW, M6X30-8.8 HEX SOCKET HEAD CAP ZIN	F81001-42	2
8	BUSHING, M8/25-13.5 ZINC-PLATED	533529-1	1
9	WASHER, 10.5 SPECIAL FLAT ZINC	F81055-6	1
10	SCREW, M8X16-10.9 FE/ZN5 DIN7991 FLAT SO	F81002-82	1
11	BOLT, M6X20 8.8 HEX HEAD FULL THREAD ZIN	F81001-2	1
12	NUT, M6 8 HEX ZINC	F81031-1	2
13	NUT, M6-8-B HEX NYLON ZINC LOCK	F81031-2	1
14	HANDLE, ERZ.78 P-M10X40 ADJUSTABLE	533536	1
15	SPRING, 15X65X2.5 EXTENSION	533571	1

SECTION 3 MOTOR KITS MP220 CE

3.1 Motor Kits 545712

545712_001
545712_MANUAL

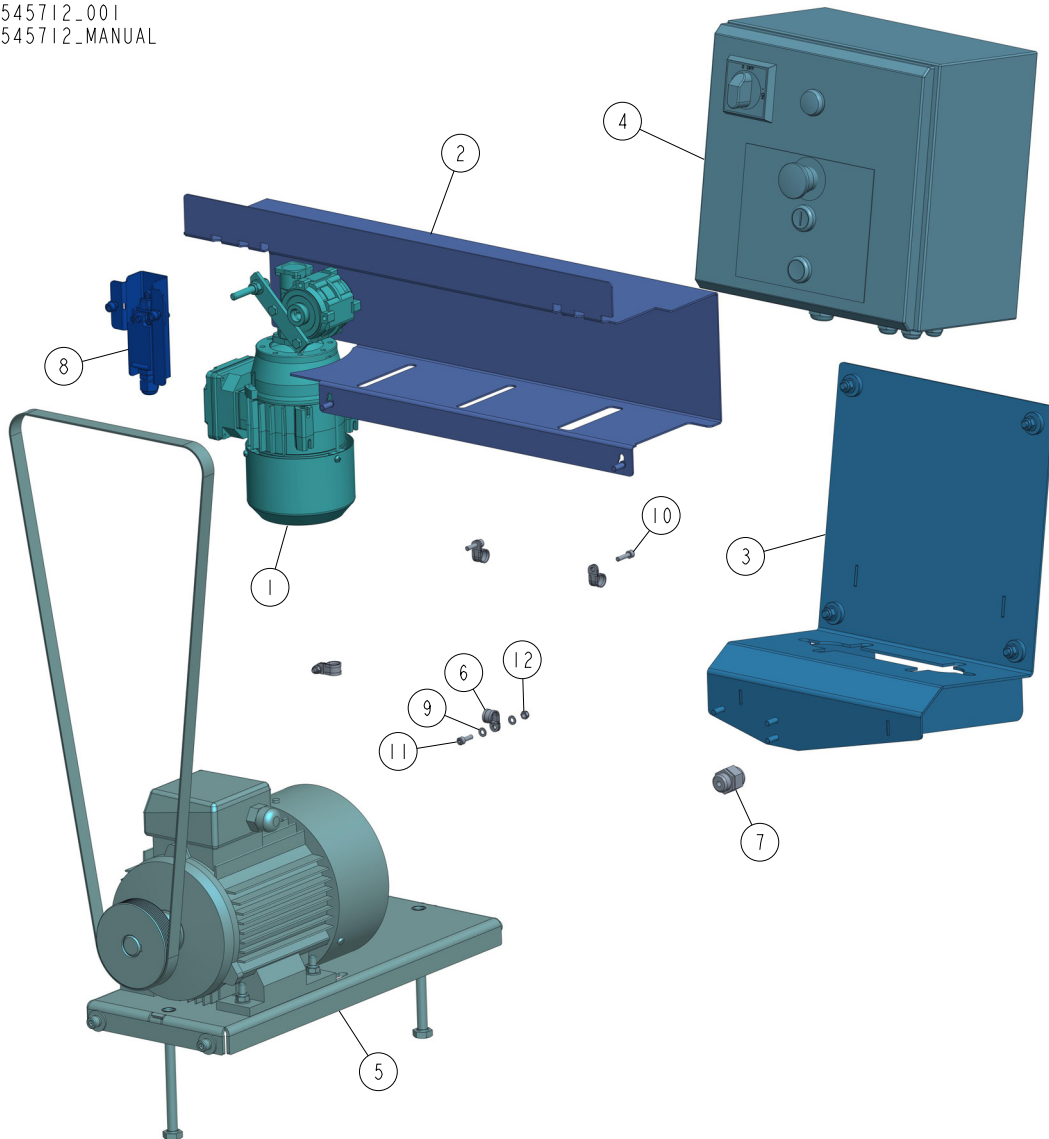

REF	DESCRIPTION (◆ indicates parts available in assemblies only)	PART #	QTY
-	MOTOR KIT, ECO MP220EH 3X400V CE	545712	1
-	MOTOR KIT, ECO MP220B 3x230V CE	545712-2	1
-	MOTOR KIT, ECO MP220A 1x230V CE	545712-6	1
-	MOTOR KIT, PRO MP220H 3x400V CE	545722	1
-	MOTOR KIT, PRO MP220B 3x230V CE	545722-2	1
1	DRIVE, MP200 ECO FEED See Section 3.2	533638	1
	DRIVE, MP200 ECO FEED See Section 3.4	533638-6 ¹	1
	DRIVE, PRO FEED See Section 3.6	533650 ²	1
2	GUARD, CHAIN - COMPLETE See Section 3.8	542488	1
3	BRACKET, ELECTRICAL BOX MOUNT - COMPLETE See Section 3.9	542487	1
4	BOX, MP220 ELECTRICAL - COMPLETE See Section 3.10	536949	1
	BOX, MP220B ELECTRICAL	536949-2 ³	1
	BOX, MP220A ELECTRICAL	536949-6 ⁴	1

REF	DESCRIPTION (◆ indicates parts available in assemblies only)	PART #	QTY	
	BOX, MP220H-V ELECTRICAL	545721 ⁵	1	
	BOX, MP220B-V ELECTRICAL	545721-2 ⁶	1	
5	DRIVE ASSEMBLY, CUTTER & BLADE See Section 3.11	542486	1	
	DRIVE ASSEMBLY, CUTTER & BLADE See Section 3.12	542486-6 ⁷	1	
	DRIVE ASSEMBLY, CUTTER & BLADE	546900 ⁸	1	
6	CLIP, RSGU 1.10/12W1 RETAINING	086861	4	
7	GLAND, DP 13/H CABLE	F81096-4	1	
8	SWITCH ASSEMBLY, LIMIT See Section 3.13	546848	1	
9	WASHER, 5.3 FLAT ZINC	F81052-1	6	
10	SCREW, M5X20 8.8 HEX SOCKET HEAD CAP ZIN	F81000-72	2	
11	SCREW, M5X16-8.8 HEX SOCKET HEAD CAP ZIN	F81000-25	2	
12	NUT, M5-8-FE/ZN5 DIN985	F81030-2	2	

¹ Included in 545712-6

² Included in PRO

³ Included in 545712-2

⁴ Included in 545712-6

⁵ Included in 545722

⁶ Included in 545722-2

⁷ Included in 545712-6

⁸ Included in PRO

3.2 ECO Feed Drive 533638

533638_001_B
533638_MANUAL

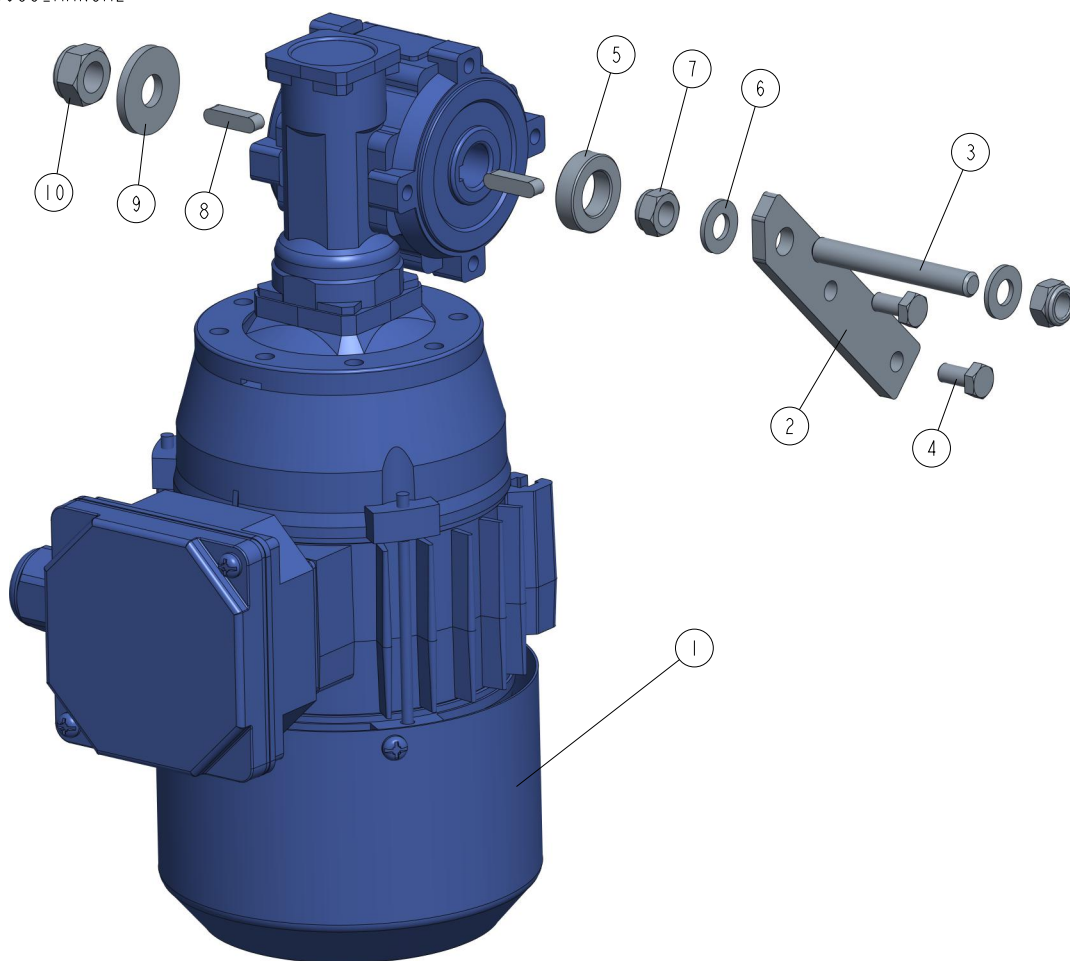

REF	DESCRIPTION (◆ indicates parts available in assemblies only)	PART #	QTY
-	DRIVE, MP200 ECO FEED	533638	1
1	MOTOREDUCER, KC30/P30+SKH63-4B2/X See Section 3.3	533639	1
2	ARM, TORQUE	533634-1	1
3	BOLT, M8	533635-1	1
4	BOLT M6X12 HH ZC FT 8.8 DIN 933	F81001-7	2
5	BUSHING, 14.3/25-7 ZINC-PLATED	533636-1	1
6	WASHER, 8.4 FLAT ZINC	F81054-1	2
7	NUT, M8 8 HEX NYLON ZINC LOCK	F81032-2	2
8	KEY, A5X5X20 PARALLEL	513320	2
9	WASHER, 10.5 SPECIAL FLAT ZINC	F81055-6	1
10	NUT, M10-8-B HEX NYLON ZINC LOCK	F81033-1	1

3.3 Motoreducer 533639

533639_001
533639

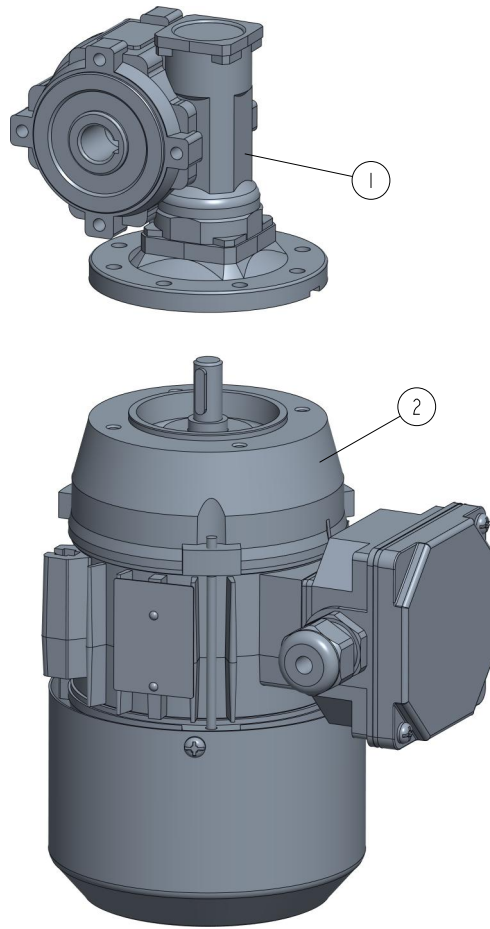

REF	DESCRIPTION (◆ indicates parts available in assemblies only)	PART #	QTY
-	MOTOREDUCER, KC30/P30+SKH63-4B2/X	533639	1
1	REDUCER, KC30/P30 90/11 V6	533637	1
2	MOTOR, SKH63-4B2 (0.18KW; 1370 R.P.M.)	532802	1

3.4 ECO Feed Drive 533638-6

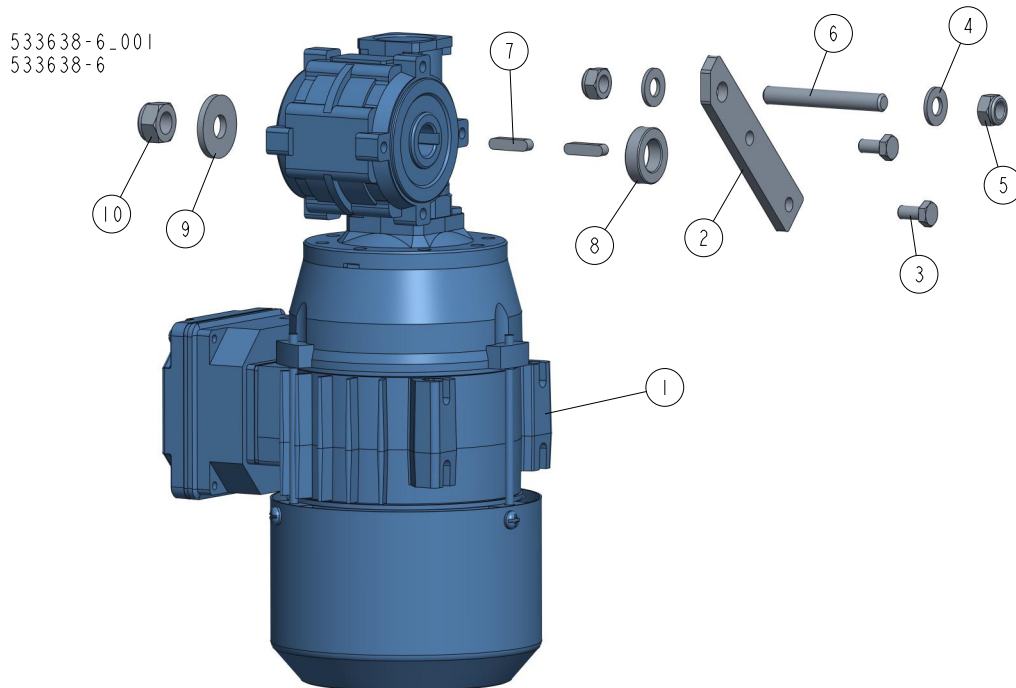

REF	DESCRIPTION (◆ indicates parts available in assemblies only)	PART #	QTY
-	DRIVE, MP200 ECO FEED	533638-6	1
1	MOTOREDUCER KC30/P30+SEMKH634C2/X See Section 3.5	533654	1
2	ARM, TORQUE	533634-1	1
3	BOLT M6X12 8.8 FE/ZN5 PN-85/M-82105	F81001-7	2
4	WASHER, 8,4-FLAT ZINC	F81054-1	2
5	NUT, M8-8-B HEX NYLON ZINC LOCK	F81032-2	2
6	BOLT, M8	533635-1	1
7	KEY, A5X5X20 PARALLEL	513320	2
8	BUSHING, 14.3/25-7 ZINC-PLATED	533636-1	1
9	WASHER, 10.5 ZINC FLAT SPECIAL	F81055-6	1
10	NUT, M10-8-B NYLON HEX ZINC LOCK	F81033-1	1

3.5 Motoreducer 533654

533654_001
533654

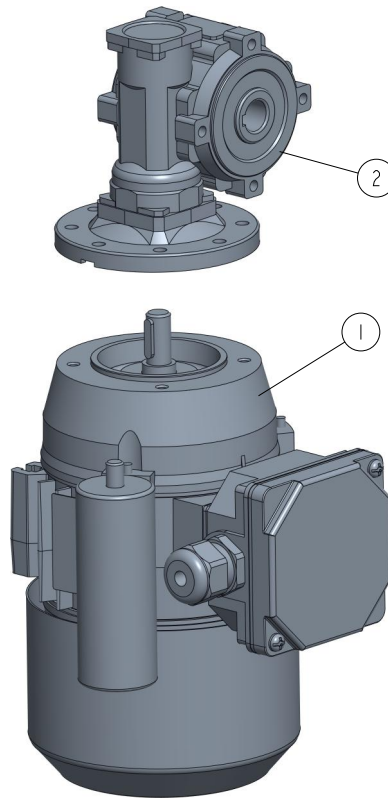

REF	DESCRIPTION (◆ indicates parts available in assemblies only)	PART #	QTY	
-	MOTOREDUCER KC30/P30+SEMKh634C2/X	533654	1	
1	MOTOR SEMKH 63-4C2/X 0.18KW	533656	1	
2	REDUCER, KC30/P30 90/11 V6	533637	1	

3.6 PRO Feed Drive 533650

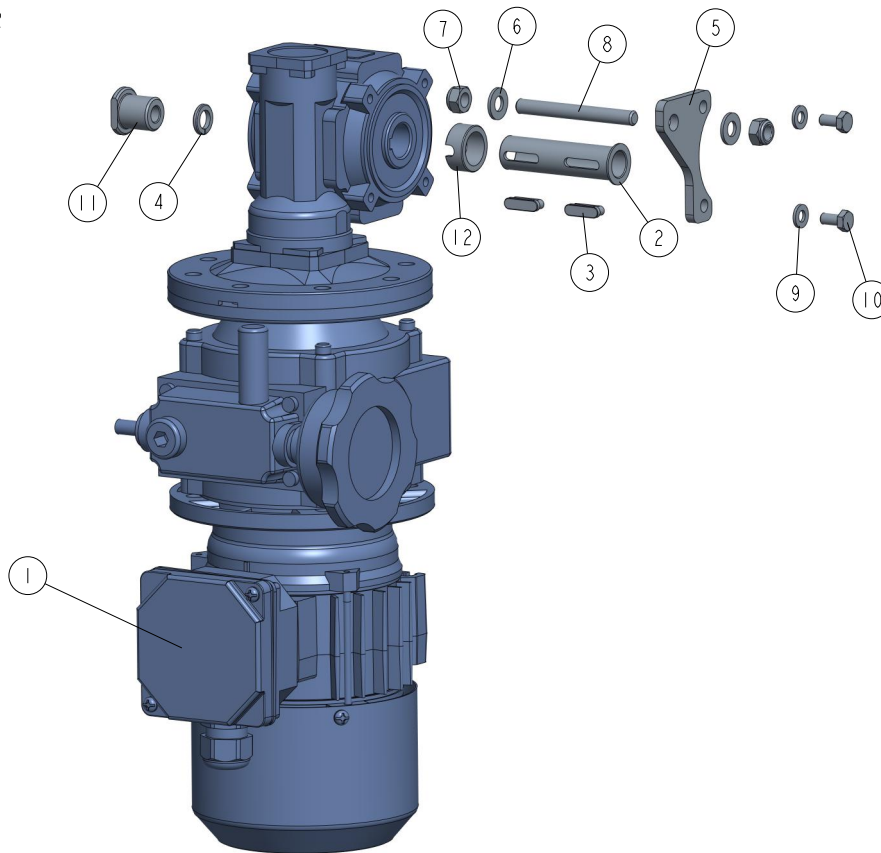
533650_002
533650

REF	DESCRIPTION (◆ indicates parts available in assemblies only)	PART #	QTY
-	DRIVE, PRO FEED	533650	1
1	REDUCER, PRO KC40/P15+NF003+SKH63-2C See Section 3.7	533640	1
2	BUSHING, REDUCER	533731	1
3	KEY	533732	2
4	WASHER, 10.2 SPLIT LOCK ZINC	F81055-2	1
5	ARM, TORQUE	533734-1	1
6	WASHER, 8.4 ZINC FLAT	F81054-1	2
7	NUT, M8-8-B HEX NYLON ZINC LOCK	F81032-2	2
8	BOLT, M8	533635-1-6U	1
9	WASHER, 6.4 FLAT ZINC	F81053-1	2
10	BOLT, M6X12-8.8 HEX HEAD FULL THREAD ZIN	F81001-7	2
11	NUT, M10	533733-1-6U	1
12	BUSHING, REDUCER	541449	1

3.7 Reducer 533640

533640_001
533640

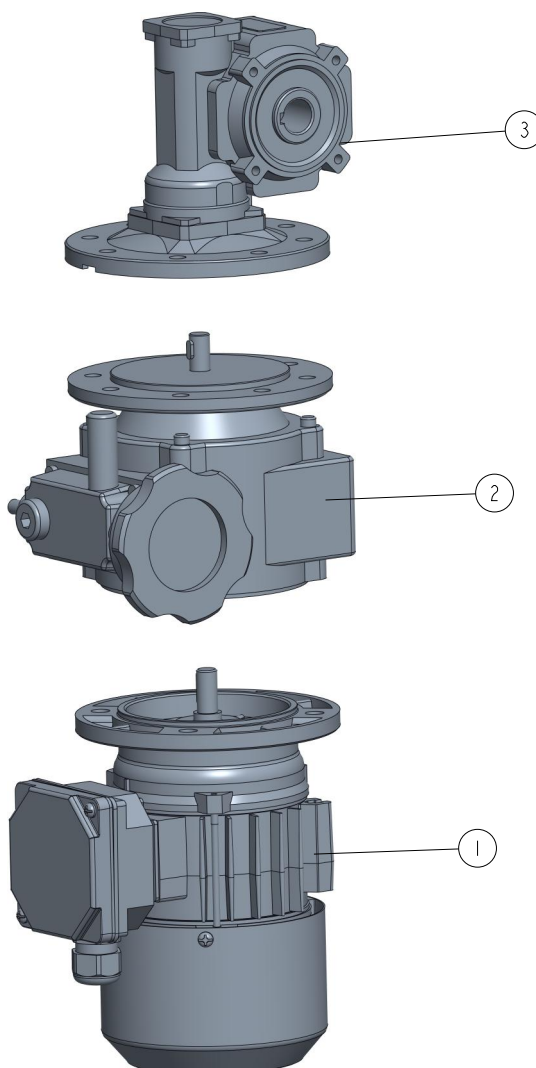

REF	DESCRIPTION (◆ indicates parts available in assemblies only)	PART #	QTY	
-	REDUCER, PRO KC40/P15+NF003+SKH63-2C	533640	1	
1	MOTOR SKH63-B (0.37 KW; 2800 REV/MIN)	533642	1	
2	SPEED VARIATOR NF003 140/11 V3	533643	1	
3	REDUCER KC40 P15 63 B5 V6 H18 3D	533641	1	

3.8 Chain Guard 542488

542488_001
542488

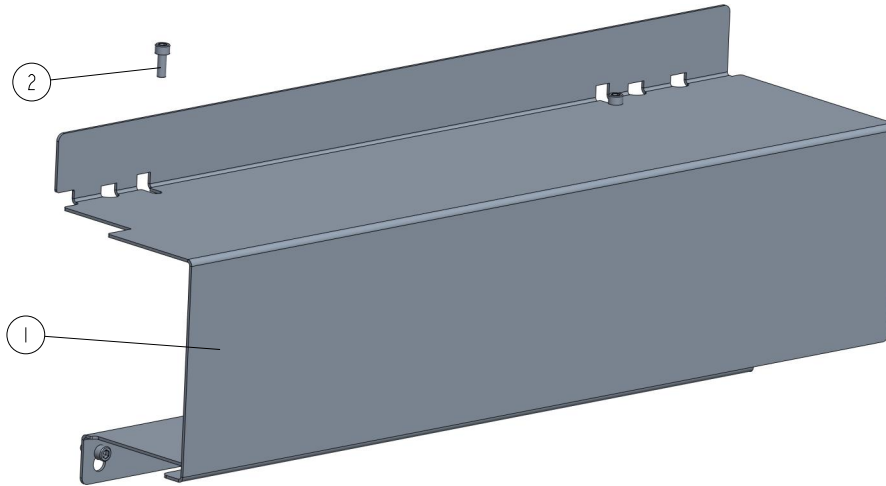

REF	DESCRIPTION (◆ indicates parts available in assemblies only)	PART #	QTY	
-	GUARD, CHAIN - COMPLETE	542488	1	
1	GUARD, CHAIN	546622-1	1	
2	SCREW, M6X16-8.8 HEX SOCKET HEAD CAP ZIN	F81001-21	4	

3.9 Electrical Box Mount Bracket 542487

542487_001
542487_MANUAL

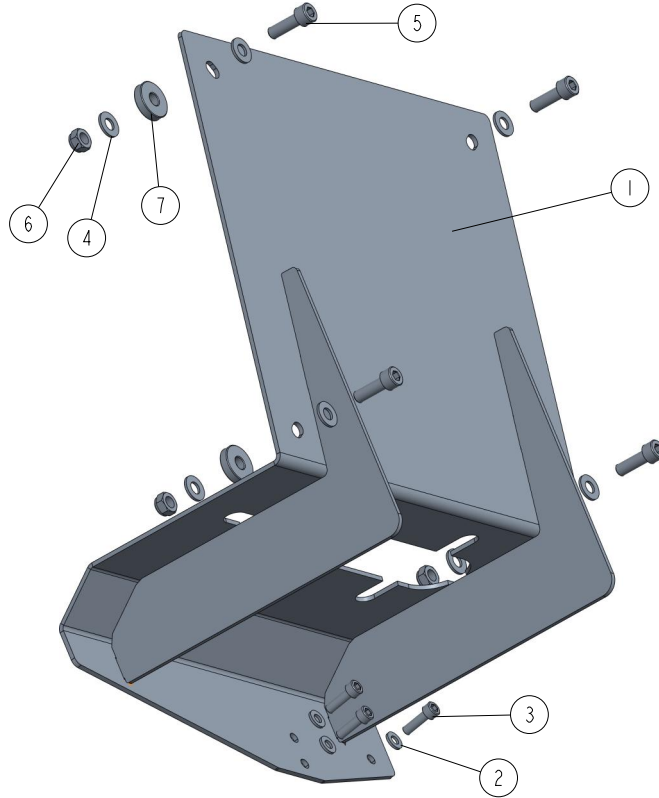

REF.	DESCRIPTION (* indicates parts available in assemblies only)	PART #	QTY
-	BRACKET, ELECTRICAL BOX MOUNT - COMPLETE	542487	1
1	BRACKET ASSEMBLY, ELECTRICAL BOX MOUNT	546248-1	1
2	WASHER, 6.4 FLAT ZINC	F81053-1	3
3	SCREW, M6X20 8.8 HEX SOCKET HEAD CAP ZINC	F81001-22	3
4	WASHER, 8.4 FLAT ZINC	F81054-1	8
5	SCREW, M8X25 -8.8 HEX SOCKET HEAD CAP ZINC	F81002-21	4
6	NUT, M8-8-B HEX NYLON ZINC LOCK	F81032-2	4
7	WASHER, 8.5/25-6 POLYAMIDE	523952	4

3.10 Electrical Box 536949

536949_001
536949_MANUAL

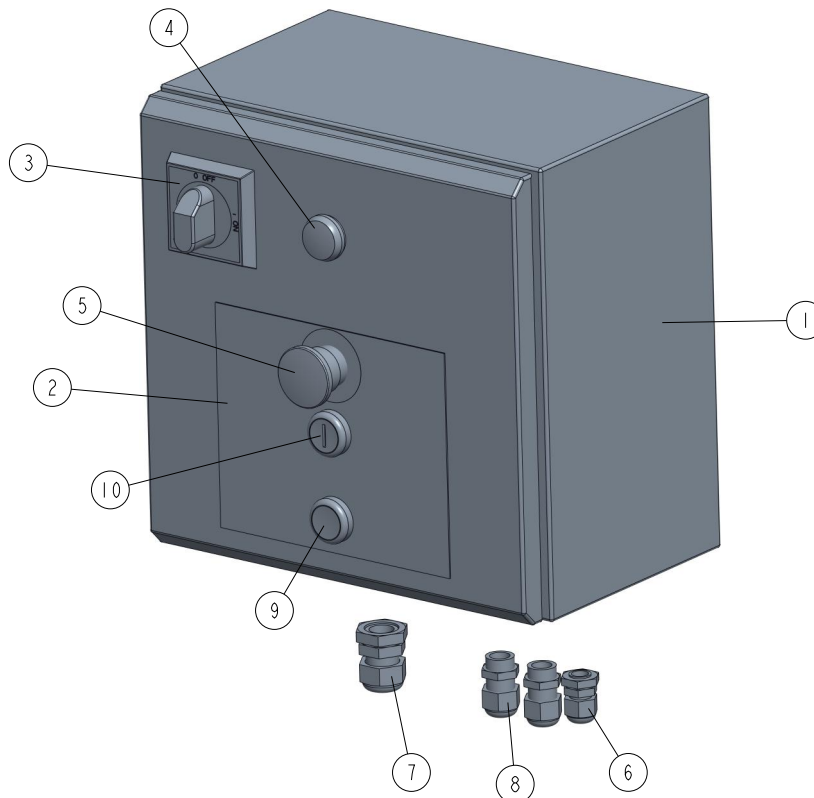

REF.	DESCRIPTION (* indicates parts available in assemblies only)	PART #	QTY
-	BOX, MP220 ELECTRICAL - COMPLETE	536949	1
1	BOX, ELECTRICAL	534763	1
2	DECAL, ELECTRICAL BOX	534765	1
3	HANDLE, ABB SWITCH	088265-1	1
4	LIGHT, M22 LED 24V BLUE CONTROL	090448	1
5	SWITCH, XB4 BS542 EMERGENCY STOP	086556	1
6	GLAND, DP9/H CABLE	F81096-2	1
7	GLAND, DP16/H CABLE	F81096-7	1
8	GLAND, DW11/H CABLE	085388	2
9	BUTTON, LPCB2102 - COMPLETE	535437-K	1
10	BUTTON, LPCBL1117 - COMPLETE	535441-K	1

3.11 Cutter & Blade Drive Assembly 542486

542486_001_B
542486_MANUAL

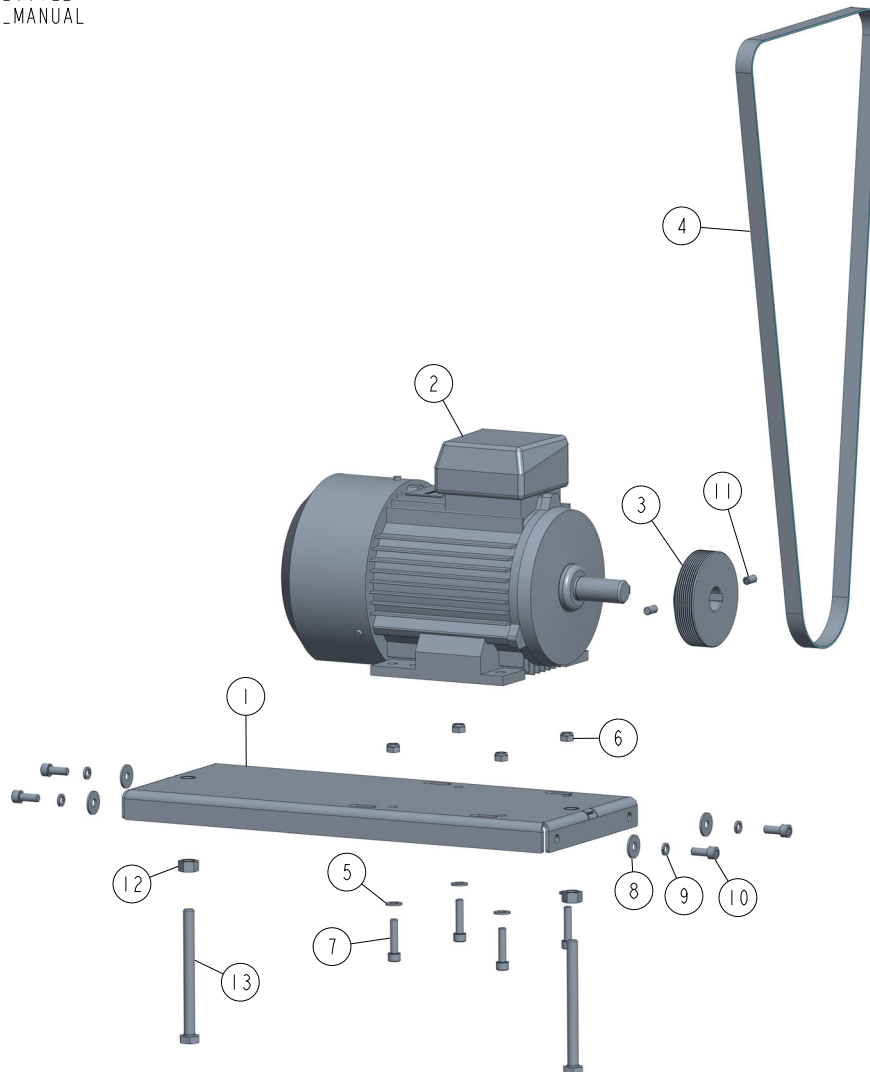

REF	DESCRIPTION (◆ indicates parts available in assemblies only)	PART #	QTY
-	DRIVE ASSEMBLY, CUTTER & BLADE	542486	1
1	MOTOR PLATE WELDED / PAINT	534200-1	1
2	MOTOR 3SIE90L2A, 3KW, 2900 R.P.M, 50HZ	537386	1
3	PULLEY, MULTI-GROOVE ALUMINIUM	533585	1
4	BELT, 8 PJ 1600 RIBBED	546621	1
5	WASHER, 8.4 FLAT ZINC	F81054-1	8
6	NUT, M8-8-B HEX NYLON ZINC LOCK	F81032-2	4
7	SCREW M8X35 SHCS ZC 8.8 DIN 912 ISO 476	F81002-58	4
8	WASHER, 8.5 SPECIAL FLAT ZINC	F81054-11	4
9	WASHER, 8.2 SPLIT LOCK	F81054-4	4
10	BOLT, M8 X 20-8.8 SOCKET HEAD	F81002-30	4
11	SCREW M8X16 HSS W/FLAT POINT ZC 45H DIN	F81002-124	2
12	NUT, M12-8 ZINC	F81034-1	2
13	BOLT, M12X130-8.8 HEX HEAD FULL THREAD Z	F81004-55	2

3.12 Cutter & Blade Drive Assembly 542486-6

542486_001_B
542486_MANUAL

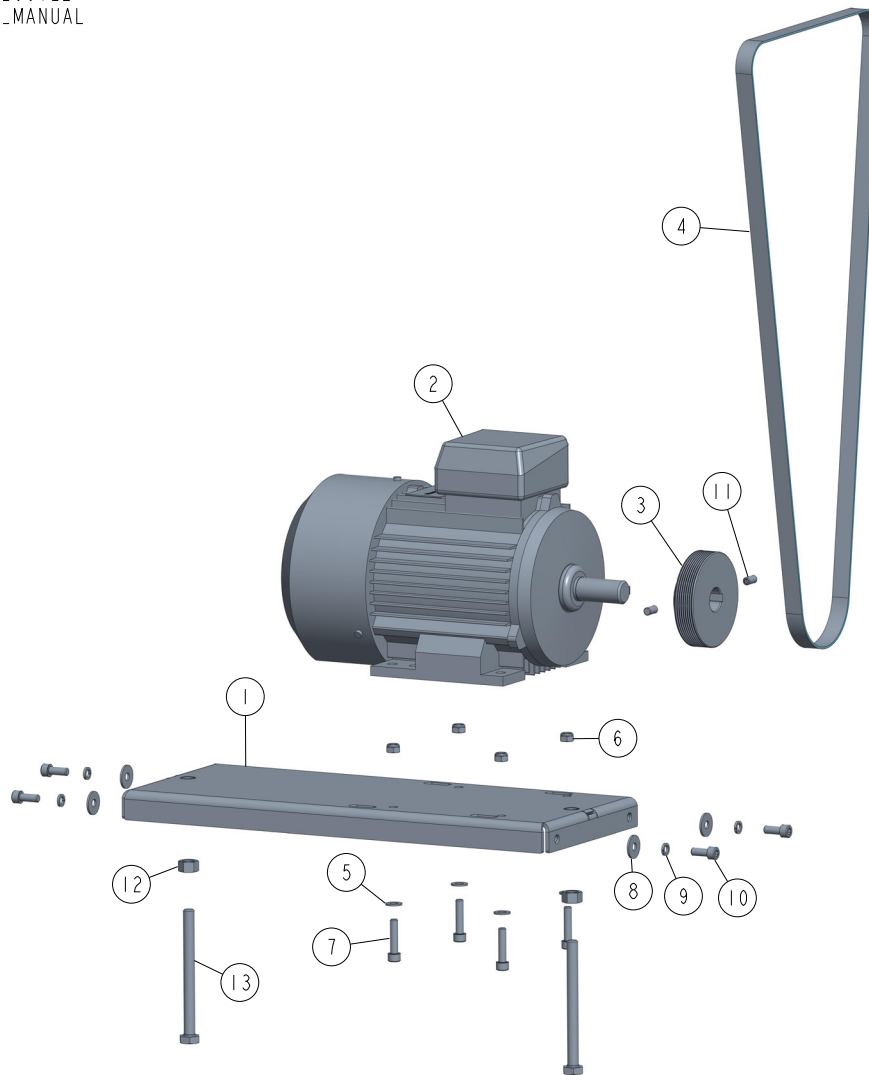

REF	DESCRIPTION (◆ indicates parts available in assemblies only)	PART #	QTY
-	DRIVE ASSEMBLY, CUTTER & BLADE	542486-6	1
1	MOTOR PLATE WELDED / PAINT	534200-1	1
2	MOTOR SELHR90-2M2 IMB34/2 2,7KW 230V 4,	533651	1
3	PULLEY, MULTI-GROOVE ALUMINIUM	533585	1
4	BELT, 8 PJ 1600 RIBBED	546621	1
5	WASHER, 8.4 FLAT ZINC	F81054-1	8
6	NUT, M8-8-B HEX NYLON ZINC LOCK	F81032-2	4
7	SCREW, M8X30-8.8 HEX SOCKET HEAD CAP ZIN	F81002-31	4
8	WASHER, 8.5 SPECIAL FLAT ZINC	F81054-11	4
9	WASHER, 8.2 SPLIT LOCK	F81054-4	4
10	BOLT, M8 X 20-8.8 SOCKET HEAD	F81002-30	4
11	SCREW M8X16 HSS W/FLAT POINT ZC 45H DIN	F81002-124	2
12	NUT, M12-8 ZINC	F81034-1	2
13	BOLT, M12X130-8.8 HEX HEAD FULL THREAD Z	F81004-55	2

3.13 Limit Switch Assembly 546848

546848_001
546848

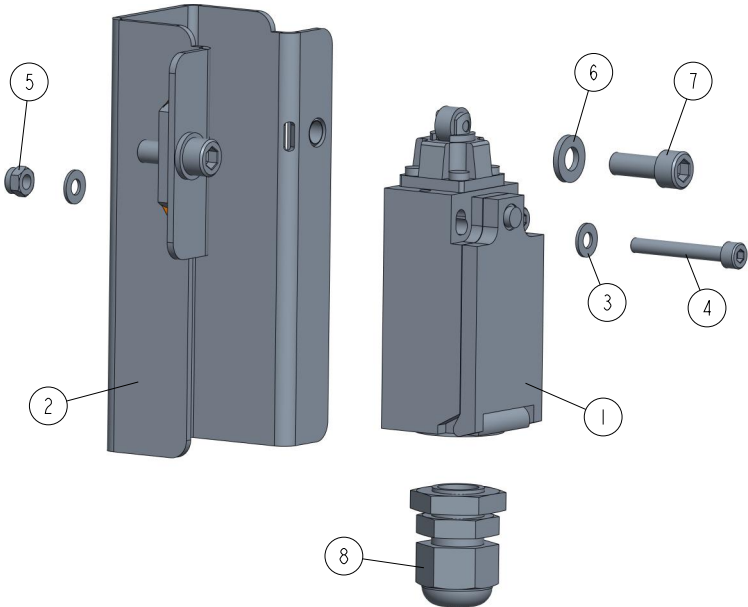

REF	DESCRIPTION (◆ indicates parts available in assemblies only)	PART #	QTY
-	SWITCH ASSEMBLY, LIMIT	546848	1
1	SAFETY SWITCH D4N-4132	537641	1
2	GUARD, LIMIT SWITCH	546847-1	1
3	WASHER, 4.3 FLAT ZINC	F81051-2	4
4	SCREW, M4X30-8.8 HEX SOCKET HEAD CAP ZIN	F81000-85	2
5	NUT, M4-B HEX NYLON ZINC LOCK	F81029-1	2
6	WASHER, 6.4 ZINC FLAT	F81053-1	2
7	SCREW, M6X16-8.8 HEX SOCKET HEAD CAP ZIN	F81001-21	2
8	GLAND, DP 9/H CABLE	F81096-2	1

SECTION 4 MOTOR KITS MP220 UL AMERICAN VERSION

4.1 Motor Kit 545722-2U

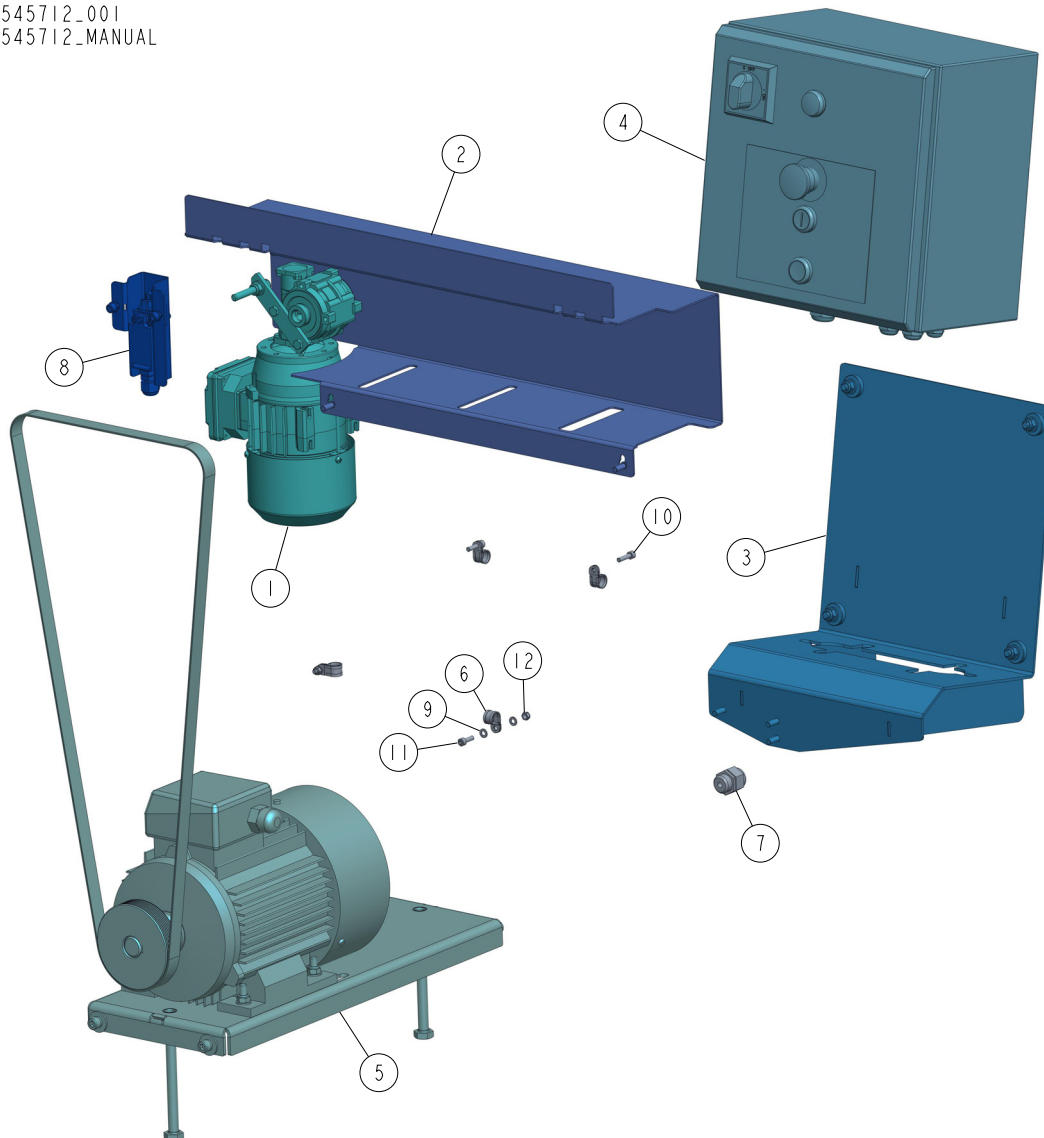
545712_001
545712_MANUAL

REF	DESCRIPTION (◆ indicates parts available in assemblies only)	PART #	QTY
-	MOTOR KIT, PRO MP220B PRO 3x230V UL	545722-2U	1
1	DRIVE, MP220 UL FEED See Section 4.3	533650-U	1
2	GUARD, CHAIN - COMPLETE See Section 3.8	542488	1
3	BRACKET, ELECTRICAL BOX MOUNT - COMPLETE See Section 3.9	542487	1
4	BOX, MP220B-V UL ELECTRICAL - COMPLETE	545721-2U	1
5	DRIVE, CUTTER & BLADE 4KW See Section 4.7	546900-2U	1
6	CLIP, RSGU 1.10/12W1 RETAINING	086861	4
7	GLAND, DP 13/H CABLE	F81096-4	1
8	SWITCH ASSEMBLY, LIMIT See Section 3.13	546848	1
9	WASHER, 5.3 FLAT ZINC	F81052-1	6
10	SCREW, M5X20 8.8 HEX SOCKET HEAD CAP ZIN	F81000-72	2
11	SCREW, M5X16-8.8 HEX SOCKET HEAD CAP ZIN	F81000-25	2
12	NUT, M5-8-FE/ZN5 DIN985	F81030-2	2

4.2 Motor Kit 545722-6U

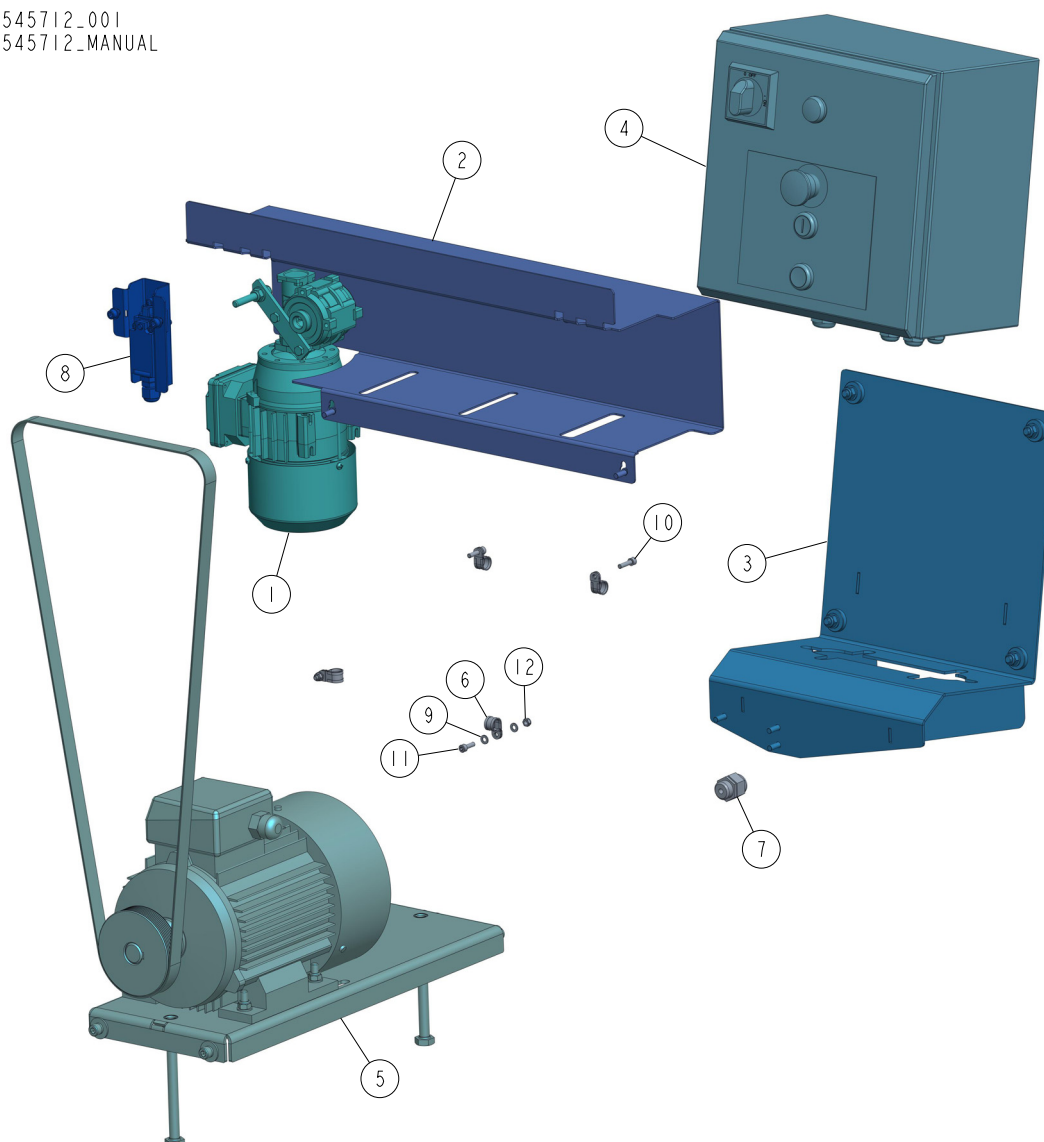
545712_001
545712_MANUAL

REF	DESCRIPTION (◆ indicates parts available in assemblies only)	PART #	QTY
-	MOTOR KIT, PRO MP220EA 1x230V UL	545722-6U	1
1	DRIVE, MP220 UL FEED See Section 4.5	533650-6U	1
2	GUARD, CHAIN - COMPLETE See Section 3.8	542488	1
3	BRACKET, ELECTRICAL BOX MOUNT - COMPLETE See Section 3.9	542487	1
4	BOX, MP220B-V UL ELECTRICAL - COMPLETE	545721-6U	1
5	DRIVE, CUTTER & BLADE 4KW See Section 4.8	546900-6U	1
6	CLIP, RSGU 1.10/12W1 RETAINING	086861	4
7	GLAND, DP 13/H CABLE	F81096-4	1
8	SWITCH ASSEMBLY, LIMIT See Section 3.13	546848	1
9	WASHER, 5.3 FLAT ZINC	F81052-1	6
10	SCREW, M5X20 8.8 HEX SOCKET HEAD CAP ZIN	F81000-72	2
11	SCREW, M5X16-8.8 HEX SOCKET HEAD CAP ZIN	F81000-25	2
12	NUT, M5-8-FE/ZN5 DIN985	F81030-2	2

4.3 PRO Feed Drive 533650-U

533650_002
533650

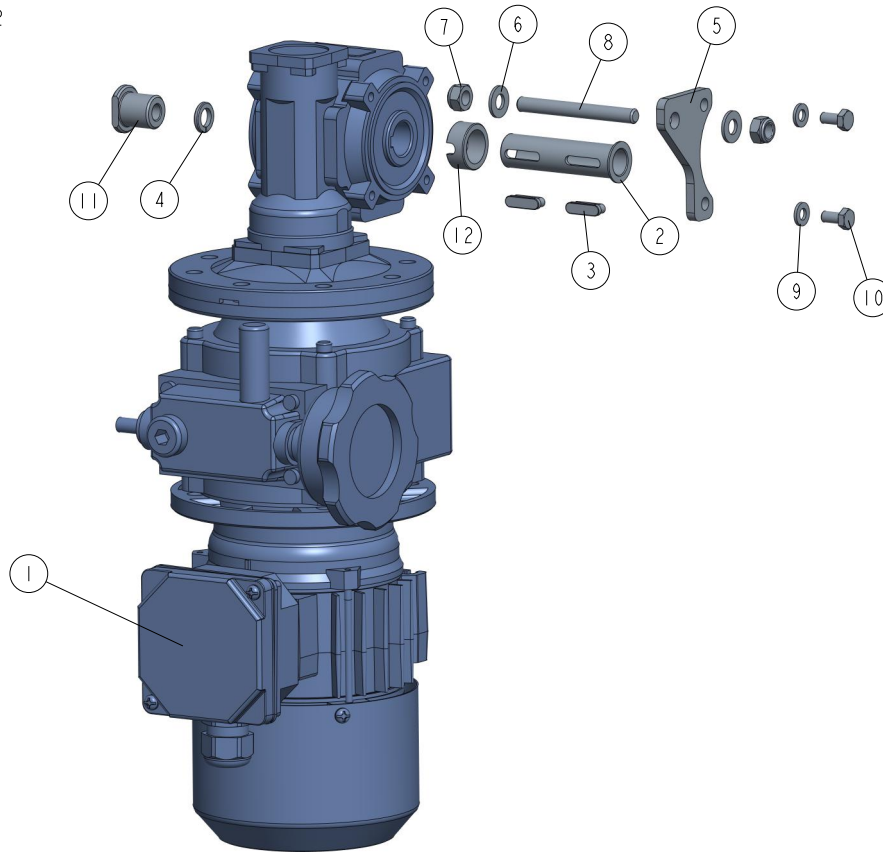

REF	DESCRIPTION (◆ indicates parts available in assemblies only)	PART #	QTY
-	DRIVE, PRO FEED	533650-U	1
1	MOTOREDUCER KC40/P 15+ NF003 + SKH63-2 See Section 4.4	533640-UL	1
2	BUSHING, REDUCER	533731	1
3	KEY	533732	2
4	WASHER, 10.2 SPLIT LOCK ZINC	F81055-2	1
5	ARM, TORQUE	533734-1	1
6	WASHER, 8.4 ZINC FLAT	F81054-1	2
7	NUT, M8-8-B HEX NYLON ZINC LOCK	F81032-2	2
8	BOLT, M8	533635-1-6U	1
9	WASHER, 6.4 FLAT ZINC	F81053-1	2
10	BOLT, M6X12-8.8 HEX HEAD FULL THREAD ZIN	F81001-7	2
11	NUT, M10	533733-1-6U	1
12	BUSHING, REDUCER	541449	1

4.4 Motoreducer 533640-UL

533640_001
533640

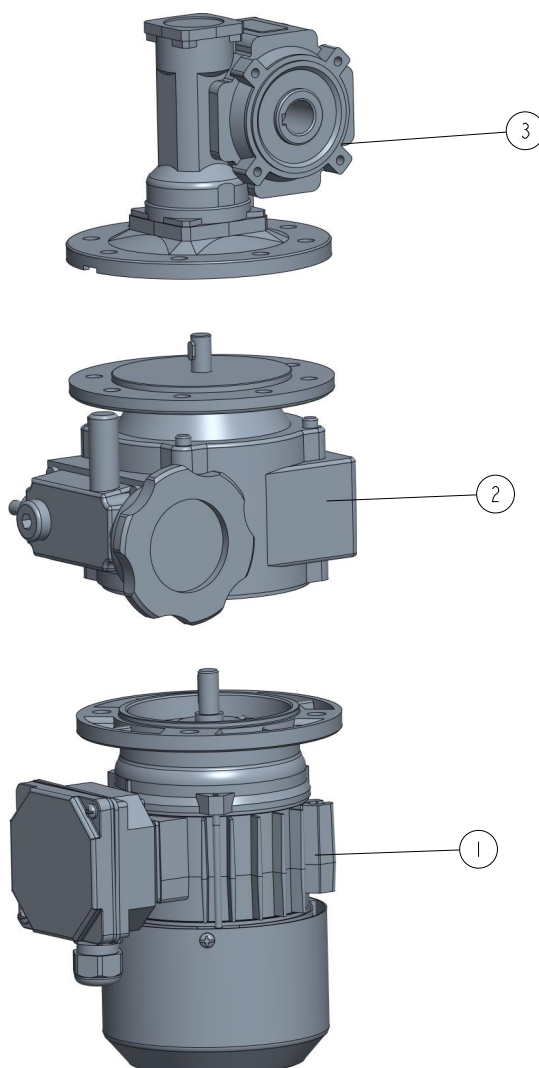

REF	DESCRIPTION (◆ indicates parts available in assemblies only)	PART #	QTY	
-	MOTOREDUCER 2SIEK6-2C UL/CSA + NF003 + KC40/P	533640-UL	1	
1	MOTOR, SKH63-2C2/x UL	533642-UL	1	
2	SPEED VARIATOR NF003 140/11 V3	533643	1	
3	REDUCER KC40 P15 63 B5 V6 H18 3D	533641	1	

4.5 PRO Feed Drive 533650-6U

533650-6U_001
533650-6U_MANUAL

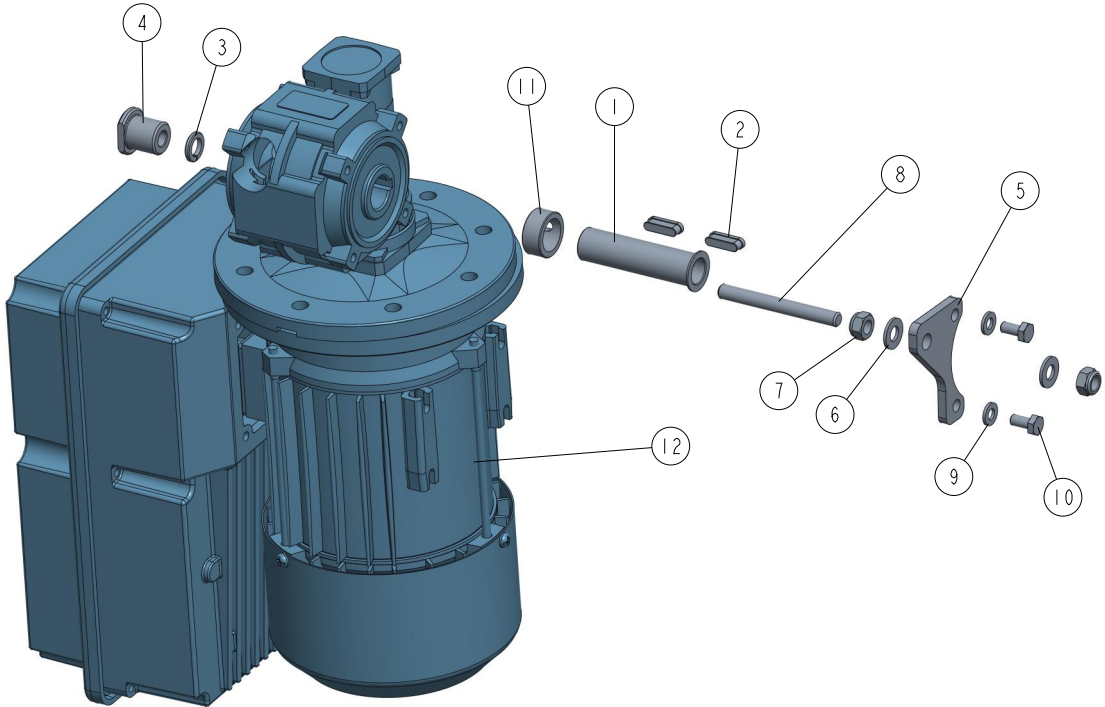

REF	DESCRIPTION (◆ indicates parts available in assemblies only)	PART #	QTY
-	PRO FEED DRIVE	533650-6U	1
1	BUSHING, REDUCER	533731	1
2	KEY	533732	2
3	WASHER, Z 10.2 SPLIT LOCK ZINC	F81055-2	1
4	NUT, M10	533733-1-6U	1
5	ARM, TORQUE	533734-1	1
6	WASHER, 8.4 FLAT,ZINC	F81054-1	2
7	NUT, M8-8-B HEX NYLON ZINC LOCK	F81032-2	2
8	BOLT, M8	533635-1-6U	1
9	WASHER, 6.4 FLAT ZINC	F81053-1	2
10	BOLT, M6X12-8.8 HEX HEAD FULL THREAD ZIN	F81001-7	2
11	BUSHING, REDUCER	541449	1
12	UP/DOWN DRIVE See Section 4.6	597559	1

4.6 Up/Down Drive 597559

597559_001
597559

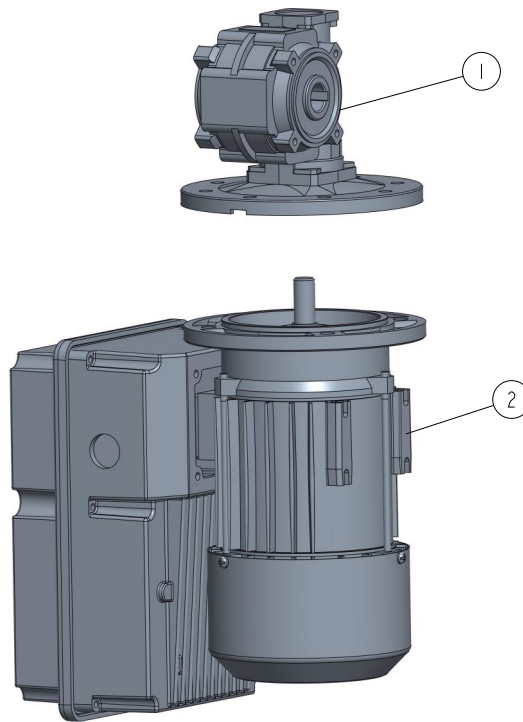

REF	DESCRIPTION (◆ indicates parts available in assemblies only)	PART #	QTY	
-	UP/DOWN DRIVE	597559	1	
1	REDUCER KC40/P15 160/14 V6 H18	535749	1	
2	MOTOR, 2SIEK71X-4C/T	592832	1	

4.7 Cutter & Blade Drive Assembly 546900-2U

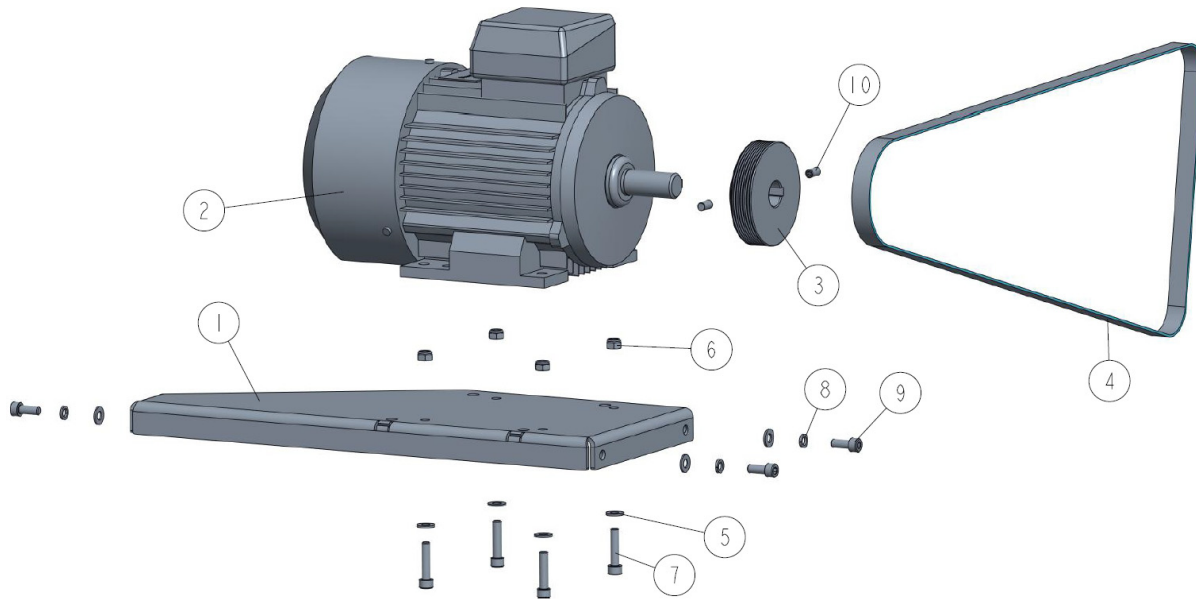
542486_001_B
542486_MANUAL

REF.	DESCRIPTION (* indicates parts available in assemblies only)	PART #	QTY
-	DRIVE ASSEMBLY, CUTTER & BLADE	546900-2U	1
1	PLATE WELDMENT, MOTOR MOUNT	533565-1	1
2	MOTOR, INDUKTA 3SIE100L2A 4KW IMB3 UL	537387-UL	1
3	PULLEY, MULTI-GROOVE ALUMINIUM	533585-P	1
4	BELT, 8 PJ 1600 RIBBED	546621	1
5	WASHER, 8.4 FLAT ZINC	F81054-1	11
6	NUT, M8-8-B HEX NYLON ZINC LOCK	F81032-2	4
7	SCREW M8X30 SHCS ZC 8.8 DIN 912 ISO 4762	F81002-31	4
8	WASHER, 8.2 SPLIT LOCK ZINC	F81054-4	3
9	SCREW, M8X20-8.8 HEX SOCKET HEAD CAP ZINC	F81002-30	3
10	SCREW M8X16 HSS W/FLAT POINT ZC 45H DIN	F81002-124	2

4.8 Cutter & Blade Drive Assembly 546900-6U

542486_001_B
542486_MANUAL

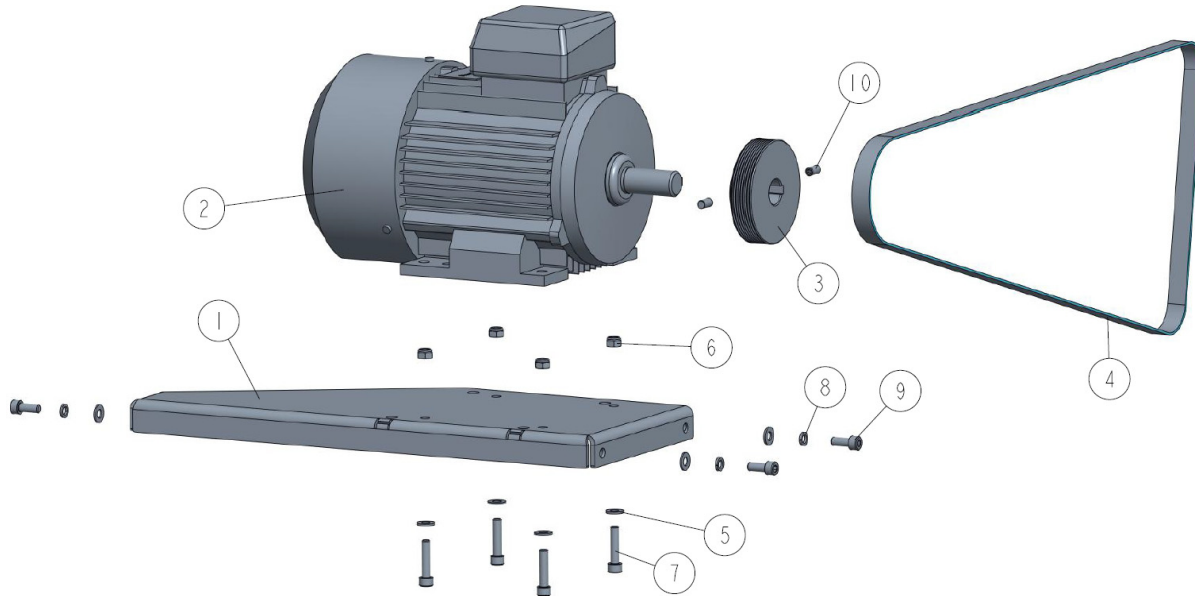

REF.	DESCRIPTION (* indicates parts available in assemblies only)	PART #	QTY
-	DRIVE ASSEMBLY, CUTTER & BLADE	546900-6U	1
1	PLATE WELDMENT, MOTOR MOUNT	533565-1	1
2	MOTOR SELHR90-2M2 IMB34/2 2,7KW 230V	533651-UL	1
3	PULLEY, MULTI-GROOVE ALUMINIUM	533585-P	1
4	BELT, 8 PJ 1600 RIBBED	546621	1
5	WASHER, 8.4 FLAT ZINC	F81054-1	11
6	NUT, M8-8-B HEX NYLON ZINC LOCK	F81032-2	4
7	SCREW M8X30 SHCS ZC 8.8 DIN 912 ISO 4762	F81002-31	4
8	WASHER, 8.2 SPLIT LOCK ZINC	F81054-4	3
9	SCREW, M8X20-8.8 HEX SOCKET HEAD CAP ZINC	F81002-30	3
10	SCREW M8X16 HSS W/FLAT POINT ZC 45H DIN	F81002-124	2