

user manual

Instrukcja obsługi | Руководство пользователя
Manuel de l'Utilisateur | Betriebsanweisung
Bruksanvisning | Manual del Usuario
Betjeningsvejledning | Gebruikershandleiding
Käyttöohjeet | Manual de utilizare | Bruksanvisning
Manuale d'uso | Příručka uživatele | Navodila
za uporabo

Retain for future use
Zachować do przyszłego użytku
Сохраните для последующего
использования
A conserver pour une utilisation future
Für zukünftige Benutzung aufbewahren
Behold for senere bruk
Säilytä nämä käyttöohjeet tulevaa tarvetta marten
Opbevar manualen til fremtidig brug
Bewaren voor gebruik in de toekomst
Conservare il presente manuale a l'uso futuro
Păstrați acest manual pentru utilizare viitoare
Conservar para futuras consultas
Behall för framtida användning
Uchovejte pro další použití
Hranite za prihodnjo uporabo

Wood-Mizer®

Safety, Setup, Operation and Maintenance

MP220 E3S

rev. A1.08

MP220 E4S-V

rev. A1.08



Safety is our #1 concern! Read and understand all safety information and instructions before operating, setting up or maintaining this machine.

Form #2465

Table of Content

Section-Page

SECTION 1	INTRODUCTION	1-1
1.1	Machine description	1-2
1.2	Planer/moulder major components	1-6
SECTION 2	SAFETY	2-1
2.1	Safety Symbols.....	2-1
2.2	Safety Instructions	2-1
SECTION 3	SETUP & OPERATION	3-1
3.1	Planer/moulder setup	3-1
3.2	MP220 planer/moulder operation.....	3-5
SECTION 4	MAINTENANCE	4-1
4.1	Wear life	4-1
4.2	Sawdust Removal	4-1
4.3	Miscellaneous Maintenance	4-1
4.4	Drive Belt Tension Adjustment.....	4-3
4.5	Long-term storage	4-6
4.6	Replacement of Inserts in Helical Cutterhead.....	4-7
4.7	Safety Devices Inspection	4-8
SECTION 5	PLANER/MOULDER SPECIFICATIONS	5-1
5.1	Overall dimensions.....	5-1
5.2	Specifications of the planer/moulder.....	5-2

SECTION 1 INTRODUCTION

Congratulations on your purchase of a Wood-Mizer Planer - Moulder!

Wood-Mizer is committed to providing you with the latest technology, best quality, and strongest customer service available on the market today. We continually evaluate our customers' needs to ensure we are meeting current wood-processing demands. Your comments and suggestions are welcome.

This documentation includes information on preparing the planer/moulder for operation and operating, servicing and repairing the machine.

GENERAL

Check your planer/moulder as soon as you receive it. Report any transport damage to the transport company immediately.

Lift the planer/moulder using a forklift or pallet jack with lifting capacity of minimum 500kg.

When replacing spare parts, use only original parts and note that any electrical repairs or maintenance must be done by a qualified electrician.

APPLICATIONS

The planer/moulder can be used for planing/moulding and cutting wood, chipboard, board, etc.

Hard materials such as chipboard, teak, MDF, etc. require hard carbide tools.

The planer/moulder is designed for indoor use, with temporary outdoor use during good weather.



IMPORTANT! The machine is intended for moulding/planing wood and wood-based materials only. [See Section 5.2](#) for material specification.

REQUIREMENTS

Planer/moulder can be used in rooms with temperature range from -15°C to +40 C. Ventilation must be mechanical and in accordance with standards.

The planer/moulder must be connected to a dust extractor. Dust extractor must be turned on when the machine is working.

SAFETY DISTANCE



WARNING! Other than the operator, no one should be within 1,5 meters of the planer/moulder's sides or 4 meters from the infeed and outfeed sides during operation. Mark a limit that prevents anyone accidentally wandering into the risk area.

TIPS: An extended outfeed table is practical to use, and prevents anyone coming into the risk area.

1.1 Machine description

The Wood-Mizer planer/moulder is designed for straight and profiled planing of wooden elements used for the production of wooden houses and other construction elements used in building industry and garden programs. All other uses of the planer are forbidden.

The MP220 is a planer/moulder that can work two sides of a workpiece in one action. The planer/moulder is contained in a stable and strong chassis. The planer/moulder table is made of planed cast iron.

The workpiece is fed, lying on the planer table, through the planer by feed rollers as well as an outfeed roller. The rollers are driven by a chain transmission with separate motor. The workpiece is controlled laterally with adjustable fences and pressure rollers.

The work is done using a top cutter and side circular blade. The cutter and circular blade are driven by separate motors, using a belt transmission.

The cutter and feed rollers are covered by a protective cover plate. The cover plate is supplied with a safety switch. A 100 mm (4") dia. hose is connected to circular blade. A 125 mm (5") dia. hose is connected to the cutter.

TABLE SURFACE

Table is made with a highest quality cast. The table surface is specially processed for the highest precision and the best anti-friction qualities.

When the planer/moulder is new, it requires a breaking-in period until the table gets a slightly shinier surface to optimize the anti-friction qualities. During this period it is recommended to use a lubricant or wax on the table.

Using the machine correctly, you will obtain a perfectly smooth surface and a high degree of accuracy.

The planer/moulder should be operated only by an adult who has read and understood the entire operator's manual.

Planer/moulder is built to be durable and easy to operate and maintain.

MACHINE AND SITE PREPARATION

The machine is delivered on pallet. Due to the weight, it has to be transported with auxiliary carrier equipment and in accordance with general safety rules.

Check your planer/moulder as soon as you receive it. Any transport damage must be reported to the transport company immediately.

Most of the planer/moulder is protected against rust, but it will require extra maintenance in the form of lubrication for all the parts not protected against rust. See the Maintenance section.

- Place the planer on a stable and flat base.
- It is recommended to screw the planer/moulder down to the ground, if it does not have to be moved.
- Ensure that there is enough space for the longest boards you want to plane at the in and outfeed sides, and that there is enough space for maintenance and timber stocks.
- Connect the dust hoses and fix using the hose clips on the planer and fan.
- Hang the planer/moulder's electrical cable on the ceiling or protect it in another way. Never step on the cable. The planer/moulder should be connected via an earth-fault protection switch.
- CAUTION! The illumination at the operator's position should be at least 300lx. The light source can not cause stroboscopic effect. Ensure that there is no risk of glare.

SPACE REQUIREMENTS

The planer/moulder needs a space of at least 4 m (13 ft) wide.

The length required depends on the length of the workpieces you want to plane. The minimum length is 9,5 m (31 ft).

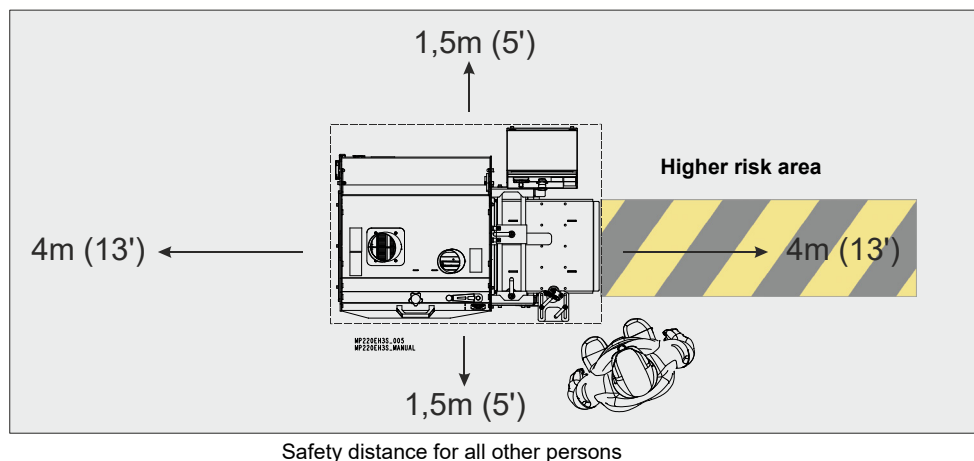

ANCHORING

For the highest safety, the planer/moulder must be anchored to the floor using screws dia. 8-10 mm.

LIST OF THE TOOLS REQUIRED TO WORK WITH THE PLANER/ MOULDER:

- Allen wrench 4mm (supplied)
- Allen wrench 5 mm
- Allen wrench 6 mm
- Flat wrench 10 mm (supplied)

- Wrench 10 mm
- Box wrench 13 mm
- Flat wrench 30 mm (supplied) (for cutter)
- Adjustable wrench 8" or 10" (cutter)
- Slide caliper
- Measuring tape or ruler
- Paraffin oil for grindstone

CHIP EXTRACTOR

MP220 planer/moulder must be connected to chip extractor with a capacity of at least 2 000m³/h. Remember that chip container has to be equipped with an air vent (e.g. a fine net or filter if dust are collected indoors). Poor suction is often due to poor airflow from the chip container. During work in heated rooms, it is necessary to remember that the fan will quickly cool the space if the filtered air will not be supplied back into the building. The fire risk and dust emissions (discharge) must be considered because of chip collection.



WARNING! Because of chip collection there is fire risk and dust emission.

Contact the local authorities for advice in designing a chip collection system to conform with national rules.

It is necessary to set the fan so that will be easy to reach the switch.



IMPORTANT! Remove the chips from the planer/moulder when the work is finished.

CHIP EXTRACTOR TECHNICAL REQUIREMENTS¹

- The chip extractor must be approved according to the CE-standard.
- The airflow "without external connection" must be approx. 2000 m³/hour.
- (The manufacturer's standard indication of airflow.)
- The chip extractor hose diameters for the planer/moulder= 100 mm (4") x 1 and 125 mm (5") x 1.
- Pressure drop in the planer/moulder is 26 mm column of water at 25 m/s.
- Dust extractor airflow should be 2000 m³/h, pressure drop should not exceed 1,5kPa.



IMPORTANT! The dust extractor hoses must be grounded or made with materials not accumulating electrostatic charge.



CAUTION! Always turn on the chip extractor before starting the machine

1. EN 12779:2016-04 standard contains requirements for chip and dust extraction systems equipment with fixed installations.

1.2 Planer/moulder major components

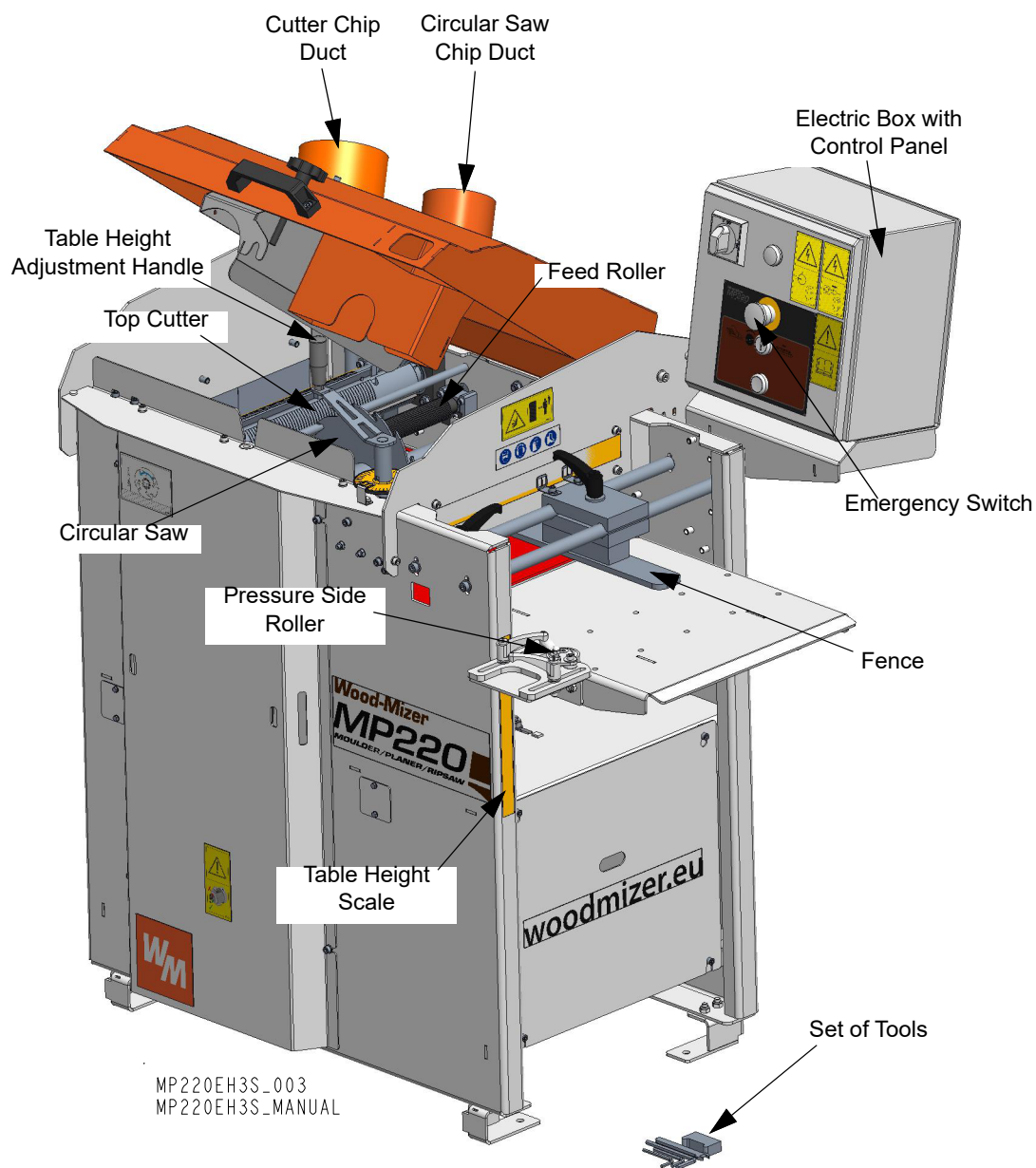



FIG. 1-1 MP220

SECTION 2 SAFETY

2.1 Safety Symbols

The following symbols and signal words call your attention to instructions concerning your personal safety. Be sure to observe and follow these instructions.

 **DANGER!** indicates an imminently hazardous situation which, if not avoided, will result in death or serious injury.

 **WARNING** suggests a potentially hazardous situation which, if not avoided, could result in death or serious injury.

 **CAUTION!** refers to potentially hazardous situations which, if not avoided, may result in minor or moderate injury or damage to equipment.

 **IMPORTANT!** indicates vital information.

 **NOTE:** gives helpful information.

 Warning stripes are placed on areas where a single decal would be insufficient. To avoid serious injury, keep out of the path of any equipment marked with warning stripes.

2.2 Safety Instructions

NOTE: ONLY safety instructions regarding personal injury are listed in this section. Caution statements regarding planer/moulder damage appear where applicable throughout the manual.

- Observe Safety Instructions

 **IMPORTANT!** Read the entire Operator's Manual before operating the planer/moulder. Take notice of all safety warnings throughout this manual and those posted on the equipment. Keep this manual with this equipment at all times, regardless of ownership.

Read all additional manufacturer's manuals and observe any applicable safety instructions including dangers, warnings, and cautions!

IMPORTANT! Only adult persons who have read and understood the entire operator's manual should operate the planer/moulder. The sawmill is not intended for use by or around children. Never operate the planer/moulder under the influence alcohol or any other drugs.

IMPORTANT! The operator of the planer/moulder should get adequate training in the operation and adjustment of the machine.

IMPORTANT! It is always the owner's responsibility to comply with all applicable federal, state and local laws, rules and regulations regarding the ownership and operation of your Wood-Mizer planer/moulder. All Wood-Mizer planer/moulder owners are encouraged to become thoroughly familiar with these applicable laws and comply with them fully while using the planer/moulder.



- Wear Safety Clothing



WARNING! Secure all loose clothing and jewelry before operating this machine. Failure to do so may result in serious injury or death.

WARNING! Wear safety goggles and gloves when operating machinery. Failure to do so may result in serious injury.

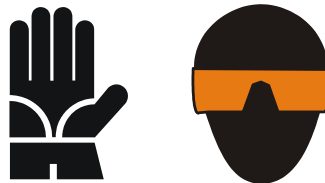

WARNING! Always wear ear, respiration and foot protection when operating planer/moulder.



- Keep the Machine And Area Around Clean



DANGER! Maintain a clean and clear path for all necessary movement around the planer/moulder and lumber stacking areas. Failure to do so will result in serious injury.

- Dispose of Sawing By-Products Properly



IMPORTANT! Always properly dispose of all sawing by-products, including sawdust and other debris.

- Check planer/moulder before operation.



DANGER! Make sure all guards and covers are in place and secured before operating planer/moulder. Check that knobs, screws, nuts, fences, sleeves, planing cutters, planing knives, etc. are properly tightened. Also check that the cutter can rotate freely and that there are no tools in or on the planer/moulder before it is started. Failure to do so may result in serious injury.



WARNING! Always shut off the motor to stop the cutter and saw whenever the planer/moulder is not in use. Failure to do so may result in serious injury.

WARNING! Do not for any reason adjust the motor drive belts with the motor running. Failure to do so will result in serious injury.

- Keep all people away



DANGER! Other than the operator, no one should be within 3 meters of the planer/moulder's sides during operation. Failure to do so will result in serious injury.

- Keep Hands Away

DANGER! Moving parts can cut or crush fingers or hand. Keep hands clear. Make sure all guards and covers are in place and secured before operating the planer/moulder. Failure to do so may result in serious injury.

DANGER! Always be aware of and take proper protective measures against rotating shafts, pulleys, fans, etc. Always stay a safe distance from rotating members and make sure that loose clothing or long hair does not engage rotating members resulting in possible injury.

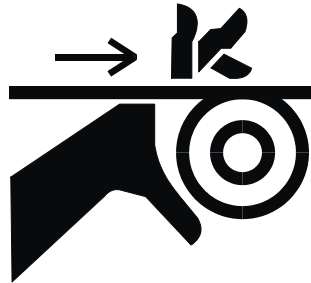

WARNING! Beware of rotating parts. Shut down the sawmill and allow all moving parts to come to a complete stop before removing any guards and covers. Do NOT operate planer/moulder with any guards or covers removed.

DANGER! Before changing the knives and sawing blade or performing any service to planer/moulder, disconnect the power cord from the electric box.

IMPORTANT! Knife and feed assembly covers are equipped with limit switches. After opening the cover, motor will turn off and all moving parts will stop. Limit switches should be always in proper working condition.

Planer/moulder operation



CAUTION! If at any time you need to immediately stop the machine, press the emergency stop button located on the control box.



CAUTION! The workplace always should be good illuminated. The illumination at the operator's position should be at least 300lx. Never use the planer/moulder under the influence of strong medication, alcohol or any other strong drugs.



WARNING! Make sure the knives are properly fastened before starting the motor.



WARNING! Never place tools or hands into the in or outfeed areas when the planer/moulder is running.



IMPORTANT! When starting the machine for the first time, check that cutter rotation direction is as indicated by the arrow located on the side cover. If the rotation direction is incorrect, invert the phases in the phase inverter in the power socket (electric box). Setting the phases in the phase inverter correctly will ensure correct rotation directions of cutter.

 **DANGER!** Always measure the workpiece and set suitable thickness and width before planing. There is a risk of accident if you feed in a workpiece that is not high enough for the feed rollers to get hold of it.

When planing smaller material, it should be stiffened/extended, e.g. with a longer piece of wood.

Never stand in front of the material being fed or received, because it may suddenly kickback uncontrollably towards the operator. This applies to both the in and outfeed sides, although the risk is higher on the infeed side.

 **DANGER!** Planing/moulding/sawing is possible only in direction shown below.

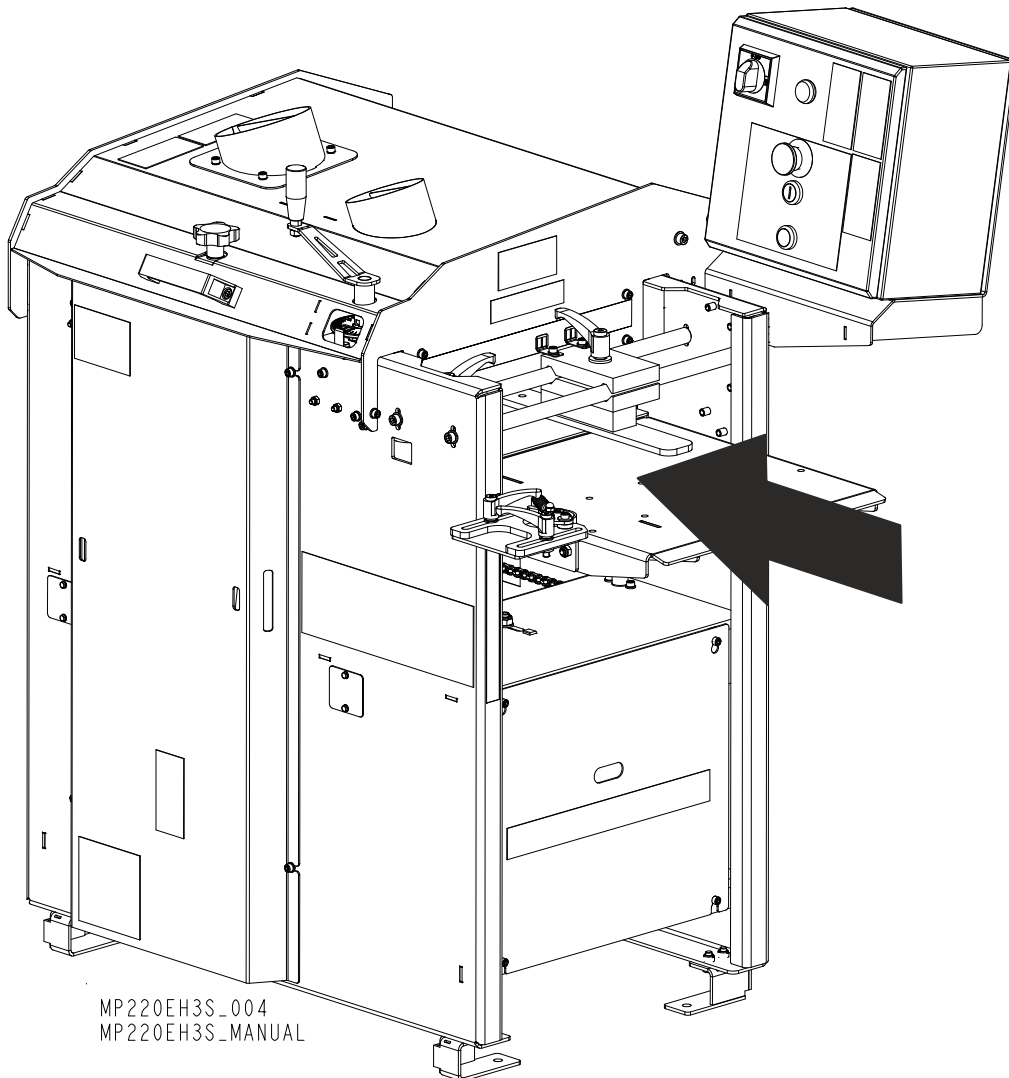

FIG. 2-1

- Use proper maintenance procedures



DANGER! Make sure all electrical installation, service and/or maintenance work is performed by a qualified electrician and is in accordance with applicable electrical codes.

DANGER! Hazardous voltage inside the electric boxes and at the motor can cause shock, burns, or death. Disconnect and lock out power supply before servicing! Keep all electrical component covers closed and securely fastened during mill operation.



WARNING! Consider all electrical circuits energized and dangerous.

WARNING! Never assume or take the word of another person that the power is off; check it out and lock it out.

WARNING! Do not wear rings, watches, or other jewelry while working around an open electrical circuit.



IMPORTANT! Planer/moulder is equipped with emergency switch. It is used to immediately stop the motor in case of emergency. Emergency switch should be always in good condition.

IMPORTANT! Planer/moulder should not be modified by owner. Use only original spare parts.

- Keep safety labels in good condition.



IMPORTANT! Always be sure that all safety decals are clean and readable. Replace all damaged safety decals to prevent personal injury or damage to the equipment. Contact your local distributor or Wood-Mizer Customer Service to order more decals.

IMPORTANT! If replacing a component which has a safety decal affixed to it, make sure the new component also has the safety decal affixed in the same place.

- Fire protection

CAUTION! The work-stand of the planer/moulder should be equipped with a 4 kg or bigger dry powder extinguisher.

Safety Labels Description

See table below for safety labels description.

TABELA 2-0



Label View	Label Number	Description
	096317	CAUTION! Carefully read operator's manual before handling the machine. Observe instructions and safety rules when operating.
	099220	Close guards prior to operating the machine
	099221	CAUTION! Keep safe distance when the machine is operating.

TABELA 2-0

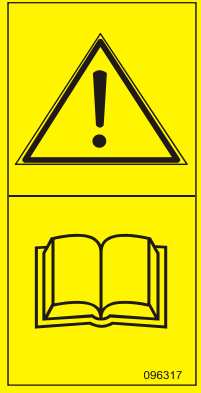

 <p>096316</p>	<p>096316</p>	<p>Electric box opening is possible with the switch in "0" position only.</p>
 <p>096319</p>	<p>096319</p>	<p>Always disconnect the power cord before opening the electric box.</p>
 <p>535252</p>	<p>535252</p>	<p>Start material feed before using variator (before changing feed speed).</p>
 <p>524993</p>	<p>524993</p>	<p>Close guards prior to operating the machine</p>

TABELA 2-0

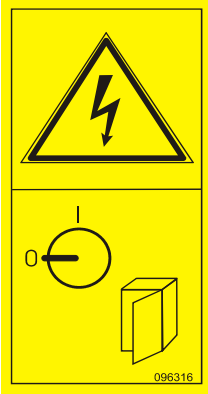
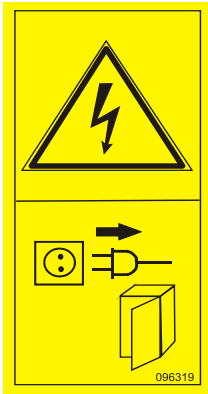
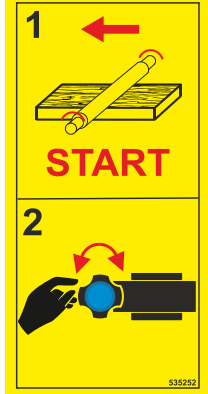

	<p>553360</p>	<p>Check the motor rotation direction</p>
	<p>555611</p>	<p>Cutter rotation direction, maximum planing depth.</p>
	<p>535402</p>	<p>Always wear safety goggles when operating the planer/moulder!</p> <p>Always wear protective ear muffs when operating the planer/moulder!</p> <p>Always wear safety gloves when operating the planer/moulder!</p> <p>Always wear safety boots when operating the planer/moulder!</p>

TABELA 2-0

	<p>089296</p>	<p>Revolutions direction</p>
	<p>087649 502481</p>	<p>Warning stripes</p>
	<p>P85070</p>	<p>CE safety certification</p>
	<p>600701</p>	<p>Proper installation of lockable castors</p>

SECTION 3 SETUP & OPERATION

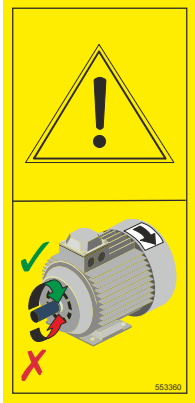
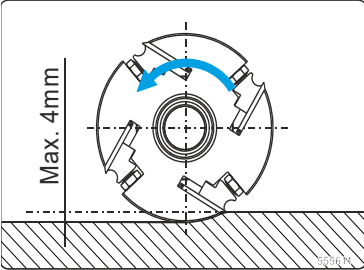
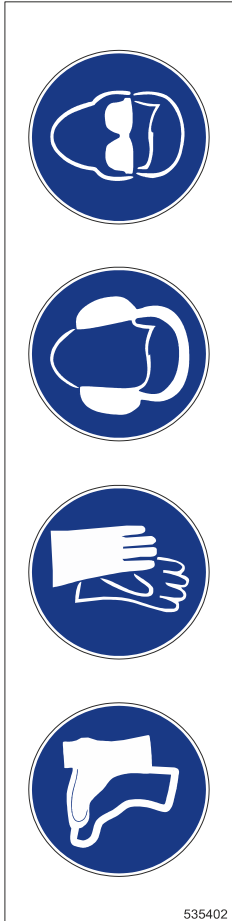
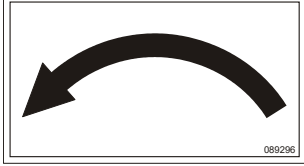
3.1 Planer/moulder setup

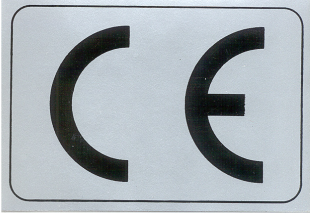
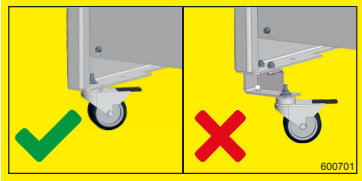

IMPORTANT! Before starting to use the planer/moulder you have to meet the following conditions:

- Set up the planer/moulder on firm, level ground and level the planer/moulder. Secure the planer/moulder to the ground to prevent moving during operation. A cement pad with 8-10 mm diameter anchor bolts is recommended.
- Unscrew the feet. Screw the optional maneuvering wheels to the outer holes in the machine body. The maneuvering wheels must be locked before starting work.
- Indoors the planer/moulder can be operated with the sawdust collection system only.
- The planer/moulder can not be operated when it is raining/snowing and in case of rain or snow the sawmill must be stored under roof or indoors.
- The planer/moulder can be operated in temperature range from -15° C to 40° C only.
- The illumination at the operator's position should be at least 300lx¹.

1. Light source can not cause stroboscopic effect.

3

SETUP & OPERATION

Planer/moulder setup

- The planer/moulder's operator position and E-Stop safety button location are shown below.

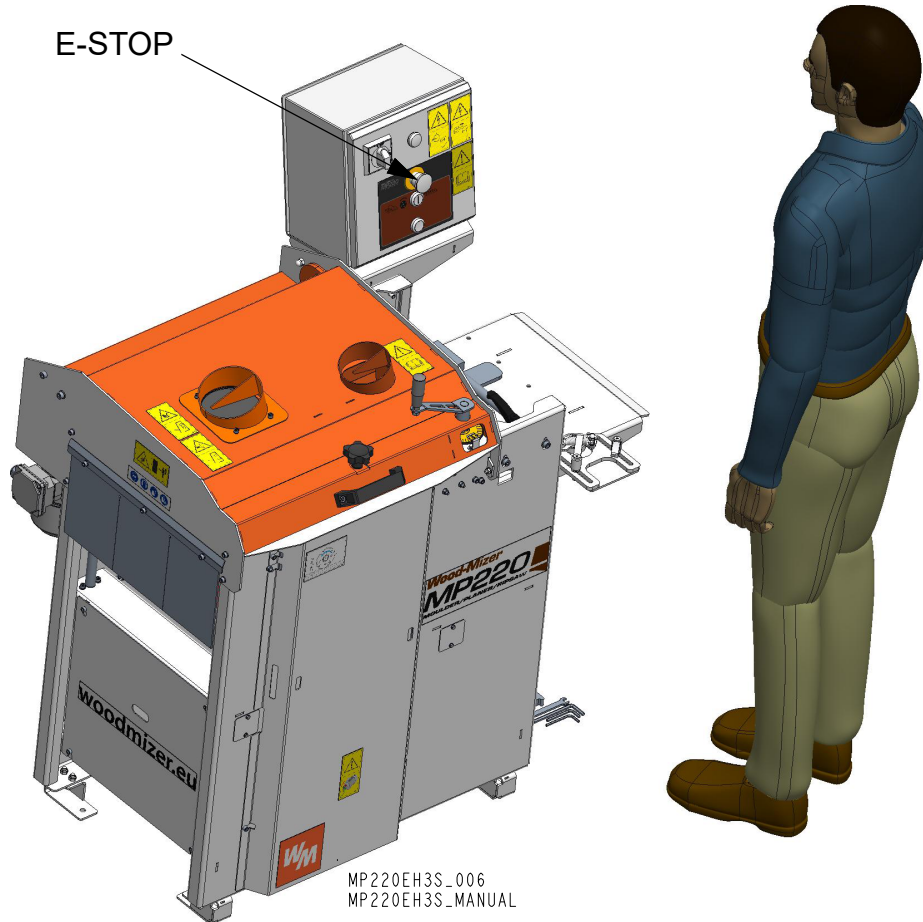

See table 3-1. Have a qualified electrician install the power supply (according to EN 60204 Standard). The power supply must meet the specifications given below.

Power Supply	Fused Disconnect Switch	Suggested Wire Size
3x400 VAC	10 A	1.5 mm ² up to 15 m long
3x230 VAC	16 A	2.5 mm ² up to 15 m long
1x230 VAC	20 A	2.5 mm ² up to 15 m long

TABLE 3-1



IMPORTANT! It is recommended that a 30mA GFI (Ground Fault Interrupter) be used.



IMPORTANT! When starting the machine for the first time, check that main motor rotation direction is as indicated by the arrow located on the motor body (fan guard). If the rotation direction is incorrect invert the phases in the phase inverter in the power socket box). Setting the phases in the phase inverter correctly will ensure correct rotation directions of all sawmill motors.



WARNING! In case of a drive belt break, wait until all rotating parts are completely stop. Failure to do so may result in serious injury or death.



DANGER! Use the inspection window to check cutter rotation direction. To do it, look at the motor fan when planer/moulder is turning on or off. Do not check the cutter rotation direction by touching the cutter with any tool. Failure to do so will result in serious injury of death.

BEFORE STARTING:

- Mount the control box using M6x20 socket head screws (A) and washers (B).

See figure 3-1.

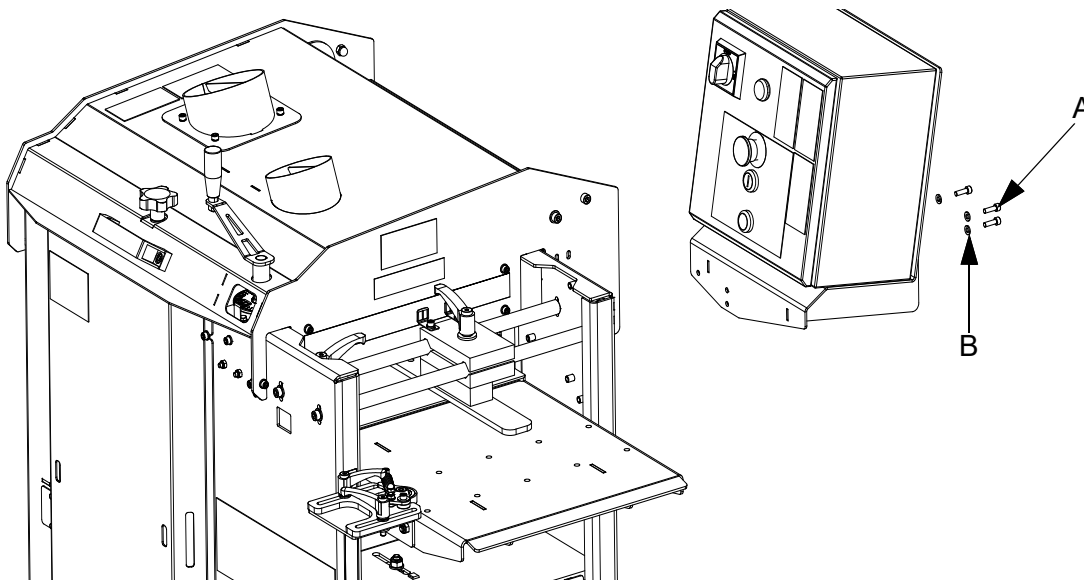

FIG. 3-1

- Check that no tools have been left in the planer.
- Check that the cutters can rotate freely before the safety doors are closed.
- Review the safety instructions!

- Ensure that all cutters can rotate freely.
- Be sure the emergency switch button is released;
- Be sure the upper cover is closed and the limit switch is activated. Be sure all machine's parts are tightened, especially working element covers.
- Be sure that no one than operator is in the high risk area.
- Turn on the chip extractor.



DANGER! Connect the planer/moulder electrical installation. Check the rotational direction. Looking from the transmission, the upper cutter must rotate in the opposite direction to the material feed direction (to the left).

3.2 MP220 planer/moulder operation

3.2.1 Control panel

See figure 3-2. MP220 planer/moulder controls are shown below:

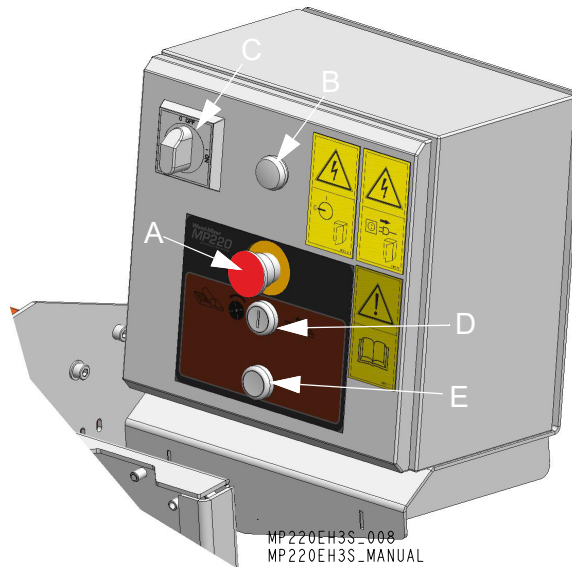

FIG. 3-2

Top red button (A) - the emergency stop switch, which disconnects power to all functions. When the emergency stop switch is pressed, it must be released before restarting the planer/moulder (turn right).

Above the emergency stop switch there is an indicator light (B) which indicates that the power is on. When replacing knives and/or servicing, the power On/Off switch (C) must be in the off position and the power cord must be disconnected. Check if indicator light (B) is off.

The white button (D) starts all motors of the planer. The black button (E) stops the planer's motors.

3.2.2 Top cutter



DANGER! Before you open the safety doors on the planer, ensure that the power is switched off and that the cutters are not rotating.



WARNING! Use protective gloves, particularly when you need to loosen screws that are tightly fastened, or when you are tightening screws (see safety instructions).



WARNING! Beware of the planer knives. It is extremely easy to cut yourself on these, even with the slightest touch.

SETTING THE CUT OF THE TOP CUTTER

The planing thickness is adjusted with the planing table crank (189). The set thickness can be read on the indicator (109) on the machine stand. The indicator must be calibrated. Plane some wood and adjust the top cutter to the correct height. Loosen the cover. The ring above the indicator has a stop screw. Turn the ring so that it shows desired planing height.

The top cutter is fixed to the cover and hung at both ends. Two planing knives are mounted in two cutter sockets in the vertical cutter (planer knife 400 mm HSS). Remaining two planing or moulding knives can be mounted in two other, empty cutter sockets.

DISASSEMBLING, ASSEMBLING AND GRINDING PLANING KNIVES

See figure 3-3.

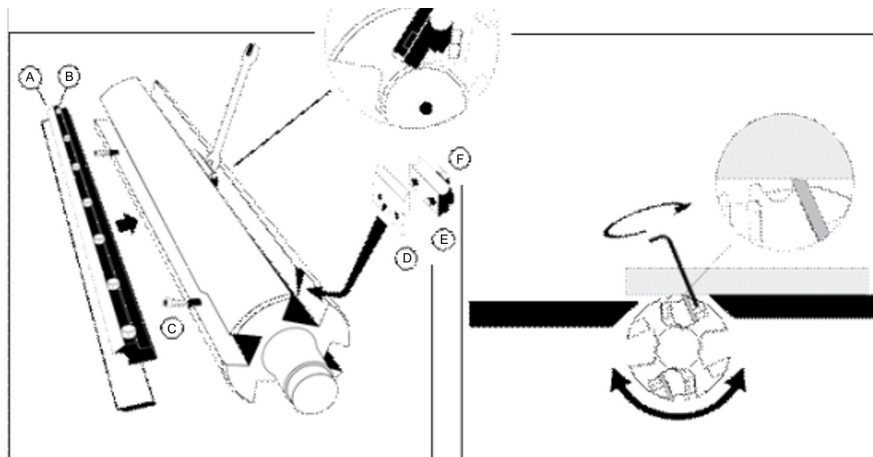

FIG. 3-3

The planing knife is disassembled by loosening the chip breaker's (A) lock screws (B) and then unscrewing the planing knife with adjuster screws (C).

GRINDING THE PLANING KNIVES

Always grind the knives in pairs, so they are the same height, min. 15 mm, otherwise vibrations could occur in the cutter. The grinding angle must be 38 degrees.

ADJUSTING THE PLANING KNIVES

Adjust planing knives (A) so they are on the same level and about 1 mm above the planer table. To adjust knives use the aluminium block (B), delivered together with planer/moulder (it is in the part's bag on the planer table).

See figure 3-4.

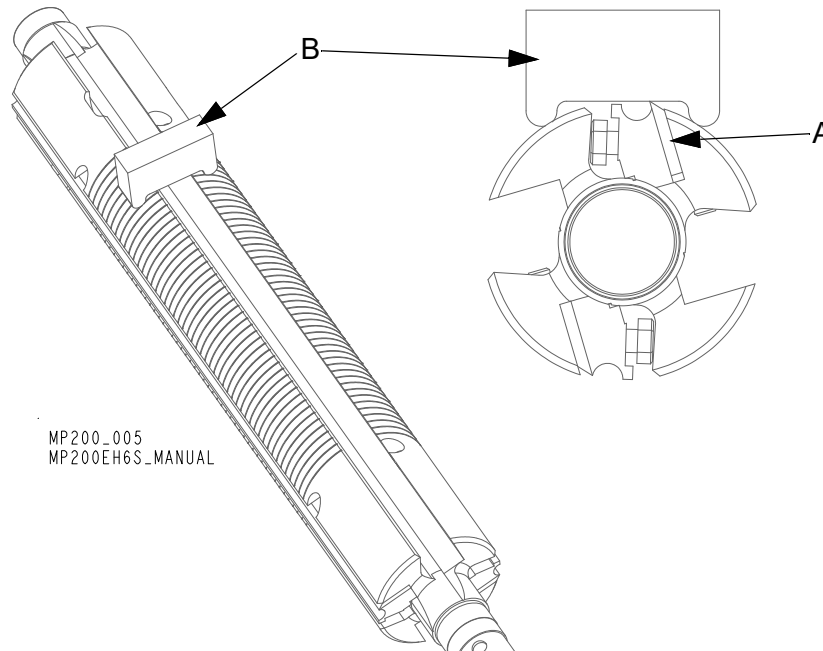

FIG. 3-4

Loosen the chip breaker's lock screws and place the adjustment block above the knife first on the left side of the cutter and next on the right side. Adjust the knife up or down until the knife touches the block. (It can be adjusted also with magnetic adjusting tool. See magnetic adjustment tool manual).

Tighten knife locking bolts counterclockwise. First tighten slightly bolts starting from outside of the cutter, to the middle. Next tighten them.



IMPORTANT! After top cutter bushing cover adjustment or changing planer thickness, scale indicator should be calibrated.

After adjusting or replacing planing knives:

- Check that no tools have been left in the planer.
- Check that all screws have been sufficiently tightened.
- Check that the cutters can rotate freely before the safety cover is closed.
- Review the safety instructions!

3.2.3 Chain transmission with trapezoidal thread adjustment

The chain used to raise and lower the table, must not be slack, but needs to be tensioned enough that teeth mesh correctly.

The chain tension is adjusted with the nut located on the planer/moulder base, under the outfeed table.

Do not adjust the chain tension, when table is raising or lowering. In this case incorrect chain tension can mean that chain has disconnected.

3.2.4 Variable speed motor manual

WARNING! Do not turn feed speed adjustment knob when the feed is off or material is planing/moulding.

ASSEMBLY (IF VARIABLE SPEED MOTOR IS MOUNTED IN PLACE)

Mount feed motor on the last feed roller. Use the lock screw to secure the motor on the roller.

SETTING THE FEED SPEED

To set the feed speed use the knob located on the feed gear. To increase the speed turn the knob right, to decrease - turn left.

MAINTENANCE

Fluid should be visible in the fluid inspection window. Fluid level should be checked when feed gear is not working.

Fluid should be refilled when it is not visible in the inspection window. Use oil for automatic gearboxes or compatible oil according to the table below.

The variator is filled with AGIP BLASIA 32 at the factory and does not normally require an oil change during its life.

The worm gear oil does not normally need changing or topping up during the life of the gear.

See table 3-2. Recommended oil types.

AGIP	BLASIA 32
SHELL	A.T.F DEXRON
ESSO	A.T.F DEXRON
MOBIL	A.T.F 220
CASTROL	DEXTRON II
BP	AUTRAN DX

TABLE 3-2

3.2.5 Circular Saw Replacing

1. Dismount the belt and chain covers. Loosen drive belt tension using the adjustment bolt (A). Remove the belt (B).

See figure 3-5.

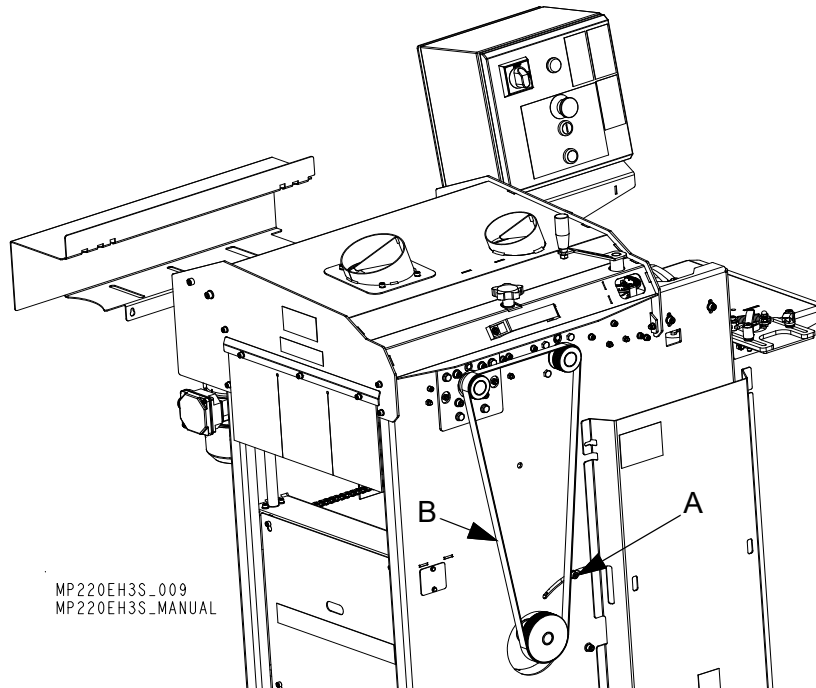

FIG. 3-5

2. Loosen the locking screws (A) on the shaft bearings (two screws on each bearing). Loosen the locking screw on the blade bushing B). Next unscrew the clamping collar (C).

See figure 3-6.

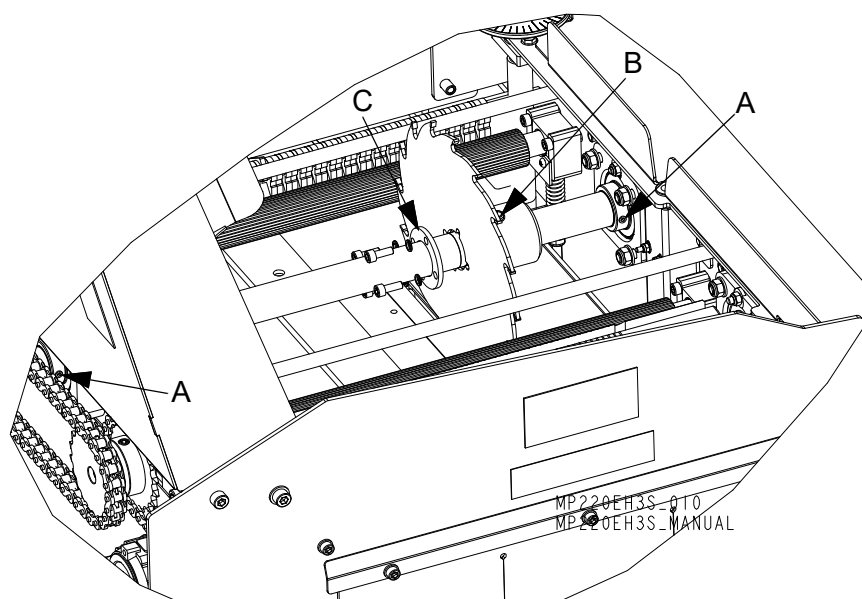

FIG. 3-6

3. Slide the shaft in the direction indicated by the arrow. Remove the clamping collar and replace the circular blade with a new one. Slide the shaft back into its working position. Mount the clamping collar.

See figure 3-7.

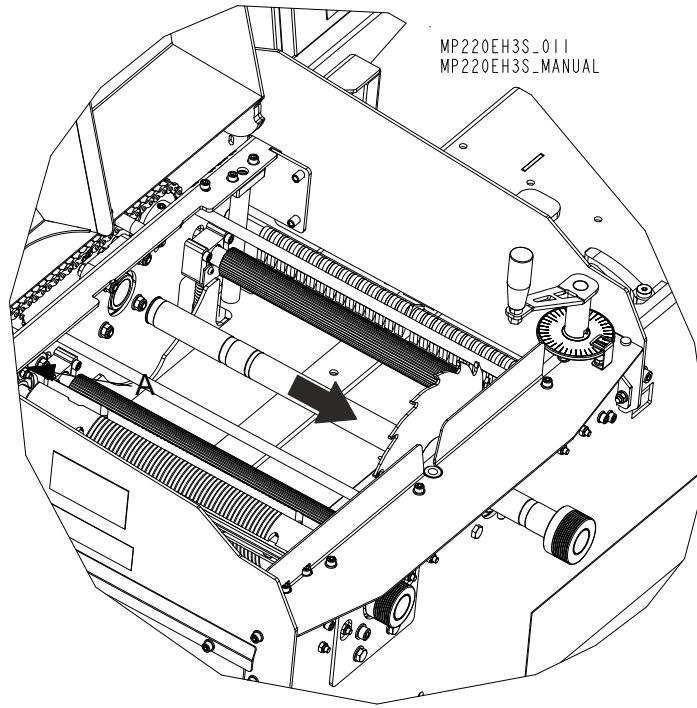
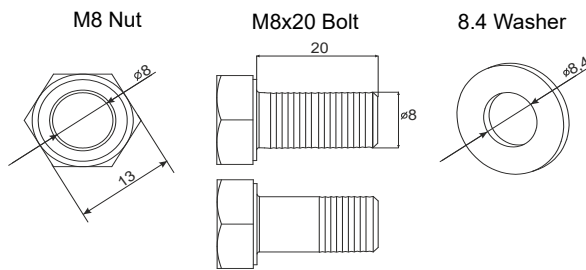

FIG. 3-7

4. Tighten the locking screws on the shaft bearing and on the blade bushing. Mount and tighten the drive belt. Mount the belt and chain cover.

3.2.6 Optional Table Assembling

1. Mount the optional table using the parts and fasteners supplied according to the figure 3-5.



Sample designations of fasteners

See figure 3-8.

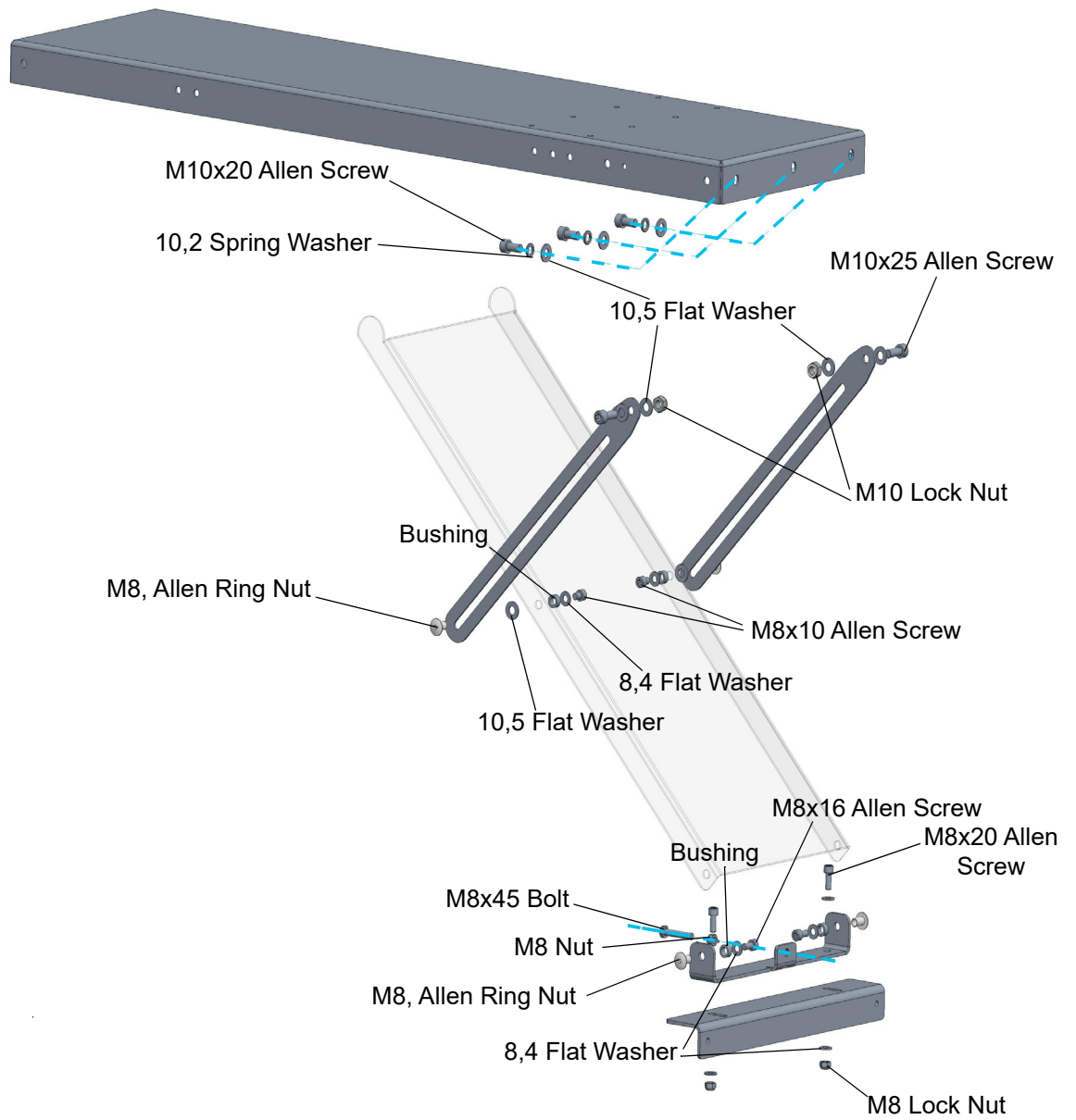

FIG. 3-8

See figure 3-9.

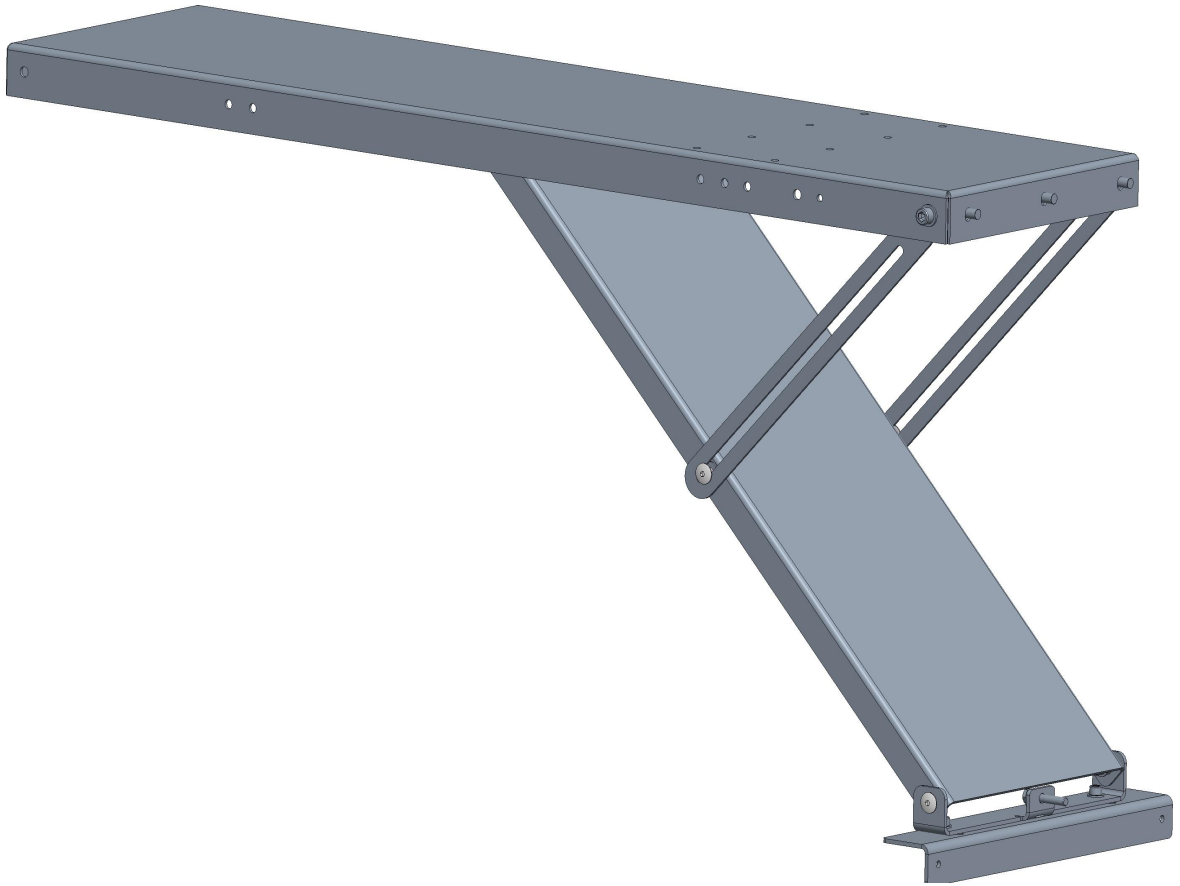

FIG. 3-9

3.2.7 Optional Table installation from the outfeed side.

1. Mount the optional table to the moulder from the outfeed side. Do not tighten the screws. Also table brackets mounting bolts should be loosened.

See figure 3-10.

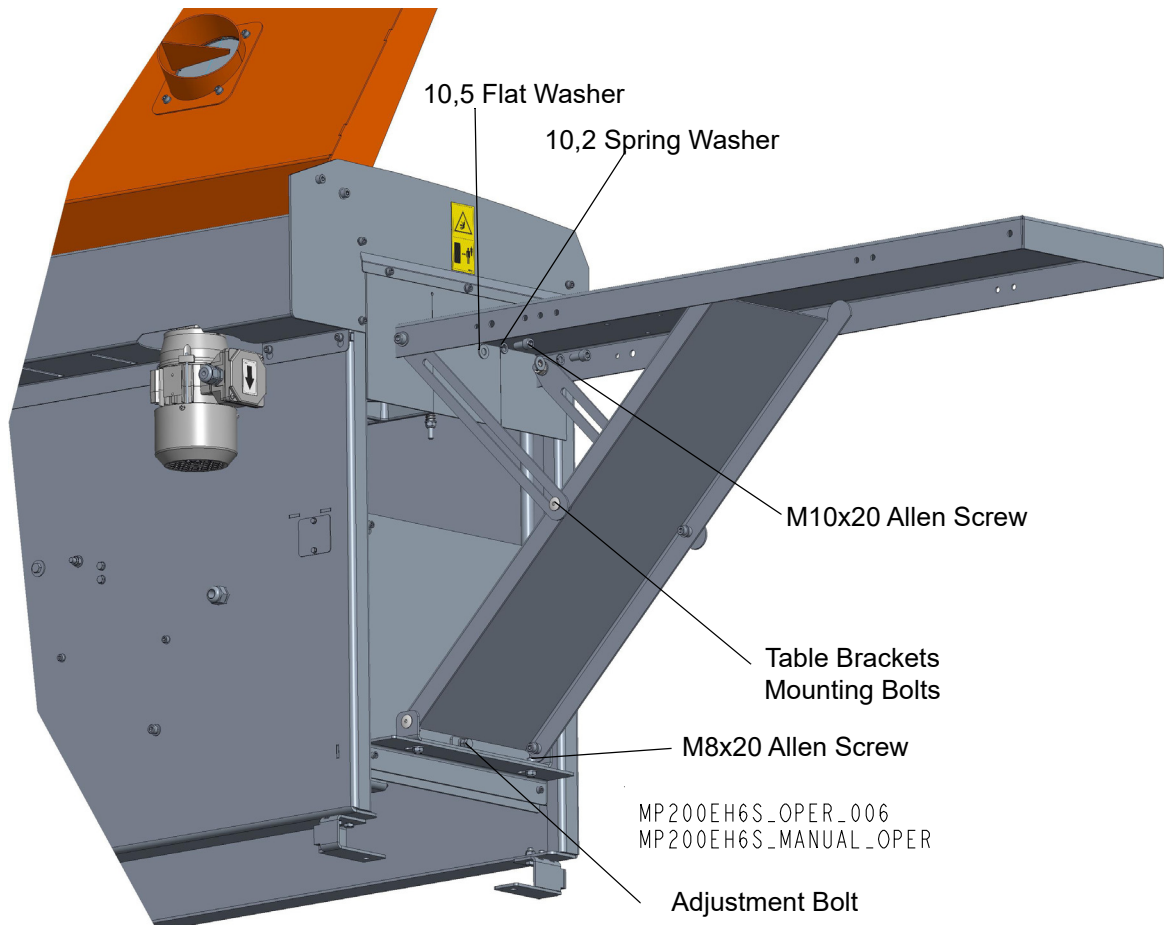

FIG. 3-10

2. Set the optional table at the same level as cast iron table of the moulder, next use the spirit level and adjustment bolt to level the optional table. Tighten the M10x20 and M8x20 allen screws.

3.2.8 Optional Table installation from the infeed side.

1. Dismount the standard infeed table.

See figure 3-11.

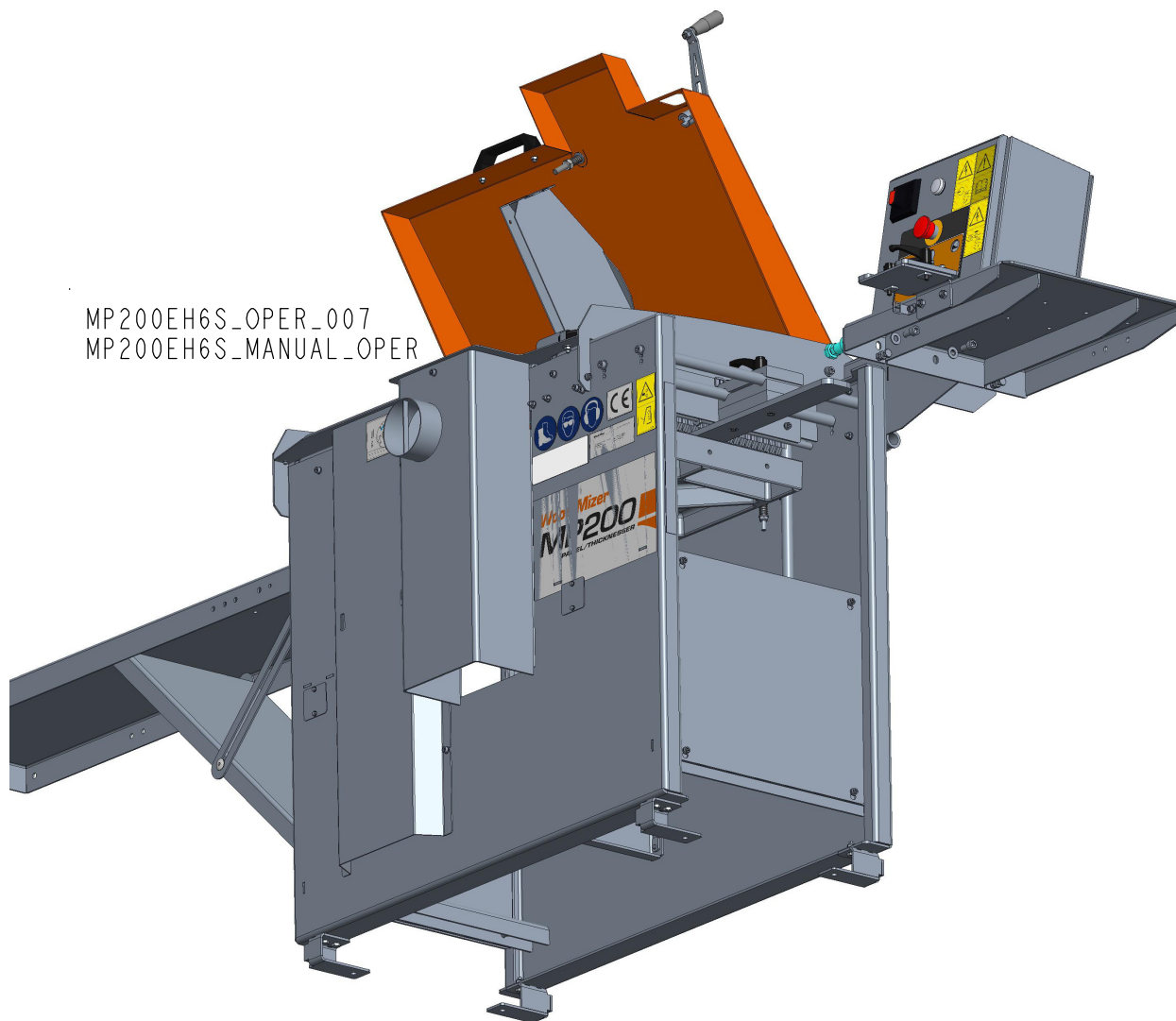

FIG. 3-11

3

Optional Table installation from the infeed side.

2. Mount the optional infeed table. Mount the table bracket to the third hole, as shown on the detail "A". Do not tighten the screws.

See figure 3-12.

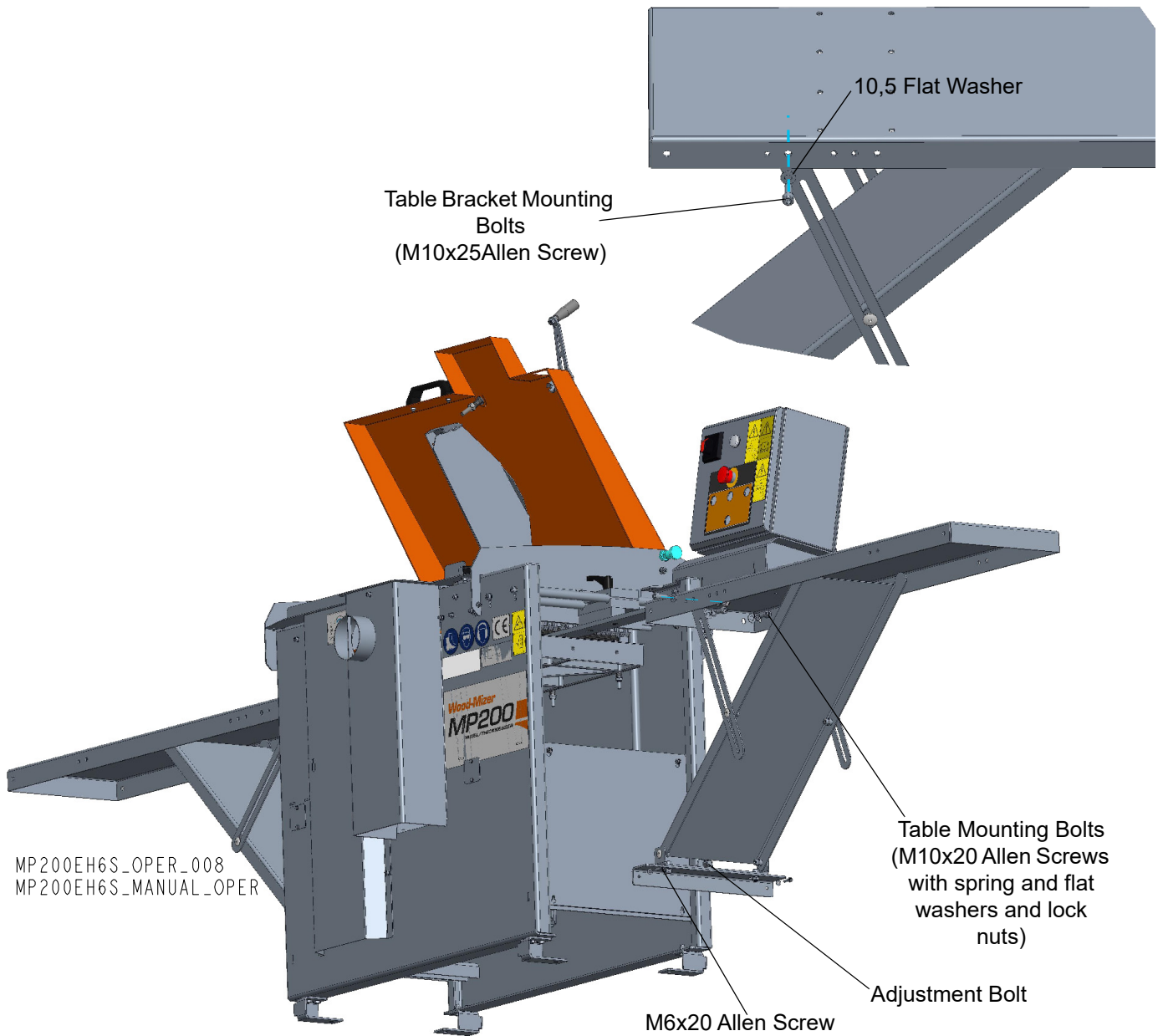



FIG. 3-12

3. Set the optional table at the same level as the cast iron table of the moulder. Next use the spirit level and adjustment bolt to level the optional table. Tighten all screws and bolts.

SECTION 4 MAINTENANCE

This section lists the maintenance procedures that need to be performed.

 **CAUTION!** Always disconnect and lock out power supply before performing any maintenance work, cleaning or servicing the planer/moulder. Failure to do so may result in serious injury.

 **This symbol** identifies the interval (hours of operation duty) at which each maintenance procedure should be performed.

4.1 Wear life

See Table 4-1. Estimated life expectancy of common replacement parts is given in table below. This information is provided so that you may plan ahead in ordering replacement parts. This chart lists estimated life expectancy of common replacement parts if proper maintenance and operation procedures are followed. Due to many variables which exist during machine operation, actual part life may vary significantly.

Part description	Estimated life
Drive belt	1250 hours

TABLE 4-1

4.2 Sawdust Removal

 Remove the excess sawdust and chips from the inside and outside of the planer/moulder using compressed air and brush every eight hours of operation.

4.3 Miscellaneous Maintenance

 1. Oil all chains with Dexron III ATF every fifty hours of operation.

 **CAUTION!** Do not use chain lube. It causes sawdust buildup in chain links.

2. Clean resin from the table and feed rollers. Use solvent if necessary. Lubricate table e.g. with paraffin oil.

 3. Lubricate these parts every 50 hours of operation:

- Feed roller bushing,
- Sprockets

- Table height adjustment chain
- Feed roller drive chain
- Two slide rods and trapezoidal thread
- Cast iron table

 **4.** Every 50 hours check that all screws and bolt connections are tightened. Check that cables and electrical connectors are in good condition.

4.4 Drive Belt Tension Adjustment

4.4.1 Cutter and circular saw drive belt tension adjustment

50

Check top cutter drive belt tension after first 20 hours of operation and every 50 hours of operation thereafter.

1. Remove cover (1) as shown on the figure below.
2. Loosen four mounting bolts (A). Two for each side of the moulder.
3. Tighten the tension bolts (B). The motor will be lifted and the belt will be loosened.
4. Mount the new belt.
5. Loosen the tension bolts to lower the motor and tighten the belt.
6. Check alignment of the motor, cutter and circular blade pulleys. All three pulleys should be in line to avoid premature drive belt wear. Loosen set screw on the shaft to move pulleys. After pulleys alignment, recheck the belt tension.
7. Install cover.

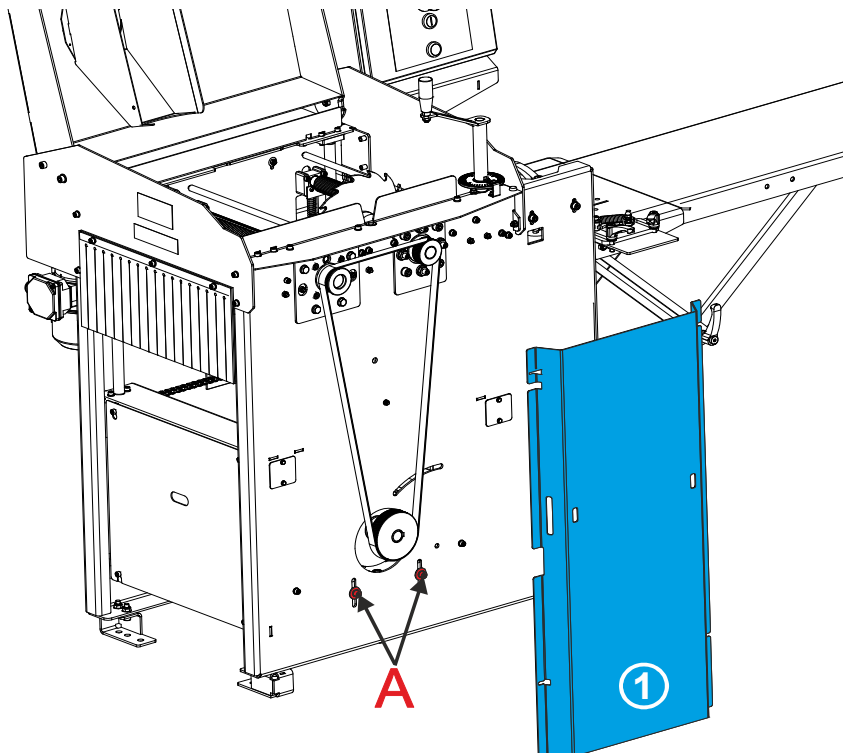

FIG. 4-2

4

MAINTENANCE

Drive Belt Tension Adjustment

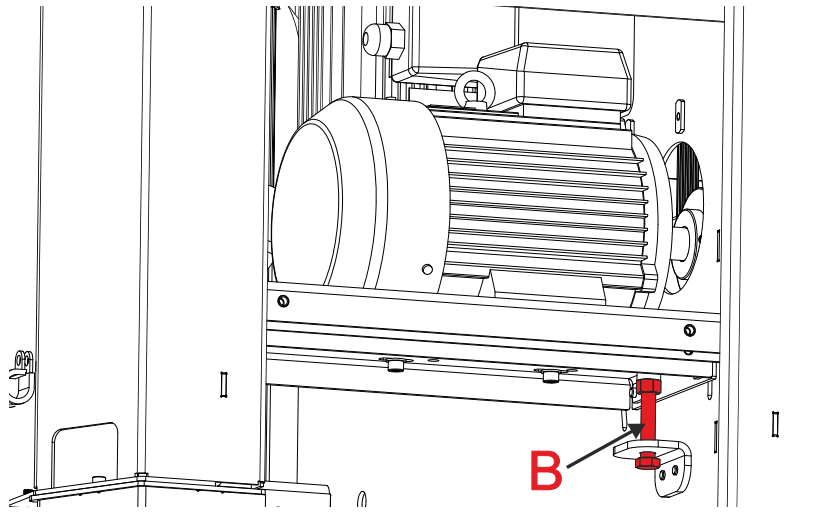

FIG. 4-3

4.4.2 Table chain tension adjustment

Loosen tension roller mounting bolt (A). Use adjustment bolt B to adjust table chain tension.

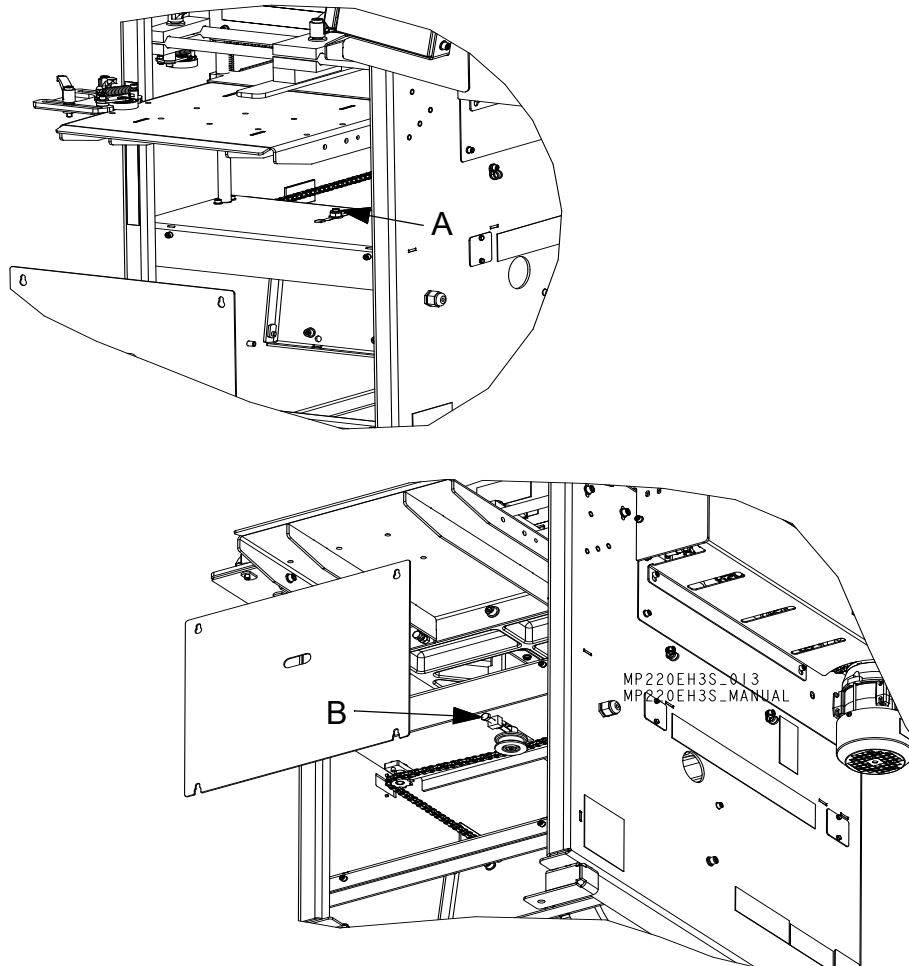

FIG. 4-4

4.4.3 Roller drive chain tension adjustment

1. Unbolt and remove roller drive chain cover (A).
2. Loosen tensioner bolt (B). Move the tensioner up/down to tension the chain properly.

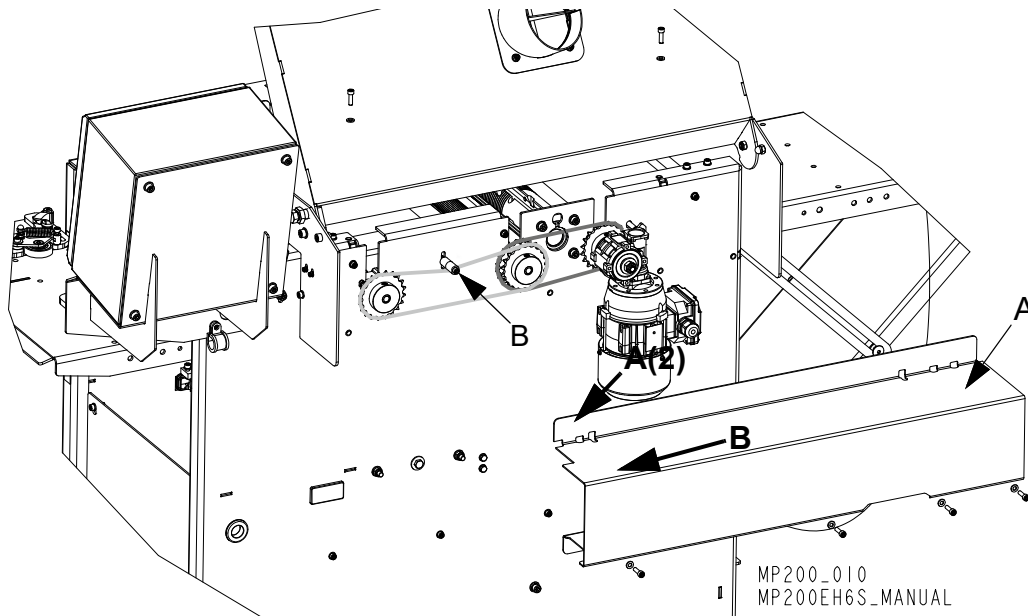

FIG. 4-5

4.5 Long-term storage

If the machine is not used for a long period of time, do as follows:

- Disconnect the power cord.
- Perform all routine actions described above.
- Remove the knives with mounting strips or clamping wedges and store them well lubricated in above zero temperature.
- Loosen the motor belt tension.
- Spray a thin layer of anti-rust coating (such as P.D.R.P) onto the places not protected against rusting.
- Store the machine in a well ventilated room.
- Cover the planer/moulder.

4.6 Replacement of Inserts in Helical Cutterhead



CAUTION! Inserts have sharp edges. Always use protective gear and remain cautious when replacing inserts. Failure to do so may result in serious injury.

Inserts have four cutting edges. If one of the cutting edges becomes dull the insert can be rotated 90 degrees. If the insert is damaged or worn out it should be replaced. Replacement procedure is shown below.

1. Remove the screw (A) with torx screwdriver.
2. Remove or rotate the insert (B).
3. Tighten the screw removed in step one

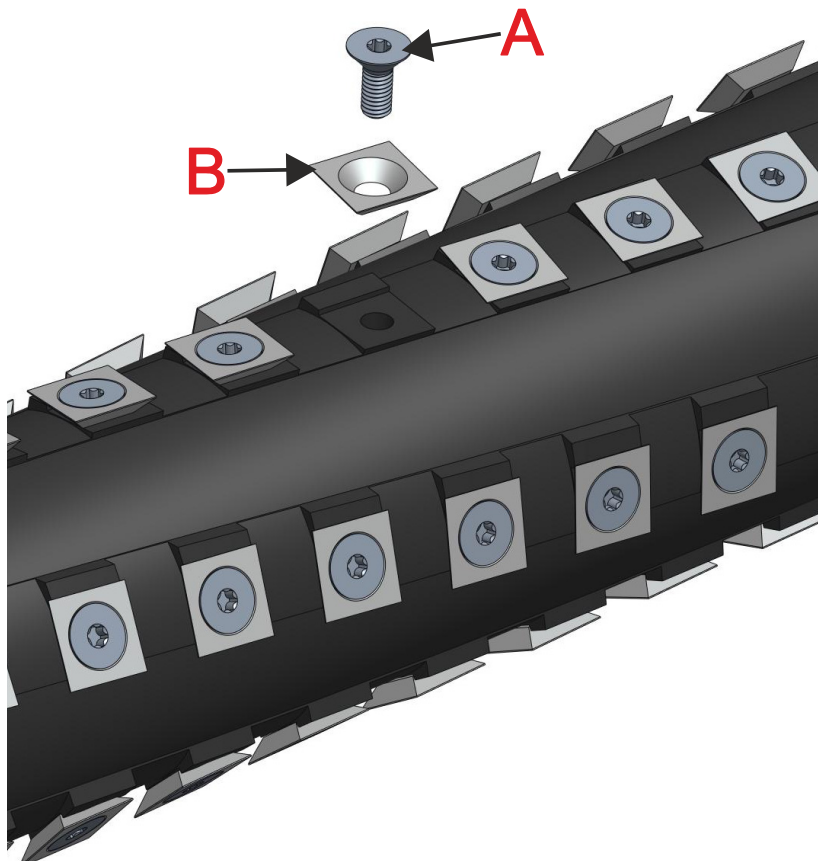

FIG. 4-6

4.7 Safety Devices Inspection

MP220E3S Moulder – Safety Devices Inspection

Safety devices on the machine which must be checked before every shift:

- E-STOP button and its circuit inspection,
- Cutter cover safety switch and its circuit inspection.

1. E-STOP button and its circuit inspection

- Use “I” buttons to start top and side cutter and next feed rollers. The motors should start.
- Press the E-STOP button located on the control box. All motors should be stopped. Pressing any of “I” buttons should not start the motor until the E-STOP button is released.

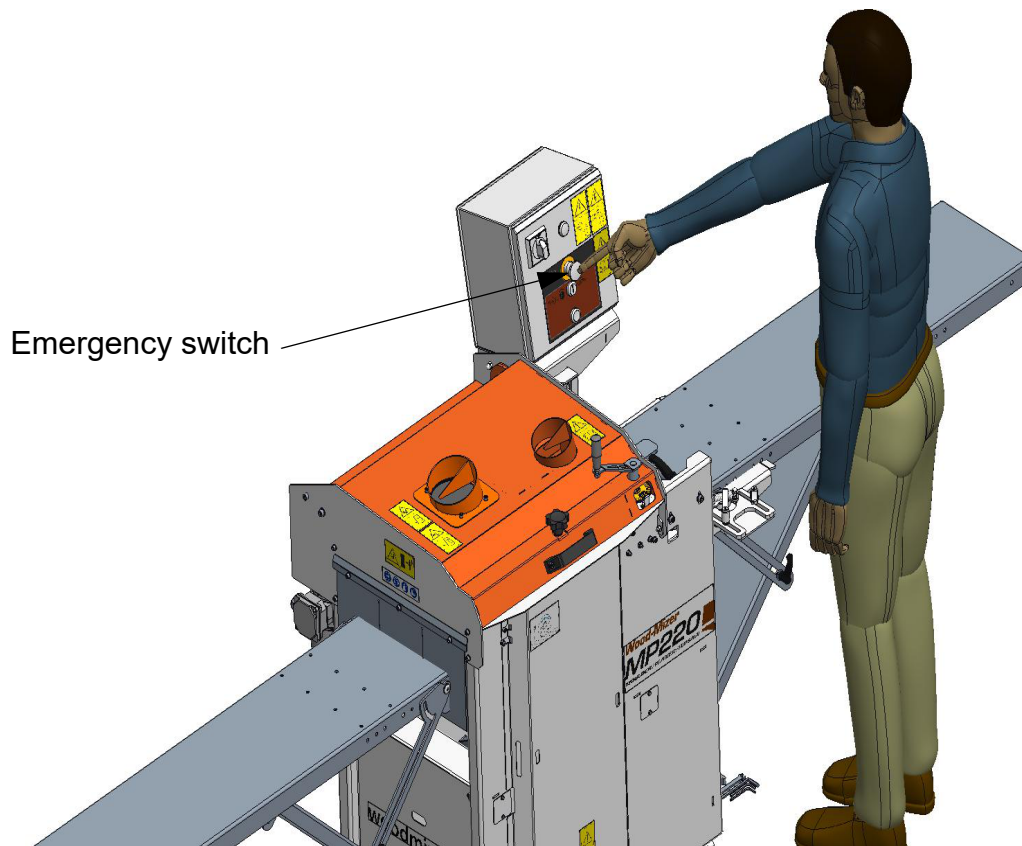

2. Cutter cover safety switch and its circuit inspection



CAUTION! Use extreme caution when opening cutter housing cover if top and side cutters are working (to inspect safety devices).

- Use “I” buttons to start top and side cutter and next feed rollers. The motors should start.
- Be sure the emergency switch button is released;
- Unscrew the cover knob.
- All motors should be stopped.
- Open the cutter housing cover;
- Pressing any of “I” buttons should not start the motors.
- Close the cutter housing cover.
- Screw in the cover knob.
- Motors should remain stopped until they are restarted with the any of “I” buttons.

3. Check the anti-kickback fingers

This machine has the potential for kickbacks. Kickbacks can cause the board to be suddenly and uncontrollably hurled towards the operator. Such action can result in severe injury or death.



DANGER! Be sure the anti-kickback fingers are free from obstruction and are in their downward position. Failure to do so may result in serious injury.



DANGER! Always ensure that there is a sharp point on the anti-kickback fingers before each use of the machine. Do not sharp the anti-kickback fingers! If they are dulled, replace them with new ones.

Check the anti-kickback fingers for wear every 200 hours of operation.

Be sure the anti-kickback fingers are sharp, free from obstruction and are in their downward position.

SECTION 5 PLANER/MOULDER SPECIFICATIONS

5.1 Overall dimensions

See figure 5-1. The overall dimensions of the MP220 Planer/moulder are shown below (all dimensions in millimeters).

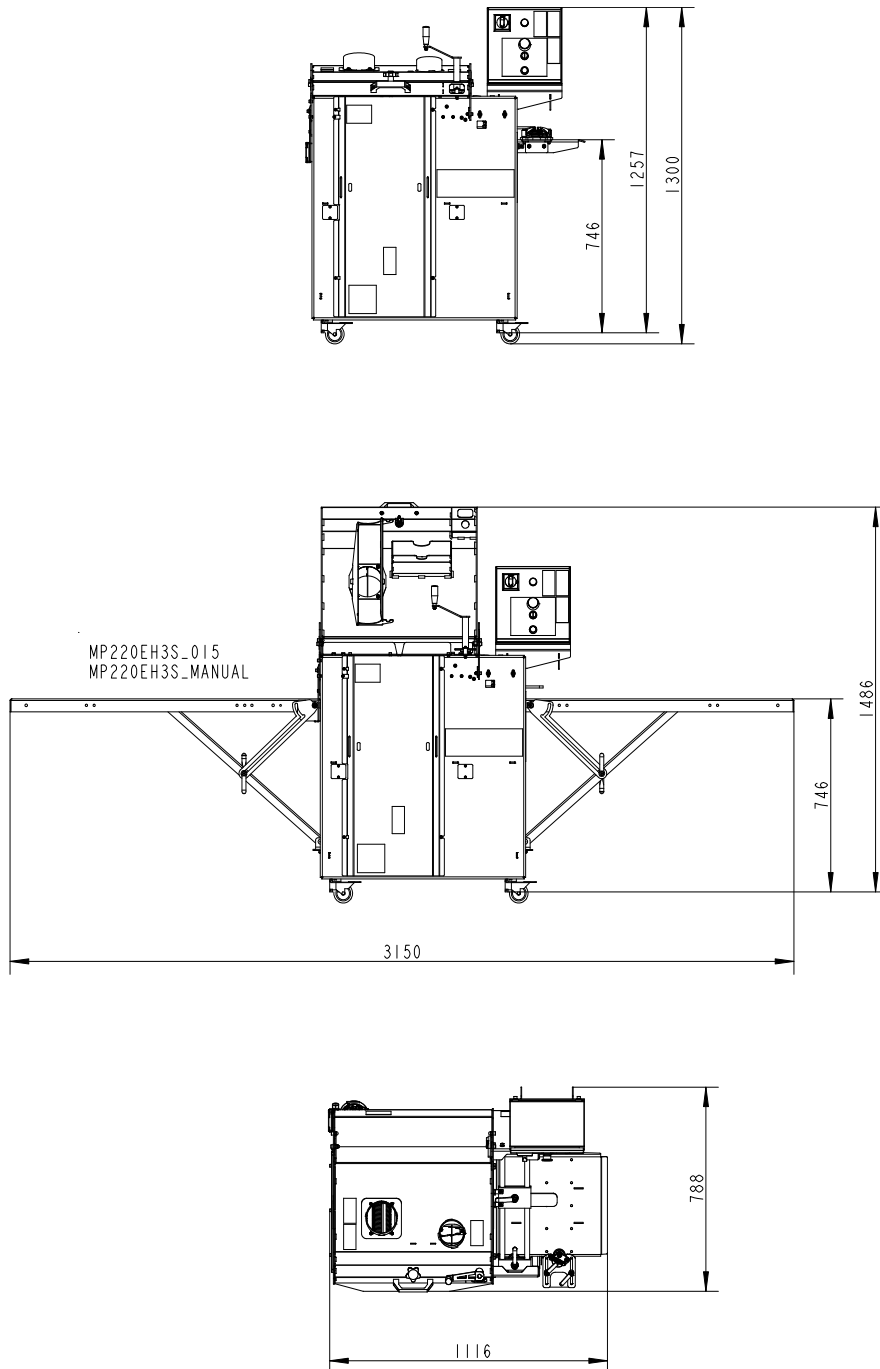

FIG. 5-1 MP220

MP220HTC_014
MP220EH3S_MANUAL

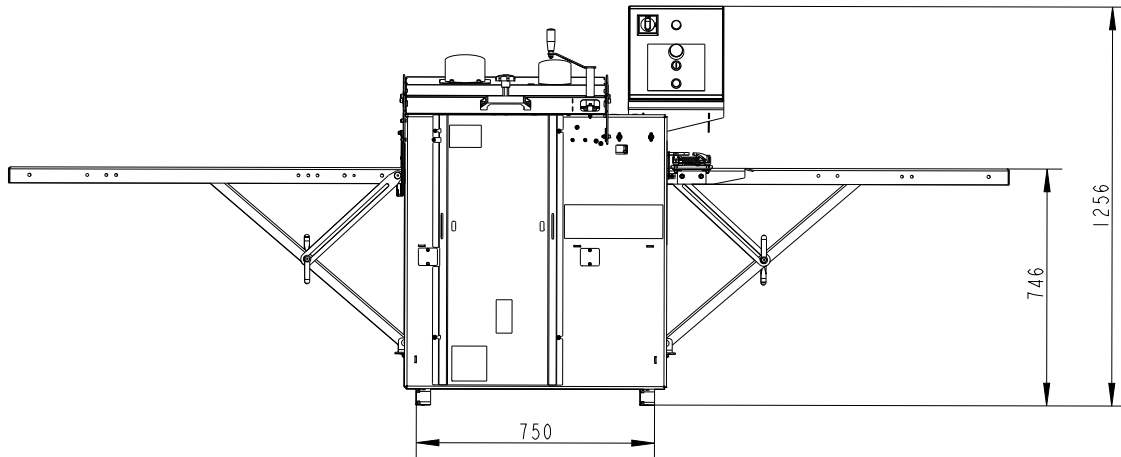

FIG. 5-1 MP220

See table 5-1. The overall dimensions and weight of MP220 are given in the table below.

Planer/moulder type	MP220
Weight with transport box	280 kg
Standard Height	1257mm
Height with Optional Wheels	1300mm
Width	788mm
Standard Length	1116mm
Length with optional table	3150mm

TABLE 5-1

5.2 Specifications of the planer/moulder

See table 5-2. Wood-Mizer planer/moulder nomenclature is given in the table below.

	Volts
MP220EA3S	1 phase 230V CE
MP220EB3S	3 phases 230V CE
MP220EB4S-V	3 phases 230V CE
MP220EH3S	3 phases 400V CE
MP220EH4S-V	3 phases 400V CE
MP220EA3U-V	1 phase 230V ¹
MP220EB4U-V	3 phases 230V ²

TABLE 5-2

¹ American version only

² American version only

See table 5-3. See the table below for specifications of the ECO planer/moulder motors for European markets.

MP220EH3S		
	Top cutter & circular saw motor specifications	Feed motor specifications
Motor Type	Electric Motor	Electric Motor
Rated Voltage	3x400V	3x400V
Rated revolutions	2860 r.p.m.	1400 r.p.m.
Rated power	3kW	0,18 kW
Wood-Mizer Part No.	537386	532802
Wood-Mizer Reducer Part No.	----	533637

TABLE 5-3

MP220EB3S		
	Top cutter motor specifications	Feed motor specifications
Motor Type	Electric Motor	Electric Motor
Rated Voltage	3x230V	3x230V
Rated revolutions	2860 r.p.m.	1400 r.p.m.
Rated power	3kW	0,18 kW
Wood-Mizer Part No.	537386	532802
Wood-Mizer Reducer Part No.	----	533637

TABLE 5-3

MP220EA3S		
	Top cutter motor specifications	Feed motor specifications
Motor Type	Electric Motor	Electric Motor
Rated Voltage	1x230V	1x230V
Rated revolutions	2860 r.p.m.	1580 r.p.m.
Rated power	2.7 kW	0,18 kW
Wood-Mizer Part No.	533651	533656

TABLE 5-3

See table 5-4. Specifications of the PRO planer/moulder motors for European markets are given in the table below.

MP220EH4S-V		
	Top cutter motor specifications	Feed motor specifications
Motor Type	Electric Motor	Electric Motor
Rated Voltage	3x400V	3x400V
Rated revolutions	2860 r.p.m.	2820 r.p.m.
Rated power	4kW	0.37 kW
Wood-Mizer Part No.	537387	533642
Wood-Mizer Reducer Part No.	----	533641
Wood-Mizer CVT Part No.	----	533643

TABLE 5-4

MP220EB4S-V		
	Top cutter motor specifications	Feed motor specifications
Motor Type	Electric Motor	Electric Motor
Rated Voltage	3x230V	3x230V
Rated revolutions	2860 r.p.m.	2820 r.p.m.
Rated power	4kW	0.37 kW
Wood-Mizer Part No.	537387	533642
Wood-Mizer Reducer Part No.	----	533641
Wood-Mizer CVT Part No.	----	533643

TABLE 5-4

See table 5-5. Specifications of the planer/moulder motors for the US market are given in the table below.

MP220EA3U-V		
	Top cutter motor specifications	Feed motor specifications
Motor Type	Electric Motor	Electric Motor
Rated Voltage	1x230V	1x230V
Rated revolutions	2860 r.p.m.	1700 r.p.m.
Rated power	2,7 kW	0,55 kW
Wood-Mizer Part No.	533651-UL	592832
Wood-Mizer Reducer Part No.	----	535749
Wood-Mizer CVT Part No.	----	---

TABLE 5-5

MP220EB4U-V		
	Top cutter motor specifications	Feed motor specifications
Motor Type	Electric Motor	Electric Motor
Rated Voltage	3x230V	3x230V
Rated revolutions	2860 r.p.m.	2780 r.p.m.
Rated power	4 kW	0,37kW
Wood-Mizer Part No.	537387-UL	533642
Wood-Mizer Reducer Part No.		533641
Wood-Mizer CVT Part No.	----	533643

TABLE 5-5

See table 5-6. Feed rate

Planer/moulder type	Feed Rate
MP220EH3S (Constant Feed Speed)	5 m/min
MP200EH4S-V (Adjustable Feed Speed)	2-11 m/min

TABLE 5-6

See table 5-7. The noise level generated by Wood-Mizer planer/moulder is given in the table below^{1 2 3}

Planer/Moulder MP220 Equipped with electric motor	Noise Level
	$L_{WA} \text{ (idling)} = 94,6\text{dB (A)}$ $L_{WA} \text{ (under load)} = 103,5\text{dB (A)}$

TABLE 5-7



IMPORTANT! The total value of hand-arm vibration the operator may be exposed to does not exceed 2.5 m/s^2 . The highest root mean square value of weighted acceleration to which the whole operator's body is subjected does not exceed 0.5 m/s^2 .

See table 5-8. See the table below for planing/moulding material specifications

	MP220
Minimum Cant Height	15 mm
Maximum Cant Height	240 mm
Minimum Cant Width	10mm
Minimum Cant Length	470mm
Maximum Cant Width	400 mm
Maximum Planning Depth	4 mm
Maximum Sawing Depth	80 mm

TABLE 5-8

1. The noise level measurement was taken in accordance with PN-EN ISO 3744:2011 Standard . Value for associated uncertainty $K=2\text{dB}$.
2. The measured values refer to emission levels, not necessarily to noise levels in the workplace. Although there is a relation between emission levels and exposure levels, it is not possible to determine with certainty if preventives are needed or are not needed. Factors that influence the actual level of exposure of the workforce include the characteristics of the work room and the other sources of noise etc. i.e. the number of machines and other adjacent processes. Also, the permissible exposure level value may vary depending on country. This information enables the machine's user to better identify hazards and a risk.
3. The total value of hand-arm vibration the operator may be exposed to does not exceed 2.5 m/s^2 . The highest root mean square value of weighted acceleration to which the whole operator's body is subjected does not exceed 0.5 m/s^2 .

See table 5-9. Other specifications of the planer/moulder are listed below

Cutter Specifications	
Number of knife sockets	4
Top cutter diameter	72 mm
Top cutter width	410 mm
Cutter rotations	5840 r.p.m.
Knives Specifications	
Straight knife height "A"	20 mm
Straight knife thickness "B"	3 mm
Straight knife protrusion "C"	1 mm
Pattern knife protrusion "C"	depends on the knife thickness (see table 5-10)

TABLE 5-9

See figure 5-2.

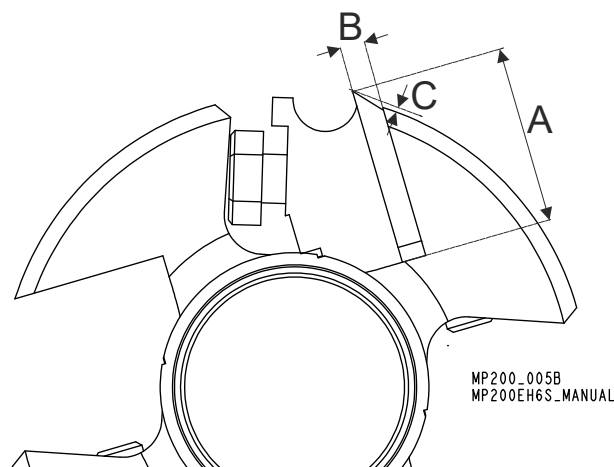

FIG. 5-2

See table 5-10. A relation between the pattern knife protrusion and the thickness is shown below.

Pattern knife thickness	Pattern knife max. protrusion ¹
3 mm	13 mm
4 mm	21 mm
5mm	29 mm

TABLE 5-10

¹ According to EN 847-1:2005 European Standard

EC declaration of conformity according to EC Machinery Directive 2006/42/EC, Annex II, 1.A

Manufacturer:

Wood-Mizer Industries sp. z o.o.
Nagórna 114, 62-600 Koło; Poland
Tel. +48 63 26 26 000

This declaration of conformity is issued under the sole responsibility of the manufacturer.

Following machine in our delivered version complies with the appropriate essential safety and health requirements of the EC Machinery Directive 2006/42/EC based on its design and type, as brought into circulation by us. In case of alteration of the machine, not agreed by us, this declaration is no longer valid.

We, the undersigned herewith declare, that:

Designation of the machine: **Planer/Moulder**
TYPE: **MP220**
Models:
No. of manufacturer:

**Is in conformity with the following
EC directives:**

EC Machinery Directive 2006/42/EC
EC Electromagnetic Compatibility Directive
2014/30/EU

**And is in conformity with the following
Harmonized Standards:**

PN-EN ISO 13849-1:2016-02
PN-EN 60204-1: 2018-12

Responsible for Technical Documentation:

Piotr Adamiec / Engineering Manager
Wood-Mizer Industries Sp. z o.o.
62-600 Koło, Nagórna 114, Poland
Tel. +48 63 26 26 000

Place/Date/Authorized Signature:

Koło, 01.04.2021



Title :

Engineering Manager