



## user manual

Instrukcja obsługi | Руководство пользователя  
Manuel de l'Utilisateur | Betriebsanweisung  
Bruksanvisning | Manual del Usuario  
Betjeningsvejledning | Gebruikershandleiding  
Käyttöohjeet | Manual de utilizare | Bruksanvisning  
Manuale d'uso | Příručka uživatele | Navodila  
za uporabo

Retain for future use  
Zachować do przyszłego użytku  
Сохраните для последующего  
использования  
A conserver pour une utilisation future  
Für zukünftige Benutzung aufbewahren  
Behold for senere bruk  
Säilytä nämä käyttöohjeet tulevaa tarvetta marten  
Opbevar manualen til fremtidig brug  
Bewaren voor gebruik in de toekomst  
Conservare il presente manuale a l'uso futuro  
Păstrați acest manual pentru utilizare viitoare  
Conservar para futuras consultas  
Behall för framtida användning  
Uchovejte pro další použití  
Hranite za prihodnjo uporabo



**Wood-Mizer®**  
**Double Arbor Multirip**  
**Safety, Operation,**  
**Maintenance & Replacement Parts**

---

**MR200**

**rev. A1.00**

---



**Safety is our #1 concern!** Read and understand all safety information and instructions before operating, setting up or maintaining this machine.

*Form #2413*

**Original manual**

# Table of Contents

# Section-Page

<b>SECTION 1</b>	<b>SERVICE</b>	<b>1-1</b>
1.1	Safety & General Information .....	1-1
1.2	If You Need To Order Parts .....	1-1
1.3	Customer and Multi Saw Identification .....	1-1
1.4	If You Need Service .....	1-3
1.5	MR200 Multi Saw Components.....	1-4
<b>SECTION 2</b>	<b>SAFETY INSTRUCTIONS</b>	<b>2-1</b>
2.1	Safety Symbols.....	2-1
2.2	Safety Instructions .....	2-1
<b>SECTION 3</b>	<b>MACHINE OPERATION</b>	<b>3-1</b>
3.1	Intended Use.....	3-3
3.2	Construction .....	3-3
3.3	Operation .....	3-3
3.4	Transport.....	3-4
3.5	Machine Installation .....	3-4
3.6	Multi Saw operation .....	3-7
<b>SECTION 4</b>	<b>MAINTENANCE AND ALIGNMENT</b>	<b>4-1</b>
4.1	Tools:.....	4-1
4.2	Maintenance .....	4-1
4.3	Multi Saw adjustment.....	4-1
4.4	Chipper .....	4-8
4.5	Safety Devices Inspection (Only CE Version).....	4-9
<b>SECTION 5</b>	<b>SPECIFICATIONS</b>	<b>5-1</b>
5.1	MR200 Multi Saw Overall Dimensions .....	5-1
5.2	MR200 Multi Saw Specifications .....	5-1
5.3	Sawdust Extractor Specifications .....	5-3
5.4	Noise Level.....	5-4

## Getting Service

Wood-Mizer is committed to providing you with the latest technology, best quality and strongest customer service available on the market today. We continually evaluate our customers' needs to ensure we're meeting current wood-processing demands. Your comments and suggestions are welcome.

### *General Contact Information*

From Europe call your local distributor or our European Headquarters and Manufacturing Facility in Koło, Nagórna 114 St, Poland at **+48-63-2626000**. From the continental U.S., call our U.S. Headquarter 8180 West 10th St.Indianapolis, IN 46214, toll-free at **1-800-525-8100**. Ask to speak with a Customer Service Representative. Please have your machine identification number and your customer number ready when you call. The Service Representative can help you with questions about the operation and maintenance of your machine. He also can schedule you for a service call.

### **Office Hours:**

<b>Country</b>	<b>Monday - Friday</b>	<b>Saturday</b>	<b>Sunday</b>
Poland	7 a.m.- 3 p.m.	Closed	Closed
US	8 a.m.- 5 p.m.	8 a.m.- 12 p.m	Closed

Please have your vehicle identification number and your customer number ready when you call.

Wood-Mizer will accept these methods of payment:

- Visa, Mastercard, or Discover
- COD
- Prepayment
- Net 15 (with approved credit)



Be aware that shipping and handling charges may apply. Handling charges are based on size and quantity of order.

Technical data are subject to change without prior notice.

Actual product may differ from product images. Some illustrations show machines with optional equipment.

**Branches & Authorized Sales Centers Wood-Mizer Locations (North and South America)**



EUROPE		UNITED STATES
<p> <b>European Headquarters</b>  <b>Wood-Mizer Industries Sp. z o.o.</b>                      Nagórna 114, 62-600 Kolo, Poland                      Tel.: +48-63-26-26-000                      Fax: +48-63-27-22-327  <a href="http://www.woodmizer.eu">www.woodmizer.eu</a></p>		<p> <b>World Headquarters</b>  <b>Wood-Mizer LLC</b>                      8180 West 10th Street                      Indianapolis, Indiana 46214-2400,                      USA                      Tel.: +1-317-271-1542                      Fax: +1-317-273-1011  <a href="http://www.woodmizer.com">www.woodmizer.com</a></p>
<p><b>BELARUS</b>  <b>MOST-GRUPP</b>                      Siemashko 15, k.3                      Minsk 2200116                      Tel.: +375-17-270-90-08                      Fax: +375-17-270-90-08                      GSM: +375-29-649-90-80                      e-mail: <a href="mailto:most-by@mail.ru">most-by@mail.ru</a></p>	<p><b>SWITZERLAND Stefan Wespi</b>                      Maschinen u. Geräte                      Spezialarbeiten GmbH                      Eichstraße 4                      6353 Weggis                      Tel.: +41-413-900-312                      GSM: +41-799-643-594  <a href="mailto:info@woodmizer.ch">info@woodmizer.ch</a>  <a href="http://www.woodmizer.ch">www.woodmizer.ch</a></p>	<p><b>RUSSIA Dariusz Mikołajewski</b>  <b>OOO WOOD-MIZER INDUSTRIES</b>                      141031, Moscow                      Reg., Mytishenski raj., pos. Veshki,                      Zavodskaja str., 3B                      Tel.Fax: +7(495) 788-72-35                      Tel.Fax: +7(495) 641-51-60                      e-mail: <a href="mailto:dariuszm@woodmizer-moscow.ru">dariuszm@woodmizer-moscow.ru</a></p>
<p><b>BULGARIA Kalin Simeonov</b>  <b>Ecotechproduct</b>                      38 Star Lozenski pat str.                      Sofia 1186                      Tel.: +359-2-462-7035                      Tel.: +359-2-963-1656                      Tel./Fax                      : +359-2-979-1710  <b>Kalin Simeonov</b>                      GSM: +3592-963-2559                      e-mail: <a href="mailto:office@ecotechproduct.com">office@ecotechproduct.com</a></p>	<p><b>HUNGARY Wiktor Turoczy</b>  <b>Wood-Mizer Hungary K.F.T.</b>                      Szonyi Ut 67., 2921 Komárom                      Tel./Fax: +36-34-346-255                      e-mail: <a href="mailto:woodmizer@woodmizer.hu">woodmizer@woodmizer.hu</a></p>	<p><b>RUSSIA Far East Wladimir Glazaczew</b>  <b>"WM Service"</b>                      Krasnoretchenskaya Str.111                      680006 Khabarovsk                      Tel./Fax: +7-914-541-1183                      e-mail: <a href="mailto:wms-khv@mail.ru">wms-khv@mail.ru</a></p>

<p><b>CROATIA Krešimir Pregernik</b>  <b>Pregimex d.o.o.</b>  S. Batušićeva 31, 10090 Zagreb  Tel./Fax: +3851-38-94-668  <b>Krešimir Pregernik</b>  GSM: +3851-98-207-106  e-mail: <a href="mailto:Kresimir.Pregernik@gmail.com">Kresimir.Pregernik@gmail.com</a></p>	<p><b>ITALY Pasquale Felice</b>  <b>Wood-Mizer Italia Srl</b>  <b>Cda. Capoiaccio SN</b>  86012 Cercemaggiore  Campobasso  Tel./Fax: +39-0874-798-357  GSM: +39-333-281-03-79  e-mail: <a href="mailto:wmitaliasrl@gmail.com">wmitaliasrl@gmail.com</a></p>	<p><b>SERBIA Dragan Markov</b>  <b>Wood-Mizer Balkan d.o.o.</b>  Svetosavska GA 3/3; P. Fah 25  23 300 Kikinda  Tel./Fax: +381-230-25-754  Tel./Fax: +381-230-23-567  GSM: +381-63-568-658  e-mail: <a href="mailto:office@woodmizer.co.yu">office@woodmizer.co.yu</a></p>
<p><b>CZECH REPUBLIC Miroslav Greill</b>  <b>Wood-Mizer CZ s.r.o.</b>  Za Kasárny 946  339 01 Klatovy  Tel: +420-376-312-220  GMS: +420-608-111-104  <b>Miroslav Greill</b>  GMS: + 420-602-439-799  E-mail: <a href="mailto:woodmizer@woodmizer.cz">woodmizer@woodmizer.cz</a></p>		<p><b>SLOVAKIA Wiktor Turoczy</b>  <b>Wood-Mizer Danubia s.r.o.</b>  Hadovce 5, 94501 Komárno  Tel.: +421-35-77-40-316  Fax: +421-35-7740-326  GSM: +421-905-930-972  e-mail: <a href="mailto:woodmizer@woodmizer.sk">woodmizer@woodmizer.sk</a></p>
<p><b>CZECH REPUBLIC Lubomir Kudlik</b>  <b>Wood-Mizer Moravia</b>  Sovadinova 6  69002 Breclav  Tel./Fax: +420-519-322-443  <b>Lubomir Kudlik</b>  GSM: +420-602-734-792  e-mail: <a href="mailto:info@wood-mizer.net">info@wood-mizer.net</a></p>	<p><b>LATVIA Vilmars Jansons</b>  <b>OBERTS Ltd</b>  Gaujas str. 32/2  LV-2167 Marupe, Rigas Raj.  Tel.: +371-7-810-666  Fax: +371-7-810-655  <b>Vilmars Jansons</b>  GSM: +371-92-06-966  <b>Andris Orols</b>  GSM: +371-28-33-07-90  e-mail: <a href="mailto:andris@oberts.lv">andris@oberts.lv</a></p>	<p><b>TURKEY</b>  <b>Er-Ka Ahsap Profil Kerestecilik San. ve Tic. Ltd. Sti.</b>  Adana Keresteciler Sitesi 191 sk No.41  ADANA  Tel.: +90-322-346-15-86  Fax: +90-322-345-17-07  GSM: +90-533-363-18-44  e-mail: <a href="mailto:info@erkaahsap.com.tr">info@erkaahsap.com.tr</a></p>
<p><b>FINLAND Howard Blackbourn</b>  <b>Oy Falkberg Jordbruk Ab</b>  Falkintie 220  25610 Ylonkyla  Tel.: +358-2732-2253  Fax: +358-2732-2263  <b>Howard Blackbourn</b>  GSM: +358-440-424-339  e-mail: <a href="mailto:falkberg@woodmizer.fi">falkberg@woodmizer.fi</a></p>	<p><b>LITHUANIA Andrius Zuzevicius</b>  <b>UAB Singlis</b>  Savanoriu pr. 187, 2053 Vilnius  Tel.: +370-5-2-32-22-44  Fax: +370-5-2-64-84-15  GSM: +370-620-28-645  e-mail: <a href="mailto:andrius.z@singlis.lt">andrius.z@singlis.lt</a></p> <p><b>Dmitrij Gaiduk</b>  GSM: +370-69-84-51-91  e-mail: <a href="mailto:dmitrijus.g@singlis.lt">dmitrijus.g@singlis.lt</a></p>	<p><b>UKRAINE Ivan Vinnicki</b>  <b>MOST UKRAINA</b>  bul. Myru 3, Bajkivtsi Ternoplskyj r-j  Ternopolska oblast  47711 Ukraine  Tel/Fax: +38 (0352) 52 37 74  GSM: +38 (067) 352 54 34  GSM: +38 (067) 674 50 68  E-mail: <a href="mailto:most-ukraine@ukr.net">most-ukraine@ukr.net</a></p>
<p><b>FRANCE Tizoc Chavez</b>  Wood-Mizer France  556 chemin des Embouffus,  ZAC des Basses Echarrieres  38440 SAINT JEAN DE BOURNAY  Tel: +33-4 74 84 84 44  GSM: +33-607 52 02 82  Mail: <a href="mailto:tchavez@woodmizer.fr">tchavez@woodmizer.fr</a></p>	<p><b>NORWAY Tor Bakken Flaathe</b>  Bakken Flaathe A/S  Lokenvegen 5, 2034 Holter  Tel: + 47-638 74 989  Sales: + 47- 412 80 076  Service: +47- 975 87 588  <a href="mailto:post@woodmizer.no">post@woodmizer.no</a>  <a href="http://www.woodmizer.no">www.woodmizer.no</a></p>	<p><b>UNITED KINGDOM &amp; IRELAND</b>  <b>Wood-Mizer UK</b>  Hopfield Barn  Kenward Road, Yalding  Kent ME18 6JP, UK  Tel.: +44-1622-813-201  Fax: +44-1622-815-534  e-mail: <a href="mailto:info@woodmizer.co.uk">info@woodmizer.co.uk</a></p>
<p><b>SLOVENIA Jan Fale</b>  <b>FAMTEH d.o.o.</b>  Gacnikova pot 2,  2390 Ravne na Koroskem  Tel.: +386-2-62-04-232  Fax: +386-2-62-04-231  <b>Jan Fale</b>  GSM: +386-2-62-04-230  e-mail: <a href="mailto:jan.fale@famteh.si">jan.fale@famteh.si</a></p> <p><b>Matjaz Kolar</b>  Tel.: +386-2-62-04-232  GSM: +386-31-775-999  e-mail: <a href="mailto:matjaz.kolar@famteh.si">matjaz.kolar@famteh.si</a></p>		

<p><b>GERMANY/AUSTRIA Klaus Longmuss</b>  <b>Wood-Mizer GmbH</b>  Dorfstraße 5, 29485 Schletau  Büro  Tel: <a href="tel:+49-5883-988-010">+49-5883 988 010</a>  Werkstatt  Tel: <a href="tel:+49-5883-988-220">+49-5883 988 220</a>  Ersatzteilservice  Tel: <a href="tel:+49-58-83-98-80-250">+49-58 83 - 98 80 250</a>  <b>Scharfservice</b>  Tel: <a href="tel:+49-58-83-98-80-270">+49-58 83 - 98 80 270</a>  E-mail:  <a href="mailto:info@woodmizer.de">info@woodmizer.de</a>  <a href="http://www.woodmizer.de">www.woodmizer.de</a>  <b>Klaus Longmuss</b>  Tel.: <a href="tel:+49-5883-9880-12">+49-5883-9880-12</a>  GSM: <a href="tel:+49-17-298-55-892">+49-17-298-55-892</a>  e-mail: <a href="mailto:KLongmuss@woodmizer.de">KLongmuss@woodmizer.de</a></p>	<p><b>Subagent:</b>  <b>SWEDEN Kjell Larsson</b>  <b>Mekwood AB</b>  Slingan 14, 812 41 Gästrike-Hammarby  Tel.: <a href="tel:+46-290-515-65">+46-290-515-65</a>  <b>Kjell Larsson</b>  GSM: <a href="tel:+46-706-797-965">+46-706-797-965</a>  e-mail: <a href="mailto:kjell.larsson@mekwood.se">kjell.larsson@mekwood.se</a></p>	<p><b>IRELAND</b>  <b>Wood-Mizer Ireland</b>  Stephen Brennan  Cum Lahardane Ballina County Mayo  Tel: <a href="tel:+353-96-51345">+353 96 51345</a>  E-mail: <a href="mailto:brennanmill@ericom.net">brennanmill@ericom.net</a></p>
<p><b>Subagents:</b>  <b>DENMARK Kevin Christiansen</b>  Kevin Christiansen's  savværker PMV  Arnborgvej 40, 7330 Brande- Fasterholt  Mobile: <a href="tel:+45-61468763">+45 61468763</a>  Mobile: <a href="tel:+45-23495828">+45-23495828</a>  <a href="mailto:Info@woodmizer.dk">Info@woodmizer.dk</a>  www.woodmizer.dk</p>	<p><b>ROMANIA Adrian Echert</b>  <b>SC WOOD-MIZER RO SRL</b>  TRANSILVANIEI Nr. 5  Sibiu, Cisnădie 555300  Tel./Fax: : <a href="tel:+40-369-405-433">+40-369-405-433</a>  GSM: <a href="tel:+40-745-707-323">+40-745-707-323</a>  e-mail: <a href="mailto:aechert@woodmizer.ro">aechert@woodmizer.ro</a></p>	<p>Regional Manager - Asia  Robert Moxham  Regional Direction - Asia  Wood-Mizer Asia Manufacturing Co., Ltd.  No.2, Gongyequ 40th Rd. Xitun District,  Taichung City, 40768, Taiwan, R.O.C.  TEL: <a href="tel:+886-4-2359-3022">+886-4-2359 3022</a>  FAX: <a href="tel:+886-4-2359-3205">+886-4-2359 3205</a>  CELL: <a href="tel:+886-9-0568-7708">+886-9-0568 7708</a>  EMAIL: <a href="mailto:RMoxham@woodmizer.com">RMoxham@woodmizer.com</a>  <a href="http://www.woodmizerasia.com">www.woodmizerasia.com</a>  Skype: r.g.moxham</p>
<p><b>NETHERLANDS Gerlo Breukers</b>  Breukers Houtzagerij en Bosbouwmachines  Hazenweg 5, 7481 PC Haaksbergen  Tel: <a href="tel:+31-535741326">+31-535741326</a>  Mobile: <a href="tel:+31-620419412">+31-620419412</a>  <a href="mailto:info@woodmizer.nl">info@woodmizer.nl</a>  <a href="http://www.woodmizer.nl">www.woodmizer.nl</a></p>	<p><b>Subagent:</b>  <b>ROMANIA M. Echert</b>  <b>S.C. Echert Comprod s.r.l</b>  Str. Schitului Nr. 6, Apt.7 etajul-1  725 70 Vatra Dornei, Romania  Tel./Fax: <a href="tel:+40-230-374-235">+40-230-374-235</a>  Tel. : <a href="tel:+40-740-35-35-74">+40-740-35-35-74</a></p>	<p>Regional Manager - Africa  Gavin Prowse  Regional Sales Director - Africa  Wood-Mizer Africa (Pty) Ltd.  Unit 1, Leader Park  20 Chariot Street  Stormill Ext.5  Maraisburg, Johannesburg  South Africa  TEL: <a href="tel:+27-11-473-1313">+27 11 473 1313</a>  FAX: <a href="tel:+27-11-473-2005">+27 11 473 2005</a>  CELL: <a href="tel:+27-71-398-8010">+27 71 398 8010</a>  EMAIL: <a href="mailto:growse@woodmizer.com">growse@woodmizer.com</a>  <a href="http://www.woodmizerafrika.com">www.woodmizerafrika.com</a>  Skype: gavin.prowse</p>

## USA World Headquarters

*Serving North & South America, Oceania, East Asia*

Wood-Mizer LLC  
8180 West 10th Street  
Indianapolis, IN 46214  
Phone: 317.271.1542 or 800.553.0182  
Customer Service: 800.525.8100  
Fax: 317.273.1011  
Email: [infocenter@woodmizer.com](mailto:infocenter@woodmizer.com)

## Brazil Headquarters

*Serving Brazil*

Wood-Mizer do Brasil  
Rua Dom Pedro 1, No: 205 Bairro: Sao Jose  
Ivoti/RS CEP:93.900-000  
Tel: [+55 51 9894-6461](tel:+55-51-9894-6461)/ [+55 21 8030-3338](tel:+55-21-8030-3338)/ [+55 51 3563-4784](tel:+55-51-3563-4784)  
Email: [info@woodmizer.com.br](mailto:info@woodmizer.com.br)

## Canadian Headquarters

*Serving Canada*

Wood-Mizer Canada  
396 County Road 36, Unit B  
Lindsay, ON K9V 4R3  
Phone: 705.878.5255 or 877.357.3373  
Fax: 705.878.5355  
Email: [ContactCanada@woodmizer.com](mailto:ContactCanada@woodmizer.com)

## Europe Headquarters

*Serving Europe, Africa, West Asia*

Wood-Mizer Industries Sp z o.o.  
Nagorna 114  
62-600 Kolo, Poland  
Phone: [+48.63.26.26.000](tel:+48-63-26-26-000)  
Fax: [+48.63.27.22.327](tel:+48-63-27-22-327)

## Branches & Authorized Sales Centers

For a complete list of dealers, visit [www.woodmizer.com](http://www.woodmizer.com)



## SECTION 1 SERVICE

### 1.1 Safety & General Information

Wood-Mizer is committed to providing you with the latest technology, best quality and strongest customer service available on the market today. We continually evaluate our customers' needs to ensure we're meeting current wood-processing demands. Your comments and suggestions are welcome.

The present documentation contains information that should be used when preparing the machine for operation, working with it and when servicing or repairing it, as well.

The MR200 Multi Saw is intended for sawing wood only. See Section Specifications for log size capacities of the machine. The machine must not be used for any other purposes such as cutting ice, metal or any other materials.

Using the machine correctly, you will obtain a high degree of accuracy and efficiency.

The Multi Saw should be operated only by an adult (over 18 year old) who has read and understood the entire operator's manual. The Multi Saw is not intended for use by or around children.

The machine is built to be durable and easy to operate and maintain.

### 1.2 If You Need To Order Parts

From Europe call our European Headquarters and Manufacturing Facility in Kolo, Nagórna Street, Poland at **+48-63-2626000**. Please have the vehicle identification number and your customer number ready when you call. Wood-Mizer will accept these methods of payment:

- Visa, Mastercard, or Discover
- COD
- Prepayment
- Net 15 (with approved credit)

Be aware that shipping and handling charges may apply. Handling charges are based on size and quantity of order. In most cases, items will ship on the day they are ordered. Second Day and Next Day shipping are available at additional cost.

### 1.3 Customer and Multi Saw Identification

Each Wood-Mizer Multi Saw has its own serial number. In addition, when you pick up your multi saw, you will receive a customer number. These two numbers will help expedite our service to you. Please locate them now and write them below so you have quick, easy access to them.

See Figure 1-1 An identification plate is described below.

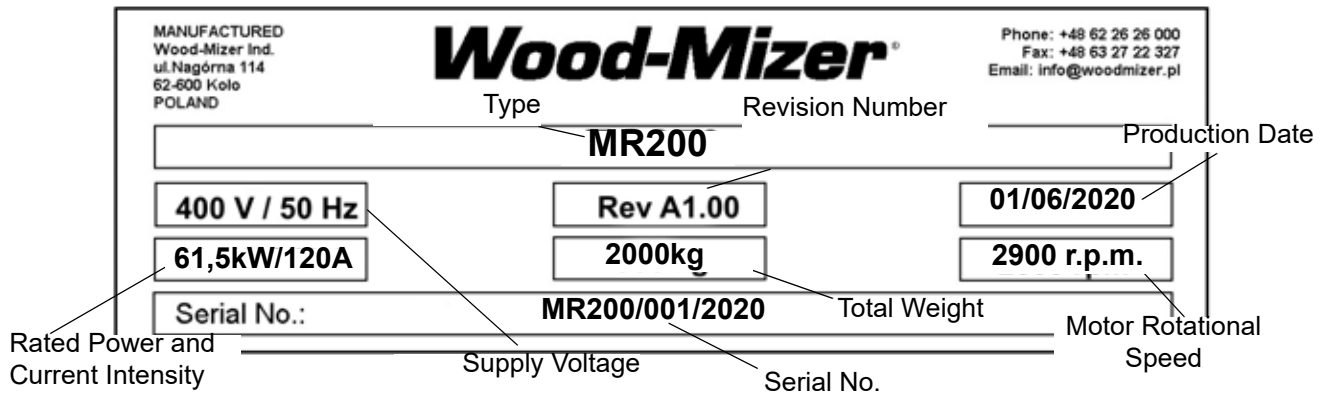

FIG. 1-1

See figure 1-2 See the following figures for the serial number location.

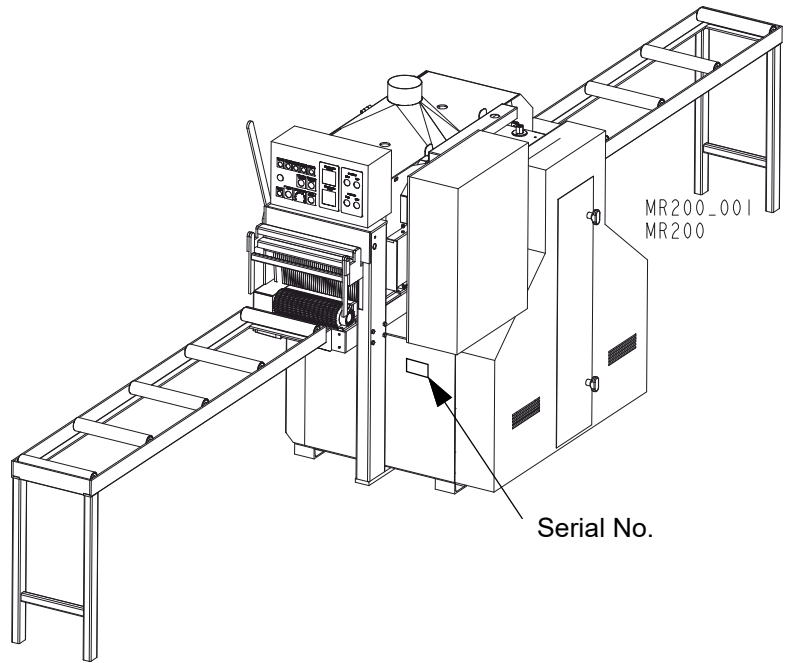

FIG. 1-2

## 1.4 If You Need Service

From Europe call our European Headquarters and Manufacturing Facility in Kolo, Nagórna Street, Poland at **+48-63-2626000**. Ask to speak with a Customer Service Representative. Please have the vehicle identification number and your customer number ready when you call. The Service Representative can help you with questions about the operation and maintenance of your moulder. He also can schedule you for a service call.

### Office Hours:

Country	Monday - Friday	Saturday	Sunday
Poland	8.00 am - 04:30 pm	Closed	Closed

### 1.5 MR200 Multi Saw Components

See figure 1-3 The major components of the MR200 Multi Saw are shown below.

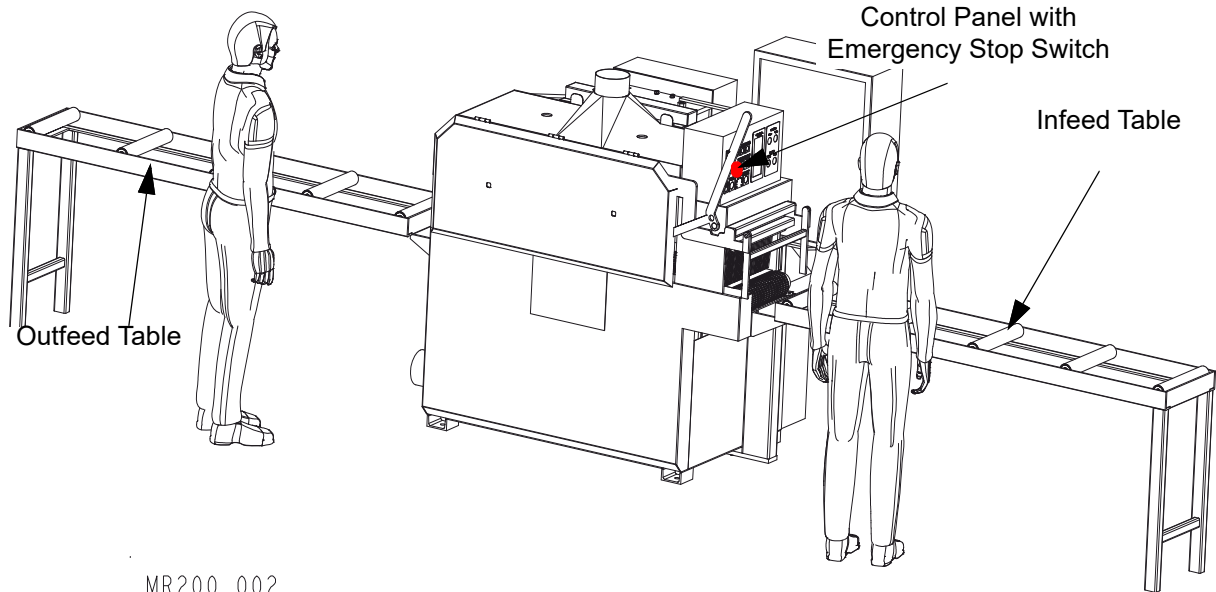

MR200\_002  
MR200

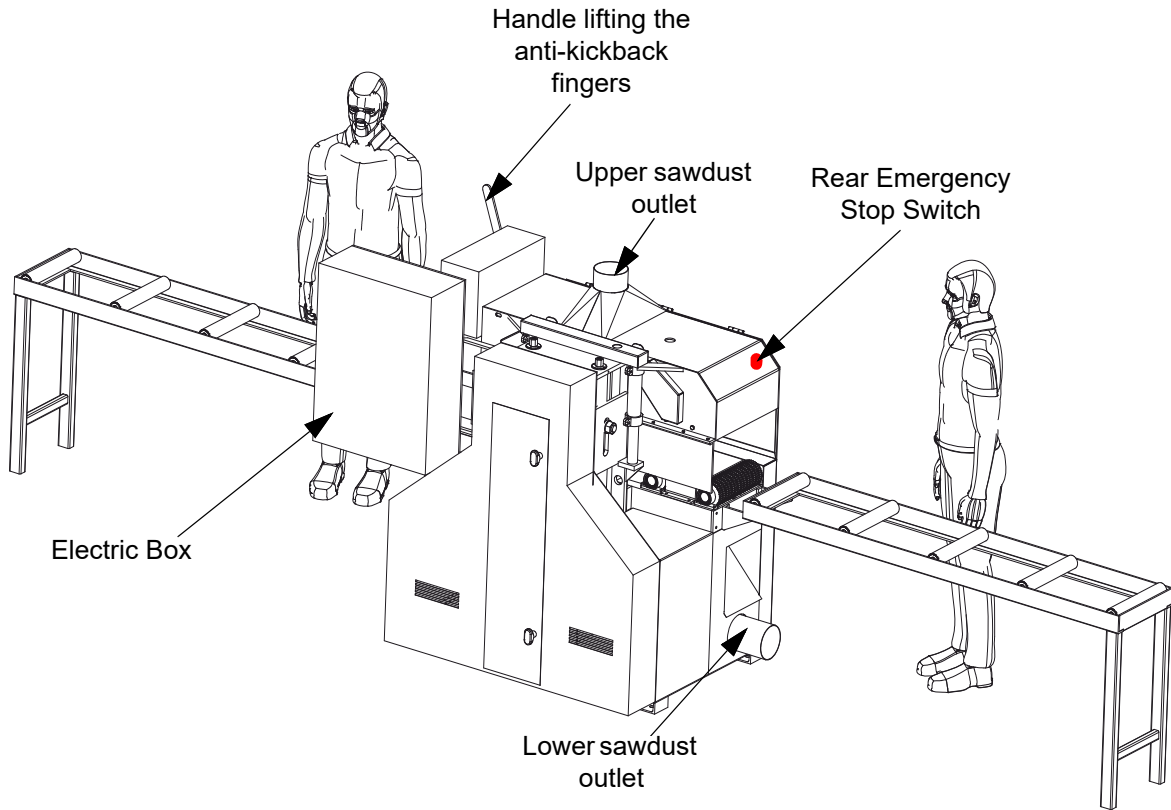

FIG. 1-3 MR200

See figure 1-4 The major components of the MR200 Multi Saw for CE<sup>1</sup> market are shown below .

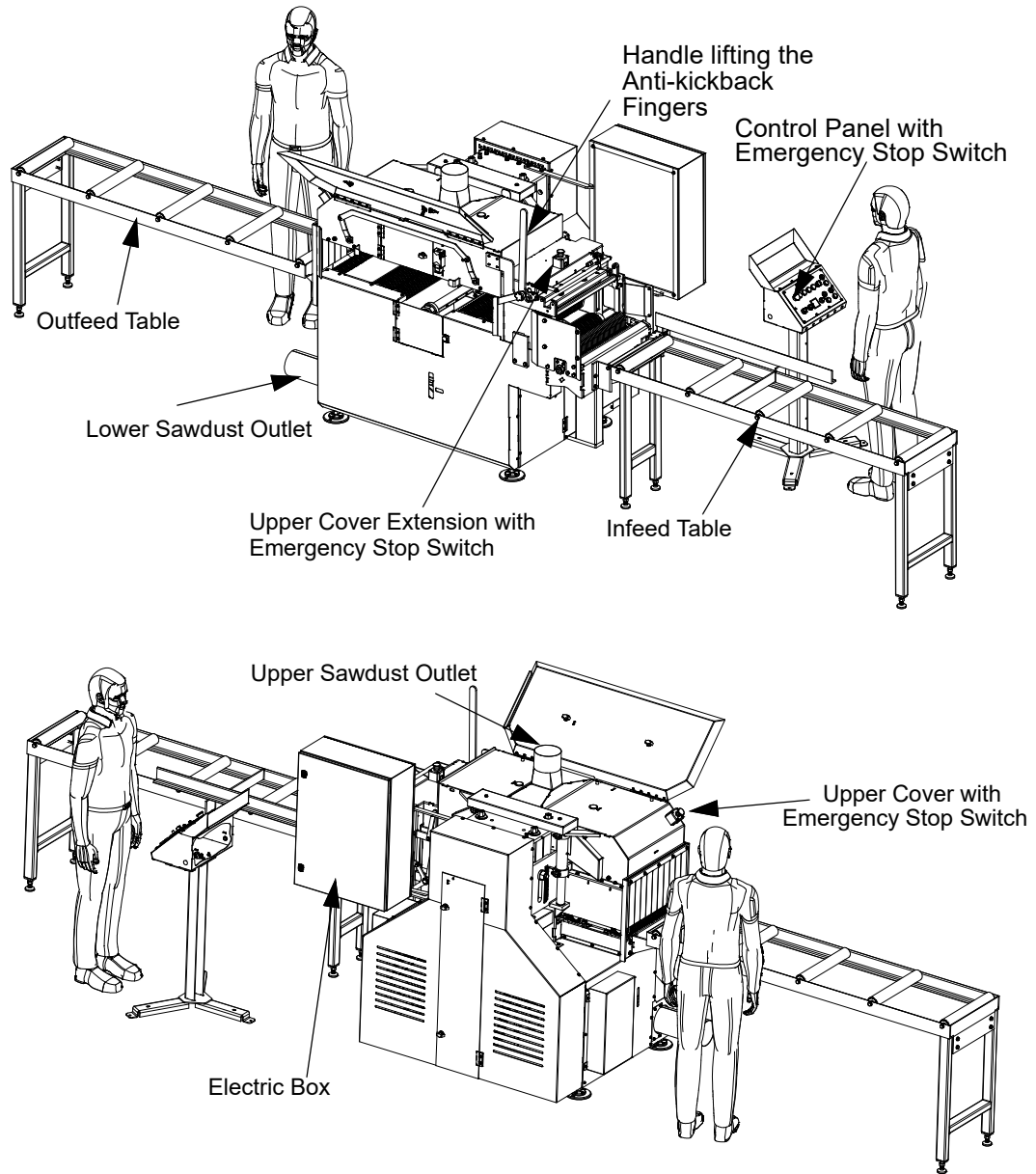



FIG. 1-4 MR200

1 Labeling of products sold in the European Union

## SECTION 2 SAFETY INSTRUCTIONS

### 2.1 Safety Symbols

The following symbols and signal words call your attention to instructions concerning your personal safety. Be sure to observe and follow these instructions.

 The word **DANGER** indicates an imminently hazardous situation which, if not avoided, will result in death or serious injury.

 The word **DANGER** indicates an imminently hazardous situation which, if not avoided, will result in death or serious injury.

 **CAUTION** refers to potentially hazardous situations which, if not avoided, may result in minor or moderate injury to persons or equipment.

 **IMPORTANT!** indicates vital information.

**NOTE:** gives helpful information.

 Warning stripes are placed on areas where a single decal would be insufficient. To avoid serious injury, keep out of the path of any equipment marked with warning stripes.

### 2.2 Safety Instructions

**NOTE:** ONLY safety instructions regarding personal injury are listed in this section. Caution statements regarding only equipment damage appear where applicable throughout the manual.

#### *Observe safety instructions*

 **IMPORTANT!** Read the entire Owner's Manual before operating the Multi Saw. Take notice of all safety warnings throughout this manual and those posted on the machine. Keep this manual with this machine at all times, regardless of ownership.

Also read any additional manufacturer's manuals and observe any applicable safety instructions including dangers, warnings, and cautions.

Only persons who have read and understood the entire operator's manual should operate the Multi Saw. The Multi Saw is not intended for use by or around children.

**IMPORTANT!** It is always owner's responsibility to comply with all applicable federal, state and local laws, rules and regulations regarding the ownership and operation of your Wood-Mizer Multi Saw. All Wood-Mizer owners are encouraged to become thoroughly familiar with these applicable laws and comply with them fully while using the Multi Saw.



### Wear Safety Clothing



**WARNING!** Secure all loose clothing and jewelry before operating the Multi Saw. Failure to do so may result in serious injury or death.

**WARNING!** Always wear safety goggles and gloves when replacing the blade. Changing blades is safest when done by one person! Keep all other persons away from work area when when coiling, carrying or changing a blade. Failure to do so may result in serious injury.

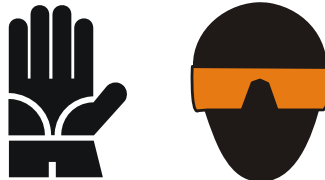

**WARNING!** Always wear protective gloves (compatible with EN 388, Category III) and protective apron (compatible with EN ISO 13688:2013-12, Category I) when operating the machine.

**WARNING!** Always wear eye, ear, respiration, and foot protection when operating or servicing the machine.



**Keep Multi Saw and Area Around Multi Saw Clean**

**DANGER!** Maintain a clean and clear path for all necessary movement around the Multi Saw and lumber stacking areas. Failure to do so may result in serious injury.

**Dispose of sawing by-products properly**

**IMPORTANT!** Always properly dispose of all sawing by-products, including sawdust and other debris.

**CAUTION!** The Multi Saw's work-stand should be equipped with a 4 kg or bigger dry powder extinguisher.

**Check Multi Saw before operation**

**DANGER!** Make sure all guards and covers are in place and secured before operating the Multi Saw. Failure to do so may result in serious injury.



**WARNING!** Always turn off the motor to stop the blade whenever the Multi Saw is not in use. Failure to do so may result in serious injury.

**WARNING!** Do not for any reason adjust the motor/engine drive belts with the machine running. Doing so may result in serious injury.

**WARNING!** Always ensure that there is a sharp point on the anti-kickback fingers before each use of the Multi Saw.

Be sure the anti-kickback fingers are free from obstruction and are in their downward position with the lever released. Failure to do so may result in serious injury.



### Keep Persons Away



**DANGER!** Keep all persons out of the path of moving equipment and boards when operating the Multi Saw. Failure to do so may result in serious injury.

### Keep Hands Away



**DANGER!** Engine components can become very hot during operation. Avoid contact with any part of a hot engine. Contact with hot engine components can cause serious burns. Therefore, never touch or perform service functions on a hot motor. Allow the engine to cool sufficiently before beginning any service function.

**DANGER!** Moving Parts Can Crush and Cut. Keep hands clear. Make sure all guards and covers are in place and secured before operating or towing the Multi Saw. Failure to do so may result in serious injury.

**DANGER!** Always be aware of and take proper protective measures against rotating shafts, pulleys, fans, etc. Always stay a safe distance from rotating members and make sure that loose clothing or long hair does not engage rotating members resulting in possible injury.

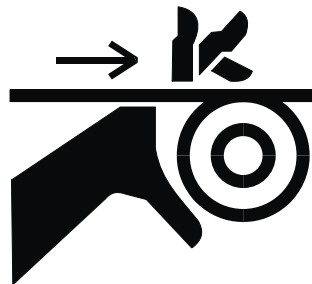

**WARNING!** Always shut off the motor/engine and allow all moving parts to come to a complete stop before removing any guards or covers. Do NOT operate with any guard or cover removed.

**WARNING!** Kickback hazard. Stay clear of area during operation. Follow all anti-kickback service and safety rules. Failure to do so may result in serious injury.



**DANGER!** Before changing the blades or performing any service to the machine, disconnect the power cord from the electric box.

**IMPORTANT!** The guards for the blades and drive are equipped with safety switches. As soon as you open the cover, the motor will get turned off and all moving parts will stop spinning. The safety switches should always be in proper working condition.

**IMPORTANT!** The cutting width setting system is equipped with two safety switches.

### **Use Proper Maintenance Procedures**



**DANGER!** Make sure all electrical installation, service and/or maintenance work is performed by a qualified electrician and is in accordance with applicable electrical codes.

**DANGER!** Hazardous voltage inside the electric disconnect box, starter box, and at the motor can cause shock, burns, or death. Disconnect and lock out power supply before servicing! Keep all electrical component covers closed and securely fastened during Multi Saw operation.



**WARNING!** Consider all electrical circuits energized and dangerous.

**WARNING!** Disconnect and lock out power supply before servicing! Failure to do so may result in serious injury.

**WARNING!** Never assume or take the word of another person that the power is off; check it out and lock it out.

**WARNING!** Do not wear rings, watches, or other jewelry while working around an open electrical circuit.



**IMPORTANT!** The Multi Saw is equipped with two emergency stop buttons: one at the front, and the other at the rear of the machine. They are used to immediately stop the motor and/or the Multi Saw in hazardous situations. The e-stop buttons should always be in proper working condition.



**WARNING!** Visible and/or invisible laser radiation. Avoid eye or skin exposure to direct or scattered radiation.



**WARNING!** No exchange with a different type of laser is permitted, and no additional optical equipment shall be used.



**DANGER!** Operator can not for any reason perform any laser maintenance or repair work. Repair shall only be carried out by the laser manufacturer or authorised persons.

### **Keep Safety Labels In Good Condition**



**IMPORTANT!** Always be sure that all safety warning decals are clean and readable. Replace immediately all damaged safety decals to prevent personal injury or damage to the equipment. Uszkodzoną nalepkę należy jak najszybciej wymienić na nową. Contact Wood-Mizer Customer Service or the Wood-Mizer distributor in your area to order a new decal.

**IMPORTANT!** If replacing a component which has a safety decal affixed to it, make sure the new component also has the safety decal affixed.

### **Introduction**

Only persons who have read and understood the entire operator's manual and were trained in OHS rules should operate the Multi Saw.

The machine may be operated only if electric system, mechanisms and all kinematic drive systems work properly.

It is not allowed to operate the Multi Saw with the guards removed and make any adjustments when the machine drives are engaged.

Use only original spare parts and do not make any modifications to the machine.

Side guards are mounted with screws and protected against accidental opening with interlocked limit switches connected to tachometer. It allows to open the side guards only when spindles are completely stopped.

### **Hazards**

Working on the Multi Saw can create the following hazards:

- Hitting with the material thrown out by circular saws
- Body injury in the consequence of touching rotating saws.
- Sawdust in eyes
- Hearing loss due to noise during machine operation (**sound power level corrected with A characteristic at the workplace is 103.8 + /- 1.0 [dBA]**)
- Electrical shock

### **Protection and Safety Devices**

- *Working area and mechanisms protection guards*

Sawing area and non-working tools area are secured with the steel cover. Blades shaft drive belt transmission, chain transmission and gear transmission are secured with covers. On the infeed side there are four rows of anti-kickback fingers, and there is one row of the upper anti-kickback fingers and flexible cover on the outfeed side,

- *Protective and safety system*

To protect operators against electric shock:

All metal parts are connected to protective conductor.

The machine is equipped with overload protection

Used two Emergency Stop switch to stop quickly the machine.

### **Emergency Stop**

There are three Emergency Stop Buttons: one on the control box (for feeding operator), second one on the outfeed side of the machine upper cover (for operator who remove boards) and the third one on the upper cover extension.

### **Operator's requirements**

- Only operator who get adequate training in safety operation of the machine and signed the training certification can operate the Multi Saw.
- Before operating the machine operators must read section 2 of this manual (machine connection to electrical system) and sections 3 and 4.
- Check if the saws are secured properly.
- Use spacers between saws with diameter recommended by the manufacturer
- Covers must be in good condition.
- Do not remove sawdust and debris manually near moving parts.
- Do not saw wood which may contain any foreign matters.
- Maintain a clean and clear operator's positions and do not let the sawdust buildup around Multi Saw.
- Observe all safety instructions and rules.
- Use ear protection.
- When sawing is finished, use the MAIN SWITCH to switch off the machine and padlock it.

 **DANGER!** The machine should be operated by two persons. Both of them should be on the left side of the machine (from infeed side). It is not allowed to stay along the cutting line when the machine is working.

See Figure 2-1 Operator's work-place and Emergency Stop buttons location.

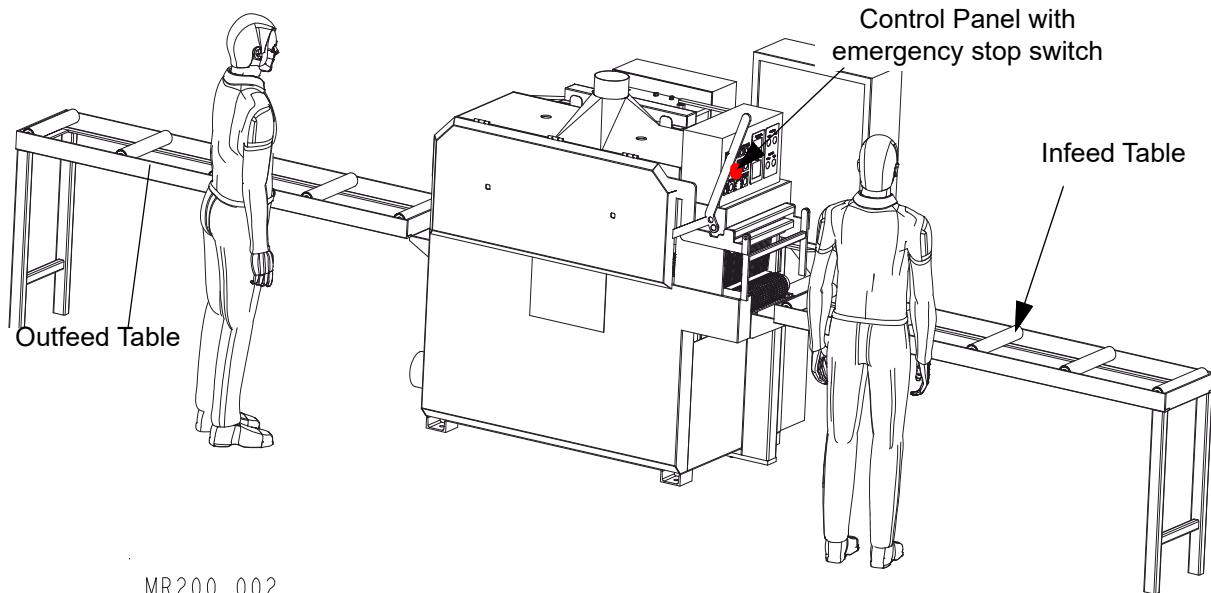

MR200\_002  
MR200

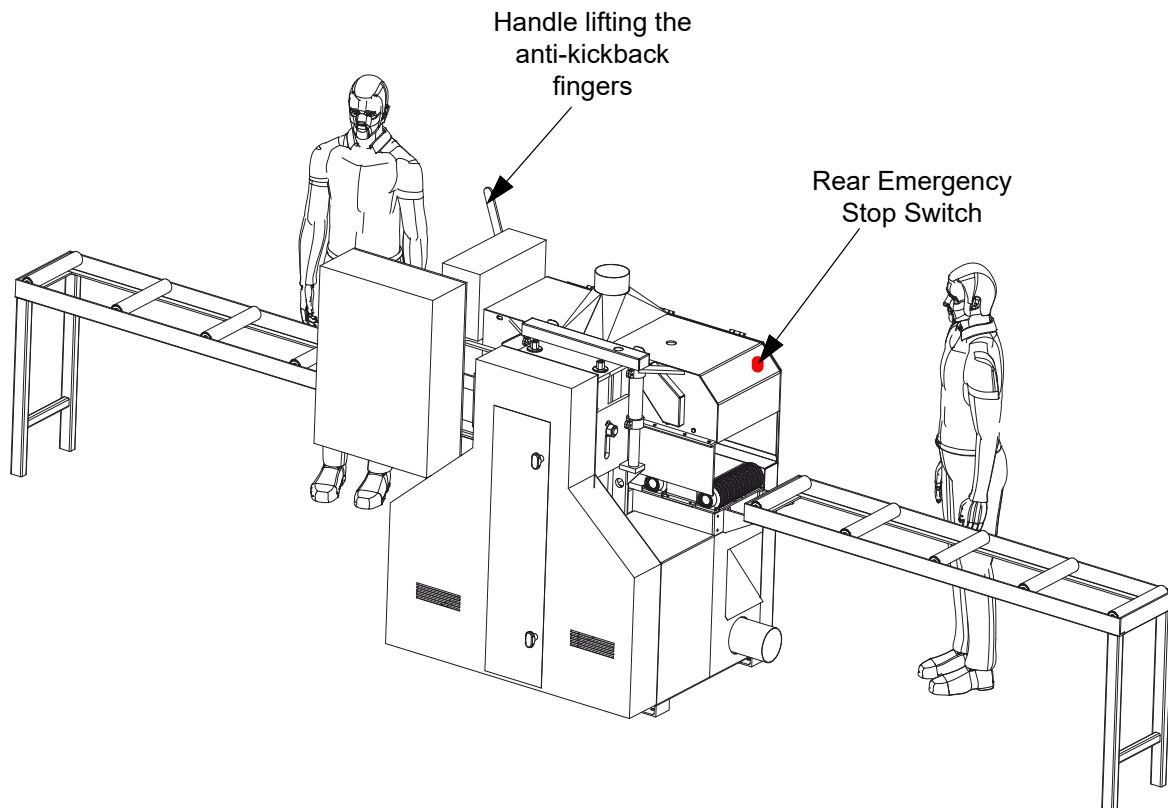

FIG. 2-1 MR200

# 2

## Safety Instructions

### Operator's requirements

See Figure 2-2. Operator's work-place and Emergency Stop buttons location for machine intended for CE market..

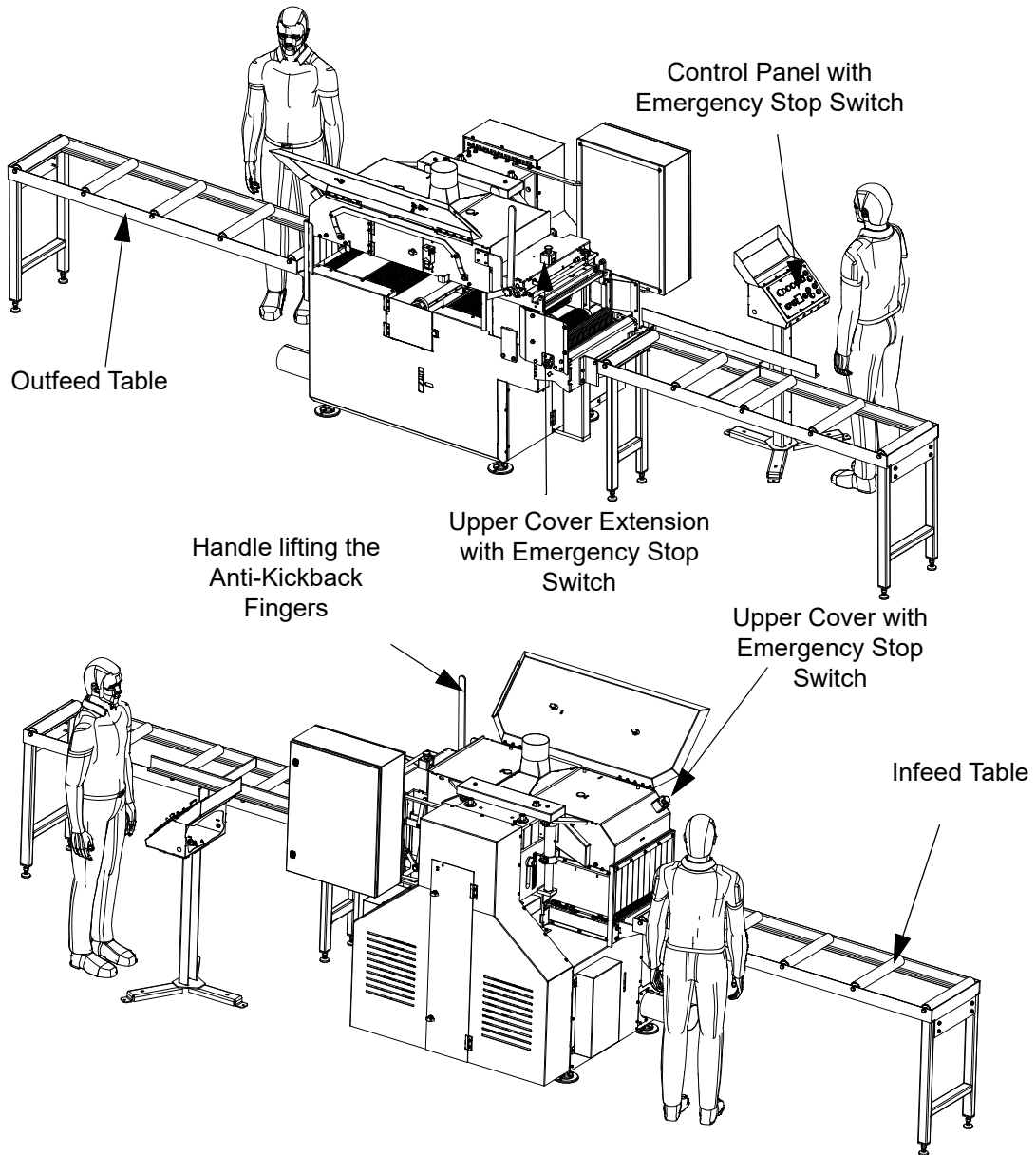

**RYS. 2-2 MR200**

**Emergency Procedure**



In case of accident or machine failure:

- Immediately switch the machine off and disconnect the power supply
- Give first aid to injured persons
- Secure the place of the accident. (Leave the machine and workplace without changes)
- Report the accident or machine failure to superior or OHS inspector
- Leave the information on the machine: OUT OF ORDER, DO NOT START

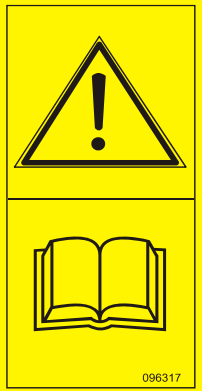

**Safety Labels Description**

**See table 2-1** See the table below for descriptions of the safety labels placed on the machine.

**TABLE 2-1**



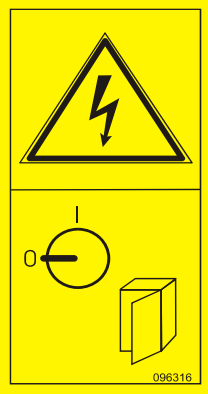
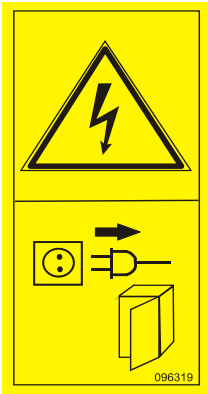

Decal View	Decal No.	Description
	096317	CAUTION! Read thoroughly the operator's manual before operating the Multi Saw. Observe all safety instructions and rules when operating the machine.
	099220	Close all guards and covers before starting the machine.

**TABLE 2-1**



	<p>096316</p>	<p>Do not open or close the electric box when the switch <b>is not</b> in the "0" position.</p>
	<p>096319</p>	<p>Always disconnect the power cord before opening the electric box.</p>
	<p>099540</p>	<p>CAUTION! Toothed gear - keep persons away!</p>
	<p>S12004G</p>	<p>Always wear safety goggles when operating the Multi Saw.</p>



**TABLE 2-1**

	S12005G	Always wear protective ear muffs when operating the Multi Saw.
	501465	CAUTION! Always wear safety boots when operating the Multi Saw!
	510080	CAUTION! Always wear protective gloves when operating the Multi Saw.
	539211	Always wear protective apron when operating the Multi Saw.
	501467	Lubrication point

**TABLE 2-1**

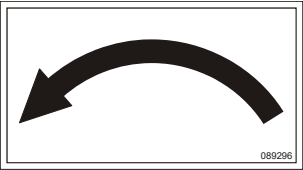
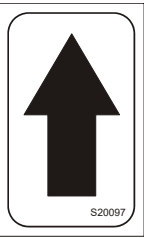
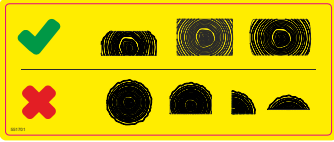
	<p>099504</p>	<p>Visible and/or invisible laser radiation. Avoid eye or skin exposure to direct or scattered radiation.</p>
	<p>P85070</p>	<p>CE safety certification</p>
	<p>089296</p>	<p>Rotation direction</p>
	<p>S20097</p>	<p>Motor rotation direction.</p>
	<p>551701</p>	<p>Allowable and non-allowable shapes of sawn material</p>

## SECTION 3 MACHINE OPERATION

See Figure 3-1

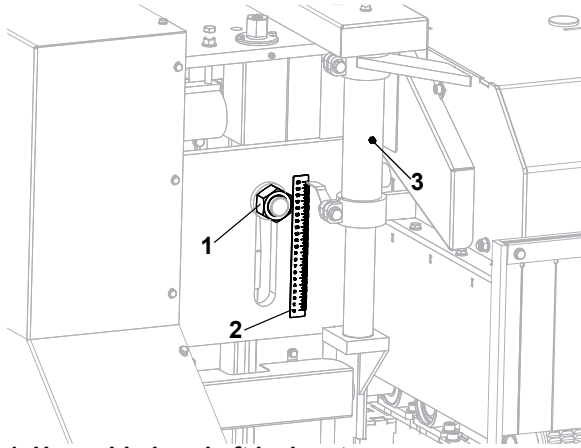

- 1. Upper blades shaft lock nut
- 2. Cut material thickness scale
- 3. Clamp box grease

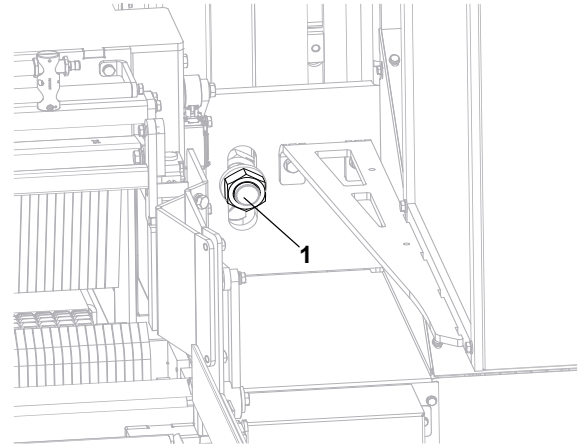

- 1. Lower blades shaft lock nut

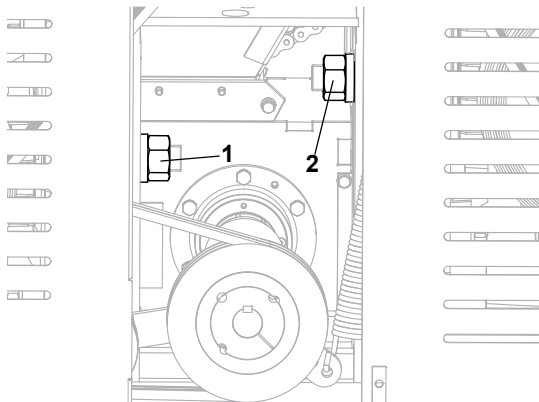

- 1. Lower blades shaft motor lock nut
- 2. Upper blades shaft motor lock nut

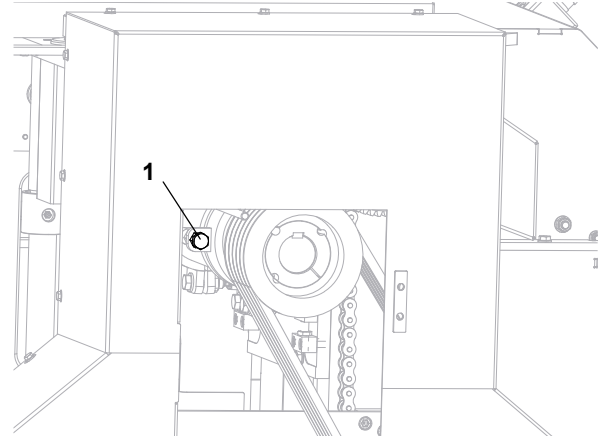

- 1. Upper blades shaft vertical adjustment bolt

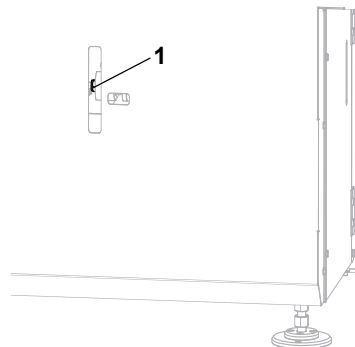

- 1. Upper chain tensioner nut

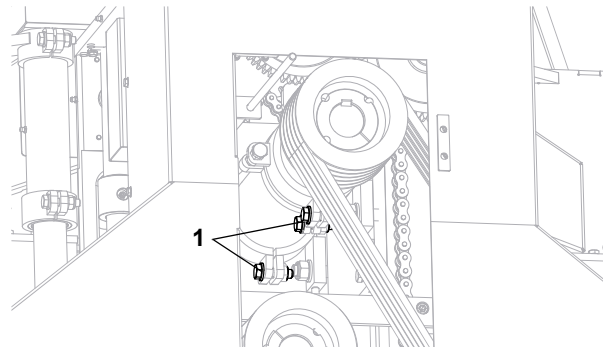

- 1. Upper blades shaft bracket bolts

FIG. 3-1

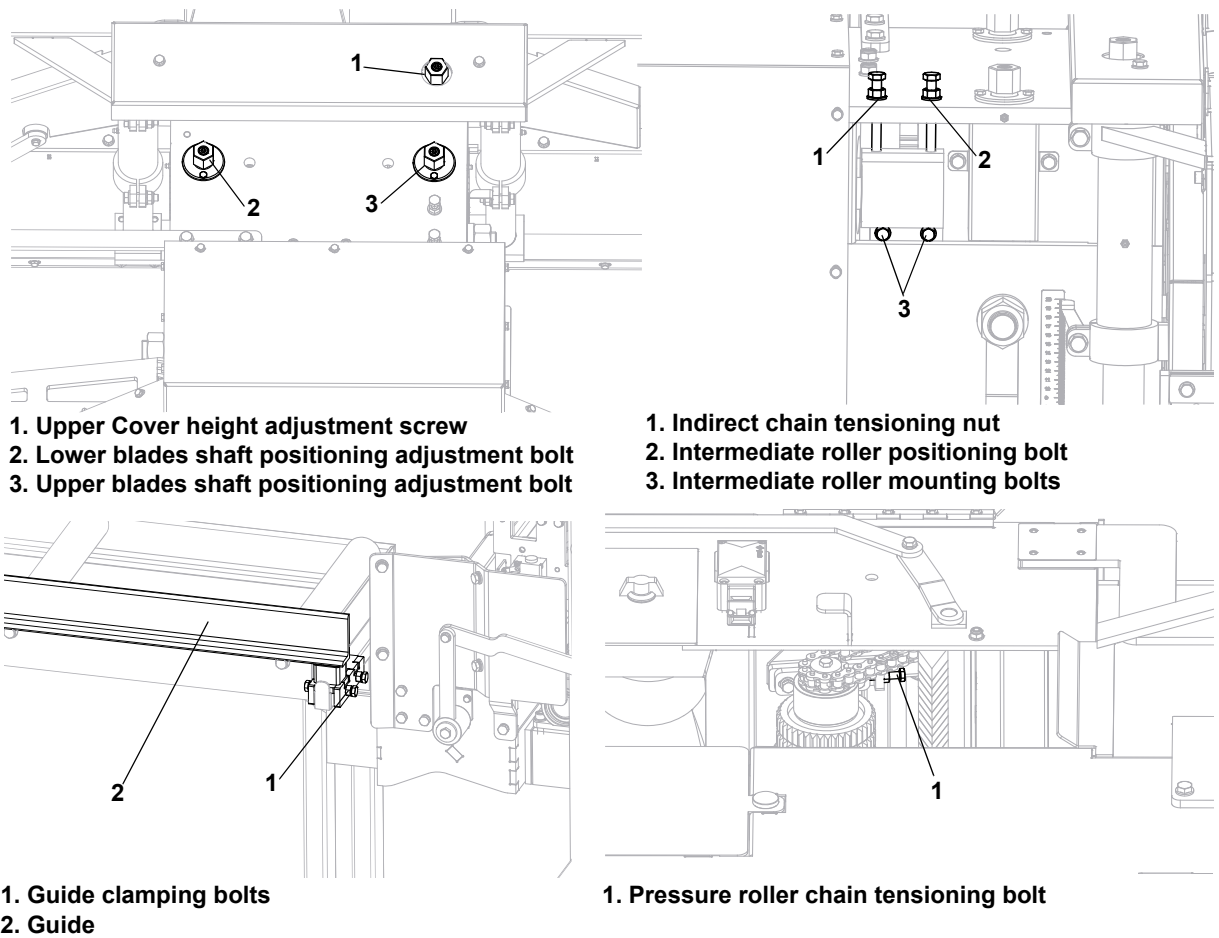

FIG. 3-1

### 3.1 Intended Use

The multi saw machine type MR200 is used to cut boards and slats from prisms. Boards and slats thickness depends on spacers used between the saws. The multi saw machine is intended for sawing wood only. Cutting other materials is forbidden. The machine may be used in small, medium and even big wood processing industrial facilities.

### 3.2 Construction

Multi Saw Machine type MR200 consist of welded structural sections (body), upper clamp mechanism, infeed tunnel and protective guards.

Frame includes two segments welded to each other.

One of the segments is a main frame made of 350 mm channel bar and 18 mm steel sheet. Two blades shafts motors and two "floating" blades shafts with positioning mechanisms.

The other segment is made of 100 mm channel bar and it is a bearing base for five lower feed rollers and one row of anti-kickback fingers.

The upper clamp assembly consists of drive components, two clamping rollers, feed rollers positioning assembly, two rows of anti-kickback fingers and housing.

Board enter cover is bolted to the frame and it has two rows of anti-kickback fingers together with lifting handle and a frame that limits cut material height and width.

Protective covers:

- Transmission belts cover
- Feed rollers drive cover
- Blades shafts cover

### 3.3 Operation

To have large cutting height (200 mm) two blades shafts one over another are used. They are perpendicularly displaced one to the other. Both blades shafts are mounted on supports and they can be adjusted vertically. This allows to use two saws with different diameter (200 mm to 315 mm) depends on cut material thickness an also to adjust blades shafts that two motors are equally loaded. Clamp assembly consists of five lower rollers (fixed) and two upper rollers (lifted) with drive transmitted from motoreducer using chains and gears. Over the first lower roller there is a small pressure roller that allows feeding cut material.

Upper roller clamp adjustment - manually adjusted depending on cut material thickness.

### 3.4 Transport

Multi Saw is factory aligned. Use forklift or overhead crane (lifting capacity min 2500kg) to load or unload the machine. Minimum length of the forks - 2 meters. Slide the forks under the machine in places shown below.

See Figure 3-2

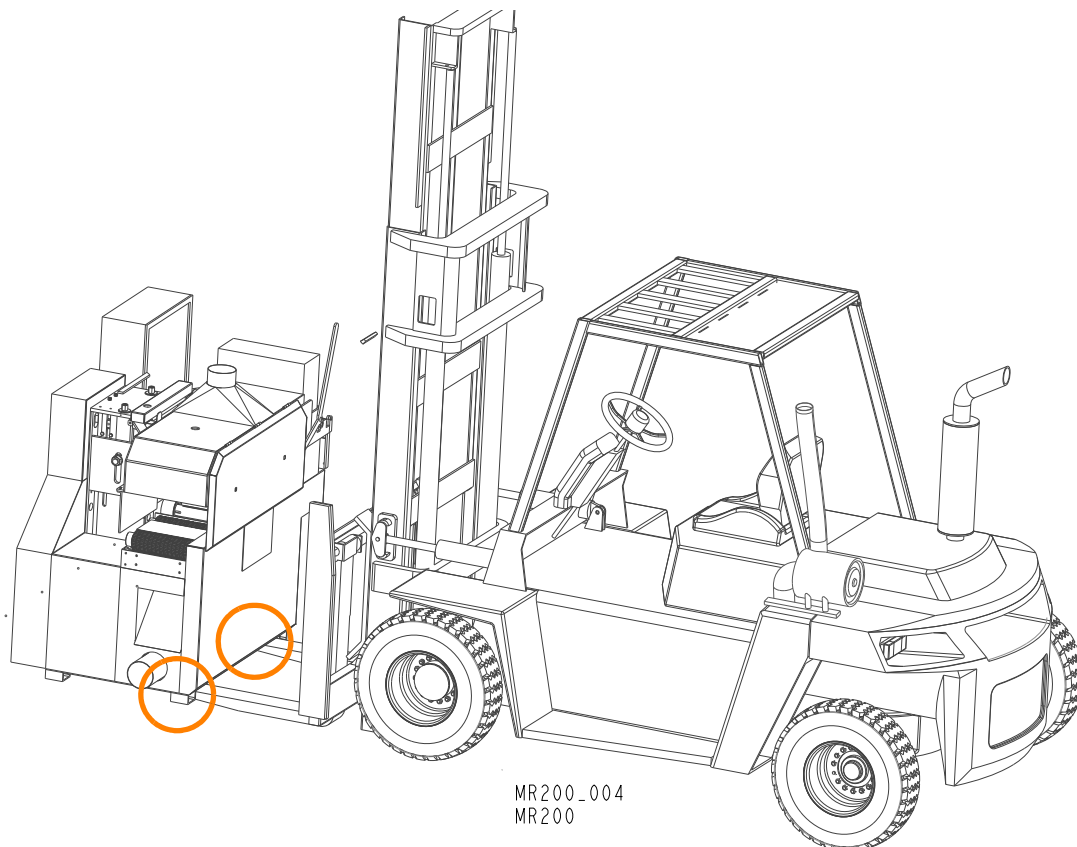

FIG. 3-2 MR200

### 3.5 Machine Installation

#### *Set up the machine*

Set up the Multi Saw on firm ground under roof (in screened place) or indoors.

Level the machine using the level ( $\sim 0,1/100\text{mm}$ ) The measurement should be taken on the working table in lateral and lengthwise directions. The machine has four feet with holes for bolts which anchored the machine to the floor.

## Connection to power supply system

Connect the machine to power supply system (3x400V, 50 Hz), using a conductor with polyvinyl insulation. The ground wire should be yellow-green colour.

Connect the wires to the L1, L2, L3, N, PE clamps located in control box.

Before power supply connection:

- Compatibility between machine electric system and power supply system in the workplace. Check working voltage and current frequency.
- Check electrical installation according to electrical diagram for given power supply voltage.
- Check electrical installation was not damaged during transportation. Replace damaged parts immediately. Inspect all wire connections. If it is necessary, tighten corresponding set screws.
- Inspect motor insulation condition (if it is not moistened), using the inductor with the 500V voltage. Measure the insulation resistance for each circuit and at the end for the entire frame of the machine.
- Depending on the supply conditions, measure the efficiency of fire protection.
- Route the supplying wires in accordance with safety rules.
- Have a qualified electrician install the power supply (according to EN 60204 Standard).



**IMPORTANT!** For correct machine electric devices operation, power supply voltage during motor start and the machine operation must be within  $\pm 10\%$  of the rated voltage.



**IMPORTANT!** It is required that a 30mA Ground Fault Interrupter (GFI) be used.

## Recommendations for the preliminary start-up the Multi Saw

Before start-up the machine read this manual, especially section IV. When all recommendations are met the Multi Saw can be started (idle run). The idle run should last about 1 hour. If during this time blades shafts bearings do not overheat, the test run is successful.

Before starting the work it is required to:

- Remove all wooden transport blocks located inside the machine.
- Install required number of saws with suitable spacer bushings (both blades shafts should be equal).
- Use special wrenches to tighten circular saws and spacers.
- Set the distance between upper and lower saws (min. 2mm). To do this, use the special wrench 46 to loosen blades shaft mounting nuts and motor locking nuts. Make the adjustment with special wrench 30 mm. When adjustment is finished, tighten the nuts.

- Use 30 mm special wrench to set the upper feed rollers in correct position, depending on cut material thickness. The feed rollers should be about 10 mm under the cut material top surface (use the scale located on the support to set the cut material thickness).
- Connect the machine to the extractor system with the capacity about 2900m<sup>3</sup>/h. The machine has two extraction pipes with 150 mm diameter.
- Illuminance at operator's position must be 300lx.<sup>1</sup>



**CAUTION!** Do not set the upper feed rollers more than 15 mm below the cut material top surface. Failure to do so may result in machine damage.

---

<sup>1</sup> The light source can not cause stroboscopic effect.



## 3.6 Multi Saw operation

### Start up

Before starting the work, choose the proper saw diameter depending on cut material thickness, to make it possible to cut selected material thickness plus additional min. 20 mm. Next, make the machine adjustment and alignment according to Section 8 of this manual. Adjust the clamp in position suitable for cut material thickness (use the scale - fig. 2, item 18). To do this put the 30mm special wrench on the roller clamp adjustment bolt (fig. 2 item 16). The machine is equipped with cut material guide, which may be used on the bed (fig. 1 item 1) and fixed in proper position with clamp bolt. The guide must be parallel to the saws. To adjust the guide, loosen the front bolt located on the left side of the bed (fig. 1 item 2) and set the bed in correct position (guide plate and saws should be parallel). Tighten the front bolt.

When the guide plate is not used the bottom blades shaft bearing sleeve should be at the same height or lower than the feed rollers in the machine table. The Multi Saw can be equipped with infeed and outfeed tables, which make material feeding and off-bearing easier.

### MR 200 control panel for CE market

See Figure 3-3

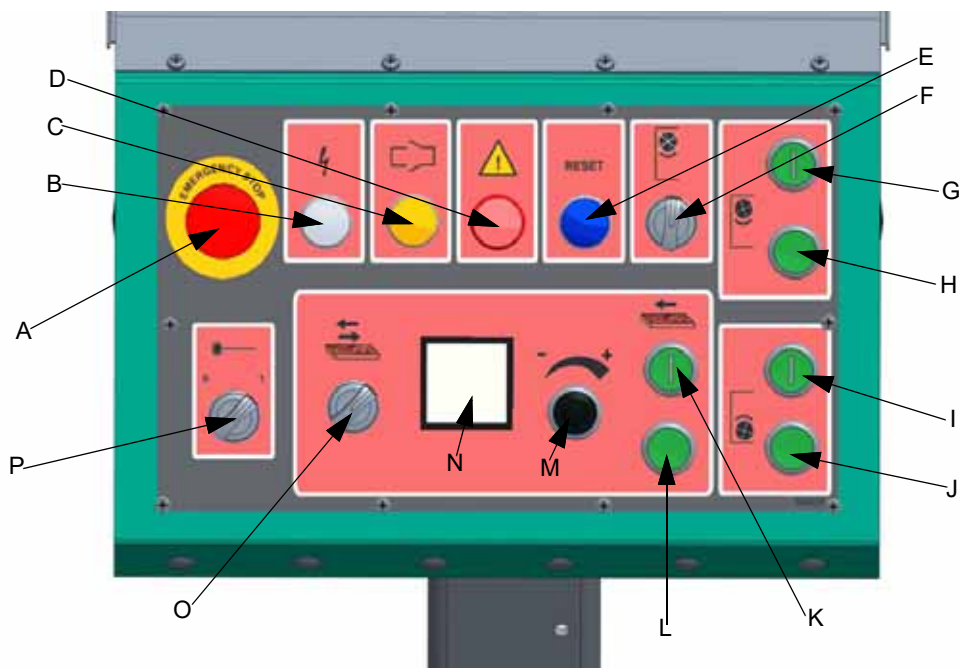

FIG. 3-3

A - Safety Switch.

B - "Power On" light.

C - "Covers Lock" light.

D - "Emergency" light.

E - "Reset" button.

F - Upper blades shaft lock switch.

G - "START - UPPER DRIVE" button. Turns on the drive of the upper blades shaft.

H - "STOP - UPPER DRIVE" button. Turns off the drive of the upper blades shaft.

I - "START - LOWER DRIVE" button. Turns on the drive of the lower blades shaft.

J - "STOP - LOWER DRIVE" button. Turns off the drive of the lower blades shaft.

K - "FEED-ON" switch.

L - "FEED STOP" switch.

M - Feed speed potentiometer.

N - Feed speed indicator, in meters per minute.

O - "FORWARDS/BACKWARDS feed" switch

P - Laser indicator switch.

Check electric shock protection before first start of the machine and after each reconnection power to the machine. When the saws are mounted and the machine is properly adjusted:

- Check if covers are properly mounted and control switches location.
- Open the padlock on the main switch.
- Turn the main switch on (POWER ON light is on).
- If the "EMERGENCY" (D) light is on check emergency switches located on the control box and on the frame. Also check if covers are properly mounted and motor overload switches are not tripped. If red light is still on, reset the covers interlock using "RESET" button (E). The red light is off when all control and protection elements are in proper position.
- Use START-LOWER DRIVE (I) and START-UPPER DRIVE (G) buttons to start blades shafts.
- With the feed speed control potentiometer (M), set the desired feed speed. If the feed motor is too loaded, the feed speed will be automatically decreased.
- Set the FORWARD/BACKWARD (O) switch in FORWARD position.
- The feed is switched on using the feed-on button (K). Forward feed can only be engaged when both shaft drives are engaged or when the upper shaft drive is locked with the upper shaft lock switch (F).

- Use the FEED STOP switch to stop the feed (L).



**CAUTION!** The feed direction may be changed when feed rollers are stopped. It is possible to start the feed backward when blades shaft drive is off and anti-kickback fingers are lifted. To do this set the FORWARD/BACKWARD switch in BACKWARD position and pressing the switch FEED START.

### MR 200 Control Panel

See Figure 3-4

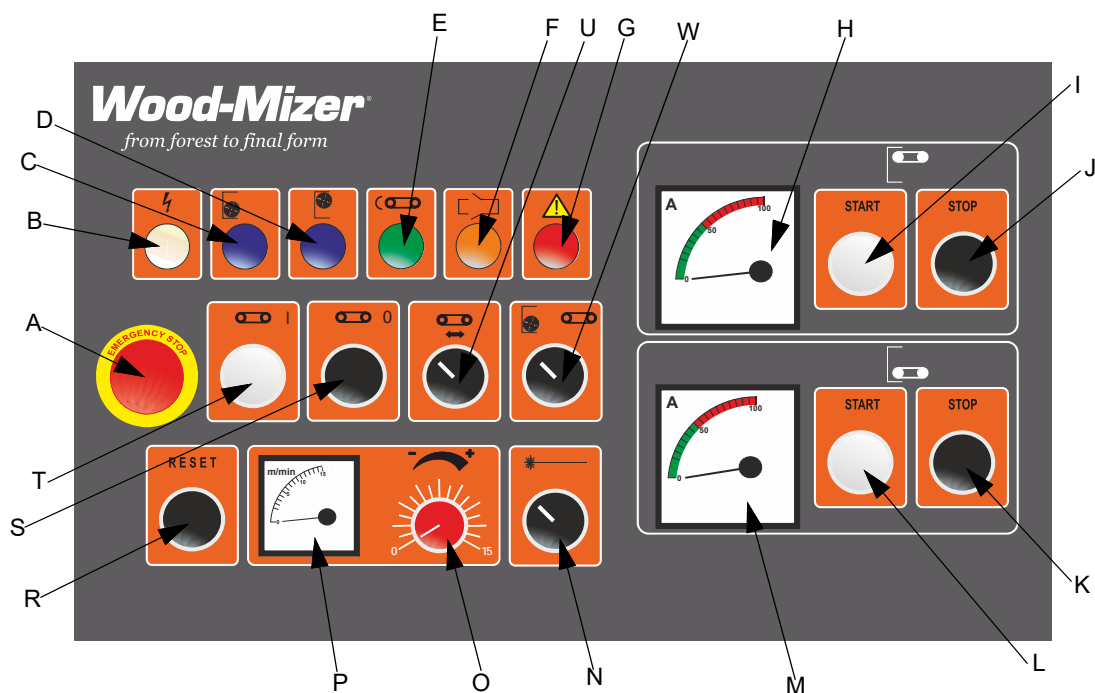

FIG. 3-4

- A - Safety Switch.
- B - "Power On" light.
- C - A light indicating the operation of the lower blades shaft.
- D - A light indicating the operation of the upper blades shaft.
- E - A light indicating the operation of the feed.
- F - "Covers Lock" light.
- G - "Emergency" light.
- H - Upper blades shaft drive ammeter.

I - "START - UPPER DRIVE" button. Turns on the drive of the upper blades shaft.

J - "STOP - UPPER DRIVE" button. Turns off the drive of the upper blades shaft.

K - "STOP - LOWER DRIVE" button. Turns off the drive of the lower blades shaft.

L - "START - LOWER DRIVE" button. Turns on the drive of the lower blades shaft.

M - Lower blades shaft drive ammeter.

N - Laser indicator switch.

O - Feed speed potentiometer.

P - Feed speed indicator, in meters per minute.

R - "Reset" button.

S - "FEED STOP" switch.

T - "FEED-ON" switch.

U - "FORWARDS/BACKWARDS feed" switch

W - Upper blades shaft lock switch.

Check electric shock protection before first start of the machine and after each reconnection power to the machine. When the saws are mounted and the machine is properly adjusted:

- Check if covers are properly mounted and control switches location.
- Open the padlock on the main switch.
- Turn the main switch on (POWER ON light is on).
- If the "EMERGENCY" (G) light is on check emergency switches located on the control box and on the frame. Also check if covers are properly mounted and motor overload switches are not tripped. If red light is still on, reset the covers interlock using "RESET" button (R). The red light is off when all control and protection elements are in proper position.
- Use START-LOWER DRIVE (L) and START-UPPER DRIVE (I) buttons to start blades shafts.
- With the feed speed control potentiometer (O), set the desired feed speed. If the feed motor is too loaded, the feed speed will be automatically decreased.
- Set the FORWARD/BACKWARD (U) switch in FORWARD position.
- The feed is switched on using the feed-on button (T). Forward feed can only be engaged when both shaft drives are engaged or when the upper shaft drive is locked with the upper shaft lock switch (W).

- Use the FEED STOP switch to stop the feed (L).



**CAUTION!** The feed direction may be changed when feed rollers are stopped. It is possible to start the feed backward when blades shaft drive is off and anti-kickback fingers are lifted. To do this set the FORWARD/BACKWARD switch in BACKWARD position and pressing the switch FEED START.

## Operation

Multi Saw should be operated with at least 3 persons: One person feed the material to board enter cove and operate the control pane. Two persons receiving the sawed material, should be next to outfeed table. All of them should stay at the left side of the machine.

Only persons who have read and understood the entire operator's manual and were trained in OHS rules should operate the Multi Saw. The machine should be operated only if all its kinematic system works properly.

It is not allowed to operate the machine without covers and it is forbidden to make any adjustments when the machine drives are on. Do not use the machine without the chip extraction system connected. Two ammeters for blades shafts motors are located on control box and allows to constant control machine load.

Pay particular attention for operators' safety. Observe all safety instructions also these included in this manual. Maintain a clean and clear path for all necessary movement around the Multi Saw. Correctly stack all cut material and any sawing by-products generated during processing. To ensure correct cutting, the material to be cut must be properly prepared (has to get equal height, straight and parallel surfaces and be free of impurities (soil, sand, foreign matters e.g. nails, chips etc.).



**IMPORTANT!** Only one workpiece can be feed to the machine at the same time. Cutting cracked wood, with fuzzy grain or faces that are not straight or not correctly cleaned from branches may result in damage to the saws and lower extraction pipe can be blocked too fast.



**CAUTION!** Side guards are mounted with screws and protected against accidental opening with interlocked limit switches connected to tachometer. It allows to open the side guards only when blades shafts are completely stopped. If limit switches not work properly, immediately stop the machine operation until the problem is corrected. Few times a day control the anti-kickback fingers, especially when cutting wood with a high resin content. If it is necessary, stop the work, clean anti-kickback fingers from resin and other debris, lubricate them (aerosol will be the best). If anti-kickback fingers work properly, back to work.

***Machine stopping***

To stop the Multi Saw:

- Stop the feed using “FEED STOP” button
- Press the “STOP-LOWER DRIVE” button (pressing only STOP-UPPER DRIVE button will stop only upper blades shaft).
- Pushing the emergency switch (red knob) will stop the machine.
- Turn the MAIN SWITCH to 0 position
- In case of emergency, stop the machine using emergency switch (red knob) located on control panel and on the machine frame on the outfeed side.



**CAUTION!** Engage the feed forward and check feed rollers rotation direction. If the rotation direction is incorrect, invert the phases in the phase inverter in the power socket. When sawing is finished, shut down the machine and padlock the control box.

## SECTION 4 MAINTENANCE AND ALIGNMENT

### 4.1 Tools:

- Blades shaft nut driver
- 46 mm Blades Shaft special wrench
- 30 mm Special wrench for supports and clamp roller adjustment
- 46 mm Flat wrench (motors and supports blocking)
- 19 mm Special wrench
- 18 mm Special wrench

### 4.2 Maintenance

Every day clean the machine from to remove sawdust and chips, Every 12 month lubricate all chains submerging them in heated oil with graphite grease. Once a month use Łt13 grease to lubricate tensioner hinge, clamp assembly bolts, support bolts and clamp guides.

There are seven lubrication points. Two lubrication points: support bearing adjustment bolts lubrication; two lubrication points: clamping cover bolts lubrication; two lubrication points: clamping cover guide rails lubrication; one lubrication point: on upper intermediate chain tensioner hinge. Use grease to lubricate these points once a month or more often if needed.

### 4.3 Multi Saw adjustment

#### ***Blades Shaft axis vertical alignment is made at the factory***

There is no need to align it during machine operation. Readjustment of the blades shafts alignment may be required at the significant wear of the machine or if the blades shaft brackets were removed from the machine.

#### ***Aligning the upper to lower blades shafts in one cutting plane***

To achieve cutting in one plane for upper and lower saws, the upper blades shaft must be aligned to the lower one through the open door on the pulleys side. To do this, loosen the upper blades shaft bracket bolts and use the adjustment bolt to move the upper blades shaft in required direction until the upper saws will be exactly in the same plane as corresponding lower saws. After adjustment, retighten shaft bracket bolts.

#### ***Setting the blades shafts position depending on the workpiece thickness***

The Multi Saw has two “floating” blades shafts that allow stead loading of the two motors, independently on the workpiece thickness. First it is required to select the saw diameter suitable to the workpiece thickness, which must ensure cutting at least half of the workpiece thickness plus 10 mm. When the selected saw diameter ensures cutting for more than half of the workpiece thickness plus 10 mm, the lower blades shaft must be lowered to allow cutting half of the desired thickness. To do this, use the plat wrench 46mm to loosen the lower blades shaft lock nut and motor lock nut. Next,

use the special wrench 30 mm on the adjustment bolt to lower or rise motor and the lower blades shaft to the desired height.

Tighten previously loosened nuts. The saws must be mounted according to section “**Mounting the saws on the shafts**”. Next, set the upper blades shaft in the correct position. Adjust the upper blades shaft position in the same way as the lower blades shaft, to such position that the material will be cut at full thickness. Be sure that the distance between upper saw teeth top and the lower saw teeth top should be at least 2 mm. Too large distance between upper and lower saws may cause that the cut is too short.



**CAUTION!** During vertical adjustment of the blades shafts, pay particular attention not to cause that the upper and lower saws teeth hit each other, as it will damage the saws.

### **Mounting the saws on the shaft**

Before mounting the saws prepare the shafts, saws, spacers and if necessary saw sleeves cleaning them carefully from dust and other impurities. Select suitable saw, depending on cut material thickness. Minimal saw diameter is 200 mm and maximal - 315 mm. Mount the saws set with spacers on the blades shafts or sleeves and after the last saw mount spacer/s to fill not threaded part of the blades shafts or sleeves. Next, use the special wrenches to tighten saws on the shafts or sleeves. In machines with the saw sleeves mount the saw on the sleeves in the workshop using the tool with vise to fix the saws.



**CAUTION!** Make sure that nuts on the blades shafts are properly tightened. Too loose nuts tightening may cause serious damage to shafts and saws.

Top blade shaft nuts are right hand thread and bottom blade shaft nuts are left hand thread.

In a single set use only saws with the same parameters and which meet the requirements of EN847-1:1997 Standard (1 set is a set of lower and upper shaft saws). It is recommended to use saws in a single set not only with the same parameters but also from the same producer and with the same degree of wear.



### Blades Shaft drive V-belts tensioning

- Before tensioning the lower shaft drive V-belts, remove the lower shaft support nut cover with the engine support (A). This is not necessary for tensioning the upper shaft drive V-belts.

See figure 4-1

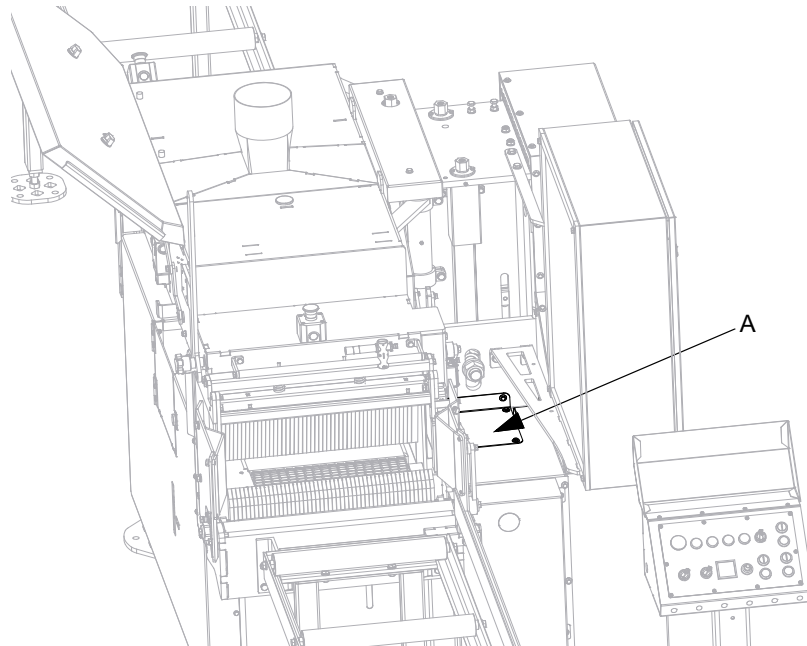

FIG. 4-1

- To tension the V-belts, loosen the motor lock nuts (B) and then loosen the lock nuts on the shaft supports (C), as a result of which the belts will be tightened due to the weight of the engine (by gravity). Once the belts are tightened, tighten the previously loosened nuts and install the motor cover.

See figure 4-2

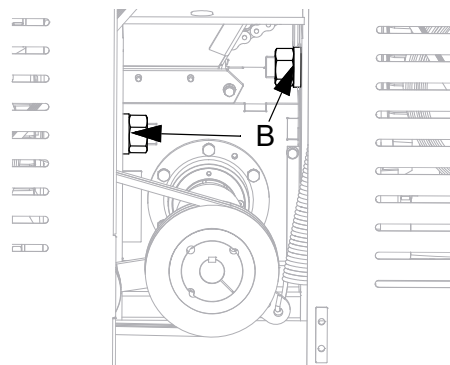
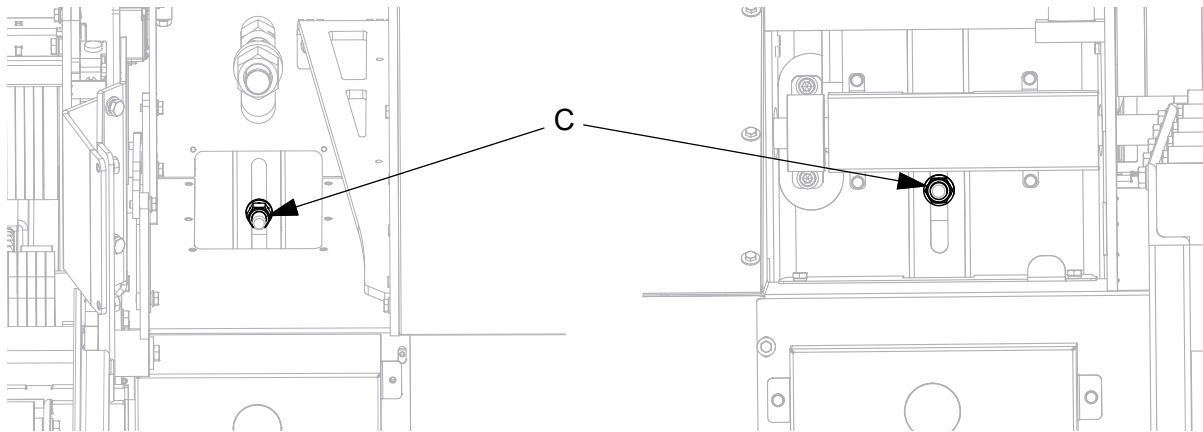

FIG. 4-2

See figure 4-3



**FIG. 4-3**

- After tensioning the shaft drive V-belts, tighten the chipper V-belts with the adjusting screw (D).

See figure 4-4

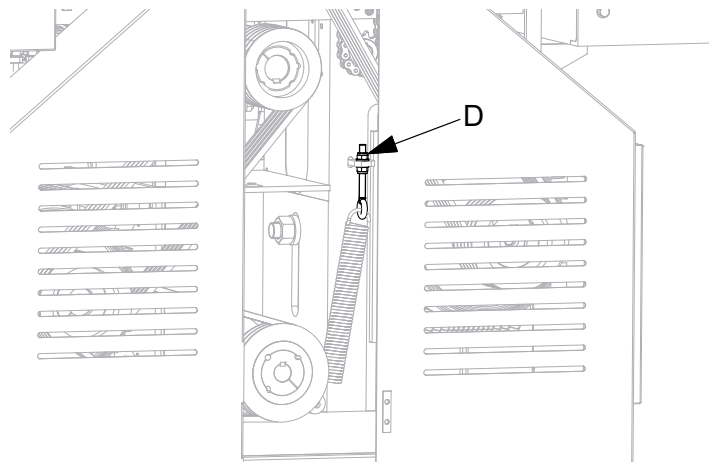

**FIG. 4-4**

- V-belt tension should be checked at the center of the distance between the pulleys. Data needed to check the tension of each belt are given in the table below:

See Table 4-1

	Force	V-belt deflection
Lower blades shaft V-belt	1400N	15mm
Upper blades shaft V-belt	3000N	30mm
Chipper V-belt	1700N	18mm

**TABLE 4-1**

### ***Feed roller chains tensioning***

Check the chain tension of the chain drive after every 100 hours of operation. There are five chains on the machine. If they are overtensioned, it is necessary to tension the chains properly.

- a) Feed drive main chain.
- b) Feed drive indirect chain.
- c) Upper feed roller drive chain - indirect.
- d) Infeed feed roller drive chain.
- e) Outfeed feed roller drive chain.

Feed drive main chain - To tension the main chain, using the hole in the lower front cover with a 19mm wrench, tighten the nut (A) until the correct gap between the bushings (B) is achieved (max: 15mm, min: 3mm).

**See figure 4-5**

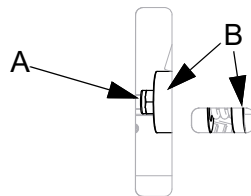

**FIG. 4-5**

Feed drive indirect chain - Open the belt guard door to gain access to the chain. Loosen the intermediate shaft mounting bolts (A) and then tighten the chain with the M10 nut (B), while using the M10 bolt (C) from the right side to make the alignment of the intermediate shaft level. After obtaining acceptable adjustment results, tighten the intermediate shaft fixing screws strongly.

See figure 4-6

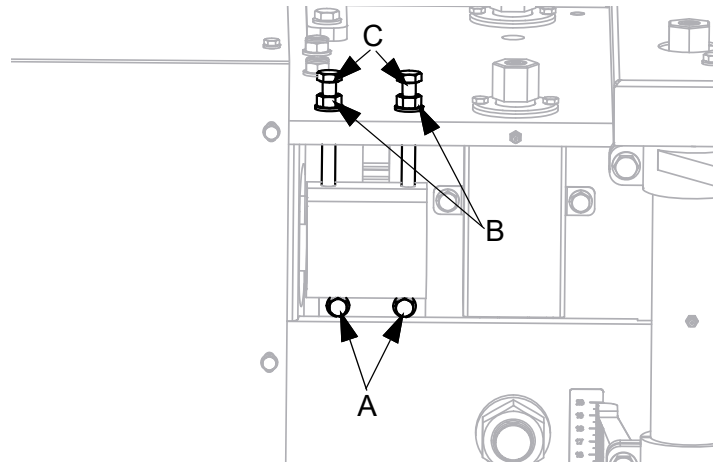
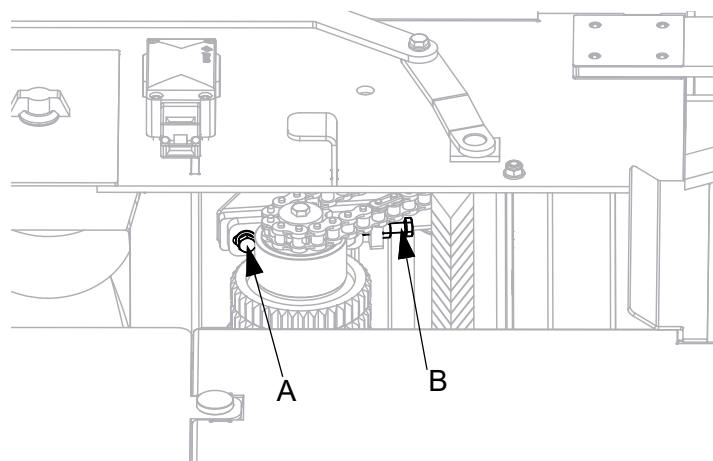

**FIG. 4-6**

Upper feed roller drive chain (indirect) - this chain does not need to be tensioned. If the chain is overtensioned or worn, shorten the chain or replace it for the new one.

Infeed and outfeed feed roller drive chain - Loosen the fastening bolts of the upper feed rollers (A) and use the tensioning bolts (B) to make the correct chain tension evenly on both sides, after the chain is tensioned, the adjusting bolts should be locked and the loosened fastening bolts tightened.

See figure 4-7



**FIG. 4-7**



**CAUTION!** Do not overtension the chains and do not work with too loose chains can cause excessive chains and sprockets wear and may result in serious damage the machine.

## Guide

The machine is equipped with a guide for the cutting material (A), which has a sliding mechanism along the axis of the shafts as needed. Before starting work with the guide, it is necessary to set it in a line parallel to the plane of the blades using M10 screws (B) located in the face of the guide bracket. It is possible to work on the machine without using the guide, but only if the lower shaft is in the lowered position to such an extent that its bearing housing (bearing sleeve) is at an equal or lower height as the lower drawing rollers.

See figure 4-8

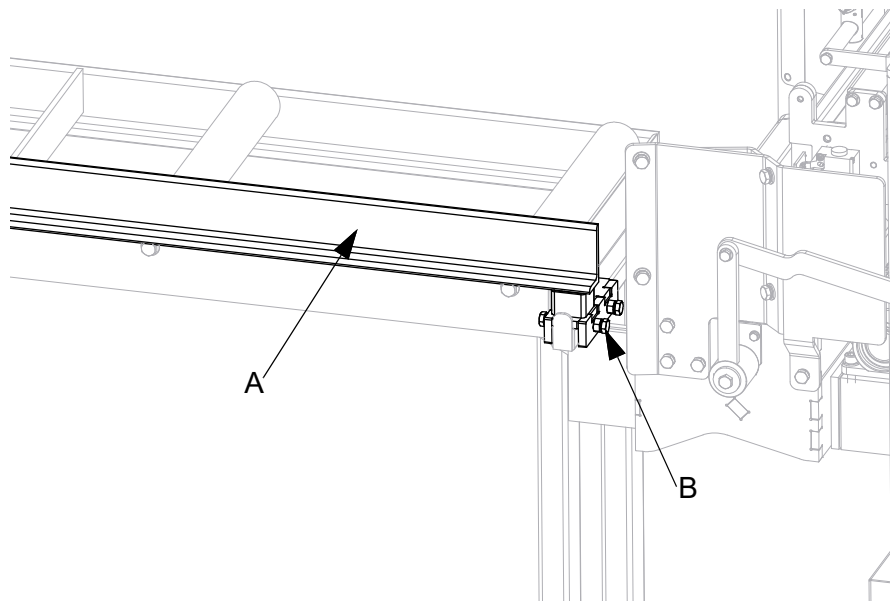

FIG. 4-8

## 4.4 Chipper

The Multi Saw is equipped with chipper located directly below lower saw spindle. Chipper crushes wood byproducts, which together with sawdust are removed through the lower sawdust removal pipe.

This prevents sawdust chute impeller vanes damage and getting blocked of sawdust removal pipe.

Once a month lubricate the V-belts tensioner hinge with grease (e.g. Łt-43) using the oiler.

When knives are dull, dismount them and change their positions so the sharp edge replace dull one. Distance between fixed knife and knives mounted on cutter should be 0.1-0.2 mm. Remember to retighten all knives mounting bolts securely to avoid moving the knife and damage to the machine.



**CAUTION!** Before starting the machine inspect the chipper for wood chips or other objects which can stuck the cutter. Pay particular attention not to let any object, especially a metal one, such as a key, spacers, etc., get into the chipper while the machine is working, because it may seriously damage the machine.

To ensure proper chipper operation, capacity of the chip extraction system must be about 3600 m<sup>3</sup>/h.

## 4.5 Safety Devices Inspection (Only CE Version<sup>1</sup>)

### MR200 Multi Saw Safety Devices Inspection

See figure 4-9

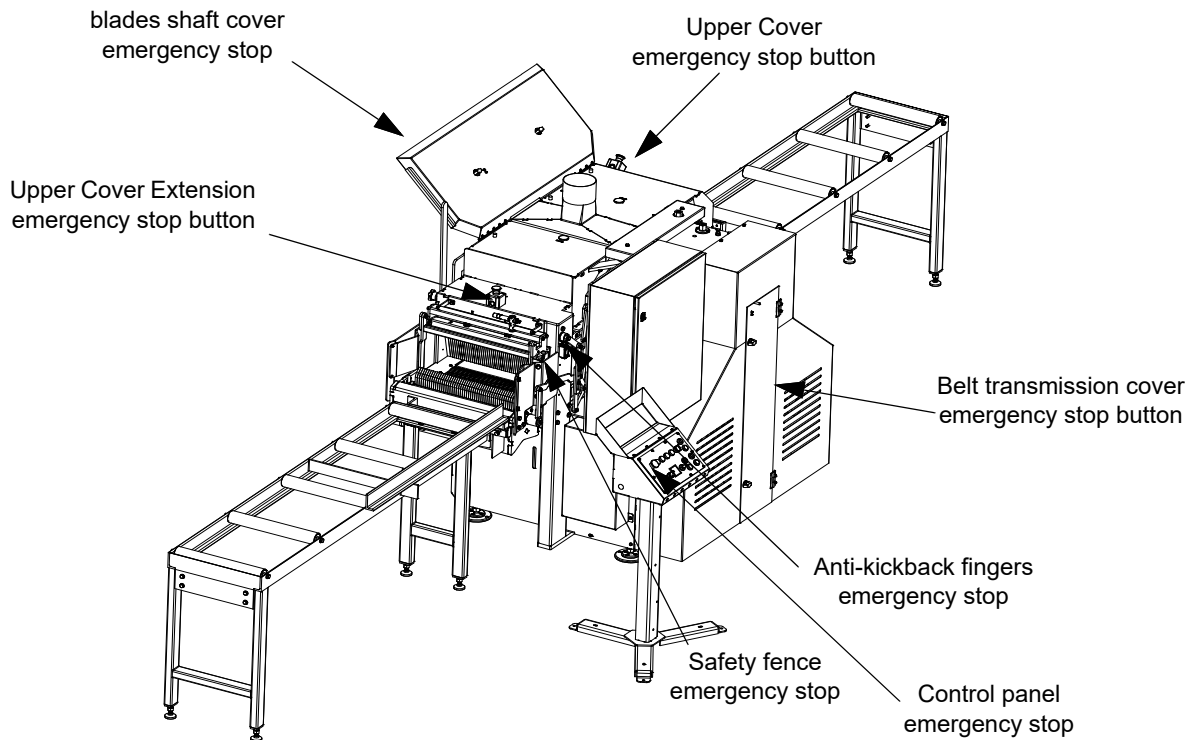

FIG. 4-9

Before beginning a shift, inspect the following safety devices of the MR200 Multi Saw:

- E-Stop button circuit - control box
- E-Stop button circuit - upper cover
- E-Stop button circuit - upper cover extension
- E-Stop button circuit - safety fence
- E-Stop button circuit - anti-kickback fingers
- E-Stop button circuit - belt transmission

<sup>1</sup> Marking of products sold within European Economic Area

- E-Stop button circuit - blades shaft cover

### **1 Inspecting the E-Stop button circuit - Control Panel**

- Start the main motor.
- Press the emergency stop button located on the control box. The motor should be stopped. It should not be possible to restart the motor until the E-STOP button is released.

### **2 Inspecting the E-Stop button circuit - Upper Cover**

- Start the main motor.
- Press the emergency stop button located on the upper cover. The motor should be stopped. It should not be possible to restart the motor until the E-STOP button is released.

### **3 Inspecting the E-Stop button circuit - Upper Cover Extension**

- Start the main motor.
- Press the emergency stop button located on the upper cover extension. The motor should be stopped. It should not be possible to restart the motor until the E-STOP button is released.

### **4 Inspecting the E-Stop button circuit - Security Fence**

- Start the main motor.
- Use board to push the safety fence
- The motor should be stopped.
- To start the motor, press the START button. It should not be possible to start the motor.
- Move the board back.
- The motor power feed should remain stopped.

### **5 Inspecting the E-Stop button circuit - Anti-kickback fingers**

- Open the cover on the saw side.
- Elevate the recoil anti-kickback fingers lever.



- Reset the safety circuit with the RESET button.
- To start the motor, press the START button. It should not be possible to start the motor.

#### **6 Inspecting the E-Stop button circuit - Belt transmission cover**

- Start the main motor.
- Try to open the belt transmission cover - the solenoid lock should prevent it from opening.
- Stop the main motor.
- After the blades shafts stop, open the cover of the belt transmission.
- To start the motor, press the START button. It should not be possible to start the motor.
- Close the belt transmission cover.
- The motor should remain stopped.

#### **7 Inspecting the E-Stop button circuit - blades shaft cover**

- Start the main motor.
- Try to open the blades shafts cover - the solenoid lock should prevent it from opening.
- Stop the main motor.
- After the blades shafts stop, open the cover of the belt transmission.
- To start the motor, press the START button. It should not be possible to start the motor.
- Close the blades shaft cover.
- The motor should remain stopped.

## SECTION 5 SPECIFICATIONS

### 5.1 MR200 Multi Saw Overall Dimensions

See Table 5-1 The overall dimensions are listed in the table below.

<b>Weight</b>	2000 kg
<b>Height</b>	1800 mm
<b>Width</b>	1100 mm 1120 mm (2x37 kW version)
<b>Length</b>	1400 mm

**TABLE 5-1**

### 5.2 MR200 Multi Saw Specifications

See Table 5-2 See the table below for technical data on the MR200.

	<b>Motor Specifications</b>
<b>Saw drive motor voltage and power</b>	3x400V 50Hz 3x230V 50Hz  2x15kW 2x18, kW 2x22 kW 2x30 kW 2x37 kW
<b>Saw drive motor rotational speed</b>	2900 r.p.m. at 50Hz
<b>Shaft with saws rotational speed:</b>	3600 r.p.m. at 50Hz
<b>Feed drive motor voltage and power</b>	3x400V 50Hz 1,5 kW
<b>Feed drive motor rotational speed</b>	1450 r.p.m. at 50Hz
<b>Linear feed speed</b>	1.5-15m/min

**TABLE 5-2**

See Table 5-3 Saws and cut material specifications

	Specifications
Circular saw diameter	200-315mm
Blades shaft diameter	60mm
Maximum number of circular saws	10 pcs per shaft
Maximum material height	200mm
Minimum material height	30mm
Maximum material width	540mm
Cutting Capacity	Up to 10m <sup>3</sup> /h

**TABLE 5-3**

See Figure 5-1 Allowable and non-allowable shapes of sawn material

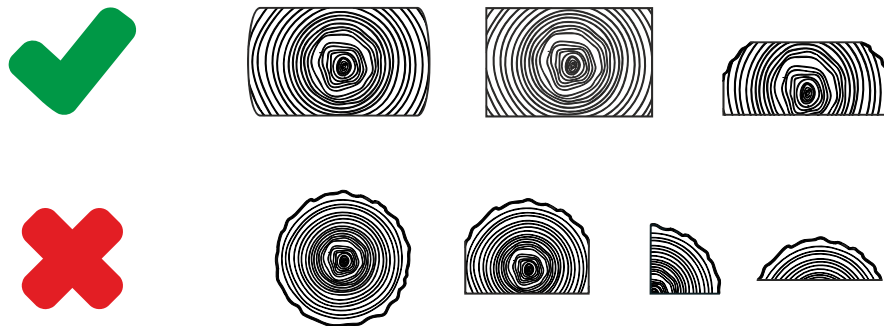

**FIG. 5-1**

See Table 5-1. Noise Level:.

	Noise Level:
<b>MR200E80</b>	$L_{pA} = 83,5 \text{ dB (A)}$ ; $L_{WA} = 106,9 \text{ dB (A)}$

**TABLE 5-1**

See Table 5-4 1 23

1. The noise level measurement was taken in accordance with PN-EN ISO 3746 Standard Value for associated uncertainty  $K=4\text{dB}$ .
2. The measured values refer to emission levels, not necessarily to noise levels in the workplace. Although there is a relation between emission levels and exposure levels, it is not possible to determine with certainty if preventives are needed or are not needed. The factors affecting a current level of noise exposure during work are inter alia room characteristics and characteristics of other noise sources, e.g. number of machines and machining operations nearby. Also, the permissible exposure level value may vary depending on country. This information enables the machine's user to better identify hazards and a risk.
3. The total value of hand-arm vibration the operator may be exposed to does not exceed  $2.5 \text{ m/s}^2$ . The highest root mean square value of weighted acceleration to which the whole operator's body is subjected does not exceed  $0.5 \text{ m/s}^2$ .

### 5.3 Sawdust Extractor Specifications

See **Table 5-5** See the table below for specifications of a sawdust extractor that can be used with the EG800 Multi Saw.<sup>1</sup>

<b>Airflow</b>	3600 m <sup>3</sup> /h
<b>Inlet diameter</b>	2x 150 mm
<b>Motor Power</b>	2x 1,5 kW
<b>Number of sacks</b>	2 pcs
<b>Sack capacity</b>	0.25 m <sup>3</sup>
<b>Pressure drop</b>	1,5 kPa (0.22 psi) <sup>1</sup>
<b>Recommended conveying air velocity in the duct</b>	20 m/s

<sup>1</sup> The pressure drop between the inlet of the capture device and the connection to the CADES should not exceed 1.5 kPa (for the nominal air flow rate). If the pressure drop exceeds 1.5 kPa the machine might not be compatible with conventional CADES.

**TABLE 5-5**



**IMPORTANT!** The sawdust extractor hoses must be grounded or made with materials not accumulating electrostatic charge.



**CAUTION!** Always turn on the dust extractor before starting the machine.

1. External chip and dust extraction equipment with fixed installations are dealt with in EN12779:2016-04.

## 5.4 Noise Level

See Table 5-1. The average level of noise generated by the MR200 sawmill is given in the table below<sup>12</sup>.

Sawmill	Noise Level:
MR2007	$L_{pA} = 84 \text{ dB (A)}$ ; $L_{WA} = 100 \text{ dB (A)}$
LX50G14	$L_{pA} = 96 \text{ dB (A)}$ ; $L_{WA} = 112 \text{ dB (A)}$

TABLE 5-1

1. The noise level measurement was taken in accordance with PN-EN ISO 3746 Standard The noise exposure level given above concerns an 8-hour work day. Value for associated uncertainty  $K=4\text{dB}$ .
2. The measured values refer to emission levels, not necessarily to noise levels in the workplace. Although there is a relation between emission and exposure levels, it is not possible to determine with certainty if preventives are needed or are not needed. The factors affecting a current level of noise exposure during work are inter alia room characteristics and characteristics of other noise sources, e.g. number of machines and machining operations nearby. Also the permissible exposure level can vary from country to country. This information, however, will enable the user of the machine to make a better evaluation of the hazard and risk.

## EC declaration of conformity according to EC Machinery Directive 2006/42/EC, Annex II, 1.A

**Manufacturer:** Wood-Mizer Industries sp. z o.o.  
Nagórna 114, 62-600 Koło; Poland  
Tel. +48 63 26 26 000

This declaration of conformity is issued under the sole responsibility of the manufacturer.

Following machine in our delivered version complies with the appropriate essential safety and health requirements of the EC Machinery Directive 2006/42/EC based on its design and type, as brought into circulation by us. In case of alteration of the machine, not agreed by us, this declaration is no longer valid.

### We, the undersigned herewith declare, that:

Designation of the machine: **MR200 DOUBLE ARBOR MULTIRIP**

TYPE: MR200

No. of manufacturer: .....

### Is in conformity with the following EC directives:

EC Machinery Directive 2006/42/EC  
EC Electromagnetic Compatibility Directive  
2014/30/EU

### And is in conformity with the following Harmonized Standards:

PN-EN ISO 19085-13:2020-10;  
PN-EN ISO 13849-1:2016-02  
PN-EN 60204-1:2018-12

Notified Body according to annex IV : Sieć Badawcza Łukasiewicz  
Krakowski Instytut Technologiczny  
Zakopiańska 73, 30-418 Kraków

Notification No: 1455

EC type-examination certificate no.: 047/CE/1455/2020

Responsible for Technical Documentation: Piotr Adamiec / Engineering Manager  
Wood-Mizer Industries Sp. z o.o.  
62-600 Koło, Nagórna 114, Poland  
Tel. +48 63 26 26 000

Place/Date/Authorized Signature: Koło, 17.12.2020



Title: Engineering Manager