

## user manual

Instrukcja obsługi | Руководство пользователя  
Manuel de l'Utilisateur | Betriebsanweisung  
Bruksanvisning | Manual del Usuario  
Betjeningsvejledning | Gebruikershandleiding  
Käyttöohjeet | Manual de utilizare | Bruksanvisning  
Manuale d'uso | Příručka uživatele | Navodila  
za uporabo

Retain for future use  
Zachować do przyszłego użytku  
Сохраните для последующего  
использования  
A conserver pour une utilisation future  
Für zukünftige Benutzung aufbewahren  
Behold for senere bruk  
Säilytä nämä käyttöohjeet tulevaa tarvetta marten  
Opbevar manualen til fremtidig brug  
Bewaren voor gebruik in de toekomst  
Conservare il presente manuale a l'uso futuro  
Păstrați acest manual pentru utilizare viitoare  
Conservar para futuras consultas  
Behall för framtida användning  
Uchovejte pro další použití  
Hranite za prihodnjo uporabo

# **Wood-Mizer®**

## **Safety, Setup, Operation and Maintenance**

---

**MP360 E16S**

**rev. A1.03**



**Safety is our #1 concern!** Read and understand all safety information and instructions before operating, setting up or maintaining this machine.

Form #2404

### **Original Instructions**

Please keep for future reference

# Table of Content

# Section-Page

<b>SECTION 1</b>	<b>INTRODUCTION</b>	<b>1-1</b>
1.1	Machine Description .....	1-2
1.2	Chip Extractor .....	1-5
1.3	Planer/Moulder Major Components .....	1-6
1.4	If You Need To Order Parts .....	1-7
1.5	If You Need Service .....	1-7
<b>SECTION 2</b>	<b>SAFETY</b>	<b>2-1</b>
2.1	Safety Symbols .....	2-1
2.2	Safety Instructions .....	2-1
<b>SECTION 3</b>	<b>SETUP &amp; OPERATION</b>	<b>3-1</b>
3.1	Moulder Assembly .....	3-1
3.2	Planer/moulder setup .....	3-3
3.3	MP360 planer/moulder operation .....	3-5
<b>SECTION 4</b>	<b>MAINTENANCE</b>	<b>4-1</b>
4.1	Wear life .....	4-1
4.2	Sawdust Removal .....	4-1
4.3	Miscellaneous Maintenance .....	4-1
4.4	Drive Belts Tension Adjustment .....	4-2
4.5	Long-term storage .....	4-6
4.6	Replacement of Inserts in Helical Cutterhead .....	4-7
4.7	Safety Devices Inspection .....	4-8
<b>SECTION 5</b>	<b>PLANER/MOULDER SPECIFICATIONS</b>	<b>5-1</b>
5.1	Overall dimensions .....	5-1
5.2	Specifications of the planer/moulder .....	5-3
5.3	Dust/Chip Extractor Specifications .....	5-7

## SECTION 1 INTRODUCTION

Congratulations on your purchase of a Wood-Mizer Planer - Moulder!

Wood-Mizer is committed to providing you with the latest technology, best quality, and strongest customer service available on the market today. We continually evaluate our customers' needs to ensure we are meeting current wood-processing demands. Your comments and suggestions are welcome.

This documentation includes information on preparing the planer/moulder for operation and operating, servicing and repairing the machine.

### GENERAL

Check your planer/moulder as soon as you receive it. Report any transport damage to the transport company immediately.

Lift the planer/moulder using a forklift or pallet jack with lifting capacity of minimum 800kg.

When replacing spare parts, use only original parts and note that anything electrical must be assembled by a qualified electrician.

### APPLICATIONS

The planer/moulder can be used for planing/moulding/thicknessing and planing wood, chipboard, board, etc.

The planer/moulder can be used for planing/moulding wood, chipboard, board of dimensions listed in "Specification" section. Hard materials such as chipboard, teak, MDF, etc. require hard carbide tools.

It is not allowed to use this machine for planing/moulding any other material such as metal, ice etc.

The planer/moulder is designed for indoor use, with temporary outdoor use during good weather. It not allowed to use or store this machine outdoor when it is raining or snowing.

The planer/moulder should be operated only by an adult who has read and understood the entire operator's manual.

### REQUIREMENTS

Planer/moulder can be used in rooms with temperature range from -15°C to +40 C. Ventilation must be mechanical and in accordance with standards.

The planer/moulder must be connected to a dust/chip extractor. Extractor must be turned on when the machine is working. [See Section 5.3](#) for the dust extractor specification.

## SAFETY DISTANCE



**WARNING!** Other than the operator, no one should be within 3 meters of the planer/moulder's sides or 8 meters from the in and out-feed sides during operation. Mark risk area on the floor.

**TIPS:** An extended infeed table is practical and prevents anyone coming into the risk area.

## 1.1 Machine Description

The Wood-Mizer planer/moulder is designed for straight and profiled planing of wooden elements used for the production of wooden houses and other construction elements used in building industry and garden programs. All other uses of the planer are forbidden.

The MP360 is a planer/moulder that can work four sides of a workpiece in one action. The planer/moulder is contained in a stable and strong chassis. The table is made of planed cast iron.

The workpiece is fed, lying on the planer table, through the planer by feed rollers. The feed rollers are driven by a chain transmission with separate motor. The workpiece feed direction is controlled by adjustable fences and side press rollers.

All cutters are driven by separate motor, using a belt transmission.

Cutters working area is protected by cover with a safety switch.

Another safety switch sits behind the top edge of the cover plate on the infeed side.

A 100 mm (4") dia. hose is connected to the bottom and side cutters and a 125 mm (5") dia. hose is connected to the top cutter.

### TABLE SURFACE

Table is made with a highest quality cast. The table surface is specially processed for the highest precision and the best anti-friction qualities.

When the planer/moulder is new, it requires a breaking-in period until the table gets a slightly shinier surface to optimize the anti-friction qualities. During this period it is recommended to use a lubricant or wax on the table.

Using the machine correctly, you will obtain a perfectly smooth surface and a high degree of accuracy.

Planer/moulder is built to be durable and easy to operate and maintain.

## MACHINE AND SITE PREPARATION

The machine is delivered on pallet. Due to the weight, it has to be transported with auxiliary lifting equipment and in accordance with general safety rules.

Check your planer/moulder as soon as you receive it. Any transport damage must be reported to the transport company immediately.

Most of the planer/moulder is protected against rust, but it will require extra maintenance in the form of lubrication for all the parts not protected against rust. See the Maintenance section.

- Place the planer on a stable and flat base.
- It is recommended to screw the planer/moulder down to the floor, if it does not have to be moved.
- Ensure that there is enough space for the longest boards you want to plane at the in and outfeed sides, and that there is enough space for maintenance and timber stocks.
- Connect the dust hoses and fix using the hose clips on the planer and fan.
- Hang the planer/moulder's electrical cable on the ceiling or protect it in another way. Never step on the cable. The planer/moulder should be connected via an earth-fault protection switch.
- CAUTION! The illumination at the operator's position should be at least 300lx. The light source can not cause stroboscopic effect. Ensure that there is no risk of glare.

## SPACE REQUIREMENTS

The planer/moulder needs a space of at least 3 m wide.

The length required depends on the length of the workpieces you want to plane. The minimum length is 8 m.

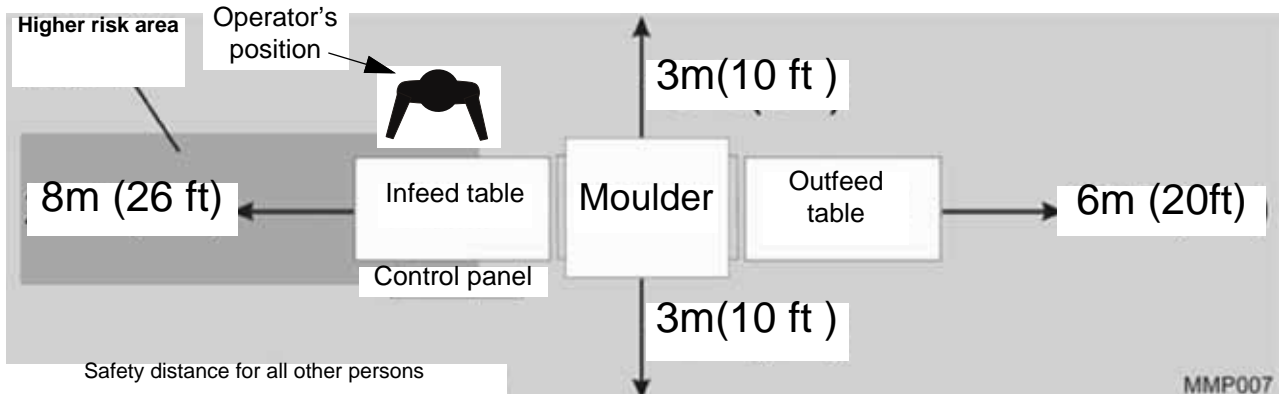

---

## **ANCHORING**

It is recommended that the MP360 planer/moulder be anchored to the floor using 12 mm screws.

### **LIST OF THE TOOLS REQUIRED TO WORK WITH THE PLANER/ MOULDER:**

- Hex key 4 mm (supplied)
- Hex key 5 mm
- Hex key 6 mm
- Open ended wrench 10 mm (supplied)
- Wrench 10 mm
- Ring wrench 13 mm
- Open ended wrench 30 mm (supplied)
- Adjustable wrench 8" or 10"
- Sliding caliper
- Measuring tape or ruler
- Paraffin oil for the table
- Whetstone

### **FOLLOWING SPACER RINGS ARE SUPPLIED:**

- 3 x 40 mm height (per cutter)
- 2 x 20 mm height (per cutter)
- 2 x 10 mm height (per cutter)
- 1 x 5 mm height (per cutter)
- 2 x 2 mm height (per cutter)
- 1 x 1 mm height (per cutter)
- 1 x 0.5 mm height (per cutter)
- 1 x 0.3 mm height (per cutter)
- 1 x 0.2 mm height (per cutter)

- 1 x 0.1 mm height (per cutter)

These spacer rings are necessary to set the required height.

## 1.2 Chip Extractor

MP360 planer/moulder must be connected to chip extractor with a capacity of at least 5 000m<sup>3</sup>/h. Remember that chip container has to be equipped with an air vent (e.g. a fine net or filter if dust are collected indoors). During work in heated rooms, it is necessary to remember that the fan will quickly cool the space if the filtered air will not be supplied back into the building.

Contact the local authorities for advice in designing a chip collection system to conform with national rules.

It is necessary to set the fan so that it will be easy to reach the switch.



**IMPORTANT!** Remove the chips from the planer/moulder when the work is finished.

### CHIP EXTRACTOR TECHNICAL REQUIREMENTS<sup>1</sup>

- The chip extractor must be approved according to the CE-standard.
- The airflow "without external connection" must be approx. 5000 m<sup>3</sup>/hour. (The manufacturer's standard indication of airflow.)
- The chip extractor hose diameters for the planer/moulder = 100 mm (4") x 3 and 125 mm (5") x 1.
- Pressure drop should not exceed 1,5 kPa.



**IMPORTANT!** The dust extractor hoses must be grounded or made with materials not accumulating electrostatic charge.



**CAUTION!** Always turn on the chip extractor before starting the machine

---

1. EN 12779:2016-04 standard contains requirements for chip and dust extraction systems equipment with fixed installations.



### 1.3 Planer/Moulder Major Components

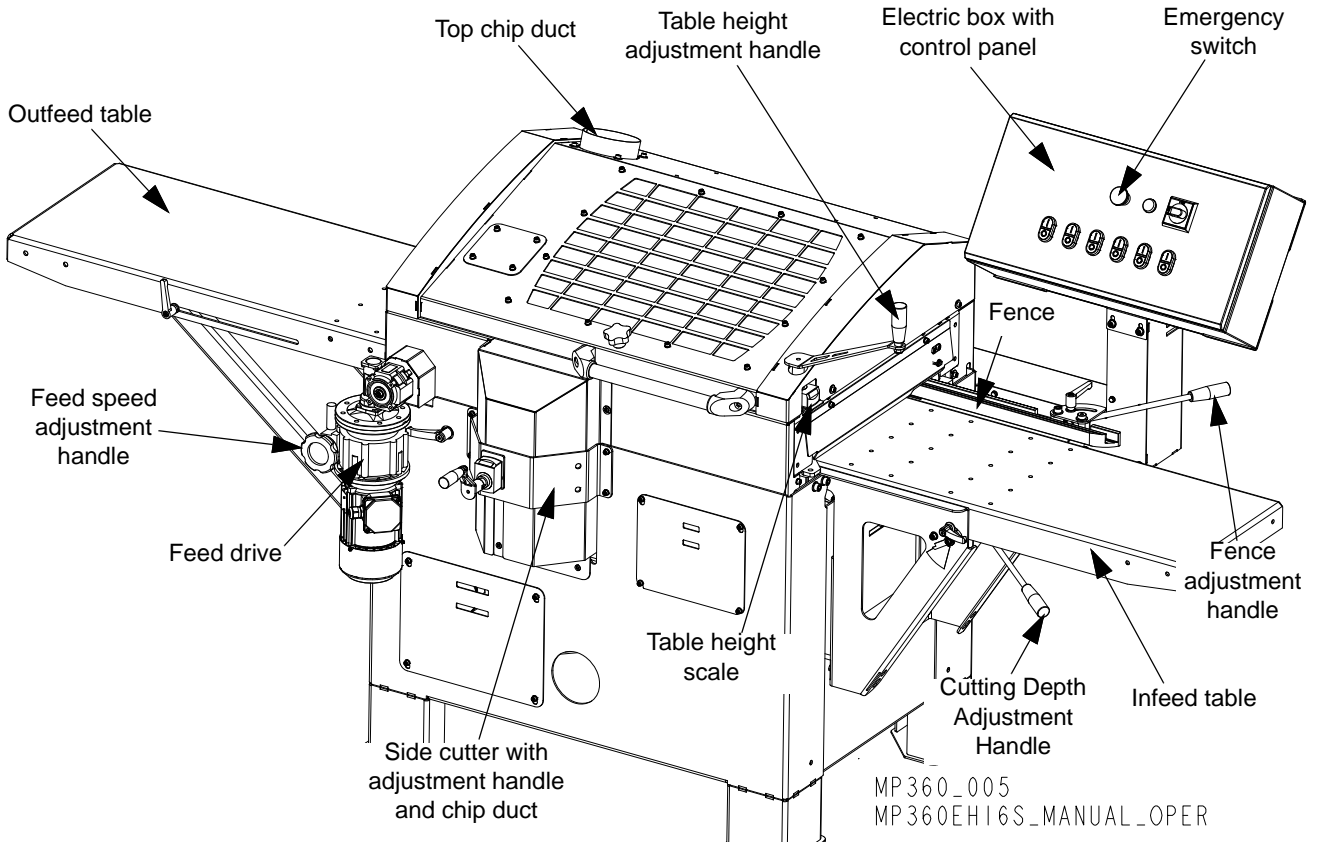

**FIG. 1-1 MP360**

## 1.4 If You Need To Order Parts

From Europe call your local distributor or our European Headquarters and Manufacturing Facility in Kolo, Nagórna 114 St, Poland at +48-63-2626000. From the continental U.S., call our toll-free Parts hotline at **1-800-525-8100**. Please have the machine identification number and your customer number ready when you call. Wood-Mizer will accept these methods of payment:

- Visa, Mastercard, or Discover
- COD
- Prepayment
- Net 15 (with approved credit)

Be aware that shipping and handling charges may apply. Handling charges are based on size and quantity of order.

## 1.5 If You Need Service

From Europe call your local distributor or our European Headquarters and Manufacturing Facility in Kolo, Nagórna 114 St, Poland at +48-63-2626000. From the continental U.S., call us toll-free at **1-800-525-8100**. Ask to speak with a Customer Service Representative. Please have your machine identification number and your customer number ready when you call. The Service Representative can help you with questions about the operation and maintenance of your sawmill. He also can schedule you for a service call.

### Office Hours:

Country	Monday - Friday	Saturday	Sunday
Poland	7 a.m.- 4 p.m.	Closed	Closed
US	8 a.m.- 5 p.m.	8 a.m.- 5 p.m	Closed

## SECTION 2 SAFETY

### 2.1 Safety Symbols

The following symbols and signal words call your attention to instructions concerning your personal safety. Be sure to observe and follow these instructions.

 **DANGER!** indicates an imminently hazardous situation which, if not avoided, will result in death or serious injury.

 **WARNING** suggests a potentially hazardous situation which, if not avoided, could result in death or serious injury.

 **CAUTION!** refers to potentially hazardous situations which, if not avoided, may result in minor or moderate injury or damage to equipment.

 **IMPORTANT!** indicates vital information.

**NOTE:** gives helpful information.

 Warning stripes are placed on areas where a single decal would be insufficient. To avoid serious injury, keep out of the path of any equipment marked with warning stripes.

### 2.2 Safety Instructions

**NOTE:** ONLY safety instructions regarding personal injury are listed in this section. Caution statements regarding planer/moulder damage appear where applicable throughout the manual.

- Observe Safety Instructions

 **IMPORTANT!** Read the entire Operator's Manual before operating the planer/moulder. Take notice of all safety warnings throughout this manual and those posted on the equipment. Keep this manual with this equipment at all times, regardless of ownership.

Read all additional manufacturer's manuals and observe any applicable safety instructions including dangers, warnings, and cautions!

**IMPORTANT!** Only adult persons who have read and understood the entire operator's manual should operate the planer/moulder. The sawmill is not intended for use by or around children. Never operate the planer/moulder under the influence alcohol or any other drugs.

**IMPORTANT!** The operator of the planer/moulder should get adequate training in the operation and adjustment of the machine.

**IMPORTANT!** It is always the owner's responsibility to comply with all applicable federal, state and local laws, rules and regulations regarding the ownership and operation of your Wood-Mizer planer/moulder. All Wood-Mizer planer/moulder owners are encouraged to become thoroughly familiar with these applicable laws and comply with them fully while using the planer/moulder.



- Wear Safety Clothing



**WARNING!** Secure all loose clothing and jewelry before operating this machine. Failure to do so may result in serious injury or death.

**WARNING!** Wear safety goggles and gloves when operating machinery. Failure to do so may result in serious injury.

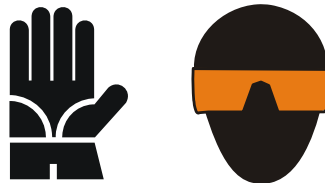

**WARNING!** Always wear ear, respiration and foot protection when operating planer/moulder.



- Keep the Machine And Area Around Clean



**DANGER!** Maintain a clean and clear path for all necessary movement around the planer/moulder and lumber stacking areas. Failure to do so will result in serious injury.

- Dispose of Sawing By-Products Properly



**IMPORTANT!** Always properly dispose of all sawing by-products, including sawdust and other debris.

- Check planer/moulder before operation.



**DANGER!** Make sure all guards and covers are in place and secured before operating planer/moulder. Check that knobs, screws, nuts, fences, sleeves, planing cutters, planing knives, etc. are properly tightened. Also check that the cutter can rotate freely and that there are no tools in or on the planer/moulder before it is started. Failure to do so may result in serious injury.



**WARNING!** Always shut off the motor to stop the cutter whenever the planer/moulder is not in use. Failure to do so may result in serious injury.

**WARNING!** Do not for any reason adjust the engine drive belts with the engine running. Failure to do so will result in serious injury.

- Keep all people away



**DANGER!** Other than the operator, no one should be within 3 meters of the planer/moulder's sides during operation. Failure to do so will result in serious injury.

- Keep Hands Away

**DANGER!** Moving parts can cut or crush fingers or hand. Keep hands clear. Make sure all guards and covers are in place and secured before operating the planer/moulder. Failure to do so may result in serious injury.

**DANGER!** Always be aware of and take proper protective measures against rotating shafts, pulleys, fans, etc. Always stay a safe distance from rotating members and make sure that loose clothing or long hair does not engage rotating members resulting in possible injury.

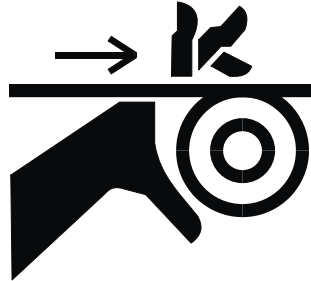

**WARNING!** Beware of rotating parts. Shut down the sawmill and allow all moving parts to come to a complete stop before removing any guards and covers. Do NOT operate planer/moulder with any guards or covers removed.

**DANGER!** Before changing the knives or performing any service to planer/moulder, disconnect the power cord from the electric box.

**IMPORTANT!** Knife and feed assembly covers are equipped with limit switches. After opening the cover, engine will turn off and all moving parts will stop. Limit switches should be always in proper working condition.

### **Planer/moulder operation**



**CAUTION!** The workplace always should be good illuminated. The illumination at the operator's position should be at least 300lx. Never use the planer/moulder under the influence of strong medication, alcohol or any other strong drugs.



**WARNING!** Make sure the knives are properly fastened before starting the motor.



**WARNING!** Never place tools or hands into the in or outfeed areas when the planer/moulder is running.



**IMPORTANT!** When starting the machine for the first time, check that cutter rotation direction is as indicated by the arrow located on the side cover. If the rotation direction is incorrect, invert the phases in the phase inverter in the power socket (electric box). Setting the phases in the phase inverter correctly will ensure correct rotation directions of cutter.



**DANGER!** Always measure the workpiece and set suitable thickness and width before planing. There is a risk of accident if you feed in a workpiece that is not high enough for the feed rollers to get hold of it.

When planing smaller material, it should be stiffened/extended, e.g. with a longer piece of wood.

Never stand in front of the material being fed or received, because it may suddenly kickback uncontrollably towards the operator. This applies to both the in and outfeed sides, although the risk is higher on the infeed side.



**DANGER!** Planing/moulding is possible only in direction shown below. Arrow indicates planing direction. Never try planing/moulding in the opposite direction.

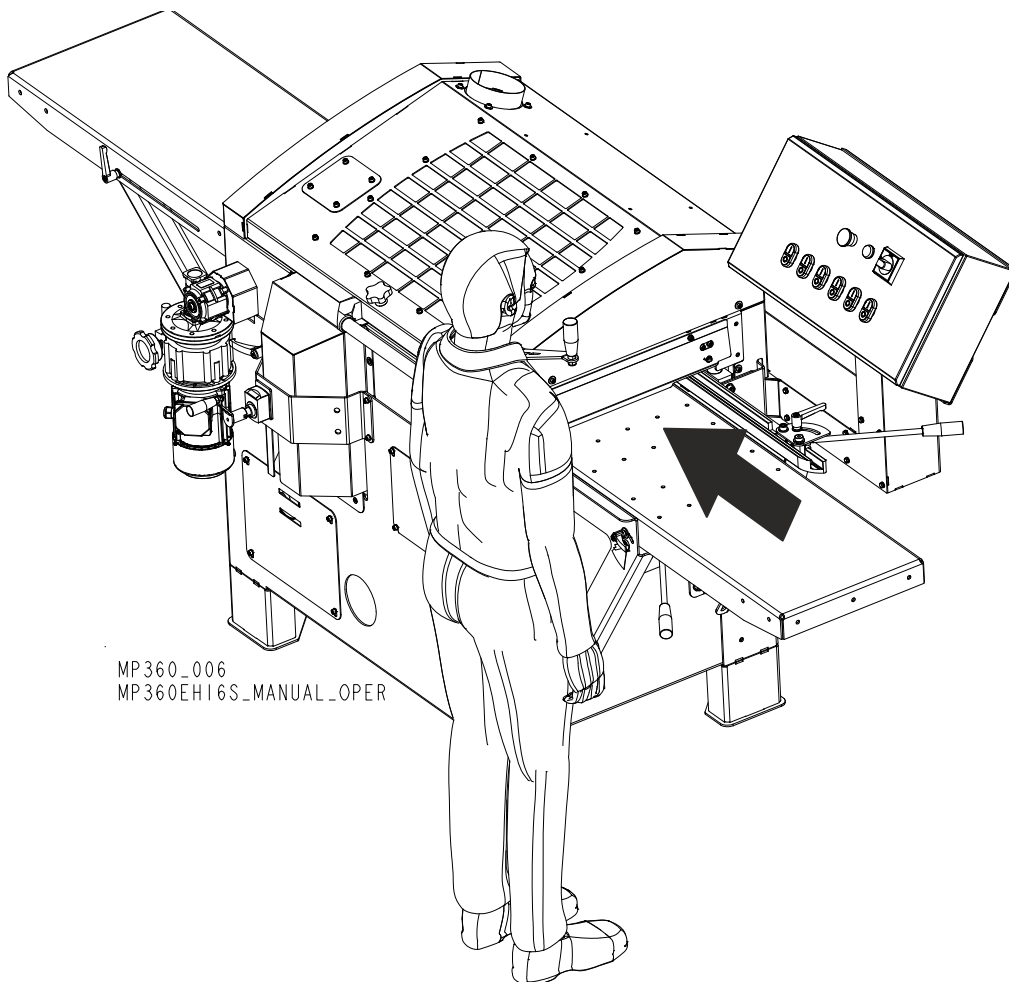

**FIG. 2-1 MP360**

- Use proper maintenance procedures



**DANGER!** Make sure all electrical installation, service and/or maintenance work is performed by a qualified electrician and is in accordance with applicable electrical codes.

**DANGER!** Hazardous voltage inside the electric boxes and at the motor can cause shock, burns, or death. Disconnect and lock out power supply before servicing! Keep all electrical component covers

closed and securely fastened during mill operation.



**WARNING!** Consider all electrical circuits energized and dangerous.

**WARNING!** Never assume or take the word of another person that the power is off; check it out and lock it out.

**WARNING!** Do not wear rings, watches, or other jewelry while working around an open electrical circuit.



**IMPORTANT!** Planer/moulder is equipped with emergency switch. It is used to immediately stop the machine in case of emergency. Emergency switch should be always in good condition.

**IMPORTANT!** Planer/moulder should not be modified by owner. Use only original spare parts.

- Keep safety labels in good condition.



**IMPORTANT!** Always be sure that all safety decals are clean and readable. Replace all damaged safety decals to prevent personal injury or damage to the equipment. Contact your local distributor or Wood-Mizer Customer Service to order more decals.

**IMPORTANT!** If replacing a component which has a safety decal affixed to it, make sure the new component also has the safety decal affixed in the same place.

- Fire protection

**CAUTION!** The work-stand of the planer/moulder should be equipped with a 4 kg or bigger dry powder extinguisher.



**Safety Labels Description**

See table below for safety labels description.

**TABELA 2-0**









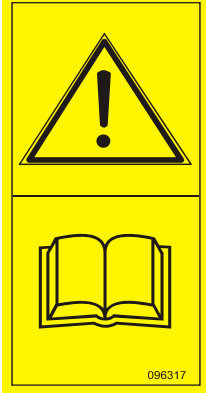

Label View	Label Number	Description
	096317	CAUTION! Carefully read operator's manual before handling the machine. Observe instructions and safety rules when operating.
	099220	Close guards prior to operating the machine
	099221	CAUTION! Keep safe distance when the machine is operating.

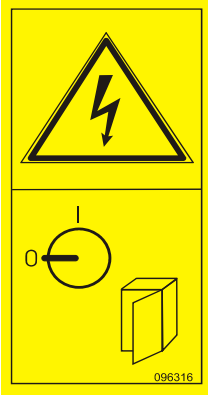
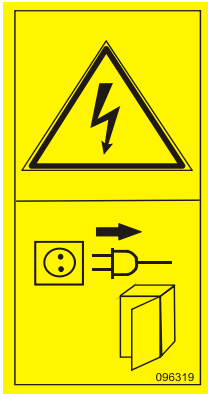
TABELA 2-0

	<p>096316</p>	<p>Electric box opening is possible with the switch in "0" position only.</p>
	<p>096319</p>	<p>Always disconnect the power cord before opening the electric box.</p>
	<p>524993</p>	<p>CAUTION! Hand injury hazard</p>
	<p>S12004G</p>	<p>Always wear safety goggles when operating the planer/moulder!</p>

**TABELA 2-0**

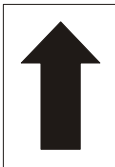
	S12005G	Always wear protective ear muffs when operating the planer/moulder!
	501465	Always wear safety boots when operating the planer/moulder!
	512107-1	Always wear safety gloves when operating the planer/moulder!
	S20098	Motor rotate direction
	087649 502481	Warning stripes
	P85070	CE safety certification

## SECTION 3 SETUP & OPERATION

### 3.1 Moulder Assembly

Some of the machine components need to be assembled by the user before first usage.

1. **Infeed table.** Completely screw in all the adjusting screws (B). Install the mounting screws (A) and tighten by hand. Install adjusting screws (C7, C8) and using them adjust the table, so it is level. Using adjusting screws (B) set the height of the infeed table so it is at the same height as the moulder cast iron table (double check this with a long, straight tube or flat board) and the tables touches each other. Tighten the mounting screws (A). Tighten bottom mounting screws (D7, D8) and re-check the table level and height.

See Figure 3-1.

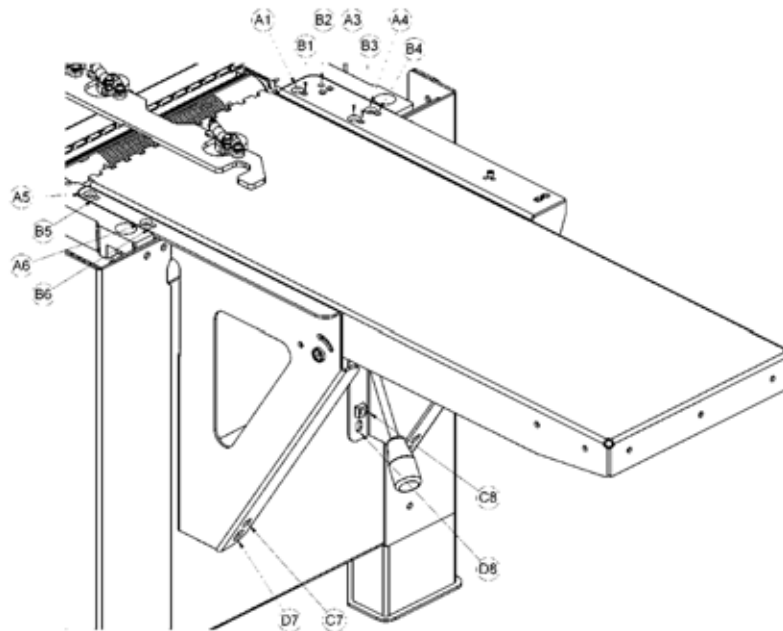

FIG. 3-1

2. **Guide fence.** Mount the guide fence according to the figure below.

See Figure 3-2.

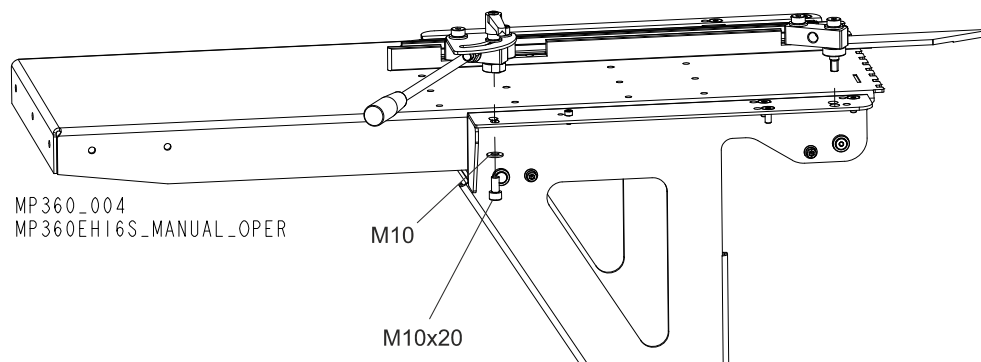
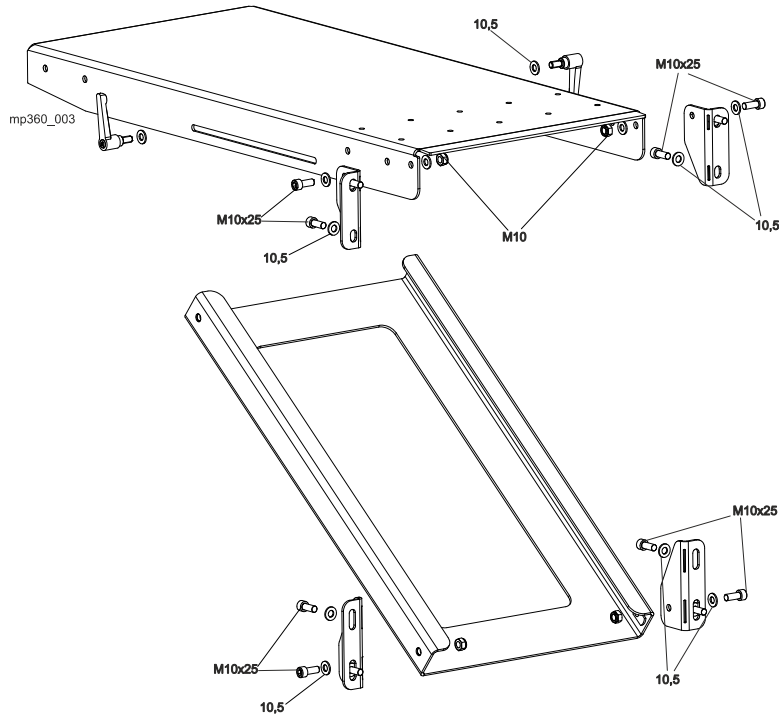

FIG. 3-2

3. **Outfeed table.** Mount the outfeed table according to the figure below.  
 See Figure 3-3.



**FIG. 3-3**

4. **Operator's panel.** Dismount the back cover (A). Mount the operator's panel (B) using four M8x25 socket head bolts. Place all the cables inside the panel arm. Re-mount the back cover (A).

See Figure 3-4.

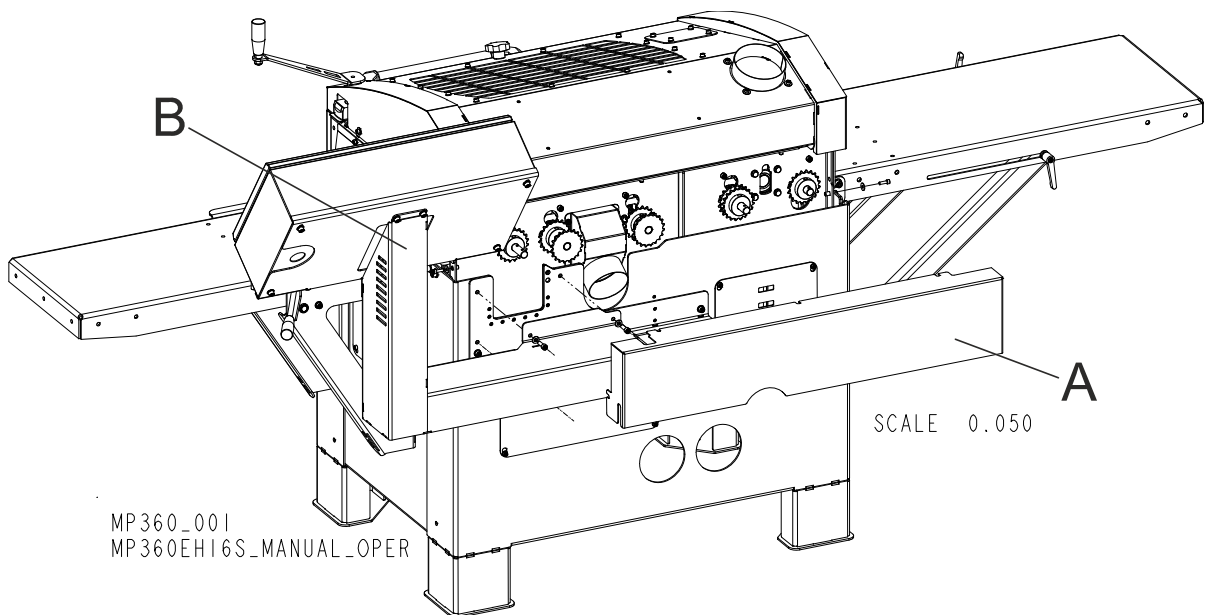

**FIG. 3-4**

### 3.2 Planer/moulder setup



**IMPORTANT!** Before starting to use the planer/moulder you have to meet the following conditions:

- Set up the planer/moulder on firm, level ground and level the planer/moulder. Secure the planer/moulder to the ground to prevent moving during operation. A cement pad with 12 mm diameter anchor bolts is recommended.
- Indoors the planer/moulder can be operated with the sawdust collection system only.
- The planer/moulder can not be operated when it is raining/snowing and in case of rain or snow the machine must be stored under roof or indoors.
- The planer/moulder can be operated in temperature range from  $-15^{\circ}\text{C}$  to  $40^{\circ}\text{C}$  only.
- The illumination at the operator's position should be at least  $300\text{lx}^1$ .
- The planer/moulder's operator position and E-Stop safety buttons location are shown below.

See Figure 3-5.

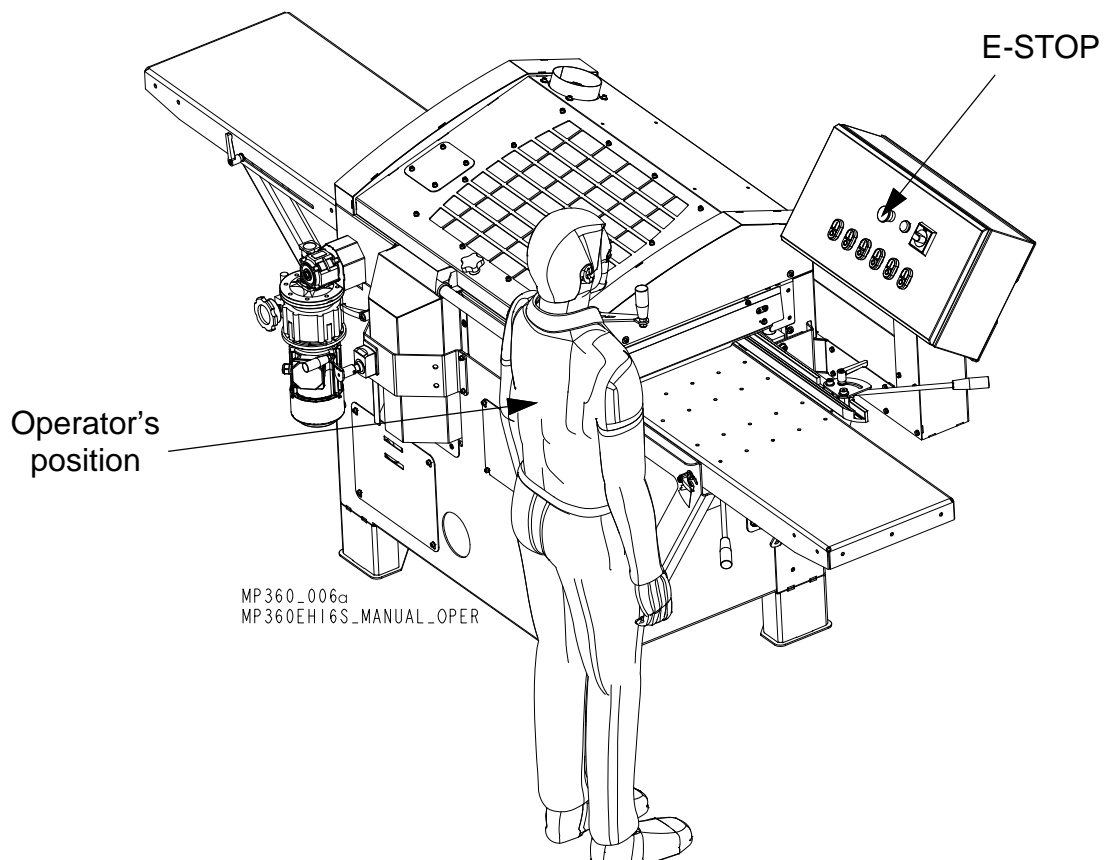

FIG. 3-5 MP360

1. Light source must not cause stroboscopic effect.

See **table 3-1**. Have a qualified electrician install the power supply (according to EN 60204 Standard). The power supply must meet the specifications given below.

Model	3-Phase Volts	Fused Disconnect Switch	Suggested Wire Size
MP360	400 VAC	35 A	6 mm <sup>2</sup> up to 15 m long

**TABLE 3-1**



**IMPORTANT!** It is recommended that a 30mA GFI (Ground Fault Interrupter) be used.



**IMPORTANT!** When starting the machine for the first time, check that main motor rotation direction is as indicated by the arrow located on the motor body (fan guard). If the rotation direction is incorrect invert the phases in the phase inverter in the power socket box). Setting the phases in the phase inverter correctly will ensure correct rotation directions of all sawmill motors.



**WARNING!** In case of a drive belt break, wait until all rotating parts are completely stop. Failure to do so may result in serious injury or death.



**DANGER!** Use the inspection window to check cutter rotation direction. To do it, look at the motor fan when planer/moulder is turning on or off. Do not check the cutter rotation direction by touching the cutter with any tool. Failure to do so will result in serious injury of death.

**BEFORE STARTING:**

- Check that no tools have been left in the planer.
- Check that the cutters can rotate freely before the safety doors are closed.
- Review the safety instructions!
- Be sure the emergency switch button is released;
- Be sure the upper cover is closed and the limit switch is activated. Be sure all machine's parts are tightened, especially working element covers.
- Be sure that no one than operator is in the high risk area.
- Turn on the chip extractor.



**DANGER!** Connect the planer/moulder electrical installation. Check the rotational direction. Looking from the transmission, the upper cutter must rotate in the opposite direction to the material feed direction (to the left).

### 3.3 MP360 planer/moulder operation

#### 3.3.1 Control panel

See **Figure 3-6**. MP360 planer/moulder controls are shown below.

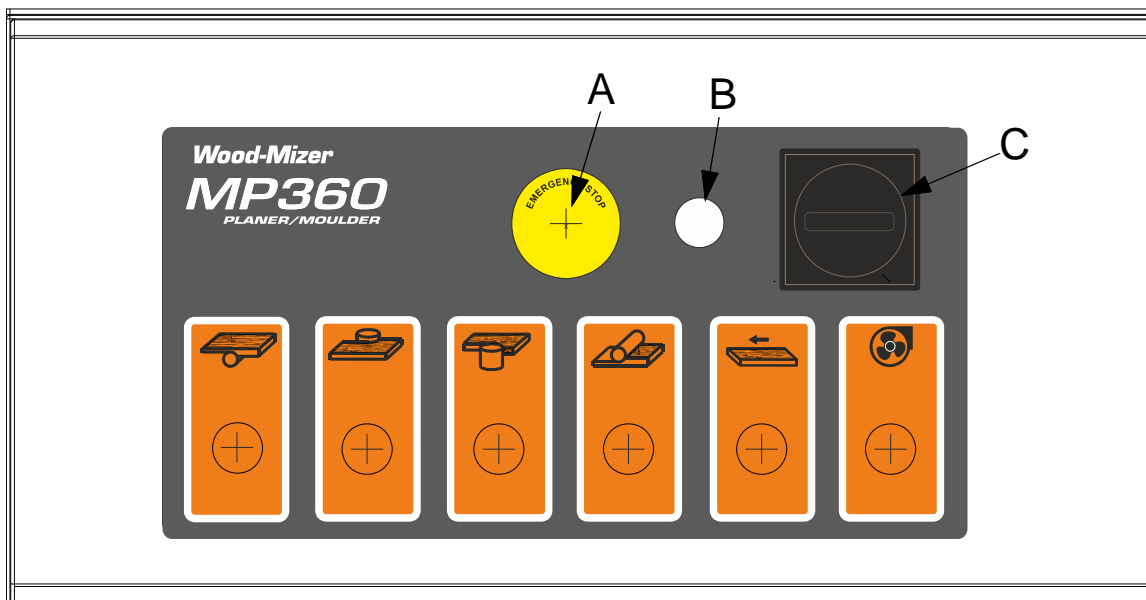

**FIG. 3-6** MP360

- **Emergency Stop Button (A).** Push the emergency stop button to stop the machine. Turn the emergency stop clockwise to release the stop. The machine will not restart until the emergency stop is released.
- **Power ON Control Light (B).** Indicates the power supply.
- **Main disconnection switch (C).** Disconnects the power supply from all electrical circuits of the machine.

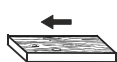

- **Material Feed.** Press white “I” button to start material feed. Press black “0” button to stop the feed.



- **Upper cutter.** Press white “I” button to start the upper cutter. Press black “0” button to stop the upper cutter.

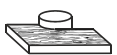

- **Right cutter.** Press white “I” button to start the right cutter. Press black “0” button to stop the right cutter.



- **Left cutter.** Press white “I” button to start the left cutter. Press black “0” button to stop the left cutter.





- **Lower cutter.** Press white “I” button to start the lower cutter. Press black “0” button to stop the lower cutter.



- **Dust/chip extraction system.** To start the fan of this system, press the white „I” button. To stop the fan, press the black „0” button.



### 3.3.2 Lower cutter

-  **DANGER!** Before you open the safety covers of the planer, ensure that the power is switched off and that the cutters are not rotating.
-  **WARNING!** Use protective gloves, particularly when you need to loosen screws that are tightly fastened, or when you are tightening screws (see safety instructions).
-  **WARNING!** Always wear gloves and eye protection when mounting/dismounting the knives. The knives are very sharp. You can hurt yourself even when you touch the knife lightly.

The lower cutter is fixed to the planer table from the infeed side. Two planning knives are mounted in two of four cutter's slots upon delivery (planer knife 410 mm (16") HSS). Another two planning knives, can be mounted in the two empty slots.

#### SETTING THE CUT OF THE LOWER CUTTER

Planning thickness of the lower cutter is set by adjusting the position of the infeed table using a lever "A" (see below). Position of the infeed table is locked using locking handle "B". Actual planning thickness can be read from the scale "C". Typical planning thickness of the lower cutter is 2 mm (8/100").

See Figure 3-7.

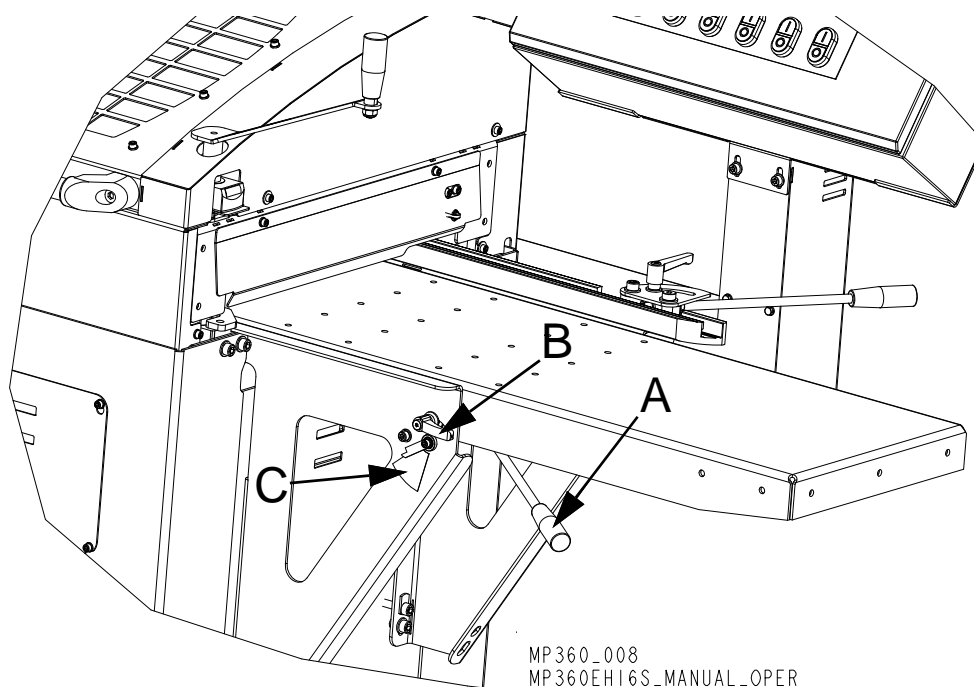

MP360\_008  
MP360EH16S-MANUAL\_OPER

FIG. 3-7

**DISASSEMBLING, ASSEMBLING AND GRINDING PLANING KNIVES**

See Figure 3-8.

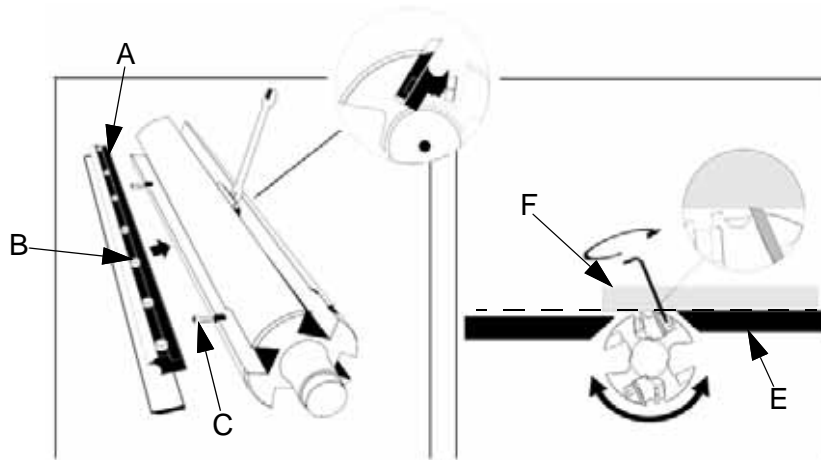

**FIG. 3-8**

The planing knife can be disassembled by loosening the chip breaker's (A) lock screws (B) and then removing the planing knife with adjuster screws (C).

**GRINDING THE PLANING KNIVES**

Always grind the knives in pairs, so they are the same height (min. 15 mm). Otherwise vibrations could occur in the cutter. The grinding angle must be 38 degrees.

**ADJUSTING THE LOWER CUTTER PLANING KNIVES**

- Loosen the chip breaker's lock screws (B) using a 10 mm (4/10") wrench (supplied).
- The knife can be raised or lowered using the two adjustable screws (C). Use a 4 mm socket key (supplied). The bottom cutter's planing knives must be adjusted so that they are on the same level as the cast iron planer table (E). Place a straight, flat board or cant (F) on the cast iron table over the lower cutter. Adjust the knife, so the knife in his highest position slightly touches the board. Repeat with all other remaining knives.
- Tighten firmly the chip breaker's lock screws (B) on each knife.

After adjusting or replacing planing knives:

- Check that no tools have been left in the planer.
- Check that all screws have been tightened properly.
- Check that the cutters can rotate freely.
- Review the safety instructions!

### 3.3.3 Top cutter

 **DANGER!** Before you open the safety doors of the planer, ensure that the power is switched off and that the cutters are not rotating.

 **WARNING!** Use protective gloves, particularly when you need to loosen screws that are tightly fastened, or when you are tightening screws (see safety instructions).

 **WARNING!** Always wear gloves and eye protection when mounting/dismounting the knives. The knives are very sharp. You can hurt yourself even when you touch any knife lightly.

#### SETTING THE CUT OF THE TOP CUTTER

The planing thickness of the upper cutter is set using the crank (A). Before setting the planing thickness it is necessary to loosen the locking handle (B). The set thickness can be read on the indicator (C). The indicator can be calibrated:

- Plane some wood to obtain the material of desired height.
- Open the cover (D), remove the crank (E) and dismount the indicator cover (F).
- Loosen the lock screw on the ring (G) and turn the ring so that it shows the planing height that has been planed.
- Tighten the lock screw.

See Figure 3-9.

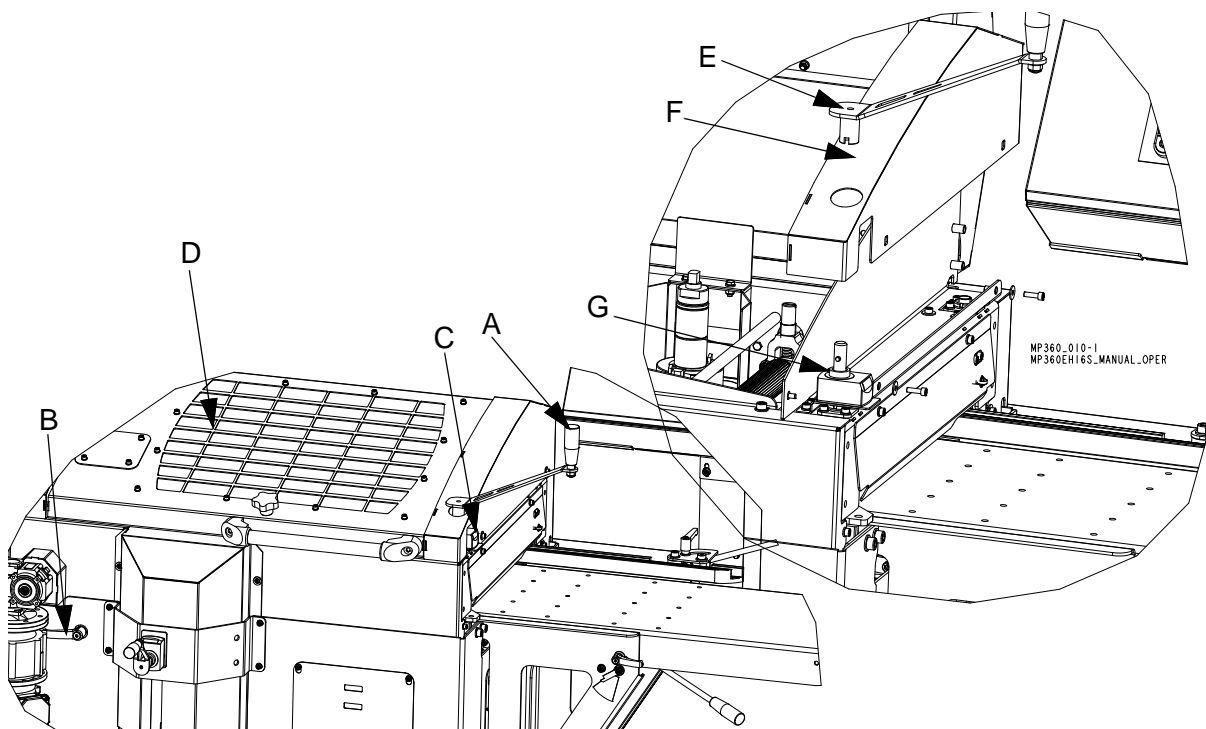

FIG. 3-9

The MP360 Moulder is delivered with two 510 mm (20") HSS knives. Another two planing knives can be mounted in empty slots.

The top cutter is mounted to the planer body through elongated slots which allows to adjust the upper cutter in horizontal direction. However it is recommended to adjust the cutter in its extreme up position.

### GRINDING THE PLANING KNIVES

Always grind the knives in pairs, so they are the same height, min. 15 mm, otherwise vibrations could occur in the cutter. The grinding angle must be 38 degrees.

### ADJUSTING THE PLANING KNIVES

Adjust the planing knives so that they are the same level and protrude 1 mm (.040"). This is done using an aluminum adjustment block, which is delivered with the machine.

Loosen the chip breaker's lock screws (A) slightly, and place the adjustment block (B) over the knife (C). Position the block on the left side of the cutter. Adjust the knife up or down until the knife touches the block. Then position the block on the right side of the cutter and repeat adjusting the knife. Then adjust all remaining knives. After all knives are adjusted properly, tighten firmly the chip breaker lock screws.

(The planing knife protrusion can also be adjusted using a magnetic adjuster for the top cutter. See the instructions enclosed with the magnetic adjuster.)

See Figure 3-10.

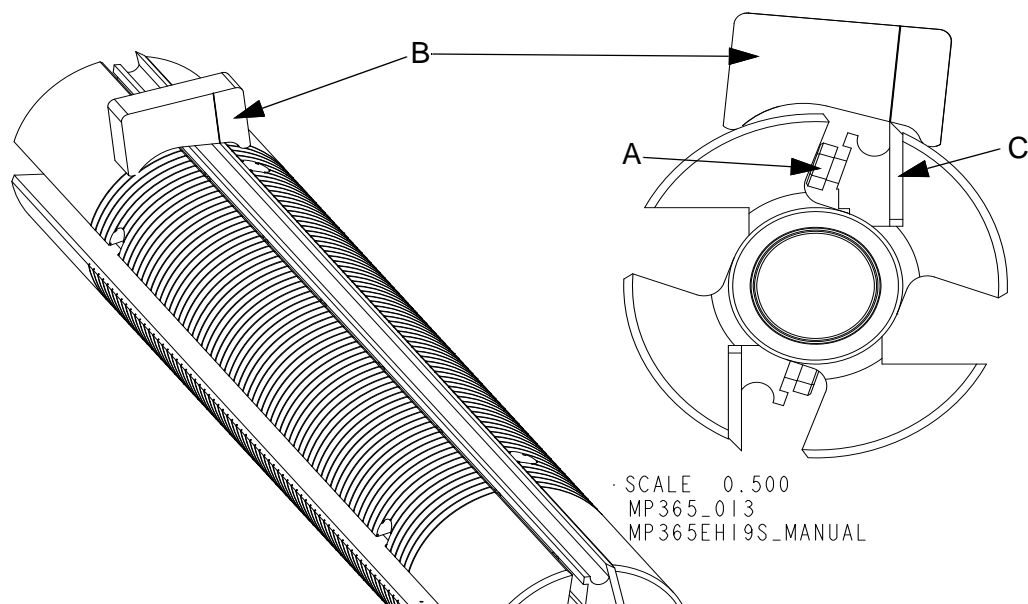

**FIG. 3-10**

After adjusting or replacing planing knives:

- Check that no tools have been left in the planer.
- Check that all screws have been sufficiently tightened.
- Check that the cutters can rotate freely before the safety cover is closed.
- Review the safety instructions!

### 3.3.4 Chain transmission with trapezoidal thread adjustment

The chain used to raise and lower the table, must not be slack, but needs to be tensioned enough that teeth mesh correctly.

The chain tension is adjusted with tensioning pulley. Remove the cover (A), loosen the lock nuts (B) and move the pulley (C) to tension properly the chain. Do not over-tension the chain.

Do not adjust the chain tension, when table is raising or lowering.

See Figure 3-11.

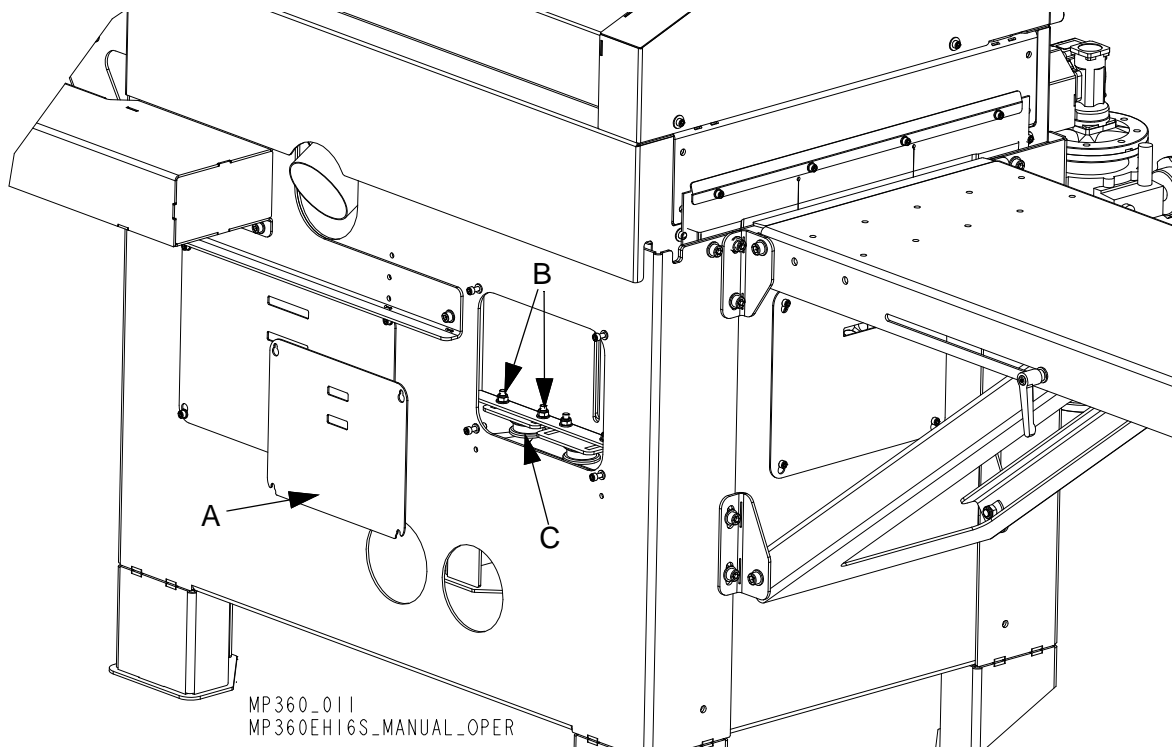

**FIG. 3-11**

### 3.3.5 Side cutter

**WARNING!** Before you open the safety doors on the planer, ensure that the power is switched off and that the cutters are not rotating.

**WARNING!** Use protective gloves, particularly when you need to loosen screws that are tightly fastened, or when you are tightening screws (see safety instructions).

See Figure 3-12.

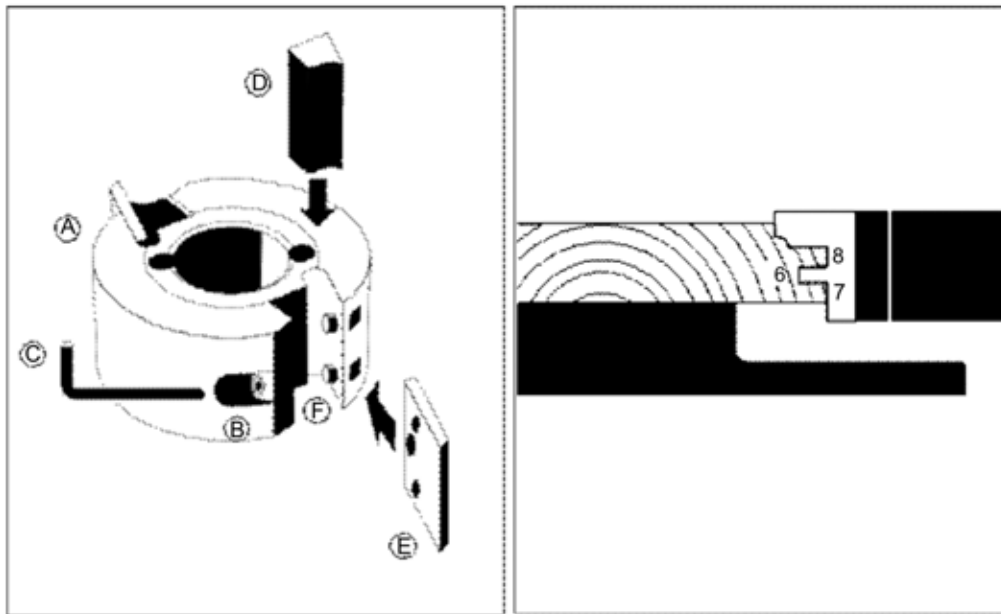

FIG. 3-12

The side cutter is fixed to the planer table with 30 mm diameter spindle, which is a standard dimension. Planer/moulder is equipped with one universal side cutter with planing knives, which can be easily replaced with molding knives. Lock nut and spindle on the movable side cutter have left threads.



**IMPORTANT!** Movable side cutter lock nut has left thread.

After mounting knives perform the following steps:

- Check that no tools have been left in the planer.
- Check that all screws have been sufficiently tightened.
- Check that the cutters can rotate freely before the safety doors are closed.
- Review the safety instructions!

### DISASSEMBLING

**Fixed side cutter:** Loosen the nut on the spindle with a 30 mm wrench (supplied) and a 13 mm wrench or adjustable wrench. Unscrew the nut and remove the cutter (A) and any spacing rings under the cutter.



**IMPORTANT!** Loosen side cutter nuts by turning them in the same direction as cutter rotation direction.

**Movable side cutter:** The nut is loosened in the same way as for fixed side cutter, with the difference that the nut for movable side cutter has left thread and is therefore screwed in the opposite

direction.



**IMPORTANT!** Loosen side cutter nuts by turning them in the same direction as cutter rotation direction. The nut of the movable side cutter has left thread.

## REPLACING KNIVES

Loosen the lock screw (B) with a 4 mm Allen wrench (C) (supplied) and remove the chip breaker (D). Then remove the knife (E) from the dowel pin (F). Next tighten the locking screw firmly.



**IMPORTANT!** Be sure the knives in the cutter are in proper direction. The cutting edge must be pointed to the chip breaker. Check if cutter is properly set on the spindle.



**IMPORTANT!** All planer/moulder cutters should turn in opposite direction to the feed direction.

Check that the corrosion-proof spring plate located in front of the movable cutter will not be bent towards the cutter by the workpiece. Pay particular attention when cutting workpieces of different widths.

Be sure that the cutter can rotate freely and chip barrier plate located behind the cutter is 5 mm from the knife.

## HEIGHT SETTING

The side cutter's height is set by adding or removing the spacers that are delivered in the component package.

Spacers height:

- Spacer 40 mm
- Spacer 20 mm
- Spacer 10 mm
- Spacer 5 mm
- Shims set (0.1 – 2.0 mm)

To remove the planing knife from the side cutter, use 4mm Allen wrench (supplied) to loosen lock screws that are recessed into the cutters.

## THE HEIGHT SETTINGS FOR TONGUE AND GROOVES:

When tongues and grooves need to be moulded, it is important that they are made opposite one another, i.e. at the same height above the planing table. Remove the cutter from the spindle (see information above).

- Decide how the board should look. E.g. 8 mm above the groove, 6 mm thick groove and 7 mm below the groove.
- Assemble the molding knife and tighten the socket head screw that hold the knife properly.
- Place the cutter on the spindle without any spacers.
- Measure the distance between top edge of the bottom knife and planer/moulder table.

If the cutter is 40 mm and the groove (6 mm in this example) is in the middle of the knife, the height of the knife above the groove is 17 mm.

When the cutter is preset, the height of the knife above the table must be 30 mm ( $7 + 6 + 17 = 30$  mm). If, for example, the height of the knife above the table is measured to 15.2 mm, the cutter must be raised 14.8 mm (0.58") ( $15.2 + 14.8 = 30$  mm).

Take the following measures:

- Remove the cutter.
- Combine spacers to the calculated thickness (14.8 mm (0.58") in this example) and thread them onto the spindle.
- Place the cutter on the spindle, screw on the lock nut and tighten properly. Check that the cutter can rotate freely.
- Carry out the points above on the cutter with the tongue knife, so that it is placed at the same height above the table.
- Test-plane a small board, and check that the tongue and groove are at the right height in relation to one another.

Alternatively, the knife can be set arbitrarily, after which a test bit is run. Measure the test bit and correct the knife height.



**IMPORTANT!** Spacers must also be placed above the cutter so that it is fixed on the spindle. Add some of the distance rings that are not used for height setting, so that the thickest ring lies highest and protrudes several millimeters above the lowest threads on the threaded bar. Then screw the nuts on the threaded bar and tighten properly.

## GRINDING

To sharpen the knife, you can grind the flat side of the knife. Always grind the knives in pairs, so that they have the same weight, otherwise vibrations could occur in the cutter.

If the profile of the knife is damaged, this should be re-ground by a professional knife sharpener. This is a service that is normally available locally, otherwise contact Wood-Mizer.



## ADJUSTING THE FENCE BY CUTTER 2

See Figure 3-13.

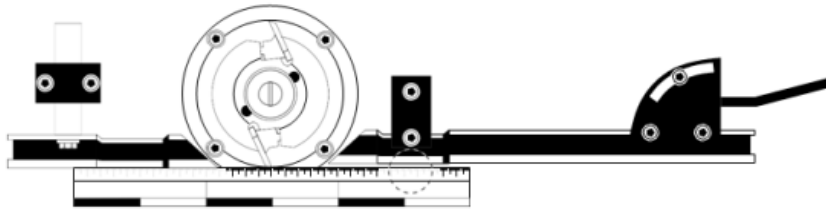

FIG. 3-13

### In general

The front side fence has a double set of holes for assembly. It can therefore be assembled in two basic positions. When the TB90 system is used, the fence will be fitted in the pair of holes on the right, as seen from the infeed side (see assembly of side fence). When cutters with larger diameters are used, the fence can be moved to the left pair of holes, so that the stroke length is sufficient.

The fixed cutter has two fences, the front (62) and the back fence (54). The front fence controls how much the cutter cuts, and the back fence works as a support for the workpiece when it has passed cutter 2 and is ready to be worked by cutter 3.

Both fences must be in line with one another, but offset in parallel so that the front fence is slightly more to the right (see fig.). In this way, the back fence will support the workpiece once it has been cut by cutter 2 (the workpiece is slightly smaller then).

The fence is fixed by socket head screws in the fence holders (55) according to fig. The screws that lock the fence in the horizontal direction are 13 mm (5/10") hexagonal screws and sit in the fence's U profile. In addition, there are micro adjustments on the fence. When the hexagonal screws are loosened slightly, the knob for micro-adjustments can be turned. If the angle of the fence needs to be adjusted, both the hexagonal and socket head screws must be loosened.

## INSTALLATION OF SIDE FENCES

### Method 1:

- Insert the first fence inwards, for minimal cutting. Add a straight aluminum fence rail tight against the fence. Adjust the fence using the lever until the loose fence rail touches the cutter's plane diameter (the outer rotating line) as it lies against the first fence.
- The plane diameter that is in line with the back fence is where you need to measure to, the cutter's plane diameter that is higher than 30 mm above the table height is unimportant here.
- Align the back fence along the guard rail, which is still tight against the first fence and tighten it. The cut is now 0 mm. The first fence, cutter and back fence are fully in line, and the first fence controls the angle through the machine.
- Remove the fence rail and all loose tools from the machine.

- Move the first fence back to the required cut and lock it using the tie-back knob. (Around 2 mm is usually a suitable cut for the first cutter.)

#### Method 2:

- The back fence is pulled in so that it is not used, and is fixed there. (Check that the cutter can rotate freely.)
- Position the front fence so that the required cut depth is obtained and the fence stands straight. Tighten the screws that fix the fence.
- Close the safety doors and take the measures required to start the planer/moulder.
- Start the bottom cutter, both side cutters and the feeder and feed in a test piece of approx. 1 meter (3 ft). Stop the planer/moulder just as the board reaches the moveable cutter (cutter 3).
- Drive the back fence towards the planed part of the board.

See Figure 3-14.



FIG. 3-14

- Check that the test piece is lying against both fences and tighten the back fence's lock screws.



**IMPORTANT!** Check that all screws that fix the fences are properly tightened, and that the cutter can rotate freely.

**TIP:** If there is a problem in that the board does not follow the fences, it could be that the back fence is not at the right level in relation to the cutter, that the fences are not completely parallel to one another, or that the fence does not run straight through the planer/moulder. If it is difficult to get the fence to lie perfectly straight through the planer/moulder, it is better that the fences are slightly angled to the left, towards cutter 3, as the feed rollers will then press the workpiece against the fence. If the fences lie at a slight angle to the right, away from cutter 3, the feed rollers will pull the object away from the fence, which will lead to incorrect measurements and a badly planed surface.

#### ADJUSTING THE SIDE, MOVEABLE CUTTER

Loosen the lock handle (A) that is located on the slide under the table and/or the slotted screw (B) that is located above the slide. Then insert the crank (C) onto the threaded rod on the side of the planer and move the side cutter head to the required planing width. One rotation of the crank is 4 mm.

Measure the distance between the cutter knives and the back fence with sliding caliper. This measurement becomes the width of the finished board. Fix this position with the lock handle under the table.

### INDICATOR

The indicator (D) shows the width measurement in mm in black, and 1/10 mm in red. Each time, when setting to a new profile: plane a board, measure the outer measurements with the sliding caliper. Turn the small handle to the right of the indicator so this measurement is shown in the window.

See Figure 3-15.

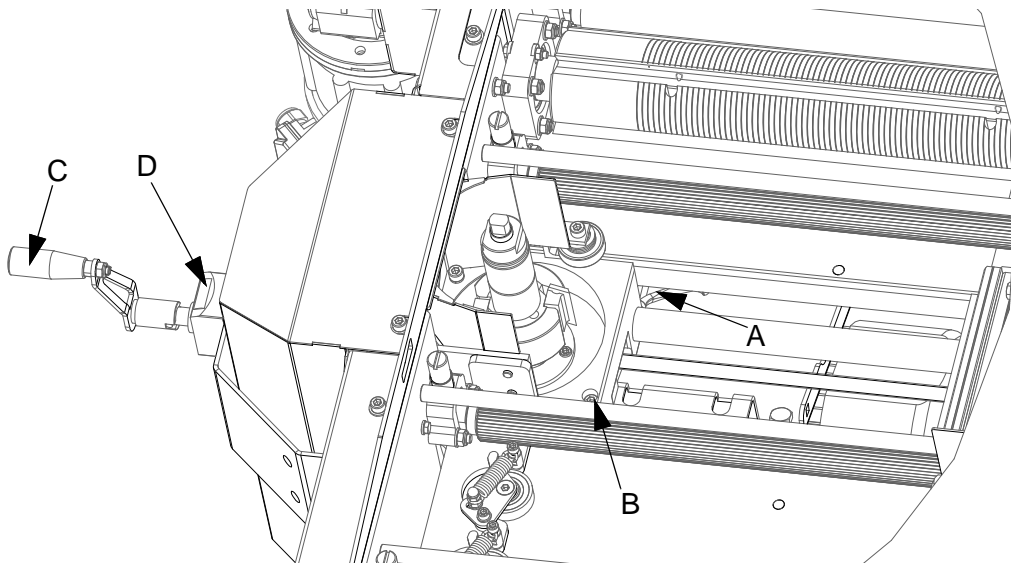
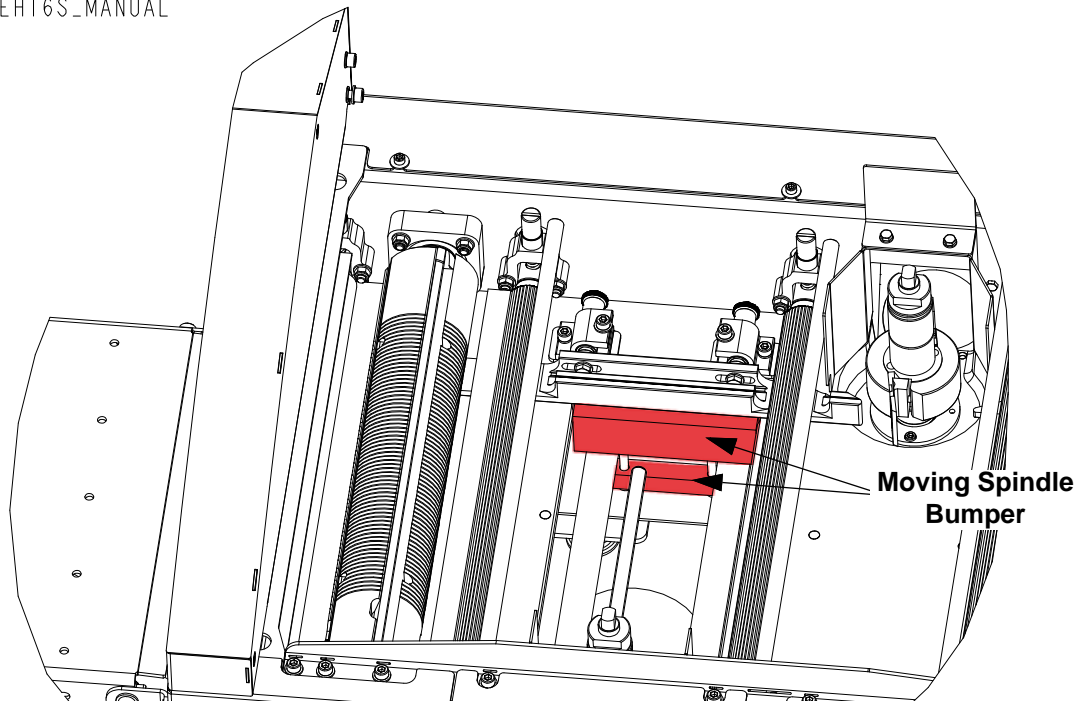

FIG. 3-15

**See Figure 3-16.** In order to obtain the smallest cutting width, dismount the moving spindle bumper parts (Part No. 536956-1 & 536957-1) before positioning the moving spindle. The moving spindle bumper serves as the basis for a constant cutting size.

MP360EH16S\_003  
MP360EH16S\_MANUAL



**FIG. 3-16**

Chip breaker - mounting instructions:

Unscrew the M8x16 screws (A). Then place the chip breaker (B) in the place shown in the figure. Secure with the previously unscrewed screws.

See Figure 3-17.

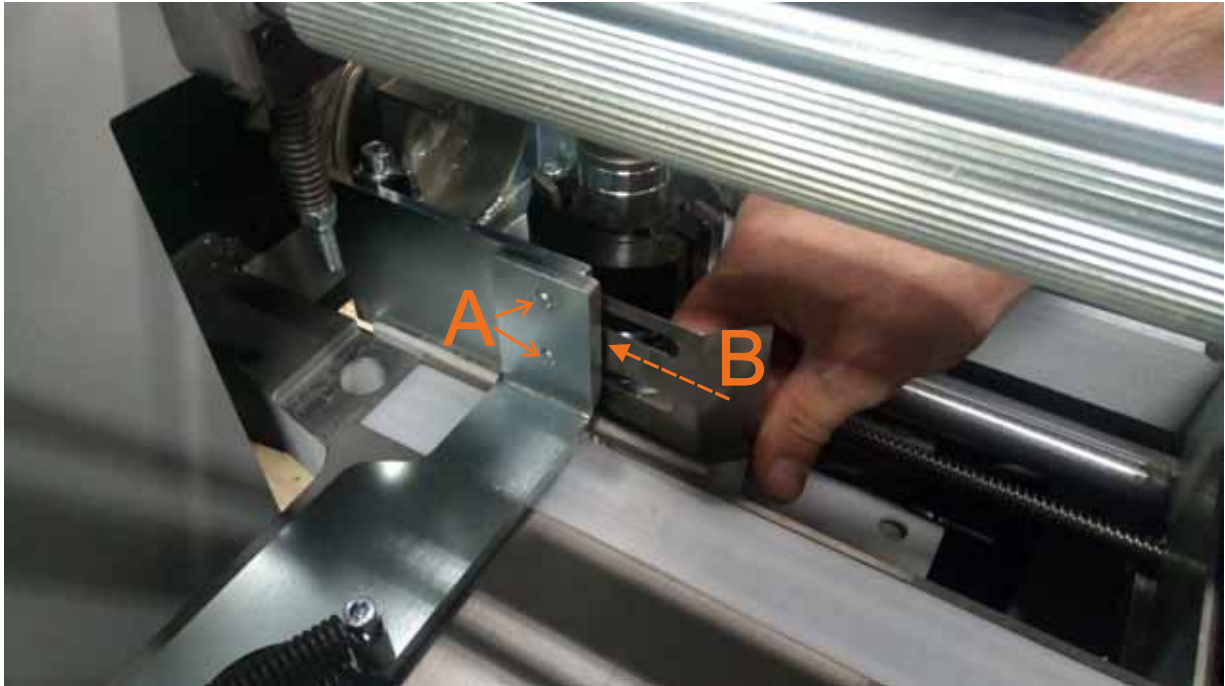

FIG. 3-17

### INSTALLING A PRESSURE ROLLER FOR MOVEABLE CUTTERS

Two pressure rollers are located in front of the moveable cutter, to press the workpiece towards the fence. By adjusting this you can also decide how wide the workpieces fed into the planer/ moulder can be. These pressure rollers sit on an arm (77) that is anchored in the moveable cutter's slide, which means that they move with the cutter when this is adjusted.

To set the pressure rollers, loosen the socket head screws that fix the arm in the moveable cutter's slide with a 6 mm hex wrench. Adjust the arm so that the press rollers are pressed in by approx. 5 mm when the workpiece is fed into the planer. A spring plate (supplied on delivery) can be mounted in front of the moveable cutter between the press rollers' arm and screw plate. The spring plate has oval holes that allow adjustment in and out from the workpiece. The spring plate works partly as a tension control, but also as a fence in front of the cutter which reduces the risk of long splinters being knocked out of the workpiece during large cuts.

Adjust the feather plate so that it is pushed in to a couple of millimeters from the unplanned edge of the workpiece.



**IMPORTANT!** Check that there is no risk of the spring plate pushing into the cutter's knife if you are planing an object of variable width. Maintain a safety margin of at least one centimeter in the pressed in position.

# 3

## SETUP & OPERATION

### Variable speed motor

After the moveable cutter, there is another pressure roller (76) which pushes the cut workpiece towards the back fence. Set the pressure roller so that it protrudes approx. 1-3 mm from the cutter's smallest plane diameter, at the same height as the pressure roller.

The height of the pressure roller can also be set with washers above or below it. Which may be required for producing certain profiles.

### TEST RUN

Always run a test piece and make subsequent adjustments. Run a piece straight through the planer at the slowest feed speed. Look through the cover while it is being planed and check that the board is lying against the fences in front of and behind cutter 2.

Then measure the profile, its height and width, and subsequently adjust the cutters and the setting for the molding knives if required.

### 3.3.6 Variable speed motor



**WARNING!** Do not turn feed speed adjustment knob when the feed is off or material is planing/moulding.

### ASSEMBLY (IF VARIABLE SPEED MOTOR IS MOUNTED IN PLACE)

Mount feed motor on the last feed roller shaft (A). Be sure to mount the cover (B) properly (so that the key in the bottom of the cover fits the slot (C) in moulder's body). Use the lock screw (D) to secure the motor on the roller shaft.

See Figure 3-18.

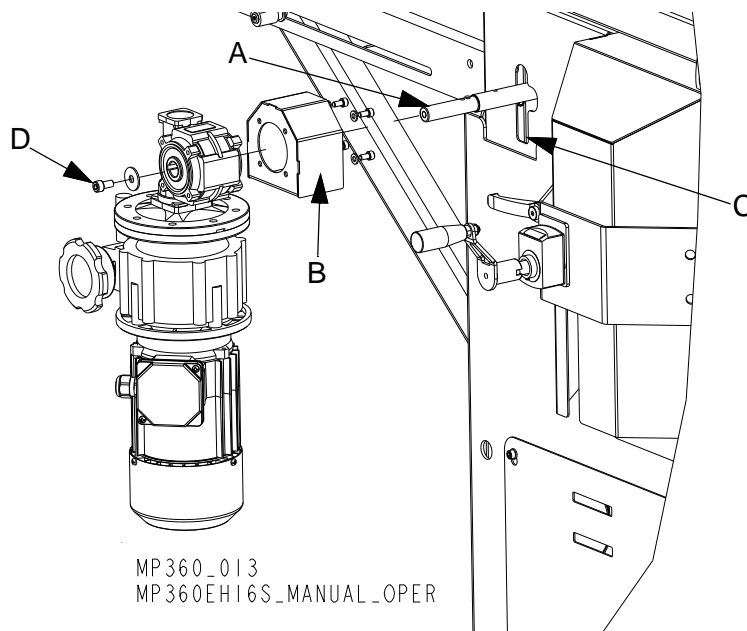

FIG. 3-18

**SETTING THE FEED SPEED**

To set the feed speed use the knob located on the feed gear when the feed rollers are running. To increase the speed turn the knob right, to decrease - turn left.

**MAINTENANCE**

Fluid should be visible in the fluid inspection window. Fluid level should be checked when feed gear is not working.

Fluid should be refilled when it is not visible in the inspection window. Use oil for automatic gearboxes or compatible oil according to the table below.

The variator is filled with AGIP BLASIA 32 oil at the factory and does not normally require an oil change during its life.

The worm gear oil does not normally need changing or topping up during the life of the gear.

**See table 3-2.** Recommended oil types.

AGIP	BLASIA 32
SHELL	A.T.F DEXRON
ESSO	A.T.F DEXRON
MOBIL	A.T.F 220
CASTROL	DEXTRON II
BP	AUTRAN DX

**TABLE 3-2**

■

## SECTION 4 MAINTENANCE

This section lists the maintenance procedures that need to be performed.



**CAUTION!** Always disconnect and lock out power supply before performing any maintenance work, cleaning or servicing the planer/moulder. Failure to do so may result in serious injury.



**This symbol** identifies the interval (hours of operation duty) at which each maintenance procedure should be performed.

### 4.1 Wear life

**See Table 4-1.** Estimated life expectancy of common replacement parts is given in table below. This information is provided so that you may plan ahead in ordering replacement parts. This chart lists estimated life expectancy of common replacement parts if proper maintenance and operation procedures are followed. Due to many variables which exist during machine operation, actual part life may vary significantly.

Part description	Estimated life
Drive belt	1250 hours

**TABLE 4-1**

### 4.2 Sawdust Removal



Remove the excess sawdust and chips from the inside and outside of the planer/moulder using compressed air and brush every eight hours of operation.

### 4.3 Miscellaneous Maintenance



1. Oil all chains with Dexron III ATF every fifty hours of operation.



**CAUTION!** Do not use chain lube. It causes sawdust buildup in chain links.

2. Clean resin from the table. Use solvent if necessary. Lubricate table e.g. with paraffin oil.



3. Lubricate these parts every 50 oils:

- Feed roller bushing,
- Sprockets
- Table height adjustment chain



- Feed roller drive chain
- Two slide rods and trapezoidal thread
- Cast iron table

50 **4.** Every 50 hours check that all screws and bolt connections are tightened. Check that cables and electrical connectors are in good condition.

## 4.4 Drive Belts Tension Adjustment

### 4.4.1 Top cutter drive belt tension adjustment

50 Check top cutter drive belt tension after first 20 hours of operation and every 50 hours of operation thereafter.

1. Unbolt and remove top cutter drive belt cover (A).
2. Check top cutter drive belt for wear and tension. Replace belt as needed.
3. To tension the drive belt, loosen motor plate mounting bolt (B).

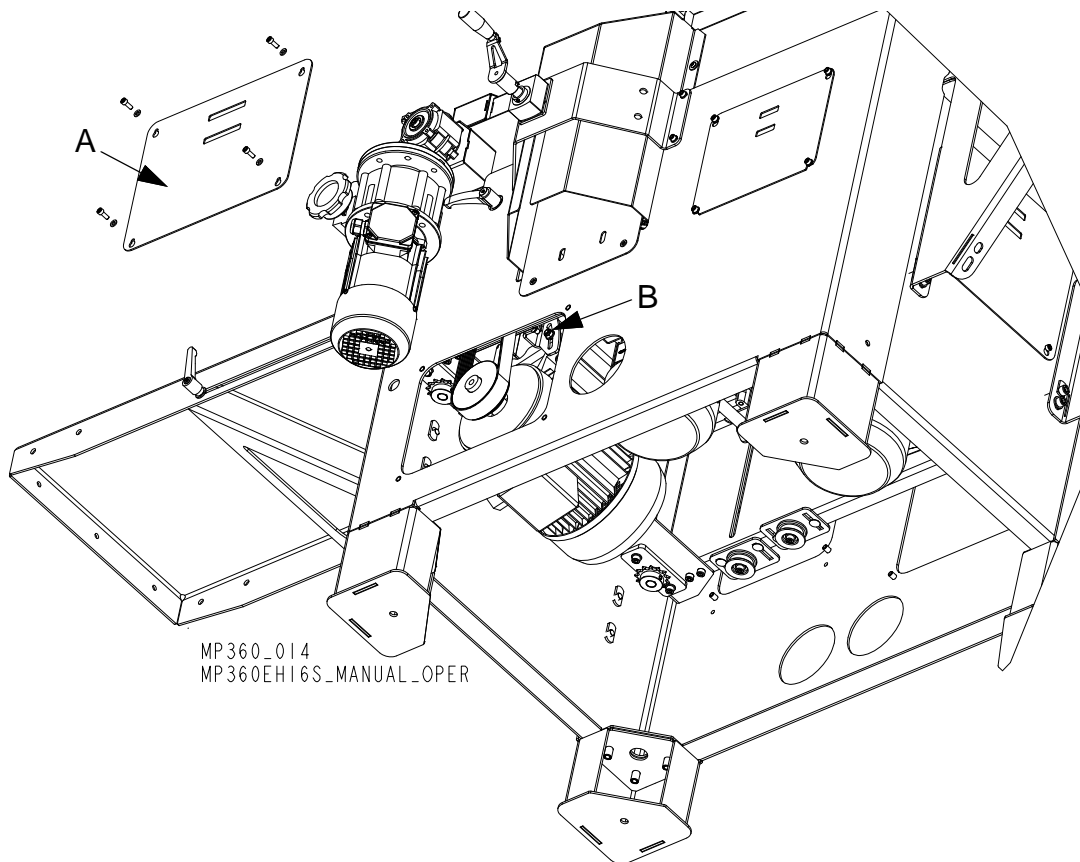

**FIG. 4-1**

4. Move motor with mounting plate to adjust properly drive belt. Next tighten motor plate mounting bolts. Mount top cutter drive belt cover.
5. Check motor and top cutter pulleys alignment. Both pulleys should be in line to avoid premature drive belt wear. Loosen set screw on the shaft to move pulleys. After pulleys alignment, recheck the belt tension.

#### 4.4.2 Bottom cutter drive belt tension adjustment

50

Check bottom cutter drive belt tension after first 20 hours of operation and every 50 hours of operation thereafter.

1. Unbolt and remove bottom cutter drive belt cover (A).
2. Check bottom cutter drive belt for wear and tension. Replace belt as needed.
3. To tension the drive belt, loosen motor plate mounting bolt (B).

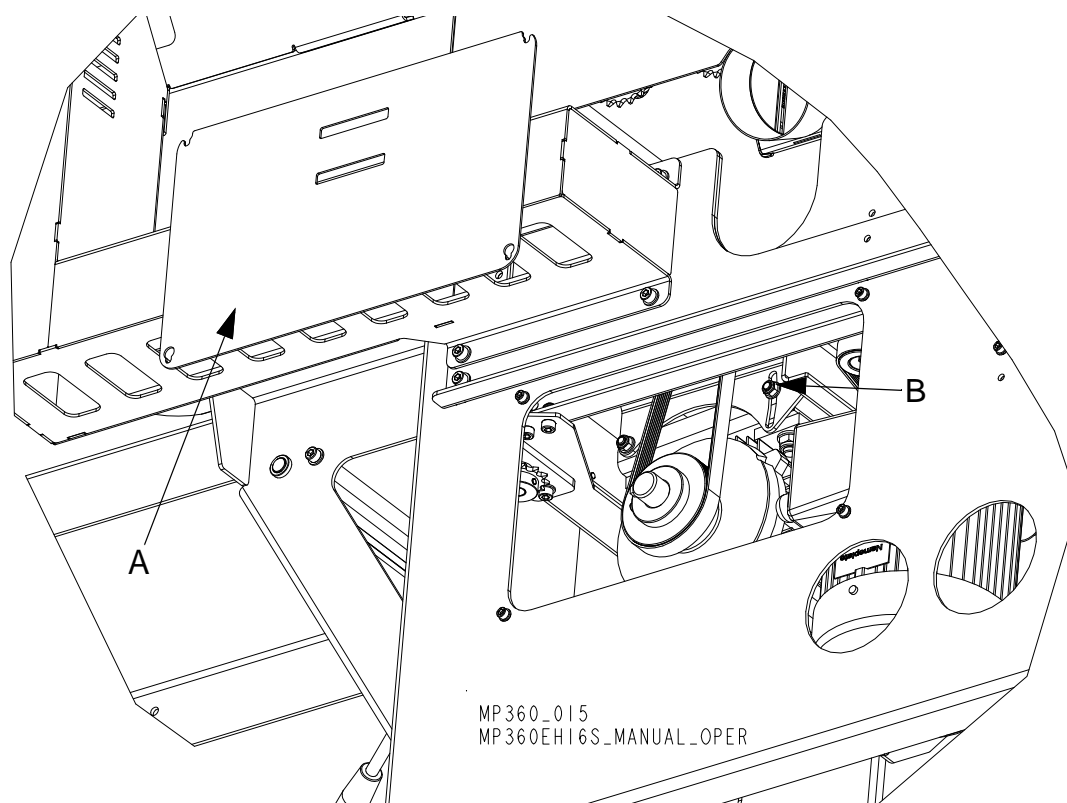

FIG. 4-2

4. Move motor with mounting plate to adjust properly drive belt. Next tighten motor plate mounting bolts. Mount bottom cutter drive belt cover.
5. Check motor and bottom cutter pulleys alignment. Both pulleys should be in line to avoid premature drive belt wear. Loosen set screw on the shaft to move pulleys. After pulleys alignment, recheck the belt tension.

#### 4.4.3 Side, fixed cutter drive belt tension adjustment

Dismount both side covers (A, B). Loosen four motor mounting bolts (C). Use adjustment bolt D to adjust belt tension.

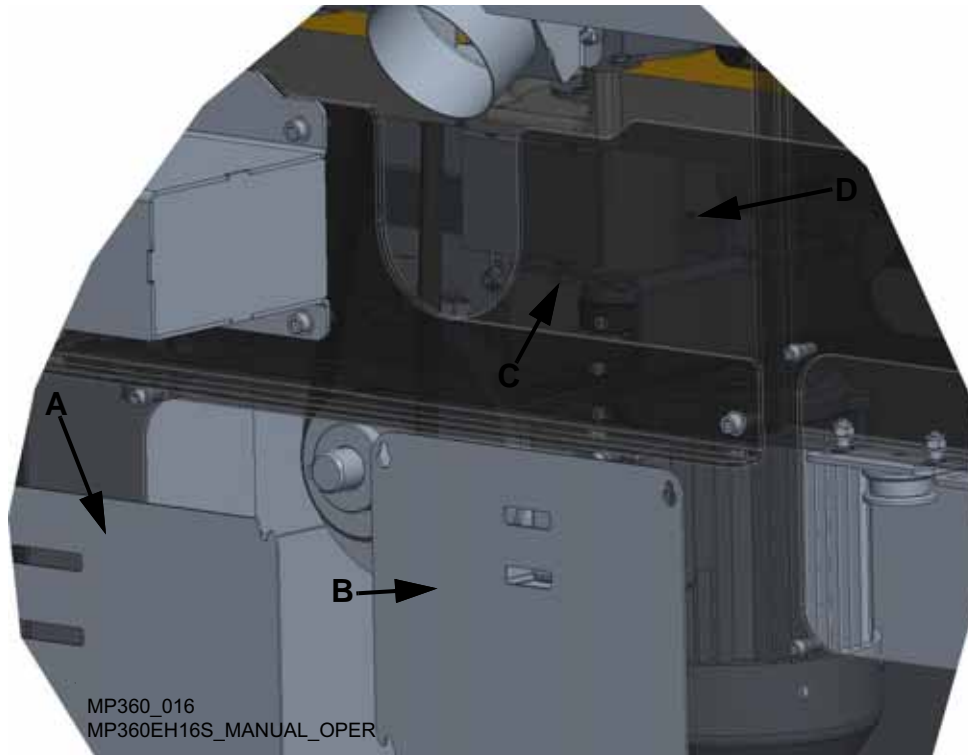

FIG. 4-3

#### 4.4.4 Side, moveable cutter drive belt tension adjustment

Dismount both side covers (A, B). Loosen four motor mounting bolts (C). Use adjustment bolt D to adjust belt tension.

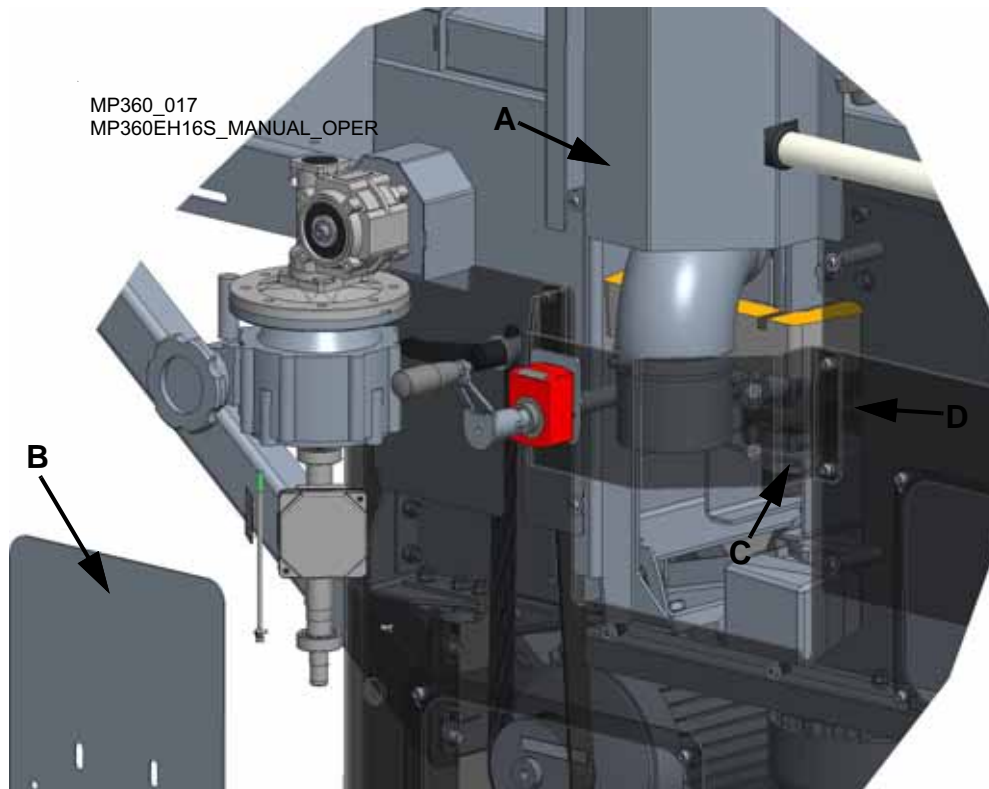

FIG. 4-4

#### 4.4.5 Table chain tension adjustment

[See Section 3.3.4 Chain transmission with trapezoidal thread adjustment](#)

## 4.5 Long-term storage

If the machine is not used for a long period of time, do as follows:

- Disconnect the power cord.
- Perform all routine actions described above.
- Remove the knives with mounting strips or clamping wedges and store them well lubricated in above zero temperature.
- Loosen the motor belt tension.
- Spray a thin layer of anti-rust coating (such as P.D.R.P) onto the places not protected against rusting.
- Store the machine in a well ventilated room.
- Cover the planer/moulder.

## 4.6 Replacement of Inserts in Helical Cutterhead



**CAUTION!** Inserts have sharp edges. Always use protective gear and remain cautious when replacing inserts. Failure to do so may result in serious injury.

Inserts have four cutting edges. If one of the cutting edges becomes dull the insert can be rotated 90 degrees. If the insert is damaged or worn out it should be replaced. Replacement procedure is shown below.

1. Remove the screw (A) with torx screwdriver.
2. Remove or rotate the insert (B).
3. Tighten the screw removed in step one

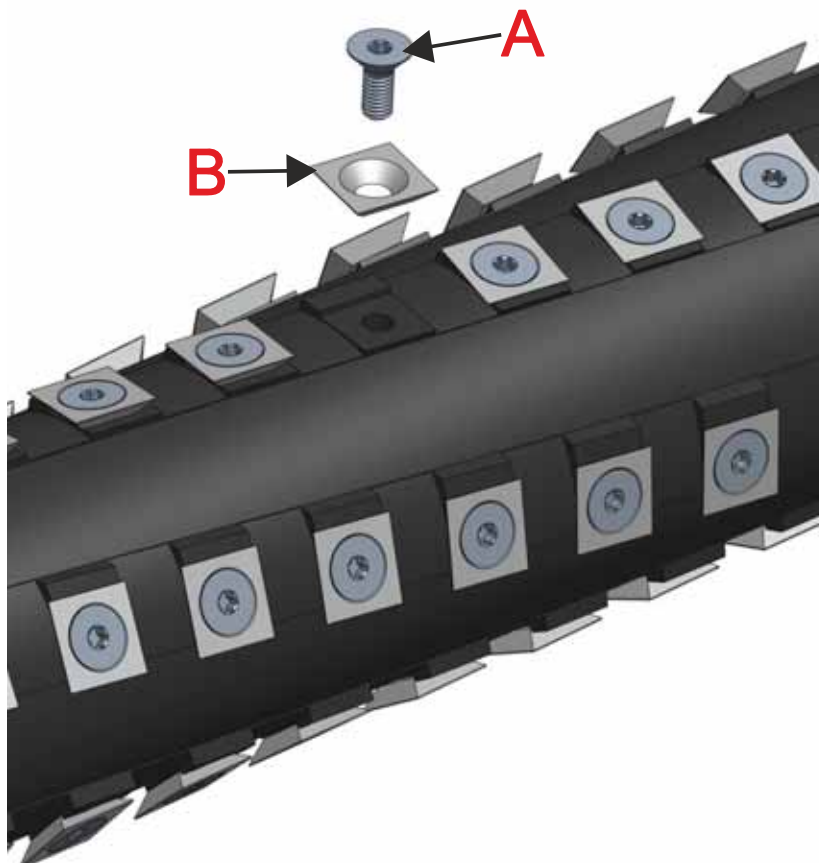

FIG. 4-5

## 4.7 Safety Devices Inspection

### *Moulder – Safety Devices Inspection*

Safety devices on the machine which must be checked before every shift:

- E-STOP button and its circuit inspection,
- Cutter cover safety switch and its circuit inspection.
- Protective plate with limit switch and its circuit inspection.

#### 1. E-STOP button and its circuit inspection

- Use “I” buttons to start all cutters and next feed rollers. The motors should start.
- Press the E-STOP button located on the control box. All motors should be stopped. Pressing any of “I” buttons should not start any motor until the E-STOP button is released.



**FIG. 4-6**

#### 2. Cutter cover safety switch and its circuit inspection



**CAUTION!** Use extreme caution when opening cutter housing cover if any of the cutters are working (to inspect safety devices).

- Be sure the emergency switch button is released;
- Use “I” buttons to start all cutters and next feed rollers. The motors should start.
- Open the cutter housing cover;
- All motors should be stopped.
- Pressing any of “I” buttons should not start the motors.

- Close the cutter housing cover.
- Motors should remain stopped until they are restarted with any of “I” buttons.

### 3. Protective plate with limit switch and its circuit inspection.

- Be sure the emergency switch button is released;
- Use “I” buttons to start all cutters and next feed rollers. The motors should start.
- Using a board or cant push the protective plate (A).
- All motors should be stopped.
- Back the board or cant.
- Motors should remain stopped until they are restarted with any of “I” buttons.

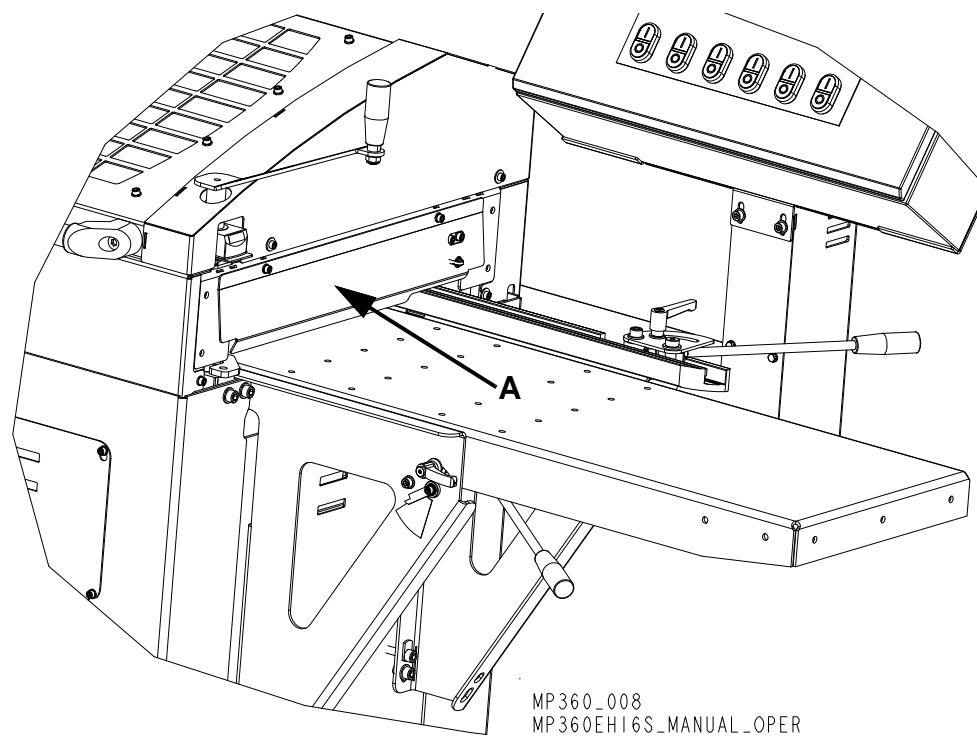

FIG. 4-7



## SECTION 5 PLANER/MOULDER SPECIFICATIONS

### 5.1 Overall dimensions

See figure 5-1. The overall dimensions of the MP360 Planer/moulder are shown below (all dimensions in millimeters).

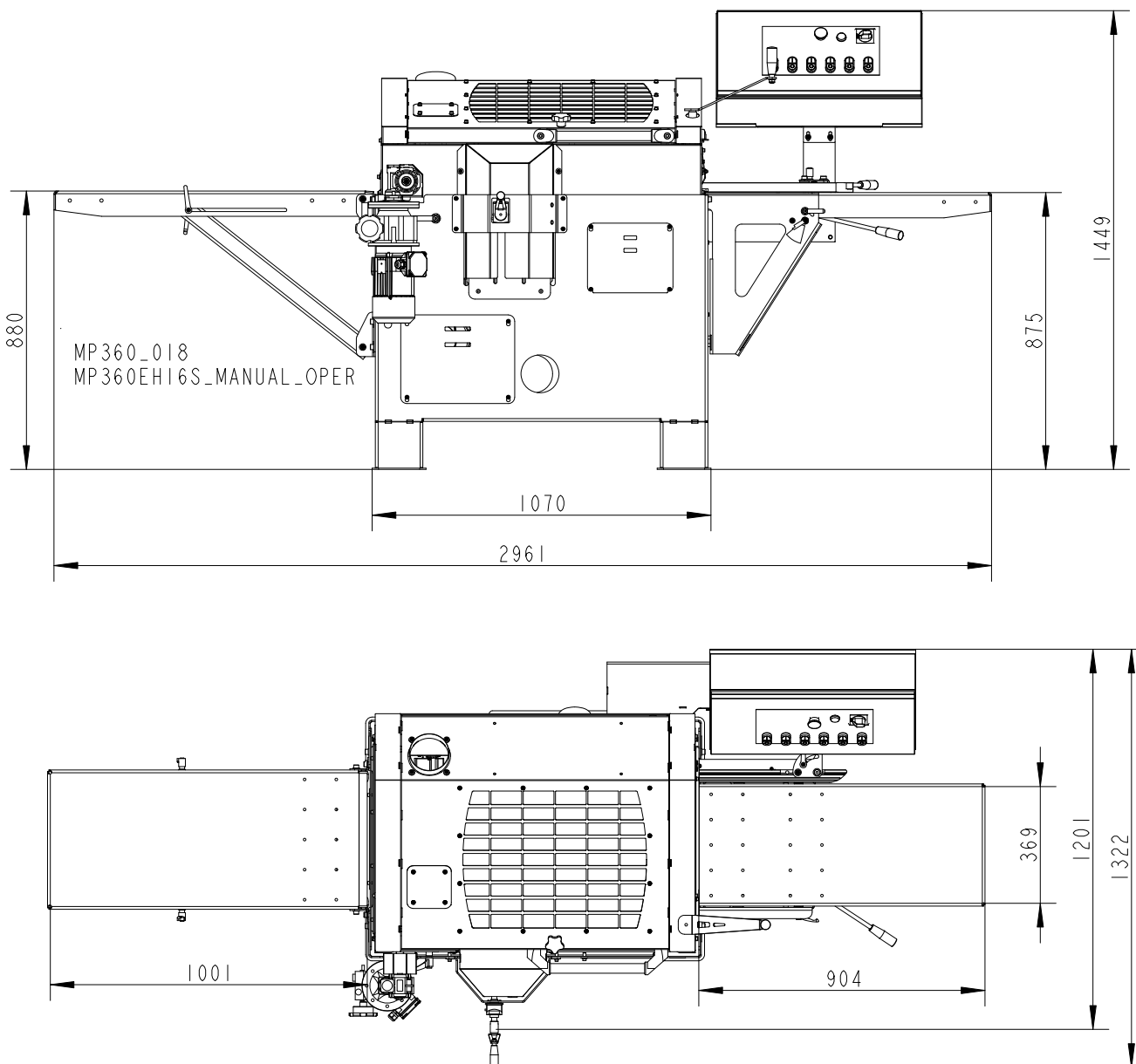

FIG. 5-1 MP360

# 5 PLANER/MOULDER SPECIFICATIONS

## Overall dimensions

See figure 5-2.

MP360\_019  
MP360EH16S\_MANUAL\_OPER

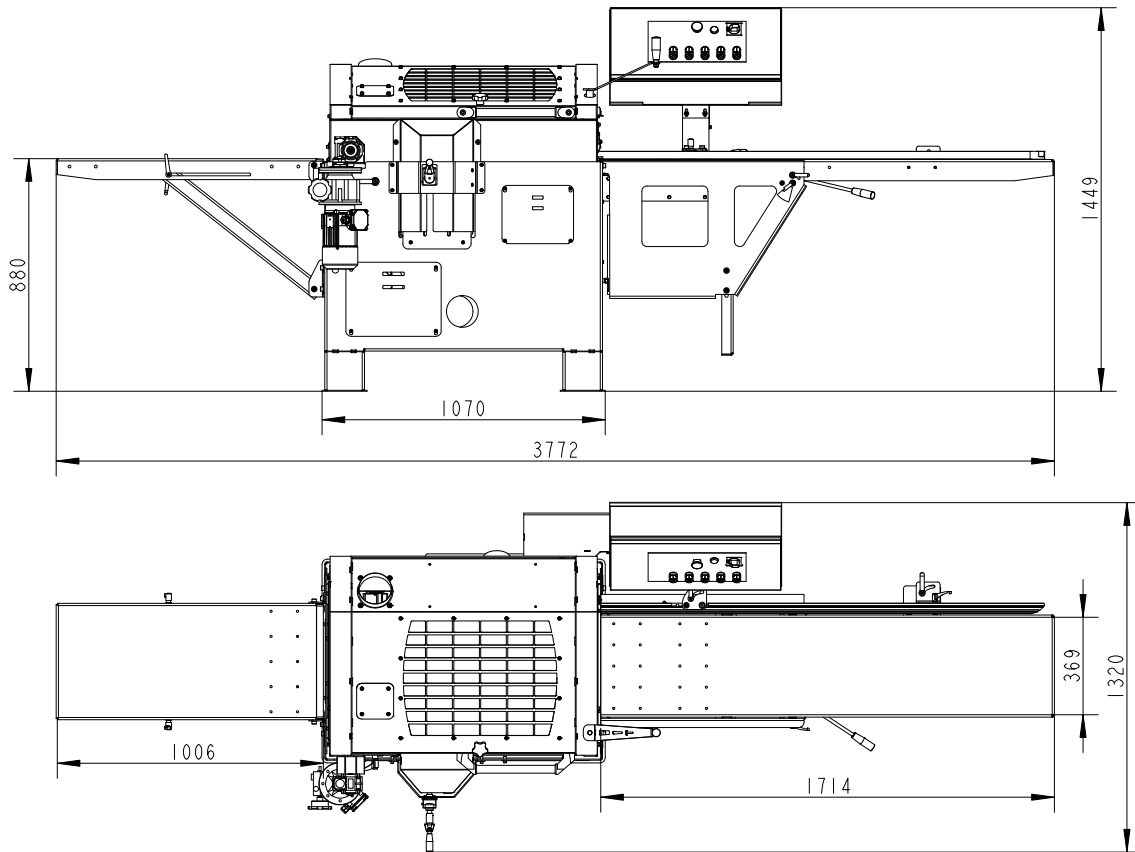

FIG. 5-2 MP360

See table 5-1. Weight of the MP360 planer/moulder are given in the table below.

Planer/moulder type	MP360
Weight	675 kg
Weight with transport box	740 kg

**TABLE 5-1**

## 5.2 Specifications of the planer/moulder

See table 5-2. Wood-Mizer MP360 planer/moulder nomenclature is given in the table below.

	Volts
MP360EB16S	3 ph 230V, CE Standard
MP360EB16U	3 ph 230V, UL Standard
MP360EC16U	3 ph 460V, UL Standard
MP360EH16S	3 ph 400V, CE Standard

**TABLE 5-2**

See table 5-3. See the table below for specifications of the MP360 planer/moulder motors.

MP360EH16S					
	Upper cutter motor specifications	Lower cutter motor specifications	Side, fixed cutter motor specifications	Side, movable cutter motor specifications	Feed motor specifications
Motor Type	Electric Motor	Electric Motor	Electric Motor	Electric Motor	Electric Motor
Rated Voltage	3x400V	3x400V	3x400V	3x400V	3x400V
Rated motor revolutions	2900 r.p.m.	2900 r.p.m.	2900 r.p.m.	2900 r.p.m.	2780 r.p.m.
Rated cutter revolutions	6000 r.p.m.	6000 r.p.m.	6000 r.p.m.	6000 r.p.m.	---
Rated power	5,5kW	4kW	3kW	3kW	0,75kW
Wood-Mizer Part #	537388	537387	537385	537385	532808

**TABLE 5-3**

MP360EB16S					
	Upper cutter motor specifications	Lower cutter motor specifications	Side, fixed cutter motor specifications	Side, movable cutter motor specifications	Feed motor specifications
Motor Type	Electric Motor	Electric Motor	Electric Motor	Electric Motor	Electric Motor
Rated Voltage	3x230V	3x230V	3x230V	3x230V	3x230V
Rated motor revolutions	2900 r.p.m.	2900 r.p.m.	2900 r.p.m.	2900 r.p.m.	2780 r.p.m.

**TABLE 5-3**

# 5 PLANER/MOULDER SPECIFICATIONS

Specifications of the planer/moulder

Rated cutter revolutions	6000 r.p.m.	6000 r.p.m.	6000 r.p.m.	6000 r.p.m.	---
Rated power	5,5kW	4kW	3kW	3kW	0,75kW
Wood-Mizer Part #	537388	537387	537385	537385	532808

TABLE 5-3

MP360EC16U								
	Upper cutter motor specifications	Lower cutter motor specifications	Side, fixed cutter motor specifications	Side, movable cutter motor specifications	Feed motor specifications	Current (FL)	Current (LL)	SCCR
Motor Type	Electric Motor	Electric Motor	Electric Motor	Electric Motor	Electric Motor	38	9,4	5kA
Rated Voltage	3x460V	3x460V	3x460V	3x460V	3x460V			
Rated motor revolutions	3480 r.p.m.	3480 r.p.m.	3480 r.p.m.	3480 r.p.m.	3340 r.p.m.			
Rated cutter revolutions	7100 r.p.m.	7100 r.p.m.	7100 r.p.m.	7100 r.p.m.	---			
Rated power	5,5kW	4kW	3kW	3kW	0,75kW			
Wood-Mizer Part #	537388-UL	537387-UL	537385-UL	537385-UL	532808-UL			

TABLE 5-3

MP360EB16U								
	Upper cutter motor specifications	Lower cutter motor specifications	Side, fixed cutter motor specifications	Side, movable cutter motor specifications	Feed motor specifications	Current (FL)	Current (LL)	SCCR
Motor Type	Electric Motor	Electric Motor	Electric Motor	Electric Motor	Electric Motor	68	18,7	5kA
Rated Voltage	3x230V	3x230V	3x230V	3x230V	3x230V			
Rated motor revolutions	3480 r.p.m.	3480 r.p.m.	3480 r.p.m.	3480 r.p.m.	3340 r.p.m.			
Rated cutter revolutions	7100 r.p.m.	7100 r.p.m.	7100 r.p.m.	7100 r.p.m.	---			
Rated power	5,5kW	4kW	3kW	3kW	0,75kW			
Wood-Mizer Part #	537388-UL	537387-UL	537385-UL	537385-UL	532808-UL			

TABLE 5-3

See table 5-4. Feed rate

Planer/moulder type	MP360EH16S
Feed Speed	6-15 m/min

TABLE 5-4

See table 5-5. The noise level generated by Wood-Mizer planer/moulder is given in the table below<sup>1 2 3</sup>

	Noise Level
Planer/Moulder MP360 Equipped with electric motor	L <sub>pA</sub> = 85,6 dB (A) L <sub>wA</sub> = 101,3 dB (A)

TABLE 5-5



**IMPORTANT!** The total value of hand-arm vibration the operator may be exposed to does not exceed 2.5 m/s<sup>2</sup>. The highest root mean square value of weighted acceleration to which the whole operator's body is subjected does not exceed 0.5 m/s<sup>2</sup>.

See table 5-6. See the table below for planing/moulding material specifications.

	One-sided planing	Double-sided planing	Four-sided planing
Minimum Cant Height	--	10 mm	10 mm
Minimum Cant Width	10 mm	10 mm	15 mm
Maximum Cant Height	220 mm	220 mm	160 mm
Maximum Cant Width	510 mm	410 mm	350 mm

TABLE 5-6

1. The noise level measurement was taken in accordance with PN-EN ISO 3746 Standard . Value for associated uncertainty K=4dB.

2. The measured values refer to emission levels, not necessarily to noise levels in the workplace. Although there is a relation between emission levels and exposure levels, it is not possible to determine with certainty if preventives are needed or are not needed. Factors that influence the actual level of exposure of the workforce include the characteristics of the work room and the other sources of noise etc. i.e. the number of machines and other adjacent processes. Also, the permissible exposure level value may vary depending on country. This information enables the machine's user to better identify hazards and a risk.

3. The total value of hand-arm vibration the operator may be exposed to does not exceed 2.5 m/s<sup>2</sup>. The highest root mean square value of weighted acceleration to which the whole operator's body is subjected does not exceed 0.5 m/s<sup>2</sup>.

# 5 PLANER/MOULDER SPECIFICATIONS

## Specifications of the planer/moulder

See table 5-7. Other specifications of the planer/moulder are listed below

Cutter Specifications	
Number of knife sockets	4
Upper cutter diameter	88 mm
Upper cutter width	510 mm
Upper cutter max. planing depth	8 mm
Upper cutter max. moulding depth	20 mm
Lower cutter diameter	72 mm
Lower cutter width	410 mm
Lower cutter max. planing depth	8 mm
Lower cutter max. moulding depth	10 mm
Side cutter diameter	90 mm
Maximum Height	40 mm
Side cutter max. planing depth	30 mm
Cutter rotations	6000 r.p.m.
Knives Specifications	
Straight knife height "A"	20 mm
Straight knife thickness "B"	3 mm
Straight knife protrusion "C"	1 mm
Pattern knife protrusion "C"	depends on the knife thickness (see table 5-8)

TABLE 5-7

See figure 5-3.

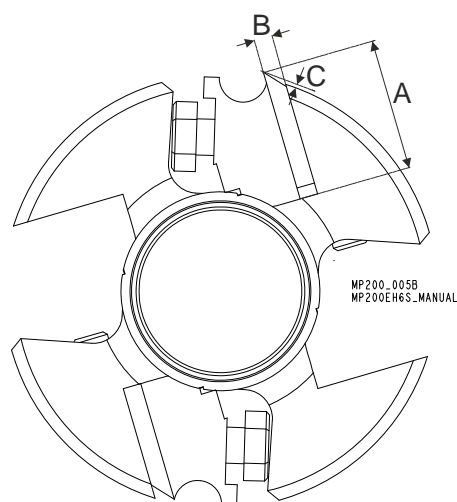

FIG. 5-3

See table 5-8. A relation between the pattern knife protrusion and the thickness is shown below.

Pattern knife thickness	Pattern knife max. protrusion <sup>1</sup>
3 mm	13 mm
4 mm	21 mm
5mm	29 mm

TABLE 5-8

<sup>1</sup> According to EN 847-1:2005 European Standard

### 5.3 Dust/Chip Extractor Specifications

See Table 5-9. Specifications of the dust/chip extractors used on the MP360 are listed below.

Airflow	5000 m <sup>3</sup> /h
Inlet diameter	3x100mm 1x125 mm
Motor power	4 kW
Number of sacks	1-2 pcs
Sack capacity	--
Recommended conveying air velocity in the duct	25 m/s

TABLE 5-9

The pressure drop between the inlet of the capture device and the connection to the CADES should be maximum 1,5 kPa (for the nominal air flow rate). If the pressure drop exceeds 1,5 kPa the machine might not be compatible with conventional CADES.



**IMPORTANT!** The dust extractor hoses must be grounded or made with materials not accumulating electrostatic charge.



**CAUTION!** Always turn on the dust extractor before starting the machine.

## EC declaration of conformity according to EC Machinery Directive 2006/42/EC, Annex II, 1.A

**Manufacturer:** Wood-Mizer Industries sp. z o.o.  
Nagórna 114, 62-600 Koło; Poland  
Tel. +48 63 26 26 000

This declaration of conformity is issued under the sole responsibility of the manufacturer.

Following machine in our delivered version complies with the appropriate essential safety and health requirements of the EC Machinery Directive 2006/42/EC based on its design and type, as brought into circulation by us. In case of alteration of the machine, not agreed by us, this declaration is no longer valid.

### We, the undersigned herewith declare, that:

Designation of the machine: **Four-sided planer-moulder Wood-Mizer MP360**

Type: MP360

Models: MP360EH16S, MP360EB16S

Serial Number: .....

### Is in conformity with the following EC directives:

EC Machinery Directive 2006/42/EC  
EC Electromagnetic Compatibility Directive  
2014/30/EC

### And is in conformity with the following Harmonized Standards:

PN-EN 12100:2012;  
PN-EN ISO 13849-1:2016-02  
PN-EN 60204-1:2018-12

Responsible for Technical Documentation: Piotr Adamiec / Engineering Manager  
Wood-Mizer Industries Sp. z o.o.  
62-600 Koło, ul. Nagórna 114, Poland  
Tel. +48 63 26 26 000

Place/Date/Authorized Signature:

Koło, 01.10.2020



Title :

Engineering Manager



