

# **Wood-Mizer®**

## **Parts Manual**

---

**MP200 E6S**

**rev. A1.07**

**MP200 E7S-V**

**rev. A1.07**

---



**Safety is our #1 concern!** Read and understand all safety information and instructions before operating, setting up or maintaining this machine.

*Form #2401*

# Table of Contents

# Section-Page

<b>SECTION 1</b>	<b>GENERAL INFORMATION</b>	<b>1-1</b>
1.1	How To Use the Parts List.....	1-1
1.2	Sample Assembly .....	1-1
<b>SECTION 2</b>	<b>PLANER/MOULDER, MP200</b>	<b>2-1</b>
2.1	Shafts .....	2-1
2.2	Side Covers .....	2-2
2.3	Front Cover .....	2-3
2.4	Insert & glide .....	2-4
2.5	Decals .....	2-5
2.6	MP200 Additional Part Kit .....	2-7
2.7	MP200 Knives .....	2-8
2.8	Foot Set (No. 536996) .....	2-9
2.9	Front Plate 533127 .....	2-10
2.10	Castor wheels 535166 .....	2-11
2.11	Castor wheel assembly 535163 .....	2-12
2.12	Left Cover 533130 .....	2-13
2.13	Anti-kickback Fingers Assembly 533125 .....	2-14
2.14	Fence Assembly 533535 .....	2-15
2.15	Fence Assembly - Optional (564884) .....	2-17
2.16	Table, MP200 533545 .....	2-19
2.17	Press Roller Assembly 533550 .....	2-21
2.18	Cutter Guard Assembly 533507 .....	2-22
2.19	Upper Guard 533567 .....	2-23
2.20	Round Scale (No. 533676) .....	2-24
2.21	Flexible Guard (533729) .....	2-25
2.22	Infeed Table 533095 .....	2-26
2.23	Outfeed Table Extension (No. 546935) .....	2-27
2.24	Material Guide Assembly (option) .....	2-28
2.25	Press Roller Assembly (No. 533100) .....	2-29
2.26	Upper Cover Assembly 533148 .....	2-31
2.27	Star Knob Assembly 533685 .....	2-32
2.28	Table Setting Handle (No. 533669) .....	2-33
2.29	Main Shaft Assembly 533682 .....	2-34
2.30	Helical Top Cutter Assembly - 564957 (Option) .....	2-35
2.31	Bearing Housing Assembly 533593 .....	2-36
2.32	Feed Assembly 533558 .....	2-37
2.33	Chain Tensioner 533583 .....	2-38
2.34	Drive Shaft Assembly (No. 533580) .....	2-39
2.35	Shaft w/Protective Cover (No. 533581) .....	2-40
2.36	Slide Bearing Assembly (No. 533520) .....	2-41
2.37	Up/Down Assembly 533115 .....	2-42
2.38	Chain Tensioner Assembly 533570 .....	2-43

## Table of Contents

## Section-Page

2.39	Table 546819 .....	2-44
2.40	Side Clamp, MP200/MP220 (No. 564986) - additional equipment .....	2-46

### SECTION 3 MOTOR KITS MP200 CE

3-1

3.1	PRO Motor Kit 533131 .....	3-2
3.2	ECO Motor Kit 533132 .....	3-4
3.3	Side Cutter Drive 533647 .....	3-6
3.4	Side Cutter Drive 533647-6 .....	3-7
3.5	Horizontal Cutter PRO Drive 533645-P .....	3-8
3.6	Horizontal Cutter ECO Drive 533645 .....	3-9
3.7	Horizontal Cutter Drive 533645-6 .....	3-10
3.8	ECO Feed Drive 533638 .....	3-11
3.9	Motoreducer 533639 .....	3-12
3.10	ECO Feed Drive 533638-6 .....	3-13
3.11	Motoreducer 533654 .....	3-14
3.12	PRO Feed Drive 533650 .....	3-15
3.13	Reducer 533640 .....	3-16
3.14	PRO Feed Drive 533650-6 .....	3-17
3.15	Motoreducer 532807 .....	3-18
3.16	Electric Box Mounting Bracket 533508 .....	3-19
3.17	Electrical Box 532820 .....	3-20

### SECTION 4 MOTOR KITS MP200 UL AMERICAN VERSION

4-1

4.1	PRO Motor Kit 533131-2U .....	4-2
4.2	PRO Motor Kit 533131-4U .....	4-3
4.3	PRO Motor Kit 533131-6U .....	4-4
4.4	ECO Motor Kit 533132-2U .....	4-6
4.5	ECO Motor Kit 533132-4U .....	4-8
4.6	ECO Motor Kit 533132-6U .....	4-10
4.7	Side Cutter Drive UL 533647-U .....	4-12
4.8	Side Cutter Drive 533647-6U .....	4-13
4.9	Horizontal Cutter PRO Drive 533645-PU .....	4-14
4.10	Horizontal Cutter Drive 533645-6U .....	4-15
4.11	Horizontal Cutter ECO Drive 533645-U .....	4-16
4.12	PRO Feed Drive 533650-U .....	4-17
4.13	Motoreducer 533640-UL .....	4-18
4.14	PRO Feed Drive 533650-6U .....	4-19
4.15	Up/Down Drive 597559 .....	4-20
4.16	ECO Feed Drive 533638-U .....	4-21
4.17	Motoreducer 533639-UL .....	4-22
4.18	ECO Feed Drive 533638-6U .....	4-23
4.19	Motoreducer 533654-UL .....	4-24

## SECTION 1 GENERAL INFORMATION

### 1.1 How To Use the Parts List

- Use the index above to locate the assembly that contains the part you need.
- Go to the appropriate section and locate the part in the illustration.
- Use the number pointing to the part to locate the correct part number and description in the table.
- Parts shown indented under another part are included with that part.
- Parts marked with a diamond (◆) are only available in the assembly listed above the part.

See the sample table below. Sample Part #A01111 includes part F02222-2 and subassembly A03333. Subassembly A03333 includes part S04444-4 and subassembly K05555. The diamond (◆) indicates that S04444-4 is not available except in subassembly A03333. Subassembly K05555 includes parts M06666 and F07777-77. The diamond (◆) indicates M06666 is not available except in subassembly K05555.

1.2 Sample Assembly				
REF.	DESCRIPTION (◆ Indicates Parts Available In Assemblies Only)	PART #	QTY	
	Sample Assembly, Complete (Includes All Indented Parts Below)	A01111	1	
1	Sample Part	F02222-22	1	
	Sample Subassembly (Includes All Indented Parts Below)	A03333	1	
2	Sample Part (◆ Indicates Part Is Only Available With A03333)	S04444-4	1	◆
	Sample Subassembly (Includes All Indented Parts Below)	K05555	1	
3	Sample Part (◆ Indicates Part Is Only Available With K05555)	M06666	2	◆
4	Sample Part	F07777-77	1	

#### To Order Parts:

- From Europe call our European Headquarters and Manufacturing Facility in Kolo, Poland at **+48-63-2626000**. From the continental U.S., call our toll-free Parts hotline at **1-800-525-8100**. Have your customer number, vehicle identification number, and part numbers ready when you call. From other international locations, contact the Wood-Mizer distributor in your area for parts.

#### Office Hours:

Country	Monday - Friday	Saturday	Sunday
Poland	7-15	Closed	Closed
US	8 a.m.- 5 p.m.	8 a.m.- 12 p.m.	Closed



**CAUTION!** It is strongly recommended that only original spare parts be used.

## SECTION 2 PLANER/MOULDER, MP200

### 2.1 Shafts

533120\_002  
 533120\_MANUAL

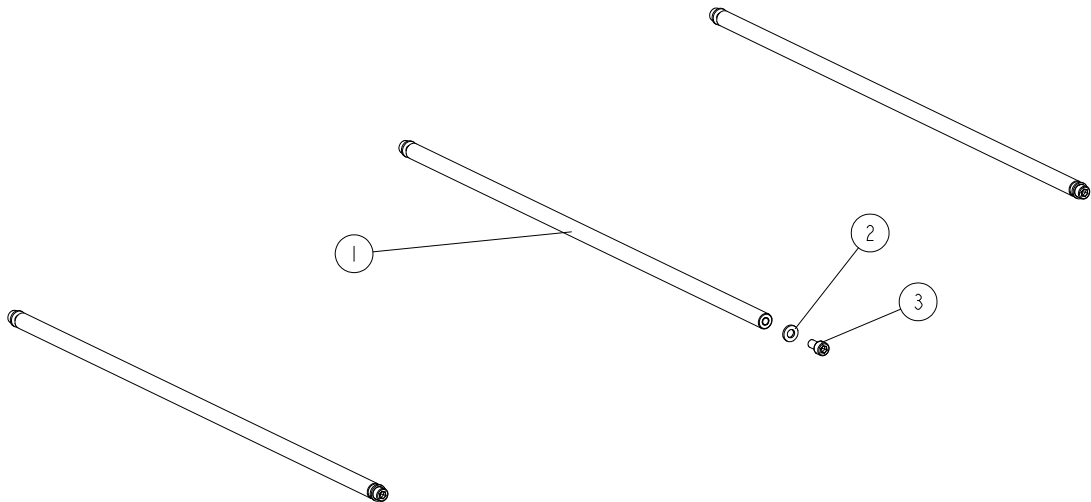
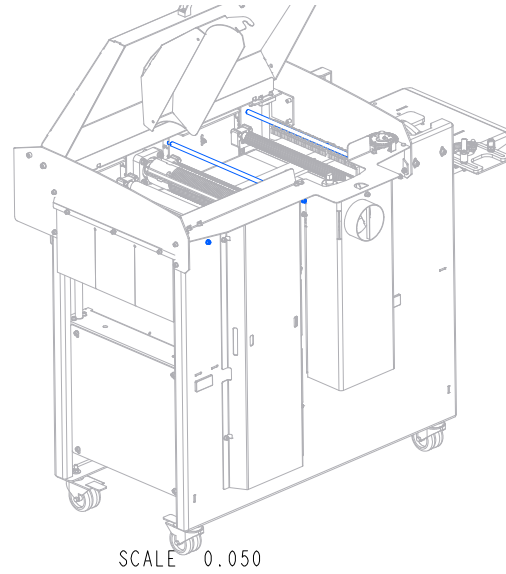

REF.	DESCRIPTION (* indicates parts available in assemblies only)	PART #	QTY
1	SHAFT	533092-1	3
2	WASHER, 6.4 FLAT ZINC	F81053-1	6
3	SCREW, ISO 4762-M6X12-8.8-A2E HEX SOCKET HEAD CAP	F81001-87	6

**2.2 Side Covers**

533120\_003  
533120\_MANUAL

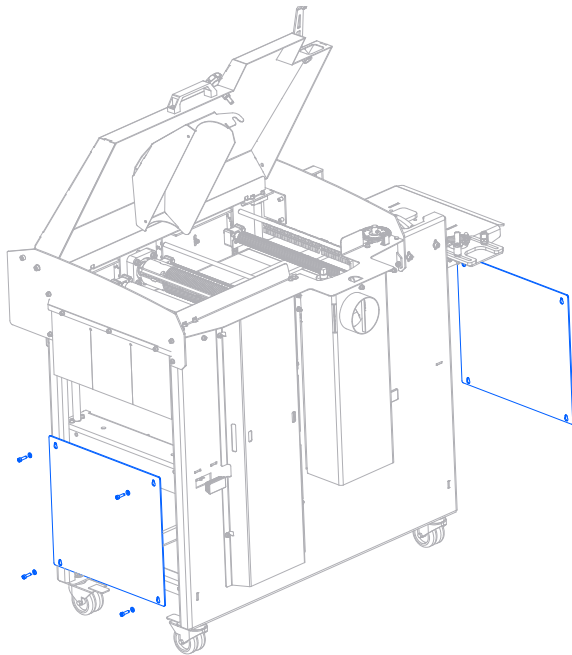

SCALE 0.050

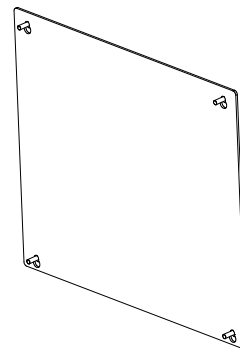
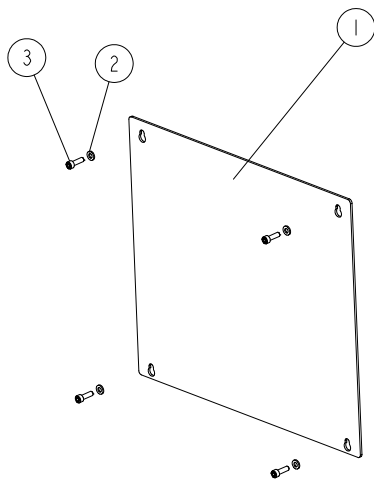

REF.	DESCRIPTION (* indicates parts available in assemblies only)	PART #	QTY
1	PLATE, SIDE	533096-1	2
2	WASHER, 6.4 FLAT ZINC	F81053-1	8
3	SCREW, M6X20 8.8 HEX SOCKET HEAD CAP ZINC	F81001-22	8

2.3 Front Cover

533120\_004  
 533120\_MANUAL

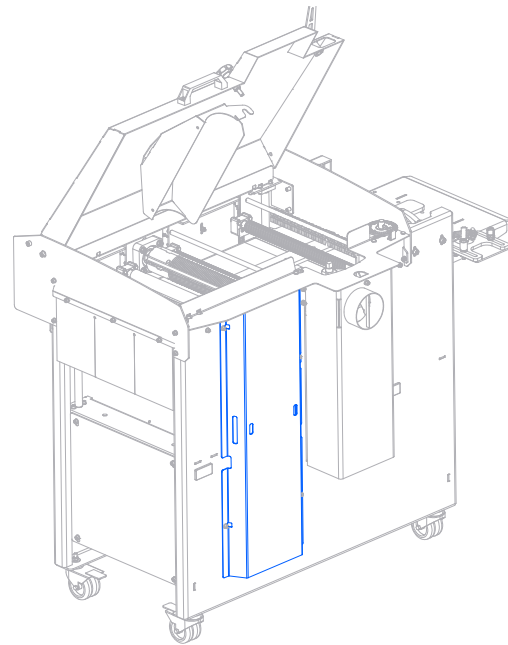
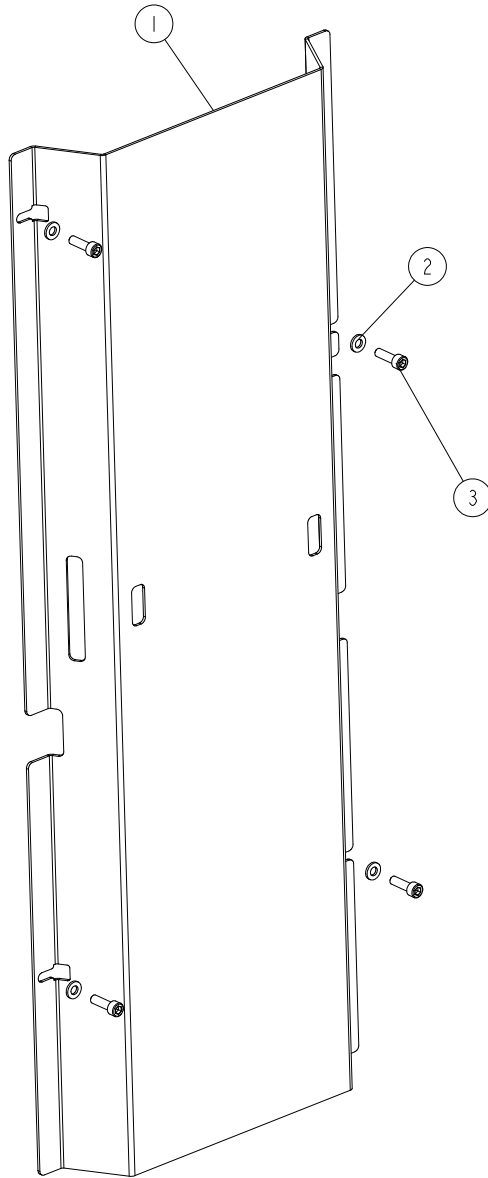

SCALE 0.050

REF.	DESCRIPTION (* indicates parts available in assemblies only)	PART #	QTY
1	COVER, FRONT	533104-1	1
2	WASHER, 6.4 FLAT ZINC	F81053-1	4
3	SCREW, M6X20 8.8 HEX SOCKET HEAD CAP ZINC	F81001-22	4

## 2.4 Insert & glide

533120\_006  
 533120\_MANUAL

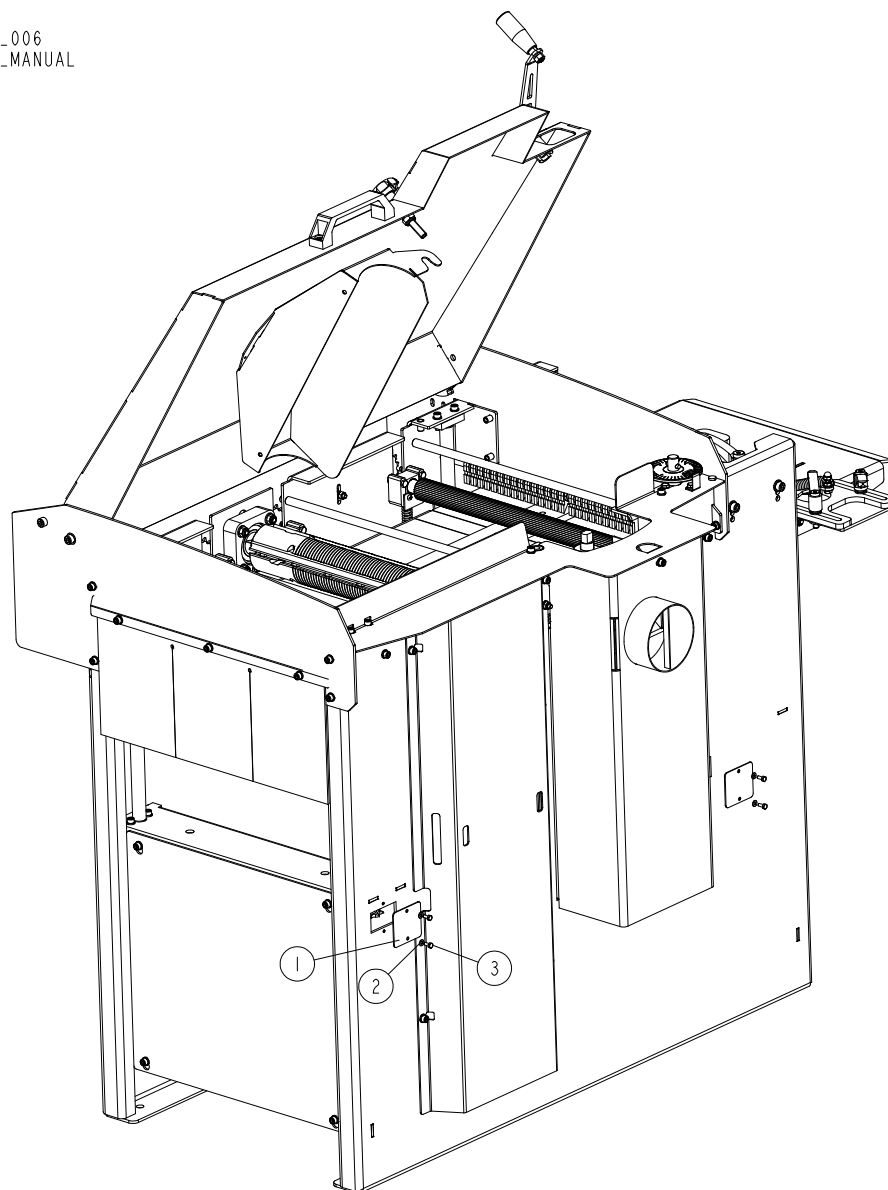

REF.	DESCRIPTION (* indicates parts available in assemblies only)	PART #	QTY
1	VISION COVER	536995-1	4
2	BUSH 4,3 FE/ZN5	F81051-2	8
2	SCREW M4x10 DIN933(A2)/ISO 4017 STAINLES	F81000-27	8



2.5 Decals

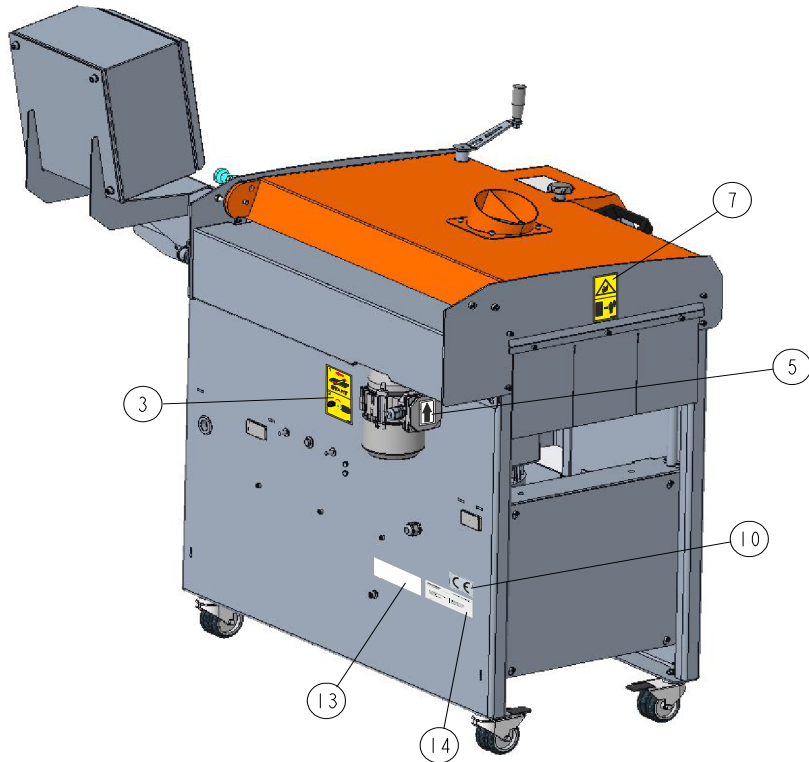
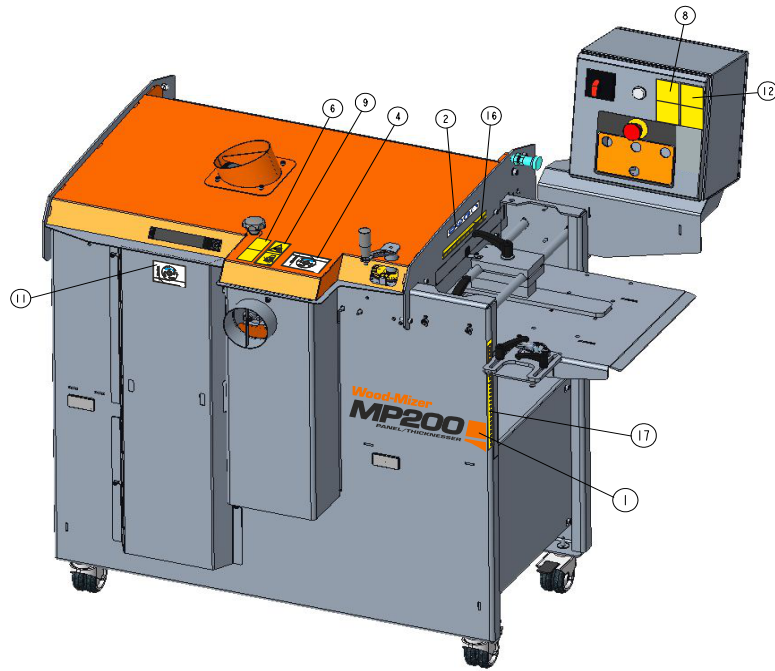

REF.	DESCRIPTION (* indicates parts available in assemblies only)	PART #	QTY
-	DECAL KIT, MP200	535151	1
1	DECAL, MP200 PLANER/MOULDER TYPE	535152	1
2	DECAL - WARNING PICTOGRAMS	535402	1

REF.	DESCRIPTION (* indicates parts available in assemblies only)	PART #	QTY
3	DECAL, "USE THE CONTINUOUSLY VARIABLE TRANSMISSION WHEN THE FEED IS TURNED ON" (PICTOGRAM)	535252	1
4	DECAL, MAXIMUM PLANING THICKNESS	535303	1
5	DECAL, MOTOR ROTATION DIRECTION	S20097	1
6	DECAL, "READ THE OPERATOR'S MANUAL"	096317	1
7	DECAL, "KEEP A SAFE DISTANCE" PICTOGRAM	099221V	1
8	DECAL, HAZARDOUS VOLTAGE INSIDE THE ELECTRIC BOX (PICTOGRAM)	096316	1
9	DECAL, "CLOSE GUARDS BEFORE OPERATING"	099220	1
10	DECAL, CE CERTIFIED SAWMILL - SMALL	P85070	1
11	DECAL, MAXIMUM CUTTING THICKNESS MP200	535155	1
12	DECAL, REMOVE THE PLUG BEFORE OPENING THE ELECTRIC BOX (PICTOGRAM)	096319	1
13	DECAL, VIN	VIN	1
14	DECAL, EUROPEAN HEADQUARTER ADDRESS	015841	1
15	DECAL, MP 200 ROUND SCALE	533577	1
16	DECAL, HORIZONTAL SCALE	533578	1
17	DECAL, VERTICAL SCALE	533579	1

## 2.6 MP200 Additional Part Kit

537668\_002\_EN  
 537668\_MANUAL

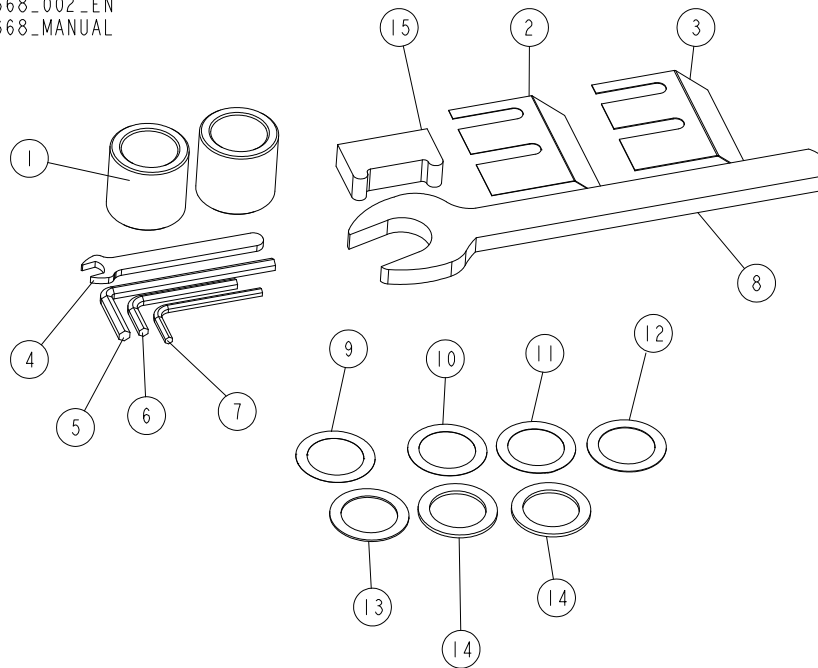

REF	DESCRIPTION (* indicates parts available in assemblies only)	PART #	QTY
-	<b>MP200 ADDITIONAL PART KIT</b>	537668	1
1	BUSHING 30/42-40.2 ZINC-PLATED	535848-1	2
2	PLATE, 0.3 MM CUTTER GUARD	537648	1
3	PLATE, 0.5 MM CUTTER GUARD	533502	1
-	<b>MP160 WRENCH KIT</b>	535185	1
4	WRENCH, 10 FLAT	541315	1
5	WRENCH, 6MM ALLEN	535186	1
6	WRENCH, 5 ALLEN	092915	1
7	WRENCH, 4MM ALLEN	093368	1
8	WRENCH 30 DIN 894	537649	1
9	WASHER 30/42-0.1 ZC DIN 988	F81069-6	1
10	WASHER 30/42-0.2 ZC DIN 988	F81069-5	1
11	WASHER 30/42-0.3 ZC DIN 988	F81069-4	1
12	WASHER 30/42-0.5 ZC DIN 988	F81069-3	1
13	WASHER 30/42-1 ZC DIN 988	F81069-2	1
14	WASHER 30/42-2 ZC DIN 988	F81069-1	2
15	KNIFE ALIGNMENT TOOL	534770	1

**2.7 MP200 Knives**

MP200\_011  
MP200EH6S\_MANUAL

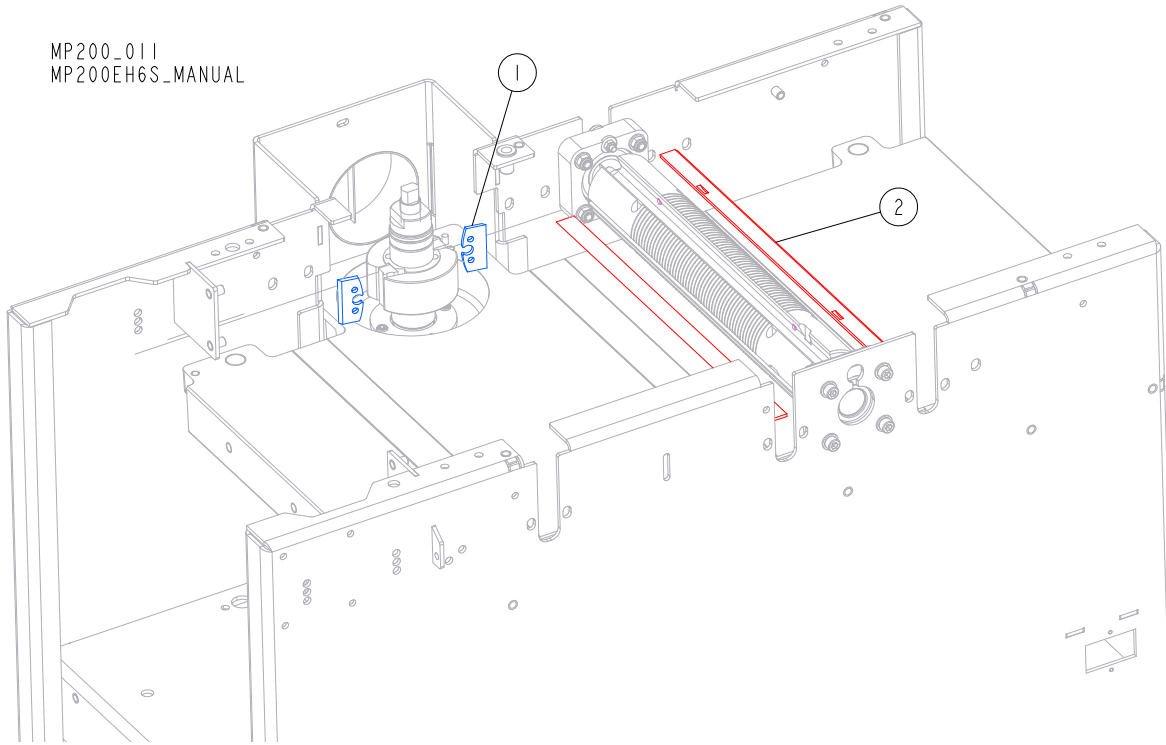

REF	DESCRIPTION (* indicates parts available in assemblies only)	PART #	QTY	
1	SIDE KNIFE, PLANER; HSS 50x24x4mm (2 PCS)	TPK50.024.4TB	1	
2	KNIFE, PLANER 410x20x3 W/NOTCH (1 PCS)	TPK410.20MP	2	

## 2.8 Foot Set (No. 536996)

536996\_001\_A  
536996

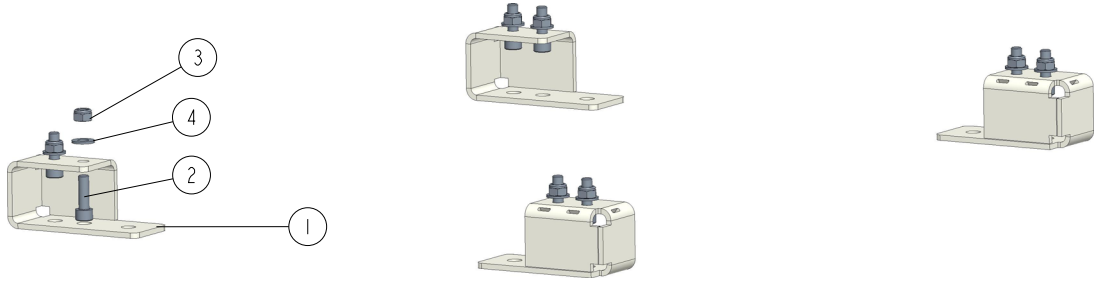

REF	DESCRIPTION (◆ indicates parts available in assemblies only)	PART #	QTY	
-	FOOT SET	536996	1	
1	FOOT	535828-1	4	
2	SCREW, M8X25 -8.8 HEX SOCKET HEAD CAP	F81002-21	8	
3	NUT, M8-8-B HEX NYLON ZINC LOCK	F81032-2	8	
4	WASHER, 8.4 FLAT ZINC	F81054-1	16	

## 2.9 Front Plate 533127

533127\_001  
533127\_MANUAL

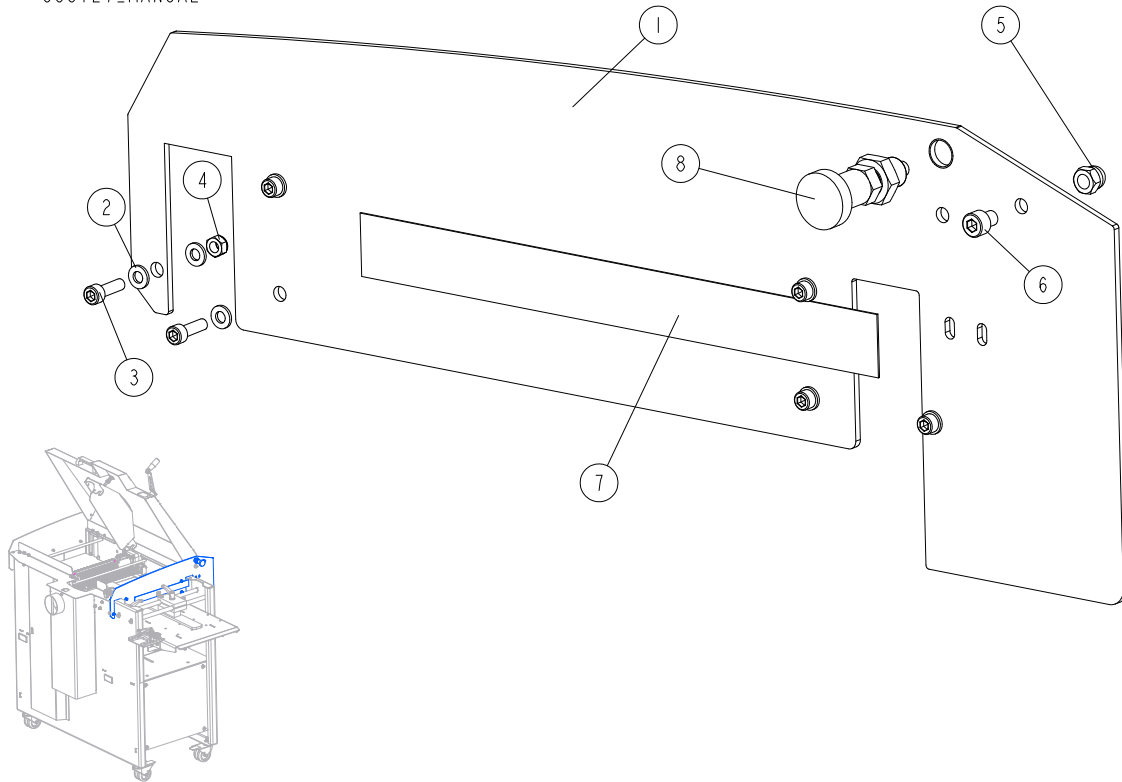

REF.	DESCRIPTION (* indicates parts available in assemblies only)	PART #	QTY
-	<b>PLATE, FRONT COMPLETE</b>	533127	1
1	COVER, RIGHT	533094-1	1
2	WASHER, 6.4 FLAT ZINC	F81053-1	8
3	SCREW, M6X20 8.8 HEX SOCKET HEAD CAP ZINC	F81001-22	6
4	NUT, M6-8-B HEX NYLON ZINC LOCK	F81031-2	2
5	NUT, M8 DOMED CAP	F81033-25	1
6	SCREW, M8X10-8.8 HEX SOCKET HEAD CAP ZINC	F81002-32	1
7	DECAL, HORIZONTAL SCALE	533578	1
8	PIN, 45308DNW DETENT	089939	1

## 2.10 Castor wheels 535166

535166\_001  
535166\_MANUAL

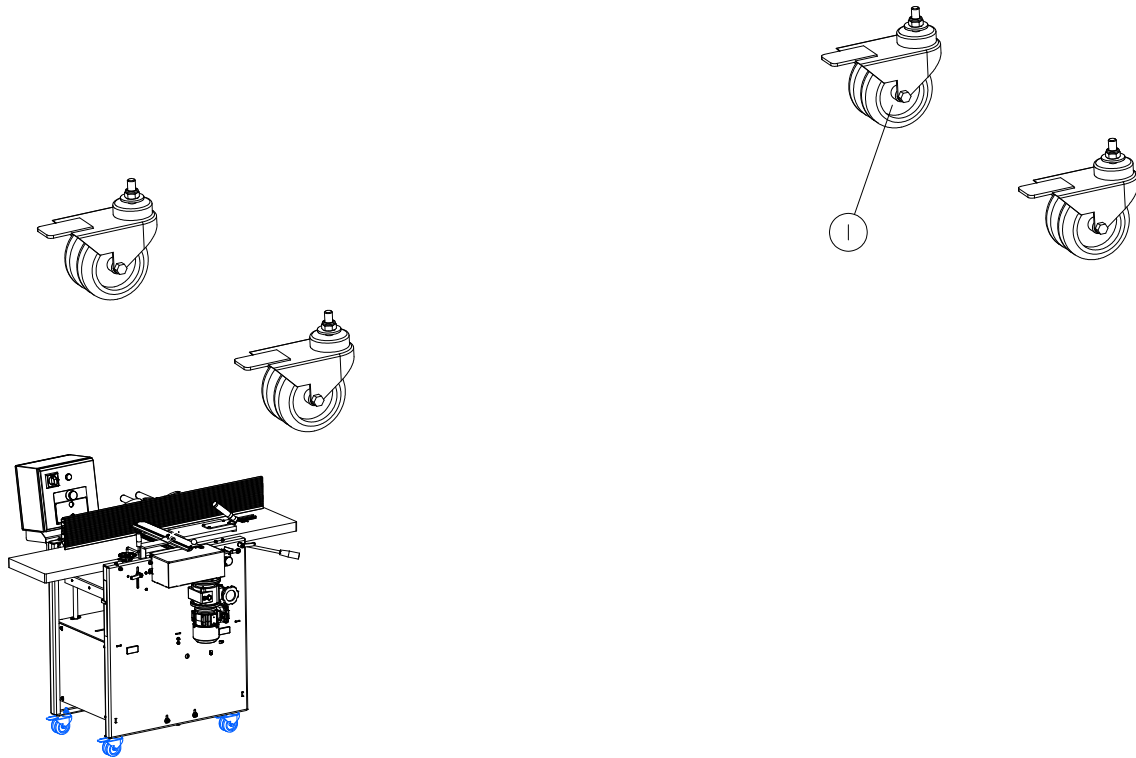

REF.	DESCRIPTION (* indicates parts available in assemblies only)	PART #	QTY	
-	CASTOR WHEELS, 4 PCS. KIT	535166	1	
1	CASTOR WHEEL ASSEMBLY <a href="#">See Section 2.11</a>	535163	4	

**2.11 Castor wheel assembly 535163**

535163\_001  
535163\_MANUAL

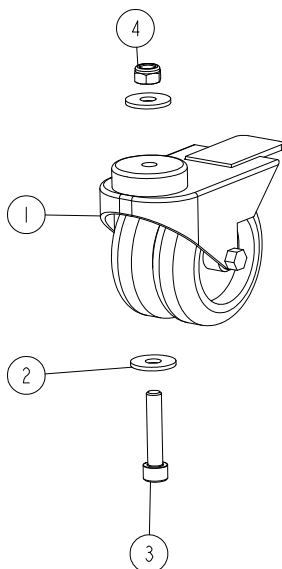

REF.	DESCRIPTION (* indicates parts available in assemblies only)	PART #	QTY
-	<b>CASTOR WHEEL ASSEMBLY</b>	535163	1
1	DUAL WHEEL CASTOR, KMDA-TPA 75S-HC	533510	1
2	WASHER, ISO 7093-1-8-200 HV-A2E.	F81054-11	2
3	SCREW, M8X40-8.8 HEX SOCKET HEAD CAP ZINC	F81002-29	1
4	NUT, M8-8-B HEX NYLON ZINC LOCK	F81032-2	1



## 2.12 Left Cover 533130

533130\_001  
533130\_MANUAL

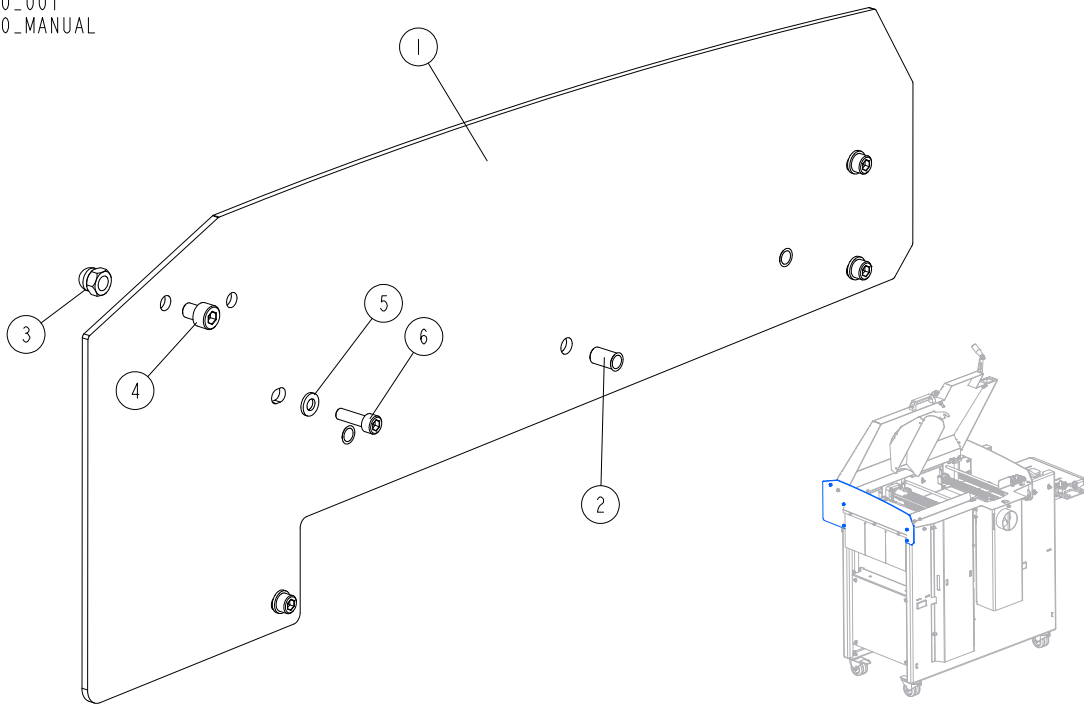

REF.	DESCRIPTION (* indicates parts available in assemblies only)	PART #	QTY	
-	<b>COVER, LEFT COMPLETE</b>	533130	1	
1	COVER, LEFT	533093-1	1	
2	NUT, O-NIT-6-17-ZN RIVET	F81031-13	3	
3	NUT, M8 DOMED CAP	F81033-25	1	
4	SCREW, M8X10-8.8 HEX SOCKET HEAD CAP ZINC	F81002-32	1	
5	WASHER, 6.4 FLAT ZINC	F81053-1	4	
6	SCREW, M6X20 8.8 HEX SOCKET HEAD CAP ZINC	F81001-22	4	

**2.13 Anti-kickback Fingers Assembly 533125**

533125\_001\_B  
533125\_MANUAL

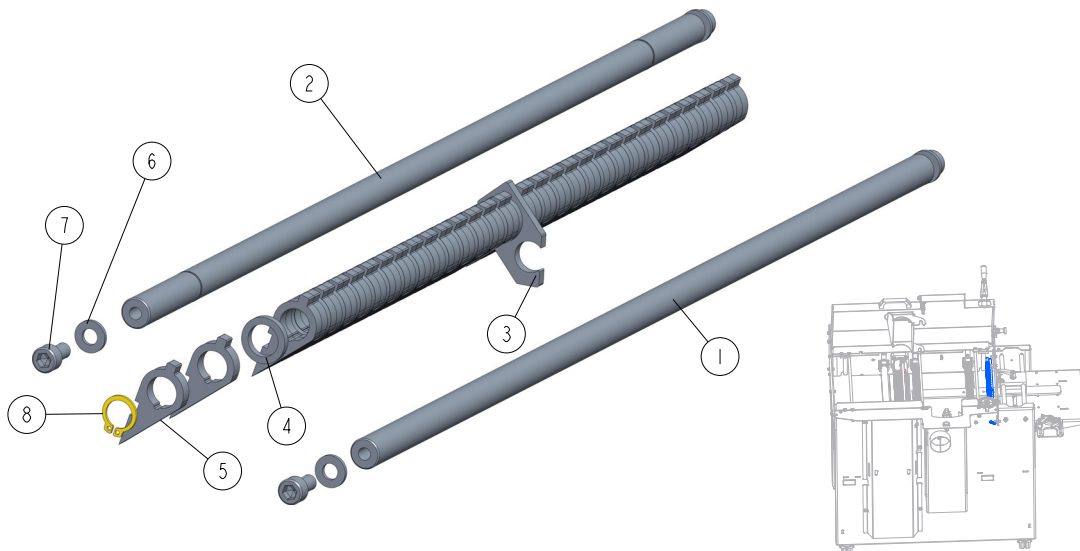

REF	DESCRIPTION (u indicates parts available in assemblies only)	PART #	QTY
-	<b>ANTI-KICKBACK FINGERS ASSEMBLY</b>	533125	1
1	SHAFT	533092-1	1
2	ROD, ANTI-KICKBACK FINGER	546931-1	1
3	PLATE	533124-1	1
4	WASHER, DIA.1940	533123	30
5	ANTI-KICKBACK FINGER	533126	30
6	WASHER, 6.4 FLAT ZINC	F81053-1	4
7	SCREW M6X12 SHCS ZC 8.8 DIN 912 ISO 4762	F81001-87	4
8	RING RETAINING OR Z12 PN-81/M-85111 DIN	F81090-14	2

## 2.14 Fence Assembly 533535

533535\_001  
533535\_MANUAL

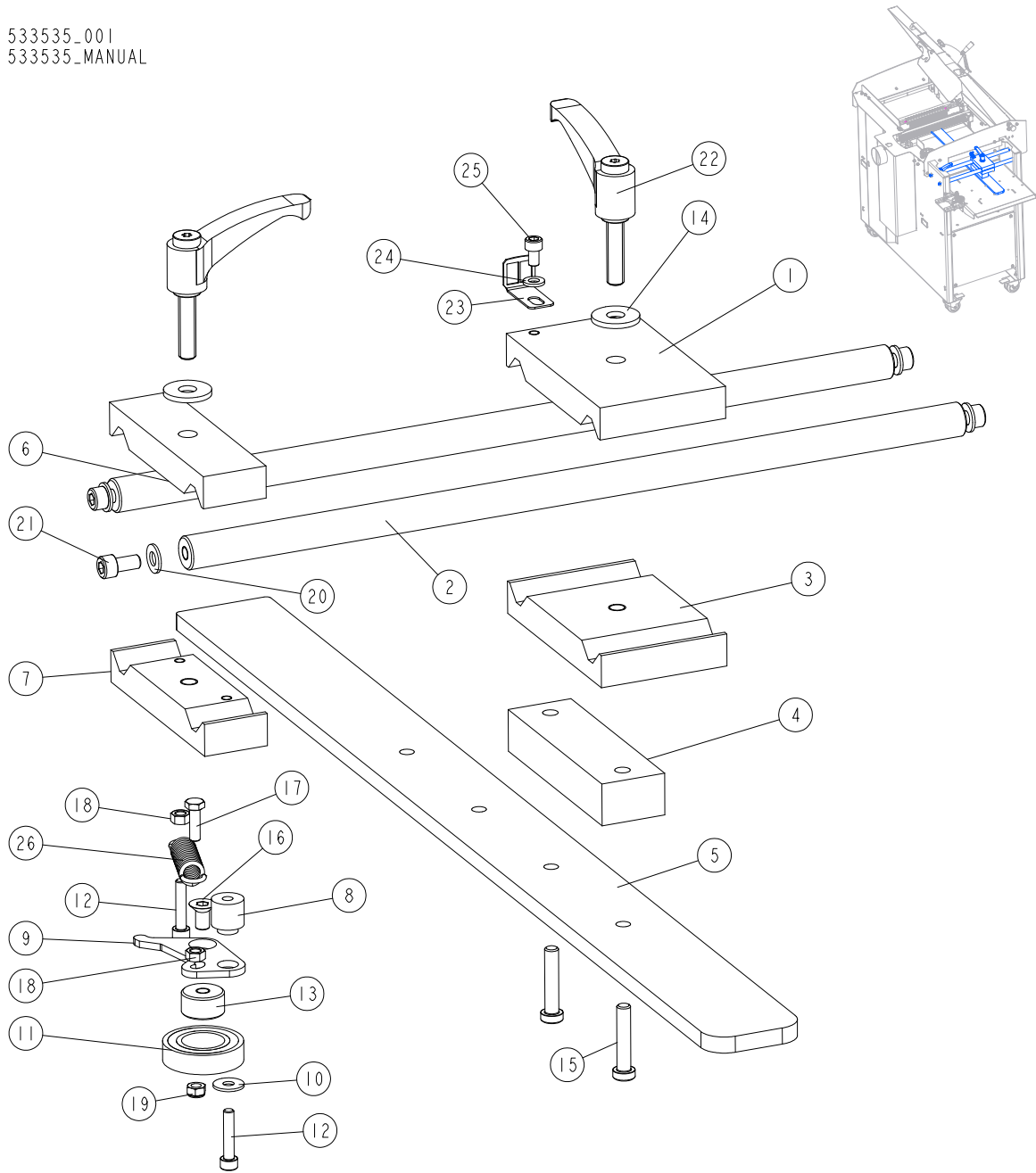

REF.	DESCRIPTION (* indicates parts available in assemblies only)	PART #	QTY
-	<b>FENCE ASSEMBLY</b>	533535	1
1	BRACKET, FENCE ROD UPPER	533530-1	1
2	ROD, N20X494	533531-1	2
3	BRACKET, FENCE ROD LOWER	533523-1	1
4	PLATE, 26X40X130 CONNECTION	533522-1	1
5	BAR, FENCE	533524-1	1
6	PLATE, BASIC UPPER	533527-1	1
7	PLATE, BASIC LOWER	533526-1	1
8	BUSHING, 6.2/19-20.3	533528	1

REF.	DESCRIPTION (* indicates parts available in assemblies only)	PART #	QTY	
9	BRACKET, BEARING MOVABLE	533525-1	1	
10	WASHER, 6.5 ZINC SPECIAL FLAT	F81053-11	1	
11	BEARING, 6005 2RS	089652	1	
12	SCREW, M6X30-8.8 HEX SOCKET HEAD CAP ZINC	F81001-42	2	
13	BUSHING, M8/25-13.5 ZINC-PLATED	533529-1	1	
14	WASHER, 10.5 SPECIAL FLAT ZINC	F81055-6	2	
15	BOLT, M8X40-8.8.FE/ZN5 7984 CLASS 8.8	F81002-81	2	
16	SCREW, M8X16 FE/ZN5 7991 10.9 FLAT SOCKET HEAD CAP	F81002-82	1	
17	BOLT, M6X20 8.8 HEX HEAD FULL THREAD ZINC	F81001-2	1	
18	NUT, M6 8 HEX ZINC	F81031-1	2	
19	NUT, M6-8-B HEX NYLON ZINC LOCK	F81031-2	1	
20	WASHER, 8.4 FLAT ZINC	F81054-1	4	
21	SCREW, M8X16-8.8 HEX SOCKET HEAD CAP ZINC	F81002-39	4	
22	HANDLE, ERZ.78 P-M10X40 ADJUSTABLE	533536	2	
23	INDICATOR, SCALE	533098	1	
24	WASHER, 6.4 FLAT ZINC	F81053-1	1	
25	SCREW, M6X10 8.8 HEX SOCKET HEAD CAP ZINC	F81001-12	1	
26	SPRING, 15X65X2.5	533571	1	

## 2.15 Fence Assembly - Optional (564884)

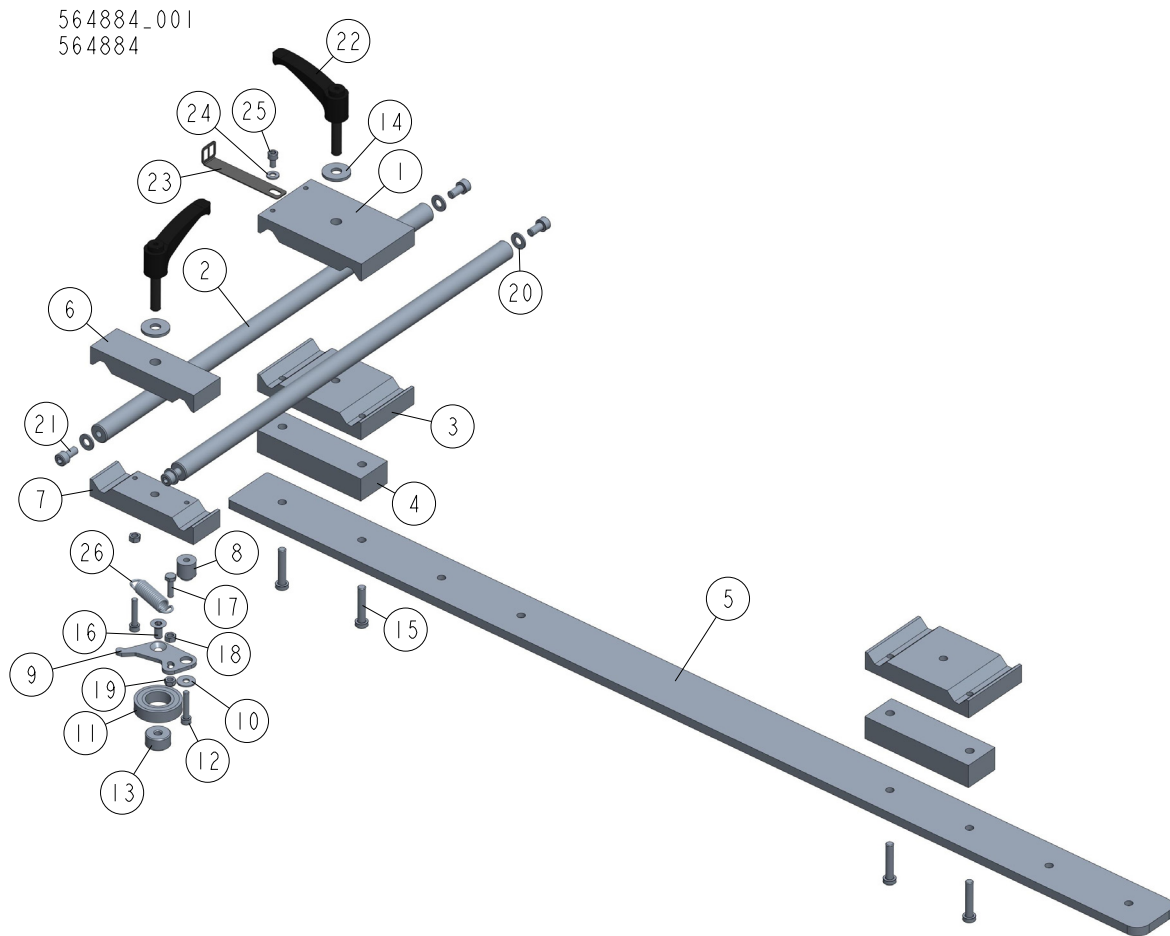

REF	DESCRIPTION (◆ indicates parts available in assemblies only)	PART #	QTY
-	<b>FENCE ASSEMBLY (OPTIONAL)</b>	564884	1
1	BRACKET, ROD MOUNT - UPPER	533530-1	1
2	ROD, N20X494	533531-1	2
3	BRACKET, ROD MOUNT - LOWER	533523-1	2
4	BLOCK, 26X40X130 CONNECTION	533522-1	2
5	RAIL, GUIDE	564885-1	1
6	PLATE, BASIC UPPER	533527-1	1
7	PLATE, BASIC LOWER	533526-1	1
8	BUSHING, 6.2/19-20.3 12-4.3	533528	1
9	BRACKET, BEARING MOVABLE	533525-1	1
10	WASHER, 6.5 SPECIAL FLAT ZINC	F81053-11	1
11	BEARING, 6005 2RS PN-85/M-86100	089652	1
12	SCREW, M6X30-8.8 HEX SOCKET HEAD CAP ZIN	F81001-42	2
13	BUSHING, M8/25-13.5 ZINC-PLATED	533529-1	1
14	WASHER 10,5 ZC FENDER DIN 9021 ISO 7093	F81055-6	2
15	SCREW, M8X40-8.8-FE/ZN5 DIN 7984 ISO 145	F81002-81	4
16	SCREW, M8X16-10.9 FE/ZN5 DIN7991 FLAT SO	F81002-82	1
17	BOLT, M6X20 8.8 HEX HEAD FULL THREAD ZIN	F81001-2	1
18	NUT, M6-8 HEX ZINC	F81031-1	2

REF	DESCRIPTION (◆ indicates parts available in assemblies only)	PART #	QTY	
19	NUT, M6-8-B HEX NYLON ZINC LOCK	F81031-2	1	
20	WASHER, 8,4-FLAT ZINC	F81054-1	4	
21	SCREW, M8X16-8.8 HEX SOCKET HEAD CAP ZIN	F81002-39	4	
22	HANDLE, ERZ.78 P-M10X40 ADJUSTABLE	533536	2	
23	INDICATOR, SCALE	564888	1	
24	WASHER, 6.4 FLAT ZINC	F81053-1	1	
25	SCREW, M6X10 8.8 HEX SOCKET HEAD CAP ZIN	F81001-12	1	
26	SPRING, 15X65X2.5 EXTENSION	533571	1	

### 2.16 Table, MP200 533545

533545\_001  
533545\_MANUAL

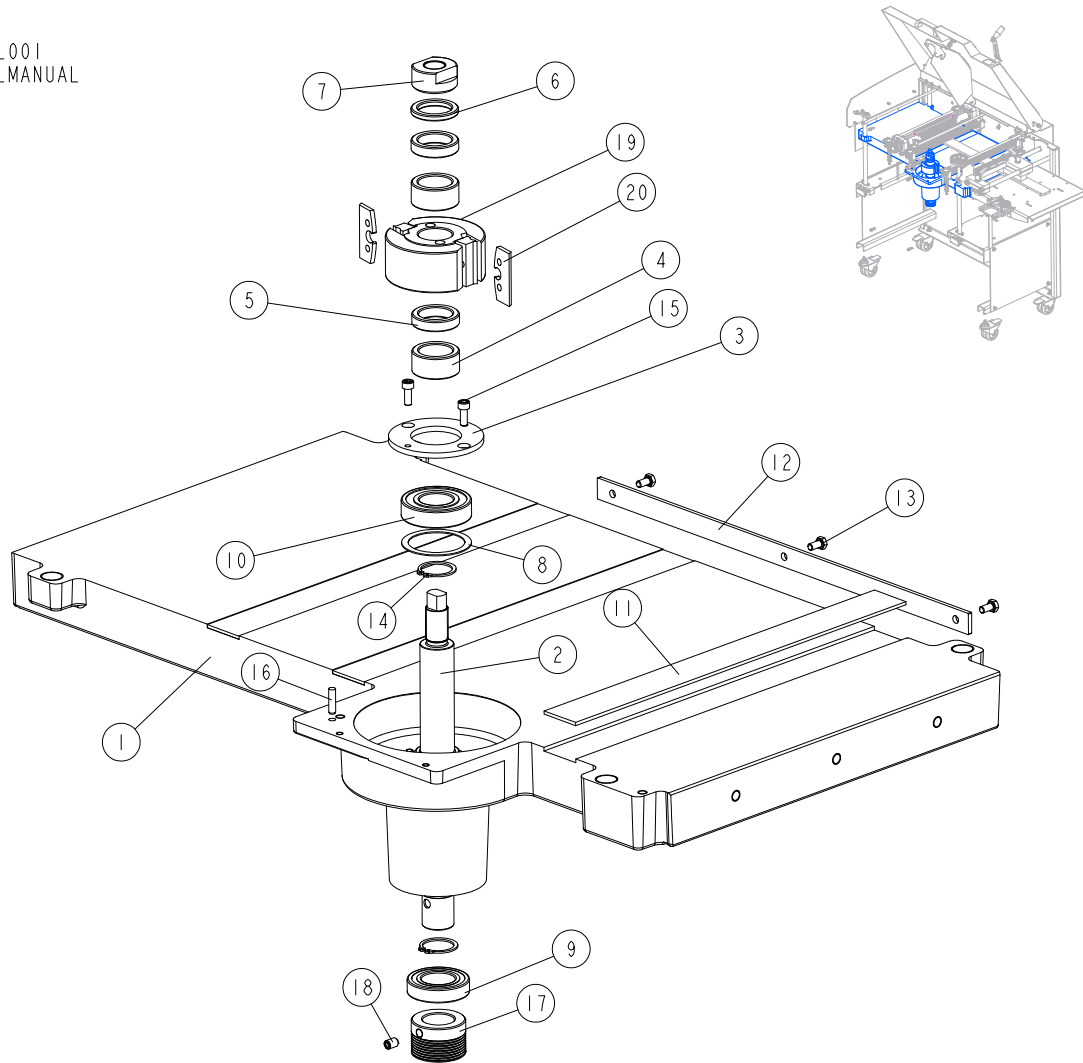

REF.	DESCRIPTION (* indicates parts available in assemblies only)	PART #	QTY
-	<b>TABLE, MP200 COMPLETE</b>	533545	1
1	TABLE, MP200	546834-1	1
2	SHAFT	533537	1
3	PLATE, CLAMPING	533542-1	1
4	BUSHING, 30/42-20.2 ZINC-PLATED	533541-1	2
5	BUSHING, 30/42-10 ZINC-PLATED	533539-1	2
6	BUSHING, 30/42-5.2 ZINC-PLATED	533540-1	1
7	NUT, M20X1.5	533538-1	1
8	WASHER, 50X61.6X1	533543	1
9	BEARING, 6006-C-2HRS-FAG	592792	1
10	BEARING, 6206-C-2HRS-FAG	592793	1
11	PLATE, SLIDE	533544	3
12	BAR	533546-1	1
13	BOLT, M6X12 8.8 HEX HEAD FULL THREAD ZINC	F81001-7	3
14	RING, 30Z OUTSIDE RETAINING	F81090-23	2
15	SCREW, M6X16 8.8 HEX SOCKET HEAD CAP ZINC	F81001-21	2

REF.	DESCRIPTION (* indicates parts available in assemblies only)	PART #	QTY	
16	PIN, ISO2338-6M6X24-A1 PARALLEL	F81045-5	1	
17	PULLEY, MULTI-GROOVE SMALL ALUMINIUM	533586	1	
18	SCREW, M8X12-45H FE/ZN DIN914 HEX SOCKET SET W/CONE POINT	F81002-105	1	
-	PROFILE HEAD 93X40X30 Z=2	TG56.2K	1	
19	CUTTER, UNIVERSAL	533587	1	
20	SIDE KNIFE, PLANER; HSS 50x24x4mm (2 PCS)	TPK50.024.4TB	1	
	KIT, ADJUSTMENT SHIMS	561712-S	1	
	SHIM, 30/42-2 FE/ZN5 DIN 988	F81069-1	2	
	SHIM, 30/42-1 FE/ZN5 DIN 988	F81069-2	2	
	SHIM, 30/42-0.5 FE/ZN5 DIN 988	F81069-3	2	
	SHIM, 30/42-0.3 FE/ZN5 DIN 988	F81069-4	2	
	SHIM, 30/42-0.2 FE/ZN5 DIN 988	F81069-5	2	
	SHIM, 30/42-0.1 FE/ZN5 DIN 988	F81069-6	2	



## 2.17 Press Roller Assembly 533550

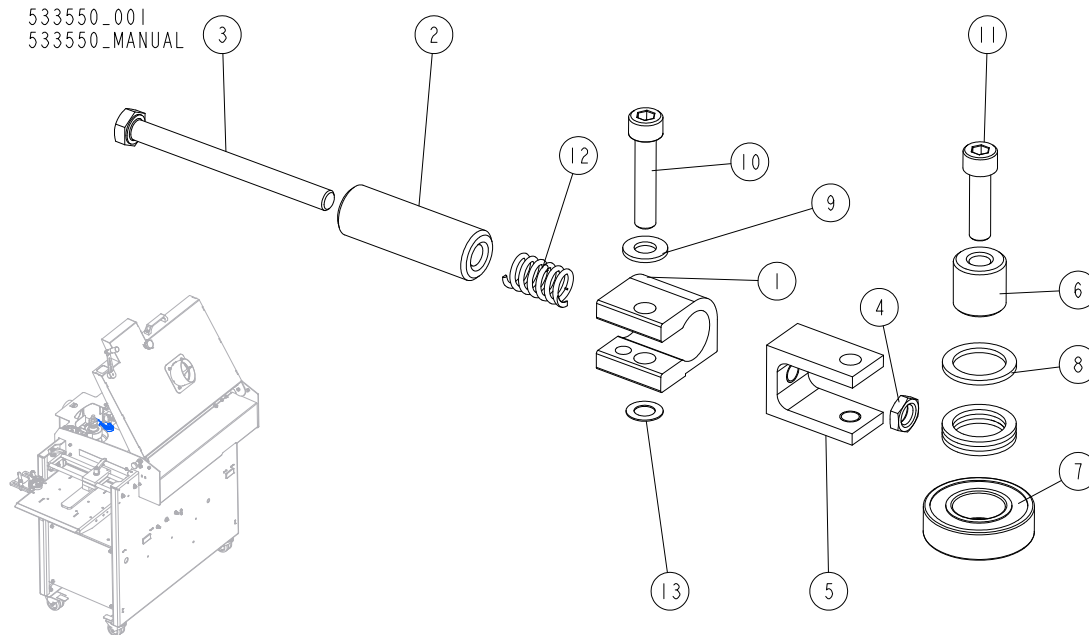

REF.	DESCRIPTION (* indicates parts available in assemblies only)	PART #	QTY
-	<b>PRESS ROLLER ASSEMBLY II</b>	533550	1
1	CONNECTOR, ALUMINIUM	533551-1	1
2	BUSHING, 8.5/20-60 ZINC-PLATED	533553-1	1
3	BOLT, M8X90-8.8 HEX HEAD FULL THREAD ZINC	F81002-16	1
4	NUT, M8-04-HEX THIN ZINC	F81032-8	1
5	CONNECTOR, ALUMINIUM	533552	1
6	BUSHING, 8.2/20-20	533554-1	1
7	BEARING, 6004 2RS CX ROLLING	093868	1
8	WASHER, 28/20-2	533555	4
9	WASHER, 8.4 FLAT ZINC	F81054-1	1
10	SCREW, M8X40-8.8 HEX SOCKET HEAD CAP ZINC	F81002-29	1
11	SCREW, M8X30-8.8 HEX SOCKET HEAD CAP ZINC	F81002-31	1
12	SPRING, 12X25XN2	533556	1
13	WASHER, 14 DIN 988 SPACER ZINC	F81055-16	1

**2.18 Cutter Guard Assembly 533507**

533507\_001  
533507\_MANUAL

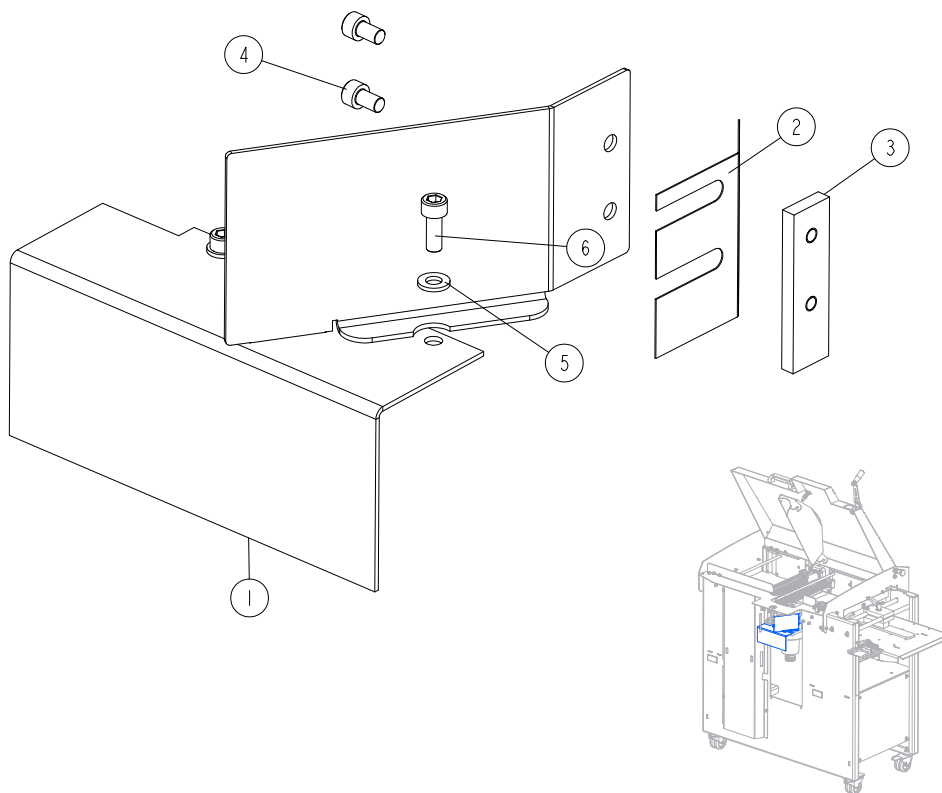

REF.	DESCRIPTION (* indicates parts available in assemblies only)	PART #	QTY	
-	<b>GUARD ASSEMBLY, CUTTER</b>	533507	1	
1	GUARD, CUTTER	533501-1	1	
2	PLATE, 0.5 MM CUTTER GUARD	533502	1	
3	PLATE, CUTTER GUARD CLAMPING	533503-1	1	
4	SCREW, M6X10 8.8 HEX SOCKET HEAD CAP ZINC	F81001-12	2	
5	WASHER, 6.4 FLAT ZINC	F81053-1	2	
6	SCREW, M6X16 8.8 HEX SOCKET HEAD CAP ZINC	F81001-21	2	

## 2.19 Upper Guard 533567

533567\_001\_A  
533567\_MANUAL

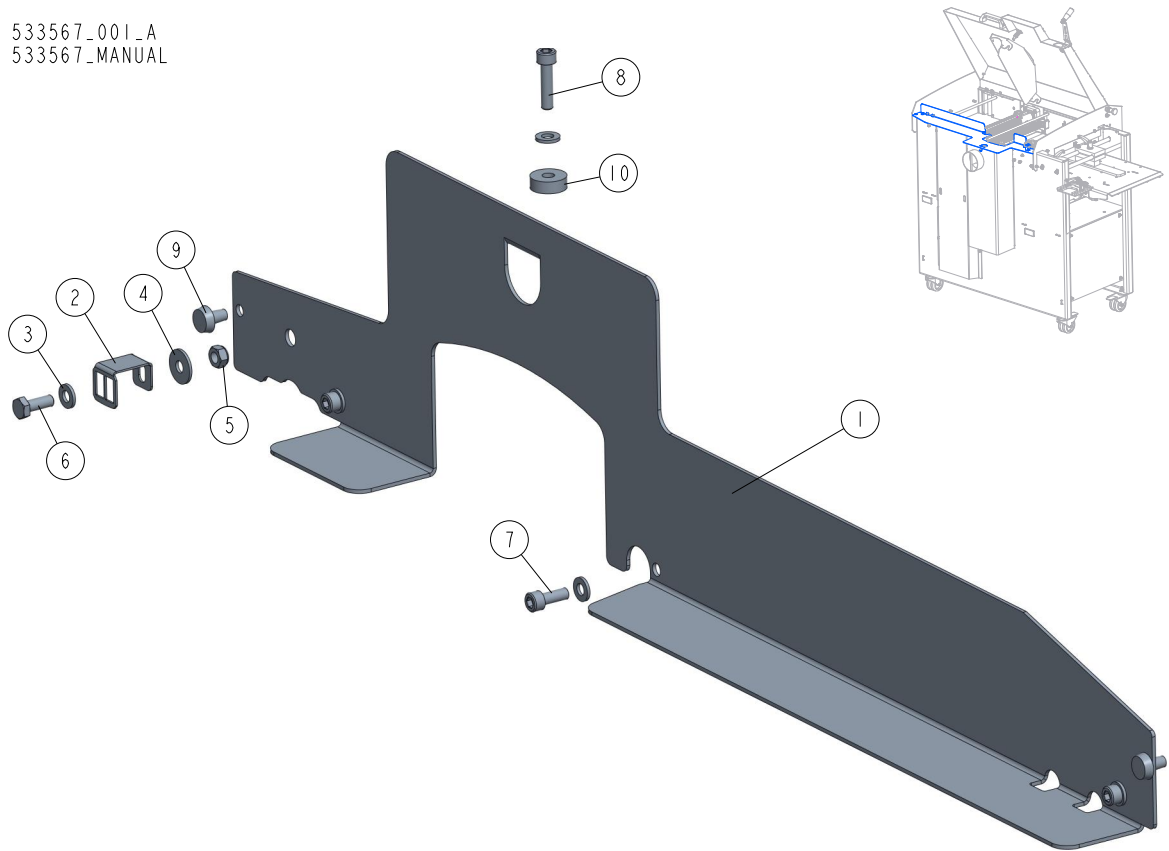

REF	DESCRIPTION (◆ indicates parts available in assemblies only)	PART #	QTY
-	<b>GUARD, UPPER COMPLETE</b>	533567	1
1	COVER, TOP	533657-1	1
2	INDICATOR, SCALE	533097	1
3	WASHER, 6.4 FLAT ZINC	F81053-1	5
4	WASHER, 6.5 SPECIAL FLAT ZINC	F81053-11	2
5	NUT, M6-8-B HEX NYLON ZINC LOCK	F81031-2	2
6	BOLT, M6X16-8.8 HEX HEAD FULL THREAD ZIN	F81001-15	1
7	SCREW, M6X16 -8.8 HEX SOCKET HEAD CAP ZI	F81001-21	3
8	BOLT M6X25 SHCS ZC PT 8.8 DIN 912 ISO 47	F81001-41	1
9	FEET, SRI591 12X6 GROMMET	101279	2
10	BUSHING, SPACER. PA 6.4/18.8-6.4	561841	1

## 2.20 Round Scale (No. 533676)

533676\_001\_A  
533676\_MANUAL

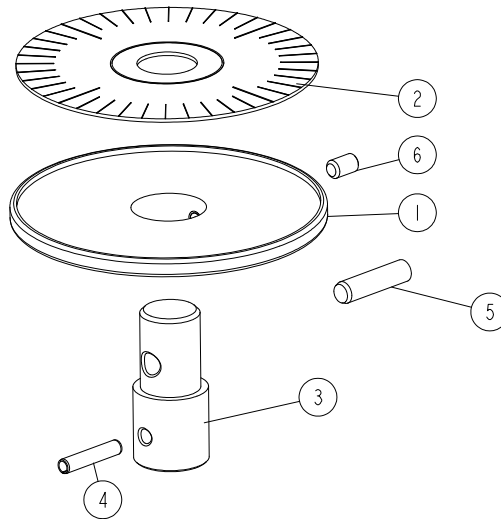

REF.	DESCRIPTION (* indicates parts available in assemblies only)	PART #	QTY	
-	<b>SCALE, COMPLETE ROUND</b>	533676	1	
1	DISK, ROUND SCALE	533594	1	
2	DECAL, MP200 ROUND SCALE	533577	1	
3	PIN, SCALE DISK MOUNT	533595-1	1	
4	PIN, PN-EN ISO 8752-4X20-ST-A0P SPRING-TYPE	F81044-11	1	
5	PIN, ISO2338- 6M6X24-A1 DOWEL	F81045-5	1	
6	SCREW, M5X8 45H DIN 913 HEX SOCKET SET W/FLAT POINT	F81014-7	1	

## 2.21 Flexible Guard (533729)

533729\_001\_A  
533729\_MANUAL

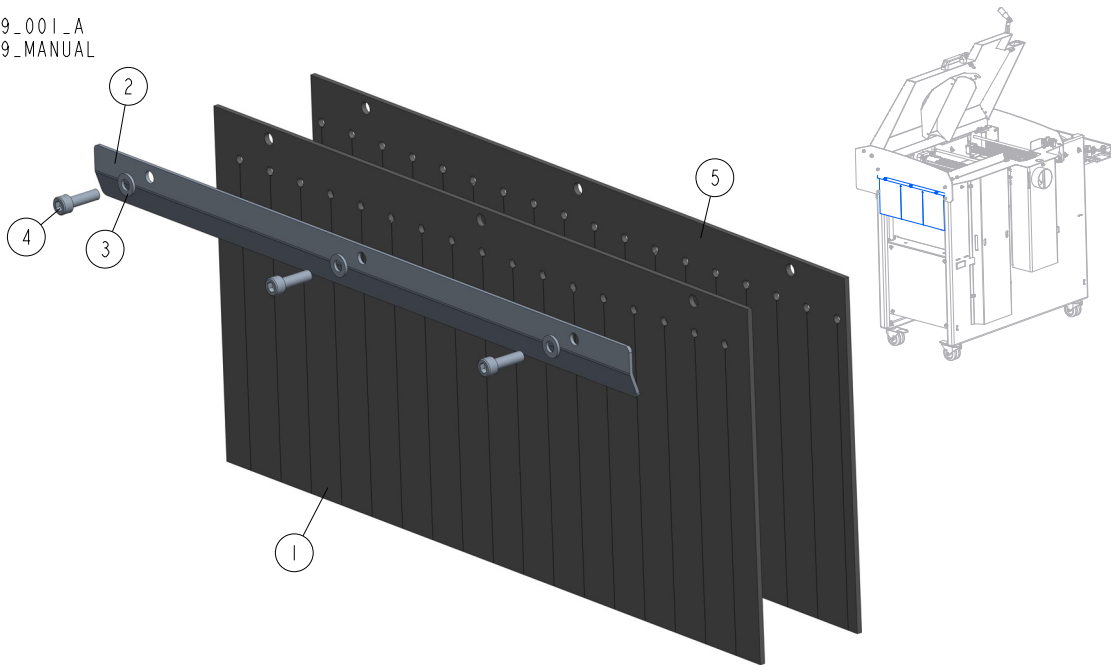

REF	DESCRIPTION (u indicates parts available in assemblies only)	PART #	QTY	
-	<b>GUARD, COMPLETE FLEXIBLE</b>	533729	1	
1	GUARD, FLEXIBLE	533083	1	
2	BRACKET, FLEXIBLE GUARD	537551-1	1	
3	WASHER, 6.4 FLAT ZINC	F81053-1	3	
4	SCREW, M6X20 8.8 HEX SOCKET HEAD CAP ZIN	F81001-22	3	
5	GUARD, FLEXIBLE	564886	1	

## 2.22 Infeed Table 533095

533095\_001\_A  
533095\_MANUAL

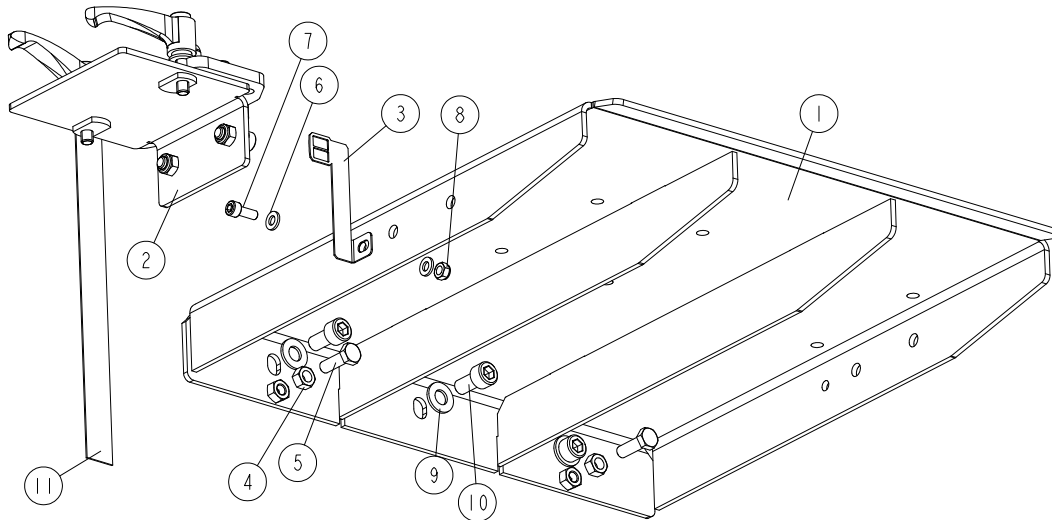

REF.	DESCRIPTION (* indicates parts available in assemblies only)	PART #	QTY
-	<b>TABLE, INFEED - COMPLETE</b>	533095	1
1	TABLE, INFEED WLDMT/PTD	533665-1	1
2	PRESS ROLLER ASSEMBLY <a href="#">See Section 2.21</a>	533100	1
3	POINTER, SCALE	564883	1
4	NUT, M8-8-B HEX ZINC	F81032-1	2
5	BOLT, M8X25-8.8-B HEX HEAD FULL THREAD ZINC	F81002-5	2
6	WASHER, 6.4 FLAT ZINC	F81053-1	2
7	SCREW, ISO 4762-M6X16-8.8-A2E HEX SOCKET HEAD CAP	F81001-34	1
8	NUT, M6-8-B HEX NYLON ZINC LOCK	F81031-2	1
9	WASHER, 10.5 FLAT ZINC	F81055-1	3
10	SCREW, M10X20 8.8 HEX SOCKET HEAD CAP ZINC	F81003-108	3
11	DECAL, VERTICAL SCALE	533579	1

2.23 Outfeed Table Extension (No. 546935)

546935\_001  
546935\_MANUAL

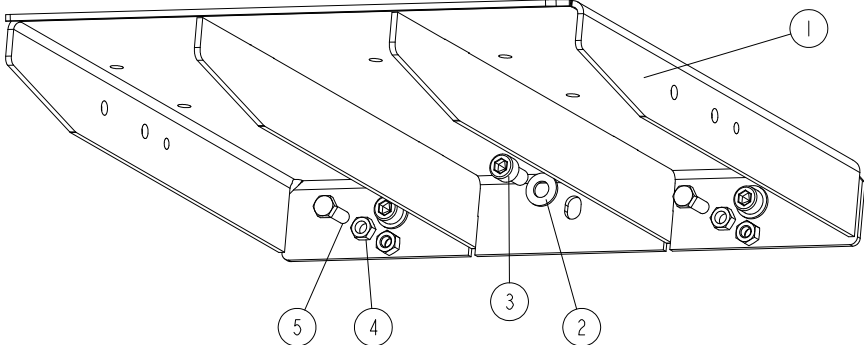

REF	DESCRIPTION (◆ indicates parts available in assemblies only)	PART #	QTY	
-	EXTENSION, OUTFEED TABLE	546935	1	
1	TABLE, INFEED WLDMT/PTD	533665-1	1	
2	WASHER, 10.5 FLAT ZINC	F81055-1	3	
3	SCREW M10X20 SHCS ZC 8.8 DIN 912 ISO4762	F81003-108	3	
4	NUT, M8 HEXAGON, GRADE 5.8 FREE ZINC	F81032-1	2	
5	BOLT, M8X25-8.8-B HEX HEAD FULL THREAD ZI	F81002-5	2	

## 2.24 Material Guide Assembly (option)

554101\_001  
554101\_MANUAL

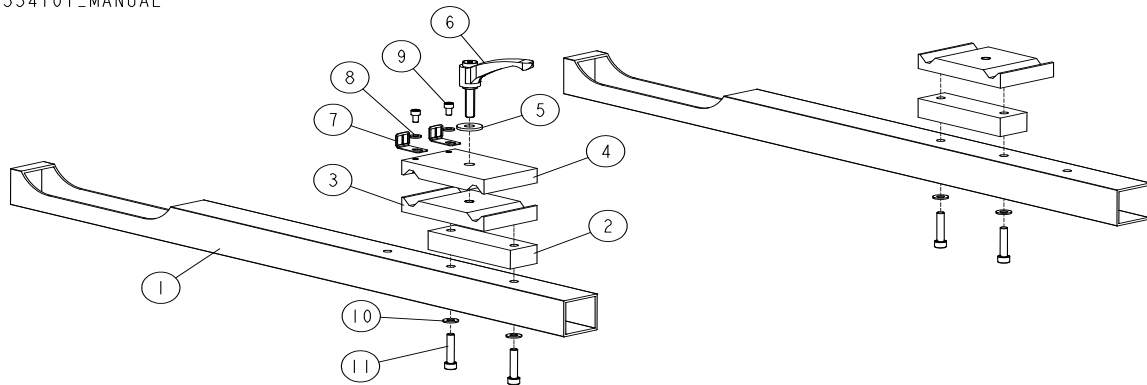

REF	DESCRIPTION (u indicates parts available in assemblies only)	PART #	QTY
-	<b>Material Guide Assembly</b>	554101	1
1	MATERIAL GUIDE	554100-1	2
2	BLOCK, 26X40X130 CONNECTION	533522-1	2
3	BRACKET, ROD MOUNT - LOWER	533523-1	2
4	BRACKET, ROD MOUNT - UPPER	533530-1	1
5	WASHER, 10.5 SPECIAL FLAT ZINC	F81055-6	1
6	HANDLE, ERZ.78 P-M10X40 ADJUSTABLE	533536	1
7	INDICATOR, SCALE	533098	2
8	WASHER, 6.4 FLAT ZINC	F81053-1	2
9	SCREW, M6X10 8.8 HEX SOCKET HEAD CAP ZIN	F81001-12	2
10	WASHER, 8.4 FLAT ZINC	F81054-1	4
11	SCREW, M8X40-8.8 HEX SOCKET HEAD CAP ZIN	F81002-29	4



## 2.25 Press Roller Assembly (No. 533100)

533100\_001  
533100\_MANUAL

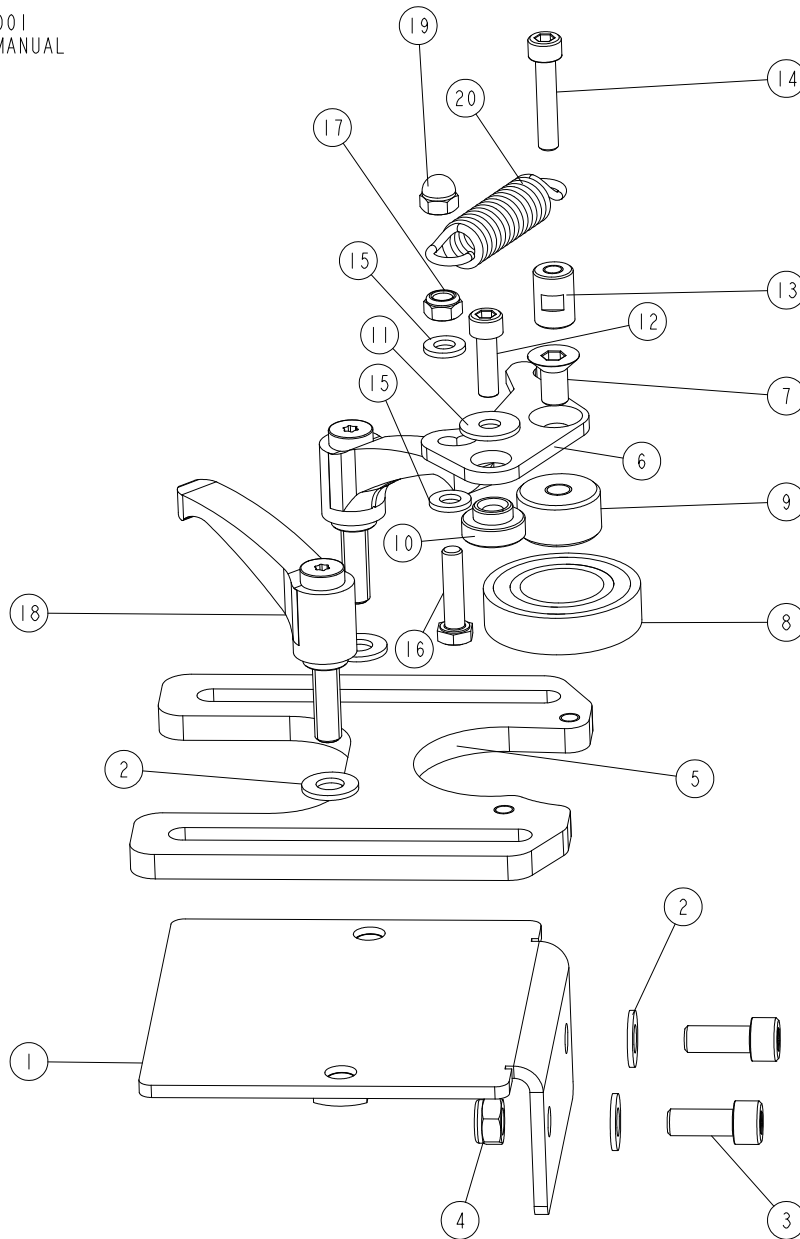

REF.	DESCRIPTION (* indicates parts available in assemblies only)	PART #	QTY
-	<b>ROLLER ASSEMBLY, PRESS</b>	533100	1
1	PLATE WELDMENT, MOUNT	533101-1	1
2	WASHER, 8.4 FLAT ZINC	F81054-1	4
3	SCREW, M8X20-8.8 HEX SOCKET HEAD CAP ZINC	F81002-30	2
4	NUT, M8-8-B HEX NYLON ZINC LOCK	F81032-2	2
5	PLATE, ADJUSTMENT	533103-1	1
6	BRACKET, BEARING MOVABLE	533525-1	1
7	SCREW, M8X16 FE/ZN5 7991 10.9 FLAT SOCKET HEAD CAP	F81002-82	1
8	BEARING, 6005 2RS	089652	1
9	BUSHING, M8/25-13.5 ZINC-PLATED	533529-1	1
10	BUSHING, 6.2/12-10 FLANGED 19-6	533632	1

REF.	DESCRIPTION (* indicates parts available in assemblies only)	PART #	QTY	
11	WASHER, 6.5 SPECIAL FLAT ZINC	F81053-11	1	
12	SCREW, M6X20 8.8 HEX SOCKET HEAD CAP ZINC	F81001-22	1	
13	BUSHING, M6/12-17 ZINC-PLATED	533633-1	1	
14	SCREW, M6X30-8.8 HEX SOCKET HEAD CAP ZINC	F81001-42	1	
15	WASHER, 6.4 FLAT ZINC	F81053-1	2	
16	BOLT, M6X25 -8.8 HEX HEAD FULL THREAD ZINC	F81001-3	1	
17	NUT, M6-8-B HEX NYLON ZINC LOCK	F81031-2	1	
18	LEVER, ERZ.63P-M8X25 ADJUSTABLE	533591	2	
19	NUT, DIN 1587 M6 FE/ZN5 HEX DOMED CAP	F81031-18	1	
20	SPRING, 15X65X2.5 EXTENSION	533571	1	

## 2.26 Upper Cover Assembly 533148

533148\_001\_A  
533148\_MANUAL

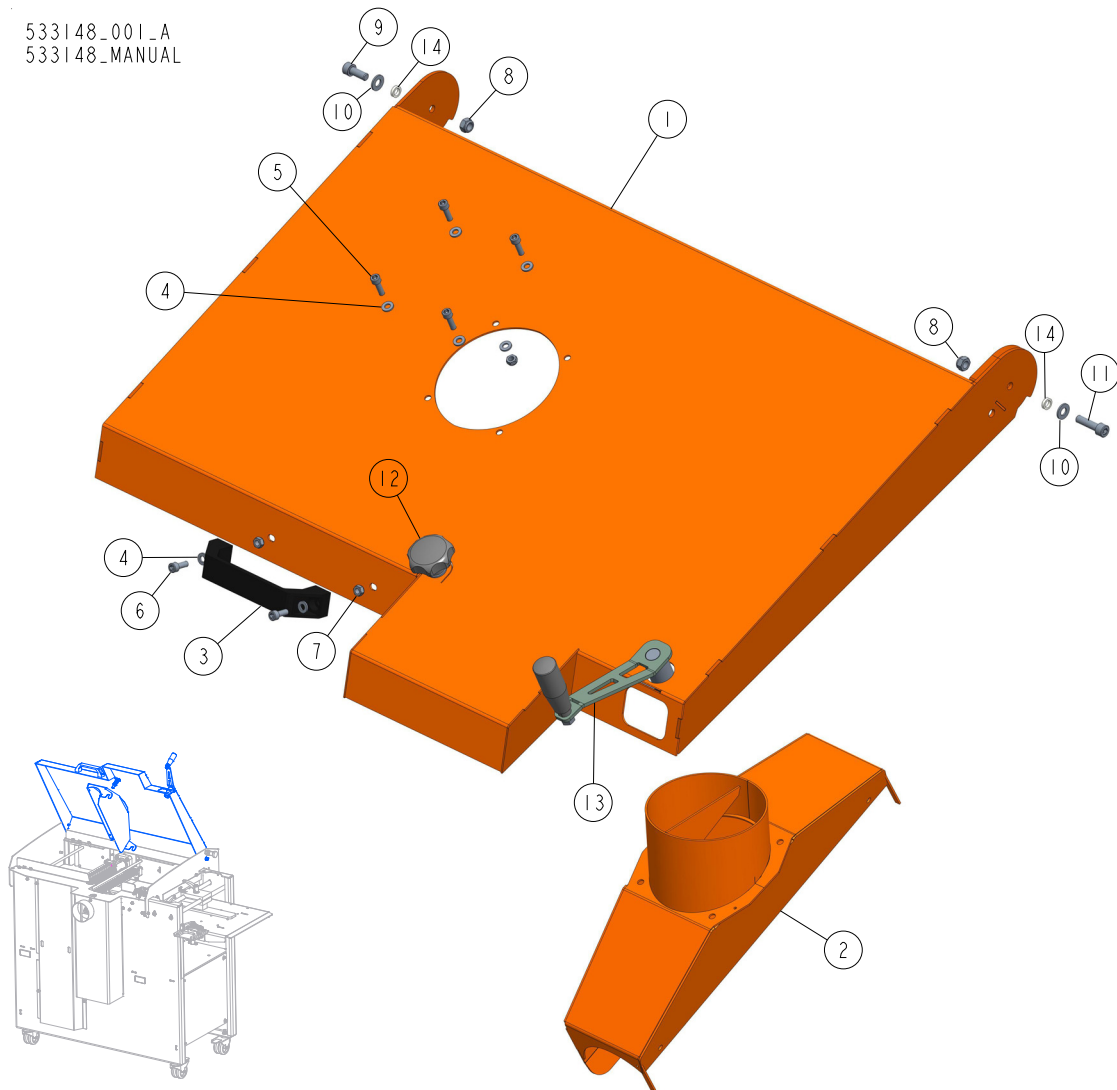

REF	DESCRIPTION (◆ indicates parts available in assemblies only)	PART #	QTY
-	UPPER COVER ASSEMBLY, MP200	533148	1
1	COVER, WELDMENT MP200	533134-1	1
2	CHUTE WELDMENT, SAWDUST	533660-1	1
3	HANDLE, PULL	533506	1
4	WASHER, 6.4 FLAT ZINC	F81053-1	10
5	SCREW, M6X20 8.8 HEX SOCKET HEAD CAP ZIN	F81001-22	4
6	SCREW, M6X16-8.8 HEX SOCKET HEAD CAP ZIN	F81001-21	2
7	NUT, M6-8-B HEX NYLON LOCK ZINC	F81031-2	6
8	NUT, M8-8-B HEX NYLON ZINC LOCK	F81032-2	2
9	BOLT, M8 X 20-8.8 SOCKET HEAD	F81002-30	1
10	WASHER, 8.4 FLAT ZINC	F81054-1	2
11	SCREW, M8X30-8.8 HEX SOCKET HEAD CAP ZIN	F81002-31	1
12	STAR KNOB <a href="#">See Section 2.27</a>	533685	1
13	HANDLE, TABLE SETTING - COMPLETE <a href="#">See Section 2.24</a>	533669	1
14	BUSHING, SPACER	533674	2

**2.27 Star Knob Assembly 533685**

533685\_001  
533685\_MANUAL

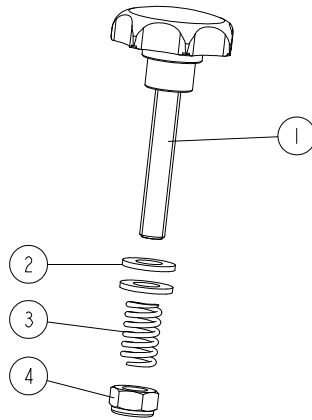

REF.	DESCRIPTION (* indicates parts available in assemblies only)	PART #	QTY
-	<b>KNOB ASSEMBLY, STAR</b>	533685	1
1	KNOB, STAR	533683	1
2	WASHER, 10.5 FLAT ZINC	F81055-1	2
3	SPRING	533677	1
4	NUT, M10-8-B HEX NYLON ZINC LOCK	F81033-1	1

## 2.28 Table Setting Handle (No. 533669)

533669\_001  
533669\_MANUAL

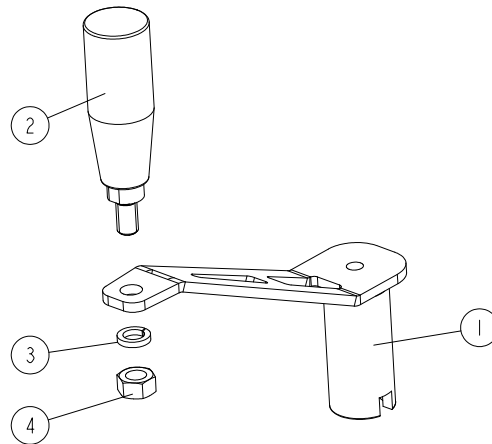

REF.	DESCRIPTION (* indicates parts available in assemblies only)	PART #	QTY	
-	<b>HANDLE, TABLE SETTING - COMPLETE</b>	533669	1	
1	HANDLE ASSEMBLY, TABLE SETTING	533147-1	1	
2	GRIP, CYLINDRICAL	533505	1	
3	WASHER, 8.2 SPLIT LOCK ZINC	F81054-4	1	
4	NUT, M8-8-B HEX ZINC	F81032-1	1	

**2.29 Main Shaft Assembly 533682**

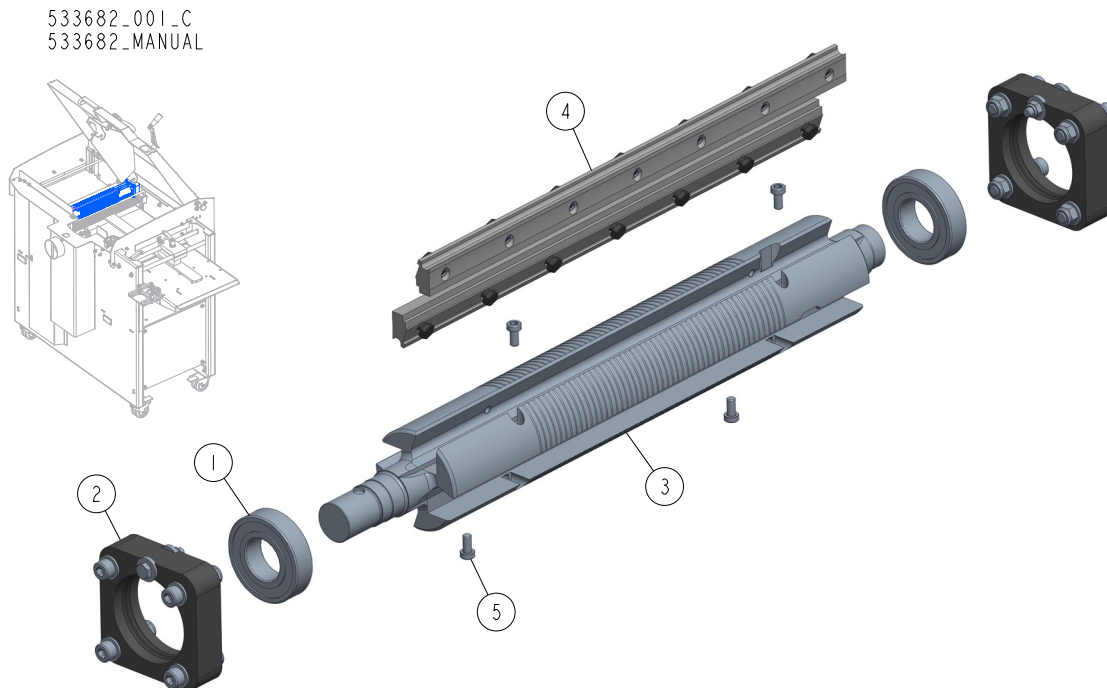

REF	DESCRIPTION (◆ indicates parts available in assemblies only)	PART #	QTY
-	SHAFT ASSEMBLY, DRIVE	533682	1
1	BEARING, 6206 2RSR P6 ROLLING	100787	2
2	HOUSING ASSEMBLY, BEARING <a href="#">See Section 2.31</a>	533593	2
-	SHAFT ASSEMBLY, MAIN	564943	1
3	SHAFT, MAIN	260-138	1
4	MOUNTING WEDGES	241-060	1
5	SCREW, M6X12-10.9 DIN 7984 HEX SOCKET TH	F81001-80	4

## 2.30 Helical Top Cutter Assembly - 564957 (Option)

564957\_001  
564957

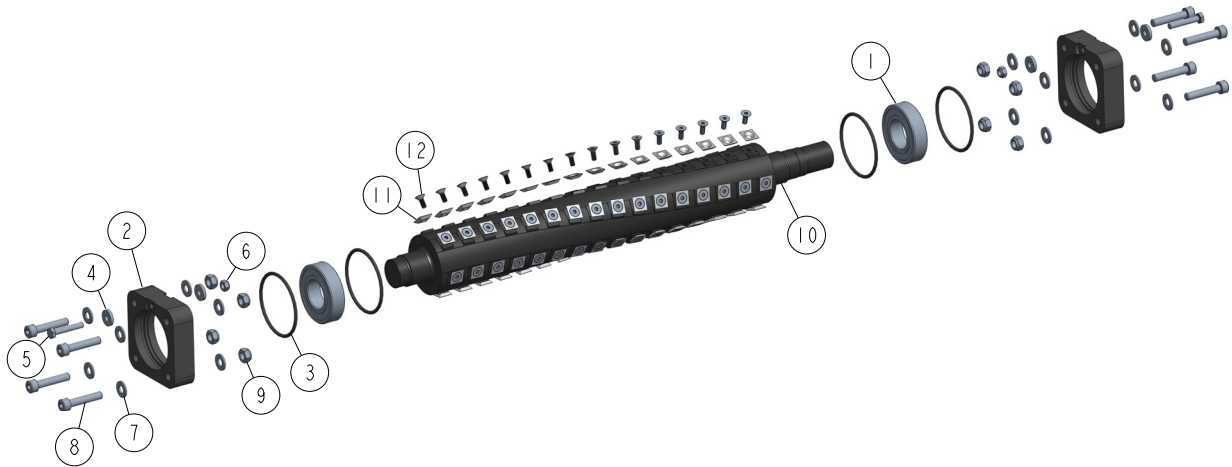

REF	DESCRIPTION (◆ indicates parts available in assemblies only)	PART #	QTY	
-	<b>CUTTER ASSY., MP200 MP220 MP260 HELICAL TOP</b>	564957	1	
1	BEARING, 6206-C- 2HRS-FAG	592793	2	
-	HOUSING ASSEMBLY, BEARING	533593	2	
2	HOUSING, BEARING	533590-1	1	
3	O-RING, BEARING HOUSING	533592	2	
4	WASHER 6,4 ZC DIN 7349	F81053-13	2	
5	BOLT, M6X35-8.8-FE/ZN5 PN-M/82101.	F81001-71	1	
6	NUT, M6-8-B HEX NYLON LOCK ZINC	F81031-2	1	
7	WASHER, 8.4 FLAT ZINC	F81054-1	8	
8	SCREW, M8X40-8.8 HEX SOCKET HEAD CAP ZIN	F81002-29	4	
9	NUT, M8-8-B HEX NYLON ZINC LOCK	F81032-2	4	
10	CUTTER, TSH260TC HELICAL TOP	562640	1	
11	INSERT, REPLACEMENT CARBIDE	TIK19HM	80	
12	SCREW, 10-32X1/2 FH BO; TORX PLUS	F05004-325	80	

**2.31 Bearing Housing Assembly 533593**

533593\_001  
533593\_MANUAL

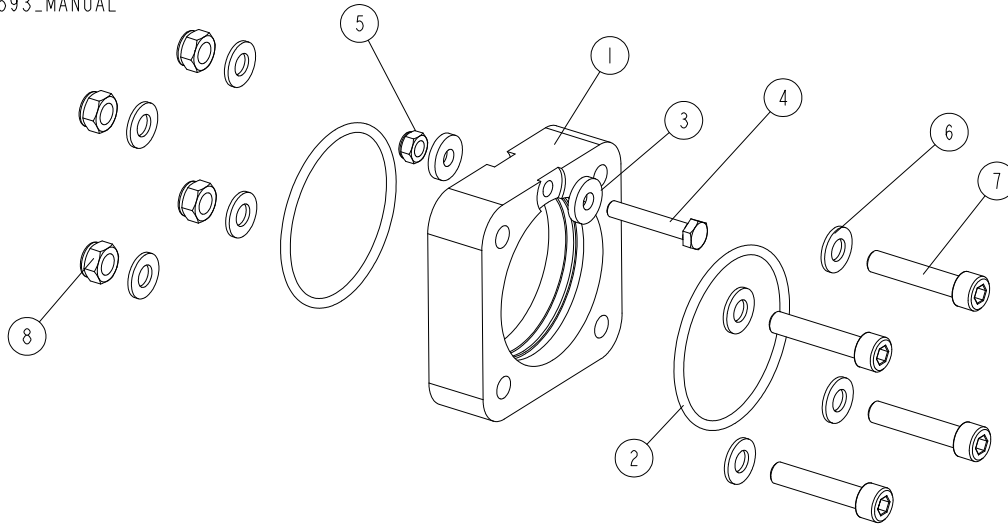

REF.	DESCRIPTION (* indicates parts available in assemblies only)	PART #	QTY
-	<b>Housing Assembly, MP200 Bearing</b>	533593	1
1	HOUSING, BEARING	533590-1	1
2	O-RING, BEARING HOUSING	533592	2
3	WASHER, 6.4 FE/ZN DIN 7349 SPACER	F81053-13	2
4	BOLT, M6X35 -8.8 HEX HEAD ZINC	F81001-71	1
5	NUT, M6-8-B HEX NYLON ZINC LOCK	F81031-2	1
6	WASHER, 8.4 FLAT ZINC	F81054-1	8
7	SCREW, M8X40-8.8 HEX SOCKET HEAD CAP ZINC	F81002-29	4
8	NUT, M8-8-B HEX NYLON ZINC LOCK	F81032-2	4



## 2.32 Feed Assembly 533558

533558\_001  
533558\_MANUAL

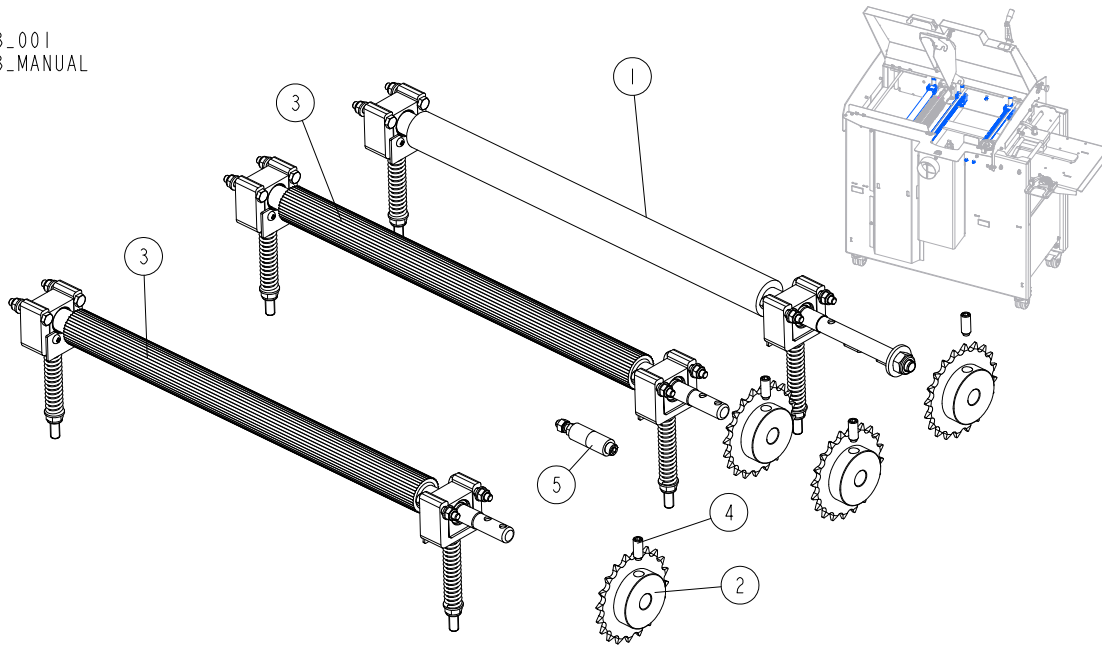

REF.	DESCRIPTION (* indicates parts available in assemblies only)	PART #	QTY
-	<b>FEED ASSEMBLY, MP200</b>	533558 <sup>1</sup>	1
1	SHAFT ASSEMBLY, W/PROTECTIVE COVER <a href="#">See Section 2.29</a>	533581	1
2	SPROCKET, Z=20; 1/2"X 3/16"(CHAIN 083-1)	533109	4
3	SHAFT ASSEMBLY, DRIVE <a href="#">See Section 3.27</a>	533580	2
4	SCREW, M8X20-45H ISO4028 DIN915 SET	F81002-77	4
5	TENSIONER, CHAIN <a href="#">See Section 2.33</a>	533583	1

<sup>1</sup> The assembly also includes:

- 533106 - chain 083-1; p-1/2"; length = 0.7747 m (61 links)
- 533107 - chain 083-1; p-1/2"; length = 0.5588 m (43 links + 1 offset link)
- 533128 - master link for chain 083-1 - 2 pcs

**2.33 Chain Tensioner 533583**

533583\_001  
533583\_MANUAL

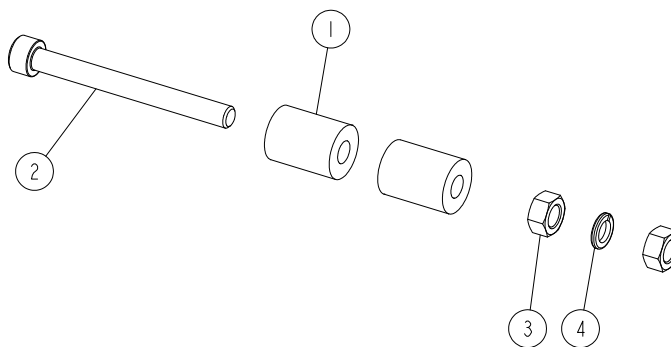

REF.	DESCRIPTION (* indicates parts available in assemblies only)	PART #	QTY
-	TENSIONER, CHAIN	533583	1
1	BUSHING, SPACER	R80671-6	2
2	SCREW, M6X60-8.8 HEX SOCKET HEAD CAP ZINC	F81001-44	1
3	NUT, M6 8 HEX ZINC	F81031-1	2
4	WASHER, Z 6.1 SPLIT LOCK ZINC	F81053-3	1

2.34 Drive Shaft Assembly (No. 533580)

533580\_001\_A  
533580\_MANUAL

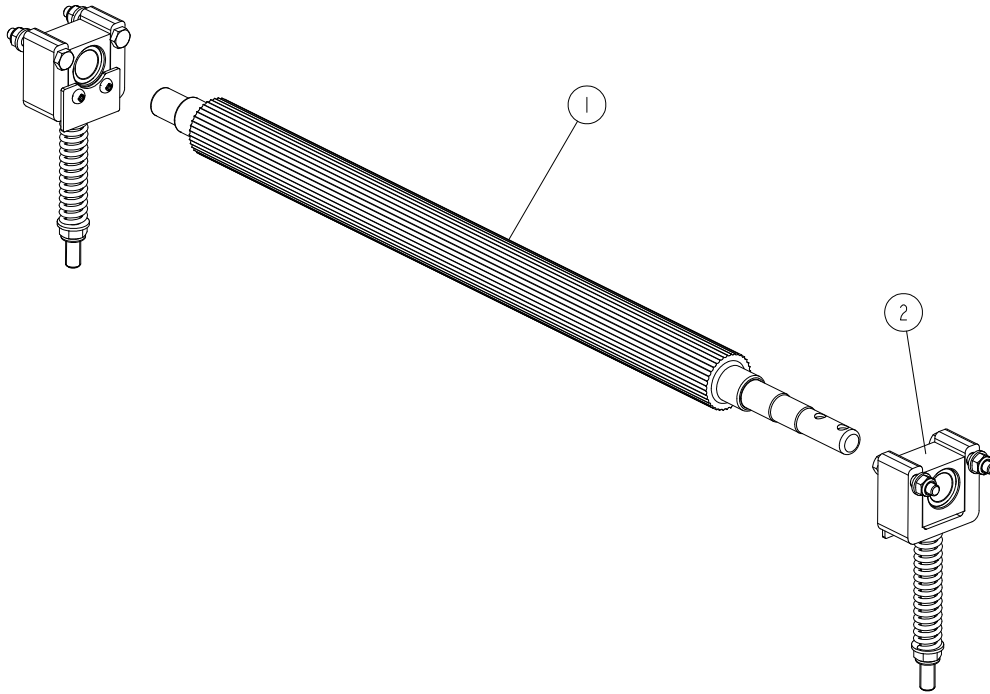

REF.	DESCRIPTION (* indicates parts available in assemblies only)	PART #	QTY	
-	SHAFT ASSEMBLY, DRIVE	533580	1	
1	SHAFT, STEEL DRIVE	533513-1	1	
2	BEARING ASSEMBLY, SLIDE <a href="#">See Section 2.36</a>	533520	2	

**2.35 Shaft w/Protective Cover (No. 533581)**

533581\_001\_A  
533581\_MANUAL

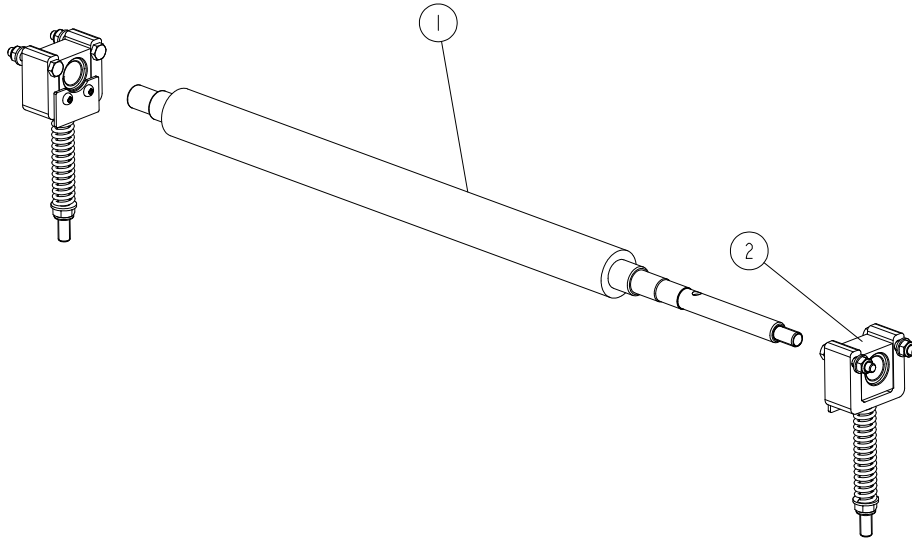

REF.	DESCRIPTION (* indicates parts available in assemblies only)	PART #	QTY	
-	SHAFT ASSEMBLY, W/PROTECTIVE COVER	533581	1	
1	SHAFT W/PROTECTIVE COVER	533512	1	
2	BEARING ASSEMBLY, SLIDE <a href="#">See Section 2.36</a>	533520	2	

## 2.36 Slide Bearing Assembly (No. 533520)

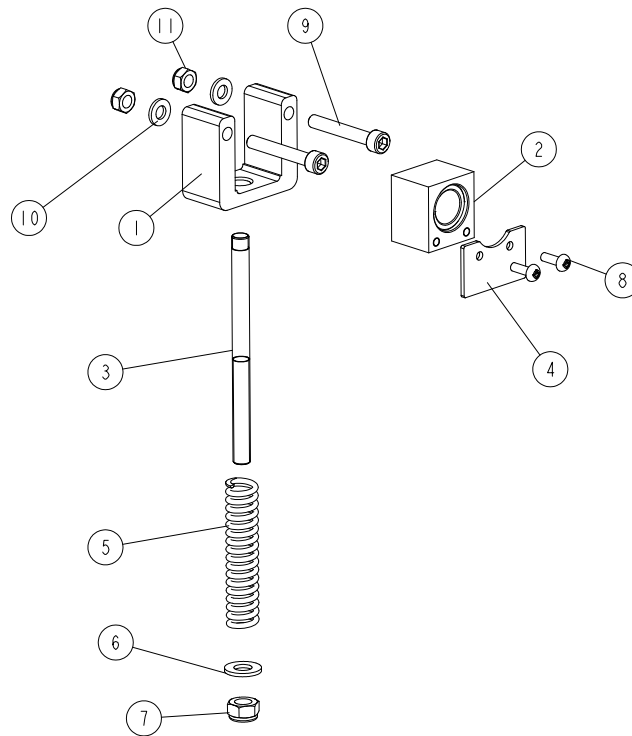
533520\_001\_B  
533520\_MANUAL

REF	DESCRIPTION (◆ indicates parts available in assemblies only)	PART #	QTY
-	BEARING ASSEMBLY, SLIDE	533520	1
1	HOUSING, SLIDE BEARING	533514	1
2	SLIDE BLOCK ASSEMBLY	537575	1
3	ROD, SHAFT TENSION	546898-1	1
4	COVER, RUBBER	533516	1
5	SPRING	533519-1	1
6	WASHER, 8.4 FLAT,ZINC	F81054-1	1
7	NUT, M8-8-B HEX NYLON ZINC LOCK	F81032-2	1
8	SCREW M4X12 PHILLIPS ZC 5.8 DIN 7985	F81011-43	2
9	BOLT M6X40 HEX	F81001-124	2
10	WASHER, M6, FLAT,ZINC	F81053-1	2
11	NUT, M6-8-B HEX NYLON ZINC LOCK	F81031-2	2

## 2.37 Up/Down Assembly 533115

533115\_001\_A  
533115\_MANUAL

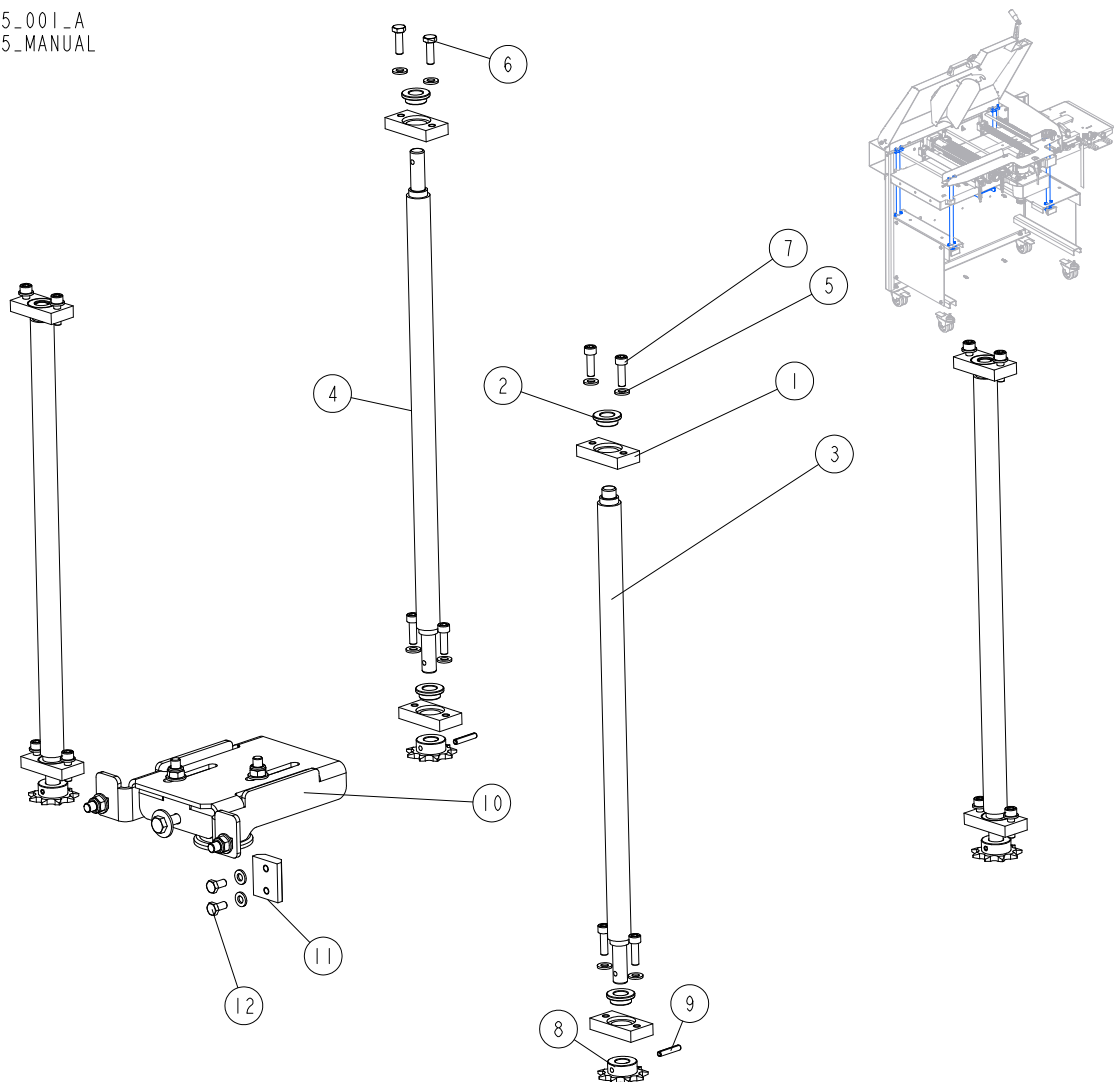

REF.	DESCRIPTION (* indicates parts available in assemblies only)	PART #	QTY
-	<b>UP/DOWN ASSEMBLY</b>	533115 <sup>1</sup>	1
1	BLOCK	533113-1	8
2	BUSHING, 12/18-8 FLANGE 24-3	546901	8
3	SCREW, TR20X4 ACME	533116	3
4	SCREW, TR20X4 HIGH ACME	533112	1
5	WASHER, 6.4 FLAT ZINC	F81053-1	18
6	BOLT, M6X20 8.8 HEX HEAD FULL THREAD ZINC	F81001-2	2
7	SCREW, M6X20 8.8 HEX SOCKET HEAD CAP ZINC	F81001-22	14
8	SPROCKET, Z=9; 1/2"X 3/16"(CHAIN 083-1)	533111	4
9	PIN, ROLL	F81044-13	4
10	CHAIN TENSIONER ASSEMBLY <a href="#">See Section 2.38</a>	533570	1
11	BLOCK, CHAIN SLIDE	533681	1
12	BOLT, M6X12 8.8 HEX HEAD FULL THREAD ZINC	F81001-7	2

<sup>1</sup> The assembly also includes:

-533105 - chain 083-1; p-1/2"; length=2.8829 m (225 links)

-533128 - master link for chain 083-1 - 1 pc

## 2.38 Chain Tensioner Assembly 533570

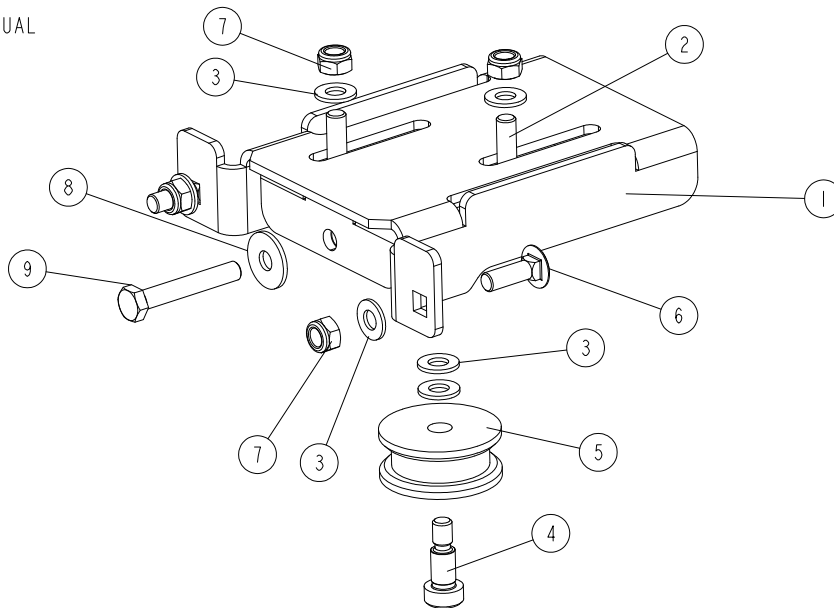
533570\_001  
533570\_MANUAL

REF.	DESCRIPTION (* indicates parts available in assemblies only)	PART #	QTY
-	<b>CHAIN TENSIONER ASSEMBLY</b>	533570	1
1	PLATE, CHAIN TENSIONER	533575-1	1
2	BRACKET, TENSIONER SLIDE	533572-1	1
3	WASHER, 8.4 FLAT ZINC	F81054-1	6
4	BOLT, ISO 7379-10-M8-16 12.9 SHOULDER	F81003-139	1
5	ROLLER, TENSIONER	533576	1
6	BOLT, M8X25-8.8-B ZINC MUSHROOM HEAD SQUARE NECK	F81002-59	2
7	NUT, M8-8-B HEX NYLON ZINC LOCK	F81032-2	4
8	WASHER, ISO 7093-1-8-200 HV-A2E.	F81054-11	1
9	BOLT, M8X50 -8.8 HEX HEAD FULL THREAD ZINC	F81002-19	1

**2.39 Table 546819**

546819\_001\_A  
546819\_MANUAL

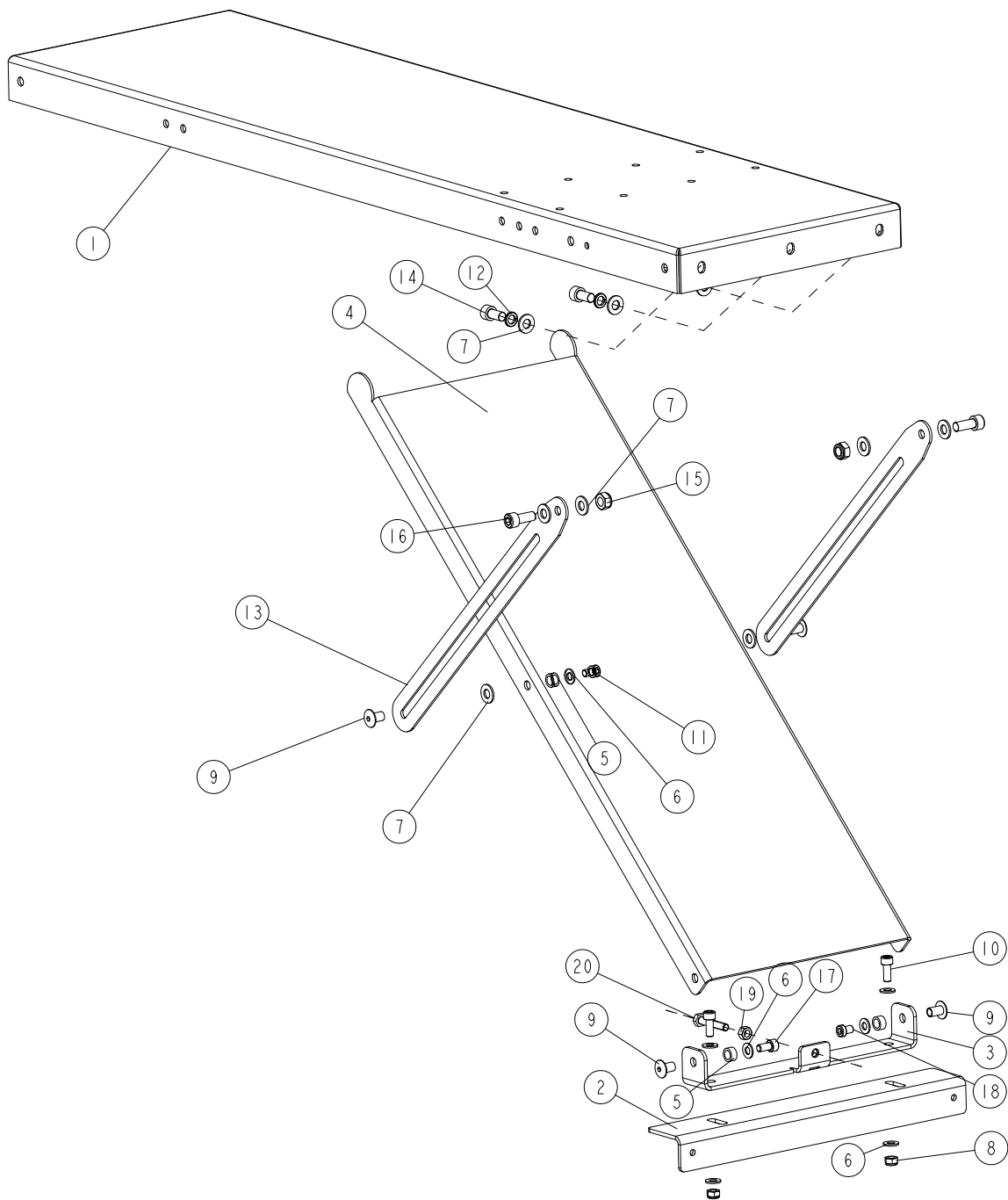

REF.	DESCRIPTION (* indicates parts available in assemblies only)	PART #	QTY
-	<b>TABLE, MP200</b>	546819	1
1	PLATE, TABLE 265	265-100-1	1
2	ANGLE SECTION	265-104-1	1
3	CHANNEL BAR, MP260 WELDMENT	541453-1	1
4	PLATE, TABLE SUPPORT 265-000	265-101-1	1



REF.	DESCRIPTION (* indicates parts available in assemblies only)	PART #	QTY	
5	BUSHING 10.3/15-7.5	533724	4	
6	WASHER 8.4 ZC DIN 126 ISO 7091 FLAT ZINC	F81054-1	8	
7	WASHER, 10.5 FLAT ZINC	F81055-1	9	
8	NUT, M8-8-B HEX NYLON ZINC LOCK	F81032-2	2	
9	NUT, ERICSON M8 AN88 COLLAR ZINC	F81032-33	4	
10	SCREW, M8X20-8.8 HEX SOCKET HEAD CAP ZINC	F81002-30	2	
11	SCREW, M8X10-8.8 HEX SOCKET HEAD CAP ZINC	F81002-32	2	
12	WASHER, Z 10.2 SPLIT LOCK ZINC	F81055-2	3	
13	SLIDER, TABLE	533728-1	2	
14	SCREW, M10X20 8.8 HEX SOCKET HEAD CAP ZINC	F81003-108	3	
15	NUT, M10-8-B HEX NYLON ZINC LOCK	F81033-1	2	
16	SCREW, M10X25 8.8 HEX SOCKET HEAD CAP ZINC	F81003-32	2	
17	SCREW, M8X16-8.8 HEX SOCKET HEAD CAP ZINC	F81002-39	1	
18	SCREW, M8X12 SOCKET HEAD/10.9	F81002-110	1	
19	NUT, M8-8-B DIN 934HEX ZINC	F81032-1	1	
20	BOLT, M8X45-8.8 HEX HEAD ZINC	F81002-17	1	

## 2.40 Side Clamp, MP200/MP220 (No. 564986) - additional equipment

564986\_001  
564986\_MANUAL

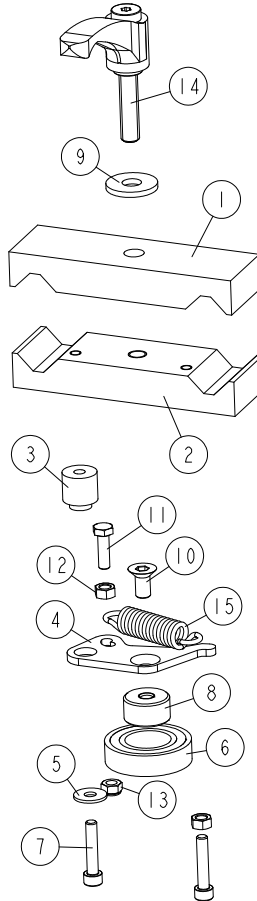

REF.	DESCRIPTION (* indicates parts available in assemblies only)	PART #	QTY
-	<b>SIDE CLAMP, MP200/220</b>	564986	1
1	PLATE, BASIC UPPER	533527-1	1
2	PLATE, BASIC LOWER	533526-1	1
3	BUSHING, 6.2/19-20.3 12-4.3	533528	1
4	BRACKET, BEARING MOVABLE	533525-1	1
5	WASHER, 6.5 SPECIAL FLAT ZINC	F81053-11	1
6	BEARING, 6005 2RS PN-85/M-86100	089652	1
7	SCREW, M6X30-8.8 HEX SOCKET HEAD CAP ZIN	F81001-42	2
8	BUSHING, M8/25-13.5 ZINC-PLATED	533529-1	1
9	WASHER, 10.5 SPECIAL FLAT ZINC	F81055-6	1
10	SCREW, M8X16-10.9 FE/ZN5 DIN7991 FLAT SO	F81002-82	1
11	BOLT, M6X20 8.8 HEX HEAD FULL THREAD ZIN	F81001-2	1
12	NUT, M6 8 HEX ZINC	F81031-1	2
13	NUT, M6-8-B HEX NYLON ZINC LOCK	F81031-2	1
14	HANDLE, ERZ.78 P-M10X40 ADJUSTABLE	533536	1
15	SPRING, 15X65X2.5 EXTENSION	533571	1

---

## SECTION 3 MOTOR KITS MP200 CE

## 3.1 PRO Motor Kit 533131

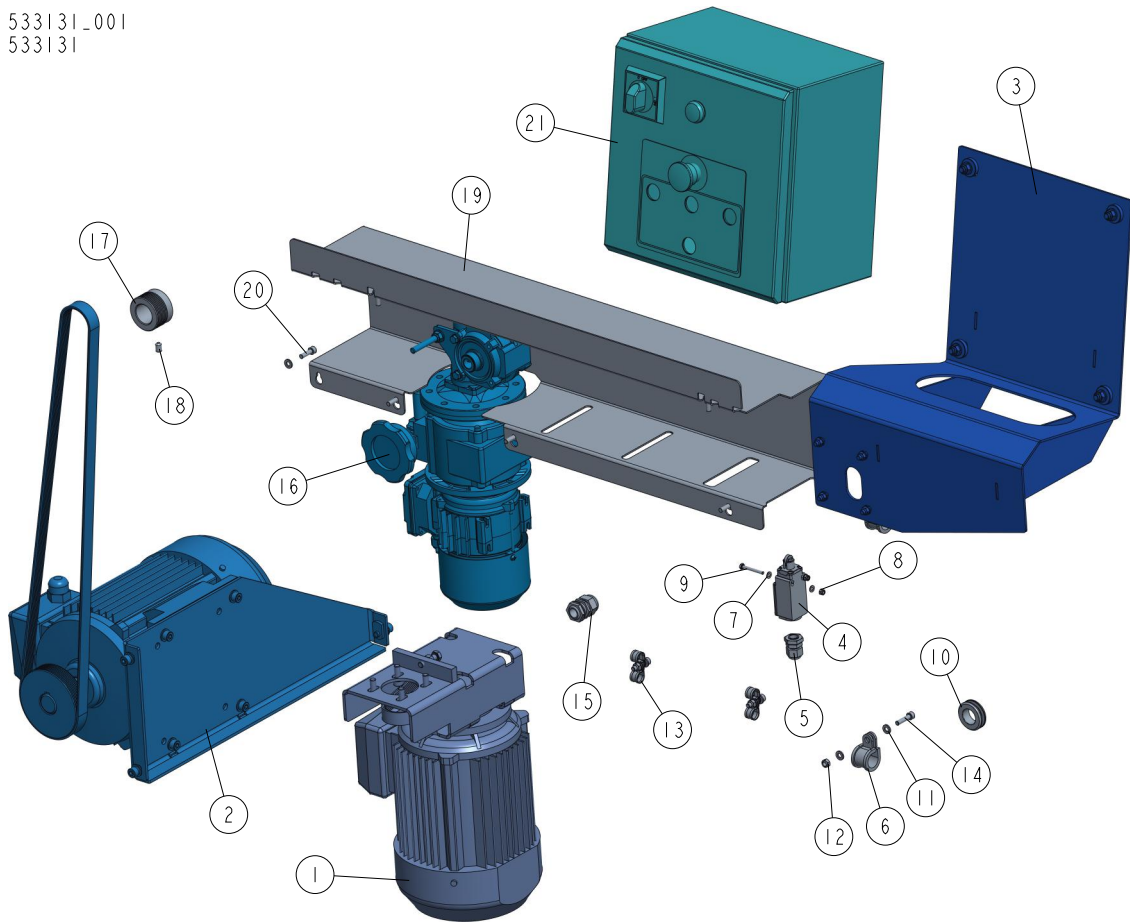
533131\_001  
533131

REF	DESCRIPTION (◆ indicates parts available in assemblies only)	PART #	QTY
-	MOTOR KIT, PRO MP200EH 3X400V CE	533131	1
-	MOTOR KIT, PRO MP200EB 3x230V CE	533131-2	1
-	MOTOR KIT, PRO MP200EA 1x230V CE	533131-6	1
1	SIDE CUTTER DRIVE <a href="#">See Section 3.3</a>	533647	1
	SIDE CUTTER DRIVE <a href="#">See Section 3.4</a>	533647-6 <sup>1</sup>	1
2	DRIVE, HORIZONTAL CUTTER PRO <a href="#">See Section 3.5</a>	533645-P	1
	DRIVE, HORIZONTAL CUTTER PRO <a href="#">See Section 3.7</a>	533645-6 <sup>2</sup>	1
3	ELECTRIC BOX MOUNTING BRACKET COMPLETE <a href="#">See Section 3.16</a>	533508	1
4	SWITCH, GLCB01C LIMIT	100910	1
5	GLAND, DP 9/H CABLE	F81096-2	1
6	CLIP, RSGU 1.20/20 RETAINING	F81087-2	2
7	WASHER, 4.3 FLAT ZINC	F81051-2	4
8	NUT, M4-B HEX NYLON ZINC LOCK	F81029-1	2
9	BOLT, M4X35-8.8 HEX HEAD FULL THREAD ZIN	F81011-7	2
10	GROMMET, 22MM RUBBER	087400	1
11	WASHER, 6.4 FLAT ZINC	F81053-1	12
12	NUT, M6-8-B HEX NYLON ZINC LOCK	F81031-2	3
13	CLIP, RSGU 1.10/12W1 RETAINING	086861	4
14	SCREW, M6X25 -8.8-HEX SOCKET HEAD CAP ZI	F81001-41	3

REF	DESCRIPTION (◆ indicates parts available in assemblies only)	PART #	QTY	
15	GLAND, DP 20 HML. CABLE	F81096-41	1	
16	DRIVE, PRO FEED <a href="#">See Section 3.12</a>	533650	1	
	DRIVE, PRO FEED <a href="#">See Section 3.14</a>	533650-6 <sup>3</sup>	1	
17	PULLEY, MULTI-GROOVE SMALL ALUMINIUM	601602	1	
18	SCREW M8X12 HSS W/CONE POINT ZC 45H DIN	F81002-105	1	
19	GUARD, FEED DRIVE	533666-1	1	
20	SCREW, M6X20 8.8 HEX SOCKET HEAD CAP ZIN	F81001-22	6	
21	BOX, ELECTRICAL - COMPLETE MP200EH <a href="#">See Section 3.17</a>	532820	1	
	BOX, ELECTRICAL - COMPLETE MP200EB	532820-2 <sup>4</sup>	1	
	BOX, ELECTRICAL - COMPLETE MP200EA	532820-6 <sup>5</sup>	1	

<sup>1</sup> Included in 533131-6

<sup>2</sup> Included in 533131-6

<sup>3</sup> Included in 533131-6

<sup>4</sup> Included in 533131-2

<sup>5</sup> Included in 533131-6

## 3.2 ECO Motor Kit 533132

533132\_001\_B  
533132\_MANUAL

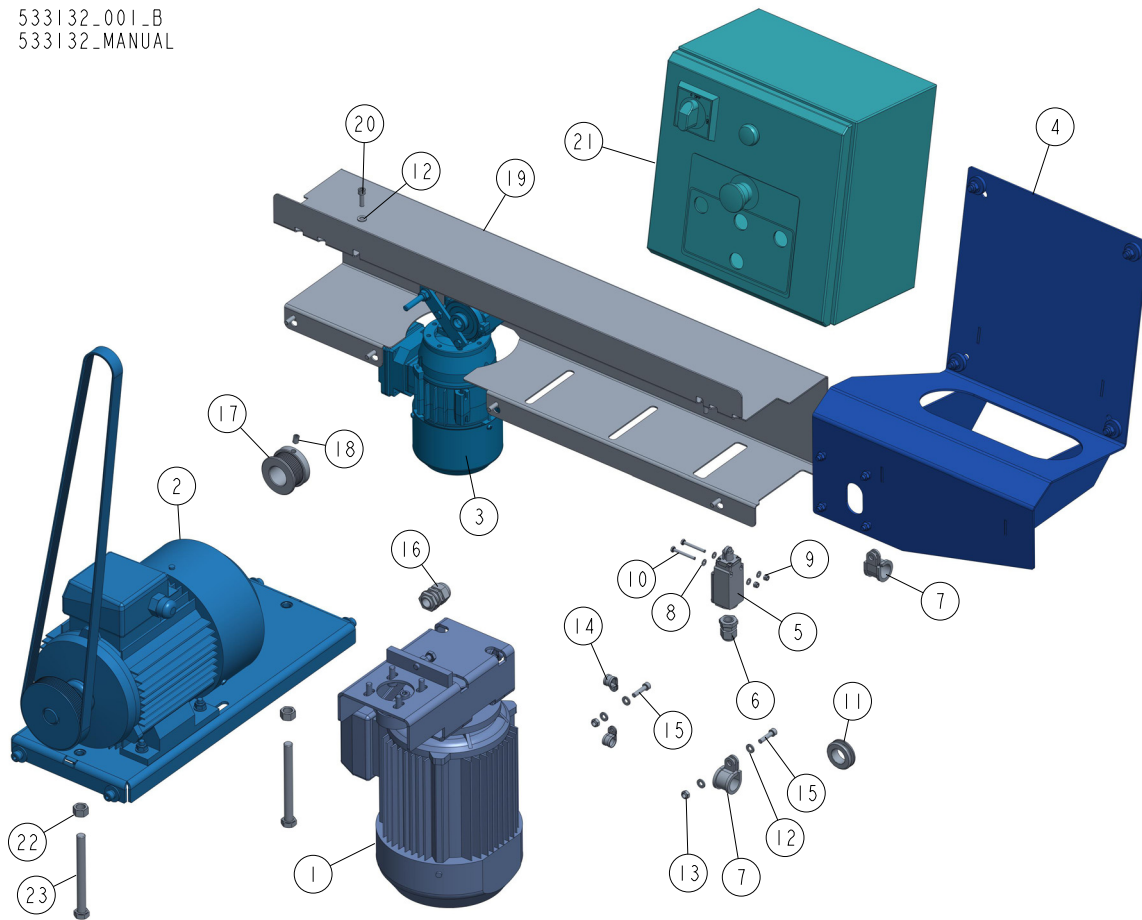

REF	DESCRIPTION (◆ indicates parts available in assemblies only)	PART #	QTY	
-	MOTOR KIT, ECO MP200EH 3x400V CE	533132	1	
-	MOTOR KIT, ECO MP200EB 3x230V CE	533132-2	1	
-	MOTOR KIT, ECO MP200EC 3x460V CE	533132-4	1	
-	MOTOR KIT, ECO MP200EA 1x230V CE	533132-6	1	
1	SIDE CUTTER DRIVE <a href="#">See Section 3.3</a>	533647	1	
	SIDE CUTTER DRIVE <a href="#">See Section 3.4</a>	533647-6 <sup>1</sup>	1	
2	DRIVE, HORIZONTAL CUTTER ECO <a href="#">See Section 3.6</a>	533645	1	
	DRIVE, HORIZONTAL CUTTER ECO <a href="#">See Section 3.7</a>	533645-6 <sup>2</sup>	1	
3	DRIVE, MP200 ECO FEED <a href="#">See Section 3.8</a>	533638	1	
	DRIVE, MP200 ECO FEED <a href="#">See Section 3.10</a>	533638-6 <sup>3</sup>	1	
4	ELECTRIC BOX MOUNTING BRACKET COMPLETE <a href="#">See Section 3.16</a>	533508	1	
5	SWITCH, GLCB01C LIMIT	100910	1	
6	GLAND, DP 9/H CABLE	F81096-2	1	
7	CLIP, RSGU 1.20/20 RETAINING	F81087-2	2	
8	WASHER, 4.3 FLAT ZINC	F81051-2	4	
9	NUT, M4-B HEX NYLON ZINC LOCK	F81029-1	2	
10	BOLT, M4X35-8.8 HEX HEAD FULL THREAD ZIN	F81011-7	2	
11	GROMMET, 22MM RUBBER	087400	1	

REF	DESCRIPTION (◆ indicates parts available in assemblies only)	PART #	QTY	
12	WASHER, 6.4 FLAT ZINC	F81053-1	12	
13	NUT, M6-8-B HEX NYLON ZINC LOCK	F81031-2	3	
14	CLIP, RSGU 1.10/12W1 RETAINING	086861	4	
15	SCREW, M6X25 -8.8-HEX SOCKET HEAD CAP ZI	F81001-41	3	
16	GLAND, DP 20 HML. CABLE	F81096-41	1	
17	PULLEY, MULTI-GROOVE SMALL ALUMINIUM	601602	1	
18	SCREW M8X12 HSS W/CONE POINT ZC 45H DIN	F81002-105	1	
19	GUARD, FEED DRIVE	533666-1	1	
20	SCREW, M6X20 8.8 HEX SOCKET HEAD CAP ZIN	F81001-22	6	
21	BOX, ELECTRICAL - COMPLETE MP200EH <a href="#">See Section 3.17</a>	532820	1	
	BOX, ELECTRICAL - COMPLETE MP200EB	532820-2 <sup>4</sup>	1	
	BOX, ELECTRICAL - COMPLETE MP200EC	532820-4 <sup>5</sup>	1	
	BOX, ELECTRICAL - COMPLETE MP200EA	532820-6 <sup>6</sup>	1	
22	NUT, M12, HEXAGON, GRADE 5.8, ZINC	F81034-1	2	
23	BOLT, M12X120-8.8 HEX HEAD ZINC, BOLT M12X120 8.8 FE/ZN5	F81004-38	2	

<sup>1</sup> Included in 533132-6<sup>2</sup> Included in 533132-6<sup>3</sup> Included in 533132-6<sup>4</sup> Included in 533132-2<sup>5</sup> Included in 533132-4<sup>6</sup> Included in 533132-6

## 3.3 Side Cutter Drive 533647

533647\_001.D  
533647\_MANUAL

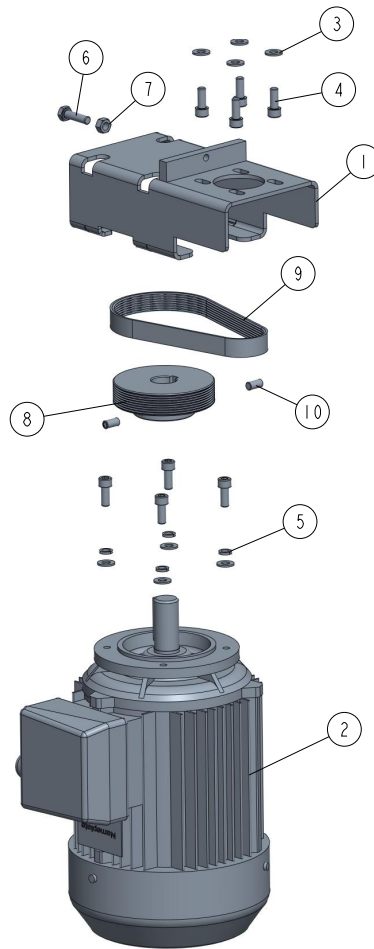

REF	DESCRIPTION (u indicates parts available in assemblies only)	PART #	QTY	
-	<b>SIDE CUTTER DRIVE</b>	533647	1	
1	PLATE WELDMENT, MP200 MOTOR PAINTED MOUN	533649-1	1	
2	MOTOR 3SIEK90L2A, B14/C140, 3KW, 2900 R.	537385	1	
3	WASHER, 8,4-FLAT ZINC	F81054-1	8	
4	SCREW, M8X20-8.8 HEX SOCKET HEAD CAP ZIN	F81002-30	8	
5	WASHER, 8,2 SPLIT LOCK ZINC	F81054-4	4	
6	BOLT M8X30 HH ZC FT 8.8 DIN 933	F81002-7	1	
7	NUT M8 ZC 8 DIN 934	F81032-1	1	
8	PULLEY, MULTI-GROOVE ALUMINIUM	533585	1	
9	BELT, 8 PJ 457 MULTI-RIBBED	533680	1	
10	SCREW M8X16 HSS W/FLAT POINT ZC 45H DIN	F81002-124	2	



3.4 Side Cutter Drive 533647-6

533647-6\_001  
533647-6

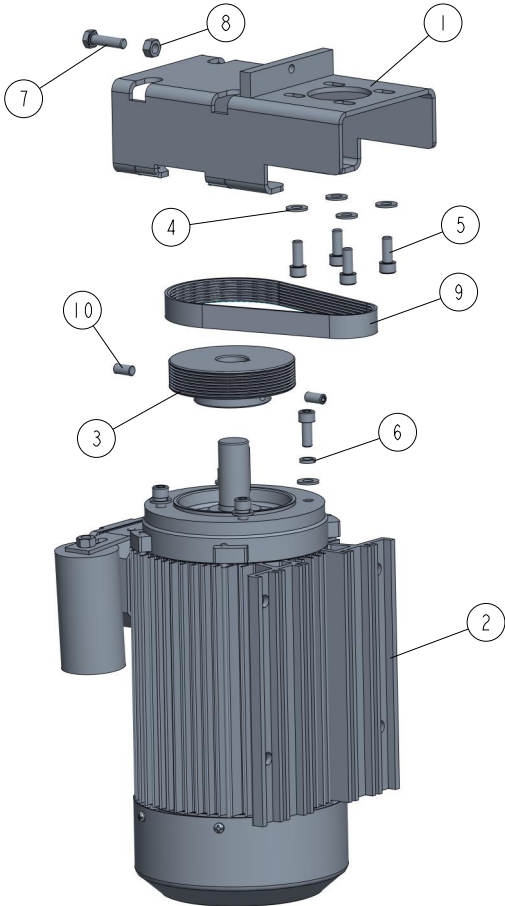

REF	DESCRIPTION (◆ indicates parts available in assemblies only)	PART #	QTY	
-	<b>SIDE CUTTER DRIVE</b>	533647-6	1	
1	PLATE WELDMENT, MP200 MOTOR PAINTED MOUN	533649-1	1	
2	MOTOR SELHR90-2M2 IMB34/2 2,7KW 230V 4,	533651	1	
3	PULLEY, MULTI-GROOVE ALUMINIUM	533585	1	
4	WASHER, 8,4-FLAT ZINC	F81054-1	8	
5	SCREW, M8X20-8.8 HEX SOCKET HEAD CAP ZIN	F81002-30	8	
6	WASHER, 8.2 SPLIT LOCK	F81054-4	4	
7	BOLT, M8X30 8.8 HEX HEAD FULL THREAD ZIN	F81002-7	1	
8	NUT M8 ZC 8 DIN 934	F81032-1	1	
9	BELT, 8 PJ 457 MULTI-RIBBED	533680	1	
10	SCREW M8X16 HSS W/FLAT POINT ZC 45H DIN	F81002-124	2	

## 3.5 Horizontal Cutter PRO Drive 533645-P

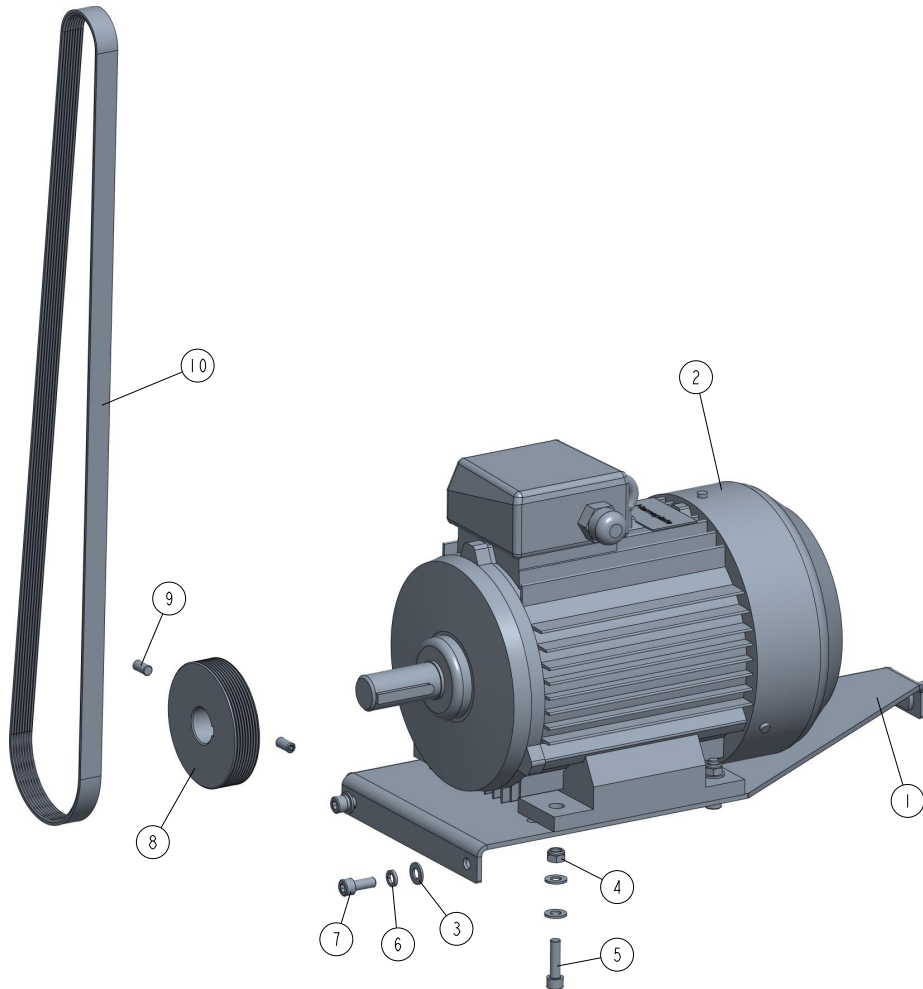
533645-P\_001  
533645-P

REF	DESCRIPTION (◆ indicates parts available in assemblies only)	PART #	QTY	
-	<b>DRIVE, HORIZONTAL CUTTER PRO</b>	533645-P	1	
1	PLATE WELDMENT, ENGINE MOUNT	533565-1	1	
2	MOTOR, 3SIE100L2A 4KW 2900 R.P.M. 50HZ	537387	1	
3	WASHER, 8.4 ZINC FLAT	F81054-1	11	
4	NUT, M8-8-B HEX NYLON ZINC LOCK	F81032-2	4	
5	BOLT, M8 X 30-8.8 SOCKET HEAD	F81002-31	4	
6	WASHER, 8.2 SPLIT LOCK ZINC	F81054-4	3	
7	SCREW, M8 X 20-8.8 HEX SOCKET HEAD CAP Z	F81002-30	3	
8	SHEAVE, MP200 PRO MULTI-GROOVE	533585-P	1	
9	SCREW M8X16 HSS W/FLAT POINT ZC 45H DIN	F81002-124	2	
10	BELT, 8 PJ 1355 MULTI-RIBBED	533679	1	

### 3.6 Horizontal Cutter ECO Drive 533645

533645\_001\_C  
533645\_MANUAL

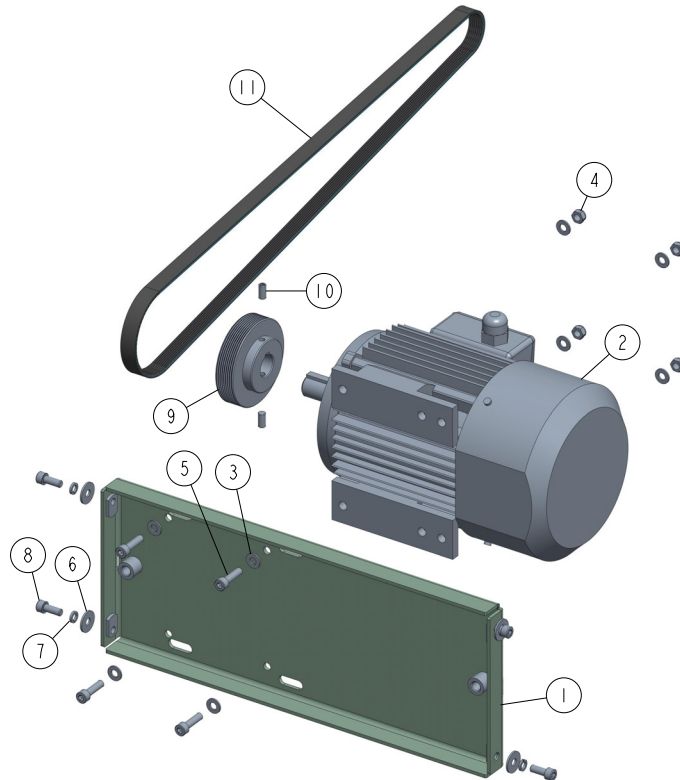

REF	DESCRIPTION (◆ indicates parts available in assemblies only)	PART #	QTY
-	<b>DRIVE, HORIZONTAL CUTTER ECO</b>	533645	1
1	MOTOR PLATE WELDED / PAINT	534200-1	1
2	MOTOR 3SIE90L2A, 3KW, 2900 R.P.M, 50HZ	537386	1
3	WASHER, 8.4 FLAT ZINC	F81054-1	8
4	NUT, M8-8-B HEX NYLON ZINC LOCK	F81032-2	4
5	SCREW, M8X30-8.8 HEX SOCKET HEAD CAP ZIN	F81002-31	4
6	WASHER, 8.5 SPECIAL FLAT ZINC	F81054-11	4
7	WASHER, 8.2 SPLIT LOCK	F81054-4	4
8	BOLT, M8 X 20-8.8 SOCKET HEAD	F81002-30	4
9	PULLEY, MULTI-GROOVE ALUMINIUM	533585	1
10	SCREW M8X16 HSS W/FLAT POINT ZC 45H DIN	F81002-124	2
11	BELT, 8 PJ 1355 MULTI-RIBBED	533679	1

## 3.7 Horizontal Cutter Drive 533645-6

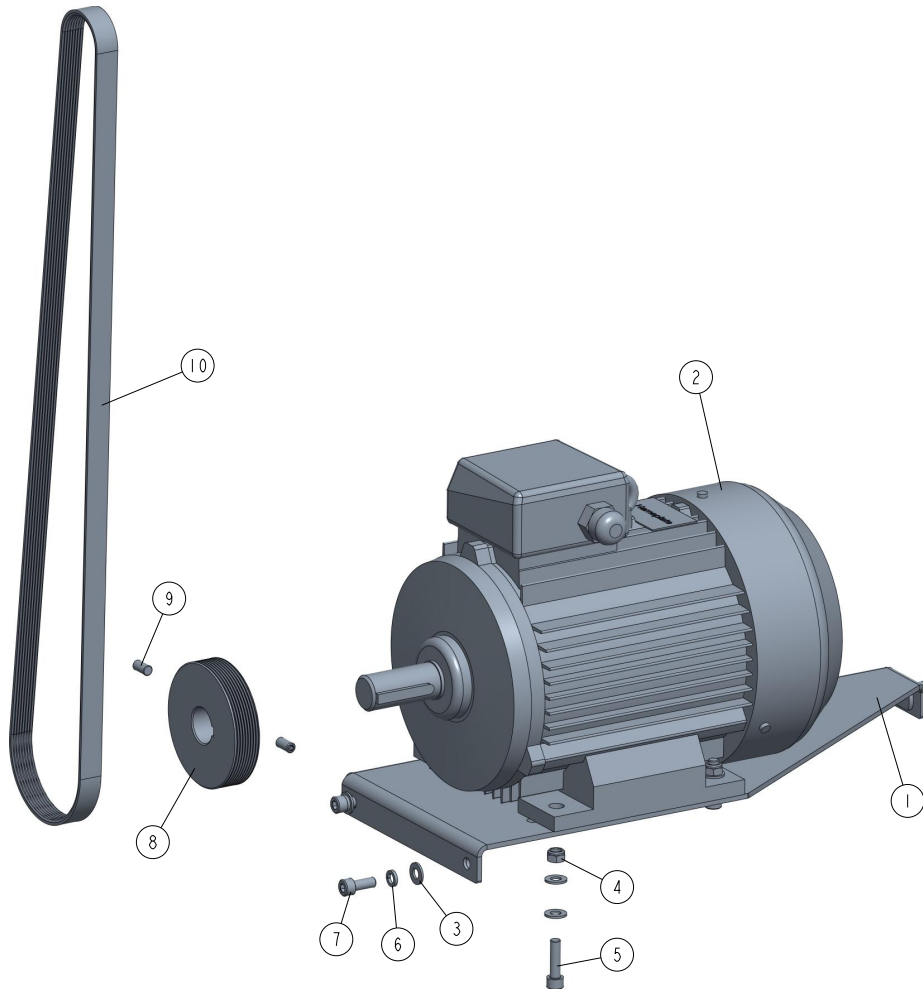
533645-P\_001  
533645-P

REF	DESCRIPTION (◆ indicates parts available in assemblies only)	PART #	QTY	
-	<b>DRIVE, HORIZONTAL CUTTER 230V</b>	533645-6	1	
1	PLATE WELDMENT, ENGINE MOUNT	533565-1	1	
2	MOTOR SELHZ90-2M2 IMB34/2 2,7KW 230V	533651	1	
3	WASHER, 8.4 ZINC FLAT	F81054-1	11	
4	NUT, M8-8-B HEX NYLON ZINC LOCK	F81032-2	4	
5	BOLT, M8 X 30-8.8 SOCKET HEAD	F81002-31	4	
6	WASHER, 8.2 SPLIT LOCK ZINC	F81054-4	3	
7	SCREW, M8 X 20-8.8 HEX SOCKET HEAD CAP Z	F81002-30	3	
8	PULLEY, MULTI-GROOVE ALUMINIUM	533585	1	
9	SCREW M8X16 HSS W/FLAT POINT ZC 45H DIN	F81002-124	2	
10	BELT, 8 PJ 1355 MULTI-RIBBED	533679	1	

### 3.8 ECO Feed Drive 533638

533638\_001\_B  
533638\_MANUAL

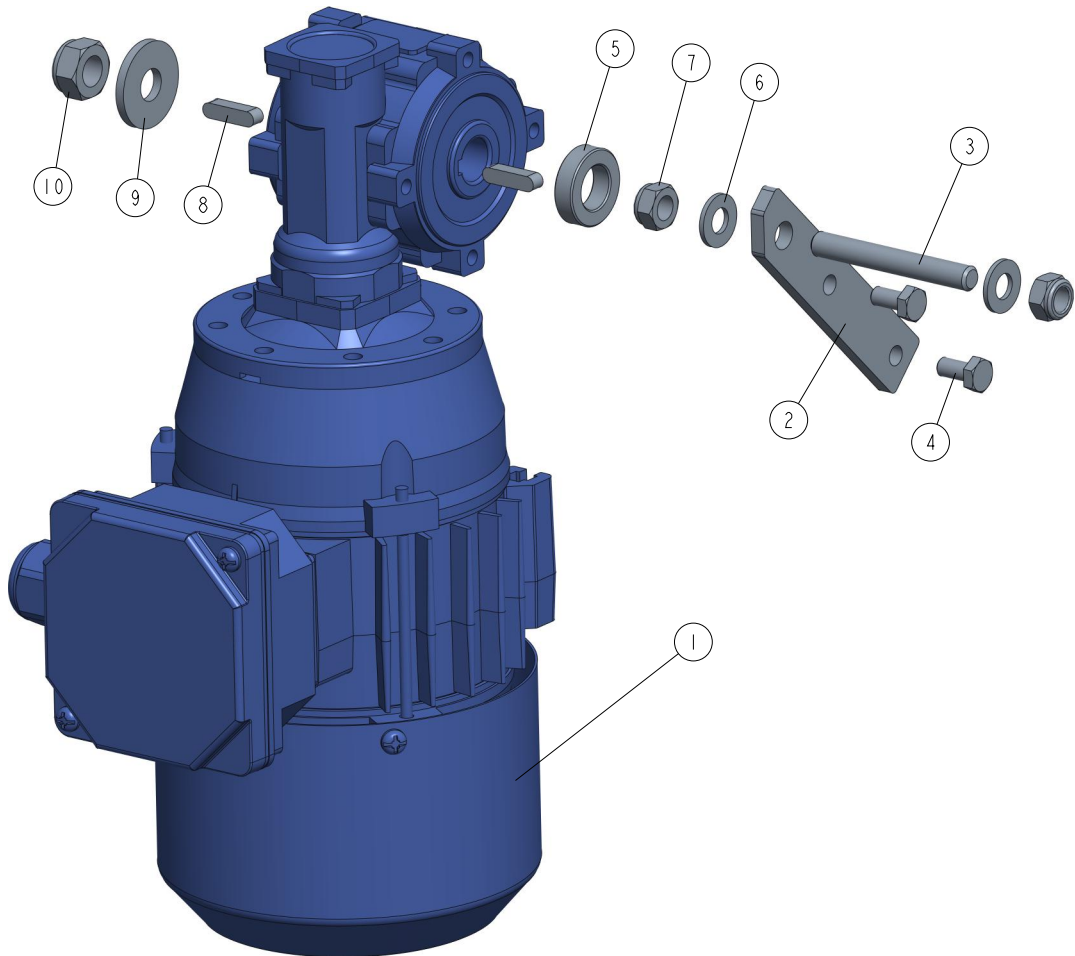

REF	DESCRIPTION (◆ indicates parts available in assemblies only)	PART #	QTY
-	DRIVE, MP200 ECO FEED	533638	1
1	MOTOREDUCTER, KC30/P30+SKH63-4B2/X <a href="#">See Section 3.9</a>	533639	1
2	ARM, TORQUE	533634-1	1
3	BOLT, M8	533635-1	1
4	BOLT M6X12 HH ZC FT 8.8 DIN 933	F81001-7	2
5	BUSHING, 14.3/25-7 ZINC-PLATED	533636-1	1
6	WASHER, 8.4 FLAT ZINC	F81054-1	2
7	NUT, M8 8 HEX NYLON ZINC LOCK	F81032-2	2
8	KEY, A5X5X20 PARALLEL	513320	2
9	WASHER, 10.5 SPECIAL FLAT ZINC	F81055-6	1
10	NUT, M10-8-B HEX NYLON ZINC LOCK	F81033-1	1

## 3.9 Motoreducer 533639

533639\_001  
533639

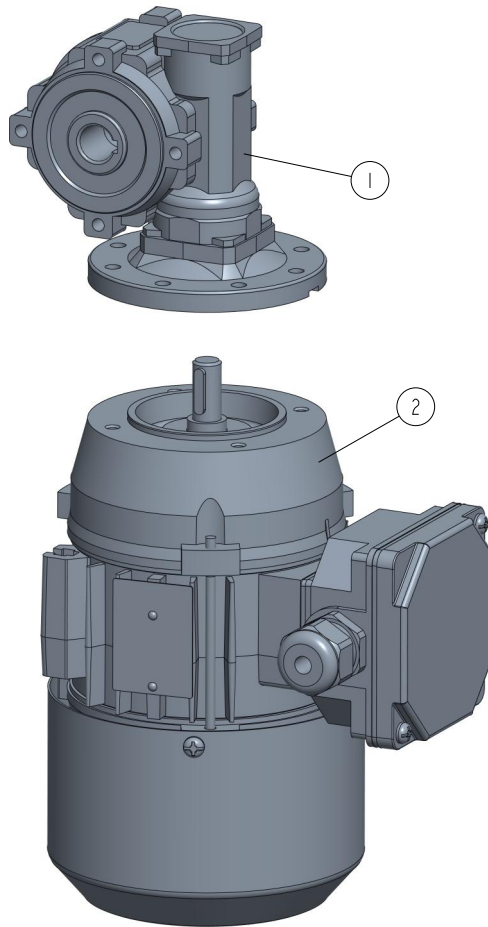

REF	DESCRIPTION (◆ indicates parts available in assemblies only)	PART #	QTY	
-	<b>MOTOREDUCER, KC30/P30+SKH63-4B2/X</b>	533639	1	
1	REDUCER, KC30/P30 90/11 V6	533637	1	
2	MOTOR, SKH63-4B2 (0.18KW; 1370 R.P.M.)	532802	1	

### 3.10 ECO Feed Drive 533638-6

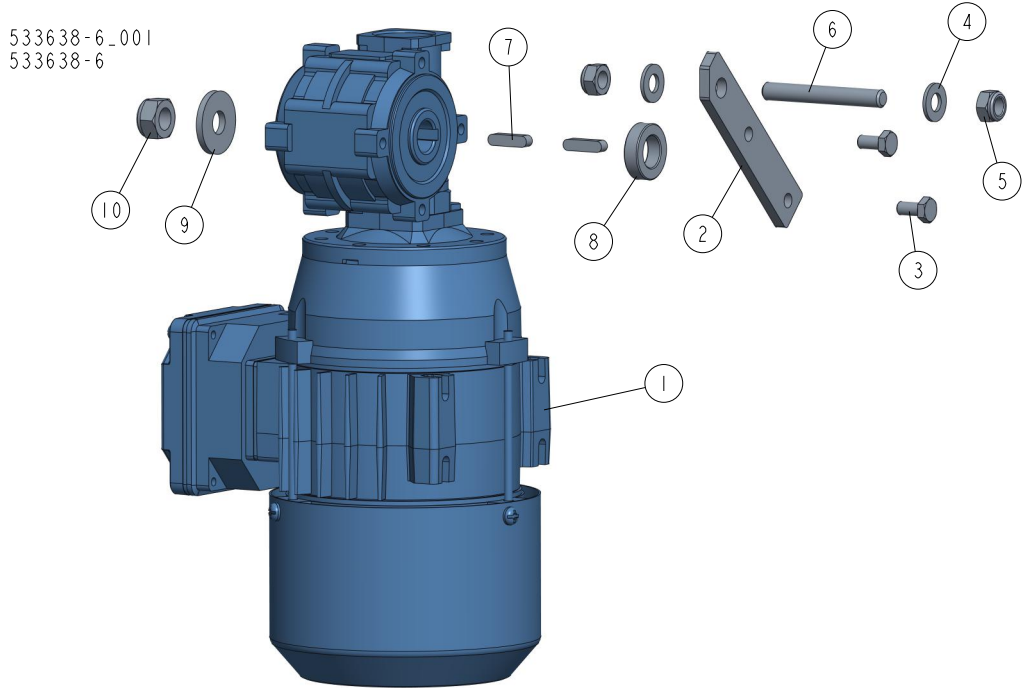

REF	DESCRIPTION (◆ indicates parts available in assemblies only)	PART #	QTY
-	<b>DRIVE, MP200 ECO FEED</b>	533638-6	1
1	MOTOREDUCER KC30/P30+SEMKH634C2/X <a href="#">See Section 3.11</a>	533654	1
2	ARM, TORQUE	533634-1	1
3	BOLT M6X12 8.8 FE/ZN5 PN-85/M-82105	F81001-7	2
4	WASHER, 8,4-FLAT ZINC	F81054-1	2
5	NUT, M8-8-B HEX NYLON ZINC LOCK	F81032-2	2
6	BOLT, M8	533635-1	1
7	KEY, A5X5X20 PARALLEL	513320	2
8	BUSHING, 14.3/25-7 ZINC-PLATED	533636-1	1
9	WASHER, 10.5 ZINC FLAT SPECIAL	F81055-6	1
10	NUT, M10-8-B NYLON HEX ZINC LOCK	F81033-1	1

## 3.11 Motoreducer 533654

533654\_001  
533654

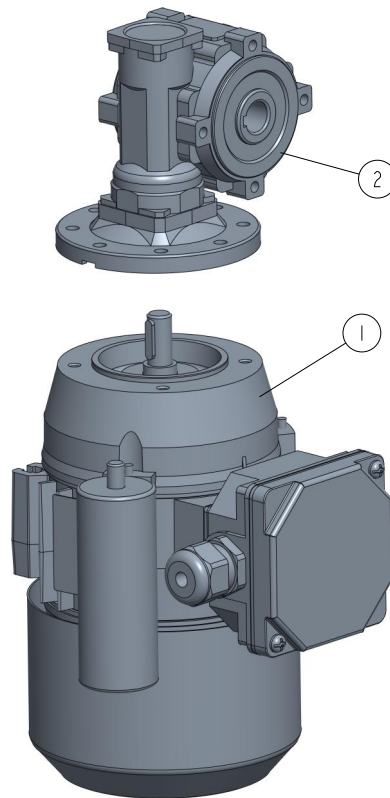

REF	DESCRIPTION (◆ indicates parts available in assemblies only)	PART #	QTY	
-	<b>MOTOREDUCER KC30/P30+SEMkh634C2/X</b>	533654	1	
1	MOTOR SEMKH 63-4C2/X 0.18KW	533656	1	
2	REDUCER, KC30/P30 90/11 V6	533637	1	



### 3.12 PRO Feed Drive 533650

533650\_002  
533650

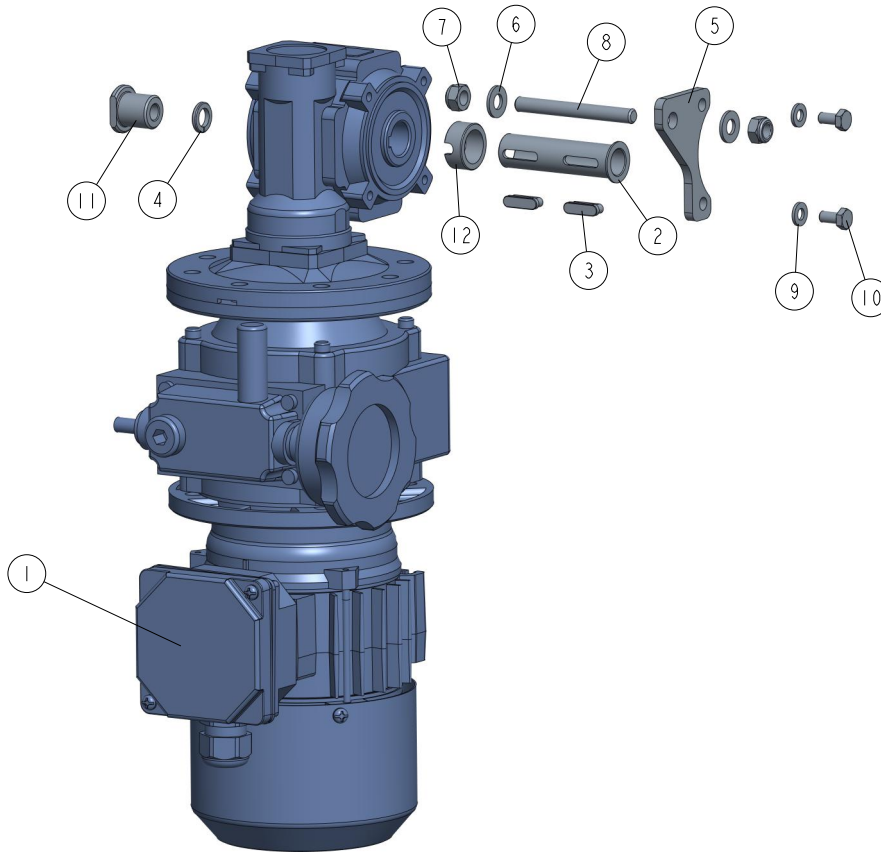

REF	DESCRIPTION (◆ indicates parts available in assemblies only)	PART #	QTY
-	<b>DRIVE, PRO FEED</b>	533650	1
1	REDUCER, PRO KC40/P15+NF003+SKH63-2C <a href="#">See Section 3.13</a>	533640	1
2	BUSHING, REDUCER	533731	1
3	KEY	533732	2
4	WASHER, 10.2 SPLIT LOCK ZINC	F81055-2	1
5	ARM, TORQUE	533734-1	1
6	WASHER, 8.4 ZINC FLAT	F81054-1	2
7	NUT, M8-8-B HEX NYLON ZINC LOCK	F81032-2	2
8	BOLT, M8	533635-1-6U	1
9	WASHER, 6.4 FLAT ZINC	F81053-1	2
10	BOLT, M6X12-8.8 HEX HEAD FULL THREAD ZIN	F81001-7	2
11	NUT, M10	533733-1-6U	1
12	BUSHING, REDUCER	541449	1

## 3.13 Reducer 533640

533640\_001  
533640

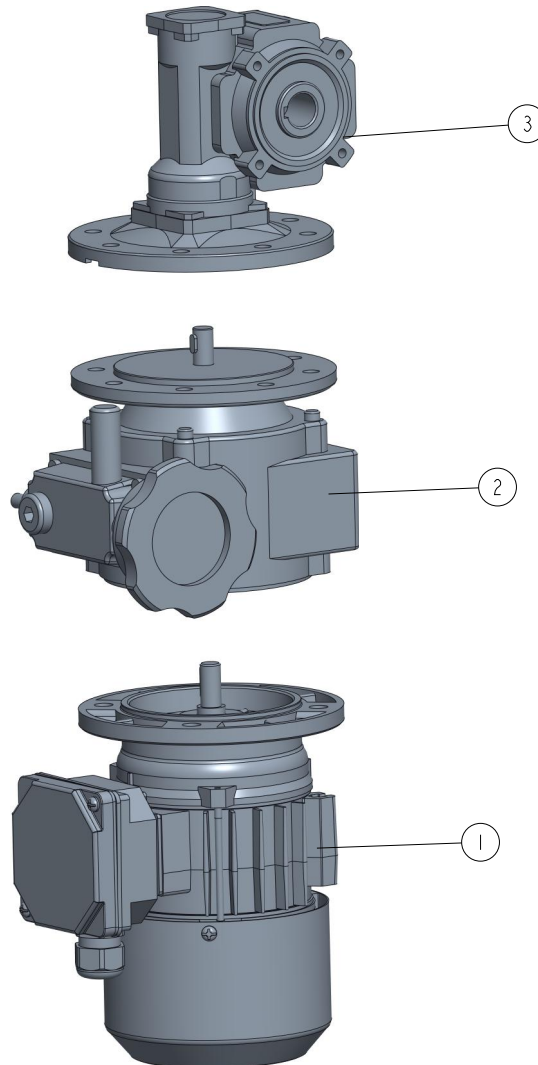

REF	DESCRIPTION (◆ indicates parts available in assemblies only)	PART #	QTY	
-	<b>REDUCER, PRO KC40/P15+NF003+SKH63-2C</b>	533640	1	
1	MOTOR SKH63-B (0.37 KW; 2800 REV/MIN)	533642	1	
2	SPEED VARIATOR NF003 140/11 V3	533643	1	
3	REDUCER KC40 P15 63 B5 V6 H18 3D	533641	1	

3.14 PRO Feed Drive 533650-6

533650\_002  
533650

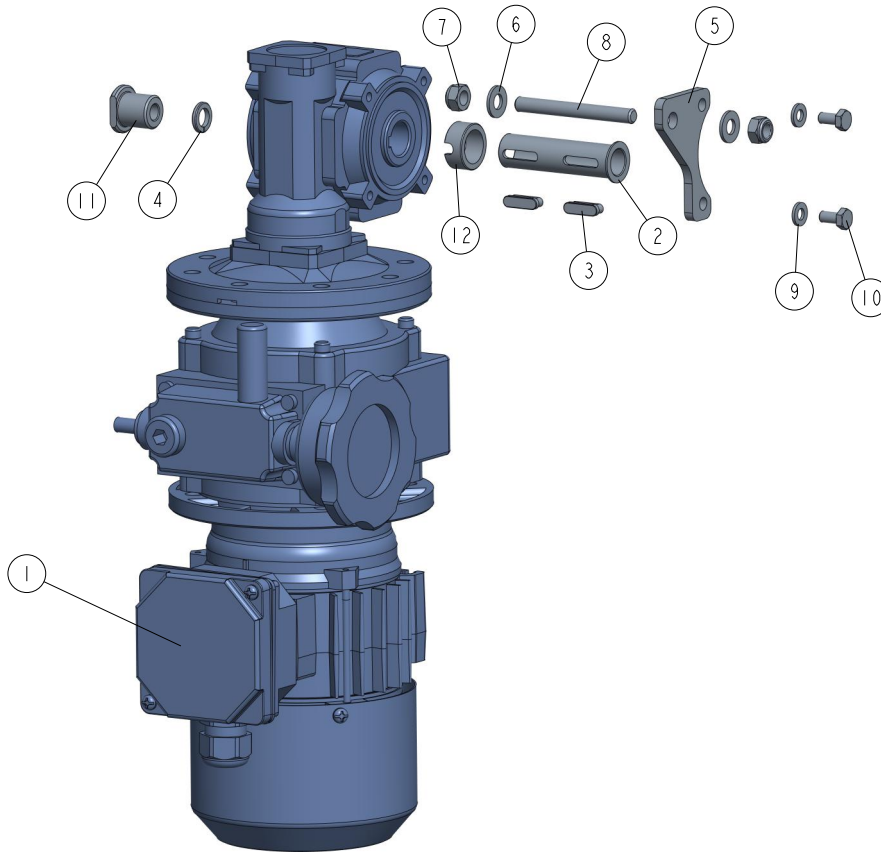

REF	DESCRIPTION (◆ indicates parts available in assemblies only)	PART #	QTY
-	<b>DRIVE, PRO FEED</b>	533650-6	1
1	MOTOREDUCER PRO KC40/P15+NF003+SEMkh71-2 <a href="#">See Section 3.15</a>	532807	1
2	BUSHING, REDUCER	533731	1
3	KEY	533732	2
4	WASHER, 10.2 SPLIT LOCK ZINC	F81055-2	1
5	ARM, TORQUE	533734-1	1
6	WASHER, 8.4 ZINC FLAT	F81054-1	2
7	NUT, M8-8-B HEX NYLON ZINC LOCK	F81032-2	2
8	BOLT, M8	533635-1-6U	1
9	WASHER, 6.4 FLAT ZINC	F81053-1	2
10	BOLT, M6X12-8.8 HEX HEAD FULL THREAD ZIN	F81001-7	2
11	NUT, M10	533733-1-6U	1
12	BUSHING, REDUCER	541449	1

## 3.15 Motoreducer 532807

532807\_001  
532807

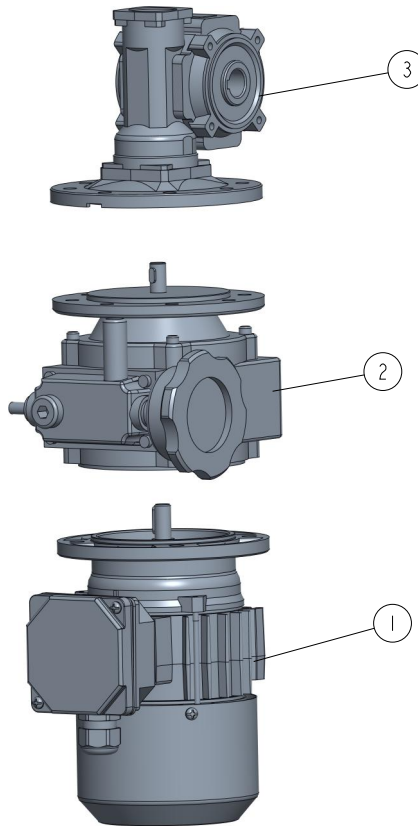

REF	DESCRIPTION (◆ indicates parts available in assemblies only)	PART #	QTY	
-	<b>MOTOREDUCER PRO KC40/P15+NF003+SEMKh71-2C/X</b>	532807	1	
1	MOTOR SKH63-B (0.37 KW; 2800 REV/MIN)	533642	1	
2	SPEED VARIATOR NF003 140/11 V3	533643	1	
3	REDUCER KC40 P15 63 B5 V6 H18 3D	533641	1	

## 3.16 Electric Box Mounting Bracket 533508

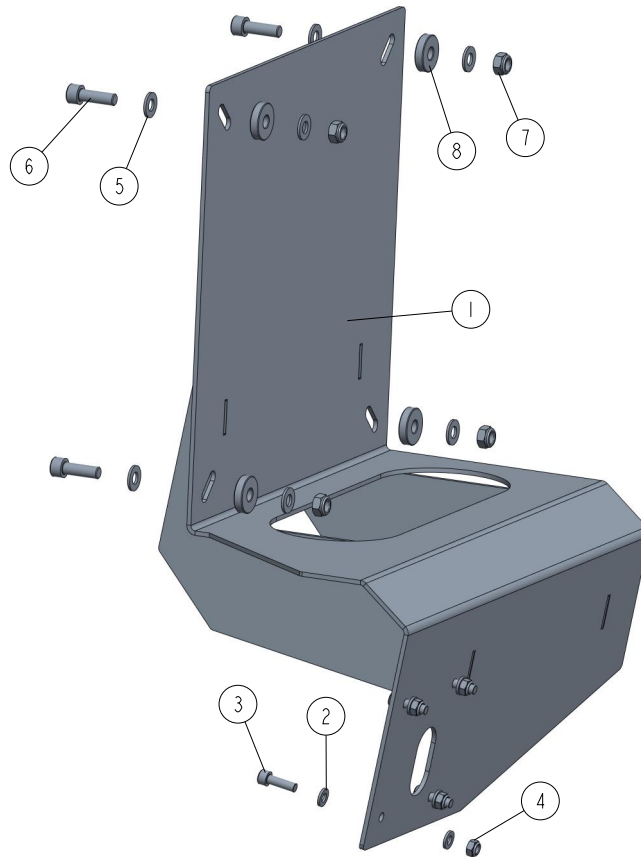
533508\_001\_A  
533508\_MANUAL

REF	DESCRIPTION (◆ indicates parts available in assemblies only)	PART #	QTY	
-	ELECTRIC BOX MOUNTING BRACKET COMPLETE	533508	1	
1	MOUNT ASSEMBLY, ELECTRIC BOX	533138-1	1	
2	WASHER, 6.4 FLAT ZINC	F81053-1	8	
3	SCREW, M6X20 8.8 HEX SOCKET HEAD CAP ZIN	F81001-22	4	
4	NUT, M6-8-B HEX NYLON ZINC LOCK	F81031-2	4	
5	WASHER, 8.4 ZINC FLAT	F81054-1	8	
6	SCREW, M8X25 -8.8 HEX SOCKET HEAD CAP	F81002-21	4	
7	NUT, M8-8-B HEX NYLON ZINC LOCK	F81032-2	4	
8	WASHER, 8.5/25-6 POLYAMIDE	523952	4	

## 3.17 Electrical Box 532820

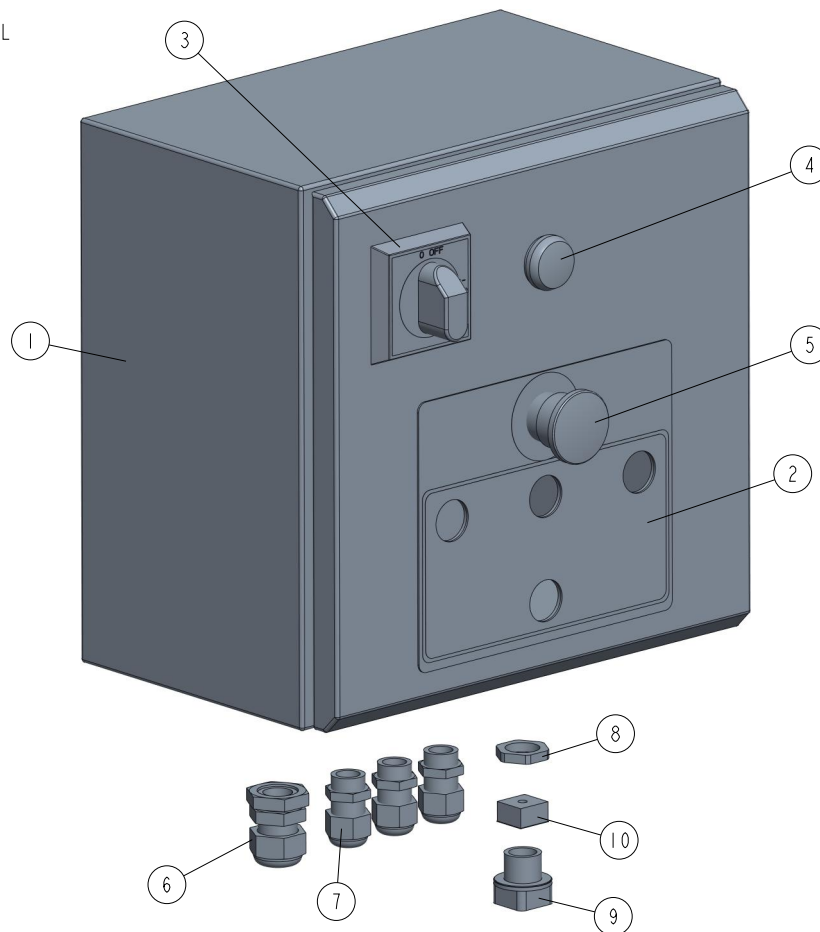
532820\_001  
532820\_MANUAL

REF	DESCRIPTION (◆ indicates parts available in assemblies only)	PART #	QTY
-	<b>BOX, ELECTRICAL - COMPLETE MP200EH 3X400</b>	532820	1
1	BOX, ELECTRICAL MP 200	533149	1
2	DECAL, ELECTRICAL BOX	533150	1
3	HANDLE, ABB SWITCH	088265-1	1
4	LIGHT, M22 LED 24V BLUE CONTROL	090448	1
5	SWITCH, XB2 BS542 EMERGENCY	086556	1
6	GLAND, DP16/H CABLE	F81096-7	1
7	GLAND, DW11/H CABLE	085388	3
8	NUT, M20X1.5 SPLIT CABLE GLAND	F81096-22	1
9	GLAND, QVT20 M20 GREY SPLIT CABLE	F81096-20	1
10	MODULE, QT5 GROMMET	F81096-23	1

---

## SECTION 4 MOTOR KITS MP200 UL AMERICAN VERSION

## 4.1 PRO Motor Kit 533131-2U

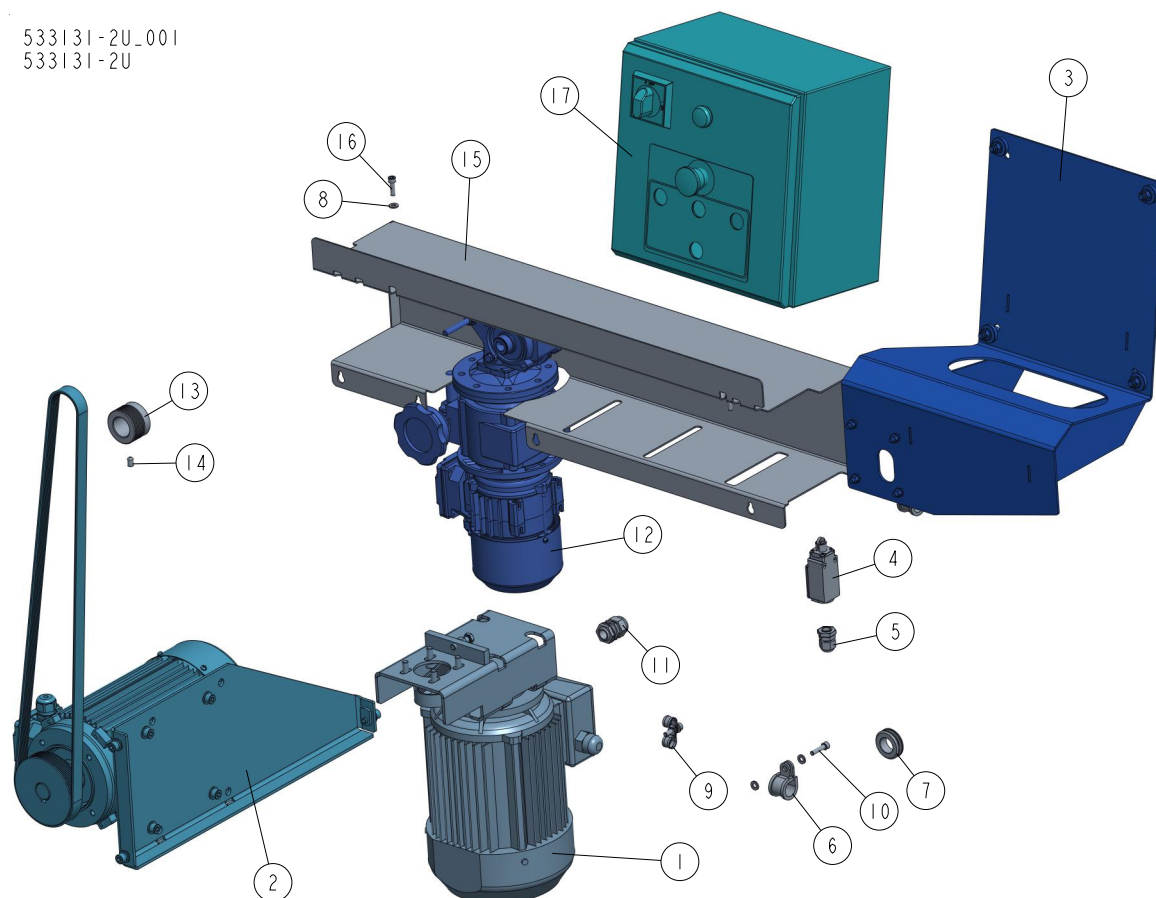
533131-2U\_001  
533131-2U

REF	DESCRIPTION (◆ indicates parts available in assemblies only)	PART #	QTY
-	<b>MOTOR KIT, PRO MP200EBU 3X230V UL</b>	533131-2U	1
1	SIDE CUTTER DRIVE UL <a href="#">See Section 4.7</a>	533647-U	1
2	DRIVE, HORIZONTAL CUTTER <a href="#">See Section 4.9</a>	533645-PU	1
3	ELECTRIC BOX MOUNTING BRACKET COMPLETE <a href="#">See Section 3.16</a>	533508	1
4	SWITCH, GLCB01C LIMIT	100910	1
5	GROMMET DP9/H	F81096-2	1
6	CLIP, RSGU 1.20/20 RETAINING	F81087-2	2
7	GROMMET, 22MM RUBBER	087400	1
8	WASHER, 6.4 ZINC FLAT	F81053-1	6
9	CLIP, RSGU 1.10/12W1 RETAINING	086861	4
10	SCREW, M6X25-8.8 HEX SOCKET HEAD CAP ZIN	F81001-41	3
11	GLAND, DP 20 HML CABLE	F81096-41	1
12	DRIVE, MP220 UL FEED <a href="#">See Section 4.12</a>	533650-U	1
13	PULLEY, MULTI-GROOVE SMALL ALUMINIUM	601602	1
14	SCREW M8X12 HSS W/CONE POINT ZC 45H DIN	F81002-105	1
15	FEED DRIVE GUARD ASSEMBLY	535161-1	1
16	SCREW, M6X20 8.8 HEX SOCKET HEAD CAP ZIN	F81001-22	2
17	BOX, ELECTRICAL - COMPLETE MP200EBU <a href="#">See Section 3.17</a>	532820-2U	1



## 4.2 PRO Motor Kit 533131-4U

533131-4U\_001  
533131-4U

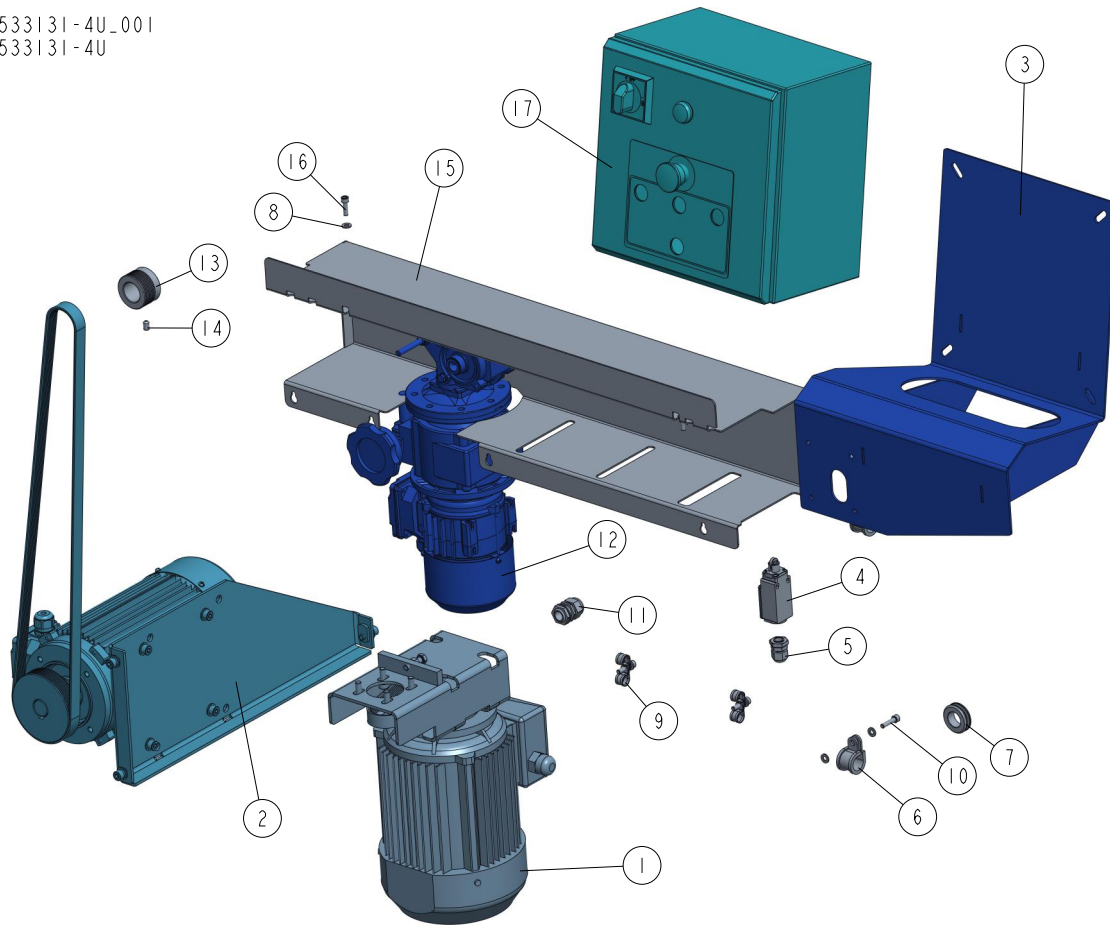

REF	DESCRIPTION (◆ indicates parts available in assemblies only)	PART #	QTY
-	<b>MOTOR KIT, PRO MP200ECU 3X460V UL</b>	533131-4U	1
1	SIDE CUTTER DRIVE UL <a href="#">See Section 4.7</a>	533647-U	1
2	DRIVE, HORIZONTAL CUTTER <a href="#">See Section 4.9</a>	533645-PU	1
3	MOUNT ASSEMBLY, ELECTRIC BOX	533138-1	1
4	SWITCH, GLCB01C LIMIT	100910	1
5	GROMMET DP9/H	F81096-2	1
6	CLIP, RSGU 1.20/20 RETAINING	F81087-2	2
7	GROMMET, 22MM RUBBER	087400	1
8	WASHER, 6.4 ZINC FLAT	F81053-1	6
9	CLIP, RSGU 1.10/12W1 RETAINING	086861	4
10	SCREW, M6X25-8.8 HEX SOCKET HEAD CAP ZIN	F81001-41	3
11	GLAND, DP 20 HML CABLE	F81096-41	1
12	DRIVE, MP220 UL FEED <a href="#">See Section 4.12</a>	533650-U	1
13	PULLEY, MULTI-GROOVE SMALL ALUMINIUM	601602	1
14	SCREW M8X12 HSS W/CONE POINT ZC 45H DIN	F81002-105	1
15	FEED DRIVE GUARD ASSEMBLY	535161-1	1
16	SCREW, M6X20 8.8 HEX SOCKET HEAD CAP ZIN	F81001-22	2
17	BOX, ELECTRICAL - COMPLETE MP200ECU <a href="#">See Section 3.17</a>	532820-4U	1

## 4.3 PRO Motor Kit 533131-6U

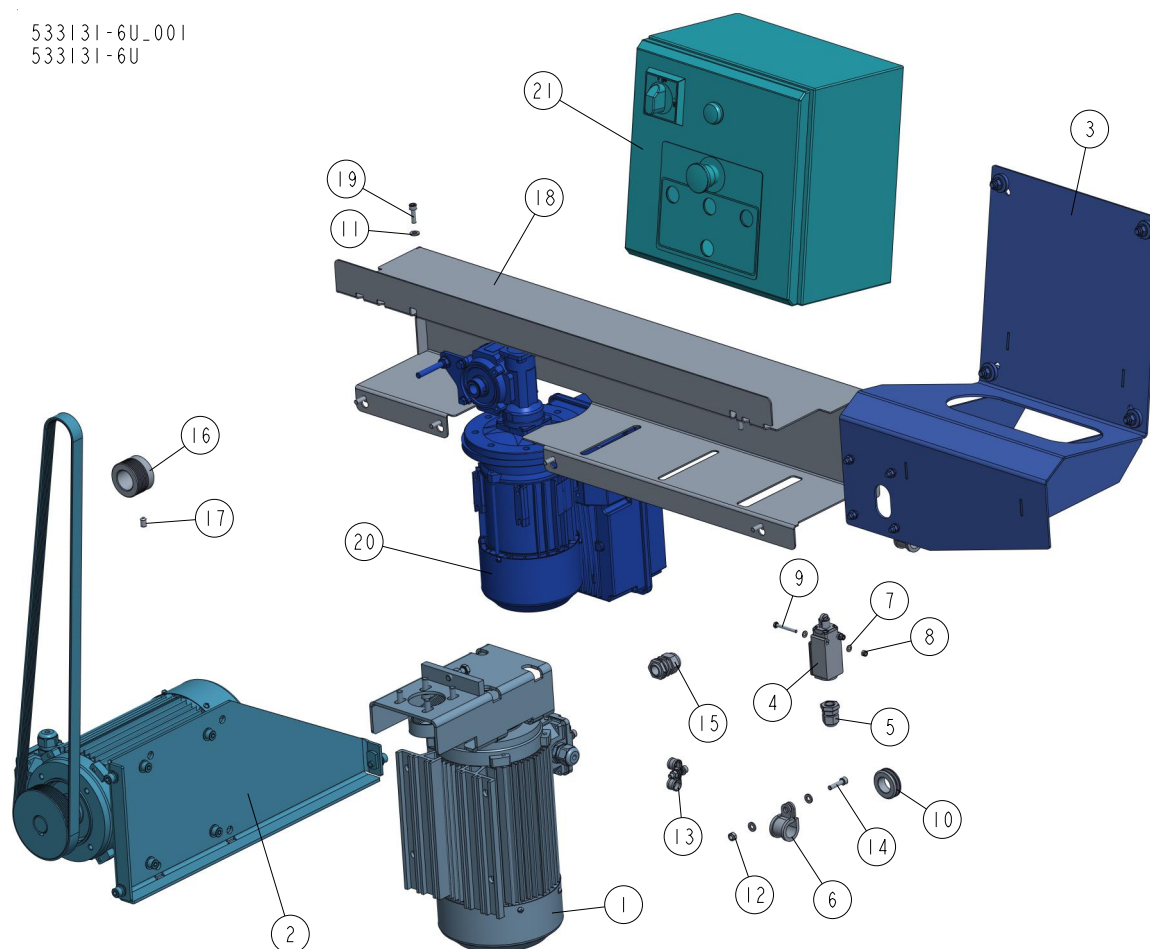
533131-6U\_001  
533131-6U

REF	DESCRIPTION (◆ indicates parts available in assemblies only)	PART #	QTY
-	<b>MOTOR KIT, PRO MP200EAU 1X230V UL</b>	533131-6U	1
1	SIDE CUTTER DRIVE 230V UL <a href="#">See Section 4.8</a>	533647-6U	1
2	DRIVE, HORIZONTAL CUTTER 230V UL <a href="#">See Section 4.10</a>	533645-6U	1
3	ELECTRIC BOX MOUNTING BRACKET COMPLETE <a href="#">See Section 3.16</a>	533508	1
4	SWITCH, GLCB01C LIMIT	100910	1
5	GROMMET DP9/H	F81096-2	1
6	CLIP, RSGU 1.20/20 RETAINING	F81087-2	2
7	WASHER, 4.3 ZINC FLAT	F81051-2	4
8	NUT, M4-B HEX NYLON ZINC LOCK	F81029-1	2
9	BOLT M4X35 HH ZC FT 8.8 DIN 933	F81011-7	2
10	GROMMET, 22MM RUBBER	087400	1
11	WASHER, 6.4 ZINC FLAT	F81053-1	12
12	NUT, M6-8-B HEX NYLON ZINC LOCK	F81031-2	3
13	CLIP, RSGU 1.10/12W1 RETAINING	086861	4
14	SCREW, M6X25-8.8 HEX SOCKET HEAD CAP ZIN	F81001-41	3
15	GLAND, DP 20 HML CABLE	F81096-41	1
16	PULLEY, MULTI-GROOVE SMALL ALUMINIUM	601602	1
17	SCREW M8X12 HSS W/CONE POINT ZC 45H DIN	F81002-105	1

REF	DESCRIPTION (◆ indicates parts available in assemblies only)	PART #	QTY	
18	FEED DRIVE GUARD ASSEMBLY	535161-1	1	
19	SCREW, M6X20 8.8 HEX SOCKET HEAD CAP ZIN	F81001-22	6	
20	PRO FEED DRIVE <a href="#">See Section 4.14</a>	533650-6U	1	
21	BOX, ELECTRICAL - COMPLETE MP200EAU <a href="#">See Section 3.17</a>	532820-6U	1	

## 4.4 ECO Motor Kit 533132-2U

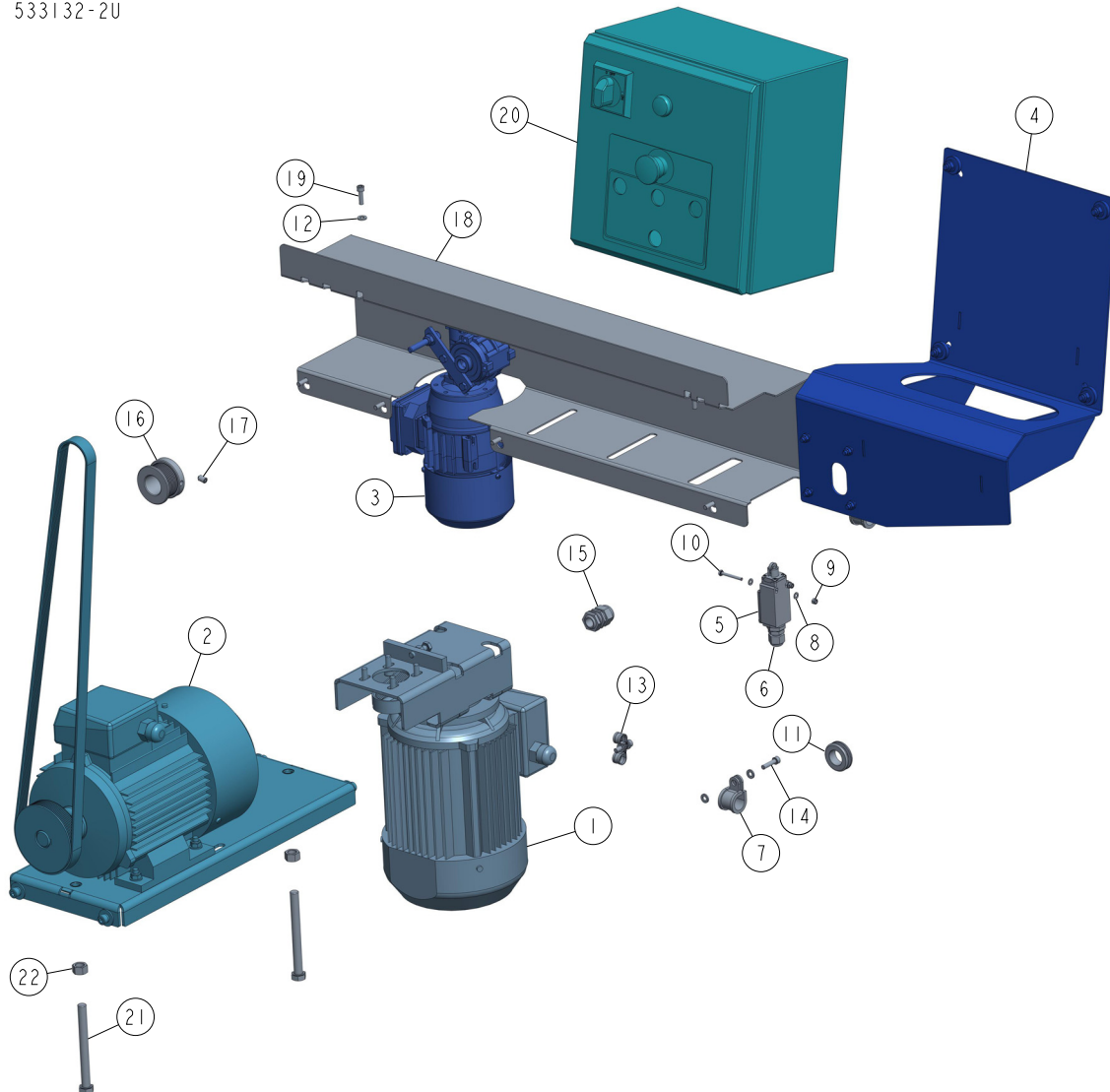
533132-2U\_001  
533132-2U

REF	DESCRIPTION (◆ indicates parts available in assemblies only)	PART #	QTY
-	<b>MOTOR KIT, ECO MP200EBU 3X230V UL</b>	533132-2U	1
1	SIDE CUTTER DRIVE UL <a href="#">See Section 4.7</a>	533647-U	1
2	DRIVE, HORIZONTAL CUTTER <a href="#">See Section 4.11</a>	533645-U	1
3	DRIVE, ECO FEED <a href="#">See Section 4.16</a>	533638-U	1
4	ELECTRIC BOX MOUNTING BRACKET COMPLETE <a href="#">See Section 3.16</a>	533508	1
5	SWITCH, GLCB01C LIMIT	100910	1
6	GROMMET DP9/H	F81096-2	1
7	CLIP, RSGU 1.20/20 RETAINING	F81087-2	2
8	WASHER, 4.3 ZINC FLAT	F81051-2	4
9	NUT, M4-B HEX NYLON ZINC LOCK	F81029-1	2
10	BOLT M4X35 HH ZC FT 8.8 DIN 933	F81011-7	2
11	GROMMET, 22MM RUBBER	087400	1
12	WASHER, 6.4 ZINC FLAT	F81053-1	12
13	CLIP, RSGU 1.10/12W1 RETAINING	086861	4

REF	DESCRIPTION (◆ indicates parts available in assemblies only)	PART #	QTY	
14	SCREW, M6X25-8.8 HEX SOCKET HEAD CAP ZIN	F81001-41	3	
15	GLAND, DP 20 HML CABLE	F81096-41	1	
16	PULLEY, MULTI-GROOVE SMALL ALUMINIUM	601602	1	
17	SCREW M8X12 HSS W/CONE POINT ZC 45H DIN	F81002-105	1	
18	GUARD, FEED DRIVE	533666-1	1	
19	SCREW, M6X20 8.8 HEX SOCKET HEAD CAP ZIN	F81001-22	6	
20	BOX, ELECTRICAL - COMPLETE MP200EBU <a href="#">See Section 3.17</a>	532820-2U	1	
21	NUT, M12, HEXAGON, GRADE 5.8, ZINC	F81034-1	2	
22	BOLT, M12X120-8.8 HEX HEAD ZINC, BOLT M12X120 8.8 FE/ZN5	F81004-38	2	

## 4.5 ECO Motor Kit 533132-4U

533132-4U\_001  
533132-4U

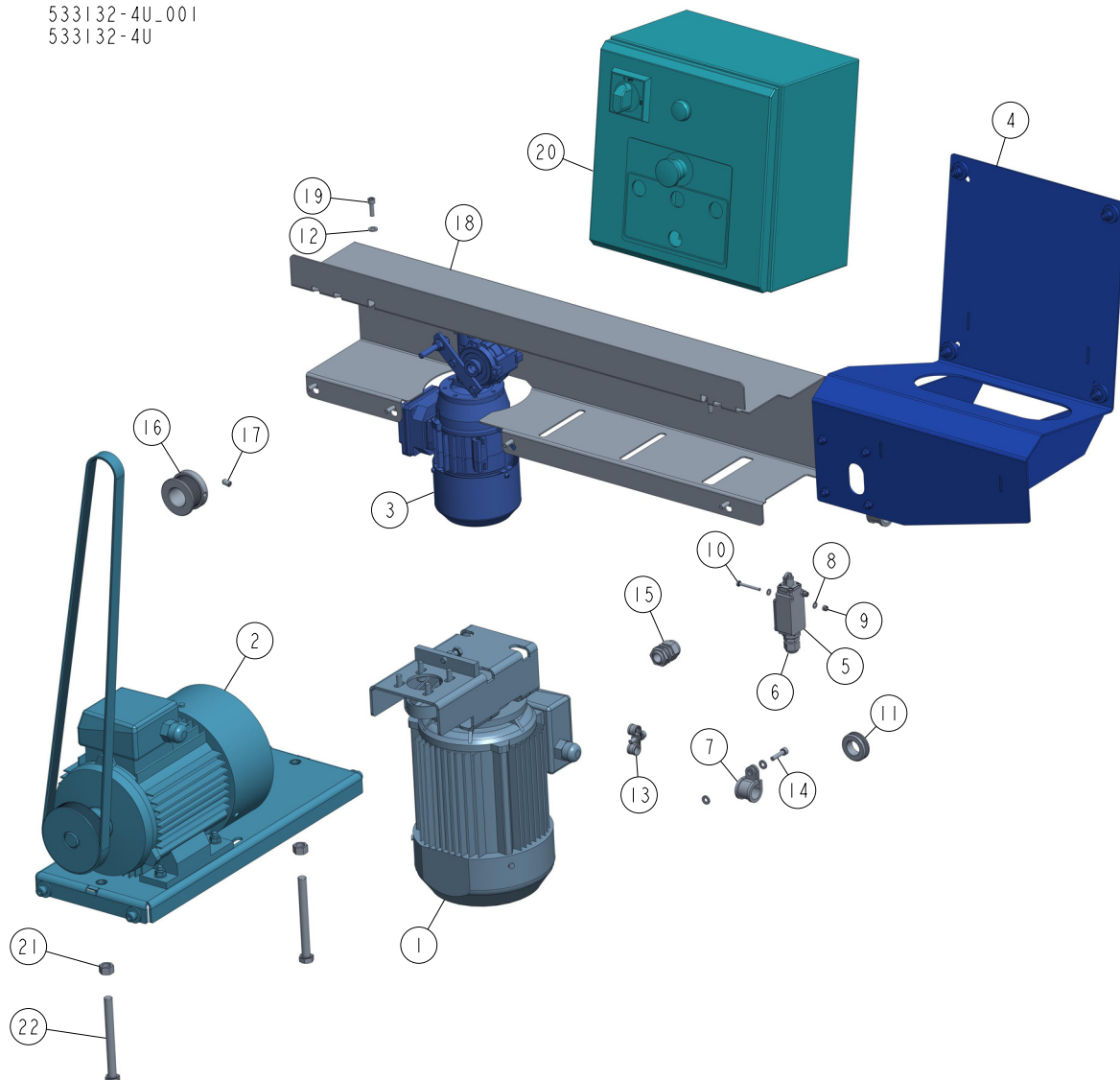

REF	DESCRIPTION (◆ indicates parts available in assemblies only)	PART #	QTY
-	<b>MOTOR KIT, ECO MP200ECU 3X460V UL</b>	533132-4U	1
1	SIDE CUTTER DRIVE UL <a href="#">See Section 4.7</a>	533647-U	1
2	DRIVE, HORIZONTAL CUTTER <a href="#">See Section 4.11</a>	533645-U	1
3	DRIVE, ECO FEED <a href="#">See Section 4.16</a>	533638-U	1
4	ELECTRIC BOX MOUNTING BRACKET COMPLETE <a href="#">See Section 3.16</a>	533508	1
5	SWITCH, GLCB01C LIMIT	100910	1
6	GROMMET DP9/H	F81096-2	1
7	CLIP, RSGU 1.20/20 RETAINING	F81087-2	2
8	WASHER, 4.3 ZINC FLAT	F81051-2	4
9	NUT, M4-B HEX NYLON ZINC LOCK	F81029-1	2
10	BOLT M4X35 HH ZC FT 8.8 DIN 933	F81011-7	2
11	GROMMET, 22MM RUBBER	087400	1
12	WASHER, 6.4 ZINC FLAT	F81053-1	12

REF	DESCRIPTION (◆ indicates parts available in assemblies only)	PART #	QTY	
13	CLIP, RSGU 1.10/12W1 RETAINING	086861	4	
14	SCREW, M6X25-8.8 HEX SOCKET HEAD CAP ZIN	F81001-41	3	
15	GLAND, DP 20 HML CABLE	F81096-41	1	
16	PULLEY, MULTI-GROOVE SMALL ALUMINIUM	601602	1	
17	SCREW M8X12 HSS W/CONE POINT ZC 45H DIN	F81002-105	1	
18	GUARD, FEED DRIVE	533666-1	1	
19	SCREW, M6X20 8.8 HEX SOCKET HEAD CAP ZIN	F81001-22	6	
20	BOX, ELECTRICAL - COMPLETE MP200ECU <a href="#">See Section 3.17</a>	532820-4U	1	
21	NUT, M12, HEXAGON, GRADE 5.8, ZINC	F81034-1	2	
22	BOLT, M12X120-8.8 HEX HEAD ZINC, BOLT M12X120 8.8 FE/ZN5	F81004-38	2	

## 4.6 ECO Motor Kit 533132-6U

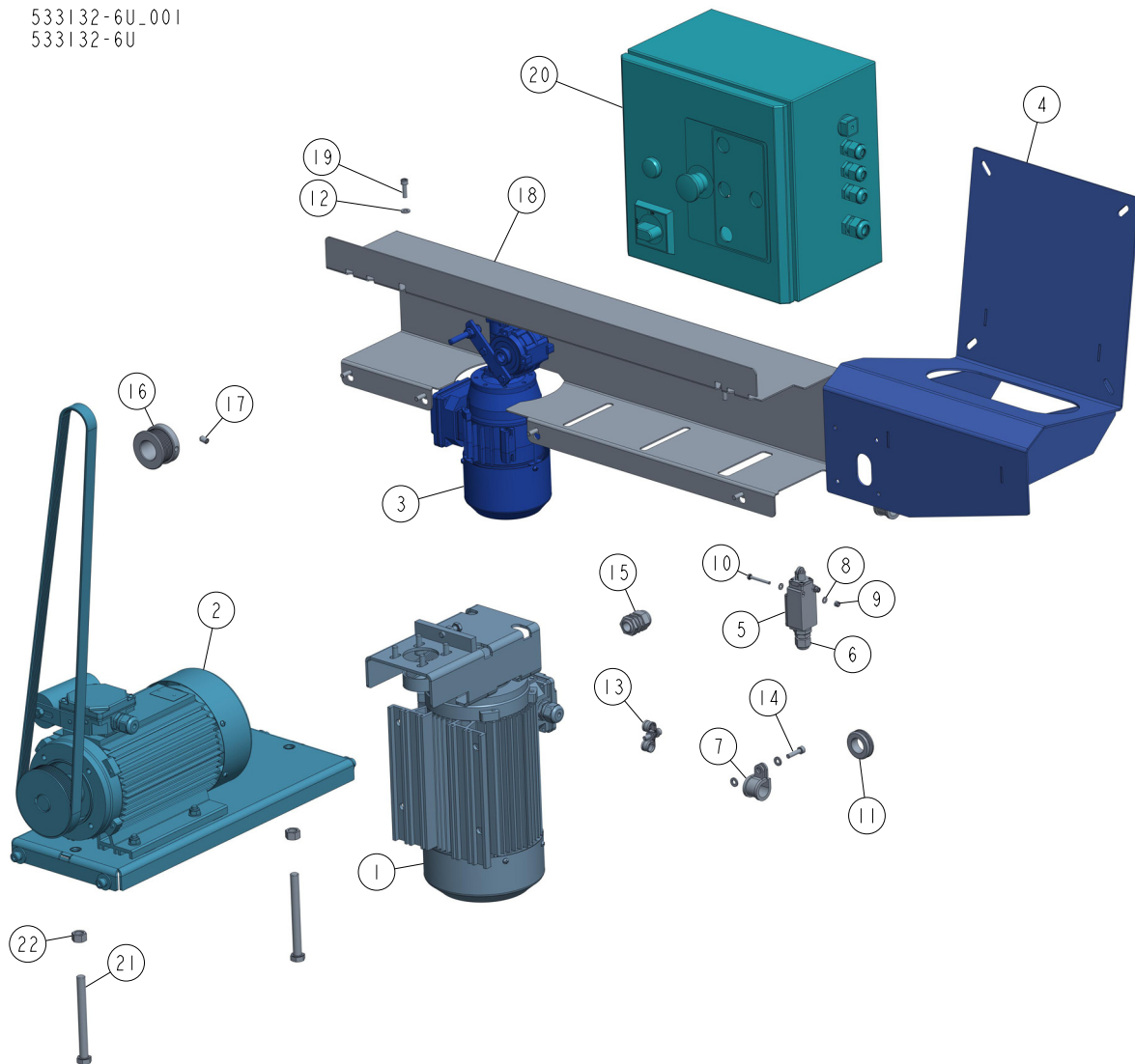
533132-6U\_001  
533132-6U

REF	DESCRIPTION (◆ indicates parts available in assemblies only)	PART #	QTY
-	<b>MOTOR KIT, ECO MP200EAU 1X230V UL</b>	533132-6U	1
1	SIDE CUTTER DRIVE 230V UL <a href="#">See Section 4.8</a>	533647-6U	1
2	DRIVE, HORIZONTAL CUTTER 230V UL <a href="#">See Section 4.10</a>	533645-6U	1
3	DRIVE, ECO FEED <a href="#">See Section 4.18</a>	533638-6U	1
4	MOUNT ASSEMBLY, ELECTRIC BOX	533138-1	1
5	SWITCH, GLCB01C LIMIT	100910	1
6	GROMMET DP9/H	F81096-2	1
7	CLIP, RSGU 1.20/20 RETAINING	F81087-2	2
8	WASHER, 4.3 ZINC FLAT	F81051-2	4
9	NUT, M4-B HEX NYLON ZINC LOCK	F81029-1	2
10	BOLT M4X35 HH ZC FT 8.8 DIN 933	F81011-7	2
11	GROMMET, 22MM RUBBER	087400	1
12	WASHER, 6.4 ZINC FLAT	F81053-1	12
13	CLIP, RSGU 1.10/12W1 RETAINING	086861	4



REF	DESCRIPTION (◆ indicates parts available in assemblies only)	PART #	QTY	
14	SCREW, M6X25-8.8 HEX SOCKET HEAD CAP ZIN	F81001-41	3	
15	GLAND, DP 20 HML CABLE	F81096-41	1	
16	PULLEY, MULTI-GROOVE SMALL ALUMINIUM	601602	1	
17	SCREW M8X12 HSS W/CONE POINT ZC 45H DIN	F81002-105	1	
18	GUARD, FEED DRIVE	533666-1	1	
19	SCREW, M6X20 8.8 HEX SOCKET HEAD CAP ZIN	F81001-22	6	
20	BOX, ELECTRICAL - COMPLETE MP200EAU <a href="#">See Section 3.17</a>	532820-6U	1	
21	NUT, M12, HEXAGON, GRADE 5.8, ZINC	F81034-1	2	
22	BOLT, M12X120-8.8 HEX HEAD ZINC, BOLT M12X120 8.8 FE/ZN5	F81004-38	2	

## 4.7 Side Cutter Drive UL 533647-U

533647-U\_001  
533647-U

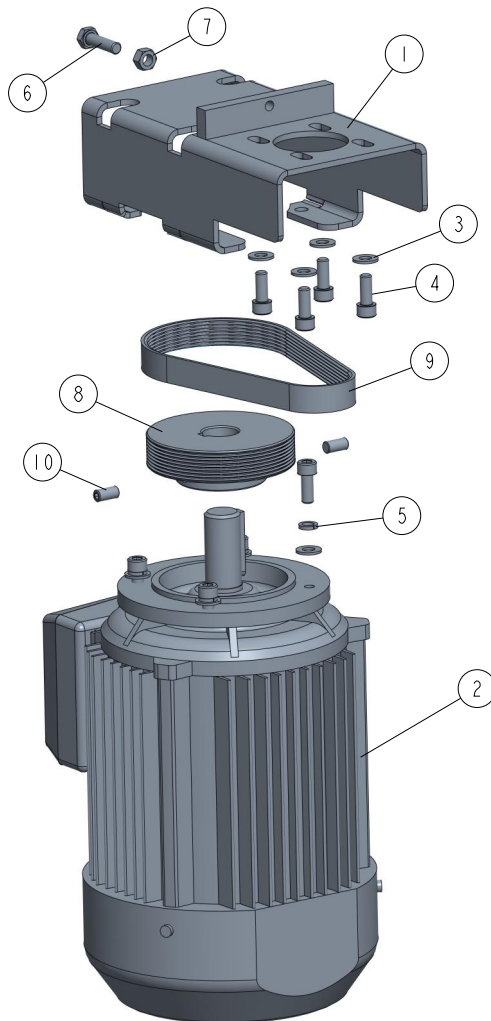

REF	DESCRIPTION (◆ indicates parts available in assemblies only)	PART #	QTY
-	<b>SIDE CUTTER DRIVE UL</b>	533647-U	1
1	PLATE WELDMENT, MP200 MOTOR PAINTED MOUN	533649-1	1
2	MOTOR, INDUKTA 3SIEK90L2A 3KW IMV19 UL	537385-UL	1
3	WASHER, 8,4-FLAT ZINC	F81054-1	8
4	SCREW, M8X20-8.8 HEX SOCKET HEAD CAP ZIN	F81002-30	8
5	WASHER, 8.2 SPLIT LOCK	F81054-4	4
6	BOLT, M8X30 8.8 HEX HEAD FULL THREAD ZIN	F81002-7	1
7	NUT M8 ZC 8 DIN 934	F81032-1	1
8	PULLEY, MULTI-GROOVE ALUMINIUM	533585	1
9	BELT, 8 PJ 457 MULTI-RIBBED	533680	1
10	SCREW M8X16 HSS W/FLAT POINT ZC 45H DIN	F81002-124	2

## 4.8 Side Cutter Drive 533647-6U

533647-6U\_001  
533647-6U

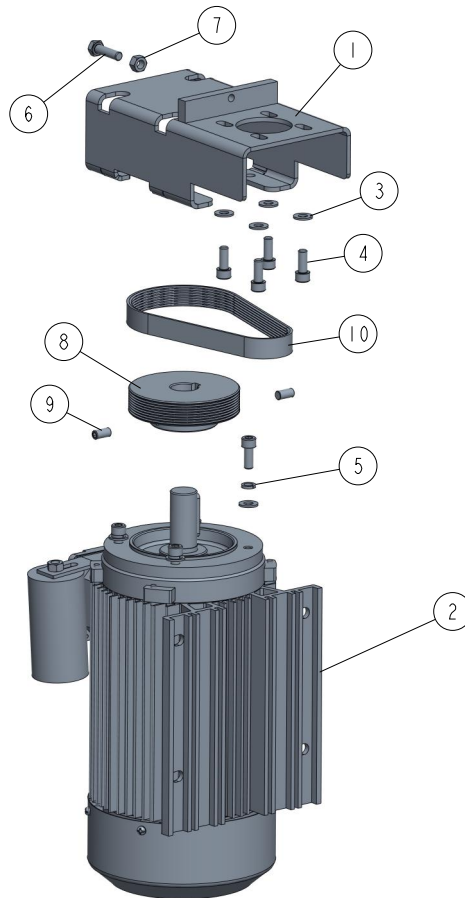

REF	DESCRIPTION (◆ indicates parts available in assemblies only)	PART #	QTY	
-	<b>SIDE CUTTER DRIVE 230V UL</b>	533647-6U	1	
1	PLATE WELDMENT, MP200 MOTOR PAINTED MOU	533649-1	1	
2	MOTOR, SELHR90-2M2 IMB34/2 2,7KW 230V UL	533651-UL	1	
3	WASHER, 8.4 FLAT ZINC	F81054-1	8	
4	BOLT, M8 X 20-8.8 SOCKET HEAD	F81002-30	8	
5	WASHER, 8.2 SPLIT LOCK	F81054-4	4	
6	BOLT, M8X30 8.8 HEX HEAD FULL THREAD ZIN	F81002-7	1	
7	NUT, M8-8-B HEX ZINC	F81032-1	1	
8	PULLEY, MULTI-GROOVE ALUMINIUM	533585	1	
9	SCREW M8X16 HSS W/FLAT POINT ZC 45H DIN	F81002-124	2	
10	BELT, 8 PJ 457 MULTI-RIBBED	533680	1	

## 4.9 Horizontal Cutter PRO Drive 533645-PU

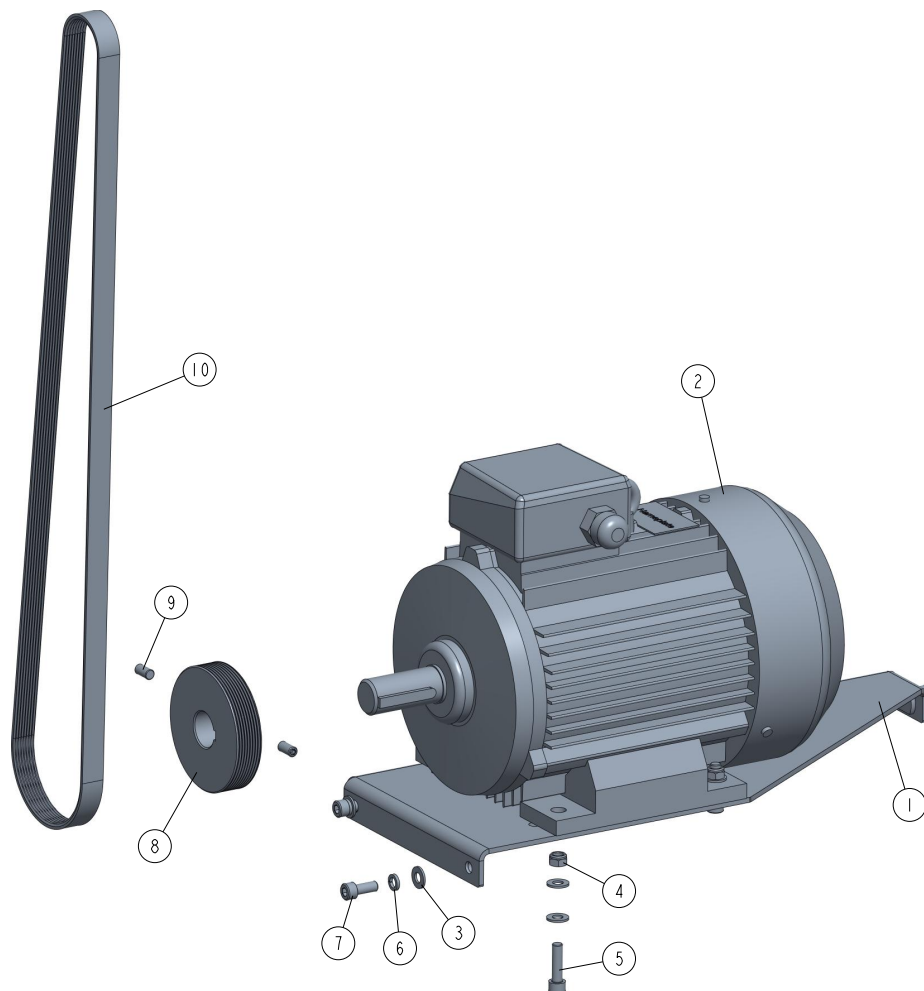
533645-P\_001  
533645-P

REF	DESCRIPTION (◆ indicates parts available in assemblies only)	PART #	QTY	
-	<b>DRIVE, HORIZONTAL CUTTER PRO</b>	533645-PU	1	
1	PLATE WELDMENT, ENGINE MOUNT	533565-1	1	
2	MOTOR, INDUKTA 3SIE100L2A 4KW IMB3 UL	537387-UL	1	
3	WASHER, 8.4 ZINC FLAT	F81054-1	11	
4	NUT, M8-8-B HEX NYLON ZINC LOCK	F81032-2	4	
5	BOLT, M8 X 30-8.8 SOCKET HEAD	F81002-31	4	
6	WASHER, 8.2 SPLIT LOCK ZINC	F81054-4	3	
7	SCREW, M8 X 20-8.8 HEX SOCKET HEAD CAP Z	F81002-30	3	
8	SHEAVE, MP200 PRO MULTI-GROOVE	533585-P	1	
9	SCREW M8X16 HSS W/FLAT POINT ZC 45H DIN	F81002-124	2	
10	BELT, 8 PJ 1355 MULTI-RIBBED	533679	1	

## 4.10 Horizontal Cutter Drive 533645-6U

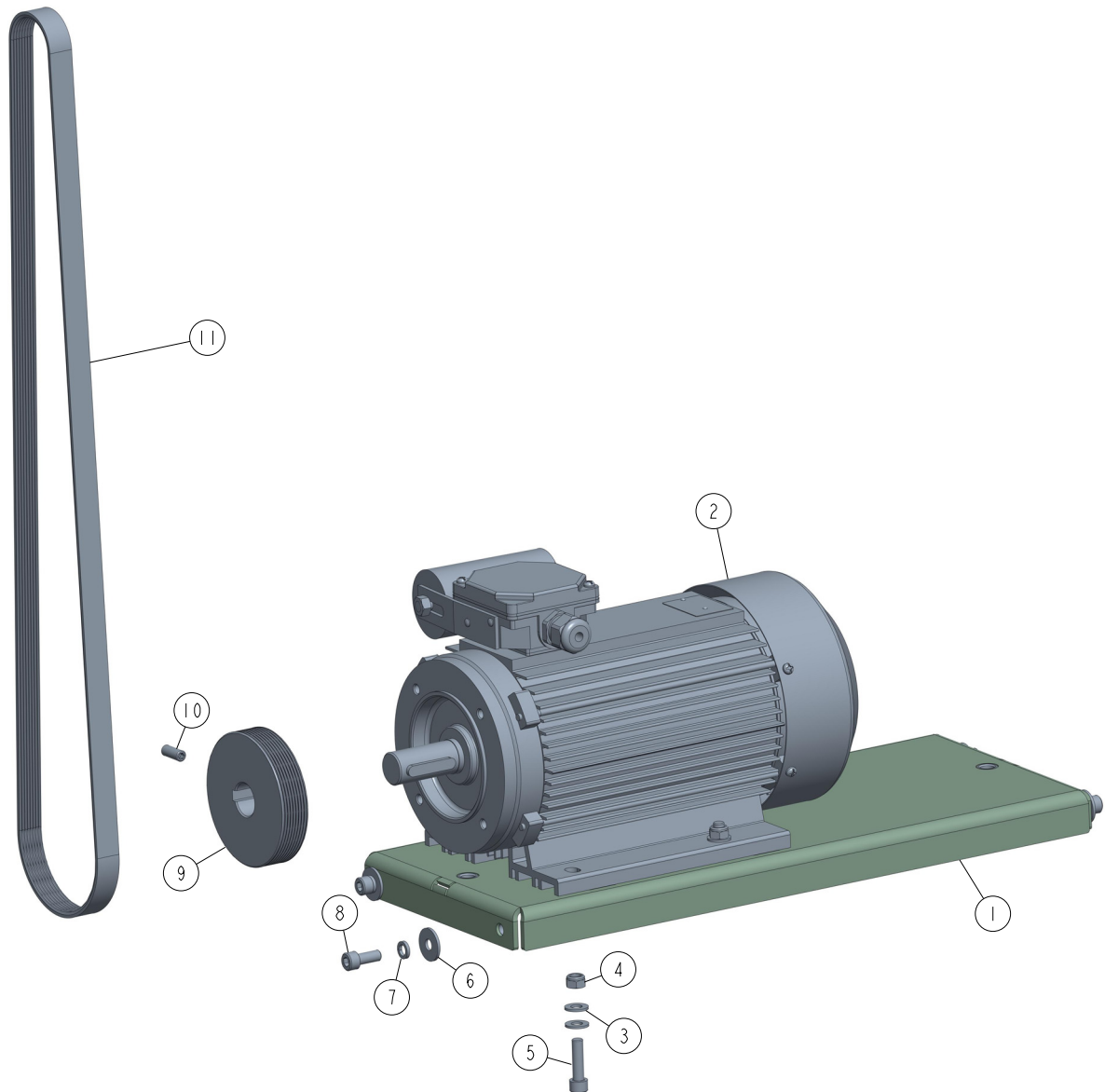
533645-6U\_001  
533645-6U

REF	DESCRIPTION (◆ indicates parts available in assemblies only)	PART #	QTY
-	<b>DRIVE, HORIZONTAL CUTTER 230V UL</b>	533645-6U	1
1	MOTOR PLATE WELDED / PAINT	534200-1	1
2	MOTOR, SELHR90-2M2 IMB34/2 2,7KW 230V	533651-UL	1
3	WASHER, 8.4 FLAT ZINC	F81054-1	8
4	NUT, M8-8-B HEX NYLON ZINC LOCK	F81032-2	4
5	SCREW, M8X30-8.8 HEX SOCKET HEAD CAP ZIN	F81002-31	4
6	WASHER, 8.5 SPLIT LOCK ZINC	F81054-11	4
7	WASHER 8,2 FE/ZN9	F81054-4	4
8	BOLT, M8 X 20-8.8 SOCKET HEAD	F81002-30	4
9	PULLEY, MULTI-GROOVE ALUMINIUM	533585	1
10	SCREW M8X20 HSS W/FLAT POINT ZC 45H DIN	F81002-103	1
11	BELT, 8 PJ 1355 MULTI-RIBBED	533679	1

## 4.11 Horizontal Cutter ECO Drive 533645-U

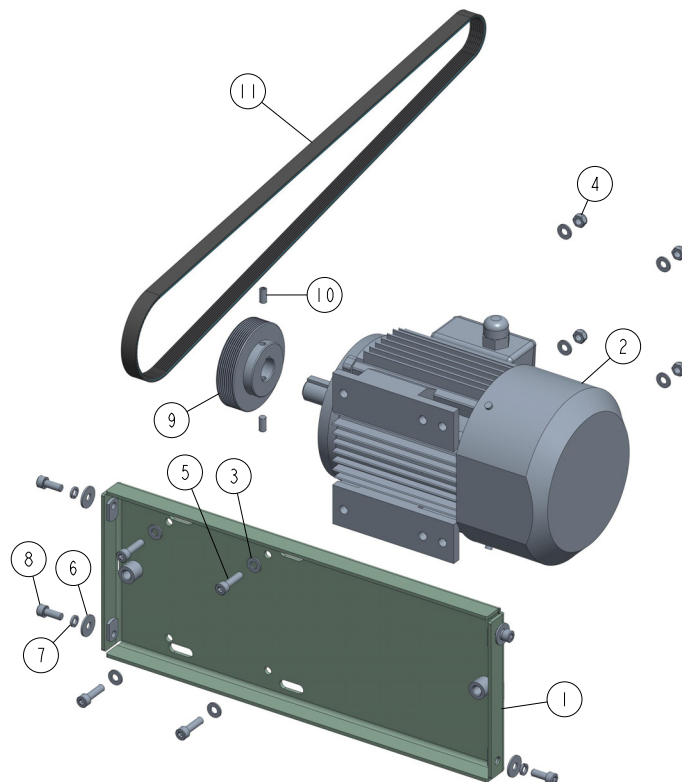
533645\_001\_C  
533645\_MANUAL

REF	DESCRIPTION (◆ indicates parts available in assemblies only)	PART #	QTY	
-	<b>DRIVE, HORIZONTAL CUTTER ECO</b>	533645-U	1	
1	PLATE WELDMENT, ENGINE MOUNT	533565-1	1	
2	MOTOR 3SIE90L2A, 3KW IMB3 UL, 3480 R.P.M	537386-UL	1	
3	WASHER, 8.4 ZINC FLAT	F81054-1	11	
4	NUT, M8-8-B HEX NYLON ZINC LOCK	F81032-2	4	
5	BOLT, M8 X 30-8.8 SOCKET HEAD	F81002-31	4	
6	WASHER, 8.2 SPLIT LOCK ZINC	F81054-4	3	
7	SCREW, M8 X 20-8.8 HEX SOCKET HEAD CAP Z	F81002-30	3	
8	PULLEY, MULTI-GROOVE ALUMINIUM	533585	1	
9	SCREW M8X16 HSS W/FLAT POINT ZC 45H DIN	F81002-124	1	
10	BELT, 8 PJ 1355 MULTI-RIBBED	533679	1	

4.12 PRO Feed Drive 533650-U

533650\_002  
533650

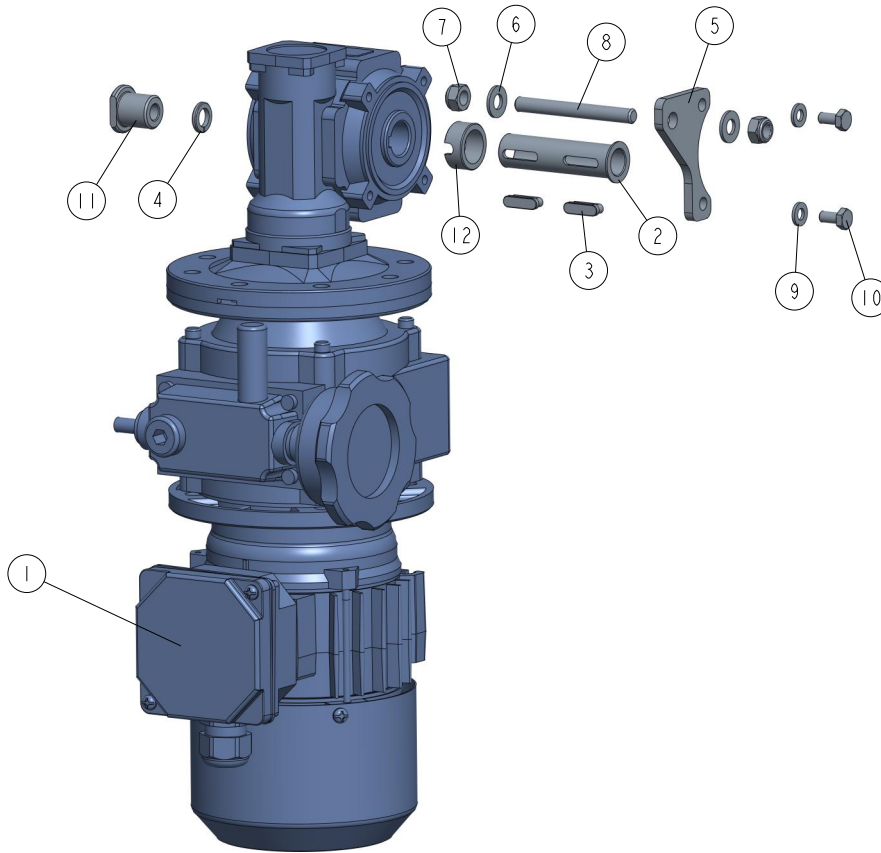

REF	DESCRIPTION (◆ indicates parts available in assemblies only)	PART #	QTY
-	<b>DRIVE, PRO FEED</b>	533650-U	1
1	MOTOREDUCER KC40/P 15+ NF003 + SKH63-2 <a href="#">See Section 4.13</a>	533640-UL	1
2	BUSHING, REDUCER	533731	1
3	KEY	533732	2
4	WASHER, 10.2 SPLIT LOCK ZINC	F81055-2	1
5	ARM, TORQUE	533734-1	1
6	WASHER, 8.4 ZINC FLAT	F81054-1	2
7	NUT, M8-8-B HEX NYLON ZINC LOCK	F81032-2	2
8	BOLT, M8	533635-1-6U	1
9	WASHER, 6.4 FLAT ZINC	F81053-1	2
10	BOLT, M6X12-8.8 HEX HEAD FULL THREAD ZIN	F81001-7	2
11	NUT, M10	533733-1-6U	1
12	BUSHING, REDUCER	541449	1

## 4.13 Motoreducer 533640-UL

533640\_001  
533640

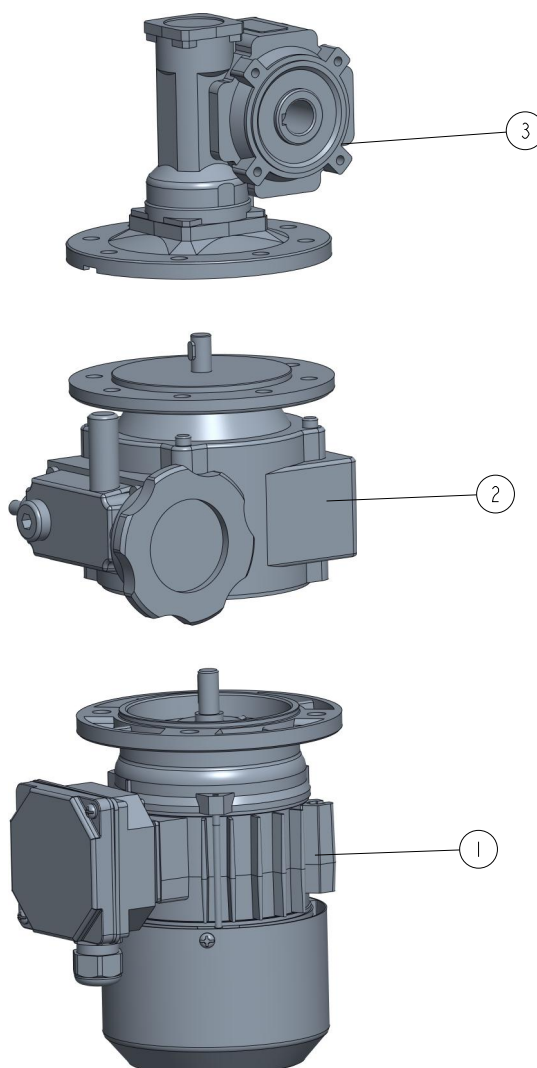

REF	DESCRIPTION (◆ indicates parts available in assemblies only)	PART #	QTY	
-	MOTOREDUCER 2SIEK6-2C UL/CSA + NF003 + KC40/P	533640-UL	1	
1	MOTOR, SKH63-2C2/x UL	533642-UL	1	
2	SPEED VARIATOR NF003 140/11 V3	533643	1	
3	REDUCER KC40 P15 63 B5 V6 H18 3D	533641	1	



4.14 PRO Feed Drive 533650-6U

533650-6U\_001  
533650-6U\_MANUAL

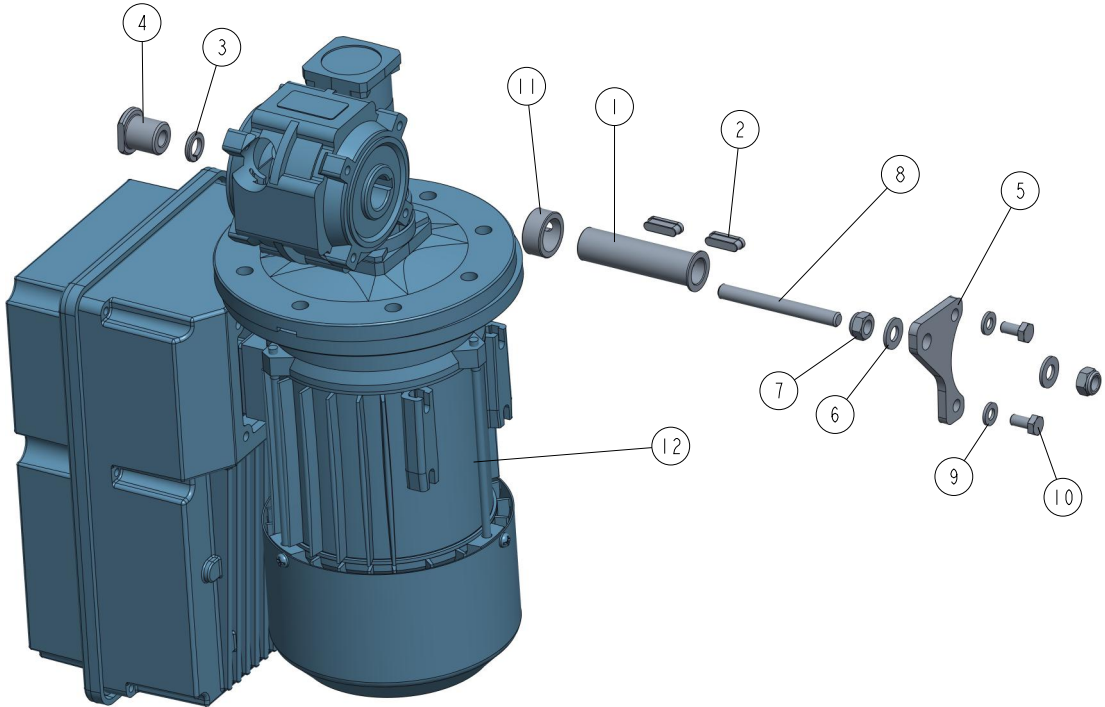

REF	DESCRIPTION (◆ indicates parts available in assemblies only)	PART #	QTY
-	<b>PRO FEED DRIVE</b>	533650-6U	1
1	BUSHING, REDUCER	533731	1
2	KEY	533732	2
3	WASHER, Z 10.2 SPLIT LOCK ZINC	F81055-2	1
4	NUT, M10	533733-1-6U	1
5	ARM, TORQUE	533734-1	1
6	WASHER, 8.4 FLAT,ZINC	F81054-1	2
7	NUT, M8-8-B HEX NYLON ZINC LOCK	F81032-2	2
8	BOLT, M8	533635-1-6U	1
9	WASHER, 6.4 FLAT ZINC	F81053-1	2
10	BOLT, M6X12-8.8 HEX HEAD FULL THREAD ZIN	F81001-7	2
11	BUSHING, REDUCER	541449	1
12	UP/DOWN DRIVE <a href="#">See Section 4.15</a>	597559	1

## 4.15 Up/Down Drive 597559

597559\_001  
597559

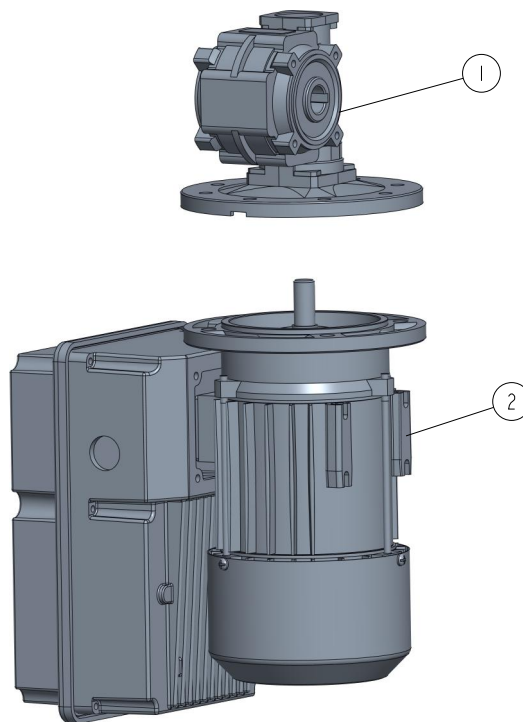

REF	DESCRIPTION (◆ indicates parts available in assemblies only)	PART #	QTY	
-	UP/DOWN DRIVE	597559	1	
1	REDUCER KC40/P15 160/14 V6 H18	535749	1	
2	MOTOR, 2SIEK71X-4C/T	592832	1	

## 4.16 ECO Feed Drive 533638-U

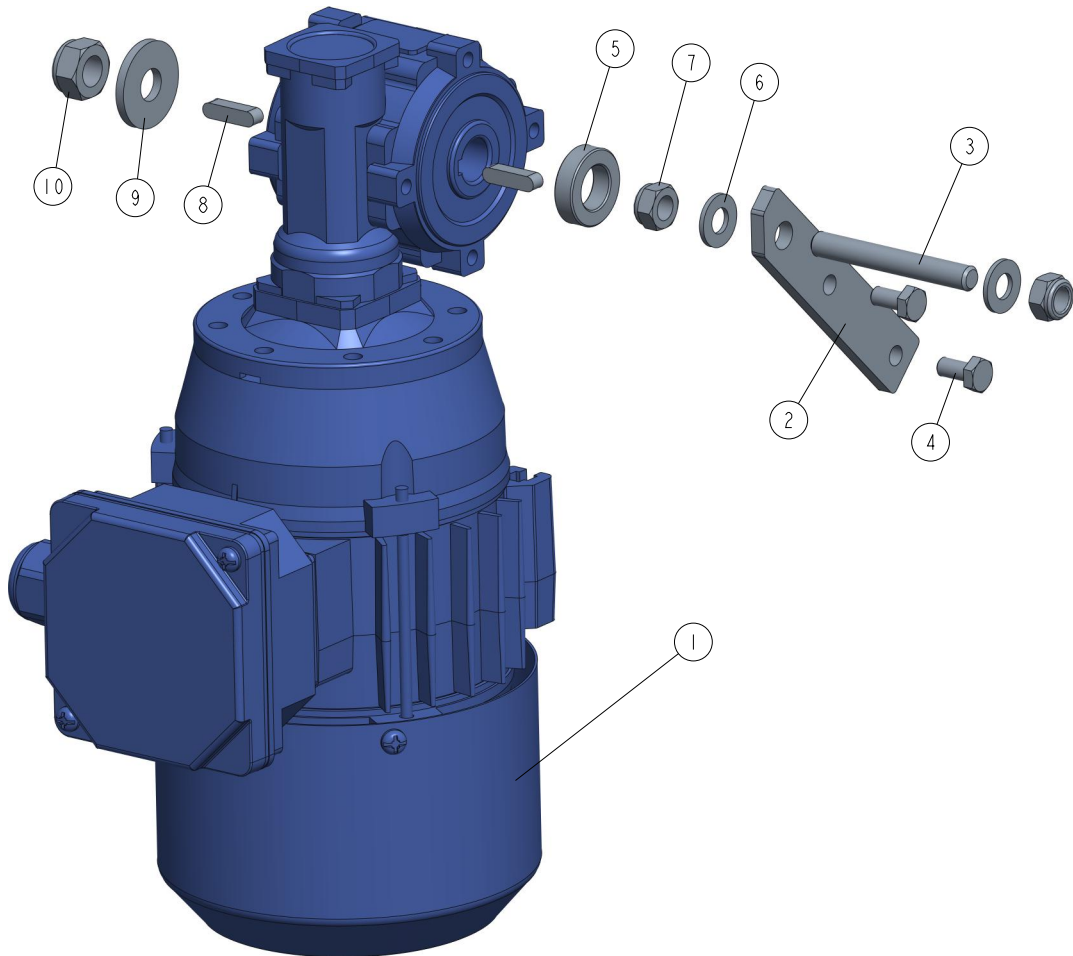
533638\_001\_B  
533638\_MANUAL

REF	DESCRIPTION (◆ indicates parts available in assemblies only)	PART #	QTY
-	DRIVE, MP200 ECO FEED	533638-U	1
1	MOTOREDUCTER, SKH63-4B2/X UL/CSA + KC30/ <a href="#">See Section 4.17</a>	533639-UL	1
2	ARM, TORQUE	533634-1	1
3	BOLT, M8	533635-1	1
4	BOLT M6X12 HH ZC FT 8.8 DIN 933	F81001-7	2
5	BUSHING, 14.3/25-7 ZINC-PLATED	533636-1	1
6	WASHER, 8.4 FLAT ZINC	F81054-1	2
7	NUT, M8 8 HEX NYLON ZINC LOCK	F81032-2	2
8	KEY, A5X5X20 PARALLEL	513320	2
9	WASHER, 10.5 SPECIAL FLAT ZINC	F81055-6	1
10	NUT, M10-8-B HEX NYLON ZINC LOCK	F81033-1	1

## 4.17 Motoreducer 533639-UL

533639\_001  
533639

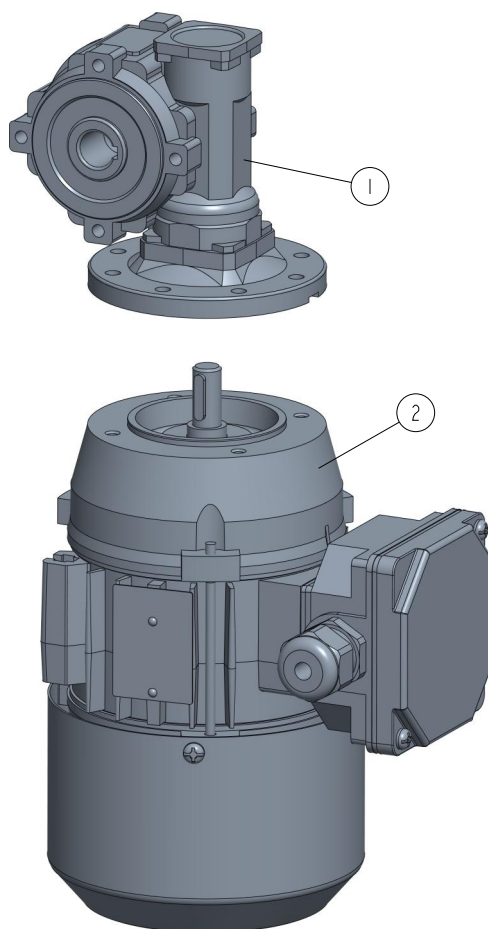

REF	DESCRIPTION (◆ indicates parts available in assemblies only)	PART #	QTY	
-	MOTOREDUCER, SKh63-4B2/X UL/CSA + KC30/P 30	533639-UL	1	
1	REDUCER, KC30/P30 90/11 V6	533637	1	
2	MOTOR, SKH 63-4B2 UL	532802-UL	1	

4.18 ECO Feed Drive 533638-6U

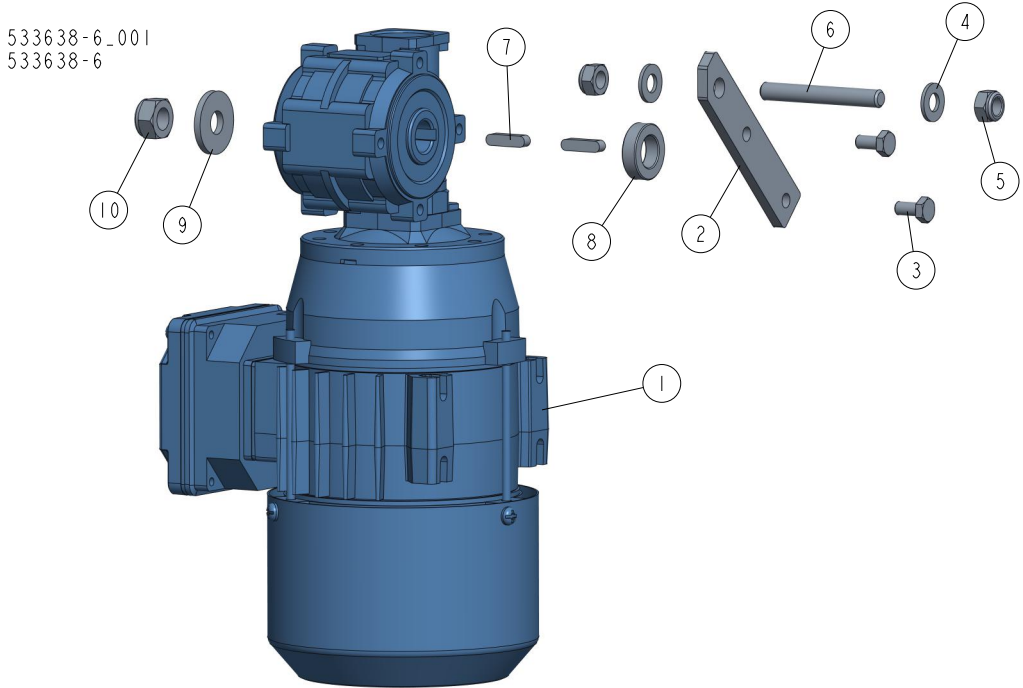

REF	DESCRIPTION (◆ indicates parts available in assemblies only)	PART #	QTY
-	<b>DRIVE, MP200 ECO FEED</b>	533638-6U	1
1	MOTOREDUCER KC30/P 30 + SEMKh63-4C2/X <a href="#">See Section 4.19</a>	533654-UL	1
2	ARM, TORQUE	533634-1	1
3	BOLT M6X12 8.8 FE/ZN5 PN-85/M-82105	F81001-7	2
4	WASHER, 8,4-FLAT ZINC	F81054-1	2
5	NUT, M8-8-B HEX NYLON ZINC LOCK	F81032-2	2
6	BOLT, M8	533635-1	1
7	KEY, A5X5X20 PARALLEL	513320	2
8	BUSHING, 14.3/25-7 ZINC-PLATED	533636-1	1
9	WASHER, 10.5 ZINC FLAT SPECIAL	F81055-6	1
10	NUT, M10-8-B NYLON HEX ZINC LOCK	F81033-1	1

## 4.19 Motoreducer 533654-UL

533654\_001  
533654

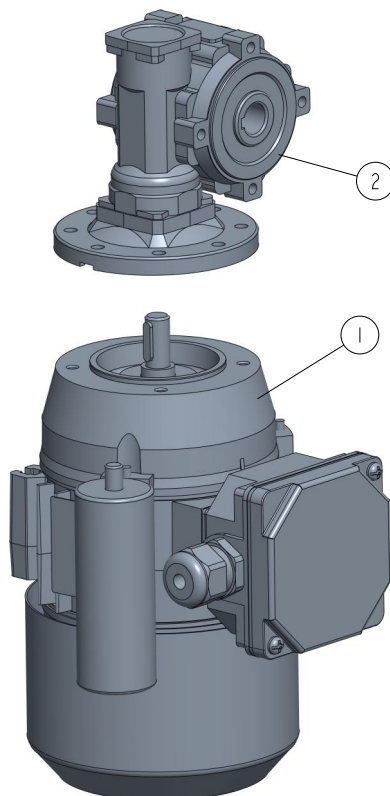

REF	DESCRIPTION (◆ indicates parts available in assemblies only)	PART #	QTY	
-	<b>MOTOREDUCER KC30/P 30 + SEMKh63-4C2/X</b>	533654-UL	1	
1	MOTOR, SKH63-4C2/X 0,18KW,1580 RPM, IEC63B14/2,1X230, 60HZ	535712-UL	1	
2	REDUCER, KC30/P30 90/11 V6	533637	1	