



Safety, Operation, Maintenance & Parts Manual

Debarker Option

rev. A.01 - A.02



Safety is our #1 concern! Read and understand all safety information and instructions before operating, setting up or maintaining this machine.

March 2010

Form #1515

Table of Contents		Section-Page
SECTION 1	SAFETY	1-1
SECTION 2	INSTALLATION	2-1
2.1	LT300 Modification	2-1
2.2	Debarker Installation	2-5
2.3	Air Installation.....	2-6
2.4	Electrical Installation (LT300/WM3000/WM3500 Rev. B3.00+ Only).....	2-8
2.5	Electrical Installation (LT300 Rev. A1.00 - B2.02 Only).....	2-14
2.6	Electrical Installation (WM4000 Rev. A1.00+ Only).....	2-20
SECTION 3	ALIGNMENT	3-1
SECTION 4	OPERATION	4-1
SECTION 5	MAINTENANCE	5-1
SECTION 6	REPLACEMENT PARTS	6-1
6.1	Debarker (Complete).....	6-1
6.2	Debarker (Complete).....	6-2
6.3	Debarker	6-3
6.4	Swing Arm Assembly.....	6-4
6.5	Cutting Head Assembly.....	6-6
6.6	Pivot Arm Assembly	6-8
6.7	Air Box Assembly	6-9
SECTION 7	ELECTRICAL INFORMATION	7-1
7.1	Schematic (LT300/WM3000/WM3500 Rev. B3.00+ Only).....	7-1
7.2	Schematic (WM4000 Rev. A1.00+ Only).....	7-1
7.3	Schematic (LT300 Rev. A1.00 - B2.02 Only).....	7-2
7.4	Control Layout (LT300/WM3000/WM3500 Rev. B3.00+ Only).....	7-3
7.5	Control Layout (WM4000 Rev. A1.00+ Only).....	7-4
7.6	Control Layout (LT300 Rev. A1.00 - B2.02 Only).....	7-5
7.7	Component List (LT300/WM3000/WM3500 Rev. B3.00+ Only)	7-6
7.8	Component List (WM4000 Rev. A1.00+ Only).....	7-6
7.9	Component List (LT300 Rev. A1.00 - B2.02 Only)	7-6

SECTION 1 SAFETY



DANGER! Make sure all electrical installation, service and/or maintenance work is performed by a qualified electrician and is in accordance with applicable electrical codes.

DANGER! Hazardous voltage inside the electric control box and at the motor can cause shock, burns, or death. Disconnect and lock out power supply before servicing! Keep all electrical component covers closed and securely fastened during mill operation.



WARNING! Clean sawdust from all guards, vents, control boxes, or any area where sawdust may gather after every shift. Failure to do so may result in fire, causing death or serious injury.



WARNING! Make sure all guards and covers are in place and secured before operating the debarker option. Failure to do so may result in serious injury.

WARNING! Keep all persons out of the path of moving equipment when operating the debarker. Failure to do so will result in serious injury.



WARNING! Before replacing the debarker blade, move the sawmill blade guide arm in front of the sawmill blade to cover the blade teeth. Failure to do so may result in serious injury or death.

SECTION 2 INSTALLATION

Move the saw head to a location and height where the head air box and area between the blade wheels is easily accessible.

Turn the sawmill off and lock out electrical power.



DANGER! Hazardous voltage inside the electric control box and at the motor can cause shock, burns, or death. Disconnect and lock out power supply before servicing!

Release the blade tension and remove the sawmill blade, if necessary. Turn the main air valve off.

2.1 LT300 Modification

Older LT300 sawmills must be modified to accommodate the debarker option. If your LT300 is Rev. B1.01 or newer, skip to [Section 2.2](#).

NOTE: LT300's prior to Rev. A8.00 with the original Yaskawa AC drives must be upfitted with the Altivar drive kit 052403 before the debarker retrofit is installed. Follow the instructions supplied with the drive kit before proceeding with this retrofit.

See Figure 2-1. Use the provided template to mark the area in saw head throat. Use a die grinder and/or metal saw to remove the section.

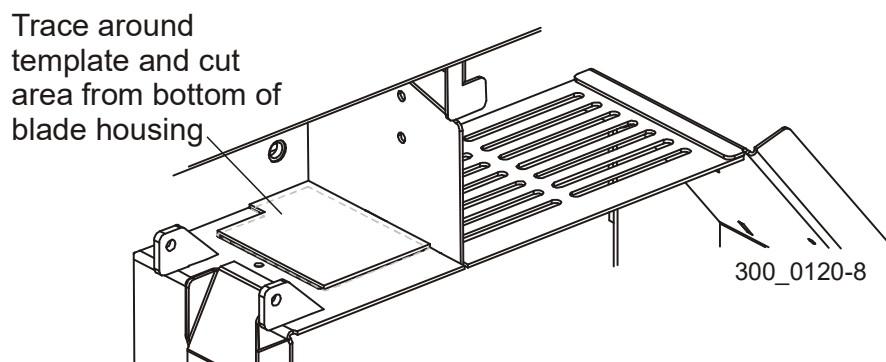

FIG. 2-1

See Figure 2-2. Place the second template against the blade housing angle and mark the two hole locations. Drill two 5/16" diameter holes through the housing.

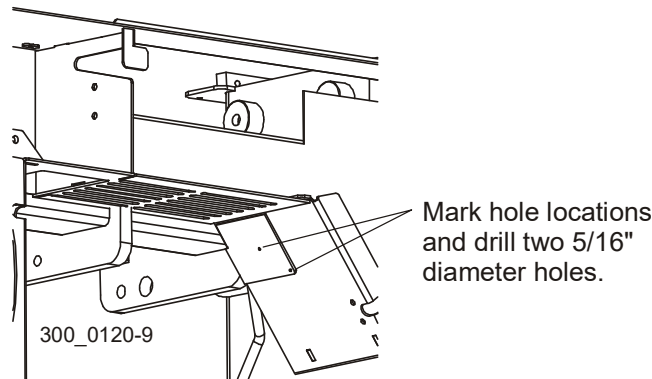

FIG. 2-2

See Figure 2-3. Install the drilling fixture to the saw head. Place the fixture so the horizontal positioning bolts are against the board return braces and the vertical positioning bolt is against the bottom of the saw head tube. Tighten the two clamping bolts to secure the fixture to the saw head.

Install the 3/16" guide bushing to one of the fixture holes and drill a 3/16" hole through both walls of the saw head tube. Move the bushing to the other hole and repeat. Install the 5/8" guide bushing to the bottom hole and drill through both walls. Install the 17/32" guide bushing to the top hole and drill through both walls. Remove the fixture.

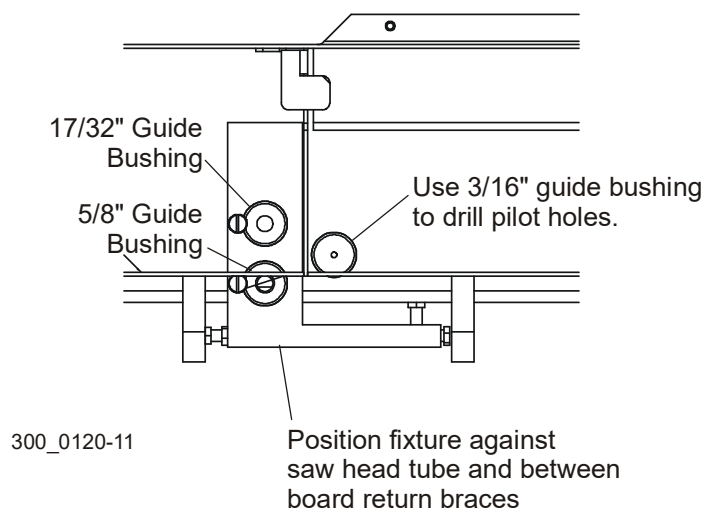

FIG. 2-3

2

Installation

LT300 Modification

See Figure 2-4. Install the third template around the existing screws at the top of the side of the head air box. Mark the two hole locations and drill two 5/16" holes through the box wall. Check as the drill bit enters the box that it does not contact any existing components or air lines.

Mark two locations on the side of the head air box and drill two 1/2" diameter holes, again being careful not to contact any existing components or air lines inside the box.

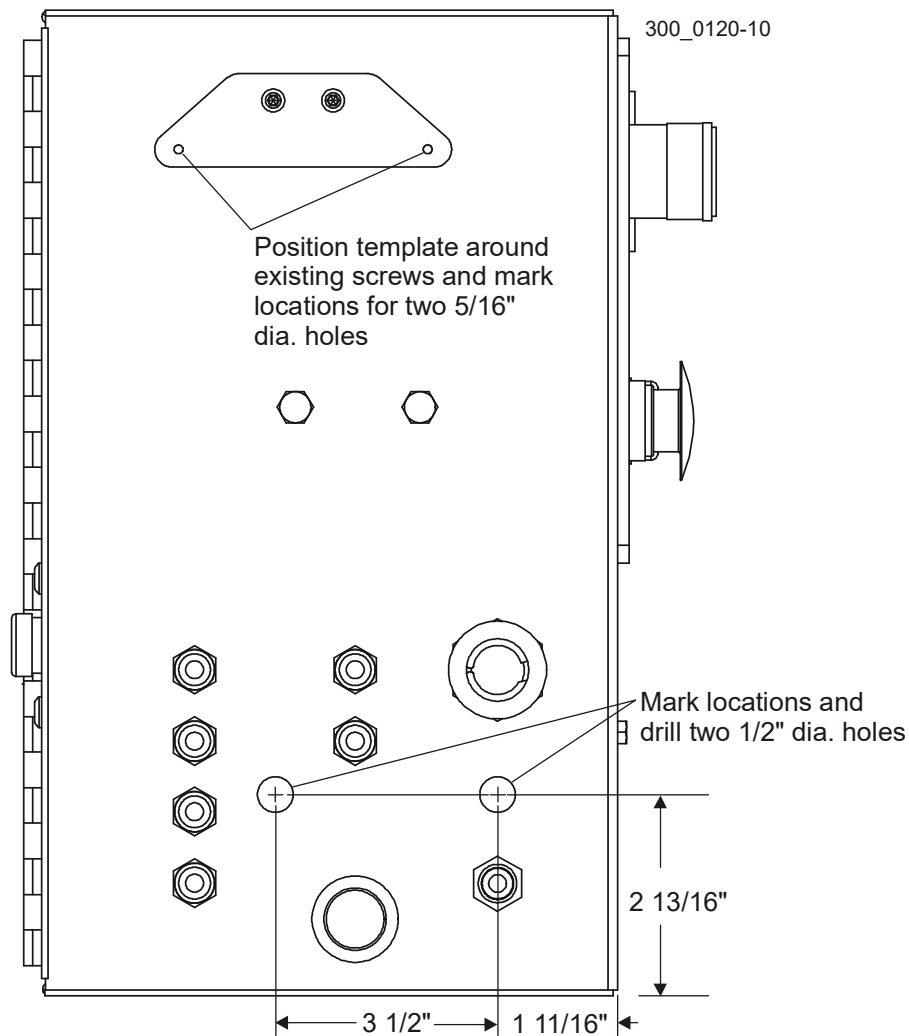

FIG. 2-4

See **Figure 2-5**. In the control cabinet, drill two 7/8" holes in the back of the cabinet as indicated.

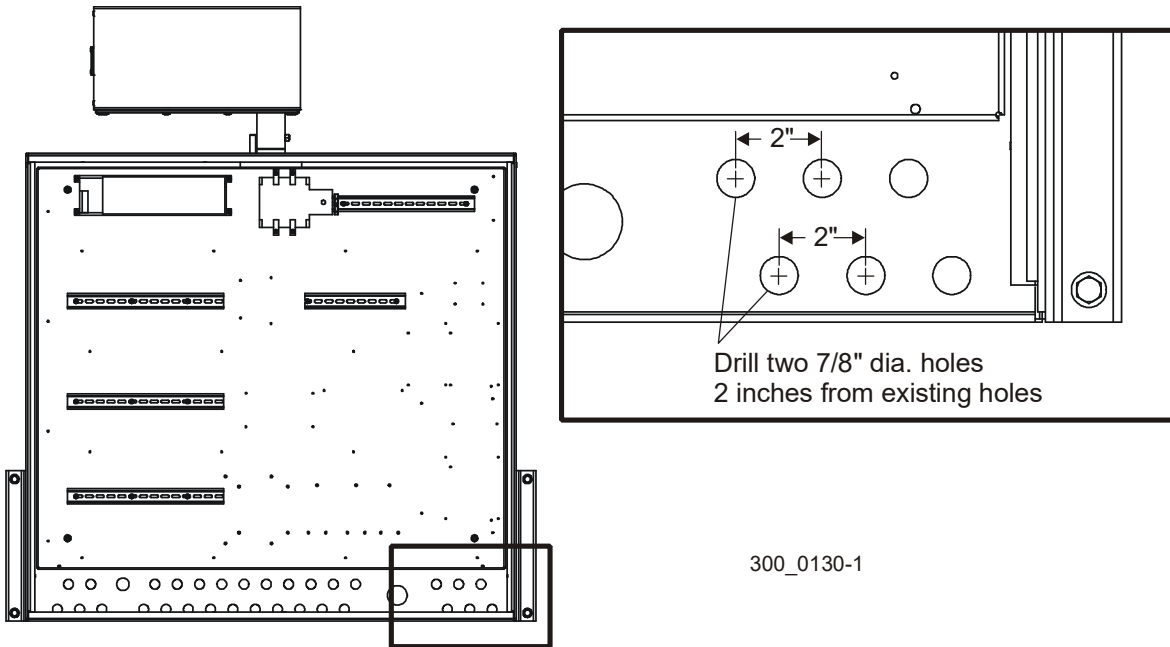

FIG. 2-5

Reprogram the display and CPU.

2.2 Debarker Installation

NOTE: LT300 sawmills prior to Rev. B1.01 must be modified before the debarker option can be installed ([See Section 2.1](#)).

Remove the debarker mounting bolts and lock washers from the mounting block assembly. Remove the cylinder arm mounting bolts, flat washers and lock nuts from the cylinder arm mounting plate.

Position the debarker against the saw head tube, aligning the mounting holes to the holes in the saw head tube and the holes in the cylinder arm plate with the holes in the blade housing angle.

Secure the debarker to the saw head with the mounting bolts and lock washers. Secure the cylinder arm to the blade housing with the mounting bolts, flat washers and lock nuts.

See Figure 2-6.

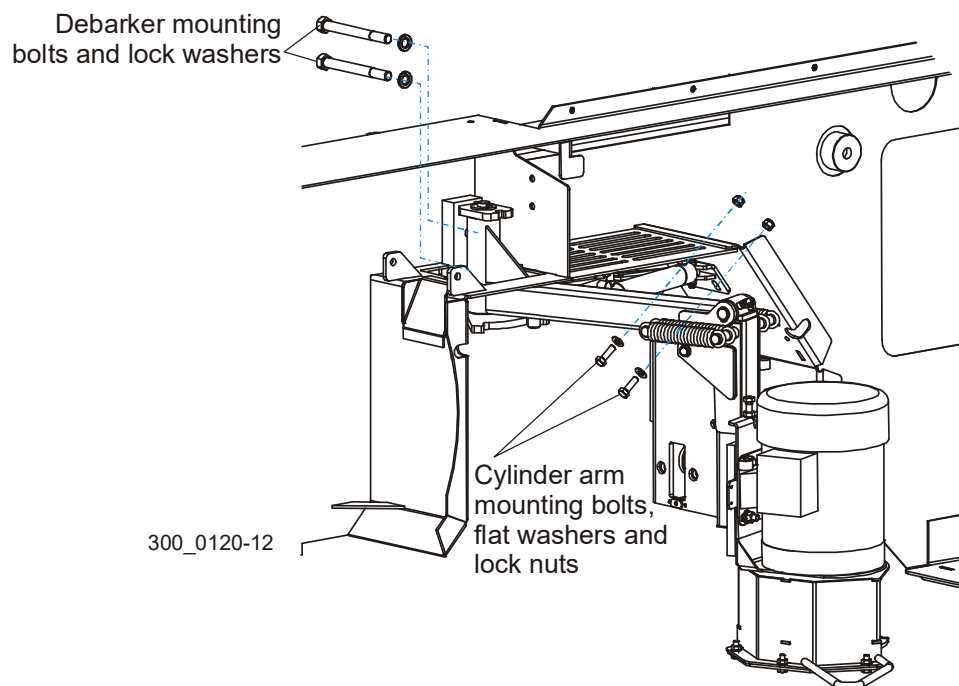

FIG. 2-6

2.3 Air Installation

See **Figure 2-7**. Using the provided 1/4" air tubing, connect the regulator to the gauge and the solenoid as shown below.

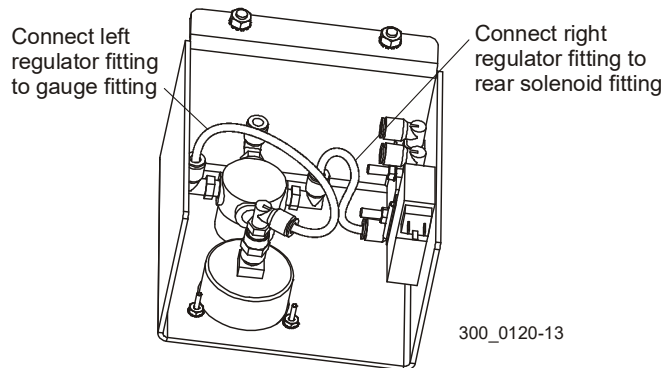

FIG. 2-7

See **Figure 2-8**. Mount the air control box to the saw head air box using the two mounting bolts and self-locking nuts supplied.

Install the provided 1/4" tube bulkhead fitting to the left-bottom hole in the air box.

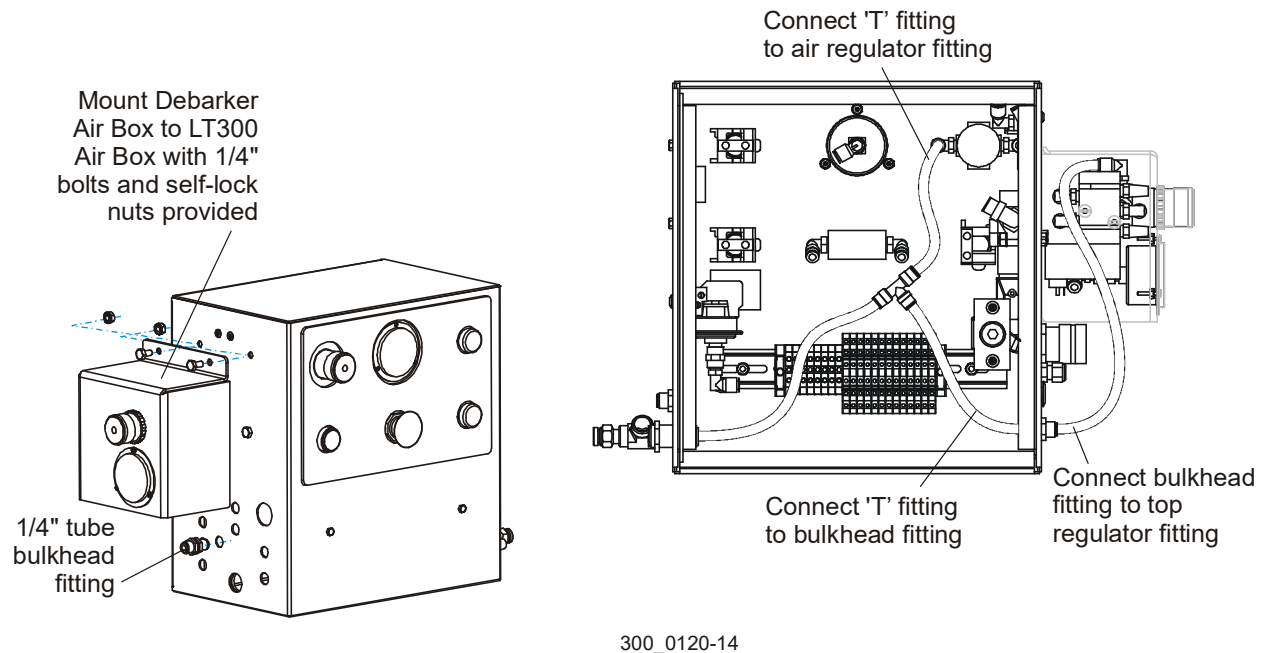

FIG. 2-8

2

Installation *Air Installation*

See **Figure 2-9**. Connect an air line to each of the air valve fittings. Route the lines through the saw head channel, through the clamp on the debarker and connect them to the debarker air cylinder fittings.

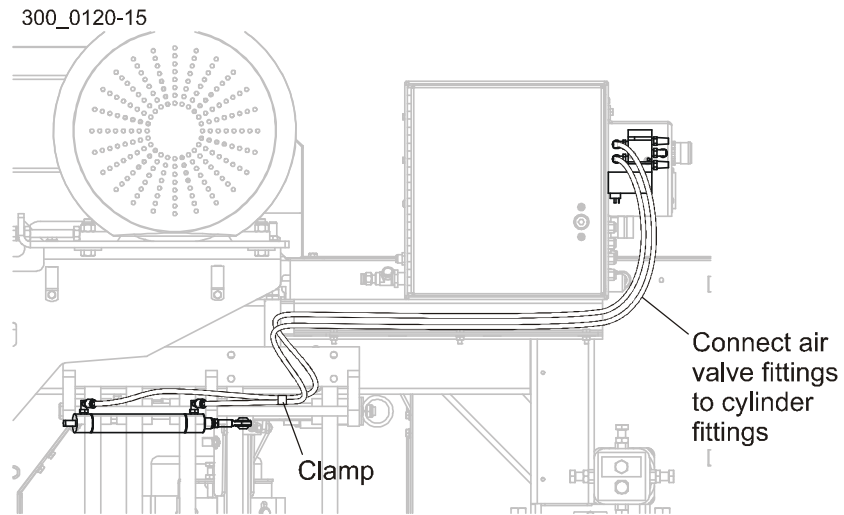

FIG. 2-9

Turn on the main air valve and adjust the debarker air regulator until the gauge indicates 40-80 psi.

2.4 Electrical Installation (LT300/WM3000/WM3500 Rev. B3.00+ Only)

See **Figure 2-10**. Install the provided fuses (FU12, FU13 & FU14) and contactor (K13) in the electrical control cabinet. Remove the rail clamps around the existing components as necessary to make room for the new components. Replace the rail clamps.

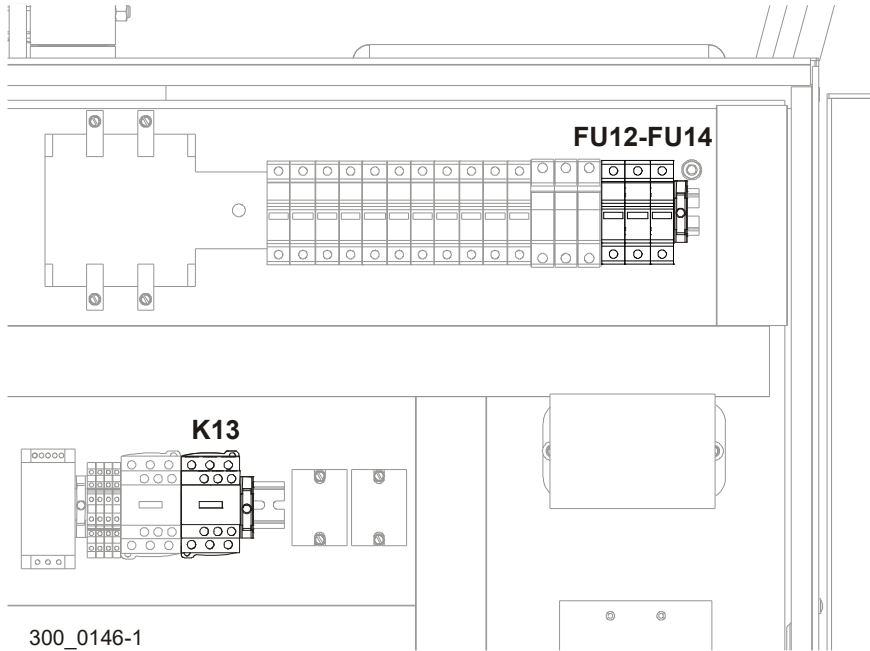

FIG. 2-10

2

Installation

Electrical Installation (LT300/WM3000/WM3500 Rev. B3.00+ Only)

See Figure 2-11. Use the wires #300, 301 & 302 to connect the fuses to the distribution block DB1 as shown below. Use the wires #375, 376 & 377 to connect the fuses to terminals L1, L2 & L3 of contactor K13.

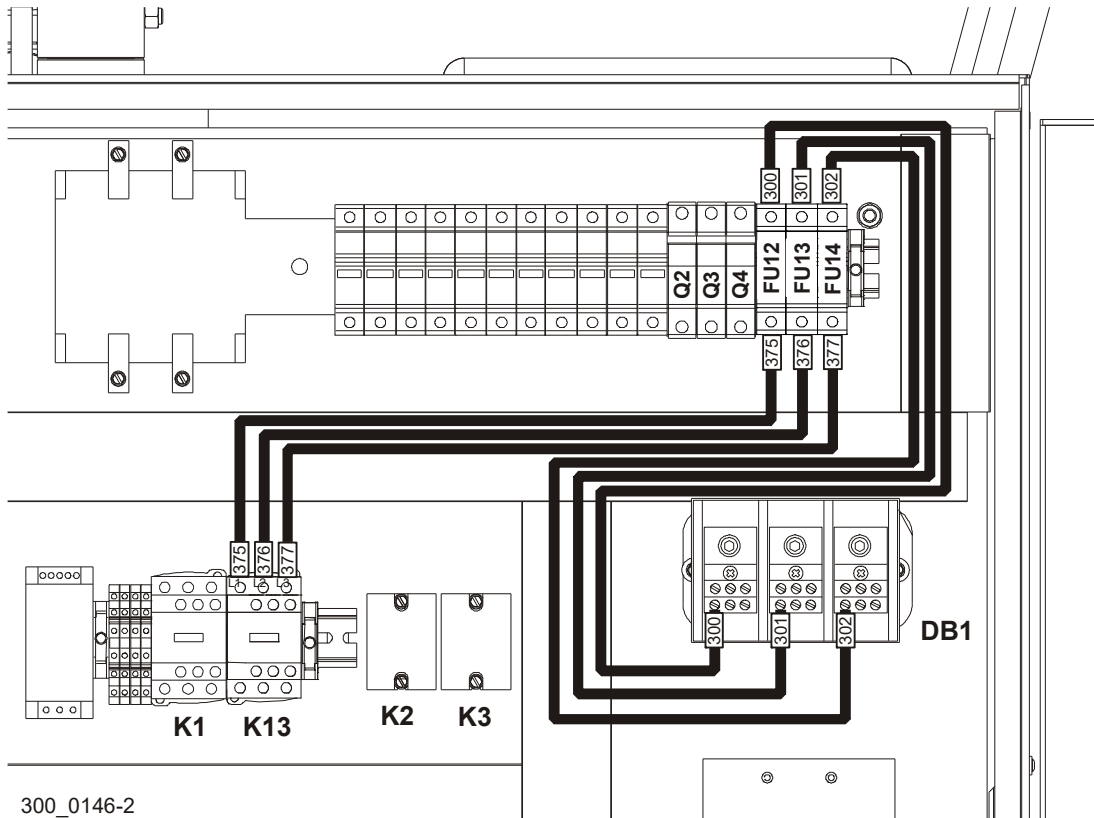

FIG. 2-11

See Figure 2-12. Place the foot switch on the floor of the operator station and route the cable to the electrical cabinet. Insert the cable through one of the holes in the bottom of the cabinet and secure with the cable connector provided. Connect the green ground wire to the grounding bar in the bottom of the cabinet. Remove wireway covers as necessary and route black wire #378 to PCB2 module and connect to terminal A5. Route white wire #53 to terminal block X19 and connect to terminal B2.

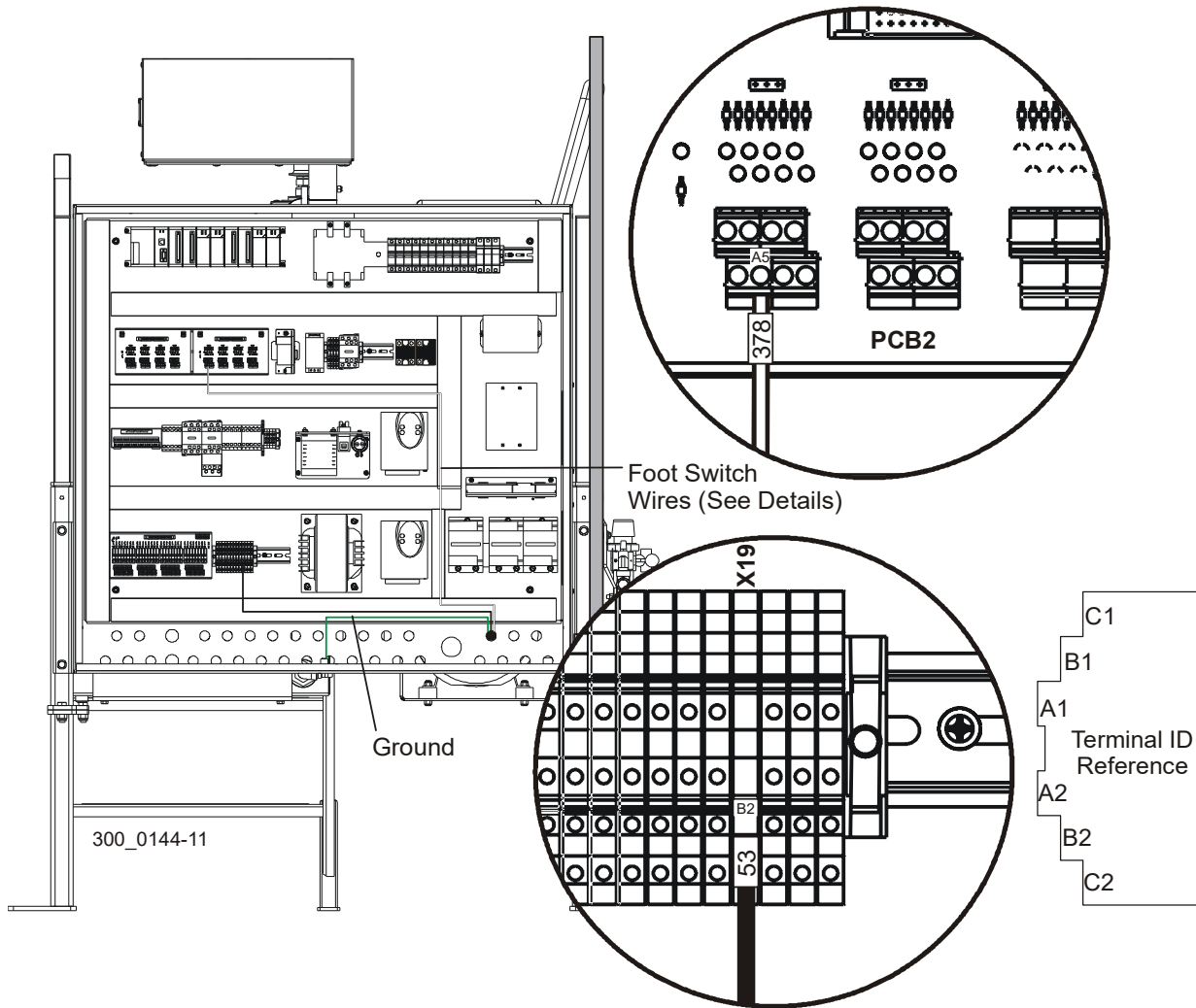

FIG. 2-12

2

Installation

Electrical Installation (LT300/WM3000/WM3500 Rev. B3.00+ Only)

See Figure 2-13. Install the debarker motor harness to the remaining hole at the bottom of the electrical cabinet and secure with the connector provided. Connect the green ground wire to the grounding bar at the bottom of the cabinet. Route wires #21, 22 & 23 to contactor K13. Connect wire #21 to K13 terminal T1, wire #22 to K13 terminal T2 and wire #23 to K13 terminal T3.

Route wire #53 to terminal block X19 and connect to terminal A2. Route wire #379 to PCB2 module and connect to terminal A6.

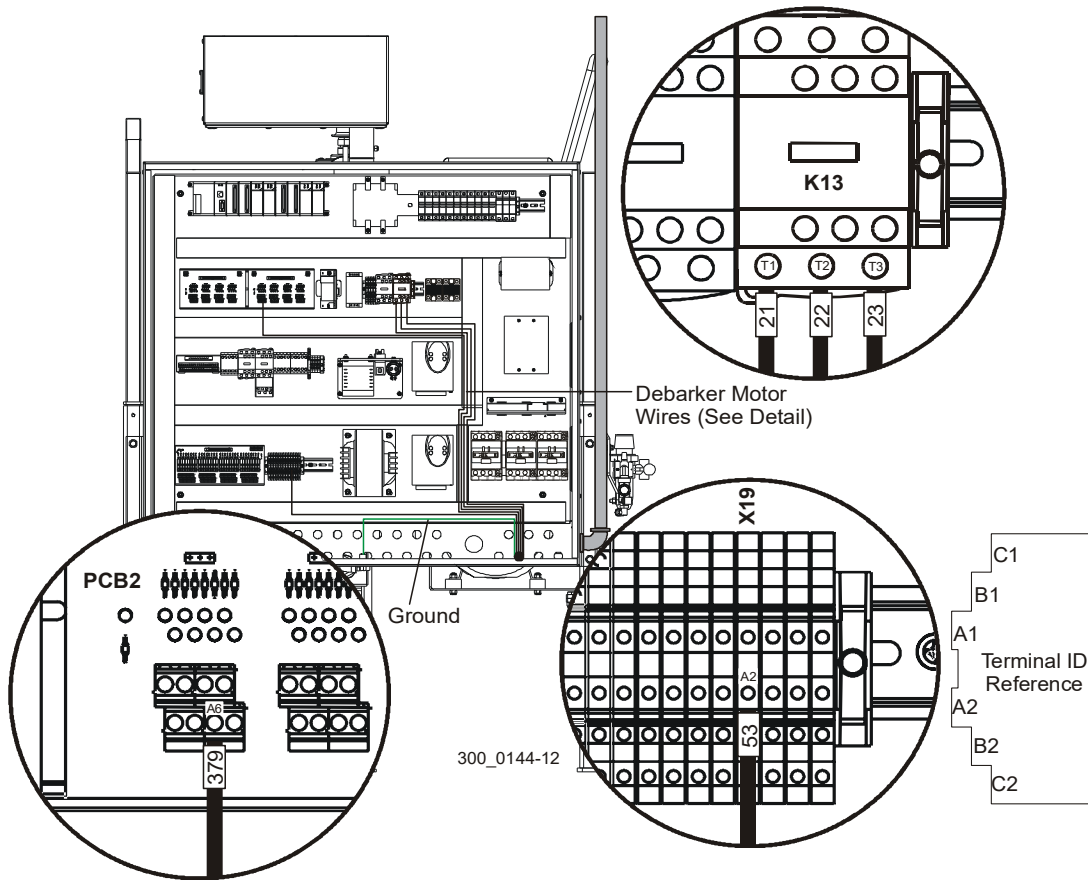

FIG. 2-13

Route the motor harness from the electrical cabinet, underneath the operator station, through the pantograph cable boom (or wireway and cable carrier for LT300 without pantograph cable boom). Use the supplied strain relief brackets to secure the debarker motor harness to the pantograph. Continue routing the harness underneath the saw motor to the debarker motor. Open the debarker motor terminal housing and use wire nuts to connect wire #21 to debarker wire T1, wire #22 to terminal wire T2, wire #23 to wire T3, wire #53 to wire J2 and wire #379 to wire J1. Connect motor wire T4 to T7, T5 to T8 and T6 to T9. Connect the green ground wire to the motor ground terminal and replace the terminal housing cover.

See Figure 2-14. Install the blue debarker control wires as shown.

Wire #381 from contactor K13, terminal 13 to terminal block X20, terminal A1.

Wire #382 from contactor K13, terminal A2 to PCB3, top terminal B6.

Wire #53 from contactor K13, terminal 14, to terminal block X19, terminal A1.

Wire #55 from contactor K13, terminal A1 to terminal block X14, terminal A2.

Locate wire #4 (or #381) from the head/air box labeled “spare” in the electrical box. If necessary, connect wire #4 (#381) to terminal block X20, terminal A2.

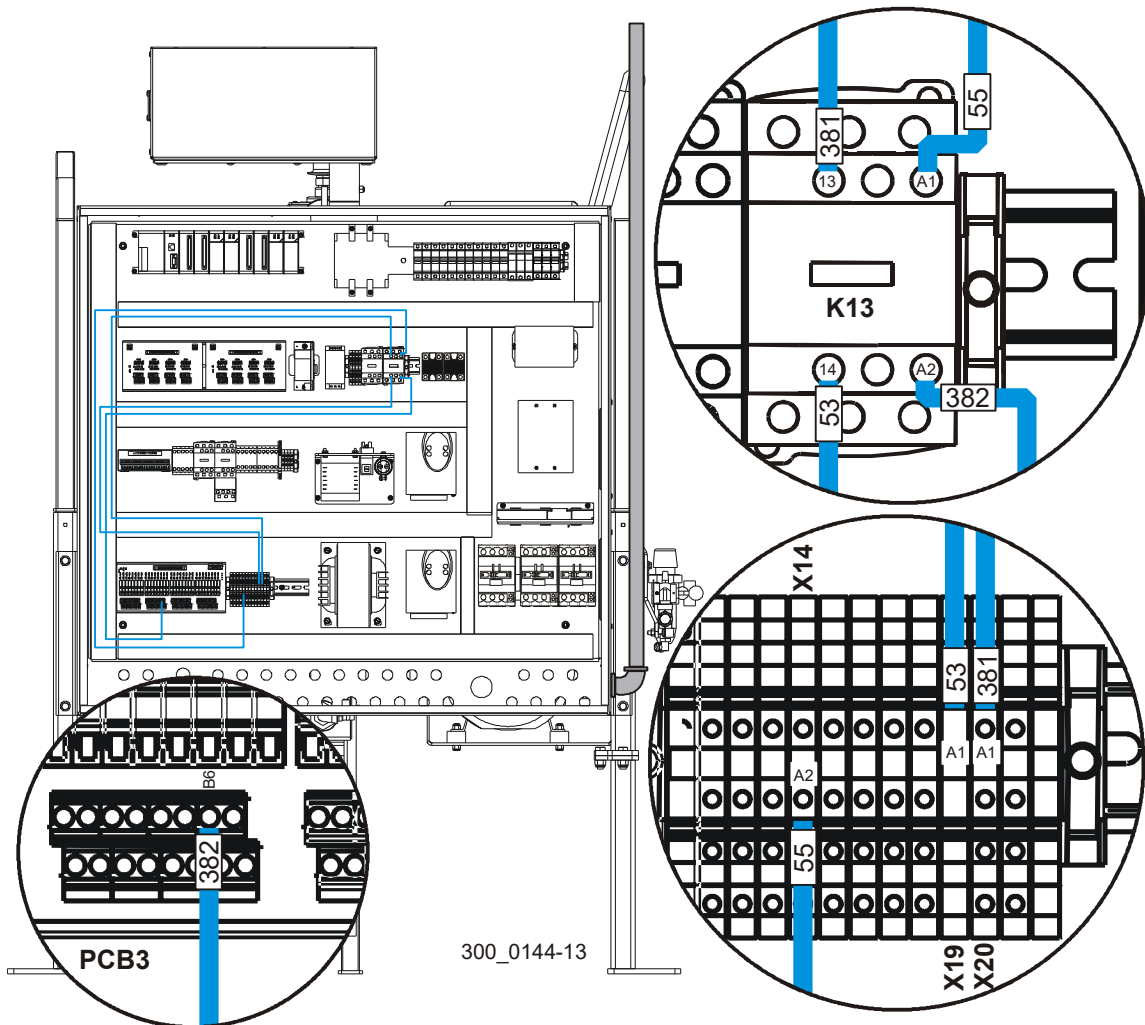

FIG. 2-14

2

Installation

Electrical Installation (LT300/WM3000/WM3500 Rev. B3.00+ Only)

See **Figure 2-15**. Connect the supplied DIN cable to the air solenoid valve in the debarker air control box. Route the cable through the side of the saw air box and secure with the cable connector. In the saw air box, connect wire #381 to terminal block X50, terminal A1. Connect wire #68 to terminal block X48, terminal A2.

Locate wire #4 (or #381) labeled "spare" in the saw air box. If necessary, connect wire #4 (#381) to terminal block X50, terminal A2.

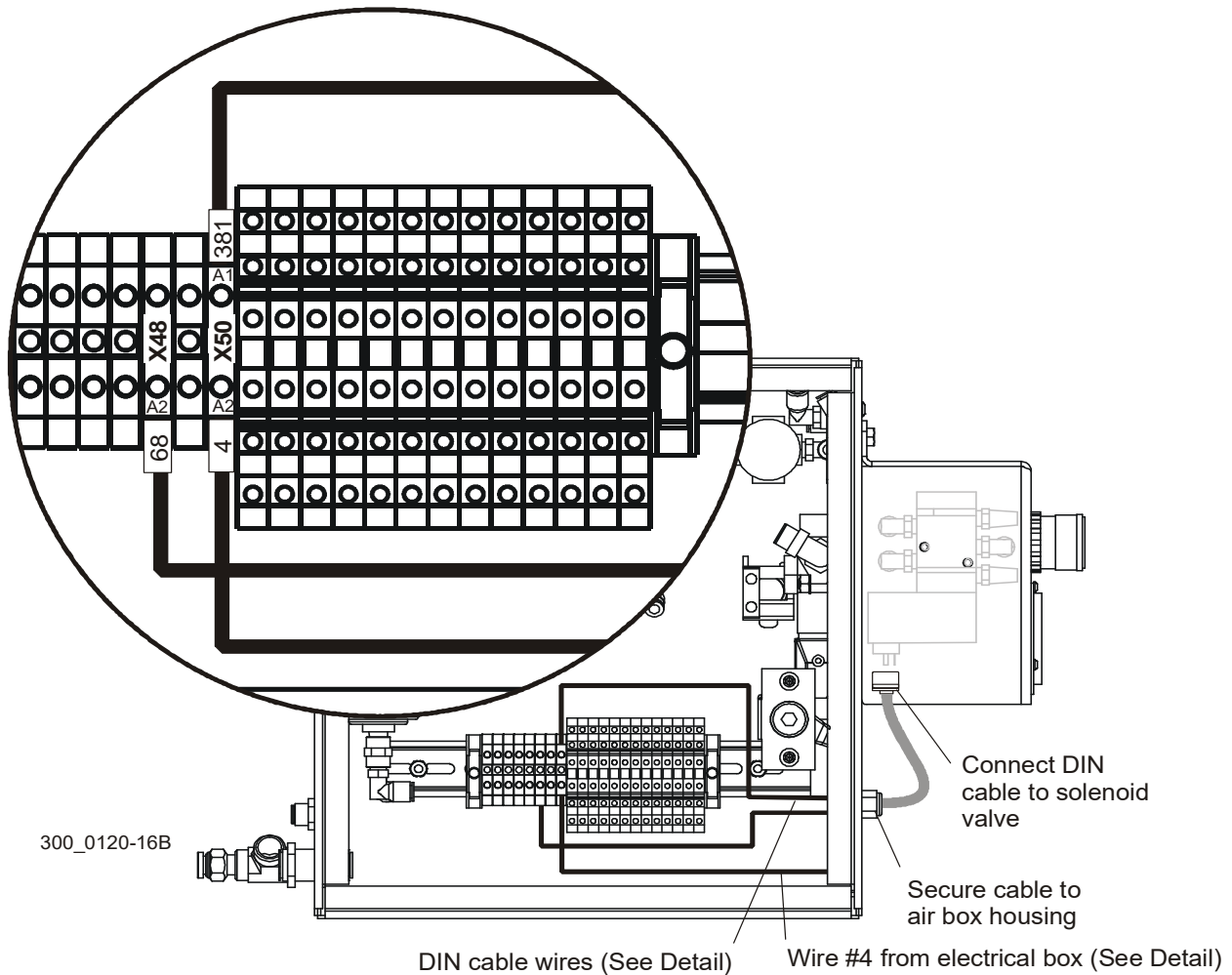

FIG. 2-15

This completes the debarker installation. If, during operation, the debarker moves opposite of proper operation, exchange the position of the air hoses connecting the debarker air cylinder to the valve.

2.5 Electrical Installation (LT300 Rev. A1.00 - B2.02 Only)

See **Figure 2-16**. Install the provided fuses (F3, F4 & F5), contactor (DB1) and relay (K38) in the electrical control cabinet. Remove the rail clamps around the existing components as necessary and slide the components to make room for the new components. Replace the rail clamps.

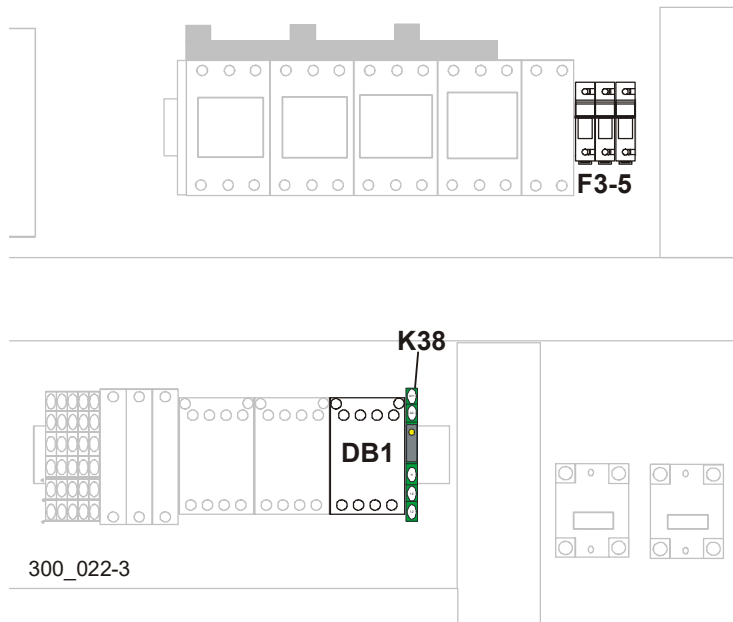

FIG. 2-16

2

Installation

Electrical Installation (LT300 Rev. A1.00 - B2.02 Only)

See Figure 2-17. Use the jumper wires (300, 301 & 302) to connect the fuses. Connect wire #300 to breaker Q7, terminal #1 and to fuse F3. Connect wire #301 to breaker Q7, terminal #3 and to fuse F4. Connect wire #302 to terminal lug W1, terminal #X3 and to fuse F5. Use jumper wires (375, 376 & 377) to connect the fuses to terminals L1, L2 & L3 of contactor DB1.

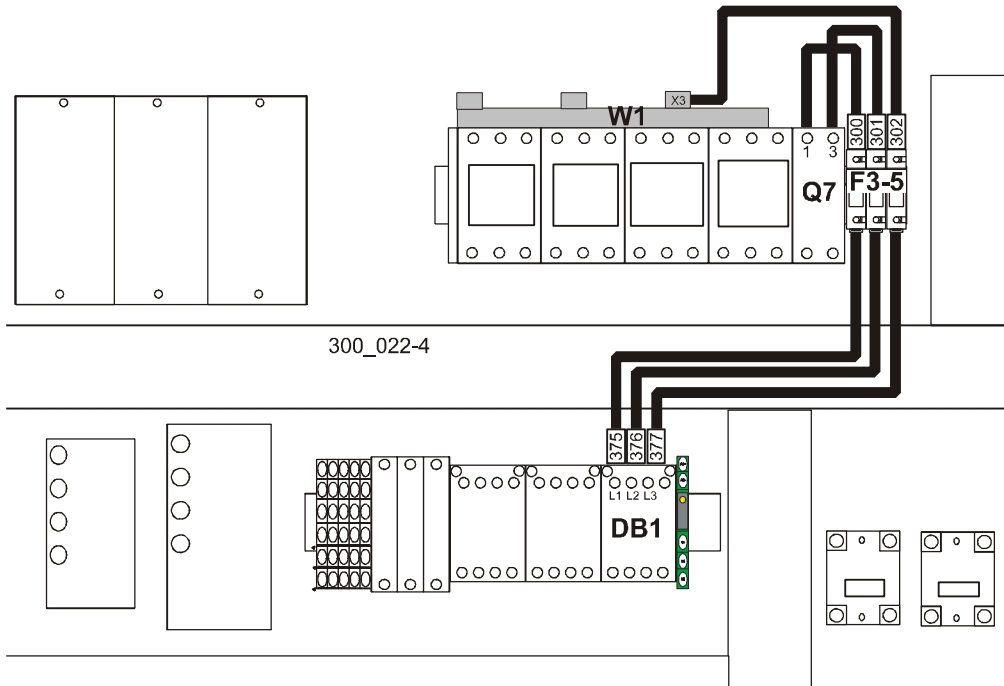

FIG. 2-17

See Figure 2-18. Place the foot switch on the floor of the operator station and route the cable to the electrical cabinet. Insert the cable through one of the holes in the bottom of the cabinet and secure with the cable connector provided. Connect the green ground wire to the grounding bar in the bottom of the cabinet. Remove wireway covers as necessary and route black wire #378 to PLC module X5 and connect to terminal A5. Route white wire #53 to contactor K2 and connect to terminal A2.

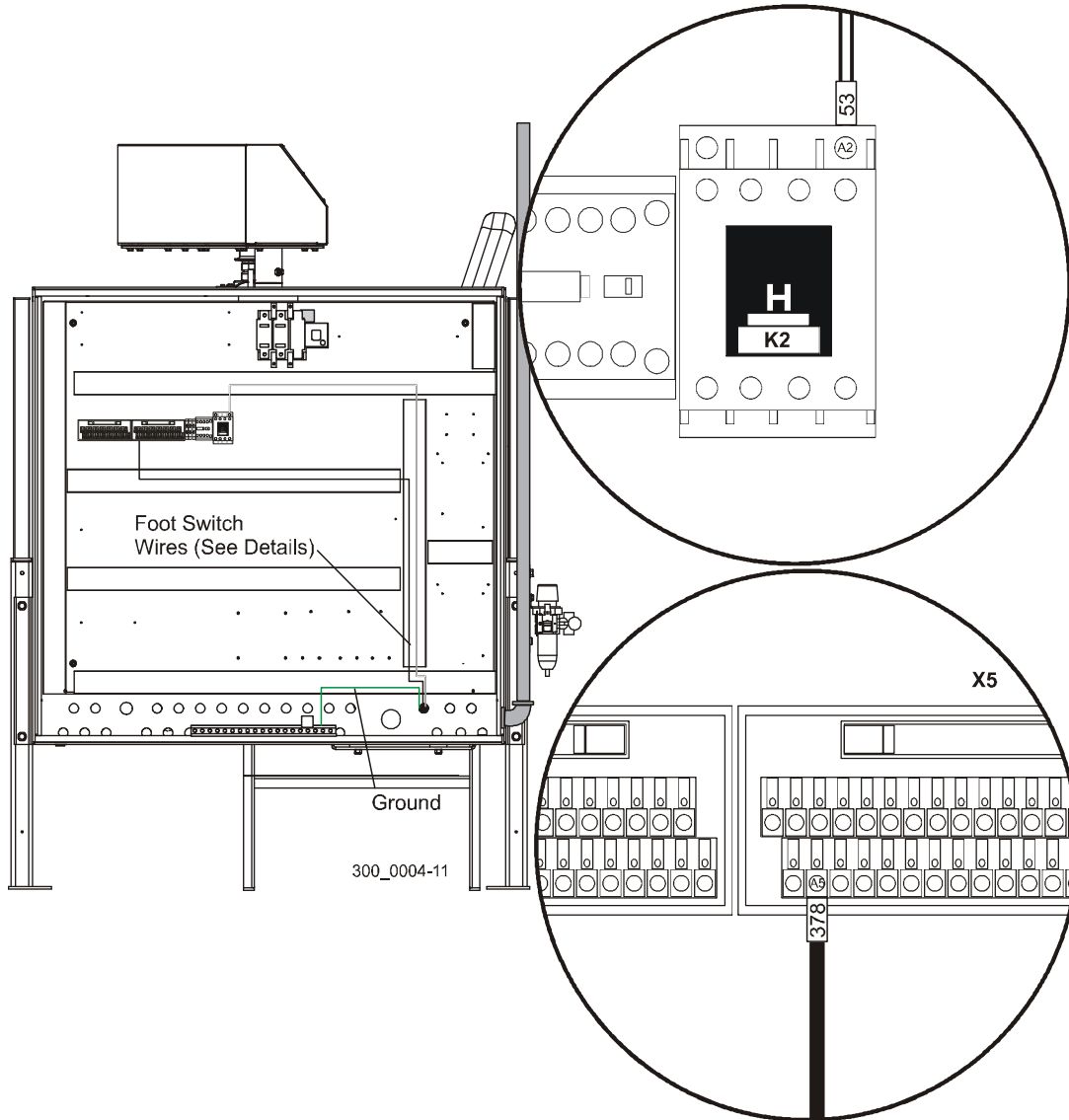

FIG. 2-18

2

Installation

Electrical Installation (LT300 Rev. A1.00 - B2.02 Only)

See Figure 2-19. Install the debarker motor harness to the remaining hole at the bottom of the electrical cabinet and secure with the connector provided. Connect the green ground wire to the grounding bar at the bottom of the cabinet. Route wires #21, 22 & 23 to contactor DB1. Connect wire #21 to DB1 terminal T1, wire #22 to DB1 terminal T2 and wire #23 to DB1 terminal T3.

Route wire #53 to contactor K1 and connect to terminal 44. Route wire #379 to PLC module X5 and connect to terminal A6.

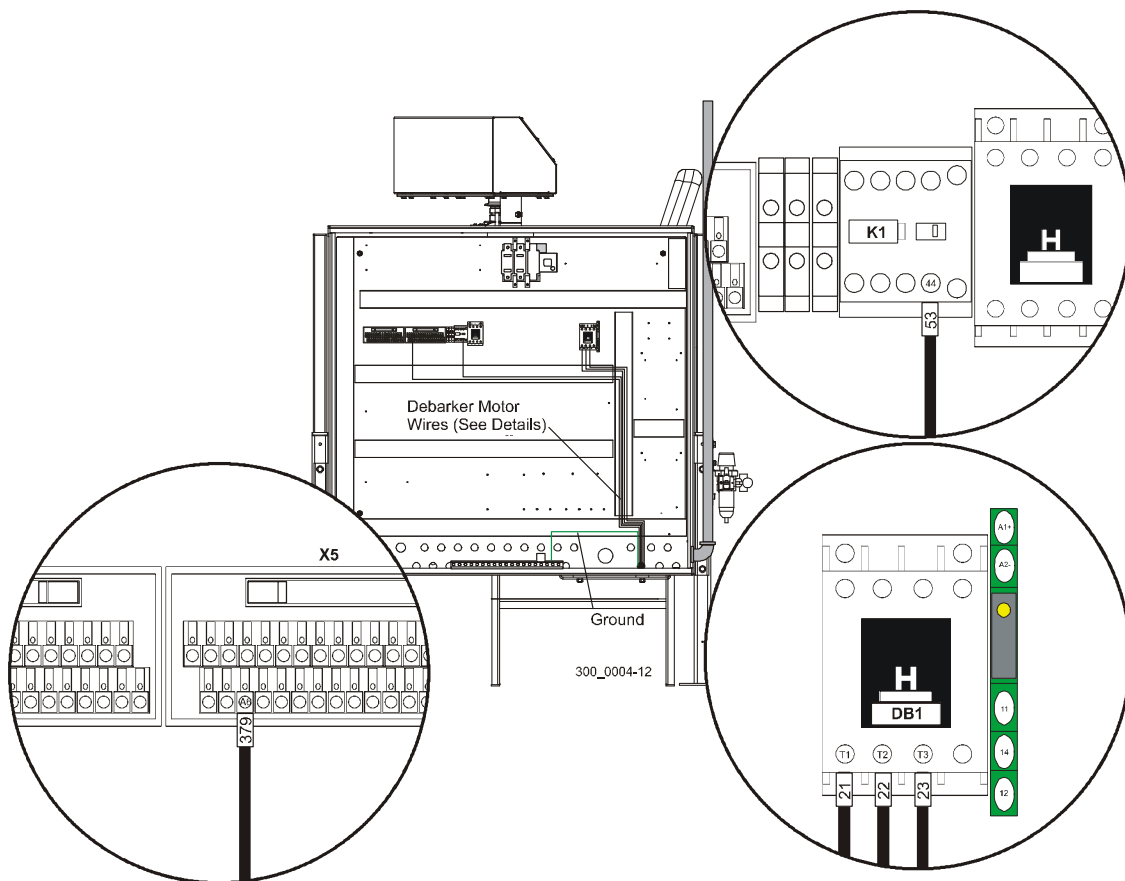

FIG. 2-19

Route the motor harness from the electrical cabinet, underneath the operator station, through the LT300 pantograph cable boom (or wireway and cable carrier for LT300 without pantograph cable boom). Continue routing the harness underneath the saw motor to the debarker motor. Open the debarker motor terminal housing and use wire nuts to connect wire #21 to debarker wire T1, wire #22 to terminal wire T2, wire #23 to wire T3, wire #53 to wire J2 and wire #379 to wire J1. Connect motor wire T4 to T7, T5 to T8 and T6 to T9. Connect the green ground wire to the motor ground terminal and replace the terminal housing cover.

See Figure 2-20. Install the blue debarker control wires as shown.

Wire #380 from relay K38, terminal A2 to PLC module X15, terminal B6.

Wire #381 from contactor DB1, terminal 13 to terminal block X29, terminal A1.

Wire #382 from contactor DB1, terminal A2 to relay K38, terminal 11.

Wire #53 from contactor K4, terminal A2, to relay DB1, terminal 14 and relay K38, terminal 14..

Wire #55 from contactor DB1, terminal A1 to contactor K4, terminal A1 and relay K38, terminal A1.

Locate wire #4 from the head/air box labeled “spare” in the electrical box. Connect wire #4 to terminal block X29, terminal A2.

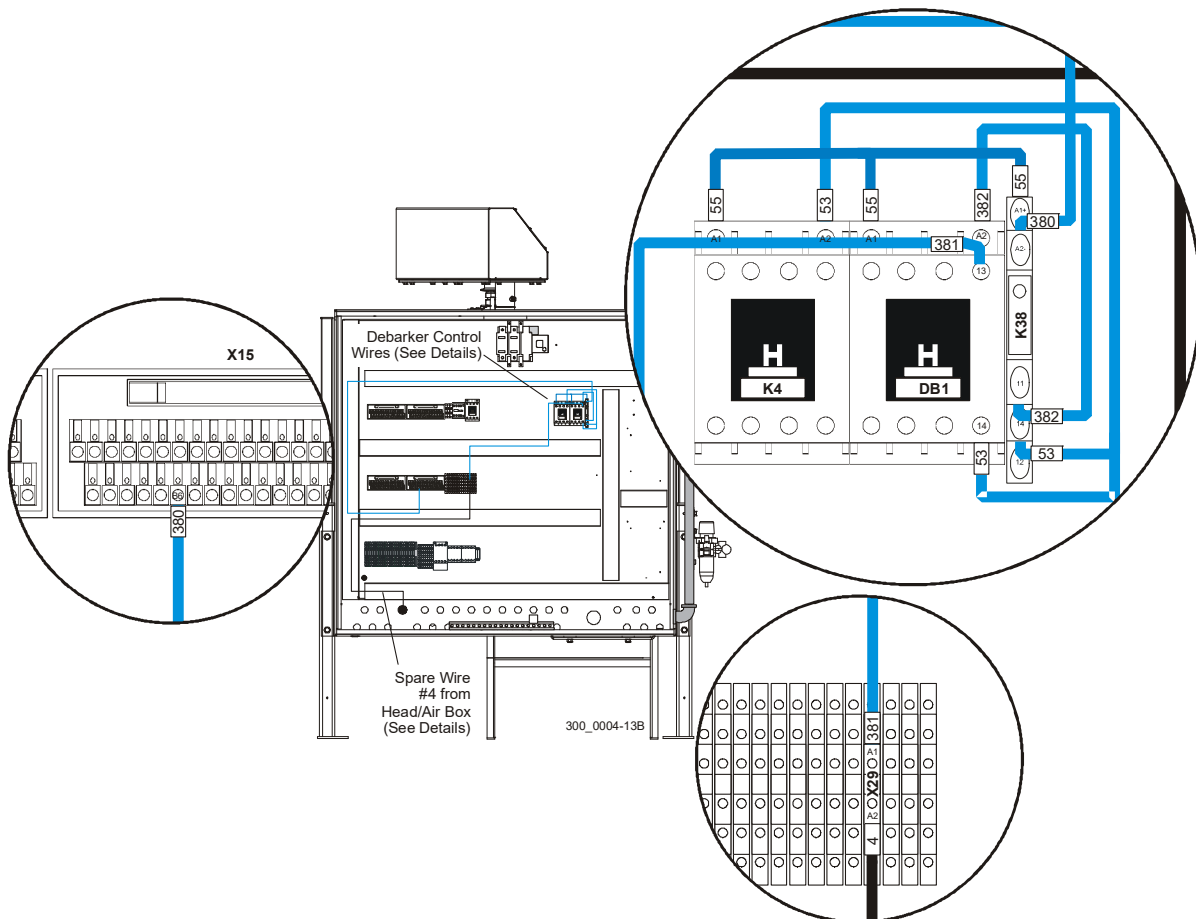

FIG. 2-20

2

Installation

Electrical Installation (LT300 Rev. A1.00 - B2.02 Only)

See Figure 2-21. Connect the supplied DIN cable to the air solenoid valve in the debarker air control box. Route the cable through the side of the saw air box and secure with the cable connector. In the saw air box, connect wire #381 to terminal block X50, terminal A1. Connect wire #68 to terminal block X48, terminal A2.

Locate wire #4 labeled “spare” in the saw air box. Connect wire #4 to terminal block X50, terminal A2.

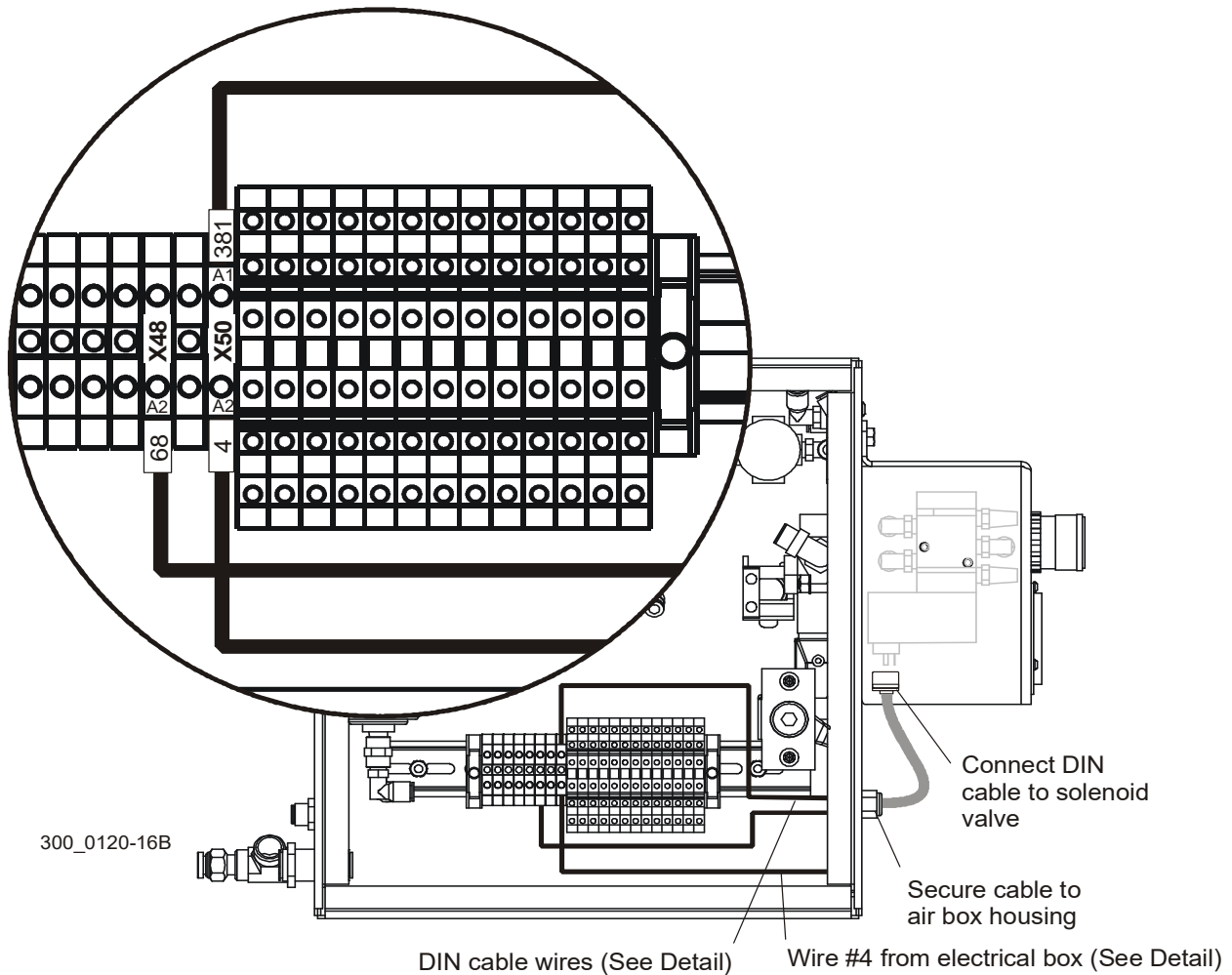

FIG. 2-21

This completes the debarker installation. If, during operation, the debarker moves opposite of proper operation, exchange the position of the air hoses connecting the debarker air cylinder to the valve.

2.6 Electrical Installation (WM4000 Rev. A1.00+ Only)

See **Figure 2-22**. Install the provided manual motor protector (Q4) and contactor (4M1) in the high voltage control box. Remove the rail clamps around the existing components as necessary to make room for the new components. Replace the rail clamps.

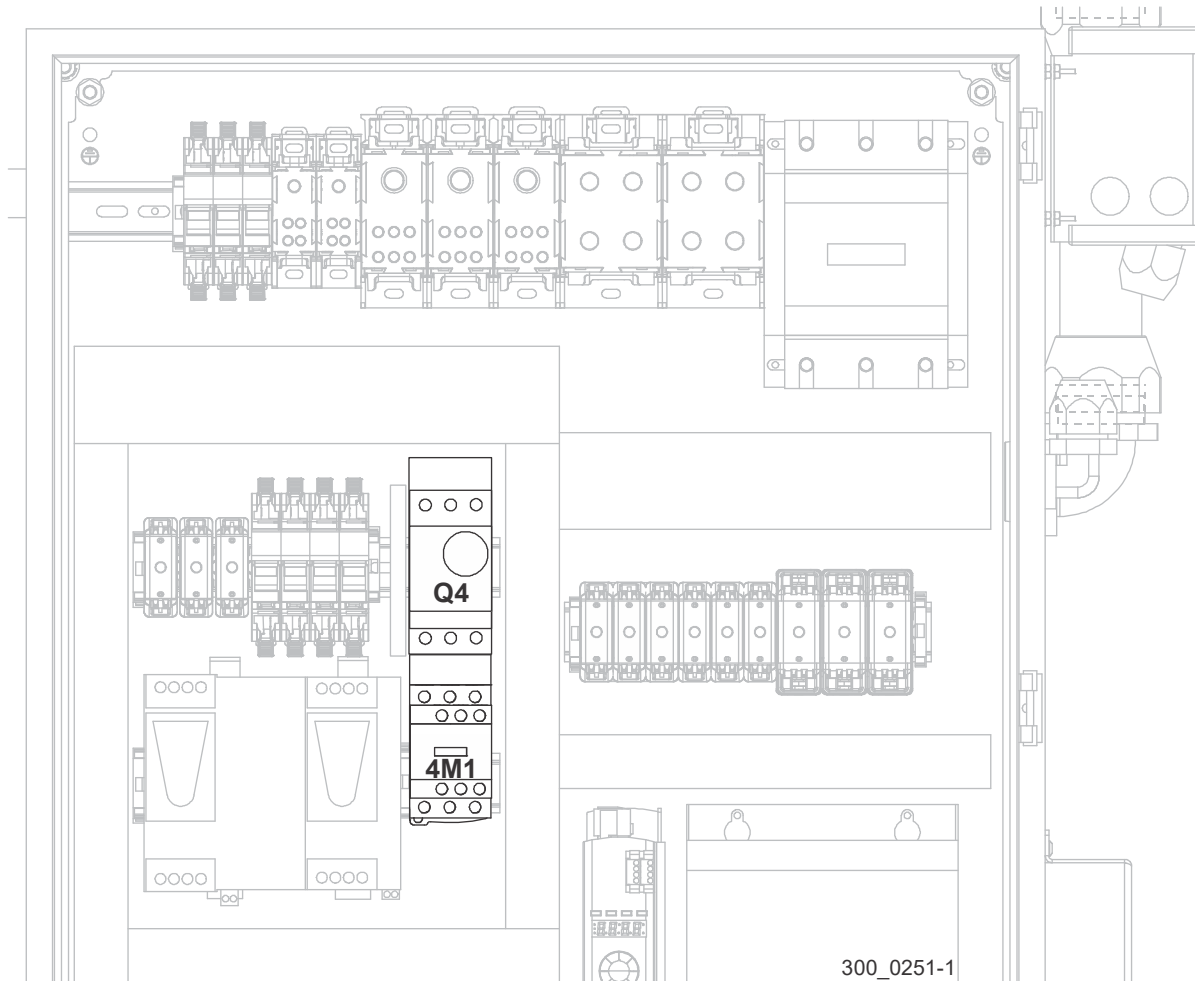

FIG. 2-22

2

Installation

Electrical Installation (WM4000 Rev. A1.00+ Only)

See **Figure 2-23**. Use the wires 2L1, 2L2 and 2L3 to connect the manual motor protector Q4 to the distribution block X1 3-5 as shown below.

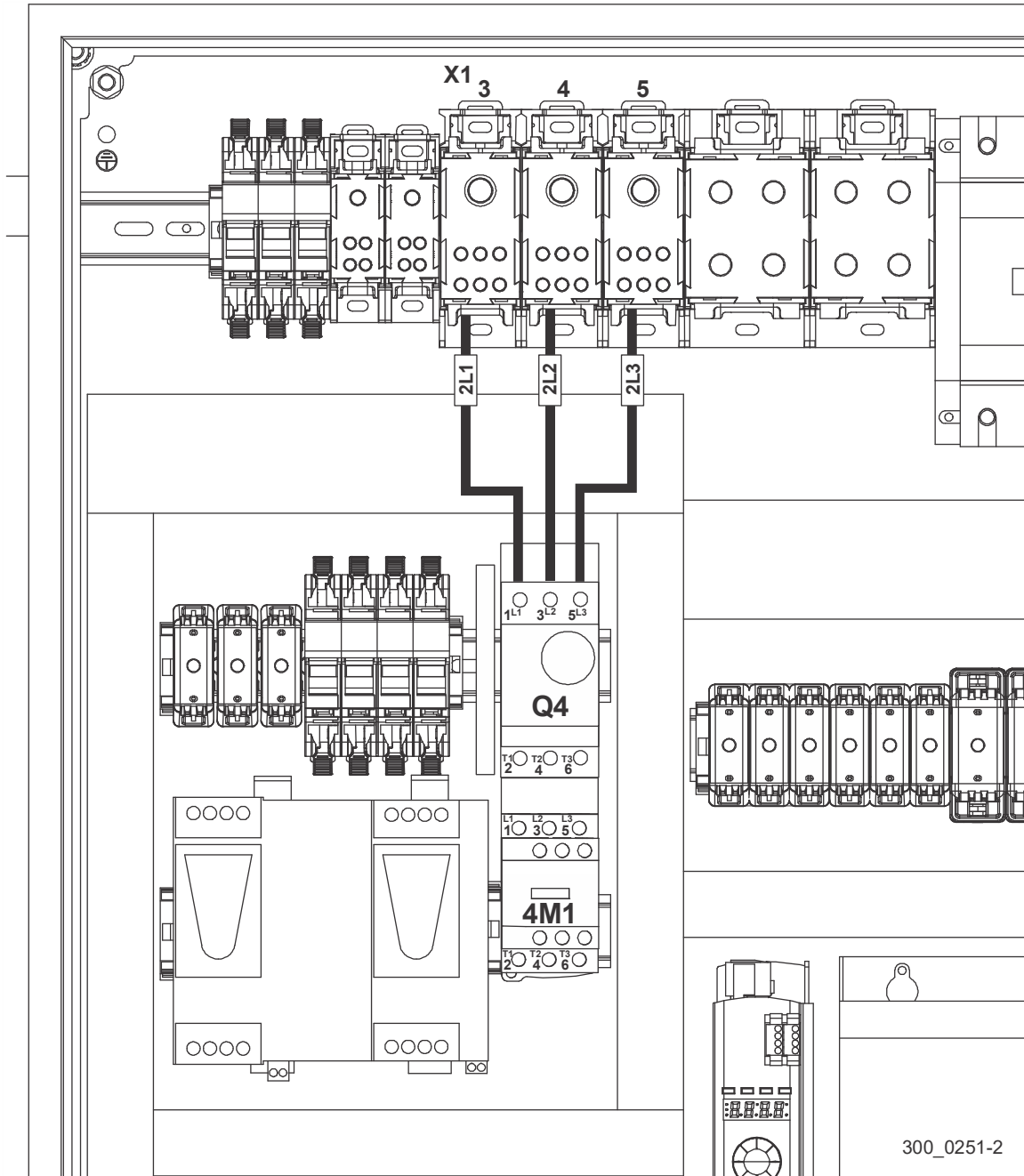

300_0251-2

FIG. 2-23

See Figure 2-24. Install the debarker motor harness to the W6 hole at the bottom of the high voltage control box and secure with the connector provided. Connect the green ground wire to the grounding bar at the bottom of the cabinet. Route wires #448, 449 and 450 to contactor 4M1. Connect wire #448 to terminal T1, wire #449 to terminal T2 and wire #450 to terminal T3 of the contactor 4M1. Route wires #55B and 4023 to terminal block X2. Connect wire #55B to terminal X2-3:2. Connect wire #4023 terminal X2-4:2.

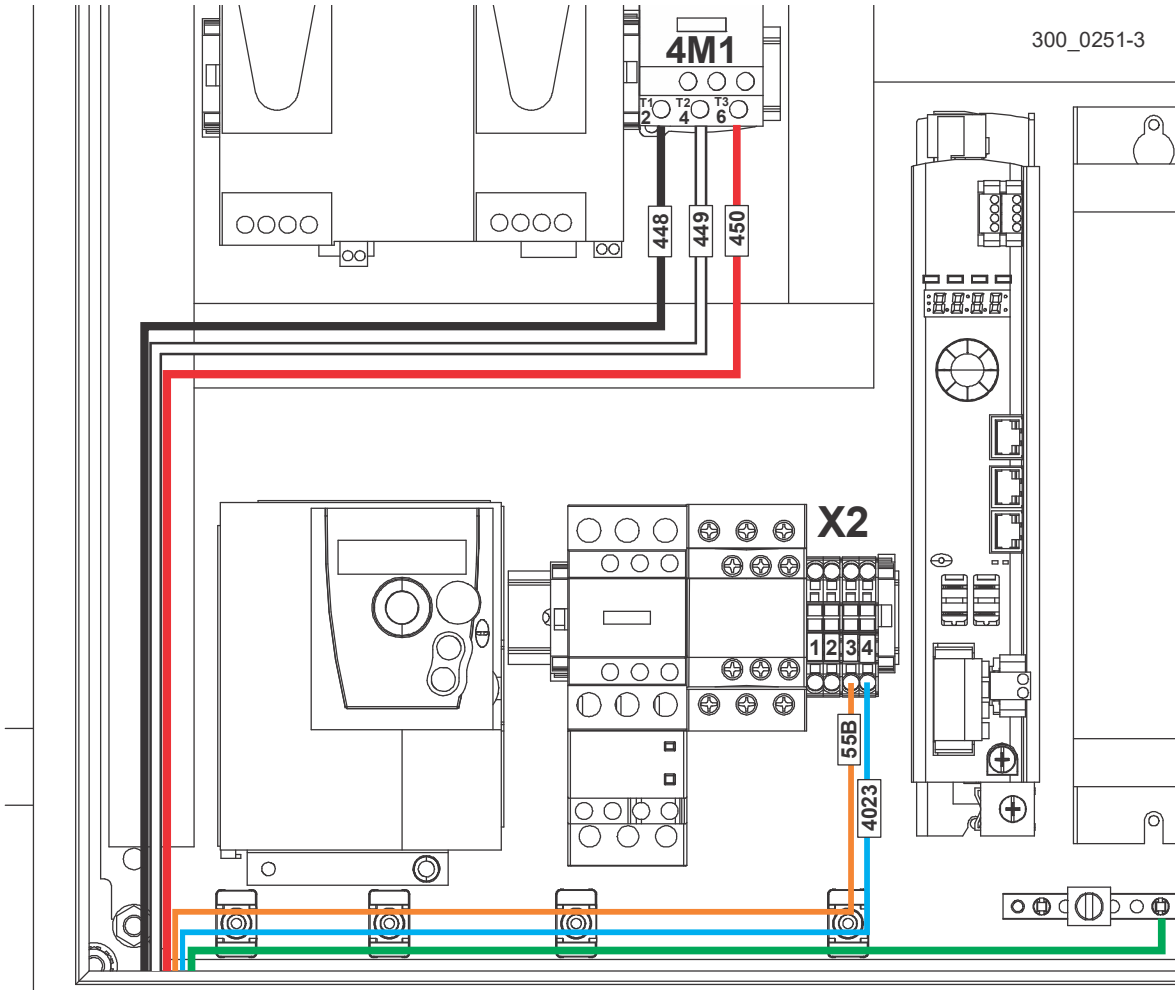

FIG. 2-24

Route the motor harness from the electrical cabinet to the pantograph. Use the supplied strain relief brackets to secure the debarker motor harness to the pantograph. Continue routing the harness underneath the saw motor to the debarker motor. Open the debarker motor terminal housing and use wire nuts to connect wire #21 to debarker wire T1, wire #22 to terminal wire T2, wire #23 to wire T3, wire #55B to wire #1 and wire #4023 to wire #2. Connect motor wire T4 to T7, T5 to T8 and T6 to T9. Connect the green ground wire to the motor ground terminal and replace the terminal housing cover.

2

Installation

Electrical Installation (WM4000 Rev. A1.00+ Only)

See **Figure 2-25**. Connect the supplied DIN cable to the air solenoid valve in the debarker air control box. Route the cable through the side of the saw air box and secure with the cable connector. In the saw air box, connect wire #53A to terminal block X6, terminal 3:3. Connect wire #508 to terminal block X6, terminal 14:2:2. Connect wire #GND to terminal block X6, terminal 1:2.

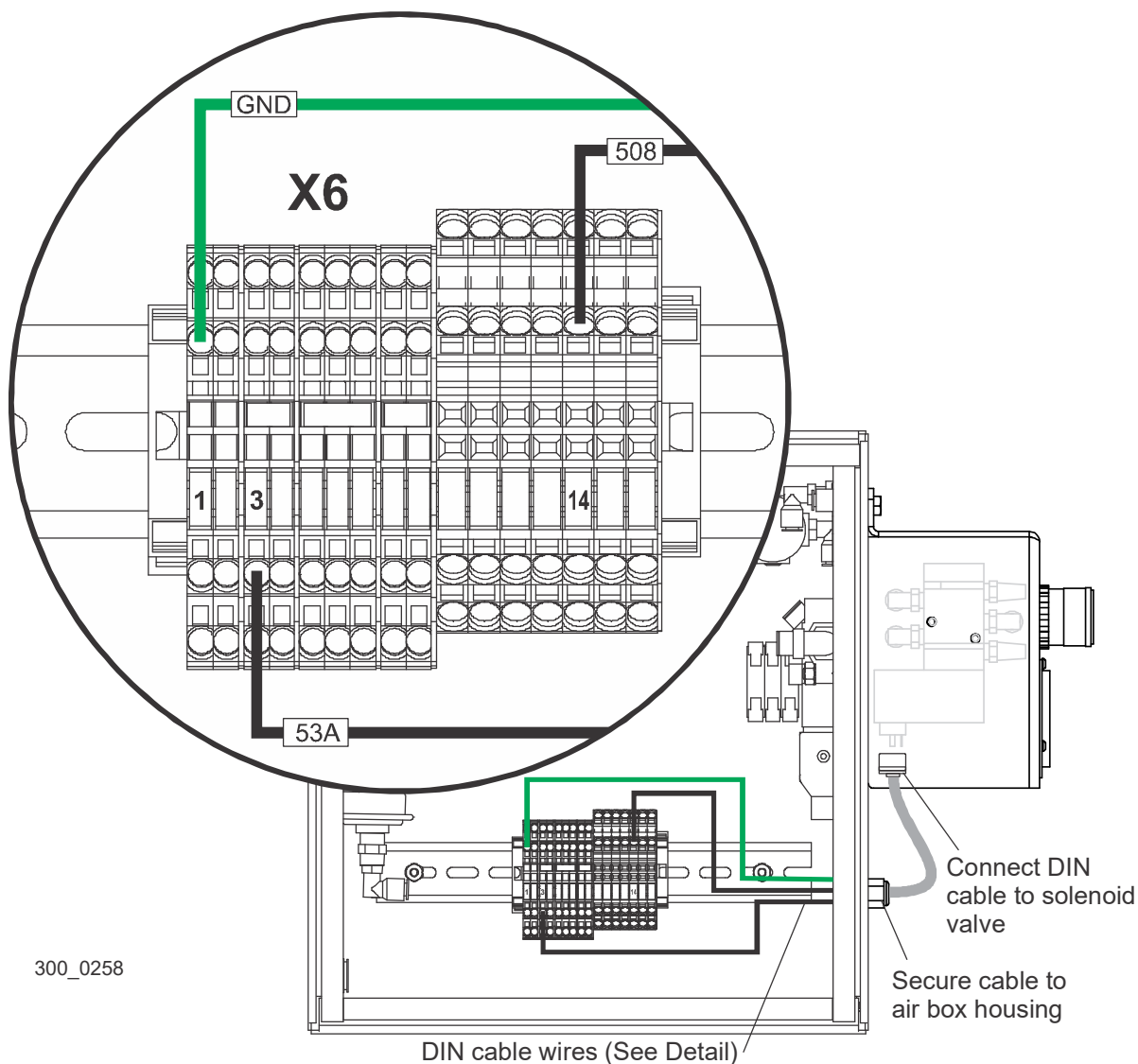

FIG. 2-25

This completes the debarker installation. If, during operation, the debarker moves opposite of proper operation, exchange the position of the air hoses connecting the debarker air cylinder to the valve.

SECTION 3 ALIGNMENT



DANGER! Before performing any service to this equipment, turn the key to the OFF (0) position and remove the key. Failure to do so will result in serious injury or death.

The debarker blade should be aligned to the sawmill blade to insure proper operation. The debarker blade should be parallel with and aligned vertically with the sawmill blade.

1. Use the debarker foot switch to move the debarker all the way in. Turn off and lockout power to the sawmill. This will prevent the debarker from being turned on while performing alignment procedures.
2. Check the squareness of the debarker with the sawmill blade. Adjust the debarker mounts if necessary until the debarker is square with the sawmill blade.

Loosen the bottom debarker mounting bolt and loosen the jam nuts on the adjustment bolts. Turn the adjustment bolts as necessary until the debarker is square with the sawmill blade. Retighten the jam nuts and bottom debarker mounting bolt.

See Figure 3-1.

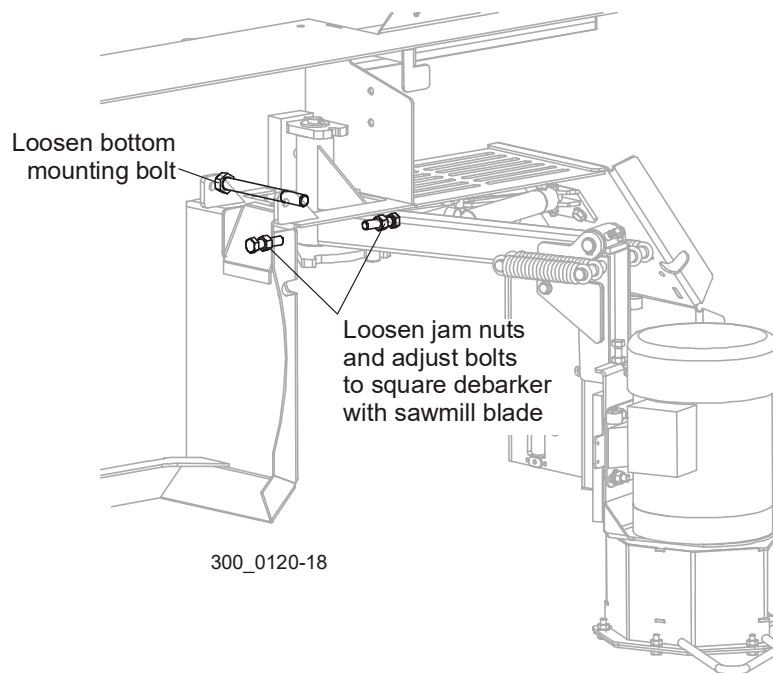

FIG. 3-1

3

Alignment

3. Clip the blade guide alignment tool to the sawmill blade. Make sure the tool lies flat on the blade and does not contact a tooth that could cause it to angle.

See Figure 3-2.

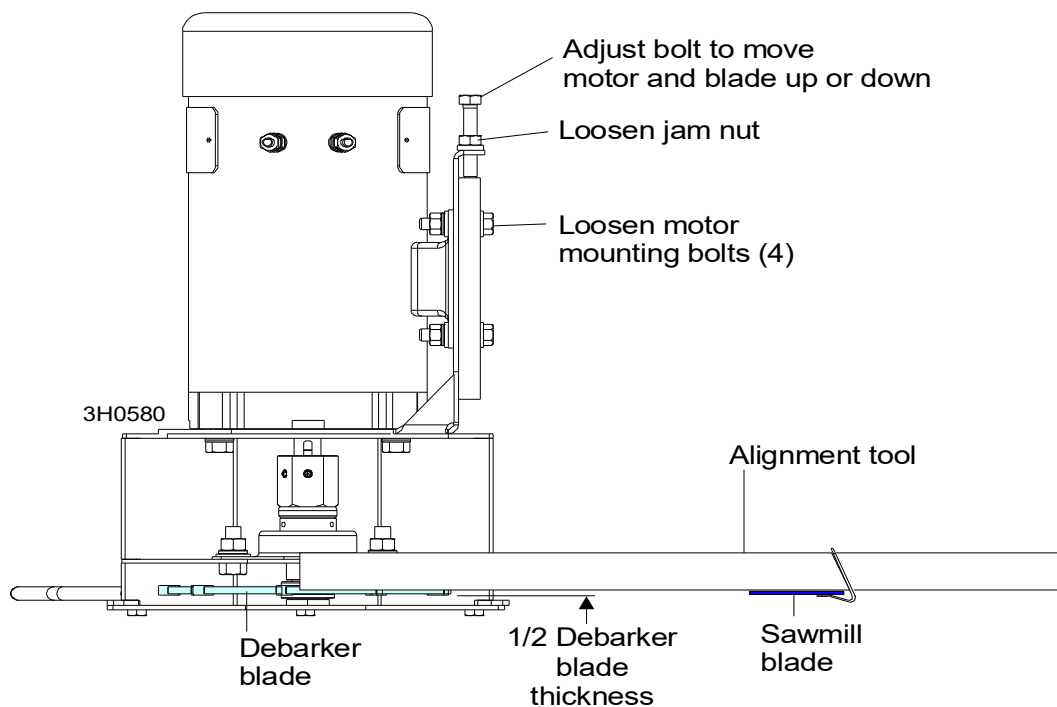

FIG. 3-2

4. Check the height of the debarker blade against the alignment tool. The bottom edge of the tool should align with the center of the debarker blade.
5. To adjust the blade up or down, loosen the four blade motor mount bolts. Loosen the jam nuts on the adjustment bolts. Turn the adjustment bolts clockwise to push the motor and blade down. Turn the adjustment bolts counterclockwise and slide the motor up to raise the motor and blade. Retighten the adjustment bolt jam nuts and four motor mount bolts.
6. Insert the key and use the debarker in/out switch to move the debarker all the way out. Turn the key to OFF (0) and remove the key.
7. Move the blade guide alignment tool on the sawmill blade and check the position of the debarker blade against the tool. If the debarker blade is not centered with the tool, readjust the debarker mounting bolts to adjust the debarker assembly parallel to the blade.

8. If the debarker blade tends to climb during use, this indicates the blade is tilted up. Remove the shim located at the pivot arm stop to tilt the debarker blade down. Remove the two stop block mounting screws, remove the shim and replace the stop block and mounting screws.

See Figure 3-3.

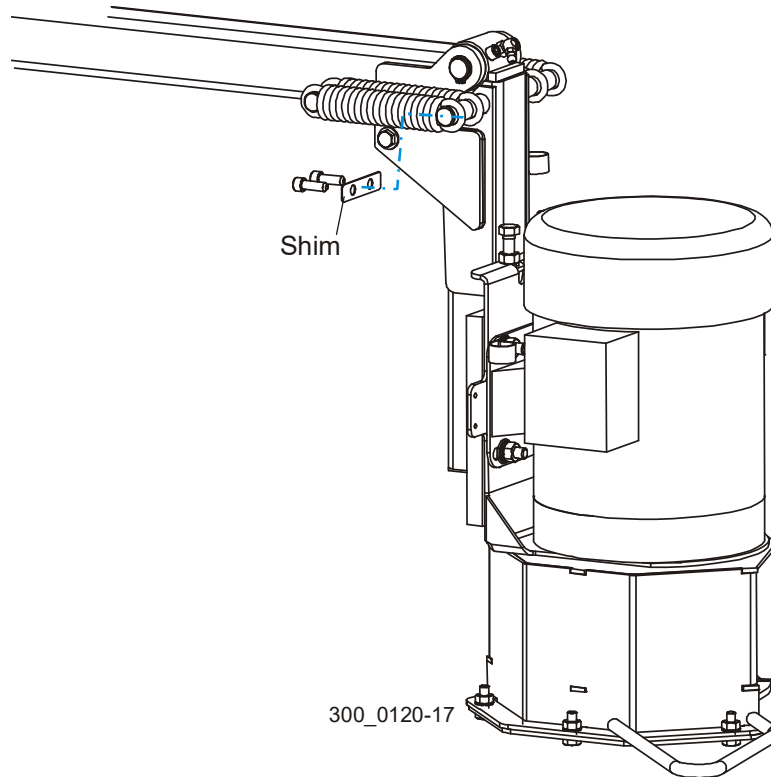

FIG. 3-3

SECTION 4 OPERATION

LT300/WM3000/WM3500 Only

Use the foot switch to operate the debarker option. Push and hold the switch to activate the air cylinder to pivot the debarker blade against the log.

NOTE: The sawmill motor must be on and the feed activated in the forward direction for the debarker option to be operational.

At the end of the cut, release the foot switch to pivot the debarker away from log.

WM4000 Only

See Figure 4-1. Press the rear switch of the left joystick to change to HEAD mode. Press the bottom head button to start the debarker operation.

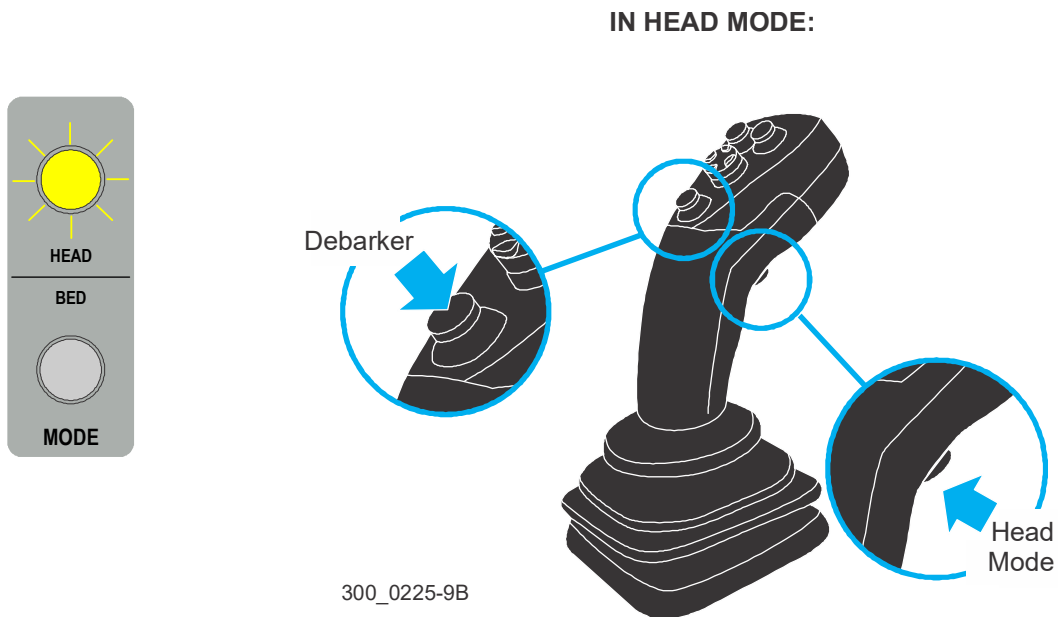

FIG. 4-1

SECTION 5 MAINTENANCE

Lubricate the pivot joint with a NLGI #2 grade lithium grease every 40 hours of operation.

See Figure 5-1.

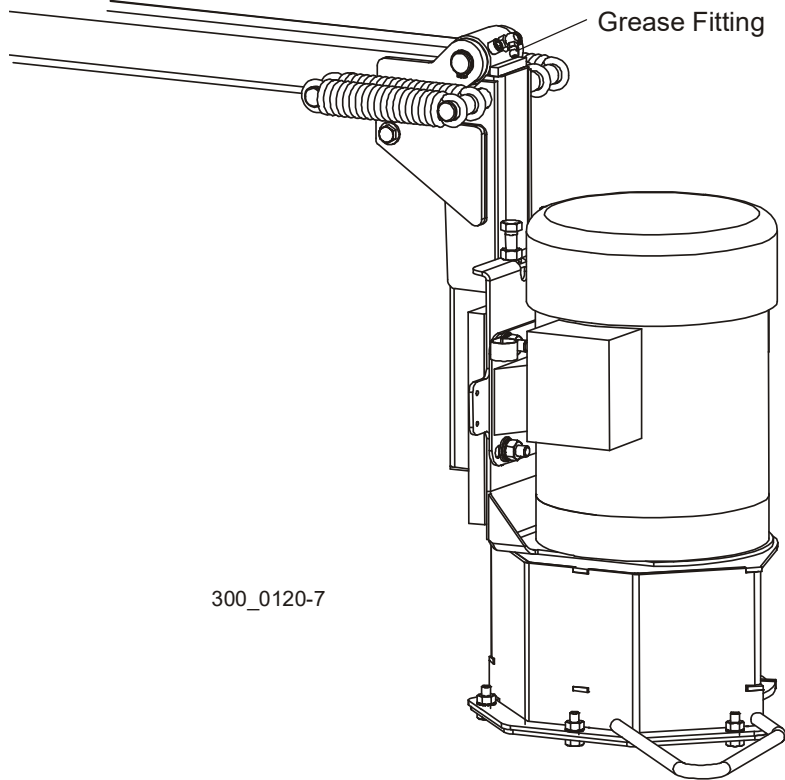

FIG. 5-1

Periodically check the debarker blade. Align or replace as needed.



WARNING! Before replacing the debarker blade, move the sawmill blade guide arm in front of the sawmill blade to cover the blade teeth. Failure to do so may result in serious injury or death.

To replace the debarker blade, remove the lower blade guard plate. Place one wrench on the blade arbor, above the blade bearing. Place the other wrench on the lower bolt and rotate clockwise (bolt has left-hand threads). Remove the bolt and washer. Remove the blade and spacer.

Reinstall the spacer with the new blade. Reinstall the bolt and washer and turn counter-clockwise to tighten to 35 foot-pounds (± 5). Reinstall the blade guard plate.



CAUTION! Tighten the blade bolt manually. Using power-assisted tools may result in over-torquing and damage to the bolt.

SECTION 6 REPLACEMENT PARTS

6.1 Debarker (Complete)

LT300/WM3000/WM3500 Rev. B3.00+
 WM4000 Rev. A1.00+

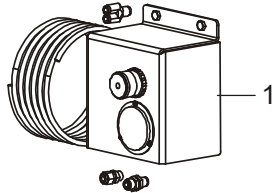

300_0120-20

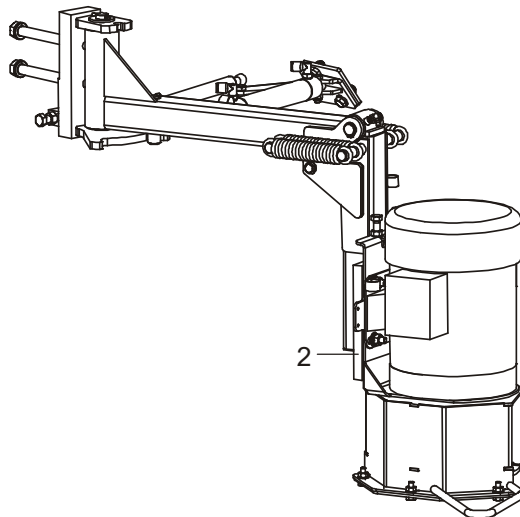

REF	DESCRIPTION (◆ Indicates Parts Available In Assemblies Only)	PART #	QTY.
	DEBARKER KIT, LT300 FIELD INSTALLED (LT300/WM3000 w/o Pantograph Cable Boom)	003984	1
	DEBARKER KIT, LT300 FIELD INSTALLED (LT300/WM3000 w/Pantograph Cable Boom)	006804	1
	DEBARKER KIT, WM3500 FIELD INSTALLED (WM3500 w/Pantograph Cable Boom)	008762	1
	DEBARKER KIT, WM4000 FIELD INSTALLED (WM4000 w/Pantograph Cable Boom)	074060	1
1	Air Box Parts (See Section 6.7)		
2	Debarker Parts (See Section 6.3)		
	Electrical Components (LT300/WM3000/WM3500) (See Section 7.7)		
	Electrical Components (WM4000) (See Section 7.7)		
	Harness Assembly, Debarker Motor (LT300/WM3000 w/o Pantograph Cable Boom)	052786	1
	Harness Assembly, Debarker Motor (LT300/WM3000-BX6 w/o Pantograph Cable Boom)	052786-BX	1
	Harness Assembly, Debarker Motor (LT300/WM3000/WM3500 w/Pantograph Cable Boom)	052786-P	1
	Harness Assembly, Debarker Motor (WM4000 w/Pantograph Cable Boom)	069959	1
	Cable Assembly, Debarker Air Solenoid (LT300/WM3000/WM3500)	052785	1
	Cable Assembly, Debarker Air Solenoid (WM4000)	069979	1
	Strain Relief, CFX 12-14mm Single Cable	065978	6

6 Replacement Parts

Debarker (Complete)

6.2 Debarker (Complete)

LT300 Rev. A1.00 - B2.02

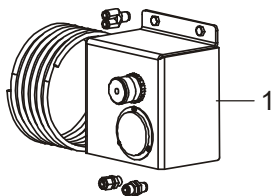

300_0120-1

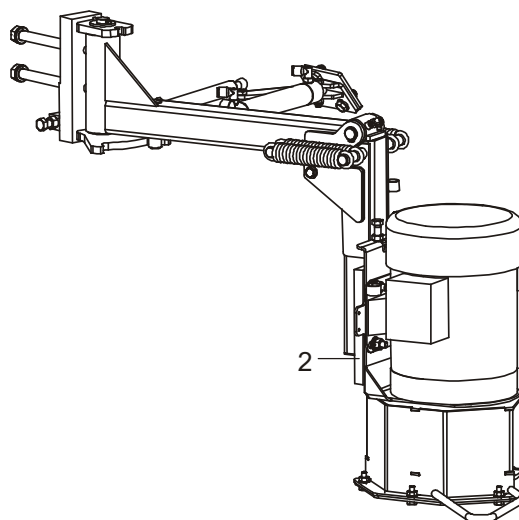

REF	DESCRIPTION (◆ Indicates Parts Available In Assemblies Only)	PART #	QTY.
	DEBARKER KIT, LT300 FIELD INSTALLED (LT300 w/o Pantograph Cable Boom)	038771	1
	DEBARKER KIT, LT300 FIELD INSTALLED (LT300 w/Pantograph Cable Boom)	006805	1
1	Air Box Parts (See Section 6.7)		
2	Debarker Parts (See Section 6.3)		
	Electrical Components (See Section 7.9)		
	Harness Assembly, Debarker Motor (LT300 w/o Pantograph Cable Boom)	052786	1
	Harness Assembly, Debarker Motor (LT300 w/Pantograph Cable Boom)	052786-P	1
	Cable Assembly, Debarker Air Solenoid	052785	1

6.3 Debarker

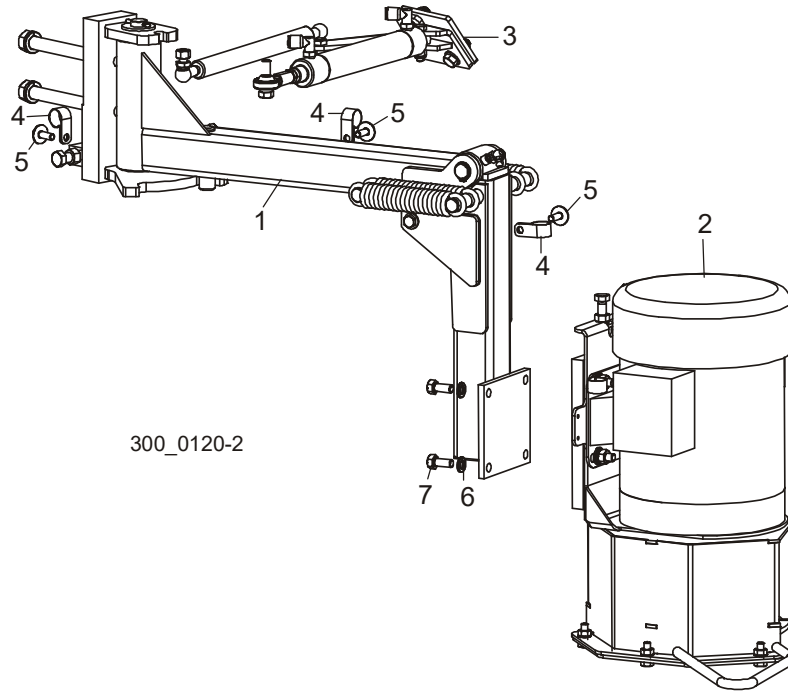

REF	DESCRIPTION (◆ Indicates Parts Available In Assemblies Only)	PART #	QTY.
	DEBARKER ASSEMBLY, LT300/WM3000	037610	1
	DEBARKER ASSEMBLY, WM3500/WM4000	008763	1
1	Swing Arm Parts (See Section 6.4)		
2	Cutting Head Parts (See Section 6.5)		
3	Pivot Arm Parts (See Section 6.6)		
4	Clamp, 5/8" EMT Coated	010748	3
5	Bolt, 1/4-20 x 3/4" Hex Head w/Conical Washer	F05005-134	3
6	Washer, 5/16" Split Lock	F05011-13	4
7	Bolt, 5/16-18 x 3/4" Hex Head	F05006-5	4

6 Replacement Parts

Swing Arm Assembly

6.4 Swing Arm Assembly

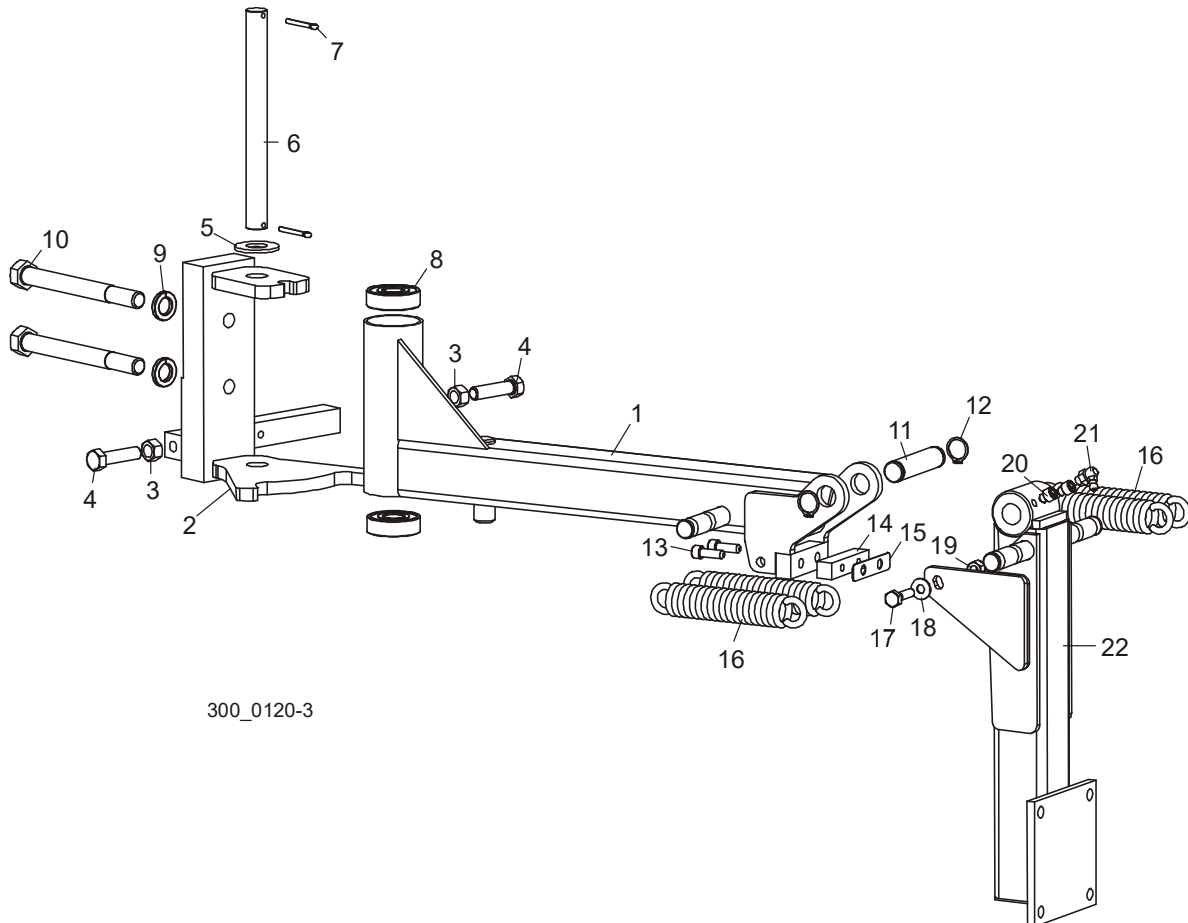

300_0120-3

REF	DESCRIPTION (◆ Indicates Parts Available In Assemblies Only)	PART #	QTY.
	ARM ASSEMBLY, LT300/WM3000 DEBARKER SWING	037612	1
	ARM ASSEMBLY, WM3500 DEBARKER SWING	008767	1
	Arm Assembly, LT300/WM3000 Debarker Upper	037615	1
	Arm Assembly, WM3500 Debarker Upper	008764	1
1	Arm Weldment, Debarker Upper	037616	1
2	Mount Weldment, LT300/WM3000 Debarker Arm	037617	1
	Mount Weldment, WM3500 Debarker Arm	059586	1
3	Nut, 3/8-16 Hex	F05010-1	2
4	Bolt, 3/8-16 x 1 1/2" Hex Head Full Thread (LT300/WM3000)	F05007-17	2
	Bolt, 3/8-16 x 2" Hex Head Full Thread (WM3500)	F05007-16	2
5	Washer, 5/8" SAE Flat	F05011-5	1
6	Pin, 5/8" Dia. x 6 9/16" Long Pivot	046034	1
7	Pin, 1/8" x 1" Cotter	F05012-1	2
8	Bearing 5/8" ID x 1.7548" OD x .4724" Thick	P06030-1	2
9	Washer, 1/2" Split Lock	F05011-9	2

Replacement Parts 6

Swing Arm Assembly

10	Bolt, 1/2-13 x 5" Hex Head Grade 5	F05008-66	2	
11	Pin, Pivot	023646	1	
12	Ring, 5/8" Outside Retaining	F04254-2	2	
13	Screw, 1/4-20 x 3/4" Socket Head	F05005-26	2	
14	Bar, Pivot Stop	046044	1	
15	Shim, Pivot Stop	046045	1	
16	Spring, Debarker Arm	021185	4	
17	Bolt, 1/4-20 x 1" Hex Head	F05005-38	1	
18	Washer, 1/4" SAE Flat	F05011-11	1	
19	Nut, 1/4-20 Hex Nylon Lock	F05010-69	1	
20	Screw, 1/4-28 x 1 1/4" Socket Head	F05005-106	2	
21	Fitting, 1/4-28 90° Grease	P04108	1	
22	Arm Weldment, Debarker Lower Swing	037613	1	

6 Replacement Parts

Cutting Head Assembly

6.5 Cutting Head Assembly

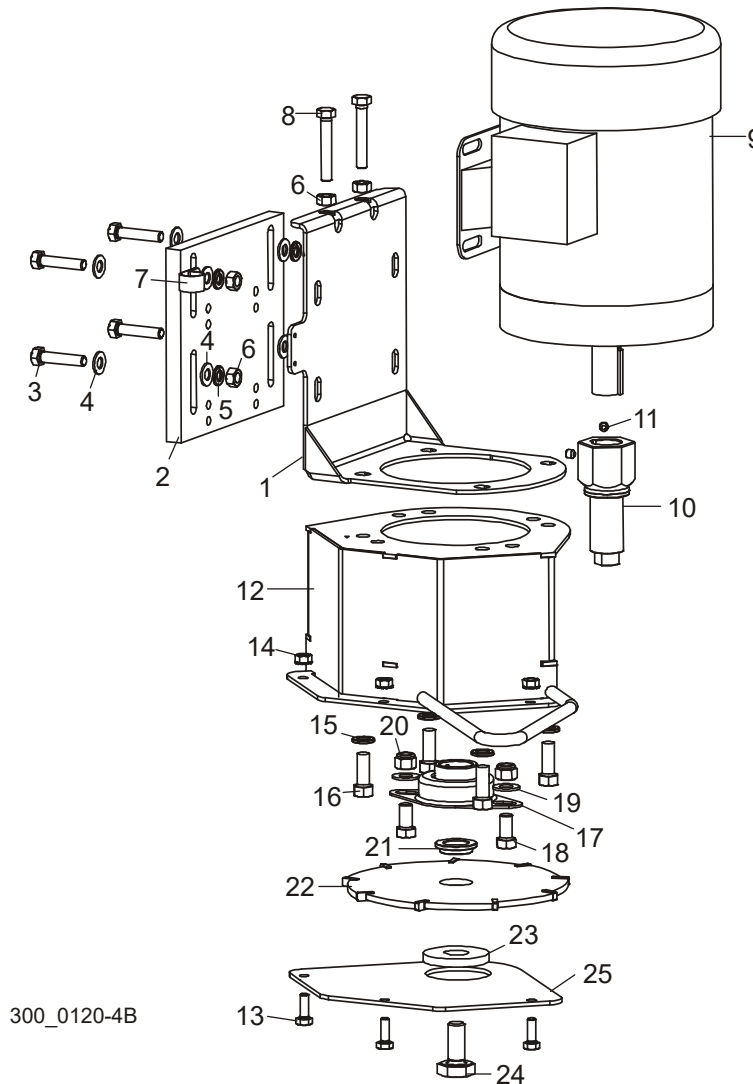

300_0120-4B

REF	DESCRIPTION (◆ Indicates Parts Available In Assemblies Only)	PART #	QTY.
	HEAD ASSEMBLY, DEBARKER CUTTING	037611	1
1	Bracket Weldment, Debarker Tensioner	023622	1
2	Plate, Aluminum Motor Mount	023620	1
3	Bolt, 5/16-18 x 1 1/2" Hex Head Full Thread	F05006-2	4
4	Washer, 5/16" SAE Flat	F05011-17	8
5	Washer, 5/16" Split Lock	F05011-13	4
6	Nut, 5/16-18 Hex	F05010-17	6
7	Clamp, 5/8" EMT Coated	010748	1
8	Bolt, 5/16-18 x 2" Hex Head Full Thread	F05006-13	2
9	Motor, 3/4 HP 230/460V 3P 1725 RPM	050292	1

10	Mandrel, 7/8" Machined Debarker Blade	016122	1	
11	Screw, 1/4-28 x 1/4" Cup Point Socket Set	F05005-105	2	
12	Guard Weldment, Debarker Cutter Head	023628	1	
13	Bolt, 1/4-20 x 3/4" Hex Head Full Thread	F05005-1	3	
14	Nut, 1/4-20 Hex Self-Retaining	F05010-9	3	
15	Washer, 3/8" Split Lock	F05011-4	4	
16	Bolt, 3/8-16 x 1" Hex Head	F05007-7	4	
17	Bearing, 1" Flanged Mount	023541	1	
18	Bolt, 3/8-16 x 3/4" Hex Head	F05007-27	2	
19	Washer, 3/8" SAE Flat	F05011-3	2	
20	Nut, 3/8-16 Hex Nylon Lock	F05010-10	2	
21	Bushing, Blade Spacer	023632	1	
22	Blade, 7" Debarker	021236	1	
	Blade, 7" Debarker w/1/2" Inserts (Optional - Purchased Separately)	065852	1	
23	Washer, Blade Lock	023737	1	
24	Bolt, 1/2-20 x 1 1/4" Hex Head Left-Hand Threads	023547	1	
25	Plate, Debarker Bottom Guard	023629	1	

6.6 Debarker Blade Drive Assembly

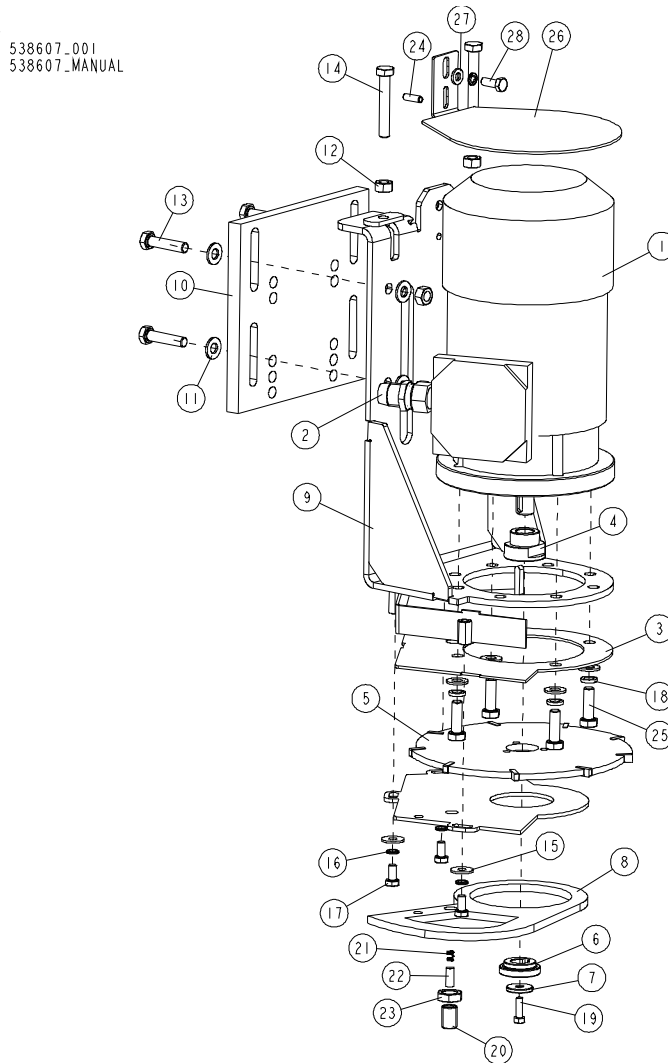

REF.	DESCRIPTION (* Indicates Parts Available in Assemblies Only)	PART #	QTY
-	DRIVE ASSEMBLY, DEBARKER BLADE	538607	1
1	MOTOR, STKG71X-2C IMB5 AC DEBARKER	096777	1
2	GLAND, DW11/H CABLE	085388	1
3	GUARD, DEBARKER BLADE UPPER	096244-1	1
4	BUSHING, DEBARKER BLADE CLAMP	096088	1
5	BLADE, 180 B-06.5/5.0 D-25.5 COMPLETE	083848-1	1
6	BUSHING, DEBARKER BLADE RETAINING	096087	1
7	WASHER	096238-1	1
8	GUARD, DEBARKER BLADE LOWER	096245-1	1
9	BRACKET, DEBARKER MOTOR	538605-1	1

REF.	DESCRIPTION (* Indicates Parts Available In Assemblies Only)	PART #	QTY
10	PLATE, DEBARKER MOTOR MOUNT	089551	1
11	WASHER, 8.4 FLAT ZINC	F81054-1	12
12	NUT, M8-8-B HEX ZINC	F81032-1	6
13	BOLT, M8X35-8.8 HEX HEAD FULL THREAD ZINC	F81002-13	4
14	BOLT, M8X50-8.8 HEX HEAD FULL THREAD ZINC	F81002-19	2
15	WASHER, 6.5 SPECIAL FLAT ZINC	F81053-11	3
16	WASHER, Z 6.1 SPLIT LOCK ZINC	F81053-3	4
17	BOLT, M6X12 8.8 HEX HEAD FULL THREAD ZINC	F81001-7	3
18	WASHER, 8.2 SPLIT LOCK ZINC	F81054-4	4
19	BOLT, M5x16-8.8 HEX HEAD FULL THREAD ZINC	F81000-20	1
-	PIN ASSEMBLY, DEBARKER BLADE BRAKING	501464	1
20	SCREW, BLADE BRAKE SET	501462	1
21	SPRING, 0.5X5.5-7	501463	1
22	PIN, DEBARKER BLADE BRAKING	501461	1
23	NUT, M12-04-A THIN	F81034-6	1
24	PIN, 5X16 ROLL ZINC	F81044-3	1
25	BOLT, M8X25-8.8-B HEX HEAD FULL THREAD ZINC	F81002-5	4
26	GUARD, DEBARKER MOTOR	538610-1	1
27	WASHER, 6.4 FLAT ZINC	F81053-1	1
28	BOLT, M6X16-8.8 HEX HEAD FULL THREAD ZINC	F81001-15	1

6 Replacement Parts

Pivot Arm Assembly

6.6 Pivot Arm Assembly

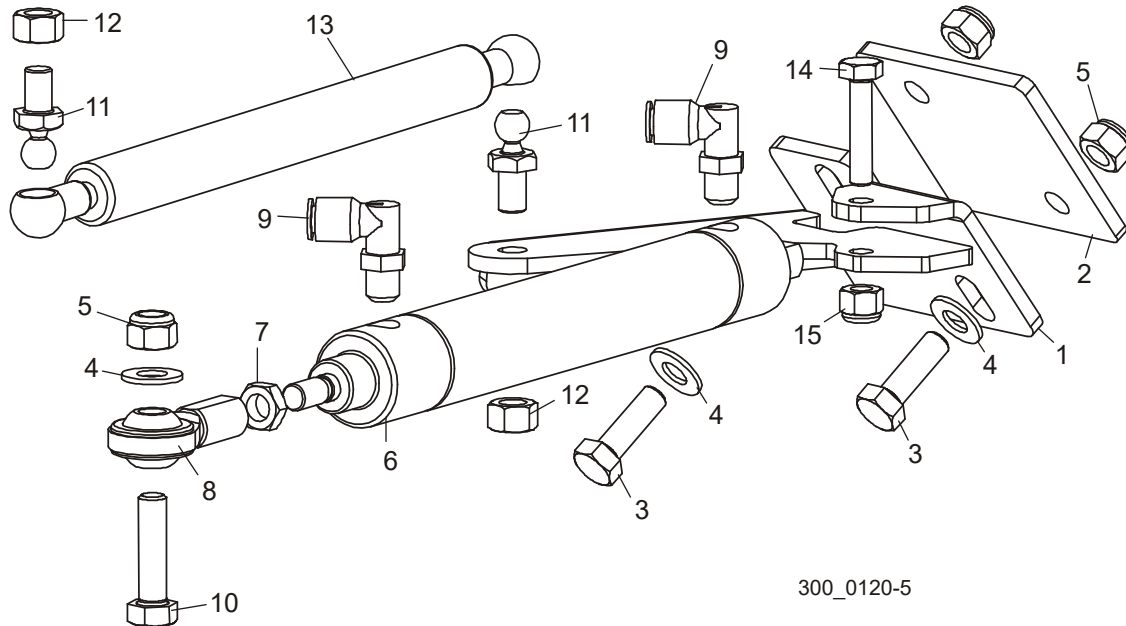

REF	DESCRIPTION (◆ Indicates Parts Available In Assemblies Only)	PART #	QTY.
1	ARM WELDMENT, LT300/WM3000 DEBARKER PIVOT	037606	1
	ARM WELDMENT, WM3500 DEBARKER PIVOT	059588	1
2	PLATE, PIVOT ARM MOUNT	038714	1
3	BOLT, 5/16-18 X 1" HEX HEAD GRADE 5	F05006-27	2
4	WASHER, 5/16" SAE FLAT	F05011-17	3
5	NUT, 5/16-18 HEX NYLON LOCK	F05010-58	3
6	CYLINDER ASSEMBLY, LT300/WM3000 DEBARKER AIR	037608	1
	CYLINDER ASSEMBLY, WM3500 DEBARKER AIR	008765	1
6	Cylinder, 1 1/16" Bore x 5" Stroke Air (LT300/WM3000)	037607	1
	Cylinder, 1 1/16" Bore x 6" Stroke Air (WM3500)	008766	1
7	Nut, 5/16-24 Hex Jam	F05010-119	1
8	Rod, 5/16-24 Female End	P09813	1
9	Fitting, 1/8" MPT x 1/4" Tube 90° Swivel Elbow	P09736	2
10	BOLT, 5/16-18 X 1 1/4" HEX HEAD FULL THREAD GRADE 5	F05006-93	1
11	BALL-END, 10MM X 5/16-18 X .41" STEEL	037364	2
12	NUT, 5/16-18 HEX LOCK	F05010-6	2
13	ROD, HAND CONTROL DAMPENER	044570	1
14	BOLT, 1/4-20 X 1 1/4" HEX HEAD GRADE 5	F05005-116	1
15	NUT, 1/4-20 HEX NYLON LOCK	F05010-69	1

6.7 Air Box Assembly

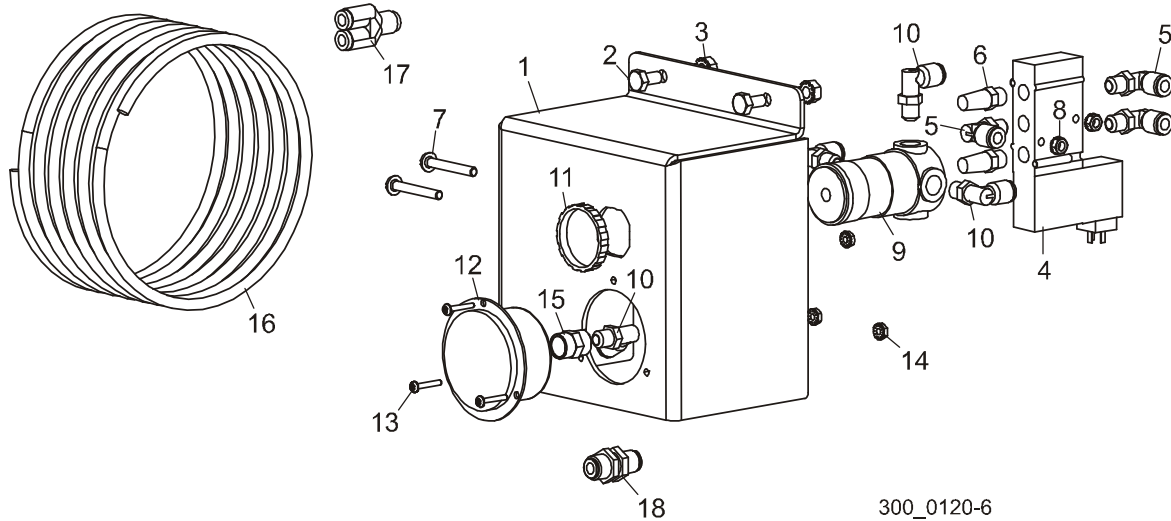

300_0120-6

REF	DESCRIPTION (◆ Indicates Parts Available In Assemblies Only)	PART #	QTY.
	BOX ASSEMBLY, DEBARKER AIR	037625	1
1	Box, Debarker Air	037622	1
2	Bolt, 1/4-20 x 1/2" Hex Head	F05005-15	2
3	Nut, 1/4-20 Self-Locking Hex	F05010-9	2
4	Valve Assembly, Debarker Air	037624	1
5	Valve, Mac 400 Series Air	025244	1
6	Fitting, 1/8" MPT x 1/4" Tube 90° Swivel Elbow	P09736	3
7	Muffler, 1/8" NPT Air	P20902	2
8	Screw, #8-32 x 1 1/2" Slotted Round Head	F05004-71	2
9	Nut, #8-32 Self-Locking Hex	F05010-41	2
10	Regulator, 1/8" NPT Air	052509	1
11	Fitting, 1/8" MPT x 1/4" Tube 90° Swivel Elbow	P09736	4
12	Nut, Regulator Mount	052510	1
13	Gauge, Air Pressure	042342	1
14	Screw, #6-32 x 3/4" Socket Button Head Stainless Steel	F05004-93	3
15	Nut, #6-32 Self-Locking Hex	F05010-59	3
16	Fitting, 1/8" FPT Coupling	P05748	1
17	Tubing, 1/4" Dia. x 13'-9" Chainflex Air	037635	1
18	Fitting, 1/4" Tube 'Y'	042546	1
	Fitting, 1/4" Tube Bulkhead	025234	1

SECTION 7 ELECTRICAL INFORMATION

7.1 Schematic (LT300/WM3000/WM3500 Rev. B3.00+ Only)

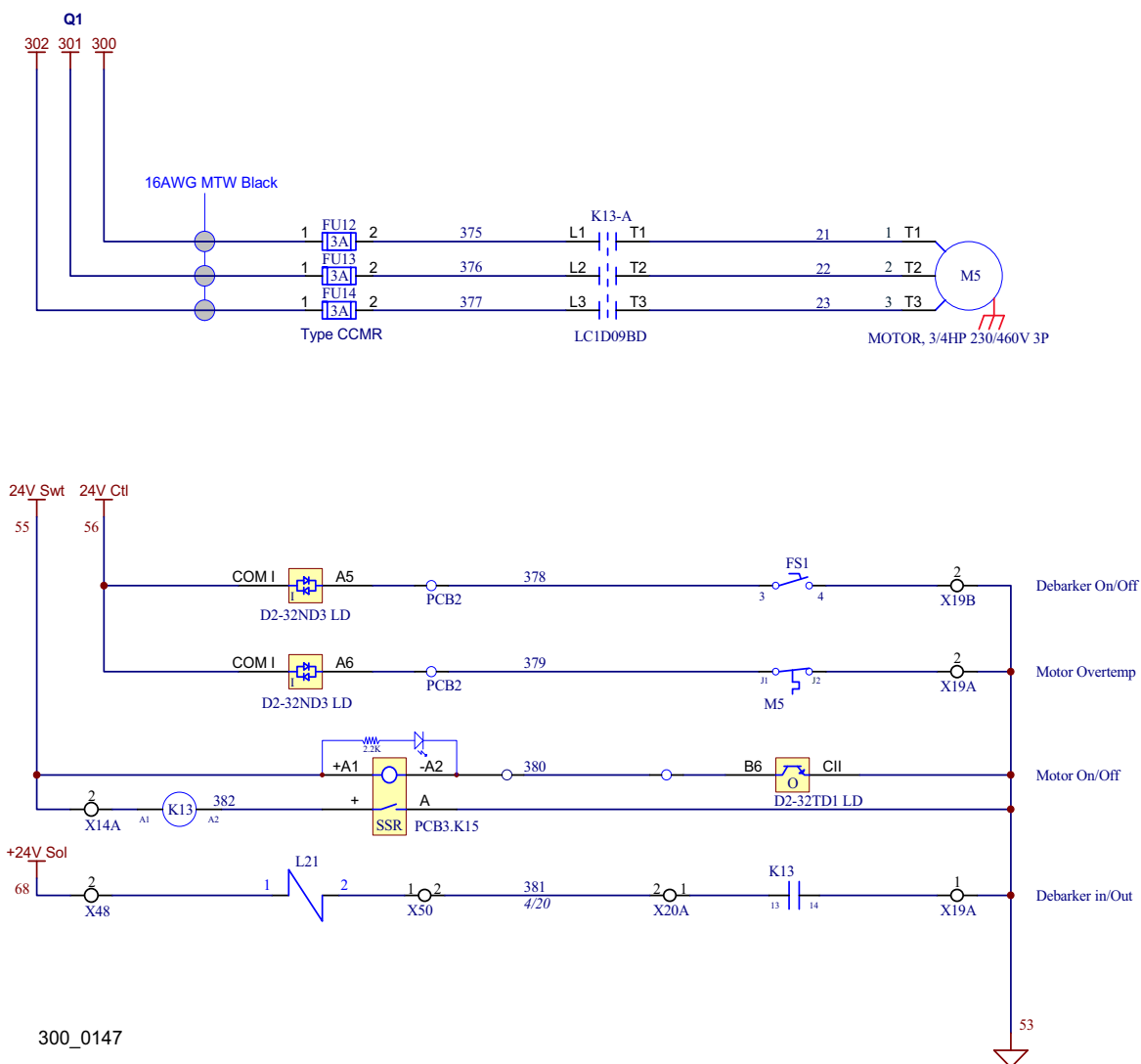

7.2 Schematic (WM4000 Rev. A1.00+ Only)

See *Form #2018 WM4000 Electrical Information* for Debarker Option schematics.

7.3 Schematic (LT300 Rev. A1.00 - B2.02 Only)

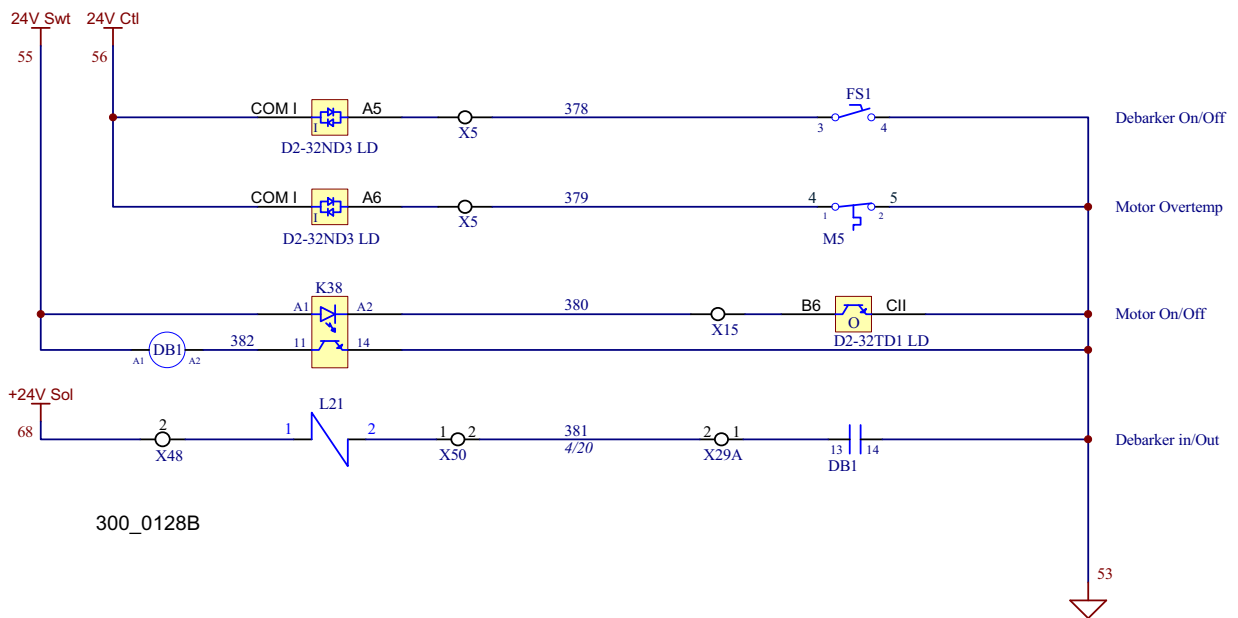
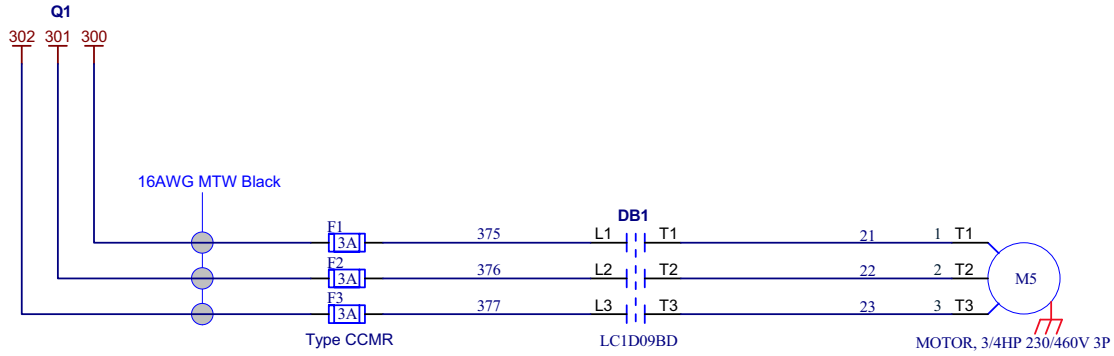

7 Electrical Information

Control Layout (LT300/WM3000/WM3500 Rev. B3.00+ Only)

7.4 Control Layout (LT300/WM3000/WM3500 Rev. B3.00+ Only)

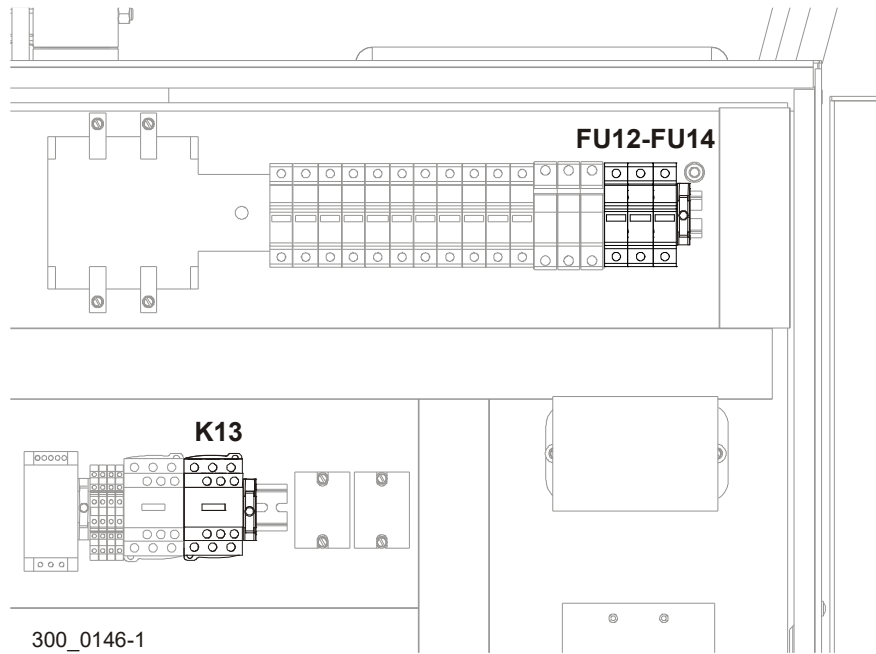

7.5 Control Layout (WM4000 Rev. A1.00+ Only)

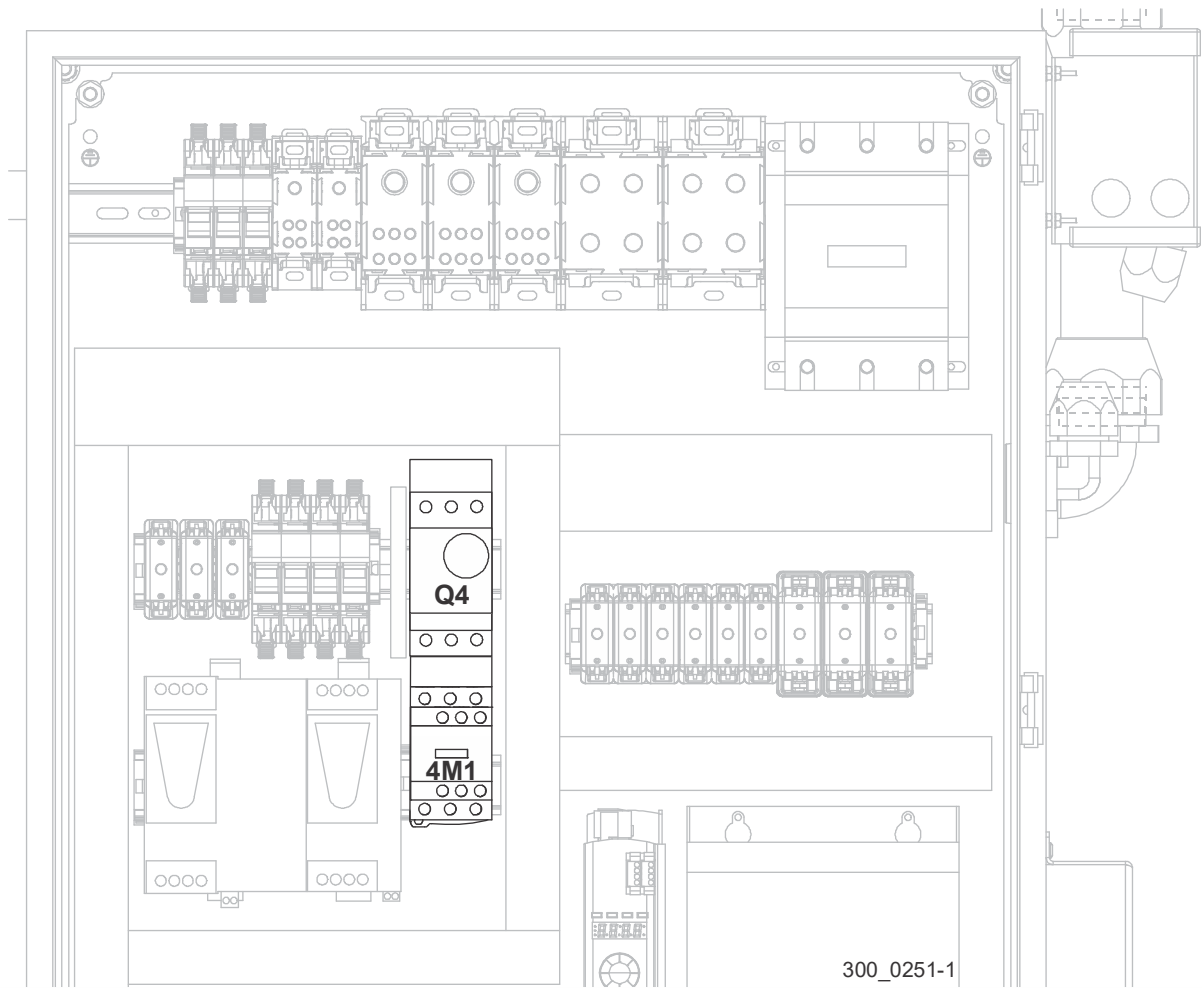

7 Electrical Information

Control Layout (LT300 Rev. A1.00 - B2.02 Only)

7.6 Control Layout (LT300 Rev. A1.00 - B2.02 Only)

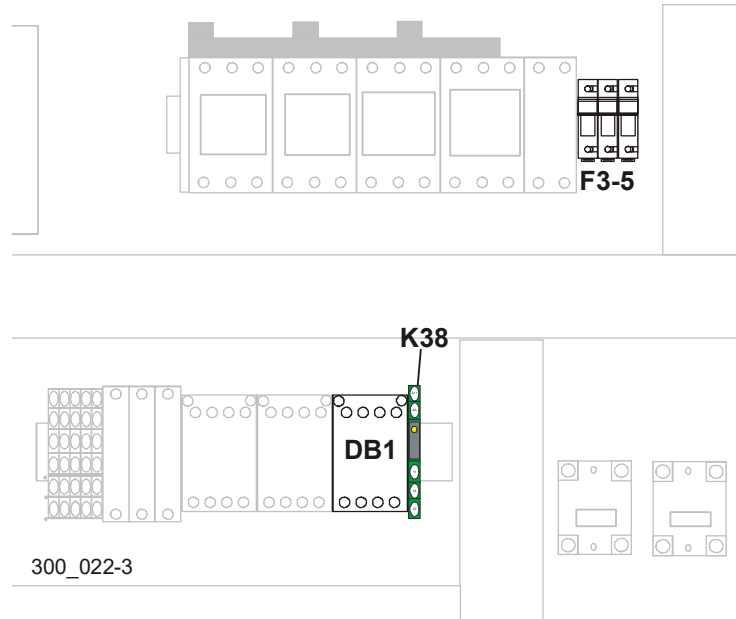

7.7 Component List (LT300/WM3000/WM3500 Rev. B3.00+ Only)		
Item	Wood-Mizer Part No.	Description
K13	024890	Contactora, 3 Pole 9A 24VDC Coil
FU12-FU14	052793	Fuse, 3A 600V Class CC Delay
FS1	052789	Switch, Single Lever Foot
L21	025244	Valve, MAC 400 Series Solenoid
M5	050292	Motor, 3/4HP 230/460 3P 1725RPM

7.8 Component List (WM4000 Rev. A1.00+ Only)		
Item	Wood-Mizer Part No.	Description
4M1	024890	Contactora, 3 Pole 9A 24VDC Coil
FS1	052789	Switch, Single Lever Foot
L21	025244	Valve, MAC 400 Series Solenoid
M5	050292	Motor, 3/4HP 230/460 3P 1725RPM
Q4	068097	Motor Protector, 1.0-1.6 Manual

7.9 Component List (LT300 Rev. A1.00 - B2.02 Only)		
Item	Wood-Mizer Part No.	Description
DB1	024890	Contactora, 3 Pole 9A 24VDC Coil
F3-F5	052793	Fuse, 3A 600V CCMR Class CC
FS1	052789	Switch, Single Lever Foot
K38	024925	Relay, Solid State 24V 2A DIN
L21	025244	Valve, MAC 400 Series Solenoid
M5	050292	Motor, 3/4HP 230/460 3P 1725RPM

INDEX

A

alignment 3-1

E

electrical components 7-6

electrical information
layout 7-3, 7-4, 7-5
schematic 7-1, 7-2

I

installation
air 2-6
debarker 2-5
electrical 2-8, 2-14, 2-20, 2-23
LT300 Modification 2-1

M

maintenance
blade 5-2
pivot lubrication 5-1

O

operation 4-1

R

replacement parts
air box 6-9
cutting head 6-6
debarker 6-3
debarker (complete) 6-1
pivot arm 6-8
swing arm 6-4

S

safety 1-1