

Debarker Option

Safety, Operation, Maintenance & Parts Manual

038771

rev. A.01



Safety is our #1 concern! Read and understand all safety information and instructions before operating, setting up or maintaining this machine.

Form #1264

Table of Contents		Section-Page
SECTION 1	SAFETY	1-1
SECTION 2	INSTALLATION	2-1
2.1	LT300 Modification	2-1
2.2	Debarker Installation	2-5
2.3	Air Installation	2-6
2.4	Electrical Installation	2-8
SECTION 3	ALIGNMENT	3-1
SECTION 4	OPERATION	4-1
SECTION 5	MAINTENANCE	5-1
SECTION 6	REPLACEMENT PARTS	6-1
6.1	Debarker (Complete)	6-1
	<i>LT300 Rev. B3.00+</i>	
6.2	Debarker (Complete)	6-2
	<i>LT300 Rev. A1.00 - B2.02</i>	
6.3	Debarker	6-3
6.4	Swing Arm Assembly	6-4
6.5	Cutting Head Assembly	6-6
6.6	Pivot Arm Assembly	6-8
6.7	Air Box Assembly	6-9
SECTION 7	ELECTRICAL INFORMATION	7-1
7.1	Schematic	7-1
7.2	Control Layout	7-2
7.3	Component List	7-3
	INDEX	I

SECTION 1 SAFETY



DANGER! Make sure all electrical installation, service and/or maintenance work is performed by a qualified electrician and is in accordance with applicable electrical codes.

DANGER! Hazardous voltage inside the electric control box and at the motor can cause shock, burns, or death. Disconnect and lock out power supply before servicing! Keep all electrical component covers closed and securely fastened during mill operation.

DANGER! Make sure all guards and covers are in place and secured before operating the debarker option. Failure to do so may result in serious injury.

DANGER! Keep all persons out of the path of moving equipment when operating the debarker. Failure to do so will result in serious injury.



WARNING! Before replacing the debarker blade, move the sawmill blade guide arm in front of the sawmill blade to cover the blade teeth. Failure to do so may result in serious injury or death.

SECTION 2 INSTALLATION

Move the saw head to a location and height where the head air box and area between the blade wheels is easily accessible.

Turn the sawmill off and lock out electrical power.



DANGER! Hazardous voltage inside the electric control box and at the motor can cause shock, burns, or death. Disconnect and lock out power supply before servicing!

Release the blade tension and remove the sawmill blade, if necessary. Turn the main air valve off.

2.1 LT300 Modification

Older LT300 sawmills must be modified to accommodate the debarker option. If your LT300 is Rev. B1.01 or newer, skip to [Section 2.2](#).

NOTE: LT300's prior to Rev. A3.00 with the original Yaskawa AC drives must be upfitted with the Altivar drive kit 052403 before the debarker retrofit is installed. Follow the instructions supplied with the drive kit before proceeding with this retrofit.

See Figure 2-1. Use the provided template to mark the area in saw head throat. Use a die grinder and/or metal saw to remove the section.

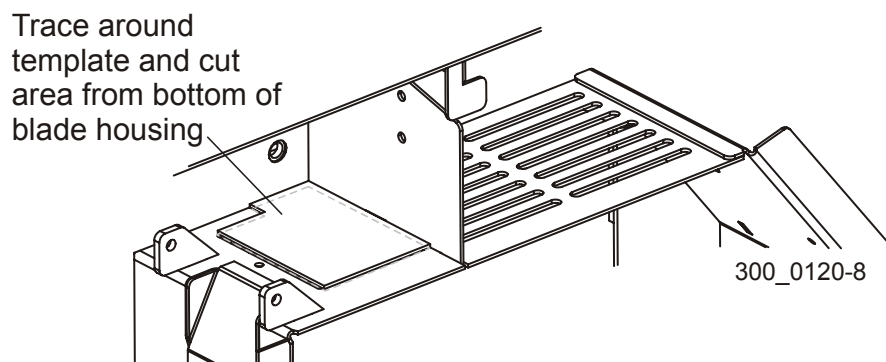

FIG. 2-1

See Figure 2-2. Place the second template against the blade housing angle and mark the two hole locations. Drill two 5/16" diameter holes through the housing.

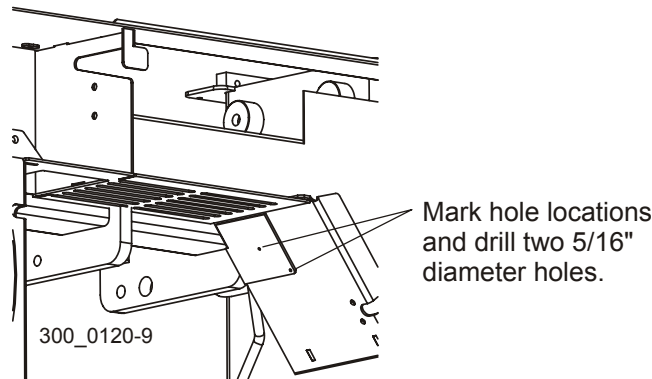

FIG. 2-2

See Figure 2-3. Install the drilling fixture to the saw head. Place the fixture so the horizontal positioning bolts are against the board return braces and the vertical positioning bolt is against the bottom of the saw head tube. Tighten the two clamping bolts to secure the fixture to the saw head.

Install the 3/16" guide bushing to one of the fixture holes and drill a 3/16" hole through both walls of the saw head tube. Move the bushing to the other hole and repeat. Install the 5/8" guide bushing to the bottom hole and drill through both walls. Install the 17/32" guide bushing to the top hole and drill through both walls. Remove the fixture.

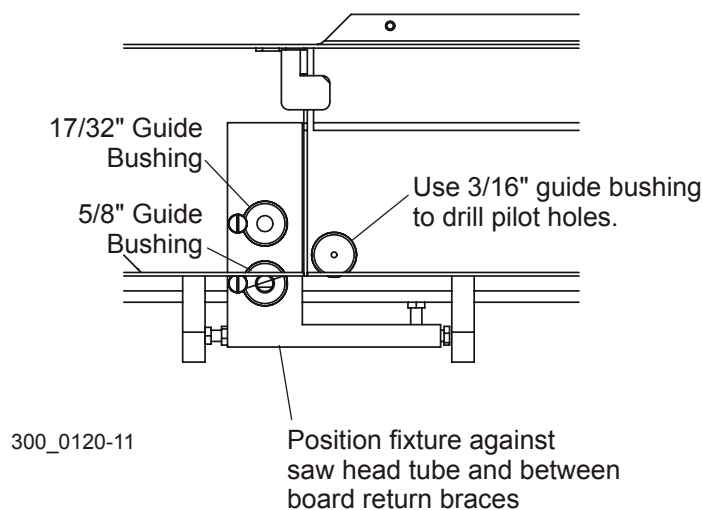

FIG. 2-3

2

Installation

LT300 Modification

See Figure 2-4. Install the third template around the existing screws at the top of the side of the head air box. Mark the two hole locations and drill two 5/16" holes through the box wall. Check as the drill bit enters the box that it does not contact any existing components or air lines.

Mark two locations on the side of the head air box and drill two 1/2" diameter holes, again being careful not to contact any existing components or air lines inside the box.

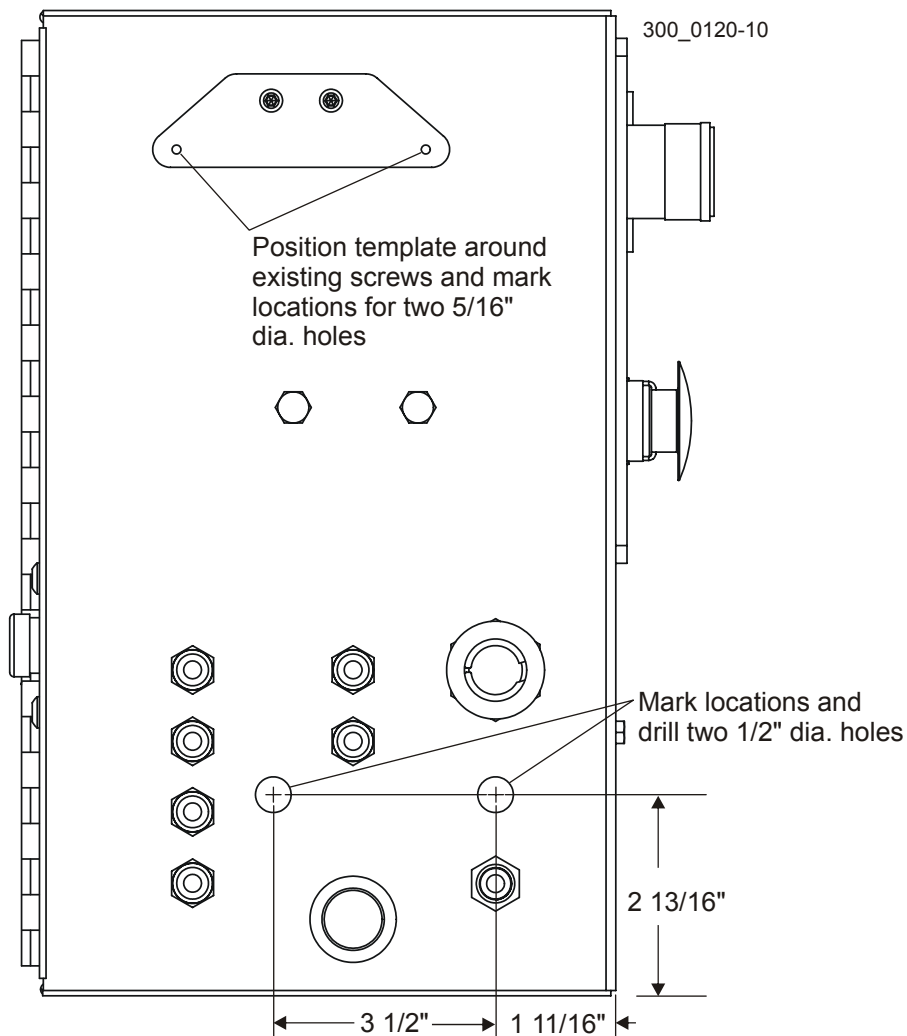

FIG. 2-4

See **Figure 2-5**. In the control cabinet, drill two 7/8" holes in the back of the cabinet as indicated.

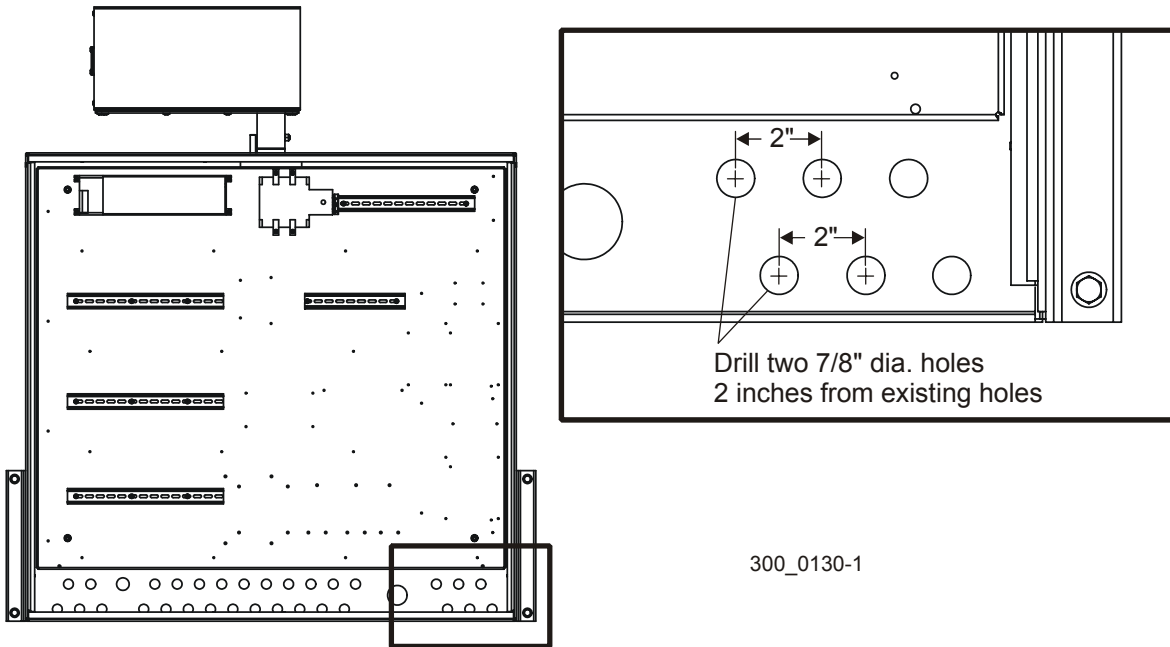

FIG. 2-5

Reprogram the display and CPU.

2.2 Debarker Installation

NOTE: LT300 sawmills prior to Rev. B1.01 must be modified before the debarker option can be installed ([See Section 2.1](#)).

Remove the debarker mounting bolts and lock washers from the mounting block assembly. Remove the cylinder arm mounting bolts, flat washers and lock nuts from the cylinder arm mounting plate.

Position the debarker against the saw head tube, aligning the mounting holes to the holes in the saw head tube and the holes in the cylinder arm plate with the holes in the blade housing angle.

Secure the debarker to the saw head with the mounting bolts and lock washers. Secure the cylinder arm to the blade housing with the mounting bolts, flat washers and lock nuts.

See Figure 2-6.

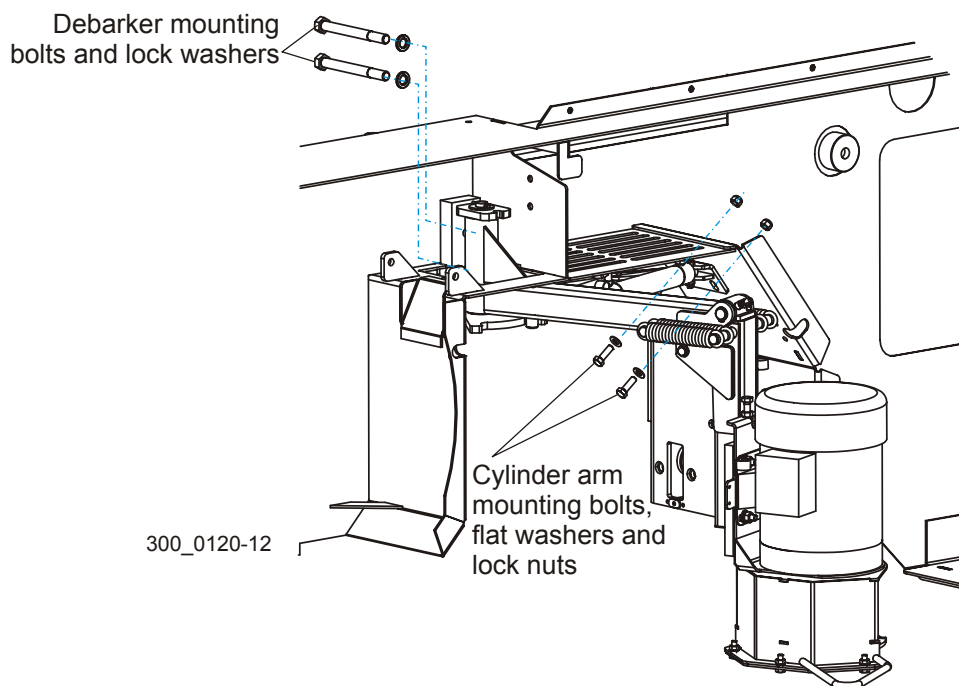

FIG. 2-6

2.3 Air Installation

See **Figure 2-7**. Using the provided 1/4" air tubing, connect the regulator to the gauge and the solenoid as shown below.

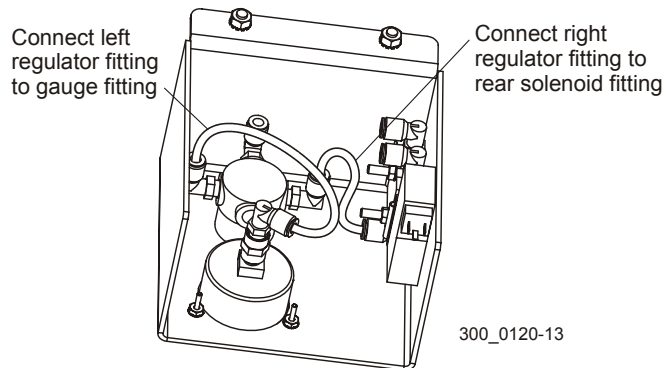

FIG. 2-7

See **Figure 2-8**. Mount the air control box to the LT300 head air box using the two mounting bolts and self-locking nuts supplied.

Install the provided 1/4" tube bulkhead fitting to the left-bottom hole in the air box.

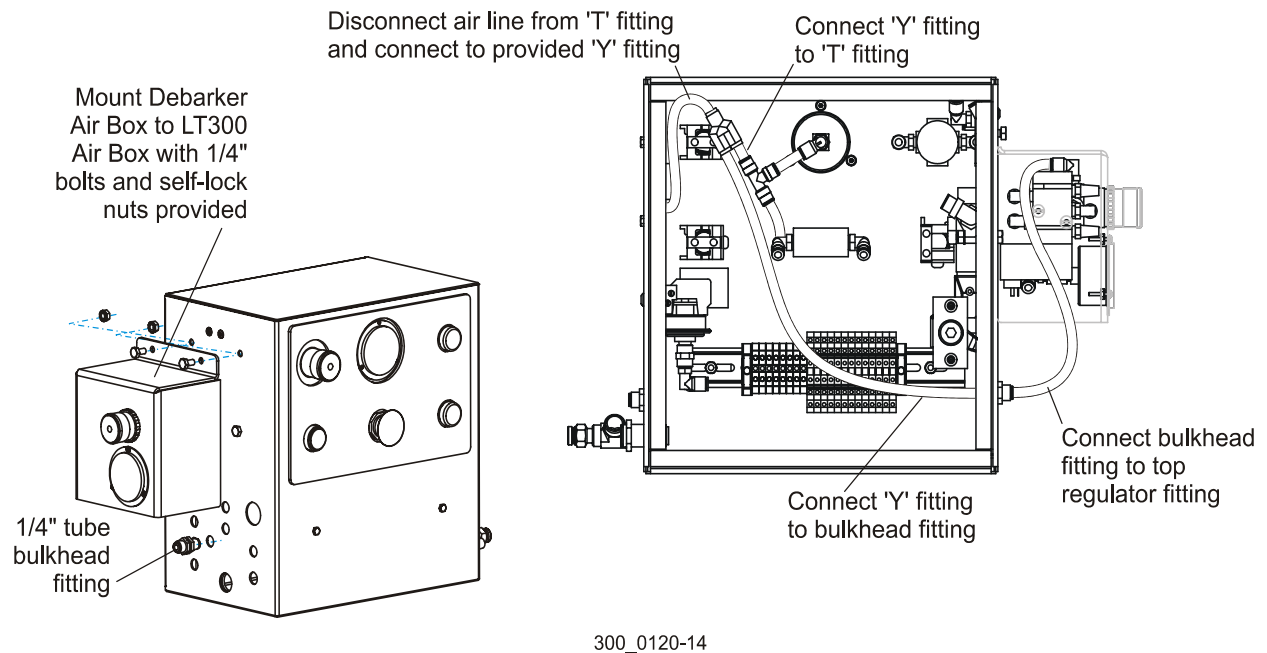

FIG. 2-8

2

Installation *Air Installation*

See **Figure 2-9**. Connect an air line to each of the air valve fittings. Route the lines through the saw head channel, through the clamp on the debarker and connect them to the debarker air cylinder fittings.

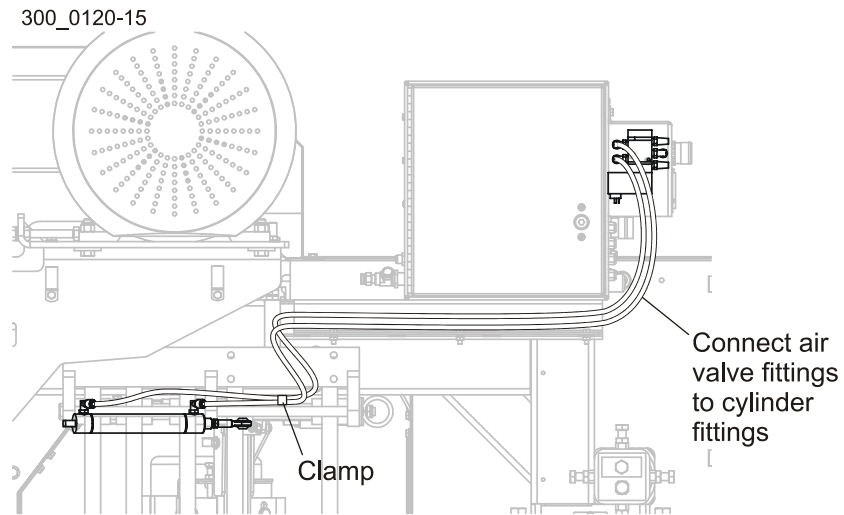

FIG. 2-9

Turn on the main air valve and adjust the debarker air regulator until the gauge indicates 40-80 psi.

2.4 Electrical Installation

See Figure 2-10. Install the provided fuses (F3, F4 & F5), contactor (DB1) and relay (K38) in the electrical control cabinet. Remove the rail clamps around the existing components as necessary and slide the components to make room for the new components. Replace the rail clamps.

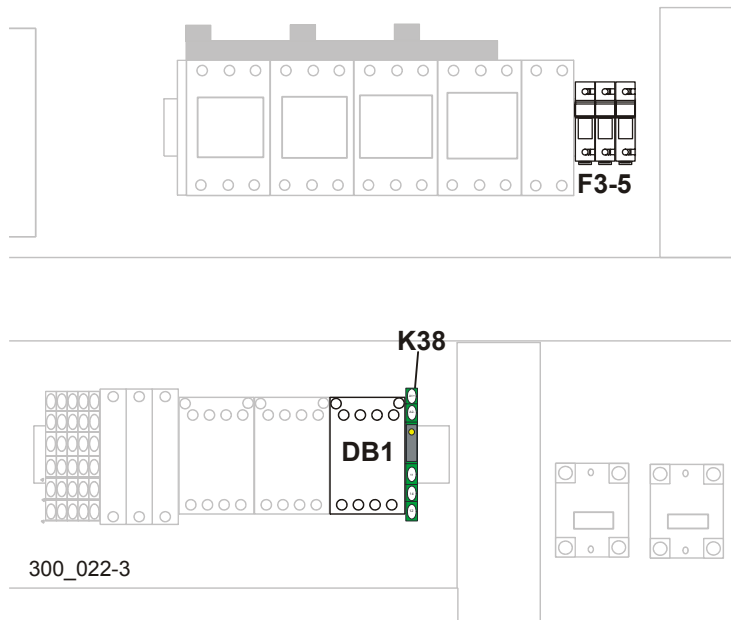

FIG. 2-10

2

Installation

Electrical Installation

See **Figure 2-11**. Use the jumper wires (300, 301 & 302) to connect the fuses. Connect wire #300 to breaker Q7, terminal #1 and to fuse F3. Connect wire #301 to breaker Q7, terminal #3 and to fuse F4. Connect wire #302 to terminal lug W1, terminal #X3 and to fuse F5. Use jumper wires (375, 376 & 377) to connect the fuses to terminals L1, L2 & L3 of contactor DB1.

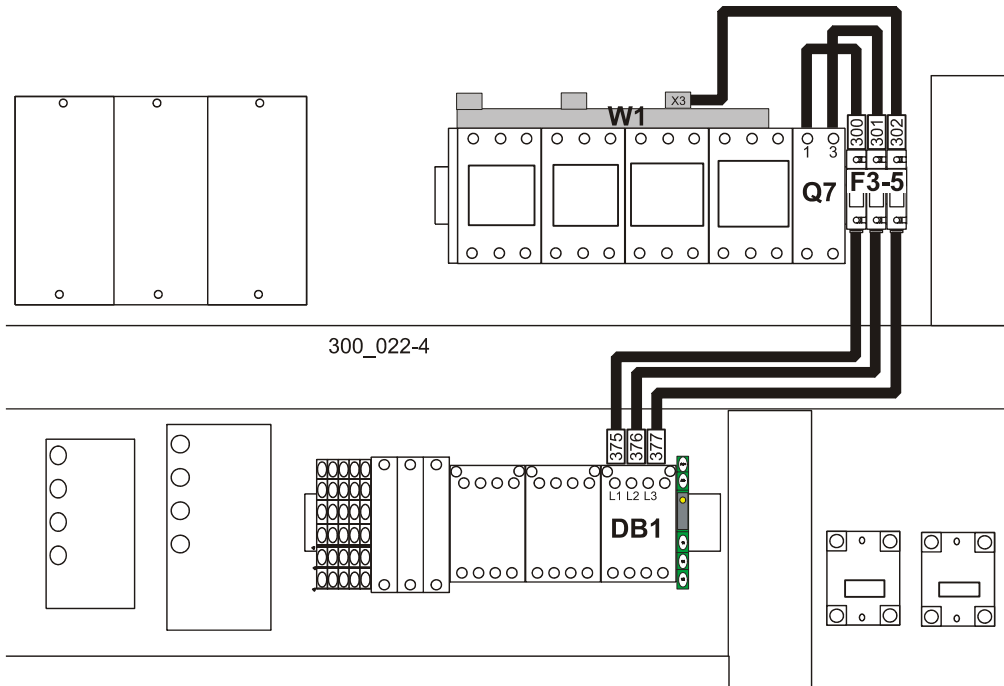

FIG. 2-11

See **Figure 2-12**. Place the foot switch on the floor of the operator station and route the cable to the electrical cabinet. Insert the cable through one of the holes in the bottom of the cabinet and secure with the cable connector provided. Connect the green ground wire to the grounding bar in the bottom of the cabinet. Remove wireway covers as necessary and route black wire #378 to PLC module X5 and connect to terminal A5. Route white wire #56 to contactor K1 and connect to terminal 44.

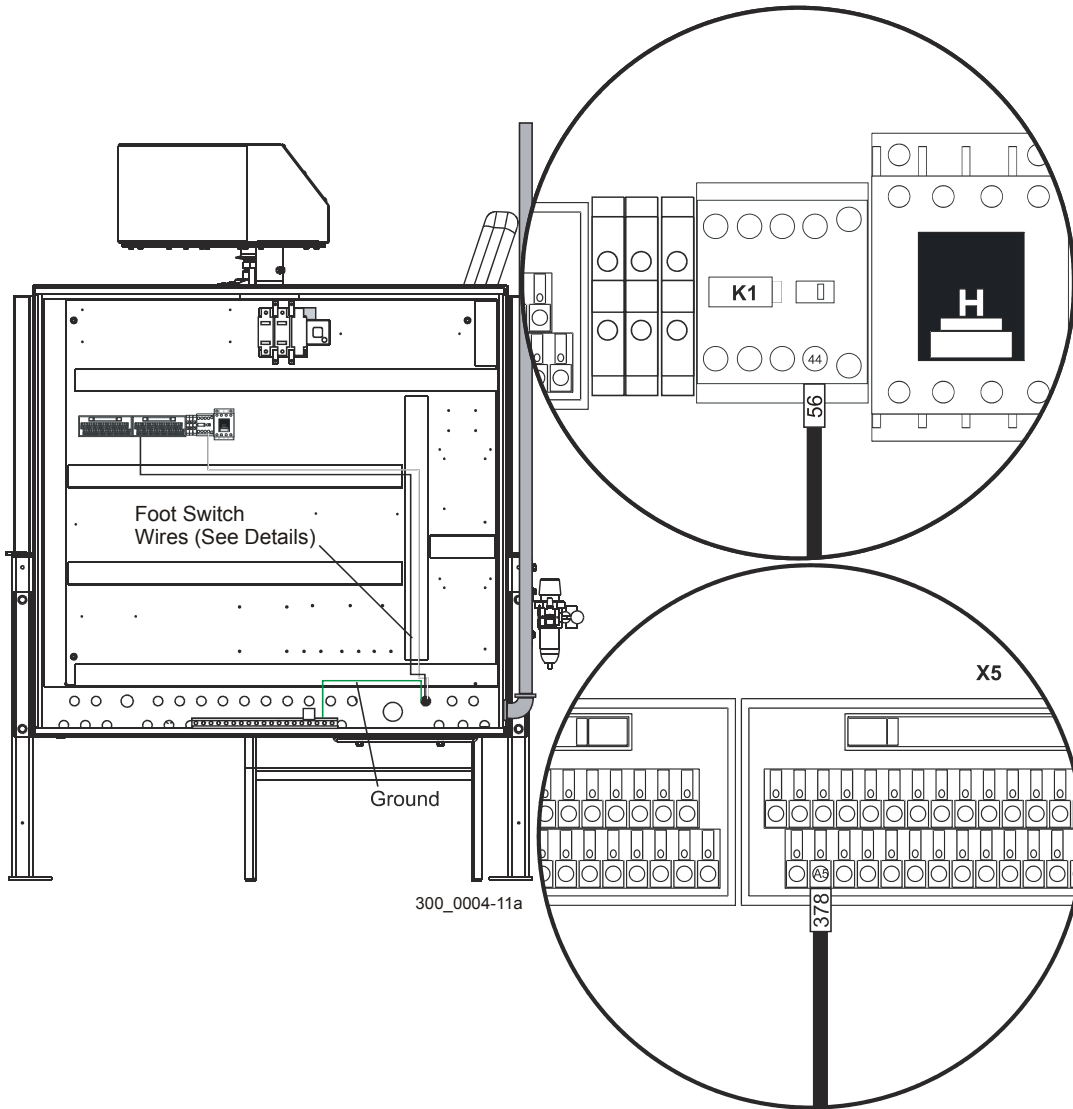

FIG. 2-12

2

Installation

Electrical Installation

See Figure 2-13. Install the debarker motor harness to the remaining hole at the bottom of the electrical cabinet and secure with the connector provided. Connect the green ground wire to the grounding bar at the bottom of the cabinet. Route wires #21, 22 & 23 to contactor DB1. Connect wire #21 to DB1 terminal T1, wire #22 to DB1 terminal T2 and wire #23 to DB1 terminal T3.

Route wire #56 to the terminal strip X19 A1. Route wire #379 to PLC module X5 and connect to terminal A6.

Remove existing connection between terminal strip X19 A1 and PLC module X5, terminal A6.

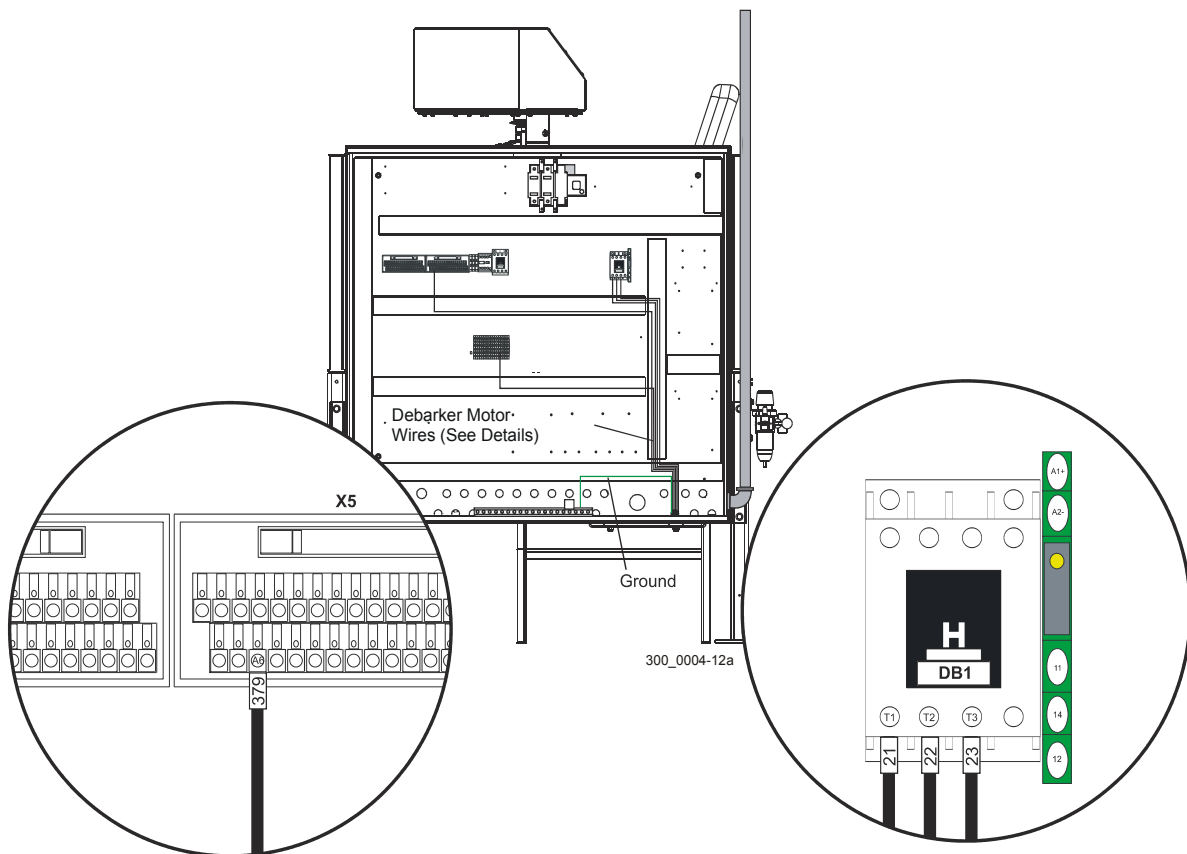

FIG. 2-13

Route the motor harness from the electrical cabinet, underneath the operator station, through the LT300 wireway and cable carrier. Continue routing the harness up the mast through the zippered cable sleeve and underneath the saw motor to the debarker motor. Open the debarker motor terminal housing and use wire nuts to connect wire #21 to debarker wire T1, wire #22 to terminal wire T2, wire #23 to wire T3, wire #56 to wire J2

and wire #379 to wire J1. Connect motor wire T4 to T7, T5 to T8 and T6 to T9. Connect the green ground wire to the motor ground terminal and replace the terminal housing cover.

2

Installation

Electrical Installation

See **Figure 2-14**. Install the blue debarker control wires as shown.

Wire #248: PLC module X15, terminal B6 to relay K38, terminal A1.

Wire #278: Contactor DB1, terminal A1 to relay K38, terminal 14.

Wire #68: to relay K38 terminal 11, provided fuse Q9 terminal 2.

Wire #55: Contactor DB1, terminal 13, contactor K4, terminal A1.

Wire #53: Contactor DB1, terminal A2 , relay K38, terminal A2, contactor K4, terminal A2.

Wire #4 from the head/air box labeled "spare" in the electrical box mark as #381. Connect to contactor DB1, terminal 14.

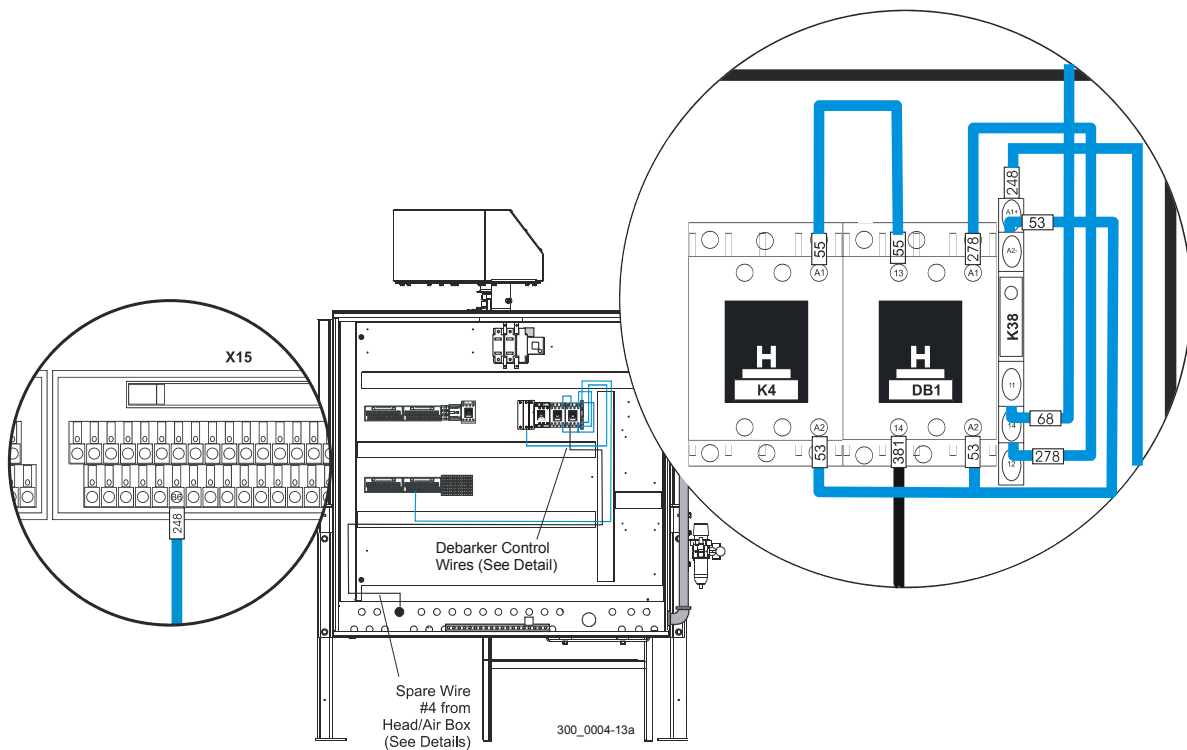

FIG. 2-14

See Figure 2-15. Connect the supplied DIN cable to the air solenoid valve in the debarker air control box. Route the cable through the side of the LT300 air box and secure with the cable connector. In the LT300 air box, connect wire #381 to terminal block X50, terminal A1. Connect wire #53 to terminal block X61, terminal C2.

Locate wire #4 labeled “spare” in the LT300 air box. Connect wire #4 to terminal block X50, terminal A2.

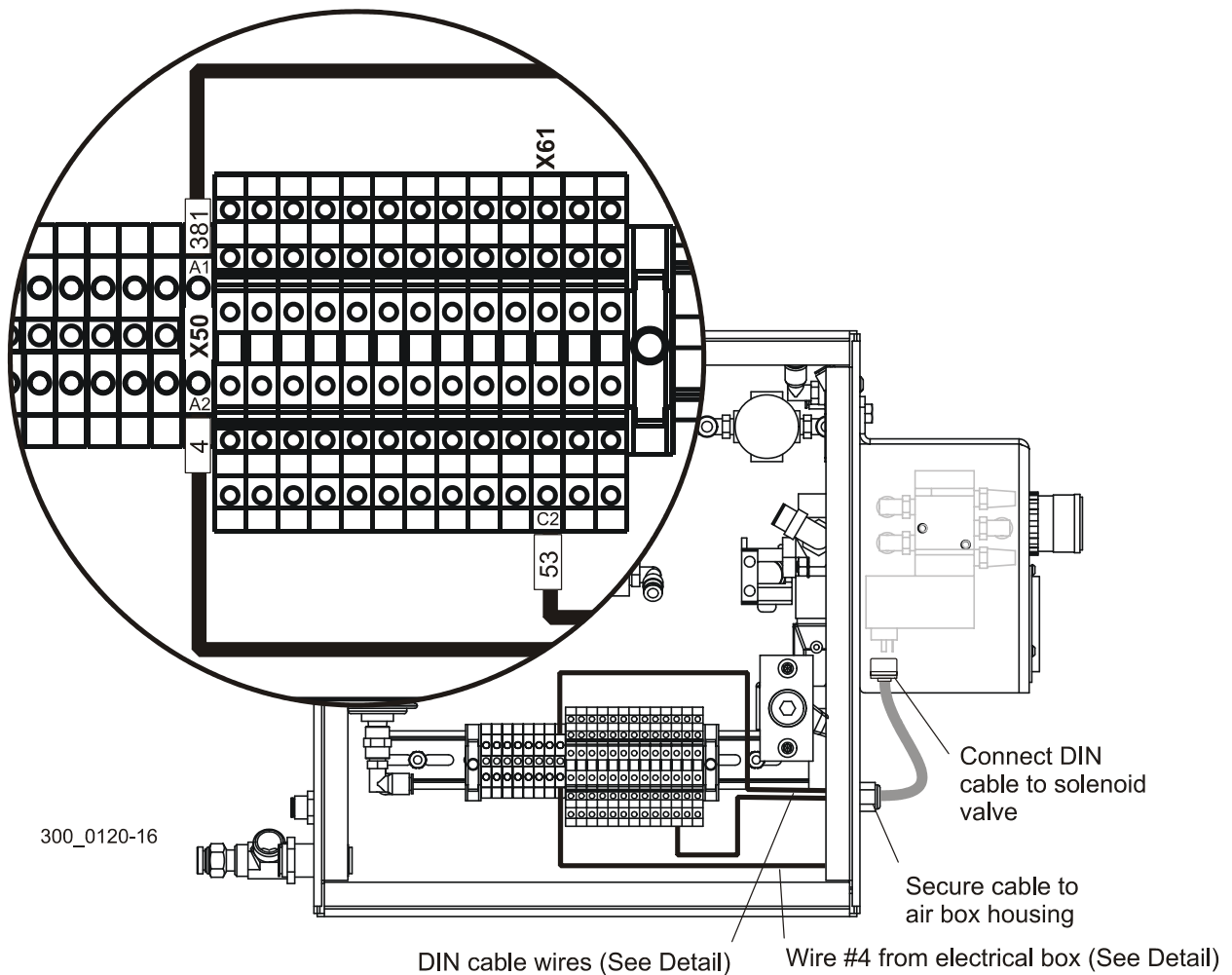

FIG. 2-15

This completes the debarker installation. If, during operation, the debarker moves opposite of proper operation, exchange the position of the air hoses connecting the debarker air cylinder to the valve.

SECTION 3 ALIGNMENT



DANGER! Before performing any service to this equipment, turn the key to the OFF (0) position and remove the key. Failure to do so will result in serious injury or death.

The debarker blade should be aligned to the sawmill blade to insure proper operation. The debarker blade should be parallel with and aligned vertically with the sawmill blade.

1. Use the debarker foot switch to move the debarker all the way in. Turn off and lockout power to the sawmill. This will prevent the debarker from being turned on while performing alignment procedures.
2. Check the squareness of the debarker with the sawmill blade. Adjust the debarker mounts if necessary until the debarker is square with the sawmill blade.

Loosen the bottom debarker mounting bolt and loosen the jam nuts on the adjustment bolts. Turn the adjustment bolts as necessary until the debarker is square with the sawmill blade. Retighten the jam nuts and bottom debarker mounting bolt.

See Figure 3-1.

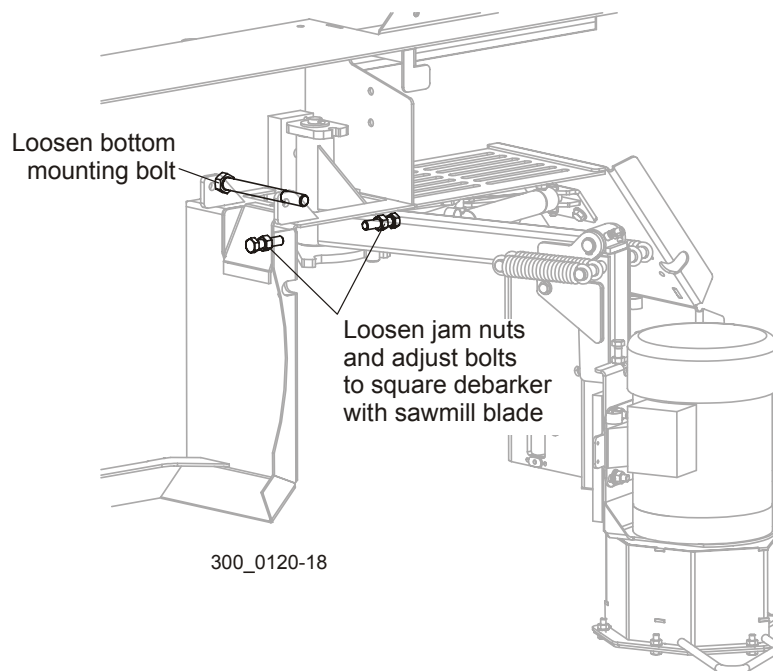

FIG. 3-1

- Clip the blade guide alignment tool to the sawmill blade. Make sure the tool lies flat on the blade and does not contact a tooth that could cause it to angle.

See Figure 3-2.

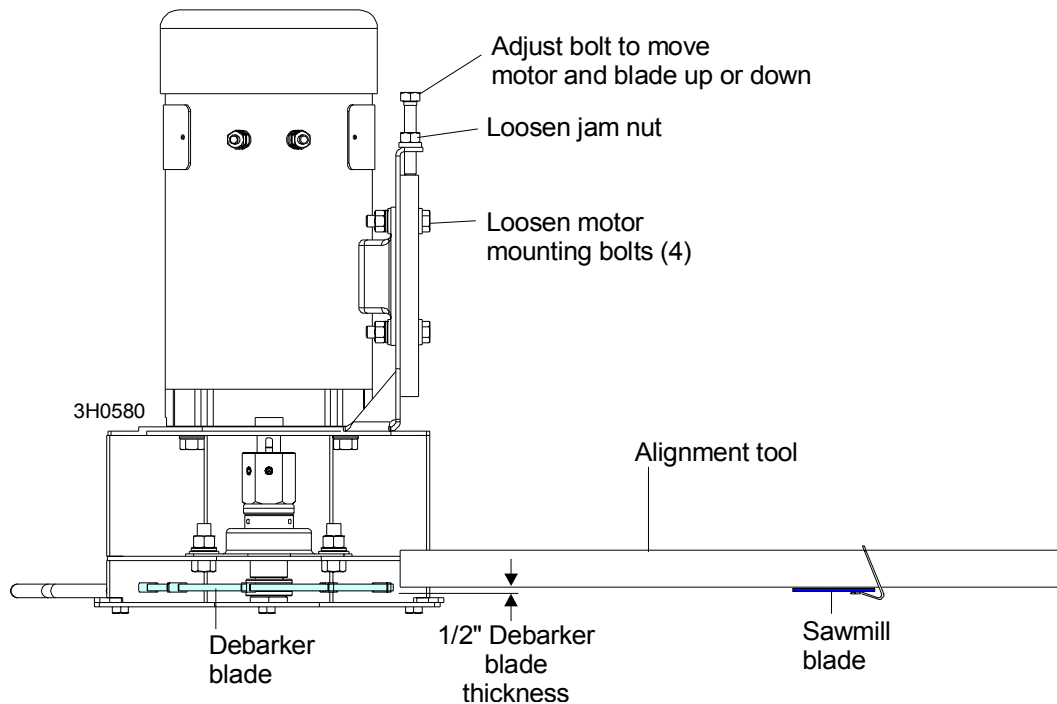

FIG. 3-2

- Check the height of the debarker blade against the alignment tool. The bottom edge of the tool should align with the center of the debarker blade.
- To adjust the blade up or down, loosen the four blade motor mount bolts. Loosen the jam nuts on the adjustment bolts. Turn the adjustment bolts clockwise to push the motor and blade down. Turn the adjustment bolts counterclockwise and slide the motor up to raise the motor and blade. Retighten the adjustment bolt jam nuts and four motor mount bolts.
- Insert the key and use the debarker in/out switch to move the debarker all the way out. Turn the key to OFF (0) and remove the key.
- Move the blade guide alignment tool on the sawmill blade and check the position of the debarker blade against the tool. If the debarker blade is not centered with the tool, readjust the debarker mounting bolts to adjust the debarker assembly parallel to the blade.

3

Alignment

8. If the debarker blade tends to climb during use, this indicates the blade is tilted up. Remove the shim located at the pivot arm stop to tilt the debarker blade down. Remove the two stop block mounting screws, remove the shim and replace the stop block and mounting screws.

See Figure 3-3.

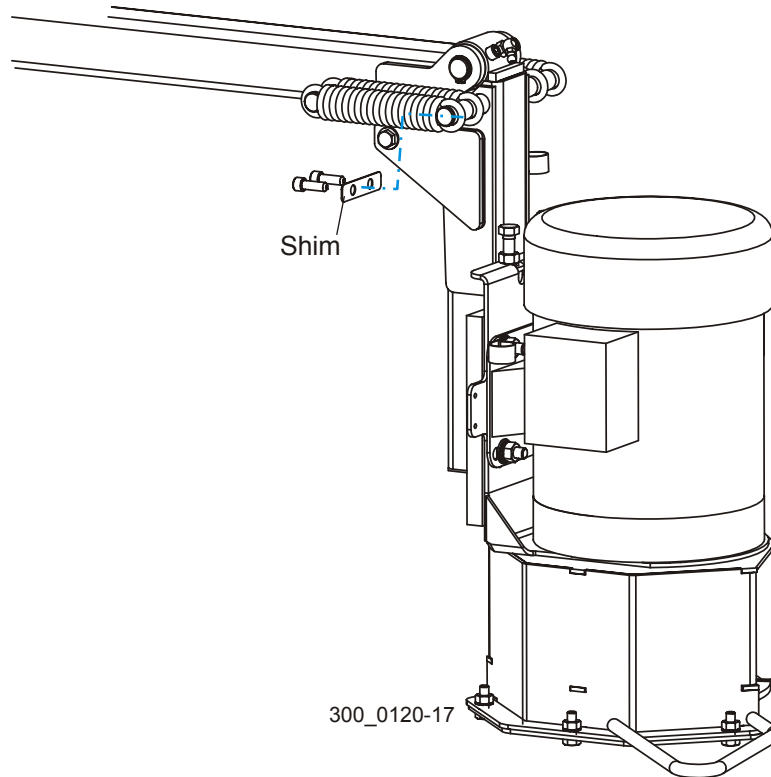

FIG. 3-3

SECTION 4 OPERATION

Use the foot switch to operate the debarker option. Push and hold the switch to activate the air cylinder to pivot the debarker blade against the log.

NOTE: The sawmill motor must be on and the feed activated in the forward direction for the debarker option to be operational.

At the end of the cut, release the foot switch to pivot the debarker away from log.

SECTION 5 MAINTENANCE

Lubricate the pivot joint with a NLGI #2 grade lithium grease every 40 hours of operation.

See Figure 5-1.

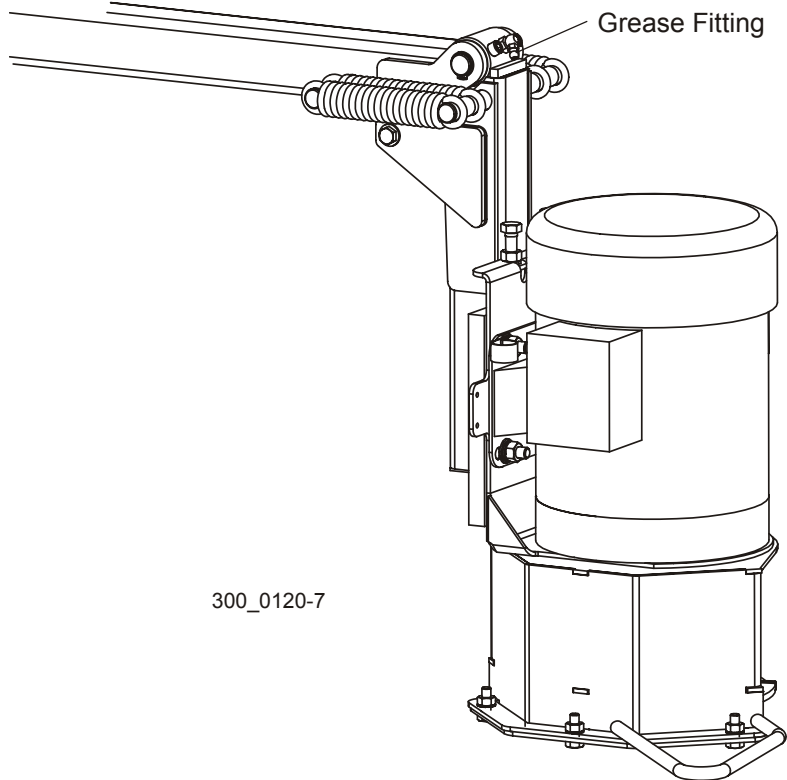

FIG. 5-1

Periodically check the debarker blade. Align or replace as needed.



WARNING! Before replacing the debarker blade, move the sawmill blade guide arm in front of the sawmill blade to cover the blade teeth. Failure to do so may result in serious injury or death.

To replace the debarker blade, remove the lower blade guard plate. Place one wrench on the blade arbor, above the blade bearing. Place the other wrench on the lower bolt and rotate clockwise (bolt has left-hand threads). Remove the bolt and washer. Remove the blade and spacer.

Reinstall the spacer with the new blade. Reinstall the bolt and washer and turn counter-clockwise to tighten to 35 foot-pounds (± 5). Reinstall the blade guard plate.



CAUTION! Tighten the blade bolt manually. Using power-assisted tools may result in over-torquing and damage to the bolt.

6 Replacement Parts

Debarker (Complete)

SECTION 6 REPLACEMENT PARTS

6.1 Debarker (Complete)

LT300 Rev. B3.00+

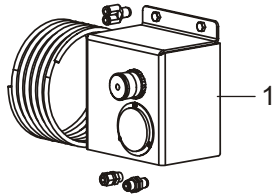

300_0120-20

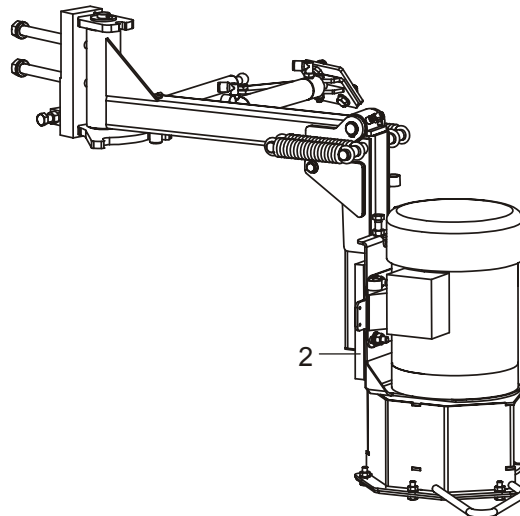

REF	DESCRIPTION (◆ Indicates Parts Available In Assemblies Only)	PART #	QTY.	
	DEBARKER KIT, LT300 FIELD INSTALLED (LT300 w/o Pantograph Cable Boom)	003984	1	
	DEBARKER KIT, LT300 FIELD INSTALLED (LT300 w/Pantograph Cable Boom)	006804	1	
1	Air Box Parts (See Section 6.7)			
2	Debarker Parts (See Section 6.3)			
	Electrical Components (See Section 7.5)			
	Harness Assembly, Debarker Motor (LT300 w/o Pantograph Cable Boom)	052786	1	
	Harness Assembly, Debarker Motor (LT300BX6 w/o Pantograph Cable Boom)	052786-BX	1	
	Harness Assembly, Debarker Motor (LT300 w/Pantograph Cable Boom)	052786-P	1	
	CABLE ASSEMBLY, DEBARKER AIR SOLENOID	052785	1	

6.2 Debarker (Complete)

LT300

Rev. A1.00 - B2.02

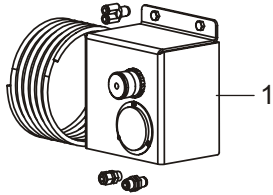

300_0120-1

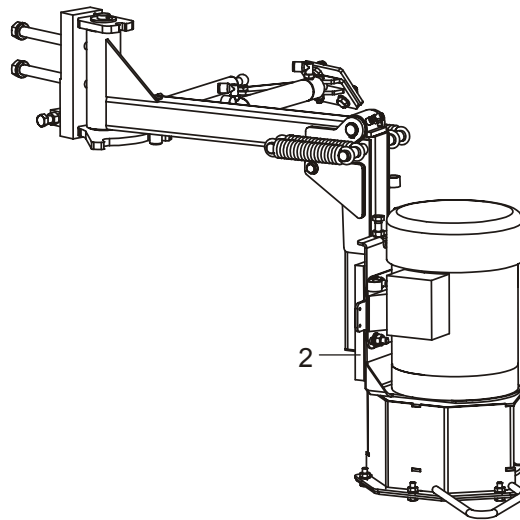

REF	DESCRIPTION (◆ Indicates Parts Available In Assemblies Only)	PART #	QTY.	
	DEBARKER KIT, LT300 FIELD INSTALLED (LT300 w/o Pantograph Cable Boom)	038771	1	
	DEBARKER KIT, LT300 FIELD INSTALLED (LT300 w/Pantograph Cable Boom)	006805	1	
1	Air Box Parts (See Section 6.7)			
2	Debarker Parts (See Section 6.3)			
	Electrical Components (See Section 7.3)			
	Harness Assembly, Debarker Motor (LT300 w/o Pantograph Cable Boom)	052786	1	
	Harness Assembly, Debarker Motor (LT300 w/Pantograph Cable Boom)	052786-P	1	
	Cable Assembly, Debarker Air Solenoid	052785	1	

6 Replacement Parts

Debarker

6.3 Debarker

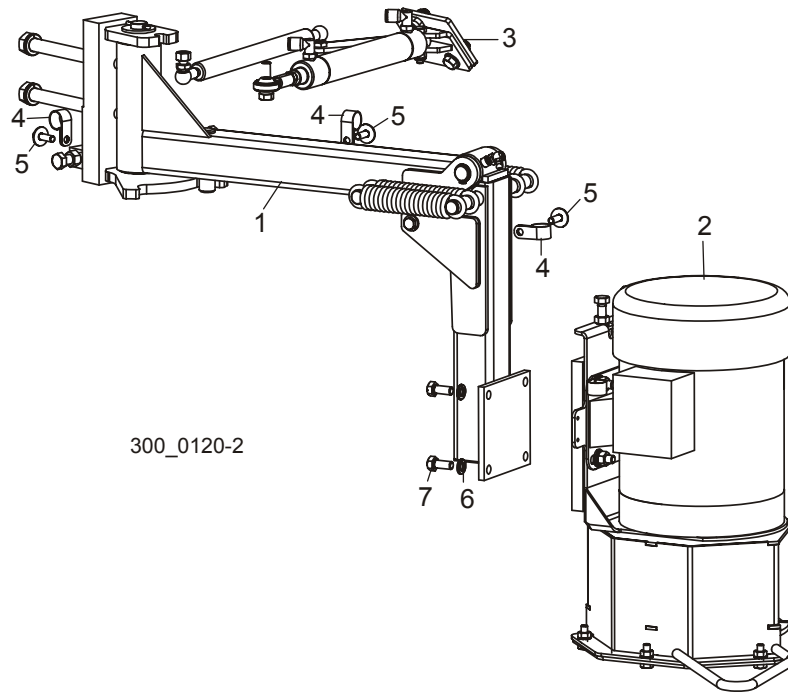

REF	DESCRIPTION (◆ Indicates Parts Available In Assemblies Only)	PART #	QTY.
	DEBARKER ASSEMBLY, LT300	037610	1
1	Swing Arm Parts (See Section 6.4)		
2	Cutting Head Parts (See Section 6.5)		
3	Pivot Arm Parts (See Section 6.6)		
4	Clamp, 5/8" EMT Coated	010748	3
5	Bolt, 1/4-20 x 3/4" Hex Head w/Conical Washer	F05005-134	3
6	Washer, 5/16" Split Lock	F05011-13	4
7	Bolt, 5/16-18 x 3/4" Hex Head	F05006-5	4

6.4 Swing Arm Assembly

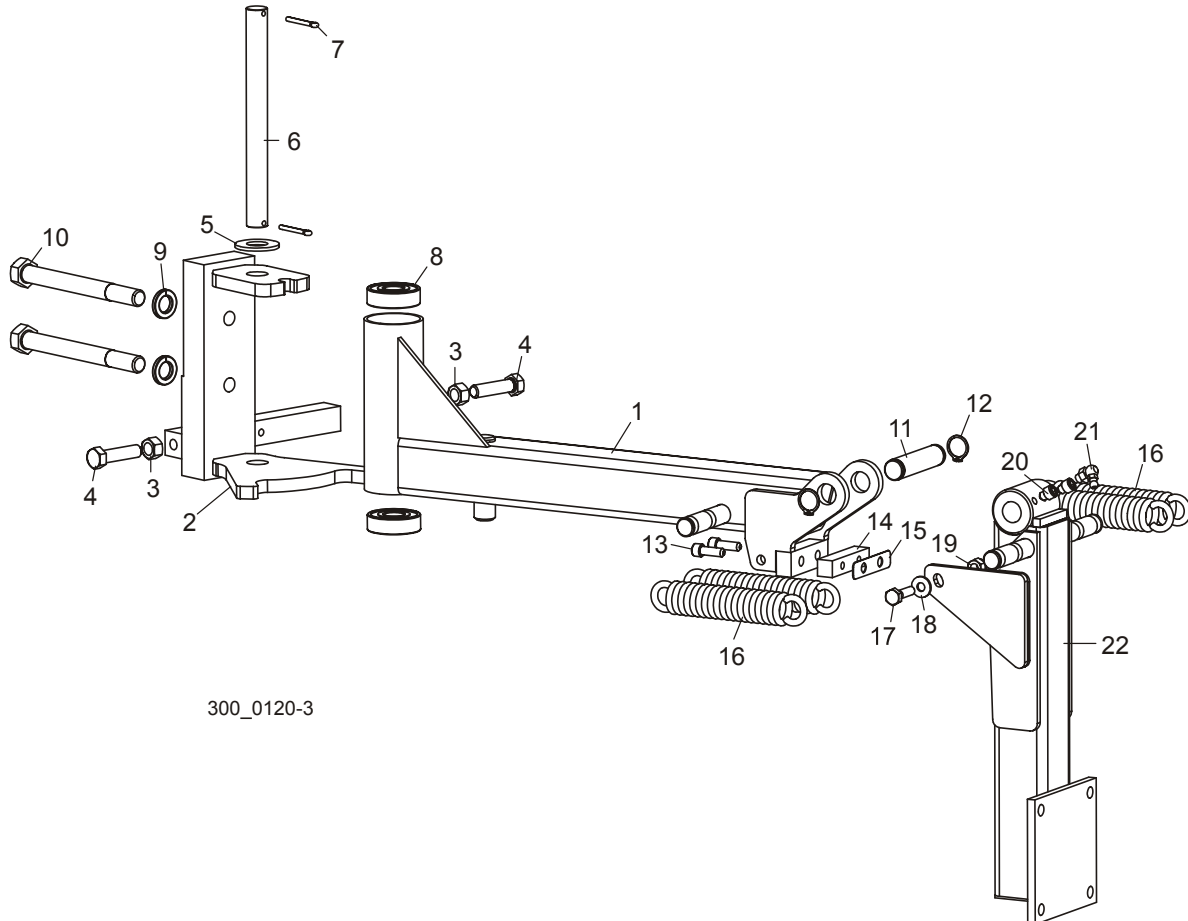

300_0120-3

REF	DESCRIPTION (◆ Indicates Parts Available In Assemblies Only)	PART #	QTY.
	ARM ASSEMBLY, LT300 DEBARKER SWING	037612	1
	Arm Assembly, LT300 Debarker Upper	037615	1
1	Arm Weldment, LT300 Debarker Upper	037616	1
2	Mount Weldment, LT300 Debarker Arm	037617	1
3	Nut, 3/8-16 Hex	F05010-1	2
4	Bolt, 3/8-16 x 1 1/2" Hex Head Full Thread	F05007-17	2
5	Washer, 5/8" SAE Flat	F05011-5	1
6	Pin, 5/8" Dia. x 6 9/16" Long Pivot	046034	1
7	Pin, 1/8" x 1" Cotter	F05012-1	2
8	Bearing 5/8" ID x 1.7548" OD x .4724" Thick	P06030-1	2
9	Washer, 1/2" Split Lock	F05011-9	2
10	Bolt, 1/2-13 x 5" Hex Head Grade 5	F05008-66	2
11	Pin, Pivot	023646	1
12	Ring, 5/8" Outside Retaining	F04254-2	2
13	Screw, 1/4-20 x 3/4" Socket Head	F05005-26	2

6**Replacement Parts***Swing Arm Assembly*

14	Bar, Pivot Stop	046044	1	
15	Shim, Pivot Stop	046045	1	
16	Spring, Debarker Arm	021185	4	
17	Bolt, 1/4-20 x 1" Hex Head	F05005-38	1	
18	Washer, 1/4" SAE Flat	F05011-11	1	
19	Nut, 1/4-20 Hex Nylon Lock	F05010-69	1	
20	Screw, 1/4-28 x 1 1/4" Socket Head	F05005-106	2	
21	Fitting, 1/4-28 90° Grease	P04108	1	
22	Arm Weldment, Debarker Lower Swing	037613	1	

6.5 Cutting Head Assembly

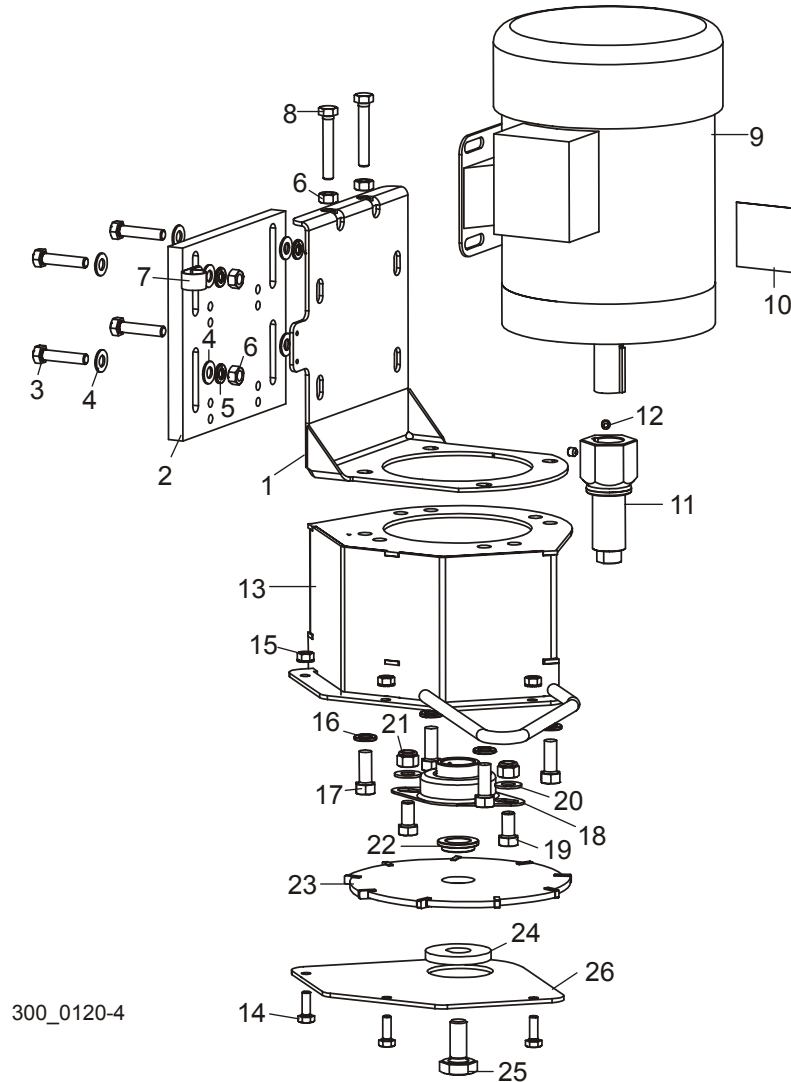

REF	DESCRIPTION (◆ Indicates Parts Available In Assemblies Only)	PART #	QTY.
	HEAD ASSEMBLY, LT300 DEBARKER CUTTING	037611	1
1	Bracket Weldment, Debarker Tensioner	023622	1
2	Plate, Aluminum Motor Mount	023620	1
3	Bolt, 5/16-18 x 1 1/2" Hex Head Full Thread	F05006-2	4
4	Washer, 5/16" SAE Flat	F05011-17	8
5	Washer, 5/16" Split Lock	F05011-13	4
6	Nut, 5/16-18 Hex	F05010-17	6
7	Clamp, 5/8" EMT Coated	010748	1
8	Bolt, 5/16-18 x 2" Hex Head Full Thread	F05006-13	2
9	Motor, 3/4 HP 230/460V 3P 1725 RPM	050292	1

6**Replacement Parts***Cutting Head Assembly*

10	Mandrel, 7/8" Machined Debarker Blade	016122	1	
11	Screw, 1/4-28 x 1/4" Cup Point Socket Set	F05005-105	2	
12	Guard Weldment, Debarker Cutter Head	023628	1	
13	Bolt, 1/4-20 x 3/4" Hex Head Full Thread	F05005-1	3	
14	Nut, 1/4-20 Hex Self-Retaining	F05010-9	3	
15	Washer, 3/8" Split Lock	F05011-4	4	
16	Bolt, 3/8-16 x 1" Hex Head	F05007-7	4	
17	Bearing, 1" Flanged Mount	023541	1	
18	Bolt, 3/8-16 x 3/4" Hex Head	F05007-27	2	
19	Washer, 3/8" SAE Flat	F05011-3	2	
20	Nut, 3/8-16 Hex Nylon Lock	F05010-10	2	
21	Bushing, Blade Spacer	023632	1	
22	Blade, Complete - 180 B-06,5/5,0 D-25,5	083848-1	1	
23	Washer, Blade Lock	023737	1	
24	Bolt, 1/2-20 x 1 1/4" Hex Head Left-Hand Threads	023547	1	
25	Plate, Debarker Bottom Guard	023629	1	

6.6 Pivot Arm Assembly

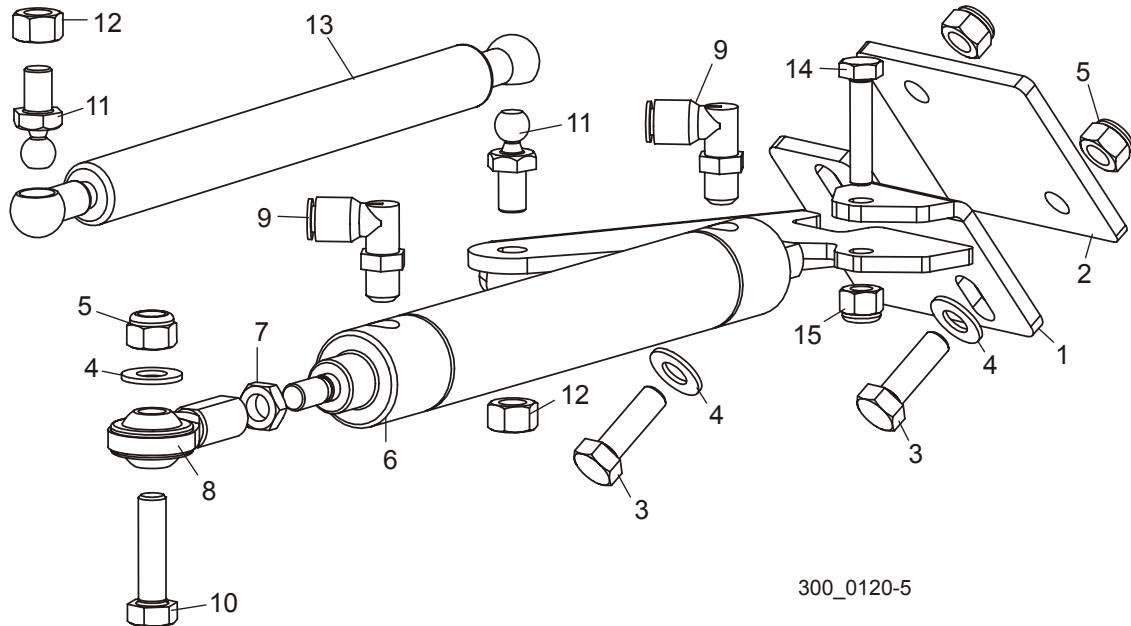

300_0120-5

REF	DESCRIPTION (◆ Indicates Parts Available In Assemblies Only)	PART #	QTY.
1	ARM WELDMENT, LT300 DEBARKER PIVOT	037606	1
2	PLATE, PIVOT ARM MOUNT	038714	1
3	BOLT, 5/16-18 X 1" HEX HEAD GRADE 5	F05006-27	2
4	WASHER, 5/16" SAE FLAT	F05011-17	3
5	NUT, 5/16-18 HEX NYLON LOCK	F05010-58	3
	CYLINDER ASSEMBLY, LT300 DEBARKER AIR	037608	1
6	Cylinder, 1 1/16" Bore x 5" Stroke Air	037607	1
7	Nut, 5/16-24 Hex Jam	F05010-119	1
8	Rod, 5/16-24 Female End	P09813	1
9	Fitting, 1/8" MPT x 1/4" Tube 90° Swivel Elbow	P09736	2
10	BOLT, 5/16-18 X 1 1/4" HEX HEAD FULL THREAD GRADE 5	F05006-93	1
11	BALL-END, 10MM X 5/16-18 X .41" STEEL	037364	2
12	NUT, 5/16-18 HEX LOCK	F05010-6	2
13	ROD, HAND CONTROL DAMPENER	044570	1
14	BOLT, 1/4-20 X 1 1/4" HEX HEAD GRADE 5	F05005-116	1
15	NUT, 1/4-20 HEX NYLON LOCK	F05010-69	1

6 Replacement Parts

Air Box Assembly

6.7 Air Box Assembly

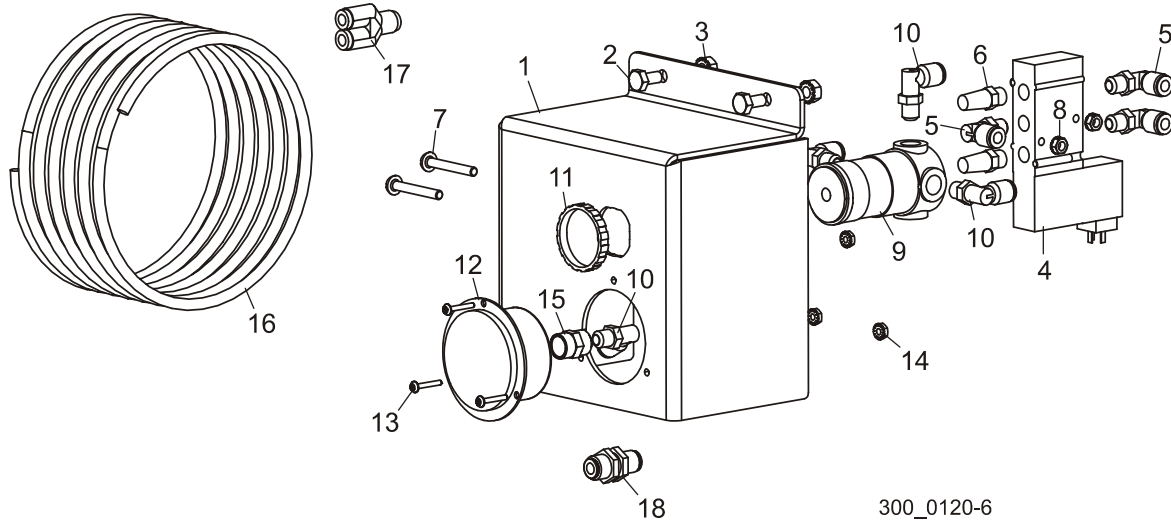

300_0120-6

REF	DESCRIPTION (◆ Indicates Parts Available In Assemblies Only)	PART #	QTY.
	BOX ASSEMBLY, LT300 DEBARKER AIR	037625	1
1	Box, Debarker Air	037622	1
2	Bolt, 1/4-20 x 1/2" Hex Head	F05005-15	2
3	Nut, 1/4-20 Self-Locking Hex	F05010-9	2
4	Valve Assembly, LT300 Debarker Air	037624	1
5	Valve, Mac 400 Series Air	025244	1
6	Fitting, 1/8" MPT x 1/4" Tube 90° Swivel Elbow	P09736	3
7	Muffler, 1/8" NPT Air	P20902	2
8	Screw, #8-32 x 1 1/2" Slotted Round Head	F05004-71	2
9	Nut, #8-32 Self-Locking Hex	F05010-41	2
10	Regulator, 1/8" NPT Air	052509	1
11	Fitting, 1/8" MPT x 1/4" Tube 90° Swivel Elbow	P09736	4
12	Nut, Regulator Mount	052510	1
13	Gauge, Air Pressure	042342	1
14	Screw, #6-32 x 3/4" Socket Button Head Stainless Steel	F05004-93	3
15	Nut, #6-32 Self-Locking Hex	F05010-59	3
16	Fitting, 1/8" FPT Coupling	P05748	1
17	Tubing, 1/4" Dia. x 12' Air	037635	1
18	Fitting, 1/4" Tube 'Y'	042546	1
18	Fitting, 1/4" Tube Bulkhead	025234	1

7 Electrical Information

Control Layout

7.2 Control Layout

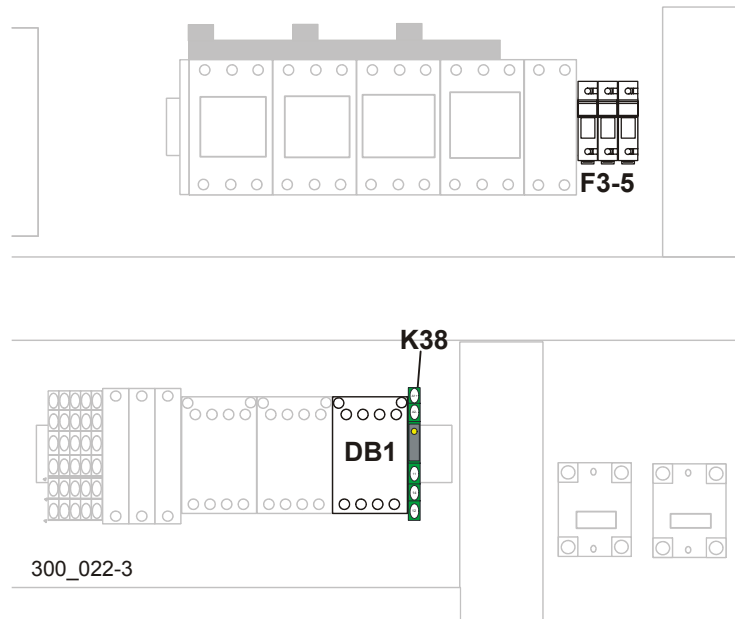

7.3 Component List				
Item	Mfg. Part No.	Mfg.	Wood-Mizer Part No.	Description
DB1	LP4D0910BD3	Square D	024890	Contactora, 3 Pole 9A 24VDC Coil
F3-F5	CCMR003	Littlefuse	052793	Fuse, 3A 600V CCMR Class CC
FS1	4KA11	Grainger	052789	Switch, Single Lever Foot
K38	2966634	Neff	024925	Relay, Solid State 24V 2A DIN
L21	411A-AoA-DM-DDA0-1KJ	Neff	025244	Valve, MAC 400 Series Solenoid
M5	PR020048/116288	Deering Ind. Sales	050292	Motor, 3/4HP 230/460 3P 1725RPM
	C60N 3P 4A (24347)		094799	Modular Switch
	ZB4-BA68		092714	Button (blue)
	ZB4-BW0B61		092717	Button Body (blue)

INDEX

A

alignment 3-1

E

electrical components 7-3

electrical information

layout 7-2

schematic 7-1

I

installation

air 2-6

debarker 2-5

electrical 2-8

LT300 Modification 2-1

M

maintenance

blade 5-2

pivot lubrication 5-1

O

operation 4-1

R

replacement parts

air box 6-9

cutting head 6-6

debarker 6-3

debarker (complete) 6-1

pivot arm 6-8

swing arm 6-4

S

safety 1-1