

# **Wood-Mizer®**

## **Remote Operation**

**Wireless Option**

**rev. A2.00**

## **Operator's Manual**



**Safety is our #1 concern!** Read and understand all safety information and instructions before operating, setting up or maintaining this machine.

*June 2007*

*Form #120*

# Table of Contents

# Section-Page

<b>SECTION 1</b>	<b>REMOTE OPERATION</b>	<b>1-1</b>
1.1	Safety Precautions .....	1-1
1.2	Wireless Control Panel Overview .....	1-2
1.3	Remote Operation.....	1-4
<b>SECTION 2</b>	<b>DIAGNOSTICS</b>	<b>2-1</b>
2.1	Test the Transmitter - Receiver Link.....	2-1
2.2	Download ID Code (Use in case of Link Test Failure).....	2-2
2.3	Calibrating Proportional Controls .....	2-5
2.4	Diagnostics - Transmitter .....	2-7
2.5	Diagnostic - Receiver .....	2-8
2.6	Troubleshooting Guide.....	2-10
<b>SECTION 3</b>	<b>SPECIFICATIONS</b>	<b>3-1</b>
<b>SECTION 4</b>	<b>PARTS LIST</b>	<b>4-1</b>
4.1	How To Use The Parts List .....	4-1
4.2	Sample Assembly .....	4-1
4.3	Wireless Kit, DC Sawmills.....	4-2
4.4	Wireless Kit, AC Sawmills.....	4-4
4.5	Wireless Kit (LES) .....	4-6
4.6	CONTROL HANGER, AC WIRELESS. (LES).....	4-7
4.7	CONTROL HANGER, AC WIRELESS. (LES).....	4-8
4.8	CONTROL HANGER, AC WIRELESS (LT40/70).....	4-10
4.9	WIRELESS KIT, LT20 AC .....	4-11

## SECTION 1 REMOTE OPERATION

### 1.1 Safety Precautions

 **WARNING!** Failure to follow the SAFETY PRECAUTIONS may result in radio equipment failure and serious personal injury

 **CAUTION!** Changes or modifications not expressly approved by the party responsible for compliance could void the user's authority to operate the equipment.

#### Installation

 **CAUTION!** PROVIDE A SAFETY CUTOFF SWITCH. If maintenance is required, the radio must be disconnected from power. USE PROPER WIRING. Loose or frayed wires can cause system failure, intermittent operation, machine damage, etc. DO NOT INSTALL IN HOT AREAS. This apparatus can be damaged by heat in excess of 158 F (70° C)

#### Personal Safety

 **CAUTION!** MAKE SURE MACHINERY AND SURROUNDING AREA IS CLEAR BEFORE OPERATING. Do not activate the remote system unless it is safe to do so.

 **CAUTION!** TURN OFF THE RECEIVER POWER BEFORE WORKING ON SAWMILL. Always disconnect the remote system before doing any maintenance to prevent accidental operation of the machine

#### Care

 **CAUTION!** KEEP DRY. Do not clean the transmitter / receiver under high pressure. If water or other liquids get inside the transmitter battery or receiver compartment, immediately dry the unit. Remove the case and let the unit air dry

 **CAUTION!** CLEAN THE UNIT AFTER OPERATION. Remove any mud, dirt, concrete, etc. from the unit to prevent clogging of buttons, switches, etc. by using a damp cloth.

# 1 Remote Operation

## Wireless Control Panel Overview

### Maintenance / Welding



**CAUTION!** DISCONNECT THE RADIO RECEIVER BEFORE WELDING on the machine the receiver is connected to. Failure to disconnect will result in the destruction of the radio receiver.

## 1.2 Wireless Control Panel Overview

LT70 sawmills can be equipped with saw head remote control system (with wireless control panel). This system allows you to fully control the saw head, i.e. engage and disengage the blade, control the power and up/down feed, the blade guide arm and the debarker as well as to adjust the feed rate.

See Figure 1-1. Wireless control panel functions (DC).

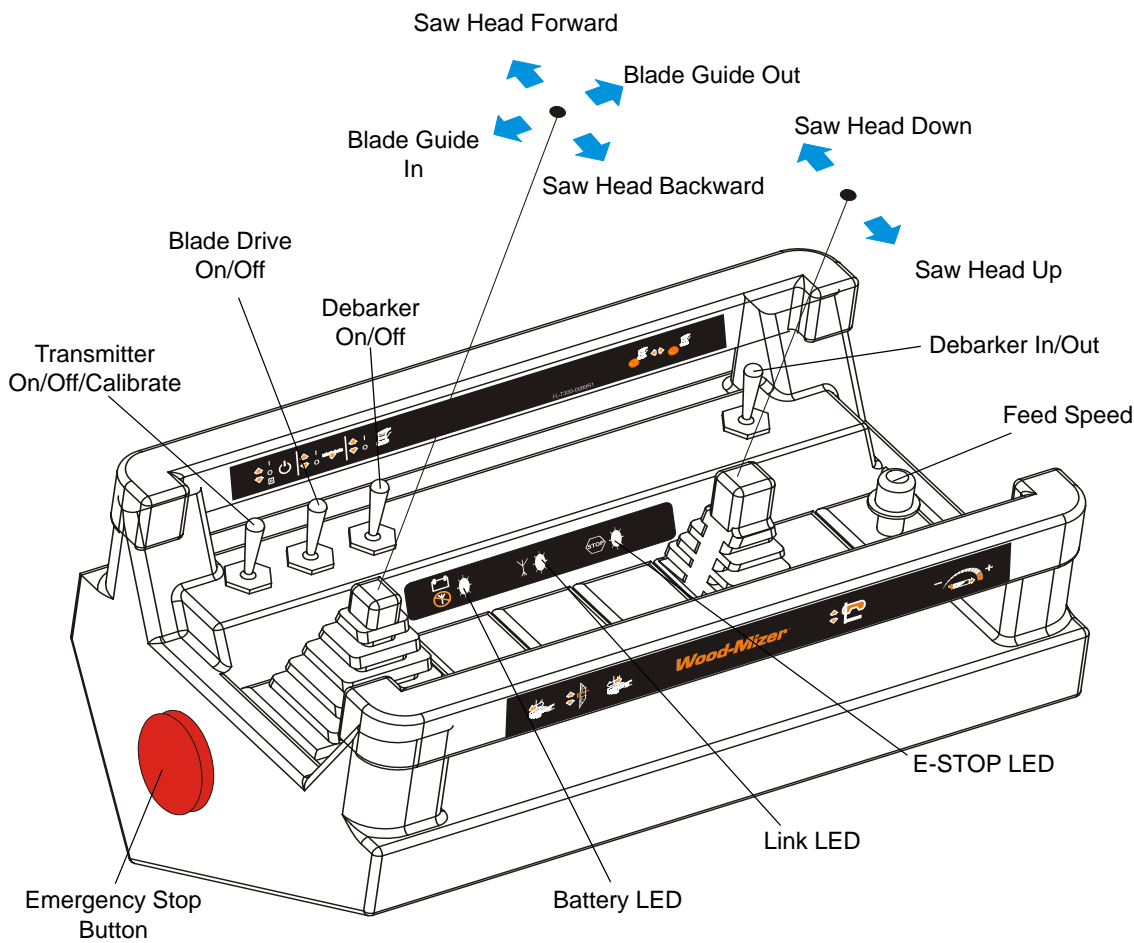

See Figure 1-2. Wireless control panel functions (AC).

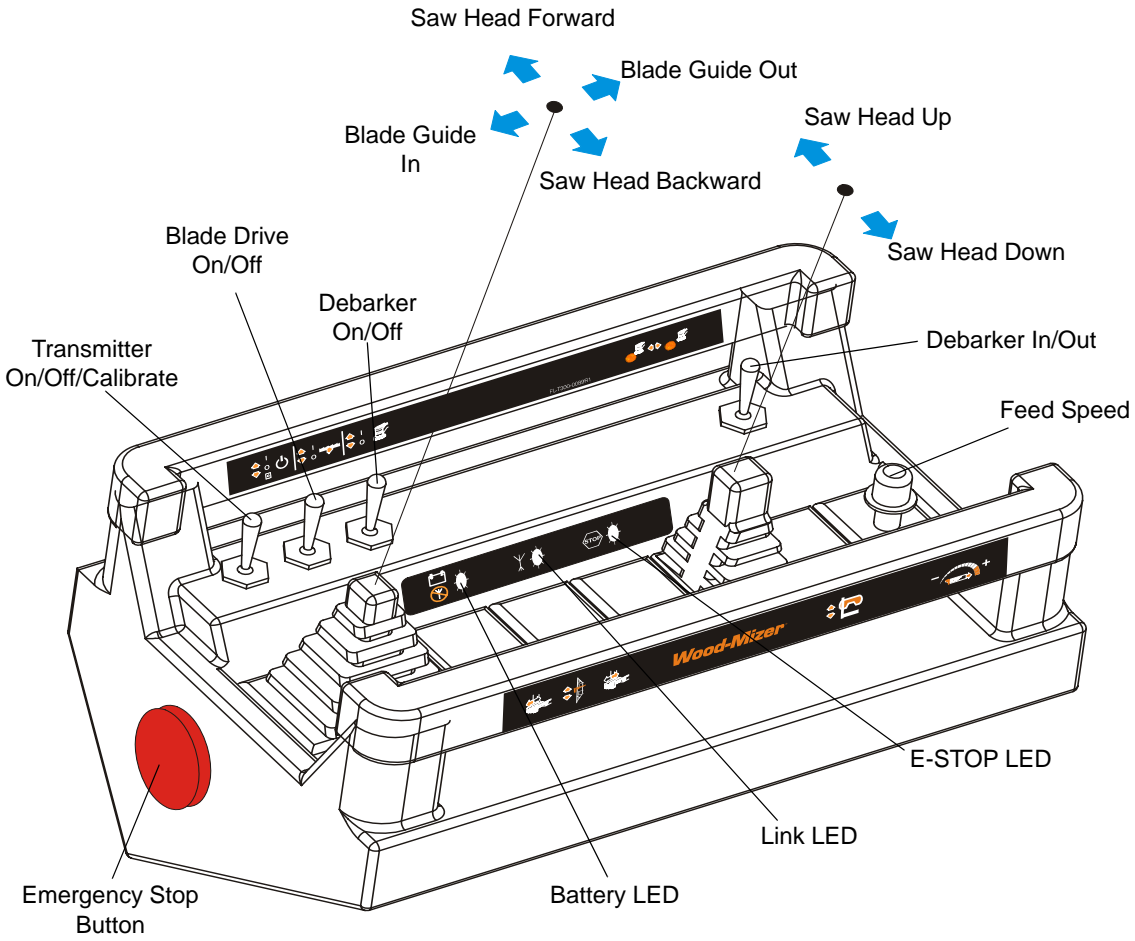

# 1 Remote Operation

## Remote Operation

### 1.3 Remote Operation

Set up the sawmill as instructed in your sawmill operator's manual.

#### Install the batteries in the transmitter

Batteries are installed in the transmitter by removing the battery cover using a slotted screwdriver and inserting 4 "LR14 SIZE C" alkaline batteries. Orientation of the batteries is embossed inside the battery housing.

**NOTE:** For operation at temperatures below -10 C lithium batteries are recommended. Low temperatures reduce battery performance for both alkaline and lithium types. Refer to the battery manufacturer's specifications for detailed information on low temperature performance.

#### To turn the wireless panel on:

- Ensure all transmitter switches and joysticks are in the neutral or OFF position.
- Turn on the transmitter by pressing and releasing the [Power] switch. The RED (E-Stop) light will flash quickly. Release the [E-Stop], the yellow (Active) light on the transmitter will begin to flash.<sup>1</sup>

Press the E-Stop

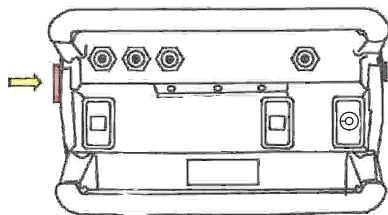

Press and release Power switch

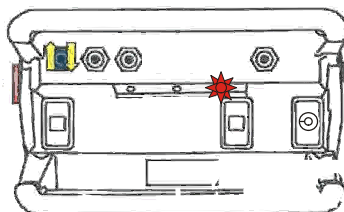

Turn Clockwise & Release E-Stop

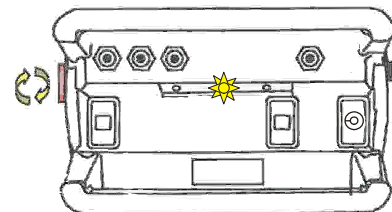

#### To engage the blade drive (AC):

- Push the [Power] switch to ON position;
- Push the [Blade] switch to ON position;

1.

Light Legend	Solid	Slow Flash	Fast Flash	Red Flash	Green Flash	Yellow Flash	Alternating Red & Green Light

The blade drive will be engaged. Next push the power feed joystick forward the saw head will move forward. Use the Feed Speed switch to adjust the speed of saw head movement.

**To engage the blade drive (DC):**

- Ensure that the key switch is in OFF position.
- Turn the green switch located on the wireless receiver box to ON position.
- Start the engine using key switch.
- Push the [Blade] switch to ON position;
- Push the power feed joystick forward.

The blade drive will be engaged and, after 2 seconds, the saw head will move forward. Use the Feed Speed switch to adjust the speed of saw head movement.

**NOTE:** If you release the joystick the blade drive will be disengaged. To engage once again you have to switch the blade drive switch to OFF and next to ON position.



**NOTE:** If the green switch located on the wireless receiver box is turned to OFF position, the wireless option is completely disconnected and all functions are controlled by the standard control panel mounted on the saw head.

**Cutting with wireless control system:**

- Load and clamp the log;
- Program the Accuset (or PLC-Setworks or SW-10) controller ([See the Accuset, PLC-Setworks or SW-10 manual](#));
- Position the saw head on the height of the first cut;
- Turn the debarker on, if needed;
- Push the left joystick forward to engage the blade drive and move the saw head forward, use the feed speed dial to adjust the feed speed;
- Push the right joystick inward to move the saw head over the cutting log (Bump Up);
- Back the saw head to the beginning of the log;
- Push the right joystick forward to lower the saw head to the next cut position;
- Move the Blade drive switch to OFF and next to ON position;
- Push the left joystick forward to engage the blade drive and move the saw head forward.
- Make the next cut.



## SECTION 2 DIAGNOSTICS

### 2.1 Test the Transmitter - Receiver Link

Follow this steps to ensure that there is a Radio Link between the transmitter and receiver.

Refer to the Light Legend below for diagram details.<sup>1</sup>

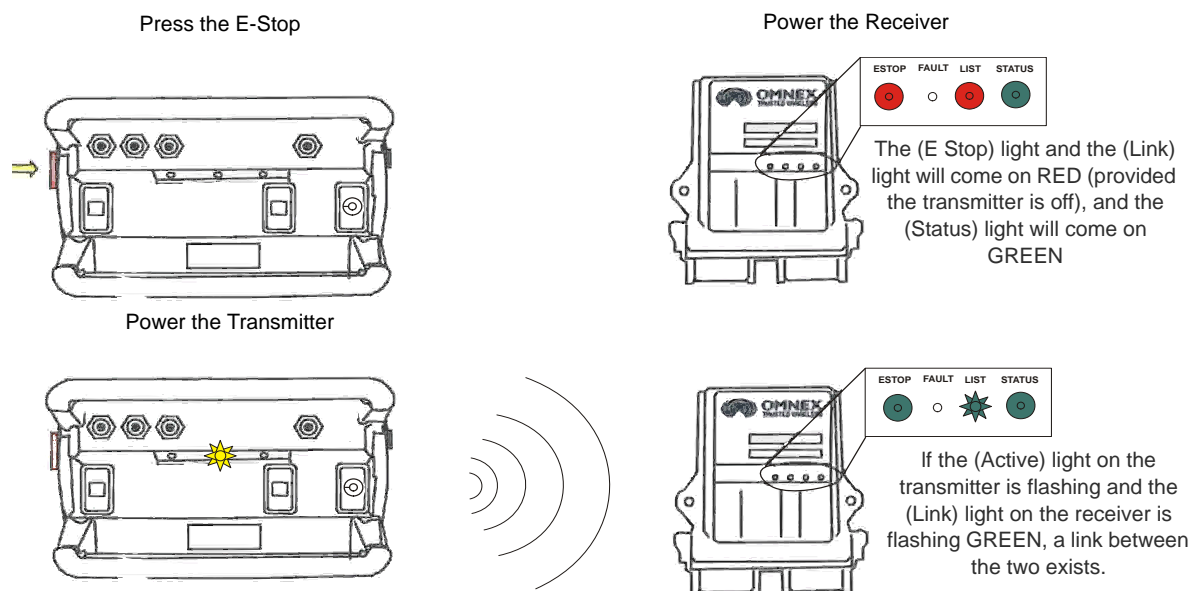

**NOTE:** The transmitter will shut itself off (and the receiver will then shut off all outputs) after 10 minutes of inactivity as a battery saving feature. To restart the timer before the transmitter shuts off automatically, momentarily operate any switch or joystick.

The Wireless System is now ready for use.,

If the receiver's (Link) light does not become GREEN follow the steps under **Download ID Code.**

1.

Light Legend	Solid	Slow Flash	Fast Flash	Red Flash	Green Flash	Yellow Flash	Alternating Red & Green Light

## 2.2 Download ID Code (Use in case of Link Test Failure)

Follow these steps to download the transmitter's unique ID Code into the receiver. This will allow the receiver to establish a Radio link with a specific transmitter. Refer to **Troubleshooting Chart #4** for Tips and Considerations

**NOTE:** It is necessary to download the ID code when replacing either the transmitter or the receiver.

### Opening the receiver case

The cap is held on by two plastic tabs at opposing sides, which can be unlatched as shown using a screwdriver. Once the cap is free, the receiver can slide open.

Use a small slotted screwdriver to press the Side Tabs inward.

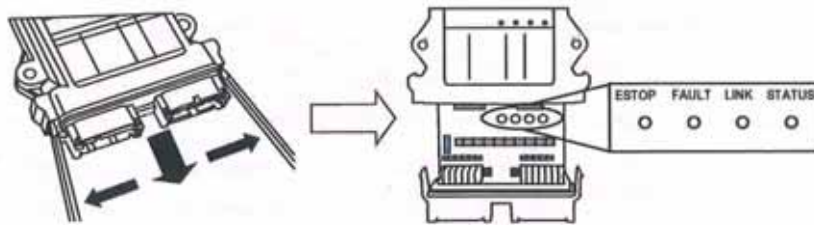

**NOTE:** When replacing the receiver cover, ensure the cover snaps completely into place to create a weather proof seal around the base of the receiver.

### Prepare the transmitter

- Press [E-Stop]
- Twist clockwise & release [E-Stop]

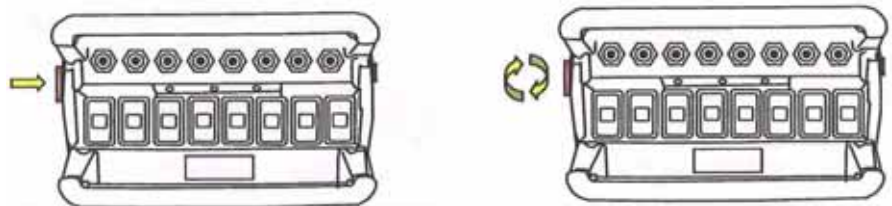

### Power the transmitter

- Supply power to the receiver. The (E-Stop) light and the (Link) light will come on RED and the (Status) light will come on GREEN.<sup>1</sup>

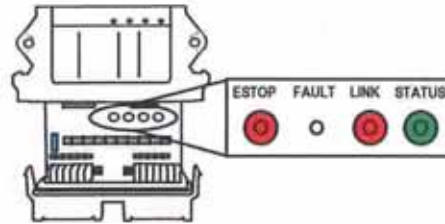

**NOTE:** For this procedure, orientation of the joysticks and switch operation will be defined as follows: Joystick UP is towards the switches. Joystick DOWN is away from switches. Switch UP is away from joysticks. Switch DOWN is towards the joysticks.

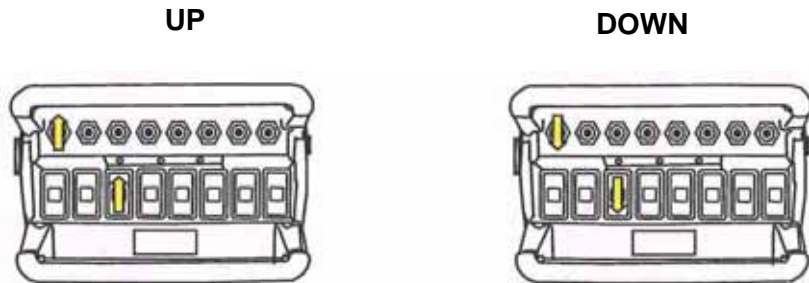

**Power Transmitter into Configuration Mode**

- Hold [Power] switch UP
- Press [E-Stop]
- Twist CW & release [E-Stop]
- Release [Power] Switch

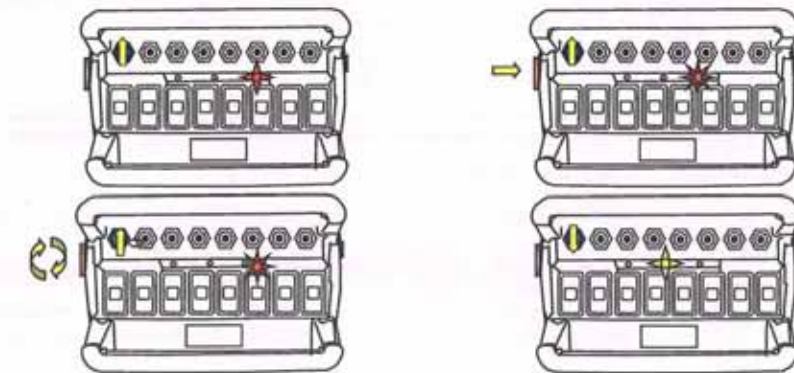

**Put the receiver into Setup Mode**

1.

Light Legend	Solid	Slow Flash	Fast Flash	Red Flash	Green Flash	Yellow Flash	Alternating Red & Green Light

## 2 Diagnostics

### Download ID Code (Use in case of Link Test Failure)

- Press & hold [Setup] button until (Status) light goes from slow flash to fast flash<sup>1</sup>

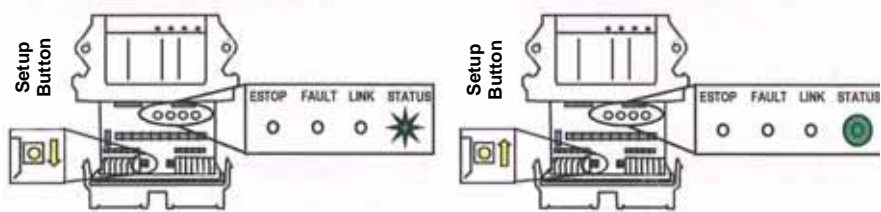

- Release [Setup] button. (Status) light goes to solid GREEN, (Link) light turns off

**NOTE:** If left idle in Setup Mode for over 30 seconds, the receiver will time out. The (Link) light and (Status) light will flash RED rapidly. To return to Setup Mode, repeat step 5.

### Download ID Code

**NOTE:** When downloading a new ID to a receiver, a safety feature requires that the transmitter be in close proximity to the receiver. This will prevent a transmitter from accidentally reprogramming a different receiver in the area.

- Press [Power] switch UP and release
- (Link) light goes to GREEN. Once complete, (Link) light goes to RED.

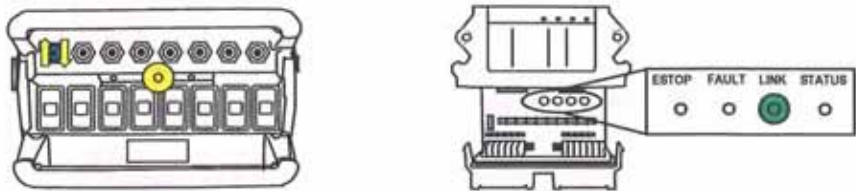

1.

Light Legend	Solid	Slow Flash	Fast Flash	Red Flash	Green Flash	Yellow Flash	Alternating Red & Green Light

## 2.3 Calibrating Proportional Controls

The transmitter's Joysticks and Potentiometers control the receiver's proportional output. The Paddles/Joysticks are used in conjunction with any of the transmitter's switches. The proportional output can be activated when a switch is held UP or DOWN; it will become active at an increasingly high level as the Paddle/Joystick is pushed/pulled, or a potentiometer is adjusted. The minimum and maximum levels of the proportional output can be calibrated by following these steps. Refer to the **Light Legend** below for diagram details<sup>1</sup>.

**NOTE:** Calibration settings can be reset to factory default in steps 3 & 4 by holding the [Power] switch UP or DOWN for 5 seconds.

### 1. Power transmitter and receiver

- Refer to steps in "Power the Transmitter"
- Supply power to the R160

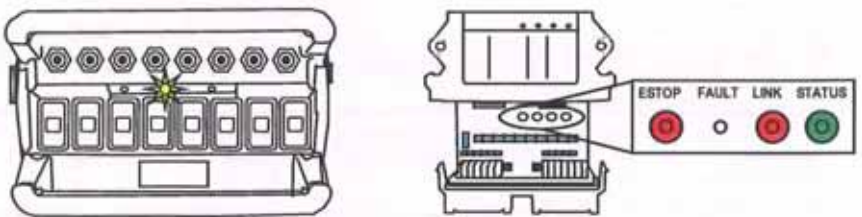

### 2. Setup transmitter into Configuration Mode

- Hold [Power] switch DOWN for 5 seconds until the (Battery) LED goes to alternating RED and YELLOW.

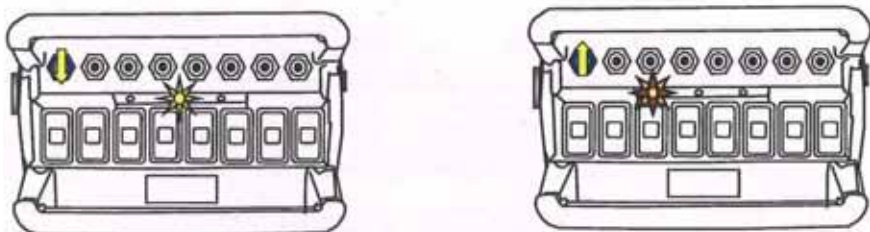

- Release [Power] switch

### 3. Set Minimum Level

- Push the paddle (or turn the potentiometer) in the direction you wish to calibrate until the (Active) LED comes on<sup>2</sup>

1.

Light Legend	Solid	Slow Flash	Fast Flash	Red Flash	Green Flash	Yellow Flash	Alternating Red & Green Light

# 2

## Diagnostics

### Calibrating Proportional Controls

- Hold paddle and Press [Power] switch DOWN to increase minimum level or UP to decrease it

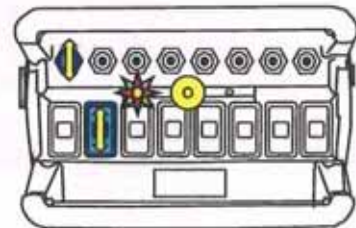
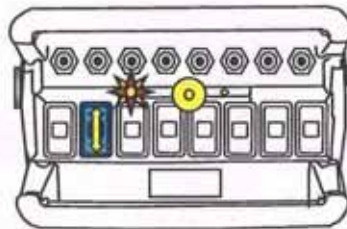

#### 4. Set Maximum Level

- Fully push the paddle (function) (or turn the potentiometer) in the direction you wish to calibrate until the (E-Stop) LED comes on.

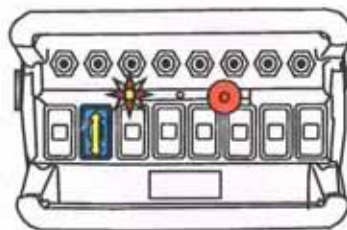

B.

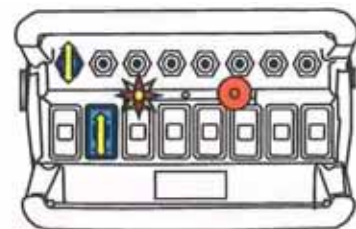

- Hold paddle and Press [Power] switch DOWN to increase maximum level or UP to decrease it

**Note:** Repeat steps 3 and 4 for each paddle (function) that needs to be calibrated.

#### 5. Power Off



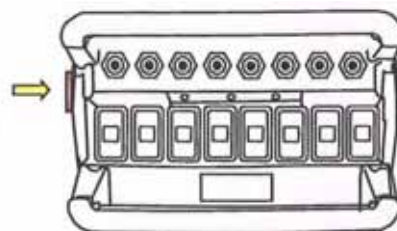

- Press [E-Stop]





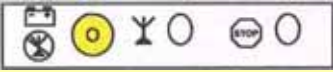
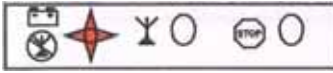
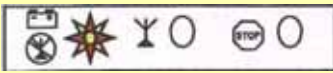

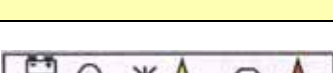
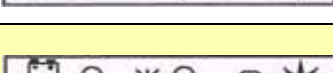
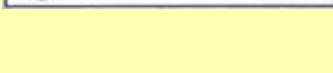

2.

Light Legend	Solid	Slow Flash	Fast Flash	Red Flash	Green Flash	Yellow Flash	Alternating Red & Green Light

## 2.4 Diagnostics - Transmitter

	Tether connection detected
	Low battery. Unit will run approximately 20 hours after battery light starts flashing.
	The transmitter is in Calibration mode
	Power switch is stuck in the "UP" position.
	The Active light remain on momentarily when a function is activated (i.e. a switch or paddle is triggered). This is normal operation.
	<b>Normal Operation</b> The transmitter is in Download Mode.
	<b>Normal Operation</b> The Active light will flash 2 times per second, indicating that the transmitter is sending signals to the receiver.
	Stuck switch detected. Ensure that all switches are in a centered position. The transmitter will not power up when a function is ON.
	<b>On Power Up</b> Release the E-Stop button within 10 seconds to power up the transmitter, or the unit will power down.
	<b>On Power Up</b> Press and release the E-Stop button within 10 seconds to power up the transmitter, or the unit will power down.

1

<b>Light Legend</b>	Solid 	Slow Flash 	Fast Flash 	Red Flash 	Green Flash 	Yellow Flash 	Alternating Red & Green Light 
---------------------	---	--	--	---	---	--	---

## 2 Diagnostics

### Diagnostic - Receiver

## 2.5 Diagnostic - Receiver

### Normal Operation







	<p>Transmitter is OFF If the transmitter is off, the receiver is operating properly</p>
	<p>Transmitter is ON When the transmitter is turned on, the Link light (fast flashing) and E-Stop (GREEN) indicates the receiver is operating properly</p>
	<p>Transmitter is in Operation When a function is activated on the transmitter, the Fault light will turn on GREEN. This indicates the receiver is operating properly</p>
	<p>Transmitter is OFF When a latched function is activated then the transmitter is turned off, the Fault light will stay on GREEN. If the system was intentionally designed this way, the receiver is operating properly, if not call for service.</p>

### Trouble Indicators

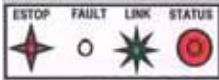



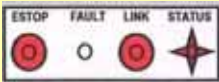
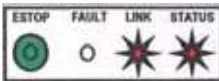

**NOTE:** In some cases, the indicator lights will be different depending on whether the transmitter is on or off. Please note the transmitter status in the "Description" column for each case.

Indicator Lights	Description	Solution
	<p>Transmitter is ON The reason is the transmitter is not communicating with the receiver.</p>	<p>Refer to <b>Troubleshooting Chart #3</b> for solutions</p>
	<p>Transmitter is ON A low battery condition <u>has been detected</u>.</p>	<p>To detect intermittent conditions caused by poor or corroded ground or power circuits, the GREEN light will continue to flash for 30 seconds after the condition has been removed<sup>1</sup></p>



	<p>Transmitter is ON An internal fault with the E-Stop has been detected.</p>	<p>Inspect E-Stop wiring for short circuit. Disconnect E-Stop wire as close to the receiver output as possible. If the Status light changes to:</p> <ul style="list-style-type: none"> <li>- GREEN, a short occurs after disconnection point.</li> <li>- Stays flashing RED, send it in for service.</li> </ul>
	<p>Transmitter is ON A short to ground or excessive current draw on an output. It is most likely caused by a wiring fault.</p>	<p>Ensure transmitter is functioning properly, check status of each output connection: Press each function button and observe Fault Light.</p> <ul style="list-style-type: none"> <li>- If GREEN, everything is OK.</li> <li>- If RED, there is a short in that connection.</li> </ul>
	<p>Transmitter is ON The E-Stop output has been connected with one of the other outputs</p>	<p>Follow the wire and check for connections with other wires, disconnect to see if condition clears. If not, call for service.</p>
	<p>Transmitter is OFF A wiring short to the battery has been detected.</p>	<p>Refer to <b>Troubleshooting Chart #1</b> for solutions</p>
	<p>Transmitter is OFF The receiver has detected an internal fault.</p>	<p>Refer to <b>Troubleshooting Chart #1</b> for solutions</p>
	<p>Transmitter is OFF Blown fuse detected.</p>	<p>Refer to <b>page 2</b> for instructions on how to open the receiver case to access fuse. Check wiring for shorts or bare spots. If fuses continue to blow, call for service.</p>
	<p>Transmitter is ON A setup failure has occurred.</p>	<p>Either hold the Setup button for 5 seconds to return to Setup mode or cycle power to return to the normal operating mode.</p>
	<p>Transmitter is OFF The receiver is powered incorrectly.</p>	<p>Most likely cause of this condition is that an output wire or the E-Stop wire has been connected to the power supply while the power wire is disconnected from the power supply.</p>

1

Light Legend	Solid 	Slow Flash 	Fast Flash 	Red Flash 	Green Flash 	Yellow Flash 	Alternating Red & Green Light 
--------------	---	--	--	---	---	--	---

## 2.6 Troubleshooting Guide

**Chart #1 Test the Receiver**

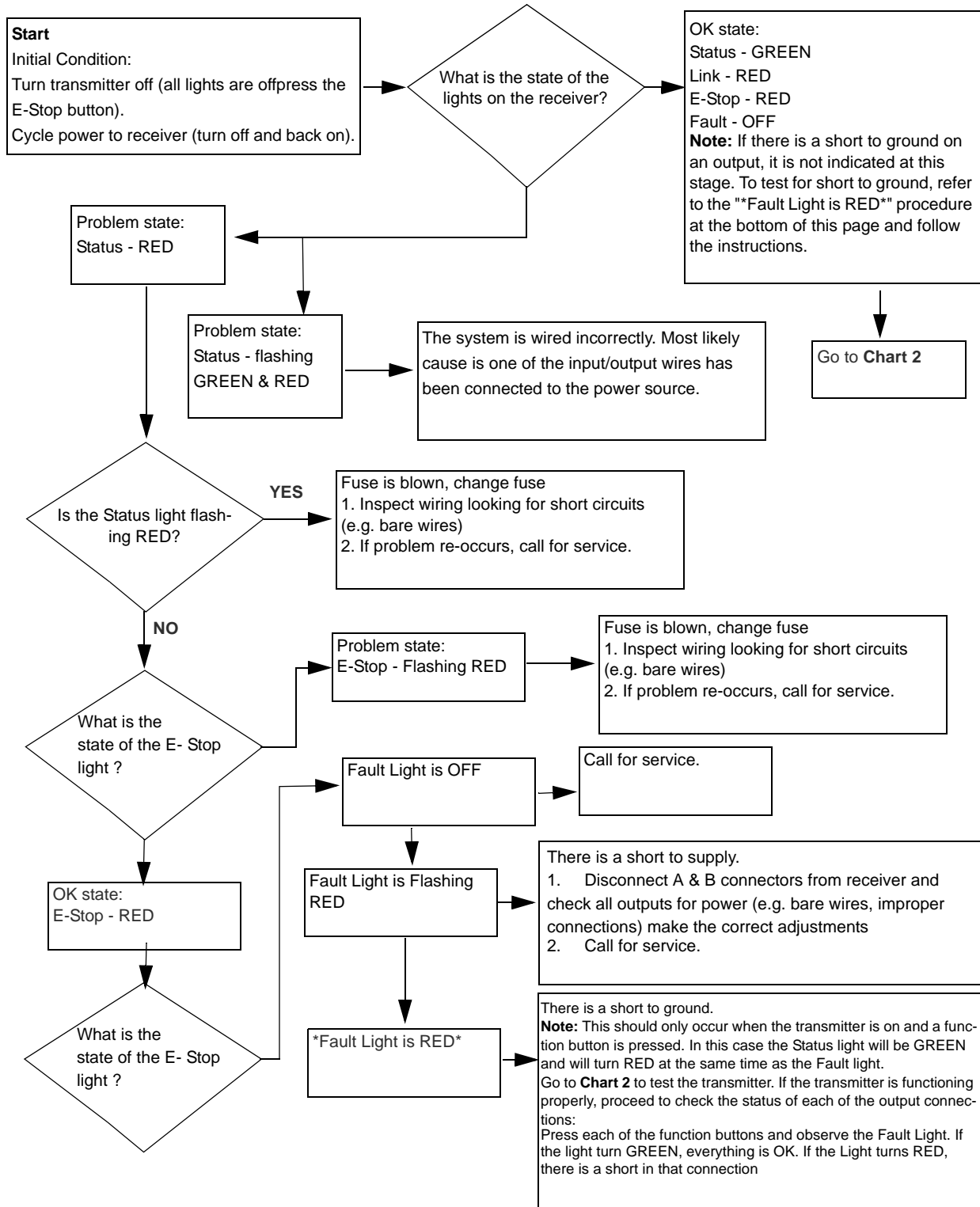

**Chart #2 Test the Transmitter**

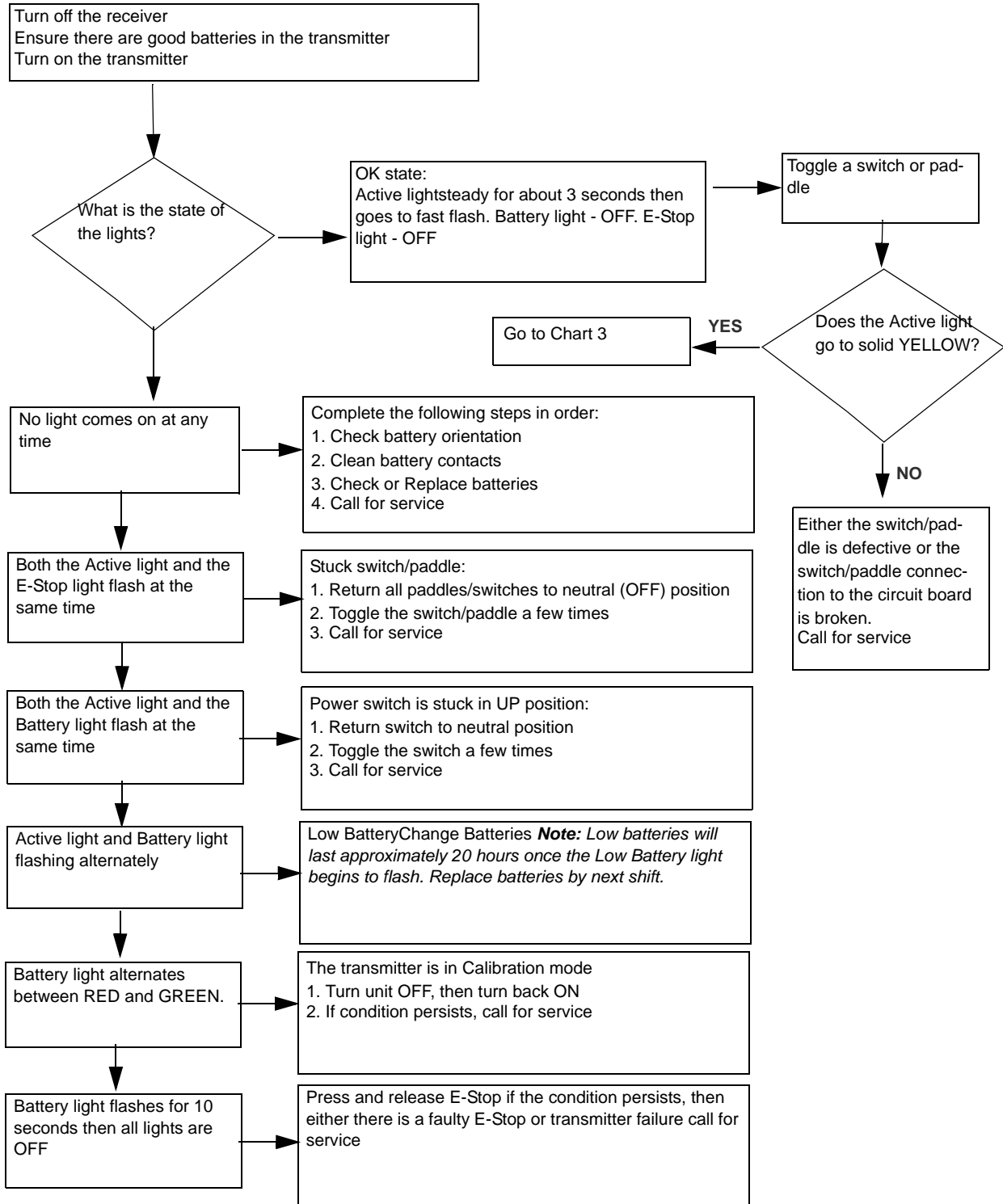

**Chart #3 Testing the Transmitter / Receiver Communication**

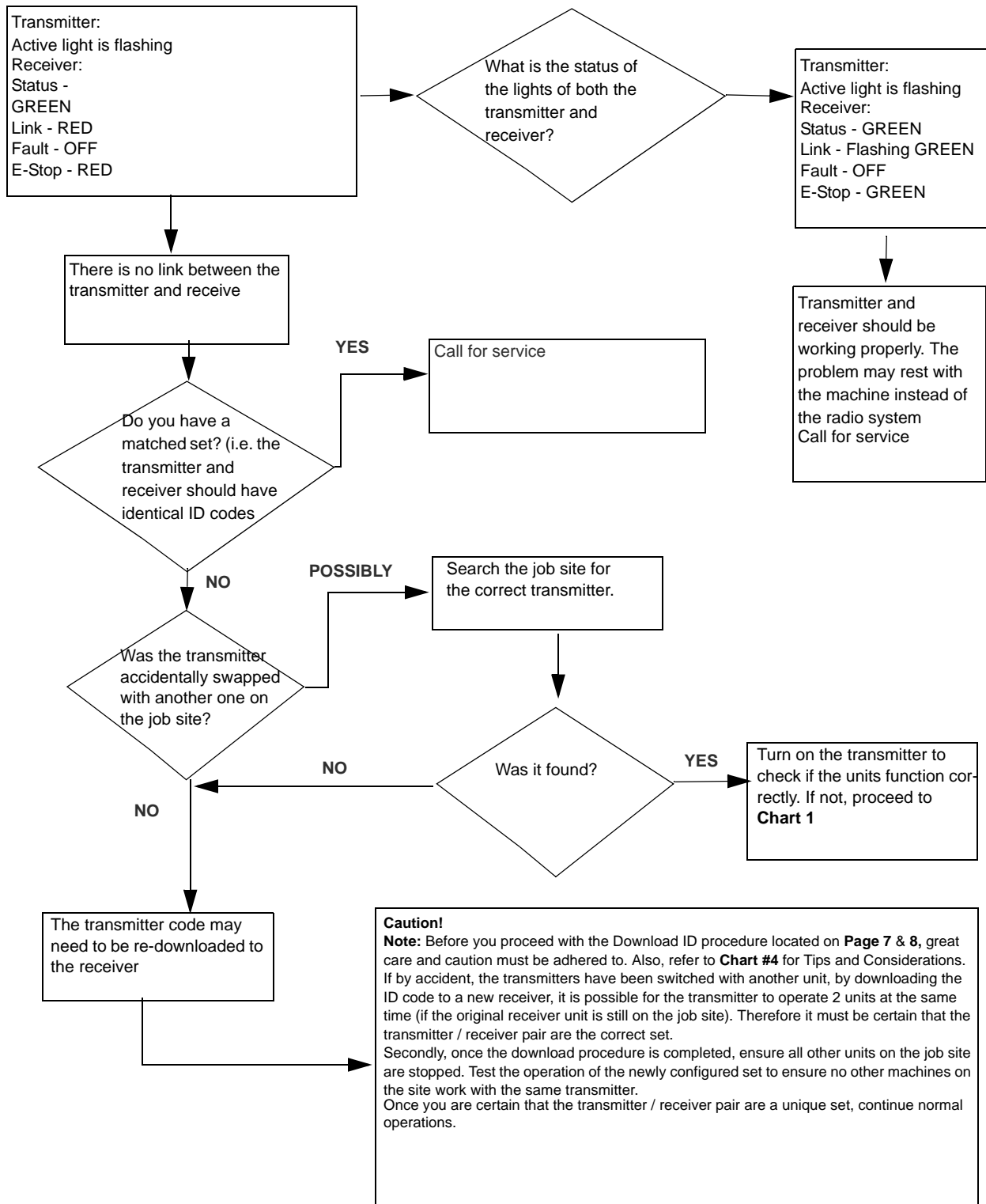

## Chart #4 Considerations when Downloading the ID

### Potential downloading issues

If testing of the receiver and transmitter both show the system as working (Chart 1 & 2), then the transmitter and receiver will both go into Download/Configuration mode.

Possible issues could arise during Step 4, the download phase of reprogramming. In this case there are 2 symptoms to look for:

1. The Link light on the receiver will not turn GREEN when the power switch is toggled on the transmitter to download
2. The receiver will "time out" indicating that it didn't receive a signal from the transmitter within the 30 seconds from the time the receiver was put into Setup Mode.

If all indications appear normal during the download phase, test the link by turning on the transmitter (note: the transmitter shuts off after transmitting the ID code in Step 4)

1. If the Link light on the receiver doesn't turn GREEN, the receiver didn't receive all of the information that was sent from the transmitter.

### Possible Solutions

1. Try the Downloading steps again
2. If this doesn't correct the problem, send both the transmitter and receiver in for service.

Note: you could try to determine whether the fault lies with the transmitter or receiver by completing the downloading procedure with a different transmitter. If this step works, then the fault lies with the original transmitter. If not, the fault may lie with the receiver.



**CAUTION!** Before attempting downloading with another transmitter, understand that reprogramming the receiver with another transmitter, could result in two receivers on the job site responding to the one transmitter. If the original transmitter was sent in for repair, Disconnect the receiver (disconnect connector A) to continue using the machine without remote capability and without fear of inadvertently operating the machine with the other transmitter.

**Reprogramming Tips:**

1. Use a pointy instrument to depress the Setup button on the receiver (i.e. a pen) as the button is relatively small
2. Follow each step as laid out in the procedure
3. Never lay the receiver circuit board down on anything metallic (there are contact points on the back which could contact the metal and damage the receiver).

## SECTION 3 SPECIFICATIONS

	Receiver	Transmitter
<b>Size</b>	130mm x 119mm x 36mm	240mm x 152mm x 127mm
<b>Weight</b>	0.295kg	1.2kg (incl. batteries)
<b>Construction</b>	High impact plastic, weatherproof	High impact, low temperature plastic, weatherproof
<b>Input Power</b>	+9V to 30VDC	4C alkaline batteries
<b>Battery Life</b>	N/A	500 hours (continuous use)
<b>Operating Temperature Range</b>	-40°C to 70°C	-40°C to 60°C
<b>Outputs</b>	3A (max) each, 10A (max, combined)	N/A
<b>Antenna</b>	Internal	
<b>Approvals</b>	Europe- EN 440, USA -FCC part 15.247	
<b>Range</b>	~250m	

## SECTION 4 PARTS LIST

### 4.1 How To Use The Parts List

- Use the index above to locate the assembly that contains the part you need.
- Go to the appropriate section and locate the part in the illustration.
- Use the number pointing to the part to locate the correct part number and description in the table.
- Parts shown indented under another part are included with that part.
- Parts marked with a diamond (◆) are only available in the assembly listed above the part.

See the sample table below. Sample Part #A01111 includes part F02222-2 and subassembly A03333. Subassembly A03333 includes part S04444-4 and subassembly K05555. The diamond (◆) indicates that S04444-4 is not available except in subassembly A03333. Subassembly K05555 includes parts M06666 and F07777-77. The diamond (◆) indicates M06666 is not available except in subassembly K05555.

4.2 Sample Assembly				
REF	DESCRIPTION (◆ Indicates Parts Available In Assemblies Only)	PART #	QTY.	
	Sample Assembly, Complete (Includes All Indented Parts Below)	A01111	1	
1	Sample Part	F02222-22	1	
	Sample Subassembly (Includes All Indented Parts Below)	A03333	1	
2	Sample Part (◆ Indicates Part Is Only Available With A03333)	S04444-4	1	◆
	Sample Subassembly (Includes All Indented Parts Below)	K05555	1	
3	Sample Part (◆ Indicates Part Is Only Available With K05555)	M06666	2	◆
4	Sample Part	F07777-77	1	

#### **To Order Parts:**

- From Europe call our European Headquarters and Manufacturing Facility in Kolo, Poland at **+48-63-2626000**. From the continental U.S., call our toll-free Parts hotline at **1-800-448-7881**. Have your customer number, vehicle identification number, and part numbers ready when you call.

From other international locations, contact the Wood-Mizer distributor in your area for parts.



### 4.3 Wireless Kit, DC Sawmills

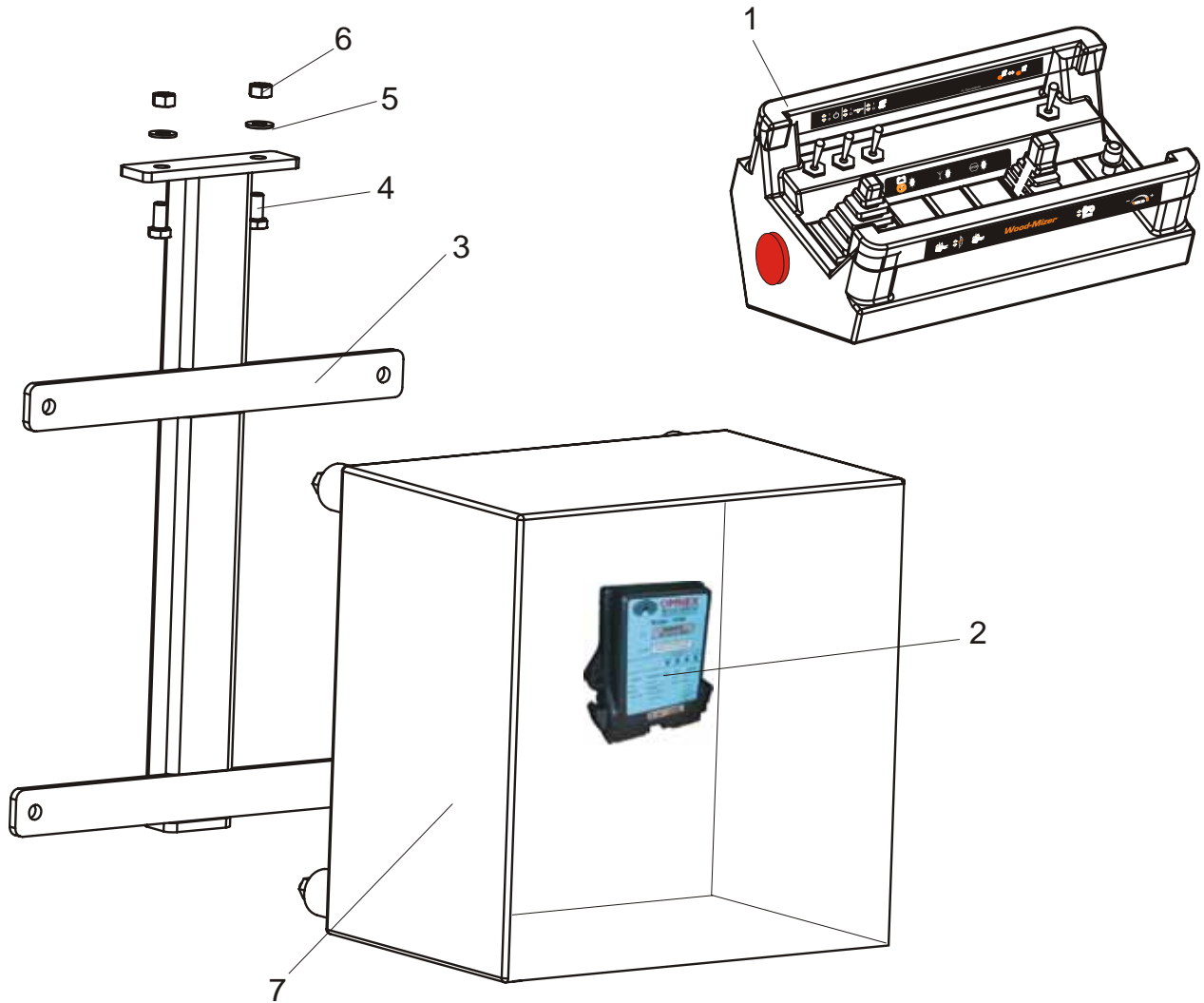

REF	DESCRIPTION (◆ Indicates Parts Available In Assemblies Only)	PART #	QTY.
	<b>WIRELESS CONTROL SYSTEM, DC SAWMILLS</b>	097803	1
	INTERFACE OMNEX DC	505387	1
	RELAY55.34.9.012.00.0 FINDER	091951	1
	RELAY, RM84 2012-35-1012 RELPOL	084314	1
	WIRELESS REMOTE CONTROL	505392	1
1	TRANSMITTER	083713	1
2	RECEIVER	083714	1
3	BRACKET, WIRELESS JUNCTION BOX	096930-1	1
4	BOLT M8X16 -8.8-B-FE/ZN5	F81002-20	2
5	WASHER, M8, FLAT, ZINC	F81054-1	2

**4****Parts List***Wireless Kit, DC Sawmills*

---

6	NUT, M8 HEXAGON, GRADE 5.8 FREE ZINC	F81032-1	2	
	POTENTIOMETER 2,5K 53C3-2500 KIT	505385-S	1	
	RESISTOR 600R/0,5W	505386	1	
	RESISTOR 180R/0.5W	506224	1	
	BATTERY, ALKALINE R14	098174	4	
	GLAND, Pg 21 CABLE	F81096-3	1	
	DIODE, 1N4007	087497	1	

### 4.4 Wireless Kit, AC Sawmills

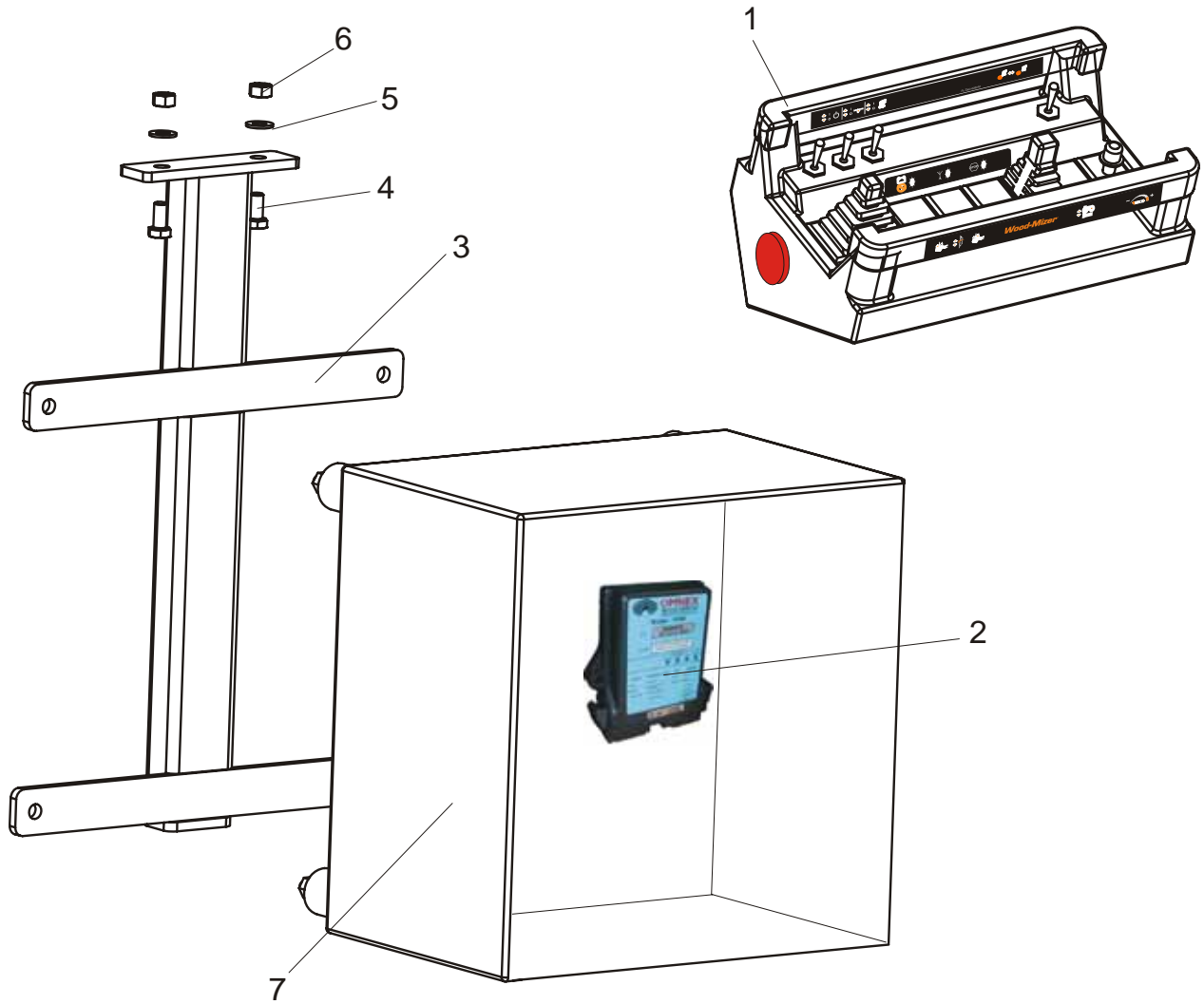

REF	DESCRIPTION (◆ Indicates Parts Available In Assemblies Only)	PART #	QTY.	
	<b>WIRELESS CONTROL SYSTEM, AC SAWMILLS</b>	097804	1	
	INTERFACE OMNEX DC	097773	1	
	WIRELESS REMOTE CONTROL	505393	1	
1	TRANSMITTER	083716	1	
2	RECEIVER	083715	1	
3	BRACKET, WIRELESS JUNCTION BOX	096930-1	1	
4	BOLT M8X16 -8.8-B-FE/ZN5	F81002-20	2	
5	WASHER, M8, FLAT, ZINC	F81054-1	2	
6	NUT, M8 HEXAGON, GRADE 5.8 FREE ZINC	F81032-1	2	
	POTENCJOMETR 2,5K 53C3-2500 KIT	505385-S	1	

**4****Parts List***Wireless Kit, AC Sawmills*

---

	REZYSTOR 600R/0,5W	505386	1	
	REZYSTOR 180R/0.5W	506224	1	
	BATTERY, ALKALINE R14	098174	4	
	GLAND, Pg 21 CABLE	F81096-3	1	
	FITTING, ELZ-4	F81086-1	1	
	TERMINAL, Hix1.5 CORD-END	F81083-4	1	

### 4.5 Wireless Kit (LES)

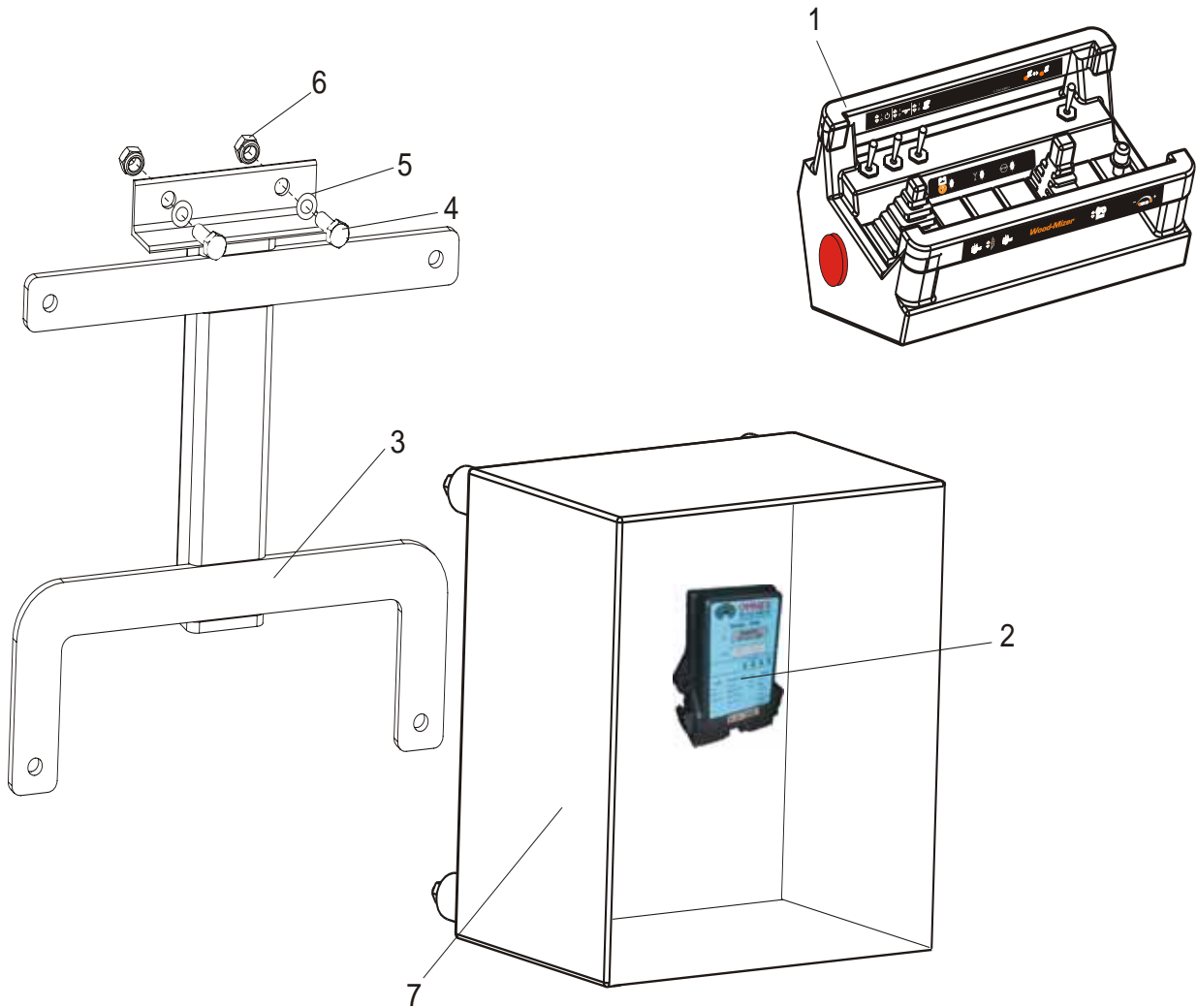

REF	DESCRIPTION (◆ Indicates Parts Available In Assemblies Only)	PART #	QTY.
	<b>WIRELESS CONTROL SYSTEM, AC SAWMILLS</b>	501442	1
	INTERFACE OMNEX AC	097773	1
	RELAY55.34.9.012.00.0 FINDER	091951	1
	RELAY 12V DC 40.52 FINDER	084314	1
	WIRELESS REMOTE CONTROL	097314	1
1	TRANSMITTER T300	098903	1
2	RECEIVER R160	098904	1
3	BRACKET, WIRELESS JUNCTION BOX	100710-1	1
4	BOLT M8X16 -8.8-B-FE/ZN5	F81002-20	2
5	WASHER, M8, FLAT, ZINC	F81054-1	2

# 4

## Parts List

### CONTROL HANGER, AC WIRELESS. (LES)

6	NUT, M8 HEXAGON, GRADE 5.8 FREE ZINC	F81032-1	2	
7	INTERFACE OMNEX AC	097993	1	

## 4.6 CONTROL HANGER, AC WIRELESS. (LES)

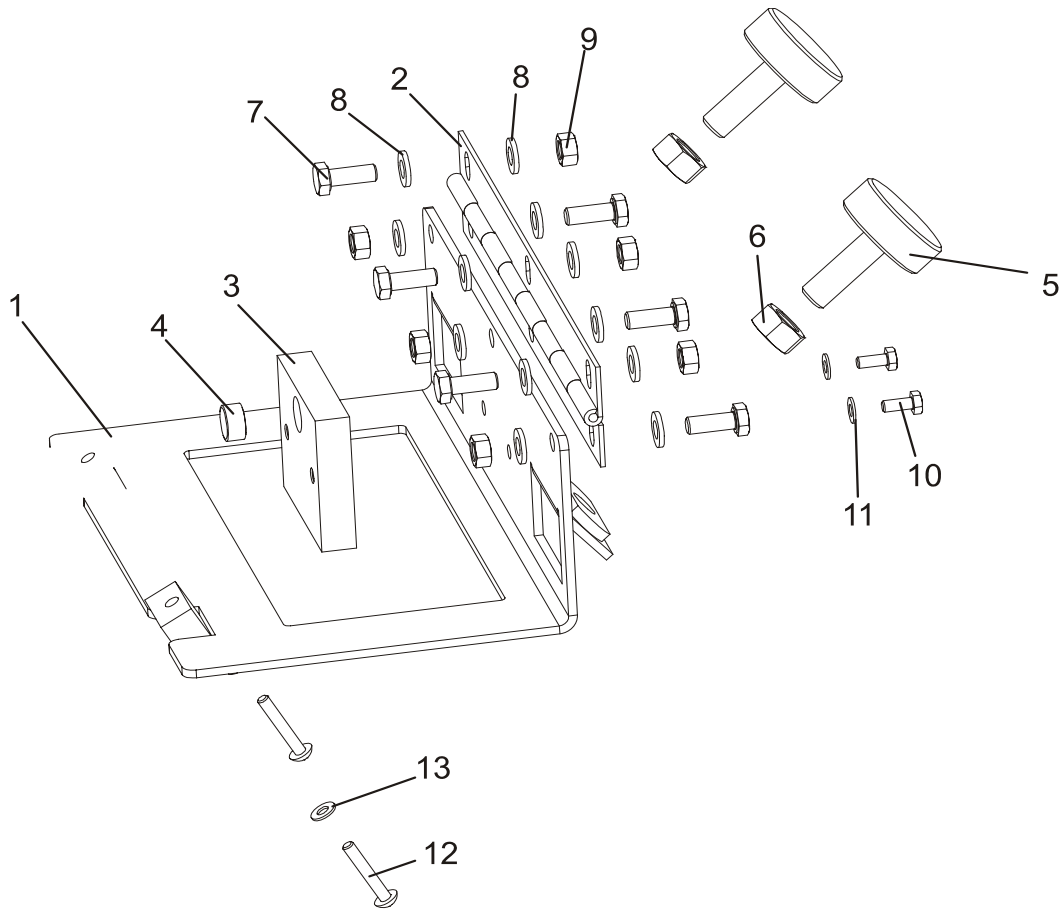

L.P.	DESCRIPTION (◆ Indicates Parts Available In Assemblies Only)	NUMER KAT.	SZT.	
	HOLDER, WIRELESS TRANSMITTER, COMPLETE	100223	1	
1	HOLDER WIRELESS TRANSMITTER, PTD	099187-1	1	
2	HINGE	088257	1	
3	BLOCK, MAGNET MOUNTING	100222	1	
4	MAGNET, ORANGE PAINTED	S10519-1	1	
5	BUMPER M10	092839	2	
6	NUT, M10-8-B-FE	F81033-3	2	
7	BOLT M6X16 8.8 FE/ZN5	F81001-15	6	
8	WASHER, M6, FLAT, ZINC	F81053-1	12	
9	NUT, M6, HEXAGON, FREE, GRADE 5(8.8)ZINC	F81031-1	6	

CONTROL HANGER, AC WIRELESS. (LES)

10	NUT, M10-8-B-FE	F81033-3	2	
11	WASHER 4,3 FE/ZN5	F81051-2	6	

4.7 CONTROL HANGER, AC WIRELESS. (LES)

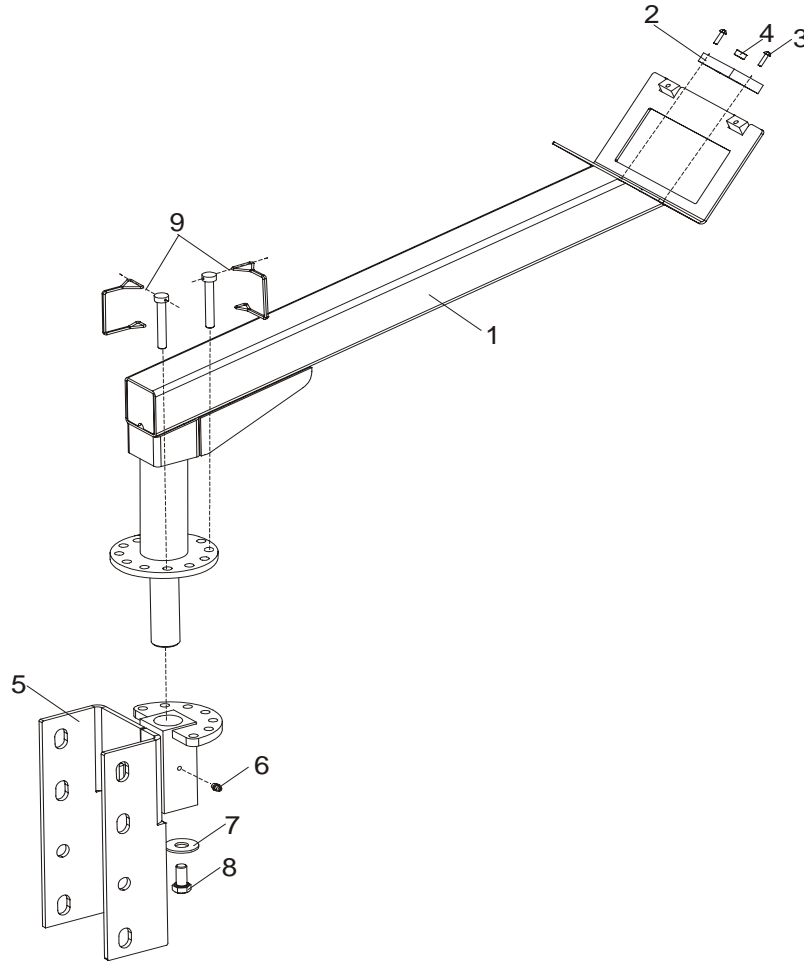

L.P.	DESCRIPTION (◆ Indicates Parts Available In Assemblies Only)	NUMER KAT.	SZT.	
	<b>HANGER, AC WIRELESS CONTROL</b>	501440-1	1	
1	HANGER, CONTROL WLDMT/PTD	100458-1	1	
2	BLOCK, BORAMID-WIRELESS.	100222	1	
3	SCREW, M4X16 5.8-B CROSS RECESSED PAN HE	F81011-42	2	
4	MAGNET, ORANGE PAINTED	S10519-1	1	
5	BRACKET, CONTROL HANGER	100445-1	1	
6	FITTING, M6 GREASE	086280	1	
7	WASHER, 15 SEPCIAL FLAT	F81057-3	1	
8	BOLT, M12X25-8.8 HEX HEAD FULL THREAD ZINC	F81004-31	1	

**4**

**Parts List**

*CONTROL HANGER, AC WIRELESS. (LES)*

---

9	PIN, 3/8X2 1/4 SNAP	014151	2	
---	---------------------	--------	---	--



4.8 CONTROL HANGER, AC WIRELESS (LT40/70)

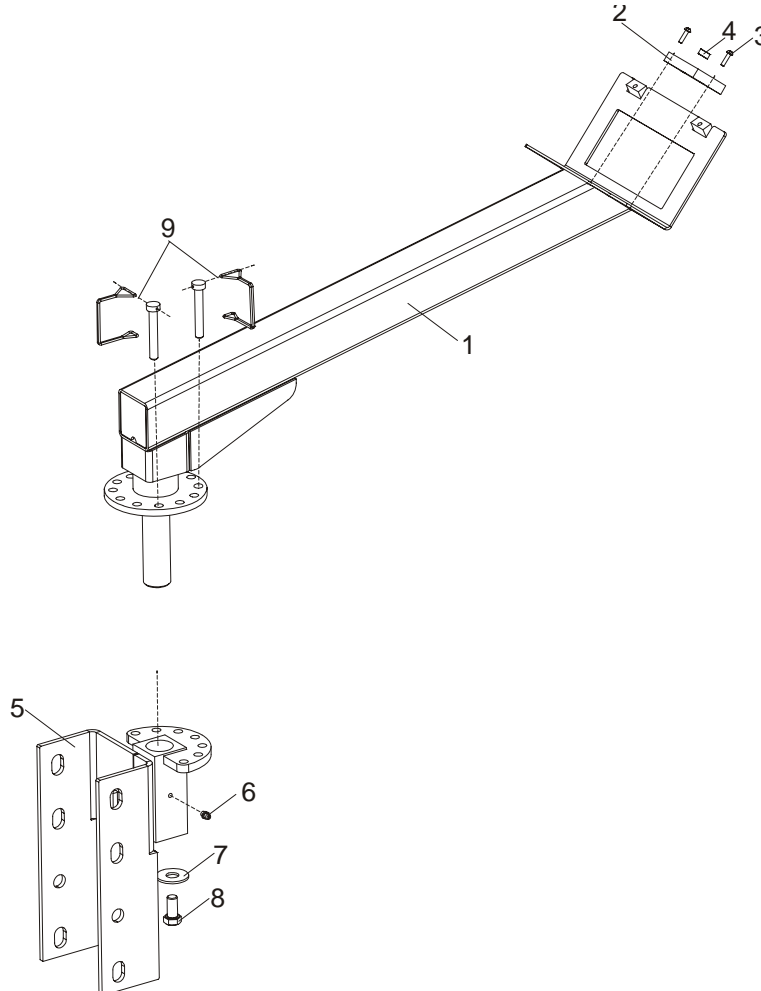

L.P.	DESCRIPTION (◆ Indicates Parts Available in Assemblies Only)	NUMER KAT.	SZT.
	<b>HANGER, AC WIRELESS CONTROL</b>	100451	1
1	HANGER, CONTROL WLDMT/PTD	100458-1	1
2	BLOCK, BORAMID-WIRELESS.	100222	1
3	SCREW, M4X16 5.8-B CROSS RECESSED PAN HE	F81011-42	2
4	MAGNET, ORANGE PAINTED	S10519-1	1
5	BRACKET, CONTROL HANGER	100445-1	1
6	FITTING, M6 GREASE	086280	1
7	WASHER, 15 SEPCIAL FLAT	F81057-3	1
8	BOLT, M12X25-8.8 HEX HEAD FULL THREAD ZINC	F81004-31	1
9	PIN, 3/8X2 1/4 SNAP	014151	2

# 4 Parts List

## WIRELESS KIT, LT20 AC

### 4.9 WIRELESS KIT, LT20 AC

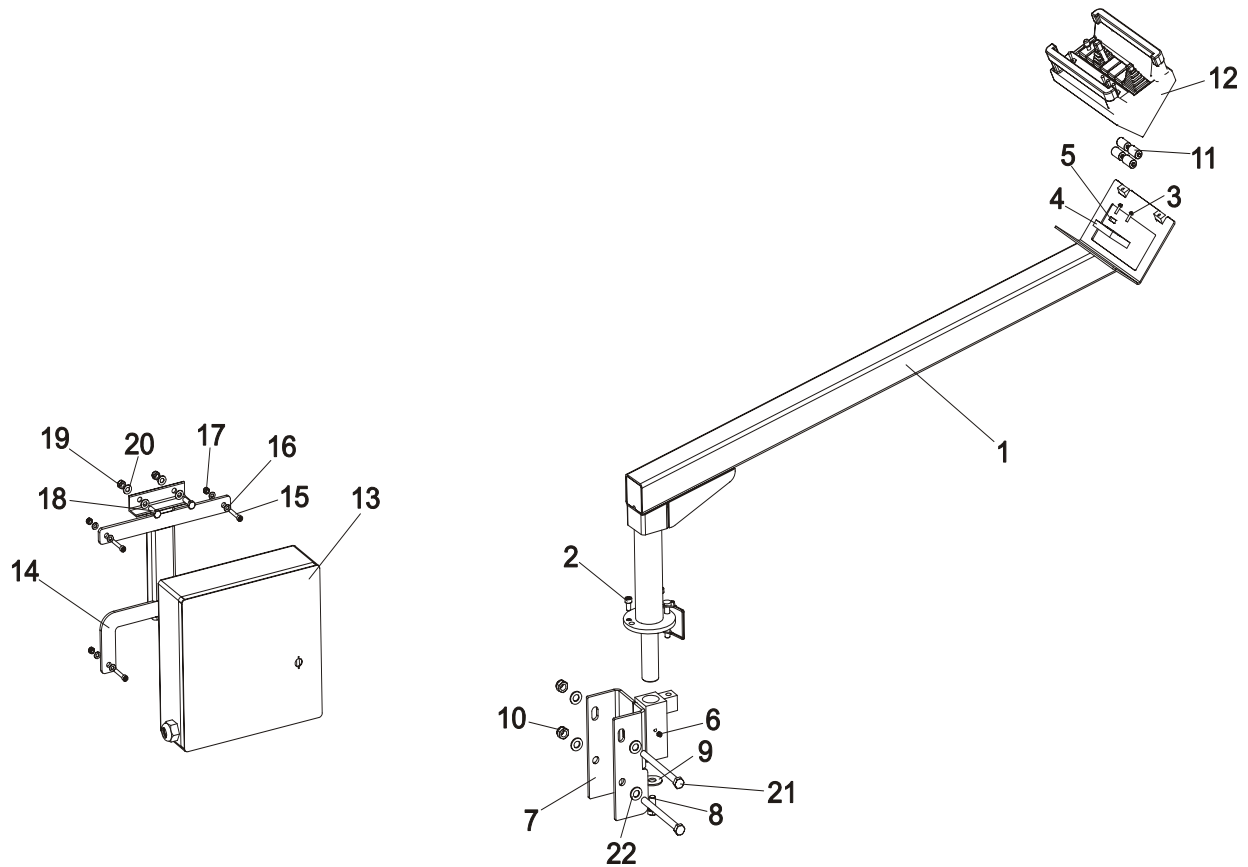

L.P.	DESCRIPTION (◆ Indicates Parts Available in Assemblies Only)	NUMER KAT.	SZT.
	<b>LT20 AC WIRELESS CONTROL SYSTEM</b>	504354	1
	<b>HANGER, LT20 AC WIRELESS CONTROL</b>	100200	1
1	<b>HANGER, AC WIRELESS CONTROL</b>	501440-1	1
2	BOLT M8X16-8.8, SOCKET HEAD	F81002-39	2
3	SCREW M4X16 5,8-B FE/ZN5	F81011-42	2
4	BLOCK, POLYAMIDE - WIRELESS	100222	1
5	MAGNET, ORANGE PAINTED	S10519-1	1
6	FITTING, M6 GREASE	086280	1
7	BRACKET, CONTROL HANGER	501451-1	1
8	BOLT, M12X25-8.8-FE/ZN5	F81004-31	1
9	WASHER, 15 FLAT SPECIAL ZINC-PLATED	F81057-3	1
10	NUT, M12-8, HEX, NYLON, ZINC, LOCK	F81034-2	2
11	BATTERY, R14 ALKALINE	098174	4
12	WIRELESS CONTROL PANEL, AC OMNEX	098917	1
13	INTERFACE OMNEX AC LT20	504353	1

<b>14</b>	BRACKET, WIRELESS JUNCTION BOX WSPORNIK SKRZYNKI ZDALNEGO STEROW. LT20	100710-1	1	
<b>15</b>	BOLT M6X35 -8.8- FE/ZN5, SOCKET HEAD	F81001-23	2	
<b>16</b>	WASHER, M6, FLAT,ZINC	F81053-1	4	
<b>17</b>	NUT,M6-8-B HEX,NYLON LOCK ZINC	F81031-2	2	
<b>18</b>	BOLT,M8X25-8.8-B HEX HEAD FULL THRE	F81002-5	2	
<b>19</b>	NUT,M8-8-B,HEX,NYLON LOCK ZINC	F81032-2	2	
<b>20</b>	WASHER, 8.4 FLAT,ZINC	F81054-1	4	
<b>21</b>	BOLT M12X140-8.8, ZINK	F81004-35	2	
<b>22</b>	WASHER, M12 , FLAT, ZINC	F81056-1	4	