

**INDUSTRIAL PRODUCTS**  
**Safety, Operation, Maintenance**  
**& Parts Manual**

---

**TD2 Transfer Deck** rev. A1.01

---



**Safety is our #1 concern!** Read and understand all safety information and instructions before operating, setting up or maintaining this machine.

*January 2006*

*Form #1191*

# Table of Contents

# Section-Page

<b>SECTION 1</b>	<b>SAFETY</b>	<b>1-1</b>
1.1	Safety Symbols.....	1-1
1.2	Safety Instructions.....	1-2
<b>SECTION 2</b>	<b>GENERAL INFORMATION</b>	<b>2-1</b>
2.1	Transfer Deck Components.....	2-1
2.2	Overall Dimensions.....	2-2
<b>SECTION 3</b>	<b>INSTALLATION &amp; SETUP</b>	<b>3-4</b>
3.1	Air Installation.....	3-4
3.2	Setup.....	3-5
3.3	Pneumatic Box.....	3-7
	<i>Technical Data</i>	
	<i>Connecting The Control Box</i>	
	<i>Maintenance</i>	
	<i>Quickly-Wearing Components</i>	
3.4	Board Stop Adjustment.....	3-9
<b>SECTION 4</b>	<b>OPERATION</b>	<b>4-1</b>
4.1	Control Box Operation.....	4-1
<b>SECTION 5</b>	<b>REPLACEMENT PARTS</b>	<b>5-1</b>
5.1	Table Assembly.....	5-1
5.2	Board Stop/Air Bag Assembly.....	5-3
5.3	Kicker & Air Cylinder.....	5-5
5.4	Pneumatic Box.....	5-6
5.5	Components Outside Pneumatic Box.....	5-8
5.6	Decals, TD2.....	5-9
5.7	Photo Sensor.....	5-10
<b>SECTION 6</b>	<b>ELECTRICAL INFORMATION</b>	<b>6-1</b>
6.1	Electrical Symbol Diagram.....	6-1
6.2	Electrical Component List.....	6-2

## SECTION 1 SAFETY

### 1.1 Safety Symbols

The following symbols and signal words call your attention to instructions concerning your personal safety. Be sure to observe and follow these instructions.



**DANGER!** indicates an imminently hazardous situation which, if not avoided, will result in death or serious injury.



**WARNING!** suggests a potentially hazardous situation which, if not avoided, could result in death or serious injury.



**CAUTION!** refers to potentially hazardous situations which, if not avoided, may result in minor or moderate injury or damage to equipment.



**IMPORTANT!** indicates vital information.

**NOTE:** gives helpful information.



Warning stripes are placed on areas where a single decal would be insufficient. To avoid serious injury, keep out of the path of any equipment marked with warning stripes.

## 1.2 Safety Instructions

**NOTE:** ONLY safety instructions regarding personal injury are listed in this section. Caution statements regarding only equipment damage appear where applicable throughout the manual.

### OBSERVE SAFETY INSTRUCTIONS



**IMPORTANT!** Read the entire Operator's Manual before operating the transfer deck. Take notice of all safety warnings throughout this manual and those posted on the machine. Keep this manual with this machine at all times, regardless of ownership.

Also read any additional manufacturer's manuals and observe any applicable safety instructions including dangers, warnings, and cautions.

Only persons who have read and understood the entire operator's manual should operate the transfer deck. The transfer deck is not intended for use by or around children.

**IMPORTANT!** It is always the owner's responsibility to comply with all applicable federal, state and local laws, rules and regulations regarding the ownership, operation of your AWMV products. All AWMV product owners are encouraged to become thoroughly familiar with these applicable laws and comply with them fully while using the machine.



### KEEP TRANSFER DECK AND AREA AROUND TRANSFER DECK CLEAN



**DANGER!** Maintain a clean and clear path for all necessary movement around the machine and lumber stacking areas. Failure to do so will result in serious injury.

### CAUTIONS FOR TRANSFER DECK SETUP

**WARNING!** Securely fasten the feet of the transfer deck to the floor before operating the machine. Failure to do so may result in serious injury or death.

### CHECK TRANSFER DECK BEFORE OPERATION



**DANGER!** Make sure all guards and covers are in place and secured before operating the transfer deck. Failure to do so may result in serious injury.



### KEEP PERSONS AWAY



**WARNING!** Keep all persons out of the path of moving equipment and boards while operating transfer deck. Failure to do so may result in serious injury or death.

**USE PROPER PROCEDURE WHEN CONDUCTING MAINTENANCE**



**DANGER!** Make sure all electrical installation, service and/or maintenance work is performed by a qualified electrician and is in accordance with applicable electrical codes.

**DANGER!** Hazardous voltage inside the control box and at the motor can cause shock, burns, or death. Disconnect and lock out power supply before servicing! Keep all electrical component covers closed and securely fastened during operation.





**WARNING!** Consider all electrical circuits energized and dangerous.

**WARNING!** Never assume or take the word of another person that the power is off; check it out and lock it out.

**WARNING!** Do not wear rings, watches, or other jewelry while working around an open electrical circuit.



**KEEP SAFETY LABELS IN GOOD CONDITION**

 **IMPORTANT!** Always be sure that all safety decals are clean and readable. Replace all damaged safety decals to prevent personal injury or damage to the equipment. Contact your local distributor, or call your Customer Service Representative to order more decals.

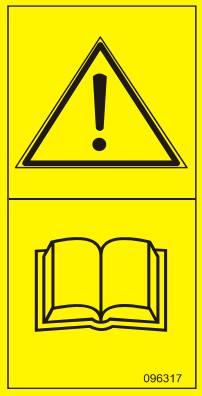

 **IMPORTANT!** If replacing a component which has a safety decal affixed to it, make sure the new component also has the safety decal affixed.

**See Table 1-1.** Pictogram decals used to warn and inform the user about danger.

**TABLE 1-1**

Decal View	W-M No.	Description
	096317	CAUTION! Read thoroughly the manual before operating the machine. Observe all safety instructions and rules when operating the sawmill.
	099221	CAUTION! Gear danger – keep a safe distance away!

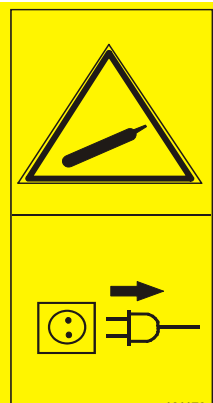
**TABLE 1-1**

	<p>099780</p>	<p>Caution! Slabs falling off the deck!</p>
	<p>101176</p>	<p>CAUTION! High air pressure in the installation even after disconnecting the power.</p>
	<p>P85070</p>	<p>CE safety certification</p>



## SECTION 2 GENERAL INFORMATION

### 2.1 Transfer Deck Components

The Transfer Deck (TD2) enables you to change the direction of material flow. The transfer deck is also equipped with the kicker system allowing you to separate boards and cants. The following instructions will guide you in installation, operation, and alignment of the Transfer Deck.

 **WARNING!** Keep all persons out of the path of moving equipment and boards while operating transfer deck. Failure to do so may result in serious injury or death.

See Figure 2-1. The main components of the Transfer Deck are shown below.

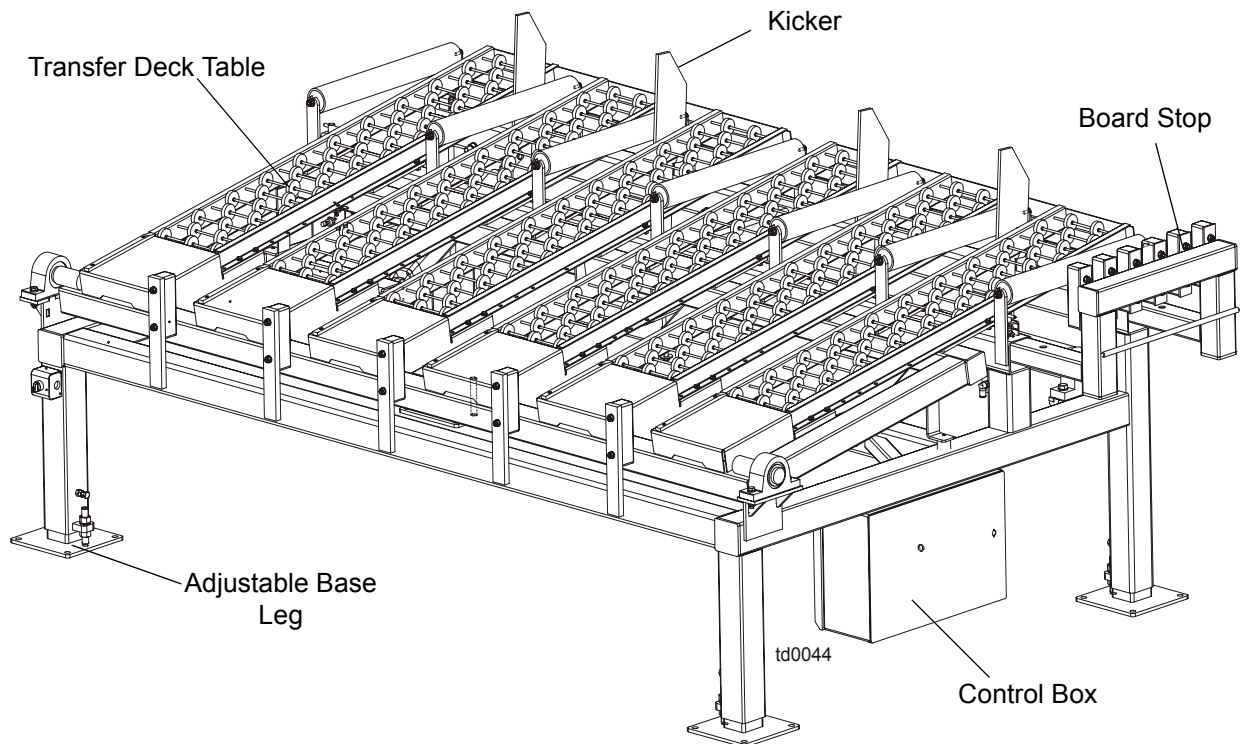

**FIG. 2-1 TRANSFER DECK (TD2)**

## 2.2 Overall Dimensions

See Figure 2-2. The overall dimensions of the Transfer Deck (TD2) are shown below.

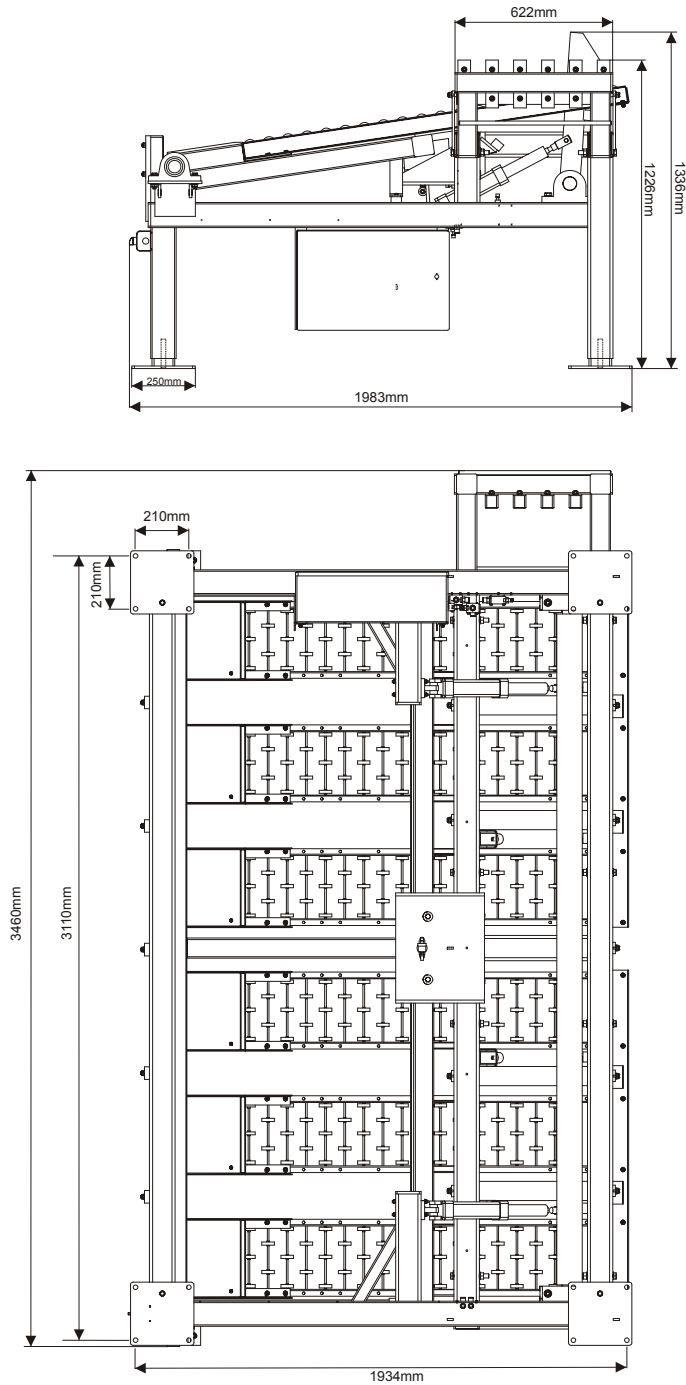

**FIG. 2-2 TRANSFER DECK (TD2)**

See Figure 2-3. Weight are listed below.

Model	Weight
TD2	730 kg

## SECTION 3 INSTALLATION & SETUP

### 3.1 Air Installation

See Figure 3-1. The transfer deck air system diagram is shown below.

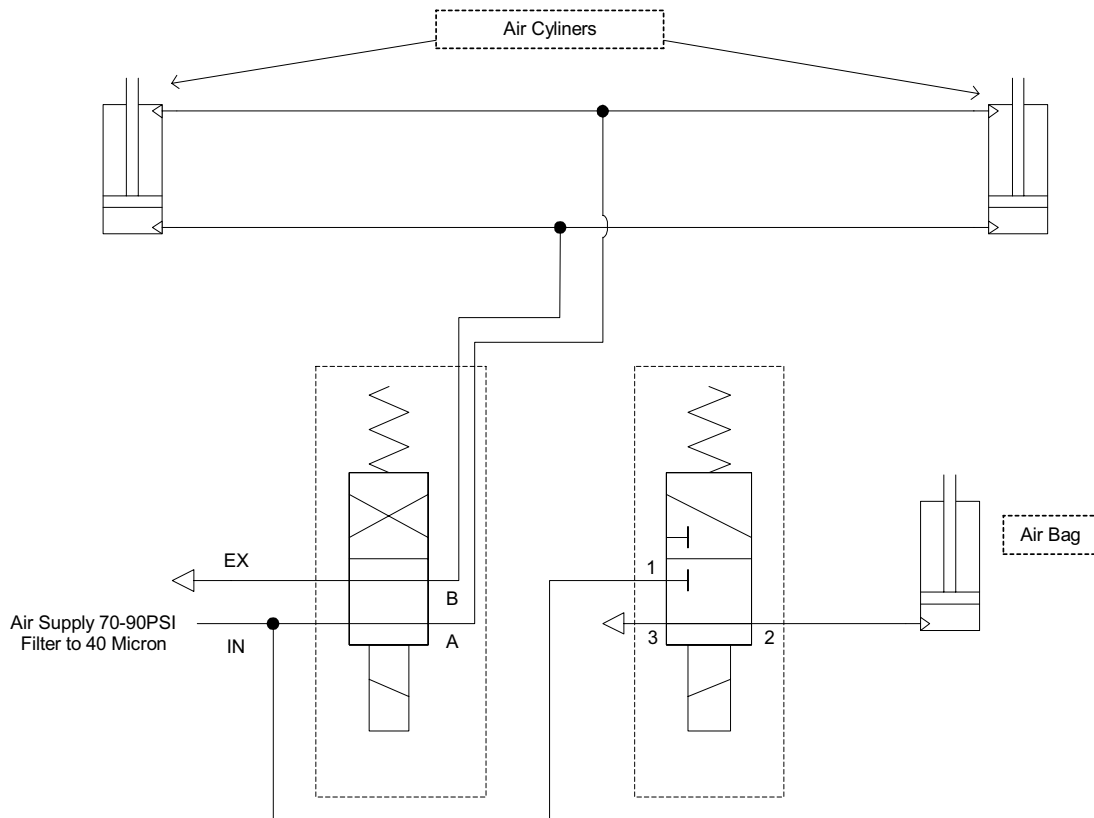

**FIG. 3-1**

**NOTE:** AWMV highly recommends using the Transfer Deck together with the AWMV Incline Conveyor. After connecting the transfer deck table to the air supply, the transfer deck table automatically lowers when the board or cant gets between the electronic sensors on the incline conveyor belt. The transfer deck table automatically raises when the board or cant leaves the incline conveyor and there is no object on the incline conveyor belt between the electronic sensors.

To operate the transfer deck with the incline conveyor, connect the transfer deck air supply line labeled IN to the air supply. **NOTE:** Make sure each hose fits tight on the fitting before operating the unit.

### 3.2 Setup

Prepare a firm, level area where the transfer deck can be anchored before operating the unit. A cement pad with 1/2" diameter anchor bolts is recommended.



**WARNING!** Securely fasten the feet of the transfer deck to the floor before operating the unit. Failure to do so may result in serious injury or death.

**NOTE:** If you use the AWMV Incline Conveyor, the distance between the transfer deck and conveyor should be approximately 635 mm.

See Figure 3-2.

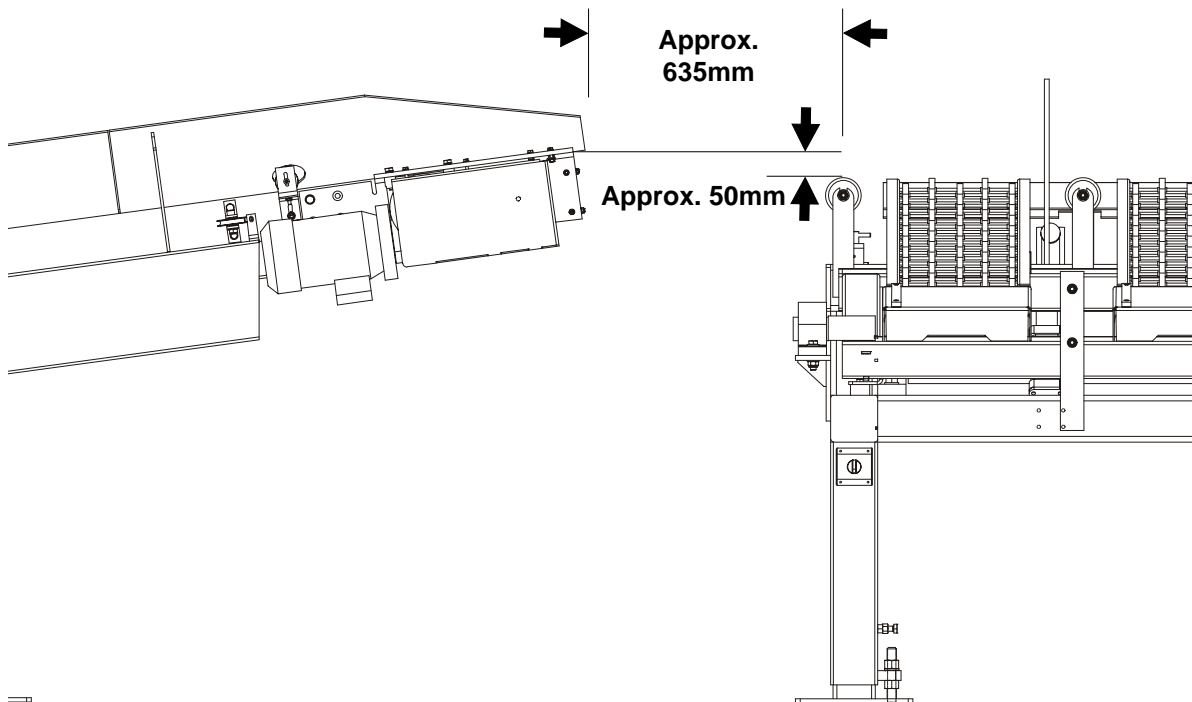

**FIG. 3-2 TRANSFER DECK (TD2)**

The top of the conveyor drive roller should be approximately 50mm higher than the top of the transfer deck rollers. Make sure that lumber can easily get to the transfer deck table.

## **3** Installation & Setup

### *Setup*

---

Adjust the legs so each leg is in contact with the ground. Loosen the locking bolt. Turn the adjustment bolt clockwise to raise, turn counterclockwise to lower the transfer deck frame.

See Figure 3-3.

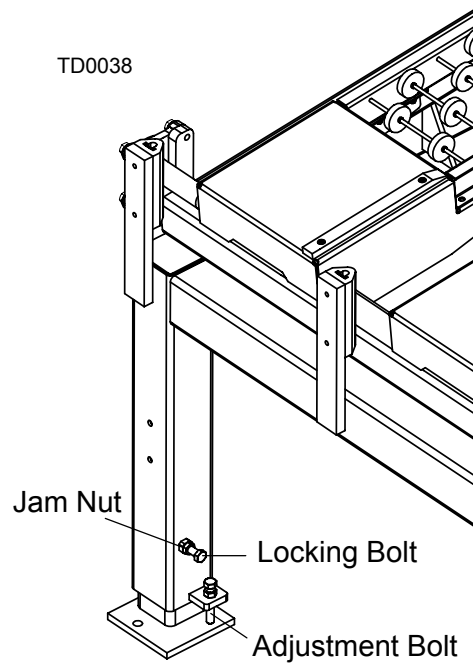

**FIG. 3-3 TRANSFER DECK (TD2)**

Secure the leg with the locking bolt. Tighten the jam nuts when the adjustment is complete.

### 3.3 Pneumatic Box

#### *Technical Data*

See Table 3-1.

<b>Duty Cycle</b>	Continuous operation
<b>Weight</b>	17 kg
<b>Working Medium</b>	Compressed air
<b>Maximum Pressure</b>	0,9 MPa
<b>Working Pressure</b>	0,6 MPa
<b>Filter Porosity</b>	40 $\mu$ m
<b>Temperature</b>	0°C do +50°C
<b>Supply Voltage For Solenoid Valves</b>	24 V DC +/- 10%

**TABLE 3-1**

#### *Connecting The Control Box*

When delivered, the control box is completely assembled and tested for air tightness and electrical connection.

Perform the following steps to get the control box ready for work:

- connect compressed air to the ball valve,
- connect the control box to the pneumatic system,
- connect the control system to the terminal block,
- open the ball valve and set the working pressure to 0.6 MPa,
- fill the lubricator with oil (insert the end of the lubricator hose into a container with oil, push the red button, fill the lubricator up to the line marked on it and release the red button).

#### *Maintenance*

Follow the following instructions to ensure proper control box functioning:

- Check the lubricator oli level every month. Add oil as necessary.
- Always check the working pressure after connecting the control box. If necessary, adjust it with the knob on the filter regulator.

- Every month make sure the filter cartridge is clean. Replace the cartridge if it is very dirty.

#### ***Quickly-Wearing Components***

- Filter Cartridge



### 3.4 Board Stop Adjustment

The Board Stop Assembly can be mounted to either of the Transfer Deck sides. Install the board stop on the side opposite to the direction from which the lumber is flowing. The boards will stop as soon as they hit the board stop assembly.

 **WARNING!** Keep all persons out of the moving equipment and boards while operating transfer deck. Failure to do so may result in serious injury or death.

Adjust the accessory roller width to suit your application. To adjust the board stop:

1. Lift and turn the two pins securing the board stop in its closest-to-table position.
2. Move the board stop assembly so that it is long enough to make the lumber fit the transfer deck table. The maximum board dimension to be used with the transfer deck can not exceed 16 ft. (4.88m).

See Figure 3-4.

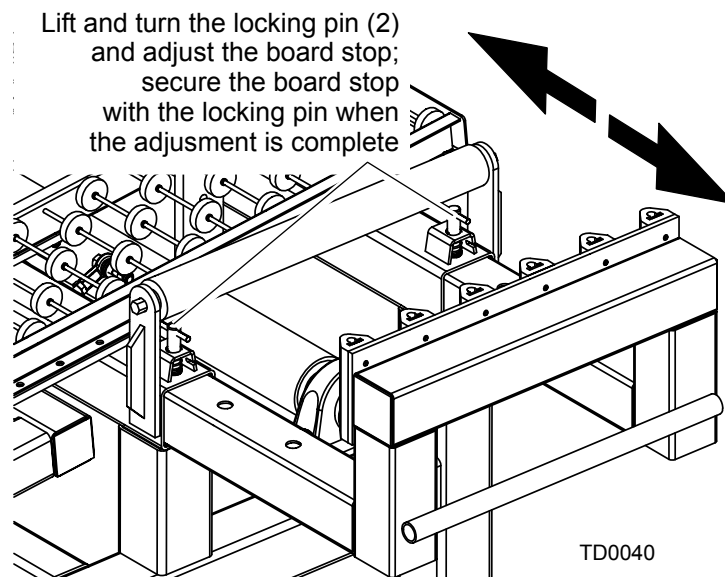

**FIG. 3-4 TRANSFER DECK (TD2)**

3. Secure the board stop assembly with the two locking pins when the adjustment is complete.

## SECTION 4 OPERATION

### 4.1 Control Box Operation

The transfer deck is provided with all the necessary air hoses connected. To operate the transfer deck, make the appropriate connections. [See Section 3.1 Air Installation](#), for transfer deck air system diagram.

The transfer deck is designed to work with the incline conveyor. This manual explains how to operate the unit working together with the incline conveyor.

Use the table switch located on the table leg to operate the transfer deck option. Turn the table switch to the "AUTO" position to make the table lower when the lumber comes from the incline conveyor. The table raises automatically when the lumber gets on the table and leave the conveyor. The lumber slides down when the table raises.

See Figure 4-1.

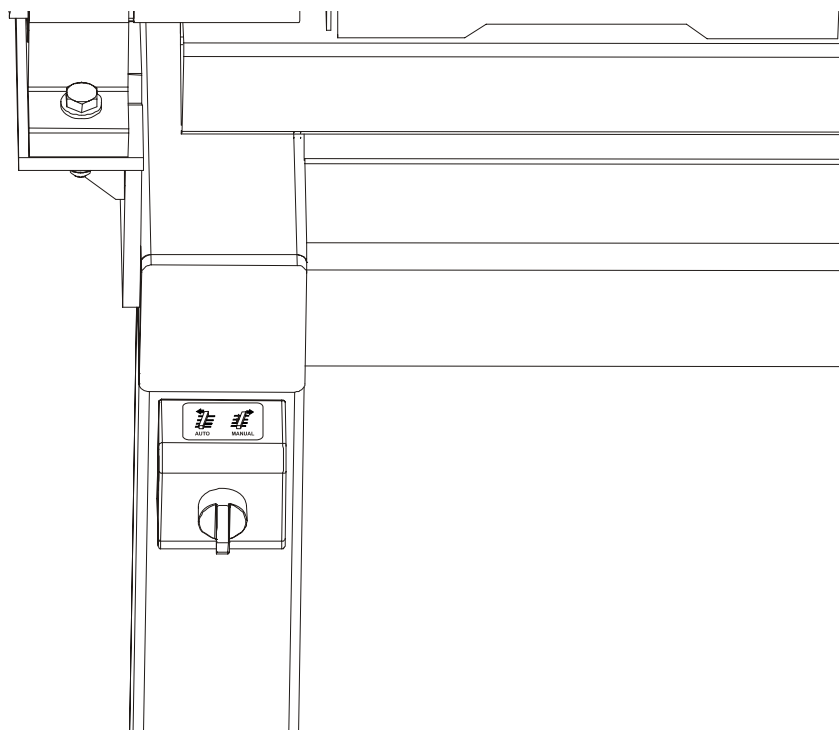

**FIG. 4-1 TRANSFER DECK**

Turn the table switch to the middle position to lower the transfer deck table. Use the middle position to keep the table down when operating the kicker.

### ***Operating the kicker***

The transfer deck kicker is designed to help the operator separate different kind of lumber, e.g. cants and boards. Use the kicker whenever it is necessary to save your time and for convenience.

To separate cants from boards, turn the table switch to the middle position to prevent the cants from sliding down the table. Turn the table switch to "MANUAL" position to raise the kicker. The kicker pulls the cant off the table. Release the table switch to lower the kicker. **NOTE:** Have a cart or other collection system available next to the transfer deck to receive the cants as they are kicked off the table.

## SECTION 5 REPLACEMENT PARTS

### 5.1 Table Assembly

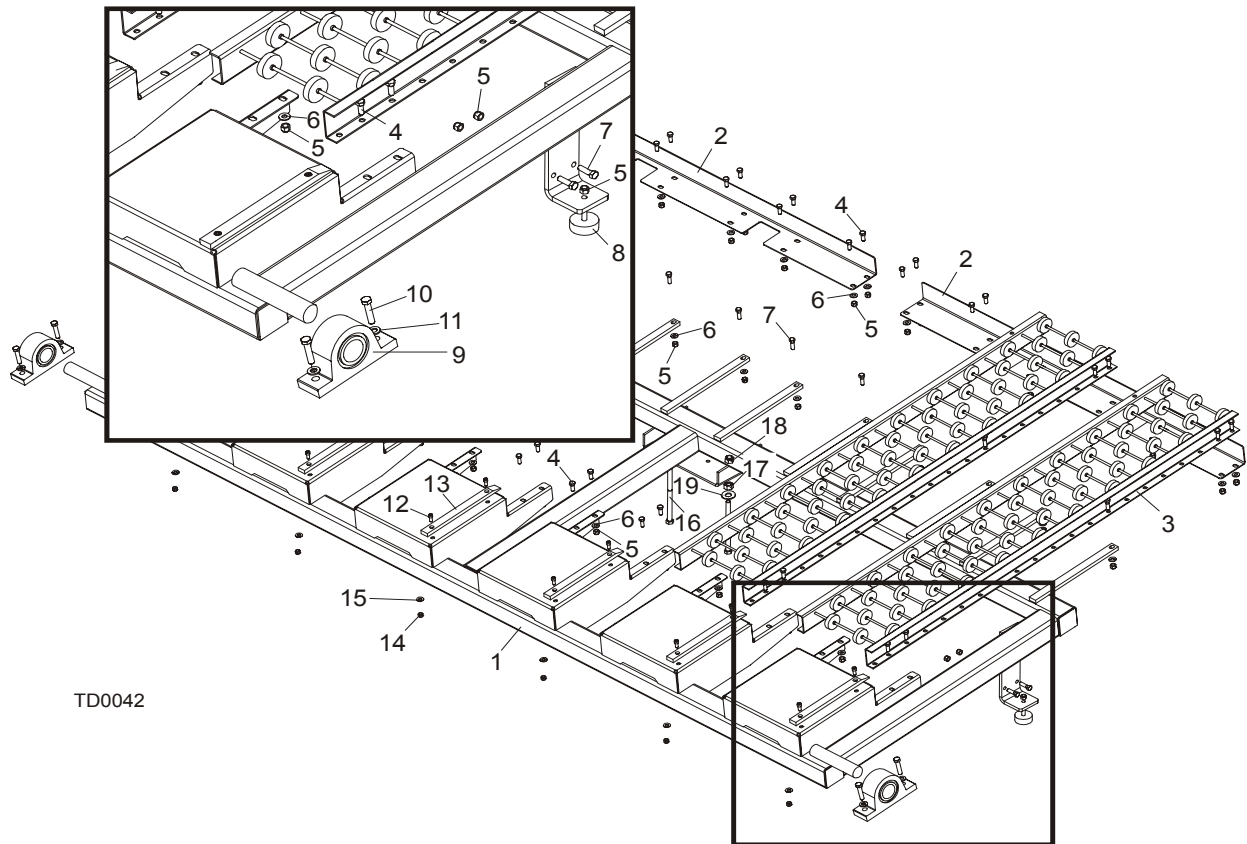

TD0042

REF	DESCRIPTION (◆ Indicates Parts Available In Assemblies Only)	PART #	QTY.
1	FRAME WELDMENT, TD2 TABLE	095425-1	1
2	ANGLE, ROLLER SKATE	095435-1	2
3	CONVEYOR, ROLLER 5' MODIFIED	036418	6
4	BOLT, M8x20-5.8 HEX HEAD	F81002-1	48
5	NUT, M8-8-B HEX NYLON LOCK	F81032-1	48
6	WASHER, 8,4 FLAT	F81054-1	48
7	BOLT, M8x25-8.8-B HEX HEAD GRADE 5	F81002-5	12
8	BUMPER, TABLE	089729	2
9	BEARING ASSEMBLY, UCP 210 CX	089041	2
10	BOLT, M12x55-8.8	F81004-12	4
11	WASHER, 13, FLAT	F81056-1	4
12	SCREW, M6x16, HEX SOCKET HEAD CAP	F81001-21	12
13	BAR, TD2 BOARD SLOW DOWN	094385	6
14	NUT, M6-8-B NYLON HEX	F81031-2	12

15	WASHER, 6,4, FLAT	F81053-1	12	
16	BOLT, M12x170-8.8 HEX HEAD	F81004-7	2	
17	NUT, M12-8-B	F81034-1	2	
18	NUT, HEX NYLON LOCK	F81034-2	2	
19	WASHER, 15 FLAT SPECIAL ZINC-PLATED	F81057-3	2	

# 5 Replacement Parts

## Board Stop/Air Bag Assembly

### 5.2 Board Stop/Air Bag Assembly

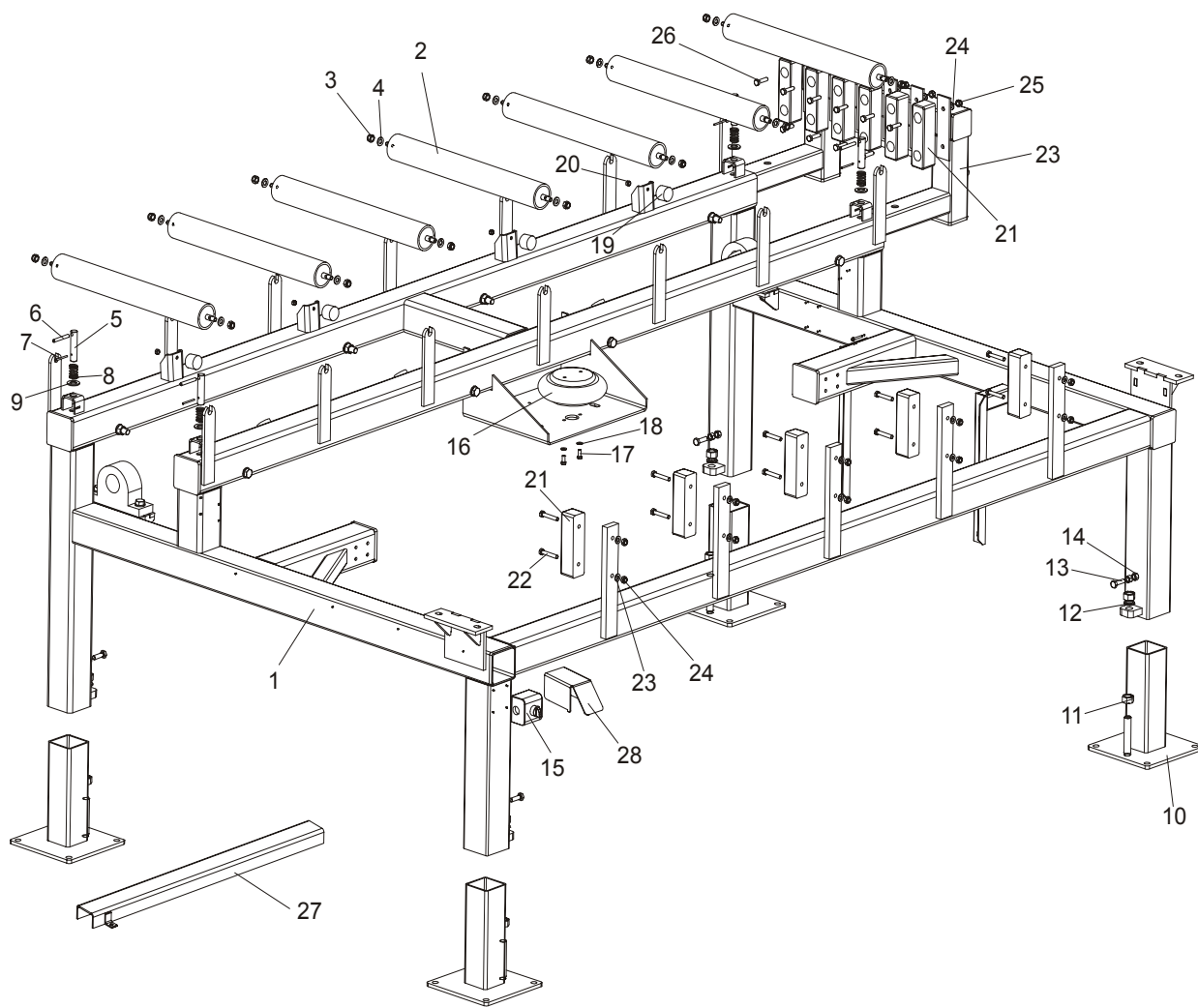

REF	DESCRIPTION (◆ Indicates Parts Available In Assemblies Only)	PART #	QTY.
1	FRAME WELDMENT, TD2 PAINTED	095425-1 <sup>1</sup>	1
2	ROLLER, 76 DIA. L=605 L1=678 M12 EXT. THREAD 3.2 THICK	095160	7
3	NUT, M12-8 HEX NYLON ZINC LOCK	F81034-2	14
4	WASHER, 13 FLAT ZINC	F81056-1	14
5	PIN, OUTRIGGER PULL ZINC-PLATED	087012-1	4
6	PIN, 8 X 65 SPRING-TYPE STRAIGHT ZINC	F81046-1	4
7	PIN, 4 X 50 SPRING-TYPE STRAIGHT ZINC	F81044-6	4
8	SPRING, 21DIA. X 38 X 2 ZINC-PLATED	087040	4
9	WASHER, 21 FLAT ZINC	F81059-2	4
10	LEG WELDMENT, PAINTED BASE	089766-1 <sup>1</sup>	4

11	NUT, M20-8 HEX ZINC	F81037-1	8	
12	WASHER, 20.5 SPLIT LOCK ZINC	F81059-1	4	
13	BOLT, M12 X 40-8.8 HEX HEAD FULL THREAD ZINC	F81004-4	4	
14	NUT, M12-8-B HEX ZINC	F81034-1	8	
15	BLOCK, TD1/TD2 KICKER SWITCH	095006	1	
16	BAG, 192 308 1000 (REXROTH) AIR	088576	1	
17	BOLT, M8 X 20-5.8 HEX HEAD FULL THREAD ZINC	F81002-1	2	
18	WASHER, 8.4 FLAT ZINC	F81054-1	2	
	BUMPER ASSEMBLY, #117C	089729	4	
19	BUMPER, RUBBER	089728	1	
20	NUT, M8-8-B HEX ZINC	F81032-1	1	
21	STOP, #054B BOARD RUBBER	089717	11	
22	BOLT, M10 X 60-8.8 HEX HEAD ZINC	F81003-10	10	
23	STOP WELDMENT, BOARD	089746-1 <sup>1</sup>	1	
24	WASHER, 10.5 FLAT ZINC	F81055-1	22	
25	NUT, M10-8-B HEX NYLON ZINC LOCK	F81033-1	22	
26	BOLT, M10x40-8.8 HEX HEAD FULL THREAD ZINC	F81003-16	12	
27	HOSES COVER	097280-1	1	
28	COVER, CONTROL SWITCH, TD2	507599-1	1	

<sup>1</sup> The part can be painted orange or green, depending on the color of the sawmill the transfer deck is used with (LT70 AC Remote - orange or LT300 - green). If it is orange-painted, its Wood-Mizer number ends in -70. If it is green-painted, the number ends in -300.

# 5 Replacement Parts

## Kicker & Air Cylinder

### 5.3 Kicker & Air Cylinder

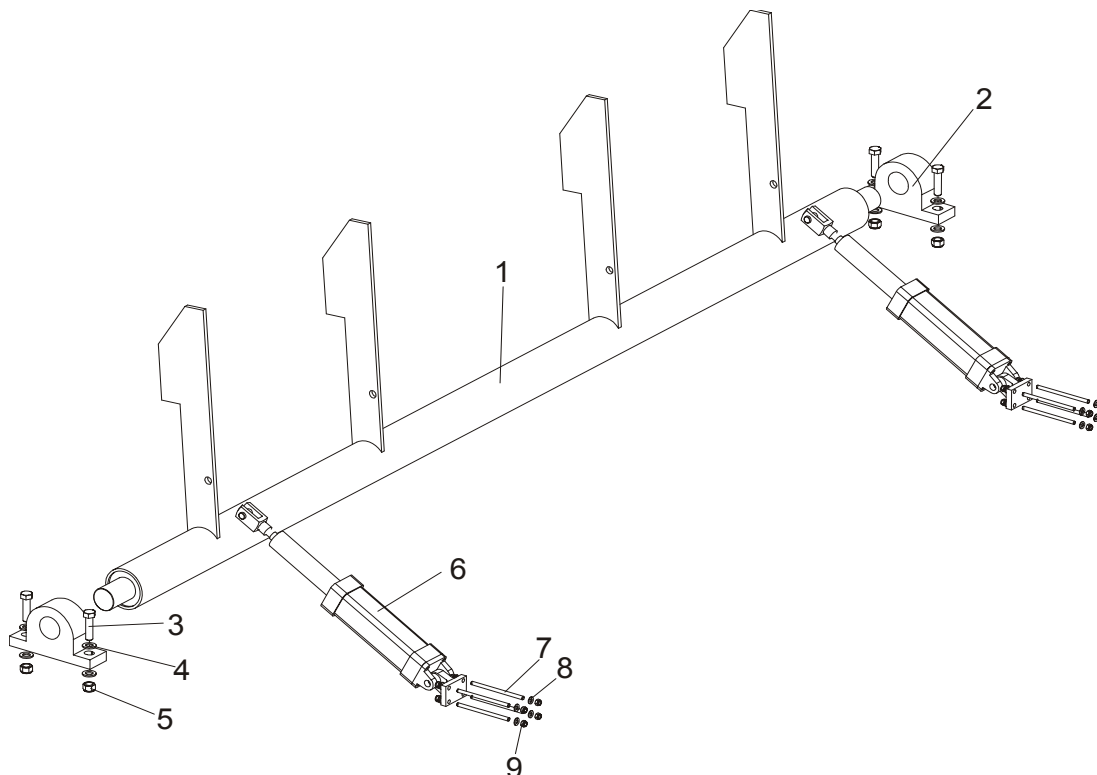

REF	DESCRIPTION (◆ Indicates Parts Available In Assemblies Only)	PART #	QTY.	
1	TUBE WELDMENT, TD2 KICKER PAINTED	095434-1	1	
2	BEARING, UCP211 CX PILLOW BLOCK	089738	1	
3	BOLT, M16x60 8.8 HEX HEAD FULL THREAD ZINC	F81006-12	4	
4	WASHER, 17 FLAT ZINC	F81058-1	8	
5	NUT, M16-8 HEX NYLON ZINC LOCK	F81036-2	4	
6		095446	2	
7	ROD, TD2 AIR CYLINDER THREADED	095447	8	
8	WASHER, 8.4 FLAT ZINC	F81054-1	16	
9	NUT, M8-8-B HEX NYLON ZINC LOCK	F81032-2	16	



## 5.4 Pneumatic Box

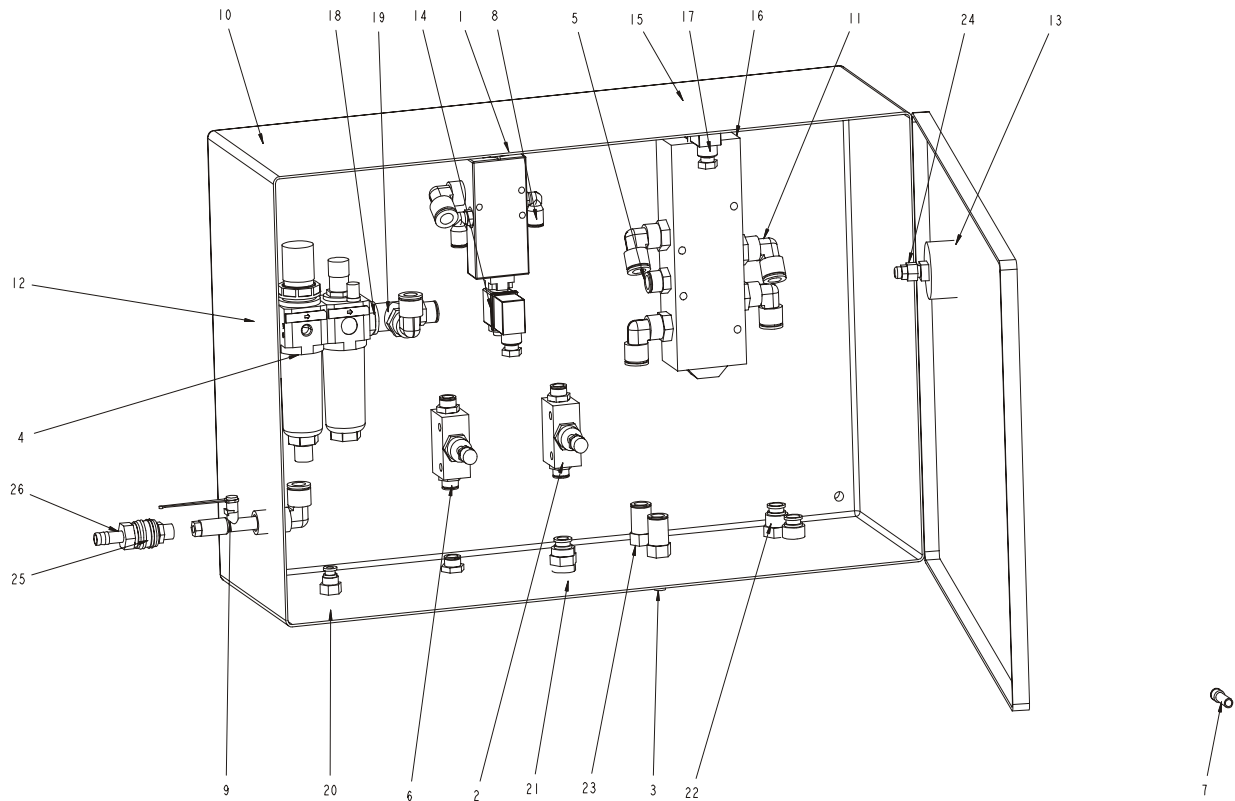

REF	DESCRIPTION (◆ Indicates Parts Available In Assemblies Only)	PART #	QTY.
	BOX, TD2 PNEUMATIC	092404	
1	VALVE, 3/2 1/4" THREAD 24VDC SOLENOID	090223	1
2	VALVE, 1/4" THREAD FLOW CONTROL	090227	2
3	SILENCER, 1/2"	090229	2
4	FILTER PRESSURE REGULATOR & LUBRICATOR - 1/2" THREAD	090231	1
5	FITTING, 1/2" THREAD 12MM HOSE STRAIGHT MALE	090232	2
6	FITTING, 1/4" THREAD 10MM HOSE STRAIGHT	090233	5
7	FITTING, REDUCER	090236	1
8	FITTING, R1/4" 10 HOSE ELBOW	090782	2
9	VALVE, 1/2" INT. THREAD BALL	090933	1
10	BOX WELDMENT, PNEUMATIC	091532	1
11	FITTING, 1/2" THREAD - 12 MM ELBOW MALE	094375	7
12	FITTING, R1/4" - 12 HOSE ELBOW	094398	1
13	GAUGE, 50MM DIA. 0-12 BAR PRESSURE	096281	1
14	CONNECTOR, ELECTRICAL	096282	1
15	COIL, 24VDC	096283	2
16	VALVE, 5/2 1/2" THREAD 24VDC SOLENOID	096284	1

**5****Replacement Parts***Pneumatic Box*

---

17	CONNECTOR, ELECTRICAL	096285	1	
18	NIPPLE, 1/2" THREAD	096286	1	
19	CONNECTOR, 1/2" EXT. THREAD + 2x1/2" INT. THREAD TEE	096287	1	
20	FITTING, Mx14 6 HOSE BULKHEAD	096288	1	
21	FITTING, M22x1 10 HOSE BULKHEAD	096289	1	
22	FITTING, M22x1 12 HOSE BULKHEAD	096290	2	
23	FITTING, 1/2" INT. THREAD 12 HOSE STRAIGHT	096291	2	
24	FITTING, 1/8" INT. THREAD 6MM HOSE PRESSURE GAUGE	096293	1	
25	CONNECTOR, 26 TYPE 1/2" THREAD	096295	1	
26	FITTING, 26 TYPE 1/2" THREAD QUICK DISCONNECT	096296	1	

## 5.5 Components Outside Pneumatic Box

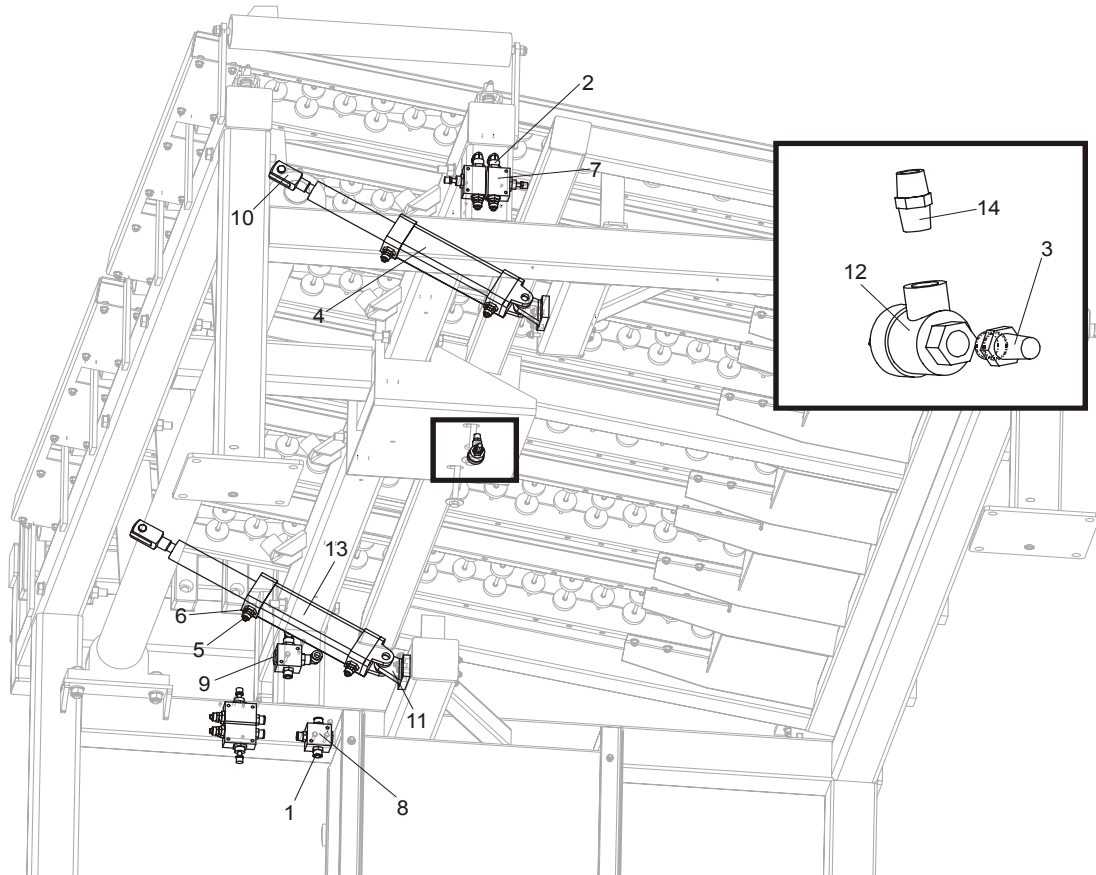

REF	DESCRIPTION (◆ Indicates Parts Available In Assemblies Only)	PART #	QTY.
	<b>TD2 PNEUMATIC COMPONENTS OUTSIDE BOX</b>	092405	
1	FITTING, 1/2" THREAD 12MM HOSE STRAIGHT MALE	090232	6
2	FITTING, 1/2" THREAD - 12 MM ELBOW MALE	094375	4
3	SILENCER, 1/4"	094411	1
4	CYLINDER, 125/160 PUSH/PULL AIR	095446	2
5	FITTING, 3/8 EXT. THREAD 9x12MM STRAIGHT	096297	8
6	FITTING, 3/8 INT. THREAD - 1/2 EXT. THREAD SHORT REDUCER	096298	8
7	VALVE, 1/2" THREAD FLOW CONTROL	096299	4
8	BLOCK, 4 x 1/2" THREAD	096301	2
9	CAP, 1/2" THREAD	096302	2
10	FORK, D125 W/CLIPS	096303	2
11	TRUNNION W/SUPPORT BRACKET	096304	2
12	VALVE, 1/4" THREAD QUICK EXHAUST	096305	1
13	NIPPLE, 1/4" THREAD	096306	1
14	NIPPLE, 1/4" THREAD - 1/4" THREAD TAPER	096307	1

# 5 Replacement Parts

## Decals, TD2

### 5.6 Decals, TD2

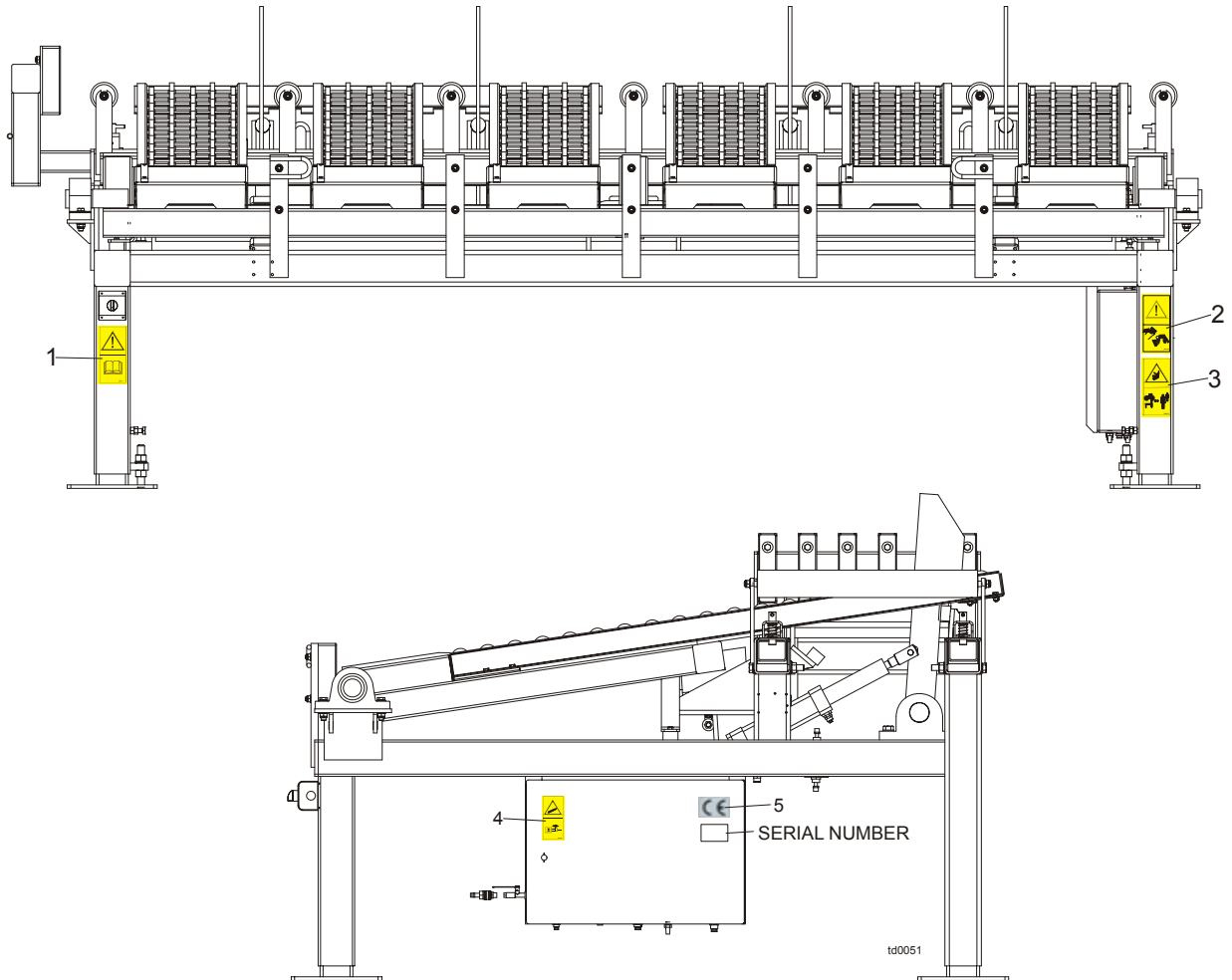

REF	DESCRIPTION (◆ Indicates Parts Available In Assemblies Only)	PART #	QTY.
	<b>DECALS KIT, TD2 PICTOGRAMS</b>	<b>503614</b>	<b>1</b>
1	Decal, read operator's manual (pictogram)	<b>096317</b>	<b>1</b>
2	Decal, look out for the falling slabs (pictogram)	<b>099780</b>	<b>1</b>
3	Decal, keep away warning (pictogram)	<b>099221</b>	<b>1</b>
4	Decal, high air pressure in the installation even after disconnecting the power	<b>101176</b>	<b>1</b>
5	Decal, CE - Certified Sawmill	<b>P85070</b>	<b>1</b>

## 5.7 Photo Sensor

[See Section 5.2](#) in the Incline Conveyor Manual (Form #1121).

## SECTION 6 ELECTRICAL INFORMATION

### 6.1 Electrical Symbol Diagram

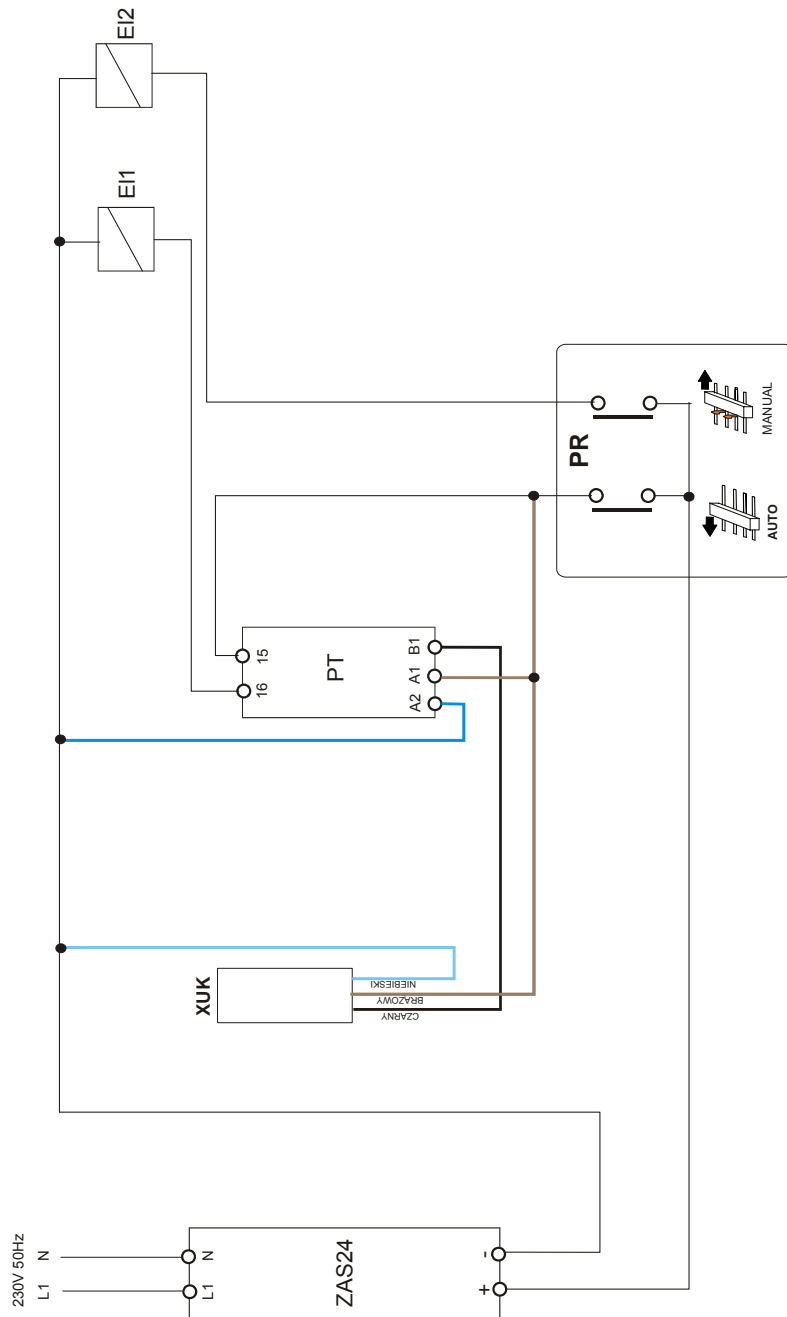

**FIG. 6-1**

## 6.2 Electrical Component List

Component	Wood-Mizer Part No.	Description
ZAS24	500452	Power Supply, 24V MDR-40-24 1,7A
XUK	093169	Sensor, Photo Transmitter
PT	501015	Relay, FINDER 80.01.0.240.0000 Time
PR		Switch, Operation Mode
EI1		Valve, Air Bag Solenoid
EI2		Solenoid Valve, Air Cylinders

**TABELA 6-1**

## EC declaration of conformity according to EC Machinery Directive 2006/42/EC

We herewith declare,

Wood-Mizer Industries sp. Z O.O.  
114 Nagorna street, 62-600 Kolo; Poland.

That the following described machine in our delivered version complies with the appropriate basic safety and health requirements of the EC Machinery Directive 2006/42/EC based on its design and type, as brought into circulation by us. In case of alteration of the machine, not agreed by us, this declaration is no longer valid.

Designation of the machine:

**Transfer Deck**

TYPE:

TD2

No. of manufacturer:

.....

Applicable EC Directives:

EC Machinery Directive 2006/42/EC  
EC Low-Voltage Directive 2006/95/EC  
EC Electromagnetic Compatibility Directive  
2004/108/EC

Responsible for Technical Documentation:

Roman Frontczak / R&D Director

Date/Authorized Signature:

29. 12. 2009



Title :

R&D Director



# INDEX

---

## E

electrical information 6-1  
symbol diagram (460V) 6-1

---

## G

general information  
components 2-1  
dimensions 2-2

---

## I

informacje dotycz¹ce uk³adu elektrycznego  
czêœci sk³adowe traków LT30/40 6-2

installation  
air installation 3-4, 3-5, 3-9  
board stop adjustment 3-9  
setup 3-5

---

## O

operation  
control box 4-1

---

## R

replacement parts 5-1  
board stop 5-3  
control box 5-6  
kicker & air cylinder 5-5  
photo sensors 5-10  
table 5-1