

INDUSTRIAL PRODUCTS

# Incline Conveyor

Safety, Setup, Operation  
& Maintenance Manual

---

IC1, IC2, IC3 & IC4 rev. A2.01

---



**Safety is our #1 concern!** Read and understand all safety information and instructions before operating, setting up or maintaining this machine.

*June 2001*

*Form #1121*

# Table of Contents

# Section-Page

<b>SECTION 1</b>	<b>SAFETY</b>	<b>1-1</b>
1.1	Safety Symbols.....	1-1
1.2	Safety Instructions.....	1-1
	<i>Safety Labels Description</i>	
<b>SECTION 2</b>	<b>GENERAL INFORMATION</b>	<b>2-1</b>
2.1	Installation and Setup.....	2-1
2.2	Overall Dimensions.....	2-3
<b>SECTION 3</b>	<b>OPERATION &amp; SETUP</b>	<b>3-1</b>
3.1	Operation.....	3-1
<b>SECTION 4</b>	<b>MAINTENANCE</b>	<b>4-1</b>
4.1	Gearbox Oil.....	4-1
4.2	Belt Alignment.....	4-1
4.3	Drive Chain Adjustment.....	4-1
<b>SECTION 5</b>	<b>REPLACEMENT PARTS</b>	<b>5-1</b>
5.1	Idle Side Pulley & Rollers.....	5-1
5.2	Motor & Drive Roller.....	5-1
5.3	Legs.....	5-1
5.4	Decals.....	5-1
<b>SECTION 6</b>	<b>ELECTRICAL INFORMATION</b>	<b>6-1</b>
6.1	Electrical Symbol Diagram IC-70.....	6-1
6.2	Electrical Symbol Diagram IC-300.....	6-2

# Table of Contents

# Section-Page

<b>SECTION 1</b>	<b>SAFETY</b>	<b>1-1</b>
1.1	Safety Symbols.....	1-1
1.2	Safety Instructions.....	1-1
	<i>Safety Labels Description</i>	
<b>SECTION 2</b>	<b>GENERAL INFORMATION</b>	<b>2-1</b>
2.1	Installation and Setup.....	2-1
2.2	Overall Dimensions.....	2-3
<b>SECTION 3</b>	<b>OPERATION &amp; SETUP</b>	<b>3-1</b>
3.1	Operation.....	3-1
<b>SECTION 4</b>	<b>MAINTENANCE</b>	<b>4-1</b>
4.1	Gearbox Oil.....	4-1
4.2	Belt Alignment.....	4-1
4.3	Drive Chain Adjustment.....	4-1
<b>SECTION 5</b>	<b>REPLACEMENT PARTS</b>	<b>5-1</b>
5.1	Idle Side Pulley & Rollers.....	5-1
5.2	Motor & Drive Roller.....	5-1
5.3	Legs.....	5-1
5.4	Decals.....	5-1
<b>SECTION 6</b>	<b>ELECTRICAL INFORMATION</b>	<b>6-1</b>
6.1	Electrical Symbol Diagram IC-70.....	6-1
6.2	Electrical Symbol Diagram IC-300.....	6-2

## SECTION 1 SAFETY

### 1.1 Safety Symbols

The following symbols and signal words call your attention to instructions concerning your personal safety. Be sure to observe and follow these instructions.

 **DANGER!** indicates an imminently hazardous situation which, if not avoided, will result in death or serious injury.

 **WARNING!** suggests a potentially hazardous situation which, if not avoided, could result in death or serious injury.

 **CAUTION!** refers to potentially hazardous situations which, if not avoided, may result in minor or moderate injury or damage to equipment.

 **IMPORTANT!** indicates vital information.

**NOTE:** gives helpful information.

 Warning stripes are placed on areas where a single decal would be insufficient. To avoid serious injury, keep out of the path of any equipment marked with warning stripes.

## 1.2 Safety Instructions

**NOTE:** ONLY safety instructions regarding personal injury are listed in this section. Caution statements regarding only equipment damage appear where applicable throughout the manual.

### OBSERVE SAFETY INSTRUCTIONS

 **IMPORTANT!** Read the entire Operator's Manual before operating the conveyor. Take notice of all safety warnings throughout this manual and those posted on the machine. Keep this manual with this machine at all times, regardless of ownership.

Also read any additional manufacturer's manuals and observe any applicable safety instructions including dangers, warnings, and cautions.

Only persons who have read and understood the entire operator's manual should operate the conveyor. The conveyor is not intended for use by or around children.

**IMPORTANT!** It is always the owner's responsibility to comply with all applicable federal, state and local laws, rules and regulations regarding the ownership, operation of your Wood-Mizer products. All Wood-Mizer product owners are encouraged to become thoroughly familiar with these applicable laws and comply with them fully while using the machine.



# 1 Safety

## Safety Labels Description

---

### KEEP CONVEYOR AND AREA AROUND CONVEYOR CLEAN

 **DANGER!** Maintain a clean and clear path for all necessary movement around the machine and lumber stacking areas. Failure to do so will result in serious injury.

### CAUTIONS FOR CONVEYOR SETUP

**WARNING!** Securely fasten the feet of an incline conveyor to the floor before operating the machine. Failure to do so may result in serious injury or death.

### CHECK CONVEYOR BEFORE OPERATION

 **DANGER!** Make sure all guards and covers are in place and secured before operating the conveyor. Failure to do so may result in serious injury.



### KEEP PERSONS AWAY

 **WARNING!** Keep all persons out of the path of moving equipment and boards while operating conveyor. Failure to do so may result in serious injury or death.



### SAFETY LABELS DESCRIPTION

See Table 1-1. Pictographic safety labels are shown in the table below.

**TABELA 1-1**

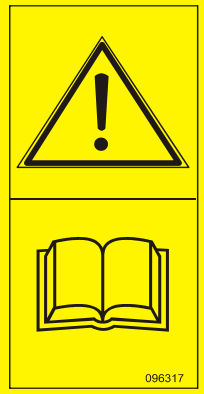

Decal View	Decal No.	Description
------------	-----------	-------------

**TABELA 1-1**

	<p>096317</p>	<p>Read thoroughly the operator's manual before operating the equipment. Observe instructions and safety rules when operating.</p>
	<p>099220</p>	<p>Close all guards and covers prior to starting the equipment.</p>
	<p>099221</p>	<p>Keep all persons a safe distance away from work area when operating the unit.</p>

**1** Safety  
*Safety Labels Description*

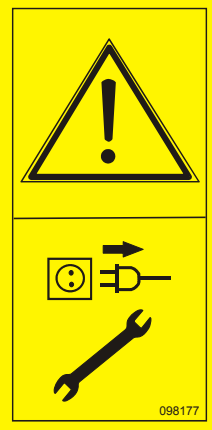
**TABELA 1-1**

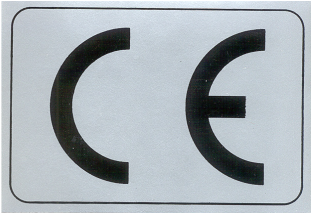
	<p>098177</p>	<p>Disconnect power supply before servicing.</p>
	<p>099540</p>	<p>CAUTION! Gear danger – keep a safe distance away!</p>
	<p>P85070</p>	<p>CE safety certification</p>



## SECTION 2 GENERAL INFORMATION

### 2.1 Installation and Setup

The Incline Conveyor allows you to quickly transport boards away from your Wood-Mizer sawmill. The following manual will guide you in installation, operation, and maintenance of the Incline Conveyor.



**WARNING!** Keep all persons out of the path of moving equipment and boards while operating conveyor. Failure to do so may result in serious injury or death.

See Figure 2-1. The major components of the Incline Conveyor are identified below.

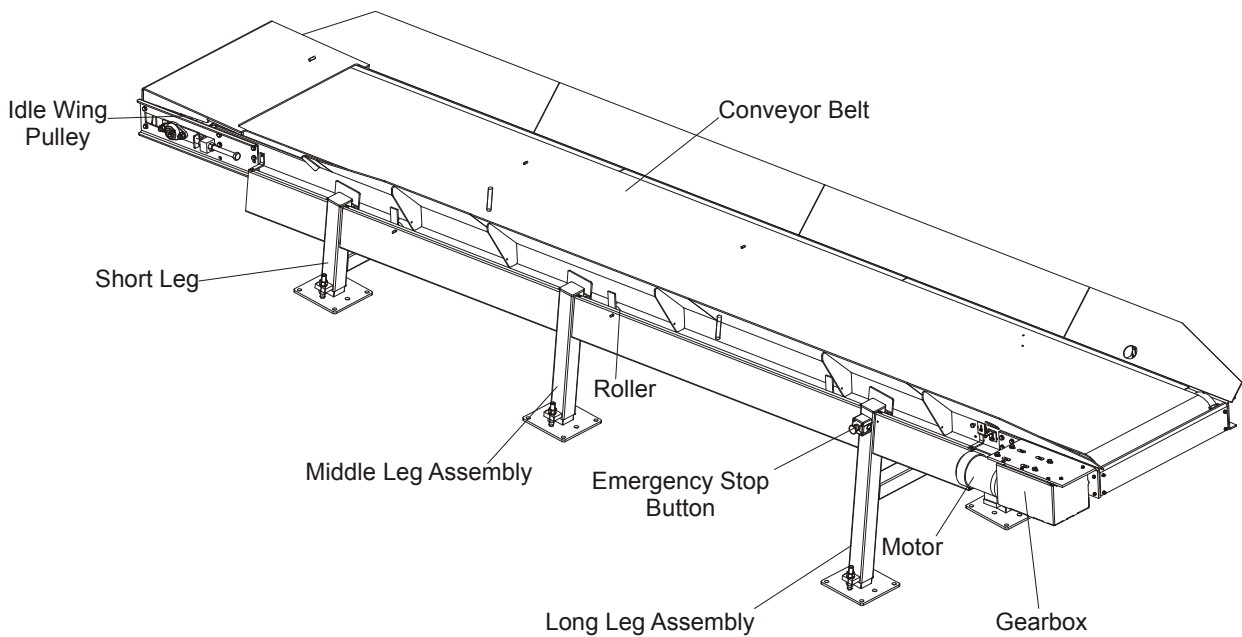

**FIG. 2-1**

See Table 2-1. See the table below for the Incline Conveyor motor specifications.

	<b>Motor Specifications</b>
<b>Motor Type</b>	Electric Motor
<b>Manufacturer</b>	
<b>Voltage</b>	400V 50Hz
<b>Maximum Current</b>	4 A

**TABLE 2-1**

## **2** GENERAL INFORMATION

### *Installation and Setup*

---

<b>Motor RPM</b>	
<b>Rated Output</b>	1,5kW ( 2HP )
<b>Model</b>	Skh-80X-4D1
<b>WM Part #</b>	095064
<b>Belt linear speed</b>	1,3 m/s

**TABLE 2-1**

## **2.2 Overall Dimensions**

See **Figure 2-2**. The overall dimensions of the Incline Conveyor (IC1) and leg layout are

## 2 General Information

### Overall Dimensions

shown below.

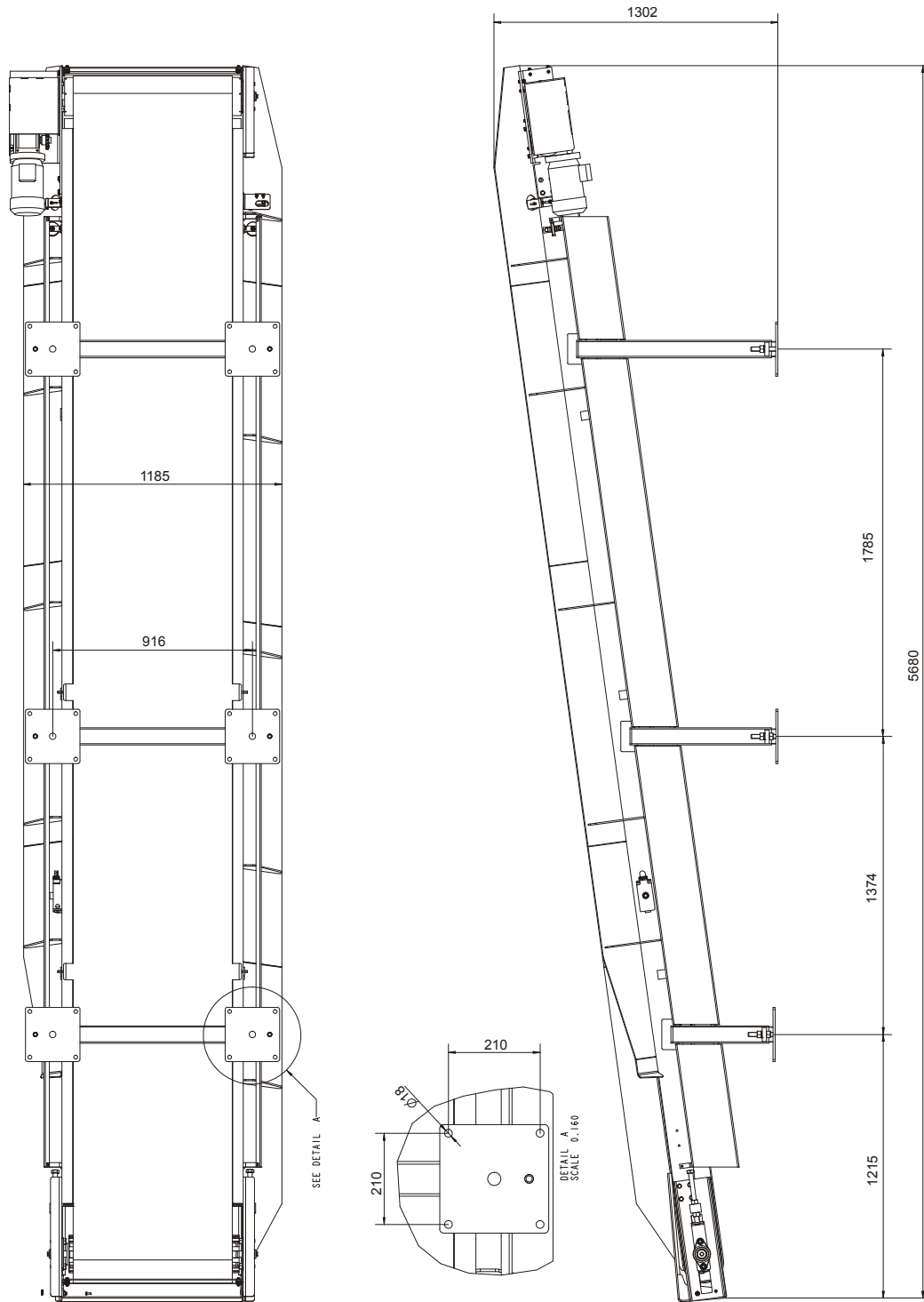

**FIG. 2-2 INCLINE CONVEYOR (IC1)**

See Figure 2-3. Weight are listed below.

Model	Weight
IC1	700 kg

## SECTION 3 OPERATION & SETUP

### 3.1 Operation

After the control box is installed you can start operating the incline conveyor.

**See Figure 3-1.** The following switch and buttons are located on the front door of the conveyor control box.



**FIG. 3-1**

#### **Drive Roller Motor Start**

1. Turn the Main Disconnect Switch to the "ON" position.
2. Push the green roller motor START button.

#### **Drive Roller Motor Shutoff**

3. Push the red roller motor STOP button.

Turn the Main Disconnect Switch to the "OFF" position to turn off electrical power to the conveyor control box if necessary.

## SECTION 4 MAINTENANCE



**DANGER!** Always be aware of and take proper protective measures against rotating shafts, pulleys, fans, etc. Always stay a safe distance from rotating members and make sure that loose clothing or long hair does not engage rotating members resulting in possible injury.

**WARNING!** Always wear proper and necessary safety equipment when performing service functions. Proper safety equipment includes eye protection, breathing protection, hand protection and foot protection.



**This symbol** identifies the interval (hours of operation) at which each maintenance procedure should be performed. "AR" signifies maintenance procedures which should be performed as required.

### 4.1 Gearbox Oil



Check the gearbox oil level. Add a synthetic gear oil such as Mobil SHC 634 as needed.

The Mobil SHC 634 gear oil is a synthesized hydrocarbon formulated used for extremely long life. Change oil only when performing maintenance that requires gearbox disassembly.

If oil must be replaced, use only Mobil SHC 634.

Wood-Mizer offers replacement gear oil in 8 ounce bottles.

## 4.2 Belt Alignment



The Incline Conveyor is factory-aligned. Periodically check and realign the conveyor belt if necessary. Make sure the belt remains centered on the drive roller and idle wing pulley while running. If the conveyor belt keeps travelling to the side of the drive roller and/or idle wing pulley follow the realignment procedure below.

To realign the conveyor belt:

4. Loosen the jam nuts on one or both idle wing pulley alignment bolts.

See Figure 4-1.

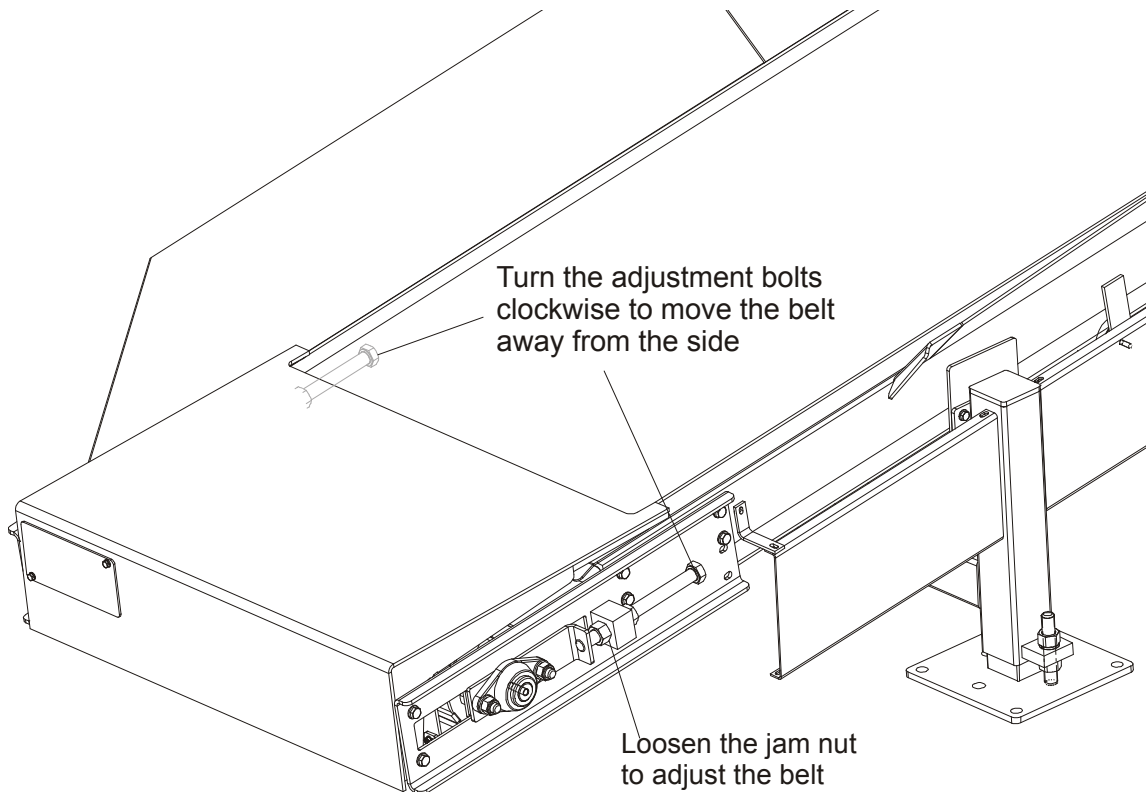

**FIG. 4-1**

5. Turn one of the alignment bolts clockwise to move the idle wing pulley downward and away from the side. Turn the alignment bolt counterclockwise to move the idle wing pulley upward.
6. Start the drive roller motor and check if the conveyor belt still needs to be aligned. Repeat the steps until the conveyor belt stays in place on the drive roller and idle wing pulley



while running.

7. Tighten the jam nuts when the belt alignment procedure is complete.

**NOTE:** You can also use the three adjustment nuts and bolts securing one side of the drive roller bearing bracket to adjust the conveyor belt. To adjust the conveyor belt, loosen the three adjustment nuts and move the bracket to tighten or loosen the belt if necessary. Make sure the belt remains on the drive roller and the idle wing pulley while running.

Tighten the adjustment nuts when the belt realignment procedure is complete.



Periodically check the conveyor belt for wear. Replace a damaged or worn belt as needed. Always check the conveyor belt alignment after installing a new belt. Align the conveyor belt after replacing if necessary.

# 4

## Maintenance

### Drive Chain Adjustment

#### 4.3 Drive Chain Adjustment



Periodically check the incline conveyor drive chain tension. Adjust the drive chain tension as needed. The drive chain needs to be adjusted if the chain slack exceeds 1" (25.4mm).



**DANGER!** Always turn off and disconnect power supply before performing any service to the machine. Failure to do so may result in serious injury or death.

To check the drive chain tension, loosen the two bolts securing the drive chain front guard and remove the front guard.

See Figure 4-2.

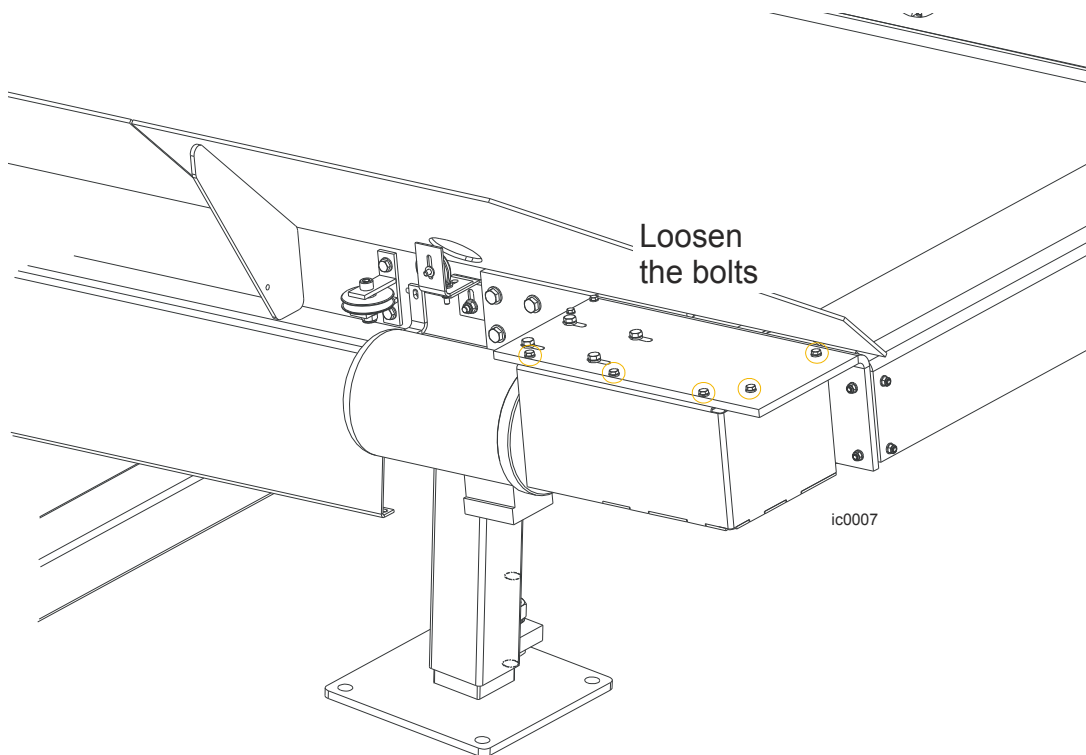

FIG. 4-2

To adjust the drive chain, follow the instructions below.

1. Make sure the motor is not running.
2. Loosen the four adjustment bolts securing the conveyor gearbox to the mount motor/gearbox bracket.
3. Move the gearbox and motor to adjust the drive chain until the center of the chain can be deflected 1/2" (12.7mm).

See Figure 4-3.

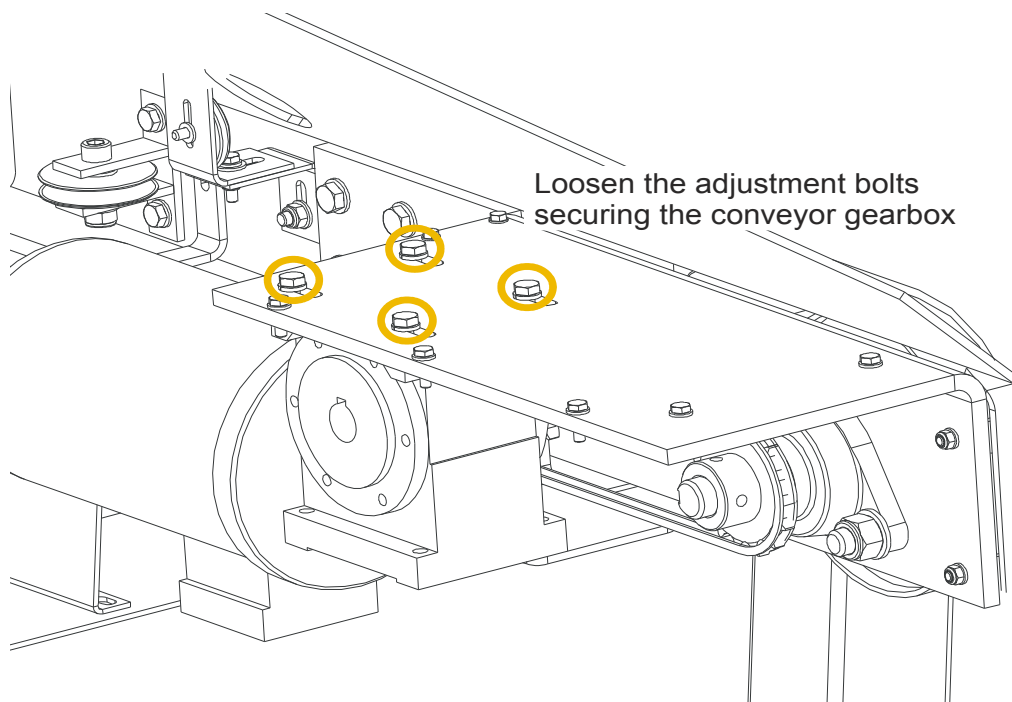

FIG. 4-3



**CAUTION!** Do not over-tension the conveyor drive chain.  
Damage to the gearbox will occur.

4. After the drive chain has been adjusted, tighten the gearbox adjustment bolts.
5. Reinstall the drive chain front guard and secure in place using the two washers and bolts.

## SECTION 5 REPLACEMENT PARTS

### 5.1 Idle Side Pulley & Rollers

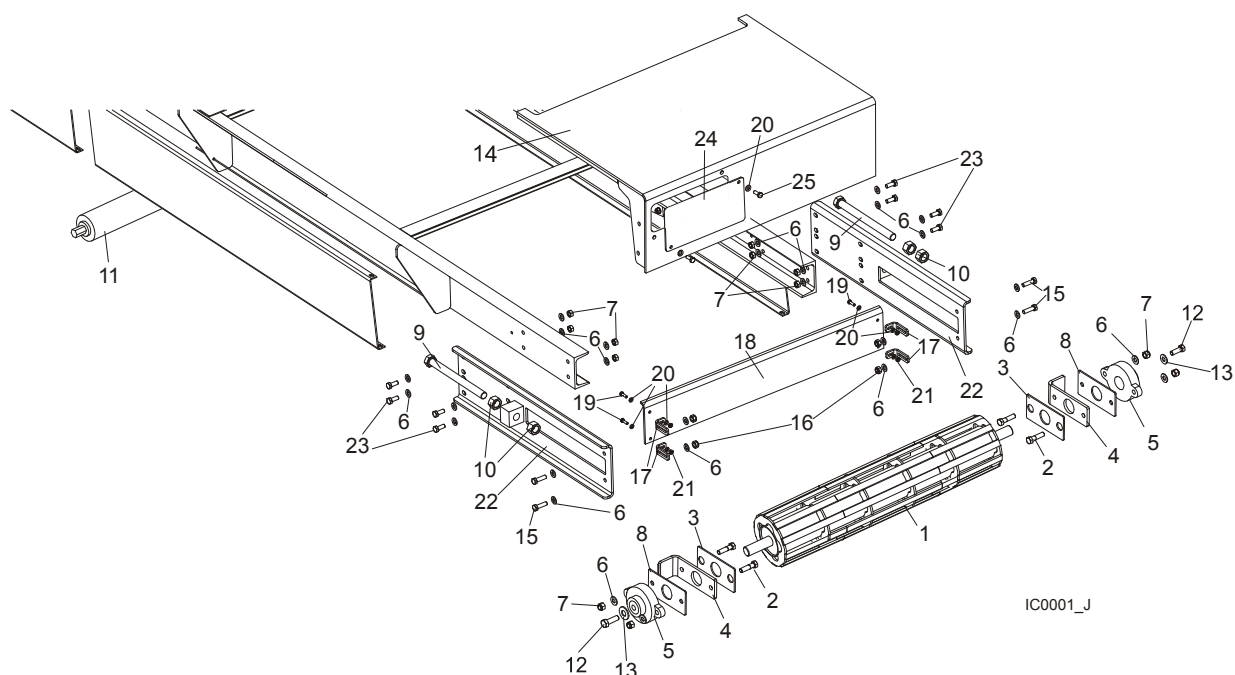

REF	DESCRIPTION (◆ Indicates Parts Available In Assemblies Only)	PART #	QTY.
1	PULLEY, IDLE SIDE	092970-1	1
2	BOLT, M10X50-8.8 HEX HEAD FULL THREAD ZINC	F81003-4	4
3	PLATE, CONVEYOR BELT TENSIONER	090854-1	2
4	BRACKET, CONVEYOR BELT TENSIONER	090853-1	2
5	BEARING, UCFL 206 CX BALL	090851	2
6	WASHER, 10.5 ZINC FLAT	F81055-1	28
7	NUT, M10-8-B ZINC HEX	F81033-3	12
8	PLATE, CONVEYOR BELT TENSIONER	090852-1	2
9	BOLT, M20X240-8.8 HEX HEAD FULL THREAD ZINC	F81007-8	2
10	NUT, M20-8 ZINC HEX	F81037-1	4
11	ROLLER, 76MM DIAMETER	090843-1	4
12	BOLT, M10x16-8.8	F81003-13	2
13	WASHER, ZINC	088059-1	2
14	GUARD, CONVEYOR BELT	096692-1	1
15	BOLT, M10X35-8.8 HEX HEAD FULL THREAT	F81003-17	4
16	NUT, M10-8-B NYLON HEX ZINC LOCK	F81033-1	4
17	BRACKET, COVER 2 - PTD	092419-1	4
18	COVER, CONVEYOR BELT-PTD	092423-1	1
19	BOLT, M6X20-8.8 HEX HEAD FULL THREAD ZINC	F81001-2	4

**Replacement Parts**  
*Idle Side Pulley & Rollers*

**5**

20	WASHER, 6.4 ZINC FLAT	F81053-1	10	
21	NUT, M6-8-B HEX NYLON ZINC LOCK	F81031-2	4	
22	TENSIONER, BELT	505831-1	2	
23	Bolt, M10-1.5x25mm HH Gr8.8	F81003-11	4	
24	PLATE MASKING CONVEYOR BELT IC1	511114-1	1	
25	BOLT, M6 x 16 8.8 Fe/Zn5 PN-M/82105	F81001-15	2	



# Replacement Parts

## Motor & Drive Roller

### 5.2 Motor & Drive Roller

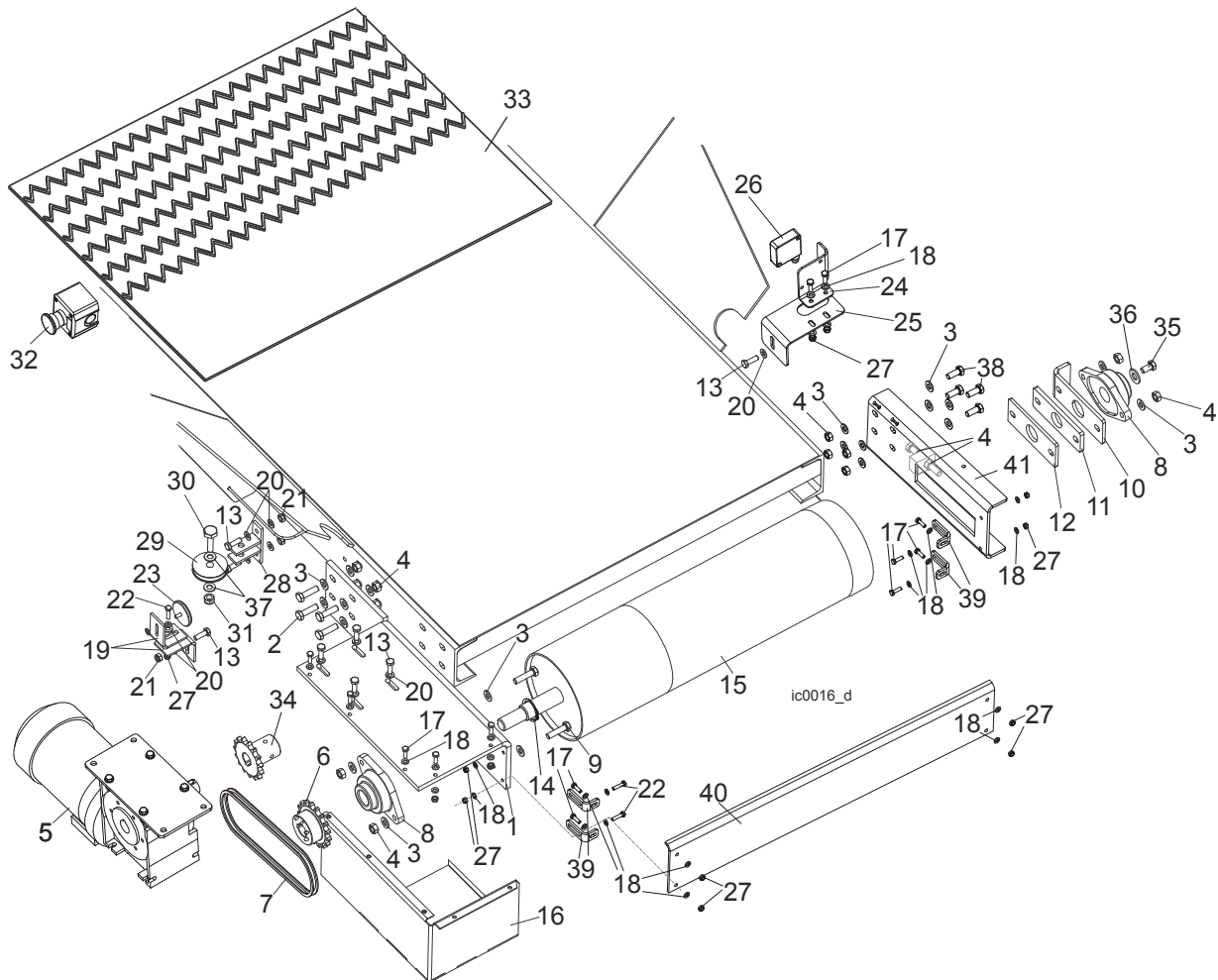

REF	DESCRIPTION (◆ Indicates Parts Available In Assemblies Only)	PART #	QTY.
1	BRACKET, IC GEAR BOX MOUNT	090848-1	1
2	BOLT, M10x35-8.8 HEX HEAD FULL THREAD ZINC	F81003-17	4
3	WASHER, 10.5 ZINC FLAT	F81055-1	18
4	NUT, M10-8-B ZINC HEX	F81033-3	14
5	MOTOREDUCER W/PLATE COMPLETE	503079	1
	GEAR BOX, MR63/10/1,5-1400K3/N+S/B3	504859	1
	MOTOR, Skh-80X-4D1	095064	1
	REDUCER MR63/10/DS-160/19-WJ1/B3	083806	1
	PLATE, MOTOREDUCER WITH IC1	503078-1	1
	BOLT, M8X30MM, HH, GR 5.8, FULL THRD, ZINC	F81002-2	4
	NUT, M8-8-B HEX NYLON ZINC LOCK	F81032-2	4
	WASHER, 8.4 FLAT ZINC	F81054-1	8

6	SPROCKET, 10B Z15	092956-1	2	
7	CHAIN, 10B-52PZ TRANSMISSION ROLLER	092957	1	
8	BEARING, UCFL 206 CX BALL	090851	2	
9	BOLT, M10x40-8.8 HEX HEAD FULL THREAD ZINC	F81003-16	4	
10	BRACKET, CONVEYOR BELT TENSIONER	090914-1	1	
11	PLATE, CONVEYOR BELT TENSIONER	090852-1	1	
12	PLATE, CONVEYOR BELT TENSIONER	090854-1	1	
13	BOLT, M8X25-8.8-B HEX HEAD FULL THREAD ZINC	F81002-5	10	
14	RING, Z30 SPRING RETAINING	F81090-23	1	
15	PULLEY, DRIVE SIDE	090846	1	
16	GUARD, IC MOTOREDUCER	095167-1	1	
17	BOLT, M6X20-8.8 HEX HEAD FULL THREAD ZINC	F81001-2	13	
18	WASHER, 6.4 ZINC FLAT	F81053-1	28	
19	BRACKET, PHOTO SENSOR RECEIVER MOUNT	091405	2	
20	WASHER, 8.4 ZINC FLAT	F81054-1	4	
21	NUT, M8-8-B HEX NYLON ZINC LOCK	F81032-2	6	
22	BOLT, M6x25-5.8 HEX HEAD FULL THREAD ZINC	F81001-3	3	
23	SENSOR, PHOTO RECEIVER	091401	1	
24	PLATE, PHOTO SENSOR TRANSMITTER MOUNT	093991-1	1	
25	BRACKET, PHOTO SENSOR TRANSMITTER	094646-1	1	
26	SENSOR, XUK1APANM12 PHOTO TRANSMITTER	093169	1	
27	NUT, M6-8-B HEX NYLON ZINC LOCK	F81031-2	11	
28	BRACKET, CABLE GUIDE PULLEY MOUNT	091787-1	2	
29	PULLEY, CABLE GUIDE	091273-1	2	
30	BOLT, M12X55-8.8 HEX HEAD ZINC	F81004-12	2	
31	NUT, M10-8-B HEX NYLON ZINC LOCK	F81033-1	3	
32	SWITCH, EMERGENCY XALJ174F	E22703-P	2	
33	BELT, 2M0P3LG 11400X730 INCLINE CONVEYOR	090847	1	
34	SPROCKET, 10B Z15	095162	1	
35	BOLT, M10X16-8.8	F81003-13	1	
36	WASHER, ZINC	088059-1	1	
37	WASHER, 13 FLAT ZINC	F81056-1	4	
38	Bolt, M10-1.5x25mm HH Gr8.8	F81003-11	4	
39	BRACKET, COVER 2 - PTD	092419-1	4	
40	COVER, CONVEYOR BELT-PTD	092423-1	1	
41	TENSIONER, BELT 3	090913-1	1	
	ROLLER COVERING, 50M.	R00100	10,5m	
	ADHESIVE, "TEXCOL" 1KG PACKAGE	090875	1kg	



# Replacement Parts

## Legs

### 5.3 Legs

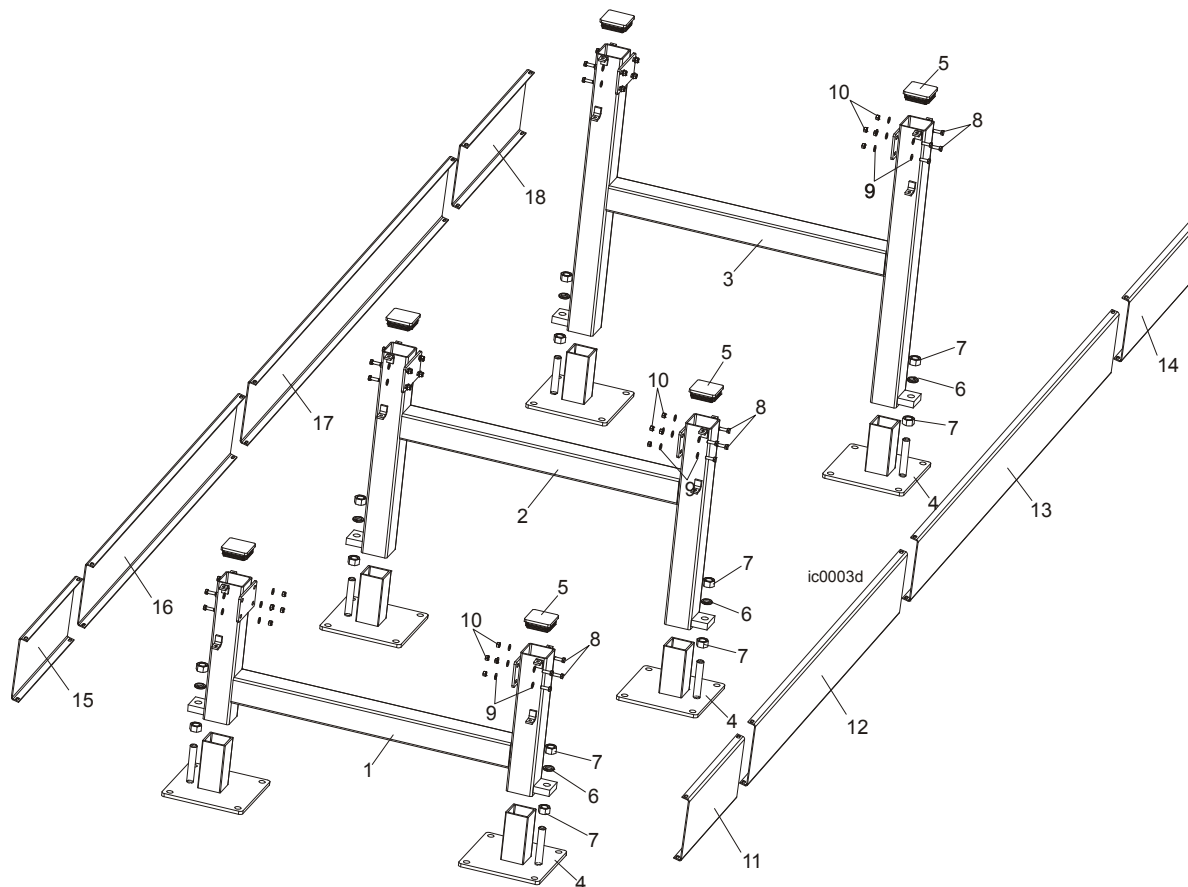

REF	DESCRIPTION (◆ Indicates Parts Available In Assemblies Only)	PART #	QTY.
	<b>LEG ASSEMBLY, INCLINE CONVEYOR SHORT</b>	090876	1
1	Leg Weldment, IC Short - Upper Part	090880-1	1
	<b>LEG ASSEMBLY, INCLINE CONVEYOR MIDDLE</b>	090881	1
2	Leg Weldment, IC Middle - Upper Part	090883-1	1
	<b>LEG ASSEMBLY, INCLINE CONVEYOR LONG</b>	090886	1
3	Leg Weldment, IC Long - Upper Part	090885-1	1
4	<b>LEG WELDMENT, IC - LOWER PART</b>	512225-1	6
5	<b>CAP, #199247 TUBE END</b>	089644	6
6	<b>WASHER, 20.5 ZINC SPLIT LOCK</b>	F81059-1	6
7	<b>NUT, M20-8 ZINC HEX</b>	F81037-1	12
8	<b>BOLT, M8X25-8.8-B HEX HEAD FULL THREAD ZINC</b>	F81002-5	24
9	<b>WASHER, 8.4 ZINC FLAT</b>	F81054-1	48
10	<b>NUT, M8-8-B ZINC HEX</b>	F81032-1	24
11	<b>COVER, CONVEYOR BELT 6 -PTD</b>	092442-1	1
12	<b>COVER, CONVEYOR BELT 5 -PTD</b>	092438-1	1



# Replacement Parts

*Legs*

**5**

---

13	COVER, CONVEYOR BELT1 4 -PTD	092445-1	1	
14	COVER, CONVEYOR BELT 8	505815-1	1	
15	COVER, CONVEYOR BELT 3 -PTD	092440-1	1	
16	COVER, CONVEYOR BELT - PTD	092439-1	1	
17	COVER, CONVEYOR BELT 6 -PTD	092437-1	1	
18	COVER, CONVEYOR BELT 7	505833-1	1	

# 5 Replacement Parts

## Decals

### 5.4 Decals

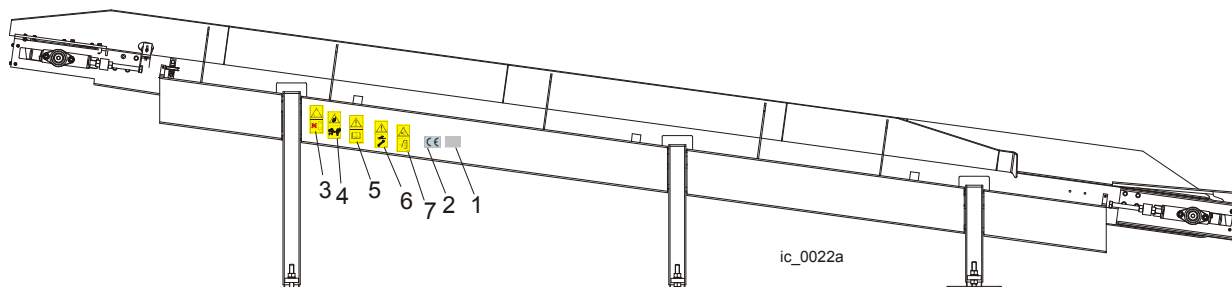

REF	DESCRIPTION (◆ Indicates Parts Available In Assemblies Only)	PART #	QTY.
1	DECAL, SERIAL NUMBER	-----	1
	DECALS KIT, IC	503670	1
2	Decal, CE Certified Ssawmill	P85070	1
3	Decal, Gear Caution	099540	1
4	Decal, Keep a Safe Distance Away	099221	1
5	Decal, Read the Operator's Manual	096317	1
6	Decal, Disconnect Power Supply Before Servicing	098177	1
7	Decal, Close All Guards and Covers Before Starting the Machine	099220	1



## 6.2 Electrical Symbol Diagram IC-300

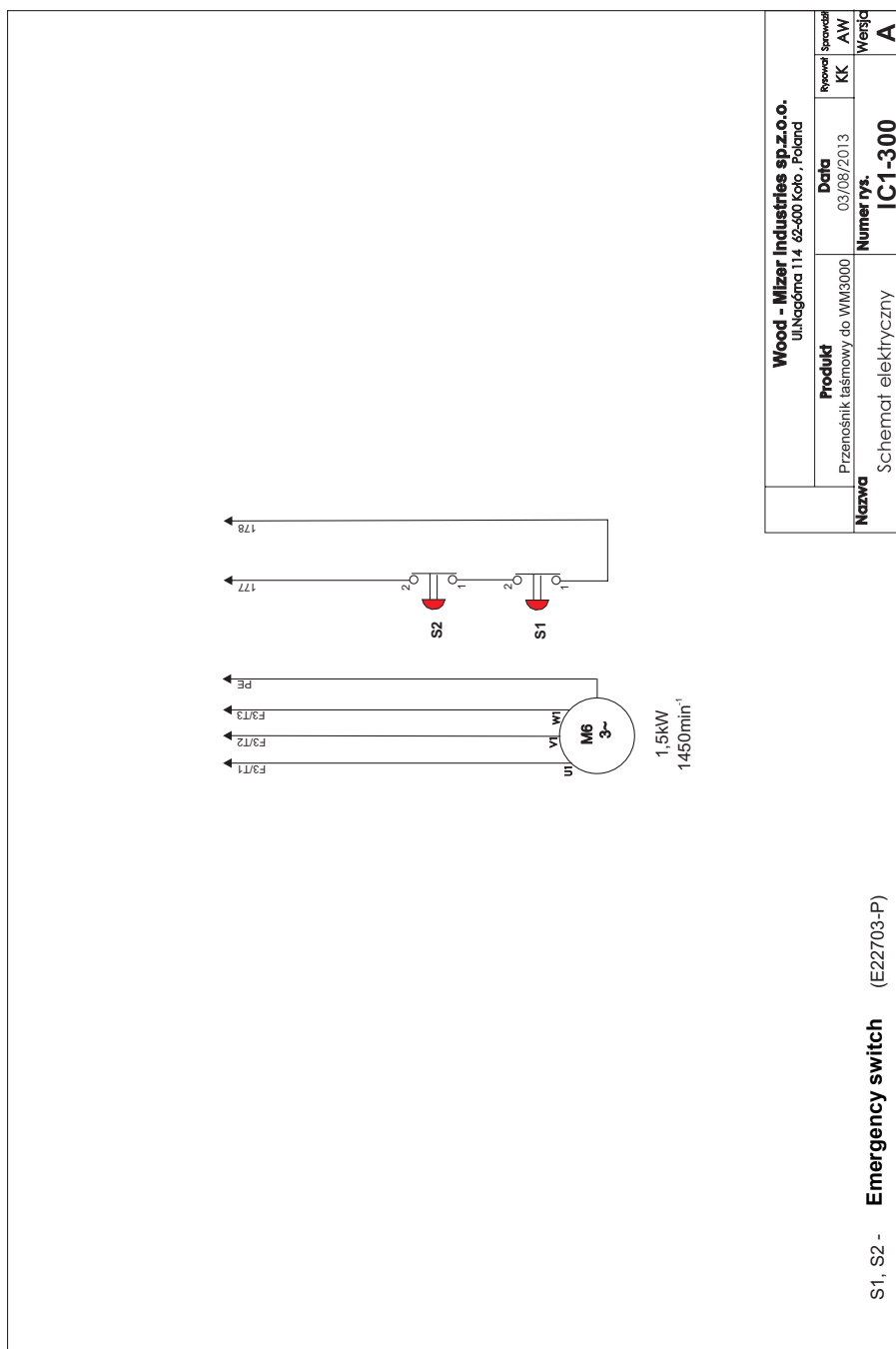

**FIG. 6-2**

## EC declaration of conformity according to EC Machinery Directive 2006/42/EC

We herewith declare,

Wood-Mizer Industries sp. Z O.O.  
114 Nagorna street, 62-600 Kolo; Poland.

That the following described machine in our delivered version complies with the appropriate basic safety and health requirements of the EC Machinery Directive 2006/42/EC based on its design and type, as brought into circulation by us. In case of alteration of the machine, not agreed by us, this declaration is no longer valid.

Designation of the machine: **Incline Conveyor**  
TYPE: IC1  
No. of manufacturer: .....

Applicable EC Directives: EC Machinery Directive 2006/42/EC  
EC Low-Voltage Directive 2006/95/EC  
EC Electromagnetic Compatibility Directive  
2004/108/EC

Responsible for Technical Documentation: Roman Frontczak / R&D Director

Date/Authorized Signature: 29. 12. 2009   
Title : R&D Director