

Incline Conveyor

Safety, Setup, Operation & Maintenance Manual

CB3

rev. A2.01



Safety is our #1 concern! Read and understand all safety information and instructions before operating, setting up or maintaining this machine.

Form #1121

Table of Contents

Section-Page

SECTION 1	SAFETY	1-1
1.1	Safety Symbols.....	1-1
1.2	Safety Instructions.....	1-2
	<i>Safety Labels Description</i>	
SECTION 2	GENERAL INFORMATION	2-1
2.1	Installation and Setup	2-1
2.2	Overall Dimensions	2-3
SECTION 3	OPERATION & SETUP	3-1
3.1	Operation	3-1
SECTION 4	MAINTENANCE	4-1
4.1	Gearbox Oil	4-1
4.2	Belt Alignment	4-2
4.3	Drive Chain Adjustment.....	4-4
SECTION 5	REPLACEMENT PARTS	5-1
5.1	Idle Side Pulley & Rollers.....	5-1
5.2	Motor & Drive Roller.....	5-3
5.3	Legs	5-5
5.4	Decals	5-7
5.5	CB3-WB Incline Conveyor	5-9
5.6	Roller Set, CB3.....	5-10
5.7	Pulley Support Kit	5-11
5.8	Belt Kit with Rollers, CB3	5-13
5.9	Motor Kit, CB3.....	5-14
5.10	Cover, Incline Conveyor	5-16
5.11	Leg Set, CB3-2000	5-17
5.12	Cover Set, CB3-2000.....	5-19

SECTION 1 SAFETY

1.1 Safety Symbols

The following symbols and signal words call your attention to instructions concerning your personal safety. Be sure to observe and follow these instructions.



DANGER! indicates an imminently hazardous situation which, if not avoided, will result in death or serious injury.



WARNING! suggests a potentially hazardous situation which, if not avoided, could result in death or serious injury.



CAUTION! refers to potentially hazardous situations which, if not avoided, may result in minor or moderate injury or damage to equipment.



IMPORTANT! indicates vital information.

NOTE: gives helpful information.



Warning stripes are placed on areas where a single decal would be insufficient. To avoid serious injury, keep out of the path of any equipment marked with warning stripes.

1.2 Safety Instructions

NOTE: ONLY safety instructions regarding personal injury are listed in this section. Caution statements regarding only equipment damage appear where applicable throughout the manual.

OBSERVE SAFETY INSTRUCTIONS

 **IMPORTANT!** Read the entire Operator's Manual before operating the conveyor. Take notice of all safety warnings throughout this manual and those posted on the machine. Keep this manual with this machine at all times, regardless of ownership.

Also read any additional manufacturer's manuals and observe any applicable safety instructions including dangers, warnings, and cautions.

Only persons who have read and understood the entire operator's manual should operate the conveyor. The conveyor is not intended for use by or around children.

IMPORTANT! It is always the owner's responsibility to comply with all applicable federal, state and local laws, rules and regulations regarding the ownership, operation of your Wood-Mizer products. All Wood-Mizer product owners are encouraged to become thoroughly familiar with these applicable laws and comply with them fully while using the machine.



KEEP CONVEYOR AND AREA AROUND CONVEYOR CLEAN

 **DANGER!** Maintain a clean and clear path for all necessary movement around the machine and lumber stacking areas. Failure to do so will result in serious injury.

CAUTIONS FOR CONVEYOR SETUP

WARNING! Securely fasten the feet of an incline conveyor to the floor before operating the machine. Failure to do so may result in serious injury or death.

CHECK CONVEYOR BEFORE OPERATION

 **DANGER!** Make sure all guards and covers are in place and secured before operating the conveyor. Failure to do so may result in serious injury.



KEEP PERSONS AWAY

 **WARNING!** Keep all persons out of the path of moving equipment and boards while operating conveyor. Failure to do so may result in serious injury or death.

SAFETY LABELS DESCRIPTION

See Table 1-1. Pictographic safety labels are shown in the table below.

TABELA 1-1

Decal View	Decal No.	Description

1 Safety

Safety Labels Description

TABELA 1-1





	<p>096317</p>	<p>Read thoroughly the operator's manual before operating the equipment. Observe instructions and safety rules when operating.</p>
	<p>099220</p>	<p>Close all guards and covers prior to starting the equipment.</p>
	<p>099221</p>	<p>Keep all persons a safe distance away from work area when operating the unit.</p>

TABELA 1-1

	<p>098177</p>	<p>Disconnect power supply before servicing.</p>
	<p>099540</p>	<p>CAUTION! Gear danger – keep a safe distance away!</p>
	<p>P85070</p>	<p>CE safety certification</p>

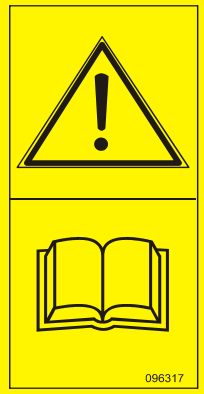
SECTION 2 GENERAL INFORMATION

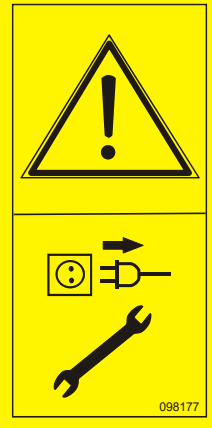
2.1 Installation and Setup

The Incline Conveyor allows you to quickly transport boards away from your Wood-Mizer sawmill. The following manual will guide you in installation, operation, and maintenance of the Incline Conveyor.

WARNING! Keep all persons out of the path of moving equipment and boards while operating conveyor. Failure to do so may result in serious injury or death.

See Figure 2-1. The major components of the Incline Conveyor are identified below.

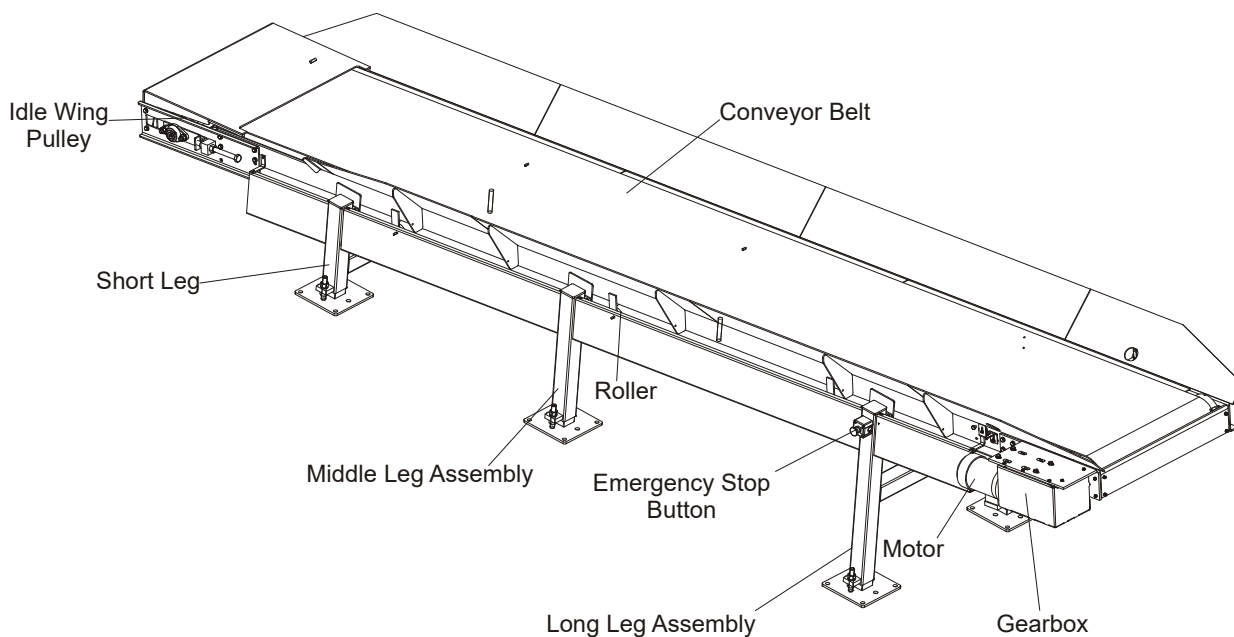

FIG. 2-1

See Table 2-1. See the table below for the Incline Conveyor motor specifications.

	Motor Specifications
Motor Type	Electric Motor
Manufacturer	
Voltage	400V 50Hz
Maximum Current	4 A

TABLE 2-1

Motor RPM	
Rated Output	1,5kW (2HP)
Model	Skh-80X-4D1
WM Part #	095064
Belt linear speed	1,3 m/s

TABLE 2-1

2 General Information

Overall Dimensions

2.2 Overall Dimensions

See **Figure 2-2**. The overall dimensions of the Incline Conveyor () and leg layout are

shown below.

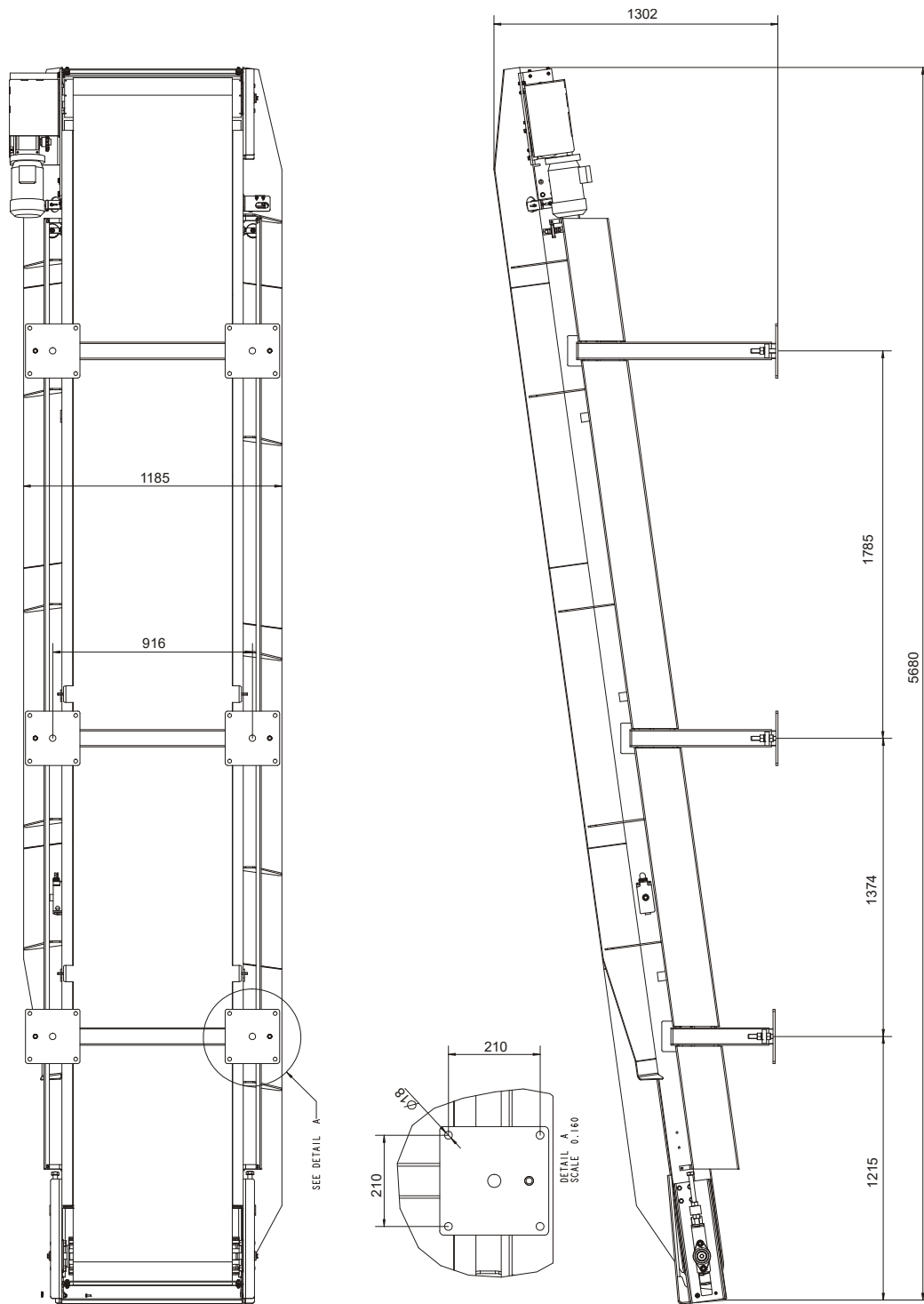

FIG. 2-2 INCLINE CONVEYOR (IC1)

2 General Information

Overall Dimensions

See Figure 2-3. Weight are listed below.

Model	Weight
CB3	700 kg

SECTION 3 OPERATION & SETUP

3.1 Operation

After the control box is installed you can start operating the incline conveyor.

See Figure 3-1. The following switch and buttons are located on the front door of the conveyor control box.



FIG. 3-1

Drive Roller Motor Start

1. Turn the Main Disconnecter Switch to the "ON" position.
2. Push the green roller motor START button.

Drive Roller Motor Shutoff

3. Push the red roller motor STOP button.

Turn the Main Disconnecter Switch to the "OFF" position to turn off electrical power to the conveyor control box if necessary.

SECTION 4 MAINTENANCE



DANGER! Always be aware of and take proper protective measures against rotating shafts, pulleys, fans, etc. Always stay a safe distance from rotating members and make sure that loose clothing or long hair does not engage rotating members resulting in possible injury.

WARNING! Always wear proper and necessary safety equipment when performing service functions. Proper safety equipment includes eye protection, breathing protection, hand protection and foot protection.



This symbol identifies the interval (hours of operation) at which each maintenance procedure should be performed. "AR" signifies maintenance procedures which should be performed as required.

4.1 Gearbox Oil



Check the gearbox oil level. Add a synthetic gear oil such as Mobil SHC 634 as needed.

The Mobil SHC 634 gear oil is a synthesized hydrocarbon formulated used for extremely long life. Change oil only when performing maintenance that requires gearbox disassembly.

If oil must be replaced, use only Mobil SHC 634.

Wood-Mizer offers replacement gear oil in 8 ounce bottles.

4.2 Belt Alignment

0 The Incline Conveyor is factory-aligned. Periodically check and realign the conveyor belt if necessary. Make sure the belt remains centered on the drive roller and idle wing pulley while running. If the conveyor belt keeps travelling to the side of the drive roller and/or idle wing pulley follow the realignment procedure below.

To realign the conveyor belt:

4. Loosen the jam nuts on one or both idle wing pulley alignment bolts.

See Figure 4-1.

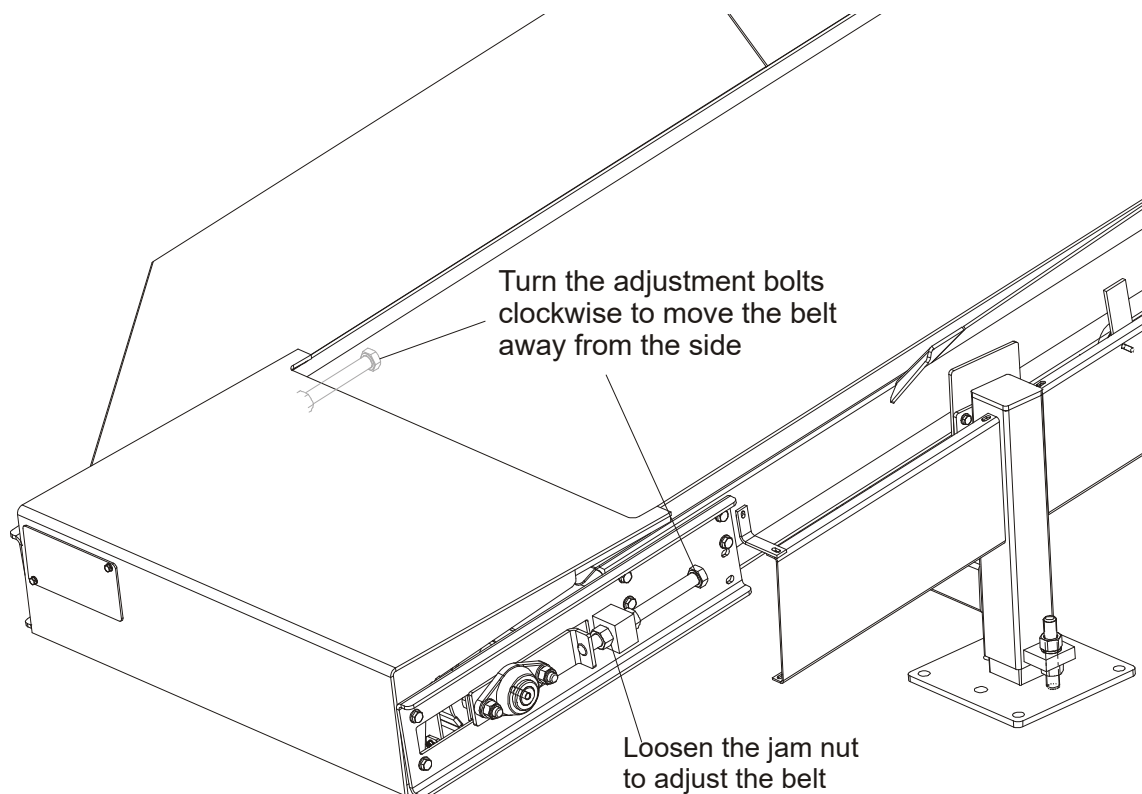

FIG. 4-1

5. Turn one of the alignment bolts clockwise to move the idle wing pulley downward and away from the side. Turn the alignment bolt counterclockwise to move the idle wing pulley upward.
6. Start the drive roller motor and check if the conveyor belt still needs to be aligned. Repeat the steps until the conveyor belt stays in place on the drive roller and idle wing pulley

4

Maintenance

Belt Alignment

while running.

7. Tighten the jam nuts when the belt alignment procedure is complete.

NOTE: You can also use the three adjustment nuts and bolts securing one side of the drive roller bearing bracket to adjust the conveyor belt. To adjust the conveyor belt, loosen the three adjustment nuts and move the bracket to tighten or loosen the belt if necessary. Make sure the belt remains on the drive roller and the idle wing pulley while running.

Tighten the adjustment nuts when the belt realignment procedure is complete.



Periodically check the conveyor belt for wear. Replace a damaged or worn belt as needed. Always check the conveyor belt alignment after installing a new belt. Align the conveyor belt after replacing if necessary.

4.3 Drive Chain Adjustment

0 Periodically check the incline conveyor drive chain tension. Adjust the drive chain tension as needed. The drive chain needs to be adjusted if the chain slack exceeds 1" (25.4mm).

 **DANGER!** Always turn off and disconnect power supply before performing any service to the machine. Failure to do so may result in serious injury or death.

To check the drive chain tension, loosen the two bolts securing the drive chain front guard and remove the front guard.

See Figure 4-2.

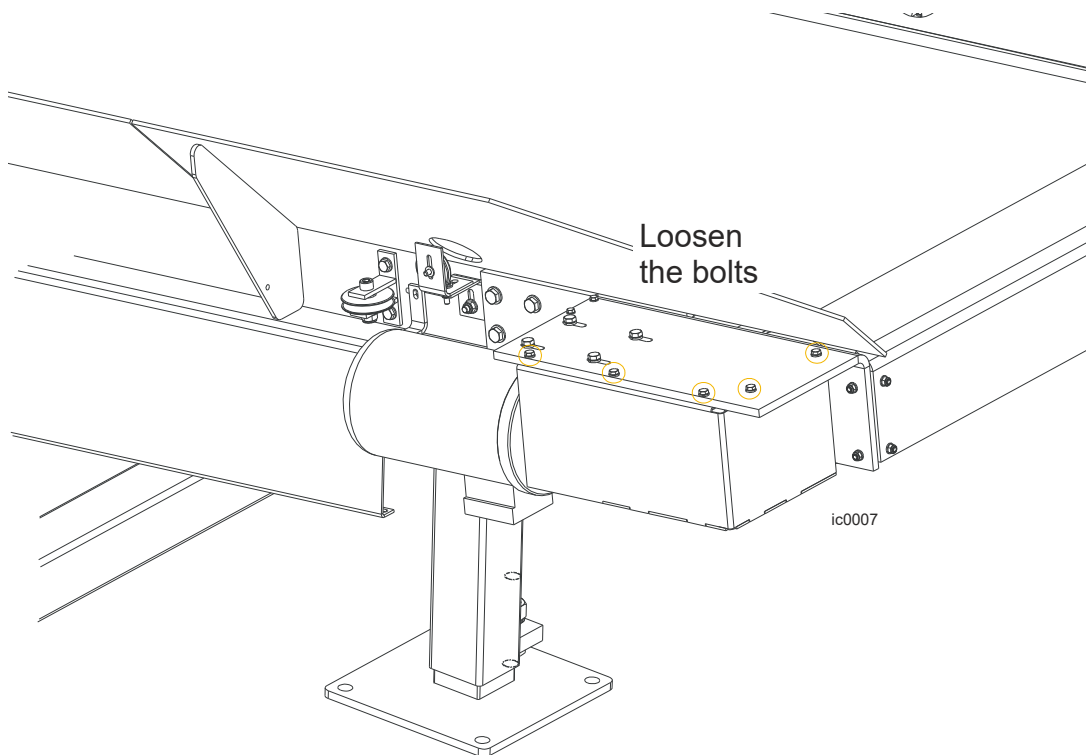

FIG. 4-2

4

Maintenance

Drive Chain Adjustment

To adjust the drive chain, follow the instructions below.

1. Make sure the motor is not running.
2. Loosen the four adjustment bolts securing the conveyor gearbox to the mount motor/gearbox bracket.
3. Move the gearbox and motor to adjust the drive chain until the center of the chain can be deflected 1/2" (12.7mm).

See Figure 4-3.

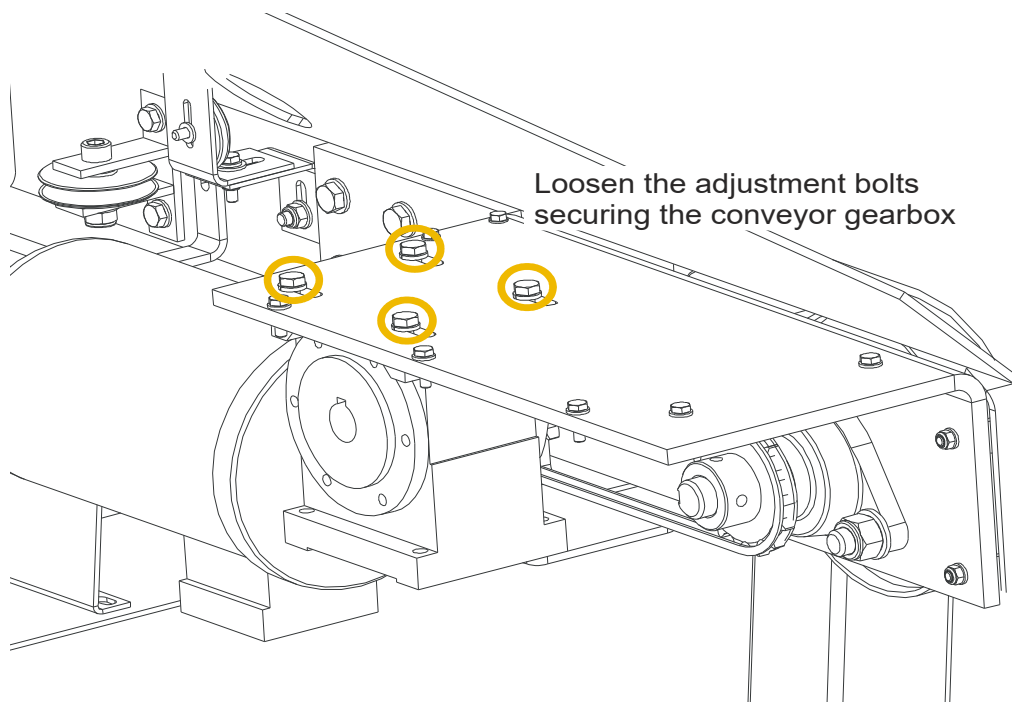

FIG. 4-3



CAUTION! Do not over-tension the conveyor drive chain. Damage to the gearbox will occur.

4. After the drive chain has been adjusted, tighten the gearbox adjustment bolts.
5. Reinstall the drive chain front guard and secure in place using the two washers and bolts.

SECTION 5 REPLACEMENT PARTS

5.1 Idle Side Pulley & Rollers

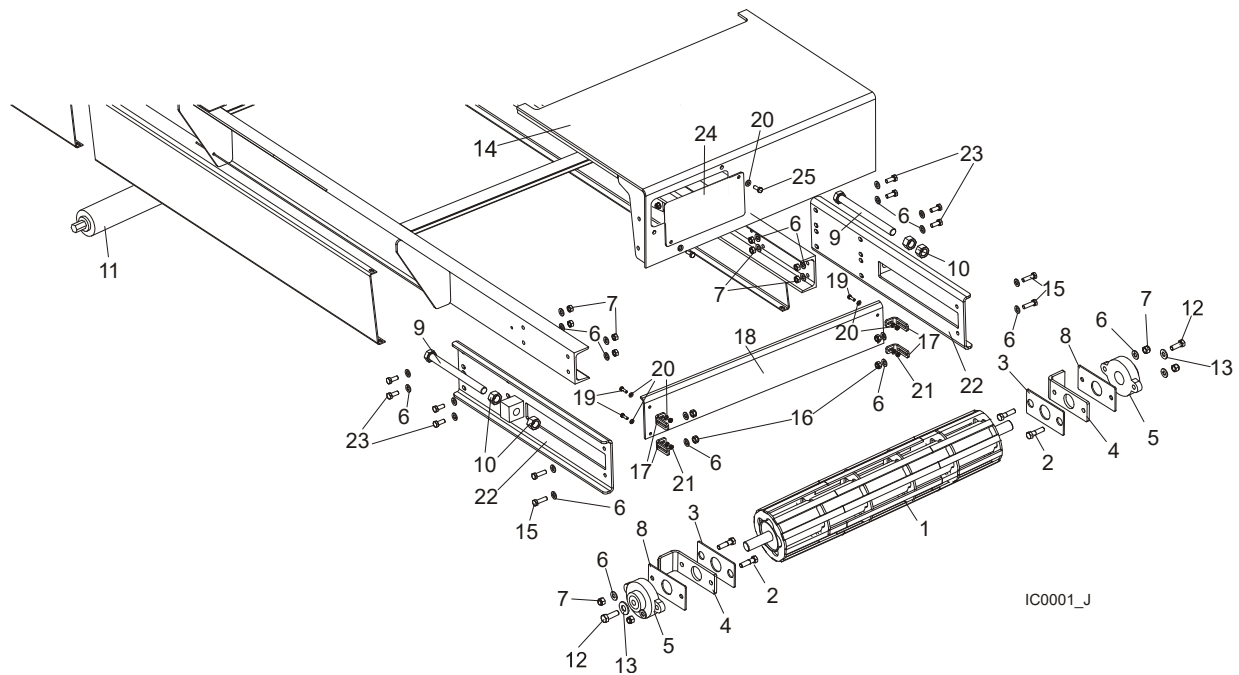

REF.	DESCRIPTION (◆ Indicates Parts Available In Assemblies Only)	PART #	QTY
1	PULLEY, IDLE SIDE	092970-1	1
2	BOLT, M10X50-8.8 HEX HEAD FULL THREAD ZINC	F81003-4	4
3	PLATE, CONVEYOR BELT TENSIONER	090854-1	2
4	BRACKET, CONVEYOR BELT TENSIONER	090853-1	2
5	BEARING, UCFL 206 CX BALL	090851	2
6	WASHER, 10.5 ZINC FLAT	F81055-1	28
7	NUT, M10-8-B ZINC HEX	F81033-3	12
8	PLATE, CONVEYOR BELT TENSIONER	090852-1	2
9	BOLT, M20X240-8.8 HEX HEAD FULL THREAD ZINC	F81007-8	2
10	NUT, M20-8 ZINC HEX	F81037-1	4
11	ROLLER, 76MM DIAMETER	090843-1	4
12	BOLT, M10x16-8.8	F81003-13	2
13	WASHER, ZINC	088059-1	2
14	GUARD, CONVEYOR BELT	096692-1	1
15	BOLT, M10X35-8.8 HEX HEAD FULL THREAT	F81003-17	4
16	NUT, M10-8-B NYLON HEX ZINC LOCK	F81033-1	4
17	BRACKET, COVER 2 - PTD	092419-1	4
18	COVER, CONVEYOR BELT-PTD	092423-1	1
19	BOLT, M6X20-8.8 HEX HEAD FULL THREAD ZINC	F81001-2	4

5 Replacement Parts

Idle Side Pulley & Rollers

20	WASHER, 6.4 ZINC FLAT	F81053-1	10	
21	NUT, M6-8-B HEX NYLON ZINC LOCK	F81031-2	4	
22	TENSIONER, BELT	505831-1	2	
23	BOLT, M10x25-8.8 HEX HEAD FULL THREAD ZINC	F81003-11	4	
24	PLATE, CB3 COVER	511114-1	1	
25	BOLT, M6 x 16 8.8 HEX HEAD FULL THREAD ZINC	F81001-15	2	

5.2 Motor & Drive Roller

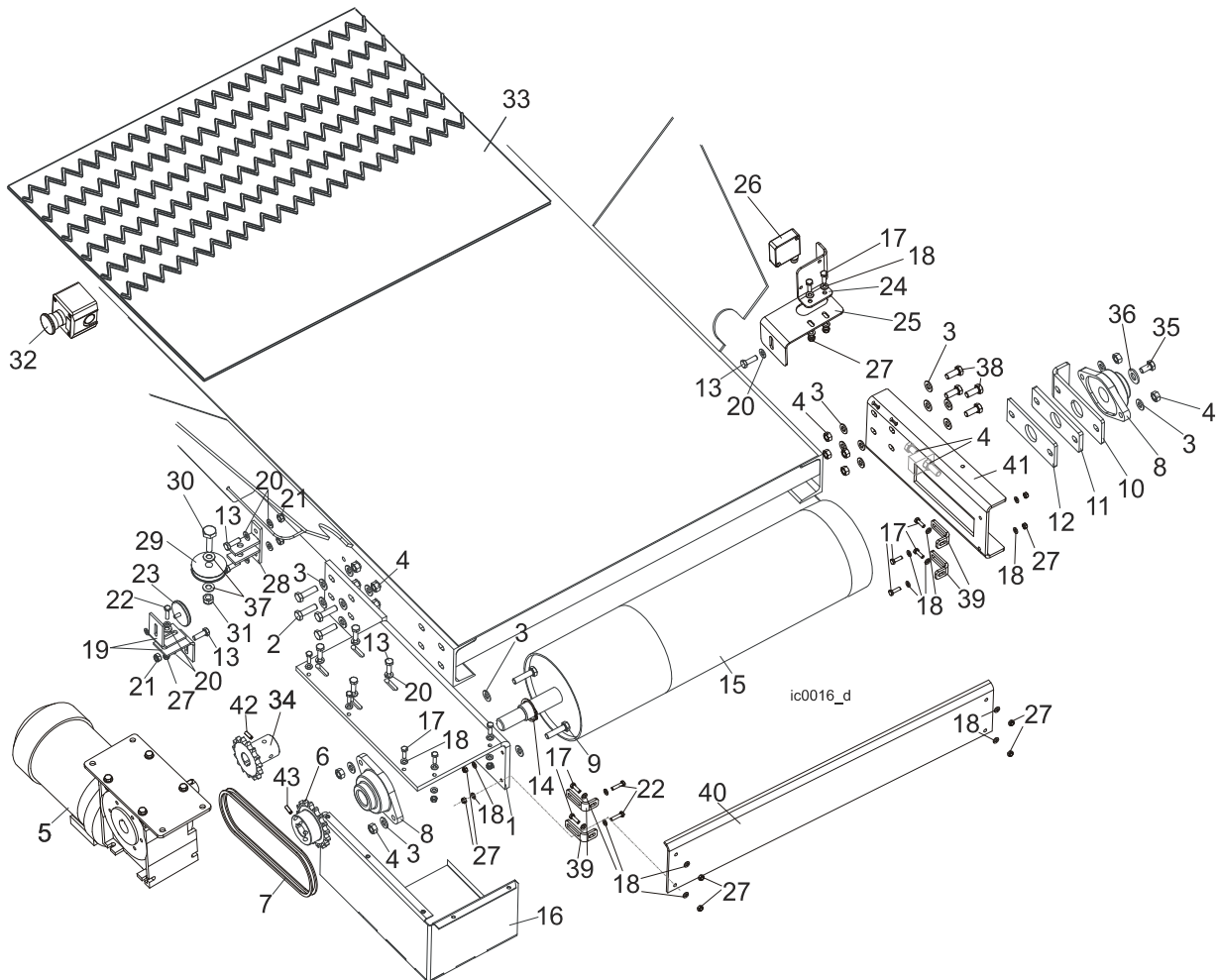

REF.	DESCRIPTION (◆ Indicates Parts Available In Assemblies Only)	PART #	QTY
1	BRACKET, IC GEAR BOX MOUNT	090848-1	1
2	BOLT, M10x35-8.8 HEX HEAD FULL THREAD ZINC	F81003-17	4
3	WASHER, 10.5 ZINC FLAT	F81055-1	18
4	NUT, M10-8-B ZINC HEX	F81033-3	14
5	MOTOREDUCER W/PLATE COMPLETE	503079	1
	GEAR BOX, MR63/10/1.5-1400K3/N+S/B3	504859	1
	MOTOR, Skh-80X-4D1	095064	1
	REDUCER, MR63/10/DS-160/19-WJ1/B3	083806	1
	PLATE, MOTOREDUCER WITH CB3	503078-1	1
	BOLT, M8x30-5.8 HEX HEAD FULL THREAD ZINC	F81002-2	4
	NUT, M8-8-B HEX NYLON ZINC LOCK	F81032-2	4
	WASHER, 8.4 FLAT ZINC	F81054-1	8

5 Replacement Parts

Motor & Drive Roller

6	SPROCKET, 10B Z15	092956-1	2	
7	CHAIN, 10B-52PZ TRANSMISSION ROLLER	092957	1	
8	BEARING, UCFL 206 CX BALL	090851	2	
9	BOLT, M10x40-8.8 HEX HEAD FULL THREAD ZINC	F81003-16	4	
10	BRACKET, CONVEYOR BELT TENSIONER	090914-1	1	
11	PLATE, CONVEYOR BELT TENSIONER	090852-1	1	
12	PLATE, CONVEYOR BELT TENSIONER	090854-1	1	
13	BOLT, M8X25-8.8-B HEX HEAD FULL THREAD ZINC	F81002-5	10	
14	RING, Z30 SPRING RETAINING	F81090-23	1	
15	PULLEY, DRIVE SIDE	090846	1	
16	GUARD, IC MOTOREDUCER	095167-1	1	
17	BOLT, M6X20-8.8 HEX HEAD FULL THREAD ZINC	F81001-2	13	
18	WASHER, 6.4 ZINC FLAT	F81053-1	28	
19	BRACKET, PHOTO SENSOR RECEIVER MOUNT	091405	2	
20	WASHER, 8.4 ZINC FLAT	F81054-1	4	
21	NUT, M8-8-B HEX NYLON ZINC LOCK	F81032-2	6	
22	BOLT, M6x25-5.8 HEX HEAD FULL THREAD ZINC	F81001-3	3	
23	SENSOR, PHOTO RECEIVER	091401	1	
24	PLATE, PHOTO SENSOR TRANSMITTER MOUNT	093991-1	1	
25	BRACKET, PHOTO SENSOR TRANSMITTER	094646-1	1	
26	SENSOR, XUK1APANM12 PHOTO TRANSMITTER	093169	1	
27	NUT, M6-8-B HEX NYLON ZINC LOCK	F81031-2	11	
28	BRACKET, CABLE GUIDE PULLEY MOUNT	091787-1	2	
29	PULLEY, CABLE GUIDE	091273-1	2	
30	BOLT, M12X55-8.8 HEX HEAD ZINC	F81004-12	2	
31	NUT, M10-8-B HEX NYLON ZINC LOCK	F81033-1	3	
32	SWITCH, EMERGENCY XALJ174F	E22703-P	2	
33	BELT, 2M0P3LG 11400X730 INCLINE CONVEYOR	090847	1	
34	SPROCKET, 10B Z15	095162	1	
35	BOLT, M10X16-8.8	F81003-13	1	
36	WASHER, ZINC	088059-1	1	
37	WASHER, 13 FLAT ZINC	F81056-1	4	
38	BOLT, M10x25-8.8 HEX HEAD FULL THREAD ZINC	F81003-11	4	
39	BRACKET, COVER 2 - PTD	092419-1	4	
40	COVER, CONVEYOR BELT-PTD	092423-1	1	
41	TENSIONER, BELT 3	090913-1	1	
	ROLLER COVERING, 50M.	R00100	10.5m	
	ADHESIVE, "TEXCOL" 1KG PACKAGE	090875	1kg	
42	SCREW M6X8	F81013-1	1	
43	SCREW, SET,M8x8-33H FE/ZN HEX SCKT HEAD	F81014-1	1	

5.3 Legs

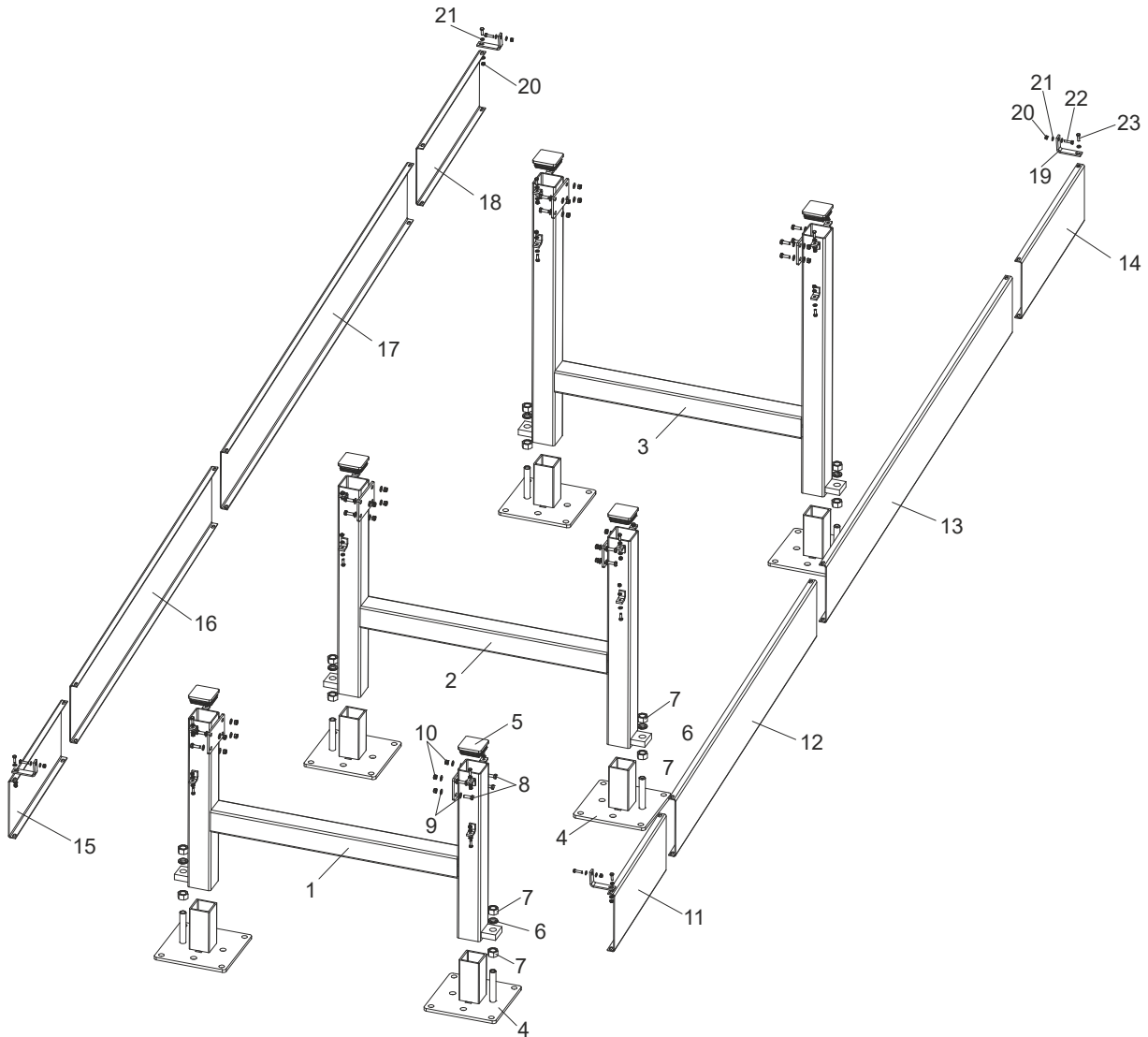

REF.	DESCRIPTION (◆ Indicates Parts Available In Assemblies Only)	PART #	QTY
	LEG ASSEMBLY, INCLINE CONVEYOR SHORT	507693	1
1	Leg Weldment, IC Short - Upper Part	507694-1	1
	LEG ASSEMBLY, INCLINE CONVEYOR MIDDLE	507695	1
2	Leg Weldment, IC Middle - Upper Part	507696-1	1
	LEG ASSEMBLY, INCLINE CONVEYOR LONG	507697	1
3	Leg Weldment, IC Long - Upper Part	507698-1	1
4	LEG WELDMENT, IC - LOWER PART	512225-1	6
5	CAP, #199247 TUBE END	089644	6
6	WASHER, 20.5 ZINC SPLIT LOCK	F81059-1	6

5 Replacement Parts

Legs

7	NUT, M20-8 ZINC HEX	F81037-1	12	
8	BOLT, M8X25-8.8-B HEX HEAD FULL THREAD ZINC	F81002-5	24	
9	WASHER, 8.4 ZINC FLAT	F81054-1	48	
10	NUT, M8-8-B ZINC HEX	F81032-2	24	
11	COVER, CONVEYOR BELT 6 -PTD	507706-1	1	
12	COVER, CONVEYOR BELT 5 -PTD	507702-1	1	
13	COVER, CONVEYOR BELT1 4 -PTD	507699-1	1	
14	COVER, CONVEYOR BELT 8	507704-1	1	
15	COVER, CONVEYOR BELT 3 -PTD	507707-1	1	
16	COVER, CONVEYOR BELT - PTD	507703-1	1	
17	COVER, CONVEYOR BELT 6 -PTD	507701-1	1	
18	COVER, CONVEYOR BELT 7	507705-1	1	
19	BRACKET, GUARD NO.1	092418-1	4	
20	NUT,M6-8-B HEX,NYLON LOCK ZINC	F81031-2	8	
21	WASHER, M6, FLAT,ZINC	F81053-1	16	
22	BOLT, M6X25MM,HEX HEAD,GR 8.8,ZINC	F81001-3	4	
23	BOLT, M6X20MM, HH, FULL THREAD, ZINC	F81001-2	4	

5.4 Decals

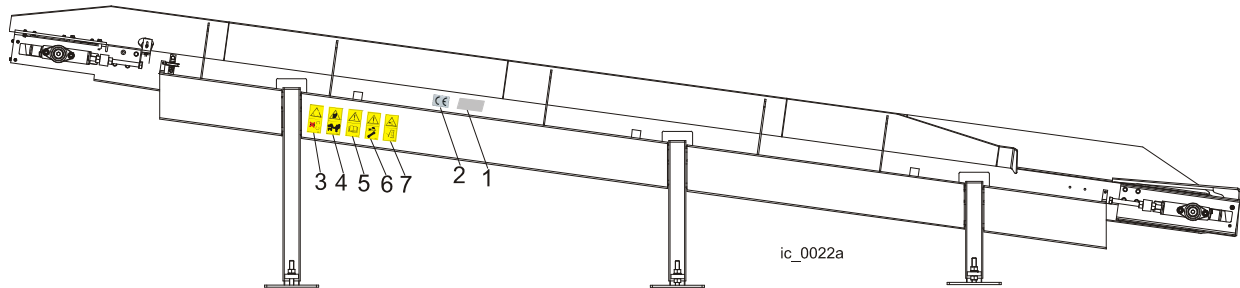

REF.	DESCRIPTION (◆ Indicates Parts Available In Assemblies Only)	PART #	QTY
1	DECAL, SERIAL NUMBER	-----	1
	DECALS KIT, IC	503670	1
2	Decal, CE Certified Ssawmill	P85070	1
3	Decal, Gear Caution	099540	1
4	Decal, Keep a Safe Distance Away	099221	1
5	Decal, Read the Operator's Manual	096317	1
6	Decal, Disconnect Power Supply Before Servicing	098177	1
7	Decal, Close All Guards and Covers Before Starting the Machine	099220	1

5 Replacement Parts

Decals

5.5 CB3-WB Incline Conveyor

CB3-WB_001
 CB3-WB_MANUAL

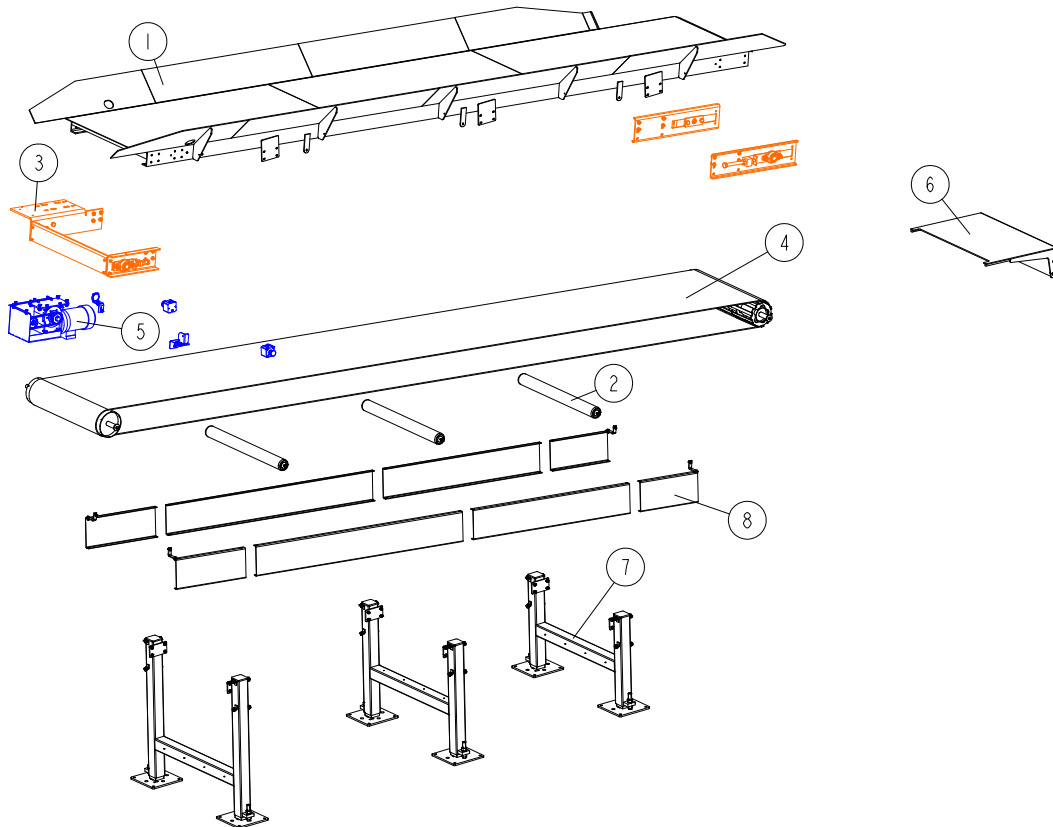

REF	DESCRIPTION (* indicates parts available in assemblies only)	PART #	QTY
-	CB3-WB INCLINE CONVEYOR	CB3-WB	1
1	BASE, INCLINE CONVEYOR	090833-1	1
2	ROLLER SET, CB3 See Section 5.6	515853	1
3	PULLEY SUPPORT KIT See Section 5.7	515854	1
4	BELT KIT WITH ROLLERS, CB3 See Section 5.8	515855	1
5	MOTOR KIT, CB3 See Section 5.9	515856-WB	1
6	COVER, INCLINE CONVEYOR See Section 5.10	515857	1
7	LEG SET, CB3-2000 See Section 5.11	521644	1
8	COVER SET, CB3-2000 See Section 5.12	521645	1

5 Replacement Parts

Roller Set, CB3

5.6 Roller Set, CB3

515853_001_A
CB3-WB_MANUAL

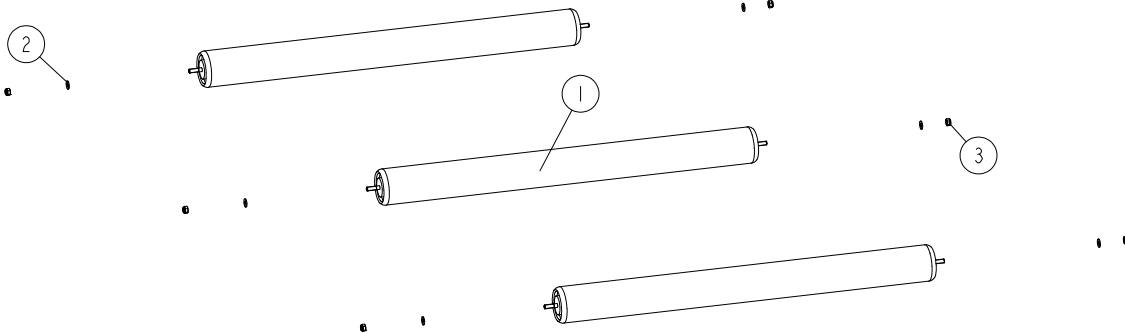

REF	DESCRIPTION (* indicates parts available in assemblies only)	PART #	QTY	
-	ROLLER SET, CB3	515853	1	
1	ROLLER, 76MM DIAMETER	090843-1	3	
2	WASHER, 8.4 FLAT ZINC	F81054-1	6	
3	NUT, M8-8-B HEX NYLON ZINC LOCK	F81032-2	6	

5.7 Pulley Support Kit

515854_001_A
CB3-WB_MANUAL

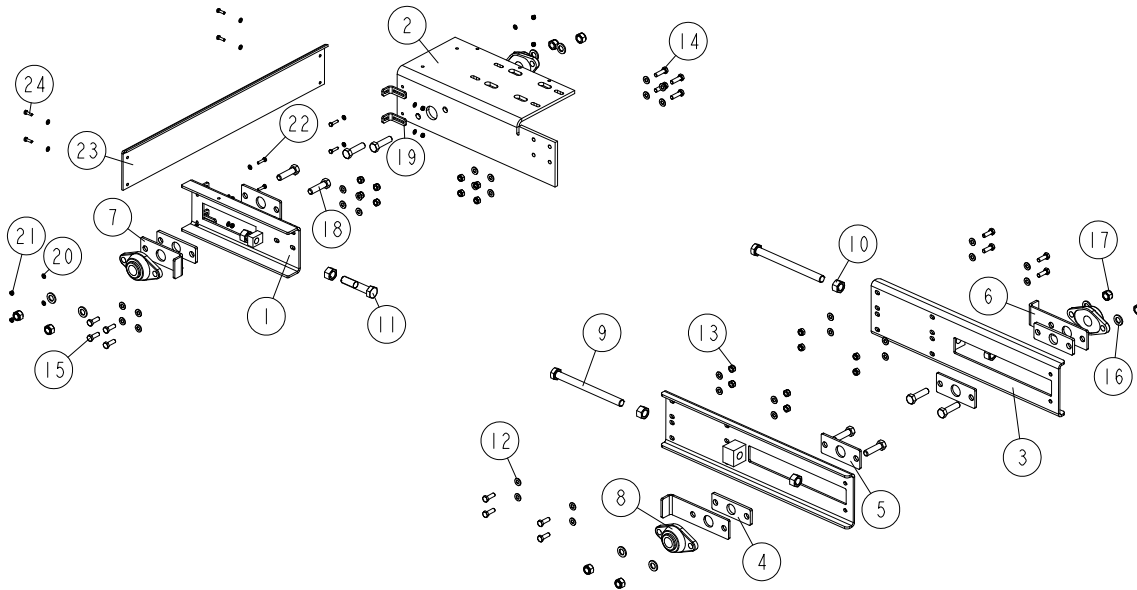

REF	DESCRIPTION (* indicates parts available in assemblies only)	PART #	QTY
-	PULLEY SUPPORT KIT	515854	1
1	TENSIONER, BELT 3	090913-1	1
2	SUPPORT, GEAR BOX INCLINE CONVEYOR - PAINTED	095164-1	1
3	TENSIONER, BELT	505831-1	2
4	PLATE, CONVEYOR BELT TENSIONER	090852-1	3
5	PLATE, CONVEYOR BELT TENSIONER	090854-1	3
6	BRACKET, CONVEYOR BELT TENSIONER	090853-1	2
7	BRACKET, CONVEYOR BELT TENSIONER	090914-1	1
8	BEARING, FYTB30FJ BALL (SKF)	090851	4
9	BOLT, M20X240-8.8 HEX HEAD FULL THREAD ZINC	F81007-1	2
10	NUT, M20-8-FE/ZN5 PN-86/M-82144	F81037-1	6
11	BOLT, M20X100-8.8 HEX HEAD FULL THREAD ZINC	F81007-13	1
12	WASHER, 10.5 FLAT ZINC	F81055-1	32
13	NUT, M10-8-B HEX NYLON ZINC LOCK	F81033-1	16
14	BOLT, M10X35-8.8 HEX HEAD FULL THREAD ZINC	F81003-17	4
15	BOLT, M10X30-5.8 HEX HEAD FULL THREAD ZINC	F81003-2	12
16	WASHER, 17 SPLIT LOCK ZINC	F81058-1	8
17	NUT, M16-8-HEX NYLON ZINC LOCK	F81036-2	8
18	BOLT, M16 X 60 8.8 FE/ZN5 HEX HEAD FULL	F81006-12	8
19	BRACKET, COVER 2 - PTD	092419-1	4

5 Replacement Parts

Pulley Support Kit

REF	DESCRIPTION (* indicates parts available in assemblies only)	PART #	QTY	
20	WASHER, 6.4 FLAT ZINC	F81053-1	16	
21	NUT, M6-8-B HEX NYLON ZINC LOCK	F81031-2	8	
22	BOLT, M6X25-5.8 HEX HEAD FULL THREAD ZINC	F81001-3	4	
23	COVER, CONVEYOR BELT-PTD	092423-1	1	
24	BOLT, M6X20 8.8 HEX HEAD FULL THREAD ZINC	F81001-2	4	

5.8 Belt Kit with Rollers, CB3

515855_001
CB3-WB_MANUAL

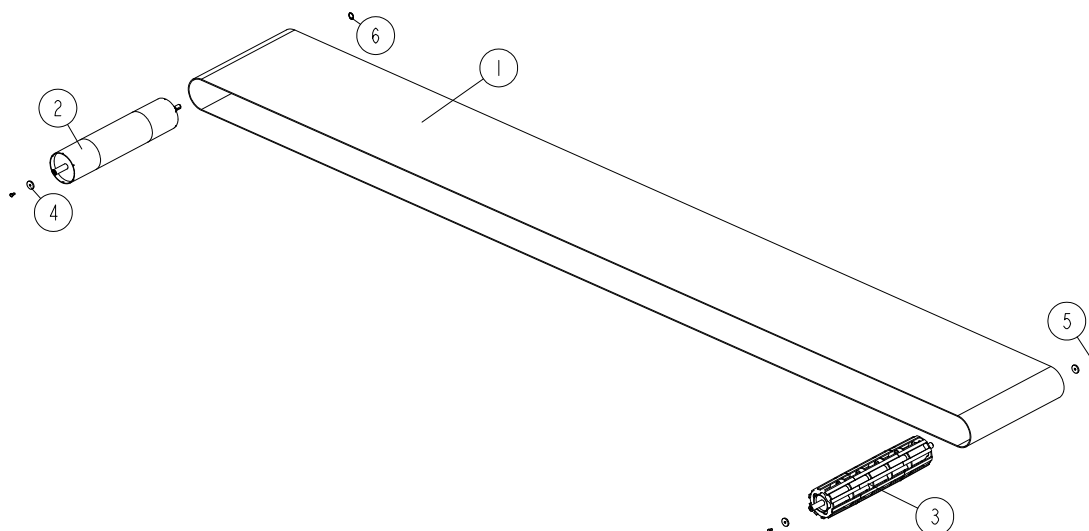

REF	DESCRIPTION (* indicates parts available in assemblies only)	PART #	QTY	
-	BELT KIT WITH ROLLERS, CB3	515855	1	
1	BELT, 2M0P3LG 11400X730 INCLINE CONVEYOR	090847	1	
-	PULLEY W/ADHESIVE & TAPE	093598	1	
2	PULLEY 1, INCLINE CONVEYOR - PAINTED	090846-1	1	
3	PULLEY, IDLE SIDE	092970-1	1	
4	WASHER, 10.5/45-6 ZINC-PLATED	086286-1	3	
5	BOLT, M10X16-8.8 HEX HEAD FULL THREAD ZI	F81003-13	3	
6	RING, Z30 SPRING RETAINING	F81090-23	1	

5 Replacement Parts

Motor Kit, CB3

5.9 Motor Kit, CB3

515856-WB_001
CB3-WB_MANUAL

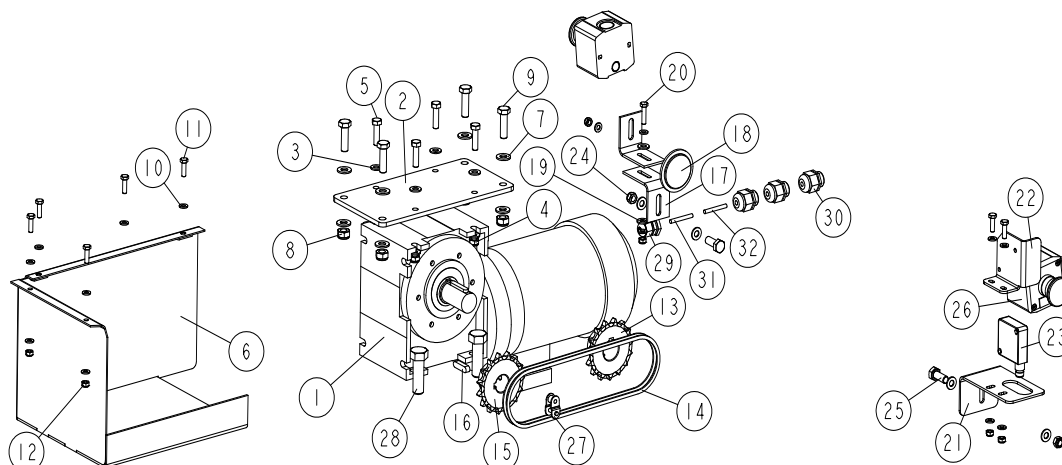

REF	DESCRIPTION (* indicates parts available in assemblies only)	PART #	QTY
-	MOTOR KIT, CB3	515856-WB	1
-	MOTOREDUCER W/PLATE COMPLETE	503079	1
1	GEAR MOTOR MRA-06/10.D3/S+N/B3 "KACPEREK"	503077	1
2	PLATE, GEAR MOTOR WITH CB3	503078-1	1
3	WASHER, 8.4 FLAT ZINC	F81054-1	8
4	NUT, M8-8-B HEX NYLON ZINC LOCK	F81032-2	4
5	BOLT, M8X30-5.8-B HEX HEAD FULL THREAD ZINC	F81002-2	4
6	GUARD, IC MOTOREDUCER	095167-1	1
7	WASHER, 10.5 FLAT ZINC	F81055-1	8
8	NUT, M10-8-B HEX NYLON ZINC LOCK	F81033-1	4
9	BOLT, M10X35-8.8 HEX HEAD FULL THREAD ZINC	F81003-17	4
10	WASHER, 6.4 FLAT ZINC	F81053-1	14
11	BOLT, M6X20 8.8 HEX HEAD FULL THREAD ZINC	F81001-2	7
12	NUT, M6-8-B HEX NYLON ZINC LOCK	F81031-2	6
13	SPROCKET, 10B Z 15 INCLINE CONVEYOR	095162	1
14	CHAIN, 10B-35PZ PN77/M-84168 ROLLER	092957	1
15	SPROCKET, 10B Z15	092956-1	1
16	KEY, A8X7X32 PARALLEL	088564	1
17	BRACKET, PHOTO SENSOR RECEIVER MOUNT PTD	091405-1	2
18	REFLECTOR	091401	1
19	WASHER, 8.4 FLAT ZINC	F81054-1	6
20	BOLT, M6X25-5.8 HEX HEAD FULL THREAD ZIN	F81001-3	1
21	BRACKET, PHOTO SENSOR TRANSMITTER	094646-1	1

REF	DESCRIPTION (* indicates parts available in assemblies only)	PART #	QTY	
22	PLATE, PHOTO SENSOR TRANSMITTER MOUNT	093991-1	1	
23	SENSOR, XUK1APANM12 PHOTOELECTRIC	093169	1	
24	NUT, M8-8-B HEX NYLON ZINC LOCK	F81032-2	2	
25	BOLT, M10X25 8.8 HEX HEAD FULL THREAD ZI	F81003-11	2	
26	BUTTON, XALK 178 EMERGENCY STOP 8	E22703-P	2	
27	LINK, REDUCER LP4 R1-15,875X9,65	089405	1	
28	BOLT, M16 X 50-8.8 HEX HEAD FULL THREAD	F81006-7	2	
29	GLAND, DP9/H CABLE	F81096-2	1	
30	GLAND, DP 13/H CABLE	F81096-4	3	
31	CABLE, OLFLEX 400P 2X1	R80583-5	1	
32	CABLE, OLFLEX CLASIC 400P 4G2,5	R80585-6	1	

5 Replacement Parts

Cover, Incline Conveyor

5.10 Cover, Incline Conveyor

515857_001
CB3-WB_MANUAL

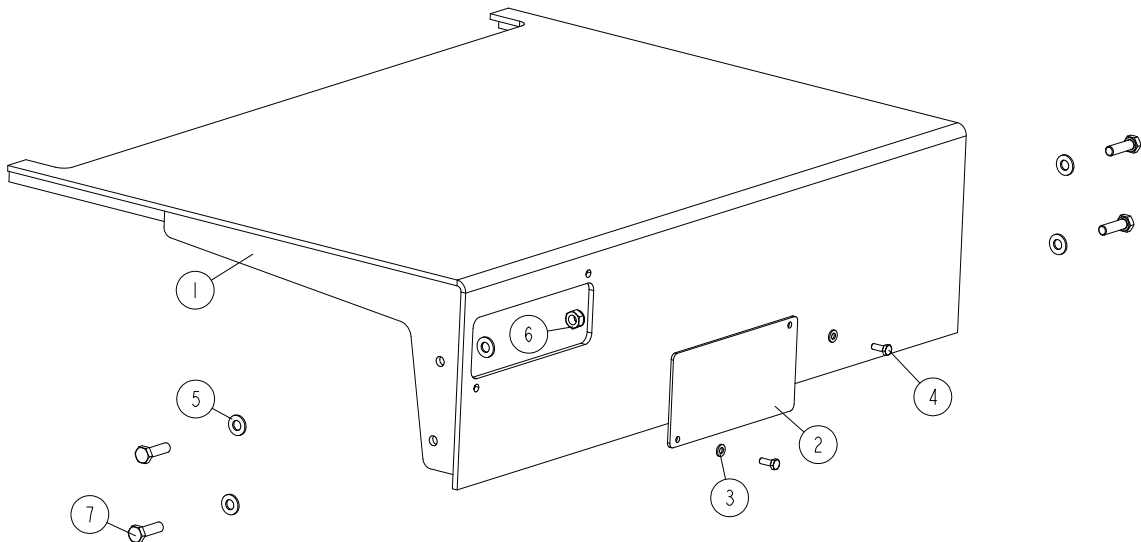

REF	DESCRIPTION (* indicates parts available in assemblies only)	PART #	QTY	
-	COVER, INCLINE CONVEYOR	515857	1	
1	COVER, CONVEYOR BELT WELDMENT	096692-1	1	
2	PLATE, CB3 COVER	511114-1	1	
3	WASHER, 6.4 FLAT ZINC	F81053-1	2	
4	BOLT, M6X16-5.8 HEX HEAD FULL THREAD ZINC	F81001-15	2	
5	WASHER, 10.5 FLAT ZINC	F81055-1	8	
6	NUT, M10-8-B HEX NYLON ZINC LOCK	F81033-1	4	
7	BOLT, M10X35-8.8 HEX HEAD FULL THREAD ZINC	F81003-17	4	

5.11 Leg Set, CB3-2000

521644_001
CB3-WB_MANUAL

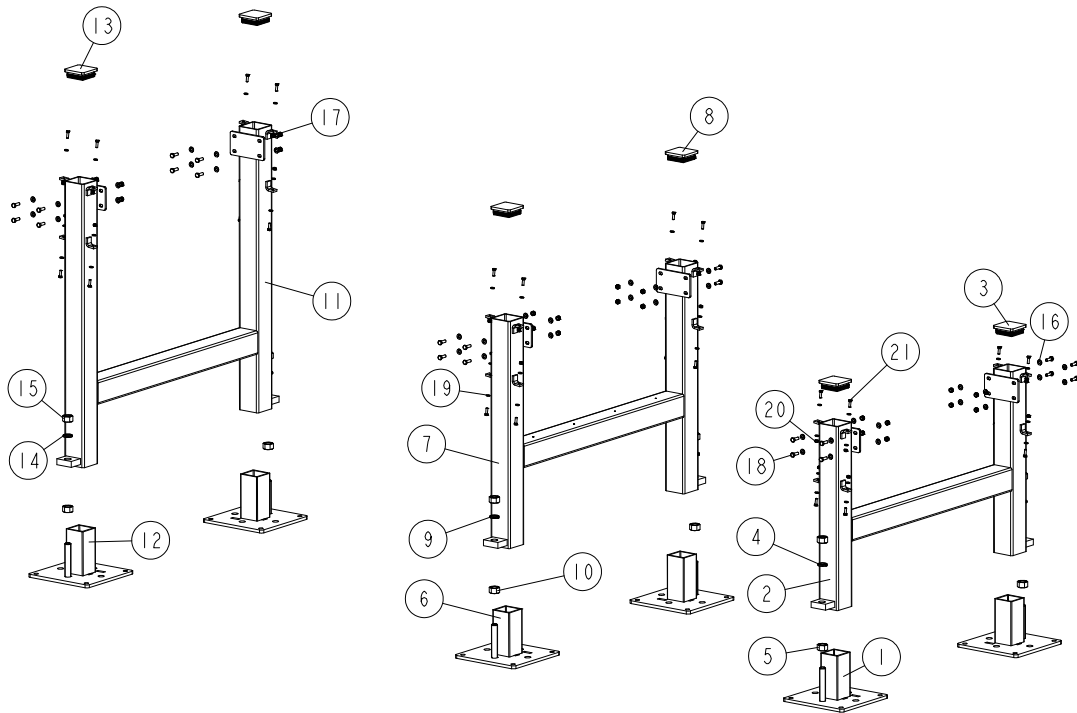

REF	DESCRIPTION (* indicates parts available in assemblies only)	PART #	QTY
-	LEG SET, CB3-2000	521644	1
-	LEG ASSEMBLY, INCLINE CONVEYOR SHORT	507693	1
1	FOOT PLATE ASSEMBLY	512225-1	2
2	LEG WELDMENT, IC SHORT - UPPER PART	507694-1	1
3	CAP, 80X80 GR 2-4 #111227 TUBE END	089644	2
4	WASHER, 20.5 SPLIT LOCK ZINC	F81059-1	2
5	NUT, M20-8- FE/ZN5 PN-86/M-82144	F81037-1	4
-	LEG ASSEMBLY, INCLINE CONVEYOR MIDDLE	507695	1
6	FOOT PLATE ASSEMBLY	512225-1	2
7	LEG WELDMENT, IC MIDDLE - UPPER PART	507696-1	1
8	CAP, 80X80 GR 2-4 #111227 TUBE END	089644	2
9	WASHER, 20.5 SPLIT LOCK ZINC	F81059-1	2
10	NUT, M20-8- FE/ZN5 PN-86/M-82144	F81037-1	4
-	LEG ASSEMBLY, INCLINE CONVEYOR LONG	507697	1
11	LEG WELDMENT, IC LONG - UPPER PART	507698-1	1
12	FOOT PLATE ASSEMBLY	512225-1	2
13	CAP, 80X80 GR 2-4 #111227 TUBE END	089644	2

5 Replacement Parts

Leg Set, CB3-2000

REF	DESCRIPTION (* indicates parts available in assemblies only)	PART #	QTY	
14	WASHER, 20.5 SPLIT LOCK ZINC	F81059-1	2	
15	NUT, M20-8- FE/ZN5 PN-86/M-82144	F81037-1	4	
16	WASHER, 8.4 FLAT ZINC	F81054-1	48	
17	NUT, M8-8-B HEX NYLON ZINC LOCK	F81032-2	24	
18	BOLT, M8X25-8.8-B HEX HEAD FULL THREAD ZINC	F81002-5	24	
19	WASHER, 6.4 FLAT ZINC	F81053-1	48	
20	NUT, M6-8-B HEX NYLON ZINC LOCK	F81031-2	24	
21	BOLT, M6X20 8.8 HEX HEAD FULL THREAD ZINC	F81001-2	24	

5.12 Cover Set, CB3-2000

521645_001
CB3-WB_MANUAL

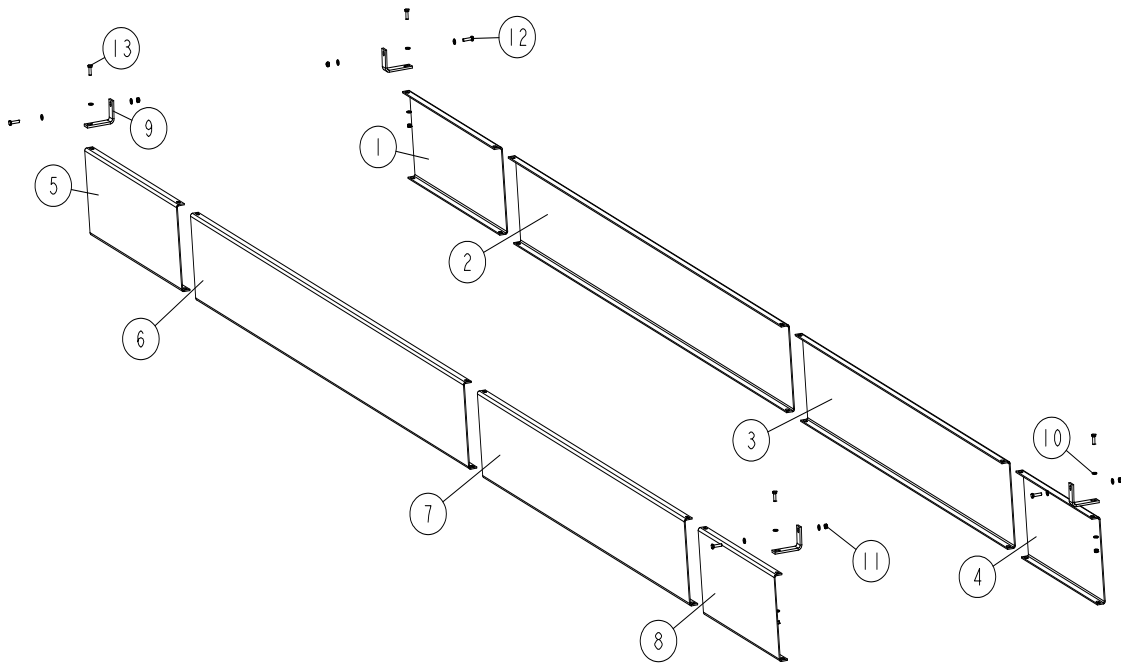

REF	DESCRIPTION (* indicates parts available in assemblies only)	PART #	QTY
-	COVER SET, CB3-2000	521645	1
1	COVER, CONVEYOR BELT 8	507704-1	1
2	COVER, CONVEYOR BELT 1 4 -PTD	507699-1	1
3	COVER, CONVEYOR BELT 5 -PTD	507702-1	1
4	COVER, CONVEYOR BELT 6 -PTD	507706-1	1
5	COVER, CONVEYOR BELT 7	507705-1	1
6	COVER, CONVEYOR BELT 6 -PTD	507701-1	1
7	COVER, CONVEYOR BELT - PTD	507703-1	1
8	COVER, CONVEYOR BELT 3 -PTD	507707-1	1
9	BRACKET, GUARD NO.1	092418-1	4
10	WASHER, 6.4 FLAT ZINC	F81053-1	16
11	NUT, M6-8-B HEX NYLON ZINC LOCK	F81031-2	8
12	BOLT, M6X25-5.8 HEX HEAD FULL THREAD ZINC	F81001-3	4
13	BOLT, M6X20 8.8 HEX HEAD FULL THREAD ZINC	F81001-2	4

EC declaration of conformity according to EC Machinery Directive 2006/42/EC, Annex II, 1.A

Manufacturer:

Wood-Mizer Industries sp. z o.o.
Nagórna 114, 62-600 Koło; Poland
Tel. +48 63 26 26 000

This declaration of conformity is issued under the sole responsibility of the manufacturer.

Following machine in our delivered version complies with the appropriate essential safety and health requirements of the EC Machinery Directive 2006/42/EC based on its design and type, as brought into circulation by us. In case of alteration of the machine, not agreed by us, this declaration is no longer valid.

We, the undersigned herewith declare, that:

Designation of the machine: **Belt Conveyor**
TYPE: CB3
No. of manufacturer: CB3/001/2015

**Is in conformity with the following
EC directives:**

EC Machinery Directive 2006/42/EC
EC Electromagnetic Compatibility Directive
2014/30/EU

**And is in conformity with the following
Harmonized Standards:**

PN-EN ISO 12100:2012;
PN-EN ISO 14120:2016-03 ;
PN-EN 349+A1:2010 ;
PN-EN ISO 13849-1:2016-02;
PN-EN 60204-1:2010;
PN-EN ISO 13857:2010;

Responsible for Technical Documentation: Piotr Adamiec / Engineering Manager
Wood-Mizer Industries Sp. z o.o.
62-600 Koło, ul. Nagórna 114, Poland
Tel. +48 63 26 26 000

Place/Date/Authorized Signature:

Koło, 21.04.2015



Title :

Engineering Manager

