

# **D10 Engine**

## **Safety, Operation, Maintenance & Parts Manual**

---

**LT15**

**rev. C2.05**

---



**Safety is our #1 concern!** Read and understand all safety information and instructions before operating, setting up or maintaining this machine.

*February 1998*

*Form #1098*

# Table of Contents

# Section-Page

	<b>ABOUT THIS MANUAL</b>	<b>III</b>
<b>SECTION 1</b>	<b>OPERATION</b>	<b>1-1</b>
1.1	Preparation For Starting .....	1-2
1.2	Starting The Engine .....	1-5
1.3	Stopping The Engine .....	1-11
<b>SECTION 2</b>	<b>MAINTENANCE</b>	<b>2-1</b>
2.1	Air Cooling System .....	2-1
2.2	Air Filter & Pre-Cleaner .....	2-2
2.3	Oil & Oil Filter .....	2-3
2.4	Fuel Filter .....	2-4
2.5	Drive Belt Adjustment.....	2-5
2.6	RPM Adjustments .....	2-7
<b>SECTION 3</b>	<b>REPLACEMENT PARTS</b>	<b>3-1</b>
3.1	How To Use The Parts List .....	3-1
3.2	Sample Assembly .....	3-1
3.3	Engine Assembly .....	3-2
3.4	Brake/Belt Tensioner Assembly.....	3-4
3.5	Key Switch Mount Bracket .....	3-7
<b>SECTION 4</b>	<b>ELECTRICAL INFORMATION</b>	<b>4-1</b>
4.1	Electrical Wiring Diagram, LT15D10+SW08 .....	4-1
4.2	Electrical Components, LT15D10.....	4-2

## ABOUT THIS MANUAL

This manual is provided as a supplement to the equipment manufacturer's manuals. This manual provides information specific to the use of this equipment on the Wood-Mizer® sawmill. Refer to the sawmill operator's manual and manufacturer's manual before attempting to operate this equipment.



**IMPORTANT!** Read the sawmill operator's manual and engine manufacturer's manual for instructions and safety precautions before operating this equipment.

The information and instructions given in this manual do not amend or extend the limited warranties for the equipment given at the time of purchase.

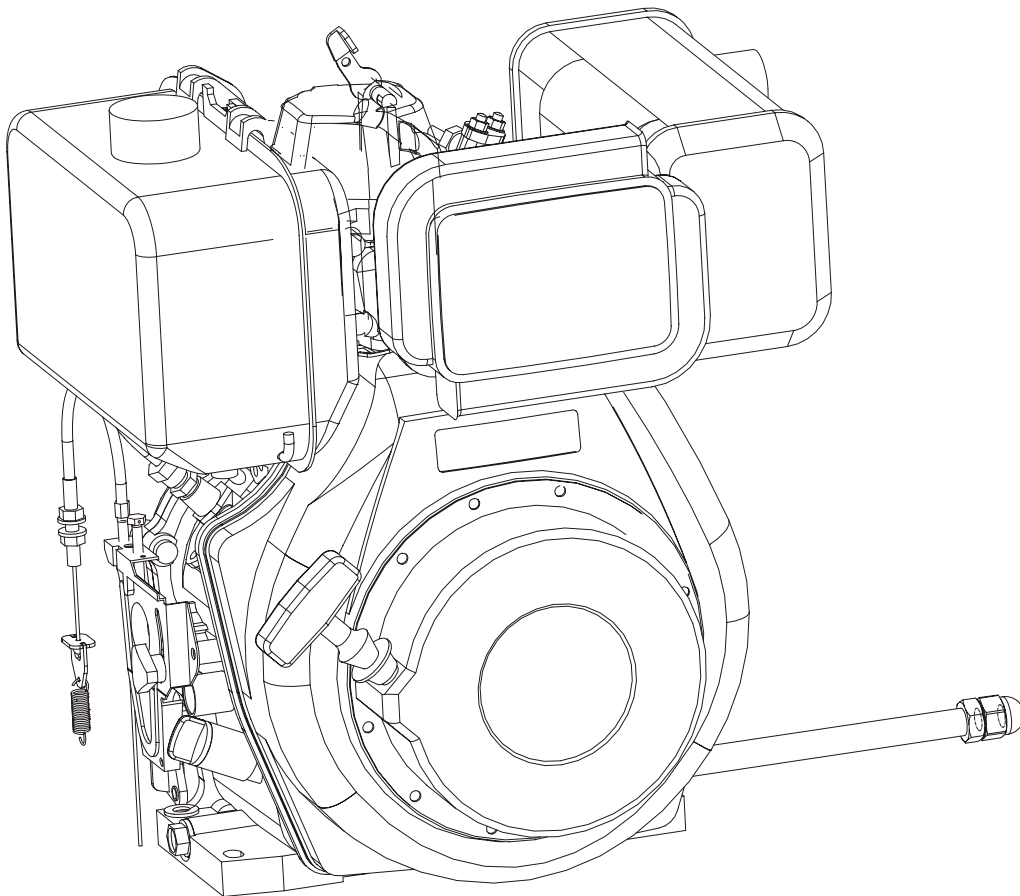

## SECTION 1 OPERATION

While your engine is still new, applying heavy loads may reduce its life. Follow the breaking-in procedure below during the first 20 hours of operation.

### 1. Avoid overloading

Never apply heavy loads during the breaking-in period.

### 2. Change engine oil regularly

Change the engine oil after the first 50 hours of operation or after the first month (whichever comes first) and every 3 months or 200 hours thereafter.



**DANGER!** Always drain the oil while the engine is still warm. It may be difficult to drain the oil completely when the engine is cold.

### 3. Check the fuel level in the fuel indicator pipe. Do not allow the fuel tank to become empty. If this should happen, perform the following steps:

- a) Fill the tank with diesel fuel,
- b) Unbolt the fuel tank mounting bolts,
- c) Raise the fuel tank so that fuel flows into the solenoid valve and air bleeds from the system,
- d) Tighten the tank mounting bolts and attempt to start the engine,
- e) If the starting attempts are not successful, repeat steps b-d.

## 1.1 Preparation For Starting

### 1. Fuel Selection And Handling

Use only diesel fuel recommended by the manufacturer. Before filling the fuel tank, make sure the fuel does not contain water and/or dust. Failure to do so may result in damage to the fuel injection pump and nozzles.



**CAUTION!** Use only recommended diesel fuel. Failure to do so may result in serious engine damage.

**CAUTION!** The cetane value of the diesel fuel should be above 45. This will ensure easy engine start and will prevent misfiring and white exhaust gases.

**CAUTION!** Diesel fuel substitutes are not recommended; they may cause damage to the fuel system.

**CAUTION!** The fuel should be free of water and dust. Damage to the fuel injection pump and nozzles may result.

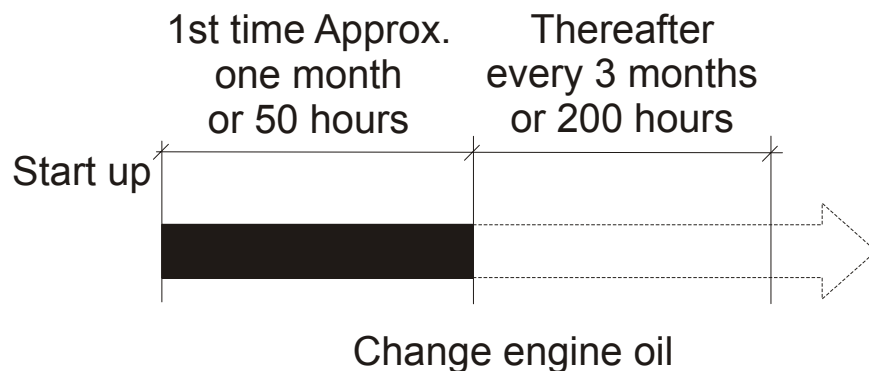

# 1 OPERATION

## Preparation For Starting

---

Overfilling is very dangerous. Do not fill the tank beyond the top of the red plug inside the fuel tank filter.

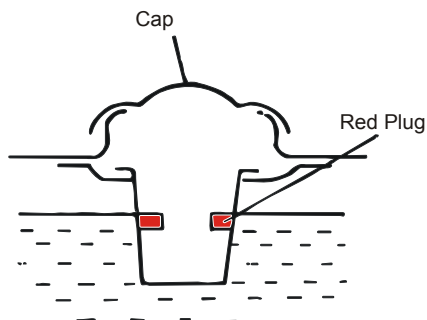

Fuel tank capacity: 4,7 l.

## 2. Engine Oil

**WARNING!** Always check the engine oil level before starting the engine. Add oil if necessary. If the lubricating oil level is too low, it may result in engine damage. If it is too high, a sudden increase of RPM can occur as a result of the lube oil combustion.

Use 5W/40 engine oil.

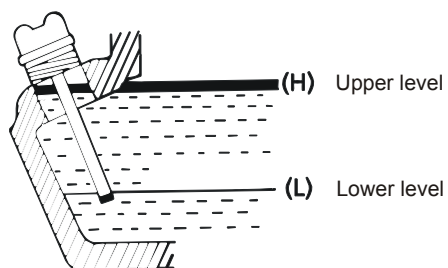

Pour the oil up to the mouth of the filler port. Make sure the engine is level when pouring the oil.

Lube oil capacity: 1.65 l.

### 3. Servicing The Air Cleaner

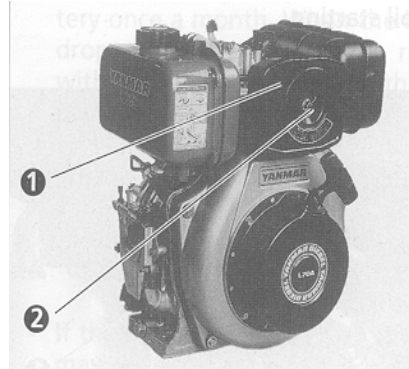

1 - Air cleaner, 2 - Wing nut

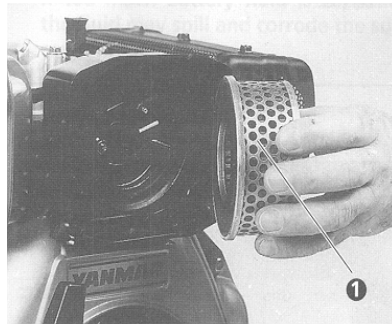

1 - Element



**CAUTION!** Do not clean the air cleaner element with detergents as it is of an oil-soaked type.

**CAUTION!** Replace the element when the power output decreases or a bad color of the exhaust gases is noticed.

**CAUTION!** Never run the engine without the air cleaner element. Doing so may result in quick engine wear.

# 1 OPERATION

*Starting The Engine*

---

## 1.2 Starting The Engine

### Recoil Starting

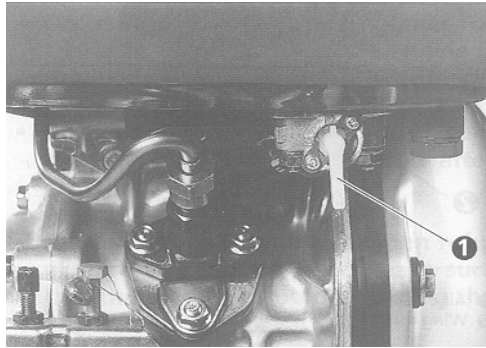

1 - Fuel cock

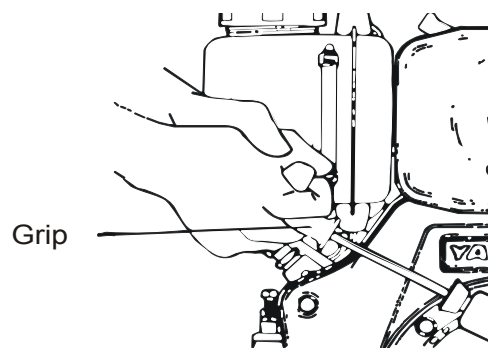

**Perform the following steps to start the engine:**

1. Set the fuel cock in the open ("O") position.
2. Put the engine speed lever in the "START" position.



3. Pull out the start rope.

a) Holding the rope handle, pull the rope until you feel strong resistance and then allow the handle to return to its initial position.

b) Push the decompression lever down. It will return automatically to its original position when the start rope is pulled again.

c) Pull out the start rope briskly holding the handle with both hands.



**CAUTION!** Do not allow the start rope handle to rapidly return to its original position. Release it gently to avoid damage to the starter.

**CAUTION!** Always pull the start rope **firmly** to start the engine.



**WARNING!** Never use any cold-starting aids such as ether, gasoline, paint thinner or other volatile liquid or gas.

# 1 OPERATION

## Starting The Engine

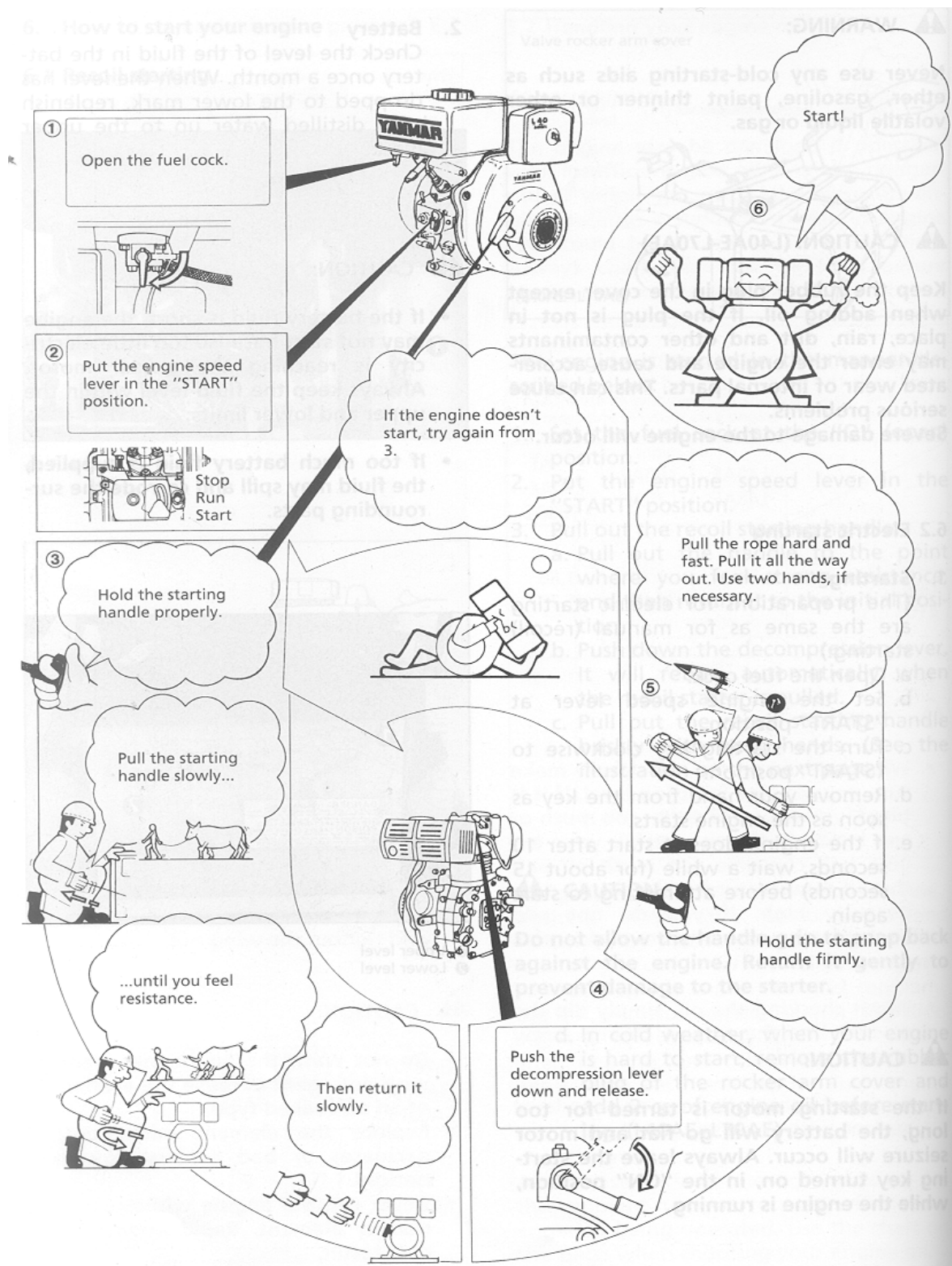

## Electric starting

### Engine Start

 **WARNING!** Do not start the engine when the tensioner lever is in the ENGAGED (up) position. Always be sure the blade is disengaged and all persons are away from the sawmill before starting the engine.

1. Set and lock with the pin the tensioner lever in the ENGINE START (middle) position.

See Figure 1-1.

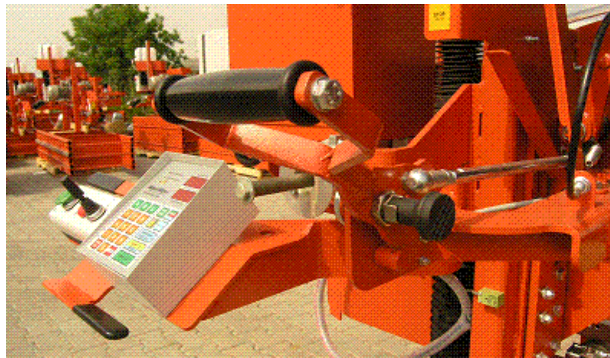

FIG. 1-1

2. Turn the key to the START position.

See Figure 1-2.



FIG. 1-2

# 1 OPERATION

## *Starting The Engine*

3. When the engine is started, release the tensioner lever to the IDLING (down) position.

See Figure 1-3.



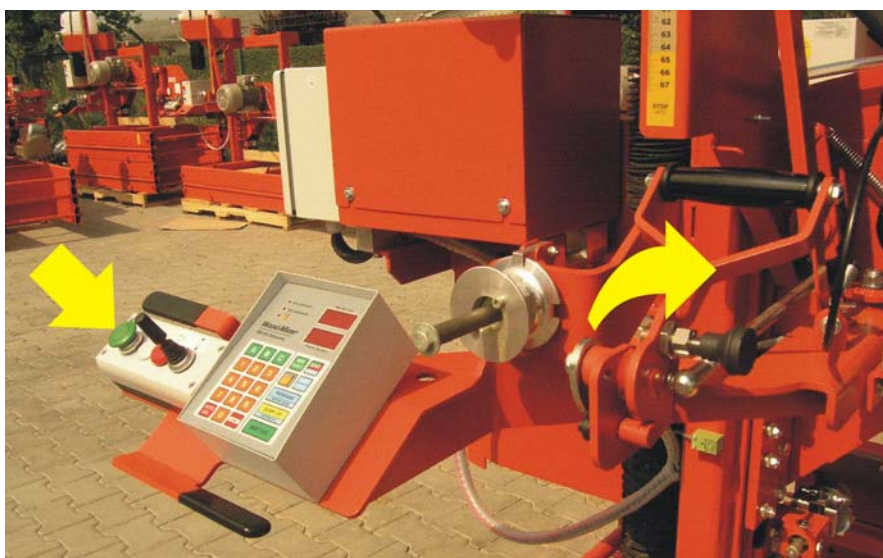

**FIG. 1-3**

4. To engage the blade, press and hold the green button on the control box and push the tensioner lever to the ENGAGED (up) position.



**FIG. 1-3**

 **CAUTION!** If the starter is on for too long time, the battery may go flat. Always keep the key in the “ON” position while the engine is running.

 **IMPORTANT!** The control light should be on when the key is in the ON position.

Warm up the engine without load for about 3 minutes.

 **CAUTION!** Do not loosen or readjust the throttle shut-off weldment bolt (idling adjustment lever). Damage to the engine may result.

 **WARNING!** The exhaust silencer is very hot during engine operation. Be careful not to touch the silencer.

**WARNING!** Never perform refueling while the engine is running.

## Battery

Check the level of the fluid in the battery once a month. When the level has dropped to the lower mark, replenish with distilled water up to the upper mark.

 **CAUTION!** If the battery fluid is short, the engine may not start because too little electricity is reaching the starter motor. Always keep the fluid level within the upper and lower limits.

**CAUTION!** If too much battery fluid is supplied, the fluid may spill and corrode the surrounding parts.

**CAUTION!** The light located on the key switch mount bracket is lit always when the key is turned to the “ON” position.

## 1.3 Stopping The Engine

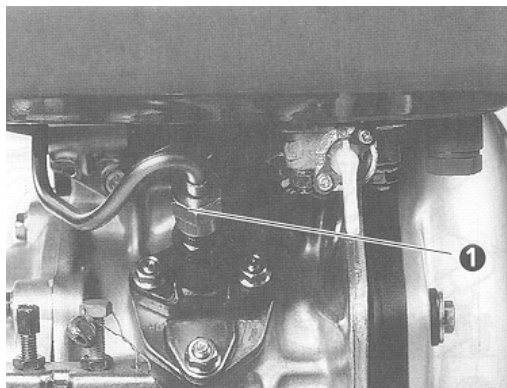

1 - Nut of high-pressure fuel pipe

1. Before stopping the engine, push the engine speed lever to the low-speed position and let the engine run for about 3 minutes with no load.
2. Return the engine speed lever to the “STOP” position.
3. In electric-start models, return the starter key to the “OFF” position.
4. Move the fuel cock lever to the “S” (closed) position.
5. Pull the start rope slowly until you feel resistance, i.e. until the engine is in the compression position (where the intake and exhaust valves are closed) and leave the engine in this position. This prevents rusting while the engine is not in use.

 **WARNING!** If the engine keeps on running even after the speed lever is placed in the “STOP” position, stop the engine either by closing the fuel cock (“S” position) or by loosening the nut of the high-pressure fuel pipe on the pump side.

 **CAUTION!** When stopping the engine, reduce the load slowly. Do not stop the engine suddenly as it may cause the temperature to raise abnormally.

 **CAUTION!** Do not stop the engine using the decompression lever.

## SECTION 2 MAINTENANCE



**IMPORTANT!** This manual only provides information about additional procedures or procedures to be performed at different time intervals than found in the engine manufacturer's manuals. Refer to the [manufacturer's manual](#) for complete maintenance instructions.



**WARNING!** Remove the blade before performing any engine service. Failure to do so may result in serious injury.



**This symbol** identifies the interval (hours of operation) which each maintenance procedure should be performed. "AR" signifies maintenance procedures which should be performed as required.

### 2.1 Air Cooling System



Wash the engine or brush off sawdust and debris every 50 hours of operation. Clean the grass screen, cooling fins, and external surfaces. Remove any dust, dirt or oil. See engine manual for further instructions.

## 2.2 Air Filter & Pre-Cleaner



**WARNING!** Always wear proper and necessary safety equipment when performing service functions. Proper safety equipment includes eye protection, breathing protection, hand protection and foot protection.



Service the pre-cleaner every four hours of operation. Service by gently shaking excess sawdust and debris from the foam piece.



Clean the air filter (air cleaner element) and pre-cleaner (element wrapper) every eight hours of operation. See the engine manual for further instructions.



Change the air cleaner element every 6 months or 400 hours (or earlier if dirty).



**CAUTION!** Never run the engine without the element or with a defective element.

**CAUTION!** A clogged element hinders the flow of air to the combustion chamber. This reduces engine output, increases lube oil and fuel consumption and makes starting difficult.

**CAUTION!** Make sure you clean the element regularly.



## 2.3 Oil & Oil Filter

Change the oil after the first 50 hours of operation or after the first month (whichever comes first), and every 3 months or 200 hours thereafter.



**CAUTION!** Always drain the oil while the engine is still warm. It may be difficult to drain the oil completely when the engine is cold.

Change the oil filter every 6 months or 400 hours of operation.

Lube oil capacity: 1.65 l.



**CAUTION!** Before adding oil make sure the engine is not tilted.

## 2.4 Fuel Filter

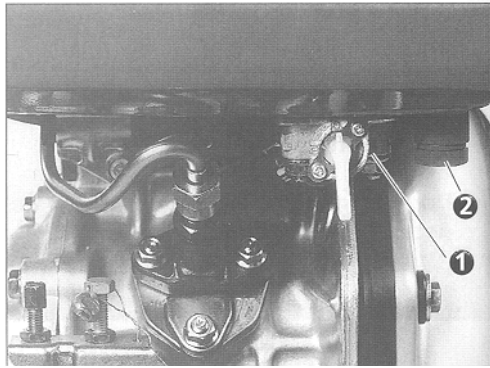

1 - Nuts, 2 - Drain plug

Clean: Every 3 months or 200 Hrs. Every 6 months or 400 Hrs.

The fuel filter has to be cleaned regularly to insure maximum engine output.

1. Drain fuel from the fuel tank.
2. Loosen the fuel cock nuts and remove the filter from the F.O. tank filler port. Wash the filter thoroughly with diesel oil.

## 2.5 Drive Belt Adjustment



**WARNING!** Do not for any reason adjust the engine drive belts or belt support bracket with the engine running. Doing so may result in serious injury.



Check the drive belt tension after the first 20 hours, and every 50 hours thereafter.

The drive belt tension should be adjusted with the tensioner handle engaged (in the up position), by moving the engine assembly on the engine mount plate. To make the adjustment, perform the following steps:

1. Loosen the engine mounting bolts and the jam nuts.
2. Using the adjustment bolts, shown in the figure below, adjust the belt tension to approximately 11 mm deflection with 7.2 kG of deflection force.
3. Tighten the jam nuts and the engine mounting bolts.

## 2 Maintenance

### Drive Belt Adjustment

See Figure 2-1.

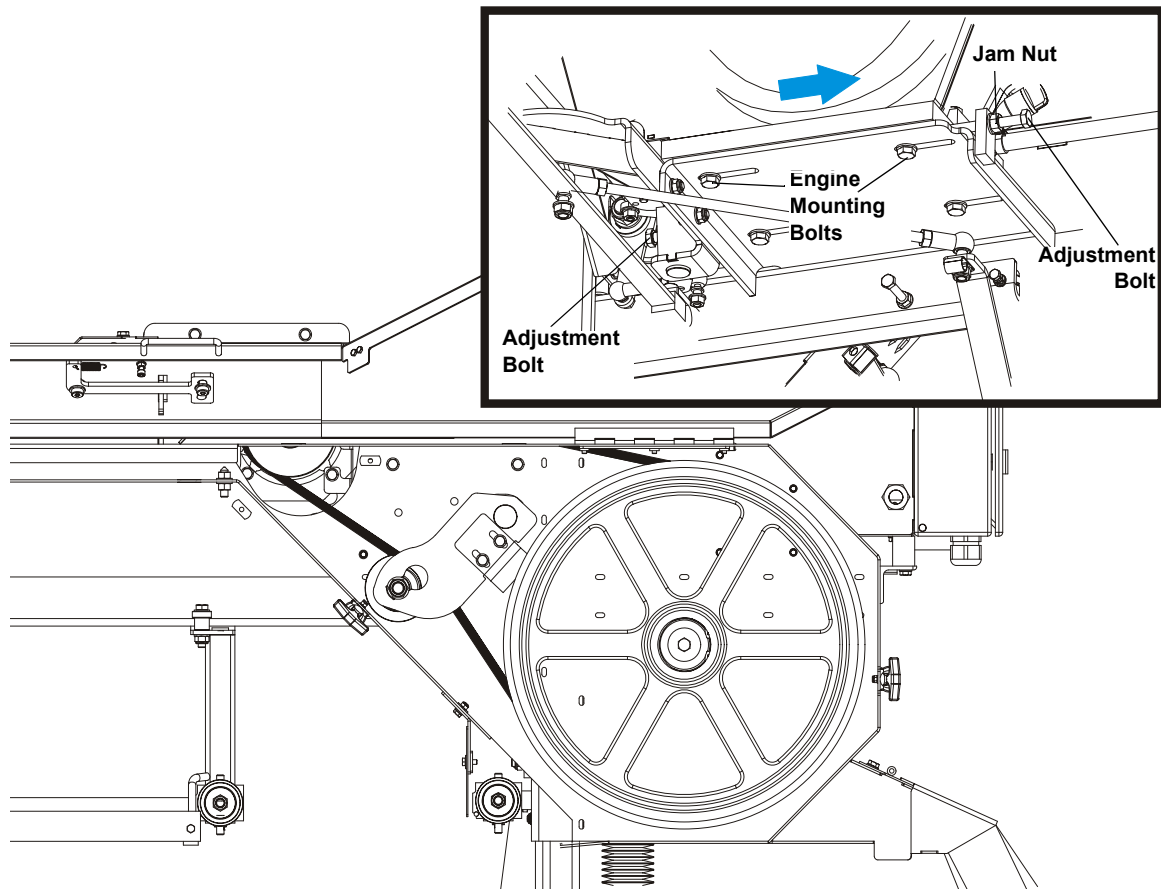

FIG. 2-1



Periodically check all belts for wear. Replace any damaged or worn belts as needed.

## 2.6 RPM Adjustments



**WARNING!** Remove the blade before performing any engine service. Failure to do so may result in serious injury.

200

Check the RPM with a tachometer after the first 20 hours of operation and every 200 hours thereafter. High-end RPM should be 3600 ( $\pm 100$ ) RPM and low-end RPM should be 1150 (not to exceed 1500).

Before checking the RPM, make sure belt and brake strap tension are correct (See Sawmill Maintenance).

1. Start the engine to measure the low-end RPM.

Make sure that the throttle linkage is not affecting the engine RPM while the clutch/brake handle is disengaged. Make sure the cable is not bent or kinked. Refer to the engine manual to adjust the low-end RPM.

2. Engage the clutch handle to throttle the engine and measure the high-end RPM. Readjust the throttle linkage if necessary to increase or reduce the high-end engine speed.

The engine should start to throttle as soon as you start moving the clutch handle down. If the engine dies instead, restart the engine and adjust the throttle linkage as far as possible without affecting low-end RPM. **NOTE:** A properly adjusted throttle will extend the cable spring 13 mm when running and have a slight amount of slack in the cable when idling.

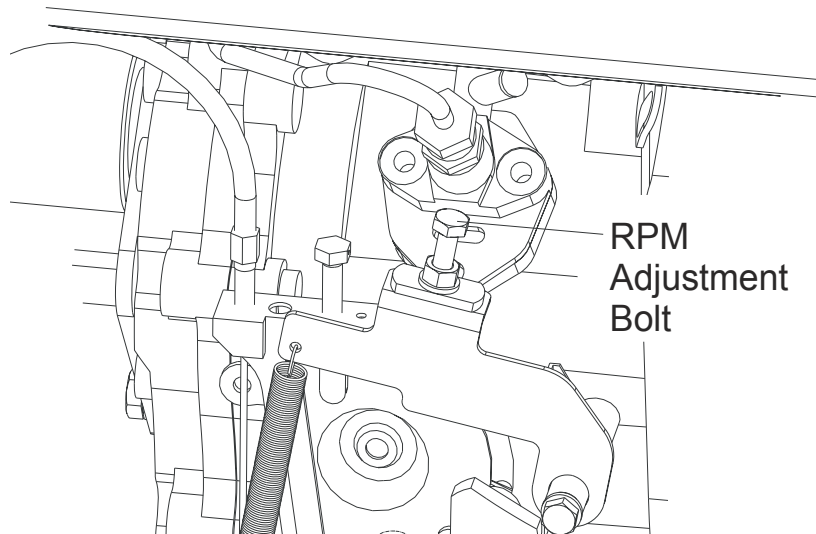

FIG. 2-1

## SECTION 3 REPLACEMENT PARTS

### 3.1 How To Use The Parts List

- Use the table of contents or the index to locate the assembly that contains the part you need.
- Go to the appropriate section and locate the part in the illustration.
- Use the number pointing to the part to locate the correct part number and description in the table.
- Parts shown indented under another part are included with that part.
- Parts marked with a diamond (◆) are only available in the assembly listed above the part.

See the sample table below. Sample Part #A01111 includes part F02222-2 and subassembly A03333. Subassembly A03333 includes part S04444-4 and subassembly K05555. The diamond (◆) indicates that S04444-4 is not available except in subassembly A03333. Subassembly K05555 includes parts M06666 and F07777-77. The diamond (◆) indicates M06666 is not available except in subassembly K05555.

<b>3.2 Sample Assembly</b>				
REF	DESCRIPTION (◆ Indicates Parts Available In Assemblies Only)	PART #	QTY.	
	<b>SAMPLE ASSEMBLY, COMPLETE (INCLUDES ALL INDENTED PARTS BELOW)</b>	A01111	1	
1	Sample Part	F02222-22	1	
	Sample Subassembly (Includes All Indented Parts Below)	A03333	1	
2	Sample Part (◆ Indicates Part Is Only Available With A03333)	S04444-4	1	◆
	Sample Subassembly (Includes All Indented Parts Below)	K05555	1	
3	Sample Part (◆ Indicates Part Is Only Available With K05555)	M06666	2	◆
4	Sample Part	F07777-77	1	

#### To Order Parts:

- From Europe call our European Headquarters and Manufacturing Facility in Kolo, Poland at **+48-63-2626000**. From the continental U.S., call **1-800-448-7881** to order parts. Have your customer number, vehicle identification number, and part numbers ready when you call.
- From other international locations, contact the Wood-Mizer distributor in your area for parts.

\* - parts available only in electric-start engine kits

### 3.3 Engine Assembly

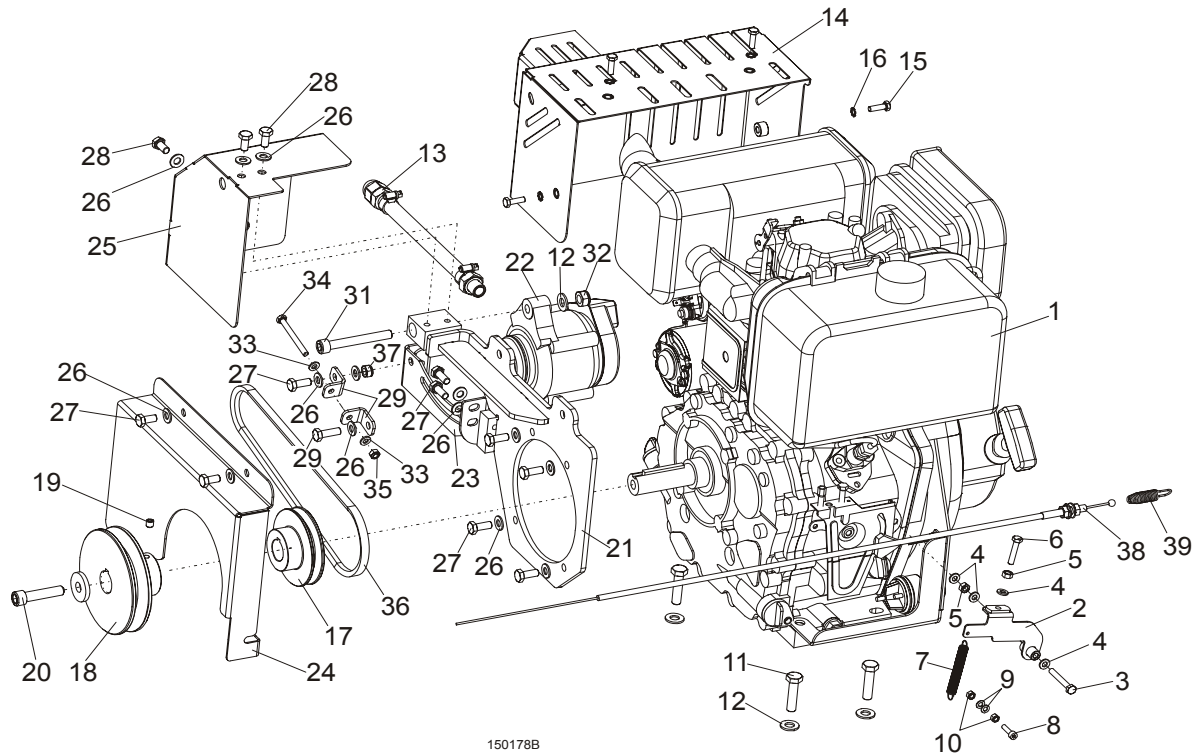

150178B

REF	DESCRIPTION (◆ Indicates Parts Available in Assemblies Only)	PART #	QTY.
	<b>MOUNT KIT, L100AE-DEYC ELECTRIC-START ENGINE</b>	095265	1
1	Engine, L100AE-DEYC YANMAR Electric-Start (*)	090130	1
	Muffler, #114970-13551	092614	1
	Gasket, #114699-13200 Muffler	092615	1
	Element, #114650-12591 Air Cleaner	090164	1
	Gasket, #114699-12210 Air Cleaner	092616	1
	Rope, #114699-76630 Starter	092617	1
	Spring, #114699-76540 Helical	092618	1
	Injector Assembly, #714650-53100 Fuel	092619	1
	Nozzle Assembly, #114650-53000 Fuel Injector	092620	1
	Filter, #114250-35110 Oil	090165	1
	Gasket Kit, #714988-92610	092621	1
	Filter, #114250-55121 Fuel	090163	1
	Rectifier, #160970-77350 (*)	093451	1
	Stator, #114399-78710 (*)	093452	1
	Starter, #114362-77011 (*)	093453	1
	Brush, (-) #114371-79040 (*)	093454	1
	Brush, (+) #114371-79050 (*)	093455	1

	Valve, Solenoid Complete (*)	098902	1	
	Shut-Off Weldment, Throttle Complete	091767	1	
2	Shut-Off Weldment, Throttle Painted	091764-1	1	
3	Bolt, M6x45-8.8 Hex Head Zinc	F81001-6	1	
4	Washer, M6 Flat Zinc	F81053-1	4	
5	Nut, M6-8 Hex Zinc	F81031-1	2	
6	Bolt, M6x30mm Hex Head Zinc Grade 8.8	F81001-8	1	
7	Spring, .8 x 9.5x76.2 Extension Zinc-Plated	091770	1	
8	Screw, M5x20-8.8 Hex Socket Head Cap Zinc	F81000-72	1	
9	Washer, M5 Flat Zinc	F81052-1	2	
10	Nut, M5 Hex Zinc Free Grade 5.8	F81030-1	2	
11	Bolt M10x40-8.8 Fe/Zn5	F81003-16	4	
12	Washer, M10 Flat Zinc	F81055-1	5	
13	Hose, D10 Oil Drain Complete	091755	1	
14	Mufler Cover, painted	093795-1	1	
15	Bolt M6x20-8.8-Zinc	F81001-2	4	
16	Washer, External Star 6,4 Zinc	F81053-2	4	
17	Pulley, 30A Alternator	095267-1	1	
18	Pulley, D10, G13, G15 Engine, Zinc-Plated	096447-1	1	
19	Screw, Set, M8x8-33H Fe/Zn Hex Sckt Head	F81014-1	1	
20	Screw, 7/16-20 x 1 1/2 SHC	F05007-55	1	
21	Bracket, 30A Alternator Upper	095271-1	1	
22	Alternator, D42	089661	1	
23	Bracket, "Denso" 30A Alternator	095268-1	1	
24	Cover, Alternator Belt	095323-1	1	
25	Cover, Alternator	095320-1	1	
26	Washer, M8, Flat, Zinc	F81054-1	14	
27	Bolt, M8x20mm Hex Head Zinc Grade 5.8	F81002-4	7	
28	Bolt, M8x16mm Hex Head Zinc Grade 5.8	F81002-20	5	
29	Tensioner, 30A Alternator Belt	095296-1	2	
30	Bolt, M8x25mm Hex Head Zinc Grade 5.8	F81002-5	1	
31	Screw, M10x80 -8.8 Hex Socket Head Cap Zinc	F81003-69	1	
32	Nut, M10 Hex Nylon Zinc Lock	F81033-1	1	
33	Washer, M6 Flat Zinc	F81053-1	2	
34	Bolt, M6x60mm Hex Head Zinc Grade 8.8	F81001-9	1	
35	Nut, M6, Hex, Nylon Lock Zinc	F81031-2	1	
36	V-Belt, AVX10x710La (CONTITECH)	095333	1	
37	Nut, M8, Hexagon, Nylon Lock Zinc	F81032-2	1	
38	Cable, LT15D10 Throttle	097699	1	
39	Spring, 35 x 9,5 x 1,6 Special	097443	1	
	<b>V-BELT, 17BX 2250 REF. BX87, 2210LI (GOOD-YEAR)</b>	097448	1	



### 3.4 Brake/Belt Tensioner Assembly

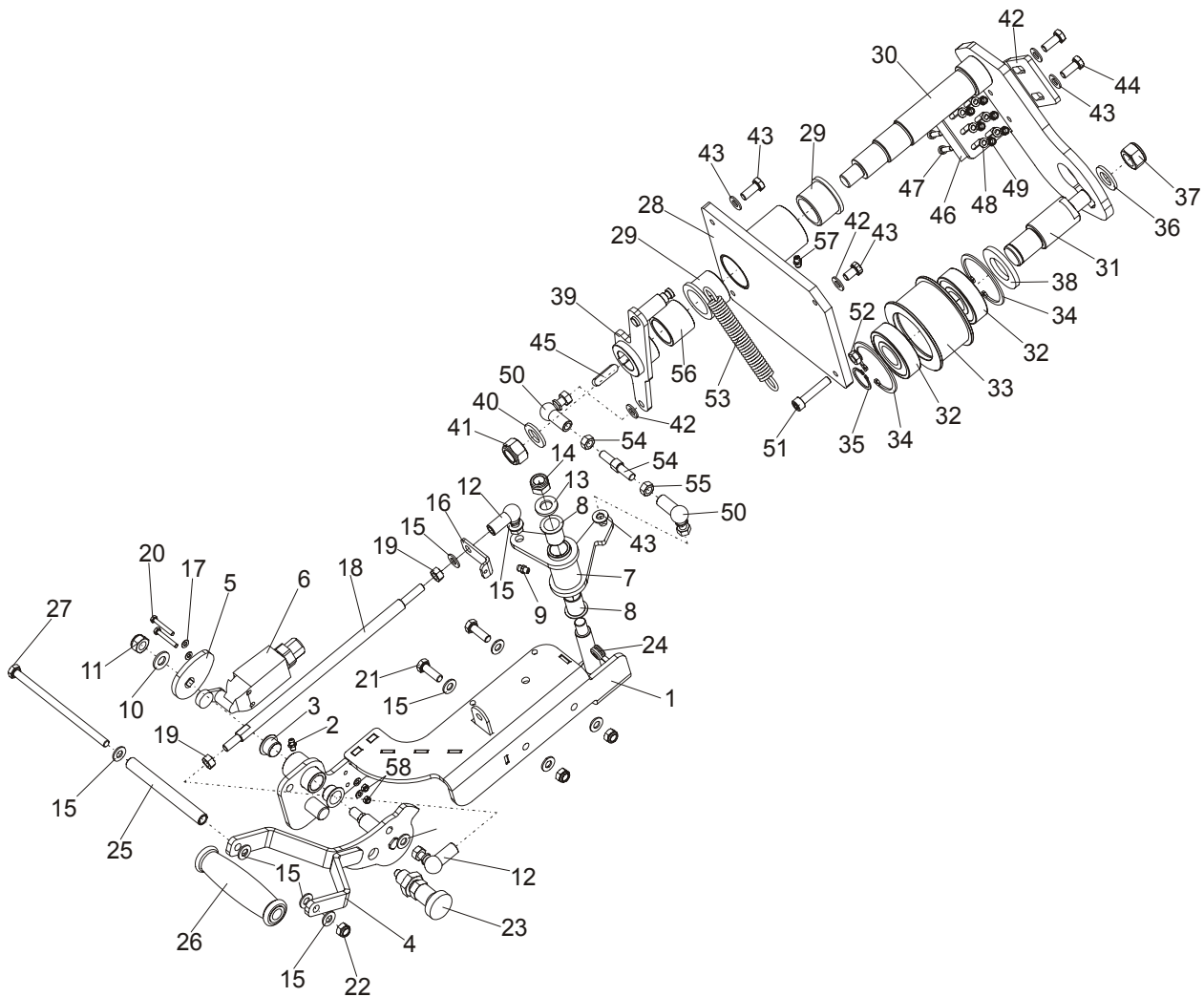

REF	DESCRIPTION (◆ Indicates Parts Available In Assemblies Only)	PART #	QTY.
	<b>BELT TENSIONER &amp; BRAKE ASSEMBLY</b>	096448	1
	HANDLE, TENSIONER AND BRAKE COMPLETE	097436	1
	Plate, Tensioner/Brake Handle Complete	097437	1
1	Plate, Tensioner/Brake Handle	097438-1	1
2	Fitting, M6 Type A Grease	086280	1
3	Bushing, GFM - 1618-12 Igus	091455	2
4	Grip, Tensioner/Brake Handle	095318-1	1

# 3

## Replacement Parts

### Brake/Belt Tensioner Assembly

5	Cam, LT15 Limit Switch Zinc	096969-1	1	
6	Limit Switch, EVN2000 A	091742	1	
	Angle Lever, Complete	097432	1	
7	Lever, Angle	097433-1	1	
8	Bushing, GFM 1719-25	094142	2	
9	Fitting, M6 Type A Grease	086280	1	
10	Washer, 10,5 Flat Zinc	F81055-1	1	
11	Nut, M10-8-B Hex Nylon Zinc Lock	F81033-1	1	
12	Pivot, FI 13-M8 (T17628-ULMER) Angle	095285	2	
13	Washer, 13 Flat Zinc	F81056-1	1	
14	Nut, M12-8 Hex Nylon Zinc Lock	F81034-2	1	
15	Washer, 8,4 Flat Zinc	F81054-1	11	
16	Plate, Tensioner	097442-1	1	
17	Washer, 4,3 Flat Zinc	F81051-2	4	
18	Pusher, M8 Long	097444-1	1	
19	Nut, M8-8-B Hex Zinc	F81032-1	2	
20	Bolt, M4x30 8.8 Hex Head Full Thread Zinc	F81011-5	2	
21	Bolt, M8x25-8.8-B Hex Head Full Thread Zinc	F81002-5	2	
22	Nut, M8-8-B Hex Nylon Zinc Lock	F81032-2	3	
23	Pin, 45308DNW Detent	089939	1	
24	Seal Wire, Rubber Inside Dia 6mm	085338	1	
25	Axle, Grip Rotation	097698-1	1	
26	Knob, 1.135/120-13 Crank Handle	097696	1	
27	Bolt, M8x150-8.8 Hex Head Zinc	F81002-36	1	
	TENSION ROLLER W/BRAKE, COMPLETE	097446	1	
28	Mount Wldmt, Tensioner Shaft Ptd	091112-1	1	
29	Bushing, MFM-3240-30 (IGUS)	088461	2	
30	Shaft, Belt Tensioner	096451-1	1	
	Roller, Tension Complete	097832	1	
31	Axle, Belt Tension Wheel Zinc	100232-1	1	
32	Bearing Wheel, Idle Side 6305 2RS NSK.	P08066	2	
33	Wheel, LT15 Belt Tension Zinc	087671-1	1	
34	Ring, 62W Inside Spring Retaining	F81090-1	2	
35	Ring, 25Z Outside Retaining	F81090-22	1	
36	Washer, 17 Flat Zinc	F81058-1	1	
37	Nut, M16-8-Hex Nylon Zinc Lock	F81036-2	1	
38	Washer, Tension Roller Axle, Zinc	100237-1	1	
39	Lever, Tensioner Double-Arm	096449-1	1	
40	Washer, 17 Flat Zinc	F81058-1	1	
41	Nut, M16-8-Hex Nylon Zinc Lock	F81036-2	1	
42	Bracket, Brake Block Mount Ptd	091248-1	1	
43	Washer, 8,4-Flat Zinc	F81054-1	7	
44	Bolt, M8x20-5.8-Hex Head Full Thread Zinc	F81002-1	5	

<b>45</b>	Key, A8x7x32 Parallel	088564	1	
<b>46</b>	Block, F9273 123 Drive Belt Tensioner Brake	092111	2	
<b>47</b>	Screw, M5x25-8.8-Hex Socket Head Cap Zinc	F81000-7	6	
<b>48</b>	Washer, 5,3 Flat Zinc	F81052-1	6	
<b>49</b>	Nut, M5-8-DIN 985 Zinc	F81030-2	6	
<b>50</b>	Pivot, FI 13-M8 (T17628-ULMER) Angle	095285	2	
<b>51</b>	Screw, M8x40 -8.8- Hex Socket Head Cap Zinc	F81002-29	1	
<b>52</b>	Nut, M8-8-B-FeZn5 Hex Nylon Zinc Lock	F81032-2	1	
<b>53</b>	Spring, FI 1,9 x fi 14,2 x 104	091865	1	
<b>54</b>	Pusher, Short Zinc	097445-1	1	
<b>55</b>	Nut, M8-8-B-Hex Zinc	F81032-1	2	
<b>56</b>	Bushing, Tensioner Zinc	097447-1	1	
<b>57</b>	Fitting, M6 Type A Grease	086280	1	
<b>58</b>	Nut, M4-B-Hex Zinc	F81029-1	2	

## 3 Replacement Parts

### Key Switch Mount Bracket

### 3.5 Key Switch Mount Bracket

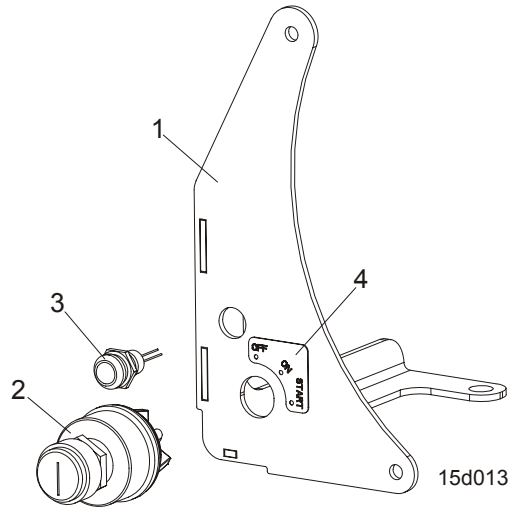

REF	DESCRIPTION (◆ Indicates Parts Available In Assemblies Only )	PART #	QTY.
	<b>BRACKET, D10 KEY SWITCH MOUNT COMPLETE</b>	092510	1
1	Bracket, D10 Key Switch Mount Painted	092511-1	1
2	Switch, Key	P04350	1
3	Light, KLA-GS-10-2 Control	091051	1
4	Decal, D10 Key Switch Mount Bracket	092517	1



## 4.2 Electrical Components, LT15D10

Symbol	Wood-Mizer Part No.	Description
B1	091775	Battery, 36Ah
S1	094328	Button, M22 Momentary Mushroom Green
Pk1	086486	Relay, D9120 IP 65/64
W1	094232	Safety switch - Guard
W2, W3	100910	Safety Switches, Up/Down
L1	091051	Light, KLA-GS-10-2 Control
SOL1	092803	Valve, ET-3 12V Fuel Solenoid
S3	095332	Joystick, 2-position Up/Down
S2	100931	Limit Switch, GLCB01A1B
L2	095331	Control Light

**TABELA 4-1**