

# **Wood-Mizer®**

## **Parts Manual**

---

**LT70L AH Super**

**rev. A3.00**



**Safety is our #1 concern!** Read and understand all safety information and instructions before operating, setting up or maintaining this machine.

*May 2012*

# Table of Contents

# Section-Page

Form #1061

*General Contact Information*

*Branches & Authorized Sales Centers Wood-Mizer Locations (North and South America)*

<b>SECTION 1</b>	<b>GENERAL INFORMATION</b>	<b>1-1</b>
1.1	How To Use The Parts List .....	1-1
1.2	Sample Assembly .....	1-1
<b>SECTION 2</b>	<b>BLADE GUIDE ROLLERS &amp; ARM</b>	<b>2-1</b>
2.1	Blade Guide Assembly, Idle Side .....	2-1
2.2	Blade Guide Assembly, Drive Side .....	2-2
2.3	Blade Guide Arm Drive Assembly.....	2-4
2.4	Blade Guide Mount Assembly, Drive Side .....	2-6
<b>SECTION 3</b>	<b>BLADE WHEELS &amp; TENSIONER</b>	<b>3-1</b>
3.1	Blade Drive Assembly.....	3-1
3.2	Idle Blade Wheel Assembly .....	3-2
3.3	Hydraulic Blade Tensioner Assembly.....	3-4
3.4	Sawdust Flow Guide.....	3-6
<b>SECTION 4</b>	<b>SAW HEAD</b>	<b>4-1</b>
4.1	Middle Throat Screw .....	4-1
4.2	Drive Belt Tensioner LT70 AC.....	4-1
4.3	Board Return Assembly (Optional) .....	4-2
4.4	Water Lube Assembly .....	4-4
4.5	LT70AC Saw Head Decals .....	4-5
4.6	Blade Housing Covers.....	4-7
4.7	Sawdust Chute.....	4-8
4.8	Saw Head Protection Kit, LT70L Mobile .....	4-9
<b>SECTION 5</b>	<b>CONTROL BOXES</b>	<b>5-1</b>
5.1	Control Assembly, LT70 AH .....	5-1
5.2	Control Assembly, LT70-RSW .....	5-2
5.3	Drum Switches .....	5-4
5.4	Circuit Breakers.....	5-5
5.5	Front Panel Assembly & Harnesses .....	5-6
5.6	Solenoids .....	5-7
<b>SECTION 6</b>	<b>UP/DOWN SYSTEM</b>	<b>6-1</b>
6.1	Up/Down Rollers & Covers .....	6-1
6.2	Blade Height Scale .....	6-2
6.3	Up/Down Chain & Sprockets.....	6-3
6.4	Up/Down Drive Assembly .....	6-4
6.5	Safety Switches .....	6-6

# Table of Contents

# Section-Page

<b>SECTION 7</b>	<b>FEED SYSTEM &amp; TRACK ROLLERS</b>	<b>7-1</b>
7.1	Upper Track Rollers And Wipers.....	7-1
7.2	Power Feed Assembly.....	7-3
7.3	Feed Chain/Stop.....	7-5
7.4	Lower Track Rollers.....	7-6
<b>SECTION 8</b>	<b>BED FRAME ASSEMBLY</b>	<b>8-1</b>
8.1	Bed Rail Assembly (L type frame).....	8-1
8.2	Bed Rail Assembly (L type frame).....	8-2
8.3	Bed Rail Assembly (L type frame).....	8-3
8.4	Leg, Stationary.....	8-4
8.5	Roller Assembly LT70 Remote.....	8-5
8.6	Pivot Bed Rail Assembly.....	8-6
8.7	Board Return Table.....	8-7
8.8	Bed Frame Decals.....	8-9
8.9	LT40/LT70 L & LT70M Super Saw Head Support Assembly,.....	8-10
8.10	Tie Down Chain Assembly.....	8-11
8.11	Remote Equipment Option.....	8-12
<b>SECTION 9</b>	<b>HYDRAULIC SYSTEM</b>	<b>9-1</b>
9.1	Hydraulic Hoses, LT70 AH14/15-ST.....	9-1
	<i>Protective Conduits, LT70L Super</i>	
9.2	Remote Control Box Parts.....	9-3
9.3	Hydraulic Log Loader, S/M Frame.....	9-6
9.4	Hydraulic Log Turner.....	9-7
9.5	Hydraulic Log Clamp,Front and Rear.....	9-9
9.6	Hydraulic Log Clamp, Additional.....	9-11
9.7	Hydraulic Log Clamp.....	9-13
9.8	Hydraulic Log Side Supports (for Stationary Sawmills).....	9-15
9.9	Hydraulic Toe Board.....	9-17
9.10	Power Roller.....	9-18

## Getting Service

Wood-Mizer is committed to providing you with the latest technology, best quality and strongest customer service available on the market today. We continually evaluate our customers' needs to ensure we're meeting current wood-processing demands. Your comments and suggestions are welcome.

### *General Contact Information*

From Europe call your local distributor or our European Headquarters and Manufacturing Facility in Koło, Nagórna 114 St, Poland at **+48-63-2626000**. From the continental U.S., call our U.S. Headquarter 8180 West 10th St.Indianapolis, IN 46214, toll-free at **1-800-525-8100**. Ask to speak with a Customer Service Representative. Please have your machine identification number and your customer number ready when you call. The Service Representative can help you with questions about the operation and maintenance of your machine. He also can schedule you for a service call.

### **Office Hours:**

<b>Country</b>	<b>Monday - Friday</b>	<b>Saturday</b>	<b>Sunday</b>
Poland	7 a.m.- 3 p.m.	Closed	Closed
US	8 a.m.- 5 p.m.	8 a.m.- 12 p.m	Closed

Please have your vehicle identification number and your customer number ready when you call.



Wood-Mizer will accept these methods of payment:

- Visa, Mastercard, or Discover
- COD
- Prepayment
- Net 15 (with approved credit)

Be aware that shipping and handling charges may apply. Handling charges are based on size and quantity of order.

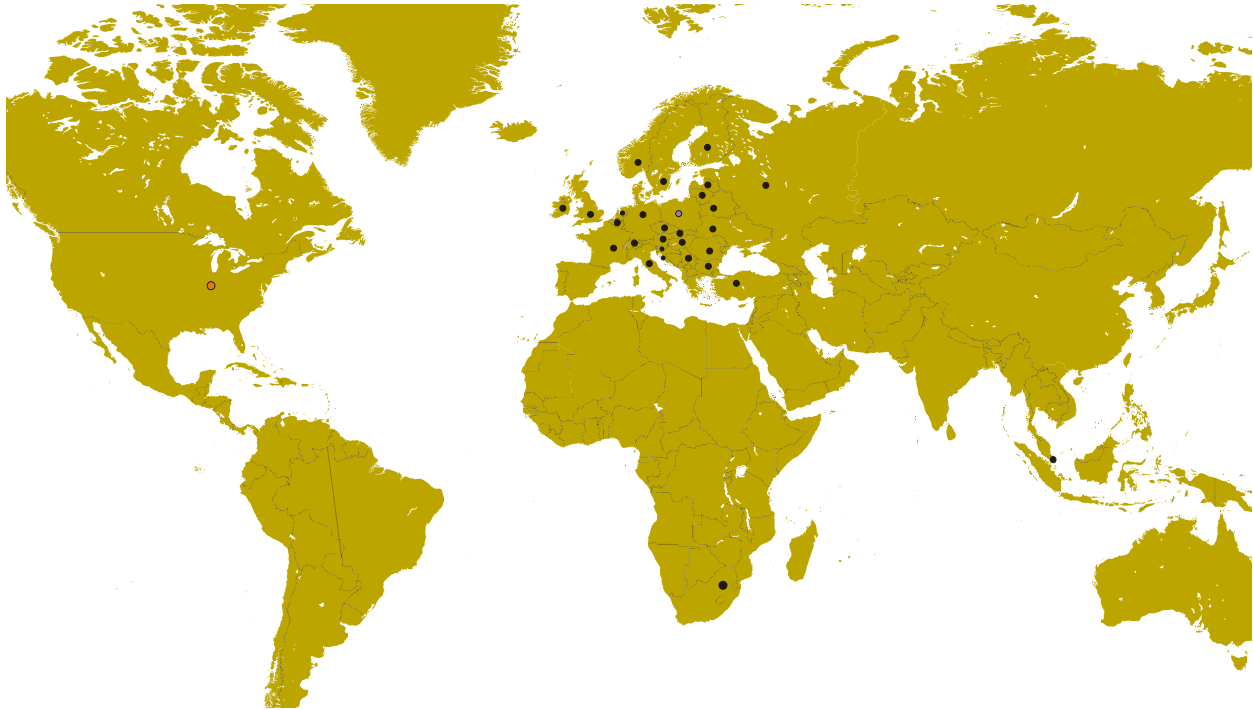
**Branches & Authorized Sales Centers Wood-Mizer Locations (North and South America)**



EUROPE		UNITED STATES
<p> <b>European Headquarters</b>  <b>Wood-Mizer Industries Sp. z o.o.</b>                      Nagórna 114, 62-600 Kolo, Poland                      Tel.: +48-63-26-26-000                      Fax: +48-63-27-22-327  <a href="http://www.woodmizer.eu">www.woodmizer.eu</a></p>		<p> <b>World Headquarters</b>  <b>Wood-Mizer LLC</b>                      8180 West 10th Street                      Indianapolis, Indiana 46214-2400,                      USA                      Tel.: +1-317-271-1542                      Fax: +1-317-273-1011  <a href="http://www.woodmizer.com">www.woodmizer.com</a></p>
<p><b>BELARUS</b>  <b>MOST-GRUPP</b>                      Siemashko 15, k.3                      Minsk 2200116                      Tel.: +375-17-270-90-08                      Fax: +375-17-270-90-08                      GSM: +375-29-649-90-80                      e-mail: <a href="mailto:most-by@mail.ru">most-by@mail.ru</a></p>	<p><b>SWITZERLAND Stefan Wespi</b>                      Maschinen u. Geräte                      Spezialarbeiten GmbH                      Eichstraße 4                      6353 Weggis                      Tel.: +41-(0)41 - 3900312                      GSM: +41-(0)79 - 9643594  <a href="mailto:wespi-landmaschinen@bluewin.ch">wespi-landmaschinen@bluewin.ch</a></p>	<p><b>RUSSIA Dariusz Mikołajewski</b>  <b>OOO WOOD-MIZER INDUSTRIES</b>                      141031, Moscow                      Reg., Mytishenski raj., pos. Veshki,                      Zavodskaja str., 3B                      Tel.Fax: +7(495) 788-72-35                      Tel.Fax: +7(495) 641-51-60                      e-mail: <a href="mailto:dariuszm@woodmizer-moscow.ru">dariuszm@woodmizer-moscow.ru</a></p>
<p><b>BULGARIA Kalin Simeonov</b>  <b>Ecotechproduct</b>                      38 Star Lozenski pat str.                      Sofia 1186                      Tel.: +359-2-462-7035                      Tel.: +359-2-963-1656                      Tel./Fax                      : +359-2-979-1710  <b>Kalin Simeonov</b>                      GSM: +3592-963-2559                      e-mail: <a href="mailto:office@ecotechproduct.com">office@ecotechproduct.com</a></p>	<p><b>HUNGARY Wiktor Turoczy</b>  <b>Wood-Mizer Hungary K.F.T.</b>                      Szonyi Ut 67., 2921 Komárom                      Tel./Fax: +36-34-346-255                      e-mail: <a href="mailto:woodmizer@woodmizer.hu">woodmizer@woodmizer.hu</a></p>	<p><b>RUSSIA Far East Wladimir Glazaczew</b>  <b>"WM Service"</b>                      Krasnoretschenskaya Str.111                      680006 Khabarovsk                      Tel./Fax: +7-914-541-1183                      e-mail: <a href="mailto:wms-khv@mail.ru">wms-khv@mail.ru</a></p>

<p><b>CROATIA Krešimir Pregernik</b>  <b>Pregimex d.o.o.</b>  S. Batušića 31, 10090 Zagreb  Tel./Fax: +3851-38-94-668  <b>Krešimir Pregernik</b>  GSM: +3851-98-207-106  e-mail: <a href="mailto:Kresimir.Pregernik@gmail.com">Kresimir.Pregernik@gmail.com</a></p>	<p><b>ITALY Pasquale Felice</b>  <b>Wood-Mizer Italia Srl</b>  <b>Cda. Capoiaccio SN</b>  86012 Cercemaggiore  Campobasso  Tel./Fax: +39-0874-798-357  GSM: +39-333-281-03-79  e-mail: <a href="mailto:wmitaliasrl@gmail.com">wmitaliasrl@gmail.com</a></p>	<p><b>SERBIA Dragan Markov</b>  <b>Wood-Mizer Balkan d.o.o.</b>  Svetosavska GA 3/3; P. Fah 25  23 300 Kikinda  Tel./Fax: +381-230-25-754  Tel./Fax: +381-230-23-567  GSM: +381-63-568-658  e-mail: <a href="mailto:office@woodmizer.co.yu">office@woodmizer.co.yu</a></p>
<p><b>CZECH REPUBLIC Miroslav Greill</b>  <b>Wood-Mizer CZ s.r.o.</b>  Osvaldova 91  339 01 Klatovy-Luby  Tel./Fax: +420-376-312-220  Fax: +420-376-319-011  <b>Miroslav Greill</b>  GSM: +420-723-580-799  e-mail: <a href="mailto:greill@woodmizer.cz">greill@woodmizer.cz</a></p>		<p><b>SLOVAKIA Wiktor Turoczy</b>  <b>Wood-Mizer Danubia s.r.o.</b>  Hadovce 5, 94501 Komárno  Tel.: +421-35-77-40-316  Fax: +421-35-7740-326  GSM: +421-905-930-972  e-mail: <a href="mailto:woodmizer@woodmizer.sk">woodmizer@woodmizer.sk</a></p>
<p><b>CZECH REPUBLIC Lubomir Kudlik</b>  <b>Wood-Mizer Moravia</b>  Sovadinova 6  69002 Breclav  Tel./Fax: +420-519-322-443  <b>Lubomir Kudlik</b>  GSM: +420-602-734-792  e-mail: <a href="mailto:info@wood-mizer.net">info@wood-mizer.net</a></p>	<p><b>LATVIA Vilmars Jansons</b>  <b>OBERTS Ltd</b>  Gaujas str. 32/2  LV-2167 Marupe, Rigas Raj.  Tel.: +371-7-810-666  Fax: +371-7-810-655  <b>Vilmars Jansons</b>  GSM: +371-92-06-966  <b>Andris Orols</b>  GSM: +371-28-33-07-90  e-mail: <a href="mailto:andris@oberts.lv">andris@oberts.lv</a></p>	<p><b>TURKEY</b>  <b>Er-Ka Ahsap Profil Kerestecilik San. ve Tic. Ltd. Sti.</b>  Adana Keresteciler Sitesi 191 sk No.41  ADANA  Tel.: +90-322-346-15-86  Fax: +90-322-345-17-07  GSM: +90-533-363-18-44  e-mail: <a href="mailto:info@erkaahsap.com.tr">info@erkaahsap.com.tr</a></p>
<p><b>FINLAND Howard Blackbourn</b>  <b>Oy Falkberg Jordbruk Ab</b>  Falkintie 220  25610 Ylonkyla  Tel.: +358-2732-2253  Fax: +358-2732-2263  <b>Howard Blackbourn</b>  GSM: +358-440-424-339  e-mail: <a href="mailto:falkberg@woodmizer.fi">falkberg@woodmizer.fi</a></p>	<p><b>LITHUANIA Andrius Zuzevicius</b>  <b>UAB Singlis</b>  Savanoriu pr. 187, 2053 Vilnius  Tel.: +370-5-2-32-22-44  Fax: +370-5-2-64-84-15  GSM: +370-620-28-645  e-mail: <a href="mailto:andrius.z@singlis.lt">andrius.z@singlis.lt</a></p> <p><b>Dmitrij Gaiduk</b>  GSM: +370-69-84-51-91  e-mail: <a href="mailto:dmitrijus.g@singlis.lt">dmitrijus.g@singlis.lt</a></p>	<p><b>UKRAINE Ivan Vinnicki</b>  <b>MOST UKRAINA</b>  bul. Myru 3, Bajkivtsi Ternoplskyj r-j  Ternopolska oblast  47711 Ukraine  Tel/Fax: +38 (0352) 52 37 74  GSM: +38 (067) 352 54 34  GSM: +38 (067) 674 50 68  E-mail: <a href="mailto:most-ukraina@ukr.net">most-ukraina@ukr.net</a></p>
<p><b>FRANCE Tizoc Chavez</b>  Wood-Mizer France  556 chemin des Embouffus,  ZAC des Basses Echarrieres  38440 SAINT JEAN DE BOURNAY  Tel: +33-4 74 84 84 44  GSM: +33-607 52 02 82  Mail: <a href="mailto:tchavez@woodmizer.fr">tchavez@woodmizer.fr</a></p>	<p><b>NORWAY Odd Edvoll</b>  <b>Wood-Mizer Nordic AS</b>  Vardelia 17, 2020 Skedsmokorset  Tel.: +47-63-87-49-89  Fax: +47-63-87-37-66  GSM: +47-930-42-335  e-mail: <a href="mailto:odd.edvoll@woodmizer.no">odd.edvoll@woodmizer.no</a></p> <p>e-mail: <a href="mailto:firmapost@woodmizer.no">firmapost@woodmizer.no</a></p>	<p><b>UNITED KINGDOM &amp; IRELAND</b>  <b>Wood-Mizer UK</b>  Hopfield Barn  Kenward Road, Yalding  Kent ME18 6JP, UK  Tel.: +44-1622-813-201  Fax: +44-1622-815-534  e-mail: <a href="mailto:info@woodmizer.co.uk">info@woodmizer.co.uk</a></p>
<p><b>SLOVENIA Jan Fale</b>  <b>FAMTEH d.o.o.</b>  Gacnikova pot 2,  2390 Ravne na Koroskem  Tel.: +386-2-62-04-232  Fax: +386-2-62-04-231  <b>Jan Fale</b>  GSM: +386-2-62-04-230  e-mail: <a href="mailto:jan.fale@famteh.si">jan.fale@famteh.si</a></p> <p><b>Matjaz Kolar</b>  Tel.: +386-2-62-04-232  GSM: +386-31-775-999  e-mail: <a href="mailto:matjaz.kolar@famteh.si">matjaz.kolar@famteh.si</a></p>		

<p><b>GERMANY Klaus Longmuss</b>  <b>Wood-Mizer Sägewerke GmbH</b>  Dorfstraße 5, 29485 Schletau  Tel.: +49-5883-9880-10  Fax: +49-5883-9880-20  e-mail: <a href="mailto:info@woodmizer.de">info@woodmizer.de</a></p> <p><b>Klaus Longmuss</b>  Tel.: +49-5883-9880-12  GSM: +49-17-298-55-892  e-mail: <a href="mailto:KLongmuss@woodmizer.de">KLongmuss@woodmizer.de</a></p>	<p><b>Subagent:</b>  <b>SWEDEN Kjell Larsson</b>  <b>Mekwood AB</b>  Slingan 14, 812 41 Gästrike-Hammarby  Tel.: +46-290-515-65  <b>Kjell Larsson</b>  GSM: +46-706-797-965  e-mail: <a href="mailto:kjell.larsson@mekwood.se">kjell.larsson@mekwood.se</a></p>	<p><b>IRELAND</b>  <b>Wood-Mizer Ireland</b>  Stephen Brennan  Cum Lahardane Ballina County Mayo  Tel:+353 96 51345</p> <p>E-mail: <a href="mailto:brennanmill@ericom.net">brennanmill@ericom.net</a></p>
<p><b>Subagents:</b>  <b>DENMARK Brian Jensen</b>  Arnborgvej 9, 7330 Brande- Fasterholt  Tel.: +45-971-88-265  Fax: +45-971-88-266</p> <p><b>Brian Jensen</b>  GSM: +45-23-49-5828  e-mail: <a href="mailto:Fasterholt-Savvaerk@Mail.Tele.dk">Fasterholt-Savvaerk@Mail.Tele.dk</a></p>	<p><b>ROMANIA Adrian Echert</b>  <b>SC WOOD-MIZER RO SRL</b>  TRANSILVANIEI Nr. 5  Sibiu, Cisnădie 555300  Tel./Fax: : +40-369-405-433  GSM: +40-745-707-323  e-mail: <a href="mailto:aechert@woodmizer.ro">aechert@woodmizer.ro</a></p>	<p>Regional Manager - Asia  Wood-Mizer Asia Pte Ltd.  James Wong  Tel: +65 81216910  Fax: +65 6283 8636  WWW: <a href="http://www.woodmizerasia.com">www.woodmizerasia.com</a>  E-mail: <a href="mailto:jwong@woodmizerasia.com">jwong@woodmizerasia.com</a></p>
<p><b>Netherlands Chris Dragt</b>  Lange Brink 77d,  7317 BD Apeldoorn  Tel.: +31-55312-1833  Fax: +31-55312-2042  e-mail: <a href="mailto:Info@dragtbosbouw.nl">Info@dragtbosbouw.nl</a></p>	<p><b>Subagent:</b>  <b>ROMANIA M. Echert</b>  <b>S.C. Echert Comprod s.r.l</b>  Str. Schitului Nr. 6, Apt.7 etajul-1  725 70 Vatra Dornei, Romania  Tel./Fax: +40-230-374-235  Tel. : +40-740-35-35-74</p>	<p>Regional Manager - Africa  Wood-Mizer Africa  Jean-Jacques Oelofse  UNIT 3, LEADER PARK, NO: 20 CHARIOT ROAD  STORMILL, EXT 5, Roodepoort,  Johannesburg  Tel: +27 011 473 1313  Fax: +27 011 473 2005  Jean-Jacques Oelofse E-mail:  <a href="mailto:jjoelofse@woodmizer africa.com">jjoelofse@woodmizer africa.com</a>  Jean-Jacques Oelofse  Skype:jean.jacques.pierre.oelofse</p>

## USA World Headquarters

*Serving North & South America, Oceania, East Asia*

Wood-Mizer LLC  
8180 West 10th Street  
Indianapolis, IN 46214

Phone: 317.271.1542 or 800.553.0182  
Customer Service: 800.525.8100  
Fax: 317.273.1011  
Email: [infocenter@woodmizer.com](mailto:infocenter@woodmizer.com)

## Brazil Headquarters

*Serving Brazil*

Wood-Mizer do Brasil  
Rua Dom Pedro 1, No: 205 Bairro: Sao Jose  
Ivoti/RS CEP:93.900-000

Tel: +55 51 9894-6461/ +55 21 8030-3338/ +55 51  
3563-4784  
Email: [info@woodmizer.com.br](mailto:info@woodmizer.com.br)

## Canadian Headquarters

*Serving Canada*

Wood-Mizer Canada  
396 County Road 36, Unit B  
Lindsay, ON K9V 4R3

Phone: 705.878.5255 or 877.357.3373  
Fax: 705.878.5355  
Email: [ContactCanada@woodmizer.com](mailto:ContactCanada@woodmizer.com)

## Europe Headquarters

*Serving Europe, Africa, West Asia*

Wood-Mizer Industries Sp z o.o.  
Nagorna 114  
62-600 Kolo, Poland

Phone: +48.63.26.26.000  
Fax: +48.63.27.22.327

## Branches & Authorized Sales Centers

For a complete list of dealers, visit [www.woodmizer.com](http://www.woodmizer.com)

## SECTION 1 GENERAL INFORMATION

### 1.1 How To Use The Parts List

- Use the index above to locate the assembly that contains the part you need.
- Go to the appropriate section and locate the part in the illustration.
- Use the number pointing to the part to locate the correct part number and description in the table.
- Parts shown indented under another part are included with that part.
- Parts marked with a diamond (◆) are only available in the assembly listed above the part.

See the sample table below. Sample Part #A01111 includes part F02222-2 and subassembly A03333. Subassembly A03333 includes part S04444-4 and subassembly K05555. The diamond (◆) indicates that S04444-4 is not available except in subassembly A03333. Subassembly K05555 includes parts M06666 and F07777-77. The diamond (◆) indicates M06666 is not available except in subassembly K05555.

1.2 Sample Assembly				
REF	DESCRIPTION (◆ Indicates Parts Available In Assemblies Only)	PART #	QTY.	
	Sample Assembly, Complete (Includes All Indented Parts Below)	A01111	1	
1	Sample Part	F02222-22	1	
	Sample Subassembly (Includes All Indented Parts Below)	A03333	1	
2	Sample Part (◆ Indicates Part Is Only Available With A03333)	S04444-4	1	◆
	Sample Subassembly (Includes All Indented Parts Below)	K05555	1	
3	Sample Part (◆ Indicates Part Is Only Available With K05555)	M06666	2	◆
4	Sample Part	F07777-77	1	

#### To Order Parts:

- From Europe call our European Headquarters and Manufacturing Facility in Kolo, Poland at **+48-63-2626000**. From the continental U.S., call our toll-free Parts hotline at **1-800-525-8100**. Have your customer number, vehicle identification number, and part numbers ready when you call. From other international locations, contact the Wood-Mizer distributor in your area for parts.

#### Office Hours:

Country	Monday - Friday	Saturday	Sunday
Poland	7-15	Closed	Closed
US	8 a.m.- 5 a.m.	8 a.m.- 12 p.m.	Closed



**CAUTION!** It is strongly recommended that only original spare parts be used.



**SECTION 2 BLADE GUIDE ROLLERS & ARM**

**2.1 Blade Guide Assembly, Idle Side**

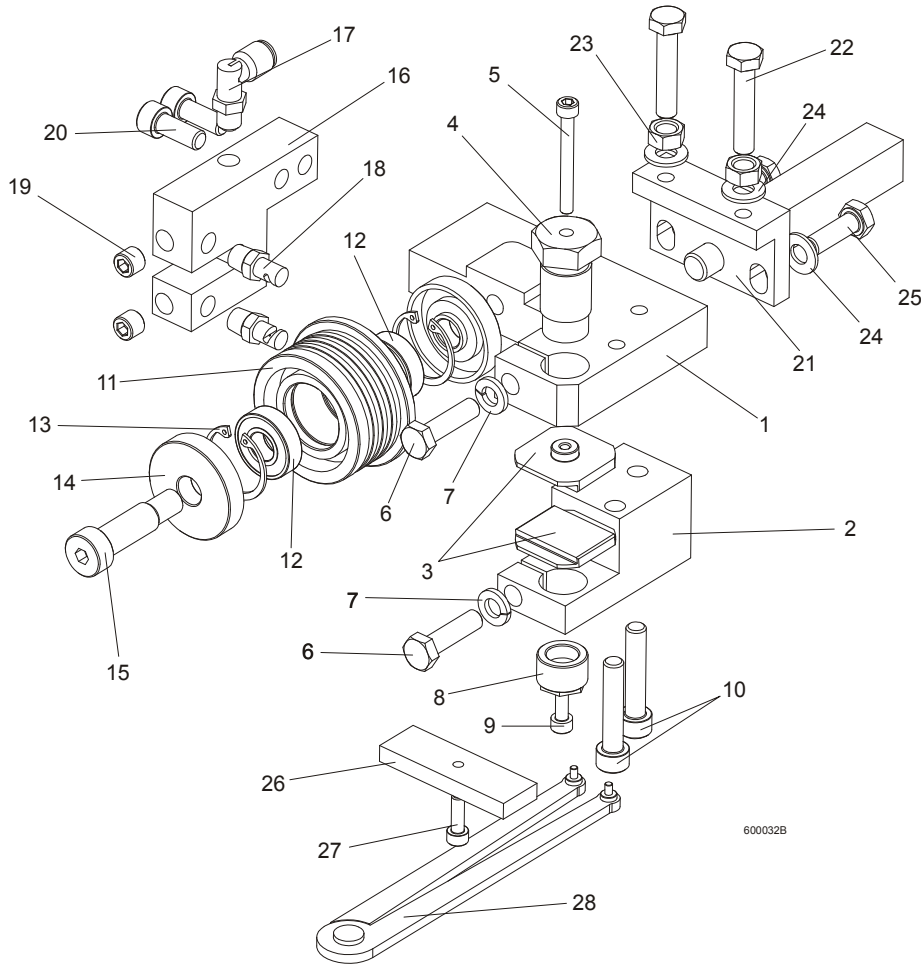

600032B

REF.	DESCRIPTION (◆ Indicates Parts Available In Assemblies Only)	PART#	QTY.
	<b>BLADE GUIDE ASSEMBLY, IDLE SIDE, EXTENDED</b> (for optional use with 1 1/2" blades)	092997	1
1	Block, Blade Guide Mount Zinc-plated	090947-1	1
2	Block, Lower Ceramic Pad Mount Zinc-plated	090948-1	1
3	Block, Blade Guide Zinc	093430-1	2
4	Bolt, Upper Pad Adjustment Zinc-plated	089515-1	1
5	Screw, M5x45 DIN912 A2-70 Hex Socket Head Cap Stainless Steel	F81000-24	1
6	Bolt, M8x30 DIN933 A2-70 Stainless Steel	F81002-27	2
7	Washer, 8.2 Split Lock Zinc	F81054-4	2
8	Screw, Lower Pad Adjuster Zinc-plated	516191-1	1
9	Screw, M5x10 DIN912 A2-70 Hex Socket Head Cap Stainless Steel	F81000-23	1
10	Screw, M8x40-8.8 Hex Socket Head Cap Zinc	F81002-29	2
	Roller, Blade Guide W/Bearing, Extended	092939	1
11	Roller, Blade Guide Extended	087890	1
12	Bearing, 6001 2RSR NACHI	087893	2
13	Ring, W28 Inside Retaining	F81090-9	2

# BLADE GUIDE ROLLERS & ARM

## Blade Guide Assembly, Drive Side

14	Washer, Blade Guide Roller Spacer Zinc-plated	087891-1	1	
	Washer, Blade Guide Roller Spacer Zinc-plated	087892-1	1	
15	Screw, 12/M10x30 12.9 ISO 7379 Socket Head Shoulder	F81003-70	1	
	Screw, 12/M10x35 12.9 ISO 7379 Socket Head Shoulder, (used with the Extended Roller only)	F81003-48	1	
16	Block, Nozzle Mounting Zinc-plated	090487-1	1	
17	Fitting, 90° Elbow 1/8NPT-1/4 Tube Swivel	P09736	1	
18	Nozzle, Blade Lube Spray	033479	2	
19	Plug, M10x1 DIN 906 BN40 "BOSSARD"	F81015-3	2	
20	Screw, M8x20-8.8 Hex Socket Head Cap Zinc	F81002-30	2	
21	Pivot Weldment, Blade Guide Zinc-plated	089509-1	1	
22	Bolt, M8x40 DIN933 A2-70 Stainless Steel	F81002-28	2	
23	Nut, M8 DIN934 A2-70 Stainless Steel	F81032-7	2	
24	Washer, 8.4 Zinc Flat	F81054-1	4	
25	Bolt, M8x25 DIN933 A2-70 Stainless Steel	F81002-26	2	
	Block, Blade Guide Alignment	090951	1	
26	Block, Blade Guide Alignment Zinc-plated	090805-1	1	
27	Screw, M5x16-8.8 Hex Socket Head Cap Zinc	F81000-25	1	
28	Tool, 62860-3 (PERSCHMAN) Lower Pad Adjustment	090949	1	

## 2.2 Blade Guide Assembly, Drive Side

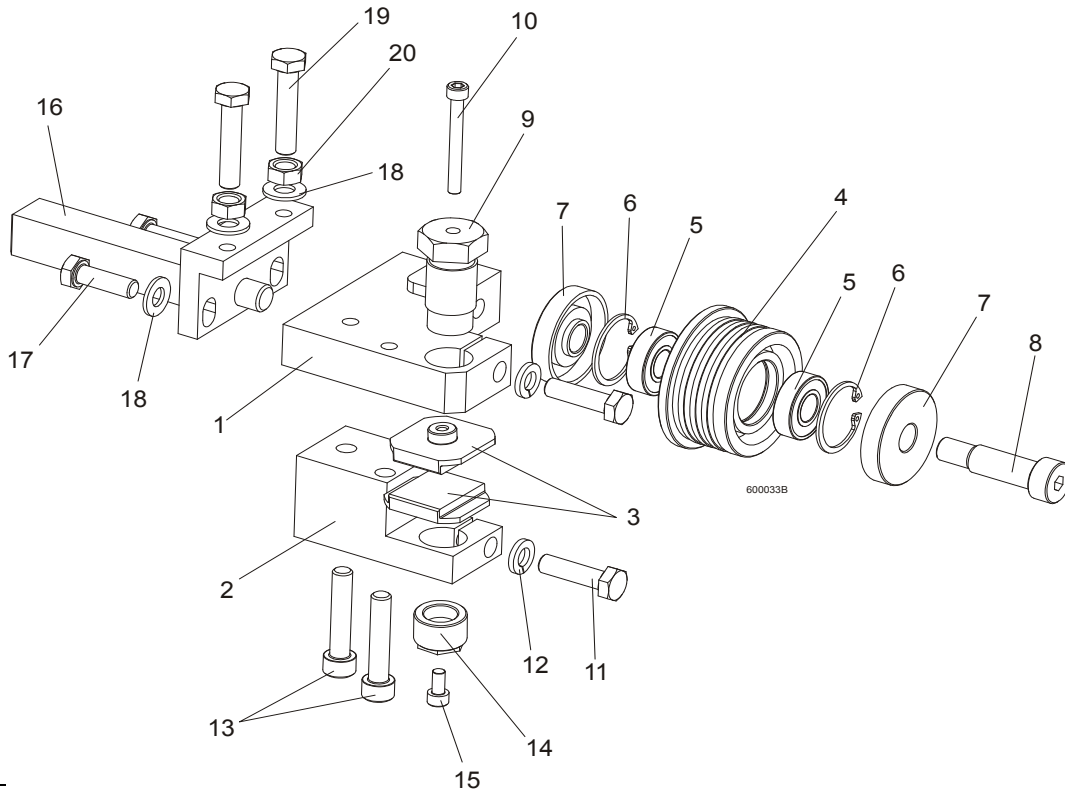

REF.	DESCRIPTION (◆ Indicates Parts Available In Assemblies Only)	PART#	QTY.	
	<b>BLADE GUIDE ASSEMBLY, DRIVE SIDE, EXTENDED</b> (for optional use with 1 1/2" blades)	092998	1	
1	Block, Blade Guide Mount Zinc-plated	090944-1	1	
2	Block, Lower Ceramic Pad Mount Zinc-plated	090946-1	1	

<b>3</b>	Block, Blade Guide Zinc	093430-1	2	
	Roller, Blade Guide W/Bearing, Extended	092939	1	
<b>4</b>	Roller, Blade Guide Extended	087890	1	
<b>5</b>	Bearing, 6001 2RSR NACHI	087893	2	◆
<b>6</b>	Ring, W28 Inside Retaining	F81090-9	2	
<b>7</b>	Washer, Blade Guide Roller Spacer Zinc-plated	087891-1	1	
	Washer, Blade Guide Roller Spacer Zinc-plated	087892-1	1	
<b>8</b>	Screw, 12/M10x30 12.9 ISO 7379 Socket Head Shoulder	F81003-70	1	
	Screw, 12/M10x35 12.9 ISO 7379 Socket Head Shoulder (used with the Extended Roller only)	F81003-48	1	
<b>9</b>	Bolt, Upper Pad Adjustment	089515	1	
<b>10</b>	Screw, M5x45 DIN912 A2-70 Hex Socket Head Cap Stainless Steel	F81000-24	1	
<b>11</b>	Bolt, M8x30 DIN933 A2-70 Stainless Steel	F81002-27	2	
<b>12</b>	Washer, 8.2 Split Lock Zinc	F81054-4	2	
<b>13</b>	Screw, M8x40-8.8 Hex Socket Head Cap Zinc	F81002-29	2	
<b>14</b>	Screw, Lower Pad Adjustment Zinc-plated	516191-1	1	
<b>15</b>	Screw, M5x10 DIN912 A2-70 Hex Socket Head Cap Stainless Steel	F81000-23	1	
<b>16</b>	Pivot Weldment, Blade Guide Zinc-plated	089509-1	1	
<b>17</b>	Bolt, M8x25 DIN933 A2-70 Stainless Steel	F81002-26	2	
<b>18</b>	Washer, 8.4 Zinc Flat	F81054-1	4	
<b>19</b>	Bolt, M8x40 DIN933 A2-70 Stainless Steel	F81002-28	2	
<b>20</b>	Nut, M8 DIN934 A2-70 Stainless Steel	F81032-7	2	

# 2 BLADE GUIDE ROLLERS & ARM

## Blade Guide Arm Drive Assembly

### 2.3 Blade Guide Arm Drive Assembly

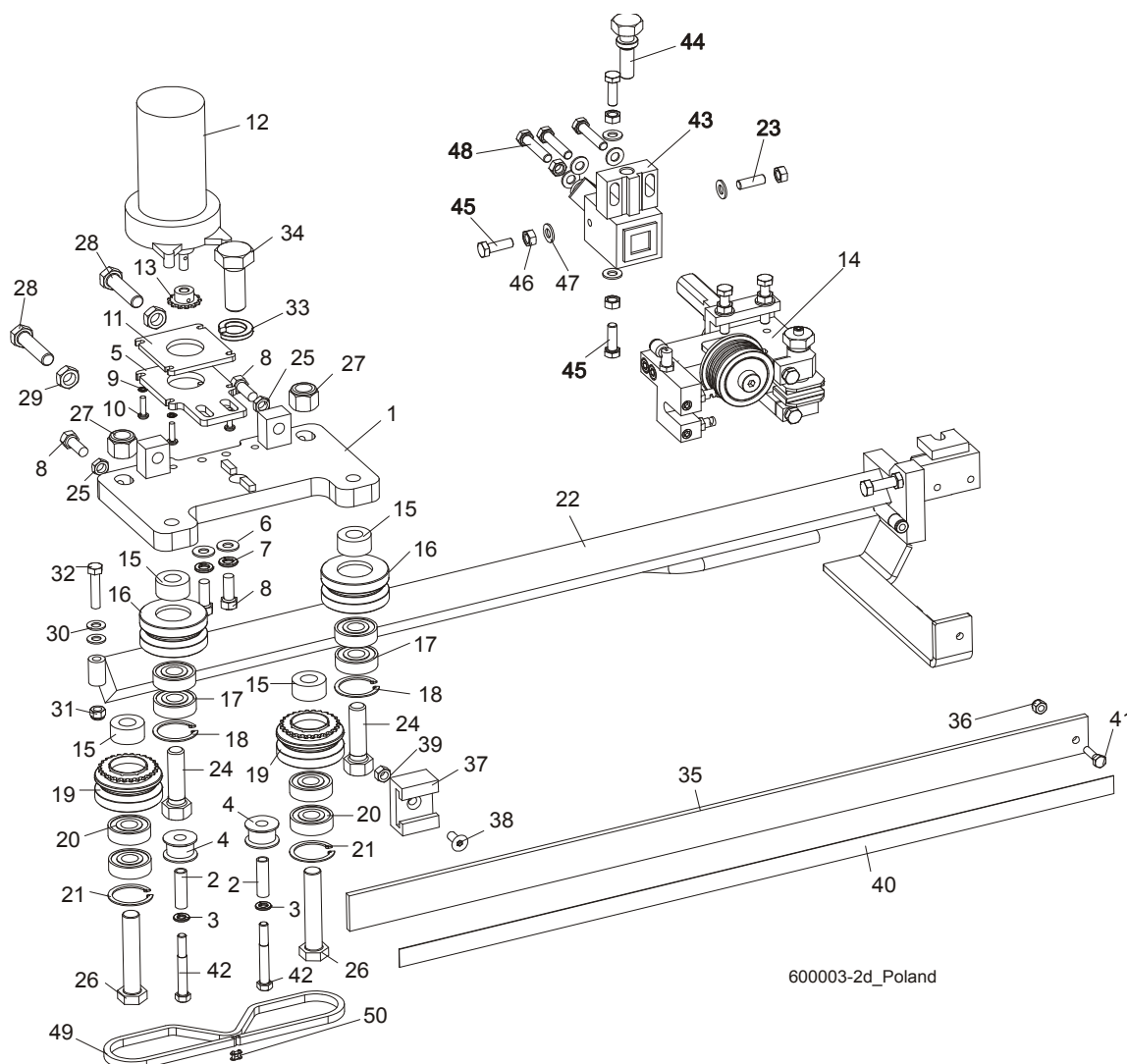

600003-2d\_Poland

REF.	DESCRIPTION (◆ Indicates Parts Available In Assemblies Only)	PART#	QTY.
	<b>BLADE GUIDE ARM ASSEMBLY</b>	090950	1
1	Plate Weldment, Blade Guide Arm Zinc-plated	090800-1	1
2	Bushing, 0.322 x 0.44 x 1 1/2" Spacer	S09996	2
3	Washer, 5/16" Split Lock Zinc	F05011-13	2
4	Roller, Chain Guide	090801	2
5	Plate, Blade Guide Motor Mount Ptd	090803-1	1
6	Washer, 10.5 Zinc Flat	F81055-1	2
7	Washer, 3/8" Zinc Flat	F05011-4	2
8	Bolt, M10 x 25 8.8 Hex Head Full Thread	F81003-31	4
9	Washer, 5.3 Zinc Flat	F81052-1	4
10	Screw, #10-32 x 3/4 CrS1 Phillips Head	F05004-38	4
11	Plate, Spacer Ptd	090802-1	1
12	Motor, 53:1 Gear ASA Blade Guide Arm	P09698-1	1
13	Sprocket, 25B13 x .3130	P09970	1
14	Pin, 3 x 14 Zinc Roll	F81044-4	1

# BLADE GUIDE ROLLERS & ARM

## Blade Guide Arm Drive Assembly

2

15	Spacer, Drive Roller Zinc-plated	090804-1	4	
	<b>ROLLER ASSEMBLY, BLADE GUIDE ARM IDLER</b>	042543	2	
16	Housing, 2 1/2" V-Groove	042536	1	
17	Bearing, 6203 2RSP6-5/8 CX	095087	2	
18	Ring, 1.575" ID 5002-156 Retaining	F04254-8	1	
	<b>ROLLER ASSEMBLY, BLADE GUIDE ARM DRIVE</b>	042542	2	
19	Housing, 2 1/2" V-Groove W/Sprocket	042541	1	
20	Bearing, 6203 2RSP6-5/8 CX	095087	2	
21	Ring, 1.575" ID 5002-156 Retaining	F04254-8	1	
22	Arm Weldment, Blade Guide Zinc-plated	090479-1	1	
23	Screw, Set, M8x8-33H FE/ZN Hex Socket Head, Stainless	F81014-3	1	
24	Bolt, 5/8-18 x 2 1/4 Hex Head Grade 5	F05009-80	2	
25	Nut, M10-04-W Zinc Hex Thin	F81033-6	2	
26	Bolt, 5/8-18 x 3 1/4 Hex Head Grade 5	F05009-80	2	
27	Nut, 5/8-18 Hex Nylon Lock	F05010-71	2	
28	Screw, M12 x 1.25 x 60-33H Zinc Hex Set W/Full Dog Point	F81004-52	2	
29	Nut, M12 x 1.25 8.8 Zinc Hex Thin	F81034-5	2	
30	Washer, 8.4 Zinc Flat	F81054-1	1	
31	Nut, M8-8-B Hex Nylon Zinc Lock	F81032-2	1	
32	Bolt, M8 x 40-8.8 Hex Head Full Thread Zinc	F81002-15	1	
33	Washer, DIN 6319-21C Spherical	F81059-6	1	
34	Bolt, M20 x 1.5 x 50-8.8-B Hex Head Full Thread Zinc	F81007-2	1	
35	Guard, Blade	088306	1	
36	Nut, M6-8-B Hex Nylon Zinc Lock	F81031-2	1	
37	Guide, Blade Guard	088305	1	
38	Screw, M8 x 25 Cross Recessed Countersunk Head Zinc	F81002-51	1	
39	Nut, M8-8-B Hex Nylon Zinc Lock	F81032-2	1	
40	Decal, Warning	015849	1	
41	Bolt, M6 x 20-8.8 Hex Head Full Thread Zinc	F81001-2	2	
42	Screw, 12/M10 x 20 12.9 ISO7379(BOSSARD) Socket Head Shoulder	F81003-68	2	
43	Mounting Block, LT70 Blade Guide, zinc	089503-1	1	
44	Bolt, Blade Guide Adjustment, zinc	506552-1	1	
45	Bolt, M8x25 DIN933 A2-70, Stainless	F81002-26	3	
46	Nut, M8 DIN934 A2-70, Stainless	F81032-7	5	
47	Washer, 8.4 FLAT,ZINC	F81054-1	7	
48	Bolt M8x40 DIN933 A2-70, Stainless	F81002-28	3	
49	Blade Guide Parts ( <a href="#">See Section 2.1</a> )	092997	1	
	<b>Chain, #25 x 92 PITCHES B/G</b>	<b>093805</b>	<b>1</b>	
50	Chain, #25 x 92 Pitches B/G	042443	1	
51	KETTENGLIED #25	P09983	1	

## 2 BLADE GUIDE ROLLERS & ARM

### Blade Guide Mount Assembly, Drive Side

#### 2.4 Blade Guide Mount Assembly, Drive Side

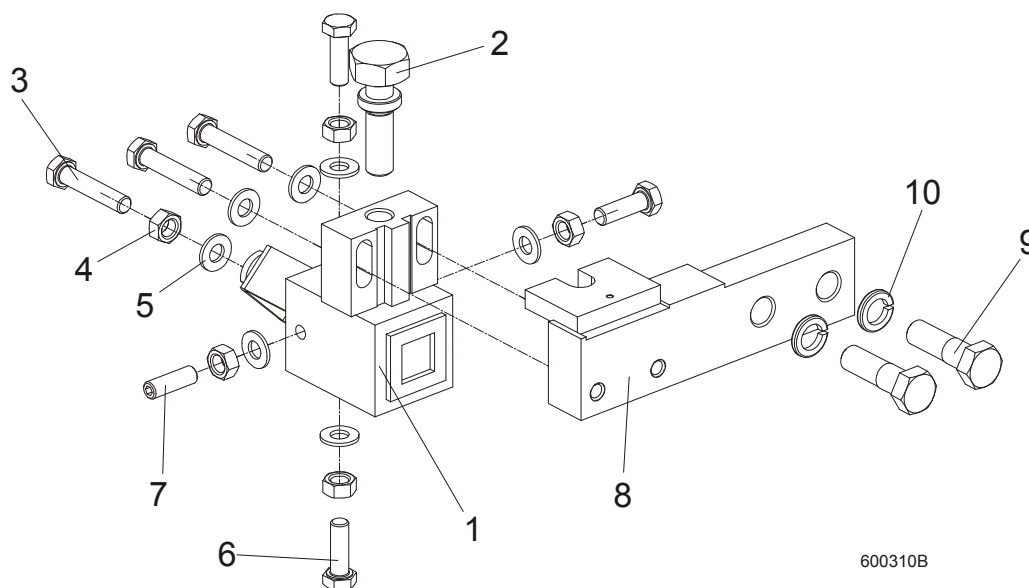

600310B

REF.	DESCRIPTION (◆ Indicates Parts Available In Assemblies Only)	PART#	QTY.
	<b>MOUNTING BLOCK, DRIVE SIDE</b>	091338	1
1	MOUNTING BLOCK, BLADE GUIDE, DRIVE SIDE, ZINC	089503-1	1
2	BOLT, BLADE GUIDE ADJUSTMENT, ZINC	506552-1	1
3	BOLT, M8X40 DIN933 A2-70, STAINLESS	F81002-28	3
4	NUT, M8 DIN934 A2-70, STAINLESS	F81032-7	5
5	WASHER, 8.4 FLAT,ZINC	F81054-1	7
6	BOLT, M8X25 DIN933 A2-70, STAINLESS	F81002-26	3
7	SCREW, BLADE GUIDE ADJUSTMENT, M8X25 A2-70 DIN 913, STAINLESS	F81014-3	1
8	BAR, BLADE GUIDE MOUNT, ZINC	089501-1	1
9	BOLT,M12X40-8.8 HEX HEAD ZINC	F81004-1	2
10	WASHER, M12 SPLIT LOCK ZINC	F81056-2	2

## SECTION 3 BLADE WHEELS & TENSIONER

### 3.1 Blade Drive Assembly

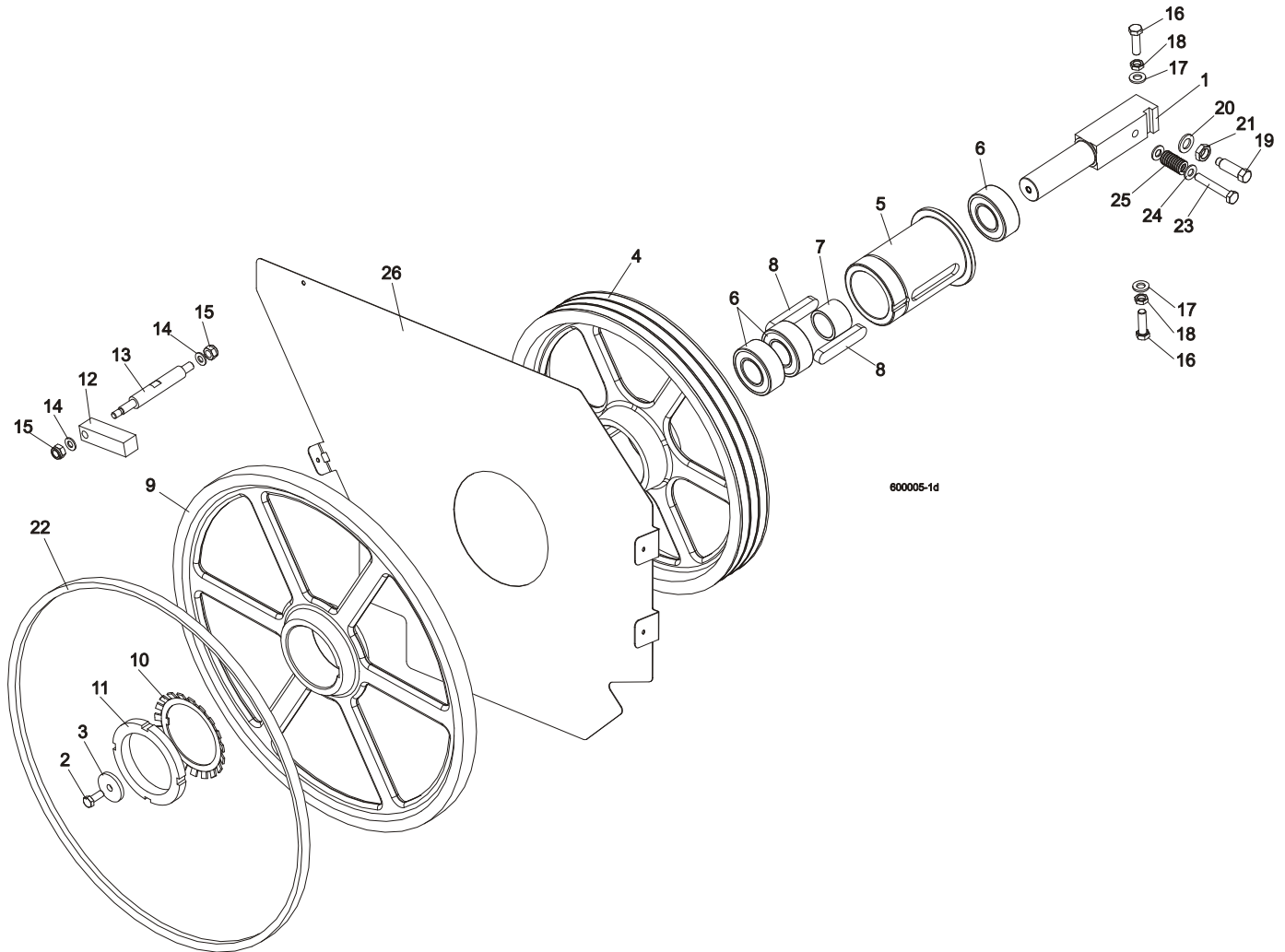

REF	DESCRIPTION (◆ Indicates Parts Available In Assemblies Only)	PART #	QTY.
1	SHAFT, BLADE DRIVE WHEEL	088475	1
2	BOLT, M10x25 8.8 HEX HEAD FULL THREAD	F81003-31	1
3	WASHER, BLADE DRIVE WHEEL	088956-1	1
	<b>PULLEY ASSEMBLY, BLADE DRIVE</b>	504808	1
4	Pulley, 3-Groove 484 mm Diameter	089457-1	1
5	Bushing, Blade Drive Wheel	504809	1
6	Bearing, 3208.2rsr.tvh (FAG) Rolling	088449	3
7	Spacer, 51x41x36.3 Drive Bearing	504810	1
8	Key, A20x12x100 Parallel	088477	2
9	<b>WHEEL, BLADE DRIVE</b>	090811	1
10	WASHER, MB21 (FAG) LOCK	088451	1
11	NUT, KM21(M105X2) (FAG) LOCK	088450	1
12	BAR, WHEEL SCRAPER	088781	1

# 3

## Blade Wheels & Tensioner

### Idle Blade Wheel Assembly

13	SHAFT, WHEEL SCRAPER	088780-1	1	
14	WASHER, 10.5 ZINC FLAT	F81055-1	2	
15	NUT, M12-8 HEX NYLON ZINC LOCK	F81034-2	2	
16	BOLT, M12X1.25X40 HEX HEAD	F81004-42	3	
17	WASHER, 13 FLAT ZINC	F81056-1	3	
18	NUT, M12X1.25 8.8 THIN ZINC	F81034-5	3	
19	SCREW, M16X1.5X50-33H HEX HEAD FULL DOG POINT SET ZINC	F81006-14	1	
20	WASHER, 17 ZINC FLAT	F81058-1	1	
21	NUT, M16x1.5-08-B ZINC THIN	F81036-6	1	
22	BELT, BLADE WHEEL B72.5	017922-1	1	
23	BOLT M10X65	F81003-67	1	
24	WASHER, 10.5 ZINC FLAT	F81055-1	2	
25	SPRING19X38	034430	1	
26	PLATE, LT70AC SAW HEAD (OPTION)	100897-1	1	
	BELT 3B/HB2462 La	089464	1	

### 3.2 Idle Blade Wheel Assembly

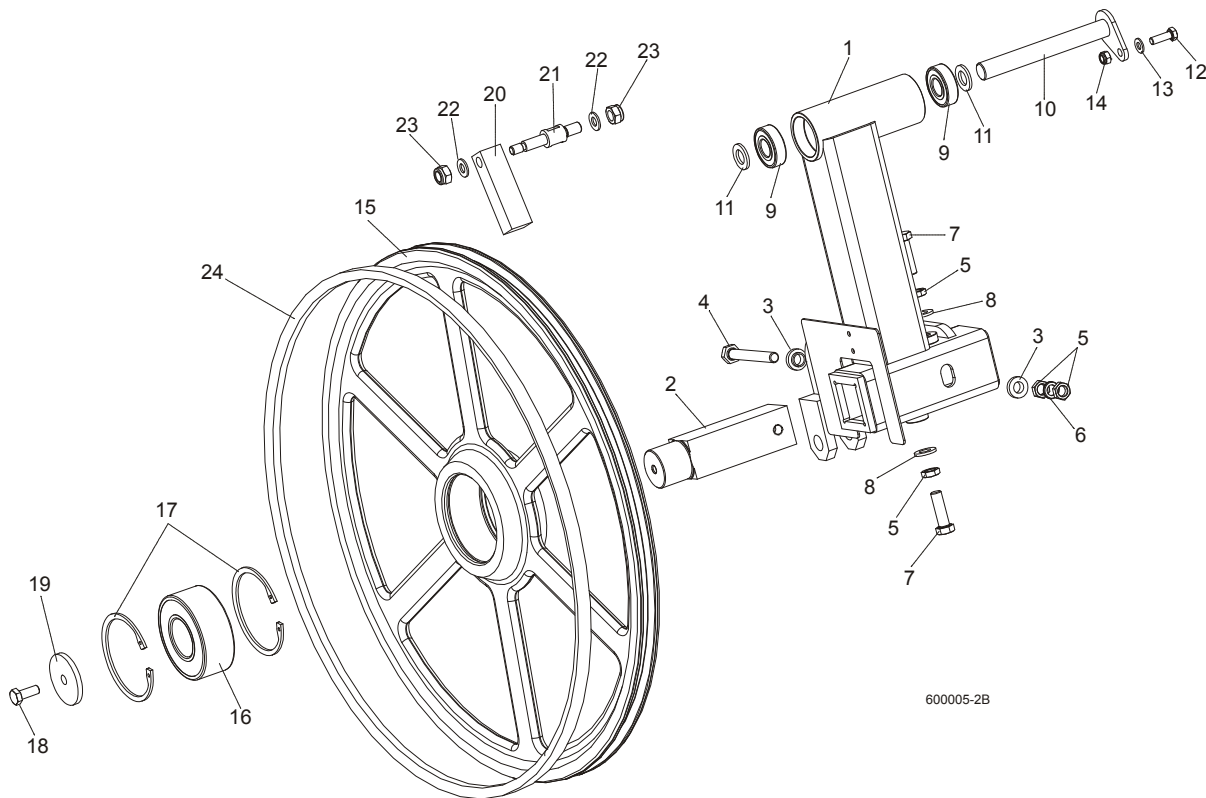

REF	DESCRIPTION (◆ Indicates Parts Available In Assemblies Only)	PART #	QTY.	
	<b>TUBE, LT70 IDLE SIDE BLADE WHEEL W/LEVER COMPLETE</b>	092791	1	
1	Tube Weldment, LT70 Idle Blade Wheel w/Lever	092780-1	1	
2	Shaft, Idle Blade Wheel	088474	1	
3	Washer, Zinc Special	086769-1	2	
4	Bolt, M12x1.25x100-8.8 Hex Head Zinc	F81004-41	1	
5	Nut, M12x1.25 8.8 Hex ZincThin	F81034-5	4	
6	Washer, Z12.2 Split Zinc Lock	F81056-2	1	
7	Bolt, M12x1.25x40 Hex Head	F81004-42	2	



8	Washer, 13 Zinc Flat	F81056-1	2	
9	Bearing, 6204 2RS-CX Rolling	088447	2	
10	<b>PIN WELDMENT, PIVOT</b>	088759-1	1	
11	<b>WASHER, 17 ZINC FLAT</b>	F81058-1	2	
12	<b>BOLT, M8X25-8.8-B HEX HEAD FULL THREAD ZINC</b>	F81002-5	1	
13	<b>WASHER, 8.4 ZINC FLAT</b>	F81054-1	1	
14	<b>NUT, M8-8-B HEX NYLON ZINC LOCK</b>	F81032-2	1	
	<b>WHEEL ASSEMBLY, IDLE SIDE</b>	088764	1	
15	Wheel, Blade Idle Side	090810	1	
16	Bearing, 3309B.2RSR.TVH-P66 FAG	086428	1	
17	Ring, W100 Spring Retaining	F81090-10	2	
18	<b>BOLT, M10X25 8.8 HEX HEAD FULL THREAD</b>	F81003-31	1	
19	<b>WASHER, IDLE BLADE WHEEL RETAINING</b>	088957-1	1	
20	<b>SCRAPER, IDLE BLADE WHEEL</b>	088781	1	
21	<b>SHAFT, SHORT ZINC WHEEL SCRAPER</b>	088779-1	1	
22	<b>WASHER, 10.5 ZINC FLAT</b>	F81055-1	2	
23	<b>NUT, M12-8 HEX NYLON ZINC LOCK</b>	F81034-2	2	
24	<b>BELT, BLADE WHEEL B72.5</b>	017922-1	1	

### 3.3 Hydraulic Blade Tensioner Assembly

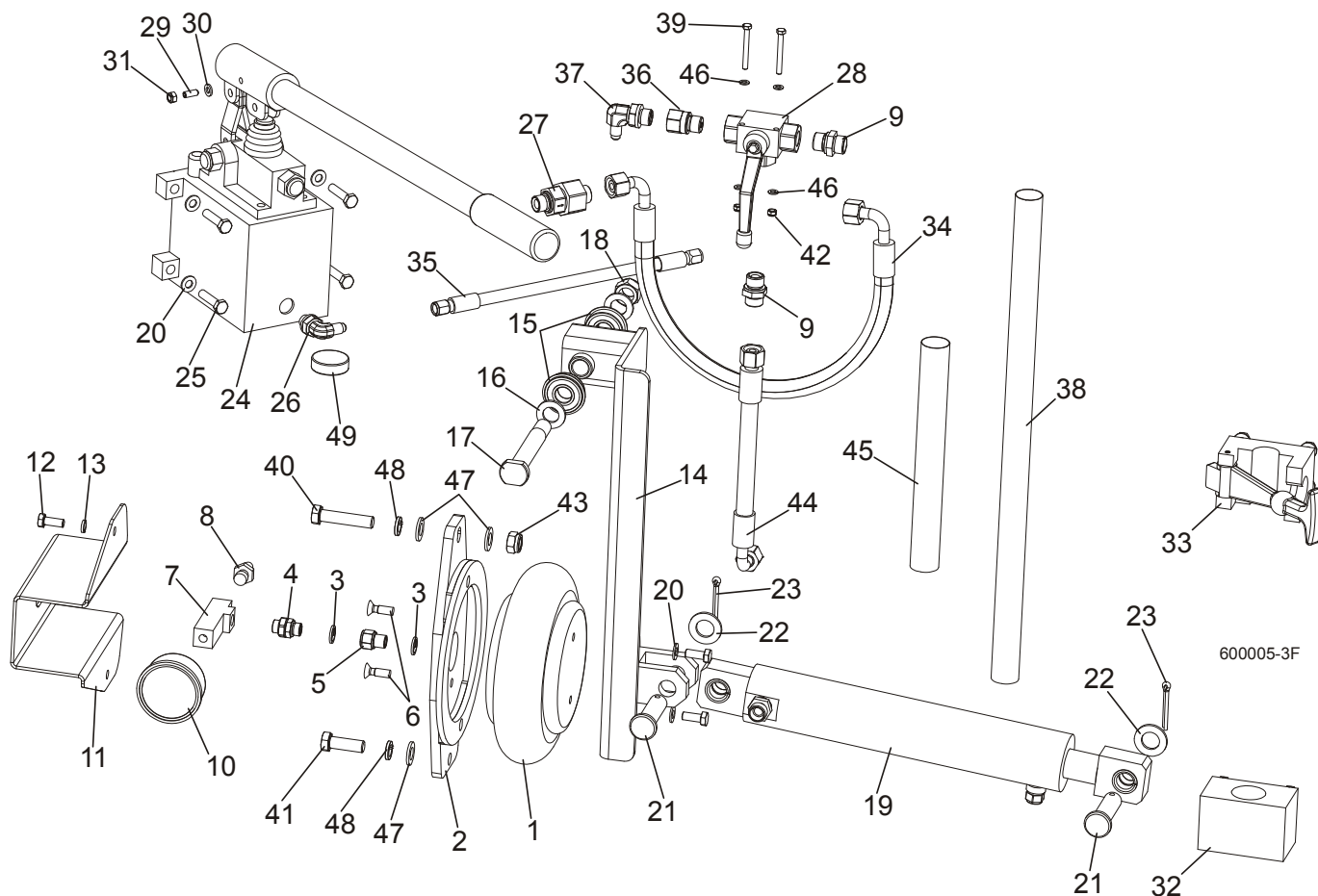

REF	DESCRIPTION (◆ Indicates Parts Available In Assemblies Only)	PART #	QTY.
	<b>HYDRAULIC BLADE TENSIONER, COMPLETE</b>	504801	1
1	BAG, POJ 192 308 100 0 AIR	088576	1
2	BRACKET, AIR BAG MOUNT	088798-1	1
3	SEAL, G1/4 866-014-000-0	090809	4
4	NIPPLE, 1/4 8632141400)BOSCH	097703	1
5	FITTING, 1/4 THREAD/1/4 THREAD 2521	097704	1
6	BOLT, M8X25 PAN HEAD ZINC	F81002-51	2
7	TEE CONNECTOR, SPECIAL	097702-1	1
8	FITTING, 1/4" THREAD 390 004 004 0 (REXROTH) AIR TANK VALVE	088575	1
9	FITTING, HD-GE-12L-BE-06 STRAIGHT	094561	2
10	GAUGE, M63T-2,5/20G G 1/8 0-0,6 MPA/PSI AIR PRESSURE	088568	1
11	GUARD, AIR PRESSURE GAUGE	088924-1	1
12	SCREW, M8X25 CROSS RECESSED COUNTERSUNK HEAD ZINC	F81002-4	4
13	WASHER 8.2 ZINC SPLIT	F81054-4	2
14	ARM, AIR CYLINDER PAINTED	092779-1	1
15	BEARING W/SNAP RING 6203-2RS	086395	2
16	WASHER, 17 FLAT ZINC	F81058-1	2
17	PIN, IDLER ARM MOUNT	086404	1
18	NUT, M16, HEX, NYLON ZINC LOCK	F81036-2	2

19	CYLINDER, HYDRAULIC COMPLETE	092788	1	
	CYLINDER, SHDJ050/030X80 HYDRAULIC	092787-1	1	
	BUSHING, TUF1 18x120 CX	500106	4	
	FITTING, HD-GE-12L-BE-06 STRAIGHT	094561	1	
	VALVE, 2901-14-17 AIR VENT	090794	1	
20	WASHER, 8.4 ZINC FLAT	F81054-1	6	
21	PIN, PN-EN 22341-B-18X65X57-A2	F81049-4	2	
22	WASHER, 19 FLAT ZINC	F81060-1	2	
23	PIN, S-ZN 5X40 PN-M/82001	F81043-31	2	
24	PUMP,PMS12/TNK1 MANUAL W/TANK 1L	092789-1	1	
25	BOLT, 8MM X 1.25X35MM HH ZINC	F81002-13	4	
26	ELBOW, CA-204410-3	094562	1	
27	VALVE, RHV12LREDA3C CHECK	094559	1	
28	VALVE, BALL 3-WAY RSAP3 VOL2L G3/8"	504803	1	
29	LATCH, GN615.3-M6-KN BALL THREADED	096874	1	
30	WASHER, M6, FLAT, ZINC	F81053-1	1	
31	NUT, M6, HEX, NYLON LOCK ZINC	F81031-2	1	
32	BRACKET, TENSIONER PUMP HANDLE BOTTOM	096951	1	
33	BRACKET, TENSIONER PUMP HANDLE UPPER	092800	1	
34	HOSE, DN10 W/FITTING 10AOL 90 M18X1.5	504804	1	
35	HOSE, 1/4 W/FITTING JIC 7/16-20	504805	1	
36	FITTING, G 3/8 THROTTLE	096849	1	
37	ELBOW, CA-204411-3	094563	1	
38	HOSE PROTECTION	505178	1	
39	BOLT, M5X45 DIN933 A2-70 STAINLESS STEEL	F81000-22	2	
40	BOLT, M12X55-8.8 HEX HEAD ZINC	F81004-12	1	
41	BOLT, M12 X 35-8.8-FE/ZN5 HEX HEAD FULL	F81004-24	1	
42	NUT, M5-8-FE/ZN5 DIN985	F81030-2	2	
43	NUT, M12-8 HEX NYLON ZINC LOCK	F81034-2	1	
44	HOSE, DN12 W/FITTINGS PN10AOL90 I PN10AOL M1.5	096964	1	
45	HOSE PROTECTION	098489	1	
46	WASHER, 5.3 FLAT ZINC	F81052-1	4	
47	WASHER, 13 FLAT ZINC	F81056-1	3	
48	WASHER, Z12.2 SPLIT LOCK ZINC	F81056-2	2	
49	MAGNET, MW.38X12/N38 NEODYMIUM	500022	1	

**3.4 Sawdust Flow Guide**

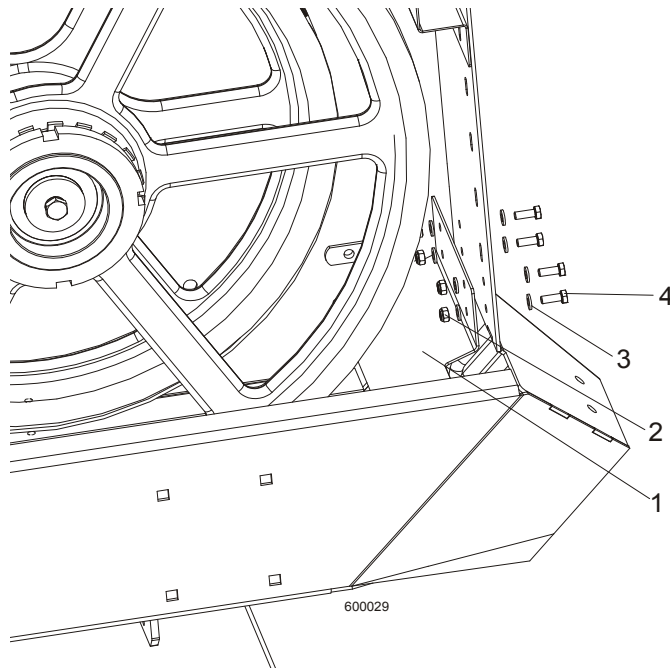

REF	DESCRIPTION (◆ Indicates Parts Available In Assemblies Only)	PART #	QTY.
1	GUIDE, SAWDUST FLOW PAINTED	090506	1
2	NUT, M6-8-B HEX NYLON ZINC LOCK	F81031-2	4
3	WASHER 6.4 ZINC FLAT	F81053-1	8
4	BOLT, M6 X 16 8.8 FE/ZN5 PN-M/82105	F81001-15	4

## SECTION 4 SAW HEAD

### 4.1 Middle Throat Screw

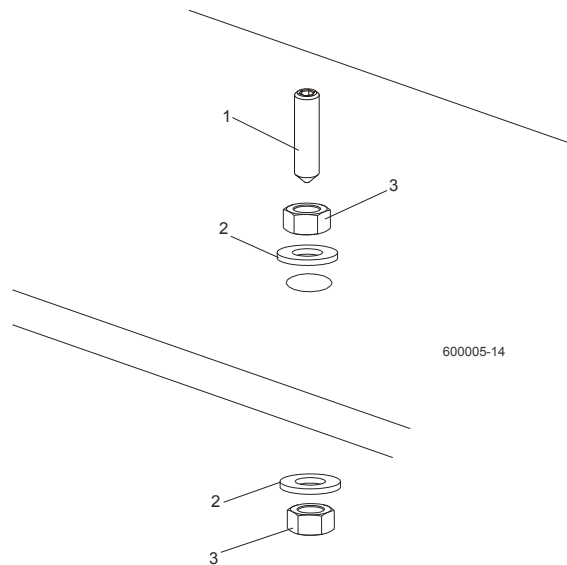

REF	DESCRIPTION (◆ Indicates Parts Available In Assemblies Only)	PART #	QTY.	
1	SCREW, M10X40-45H HEX SOCKET SET CONE POINT ZINC	F81003-61	1	
2	WASHER, 10.5 ZINC FLAT	F81055-1	2	
3	NUT, M10-8-B ZINC HEX	F81033-3	2	

### 4.2 Drive Belt Tensioner LT70 AC

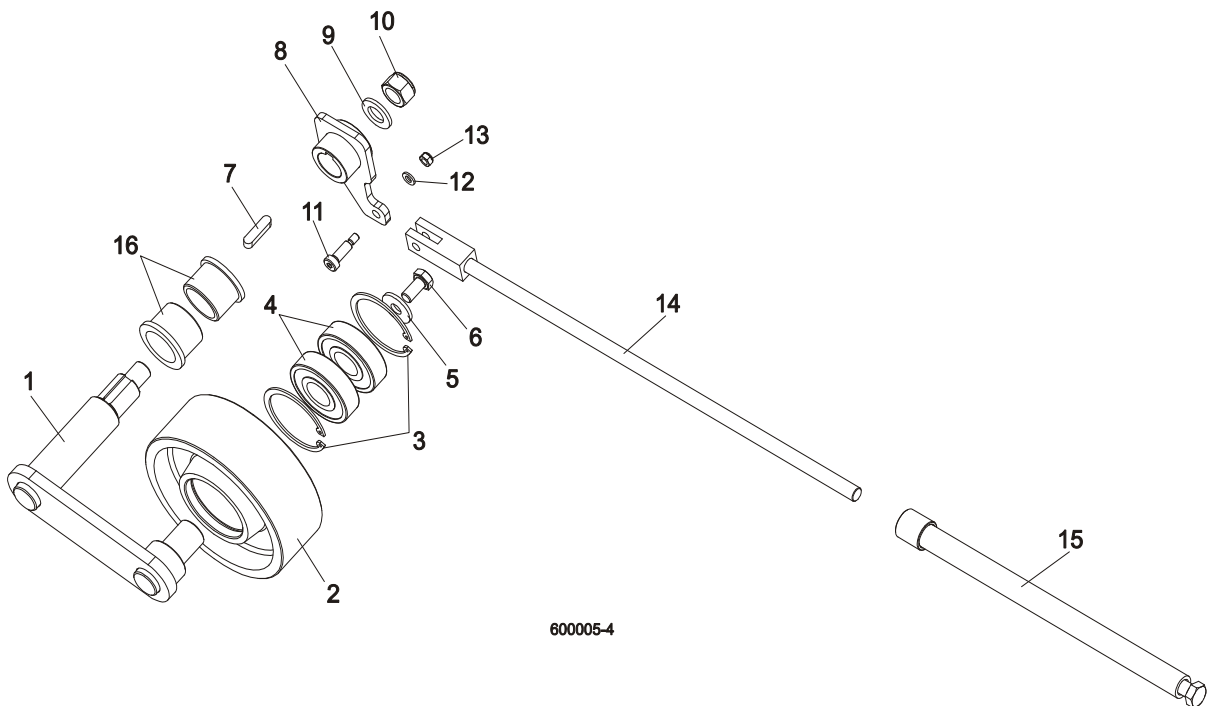

REF	DESCRIPTION (◆ Indicates Parts Available In Assemblies Only)	PART #	QTY.	
	TENSIONER ASSEMBLY, DRIVE BELT	508761	1	
1	Pivot Weldment, Drive Belt Tensioner	509885-1	1	

2	Wheel, Belt Tension	508762	1	
3	Ring, 62 mm Inside Spring Retaining	F81090-1	2	
4	Bearing, 6305 2RS NSK	P08066	2	
5	Washer, 11 Dia. Zinc Flat Special	088787-1	1	
6	Bolt, M10x20-5.8 Hex Head Full Thread Zinc	F81003-1	1	
7	Key, A8X7X32 Parallel	088564	1	
8	Arm Weldment, Drive Belt Tensioner	088807-1	1	
9	Washer, 17 Zinc Flat	F81058-1	1	
10	Nut, M16-5.8 Zinc Hex	F81036-2	1	
11	Bolt, 8/M6X20 12.9 ISO 7379 BOSSARD	F81001-25	1	
12	Washer 6.4 Zinc Flat	F81053-1	1	
13	Nut, M6-8-B Hex Nylon Zinc Lock	F81031-2	1	
14	Rod Weldment, Threaded Zinc-Plated	088789-1	1	
15	Tube Weldment, Threaded Zinc-Plated	088782-1	1	
16	<b>BUSHING, MFM-3240-30</b>	088461	2	

**4.3 Board Return Assembly (Optional)**

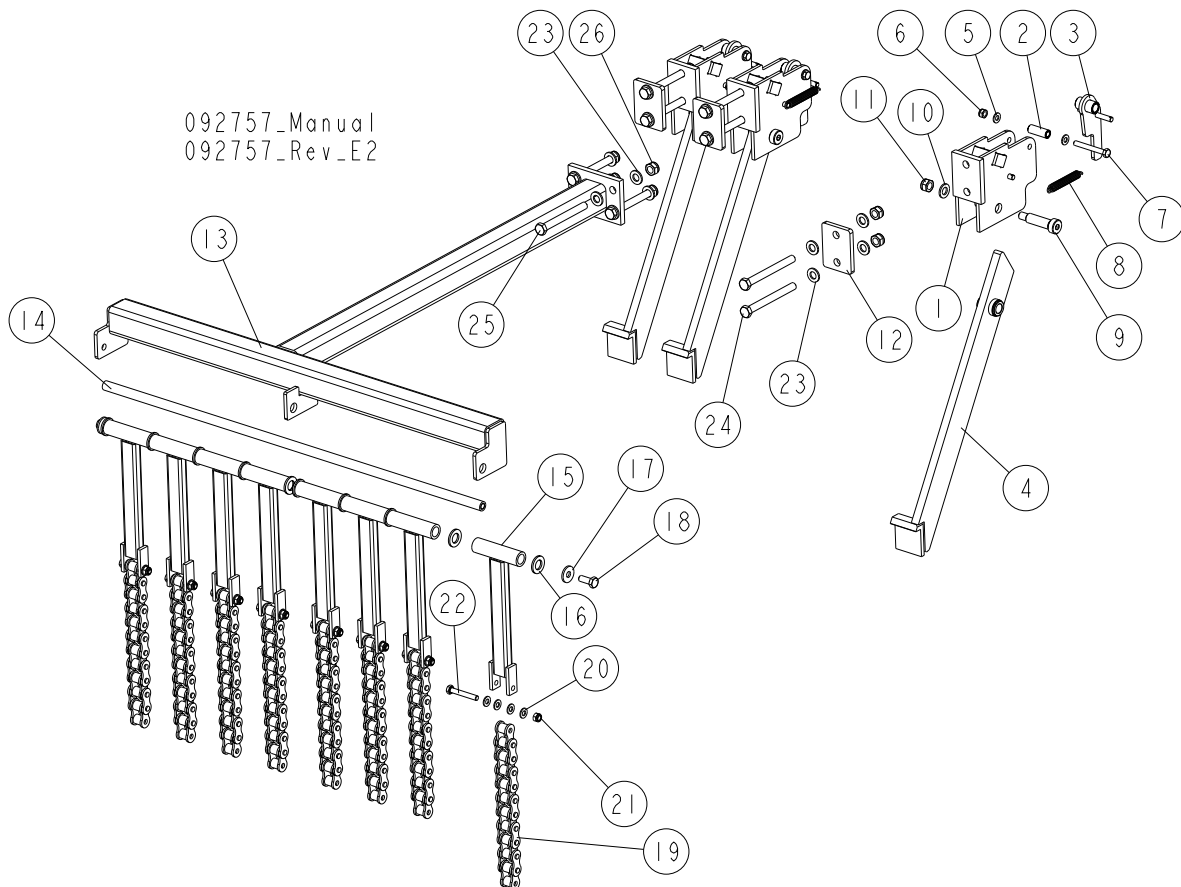

	DESCRIPTION (* Indicates Parts Available In Assemblies Only)	PART #	QTY	
	<b>BOARD RETURN ASSEMBLY</b>	<b>092757</b>	<b>1</b>	
	<b>BOARD, RETURN ASSEMBLY</b>	<b>090120</b>	<b>3</b>	
1	MOUNT WELDMENT, BOARD RETURN ARM	090109-1	1	

	DESCRIPTION (* Indicates Parts Available In Assemblies Only)	PART #	QTY	
2	SPACER, ZINC	090115-1	1	
3	LATCH WELDMENT, BOARD RETURN ARM	090118-1	1	
4	ARM, BOARD RETURN	090112-1	1	
5	WASHER, 8.4 FLAT ZINC	F81054-1	2	
6	NUT, M8-8-B HEX NYLON ZINC LOCK	F81032-2	1	
7	BOLT, M8 X 65MM,HH,GRADE 5.8, ZINC	F81002-3	1	
8	SPRING, EXT 1/2X2 1/4X.06	014817	2	
9	BOLT, 16/M12X50-12.9 ISO7379-BOSSARD SOCKET HEAD	F81004-25	1	
10	WASHER, 13 FLAT ZINC	F81056-1	1	
11	NUT, M12-8 HEX NYLON ZINC LOCK	F81034-2	1	
12	WASHER, SPECIAL	092756-1	3	
	<b>GUIDE, BOARD RETURN</b>	<b>514162</b>	<b>1</b>	
13	GUIDE WELDMENT, BOARD RETURN	091067-1	1	
14	ROD, BOARD RETURN GUIDE	091074	1	
15	BAR WELDMENT, BOARD GUIDE UPPER	091070-1	8	
16	WASHER, 17 FLAT ZINC	F81058-1	10	
17	WASHER,10.5 ZINC FLAT SPECIAL	F81055-6	2	
18	BOLT, M10 X 25 8.8 FE/ZN5, PN-M/82105	F81003-31	2	
19	CHAIN 16B-1 - 0.28M	514163	8	
20	WASHER, 8.4 FLAT ZINC	F81054-1	32	
21	NUT, M8-8-B HEX NYLON ZINC LOCK	F81032-2	8	
22	BOLT, M8 X 55 8.8 FE/ZN5, PN-M/82101	F81002-8	8	
23	WASHER, 13 FLAT ZINC	F81056-1	20	
24	BOLT M12X120 8.8 FE/ZN5	F81004-38	6	
25	BOLT,M12X110-8.8-B-FE/ZN5 PN-85/M82101	F81004-47	4	
26	NUT, M12-8 HEX NYLON ZINC LOCK	F81034-2	10	

4.4 Water Lube Assembly

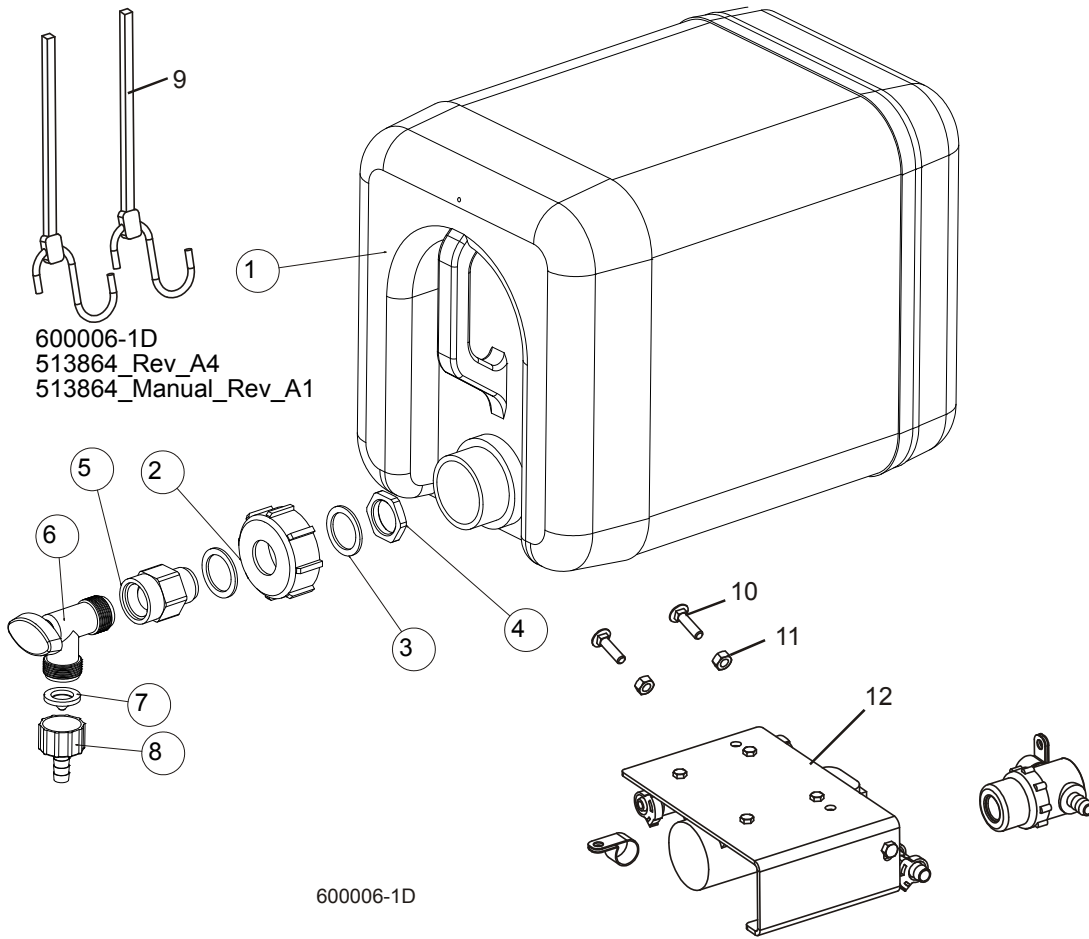

REF	DESCRIPTION (◆ Indicates Parts Available In Assemblies Only)	PART #	QTY.
	<b>BOTTLE, WATER, COMPLETE.</b>	<b>513864</b>	<b>1</b>
	<b>BOTTLE, WATER, WITH NUT.</b>	<b>513865<sup>1</sup></b>	<b>1</b>
1	BOTTLE, WATER	513866	1
2	NUT, BOTTLE.	513867	1
3	SEAL, RUBBER 35x26x2.	513869	2
4	NUT, PACKING 3/4 NPT.	513868	1
5	Fitting, 3/4FPT x 3/4MPT Reducer	014636	1
6	Fitting, Water Lube Shutoff Valve	014100	1
7	Filtr NUT	016086	1
8	FITTING, 5/8" NPT TO 3/8" HOSE BARB	014113	1
9	<b>STRAP, 20" RUBBER</b>	P11668	2
10	<b>BOLT, 1/4-20 X 1" CARRIAGE HEAD</b>	F05005-34	2
11	<b>NUT, 1/4-20 HEX LOCK</b>	F05010-21	2
12	<b>LUBEMIZER PARTS/HOSES (SEE LUBEMIZER OPTION MANUAL)</b>		

<sup>1</sup> The service number 513865-S includes: 513865, 513869, 513868



## 4.5 LT70AC Saw Head Decals

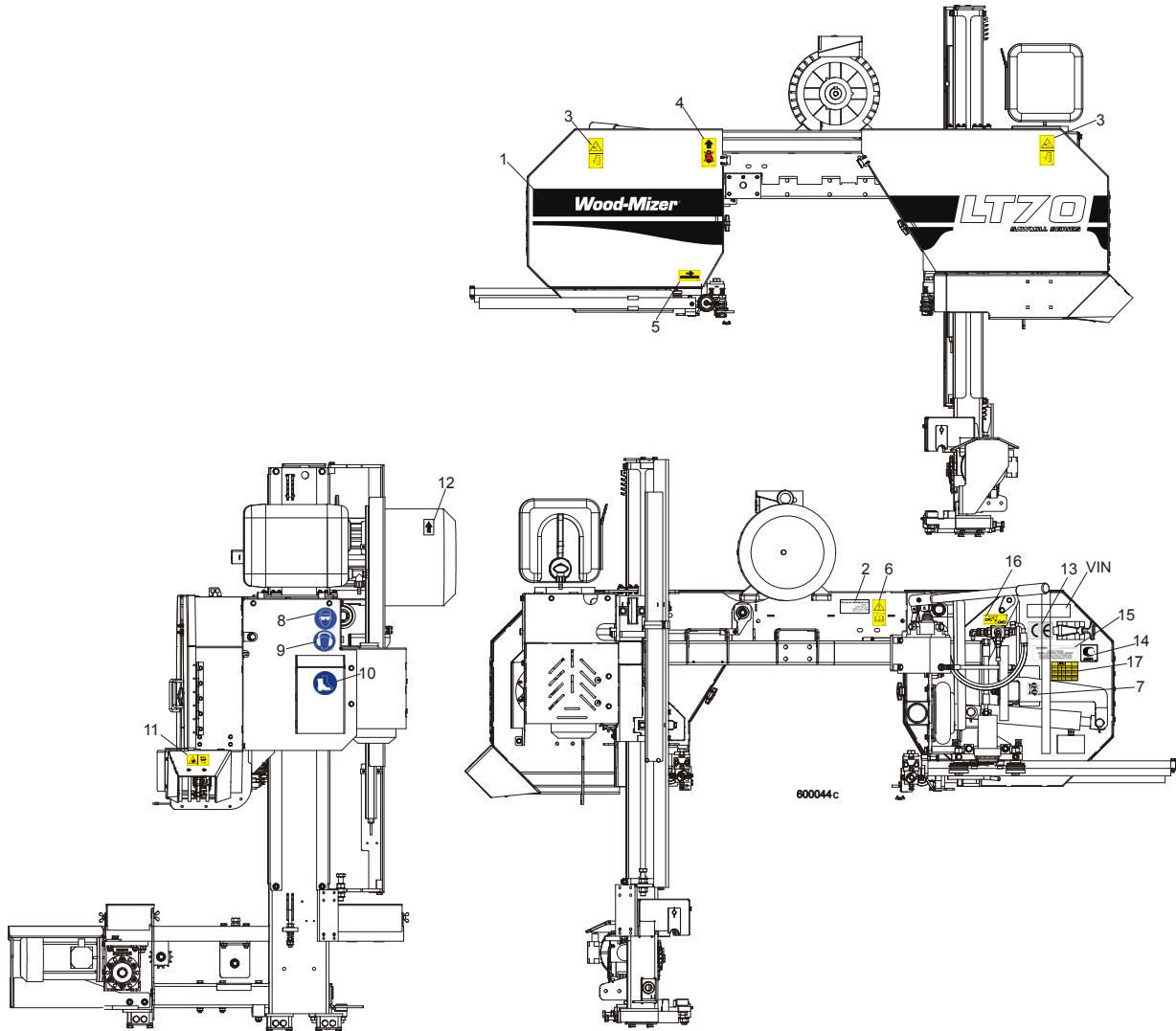

REF	DESCRIPTION (◆ Indicates Parts Available In Assemblies Only)	PART #	QTY.
1	<b>DECAL, LT70 SERIES SAWMILL</b>	092764	1
	<b>PICTOGRAPHIC DECAL KIT, LT70AC</b>	099518	1
2	DECAL, EUROPEAN HEADQUARTERS ADDRESS	015841	1
3	DECAL, SAWMILL COVERS CAUTION (PICTOGRAM)	099220	2
4	DECAL, PICTOGRAM (BLACK ARROW & HOOK)	085977B	1
5	DECAL, BLADE MOVEMENT DIRECTION (PICTOGRAM)	096321	1
6	DECAL, READ OPERATOR'S MANUAL (PICTOGRAM)	096317	1
7	DECAL, BLADE ALIGNMENT (PICTOGRAM)	P11789-70	1
8	DECAL, EYE PROTECTION WARNING (PICTOGRAM)	S12004G	1
9	DECAL, EAR PROTECTION WARNING (PICTOGRAM)	S12005G	1
10	DECAL, USE SAFETY BOOTS (PICTOGRAM)	501465	1
11	DECAL, SAWDUST CHUTE WARNING (PICTOGRAM)	099222	1
12	DECAL, MOTOR ROTATION DIRECTION	S20097	1
13	DECAL, CE CERTIFIED SAWMILL	P85070	2
14	DECAL, RUSSIAN SAFETY CERTIFICATION	099401	1

**4****SAW HEAD***LT70AC Saw Head Decals*

---

<b>15</b>	DECAL, INTERNATIONAL SAWMILL NAME	501466	1	
<b>16</b>	DECAL, LEVER OF TENSIONER'S BALL VALVE	505189	1	
<b>17</b>	DECAL, BLADE TENSION VALUES	518439	1	
	DECAL, HIGH VOLTAGE INSIDE THE ELECTRIC BOX (PICTOGRAM)	096316	2	
	DECAL, REMOVE THE PLUG BEFORE OPENING THE BOX (PICTOGRAM)	096319	2	
	DECAL, STAY A SAFE DISTANCE FROM THE BLADE (FOR DEBARKERS)	098176	1	
	DECAL, BLADE SETTING	P85066-70	1	
	DECAL, KEEP AWAY DANGER, PICTOGRAM	099221	1	
	DECAL, MAX. OIL PRESSURE, PICTOGRAM	099524	1	

## 4.6 Blade Housing Covers

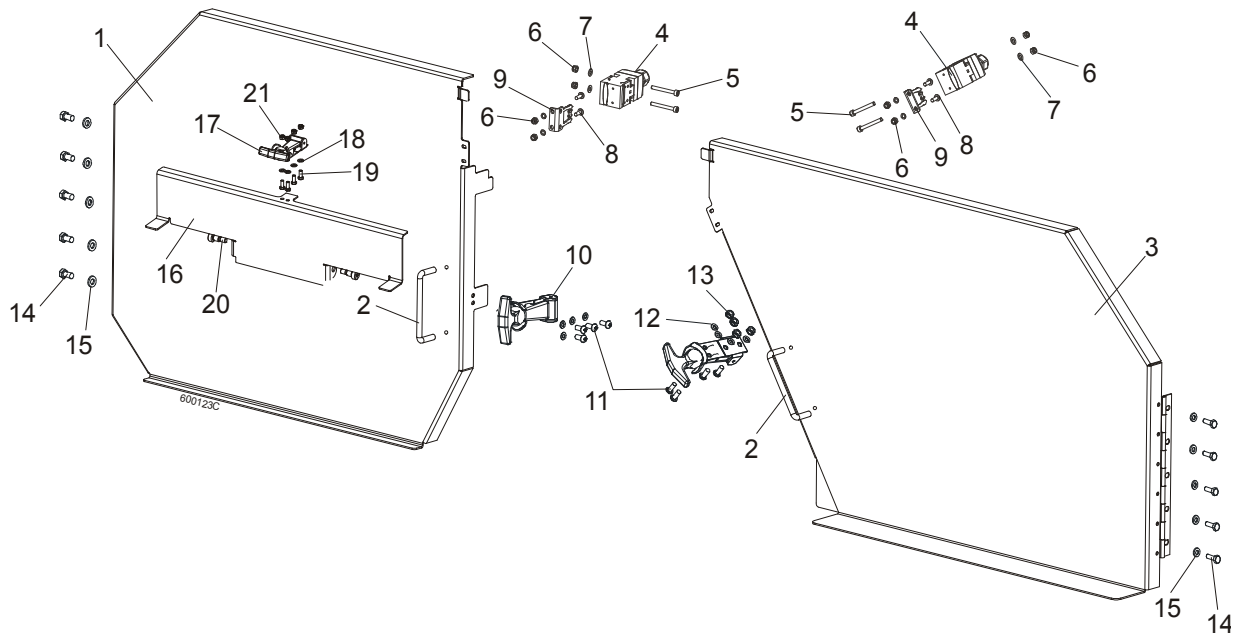

REF	DESCRIPTION (◆ Indicates Parts Available In Assemblies Only)	PART #	QTY.
	<b>COVER ASSEMBLY, IDLE SIDE BLADE HOUSING</b>	088920	1
1	Cover Assembly, Idle Side Blade Housing, Ptd	088915-1	1
2	Handle, Blade Housing Cover	P08065	1
	<b>COVER ASSEMBLY, DRIVE SIDE BLADE HOUSING</b>	088921	1
3	Cover Assembly, Drive Side Blade Housing, Ptd	088917-1	1
2	Handle, Blade Housing Cover	P08065	1
4	<b>LIMIT SWITCH, HONEYWELL GKMB 23W2</b>	086681	2
5	<b>BOLT, M4 X 35-8.8 SOCKET HEAD</b>	F81011-34	4
6	<b>NUT, M4-B HEX NYLON ZIN</b>	F81028-2	8
7	<b>WASHER 4,3 ZINC, FLAT</b>	F81051-2	8
8	<b>SCREW, M4 X 12-5.8</b>	F81011-41	4
9	<b>KEY, AZ17/170-B5 SAFETY SWITCH</b>	094422	4
10	<b>LATCH, FLEXIBLE DRAW</b>	014829	2
11	<b>BOLT, M5X12-5.8</b>	F81000-5	8
12	<b>WASHER 5,3 ZINC FLAT</b>	F81052-1	8
13	<b>NUT M5-8 DIN 985 ZINC</b>	F81030-2	8
14	<b>BOLT, M6X16 8.8 HEX HEAD FULL THREAD ZINC</b>	F81001-15	10
15	<b>WASHER 6.4 ZINC FLAT</b>	F81053-1	10
	<b>COVER BLADE UP LT70, COMPLETE</b>	<b>511536<sup>1</sup></b>	<b>1</b>
16	PLATE UP COVER LT70, PAINTED	511802-1	1
17	Latch, Flexible Draw	014829	1
18	WASHER 5.3 FE/ZN5 PN-78/M-82005	F81052-1	2
19	BOLT, M5 X 12-5.8-Fe/Zn5, PN-M/82105	F81000-5	4
20	BOLT, 10/M8 X 12-12.9 ISO-7379	F81003-62	2
21	NUT, M5-8-Fe/Zn5 DIN985	F81030-2	2

<sup>1</sup> Belongs to 088771 and 88770

**4.7 Sawdust Chute**

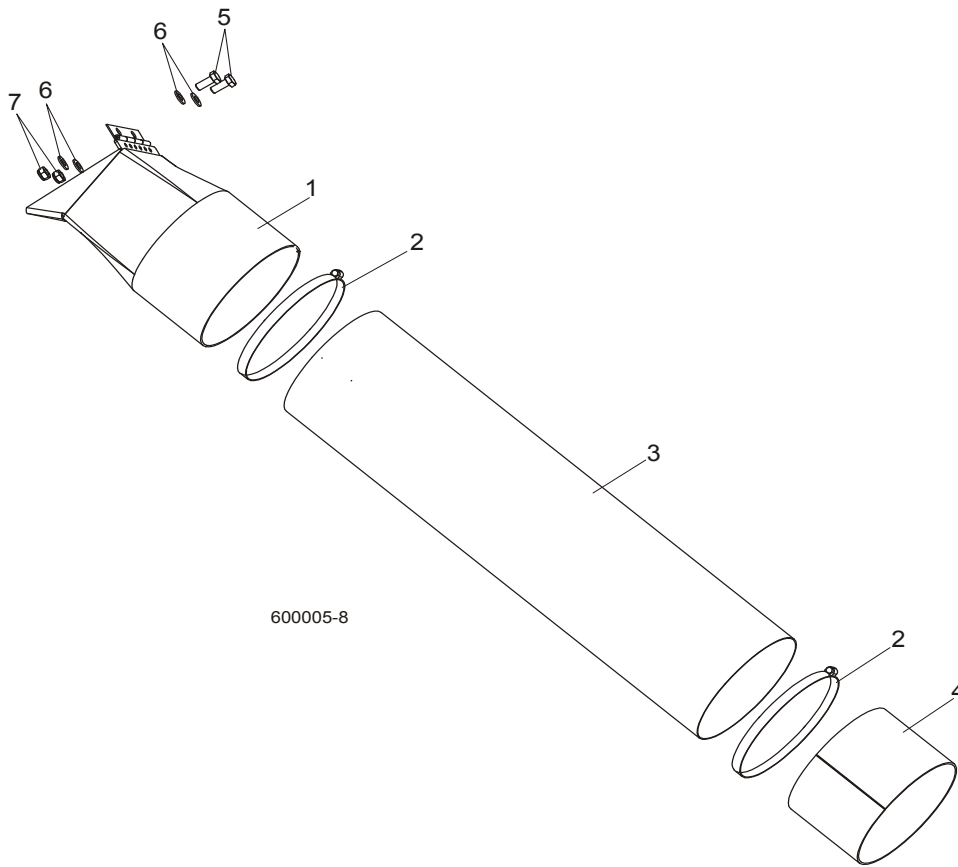

REF	DESCRIPTION (◆ Indicates Parts Available In Assemblies Only)	PART #	QTY.
1	CHUTE WELDMENT, SAWDUST	089352-1	1
2	CLAMP, 152 MM	089358	2
3	TUBE, SAWDUST CHUTE	090153	1
4	TUBE, CHUTE END	090126-1	1
5	BOLT, M8X20-8.8-B HEX HEAD FULL THREAD ZINC	F81002-4	2
6	WASHER 8.4 ZINC FLAT	F81054-1	4
7	NUT, M8-8-B HEX NYLON ZINC LOCK	F81032-2	2

4.8 Saw Head Protection Kit, LT70L Mobile

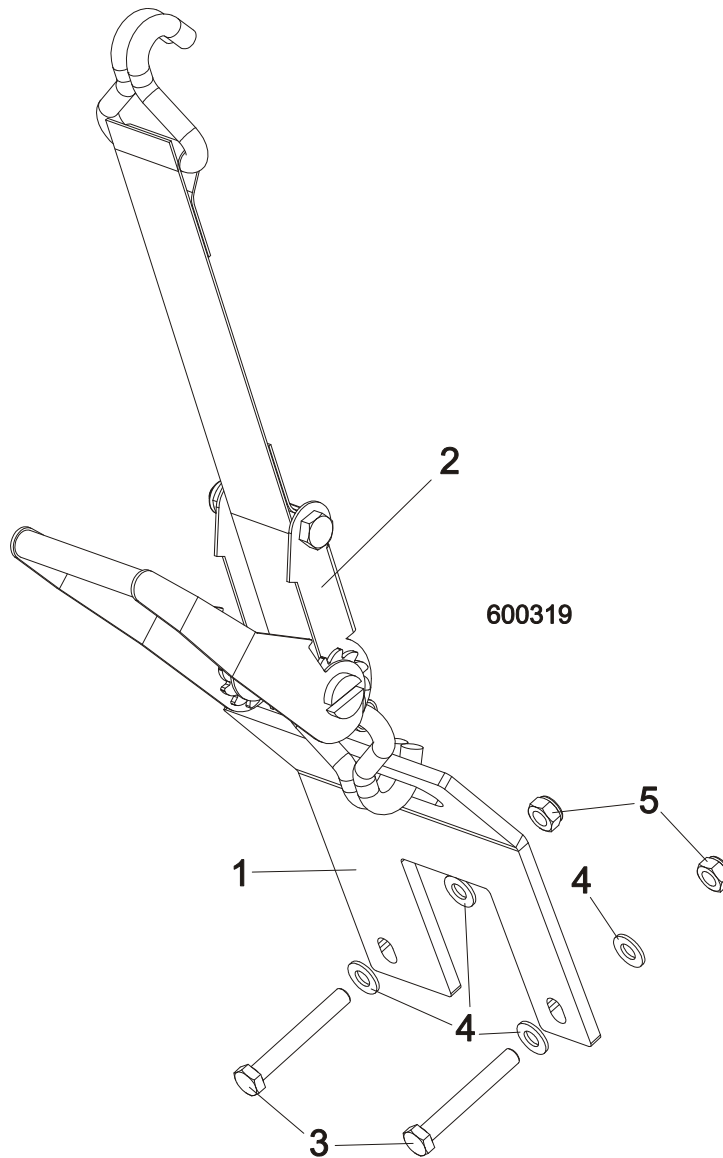

REF	DESCRIPTION (◆ Indicates Parts Available In Assemblies Only)	PART #	QTY.
	<b>SAW HEAD PROTECTION KIT, LT70L MOBILE</b>	505565	1
1	BRACKET, PROTECTION BELT-PAINTED	505549-1	1
2	BELT, LT70 SAW HEAD PROTECTION	505563	1
3	BOLT, M10x75-8.8-Fe/Zn5 PN-M/82101	F81003-15	2
4	WASHER, 10.5 FLAT ZINC	F81055-1	4
5	NUT, M10-8-B NYLON HEX ZINC LOCK	F81033-1	2

## SECTION 5 CONTROL BOXES

### 5.1 Control Assembly, LT70 AH

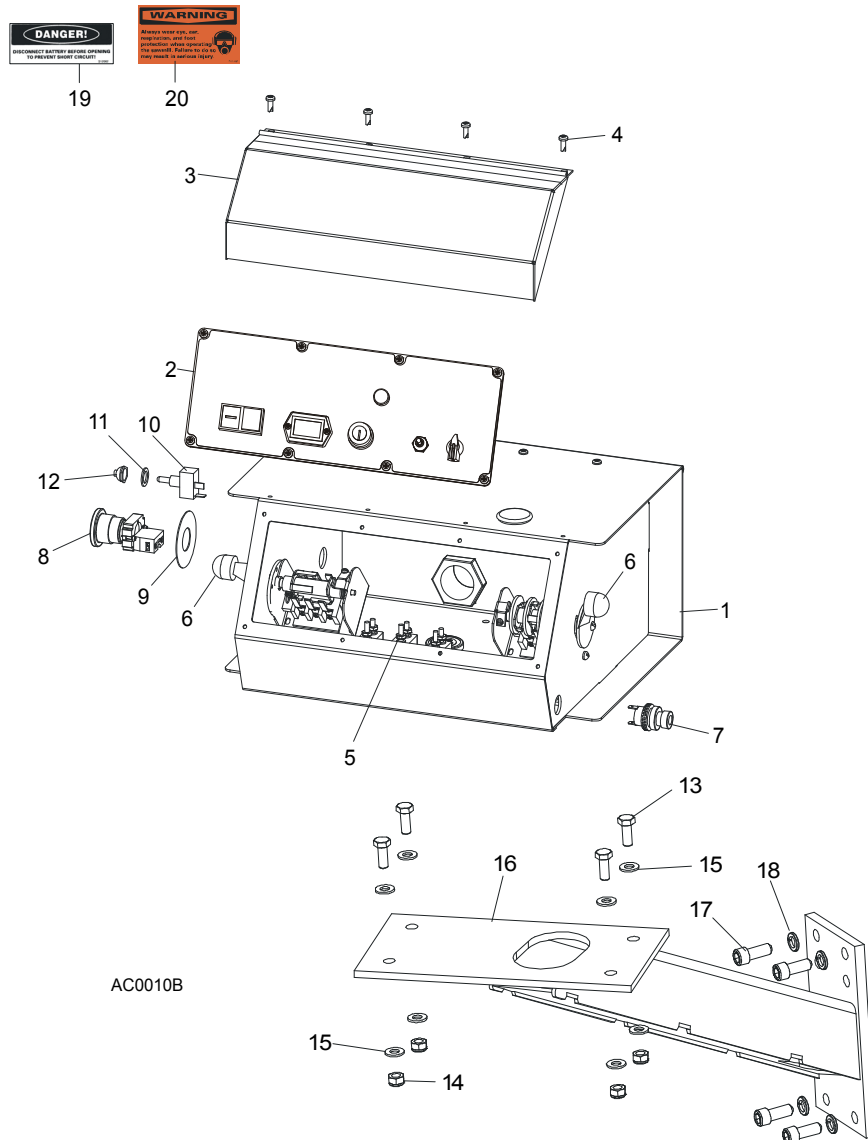

REF	DESCRIPTION (◆ Indicates Parts Available In Assemblies Only)	PART #	QTY.	
	<b>CONTROL BOX ASSEMBLY, AC SUPER (EA20, EA25)</b>	093022	1	
<b>1</b>	<b>HOUSING, AC SUPER CONTROL BOX ASSEMBLY (EA20, EA25)</b>	086546-1	1	◆
<b>2</b>	Front Control Panel & Wiring Harnesses ( <a href="#">Section 5.5</a> )			
<b>3</b>	Cover, Control Box Hinged	015304	1	
<b>4</b>	Screw, #10-24 x 1/2"	F05015-17	12	
<b>5</b>	Circuit Breakers ( <a href="#">Section 5.3</a> )			
<b>6</b>	Drum Switches ( <a href="#">Section 5.2</a> )			
<b>7</b>	Switch, Horn	E85118	1	
<b>8</b>	Switch, XB2 BS542 Emergency Stop	086556	1	
<b>9</b>	Washer, Emergency Stop Switch	086561	1	
<b>10</b>	Switch, Speed Control	086773	1	

11	Washer, 1/2" x 3/4" x 5/8" Nylon	P05251-1	1	
12	Boot, Speed Control Switch	P02575	1	
13	<b>BOLT, M8 X 20-8.8-B HEX HEAD</b>	F81002-4	4	
14	<b>NUT, M8-8-B HEX</b>	F81032-2	4	
15	<b>WASHER, 8.4 FLAT</b>	F81054-1	8	
16	<b>MOUNT WELDMENT, STANDARD CONTROL BOX</b>	086732-1	1	
17	<b>BOLT,, 3/8-16 X 1" SOCKET HEAD</b>	F05007-52	4	
18	<b>WASHER, 10.2 SPLIT LOCK</b>	F81055-2	4	
19	<b>DECAL, FRONT OUTRIGGER WARNING</b>	015400-4	1	
20	<b>DECAL, EAR/EYE PROTECTION WARNING</b>	S11753-4	1	

## 5.2 Control Assembly, LT70-RSW

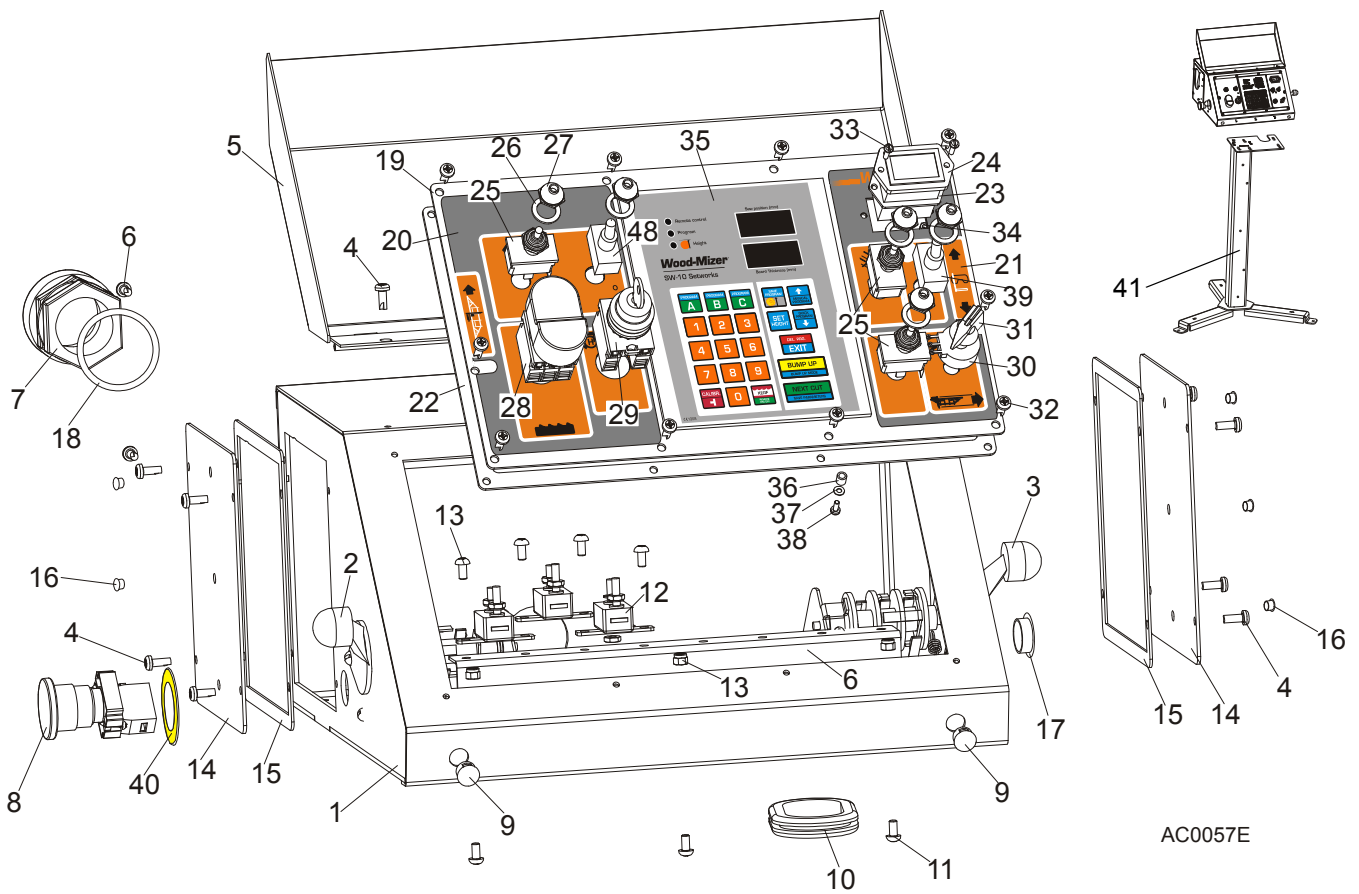

REF	DESCRIPTION (◆ Indicates Parts Available In Assemblies Only)	PART #	QTY.
	<b>CONTROL BOX ASSEMBLY, LT40 AC, LT70-RSW</b>	<b>098690</b>	<b>1</b>
	<b>CONTROL BOX ASSEMBLY, LT40 AC-RC</b>	<b>509115</b>	<b>1</b>
1	Control Box, LT40AC	099622-1	1
2	Switch, 1992GS Pwr/Feed (Service Package)	E20438	1
3	Switch, 1992 Up/Down (Service Package)	E20440	1
4	Bolt, #10-24x1/2 Ph Pan Hd, Type 23	F05015-17	12
5	Cover Weldment, LT20/40 Complete	097135-1	1
6	Rail, Circuit Breaker	015310	1
7	Connector, 1 1/4 Straight Metal Conduit	024402	1

8	Switch, XB2 BS542 Emergency	086556	1	
9	Switch, Speed Control	086773	2	
10	Grommet, Rubber	087065	1	
11	Screw, H M5x10 8.8 Zinc	F81000-13	7	
12	Breaker, 15A Manual Reset	E20430	3	
13	Nut, M5-8 Zinc	F81030-2	3	
	Cover, Control Box Side Complete	086700	2	
14	Cover, Control Box Side	086699-1	1	
15	Gasket, Control Box Side	015274	1	
16	Cap, SR1086 6.4 Dia. Hole	099700	6	
17	Cap, SR1086 22.2 Dia. Hole	093544	1	
18	Seal, 1 1/4 Ring LQTI w/Retainer	015430	1	
	Panel, LT40 AC Front Control Complete	098689	1	
19	Panel, LT20/40 AC Front Control	100572-1	1	
	Panel, LT40 AC Front Control	098586-1 <sup>1</sup>	1	
20	Decal, LT20/40 AC Control Box Left	099594	1	
21	Decal, LT40 DC Control Box Right	099596	1	
22	Gasket, LT20/40 Control Box	097132	1	
23	Gasket, Hour Meter	093346	1	
24	Meter, Hour	093166	1	
25	Switch, Toggle	024200	3	
26	Washer, 1/2x3/4x1/16 Nylon	P05251-1	5	
27	Boot, Toggle Switch	P02575	5	
28	Button, 24V Start/Stop	090452	1	
	Membrane M22-T-DD	090462	1	
29	Switch, M22 3-position Key	091361	1	
30	Potentiometer, 1k Feed Rate	E20519	1	
31	Knob, Speed Control	P06257	1	
32	Bolt, #10-24x1/2 Ph Pan Hd, Type 23	F05015-17	10	
33	Bolt, M3x12-8.8 Zinc	F81000-12	2	
34	Nut, M3-6 Nylon Zinc Lock	F81028-2	2	
35	Controller, SW-10 Setworks	500628	1	
36	Spacer, 4.2x6mm Idler	R80671-4	6	
37	Washer, 3.2 Flat Zinc	F81050-2	6	
38	Screw, M3x8-4.8 Zinc	F81000-83	6	
39	Switch, SPST On/Off 15A .25 TABS Toggle	P03027	2	
40	EMERGENCY STOP DECAL	086793	1	
41	STAND CONTROL BOX LT20/40/LES/EG300/TVS	501651-1 <sup>2</sup>	1	

<sup>1</sup> Use in African version only.

<sup>2</sup> Used In **509115**



### 5.3 Drum Switches

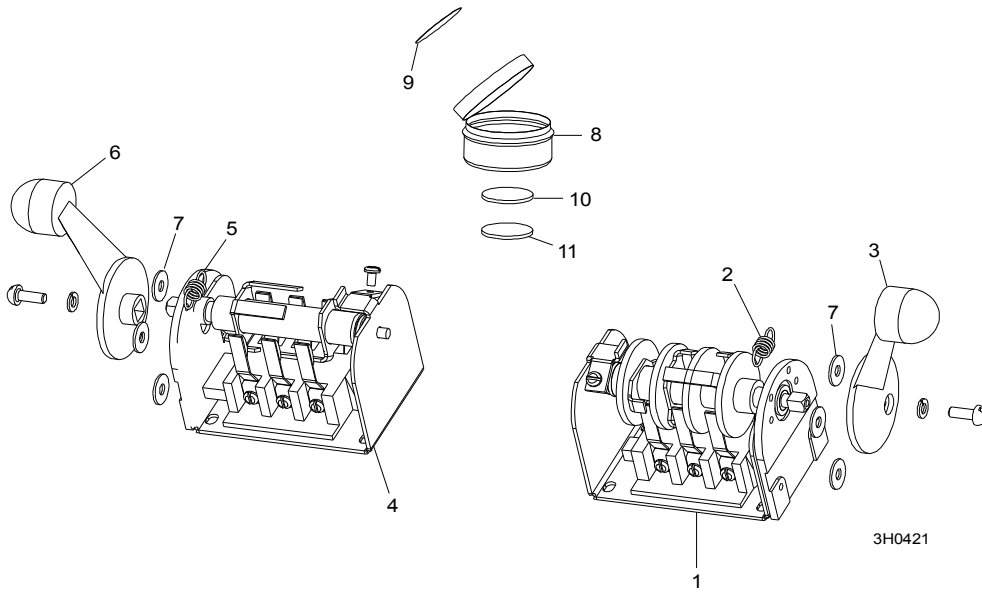

REF	DESCRIPTION (◆ Indicates Parts Available In Assemblies Only)	PART #	QTY.	
	<b>SWITCH ASSEMBLY, UP/DOWN DRUM</b>	E20440	1	
1	Switch, S12 Bulk Drum	E20440-B	1	◆
2	Spring, Drum Switch	P12570	1	
3	Handle, Drum Switch Replacement	P12500	1	
	<b>SWITCH ASSEMBLY, POWER FEED DRUM</b>	E20438	1	
4	Switch, S10 Bulk Drum	E20438-B	1	◆
5	Spring, Drum Switch	P12570	1	
6	Handle, Drum Switch Replacement	P12500	1	
7	<b>WASHER, #8 SAE FLAT</b>	F05011-41	6	
	<b>CUP ASSEMBLY, DRUM SWITCH GREASE</b>	A20463	1	
8	Cup, Plastic Container	P20464	1	◆
9	Decal, Grease Cup Label	P20467	1	
10	Pad, Velcro Loop	P20466	1	◆
11	Pad, Velcro Hook	P20465	1	◆
	Grease, High Temp Drum Switch	P20468	.011ml	◆

### 5.4 Circuit Breakers

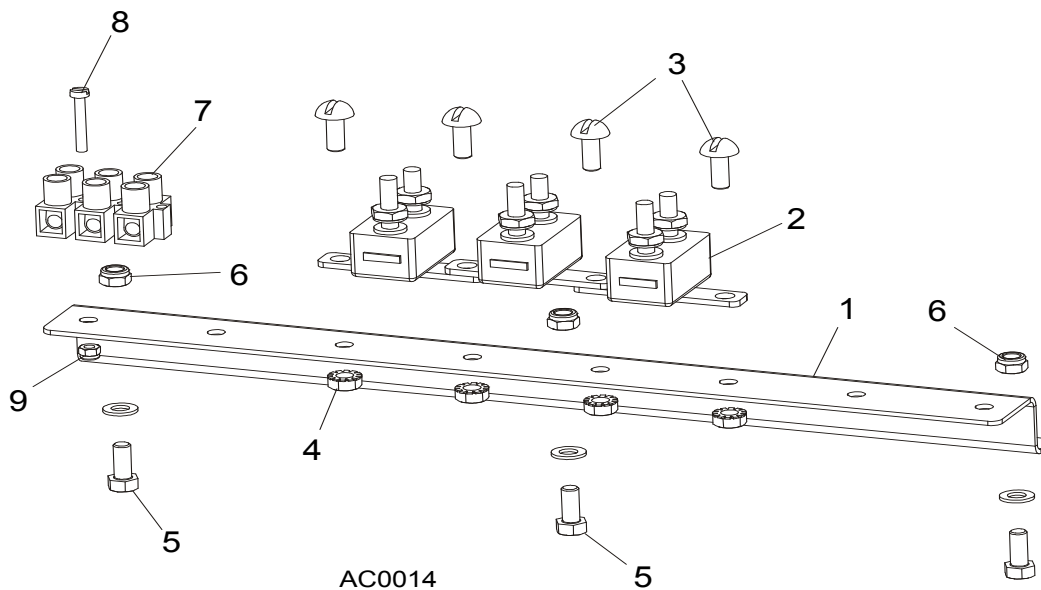

REF	DESCRIPTION (◆ Indicates Parts Available In Assemblies Only)	PART #	QTY.
	<b>BREAKER ASSEMBLY, SAWMILL CONTROL CIRCUIT</b>	015621	1
1	Rail, Circuit Breaker	015310	1
2	Breaker, 15 Amp Manual Reset	E20430	5
3	Screw, #8-32 X 1/2" Slotted Head	F05004-12	6
4	Nut, #8-32 Hex Self-Locking	F05010-41	6
5	<b>BREAKER, 70 AMP MANUAL RESET PANEL MOUNT</b>	015527	1
6	<b>BREAKER, 50 AMP MANUAL RESET PANEL MOUNT</b>	021256	1
7	<b>BOOT, CIRCUIT BREAKER</b>	021253	2
8	<b>SCREW, #10-24 X 3/8" PHILLIPS PAN HEAD</b>	F05004-3	3
9	<b>NUT, #10-24 SELF LOCKING</b>	F05010-14	3

## 5.5 Front Panel Assembly & Harnesses

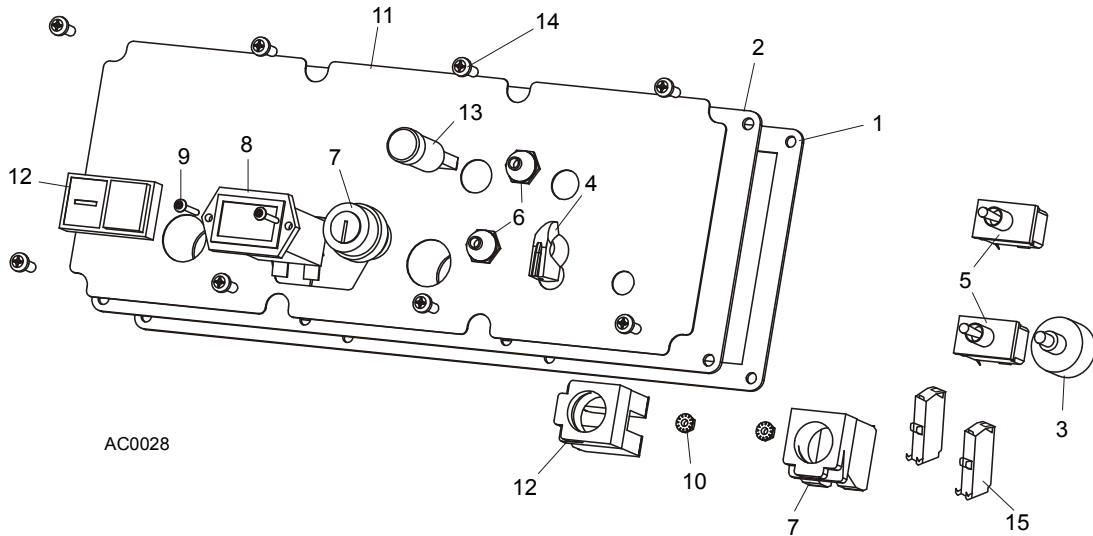

REF	DESCRIPTION (◆ Indicates Parts Available In Assemblies Only)	PART #	QTY.
	<b>PANEL ASSEMBLY, AC SUPER CONTROL FRONT (EA20, EA25)</b>	087387	1
1	Gasket, Front Panel	088387	1
2	Panel Weldment, Control	087316	1
3	Switch Assembly, Feed Rate	E20519	1
4	Knob, Feed Rate With Set Screw	P06257	1
5	Switch, Toggle	024200	2
6	Boot, Toggle Switch Rubber	P02575	2
7	Switch, Key	087350	1
8	Meter, Hour	015401	1
9	Screw, 6-32 x 3/4" Socket Button Head Cap Stainless Steel	F05004-93	2
10	Nut, # 6-32 Keps	F05010-59	2
11	Decal, Control Pane	087351	1
12	Switch, START-STOP	087349	1
13	Lamp, Control	087348	1
	<b>HARNESS ASSEMBLY, UPPER WIRING</b>	093167	1
14	Screw, #10-24 x 1/2" Pan Head	F05015-17	8

### 5.6 Solenoids

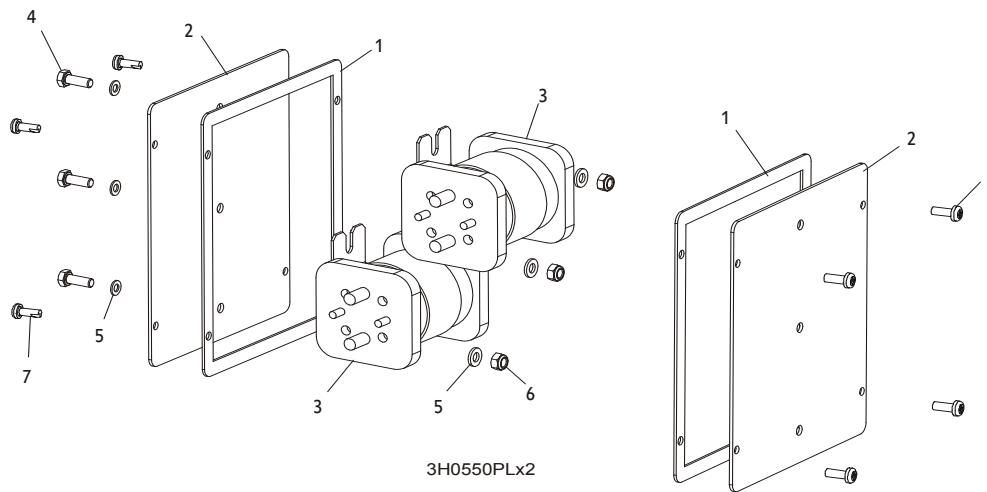

REF	DESCRIPTION (◆ Indicates Parts Available In Assemblies Only)	PART #	QTY.
1	GASKET, SIDE PANEL	015274	2
2	PANEL WELDMENT, SIDE	015307	2
3	SOLENOID, 200A 12V SPST HYDRAULIC PUMP	015470	2
4	BOLT, M6 X 16 8.8 FE/ZN5 PN-M/82105	F81001-15	3
5	WASHER, 6.4 FLAT ZINC	F81053-1	6
6	NUT, M6-8-B HEX NYLON ZINC LOCK	F81031-2	3
	DIODE ASSEMBLY, SOLENOID COIL CHASSIS GND	087496	4
7	BOLT, #10-24 X 1/2 PHILLIPS PAN HEAD TYPE 23	F05015-17	8

## SECTION 6 UP/DOWN SYSTEM

### 6.1 Up/Down Rollers & Covers

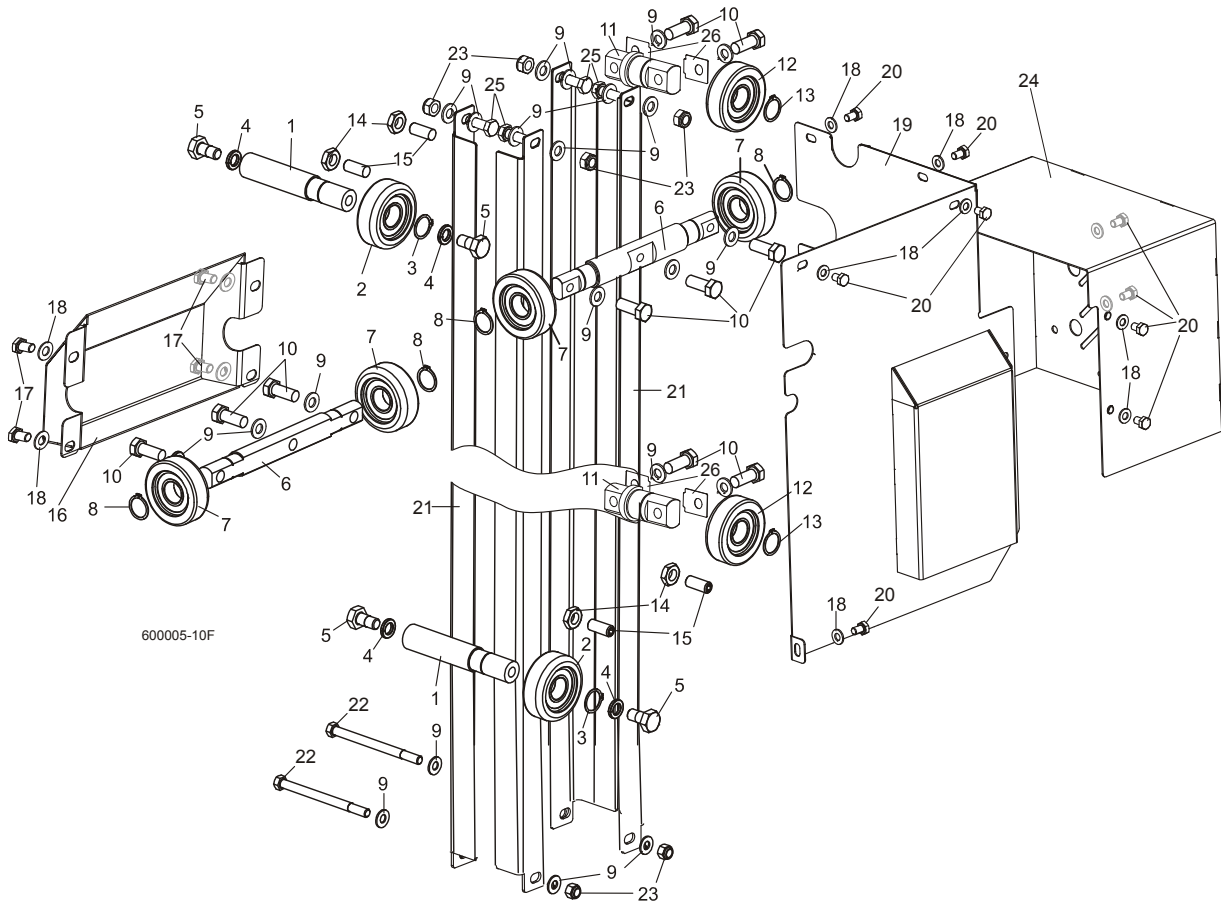

REF	DESCRIPTION (◆ Indicates Parts Available In Assemblies Only)	PART #	QTY.
	<b>ROLLER ASSEMBLY, INSIDE UP/DOWN</b>	089456	2
1	Shaft, Inside Up/Down Roller	088817-1	1
2	Bearing, CBK-468 Rolling	088433	1
3	Ring, Z30 Spring Retaining	F81090-23	1
4	Washer, 13 Zinc Flat	F81056-1	2
5	Bolt, M12x25-8.8 Hex Head Full Thread Zinc	F81004-31	2
	<b>ROLLER ASSEMBLY, OUTSIDE UP/DOWN</b>	089454	2
6	Shaft, Long Up/Down Roller	088815-1	1
7	Bearing, CBK-468 Rolling	088433	2
8	Ring, Z30 Spring Retaining	F81090-23	2
9	<b>Washer, 10.5 Zinc Flat</b>	F81055-1	22
10	<b>Bolt, M10x35-8.8 Hex Head Full Thread Zinc</b>	F81003-17	10
	<b>ROLLER ASSEMBLY, SHORT UP/DOWN</b>	089455	2
11	Shaft, Short Up/Down Roller	088816-1	1
12	Bearing, CBK-468 Rolling	088433	1
13	Ring, Z30 Spring Retaining	F81090-23	1
14	<b>NUT, M10-04-W HEX ZINC THIN</b>	F81033-6	4
15	<b>SCREW, GN 913.3-M10-40-MS SET</b>	F81003-65	4
16	<b>COVER WELDMENT, UP/DOWN ROLLER</b>	507056-1	1

# 6 Up/Down System

## Blade Height Scale

17	BOLT, M8X16-8.8-B HEX HEAD FULL THREAD ZINC	F81002-20	4	
18	WASHER, 8.4 ZINC FLAT	F81054-1	13	
19	GUARD WELDMENT, RA-08 UP/DOWN GEAR BOX SIDE PTD	091319-1	1	
20	BOLT, M8X12-8.8 HEX HEAD FULL THREAD ZINC	F81002-6	9	
21	ANGLE, MAST TUBE STAINLESS	088492	4	
22	BOLT, M10X125-8.8 HEX HEAD ZINC	F81003-18	2	
23	NUT, M10-8-B HEX NYLON ZINC LOCK	F81033-1	6	
24	GUARD, UP/DOWN MOTOR PAINTED	090501-1	1	
25	BOLT, M10X30-5.8 HEX HEAD FULL THREAD	F81003-2	4	
26	SPACER, ROLLER ASSEMBLY, SHORT UP/DOWN	510616	-	

## 6.2 Blade Height Scale

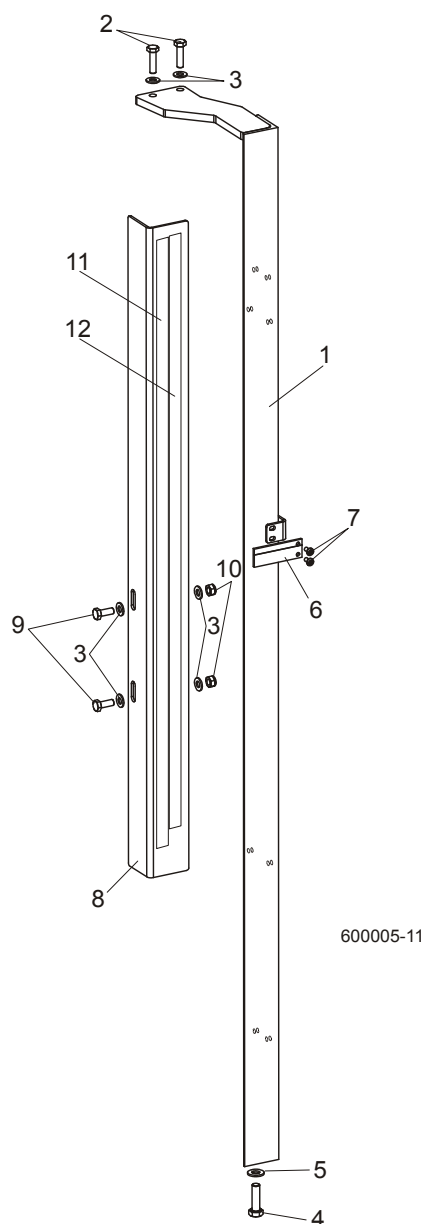

REF	DESCRIPTION (◆ Indicates Parts Available In Assemblies Only)	PART #	QTY.	
1	MOUNT WELDMENT, SCALE PAINTED	088554-1	1	

2	BOLT, M8 x 30-8.8-B HEX HEAD FULL THREAD ZINC	F81002-7	2	
3	WASHER, 8.4 ZINC FLAT	F81054-1	6	
4	BOLT, M10 x 35-8.8 HEX HEAD FULL THREAD ZINC	F81003-17	1	
5	WASHER, 10.5 ZINC FLAT	F81055-1	1	
6	INDICATOR, BLADE HEIGHT SCALE	094821	1	
7	SCREW, #10-24 X 3/8 PHILLIPS PAN HEAD ZINC	F05004-3	2	
8	ANGLE, SCALE MOUNT	088785-1	1	
9	BOLT, M8 X 20-8.8-B HEX HEAD FULL THREAD ZINC	F81002-4	2	
10	NUT, M8-8-B HEX NYLON ZINC LOCK	F81032-2	2	
11	DECAL, METRIC SCALE	S11711	1	
12	DECAL, 16-40 MM METRIC SCALE	P12040-1	1	

### 6.3 Up/Down Chain & Sprockets

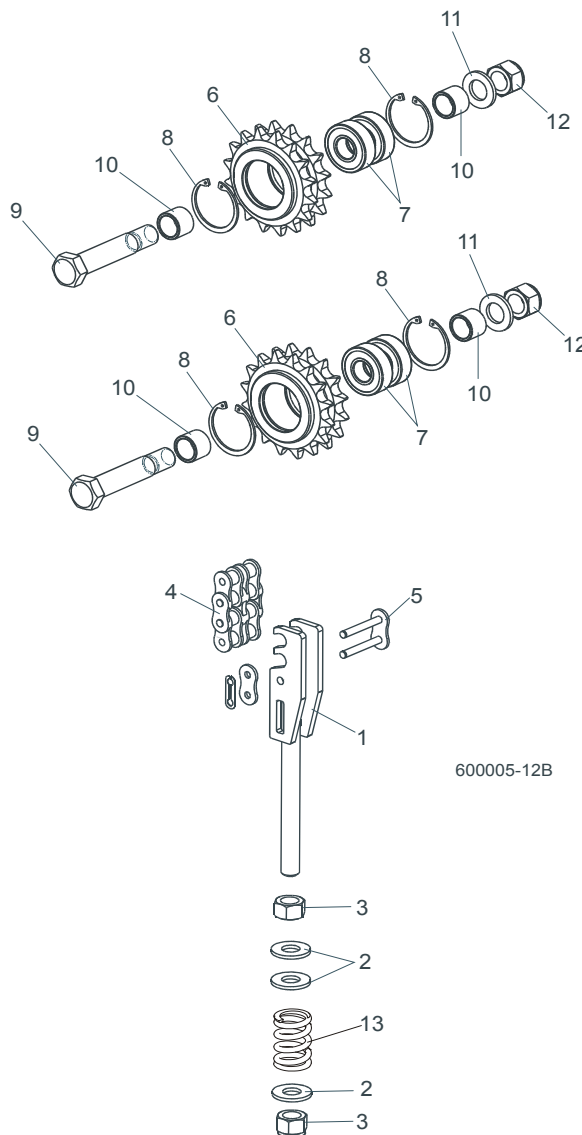

REF	DESCRIPTION (◆ Indicates Parts Available In Assemblies Only)	PART #	QTY.	
1	TENSIONER WELDMENT, UP/DOWN CHAIN ZINC	512181-1	1	
2	WASHER, 13 ZINC FLAT	F81056-1	3	
3	NUT, M12-8 HEX NYLON ZINC LOCK	F81034-2	2	

# 6 Up/Down System

## Up/Down Drive Assembly

4	CHAIN, 12B-2 97-LINK	512197	1	
5	LINK, 12B-2Pz MASTER	099249	1	
	<b>SPROCKET ASSEMBLY, UP/DOWN IDLER</b>	<b>512180</b>	<b>2</b>	
6	Sprocket, Zinc-plated	512179-1	1	
7	Bearing, 6203-2RS FLT Rolling	086114	2	
8	Ring, W40 Spring Retaining	F81090-3	2	
9	Bolt, M16D1F6 x 90-8.8 Hex Fit Short Thread Zinc	F81006-15	1	
10	Spacer, Idler Zinc	088792-1	2	
11	Washer, 17 Zinc Flat	F81058-1	1	
12	Nut, M16-8 Hex Nylon Zinc Lock	F81036-2	1	
13	Spring, 14x30x3,2	090797	1	

### 6.4 Up/Down Drive Assembly

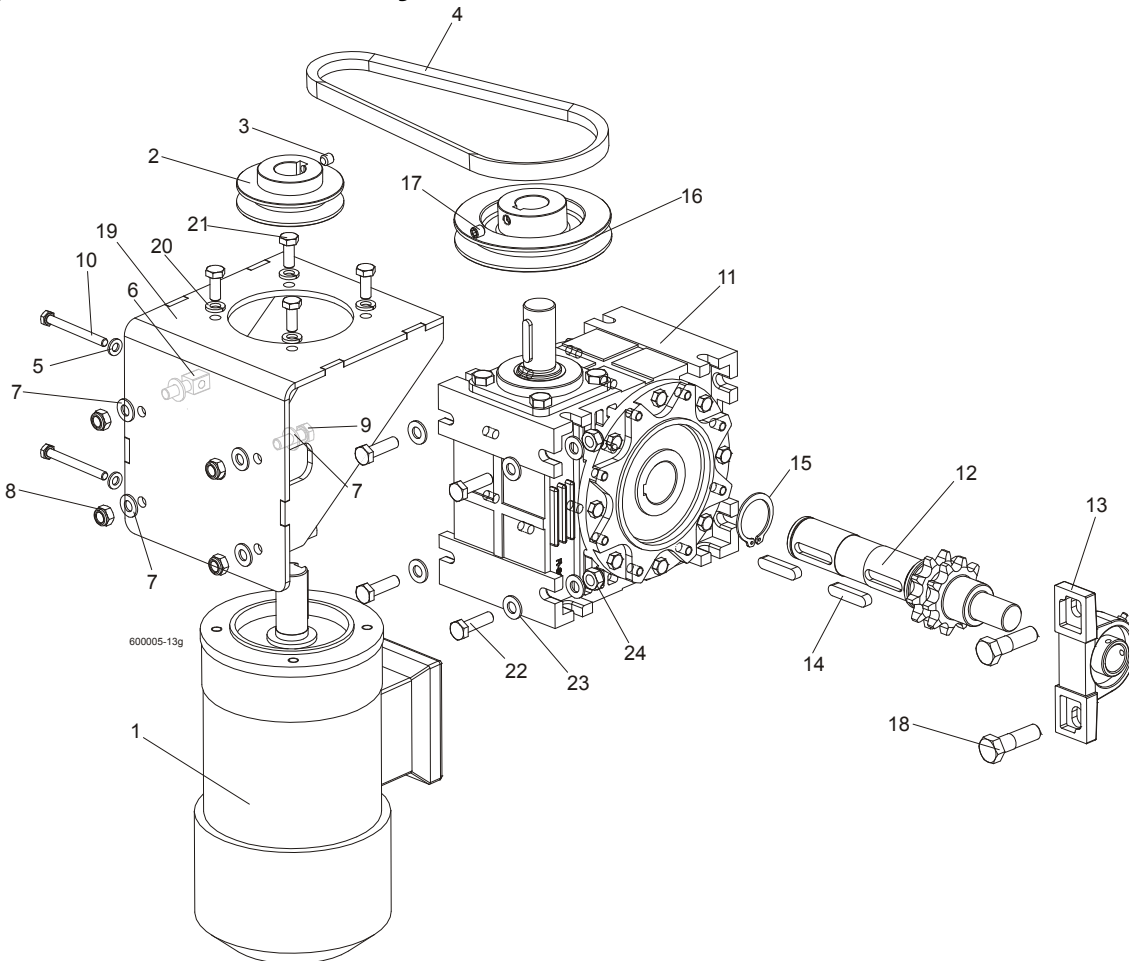

REF	DESCRIPTION (◆ Indicates Parts Available In Assemblies Only)	PART #	QTY.	
	<b>MOTOR W/MOUNT BRACKET, AC UP/DOWN</b>	<b>090493</b>	<b>1</b>	
1	AC Motor, 2 gear STKg90 6/4L2 IMB14/162	086530	1	
2	Pulley, AC Motor Painted	090497-1	1	
3	Screw, M8x8-33H Hex Socket Set Flat Point Zinc	F81014-1	1	
4	V-Belt, HA-670	091328	1	
5	Washer, 6.4 Zinc Flat	F81053-1	2	



6	Bolt, Special - Zinc Plated	088962-1	2	
7	Washer, 8.4 Zinc Flat	F81054-1	8	
8	Nut, M8-8-B Hex Nylon Zinc Lock	F81032-2	4	
9	Bolt, M8X25-8.8-B Hex Head Full Thread Zinc	F81002-5	2	
10	Bolt, M6x60-8.8 Hex Head Full Thread Zinc	F81001-9	2	
	<b>GEAR BOX ASSEMBLY, UP/DOWN DRIVE</b>	<b>091310</b>	<b>1</b>	
11	Gear Box, R80/64/WBS/D1,N+S,V5	097701	1	
12	Output Shaft W/Sprocket, Up/Down Drive	517320-1	1	
13	Bearing Assembly, UCP205 CX	088468	1	
14	KEY, . A10x8x45 PN-91/M-85005 PARALLEL	091312	1	
15	Ring, Outside Retaining Z38	F81090-26	1	
16	<b>PULLEY, UP/DOWN GEAR PAINTED</b>	091308-1	1	
17	<b>SCREW, M8X8-33H HEX SOCKET SET FLAT POINT ZINC</b>	F81014-1	1	
18	<b>BOLT, M12 X 40-8.8 HEX HEAD ZINC</b>	F81004-1	1	
19	<b>BRACKET, AC UP/DOWN MOTOR MOUNT PTD</b>	090494-1	1	
20	<b>WASHER 8.2 SPLIT LOCK ZINC</b>	F81054-4	4	
21	<b>BOLT, M8 X 20-8.8-B HEX HEAD FULL THREAD ZINC</b>	F81002-4	4	
22	<b>BOLT M10x35-8.8 HEX HEAD FULL THREAD ZINC</b>	F81003-17	4	
23	<b>WASHER 10,5Fe/Zn5, SPECIAL</b>	F81055-4	8	
24	<b>NUT,M10-8-B NYLON HEX ZINC LOCK</b>	F81033-1	4	

## 6.5 Safety Switches

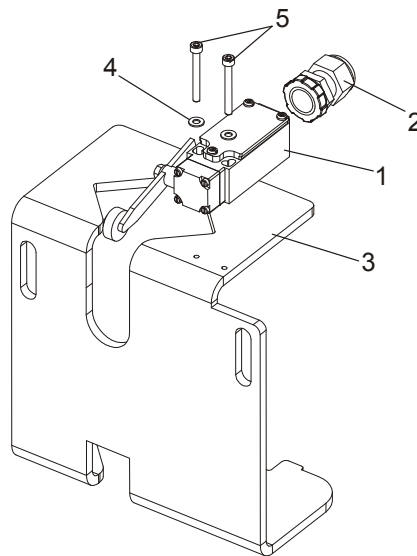

600045B

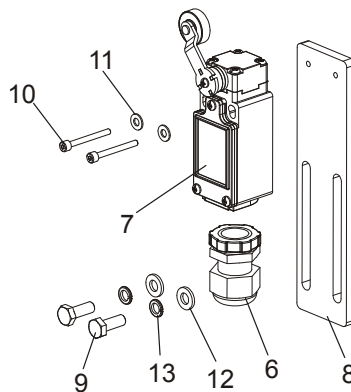

REF	DESCRIPTION (◆ Indicates Parts Available In Assemblies Only)	PART #	QTY.
1	SWITCH , GLCB01A2B SAFETY	086469	2
2	STUFFING-BOX, SKINTOP PG 13,5	086524	2
3	SUPPORT, POWER CORD BRACKET	090460-1 <sup>1</sup>	1
4	WASHER 4,3 FE/ZN5 PN-M/82005	F81051-2	4
5	SCREW, M4x35-8.8 HEX SOCKET HEAD CAP ZINC	F81011-34	4
	<b>KIT, LT70 SAFETY SWITCH LOWER</b>	505711	1
6	STUFFING-BOX, SKINTOP PG 13,5	086524	1
7	LIMIT SWITCH, GLCB01A1B	100931	1
8	BAR, SAFETY SWITCH MOUNT	505125-1	1
9	BOLT, M6 x 16 8.8 Fe/Zn5 PN-M/82105	F81001-15	2
10	BOLT, M3X30 8.8 SOCKET HEAD ZINC	F81011-38	2
11	WASHER 4,3 FE/ZN5 PN-M/82005	F81051-2	2
12	WASHER, M6, FLAT,ZINC	F81053-1	2
13	WASHER, M6 SPLIT LOCK ZINC	F81053-3	2

<sup>1</sup> LT70DC version only.

## SECTION 7 FEED SYSTEM & TRACK ROLLERS

### 7.1 Upper Track Rollers And Wipers

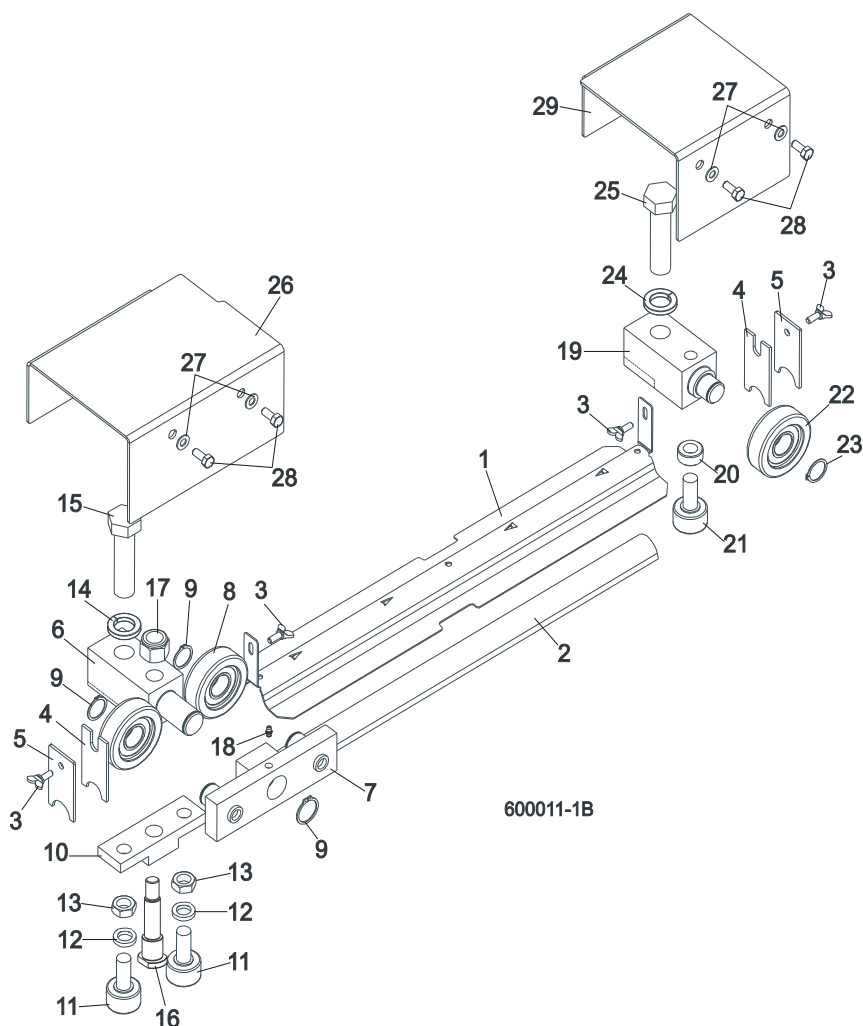

REF	DESCRIPTION (◆ Indicates Parts Available In Assemblies Only)	PART #	QTY.
1	<b>COVER, LT40/70 MIDDLE TRACK - SERVICE</b>	092868-S	1
	Cover, LT40/70 Middle Track Ptd	092868-1	1
2	Strip, 3/16 X 2 X 23 Felt	S09915	1
3	<b>SCREW, M6X20 DIN 316 WING</b>	F81001-58	4
4	<b>WIPER, TOP RAIL</b>	M04113	2
5	<b>PLATE, TRACK WIPER</b>	088559-1	2
	<b>ROLLER ASSEMBLY, UPPER TANDEM TRACK</b>	088530	1
6	Block, Tandem Roller Mount	088532	1
7	Block Assembly, Tandem Roller	088535	1
8	Bearing, CBK-468 Rolling	088433	2
9	Ring, Z30 Spring Retaining	F81090-23	2
10	Block, Cam Follower Mount	088520	1
11	Bearing, Cam Follower (McGill)	012797	2
12	Washer, 16.3 Split Zinc Lock	F81058-2	2
13	Nut, 5/8"-18 Zinc	F05010-11	2

14	Washer, Z24.5 Split Zinc Lock	F81061-4	1	
15	Bolt, M24 x 2 x 90-8.8 Hex Head Full Thread Zinc	F81009-2	1	
16	Pin, Cam Follower Mount	088531	1	
17	Nut, M16-8 Hex Nylon Zinc Lock	F81036-2	1	
18	Fitting, M6 Straight Grease	086280	1	
	<b>ROLLER ASSEMBLY, REAR UPPER TRACK</b>	088529	1	
19	Block, Rear Upper Roller Mount	088528	1	
20	Spacer, Cam Follower	088536	1	
21	Bearing, Cam Follower (McGill)	012797	1	
22	Roller, CBK-468	088433	1	
23	Ring, Z30 Spring Retaining	F81090-23	1	
24	Washer, Z24.5 Split Zinc Lock	F81061-4	1	
25	Bolt, M24x2x90-8.8 Hex Head Full Thread Zinc	F81009-2	1	
26	<b>COVER, TANDEM ROLLER</b>	088526-1	1	
27	<b>WASHER, 6.4 ZINC FLAT</b>	F81053-1	4	
28	<b>BOLT, M6X16 8.8 HEX HEAD FULL THREAD ZINC</b>	F81001-15	4	
29	<b>COVER, REAR UPPER ROLLER</b>	088527-1	1	

## 7.2 Power Feed Assembly

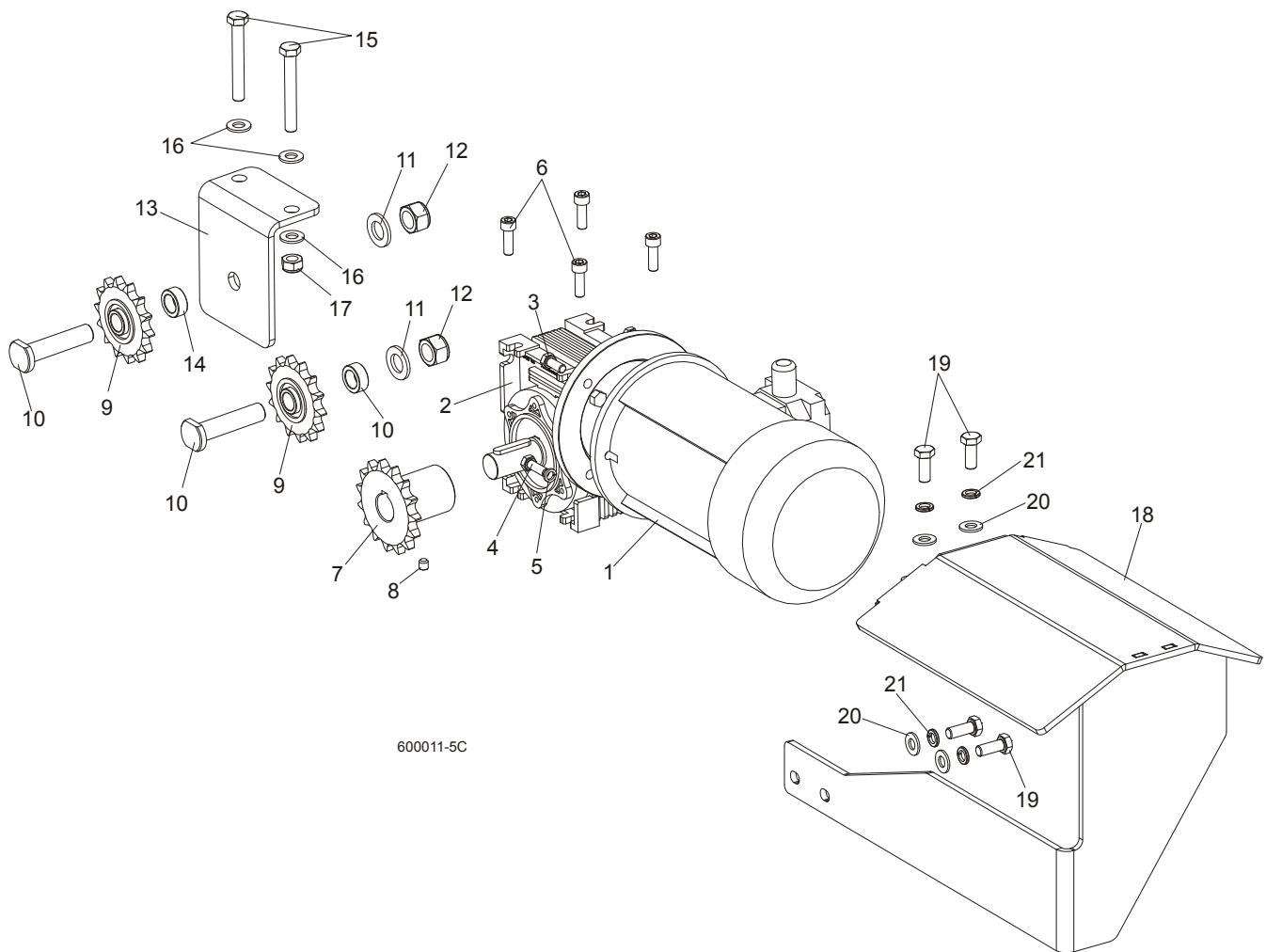

REF	DESCRIPTION (◆ Indicates Parts Available In Assemblies Only)	PART #	QTY.
	<b>MOTOREDUCER MR-50/7.5/1.1-1380/K3/B8</b>	100936	1
1	Electric motor 1,1kW AC	090104	1
2	MOTOREDUCER, MR-50/7.5/DO SILN/K3,N+S,B8	100935	1
3	BOLT, M8X20MM, HEX HEAD,GR 5.8 ZINC	F81002-4	2
4	BOLT,M8X25-8.8-B HEX HEAD FULL THREAD	F81002-5	2
5	WASHER 8,2 FE/ZN9	F81054-4	2
6	SCREW, M8x25 -8.8 HEX SOCKET HEAD CAP	F81002-21	4
7	SPROCKET, 10B Z15 ZINC	088541-1	1
8	SCREW, M8x8-33H HEX SOCKET SET FLAT POINT ZINC	F81014-1	2
9	SPROCKET, KSR 16.L0.10.10.14.08 W/BEARING	088867	2
10	PIN, ZINC SPROCKET MOUNT	088994-1	2
11	WASHER, 17 ZINC FLAT	F81058-1	2
12	NUT, M16-8 HEX NYLON ZINC LOCK	F81036-2	2
13	BRACKET, POWER FEED SPROCKET MOUNT	088507-1	1
14	SPACER, POWER FEED SPROCKET	088550-1	1

<b>15</b>	<b>BOLT, M10x75-8.8 HEX HEAD ZINC</b>	F81003-15	2	
<b>16</b>	<b>WASHER, 10.5 ZINC FLAT</b>	F81055-1	4	
<b>17</b>	<b>NUT, M10-8-B HEX NYLON ZINC LOCK</b>	F81033-1	2	
	<b>GUARD, LT70AC POWER FEED MOTOR COMPLETE</b>	504651	1	
<b>18</b>	GUARD, LT70AC POWER FEED MOTOR	504652-1	1	
<b>19</b>	BOLT, M10-1.5X25MM HH GR8.8	F81003-11	4	
<b>20</b>	WASHER, 10.5 ZINC FLAT	F81055-1	4	
<b>21</b>	WASHER,10.2 SPLIT LOCK ZINC	F81055-2	4	

**7.3 Feed Chain/Stop**

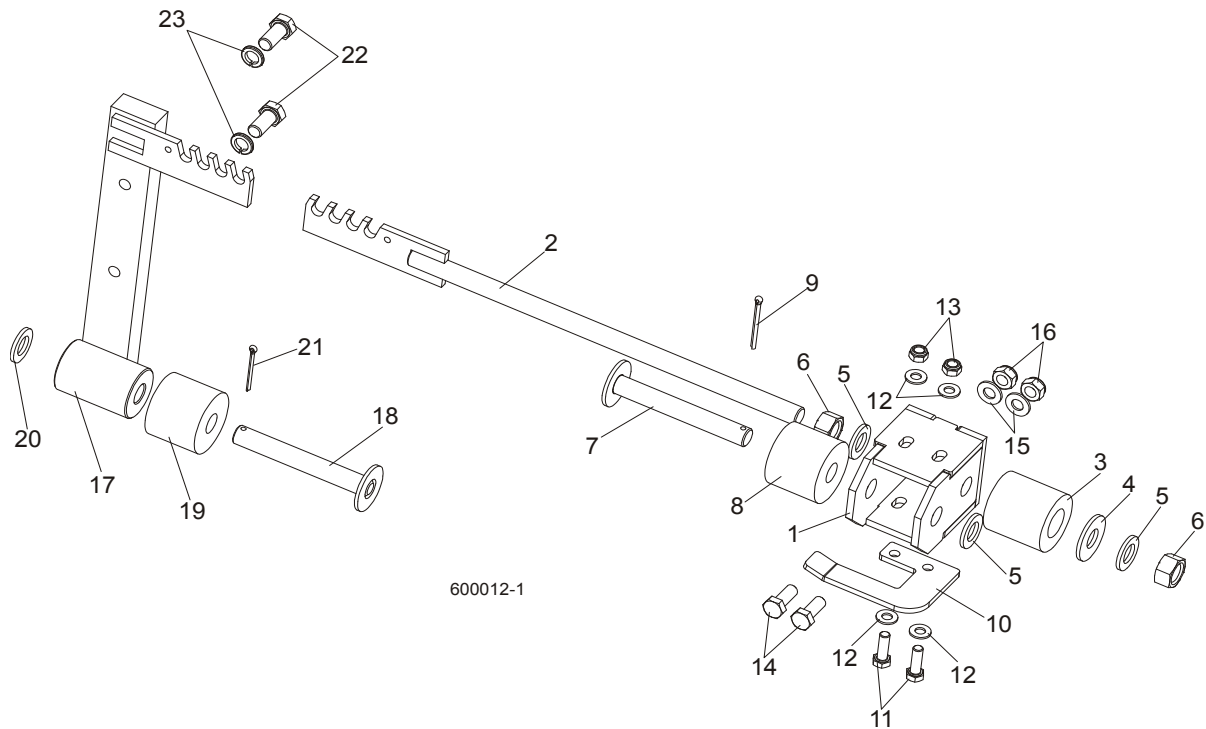

600012-1

REF	DESCRIPTION (◆ Indicates Parts Available In Assemblies Only)	PART #	QTY.
1	MOUNT WELDMENT, FRONT CARRIAGE STOP	089365-1	1
2	TENSIONER WELDMENT, POWER FEED CHAIN	089364-1	1
3	SPRING, LT15 BLADE TENSIONER	014828	1
4	WASHER, ZINC SPECIAL	089360-1	1
5	WASHER, 17 ZINC FLAT	F81058-1	3
6	NUT, M16-5.8 ZINC HEX	F81036-1	2
7	PIN, RUBBER CARRIAGE STOP	089361-1	1
8	BUSHING, RUBBER STOP	P12165	1
9	PIN, S-Zn 4x25 COTTER	F81043-2	1
10	BRACKET, LIMIT SWITCH	086473-1	1
11	BOLT, M8X25-8.8-B HEX HEAD FULL THREAD ZINC	F81002-5	2
12	WASHER, 8.4 ZINC FLAT	F81054-1	4
13	NUT, M8-8-B HEX NYLON ZINC LOCK	F81032-2	2
14	BOLT, M10X25 8.8 HEX HEAD FULL THREAD	F81003-31	2
15	WASHER, 10.5 ZINC FLAT	F81055-1	2
16	NUT, M10-8-B HEX NYLON ZINC LOCK	F81033-1	2
	STOP ASSEMBLY, REAR POWER FEED	089362	1
17	Stop Weldment, Rear Power Feed	088346-1	1
18	Pin, Rubber Carriage Stop	089361-1	1
19	Bushing, Rubber Stop	P12165	1
20	Washer, 17 Zinc Flat	F81058-1	1
21	Pin, S-Zn 4x25 Cotter	F81043-2	1
22	BOLT, M12X25-8.8 HEX HEAD FULL THREAD ZINC	F81004-31	2
23	WASHER, 13 ZINC FLAT	F81056-1	2



<b>CHAIN, 10B-1 POWER FEED</b>	088670	1	
<b>LINK, 10B-1PZ MASTER</b>	088671	2	

### 7.4 Lower Track Rollers

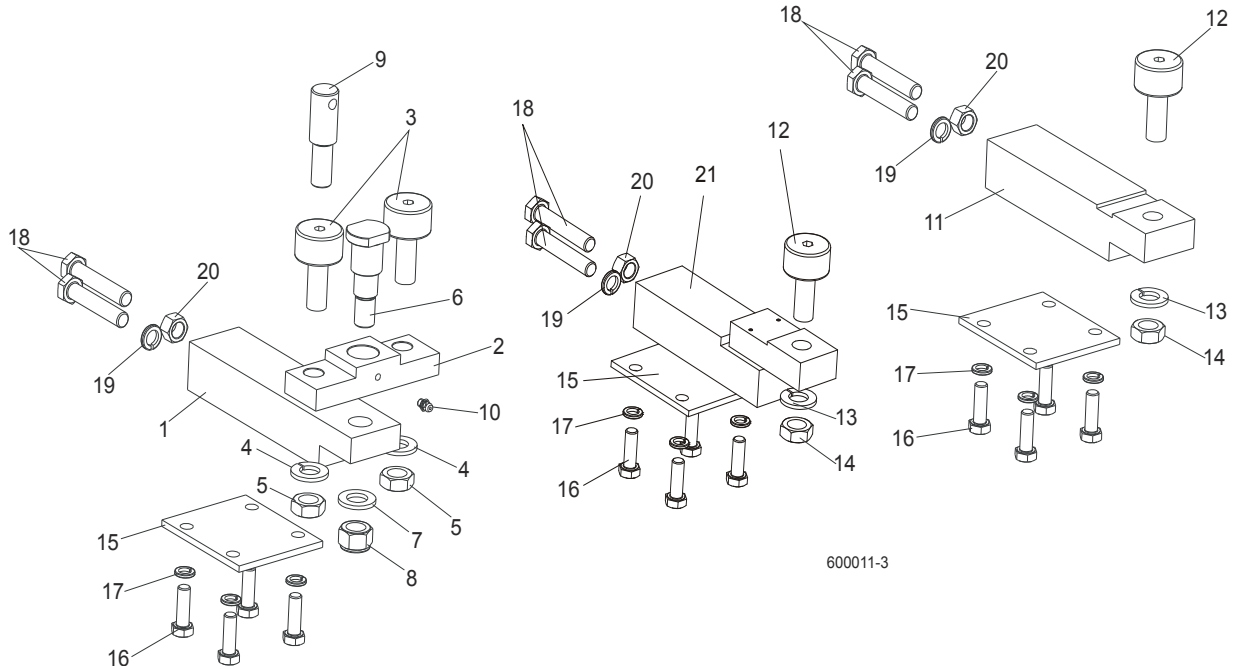

REF	DESCRIPTION (◆ Indicates Parts Available In Assemblies Only)	PART #	QTY.
	<b>BLOCK ASSEMBLY, VERTICAL MAST ALIGNMENT DOUBLE</b>	088523	1
1	Block, Vertical Mast Alignment Double	088517	1
2	Block, Cam Follower Mount	088520	1
3	Bearing, Cam Follower (McGill)	012797	2
4	Washer, 16.3 Split Zinc Lock	F81058-2	2
5	Nut, 5/8"-18 Zinc	F05010-11	2
6	Pin, Cam Follower Mount	088521	1
7	Washer, 17 Zinc Flat	F81058-1	1
8	Nut, M16-8 Hex Nylon Zinc Lock	F81036-2	1
9	Pin, Safety Lock	088519	1
10	Fitting, M6 Straight Grease	086280	1
	<b>BLOCK ASSEMBLY, VERTICAL MAST ALIGNMENT SINGLE</b>	088524	1
11	Block, Vertical Mast Alignment Single	088518	1
12	Bearing, Cam Follower (McGill)	012797	1
13	Washer, 16.3 Split Zinc Lock	F81058-2	1
14	Nut, 5/8"-18 Zinc	F05010-11	1
15	<b>PLATE, LOWER TRACK ROLLER RETAINER</b>	088516	3
16	<b>BOLT, M10X30-5.8 HEX HEAD FULL THREAD ZINC</b>	F81003-2	12
17	<b>WASHER, 10.2 SPLIT ZINC LOCK</b>	F81055-2	12
18	<b>BOLT, M12X1.25X65-8.8 HEX HEAD FULL THREAD ZINC</b>	F81004-40	6
19	<b>WASHER, Z12.2 SPLIT ZINC LOCK</b>	F81056-2	3
20	<b>NUT, M12X1.25-8 ZINC HEX</b>	F81034-8	3
21	<b>BLOCK WELDMENT, LOWER TRACK ROLLER MOUNT</b>	091425	1

**SECTION 8 BED FRAME ASSEMBLY**

**8.1 Bed Rail Assembly (L type frame)**

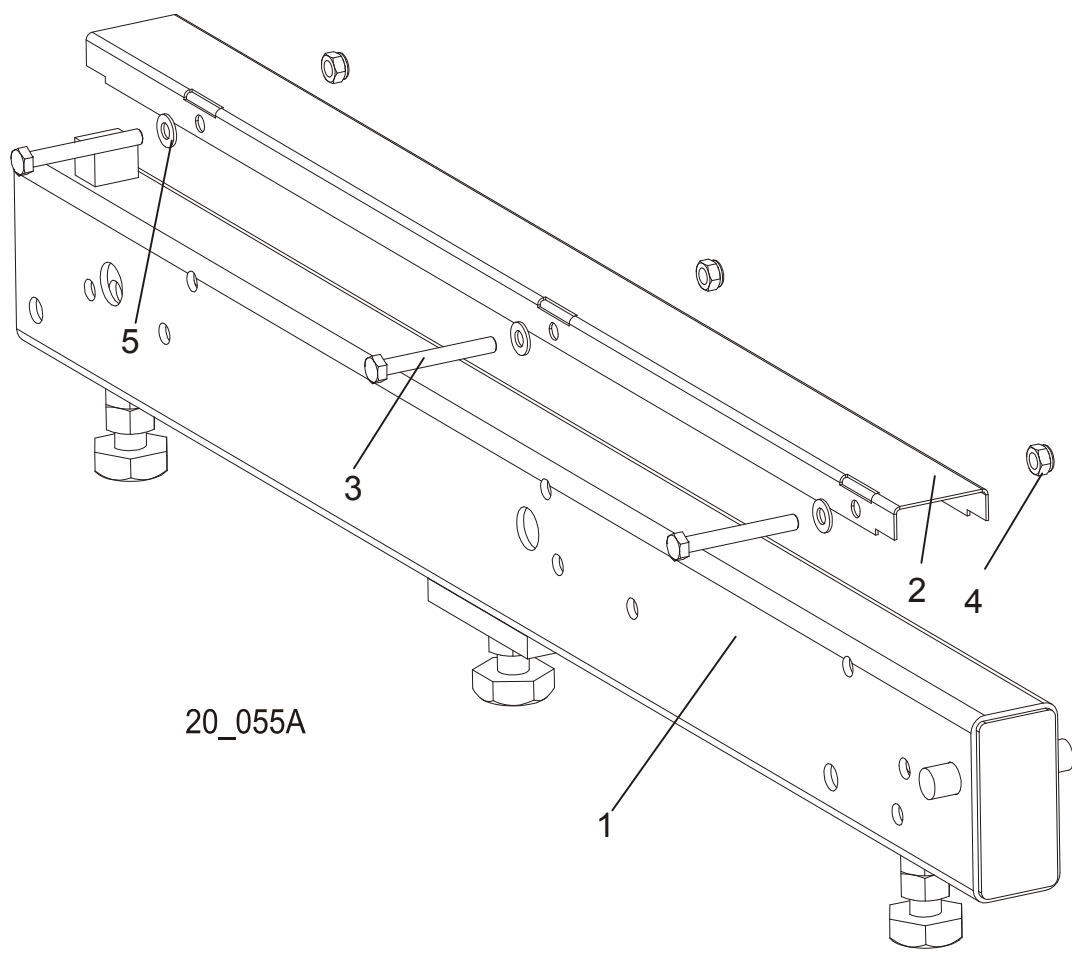

REF	DESCRIPTION (◆ Indicates Parts Available In Assemblies Only)	PART #	QTY.	
1	LONG BED RAIL ASSEMBLY	089385	6	
2	COVER, STAINLESS STEEL BED RAIL	099124	1	
3	BOLT, M8X65-5,8 ZINC HEX HEAD	F81002-3	3	
4	NUT, M8-8-B-ZINC HEX NYLON LOCK	F81032-2	3	
5	WASHER, 8.4 FLAT ZINC	F81054-1	3	

8.2 Bed Rail Assembly (L type frame)

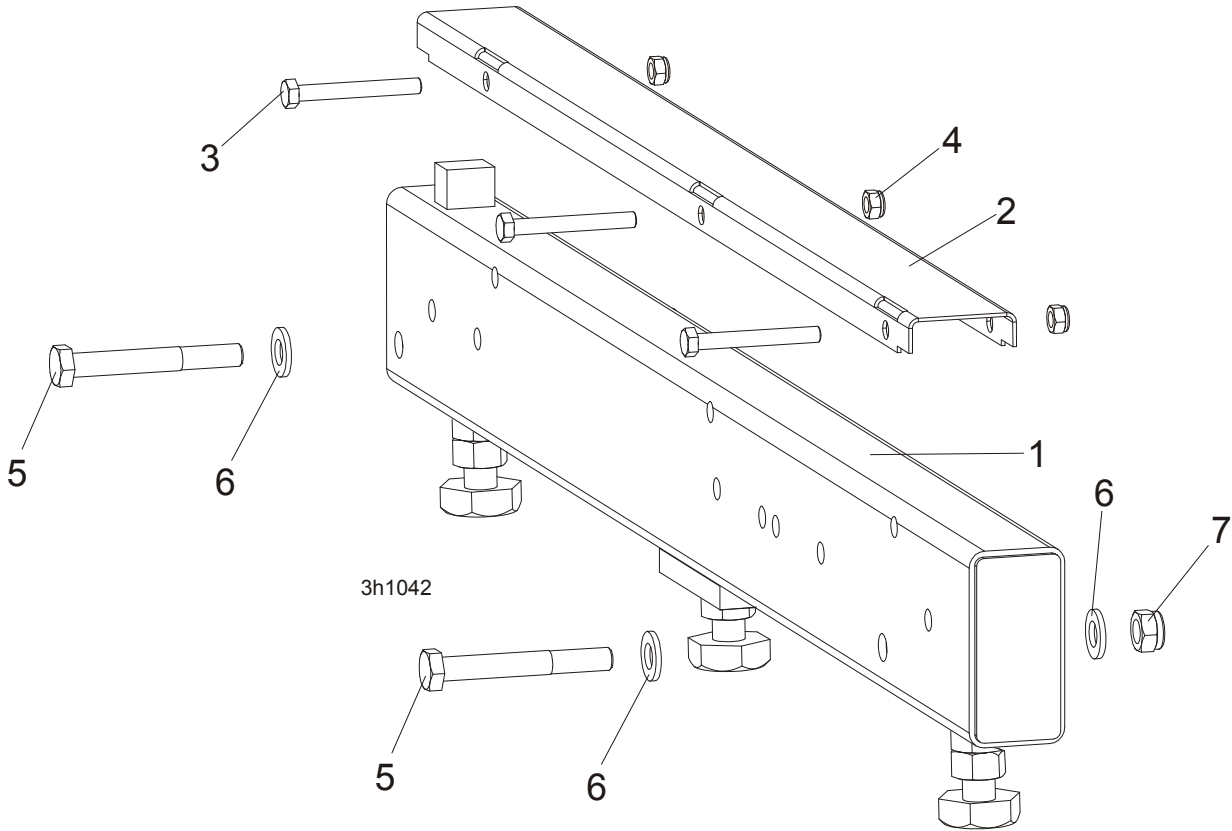

REF	DESCRIPTION (◆ Indicates Parts Available In Assemblies Only)	PART #	QTY.
1	BED RAIL ASSEMBLY	096993	1
2	COVER, STAINLESS STEEL BED RAIL	099124	1
3	BOLT, M8X65-5,8 ZINC HEX HEAD	F81002-3	3
4	NUT, M8-8-B-ZINC HEX NYLON LOCK	F81032-2	3
5	BOLT,M12X90-8.8 HEX HEAD ZINC	F81004-2	2
6	WASHER, M12 , FLAT, ZINC	F81056-1	4
7	NUT,M12-8 ,HEX,NYLON,ZINC,LOCK	F81034-2	2

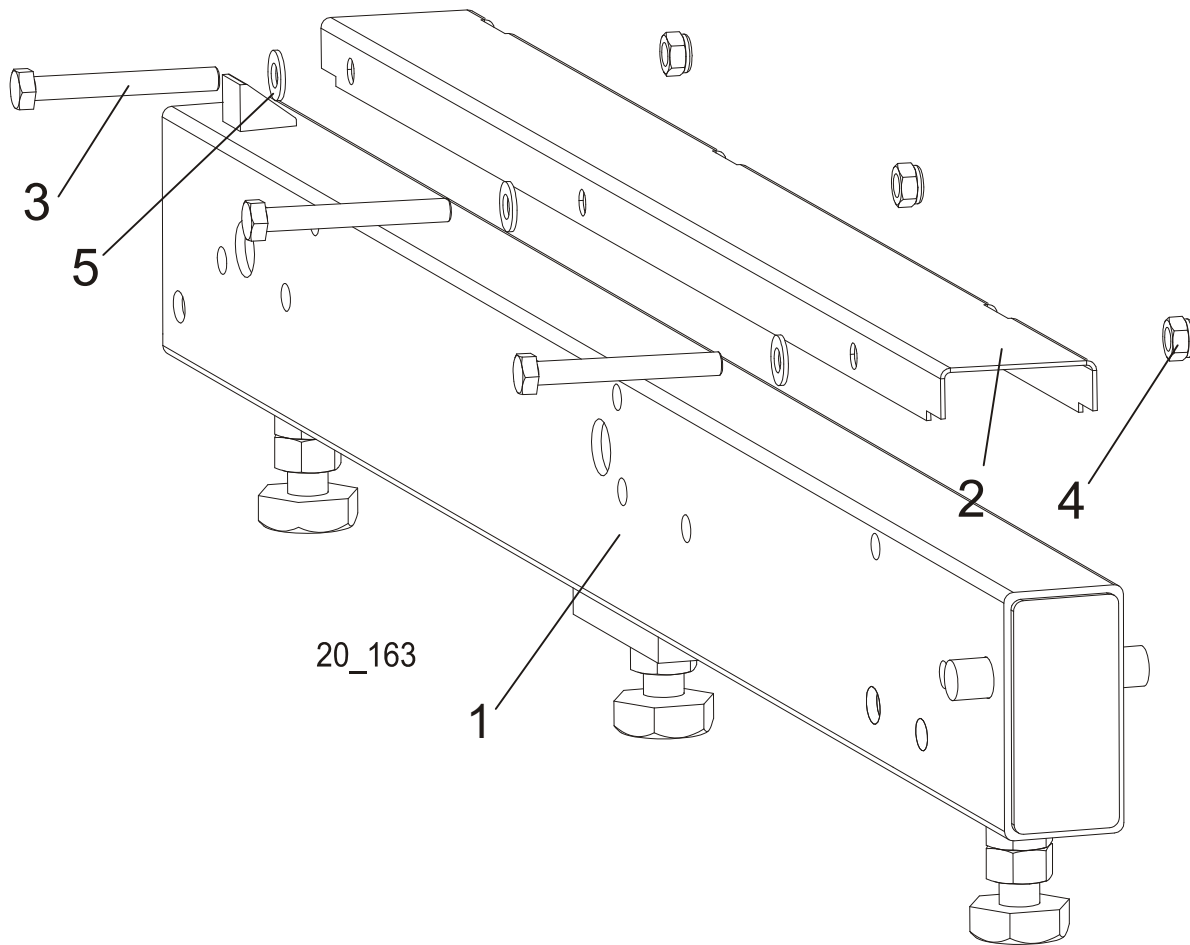
**8.3 Bed Rail Assembly (L type frame)**

REF	DESCRIPTION (◆ Indicates Parts Available In Assemblies Only)	PART #	QTY.	
1	BED TRANSVERSE	100680	1	
2	COVER, STAINLESS STEEL BED RAIL	099124	1	
3	BOLT, M8X65-5,8 ZINC HEX HEAD	F81002-3	3	
4	NUT, M8-8-B-ZINC HEX NYLON LOCK	F81032-2	3	
5	WASHER, 8.4 FLAT ZINC	F81054-1	3	

8.4 Leg, Stationary

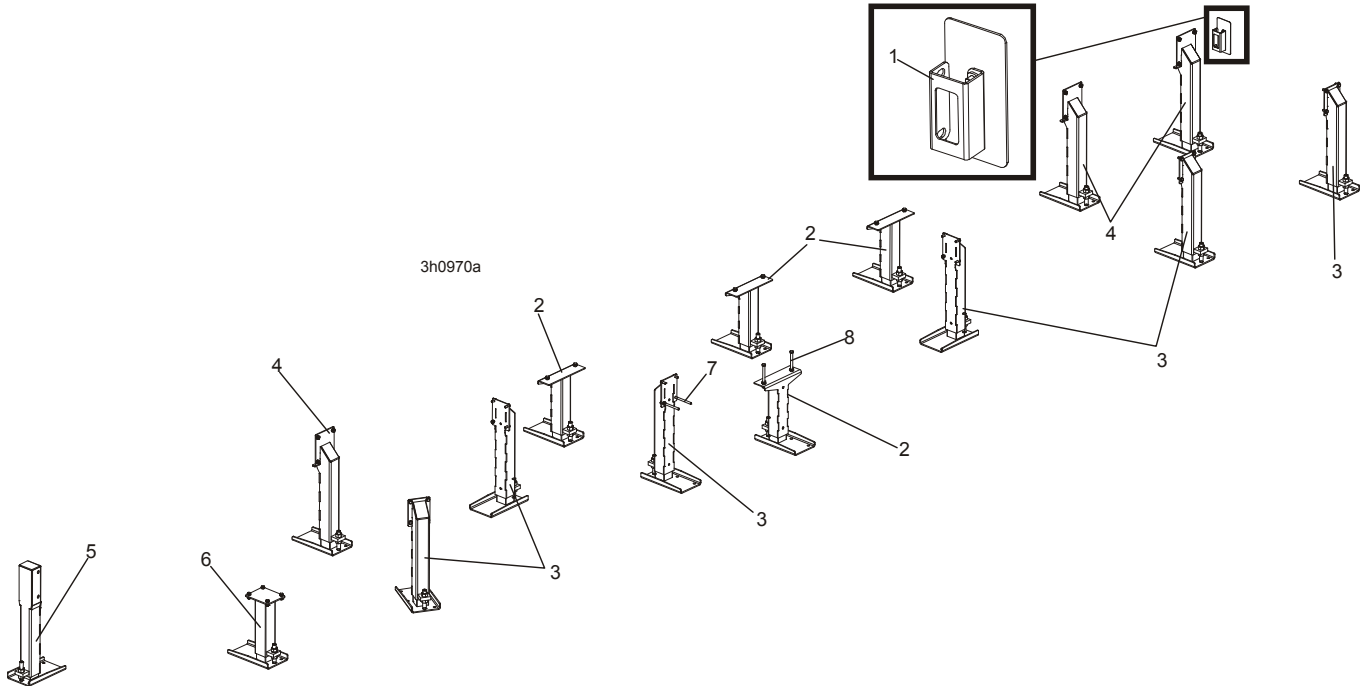

REF	DESCRIPTION (◆ Indicates Parts Available In Assemblies Only)	PART #	QTY.
	<b>LEG KIT, "LT70L Super" FRAME OUTRIGGER STATIONARY</b>	<b>505408</b>	<b>1</b>
1	LEG, OUTRIGGER STATIONARY LEFT	501639	6
2	LEG, OUTRIGGER STATIONARY MIDDLE	501637	4
3	LEG, OUTRIGGER STATIONARY RIGHT	501640	3
4	LEG, OUTRIGGER STATIONARY FRONT	501641	1
5	LEG, OUTRIGGER STATIONARY	505766	1
6	BOLT, M10x125-8.8 HEX HEAD ZINC	F81003-18	2
7	BOLT, M12x130-8.8-Fe/Zn5 PN-M/82101	F81004-36	2

**8.5 Roller Assembly LT70 Remote**

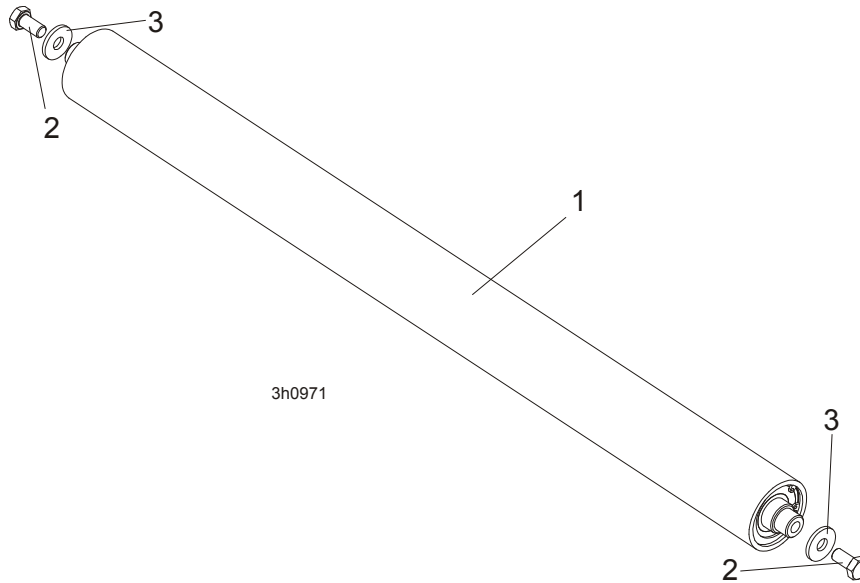

REF	DESCRIPTION (◆ Indicates Parts Available In Assemblies Only)	PART #	QTY.	
	<b>ROLLER ASSEMBLY, LT70 REMOTE PAINTED</b>	<b>093291-1</b>	<b>1</b>	
1	ROLLER, BOTTOM LT70AH	091782-1	1	
2	BOLT, M10x20MM,HEX HEAD,GR 5.8 ZINC	F81003-1	2	
3	WASHER,10.5 ZINC FLAT SPECIAL	F81055-6	2	

### 8.6 Pivot Bed Rail Assembly

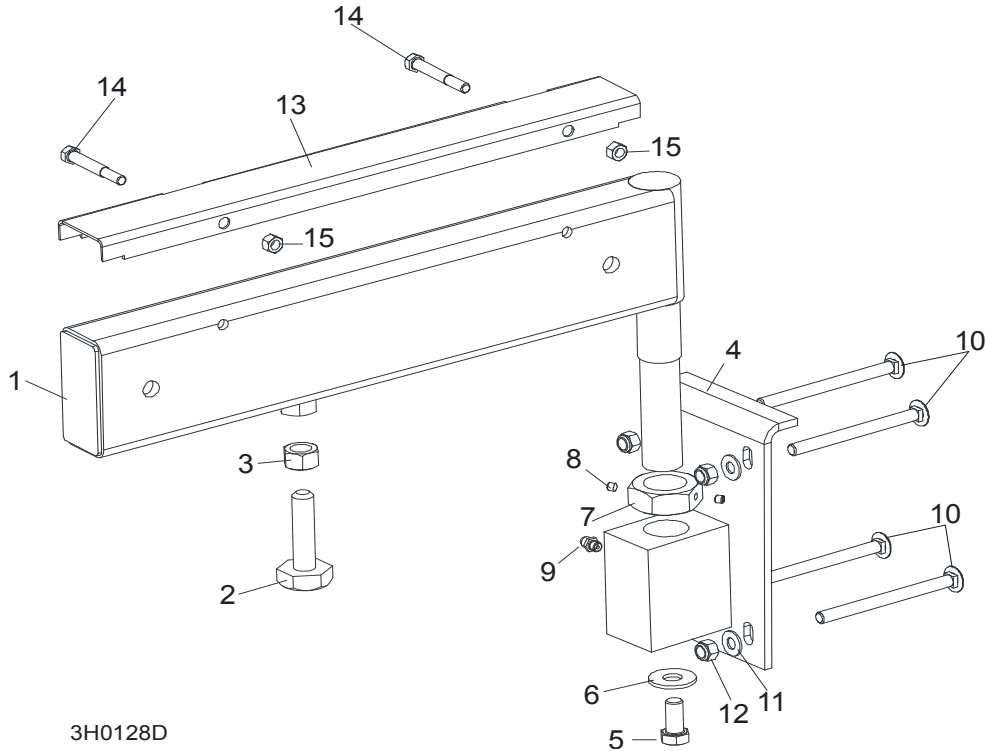

REF	DESCRIPTION (◆ Indicates Parts Available In Assemblies Only)	PART#	QTY.
	<b>PIVOT BED RAIL, COMPLETE</b>	<b>087855</b>	<b>1</b>
1	Pivot Bed Rail Assembly	087848-1	1
	Bolt Assembly, Bed Rail Adjustment		1
2	Bolt, Pivot Bed Rail Adjustment	505006	1
3	Nut, M16-5.8 Zinc Hex	F81036-1	1
4	Bracket, Pivot Bed Rail Mounting	087841-1	1
5	Bolt, M12x25-8.8 Hex Head Full Thread Zinc	F81004-31	1
6	Washer, 9/16" Zinc Flat	F05011-52	1
7	Nut, M32x2-04-B Zinc	087975	1
8	Screw, M6x8 Hex Socket Set Cone Point Zinc	F81013-1	2
9	Fitting, 3/16" Straight Grease	086280	1
10	<b>BOLT, M10X125 8.8 MUSHROOM HEAD SQUARE NECK ZINC</b>	F81003-34	4
11	<b>WASHER, 10.5 FLAT</b>	F81055-1	8
12	<b>NUT, M16-8 HEX NYLON ZINC LOCK</b>	F81036-2	8
	<b>COVER KIT, STAINLESS STEEL PIVOT BED RAIL</b>	N/A	2
13	Cover, Pivot Bed Rail	099123	1
14	Bolt, M8x65-5.8 Hex Head Zinc	F81002-3	2
15	Nut, M8-8-B Hex Nylon Zinc Lock	F81032-2	2
	<b>WRENCH, BED RAIL ADJUSTMENT (<a href="#">Patrz rozdział 8.3</a>)</b>	015970	1

**8.7 Board Return Table**

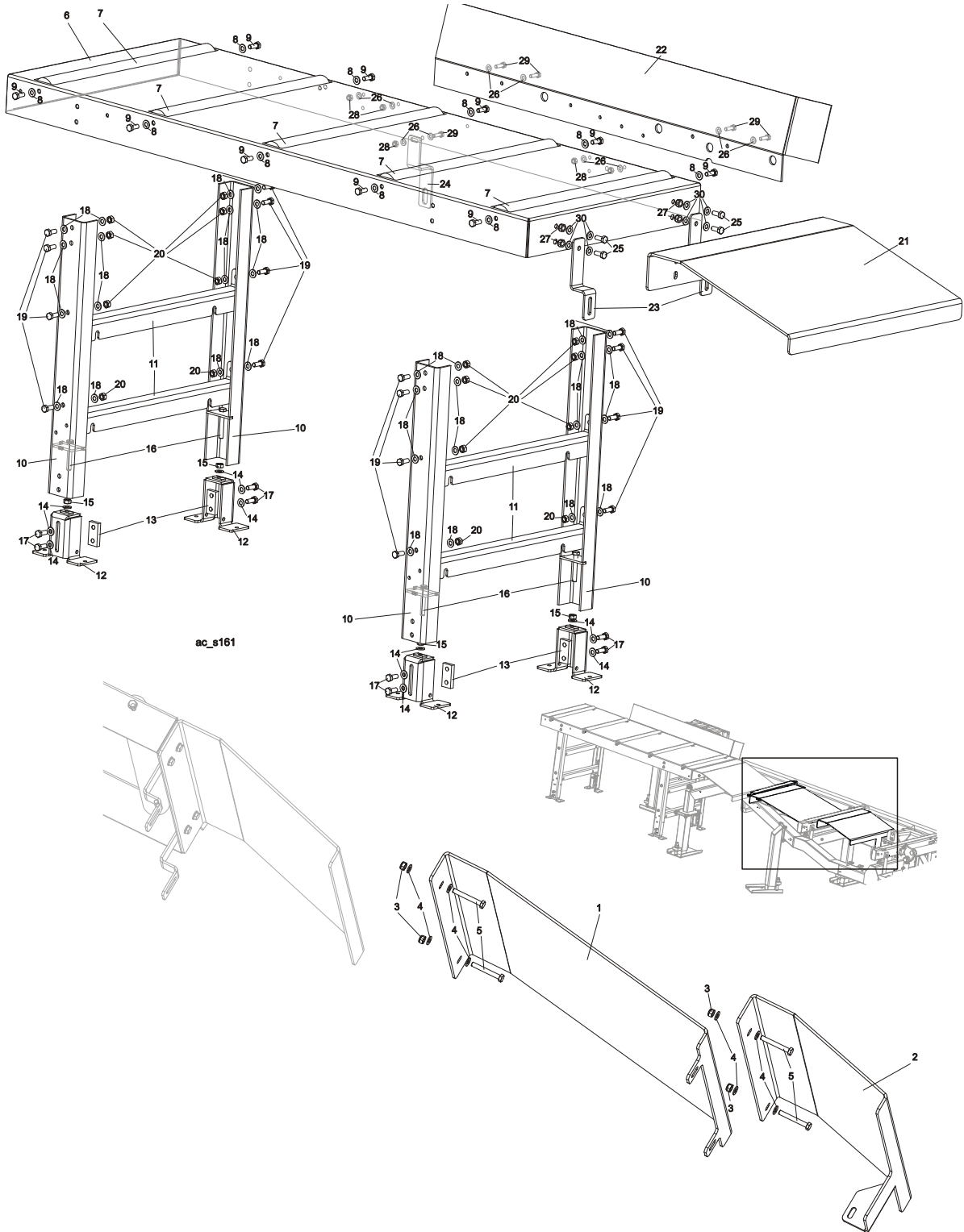

ac\_s161

L.P.	DESCRIPTION (◆ Indicates Parts Available In Assemblies Only)	PART #	QTY.
1	PLATE, BOARD RETURN TABLE FRONT	505781-1	1
2	PLATE, BOARD RETURN TABLE SHORT	505782-1	1
3	NUT, M10-8-B HEX NYLON ZINC LOCK	F81033-1	4



4	WASHER, 10.5 FLAT ZINC	F81055-1	8	
5	BOLT, M10x75-8.8 HEX HEAD ZINC	F81003-15	4	
	LT70L-ST, BOARD RETURN TABLE	505770	1	
	TABLE, L-ST FRAME LONG	505771	1	
	TABLE, M-TYPE FRAME LONG	502539	1	
6	NMF***TOP, EDGER TABLE PTD	500078-1	1	
7	ROLLER, 63.5/20x600 PTD (EDGER)	500077-1	5	
8	WASHER, 10.5 FLAT ZINC	F81055-1	10	
9	BOLT, M10x25-8.8 HEX HEAD FULL THREAD ZINC	F81003-11	10	
	LEG, BOARD RETURN TABLE COMPLETE	501974	2	
10	CHANNEL WLDMT, TABLE LEG PTD	501976	2	
11	CROSS-BAR, TABLE LEG (EDGER)	500074-1	2	
	FOOT, COMPLETE ADJUSTABLE (EDGER)	101014	2	
12	FOOT, ADJUSTABLE PTD (EDGER)	101022-1	1	
13	PLATE, M10 CLAMPING ZINC-PL.	101242-1	1	
14	WASHER, 10.5 FLAT ZINC	F81055-1	3	
15	NUT, M10-8-B HEX ZINC	F81033-3	1	
16	BOLT, M10x70-8.8 HEX HEAD FULL THREAD ZINC	F81003-20	1	
17	BOLT, M10x25-8.8 HEX HEAD FULL THREAD ZINC	F81003-11	2	
18	WASHER, 10.5 FLAT ZINC	F81055-1	16	
19	BOLT, M10x25-8.8 HEX HEAD FULL THREAD ZINC	F81003-11	8	
20	NUT, M10-8-B HEX ZINC	F81033-3	8	
21	PLATE, BOARD RETURN TABLE FRONT	502814-1	1	
22	PLATE, BOARD RETURN TABLE SIDE	501978-1	1	
23	BRACKET, L-TYPE FRAME TABLE - SPECIAL	505769-1	2	
24	BRACKET, L-TYPE FRAME LONG TABLE	505786-1	1	
25	BOLT, M10x25-8.8 HEX HEAD FULL THREAD ZINC	F81003-11	4	
26	WASHER, 8.4 FLAT ZINC	F81054-1	10	
27	NUT, M10-8-B HEX NYLON ZINC LOCK	F81033-1	4	
28	NUT, M8-8-B HEX NYLON ZINC LOCK	F81032-2	5	
29	BOLT, M8x25-8.8-B HEX HEAD FULL THREAD ZINC	F81002-5	5	
30	WASHER, 10.5 FLAT ZINC	F81055-1	8	
	WASHER, 10.5 FLAT ZINC	F81055-1	8	
	BOARD RETURN ASSEMBLY, LT70 <a href="#">See Section 4.3</a>	092757	1	

## 8.8 Bed Frame Decals

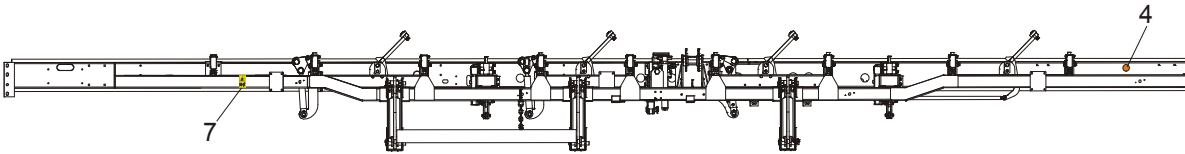
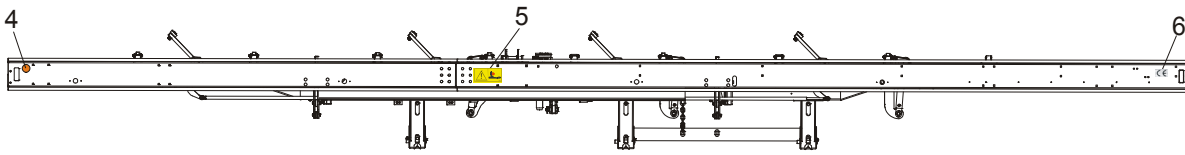
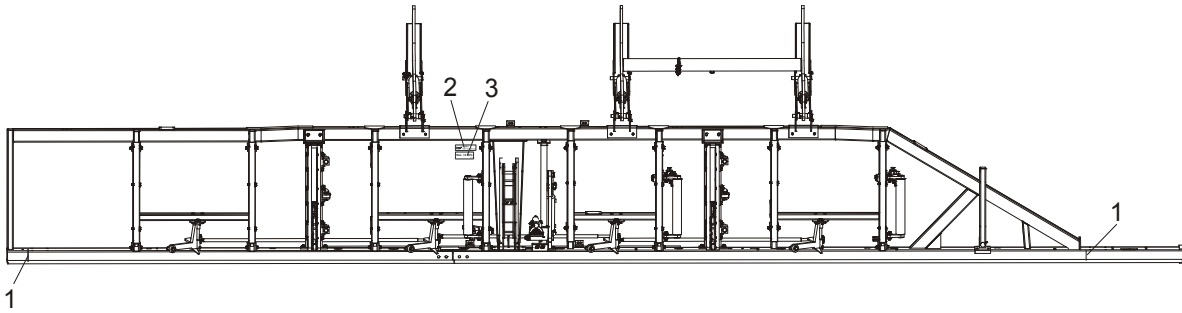

REF	DESCRIPTION (◆ Indicates Parts Available In Assemblies Only)	PART #	QTY.	
1	DECAL, LOG LENGTH LIMIT	S12051	2	
2	DECAL, HYDRAULIC OIL TYPE	096323	1	
3	DECAL, HYDRAULIC WORKING PRESSURE	099524	1	
4	DECAL, AMBER REFLECTIVE 2" ROUND	P07453	2	
5	DECAL, PINCH POINT DANGER, PICTOGRAM	099542	1	
6	DECAL, CE CERTIFIED SAWMILL, SMALL	P85070	1	
7	DECAL, KEEP AWAY DANGER, PICTOGRAM	099221	1	

8.9 LT40/LT70 L & LT70M Super Saw Head Support Assembly,

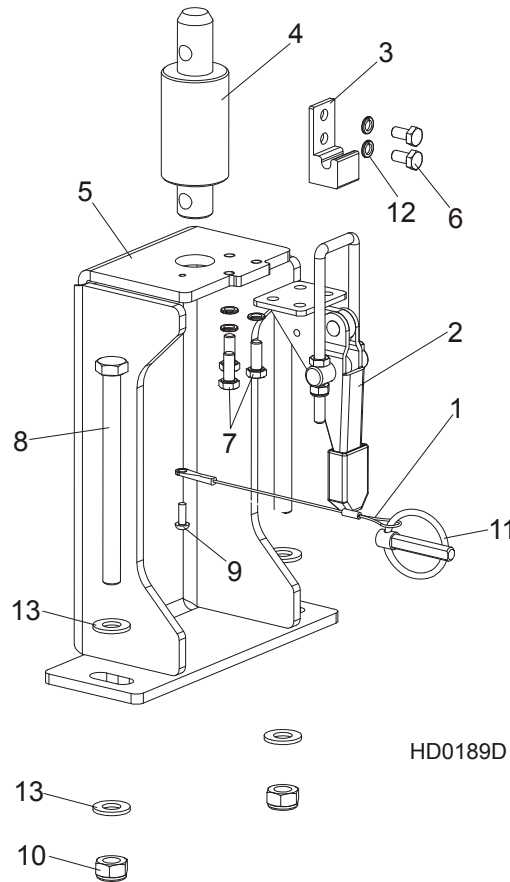

REF	DESCRIPTION (◆ Indicates Parts Available In Assemblies Only)	PART #	QTY.
	<b>SAW HEAD REST PIN W/LATCH CLAMP, LT70L</b>	<b>502392</b>	<b>1</b>
1	LANYARD, 3/64X6"	016030	1
2	CLAMP, GN851.2-320-T4 LATCH	094656	1
3	LATCH BRACKET, GN851.2-320-T4 ZINC-PLATED	094659-1	1
4	PIN, SAW HEAD REST LT20 PTD	097935-1	1
5	BRACKET, SAW HEAD REST	502389-1	1
6	BOLT, M6x12-8.8 HEX HEAD FULL THREAD ZINC	F81001-7	2
7	BOLT, M6 X 16 8.8 FE/ZN5 PN-M/82105	F81001-15	3
8	BOLT, M10x125-8.8 HEX HEAD ZINC	F81003-18	2
9	SCREW, M4x12 5,8-B CROSS RECESSED PAN HEAD	F81011-43	1
10	NUT, M10-8-B HEX NYLON ZINC LOCK	F81033-1	2
11	PIN, 8 BN914 (BOSSARD 134650) LOCK	F81046-2	1
12	WASHER, Z6.1 SPLIT LOCK ZINC	F81053-3	5
13	WASHER, 10.5 FLAT ZINC	F81055-1	4

**8** **BED FRAME ASSEMBLY**  
*Tie Down Chain Assembly*

**8.10 Tie Down Chain Assembly**

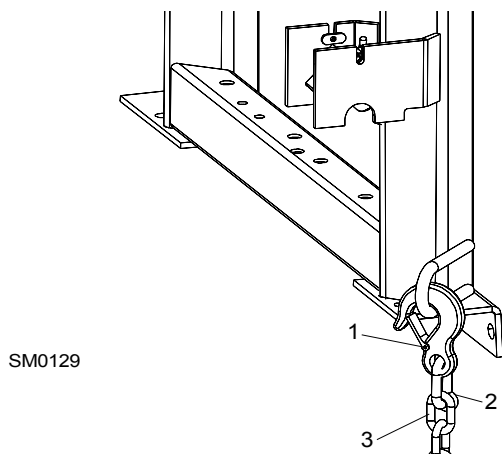

REF	DESCRIPTION (◆ Indicates Parts Available In Assemblies Only)	PART #	QTY.	
	<b>CHAIN ASSEMBLY, TIE DOWN</b>	A04376-1	1	
1	Hook, 5/8" Safety Chain	P12075	1	
2	Screw Closed Chain Link, 10	100767	1	
3	Chain, N-10 x 35, 6 Links	100951	1	

8.11 Remote Equipment Option

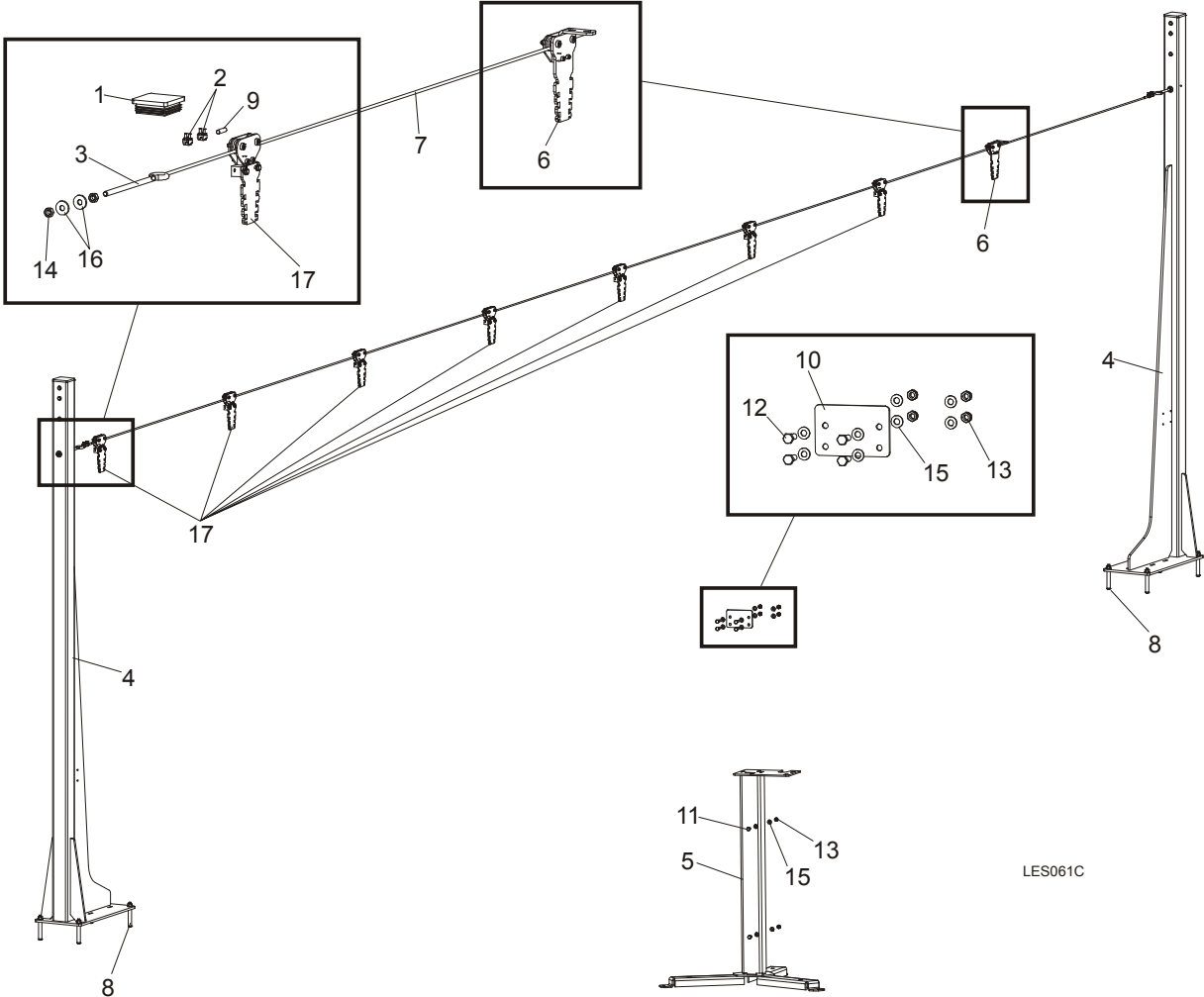

LES061C

REF	DESCRIPTION (◆ Indicates Parts Available In Assemblies Only)	PART #	QTY.
	<b>EQUIPMENT, LT20B REMOTE COMPLETE</b>	<b>501649</b>	<b>1</b>
1	CAP, EDGER FRAME	089644	2
2	CLAMP, LT20 STRING	091614	4
3	TENSIONER, ZINC-PLATED	500846-1	2
4	COLUMN, LT20B LINE GUIDE	503600-1	2
5	STAND, LT20B CONTROL BOX	501651-1	1
6	PULLEY, STATIONARY	504264	1
7	CABLE, 6MM (11,5 M) STEEL	504279	1
8	PIN, LT 16X120	501877	8
9	POINTER, 6MM STEEL CABLE	504280-1	2
10	CAP, LT20B REMOTE CONTROL BOX	501879-1	1
11	BOLT,M8X20-5.8 HEX HEAD FULL THREAD ZINC	F81002-1	2
12	BOLT, M8x25-8.8-B HEX HEAD FULL THREAD ZINC	F81002-5	4
13	NUT, M8-8-B HEX NYLON ZINC LOCK	F81032-2	6
14	NUT, M10-8-B-FE	F81033-3	4

**8****BED FRAME ASSEMBLY***Remote Equipment Option*

---

<b>15</b>	WASHER, 8.4 FLAT ZINC	F81054-1	12	
<b>16</b>	WASHER,10.5 ZINC FLAT SPECIAL	F81055-6	4	
<b>17</b>	PULLEY	504114	7	

## SECTION 9 HYDRAULIC SYSTEM

### 9.1 Hydraulic Hoses, LT70 AH14/15-ST

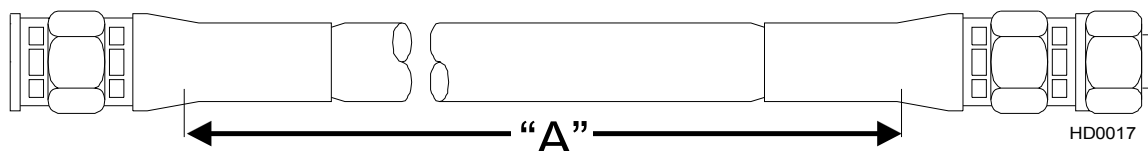

Green/Red	1,30	<b>3/8" TEE FITTING/3RD LOADER ARM, CYLINDER BOTTOM</b>	089808	2	
Green	2,20	<b>3/8" TEE FITTING/1ST LOADER ARM, CYLINDER BOTTOM</b>	091844	1	
Blue	1,20	<b>3/8" TEE FITTING/OIL FLOW DIVIDER</b>	504834	1	
None	10,20	<b>1/4" POWER ROLLER UP/DOWN</b>	506988	2	
Silver/Brown	9,70	<b>1/4" POWER ROLLER - ROLLER DRIVE - MOTOR</b>	506989	2	
None/Pink	7,20	<b>3/8" SIDE SUPPORTS UP/DOWN</b>	506990	2	
Brown/Cherry Red	3,75	<b>3/8" SIDE SUPPORTS TO LOG TURNER</b>	506991	2	
Red/Blue	9,75	<b>1/4" CONTROL BOX TO 2ND CLAMP UP/DOWN</b>	506992	2	
Orange/White	9,60	<b>1/4" CONTROL BOX TO 2ND CLAMP IN/OUT</b>	506993	2	
Green	9,00	<b>1/4" MIDDLE CLAMP TOP</b>	506994	1	
Yellow	8,70	<b>1/4" MIDDLE CLAMP BOTTOM</b>	506995	1	
White	7,77	<b>3/8" MIDDLE CLAMP FRONT END</b>	506996	1	
Orange	7,60	<b>3/8" MIDDLE CLAMP REAR END</b>	506997	1	
Cherry Red/Black	7,20	<b>1/4" 2ND TOE BOARD UP/DOWN</b>	506998	2	
Cherry Red/Black	5,90	<b>1/4" 1ST TOE BOARD UP/DOWN</b>	506999	2	
Red/Blue	6,90	<b>1/4" 1ST LOG CLAMP UP/DOWN</b>	507000	2	
Orange/White	6,00	<b>1/4" 1ST LOG CLAMP IN/OUT</b>	507001	2	
Blue/Red	7,60	<b>3/8" CONTROL BOX-LOG LOADER/LOG DECK</b>	507002	1	
Yellow	2,30	<b>3/8" TEE FITTING/1ST LOADER ARM, CYLINDER BOTTOM</b>	507003	1	
Yellow	0,90	<b>3/8" TEE FITTING/2ND LOADER ARM, CYLINDER TOP</b>	507004	1	
Yellow	1,35	<b>3/8" TEE FITTING/3RD LOADER ARM, CYLINDER TOP</b>	507005	1	
Blue	1,00	<b>3/8" TEE FITTING/TEE FITTING</b>	507006	1	
Green	0,80	<b>3/8" TEE FITTING/2ND LOADER ARM, CYLINDER BOTTOM</b>	507181	1	

# 9

## HYDRAULIC SYSTEM

Hydraulic Hoses, LT70 AH14/15-ST

### Protective Conduits, LT70L Super

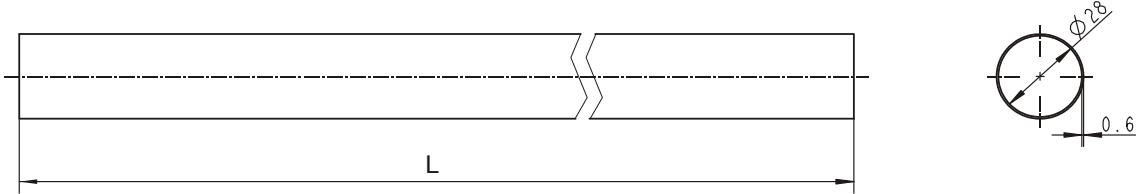

LENGTH "L"	DESCRIPTION (◆ Indicates Parts Available In Assemblies Only)	PART #	QTY.
0,70	PROTECTIVE CONDUIT, LOG TURNER HOSE	099761	2
0,80	PROTECTIVE CONDUIT, IN/OUT CYLINDER HOSE - BOTTOM	099762	1
0,80	PROTECTIVE CONDUIT, IN/OUT CYLINDER HOSE - TOP	099763	1
1,35	PROTECTIVE CONDUIT, UP/DOWN CYLINDER HOSE - BOTTOM	099764	1
1,65	PROTECTIVE CONDUIT, UP/DOWN CYLINDER HOSE - TOP	099765	1



9.2 Remote Control Box Parts

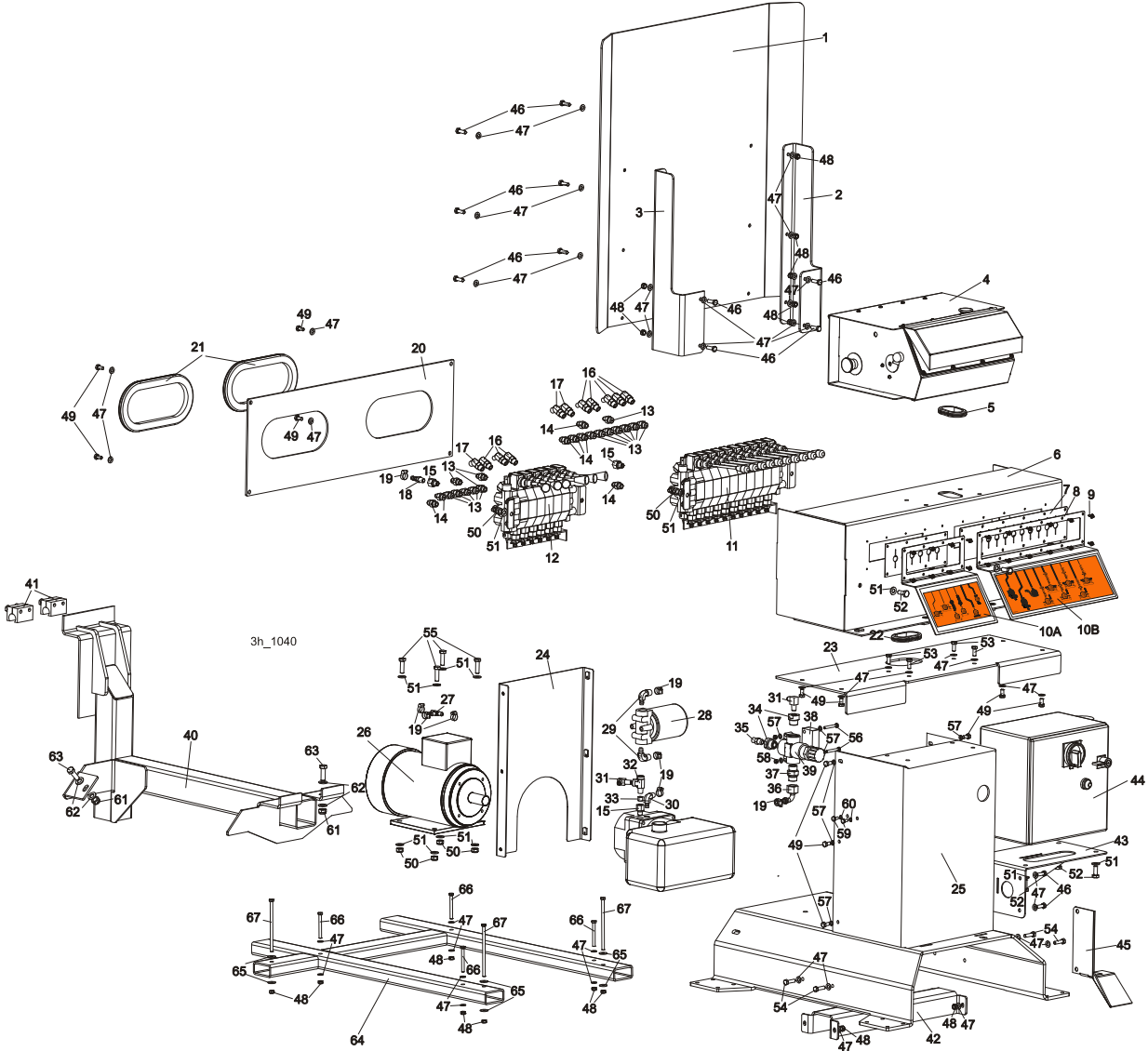

REF.	DESCRIPTION (◆ Indicates Parts Available In Assemblies Only)	PART #	QTY.
	<b>BOX, COMPLETE REMOTE 16-SECTION CONTROL</b>	<b>505272</b>	<b>1</b>
1	GUARD, LT70 CONTROL BOX PC	090219	1
2	BRACKET, CONTROL BOX GUARD RIGHT PTD	500766-1	1
3	BRACKET, CONTROL BOX GUARD LEFT PTD	500767-1	1
4	BOX, LT70 REMOTE CONTROL	093022	1
5	GROMMET, RUBBER	087065	1
6	HOUSING, HYDRAULIC VALVE - REMOTE CONTROL BOX - ST	505273-1	1
7	GUARD, RUBBER DOUBLE VALVE	015079	2
8	PLATE, RUBBER GUARD DOUBLE	015078	2
9	BOLT, #10-24X1/2 SELF-TAPPING	F05015-7	16

## 9

**HYDRAULIC SYSTEM***Remote Control Box Parts*

<b>10</b>	<b>DECAL ASSEMBLY, HYD. AH15 LT70 L AH Super</b>	<b>508594</b>	<b>1</b>	
10A	DECAL, hydraulic control 6-section	015364A4	1	
10B	DECAL, hydraulic control 9-section	094970S7	1	
<b>11</b>	VALVE, 6-SECTION HDS10/6-6	091344	1	
<b>12</b>	VALVE, 6-SECTION (FOR SERIES CONNECTION)	501104	1	
<b>13</b>	FITTING, 1/4JIC-3/8 O-RING	P26284	13	
<b>14</b>	FITTING, 3/8O-RING-3/8JIC	014687	10	
<b>15</b>	FITTING, 6SAE MALE-1/4NPT FEMALE	014686	3	
<b>16</b>	FITTING, #4JIC-#6SAE 45DEG ELBOW	015488	8	
<b>17</b>	FITTING, #6SAE 45DEG ELBOW	015489	3	
<b>18</b>	FITTING, 1/4NPT-3/8 BARB	014685	1	
<b>19</b>	CLAMP, 11/16 WORM	P12739	8	
<b>20</b>	PANEL, HYDRAULIC VALVE HOUSING REAR	500515-1	1	
<b>21</b>	GROMMET, RUBBER, 4 3/8 X 10 OVAL	085759	2	
<b>22</b>	GROMMET, RUBBER	087065	1	
<b>23</b>	PLATE, REMOTE CONTROL BOX PTD	500510-1	1	
<b>24</b>	PLATE, REMOTE CONTROL BOX REAR	500516-1	1	
<b>25</b>	PEDESTAL WLDMNT, REMOTE CONTROL BOX PTD	500509-1	1	
<b>26</b>	PUMP, AC.4KW 1.5L/MIN HYDRAULIC W/MOTOR	500958	1	
<b>27</b>	FITTING, 3/8 BARB TEE	015485	1	
<b>28</b>	MANIFOLD, W/FILTER	P22683	1	
<b>29</b>	FITTING, 1/2NPT-3/8 BARB ELBOW	P12707	2	
<b>30</b>	FITTING, 3/8NPT-3/8 BARB ELBOW	P12708	1	
<b>31</b>	FITTING, 3/8JIC-1/4NPT 90L	015491	2	
<b>32</b>	FITTING, 1/4NPT MALE RUN TEE	015486	1	
<b>33</b>	PLUG, TN 192-1/4NPT MALE THREAD	096221	1	
<b>34</b>	FITTING, M22X1.5 / 1/4 - 18 NPT REDUCER ZINC-PL.	093139-1	2	
<b>35</b>	FITTING, 3/8JIC-1/4NPT STRAIGHT	015560	1	
<b>36</b>	FITTING, PN10AFL 13-90 ELBOW	094485	1	
<b>37</b>	FITTING, VMNW10HS22 HYDRAULIC	094486	1	
<b>38</b>	WASHER, MTKA VALVE SPACER PTD	501099-1	1	
<b>39</b>	VALVE, MTKA.V8 OIL FLOW CONTROL	093794	1	
<b>40</b>	BRACKET, REMOTE CONTROL BOX TRANSPORT PTD ( <b>REMOTE BOX 500508</b> )	500292-1	1	
<b>41</b>	STOP, CARRIAGE SAFETY PAINTED (UKRAINE)	085973-1	2	
<b>42</b>	BRACE, CONTROL BOX PEDESTAL CROSS PTD	500763-1	1	
<b>43</b>	SHELF, ELECTRIC BOX COMPLETE	500518-1	1	
<b>44</b>	BOX, AC REMOTE ELECTRIC	087807	1	
<b>45</b>	SUPPORT, CABLES ROUTING (REMOTE)	501102-1	1	
<b>46</b>	BOLT, M8X25-8.8-B HEX HEAD FULL THREAD ZINC	F81002-5	14	
<b>47</b>	WASHER, 8.4 FLAT ZINC	F81054-1	56	
<b>48</b>	NUT, M8-8-B HEX NYLON ZINC LOCK	F81032-2	25	
<b>49</b>	BOLT, M8X16 -8.8-B HEX HEAD FULL THREAD ZINC	F81002-20	14	
<b>50</b>	NUT, M10-8-B HEX NYLON ZINC LOCK	F81033-1	8	

## HYDRAULIC SYSTEM

### Remote Control Box Parts

9

51	WASHER, 10.5 FLAT ZINC	F81055-1	20	
52	BOLT, M10X25-8.8 HEX HEAD FULL THREAD ZINC	F81003-11	8	
53	BOLT,M8X20-5.8 HEX HEAD FULL THREAD ZINC	F81002-1	4	
54	BOLT, M8X30-5.8 HEX HEAD FULL THREAD ZINC	F81002-2	4	
55	BOLT,M10X35-8.8 HEX HEAD FULL THREAD ZINC	F81003-17	4	
56	BOLT, M6X45-8.8 HEX HEAD ZINC	F81001-6	2	
57	WASHER, 6.4 FLAT ZINC	F81053-1	10	
58	NUT, M6-8-B HEX NYLON ZINC LOCK	F81031-2	2	
59	BOLT, 1/4-20 X 1/2 HEX HEAD ZINC GRADE 2	F05005-15	2	
60	WASHER, Z6.1 SPLIT LOCK ZINC	F81053-3	2	
61	NUT, M12-8 HEX NYLON ZINC LOCK	F81034-2	2	
62	WASHER, 13 FLAT ZINC	F81056-1	4	
63	BOLT, M12 X 35-8.8 HEX HEAD FULL THREAD ZINC	F81004-24	2	
64	BASE WLDMNT, ST CONTROL BOX TRANSPORT (L-TYPE FRAME, REMOTE BOX 505611 )	502378-1	1	
65	WASHER, 8.5 SPECIAL FLAT ZINC	F81054-11	6	
66	BOLT, M8x75 8.8 HEX HEAD ZINC	F81002-91	4	
67	BOLT, M8x160 -8.8-B HEX HEAD ZINC	F81002-22	3	

# 9 HYDRAULIC SYSTEM

## Hydraulic Log Loader, S/M Frame

### 9.3 Hydraulic Log Loader, S/M Frame

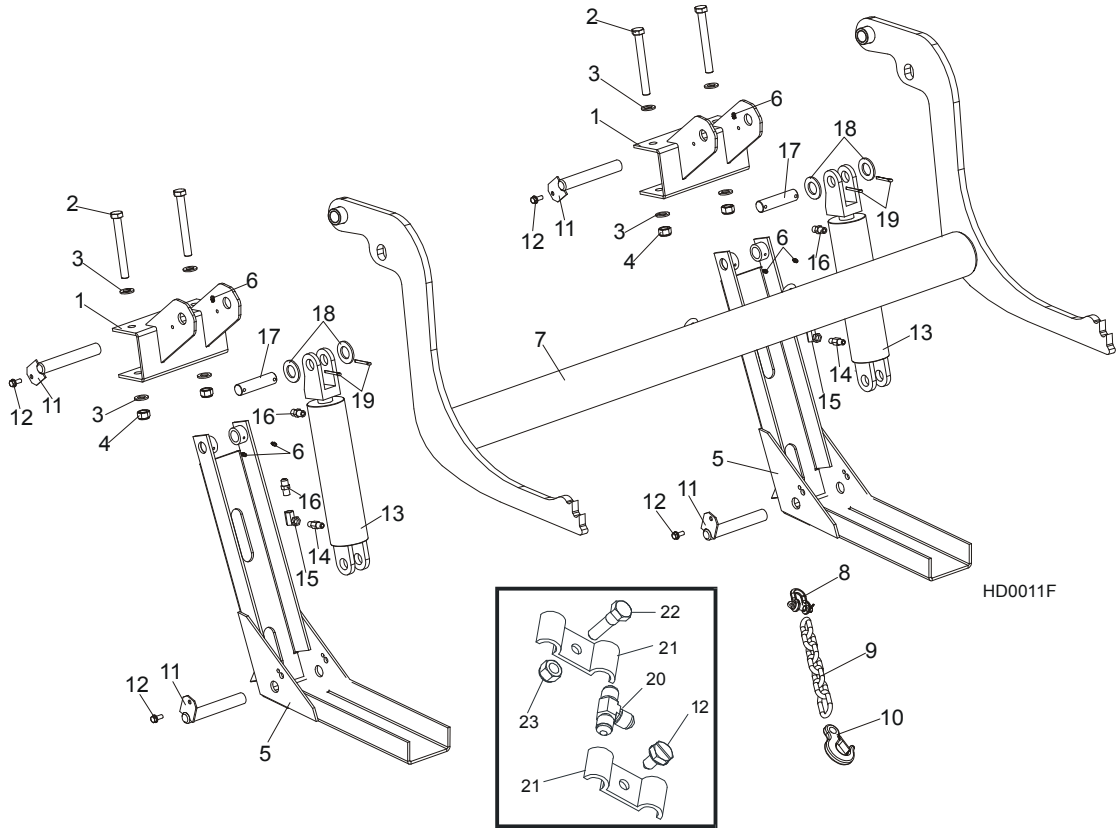

REF.	DESCRIPTION (◆ Indicates Parts Available In Assemblies Only)	PART #	QTY.
	<b>LOADER KIT, HYDRAULIC LOG, S/M FRAME</b>	<b>092863</b>	<b>1</b>
1	Bracket, Hydraulic Log Loader	087938-1	1
2	Bolt, M16x140-8.8 Hex Head Zinc	F81006-4	4
3	Washer, 17 Flat Zinc	F81058-1	8
4	Nut, M16-8 Hex Nylon Zinc Lock	F81036-2	4
5	Channel, Hydraulic Log Loading Foot Complete	090049	2
5	Channel, Hydraulic Log Loading Foot	090048-1	2
6	Fitting, 3/16x3/16 Straight Grease	P04107	6
7	Arm, Hydraulic Log Loading Complete	090044	1
7	Arm, Hydraulic Log Loading	090006-1	1
8	Shackle, M-WL. .63	086540	1
9	Chain, Hydraulic Log Loader Safety	A04376	1
10	Hook, 5/8 Safety Chain	P12075	1
11	Pin, Turner Arm	W09446-1	4
12	Screw, 5/16-18x3/4 Self-Tapping	F05015-30	4
	<b>Cylinder Assy, Log Loading Super</b>	<b>015562</b>	<b>2</b>
13	CYLINDER, CJ-S95-16-70/32/203 HYDRAULIC	088680	1
14	Fitting, 1/4NPT Velocity Fuse 5.0GPM	015750	2

<b>15</b>	Fitting, 1/4NPT-1/4JIC Swivel Elbow	P12199	2	
<b>16</b>	Fitting, 3/8JIC-1/4NPT Straight	015560	4	
<b>17</b>	Pin, Cylinder Hydraulic	086979-1	2	
<b>18</b>	Washer, 28 Flat Zinc	F81061-1	4	
<b>19</b>	Pin, 5x40 Cotter	F81043-31	4	
<b>20</b>	Fitting, 3/8 Barb Tee	015485	1	
<b>21</b>	Clamp, 3/8 Hose	016041	2	
<b>22</b>	Bolt, 5/16-18x1 Hex Head Zinc Grade 2	F05006-1	1	
<b>23</b>	Nut, 5/16-18 Nylon Zinc Lock	F05010-58	1	

**9.4 Hydraulic Log Turner**

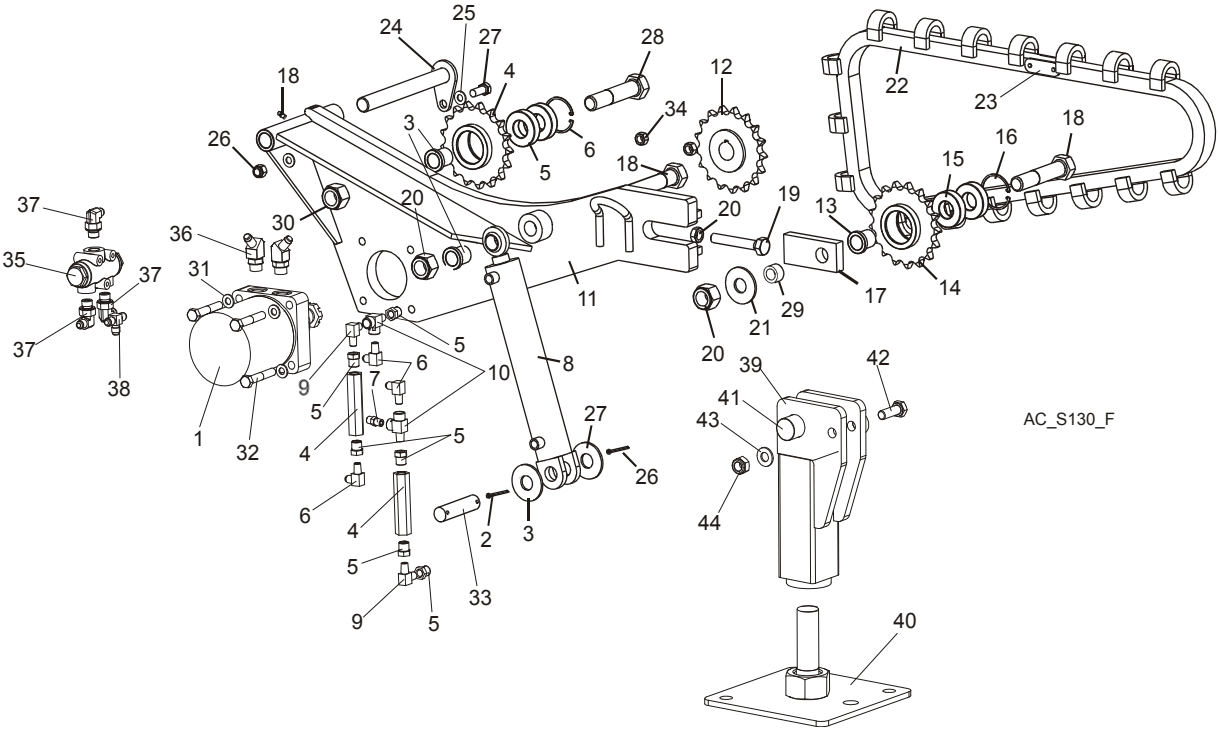

REF.	DESCRIPTION (◆ Indicates Parts Available In Assemblies Only)	PART#	QTY.	
	<b>CHAIN LOG TURNER - COMPLETE</b>	<b>505614</b>	<b>1</b>	
	<b>TURNER, CHAIN METRIC</b>	<b>095660</b>	<b>1</b>	
<b>1</b>	TURNER WELDMENT, HYDRAULIC CHAIN	095662-1	1	
<b>2</b>	SPROCKET, LOG TURNER	092339	1	
<b>3</b>	BUSHING, LOG TURNER	095663-1	3	
	<b>SPROCKET ASSEMBLY, LOG TURNER</b>	<b>092399</b>	<b>2</b>	
<b>4</b>	SPROCKET W/HUB	093290	1	

5	BEARING, 6206 25	093292	2	
6	RING, W62 INSIDE RETAINING	F81090-1	1	
7	PLATE, CHAIN TENSION	095664-1	1	
8	FITTING, M6 TYPE A GREASE	086280	1	
9	BOLT, M16x100-8.8 HEX HEAD FULL THREAD ZINC	F81006-2	1	
10	NUT, M16-5.8 HEX ZINC	F81036-1	1	
11	WASHER, 25X63 ZINC-PLATED	088585-1	1	
12	CHAIN, LOG TURNER	093423	1	
13	LINK, 093423 MASTER	093427	1	
14	PIN WELDMENT, TURNER MOUNT	095666-1	1	
15	WASHER, 10.5 FLAT ZINC	F81055-1	2	
16	NUT, M10-8-B HEX NYLON ZINC LOCK	F81033-1	1	
17	BOLT, M10x35-8.8 HEX HEAD FULL THREAD ZINC	F81003-17	1	
18	BOLT, M24x120 -8.8- PN-EN 24014	F81009-4	3	
19	BUSHING, CHAIN TURNER	095643-1	1	
20	NUT, M24-8-A HEX NYLON ZINC LOCK	F81039-8	3	
21	CYLINDER, 2" x 10" HYDRAULIC	034267	1	
22	MOTOR, TG0475US080AABP HYDRAULIC	007331	1	
23	BOLT, M12x75-8.8 HEX HEAD ZINC	F81004-21	4	
24	PIN, HYDRAULIC CYLINDER ZINC-PLATED	086979-1	1	
25	NUT, M12-8-B HEX ZINC	F81034-1	4	
26	PIN, S-Zn 5x40 COTTER ZINC	F81043-31	2	
27	WASHER, 28 FLAT ZINC	F81061-1	1	
	<b>HYDRAULIC CYLINDER CONNECTION PARTS</b>	<b>094383</b>	<b>1</b>	
28	DIVIDER, MTDA O8-016M 1/2 / 1/2 OIL FLOW	088191	1	
29	VALVE, SIDE SUPPORT SEQUENCE	015484	2	
30	FITTING, 3/8NPT NA 1/4NPT REDUCER	015490	6	
31	FITTING, 1/4NPT MALE PIPE ELBOW	P09140	2	
32	FITTING, 1/4NPT MALE RUN TEE	015486	2	
33	FITTING, #10SAE-3/8JIC 45 ELBOW	034538	2	
34	FITTING, 90 18x1.5 9/16-18 JIC ELBOW	089992	3	
35	FITTING, 3/8JIC TEE	015487	1	
36	FITTING, 3/8JIC-1/4NPT 90L	015491	3	
37	FITTING, 3/8JIC-1/4 NPT STRAIGHT	015560	1	
	<b>SUPPORT, LOG TURNER - COMPLETE</b>	<b>099975</b>	<b>1</b>	
38	BRACKET, CHAIN TURNER SUPPORT UPPER	099932-1	1	
39	FOOT, CHAIN TURNER SUPPORT ZINC-PLATED	099969-1	1	
40	PIN WELDMENT, TURNER SUPPORT MOUNT ZINC-PL.	099970-1	1	
41	BOLT, M10x30-5.8 HEX HEAD FULL THREAD ZINC	F81003-2	1	
42	WASHER, 10.5 FLAT ZINC	F81055-1	1	
43	NUT, M10-8-B HEX NYLON ZINC LOCK	F81033-1	1	

**9.5 Hydraulic Log Clamp, Front and Rear**

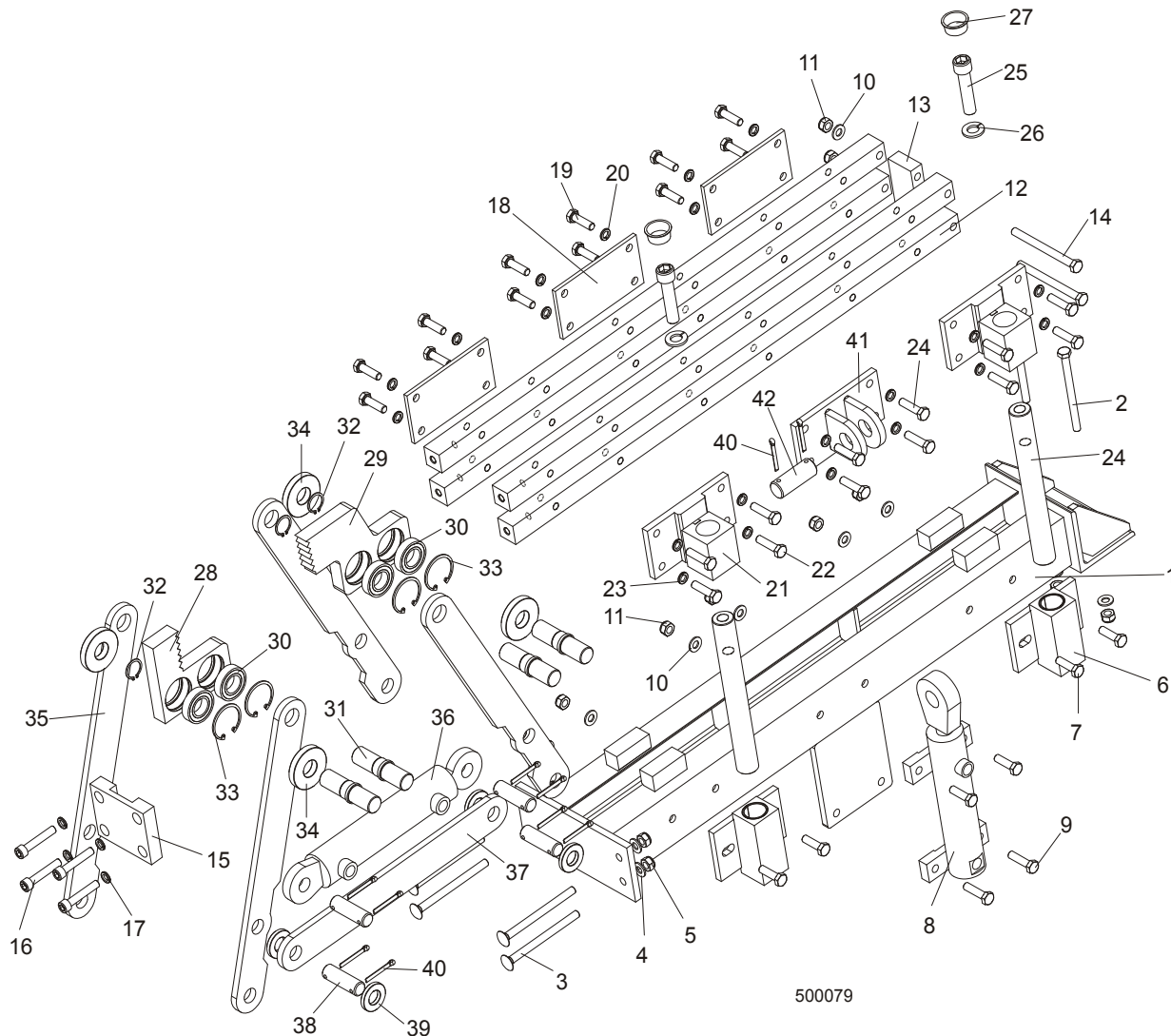

500079

REF.	DESCRIPTION (◆ Indicates Parts Available In Assemblies Only)	PART #	QTY.
	<b>CLAMP ASSEMBLY, HYDRAULIC</b>	<b>089545</b>	<b>2</b>
1	Mount Weldment, Hydraulic Log Clamp	088654-1	1
2	Bolt, M10x125-8.8 Zinc Hex Head	F81003-18	2
3	Bolt, M10x130-8.8 Zinc Mushroom Head Square Neck	F81003-36	4
4	Washer, 10.5 Flat Zinc	F81055-1	6
5	Nut, M10-8-B Hex Nylon Zinc Lock	F81033-1	6
6	Block, Guide Pin	089835-1	2
7	Bolt, M10x35-8.8 Zinc Hex Head Full Thread	F81003-17	4
8	Cylinder, CJ7F-16-40/22 + UE2-40W Hydraulic	088662	1
9	Bolt, M10x40-8.8 Zinc Hex Head	F81003-16	4
10	Washer, M10 Flat Zinc	F81055-1	6

## 9

**HYDRAULIC SYSTEM***Hydraulic Log Clamp, Front and Rear*

11	Nut, M10-8-b Hex Nylon Zinc Lock	F81033-1	10	
12	Bar, Clamp Up/Down	089537-1	4	
13	Plate, Connecting	088645-1	1	
14	Bolt, M10x140-8.8 Zinc Hex Head	F81003-5	2	
15	Plate, Connecting	089533-1	1	
16	Bolt, M10x55-8.8 Zinc Hex Socket Head Cap	F81003-55	4	
17	Washer, 10.2 Split Lock Zinc	F81055-2	4	
18	Plate, Log Clamp Rear	089538-1	3	
19	Bolt, M10x35-8.8 Zinc Hex Head Full Thread	F81003-17	12	
20	Washer, 10.2 Split Lock Zinc	F81055-2	12	
21	Bracket, Guide Pin Mount	089536-1	2	
22	Bolt, M10x40-8.8 Zinc Hex Head Full Thread	F81003-16	8	
23	Washer, 10.2 Split Lock Zinc	F81055-2	8	
24	Pin, Clamp Up/Down Guide	088631	2	
25	Screw, M16x55-8.8 Zinc Hex Socket Head Cap	F81006-18	2	
26	Washer, 16.3 Split Lock Zinc	F81058-2	2	
27	Plug, M33 Thread	089839	2	
	<b>Jaw, Log Clamp Left - Complete</b>	<b>094700</b>	1	
28	Jaw, Log Clamp Left	093464-1	1	
30	Bearing, 6005 2RS CX	089652	4	
31	Shaft, Clamp Jaw Guide	088620-1	4	
32	Ring, Z24 Spring Retaining	089654	4	
33	Ring, W47 Spring Retaining	089653	4	
	<b>Jaw, Log Clamp Right - Complete</b>	<b>094701</b>	1	
29	Jaw, Log Clamp Right	093465-1	1	
30	Bearing, 6005 2RS CX	089652	4	
31	Shaft, Clamp Jaw Guide	088620-1	4	
32	Ring, Z24 Spring Retaining	089654	4	
33	Ring, W47 Spring Retaining	089653	4	
34	Washer, Clamp Jaw Spacer	089542	4	
35	Bar, Clamp In/Out Side	088622-1	4	
36	Cylinder, SJ2F-40/22/145 Hydraulic	088661	1	
37	Bar, Clamp In/Out Lower	088623-1	1	
38	Pin, 20X75	088657-1	4	
39	Spacer, Lower	089541	4	
40	Pin, S-Zn 5x40 Cotter	F81043-31	10	
41	Bracket, Vertical Cylinder Mount Upper	089540-1	1	
42	Pin, 25X75	088659-1	1	



**9.6 Hydraulic Log Clamp, Additional**

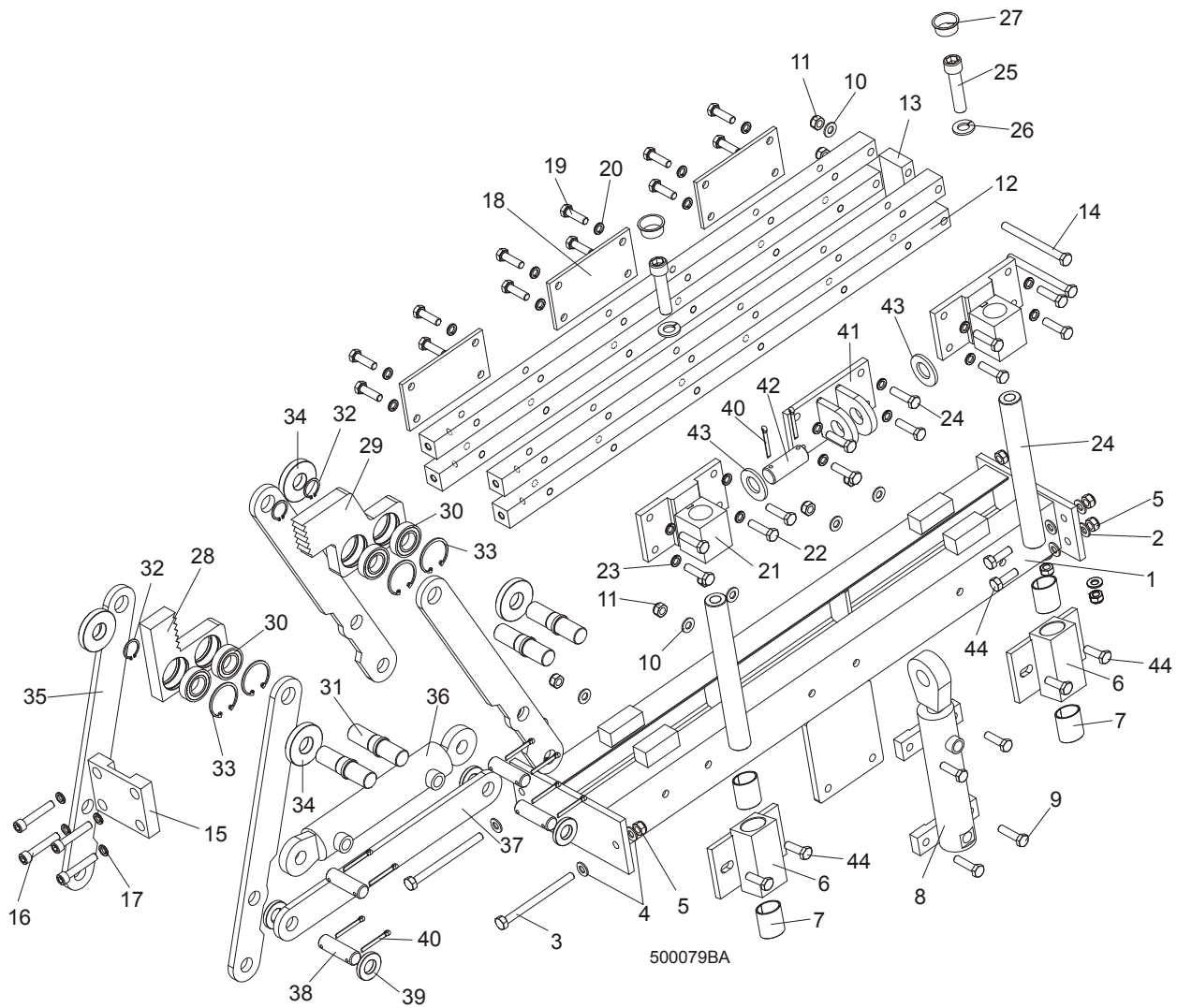

REF.	DESCRIPTION (◆ Indicates Parts Available In Assemblies Only)	PART #	QTY.
	<b>HYDRAULIC LOG CLAMP ASSEMBLY</b>	<b>094950</b>	<b>2</b>
1	Mount Weldment, Hydraulic Log Clamp	094951-1	1
2	Washer, M10 Split Lock Zinc	F81055-2	4
3	Bolt, M10x125-8.8 Zinc Hex Head	F81003-18	2
4	Washer, 10.5 Flat Zinc	F81055-1	6
5	Nut, M10-8-B Hex Nylon Zinc Lock	F81033-1	6
6	Block Weldment, Log Clamp Guide Painted	089835-1	2
	<b>LOG CLAMP GUIDE BLOCK</b>	<b>089835</b>	<b>2</b>
7	Block Weldment, Log Clamp Guide Ptd	088652-1	1
8	Bushing, 3040BS Self-lubricating	088676	2



## HYDRAULIC SYSTEM

### *Hydraulic Log Clamp, Additional*

9	Cylinder, CJ7F-16-40/22 + UE2-40W Hydraulic	088662	1	
10	Bolt, M10x40-8.8 Hex Head Full Thread Zinc	F81003-16	4	
11	Washer, 10.5 Flat Zinc	F81055-1	6	
12	Nut, M10-8-B Hex Nylon Zinc Lock	F81033-1	10	
13	Bar, Log Clamp Main Painted	089537-1	4	
14	Block, Main Bar Spacer Painted	088645-1	1	
15	Bolt, M10x120-8.8 Hex Head Zinc	F81003-47	2	
16	Plate Weldment, Main Bar Mounting Painted	089533-1	1	
17	Screw, M10x40-8.8 Hex Socket Head Cap Zinc	F81003-22	4	
18	Washer, 10.2 Split Lock Zinc	F81055-2	4	
19	Plate, Log Clamp Rear Painted	089538-1	3	
20	Bolt, M10x35-8.8 Hex Head Full Thread Zinc	F81003-17	12	
21	Washer, 10.2 Split Lock Zinc	F81055-2	12	
22	Block Weldment, Log Clamp Up/Down Upper	089536-1	2	
23	Bolt, M10x40-8.8 Hex Head Full Thread Zinc	F81003-16	8	
24	Washer, 10.2 Split Lock Zinc	F81055-2	8	
25	Pin, Log Clamp Up/Down	088631	2	
26	Screw, M16x55-8.8 Hex Socket Head Cap Zinc	F81006-18	2	
27	Washer, 16.3 Split Lock Zinc	F81058-2	2	
28	Plug, M33 Thread	089839	2	
	<b>Jaw, Log Clamp Narrow - Complete</b>	<b>094700</b>	1	
29	Jaw, Log Clamp Narrow	093464-1	1	
30	Bearing, 6005 2RS CX	089652	4	
31	Shaft, Log Clamp Jaw	088620-1	4	
32	Ring, Z24 Outside Retaining	089654	4	
33	Ring, W47 Inside Retaining	089653	4	
	<b>Jaw, Log Clamp Wide - Complete</b>	<b>094701</b>	1	
29	Jaw, Log Clamp Wide	093465-1	1	
30	Bearing, 6005 2RS CX	089652	4	
31	Shaft, Log Clamp Jaw	088620-1	4	
32	Ring, Z24 Outside Retaining	089654	4	
33	Ring, W47 Inside Retaining	089653	4	
34	Washer, Clamp Jaw Spacer	089542	4	
35	Arm, Log Clamp In/Out Painted	088622-1	4	
36	Cylinder, SJ2F-40/22/145 Hydraulic	088661	1	
37	Link, Log Clamp In/Out Arm Painted	088623-1	1	
38	Pin, 20x75 Zinc-Plated	088657-1	4	
39	Washer, Lower Spacer	089541	4	
40	Washer, 21 Flat Zinc	F81059-2	10	
41	Bracket, Up/Down Cylinder Mount Upper	089540-1	1	
42	Pin, 25x75 Zinc-Plated	088659-1	1	
43	Washer 28 Flat Zinc	F81061-1	2	
44	Bolt, M10x35-8.8 Hex Head Full Thread Zinc	F81003-17	8	

**9.7 Hydraulic Log Clamp**

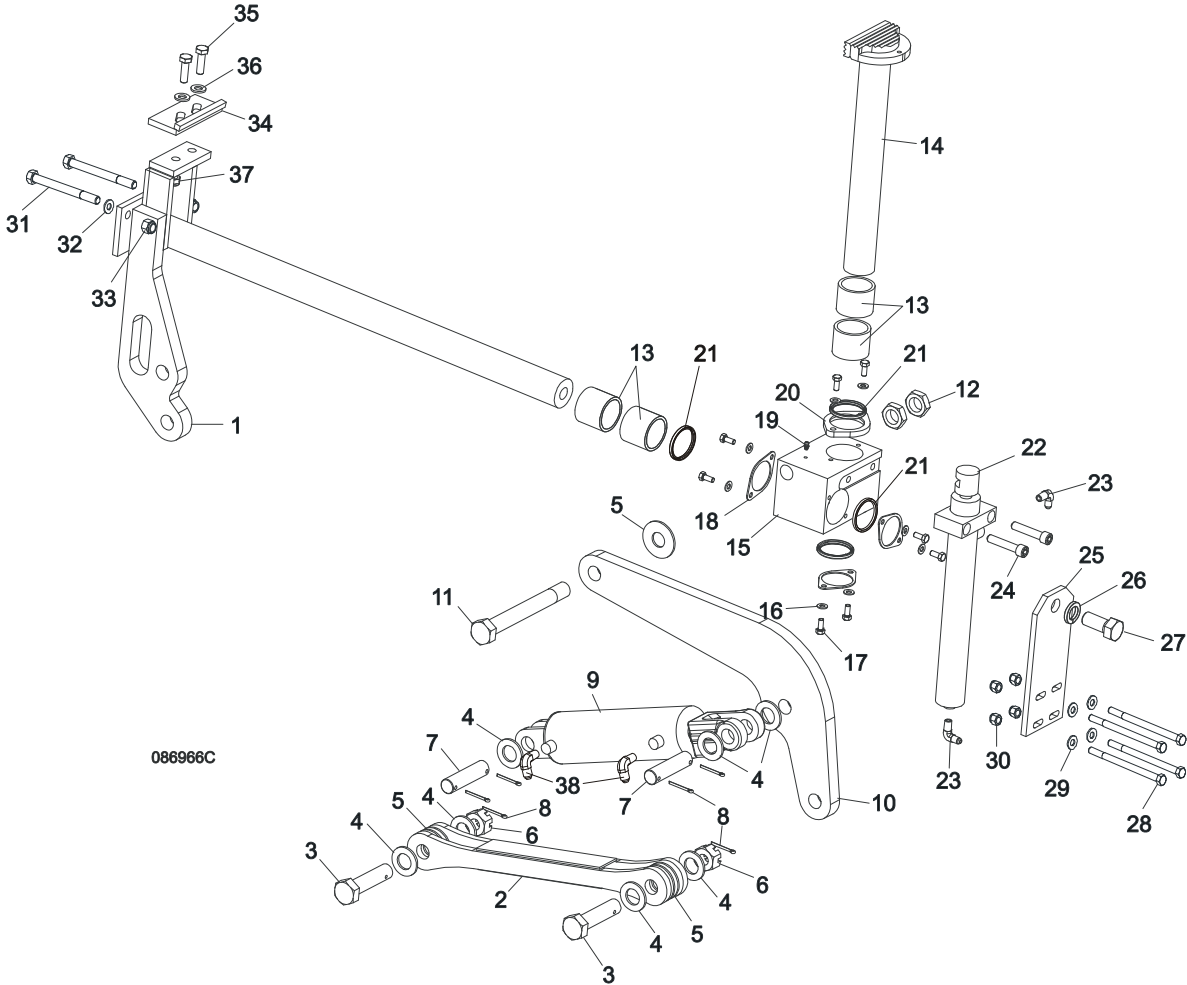

REF.	DESCRIPTION (◆ Indicates Parts Available In Assemblies Only)	PART #	QTY.
	<b>HYDRAULIC LOG CLAMP ASSEMBLY</b>	<b>088658</b>	<b>1</b>
1	Rod Weldment, Log Clamp Slide Ptd	086967-1	1
2	Arm Weldment, Hydraulic Clamp Link Ptd	086963-1	1
3	Pin, B 24x95/85-Clevis Zinc	F81049-2	1
4	Washer, 25 Flat Zinc	F81061-3	8
5	Washer, 25X63 Zinc-Plated	088585-1	5
6	Nut, Z M20-8-B-Slotted Castle Zinc	F81037-3	2
7	Pin, Hydraulic Cylinder Zinc-Plated	086979-1	2
8	Pin, S-Zn 6,3x45 Cotter	F81045-2	6
9	Cylinder, CJ-S96-16-70/32/178 Hydraulic	088589	1
10	Arm, Hydraulic Log Clamp Link Ptd	086974-1	1
11	Bolt, M24x217/39 -8.8-B- Hex Head Zinc	088586-1	1
12	Nut, M24 -04-B- Hex Thin Zinc	F81039-3	2
13	Bushing, 5040BS Self-Lubricating	088660	2

14	Rod Weldment, Log Clamp Vertical Painted	088582-1	1	
15	Block, Log Clamp Steel Ptd	088591-1	1	
16	Washer, 8.4 Flat Zinc	F81054-1	8	
17	Bolt, M8x20-8.8-B-Hex Head Full Thread Zinc	F81002-4	8	
18	Flange, Clamp Rod Wiper Ptd	088887-1	3	
19	Fitting, 3/16" Straight Grease	P04107	1	
20	Flange, Clamp Rod Wiper Ptd	088887-1	1	
21	Wiper, ZZ 50x60x7 Log Clamp Rod	088587	1	
22	Cylinder, CJ-S169-16-40/22/254 Hydraulic	088590	1	
23	Fitting, 1/4" NPT - 1/4" JIC Male Elbow	P09142	2	
24	Screw, M12x55 -8.8-B-Hex Socked Head Cap Zinc	F81004-23	2	
25	Plate, Log Clamp Mount Ptd	086975-1	1	
26	Washer, Z 22,5 Split Lock	F81059-4	1	
27	Bolt, M22x1,5x40 -8.8-B-Hex Head Full Thread Zinc	F81009-1	1	
28	Bolt, M10 x 125-8.8 Hex Head Zinc	F81003-18	4	
29	Washer, 10.5 Flat Zinc	F81055-1	8	
30	Nut, M10-8-B Hex Nylon Zinc Lock	F81033-1	4	
31	Bolt, M12x130-8.8-Hex Head Zinc	F81004-36	2	
32	Washer, 13 Flat Zinc	F81056-1	2	
33	Nut, M12-8 Hex Zinc	F81034-1	2	
	<b>STOP KIT, CLAMP</b>	K09485	1	
34	Stop Wldmt, Hydraulic Log Clamp Ptd	086980-1	1	
35	Bolt, M12 x 40 8.8 Hex Head Full Thread Zinc	F81004-4	2	
36	Washer, 13 Flat Zinc	F81056-1	2	
37	NUT, M12-8 HEX NYLON ZINC LOCK	F81034-2	4	
38	FITTING, 3/8JIC-1/4NPT 90L	015491	2	

9.8 Hydraulic Log Side Supports (for Stationary Sawmills)

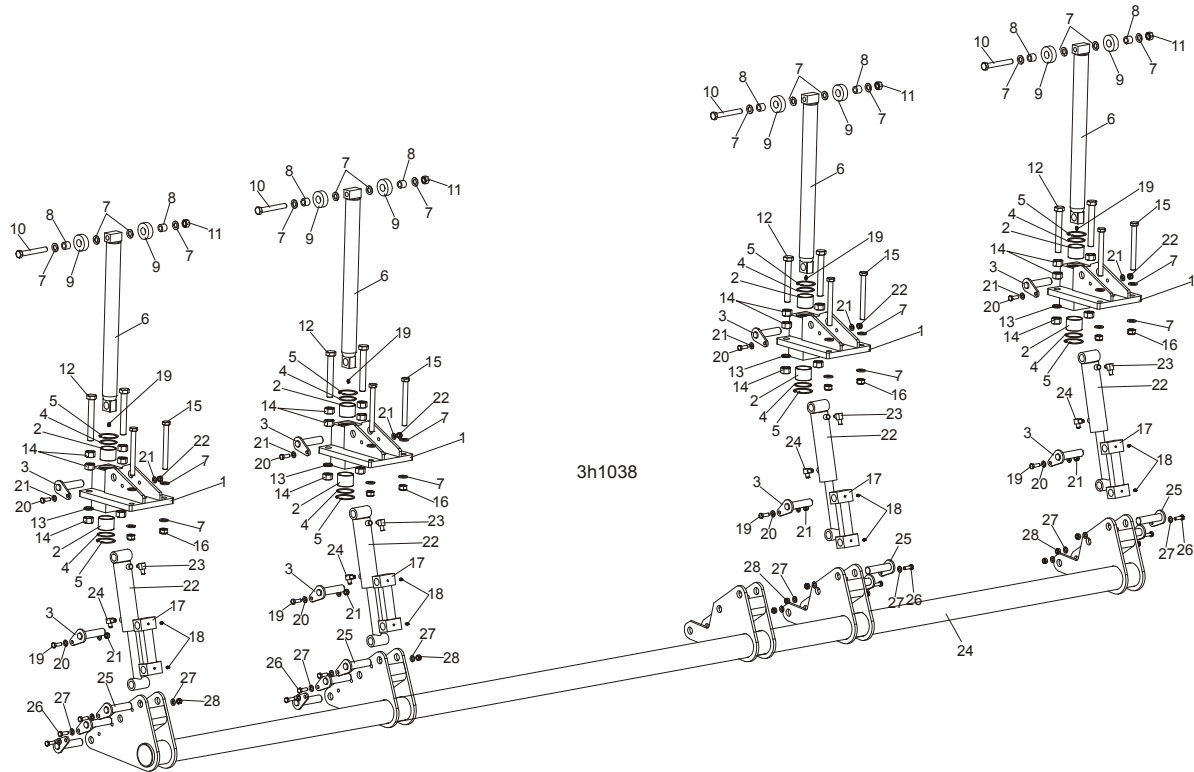

REF.	DESCRIPTION (◆ Indicates Parts Available In Assemblies Only)	PART#	QTY.
	<b>ASSEMBLY 4 VERTICAL SIDE SUPPORT COMPLETE</b>	<b>503567</b>	<b>1</b>
	SUPPORT, STATIONARY VERTICAL LOG SIDE	<b>097519</b>	<b>4</b>
1	Mount Weldment, LT70/300 Vertical Side Support Upper	094003-1	1
2	Bushing, 5040BS Non-Greasable	088660	2
3	Pin Weldment, Vertical Side Support Zinc-Plated	091197-1	2
4	Ring, LT70/300 Vertical Side Support Zinc-Plated	094004-1	2
5	Ring, 62W Inside Retaining	F81090-1	2
6	Rod Weldment, LT70/300 Vertical Side Support Complete	094011-1	1
7	Washer, 17 Flat Zinc	F81058-1	12
8	Bushing, LT70/300 Vertical Side Support Bronze	094012	2
9	Roller, LT70/300 Vertical Side Support Zinc-Plated	094013-1	2
10	Bolt, M16x120 -8.8 Hex Head Zinc	F81006-25	1
11	Nut, M16-5.8 Hex Zinc	F81036-1	1
12	Bolt, ISO 4017 M20x150 8.8 Zinc-Plated	F81007-3	2
13	Washer, 20.5 Split Lock Zinc	F81059-1	2
14	Nut, M20-8 Hex Zinc	F81037-1	6
15	Bolt, M16x160 -8.8 Hex Head Zinc	F81006-20	2
16	Nut, M16-8 Hex Nylon Zinc Lock	F81036-2	2
17	Link Weldment, LT300 Vertical Side Support	094016-1	1

## 9

**HYDRAULIC SYSTEM***Hydraulic Log Side Supports (for Stationary Sawmills)*

18	Fitting, M6 Grease	086280	3	
19	Bolt, M10x30-5.8 Hex Head Full Thread Zinc	F81003-2	2	
20	Washer, 10.5 Flat Zinc	F81055-1	4	
21	Nut, M10-8-B Nylon Hex Zinc Lock	F81033-1	2	
22	Cylinder, 28/150 1/4 NPT Port Hydraulic	094002	1	
23	Fitting, 3/8JIC-1/4NPT 90L	015491	2	
24	Mount Weldment, Vertical Side Support Lower	503568-1	1	
25	Pin Weldment, Vertical Side Support Zinc-Plated	091197-1	12	
26	Bolt, M10x30-5.8 Hex Head Full Thread Zinc	F81003-2	12	
27	Washer, 10.5 Flat Zinc	F81055-1	24	
28	Nut, M10-8-B Nylon Hex Zinc Lock	F81033-1	12	

9.9 Hydraulic Toe Board

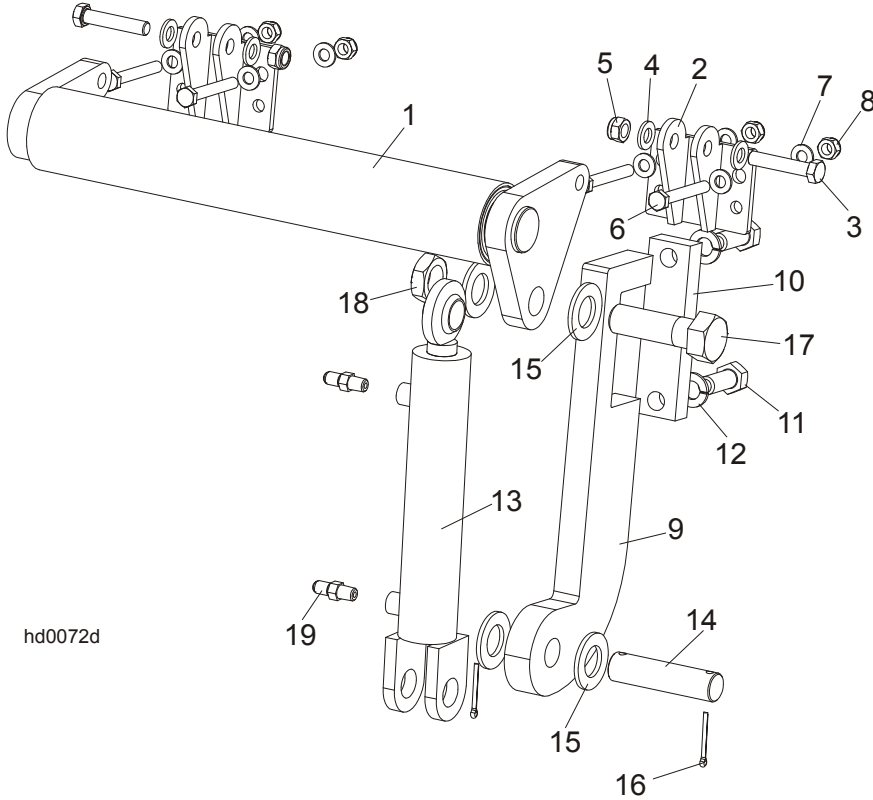

hd0072d

REF.	DESCRIPTION (◆ Indicates Parts Available In Assemblies Only)	PART#	QTY.
	<b>HYDRAULIC TOE BOARD - FRONT</b>	<b>092613</b>	<b>1</b>
	<b>HYDRAULIC TOE BOARD - REAR</b>	<b>092634</b>	<b>1</b>
1	Toe Board Weldment, Hydraulic - Rear	086253-1	1
2	Bracket, Hydraulic Toe Board	087903-1	4
3	Bolt, M12x60mm Hex Head Zinc Grade 8.8	F81004-5	4
4	Washer, M12 Flat Zinc	F81056-1	8
5	Nut, M12 Hex Nylon Zinc Lock	F81034-2	4
6	Bolt, M10x75-8.8 Hex Head Zinc	F81003-15	8
7	Washer, M10 Flat Zinc	F81055-1	16
8	Nut, M10 Hex Nylon Zinc Lock	F81033-1	8
9	Bracket, Hydraulic Toeboard Mount	087729-1	2
10	Plate, Hydraulic Toeboard Mount	090086-1	2
11	Bolt, M16x40mm Hex Head Full Thread Zinc Grade 5.8	F81006-13	4
12	Washer, 16.3 Split Lock Zinc	F81058-2	4
13	Cylinder, CJ-S170-16-40/25/152 Hydraulic	088681	2
14	Pin, Cylinder Mount	086979-1	2
15	Washer, 28 Flat Zinc	F81061-1	8
16	Pin, 3/16x1.5 Cotter Zinc	F05012-23	4
17	Bolt, 1-8x3 1/4 Hex Head Grade 5	F05009-51	2

# 9 HYDRAULIC SYSTEM

## Power Roller

18	Nut, 1-14 Hex Jam Unplated	F05010-117	2	
19	Fitting, 1/4NPTx1/4JIC Male	P09143	4	

### 9.10 Power Roller

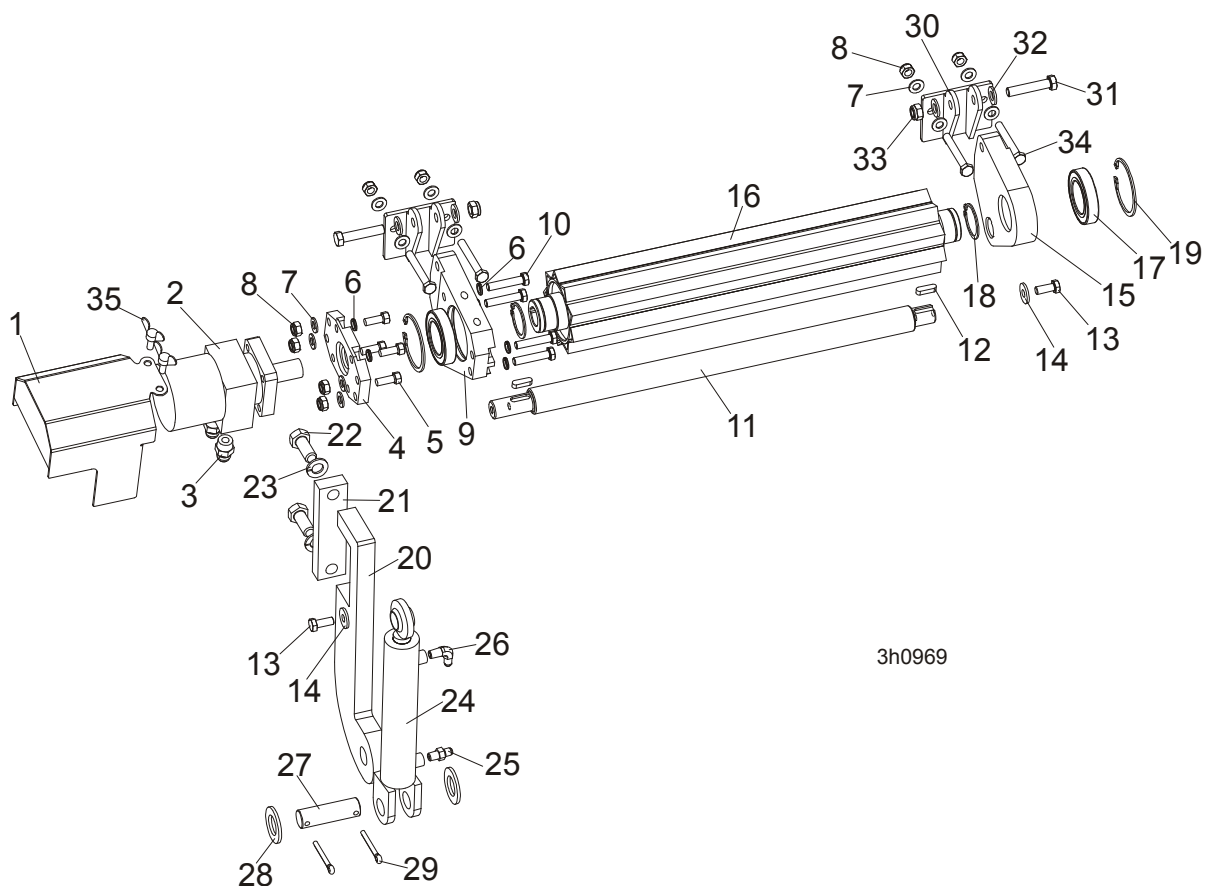

REF.	DESCRIPTION (◆ Indicates Parts Available In Assemblies Only)	PART#	QTY.	
	<b>POWER ROLLER</b>	<b>507649</b>	<b>1</b>	
1	Cover, Hydraulic Motor	096037-1	1	
2	Motor, MG06-13-13AAAB Hyd	P21506	1	
3	Fitting, 1/2-14NPT/ 7/16-20UNF	096919	2	
4	Plate, Hydraulic Motor Mount	096030-1	1	
5	Screw, 3/8-16x1, HHC	F05007-7	4	
6	Washer, 10.2 Split Lock Zinc	F81055-2	4	
7	Washer, 10,5 Flat Zinc	F81055-1	12	
8	Nut, M10-8-B Nylon Hex Zinc Lock	F81033-1	8	
9	Bracket, Side w/HydroMotor Connector	096029-1	1	
10	Bolt, M10x50-8.8-Hex Head Full Thread Zinc	F81003-4	4	
11	Rod	096034	1	
12	Key, A8x7x28 Parallel	096035	2	



13	Bolt, M10x25 8.8 Hex Head Full Thread Zinc	F81003-31	2	
14	Washer, 10,5 Zinc Flat Special	F81055-6	2	
15	Bracket	096031-1	1	
16	Roller, Pivot - Wldmt	096028-1	1	
17	Bearing, 6009.2RSR	096025	2	
18	Ring, Z 45 Spring Retaining	F81090-32	2	
19	Ring, W 75 Spring Retaining	F81090-41	2	
20	BRACKET, HYDRAULIC TOE BOARD MOUNT	089990-1	1	
21	Plate, Hydraulic Toe Board Mount	090086-1	1	
22	Bolt, M16x40-8.8 Hex Head Full Thread Zinc	F81006-13	2	
23	Washer, 16,3 Split Lock Zinc	F81058-2	2	
	Cylinder, Hydraulic Toe Boards	085937	1	
24	Cylinder, CJ-S170-16-40/25/152 Hydraulic	088681	1	
25	Fitting, C5205x4x4 Male	P09143	1	
26	Fitting, 1/4NPTx1/4JIC Male Elbow	P09142	1	
27	Pin, Hydraulic Cylinder Zinc	086979-1	1	
28	Washer, 28 Flat Zinc	F81061-1	2	
29	Pin, S-Zn 6,3x45	F81045-2	2	
30	Bracket, Toe Board Roller Mount	087903-1	2	
31	Bolt, M12x60-8.8 Hex Head Zinc	F81004-5	2	
32	Washer, 13 Zinc Flat	F81056-1	4	
33	Nut, M12-8 Hex Nylon Zinc Lock	F81034-2	2	
34	Bolt, M10x75-8.8-Hex Head Zinc	F81003-15	4	
35	Stud, M6x16 Wing	F81001-16	2	