



user manual

Instrukcja obsługi | Руководство пользователя
Manuel de l'Utilisateur | Betriebsanweisung
Bruksanvisning | Manual del Usuario
Betjeningsvejledning | Gebruikershandleiding
Käyttöohjeet | Manual de utilizare | Bruksanvisning
Manuale d'uso | Příručka uživatele | Navodila
za uporabo

Retain for future use
Zachować do przyszłego użytku
Сохраните для последующего
использования
A conserver pour une utilisation future
Für zukünftige Benutzung aufbewahren
Behold for senere bruk
Säilytä nämä käyttöohjeet tulevaa tarvetta marten
Opbevar manualen til fremtidig brug
Bewaren voor gebruik in de toekomst
Conservare il presente manuale a l'uso futuro
Păstrați acest manual pentru utilizare viitoare
Conservar para futuras consultas
Behall för framtida användning
Uchovejte pro další použití
Hranite za prihodnjo uporabo

Wood-Mizer®

Safety, Setup, Operation & Maintenance Manual

LT70M AH Super

rev. A9.00



Safety is our #1 concern! Read and understand all safety information and instructions before operating, setting up or maintaining this machine.

August 2006

Form #1059

**This is the original language
for the manual.**

Table of Contents

Section-Page

SECTION 1	SAFETY & GENERAL INFORMATION	1-1
1.2	Blade Handling.....	1-2
1.3	Sawmill Setup.....	1-2
1.4	Sawmill Operation.....	1-3
1.5	Sawmill Maintenance	1-5
1.6	Safety Instructions	1-5
1.7	Belt Sizes	1-11
1.8	Blade Sizes	1-16
1.9	Cutting Capacity	1-16
1.10	Engine/Motor Specifications	1-17
1.11	Noise Level.....	1-18
1.12	Overall Dimensions	1-18
1.13	Chains.....	1-19
1.14	Hydraulic system.....	1-19
1.15	Dust Extractor Specifications	1-20
1.16	Components.....	1-20
1.17	LT40/70 S/M AH Hydraulic Schematic	1-22
1.18	LT40/70 S/M AH Hydraulic Components	1-23
1.19	LT40/70 S/M Hydraulic Hoses	1-24
1.20	Hydraulic Blade Tensioner Assembly.....	1-26
SECTION 2	SETUP & OPERATION	2-1
2.1	Sawmill Setup.....	2-1
2.2	Stationary Sawmill Setup	2-3
2.3	Portable Sawmill Setup	2-9
2.4	Middle track cover.....	2-11
2.5	Replacing The Blade	2-13
2.6	Tensioning the blade.....	2-14
2.7	Tracking the blade	2-16
2.8	Starting The Engine (or Motor).....	2-18
2.9	Hydraulic Control Operation.....	2-19
2.10	Loading, Turning, And Clamping Logs	2-21
2.11	Up/Down Operation	2-24
2.12	Blade Guide Arm Operation.....	2-25
2.13	Power Feed Operation	2-26
2.14	Cutting The Log	2-28
2.15	Wireless Control Panel (option)	2-29
2.16	Edging.....	2-30
2.17	Optional Cutting Procedure	2-31
2.18	Blade Height Scale	2-31
2.19	Water Lube Operation	2-33
2.20	Preparing The Sawmill For Transportation.....	2-34

Table of Contents

Section-Page

SECTION 3	MAINTENANCE	3-1
3.1	Wear Life.....	3-1
3.2	Blade Guides	3-2
3.3	Sawdust Removal	3-5
3.4	Carriage Track, Wiper & Scrapers	3-5
3.5	Vertical Mast Rails	3-7
3.6	Drum Switches	3-7
3.7	Miscellaneous Maintenance	3-7
3.8	Drive Belt Adjustment.....	3-8
3.9	Up/Down System.....	3-9
3.10	Power Feed	3-11
3.11	Hydraulic System	3-11
3.12	Safety Devices Inspection	3-13
SECTION 4	TROUBLESHOOTING	4-1
4.1	Sawing Problems	4-1
4.2	Electrical Problems.....	4-3
4.3	Power Feed Problems	4-4
4.4	Hydraulic Problems	4-6
4.5	Engine/Motor Drive Pulleys Alignment.....	4-9
4.6	Power Feed Variable Speed Switch Test.....	4-9
4.7	Power Feed Preliminary Test	4-9
4.8	Power Feed Mechanical Test.....	4-9
4.9	Circuit Breaker Operation	4-10
SECTION 5	SAWMILL ALIGNMENT	5-1
5.1	Routine Alignment Procedure:	5-1
5.2	Horizontal Adjustment of Side Supports.....	5-14
5.3	Complete Alignment Procedure	5-16
SECTION 6	MOTOR BRAKE	6-1
6.1	Maintenance/repair	6-1
6.2	Maintenance	6-2

Wood-Mizer is committed to providing you with the latest technology, best quality and strongest customer service available on the market today. We continually evaluate our customers' needs to ensure we're meeting current wood-processing demands. Your comments and suggestions are welcome.

If You Need To Order Parts...

From Europe call our European Headquarters and Manufacturing Facility in Kolo, Poland at **+48-63-2626000**. From the continental U.S., call our toll-free Parts hotline at **1-800-448-7881**. Please have the vehicle identification number and your customer number ready when you call. Wood-Mizer will accept these methods of payment:

- Visa, Mastercard, or Select Purchase
- COD
- Prepayment
- Net 15 (with approved credit)

Be aware that shipping and handling charges may apply. Handling charges are based on size and quantity of order. In most cases, items will ship on the day they are ordered. Second Day and Next Day shipping are available at additional cost.

If You Need Service...

From Europe call our European Headquarters and Manufacturing Facility in Kolo, Poland at **+48-63-2626000**. From the continental U.S., call us toll-free at **1-800-525-8100**. Ask to speak with a Customer Service Representative. Please have your vehicle identification number and your customer number ready when you call. The Service Representative can help you with questions about alignment of your mill, blade sharpening, or cutting a particular species of wood. He also can schedule you for a service call.

Office Hours: All times are Eastern Standard Time. Please remember that Indiana does not go on Daylight Savings Time in the summer.

Country	Monday - Friday	Saturday	Sunday
U.S., Indiana	8 a.m. to 5 p.m.	8 a.m. to 4 p.m.	Closed
Poland	8 a.m. to 4:30 p.m.	8 a.m. to 1 p.m.	Closed



IMPORTANT! Read the entire Operator's Manual before operating the sawmill. Take notice of all safety warnings throughout this manual and those posted on the machine. Keep this manual with this machine at all times, regardless of ownership.

*Wood-Mizer® is a registered trademark of Wood-Mizer Products, Inc.

Sawmill and Customer Identification

Each Wood-Mizer sawmill has a 17-digit Vehicle Identification Number (VIN). See the figure below for VIN locations. See the chart for VIN description.

Company Identification Number 456=Wood-Mizer Indiana	Weight Class; A=Under 1300 kg B=1300 - 1800kg C=1800-2200 kg D=2200kg-3000kg	Product No.; 1=LT15, 2=LT20, 4=LT40 Series, 7=LT70 Series	Length of the Trailer; 20=20 Ft., 24=24', 35=35'	Number of axles on the trailer	Check Digit Add all the number and divide by 11	Year of Manufacture; G=2009, H=2010, J=2011, K=2012, L=2013, M=2014	State of Manufacture N=Indiana, P=Poland	Month of Manufacture A=January, B=February, C=March, etc...	Revision Level	Sequence Number Ranging from 000-999	End of 17-Digit VIN	Revision Level (Repeated)	Two-Digit Minor Revision Level
456	A	7	24	1	X	J	N	A	F9	017		F9	.01

V.I.N. DESCRIPTION



V.I.N. LOCATIONS

Each sawmill is also identified with a model number which includes the base model and the engine/motor configuration. See the figure for a description of the model number.

LT70
Basic Sawmill I.D.

E25
Engine/Motor
Configuration

MODEL NUMBER DESCRIPTION.

When you pick up your mill, you will receive a customer number. Both the VIN and your customer number expedite our service to you. Please write these numbers below so you have quick, easy access to them.

Customer No.	Model No.	V.I.N.	Revision

SECTION 1 SAFETY & GENERAL INFORMATION

1.1 Safety Symbols

The following symbols and signal words call your attention to instructions concerning your personal safety. Be sure to observe and follow these instructions.



The word **DANGER** indicates an imminently hazardous situation which, if not avoided, will result in death or serious injury.



WARNING suggests a potentially hazardous situation which, if not avoided, could result in death or serious injury.



CAUTION refers to potentially hazardous situations which, if not avoided, may result in minor or moderate injury to persons or equipment.



Warning stripes are placed on areas where a single decal would be insufficient. To avoid serious injury, keep out of the path of any equipment marked with warning stripes.

Read and observe all safety instructions before operating this equipment! Also read any additional manufacturer's manuals and observe any applicable safety instructions including dangers, warnings, and cautions.

Always be sure that all safety decals are clean and readable. Replace all damaged safety decals to prevent personal injury or damage to the equipment. Contact your local distributor, or call your Customer Service Representative to order more decals.

IMPORTANT! It is always the owner's responsibility to comply with all applicable federal, state and local laws, rules and regulations regarding the ownership, operation and towing of your Wood-Mizer sawmill. All Wood-Mizer mill owners are encouraged to become thoroughly familiar with these applicable laws and comply with them fully while using or towing the mill.

Always properly dispose of all sawing by-products, including sawdust and other debris, coolant, oil, fuel, oil filters and fuel filters.

Safety instructions are listed in this section by the following operations:

- Blade Handling
- Sawmill Setup
- Sawmill Operation

- Sawmill Maintenance

1.2 Blade Handling



DANGER! Always disengage the blade and shut off the sawmill engine before changing the blade. Failure to do so may result in serious injury.



WARNING! Always wear gloves and eye protection when handling bandsaw blades. Changing blades is safest when done by one person! Keep all other persons away from area when coiling, carrying or changing a blade. Failure to do so may result in serious injury.



WARNING! Do not spin the blade wheels by hand. Failure to do so may result in serious injury.

1.3 Sawmill Setup



WARNING! Chock the trailer wheels to prevent movement before unhitching it from the towing vehicle. Failure to do so will result in serious injury or death.

WARNING! Put front outrigger down before moving cutting head from the rest position. Failure to do so may result in serious injury.

WARNING! Securely fasten the feet of a stationary sawmill to the floor before operating the sawmill. Failure to do so will result in serious injury or death.

WARNING! Always make sure the trailer is supporting the sawmill frame when operating a sawmill with adjustable outriggers. Failure to do so will result in serious injury or death. The adjustable outriggers are intended to support the saw frame with assistance from the trailer.

WARNING! Do not set up the mill on ground with more than a 10 degree incline. If setup on an incline is necessary, put blocks under one side of the mill or dig out areas for outrigger legs to keep mill level. Setting up the mill on an incline could cause it to tip over, resulting in serious personal injury.



CAUTION! Changes in temperature could cause increased pressure in the blade tensioner and loss of fluid from the gauge. Release the blade tension when the mill is not in use to avoid damage to the tensioner.



CAUTION! Dismount hydraulic log turner leg before transportation in mobile sawmills.

1.4 Sawmill Operation



IMPORTANT! The sawmill is intended for sawing wood only. The sawmill must not be used for other purposes such as cutting ice, metal or any other materials. [See Section 1.9](#) for log size capacities of the machine.

IMPORTANT! The operator of the sawmill should get adequate training in the operation and adjustment of the machine.



DANGER! Make sure all guards and covers are in place and secured before operating or towing the sawmill. Failure to do so may result in serious injury.

Be sure the blade housing and pulley covers are closed.

DANGER! Always keep hands away from moving bandsaw blade. Failure to do so may result in serious injury.

DANGER! Stay clear of the area between the trailer axle and saw carriage. Failure to do so may result in serious injury.

DANGER! Keep all persons out of the path of moving equipment and logs when operating sawmill or loading and turning logs. Failure to do so may result in serious injury.

DANGER! Maintain a clean and clear path for all necessary movement around the mill and lumber stacking areas. Failure to do so may result in serious injury.

DANGER! Always be sure the blade is disengaged and all persons are away from the blade before starting the engine. Failure to do so may result in serious injury.

DANGER! Keep all persons out of the path of returning boards. Failure to do so may result in serious injury.



WARNING! Always disengage the clutch/brake mechanism whenever the sawmill is not cutting. Failure to do so may result in serious injury.

WARNING! Always wear eye, ear, respiration, and foot protection when operating the sawmill. Failure to do so may result in serious injury.

WARNING! Be sure the power feed switch is in the neutral position before turning the key switch to the on (#1) or accessory (#3) position. This prevents accidental carriage movement which may cause serious injury or death.



WARNING! Secure all loose clothing and jewelry before operating the sawmill. Failure to do so will result in serious injury or death.

WARNING! Always make sure log is clamped securely before sawing. Failure to do so will result in serious injury or death.

WARNING! Always leave loading arm halfway up while log is on sawmill bed. Failure to do so will result in serious injury or death.

WARNING! The automatic board return is intended to assist a second operator in removing boards quickly. Do not use the board return when operating the sawmill alone. Failure to do so will result in serious injury, death or damage to the equipment.

WARNING! Never use the board return table as a platform to stand on. This table is designed and intended to assist in the removal of boards only. Standing on the table may result in serious injury.

WARNING! Use ONLY water with the water lube accessory. Never use flammable fuels or liquids. If these types of liquids are necessary to clean the blade, remove it and clean with a rag. Failure to do so will result in serious injury or death.



CAUTION! Be sure the pivot rails, turning arm, clamp, and toe boards are below bed level before loading a log onto the bed. Failure to do so may result in machine damage or cause misalignment.

CAUTION! Before loading a log, be sure the cutting head is moved far enough forward so the log does not hit it. Damage to the sawmill may result.

CAUTION! Always make sure the engine is running before operating the hydraulic controls. Operating the controls without the engine running will result in power drainage from the battery. Holding the hydraulic switches halfway up or down also will cause excessive drainage from the battery.

CAUTION! Do not try to force the saw head beyond its upper and lower travel limits. Damage to the up/down system may result.

CAUTION! Always make sure the up/down switch moves to the neutral or off position when released to ensure that the saw head stops moving. Damage to the sawmill may result.

CAUTION! Move the hydraulic clamp and turner to provide maximum ground clearance before towing. Failure to do so may result in damage to the sawmill.

CAUTION! Be sure to stop the blade when returning the carriage. This will not only prevent the blade from being pulled off and ruined by a wood sliver, but also will increase the life of the blade.

CAUTION! The sawmill's work-stand should be equipped with a 4 kg or bigger dry powder extinguisher.

1.5 Sawmill Maintenance



WARNING! Always secure the cutting head with a chain or a brace before adjusting the up/down chain. The cutting head may fall, causing severe injury or death.

WARNING! Always secure the cutting head with a chain or a brace before removing the up/down motor belt. The cutting head may fall, causing severe injury or death.

WARNING! Drum switch grease contains Petroleum Hydrocarbon Lubricant. Eye and skin irritant. If introduced into eyes, flush with water for at least 15 minutes. If film or irritation persists, seek medical attention. Wash skin with soap and water. If ingested, do not induce vomiting - contact a physician. KEEP OUT OF THE REACH OF CHILDREN.

CAUTION! Reinstall the track wiper so that it lightly touches the track rail. If the wiper presses too firmly against the rail, it can cause the power feed to bind.

CAUTION! Never use grease on the mast rails as it will collect sawdust.

CAUTION! Do not use chain lube. It causes sawdust buildup in chain links.

CAUTION! Do not over-tension the up/down chain. Over-tensioning may lead to early failure of the gear reducer.

CAUTION! Do not overtighten the feed chain. Damage to the power feed motor may result.



CAUTION! Do not overtighten the contact set screws on the hydraulic valve assembly. Overtightening may cause the threads in the screw hole to strip.

CAUTION! It is important that the lower stop bolts are properly adjusted to secure the carriage on the track rail. Failure to properly adjust the stop bolts can cause saw head damage, especially during mill transportation.

CAUTION! Pressure should not exceed 2000 psi. If it does, the amp draw will rise above the design maximum of 200 amps, and could cause battery and system problems. Pressure above 2000 p.s.i. may also damage the hydraulic hoses.

CAUTION! Failure to remove sawdust buildup from the battery box lid and/or track rail cover could result in damage to these parts when the saw head is lowered to its lowest position.

1.6 Safety Instructions

NOTE: ONLY safety instructions regarding personal injury are listed in this section. Caution statements regarding only equipment damage appear where applicable throughout the manual.

Observe Safety Instructions



IMPORTANT! Read the entire Operator's Manual before operating the sawmill. Take notice of all safety warnings throughout this manual and those posted on the machine. Keep this manual with this machine at all times, regardless of ownership.

Also read any additional manufacturer's manuals and observe any applicable safety instructions including dangers, warnings, and cautions.

Only adult persons who have read and understood the entire operator's manual should operate the sawmill. The sawmill is not intended for use by or around children.

IMPORTANT! It is always the owner's responsibility to comply with all applicable federal, state and local laws, rules and regulations regarding the ownership and operation of your Wood-Mizer sawmill. All Wood-Mizer sawmill owners are encouraged to become thoroughly familiar with these applicable laws and comply with them fully while using the machine.



Wear Safety Clothing



WARNING! Secure all loose clothing and jewelry before operating the sawmill. Failure to do so may result in serious injury or death.

WARNING! Always wear gloves and eye protection when handling bandsaw blades. Changing blades is safest when done by one person! Keep all other persons away from area when coiling, carrying or changing a blade. Failure to do so may result in serious injury.

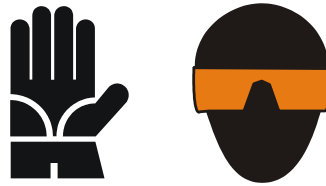

WARNING! Always wear eye, ear, respiration, and foot protection when operating or servicing the sawmill.



Keep sawmill And Area Around sawmill Clean



DANGER! Maintain a clean and clear path for all necessary movement around the sawmill and lumber stacking areas. Failure to do so will result in serious injury.

Dispose Of Sawing By-Products Properly



IMPORTANT! Always properly dispose of all sawing by-products, including sawdust and other debris.

Check sawmill Before Operation



DANGER! Make sure all guards and covers are in place and secured before operating the sawmill. Failure to do so may result in serious injury.



Keep Persons Away



DANGER! Keep all persons out of the path of moving equipment and lumber when operating the sawmill. Failure to do so will result in serious injury.

DANGER! Always be sure all persons are out of the path of the blade before starting the motor. Failure to do so will result in serious injury.



WARNING! Allow blade to come to a complete stop before opening the blade housing cover. Failure to do so will result in serious injury.

Keep Hands Away



DANGER! Always shut off the blade motor before changing the blade. Failure to do so will result in serious injury.

DANGER! Motor components can become very hot during operation. Avoid contact with any part of a hot motor. Contact with hot motor components can cause serious burns. Therefore, never touch or perform service functions on a hot motor. Allow the motor to cool sufficiently before beginning any service function.

DANGER! Always keep hands away from moving bandsaw blade. Failure to do so will result in serious injury.

DANGER! Always be aware of and take proper protective measures against rotating shafts, pulleys, fans, etc. Always stay a safe distance from rotating members and make sure that loose clothing or long hair does not engage rotating members resulting in possible injury.



WARNING! Use extreme caution when spinning the blade wheels by hand. Make sure hands are clear of blade and wheel spokes before spinning. Failure to do so may result in serious injury.

Use Proper Maintenance Procedures



DANGER! Make sure all electrical installation, service and/or maintenance work is performed by a qualified electrician and is in accordance with applicable electrical codes.

DANGER! Hazardous voltage inside the electric boxes and at the motor can cause shock, burns, or death. Disconnect and lock out power supply before servicing! Keep all electrical component covers closed and securely fastened during sawmill operation.



WARNING! Consider all electrical circuits energized and dangerous.

WARNING! Disconnect and lock out power supply before servicing the sawmill! Failure to do so may result in serious injury.

WARNING! Never assume or take the word of another person that the power is off; check it out and lock it out.

WARNING! Do not wear rings, watches, or other jewelry while working around an open electrical circuit.

WARNING! Remove the blade before performing any service to the motor or sawmill. Failure to do so may result in serious injury.

DANGER! Never clean the blade or blade wheels using the hand-held brush or scraper whilst the sawmill blade is in motion.

CAUTION! Before installation of the blade, inspect it for damage and cracks. Use only properly sharpened blades. Always handle the blade with extreme caution. Use suitable carrier equipment for transporting the blades.

CAUTION! Always wear gloves when handling the blade. Never grab the blade with bare hands!

CAUTION! If the blade breaks during sawmill operation, push the EMERGENCY STOP button to stop the blade motor and wait 10 seconds before you open the blade housing cover.

CAUTION! The sawmill's work-stand should be equipped with a 4 kg or bigger dry powder extinguisher.

Keep Safety Labels In Good Condition



IMPORTANT! Always be sure that all safety decals are clean and readable. Replace all damaged safety decals to prevent personal injury or damage to the equipment. Contact your local distributor, or call your Customer Service Representative to order more decals.

IMPORTANT! If replacing a component which has a safety decal affixed to it, make sure the new component also has the safety decal affixed.

1.7 Belt Sizes

See Table 1-1. Belt sizes for the LT70AC are shown.

Description	Belt Size	Wood-Mizer Part #
Motor Drive Belt (E25)	3B/HB 2462La	089464
Up/Down Drive Belt (AC mills)	HA-670	091328
Blade Pulley Belts	B72.5 ¹	017922

TABLE - 0-0

¹ To insure proper blade tracking, use Goodyear, Dayco Super II, or Browning belts only.

See Table 1-2. Pictogram decals used to warn and inform the user about danger in the LT70.

TABELA 1-2



Decal View	W-M No.	Description
	096317	CAUTION! Read thoroughly the manual before operating the machine. Observe all safety instructions and rules when operating the sawmill.
	099220	CAUTION! Close all guards and covers before starting the machine.

TABELA 1-2

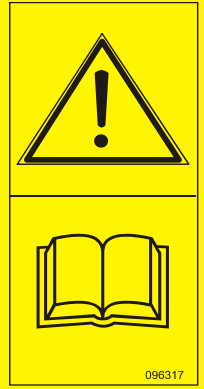

	099221	CAUTION! Keep all persons a safe distance away from work area when operating the machine.
	098176	CAUTION! Keep away from debarker blade!
	096316	CAUTION! Do not open or close the electric box when the switch is not in the "0" position.

TABELA 1-2

	<p>096317</p>	<p>CAUTION! Disconnect power supply before opening the box.</p>
	<p>085977B</p>	<p>No lift the machine grasping by the element!</p>
	<p>086099</p>	<p>CAUTION! Keep away - hot parts!</p>
	<p>099222</p>	<p>CAUTION! Sawdust outlet. Protect eyes!</p>

TABELA 1-2

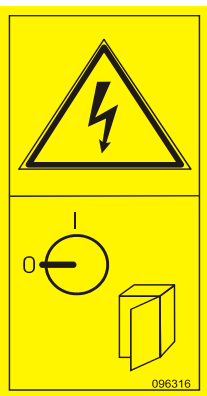

	099542	CAUTION! Trailer.
	096321	Blade movement direction
	505189	Lever of tensioner's ball valve
	S12004G	CAUTION! Always wear safety goggles when operating the sawmill!
	S12005G	CAUTION! Always wear protective ear muffs when operating the sawmill!

TABELA 1-2



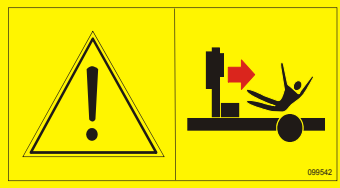
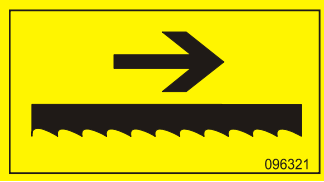
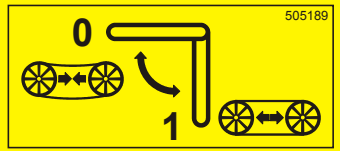

	<p>501465</p>	<p>CAUTION! Always wear safety boots when operating the sawmill</p>
	<p>501467</p>	<p>Lubrication Point</p>
 <p>P11789-70</p>	<p>P11789-70</p>	<p>Aligning the blade on the wheels</p>
	<p>P85070</p>	<p>CE safety certification</p>
	<p>099401</p>	<p>Russian safety certification</p>

TABELA 1-2

	S20097	2930 RPM - Motor rotation direction
---	--------	-------------------------------------

1.8 Blade Sizes

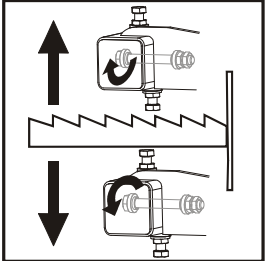
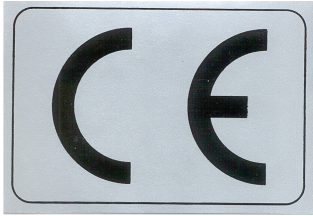
See Table 1-3. Wood-Mizer TRU•SHARP™ offers three types of blades to provide efficient sawing for all models of sawmills. The engine/motor size of your sawmill and the type of wood you saw should determine which blade you choose for optimum performance. ¹

	Softwood	Medium Hardwood	Frozen Timber or Dense Hardwood
15-18.5kW (20-25HP) Electric Diesel 42 KM	B376IH1030 B376IH741030	B275IH1030 B275IH741030 B376IH1030 B376IH741030 ²	B375IH929 ¹

TABLE - 0-0

¹ TRU•SHARP™ “F” blades use a 9/29 profile (9° hook angle and 29° back angle) and are designed to cut frozen and/or extremely dense, hard-to-cut wood. Standard TRU•SHARP™ blades use a 10/30 profile.

See *The Blade Handbook* for blade hook angle, tooth height, and tooth set specifications.

1.9 Cutting Capacity

See Table 1-4. The LT70 Super sawmills can accept logs as listed below.

	LT70 Super
Maximum Log Diameter	36,6” (93 cm)
Max. Length ¹	20’-2” (6.1 m)

TABELA. 1-4

¹.LT70 Sawmill is equipped with a blade with a length of 4.67 m.

Maximum Log Weight ²	4400 lbs. (1996 kg)
--	---------------------

TABELA. 1-4

- ¹ If your sawmill is equipped with a bed extension option, add the length of this extension to the sawmill length capacity (e.g. for BX12 add 12').
- ² Sawmills equipped with bed extensions can accept heavier logs. A load must be distributed uniformly on the frame and bed extension. Maximal weight for BX6 extension is 500kg, for BX12 – 1000kg, for BX24 – 2000kg. Failure to do so may result in machine damage or serious injuries.

1.10 Engine/Motor Specifications

See Table 1-5. Engine/motor type specifications for the LT70 are shown below.

Engine/Motor Type ¹	Manufacturer	Model Number	Power	Other Specifications
Electric Motor 25KM ²	Indukta SA, Poland	Sg 160L-2	18,5kW	33.8 A, 2930 RPM

TABLE - 0-0

¹ Use diesel fuel for D42.

² The electric motors supplied on Wood-Mizer sawmills carry a rating assigned by the motor manufacturer for the continuous duty operation of the motor, potentially, 24 hours per day, day after day. This rating is useful in sizing motors for use in applications like blowers for heating and ventilation that are never cycled off except for system maintenance.

See Table 1-6. The other motors used in sawmills LT70AH are listed below.

Model	Manufacturer	Voltage	Rated output	WM Part No
Power Feed Motor	Besel, Polska	3x230/ 400V	1380 RPM - 1,1kW	090104
Up/Down Motor	Leeson, USA	3x230/ 400V	1390 RPM -1,1kW	086530
Blade Guide Arm Motor	Motor Products Owosso, USA	12V	60 RPM - 17W	P09698-1
Hydraulic Pump Motor	Besel, Polska	3x400V	1415 RPM - 4 kW	092258

TABLE 1-6

See Table 1-7. See the table below for power supply specifications for the LT70 sawmill

	3-Phase Volts	Fused Disconnect Switch	Recommended Wire Size
15kW (EA20)	400 VAC	32 A	6 mm ² up to 15 m of length
18,5kW (EA25)	400 VAC	40 A	6 mm ² up to 15 m of length
Hydraulic (+4kW)	400 VAC	+10A	+1,5 mm ² up to 15 m of length

TABELA 1-0



DANGER! It is recommended that a 30mA Ground Fault Interrupter (GFI) be used.

1.11 Noise Level

See Table 1-8. The average noise level is given in the table below¹².

Sawmill	Noise Level L _{EX8}
LT70 E15 AH	83,0 dB (A)
LT70 E20 AH	83,0 dB (A)
LT70 D42 DH	87,4 dB (A)

TABELA 1-8

1.12 Overall Dimensions

See Table 1-9. The overall dimensions of the LT70 sawmills with M frame are listed below.

Sawmill Model	Length ¹	Width ²	Width (Operating Position with Loading Arms)	Height ³	Weight	Weight w/Trailer

TABLE - 0-0

1. The noise level measurement was taken in accordance with PN-EN ISO 3746 Standard. The noise exposure level given above concerns an 8-hour work day. Value for associated uncertainty K=4dB.

2. The measured values refer to emission levels, not necessarily to noise levels in the workplace. Although there is a relation between emission levels and exposure levels, it is not possible to determine with certainty if preventives are needed or are not needed. The factors affecting a current level of noise exposure during work are inter alia room characteristics and characteristics of other noise sources, e.g. number of machines and machining operations nearby. Also, the permissible exposure level value may vary depending on country. This information enables the machine's user to better identify hazards and a risk.

LT70M Super	26' 2" (8 m)	6' 6" (2 m)	8' 2" (2.5 m)	7' 8" (2.4 m)	3491 lbs. (1571 kg)	3916 lbs. (1762 kg)
--------------------	-----------------	----------------	------------------	------------------	------------------------	------------------------

TABLE - 0-0

¹ Length from hitch to chain bracket.

² Width from fender to fender.

³ Height from ground to mast. Placing head in maximum position will add to total height.

1.13 Chains

See Table 1-10. The load capacity of the chains is listed below.

Load Capacity According to ISO Nr 08A-1	
Power Feed Chain	22700 N
Up/Down Chain	45400 N

TABLE - 0-0

1.14 Hydraulic system

See Table 1-11. The specifications of the hydraulic system are shown below.

Hydraulic Pump	#M-300-0230 Monarch
Pressure Rating	15MPa (2200 PSI)
Max. Pressure	16MPa (2300 PSI)

TABLE - 0-0

1.15 Dust Extractor Specifications

See Table 1-12. Specifications of the dust extractors used on the resaw for each saw head are listed below.¹

Airflow	1200 m ³ /h 3937ft ³ /h
Inlet diameter	100 mm (5.9")
Motor power	1,5 kW
Number of sacks	1 pcs
Sack capacity	0,25 m ³ (8.8 ft) ³
Weight	110 kg (242.5 lb)
Pressure drop	1,5 kPa (0.22 psi) ¹
Recommended conveying air velocity in the duct	20 m/s 65.6 ft/s

TABLE 1-12

¹ The pressure drop between the inlet of the capture device and the connection to the CADES should be maximum 1,5 kPa (for the nominal air flow rate). If the pressure drop exceeds 1,5 kPa the machine might not be compatible with conventional CADES.



IMPORTANT! The dust extractor hoses must be grounded or made with materials not accumulating electrostatic charge.



CAUTION! Always turn on the dust extractor before starting the machine



IMPORTANT! The total value of hand-arm vibration the operator may be exposed to does not exceed 2.5 m/s². The highest root mean square value of weighted acceleration to which the whole operator's body is subjected does not exceed 0.5 m/s².

1.16 Components

1. External chip and dust extraction equipment with fixed installations are dealt with in EN 12779:2004+A1:2009

See Figure 1-1. The major components of the Wood-Mizer LT70 are shown below.

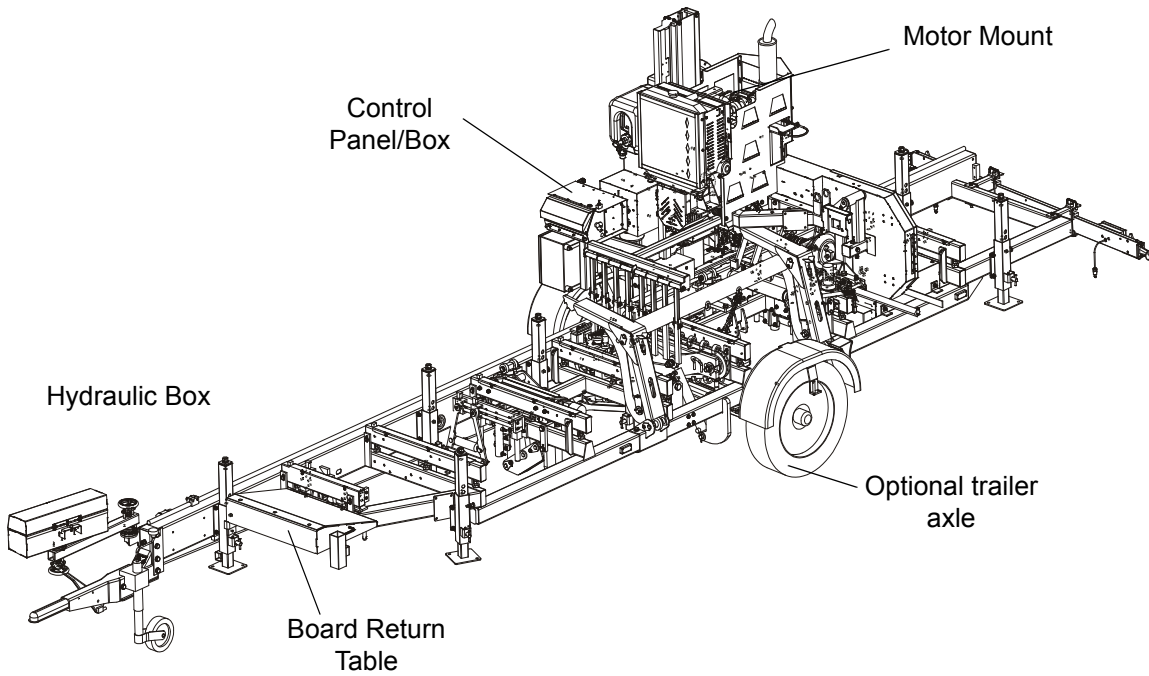

FIG. 1-1

1.17 LT40/70 S/M AH Hydraulic Schematic

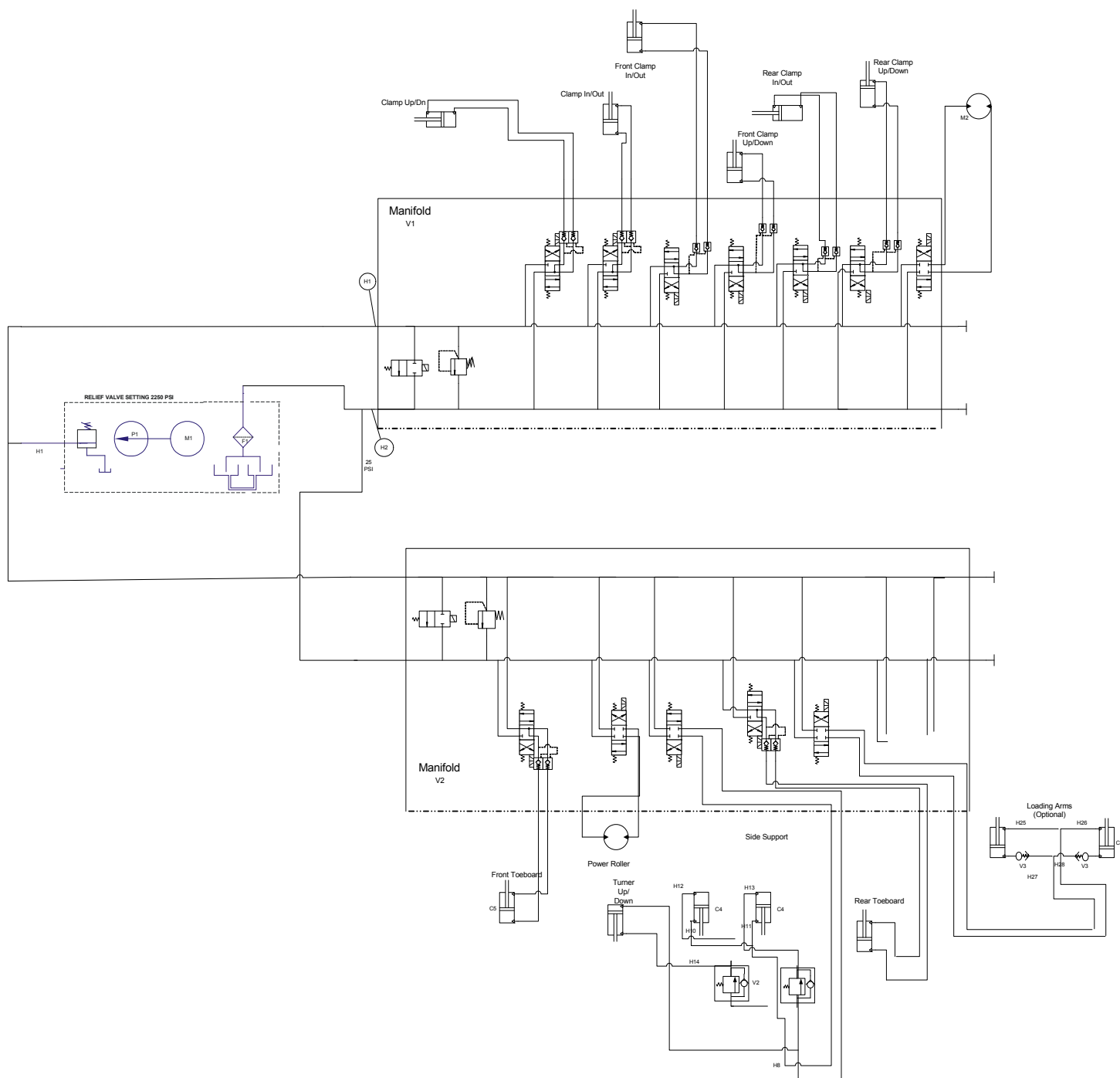

FIG. 1-2 HYDRAULIC SCHEMATIC.

1.18 LT40/70 S/M AH Hydraulic Components

ID	Mfg. Part No.	Manufacturer	Wood-Mizer Part #	Description
C1	015090	J-D Hydraulic	017275	Hyd. Cylinder, 3" Bore x 7 7/8" Stroke
C2	PMC-19410	Prince Mfg.	015053	Hyd. Cylinder, 1 1/2" Bore x 10" Stroke
C3	P12846	J-D Hydraulic	P12846	Hyd. Cylinder, 2 1/2" Bore x 8" Stroke
C4	P12845	J-D Hydraulic	P12845	Hyd. Cylinder, 2" Bore X 6" Stroke
C5, C6	014482	J-D Hydraulic	014482	Hyd. Cylinder, 1 1/2" Bore x 6" Stroke
C7, C8	P12847	J-D Hydraulic	P12847	Hyd. Cylinder, 3" Bore X 8" Stroke
M1, P1	---	Hydromar, Szamotuly	086789	Hydraulic Unit (Container + Hydraulic Pump + Motor), 14.5 l/min.
V1	HDS11/6-6	Betro Inc.	015260	Valve, 6-Handle
V2, V3	49004-700	Vonberg	015484	Sequence Valve
V4, V5	28000-502-2.5	Vonberg	015750	Valve, Hydraulic Velocity Fuse
F1	S28	Hyd. Filter Supply	P20301	Filter, Hydraulic Fluid Cartridge

TABLE - 0-1



Safety & General Information

LT40/70 S/M Hydraulic Hoses

1.19 LT40/70 S/M Hydraulic Hoses

ID	Color Code	Length "A"	Application	Wood-Mizer Part No.
H1	None	18"	1/4" hydraulic pump to valve	015704
H2	None	18"	1/4" hydraulic pump to valve	015704
H3	Plain	27"	3/8" log turner cylinder base	014796
H4	Orange	0.69m (27")	3/8" Log Turner Cylinder Top	087775
H5	Yellow	3.27m (129")	1/4" Front Toe Board Top (LT40S)	087790
		3.83m (151")	1/4" Front Toe Board Top (LT40M)	087776
H6	Gray	3.27m (129")	1/4" Front Toe Board Base (LT40S)	087790
		3.83m (151")	1/4" Front Toe Board Base (LT40M)	087776
H7	Pink	4.2m (166")	3/8" Side Support Cylinder Base (LT40S)	087791
		4.77m (188")	3/8" Side Support Cylinder Base (LT40M)	087777
H8	Plain	4.2m (166")	3/8" Side Support Cylinder Top (LT40S)	087791
		4.77m (188")	3/8" Side Support Cylinder Top (LT40M)	087777
H9	White	3.68m (145")	3/8" Clamp Cylinder Top (LT40S)	087792
		4m (157")	3/8" Clamp Cylinder Top (LT40M)	087778
H10	Dark Orange	3.28m (129")	3/8" Clamp Cylinder Base (LT40S)	087793
		3.8m (151")	3/8" Clamp Cylinder Base (LT40M)	087779
H11	Purple	5.2m (204")	1/4" Rear Toe Board Top (LT40S)	087794
		5.74m (226")	1/4" Rear Toe Board Top (LT40M)	087780
H12	Black	5.2m (204")	1/4" Rear Toe Board Base (LT40S)	087794
		5.74m (226")	1/4" Rear Toe Board Base (LT40M)	087780
H13	Green	1.58m (62")	3/8" Loading Arm Branch Top	014797

TABELA. 1-13

H14	Yellow	1.6m (63")	3/8" Loading Arm Branch Base	014798
H14	Yellow	1.8m (71")	3/8" Loading Arm Branch Base	093329
H15	Blue	4.34m (171")	3/8" Loading Arm Cylinder Top (LT40S)	087795
		4.9m (193")	3/8" Loading Arm Cylinder Top (LT40M)	087781
H16	Red	4.34m (171")	3/8" Loading Arm Cylinder Bottom (LT40S)	087795
		4.9m (193")	3/8" Loading Arm Cylinder Bottom (LT40M)	087781
H17	Green	4.57m (180")	1/4" Clamp Up (LT40S)	087796
		5.1m (202")	1/4" Clamp Up (LT40M)	087789
H18	Yellow	4.57m (180")	1/4" Clamp Down (LT40S)	087796
		5.1m (202")	1/4" Clamp Down (LT40M)	087789

TABELA. 1-13

1.20 Hydraulic Blade Tensioner Assembly

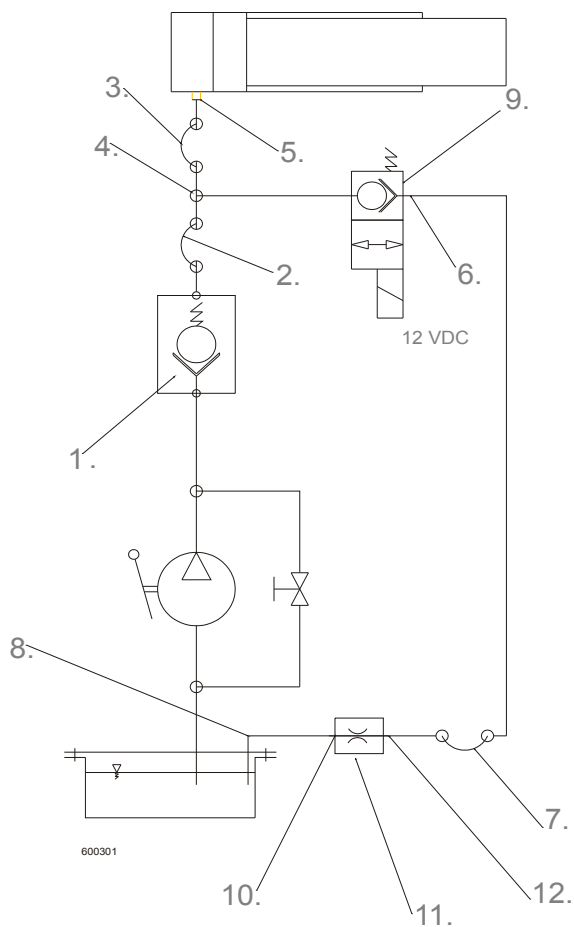

FIG. 1-3 HYDRAULIC SCHEMATIC.

SECTION 2 SETUP & OPERATION

2.1 Sawmill Setup



IMPORTANT! Before starting to use the sawmill you have to meet the following conditions:

- Set up the sawmill on firm, level ground and level the sawmill. Secure the sawmill to the ground to prevent moving during operation. A concrete foundation or pads (rated to support 31 T/m² at each sawmill foot position) and 16 mm anchored bolts are recommended.
- Under roof, the sawmill can be operated with the sawdust collection system only.
- The sawmill can't be operated outdoor when it is raining/snowing and in case of rain/snow the sawmill must be stored under roof or indoor.
- The sawmill can be operated in temperature range from -15° C to 40° C only (AC sawmills).
- The illumination at the operator's position should be at least 300lx.
- The sawmill operator's position is shown below.

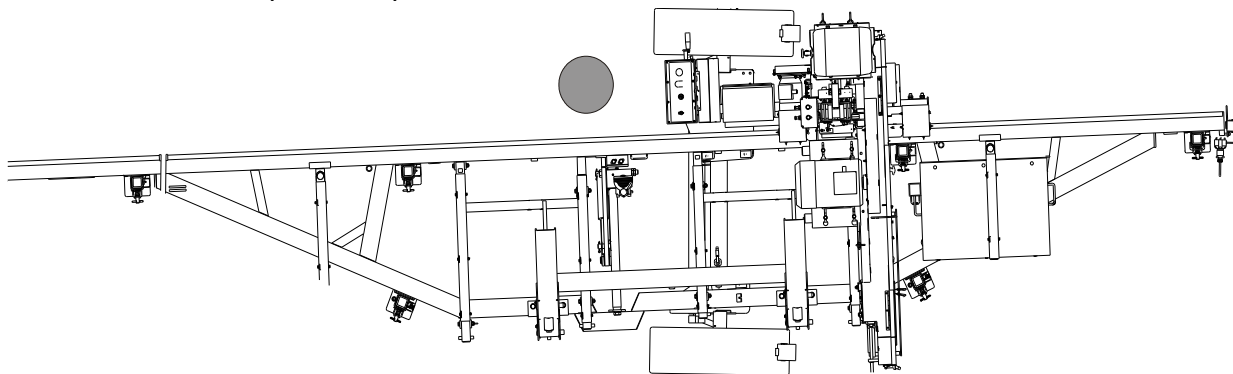

LT70M

- Have a qualified electrician install the power supply (according to EN 60204 Standard). The power supply must meet the specifications given in the table below.

3-Phase Volts	Fuse disconnect	Suggested Wire Size
400 VAC	40 A	6 mm ² up to 15 m long

TABLE 2-0



IMPORTANT! When starting the machine for the first time, check that main motor rotation direction is as indicated by the arrow located on the motor body (fan guard). If the rotation direction is incorrect, invert the phases in the phase inverter in the power socket (electric box). Setting the phases in the phase inverter correctly will ensure correct rotation directions of all sawmill motors.

- Have a qualified electrician install the power supply (according to EN 60204 Standard). The power supply must meet the specifications given in the table below.

3-Phase Volts	Fuse disconnect	Suggested Wire Size
400 VAC	40 A	6 mm ² up to 15 m long

TABLE 2-0



IMPORTANT! When starting the machine for the first time, check that main motor rotation direction is as indicated by the arrow located on the motor body (fan guard). If the rotation direction is incorrect, invert the phases in the phase inverter in the power socket (electric box). Setting the phases in the phase inverter correctly will ensure correct rotation directions of all sawmill motors.



CAUTION! Press the emergency button located on the control box to stop the blade and the track feed motor. Turn the emergency stop clockwise to release the stop. The sawmill not restart until the emergency stop is not released.



WARNING! In case of a blade or drive belt brake, wait until all rotating parts are completely stop. Failure to do so may result in serious injury

- Tie the belts in the places shown on the picture below. The sawmill can be lifted using a forklift, a winch or a crane. The belts and the lifting equipment must be rated for at least 3000kg (6600 lb).



WARNING! When lifting the sawmill, use extreme caution and keep all per-

sons at a safe distance. Failure to do so may result in serious injury or death.

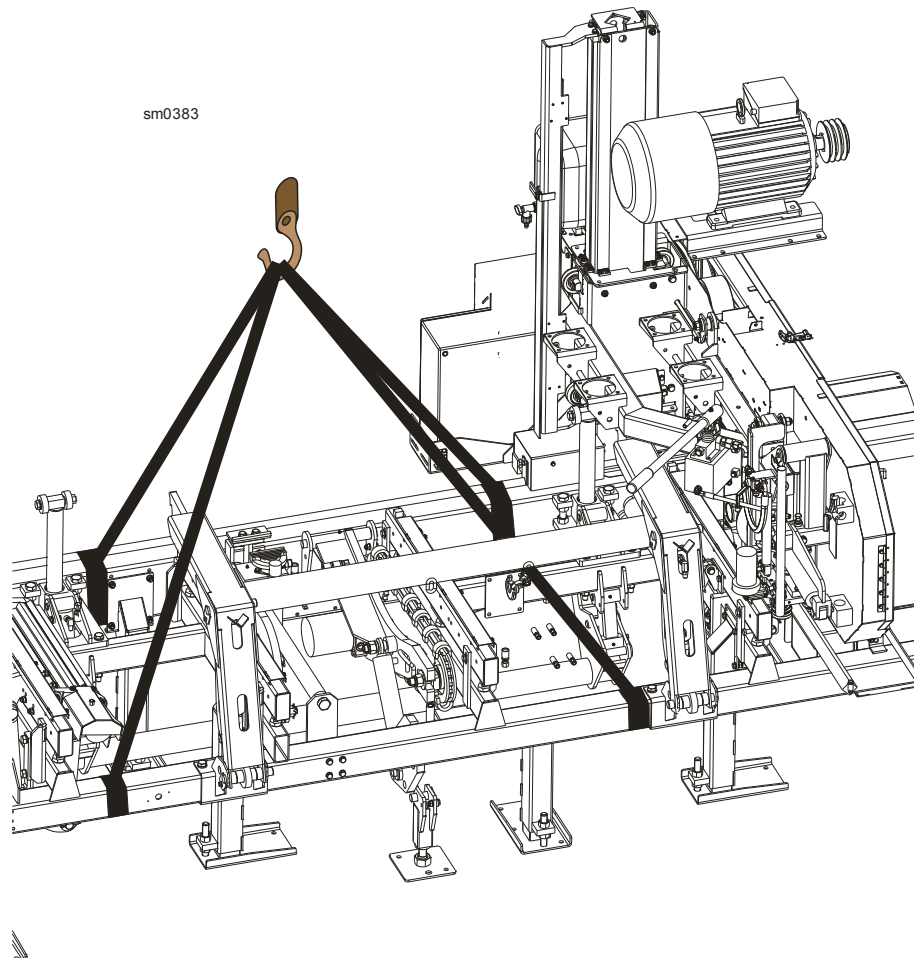

2.2 Stationary Sawmill Setup

Set up the mill on firm footing and level by eye. Fasten the mill to the floor to prevent any creep after prolonged use. Overall Dimensions- See Tabela 1-8 na stronie 14.

1. Unlock the hydraulic control box by pulling out the locking pin from the control box lock bracket. Remove the control box lock bracket from the saw head track rails.
2. Unhook the carriage safety chain, located at the bottom of the vertical mast.
3. Turn the key switch on the control panel to the accessory position. Use the up/down switch on the control panel to raise the cutting head from the carriage rest pin. Remove the locking pin and swing the rest pin down below bed level.
4. Use the carriage fwd/rev switch (left side of control box) to move the cutting head toward the front end of the mill. The hydraulic control levers become operational when the contacts at the bottom of the carriage touch



the power strip on the frame tube. The hydraulic control levers will only work when the cutting head is close enough to the front end of the mill to touch the power strip.

5. Raise the side supports that will prevent a log from falling off the side of the mill when loaded.

See Figure 2-1.

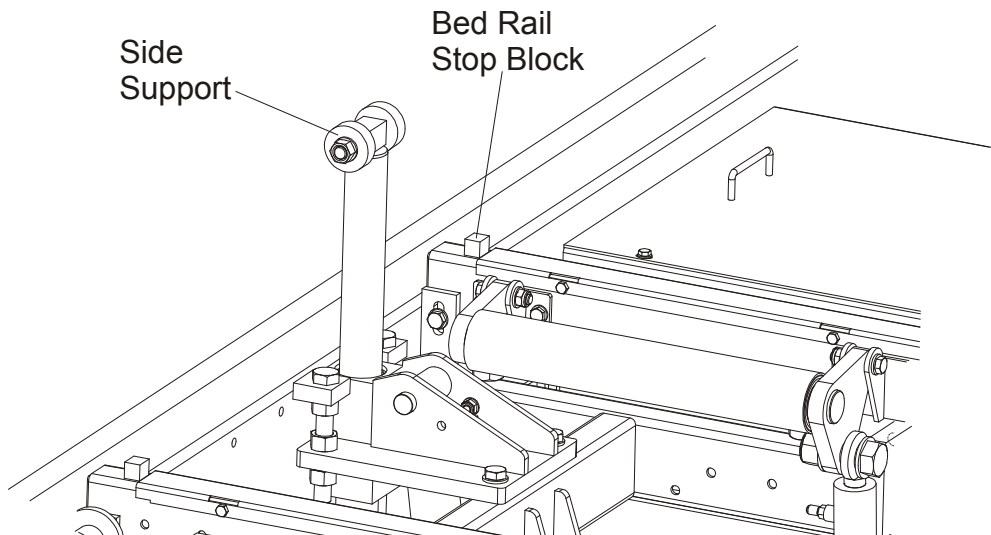

FIG. 2-0

2.2.1 *Sawmills with cable guide (optional equipment)*

See Figure 2-2. The figure below shows operator's position of the LT70MAH Super with cable guide.

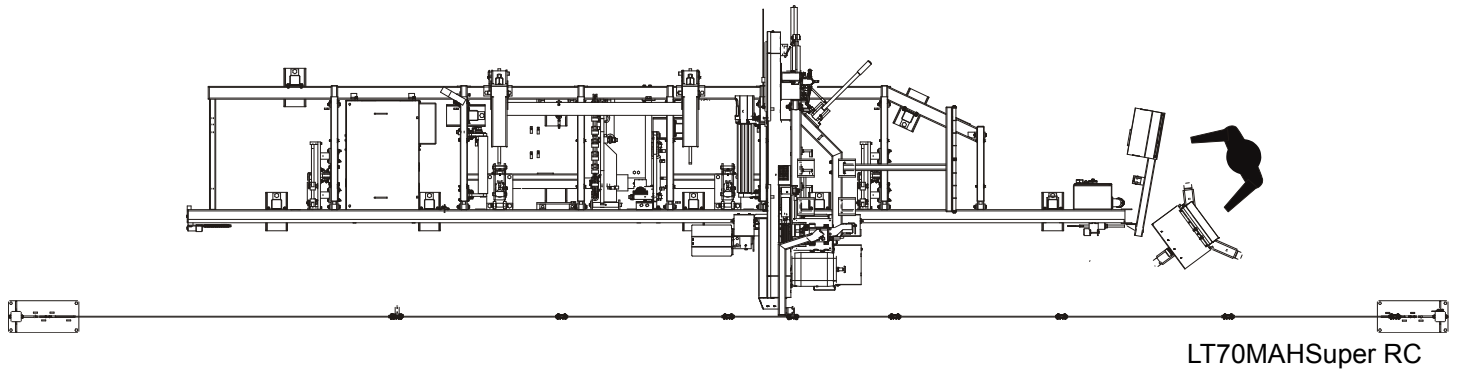

FIG. 2-1

See Figure 2-2. The figure below shows setup of the sawmill, the control box and the cable guide columns.

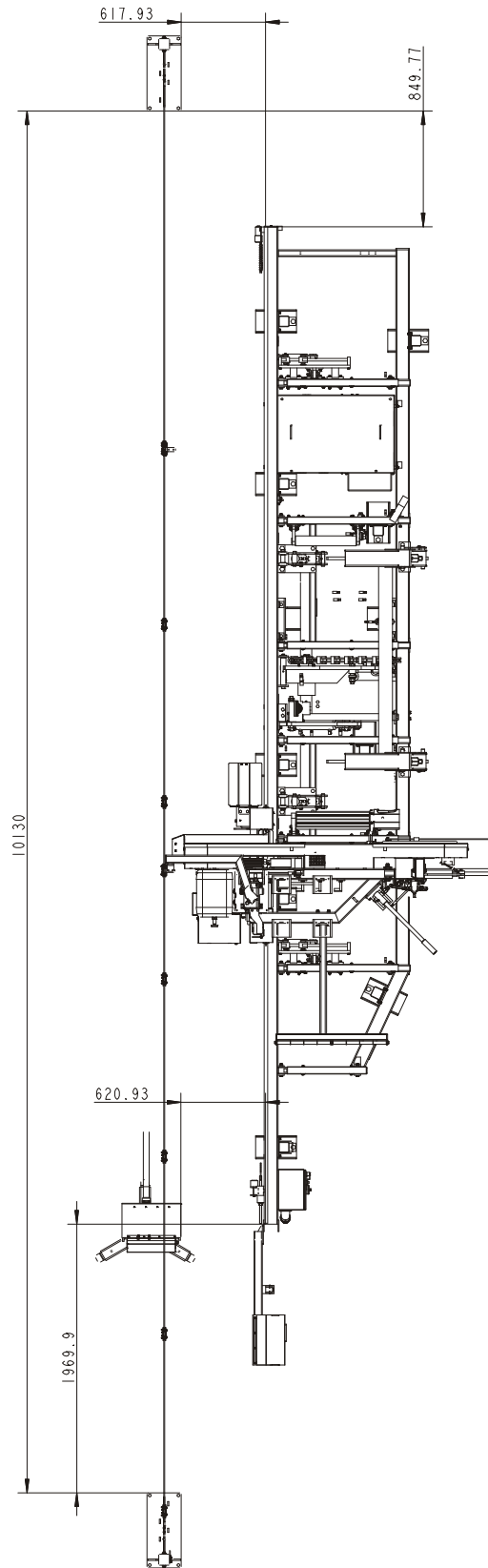

FIG. 2-2 LT70MSUPER RC

See Figure 2-3. The electrical wires should be installed on the cable guide as shown below.

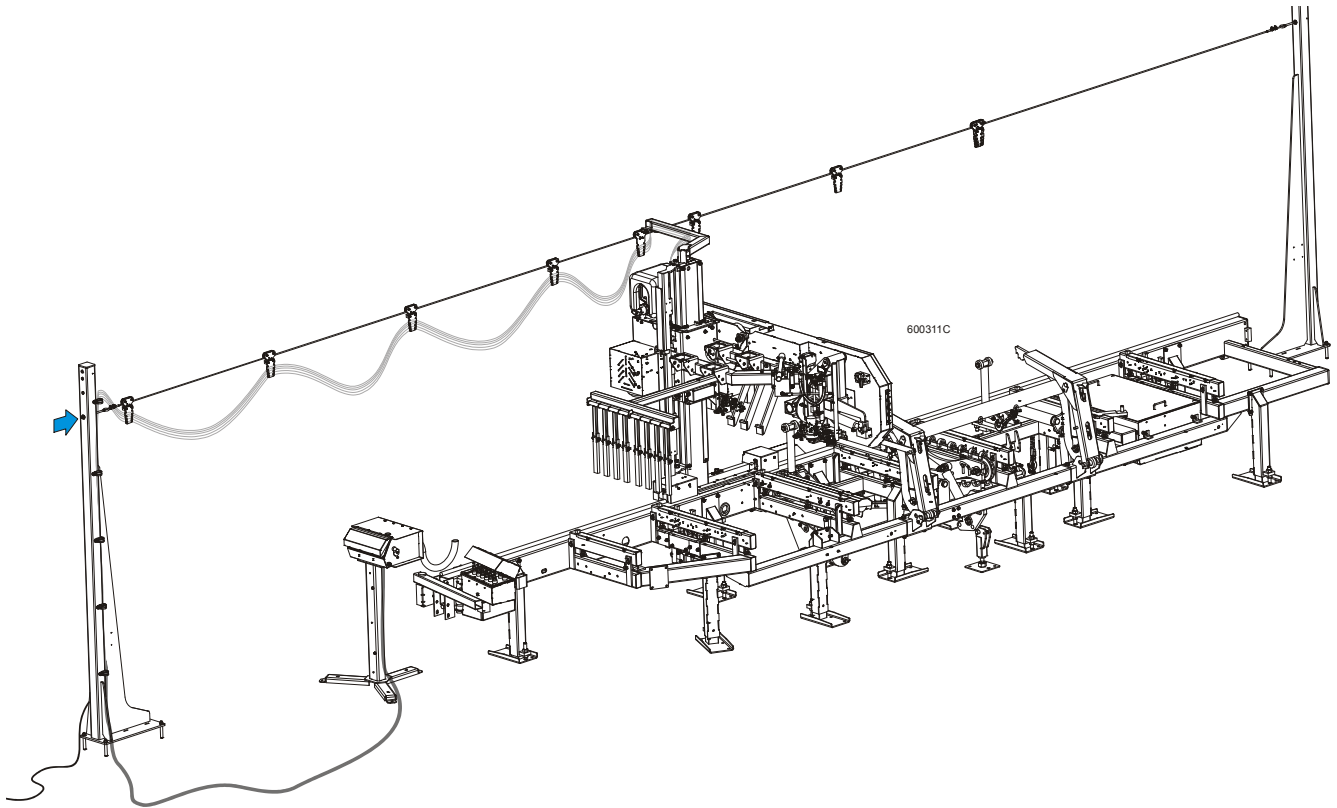

FIG. 2-3

See Figure 2-4. The figure below shows how the electrical wires should be installed on the roller hangers.

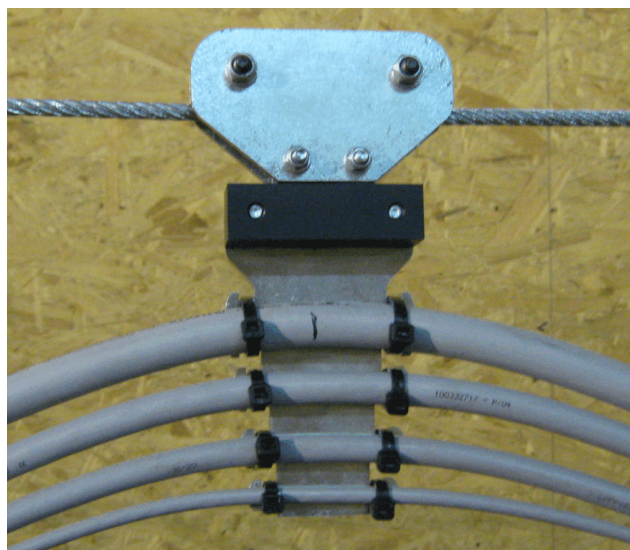

FIG. 2-4



CAUTION! Be sure the larger diameter cables are mounted to the upper brackets of the roller hangers, and the smaller diameter cables are mounted to the lower brackets of the hangers.

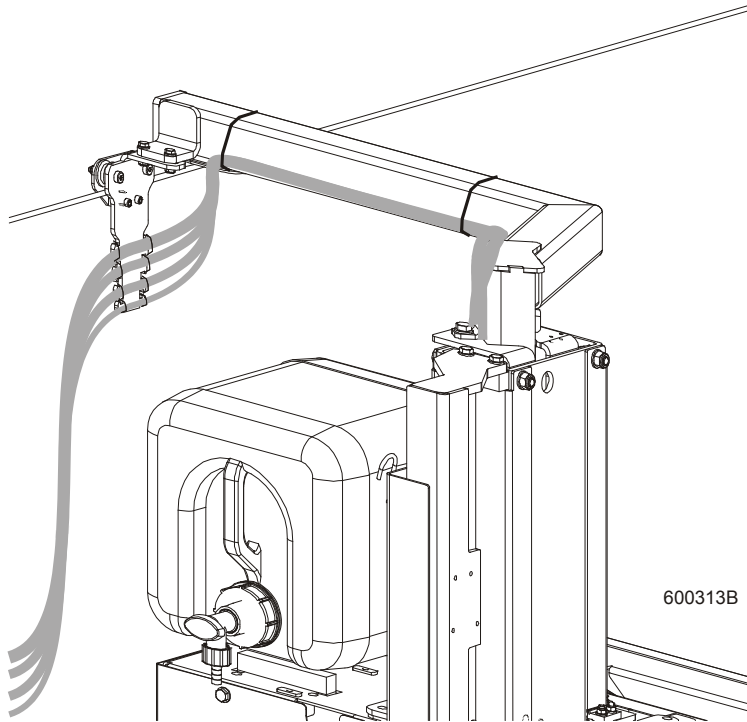

FIG. 2-4

2.3 Portable Sawmill Setup



WARNING! Do not set up the mill on ground with more than a 10 degree incline. If setup on an incline is necessary, put blocks under one side of the mill or dig out areas for outrigger legs to keep mill level. Setting up the mill on an incline could cause it to tip over, resulting in serious personal injury.

WARNING! Chock the trailer wheels to prevent movement before unhitching it from the towing vehicle. Failure to do so will result in serious injury or death.

WARNING! Always make sure the trailer is supporting the sawmill frame when operating a sawmill with adjustable outriggers. Failure to do so will result in serious injury or death. The adjustable outriggers are intended to support the saw frame with assistance from the trailer.

1. Unhitch the mill from the vehicle.
2. Lower and set the front outriggers. To lower the leg, first place a 19 socket wrench on the outrigger adjustment bolt and turn the bolt until the outrigger movable part reaches its highest position. Next pull the locking pin out of the outrigger hole. When the outrigger contacts the ground, release the pin. Then place a 19 socket wrench on the outrigger adjustment bolt and turn the bolt until the locking pin enters the nearest outrigger hole.



WARNING! Put front outrigger down before moving cutting head from the rest position. Failure to do so may result in serious injury.

2 Setup & Operation

Portable Sawmill Setup

See Figure 2-3.

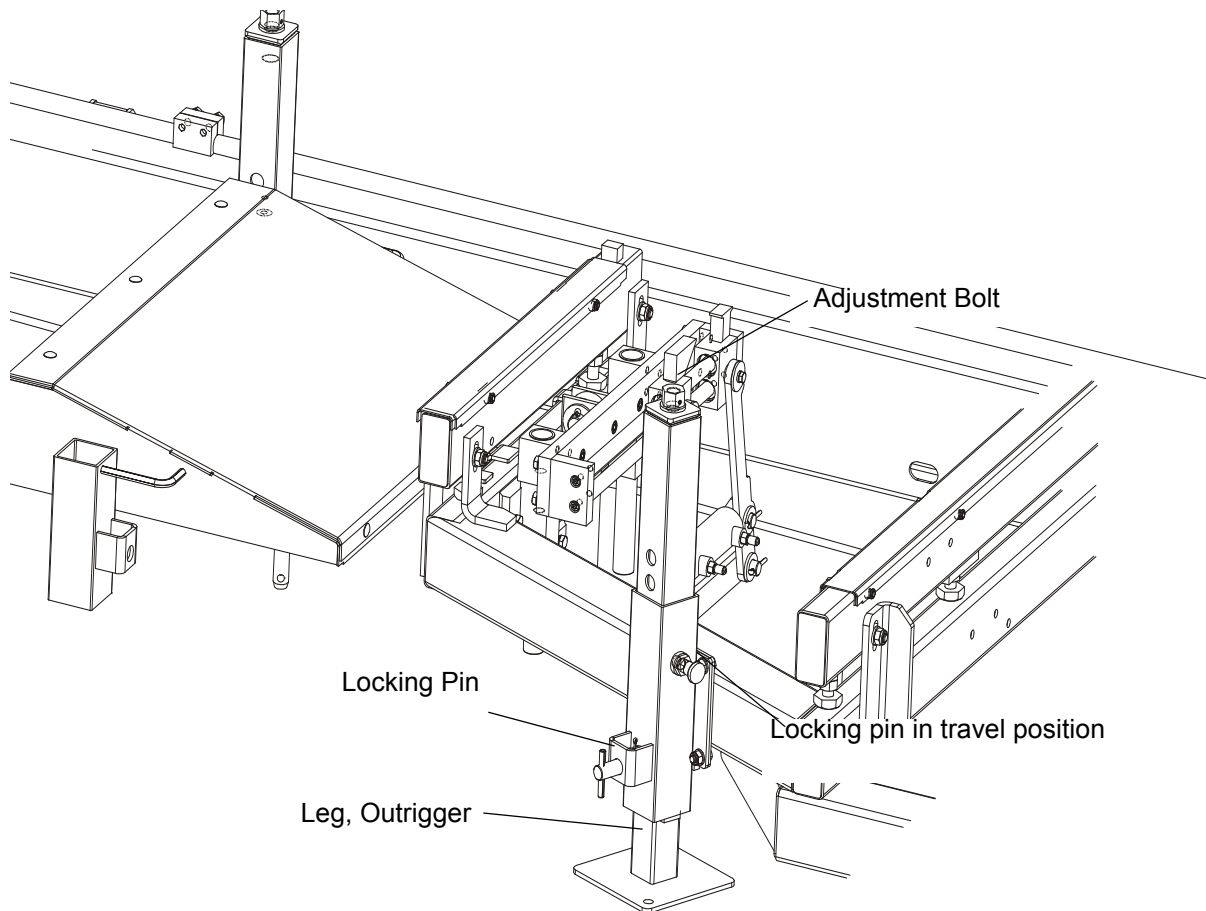

FIG. 2-4. OUTRIGGER ADJUSTMENT



CAUTION! If setup sawmill on a boggy terrain (such as deep mud or sand) place the board or metal plate under each outrigger leg to prevent it from sinking.

3. Unhook the carriage safety chain, located at the bottom of the vertical mast.



4. Turn the key switch on the control panel to the accessory (#3)(#1) position to enable the battery-operated accessories. Use the up/down switch on the control panel to raise the cutting head from the carriage rest pin. Remove the locking pin and swing the rest pin down below bed. Remove the fenders by lifting them out of the slots.



CAUTION! To prevent fender damage, remove fenders before operating sawmill or loading logs.

5. Use the carriage fwd/rev switch (left side of control box) to move the cutting head toward the front end of the mill. Lower and set the remaining rear outriggers.



6. Level the sawmill by adjusting the outriggers to raise or lower each end of the sawmill. Adjust all outriggers evenly to avoid twisting the mill frame by jacking one outrigger higher than the others.

Raise the side supports to prevent the log from falling off the side of the mill when loaded.

See Figure 2-4.

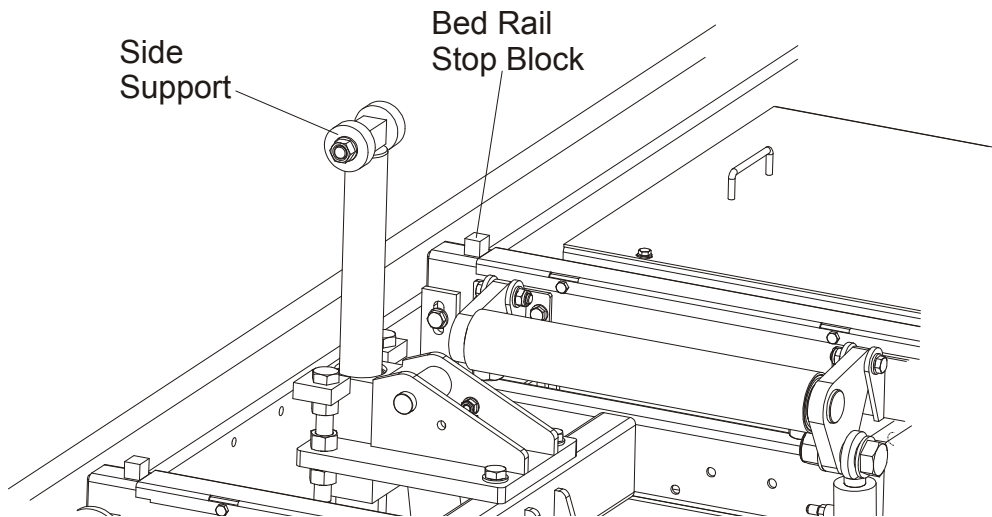

FIG. 2-4

2.4 Middle track cover

Before operating the sawmill do as follows:

1. Clean the upper and lower rails to remove any sawdust and rust preventives.
2. Unbolt and remove the middle track cover from its storage position.
3. Soak the felt wiper with Dexron III transmission fluid, 10W30 motor oil or 3-in-1 turbine oil.
4. Install the middle track cover so it fits against the rail and secure with two thumb screws.

2 Setup & Operation

Middle track cover

See Figure 2-5.

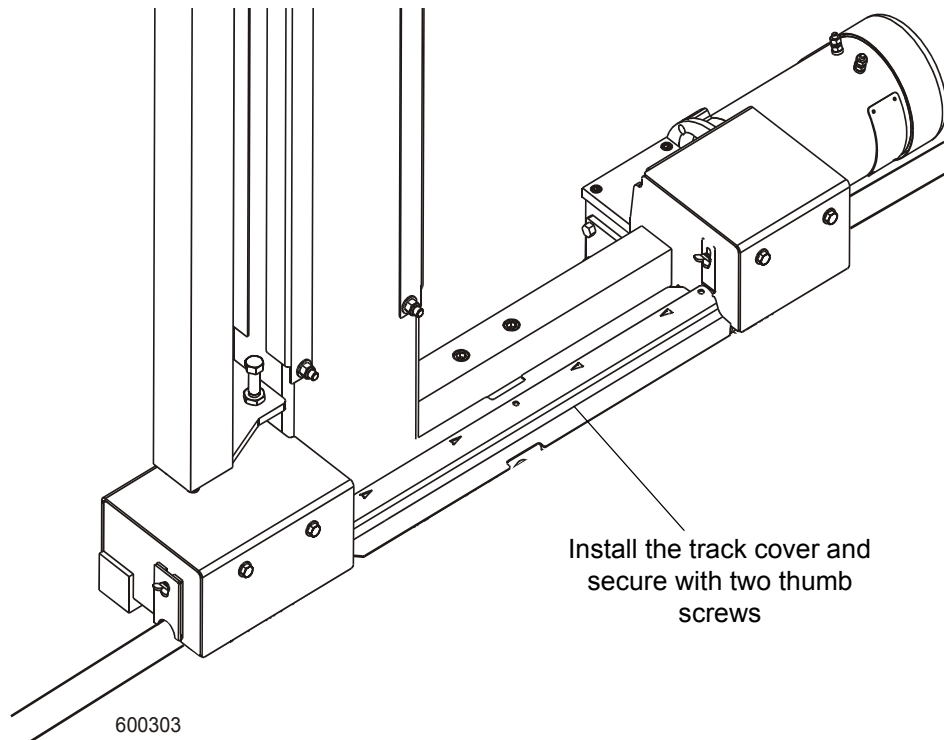

FIG. 2-5



CAUTION! Install the track cover so that it lightly touches the track rail. If the wiper presses too firmly against the rail, it can cause the power feed to bind.

2.5 Replacing The Blade



DANGER! Always disengage the blade and shut off the sawmill engine before changing the blade. Failure to do so may result in serious injury.



WARNING! Always wear gloves and eye protection when handling bandsaw blades. Changing blades is safest when done by one person! Keep all other persons away from area when coiling, carrying or changing a blade. Failure to do so may result in serious injury.

Adjust the blade guide arm all the way open.

Open the middle blade housing cover. Release the blade tension [See Section 2.6](#) until the wheel is pulled in and the blade is lying loose in the blade housing. Lift the blade out of the blade housing.

When installing a blade, make sure the teeth are pointing the correct direction. The teeth should be pointing toward the operator side of the mill when you are looking at the blade below the blade guides. Install the blade so it is lying around the wheels.



CAUTION! Be careful when placing the blade between the blade guide inserts. If the blade hits one of the inserts hard enough, it could damage the insert.

Position 1 1/4" wide blades on the wheels so the gullet is 3.0mm out from the edge of the wheel. Position 1 1/2" wide blades on the wheels so the gullet is 4.5mm out from the edge of the wheel.

Replace the blade housing cover.

Next, tension the blade correctly.

2.6 Tensioning the blade

Before tensioning the blade, check the air pressure gauge to see that the air tension system is properly charged. The gauge should read 44 PSI, i.e. 0.3 MPa (yellow colour) with the blade tension completely released. To add air pressure attach an air pump to the air valve. To release air, push in the valve stem.

See Figure 2-6.

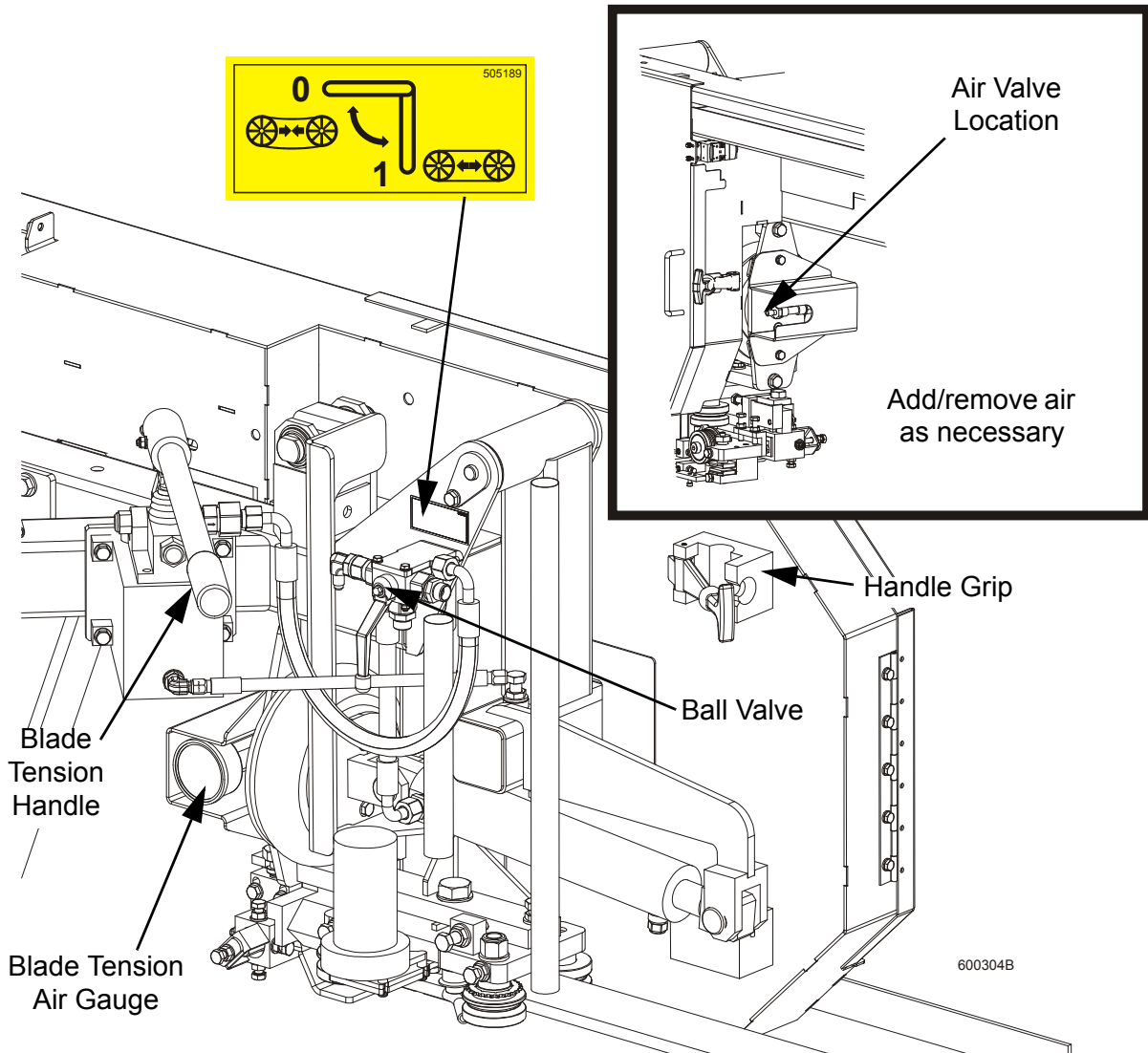

FIG. 2-6

To tension the blade use the tension handle, when the ball valve handle is in “1” working position. To release, shift the ball valve handle in “0” losing position. The blade tension handle should be placed in the handle grip when not use.

The tension gauge should be checked occasionally when adjusting the cant control or while cutting. Ambient temperature changes will cause tension to change. Adjust the tension handle as necessary to maintain

the recommended tension level.

See Table 2-6. The recommended tension for different blades is shown below.

Blade Type	Blade Dimensions		Tension range	
	Thickness (mm)	Width (mm)	PSI	MPa
2735	1,07	35	60-62	0,41-0,43
3735	1,14	35	65	0,45
276	1,07	38	60-62	0,41-0,43
376	1,14	38	62-65	0,43-0,45
576	1,27	38	65-70	0,45-0,48
476	1,4	38	65-70	0,45-0,48

TABLE 2-1

The tension gauge should be checked occasionally when adjusting the cant control or while cutting. Ambient temperature changes will cause tension to change. Adjust the tension handle as necessary to maintain the recommended tension level.



CAUTION! Release the blade tension when the mill is not in use (for example at the end of a shift). Tension the blade again before starting the motor.

2.7 Tracking the blade

1. Turn the key switch to #2 position.
2. Manually spin one of the blade wheels until the blade positions itself on the blade wheels.
3. Check if the blade is properly positioned on the blade wheels.

See Figure 2-7 Position 1 1/4" wide blades so the gullet is 3.0 mm out from the edge of the blade wheel ($\pm 1,5$ mm). Position 1 1/2" wide blades so the gullet is 4.5 mm out from the edge of the blade wheel ($\pm 1,5$ mm).

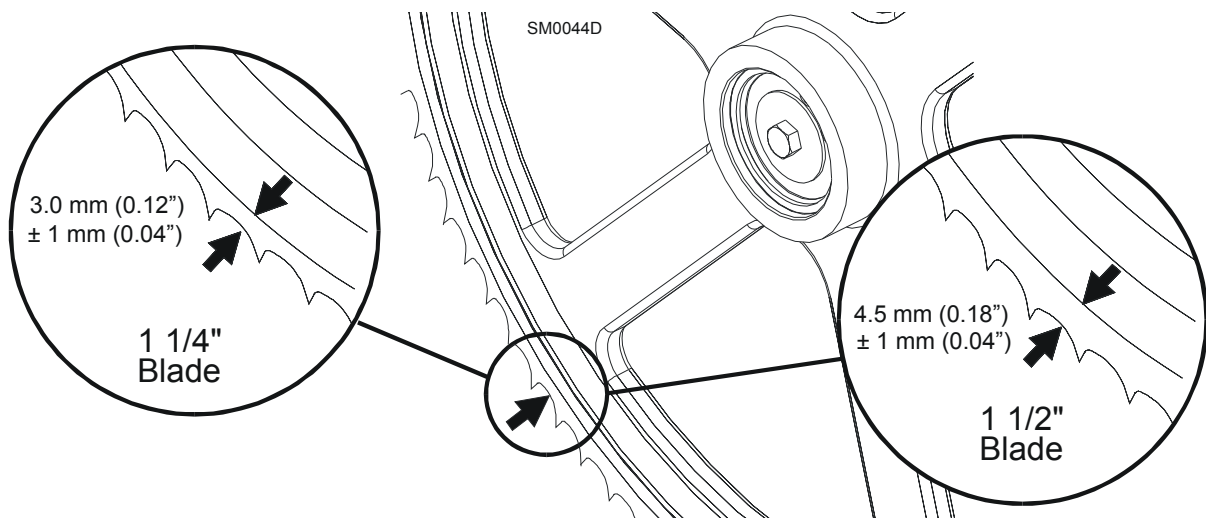

FIG. 2-7

4. Use the cant adjustment bolt to adjust where the blade travels on the blade wheels.

See Figure 2-8.

Turn bolt clockwise to move blade out on wheel,
counterclockwise to move blade in on wheel.

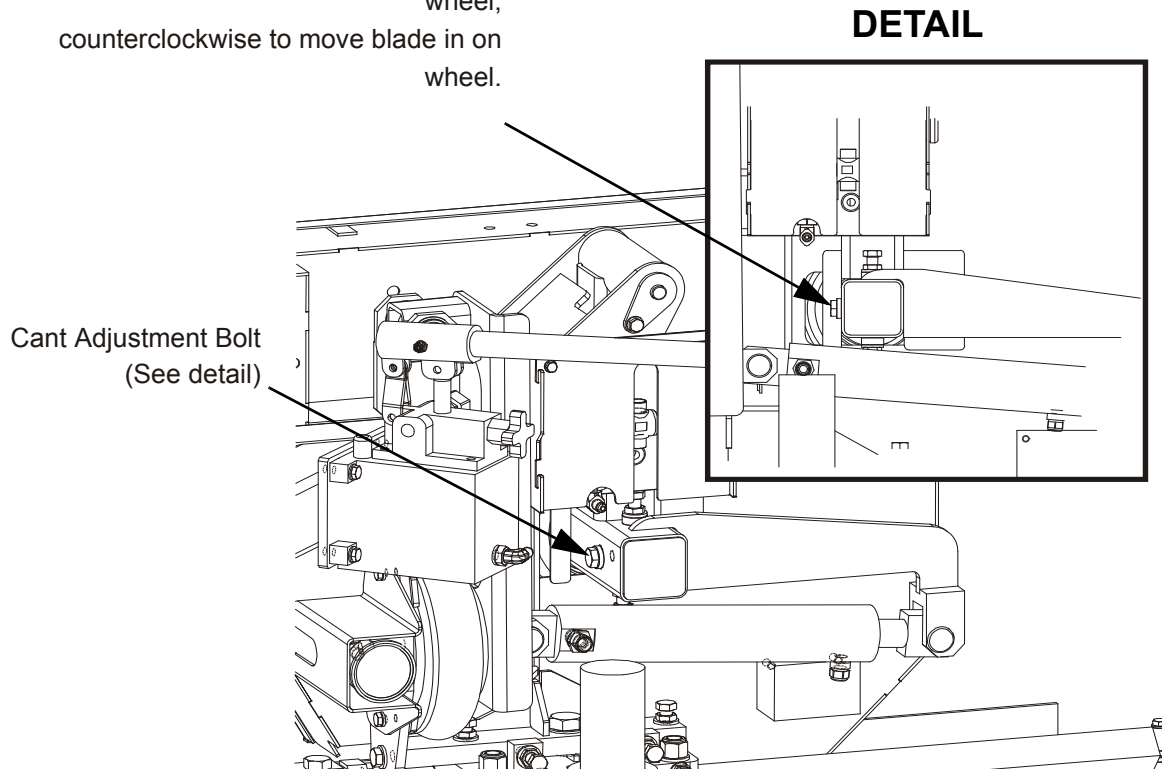

FIG. 2-8

To move the blade out on wheels, turn the cant adjustment bolt clockwise. To move the blade in on wheels, turn the bolt counterclockwise.

NOTE: Slight adjustments of the side bolts on the outer blade wheel are usually all that is necessary to track the blade properly. [See Section 5.3](#) for complete blade wheel alignment instructions.

5. Adjust the blade tension if necessary to compensate for any changes that may have occurred while adjusting the cant control.
6. Spin the blade wheel by hand.
7. Check if the blade is properly positioned on the blade wheels. Repeat steps 5 and 6 as necessary.
8. Turn the key switch to #0 position.
9. Be sure to close the blade housing and pulley covers when the adjustment is complete.



DANGER! MAKE SURE ALL GUARDS AND COVERS ARE IN PLACE AND SECURED before operating or towing the sawmill. Failure to do so may result in serious injury. Be sure the blade housing and pulley covers are closed (i.e. the safety switches located on them are engaged).



IMPORTANT! After aligning the blade on the wheels, always double-check the blade guide spacing and locations. (More informations - [See Section 5.3.](#))

2.8 Starting The Engine (or Motor)

See the appropriate manual supplied with your specific engine/motor configuration for starting and operating instructions.



DANGER! Make sure all guards and covers are in place and secured before operating or towing the sawmill. Failure to do so may result in serious injury. Be sure the blade housing and pulley covers are in place and secured, and the safety switches located on them are engaged. Use the safety retainer pin and cable to fasten blade housing covers.

DANGER! Always be sure the blade is disengaged and all persons are away from the blade before starting the engine. Failure to do so may result in serious injury.



WARNING! Always wear eye, ear, respiration and foot protection when operating the sawmill. Failure to do so may result in serious injury.

WARNING! Be sure the power feed switch is in the neutral position before turning the key switch to the on (#1) or accessory (#3) position. This prevents accidental carriage movement which may cause serious injury or death.

DANGER! Check the sawmill wiring every year. Make sure all electrical installation, service and/or maintenance work is performed by a qualified electrician.

WARNING! Hazardous voltage inside the electric box is dangerous. Turn the main switch to the OFF ("0") position and lock out power supply before opening the box door!

WARNING! The door of the electric box can be opened only when the main switch is in the "0" position. The door is closed when the switch is in the "1" position. Serious damage to the box may result while opening the door when the main switch is in the "1" position.



CAUTION! If at any time you need to immediately stop the blade motor, press the emergency stop button located on the control box. **CAUTION!** If at any

time you need to immediately stop the blade motor, press the emergency stop button located on the control box. **CAUTION!** If at any time you need to immediately stop the blade motor, press the emergency stop button located on the control box. **CAUTION!** If at any time you need to immediately stop the blade motor, press the emergency stop button located on the control box.

2.9 Hydraulic Control Operation

The hydraulic control levers become operational when the contacts at the bottom of the carriage touch the power strip on the frame tube. The hydraulic control levers will only work when the cutting head is close enough to the front end of the mill to touch the power strip.

See **Figure 2-9**. Sawmills equipped with A/DHS7 hydraulic system have fourteen control levers to load, clamp, turn and level logs.

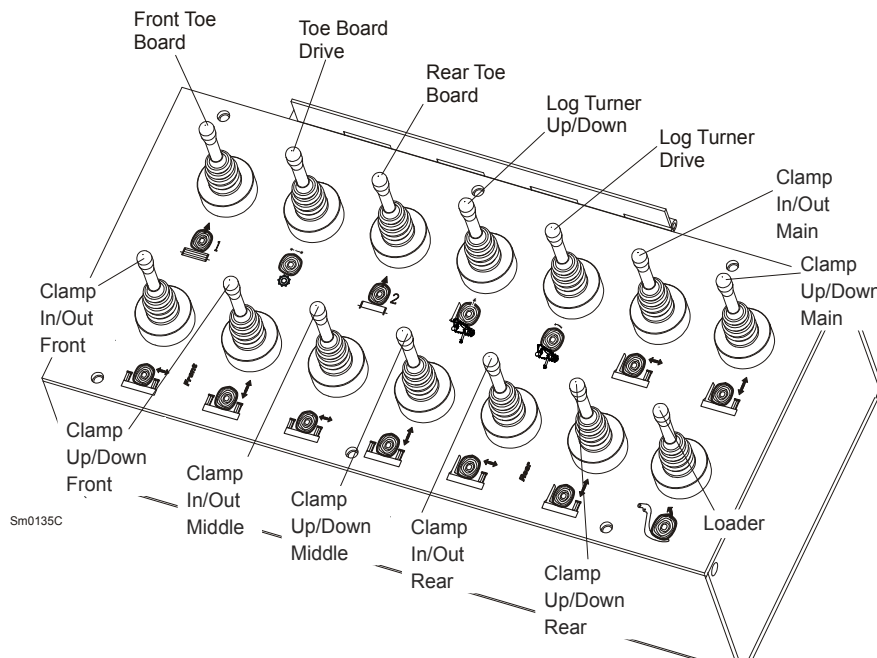

FIG. 2-9

Use the hydraulic control levers to get the mill ready to load a log.

DANGER! Keep all persons out of the path of moving equipment and logs when operating sawmill or loading and turning logs. Failure to do so may result in serious injury.

CAUTION! Always make sure the engine is running before operating the hydraulic controls. Operating the controls without the engine running will result in power drainage from the battery. Holding the hydraulic switches halfway up or down also will cause excessive drainage from the battery.

1. Move the clamp out and down so it will not get in the way of logs being loaded onto the bed.



Lower the clamp in/out lever to move the clamp out toward the loading side of the sawmill.



Lower the clamp up/down lever to lower the clamp below bed level.

2. Raise the log loader lever to extend the legs of the log loader out as far as they will go .



3. The chain securing the log loading arm to the log turner arm will be tight. Raise the log turner lever to raise the turner arm until there is slack in the chain.
4. Unchain the loading arm from the turner arm.
5. Manually lower the log loader so the legs rest on the ground.



CAUTION! Be careful when manually lowering the log loader. Do not drop the loader onto the ground.

6. Lower the loader lever to lower the loading arm as far as it will go. Logs must be rolled onto the loading arm one at a time for loading onto the bed of the mill.



7. The front and rear toe boards should be below bed level. Once a tapered log has been loaded, the front or rear end of the log may be lifted to parallel the heart of the log to the path of the blade.





The front toe board is raised by lifting the front toe board lever up. The rear toe board is raised by lifting the rear toe board lever up. Once a flat has been made and the log is ready to be turned, push the appropriate toe board lever down to lower either toe board until it falls below the level of the bed.

Use the power roller to move the log forward and backward.



2.10 Loading, Turning, And Clamping Logs

 **CAUTION!** Before loading a log, be sure the cutting head is moved far enough forward so the log does not hit it. Damage to the sawmill may result.

 **CAUTION!** Be sure the pivot rails, turning arm, clamp, and toe boards are below bed level before loading a log onto the bed. Failure to do so may result in machine damage or cause misalignment.

To Load Logs

1. Move a log up to the loading arm. Use cant hooks or loading equipment to move the logs to the foot of the loading arms.
2. Roll the log onto the loader so that it is approximately centered with the sawmill bed. The log turner will operate much easier if the log is centered on the sawmill bed.
3. Raise the side supports.



4. Raise the loader lever to raise the log onto the sawmill bed. Simply let the loader rise until the log rolls onto the mill bed.

5. Raise the clamp up (raise the clamp up/down lever) to prevent the log from rolling off the bed.

6. Lower the loading arm. Leave the loading arm about halfway up while squaring the log. This will stop the log from rolling off the side of the mill.

 **WARNING!** Always leave loading arm halfway up while log is on sawmill bed. Failure to do so will result in serious injury or death.

NOTE: Logs also may be loaded onto the mill with a tractor or other equipment specifically designed for that purpose.

7. Raise the clamp up to prevent the log from rolling off the bed.

8. Raise the clamp up/down lever.



To Turn Logs

1. Raise the side supports.
2. Raise the turner lever to engage the log turner arm.

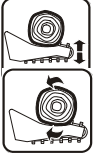

Spin the log against the side supports until it is turned the way you want it for the first cut.

4. Engage the clamp by raising the clamp in/out lever. Clamp the log against the side supports.



5. Lower the side supports.

6. Lower the turner lever to lower the turner arm below the log.

**To Turn Logs (Optional Procedure)**

If you are turning a small cant, you may opt to use the clamp to turn the cant.

1. Lower the clamp up/down lever to lower the clamp below bed level.
2. Raise the clamp in/out lever to move the clamp in, beneath the edge of the cant.
3. Raise the clamp up/down lever to raise the clamp and flip the cant.

To Clamp Logs

1. Raise the clamp up/down lever to raise the clamp.



2. Raise the clamp in/out lever and clamp the log against the side supports.

3. Lower the turner lever until the turner arm falls below the bed.



Use the clamp in/out lever, gently release the clamp.

5. Lower the side supports, to make few cuts.

6. Use the clamp in/out lever to clamp the log.

Depending on the log length, front and rear clamp (min. log length - 3.5m), or main clamp together with front or rear one (with logs shorter than 3.5m) can be used . They allow to find optimal position of the log on the bed, and prevent distortions during cutting.

1. Raise the front/rear clamp up/down lever to raise the clamp.



Raise the front/rear clamp in/out lever to clamp the log.



Use the middle clamp in/out lever to clamp the log against the side supports.



Lower the front/rear clamp up/down lever to lower the clamp, until the log lays flat on the bed.

To Level A Tapered Log

Use the toe board lever(s) to raise either end of a tapered log, if desired. Log can be moved forward or backward using the power roller.



Raise the appropriate lever to raise the front or rear toe board until the heart of the log measures the same distance from the bed rails at each end of the log.



2.11 Up/Down Operation

This section describes operation of the up/down system with the standard controls. See the operation section of the Networks or Accuset manual for operation of the up/down system using these options.

1. Install a blade, if needed, and check for correct blade tension. ([See Section 2.6](#)).
2. Set the cutting head to the desired height. (The blade height scale shows the height of the blade above the bed rails.)

 **See Figure 2-10.** The up/down switch is located on the far right side of the control panel. Push the switch up to raise the cutting head; push the switch down to lower the cutting head. Hold the switch in position until the cutting head reaches the desired height, then release.

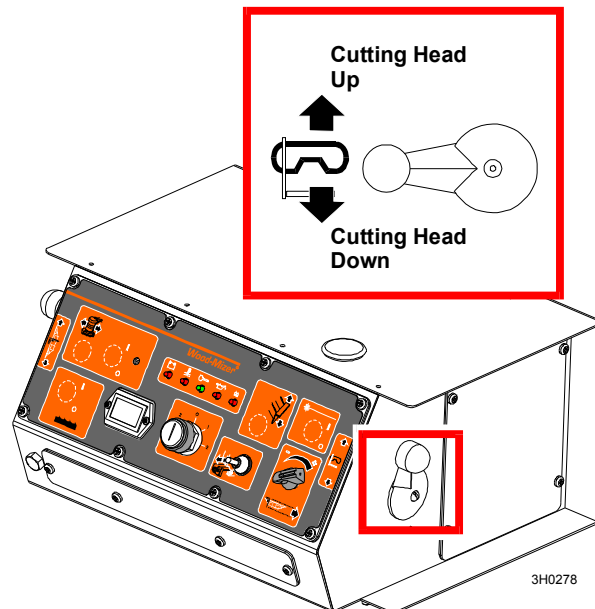

FIG. 2-10

The up/down switch is designed to return to the neutral or "off" position when released. If the switch remains engaged, manually move the switch to the neutral or "off" position. Repair the up/down drum switch. ([See Section 4.2](#)).



CAUTION! Always make sure the up/down switch moves to the neutral or "off" position when released to ensure that the saw head stops moving. Damage to the sawmill may result.

CAUTION! DO NOT try to force the carriage above the 35" (88 cm) mark or below the 1" (2.54 cm) mark. Damage to the up/down system may result.

2.12 Blade Guide Arm Operation

1. Look down the length of the log to see its maximum width. The outer blade guide should be adjusted to clear the widest section of the log by less than 1" (25.4 mm).
2. Use the blade guide toggle switch on the control panel to adjust the outer blade guide as necessary. Push the switch to the left to move the arm in. Push the switch to the right to move the arm out.

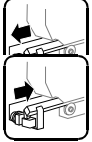

See Figure 2-11.

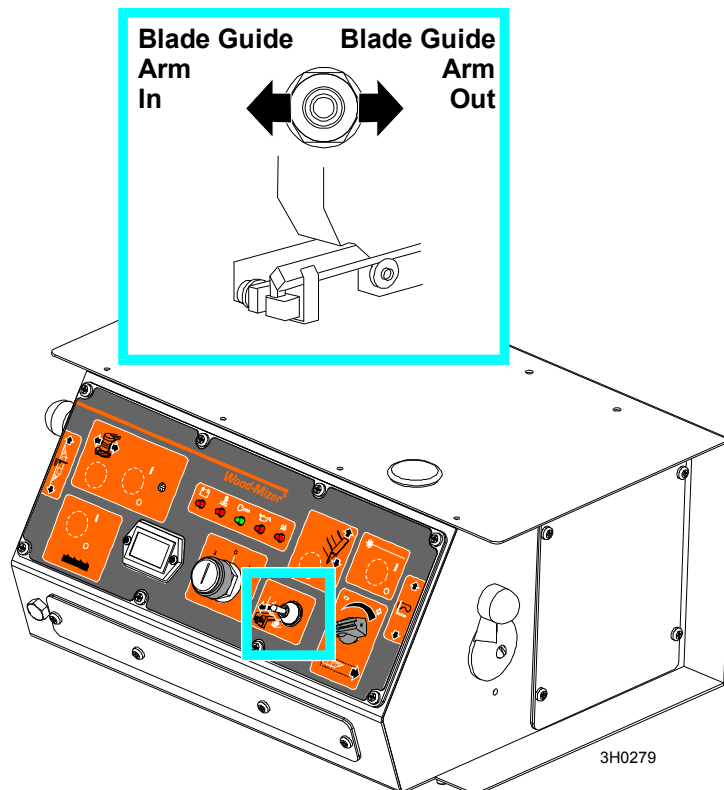

FIG. 2-11

3. Be sure to adjust the arm back out before returning the carriage.

2.13 Power Feed Operation

See Figure 2-12. The power feed system moves the carriage forward and backward by using two switches on the control panel.

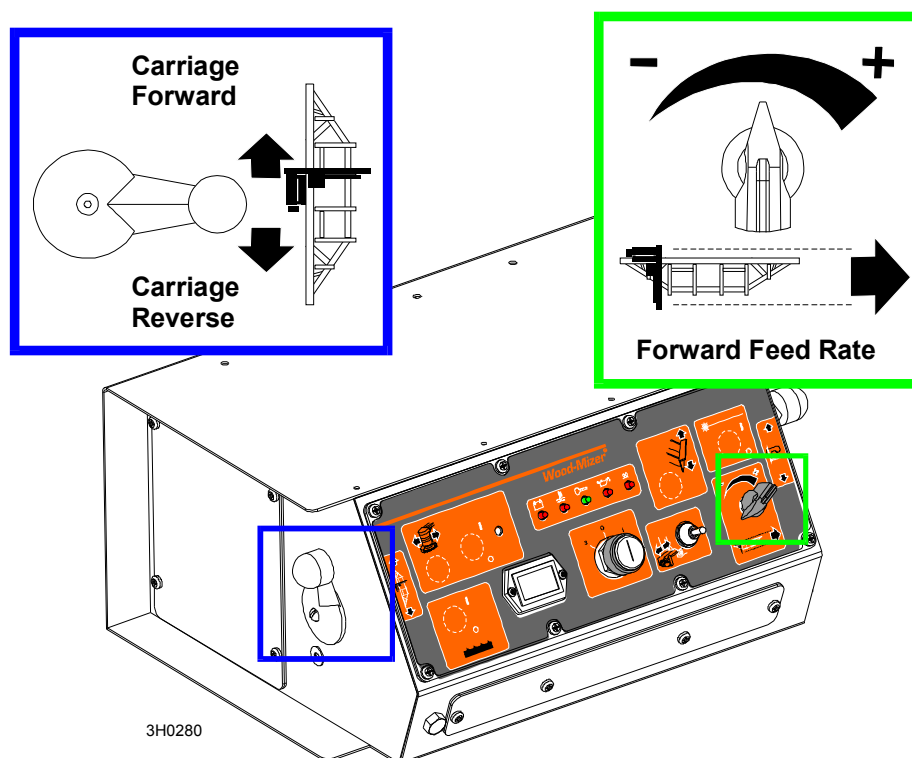

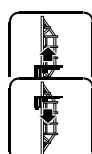

FIG. 2-12

Carriage Feed Rate

 The carriage feed rate switch controls the speed at which the carriage travels forward. Turn the switch clockwise to increase speed. Turn it counterclockwise to reduce speed.

Power feed operation

 The carriage forward/reverse switch controls the direction in which the carriage travels. Turn the forward/reverse switch upward to move the carriage forward. Turn the switch down to move the carriage backward.

The middle position (shown in the figure above) is the neutral position. The power feed switch is designed to return to the neutral or "off" position when released from operating in the reverse position. If the switch remains engaged, manually move the switch to the neutral or "off" position. Repair the drum switch ([See Section 4.2](#)).

 **WARNING!** Be sure the power feed switch is in the neutral position before turning the key switch to the on (#1) or accessory (#3) position. This prevents accidental carriage movement, which may cause serious injury or death.

Using The Power Feed

1. To move the carriage forward, push the drum switch handle forward and turn the feed rate switch clockwise.

 **HINT:** To get a straight cut in the first part of the board, feed the blade into the log at a slow speed. This stops the blade from flexing and dipping up or down. Turn the carriage feed rate switch to a slow speed until the whole width of the blade has entered the cut. Then use the carriage feed rate switch to increase the feed rate as desired. Maximum feed rate varies with width and hardness of the wood. Over-feeding results in engine and blade wear.



2. Stop the carriage at the end of the cut by turning the carriage feed rate switch counterclockwise until the carriage stops moving. Disengage the clutch/brake lever up or the optional blade switch down to stop the blade and drop the engine to idle. Remove the board that you have just cut from the log. **Always disengage the blade before returning the carriage for the next cut.**



 **CAUTION!** Be sure to stop the blade when returning the carriage. This will not only prevent the blade from being pulled off and ruined by a wood sliver, but also will increase the life of the blade.

3. Make sure that the blade does not catch on the end of the log. Raise the carriage slightly to make sure the blade clears the log when returned.

4. Return the carriage to the front of the mill by pushing the drum switch handle down. The power feed motor will bypass the carriage feed rate switch and the carriage will automatically return at the fastest speed available.



5. **HINT:** Try to stop the blade while the heel of the blade is still on the log. Then bring the carriage back without adjusting the blade up. This lets you keep the blade at the current height setting so you can make the next blade height adjustment more quickly.

 **DANGER!** Stay clear of the area between the trailer axle and saw carriage. Failure to do so may result in serious injury.

2.14 Cutting The Log

The following steps guide you through normal operation of the Wood-Mizer sawmill.

1. Once the log is placed where you want it and clamped firmly, turn the key switch to the accessory (#1) position.



2. Use the blade height scale to determine where to make your first cut ([See Section 2.18](#)). The blade height scale will help you to do this. Set the blade to the desired height with the up/down switch. Make sure that the blade will clear all side supports and the clamp. Adjust the outer blade guide to clear the widest section of the log by moving the blade guide toggle switch.



NOTE: An optional laser sight is available to help determine where the blade will travel through the log. See the laser sight manual for detailed operating instructions.

3. Make sure all covers and guards are in place. Start the engine.

4. Start the water lube if necessary to prevent sap buildup on the blade. [See Section 2.19](#).



5. If you want to use the board return function, push the toggle switch on the control panel down. [See Section 2.9](#).



Feed the blade into the log slowly ([See Section 2.13](#)). Once the blade completely enters the log, increase the feed rate as desired. Always try to cut at the fastest speed you can while keeping an accurate cut. Cutting too slowly will waste blade life and lower production!



As you get to the end of the log, slow down the feed rate. When the teeth exit the end of the log, turn the feed rate all the way down and turn the blade switch to "0" position. Remove the slab that you have just cut from the log.



8. Use the carriage forward/reverse switch to return the carriage to the front of the mill. Always disengage the blade before returning the carriage for the next cut.

9. Repeat until the first side of the log is cut as desired. Set aside the usable flitches (boards with bark on one or both sides). You can edge them on the mill later.



10. Lower the toe boards, if they were used. Use the hydraulic levers to release the clamp and engage the log turner. Turn the log 90 or 180 degrees. Make sure the flat on the log is placed flat against side supports if turned 90 degrees. Make sure it is placed on bed rails if turned 180 degrees. If the log was turned 90 degrees and you are using toe boards to compensate for taper in the log, raise the front or rear toe board again on the second side of the log until the heart is parallel with the bed.

11. Repeat the steps used to cut the first side of the log until the log is square. Cut boards from the remaining cant by adjusting the blade height for the thickness of boards that you want.

Example: Remember that the blade cuts a 1/16 - 1/8" (1.6-3.2 mm) wide kerf. If you want 1" (25.4 mm) thick boards, lower the carriage 1 1/16 - 1 1/8" (27-28.6 mm) for each board.

2.15 Wireless Control Panel (option)

See Wireless Option Manual.

2.16 Edging

The following steps guide you through edging boards on the Wood-Mizer sawmill.

1. Raise the side supports to 1/2 the height of the flitches, or the boards that need to be edged.
2. Stack the flitches on edge against the side supports.
3. Clamp the flitches against the side supports halfway up the flitch height. (Wider flitches should be placed to the clamp side. When they are edged, flip them over to edge the second side without disturbing the other flitches or without having to pull them from the middle of the stack).
4. Adjust the blade height to edge a few of the widest boards.
5. Loosen the clamp and turn the edged boards over to edge the other side.
6. Repeat steps 2-4.
7. Loosen the clamp and remove the boards that have good clean edges on both sides. Clamp the remaining flitches and repeat steps 2-5.

2.17 Optional Cutting Procedure

In order to achieve maximum production rates with Super Series mills; it may be desirable to leave the blade engaged when returning the carriage. (Normal operation procedures recommend disengaging the blade before returning the carriage for maximum blade life and fuel economy.)

DANGER! If leaving the blade engaged for maximum production rates, make sure the off-bearer stays out of the path of the blade. Failure to do so will result in serious injury or death.

CAUTION! If you choose to leave the blade engaged; raise the blade to clear the log before returning the carriage. Failure to do so may cause damage to the blade and/or sawmill.

2.18 Blade Height Scale

See Figure 2-13. The blade height scale is attached to the carriage head frame. It includes:

- a blade height indicator
- an inch scale
- a quarter scale

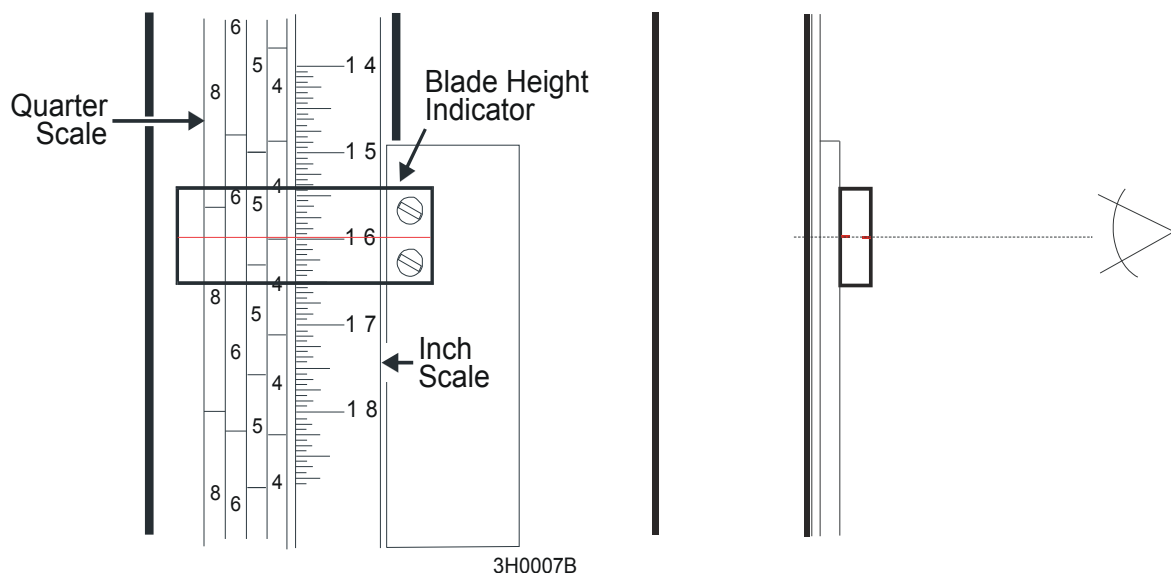

FIG. 2-13

The scales are attached to the frame and move up and down with the carriage head. The blade indicator, used to read the inch and quarter scales, remains stationary.

Blade Height Indicator

The blade height indicator has two horizontal, red lines on both sides. Readings should be taken with eyes level with the indicator, when the two red lines are in line. This will allow to avoid the parallax error (different scale readings depending on the angle of vision).

The inch scale

The horizontal red line on the blade height indicator shows how many inches the bottom of the blade is above the bed of the mill. If you know the height of your blade at each cut, you can determine the thickness of lumber you are sawing.

Example: You want to cut 1" (25 mm) random width boards from a log. Position the blade for the first cut. Move the carriage to an even measurement on the inch scale. Make a trim cut. Return the carriage for the second cut and lower it 1 1/8" (29 mm) below the original measurement.

The yellow area on the scale identifies where the blade could encounter a side support or log clamp. Check that these items are below the blade level before sawing

The Quarter Scale

See Table 2-7. The LT70 sawmills are equipped with two quarter scales: Standard Quarter Scale and Grade Hardwood Quarter Scale. Both scales are provided with four sets of marks. Each set represents a specific lumber thickness. Saw kerf and shrinkage allowance are included, but actual board thickness will vary slightly depending on blade thickness and tooth set.

To choose which scale to use, determine what finished thickness you want to end up with. The Grade Hardwood Quarter Scale provides thicker finished boards usually required by commercial buyers. The Standard Quarter Scale allows for kerf and shrinkage of finished boards suitable for most custom applications. Always check with your customer before you saw to determine what actual finished thickness is required.

Standard Quarter Scale		Grade Hardwood Quarter Scale	
Scale	Actual Board Thickness	Scale	Actual Board Thickness
4/4	1" (25 mm)	4/4	1 1/8" (29 mm)
5/4	1 1/4" (32 mm)	5/4	1 3/8" (35 mm)
6/4	1 1/2" (38 mm)	6/4	1 5/8" (41 mm)
8/4	2" (51 mm)	8/4	2 1/8" (54 mm)

TABLE - 0-1

To use the quarter scale, look at the blade height indicator. Line up the horizontal red line on the indicator with the nearest mark on the scale you want to use. Make a trim cut. When you return the carriage for a second cut, lower the carriage to the next mark on the scale. This mark shows where the blade should be positioned to cut a certain thickness of lumber, without having to measure on the inch scale.

Example: You want to cut 1" (25 mm) (4/4) random width boards from a log. Position the blade for the first cut. Adjust the quarter scale so a 4/4 mark is aligned with the red line on the indicator. Make a trim cut. Return the carriage for the second cut. Now, instead of having to measure down 1 1/8" (29 mm) on the inch scale, you can simply lower the blade so the indicator is aligned with the next 4/4 mark on the quarter scale. Turn the log 90 degrees and repeat.

2.19 Water Lube Operation

See Figure 2-14. The Water Lube System keeps the blade clean. Water flows from a 5-gallon (18.9 liter) bottle through a hose to the blade guide where the blade enters the log. A valve in the bottle cap controls the amount of water flow.

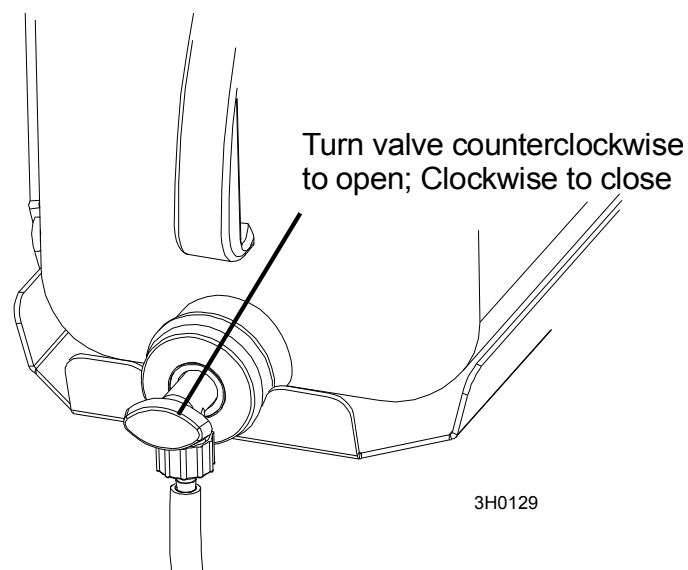

FIG. 2-14

LT70 Series sawmills include a solenoid valve that will automatically start the water flow when the power feed is activated in the forward direction. The solenoid will stop the water flow when the feed switch is returned to the neutral position.

Not all types of wood require the use of the Water Lube System. When it is needed, use just enough water to keep the blade clean. This saves water, and lowers the risk of staining the boards with water. Usual flow will be between .07 and 2.5 gallons (3.8 -7.6 liters) per hour. A squirt of liquid dishwashing detergent in the water bottle will help clean the blade when cutting wood with a high sap content.



WARNING! Use **ONLY** water with the water lube accessory. Never use flammable fuels or liquids. If these types of liquids are necessary to clean the blade, remove it and clean with a rag. Failure to do so may result in serious injury or death.

Before removing the blade, engage the clutch/brake lever. Let the blade spin with water running on it for about 15 seconds. This will clean the blade of sap buildup. Wipe the blade dry with a rag before storing or

sharpening.

If you are sawing in freezing temperatures, remove the water lube bottle from the sawmill when done sawing and store it in a warm place. Blow any remaining water from the water lube hose.

To remove water from the water valve on LT70 sawmills, turn the key switch to accessory, turn the feed rate knob down to '0' and place the feed switch in the forward position. Blow any remaining water from the water lube hose and valve. Return the forward/reverse switch to neutral and turn the key switch to off (#0).

NOTE: If your sawmill is equipped with LubeMizer System, please refer to LubeMizer Operation Manual.

2.20 Preparing The Sawmill For Transportation

The Wood-Mizer trailer package for the LT70 sawmills makes transporting your sawmill easy and convenient. To get your sawmill ready for towing, follow these instructions.

1. Move the saw carriage to the front end of the sawmill. Raise the rear outriggers.
2. Move the clamp to the main bed rail as close as possible.



CAUTION! Move the hydraulic clamp and turner to provide maximum ground clearance before towing. Failure to do so may result in damage to the sawmill.

3. Move the carriage forward to the travel position over the bed rail. Position the hole in the saw head over the travel rest pin.
4. Secure the rest pin using locking pin.

See Figure 2-15.

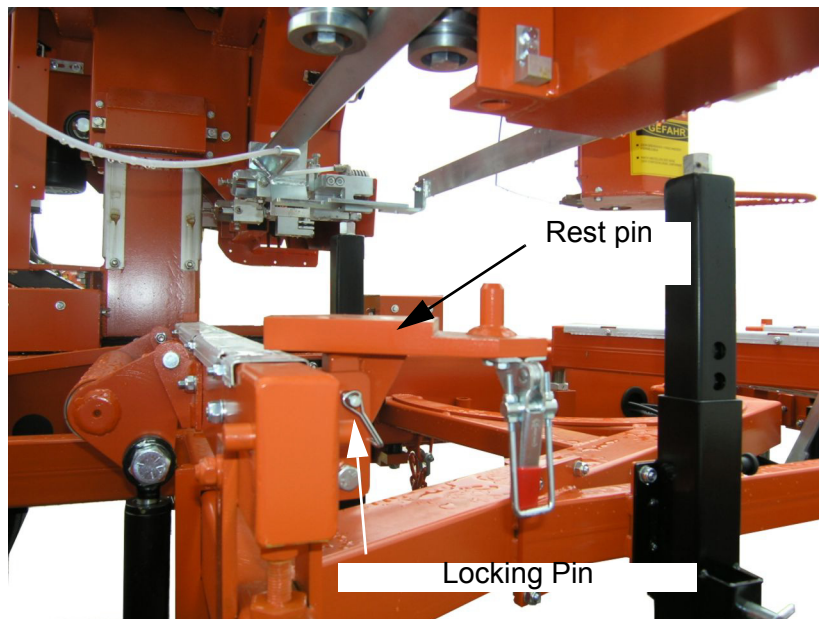

FIG. 2-15

5. Lower the saw head until it contacts the stop blocks on the mast rails. Secure the saw head with locking clamp.

See Figure 2-16.

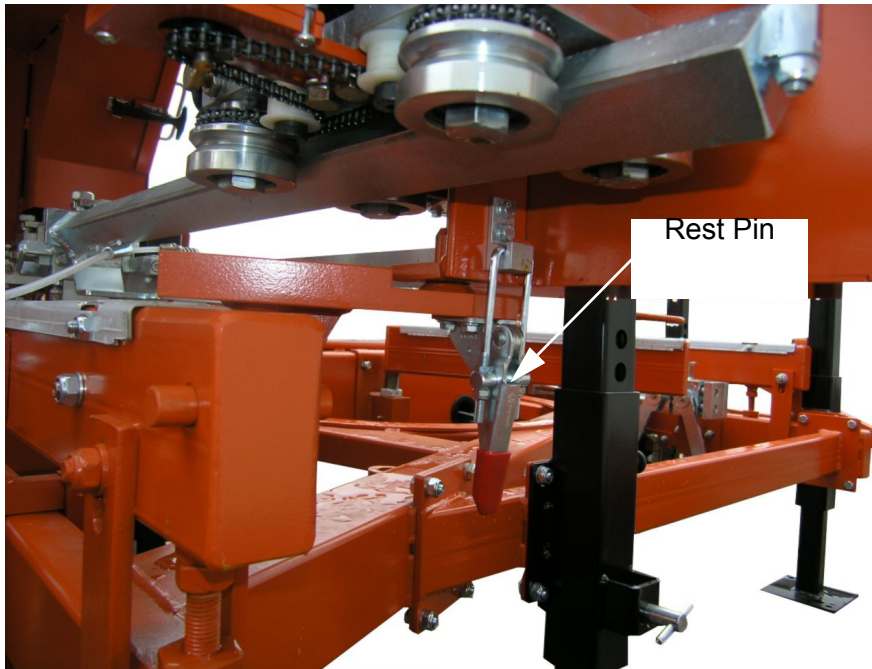

FIG. 2-16



CAUTION! It is important that the lower stop bolts are properly adjusted to secure the carriage on the track rail. Failure to properly adjust the stop bolts can cause saw head damage, especially during mill transportation.

- If necessary, adjust the two stops located at the bottom of the mast so the saw head contacts them after it is lowered $\frac{3}{4}$ " (19mm) past where it contacts the rest pin.

See Figure 2-17.

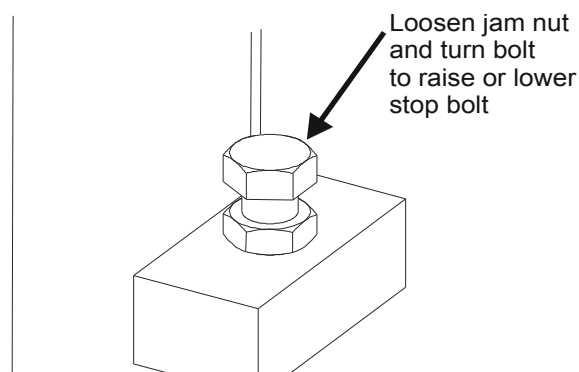

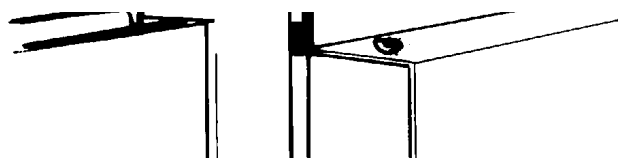

FIG. 2-17

- Use the  ulic controls to raise the log turner and loader as high as they will go. Manually lift the loader



SECTION 3 MAINTENANCE

This section lists the maintenance procedures that need to be performed.



WARNING! Disconnect and lock out power supply before servicing, cleaning and doing maintenance to the saw! Failure to do so may result in serious injury.

The Short Interval Maintenance Schedule lists procedures that need to be performed every 4, 8 or 24 hours. The Maintenance Log lists procedures that need to be performed every 50, 100, 200, or 1000 hours. Keep track of machine maintenance by filling in the machine hours and the date you perform each procedure.



This symbol identifies the interval (hours of operation) which each maintenance procedure should be performed.

This sections lists only part of the maintenance procedures that need to be performed in LT70 sawmills. Be sure to refer to option and engine manuals for other maintenance procedures.

3.1 Wear Life

See Table 3-1. This chart lists estimated life expectancy of common replacement parts if proper maintenance and operation procedures are followed. Due to the many variables which exist during sawmill operation, actual part life may vary significantly. This information is provided so that you may plan ahead in ordering replacement parts.

Part Description	Estimated Life
B72.5¹ Blade Wheel Belts	500 hours
Up/Down Motor	2000 hours
Drum Switch, Up/Down Motor	1000 hours
Blade Guide Rollers	1000 hours
Power Feed Drum Switch	1200 hours
Drive Belt	1250 hours
Power Feed Motor	1500 hours
Power Feed Drive Belt	2000 hours
Up/Down Belt	2000 hours

TABLE - 0-1

¹ To insure proper blade tracking, use Goodyear, Dayco Super II, or Browning belts only.

3.2 Blade Guides

1. Check the rollers for performance and wear every blade change. Replace any rollers which have worn smooth or have become cone shaped. Make sure the rollers are clean and spinning freely. If not, rebuild them.

Steel Guide Blocks

2. Inspect the blocks at every blade change for damage or wear.

As the blocks wear, the front inside corner will wear more than the body of the block. When the corner wears far enough, sawing performance will be affected even if the body of the block is adjusted properly to the blade. At this point, the block should be replaced. If you have access to the appropriate equipment, you can grind or mill the blocks to a new flat surface and reuse them. It is recommended you develop a routine schedule for replacing the blade guide blocks based on your sawing conditions and experience.

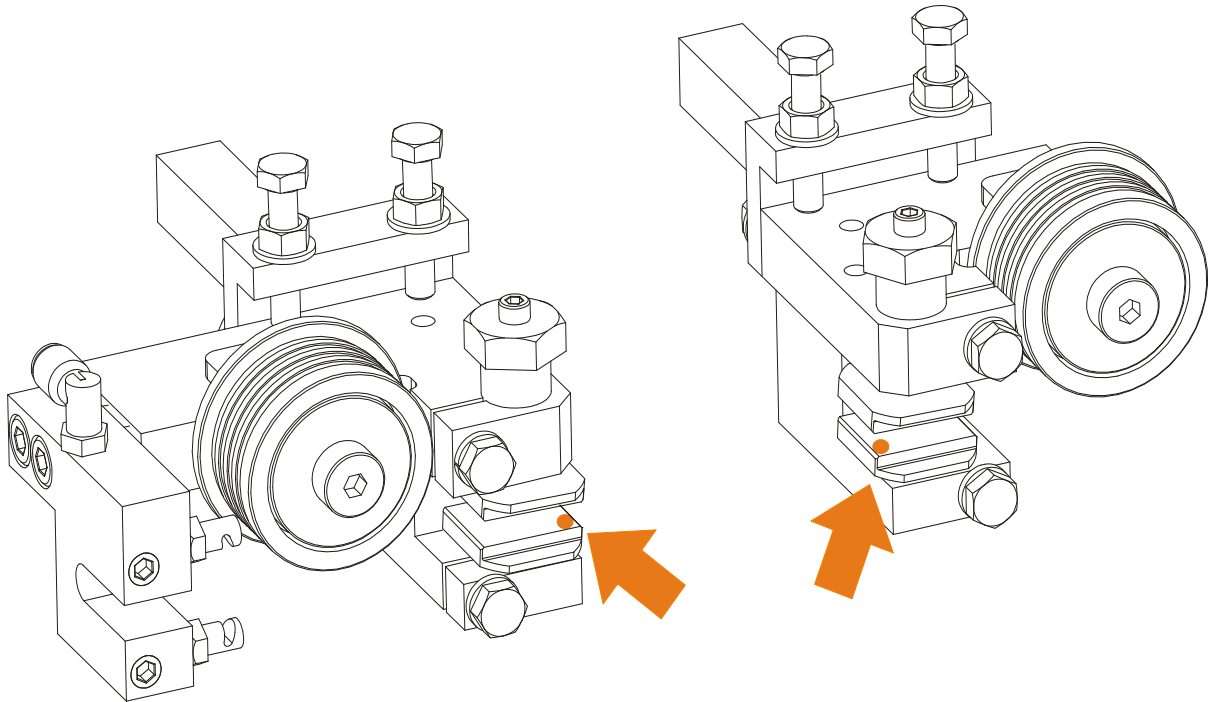

FIG. 3-0

3. Check the inserts are properly spaced from the bottom of the blade every 25 hours of operation. As the rollers wear, the gap between the blade and inserts will become larger. Use the provided shim or a feeler gauge to check the inserts are adjusted 0,3 - 0,5 mm from the blade.

25

See Figure 3-1. To adjust the disks up, loosen the bottom guide disk mounting bolt and clamp bolt. Use the provided adjustment tool. to raise bottom disk Retighten the bottom disk mounting bolt and clamp bolt. [See Section Blade Disk Adjustment](#)

IMPORTANT! The disks should be parallel to the blade. Check the space between the disks and the blade at each side of the disks to insure it is parallel. Use the appropriate adjustment bolt to tilt the disks mounting plate so the insert is parallel to the blade.

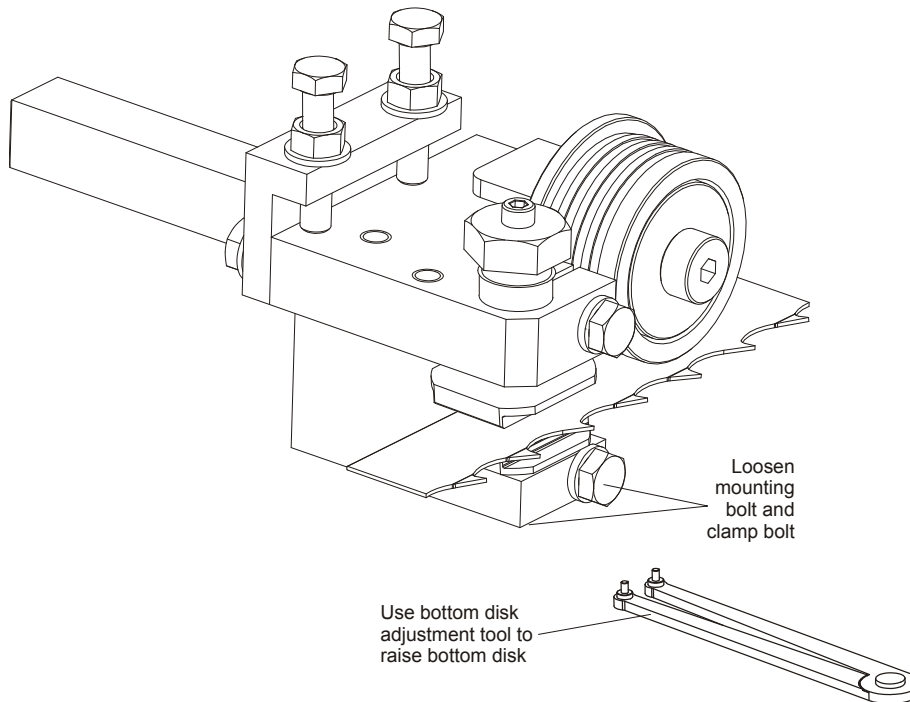

FIG. 3-1

A/R Inspect the blade guide assemblies for proper alignment every time you change the blade. [See Section 3.2 Blade Guides](#) for blade guide adjustment instructions..

WARNING! Blade guide alignment is essential for optimal cutting performance, blade life and safety. Failure to check and maintain proper blade guide alignment will result in stress cracks forming in the blade. These cracks will lead to premature blade breakage. If the blade breaks during operation and the blade has multiple stress cracks, the blade could shatter into several pieces and escape from the protective guards of the sawmill. Small blade pieces projected into the area around the sawmill creates a safety hazard for the operator and any bystanders surrounding the mill.

WARNING! DO NOT use blades with stress cracks. Blades with stress cracks can shatter causing bodily injury and/or machine damage.

Preventing sap buildup on the blade is critical when using the high-performance blade guide system. If the wood you are sawing leaves sap buildup using plain water in the blade lube system, use Wood-Mizer lube additive (Part No. 033439).

Throat Screw

3

MAINTENANCE

Blade Guides

Make sure the blade screw in the top center of the C-frame is 1/16" (1.5 mm) away from the blade. If not, loosen the nut and adjust the screw as necessary. Check the screw every blade change. Failing to maintain this adjustment will lead to early blade breakage.

See Figure 3-2.

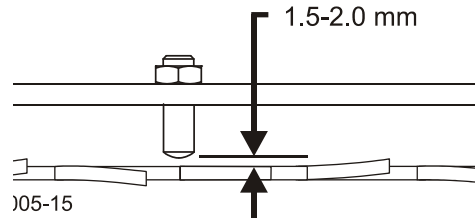

FIG. 3-2

3.3 Sawdust Removal

1. Remove the excess sawdust from the blade wheel housings and sawdust chute every blade change.
- 8 2. Remove all sawdust and debris from around the velocity fuse valves every 8 hours of operation. The valves are located at the bottom of the log loader cylinders. Remove sawdust buildup as necessary from the battery box lid and top rail cover. Remove sawdust buildup as necessary from the rail cover.

Failure to remove sawdust buildup from the battery box lid and/or track rail cover could result in damage to these parts when the saw head is lowered to its lowest position.

3.4 Carriage Track, Wiper & Scrapers

Properly maintaining the sawmill carriage track is critical in preventing corrosion that can cause pitting and scaling on the rail surfaces. Pitted and scaled surfaces can, in turn, cause rough cuts or jerky power feed movement.

See Figure 3-3.

- 8 1. Clean track rails to remove any sawdust and sap buildup every eight hours of operation.

Use a light-grade sandpaper or emery cloth to sand off any rust or other adhering particles from the rails.



CAUTION! Keep track rails free of rust! Formation of rust on the track rail in the areas where the cam bearings roll can cause rapid deterioration of the track rail's surface.

Lubricate the rails by wiping them with Dexron III ATF transmission fluid, 10W30 motor oil, or 3-in-1 turbine oil. Oil lubrication will help protect the rails from corrosive elements such as acid rain and/or moisture from nearby bodies of saltwater (if applicable). This lubrication is essential to maintain the integrity of the track rails and track rollers and to achieve long service life.

- 25 2. Remove sawdust from the track roller housings and lubricate the felt track wiper every twenty-five hours of operation.

Remove the track roller housing covers and brush any sawdust buildup from the housings.

3. Check the track scrapers as needed. Make sure the scrapers fit firmly against the rail. If a track scraper needs to be adjusted, loosen the thumb screw, push the scraper downward until it fits firmly against the rail, and retighten the thumb screw.

- 25 Clean and lubricate the upper track wiper every twenty-five hours of operation. Unbolt the wiper, remove it from the sawmill, and remove any sawdust buildup. Soak the felt wiper with Dexron III transmission fluid, 10W30 motor oil or 3-in-1 turbine oil.



CAUTION! Reinstall the track wiper so that it lightly touches the track rail. If the wiper presses too firmly against the rail, it can cause the power feed to bind.

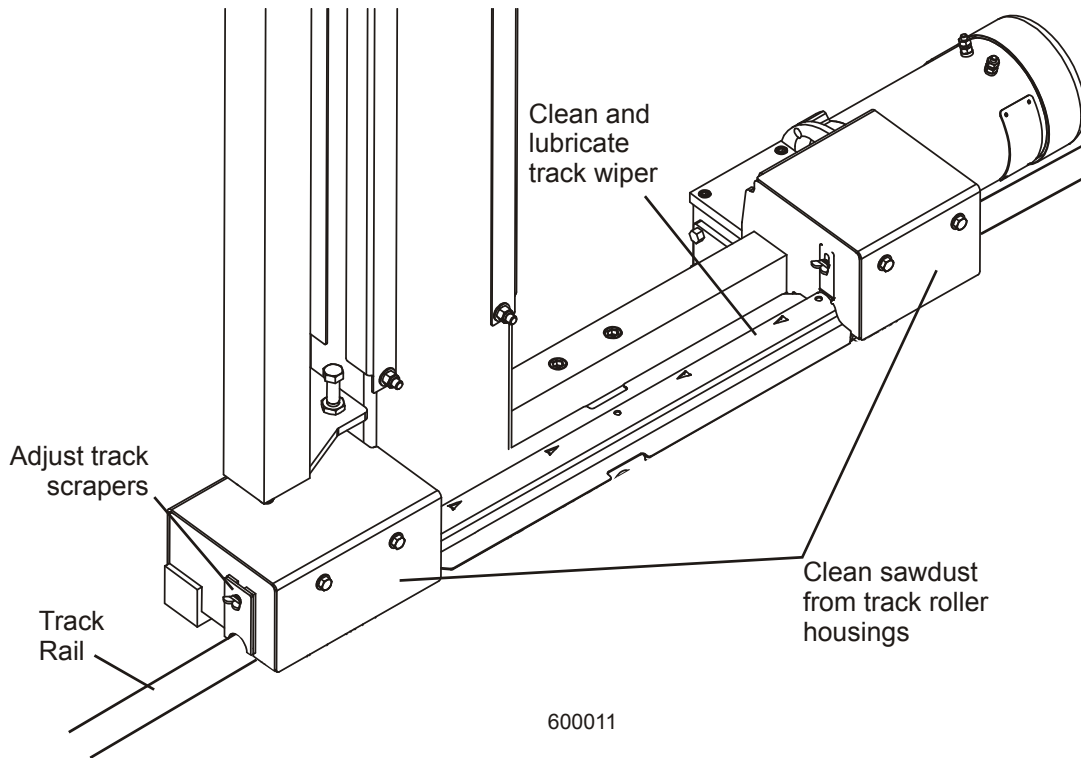

FIG. 3-3

3.5 Vertical Mast Rails

50 Clean and lubricate the vertical mast rails every 50 hours of operation. Clean with solvent and remove any rust with a light-grade sand paper or emery cloth. Lubricate the mast with motor oil or automatic transmission fluid (ATF).



CAUTION! Never use grease on the mast rails as it will collect sawdust.

3.6 Drum Switches

50 Lubricate the up/down and power feed drum switch contacts inside the control panel every fifty hours of operation. Use only contact grease supplied by Wood-Mizer. Remove the control panel cover. Use a cotton swab to apply grease to the switch contact ends.



WARNING! Drum switch grease contains Petroleum Hydrocarbon Lubricant. Eye and skin irritant. If introduced into eyes, flush with water for at least 15 minutes. If film or irritation persists, seek medical attention. Wash skin with soap and water. If ingested, do not induce vomiting - contact a physician. KEEP OUT OF THE REACH OF CHILDREN.

3.7 Miscellaneous Maintenance

50 1. Oil all chains with Dexron III ATF every fifty hours of operation.



CAUTION! Do not use chain lube. It causes sawdust buildup in chain links.

50 2. Apply a thin film of a NLGI No. 2 grade lithium grease to the blade guide arm every fifty hours of operation to help prevent it from rusting.

AR 3. Adjust the blade guide arm drive chain as necessary. To adjust the chain, loosen the blade guide arm motor mounting plate bolts and slide the motor to take slack out of the chain.

50 4. Grease the clamp mechanism, loading arms, and side supports with a NLGI No. 2 grade lithium grease every fifty hours of operation.

50 5. Lubricate the board return pivot every fifty hours of operation with a NLGI No. 2 grade lithium grease. Apply grease to the grease fitting on the board return pivot tube.

6. Check the mill alignment every setup. See Section 5, Alignment.

7. Make sure all safety warning decals are readable. Remove sawdust and dirt. Replace any damaged or unreadable decals immediately. Order decals from your Customer Service Representative.

3.8 Drive Belt Adjustment



DANGER! Never adjust the drive belts while the engine is running. Failure to do so may result in serious injury.



Periodically check the drive belt for wear. Replace any damaged or worn belts as needed.

See Figure 3-4. Adjust proper drive belt tension using the bolt located between the drive side wheel covers. To tighten drive belt turn the bolt clockwise. To loosen drive belt turn the bolt counter clockwise.

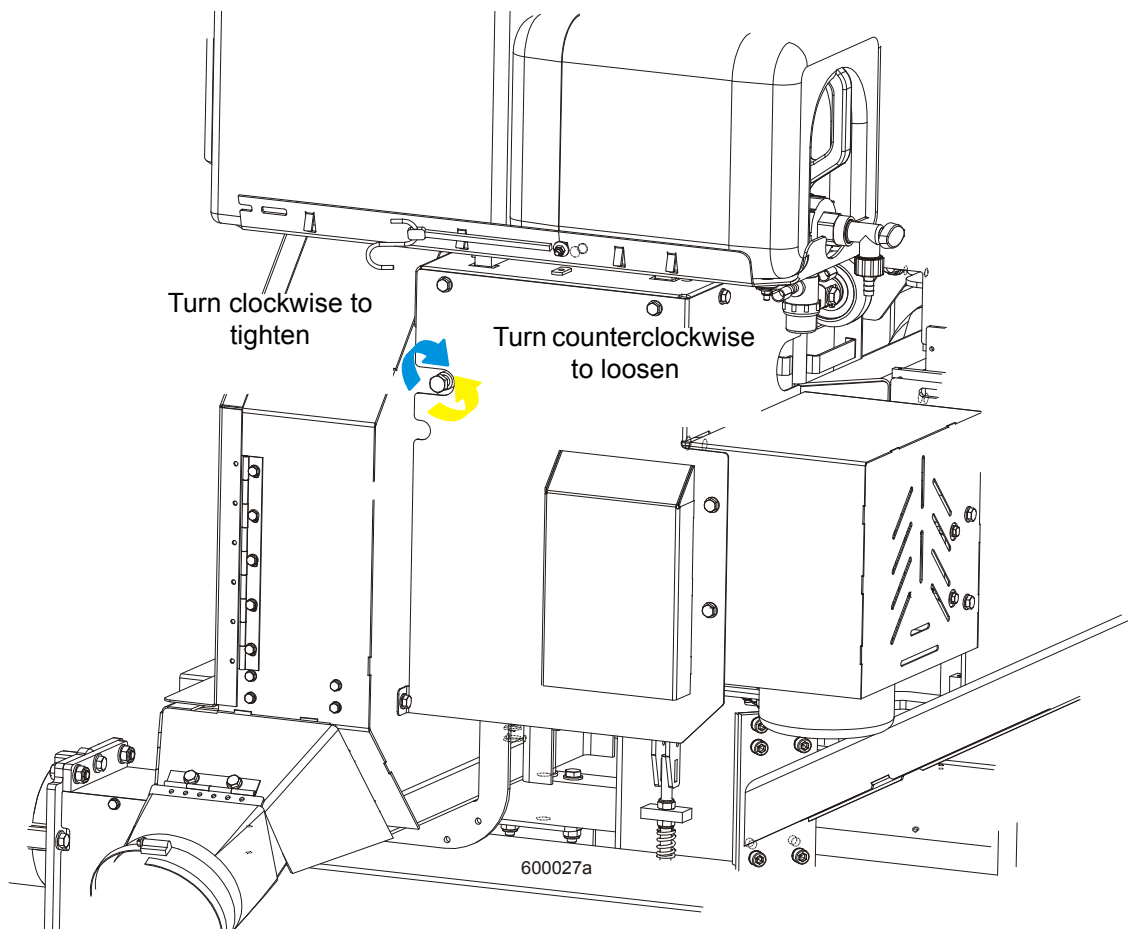

FIG. 3-4

3.9 Up/Down System

750

Adjust the up/down chain tension as needed. Measure chain tension with the head all the way to the top of the vertical mast. Find the chain adjusting bolt at the bottom of the mast. Use the adjustment nut to adjust the bolt until the center of the chain can be deflected 3/4" (1.9cm) with a 5 lb. (2.3 KG) deflection force..



CAUTION! Do not over-tension the chain. Over-tensioning the chain may lead to early failure of the gear reducer.

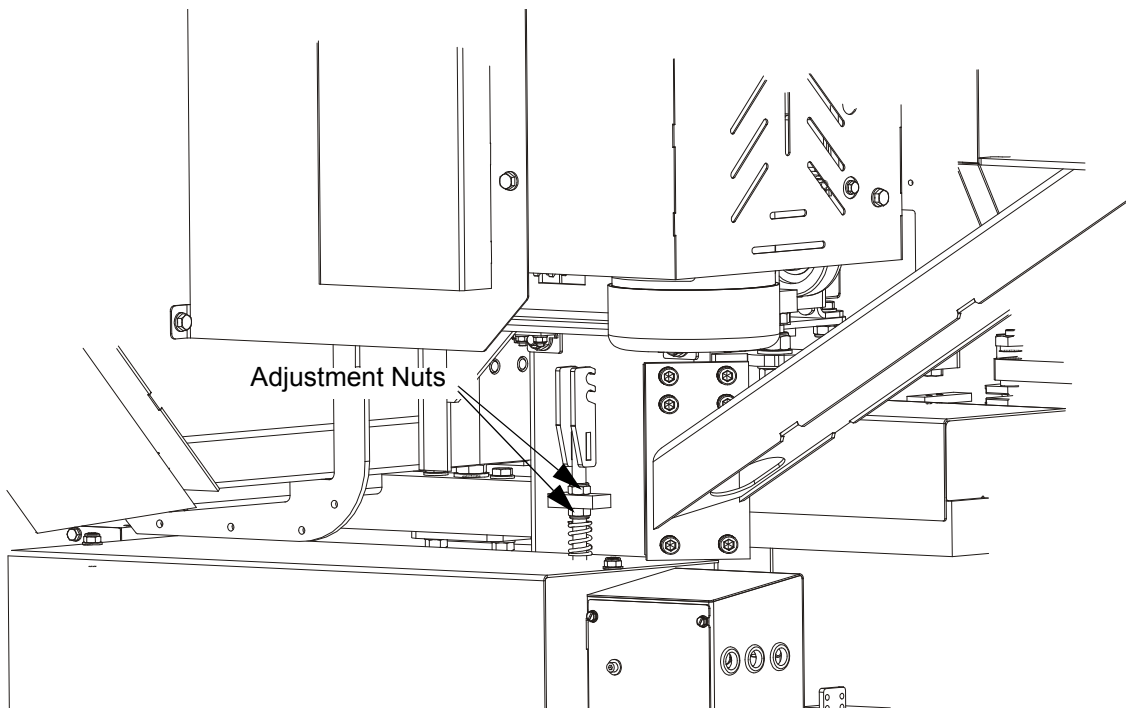

FIG. 3-4

1. Adjust the motor belt tension as needed. To do this, loosen the motor mounting bolts and turn adjustment bolts clockwise or counterclockwise evenly, until the belt is properly tensioned. Tighten the motor mounting bolts.

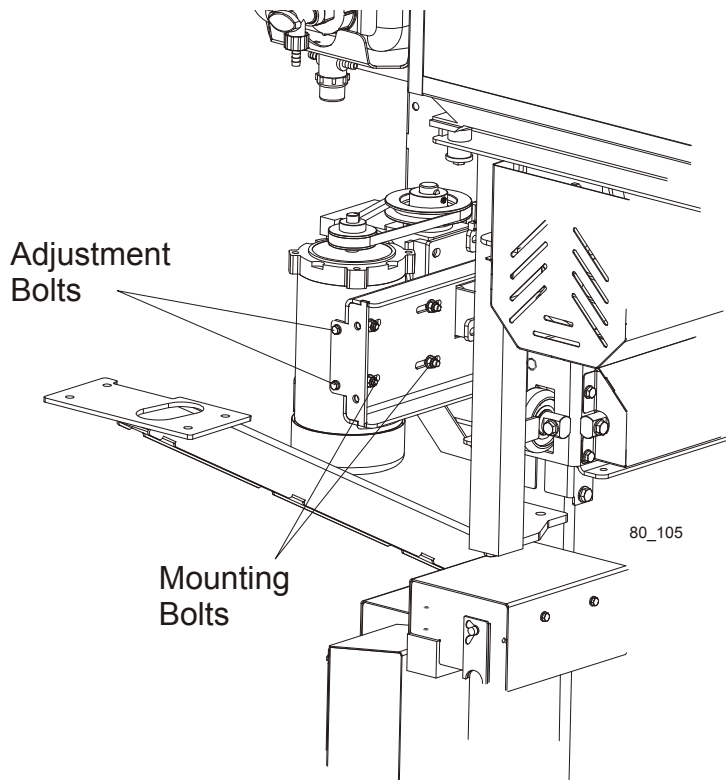

FIG. 3-4

AR

Periodically check the belt for wear. Replace any damaged or worn belts as needed.

2. When oil leaks from the gear reducer please contact Customer Service.

3.10 Power Feed

1. Adjust the power feed chain as needed. Measure the power feed chain tension with the saw head all the way toward the front of the mill. Use the two lock nuts to tighten or loosen the power feed chain. Adjust the chain until it measures 7 to 8 inches (17.8 to 20.3 cm) from the top of the top rail at its lowest point.



CAUTION! Do not overtighten the feed chain. Damage to the power feed motor may result.

See Figure 3-5.

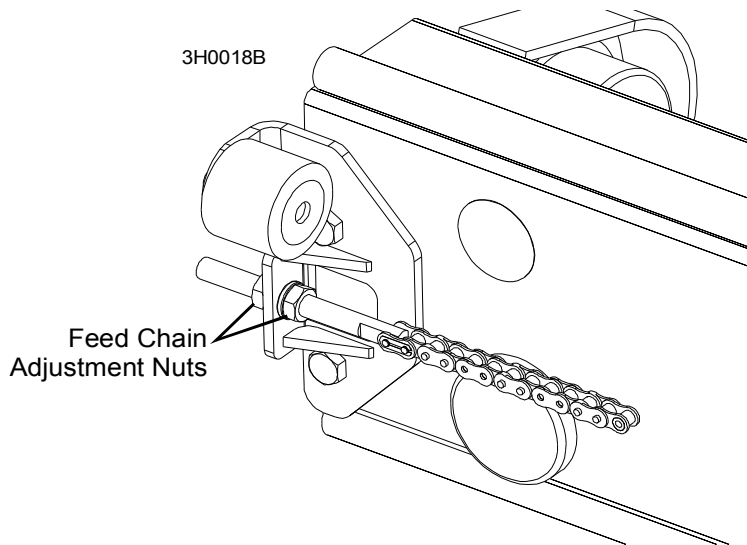

FIG. 3-5

3.11 Hydraulic System

1. Check the hydraulic fluid level every fifty hours of operation. Add fluid as necessary. The level in the hydraulic pump should be 3/4" (19mm) from the top with all cylinders collapsed.

If humidity is a problem or the mill is used outside in humid weather, drain and replace two quarts (.95 liters) of fluid every six months. This will drain any accumulated water and help prevent pump failure due to water ingestion. It also will prevent excessive fluid wear and allow the fluid to maintain its hot end performance. If humidity is not a problem, drain and replace one gallon (3.8 liters) of fluid every year to prevent fluid wear.

1. If you are operating in temperatures -20° to 100° F (-29° to 38° C), use an all-weather hydraulic fluid such as Exxon Unavis J26. For alternate fluids and/or other temperature ranges, refer to the chart below. Operating above the recommended temperature range of a fluid could result in excessive pump wear. Operating below the recommended temperature range could result in reduced hydraulic cylinder speed. To change fluid types, replace one gallon of the current fluid with one gallon of the alternate fluid.

TEMPERATURE

F -30° -20° -10° 0° 10° 20° 30° 40° 50° 60° 70° 80° 90° 100° 110° 120°

C -35° -29° -23° -18° -12° -7° -1° 5° 10° 16° 21° 27° 32° 38° 44° 49°

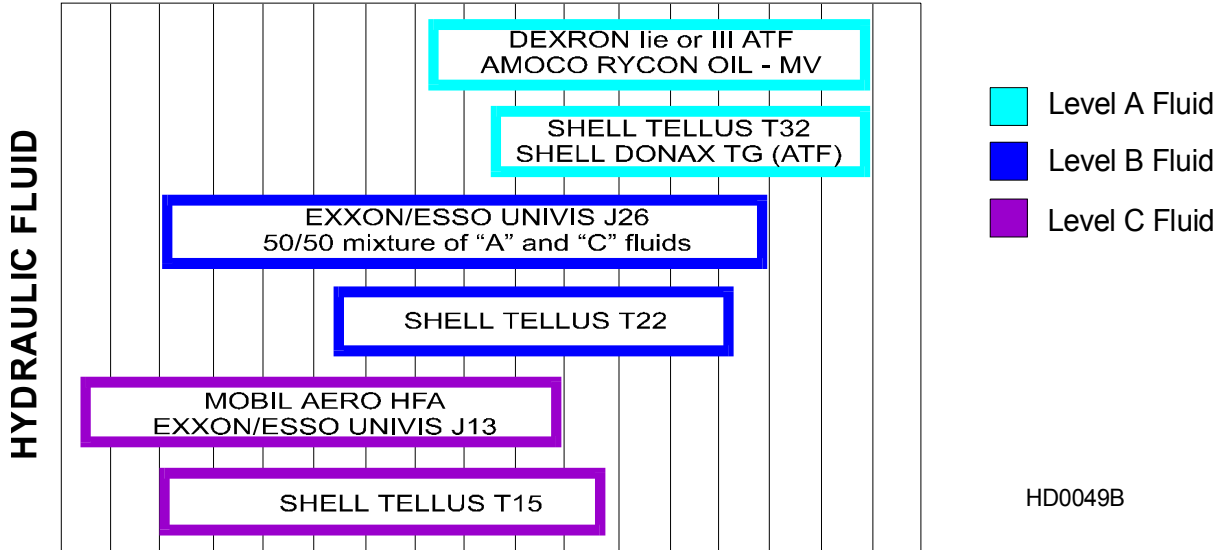

FIG. 3-6

500

Replace the hydraulic system cartridge filter every 500 hours of operation. Inspect the hydraulic pump motor brushes every 750 hours of operation. Remove brush dust and replace the brushes if they worn to a length of 1/4" or shorter. Do not operate the hydraulic system if the pump motor brushes are worn shorter than 1/4". Damage to the pump motor may result

2. Periodically check all hydraulic lines and fitting as needed. Replace as necessary.

3.12 Safety Devices Inspection

LT70 AC – Safety Devices Inspection

Safety devices on the LT70AC machine which must be checked before every shift:

- E-STOP button and its circuit inspection
- Inspection of the control circuits with the E-STOP button pressed
- Blade cover safety switch #1 and its circuit inspection
- Blade cover safety switch #2 and its circuit inspection
- Motor brake and its circuit inspection

1. E-STOP button and its circuit inspection

- Turn on the blade motor;
- Press the E-STOP button located on the left side of the control box. The blade motor should be stopped. Pressing the START button should not start the motor until the E-STOP button is released.

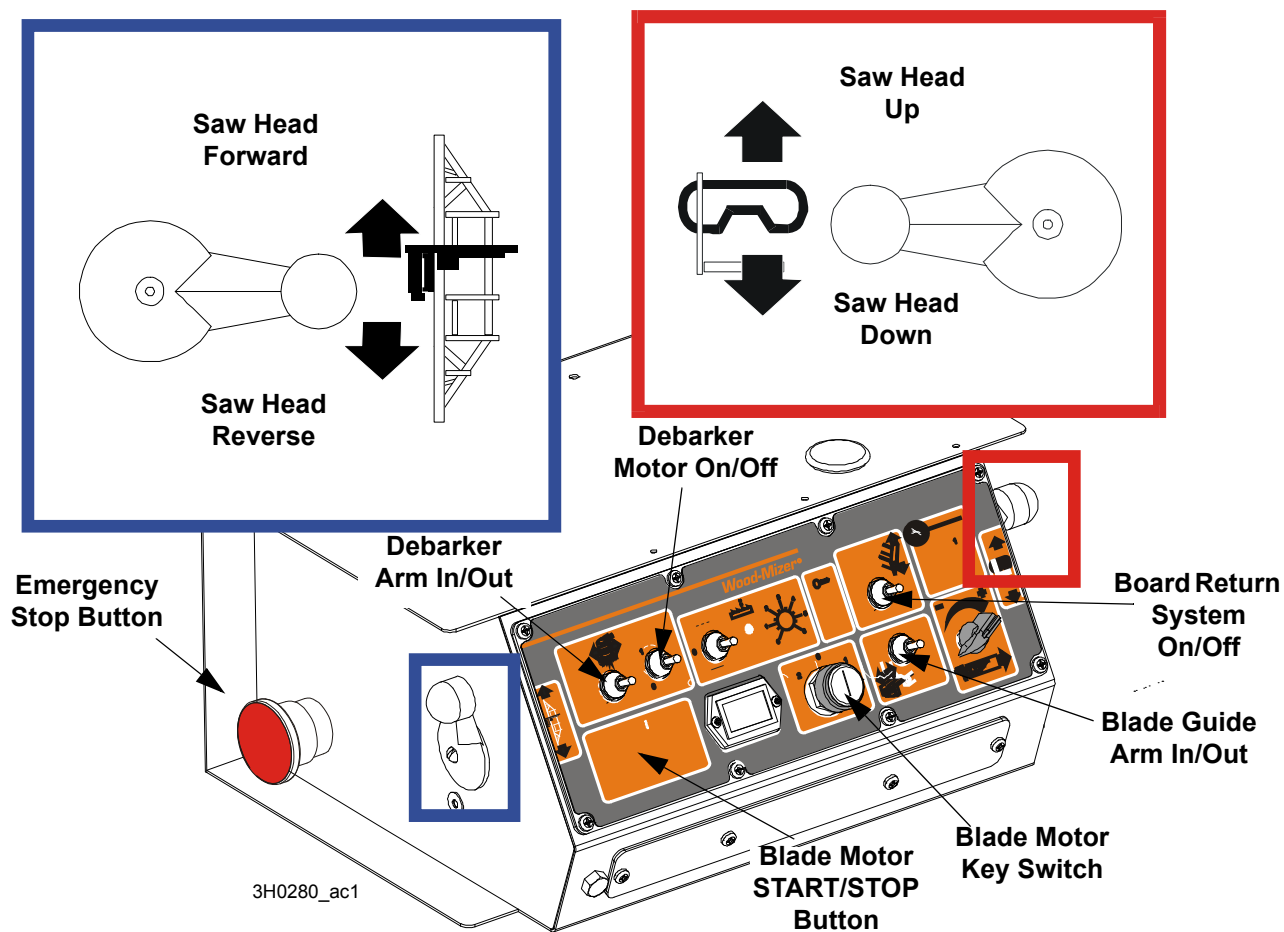

2. Inspection of the control circuits with the E-STOP button pressed

- Turn on the blade motor;
- Press the E-STOP button located on the left side of the control box. The blade motor should be stopped.
- With E-STOP button pressed, try to move the saw head up and down using the switch and the Setworks buttons and forward/backward using the power feed switch. Both systems should not start.
- With E-STOP button pressed, try to start the debarker blade motor and move the debarker arm in and out. The debarker should not work.
- With E-STOP button pressed, try to move the blade guide arm in and out. The blade guide arm should not work.
- With E-STOP button pressed, try to start the board return system. The board return system should not work.

3. Blade cover safety switch #1 and its circuit inspection.

- Turn on the blade motor;
- Open the blade housing cover #1;

- The blade motor should be stopped;
- Try to start the motor. The blade motor should remain stopped;
- Close the blade housing cover #1;
- The blade motor should remain stopped until it is restarted with the START button.

4. Blade cover safety switch #2 and its circuit inspection.

- Turn on the blade motor;
- Open the blade housing cover #2;
- The blade motor should be stopped;
- Try to start the motor. The blade motor should remain stopped;
- Close the blade housing cover #2;
- The blade motor should remain stopped until it is restarted with the START button.

5. Motor brake and its circuit inspection

- Turn on the blade motor. Stop the motor using the STOP button. Measure the braking time.
- Turn on the blade motor. Stop the motor by switching the key to the "0" position. Measure the braking time.
- Turn on the blade motor. Stop the motor by switching the key to the "2" position. Measure the braking time.
- The braking time should always be shorter than 10 seconds. If the braking time is longer, it is necessary to adjust or replace the motor disk brake. See your motor option manual.

SECTION 4 TROUBLESHOOTING

4.1 Sawing Problems

PROBLEM	CAUSE	SOLUTION
Blades Dull Quickly	Dirty logs	Clean or debark logs, especially on entry side of the cut
	When grinding teeth, heating too much and causing teeth to soften	Grind just enough metal to restore sharpness to the teeth. Use water/coolant while sharpening blade
	Poor sharpening techniques	Make sure the tip is being sharpened completely (See Sharpener Manual)
Blades Break Prematurely	Rubber belts on blade wheels worn to a point that blade contacts metal pulley - look for shiny spots on edge of wheels	Change blade wheel belts (B-57)
	Poor sharpening techniques	See Sharpener Manual
	Tension too tight	Tension blade to recommended specifications
Blade Does Not Track Right on Drive Wheel	Cant adjustment is incorrect	Readjust
	Flat/worn belts	Replace B-57 belts
Blade Guides Do Not Spin While Cutting	Frozen bearings	Replace bearings
	Stiff bearings	Grease bearings
Drive Belts Wear Prematurely or Jump	Engine/motor and drive pulleys out of alignment	Align drive pulleys See Section 4.5 Engine/Motor Drive Pulleys Alignment.

PROBLEM	CAUSE	SOLUTION
Boards Thick Or Thin On Ends Or Middle Of Board.	Stress in log which causes log to not lay flat on the bed.	After log has been squared, take equal cuts off opposing sides. Take a board off the top. Turn the log 180 degrees.. Take a board off. Repeat, keeping the heart in the middle of the cant, and making it your last cut.
	Set in teeth.	Resharpener and reset blade.
	Bed rails misaligned.	Realign sawmill.
Height Adjustment Jumps or Stutters When Moving Up or Down.	Mast needs lubrication.	Lubricate mast track surface
	Up/down chain improperly adjusted.	Adjust up/down chain.
	Drive belt(s) loose.	Adjust drive belt(s)
Lumber Is Not Square	Vertical side supports not square to bed	Adjust side supports.
	Blade not parallel to bed rails	Adjust bed rails parallel to blade.
	Sawdust or bark between cant and bed rails	Remove particles
Sawdust Builds Up On Track	Tooth set problem	Resharpener and reset blade.
	Excessive oiling	Do not oil track
	Track wipers worn	Adjust wipers to firmly contact track
	Track is sticky	Clean track with solvent and apply silicone spray
Wavy Cuts	Excessive feed	Slow feed rate
	Improperly sharpened blade (This will be the problem 99% of the time!)	Resharpener blade (See Sharpener Manual - read entire manual!)
	Blade guides improperly adjusted	Adjust blade guides.
	Sap buildup on blade	Use Water Lube.
	Tooth set problem	Resharpener and reset blade.

4.2 Electrical Problems

PROBLEM	CAUSE	SOLUTION
Up/down Excessively Slow.	Up/down rollers stuck.	Adjust rollers.
	Up/down belt loose.	Adjust belt to be as loose as possible without slipping
	Thermal overload tripped	Reset.
Up/down Or Power Feed Motors Do Not Work.	Worn/dirty contacts in drum switch.	Replace switch or remove control panel cover and clean contacts.
	Bad key switch.	Replace key switch.
	Circuit breaker.	Reset breaker in control box (See Section 4.11).
	Burned-out motor.	Replace motor
Power Feed Motor Does Not Work.	Sawdust buildup in the power feed pulleys.	Sawdust buildup puts mechanical bind on power feed which causes thermal overload. Remove sawdust from pulleys and operate normally. Reset overload and operate normally.
Up/Down Or Power Feed Switches Remain Engaged When Switch Is Released.	Worn or dirty contacts in drum switch.	Manually move the power feed or up/down switch back to neutral position. Replace drum switch or remove control panel cover and clean and lubricate contacts NOTE: NOTE: Use only contact grease supplied by Wood-Mizer.
	Drum switch spring broken	Manually move the power feed or up/down switch back to neutral or "off" position. Replace drum switch spring.
Up/Down Or Power Feed Motors Overheat And Loose Power.	System overload or bind occurred.	Correct problem. See Section 4.3 Power Feed Problems . Allow motor to cool before restarting.
	Normal operation factors exceeded (eg: up/down control jockeyed excessively).	Allow motor to cool before restarting.

4.3 Power Feed Problems

problem	CAUSE	SOLUTION
Power Feed Is Jerky At Low Speeds Or Does Not Move Until Speed Is Above Halfway Mark	Drum switch is dirty	Clean drum switch and lubricate with grease supplied by Wood-Mizer.
	Worn drum switch contacts	Check that contacts are in good condition and positively close circuit.
	Components are loose or wires are broken.	Replace or repair PC board.
Power Feed Is Jerky When Shaft Of Feed Rate Dial Is Moved Back And Forth.	Variable speed switch is bad - perform the variable speed switch test.	Replace variable speed switch.
Power Feed Is Jerky, But Power Feed Motor Runs Properly At All Speeds.	Problem is mechanical.	Refer to the Mechanical Test.
Power Feed Is Sluggish, Trips Circuit Breaker Or Current Limit.	Sawdust buildup in power feed cover.	Remove power feed belt cover and remove sawdust.

4 Troubleshooting

Power Feed Problems

problem	CAUSE	solution
Power Feed Motor Overheats.	Middle track oiler is dragging.	Clean middle track oiler and lubricate. Allow motor to cool before restarting.
	Ground is not level.	Level mill with carpenter's level. Allow motor to cool before restarting
	Track roller bearing drag is excessive.	Lubricate bearings; Replace tight bearings. Allow motor to cool before restarting
	Lower track rollers are not aligned properly.	Check stop block clearance from lower track rail. Allow motor to cool before restarting
	Chain is dragging.	Make sure chain is centered on cam follower bearing; Clean and lubricate chain; Adjust chain tension. Allow motor to cool before restarting
	Chain is improperly tensioned.	Adjust chain tension. Allow motor to cool before restarting.
	Seat load is excessive.	Check seat bearings for freedom of movement; Loosen clamping screw 1/4 turn. Allow motor to cool before restarting
	Power feed is binding.	Adjust belt tension; Check condition of belt, pulleys, bearings, and sprocket; Check motor for ground fault. Allow motor to cool before restarting
	Saw head load is excessive.	Avoid unnecessary modifications to saw heads that would give them extra weight. Allow motor to cool before restarting.
	Blade is dull or improperly set.	Use proper blade maintenance procedures (See Sharpener or Toothsetter manual). Allow motor to cool before restarting

4.4 Hydraulic Problems

PROBLEM	CAUSE	SOLUTION
You Can Actuate Any Hydraulic Handle, But Get No Response From The Pump.	Carriage not positioned properly to provide drive signal to the hydraulic control	Make sure carriage contact bracket is adjusted far enough forward for battery positive contact to touch strip on main tube. Check contact and strip for tarnish or loose wires. Clean as necessary
	Poor ground connection.	Check negative contact and lower rail. Check contact and rail for tarnish or loose wires. Clean as necessary.
	Circuit breaker tripped	Reset breaker.
	Defective pump motor	Replace
	Poor cable connection	Check cable connection.
You Can Get Response From the Pump By Actuating All But One or Two Handles	Defective motor pump contactor	Replace
	Valve assembly switch contacts are not properly adjusted	<p>Locate the valve switch at the bottom of the valve assembly. Use a 3MM allen wrench to loosen the set screw on each of the five switch contacts. Press each contact to the valve block and tighten the contact set screw to secure in place. CAUTION! Do not overtighten!</p> <p>NOTE: Do not adjust the valve switch or switch spring; they have been preset at the factory.</p>

4 Troubleshooting

Hydraulic Problems

PROBLEM	CAUSE	SOLUTION
	Low fluid level	Check fluid level. Add an all-season hydraulic fluid such as Amoco Rycon Oil MV or Mobil Multipurpose ATF (automatic transmission fluid) until level is 4 - 4 1/2" from bottom of reservoir with all cylinders retracted
	Pressure relief valve moved from proper setting	Adjust pressure relief valve.
	Low air temperature causing oil to thicken	Allow fluid to warm up. Synthetic fluids are available that allow for hydraulic operation in cold weather conditions (Exxon/Esso Univis J26).
Pump Motor Runs Continuously When Power Contact Is Made	Solenoid is stuck closed	Tapping the solenoid may solve this problem temporarily. Replace solenoid.
Fluid Leaks From Around Cylinder Piston Ram	Worn seals	Replace seals in cylinder. Check piston ram for abrasive weld that may be causing premature seal failure
Fluid Leak Around Pump Box	Loose seal or fitting	Wipe pump off completely to locate cause of leak. You may have to unbolt the pump to wipe behind it. NOTE: Movement of the sawmill can cause fluid to slosh up into the foam filter in the reservoir cap, and subsequently spray out, giving the appearance that fluid is leaking from the pump

PROBLEM	CAUSE	SOLUTION
Hydraulic Side Supports Go Down Before Or At Same Time As Log Turner	Dirt in sequence valve	Remove sequence valves and clean thoroughly with kerosene. NOTE: Be sure to reassemble the valve and install it in its original position on the cylinder
	Retainer in sequence valve worn	Replace sequence valve
	Low air temperature causing oil to thicken	Allow fluid to warm up. Synthetic fluids are available that allow for hydraulic operation in cold weather conditions (Exxon/Esso Univis J26).
Hydraulic Turner Goes Up Before Or At Same Time As Side Supports	Spring weakening in sequence valve	Locate sequence valve at top of turner cylinder. Turn heavy spring in about 1/4 turn
	Dirt in sequence valve	Remove sequence valves and clean thoroughly with kerosene. NOTE: Be sure to reassemble the valve and install it in its original position on the cylinder
	Retainer in sequence valve worn	Replace sequence valve
	Low air temperature causing oil to thicken	Allow fluid to warm up. Synthetic fluids are available that allow for hydraulic operation in cold weather conditions (Exxon/Esso Univis J26).
	Spring weakening in sequence valve	Locate sequence valve at bottom of turner cylinder. Turn heavy spring in about 1/4 turn

4.5 Engine/Motor Drive Pulleys Alignment

1. Install the drive belt..
2. Use a straight edge to align the engine/motor pulley to the drive pulley. Also check that the engine pulley is linear with the drive pulley. Loosen the engine mounting bolts and rotate the engine if necessary..
3. Check front-to-back movement of the engine does not exceed 1/4". Tighten the motor mount U-bolts if necessary..
4. Engage the clutch handle and adjust the drive belt tension to 7/16" deflection with 10 lb. of force.
5. Recheck the pulley alignment and engine squareness with the clutch handle engaged. Adjust if necessary.
6. Adjust the drive belt support to 1/4" ($\pm 1/32$) from the belt while engaged.

4.6 Power Feed Variable Speed Switch Test

With the feed rate dial switch all the way down, move the shaft of the dial back and forth to see if there is a jerky response. Turn the dial and move the shaft back and forth again. Repeat several times. If the jerkiness occurs at the same location on the dial several times, you need to replace the variable speed switch.

4.7 Power Feed Preliminary Test

This test will determine if the problem is a mechanical or electrical.

1. Remove the drive belt from the power feed drive pulley..
2. Turn the key switch to the ACC position. Put the carriage forward/reverse switch into the forward position and turn the feed rate dial through all speeds. If the power feed motor runs properly at all speeds, the problem is a mechanical one instead of an electrical one.

4.8 Power Feed Mechanical Test

1. Remove the weight from the track rollers. They should turn smoothly and easily with very little play.
2. Make sure the middle track cover is not bent or touching the top rail.
3. Make sure the middle track oiler is free of sawdust buildup.
4. Make sure the power feed chain is not stiff from rust. Also make sure the chain is not too tight.
5. Make sure the power feed chain cam bearing is not touching the main frame tube.
6. Make sure there is no sap or rust on the rails.

7. Make sure the block on the lower track roller assembly is not rubbing the lower rail. Also make sure the track rollers are not too tight.
8. Make sure the power feed belt is properly tightened.

4.9 Circuit Breaker Operation

Sawmill controls are equipped with manual reset circuit breakers to protect the electrical circuits.

See Figure 4-1. The blade guide and accessory, breakers are located inside the control box. Remove the circuit breaker panel from the control box to access the internal breakers.

NOTE: If the breaker is still hot, you may not be able to reset it immediately. Allow the breaker to cool for a few minutes before attempting to reset.

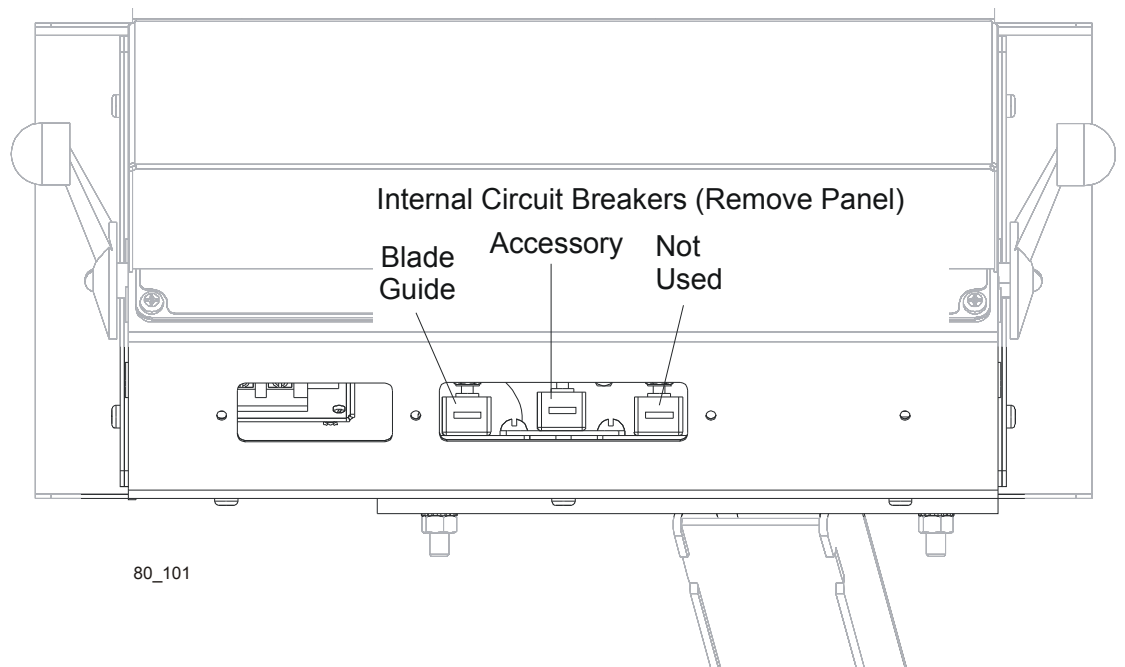

FIG. 4-1

SECTION 5 SAWMILL ALIGNMENT

The Wood-Mizer sawmill is factory aligned. Two alignment procedures are available to realign the sawmill if necessary. The Routine Alignment instructions should be performed as necessary to solve sawing problems not related to blade performance. The Complete Alignment procedure should be performed approximately every 1500 hours of operation (sooner if you regularly transport the sawmill over rough terrain).

5.1 Routine Alignment Procedure:

Blade Installation

1. Remove the blade and check the blade wheels. Remove any sawdust buildup from the surface of the wheels.
2. Install a clean blade and apply the appropriate tension. ([See Section 2.5](#)).
3. Check the blade guide inserts are properly adjusted ([See Section 3.2](#)).
4. Adjust the idle-side cant control to track the blade ([See Section 2.6](#)).
5. Raise the middle blade housing cover and make sure all persons are clear of the open side of the saw head.
6. Turn the key switch to #2 position.
7. Turn the key switch to #3 position. Manually spin one of the blade wheels until the blade positions itself on the blade wheels.

Saw Head Tilt

As the blade enters a wide log or cant, the outside of the saw head will drop down slightly. To compensate for the drop, the saw head is adjusted $1/26"$ (1 mm) higher at the outside.

1. Move the saw carriage so the blade is positioned over a bed rail. Adjust the blade guide arm to $1/2"$ (15 mm) from full open.
2. Raise the saw head so the bottom of the blade measures $14\ 3/4"$ (375 mm) from the top surface of the bed rail near the inner blade guide assembly.

See Figure 5-1.

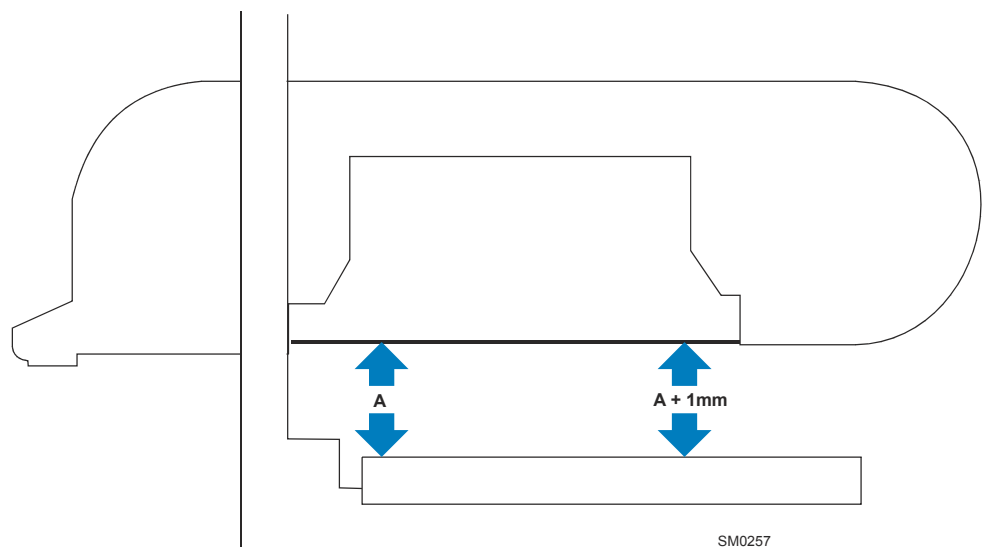

FIG. 5-1

3. Measure from the blade to the bed rail near the outer blade guide assembly. This measurement should be $1/26"$ (1 mm) higher than the inner measurement or $14\ 13/16"$ (376mm).

5

Sawmill Alignment

Routine Alignment Procedure:

See Figure 5-2. To adjust the saw head tilt, use the bolts located at the bottom of the saw head mast. Loosen the three sets of four retaining plate bolts. To raise the outside of the saw head, back the stop bolts out, then tighten the adjustment bolts. To lower the outside of the saw head, loosen the adjustment bolts and tighten the stop bolts. Recheck the measurement from the blade to the bed rails and adjust the stop bolts and adjustment bolts until the outside of the saw head is 1/26" (1mm) higher than the inside. Retighten the retaining plate bolts..

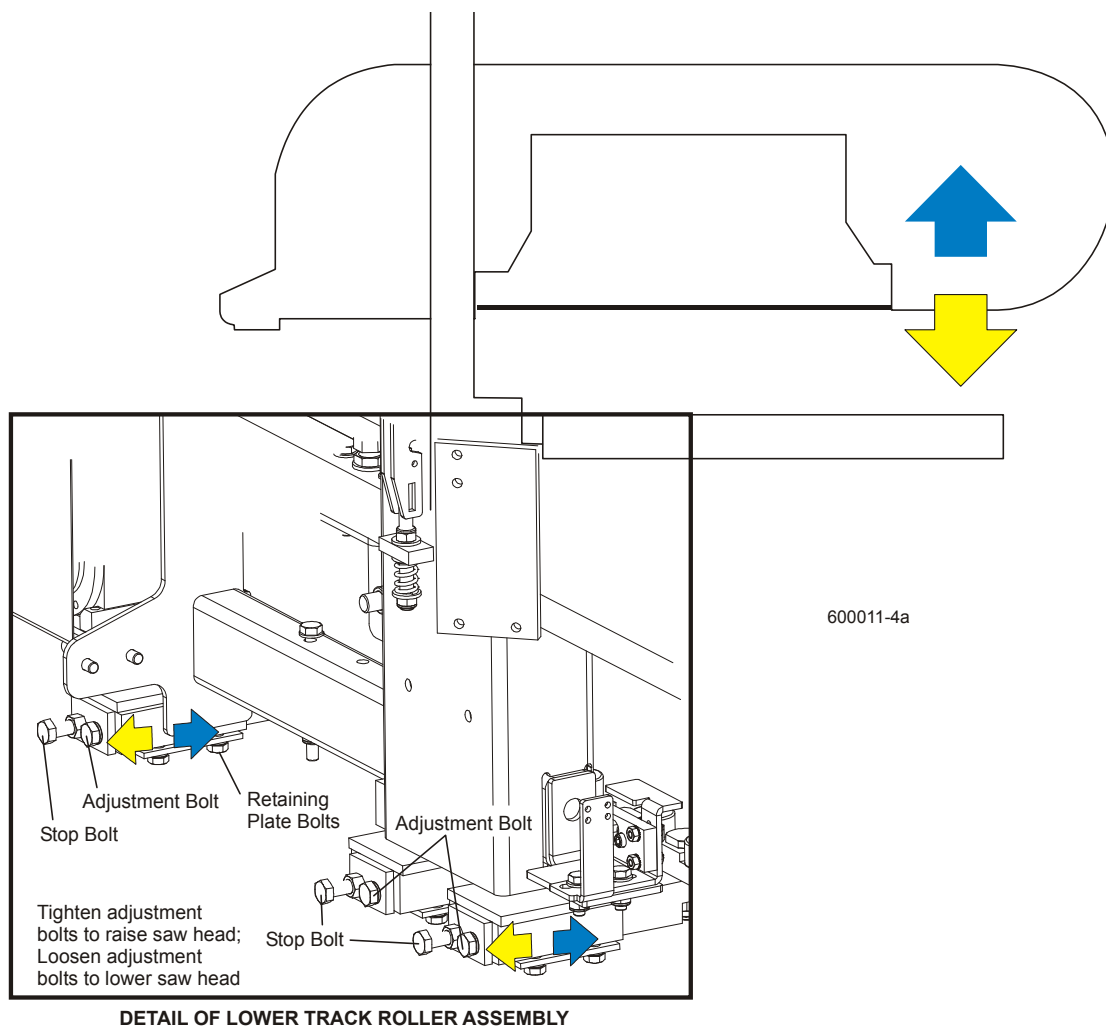

FIG. 5-2

Blade Guide Arm Alignment

The blade guide arm moves the outer blade guide in and out. If the arm becomes loose, the blade guide will not guide the blade properly, causing inaccurate cuts. A loose blade guide arm can also cause blade vibration.

1. Adjust the blade guide arm in to 1/2" (15 mm) from fully closed.
2. Manually try to move the arm up and down. If you can move the arm by hand, you will need to tighten the arm rollers.

See Figure 5-3. Loosen the jam nuts and turn the adjustment bolts in to tighten the blade guide arm rollers. Retighten the jam nuts.

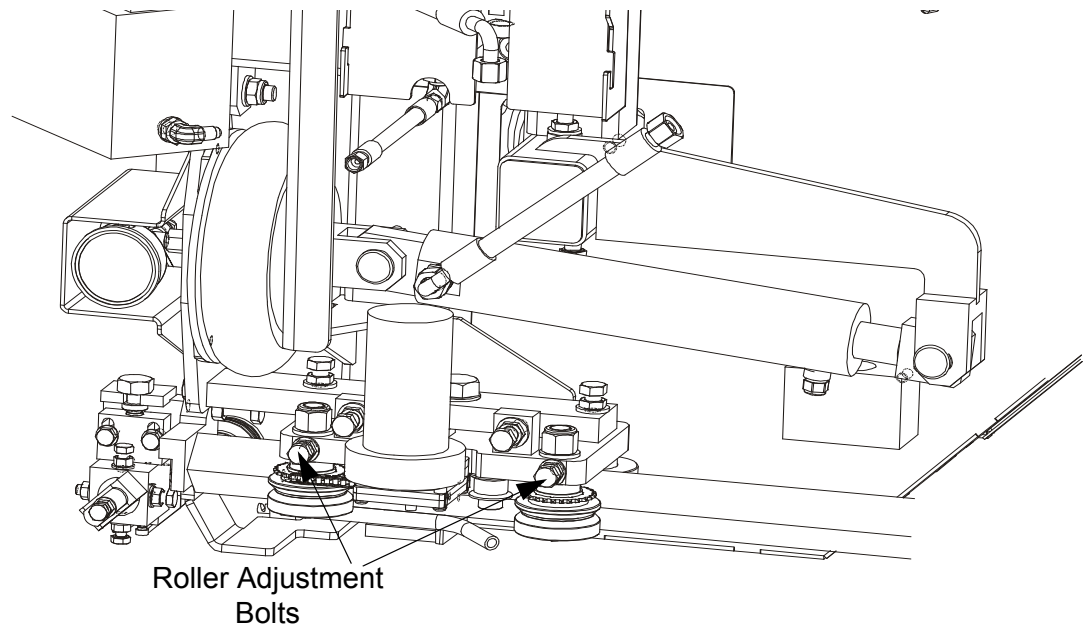

FIG. 5-3

5

Sawmill Alignment

Routine Alignment Procedure:

After tightening the blade guide arm rollers, check that the arm is aligned properly.

Blade Guides

3. With the arm adjusted 1/2" (15 mm) from fully closed, measure the distance between the blade guide roller flange and the back of the blade. If the sawmill is equipped with optional all-ceramic guides, measure from the back of the blade to the back roller.

See Figure 5-4.

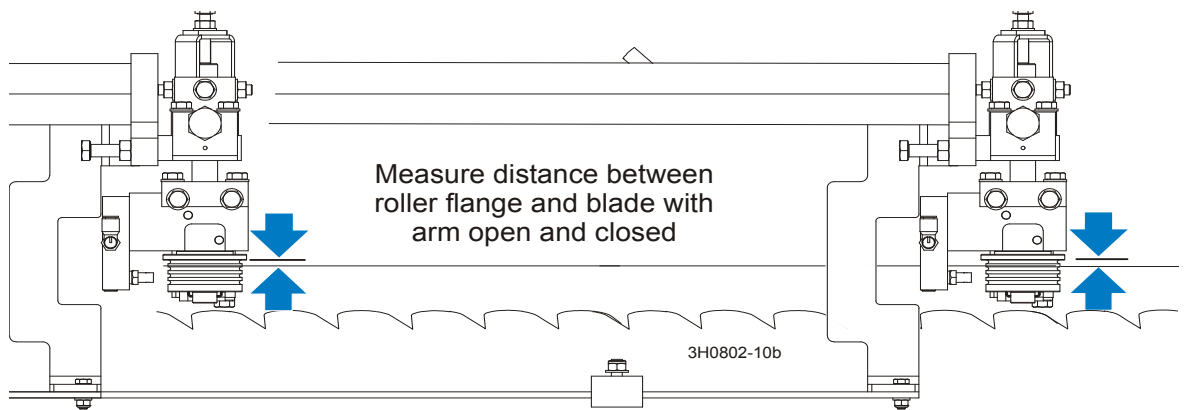

FIG. 5-4

4. Adjust the blade guide arm to 1/2" (15 mm) from fully open and remeasure the distance from the roller flange to the back of the blade. The two measurements should be the same. If not, adjust the outer rollers in or out to tilt the arm horizontally.

See Figure 5-5. Loosen the horizontal adjustment bolt jam nuts. To tilt the arm in toward the blade, loosen the right bolt and tighten the left bolt. To tilt the arm out away from the blade, loosen the left bolt and tighten the right bolt. Retighten the jam nuts and recheck the blade guide arm horizontal tilt.

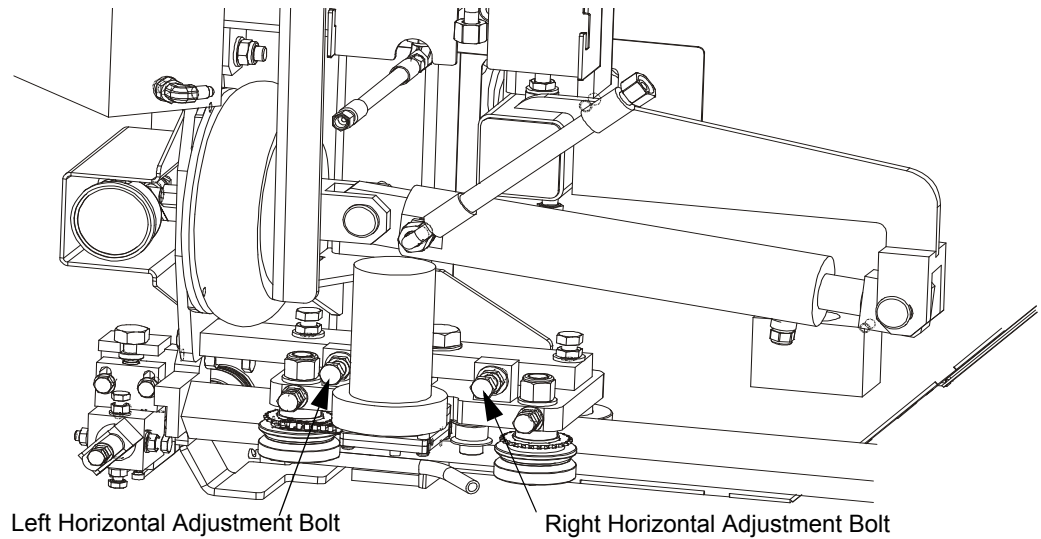

FIG. 5-5

5. Now check the vertical tilt of the blade guide arm. Move the saw carriage so the blade guide arm is positioned over a bed rail.
6. With the arm 1/2" (15 mm) from fully closed, raise or lower the saw head until the bottom of the blade guide block is 15" (375 mm) from the top of the bed rail.

See Figure 5-6.

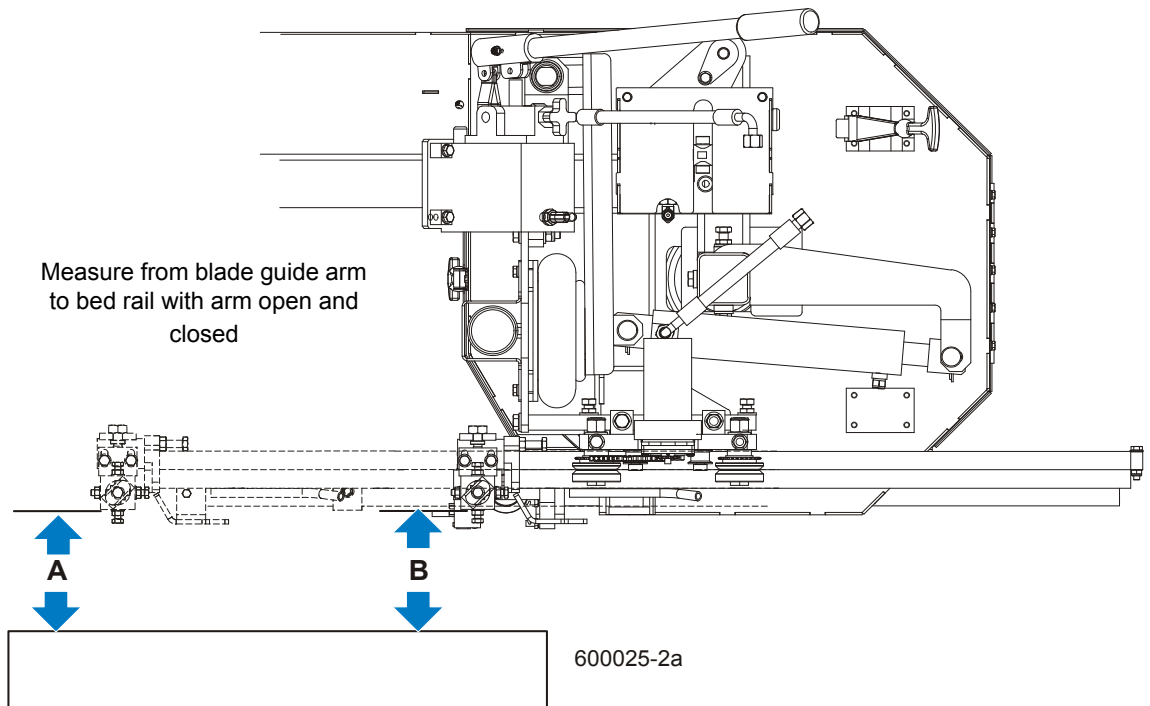

FIG. 5-6

7. Adjust the blade guide arm to 1/2" (15 mm) from fully open. Measure the distance from the bottom of the blade guide mounting block to the bed rail. This measurement should be 15" (375 mm) or slightly higher because the saw head is tilted up 1/26" (1 mm) on the outside ([See Saw Head Tilt](#)). If the blade guide is closer to the bed rail or more than 1/26" (1mm) higher with the arm open, adjust the blade guide arm vertically.

See Figure 5-7. Loosen the vertical adjustment bolt jam nuts. To tilt the blade guide arm down, loosen the right bolt and tighten the left bolt. To tilt the blade guide arm up, loosen the left bolt and tighten the right bolt. Retighten the jam nuts and recheck the blade guide arm vertical tilt..

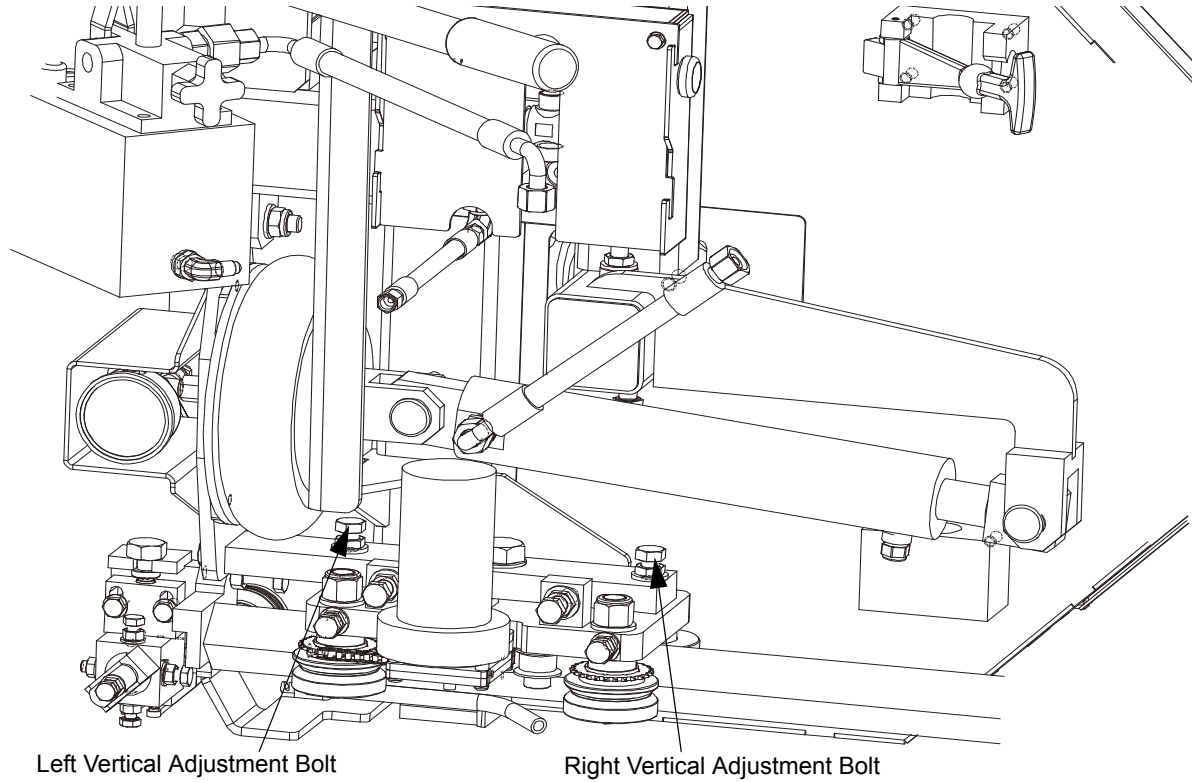

FIG. 5-7

Blade Guide Vertical Tilt Alignment

The blade guides should be adjusted properly in the vertical plane. If the blade guides are tilted vertically, the blade will try to travel in the tilted direction.

A Blade Guide Alignment Tool (BGAT) is provided to help you measure the vertical tilt of the blade..

1. Open the adjustable blade guide arm 1/2" (15 mm) from full open.
2. Clip the alignment tool on the blade. Position the tool close to the outer blade guide assembly. Be sure the tool does not rest on a tooth or burr, and is lying flat against the bottom of the blade.

See Figure 5-8.

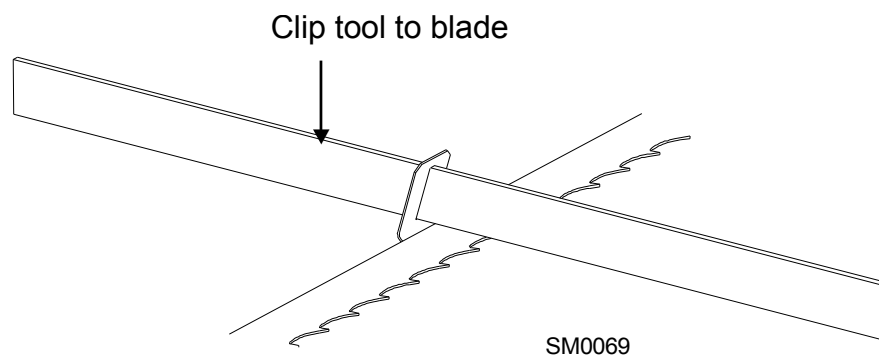

FIG. 5-8

3. Move the carriage so that the front end of the tool is positioned above the bed rail. Measure the distance from the bed rail to the bottom edge of the tool.
4. Move the carriage so that the back end of the tool is positioned above the bed rail. Measure the distance from the bed rail to the bottom edge of the tool.
5. If the measurement from the tool to the bed rail is not equal within 1/26" (1mm), adjust the vertical tilt of the outer blade guide roller.

See Figure 5-9. Loosen the jam nuts on the top and bottom vertical tilt adjustment screws.. To tilt the roller up, loosen the bottom screw and tighten top screw. To tilt the roller down, loosen the top screw and tighten

the bottom screw. Tighten the jam nuts and recheck the tilt of the blade..

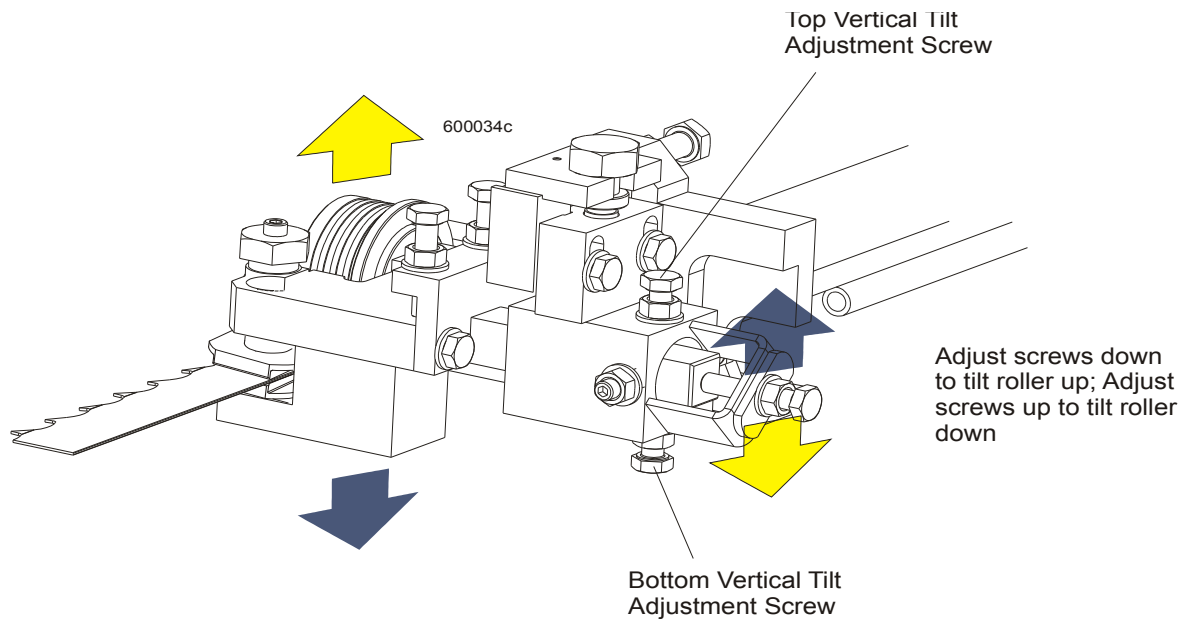

FIG. 5-9

6. Move the blade guide alignment tool close to the inner blade guide roller assembly and repeat the above steps. Adjust the vertical tilt of the inner blade guide if necessary.

Blade Guide Horizontal Tilt Adjustment

If the blade guides are tilted in the wrong direction horizontally, the back of the blade may contact the flange as the roller is spinning down, causing it to push the blade away from the guide roller.

1. Remove the blade guide alignment tool from the blade and adjust the blade guide arm halfway in.
2. Remove the clip from the blade guide alignment tool. Place the tool against the face of the outer blade guide roller.

See Figure 5-10.

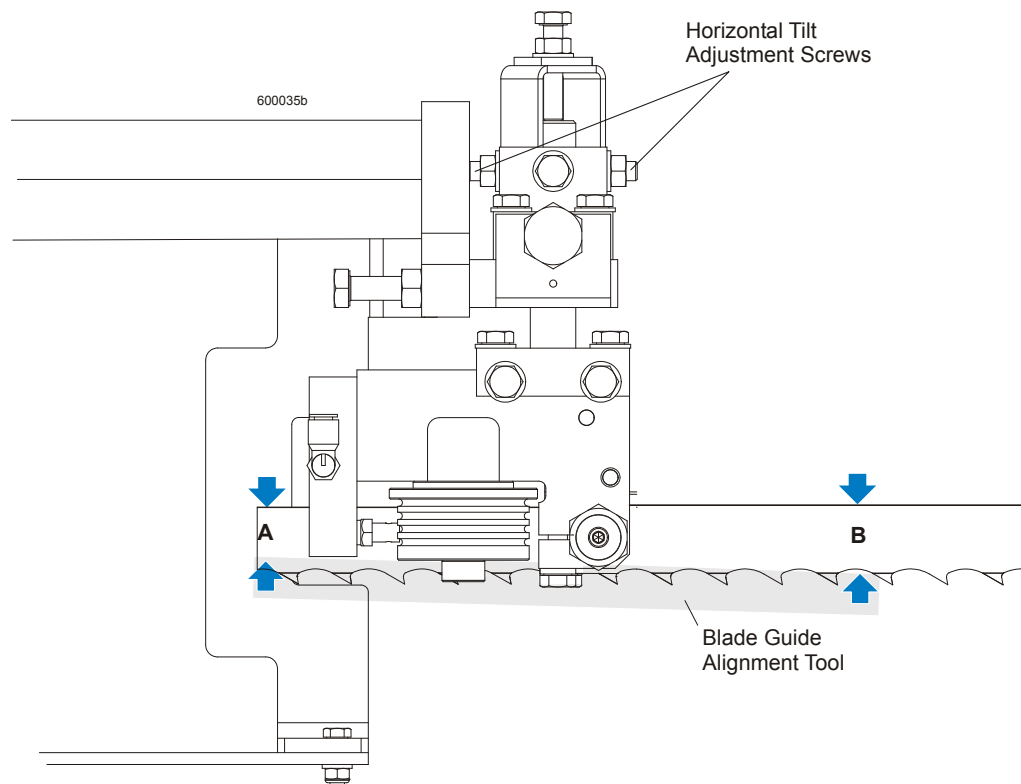

FIG. 5-10

3. Measure between the back edge of the blade and the tool at the end closest to the inner blade guide ("B").
4. Measure between the back edge of the blade and the other end of the tool ("A").

he roller should be tilted slightly to the left ('A' 1/8" [3 mm] less than 'B' $\pm 1/8$ " [3 mm]).

See Figure 5-11. Loosen the jam nuts on the horizontal tilt adjustment screws. To tilt the roller left, loosen the right screw and tighten left screw. To tilt the roller right, loosen the left screw and tighten the right screw.

Tighten the jam nuts and recheck the tilt of the blade.

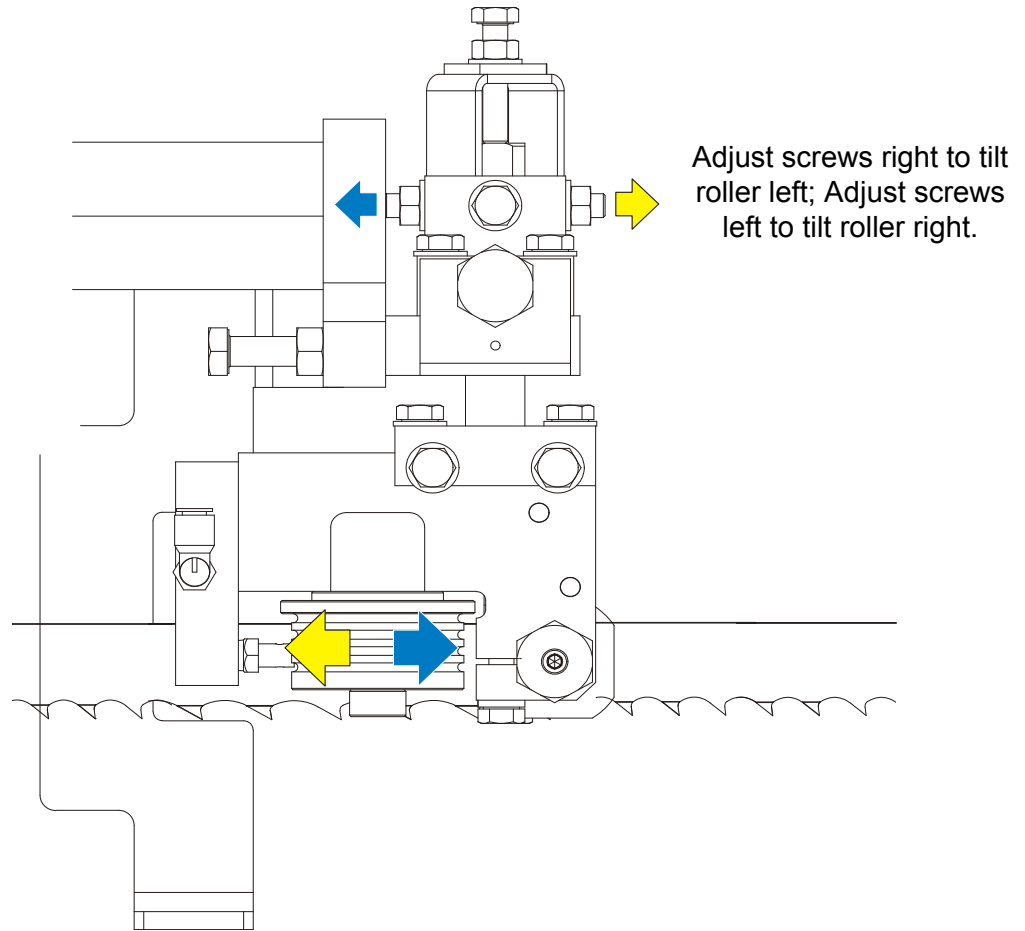

FIG. 5-11

5. Repeat the above steps for the inner blade guide roller assembly.

NOTE: Once the blade guides have been adjusted, any cutting variances are most likely caused by the blade. [See the Blade Handbook, Form #600.](#)

Blade Guide Flange Spacing.

Each blade guide must be adjusted so the roller flange is the correct distance from the back edge of the blade. If the flange is too close to or too far from the blade, the sawmill will not cut accurately.

HINT: When adjusting blade guide spacing, loosen the top set screw and one side set screw only. This will ensure horizontal and vertical tilt adjustments are maintained when the adjustment screws are retightened.

1. Measure the distance between the flange on the inner blade guide roller to the back edge of the blade. This distance should measure 1/16" (1.5 mm). Adjust the roller back or forward if necessary.

See Figure 5-12. Loosen the top and one side screw shown and rear adjusting bolt if necessary. Tap the blade guide forward or backward until properly positioned. Retighten the screws and jam nuts.

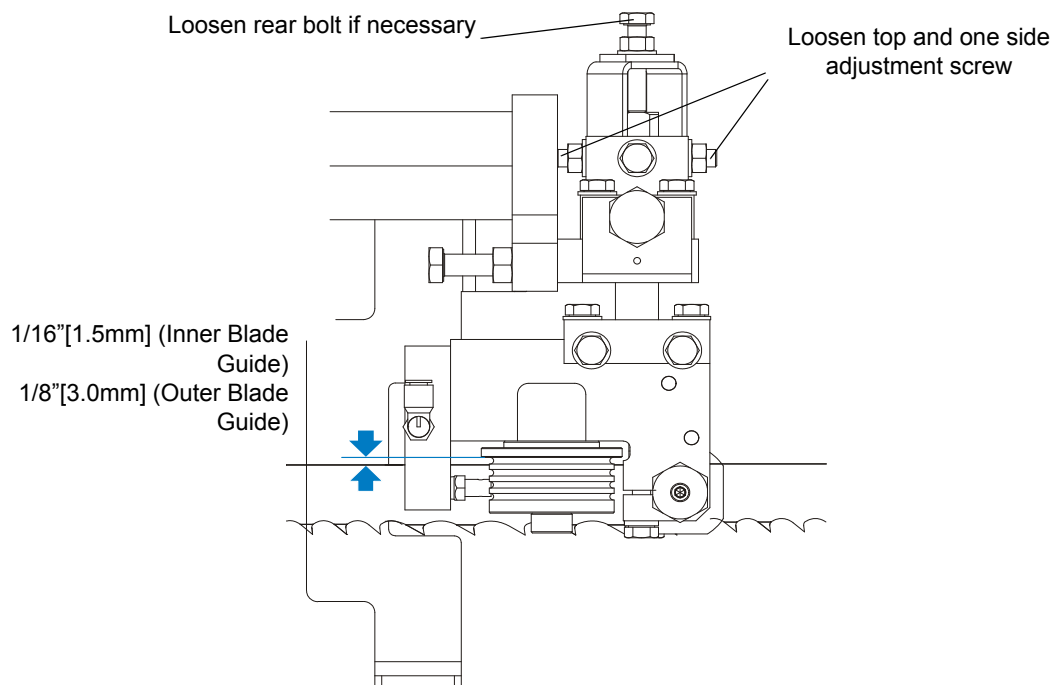

FIG. 5-12

2. Measure the distance between the flange on the outer blade guide roller to the back edge of the blade. This distance should measure 1/8" (3.0 mm). Adjust the roller back or forward if necessary.

5.2 Horizontal Adjustment of Side Supports

1. Place a flat board on the bed rails, parallel to the main bed rail.
2. Swing the side support down.
3. Pull back at the top of the support to eliminate slack as if a log were being clamped against it.

See Figure 5-13.

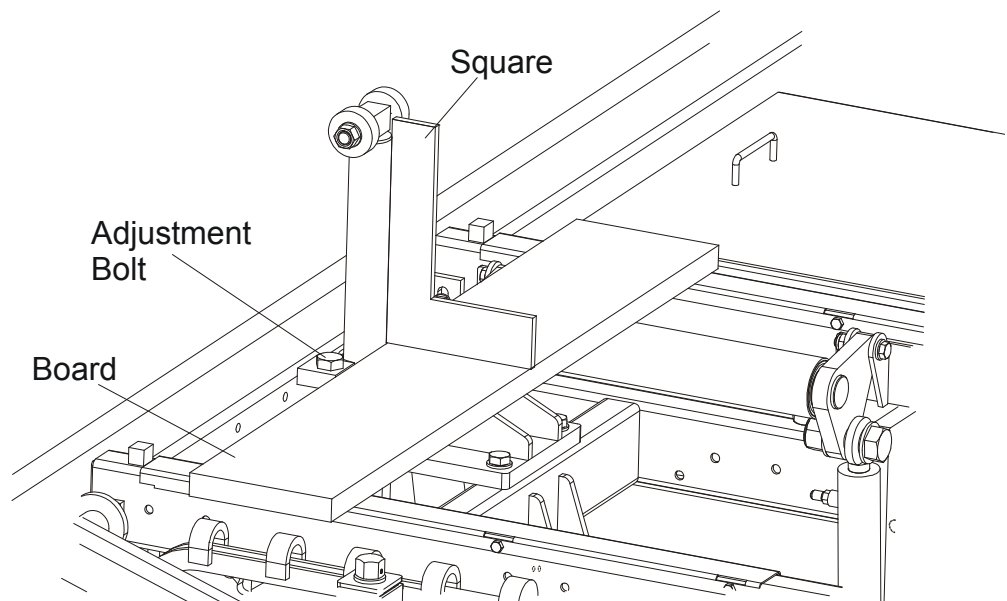

FIG. 5-13

4. Check the angle of each support with a square on the board.
5. The side support should be 90° to the bed rails. If not, loosen the top adjustment bolt, adjust the side support, and retighten the bolt.
6. Repeat for the remaining side supports.

Blade Height Scale Adjustment

After the entire sawmill has been aligned and all adjustments made, check that the blade height scale indicates the true distance from the blade to the bed rails.

1. Move the saw head so the blade is positioned directly above one of the bed rails. Measure from the bottom edge on a down-set tooth of the blade to the top of the bed rail, near the inner blade guide assembly.
2. View the blade height scale with eyes level with the indicator. The scale should indicate the actual distance from the blade to the bed rail. Adjust the indicator if necessary.

See Figure 5-14. Loosen the indicator bracket mounting bolts and adjust the bracket until the indicator is aligned with the correct mark on the scale. Retighten the bracket mounting nuts.

Example: if the measurement from the down-set tooth of the blade to the bed rail was 14 3/4" (375 mm), make sure the indicator reads 14 3/4" (375 mm) on the scale.

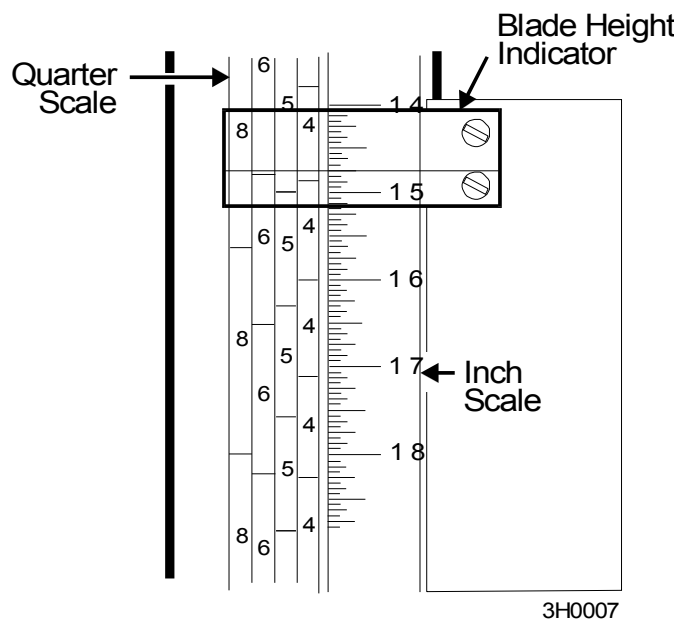
**FIG. 5-14**

5.3 Complete Alignment Procedure

Frame Setup

Before performing the following alignment procedures, setup the mill on firm, level ground.

If your sawmill is stationary, with no trailer axle, lower the feet so the weight of the sawmill is evenly supported.

If your sawmill has a trailer axle and adjustable outriggers, adjust the outriggers as follows:

LT70M DH: Adjust the two end outriggers on the main frame tube down just enough to lift weight from the trailer tire.

All portable sawmills: Adjust the outer outriggers down just so they touch the ground but do not bear weight.

See [SECTION 3](#) for additional setup information.

Blade Installation

1. Remove the blade and replace the blade wheel belts. New blade wheel belts are required to perform the complete alignment procedure.
2. Blow sawdust off of the blade guide assemblies. Remove sawdust from the blade housings. Scrape any sawdust buildup from the blade wheel rims.
3. Remove the blade guide assemblies and the blade.

NOTE: To remove the blade guide assemblies and maintain the tilt adjustments, only loosen one side screw and the top screw.

4. Adjust the outer blade guide arm in or out until the outer blade guide is approximately 24" (61 cm) from the inner blade guide.
5. Install a new blade and apply the appropriate tension ([See Section 2.5](#)).
6. Close the blade housing covers and make sure all persons are clear of the saw head.
7. Turn the key switch to #2 position.
8. Turn the key switch to #3 position. Manually spin one of the blade wheels until the blade positions itself on the blade wheels.

Blade Wheel Alignment

The blade wheels should be adjusted so they are level in the vertical and horizontal planes. If the blade wheels are tilted up or down, the blade will want to travel in the tilted direction. If the blade wheels are tilted horizontally, the blade will not track properly on the wheels.

1. Use the blade guide alignment tool to check the vertical alignment of each blade wheel. Attach the tool to the blade near the inner blade guide mount. Be sure the tool does not rest on a tooth or burr, and is lying flat against the bottom of the blade.

See Figure 5-15.

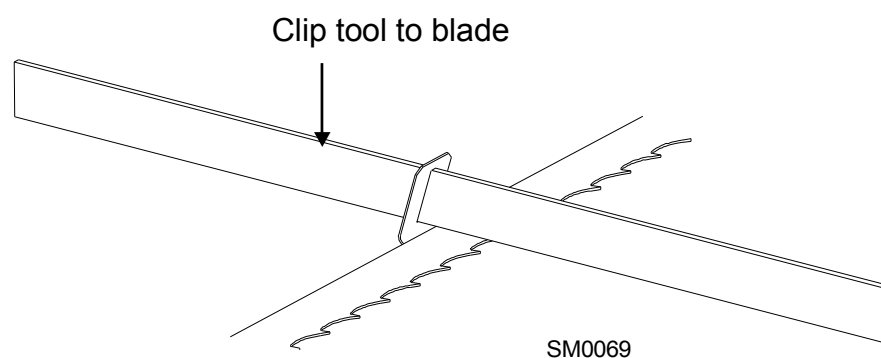

FIG. 5-15

2. Move the saw carriage so the front end of the tool is positioned over the first bed rail. Measure from the bottom of the tool to the top surface of the bed rail.
3. Move the saw carriage so the rear of the tool is positioned over the bed rail. Again, measure from the bottom of the tool to the bed rail.
4. If the two measurements differ by more than 1/16" (1.5 mm), adjust the vertical tilt of the drive-side blade wheel.

See Figure 5-16. Use the vertical adjustment screws to adjust the drive-side blade wheel. To tilt the wheel down, loosen the top adjustment screw one quarter turn. Loosen the jam nut on the bottom adjustment screw and tighten the screw. Tighten the top and bottom jam nuts.

To tilt the wheel up, loosen the bottom adjustment screw one quarter turn. Loosen the jam nut on the top adjustment screw and tighten the screw. Tighten the top and bottom jam nuts.

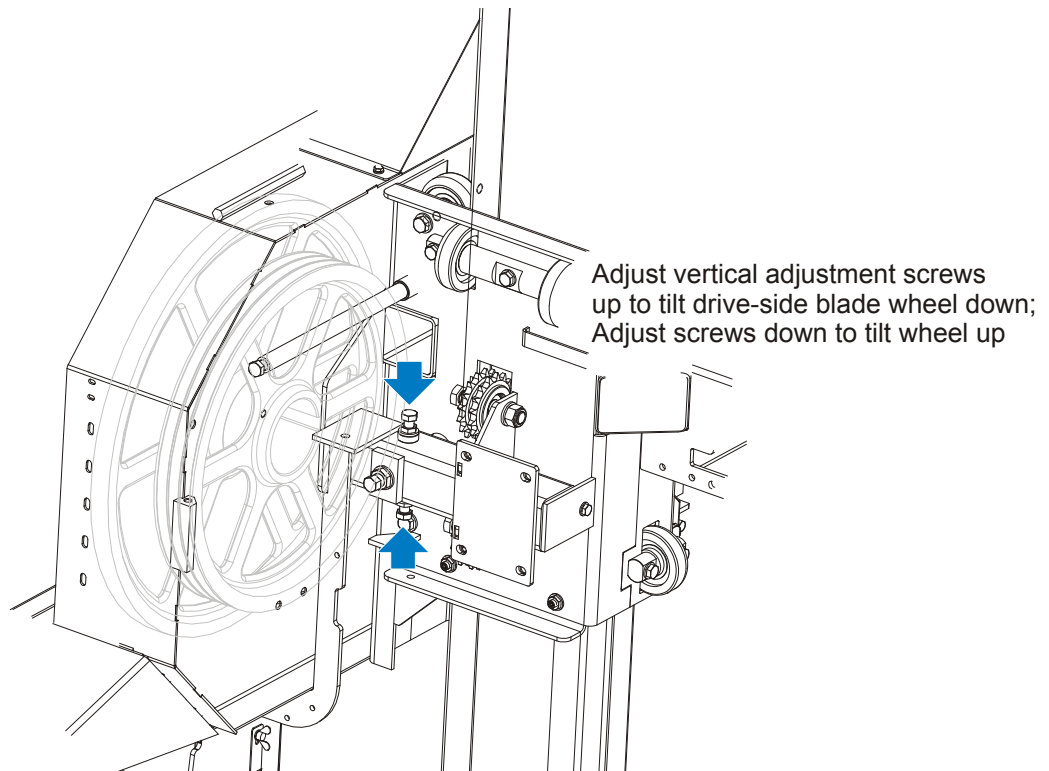

FIG. 5-16

5. Recheck the vertical tilt of the drive-side blade wheel with the blade guide alignment tool. Readjust the blade wheel as necessary until the front and rear of the tool are the same distance from the bed rail (within 1/16" [1.5 mm]).
6. Remove the tool from the blade and reattach it near the outer blade guide assembly.
7. Measure from the tool to the bed rail at both ends of the tool. If the measurements at the front and rear ends of the tool differ by more than 1/16" (1.5 mm), adjust the vertical tilt of the idle-side blade wheel.

See Figure 5-17. Use the vertical adjustment screws to adjust the idle-side blade wheel. To tilt the wheel up, loosen the bottom adjustment screw one quarter turn. Loosen the jam nut on the top adjustment screw and tighten the screw. Tighten the top and bottom jam nuts.

To tilt the wheel down, loosen the top adjustment screw one quarter turn. Loosen the jam nut on the bottom adjustment screw and tighten the screw. Tighten the top and bottom jam nuts.

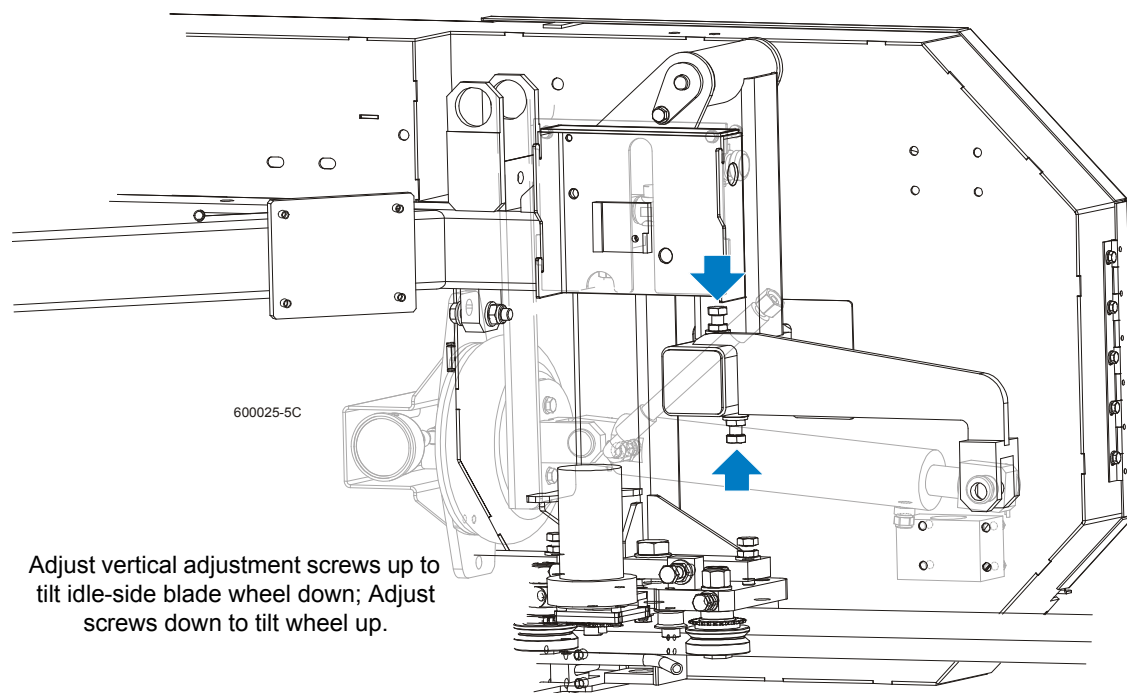

FIG. 5-17

8. Recheck the vertical tilt of the idle-side blade wheel with the blade guide alignment tool. Readjust the blade wheel as necessary until the front and rear of the tool are the same distance from the bed rail (within 1/16" [1.5 mm]).

9. Check the position of the blade on the idle-side blade wheel.

See Figure 5-18. The horizontal tilt of the blade wheel should be adjusted so that the gullet of a 1-1/4" blade is 1/8" (3 mm) out from the front edge of the wheel ($\pm 1,5$ mm). The gullet of a 1-1/2" blade should be 3/16" (4.5 mm) out from the front edge of the wheel ($\pm 1/26$ [1 mm]). Do not let the teeth ride on the wheels.

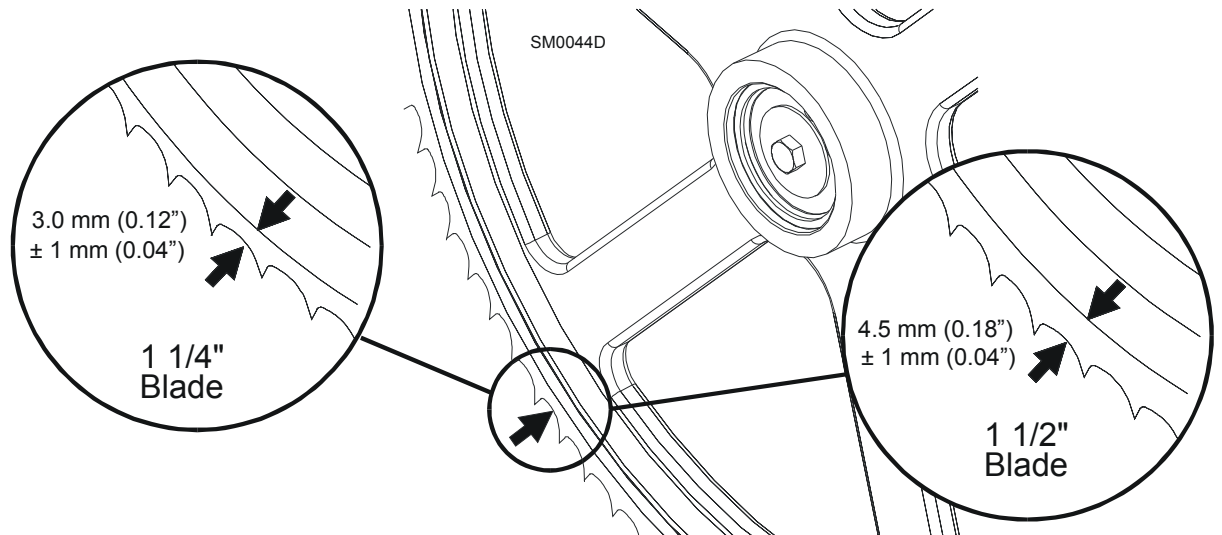

FIG. 5-18

See Figure 5-19. Use the cant control adjustment to adjust the idle-side blade wheel. If the blade is too far forward on the wheel, turn the cant control clockwise. If it is too far back on the wheel, turn the cant control counterclockwise.

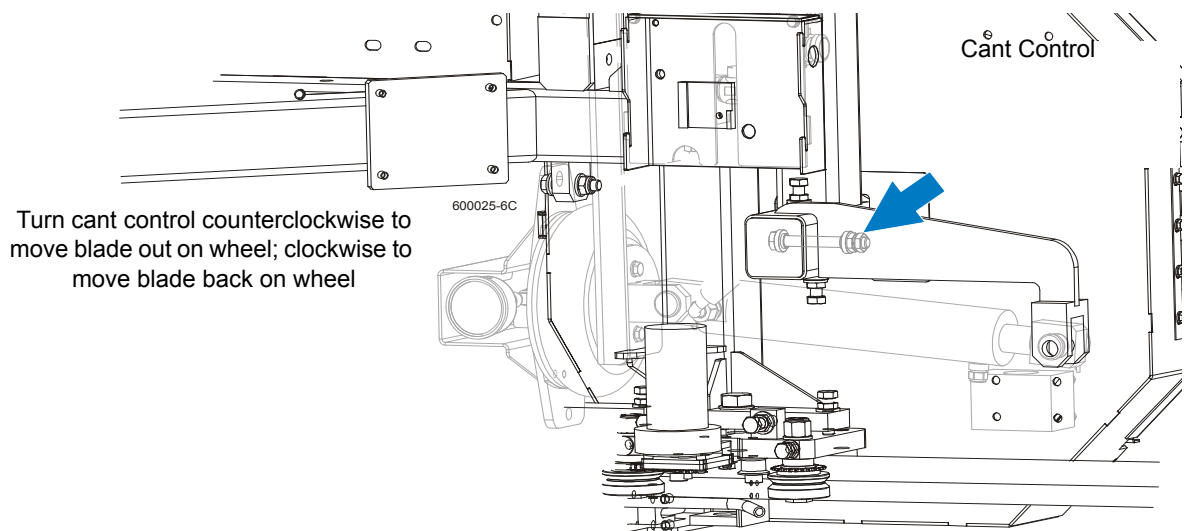

FIG. 5-19

10. Check the position of the blade on the drive-side blade wheel. The blade should be positioned on the wheel as described for the idle-side blade wheel. Adjust the drive-side blade wheel if necessary.

5

Sawmill Alignment

Complete Alignment Procedure

See Figure 5-20. Use the horizontal adjustment screw to adjust the drive-side blade wheel. To move the blade back on the wheel, loosen the jam nut on the adjustment screw and tighten the screw. Tighten the jam nut.

To move the blade out on the wheel, loosen the jam nut on the adjustment screw and loosen the screw. Tighten the jam nut.

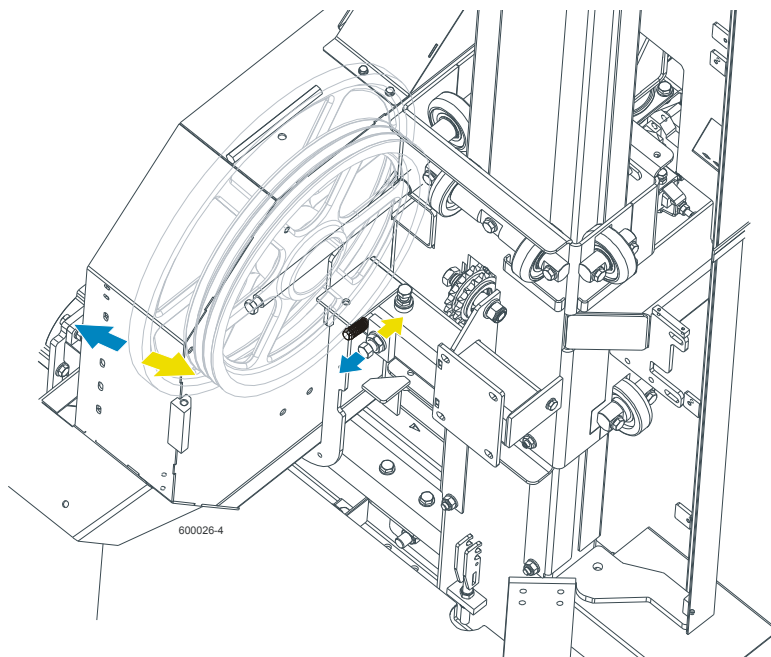

Loosen adjustment bolt to move blade out on wheel; Tighten adjustment bolt to move blade in on wheel

FIG. 5-20

Bed Rail Adjustment

1. Open the adjustable blade guide arm to within 1/2" (15 mm) of full open..
2. Move the carriage back to the front pivot bed rail. Move the carriage back to the front pivot bed rail. Raise the cutting head until the bottom of the blade is 17" (400 mm) above the outside of the pivot bed rail support by actual measurement with a tape or ruler.
3. Move the carriage forward to check the distance to the blade at the inside of the pivot bed rail support. All measurements should be equal.

See Figure 5-21. To adjust the saw head tilt, use the bolts located at the bottom of the saw head mast. Loosen the three sets of four retaining plate bolts. To raise the outside of the saw head, back the stop bolts out, then tighten the adjustment bolts. To lower the outside of the saw head, loosen the adjustment bolts and tighten the stop bolts. Recheck the saw head tilt and readjust the bolts as necessary. Retighten the retaining plate bolts.

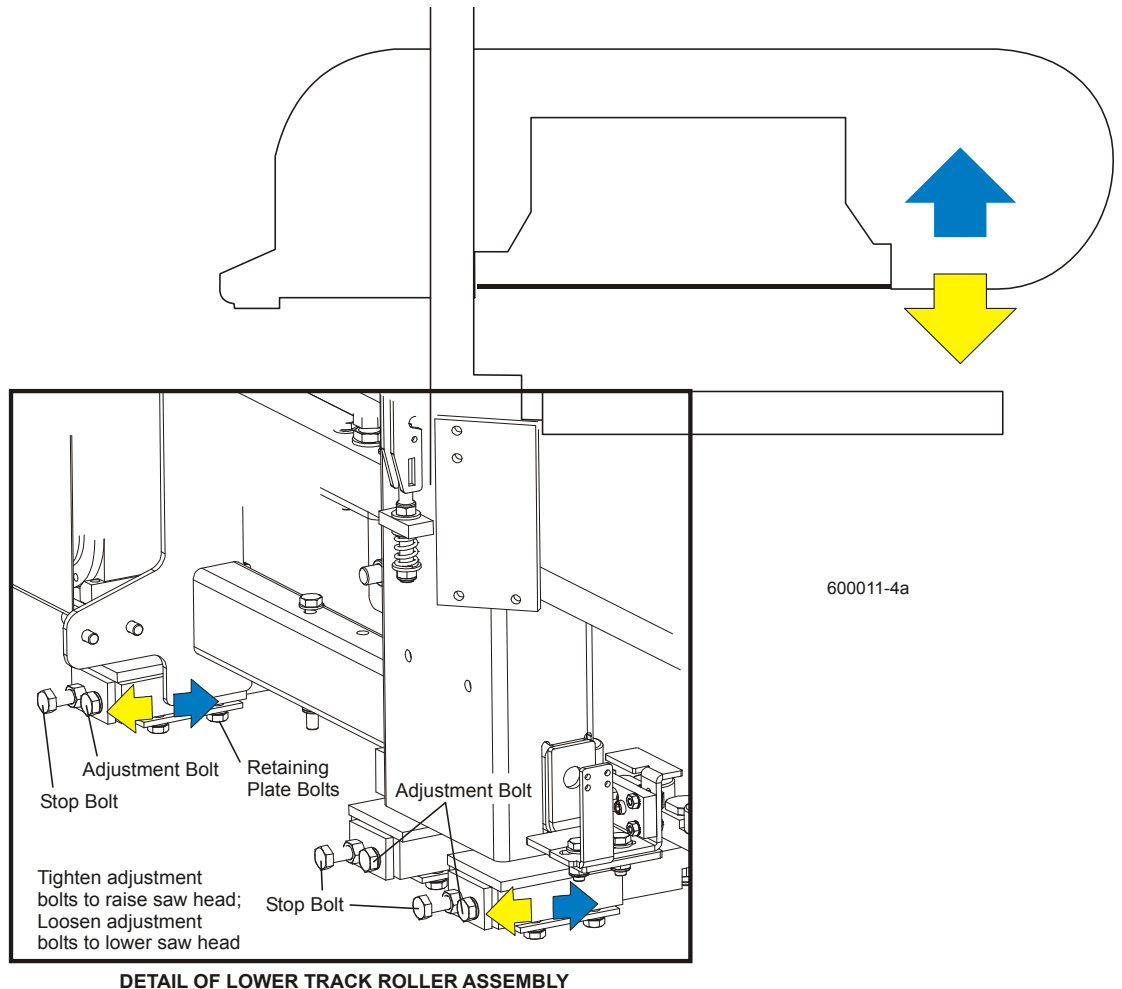

FIG. 5-21

5**Sawmill Alignment***Complete Alignment Procedure*

4. Move the clamp so it is 10" from the clamp stop. Adjust the clamp down to its lowest position. Move the saw head forward until it is positioned over the clamp. Raise the saw head until the blade measures 15 5/16" (385 mm) from the clamp at its lowest position.
5. Adjust the front pivot rail 90° to the main bed tube.
6. Move the saw head to center the blade over the front pivot bed rail.

7. Measure the distance from the top of the pivot rail to the bottom of the blade. Make this measurement at each end of the pivot rail.
8. The two measurements should be 15" 375 mm.
9. Loosen the locking set screws and turn the inner height adjustment nut to adjust the height of the inner end of the pivot rail. Loosen the jam nut and turn the outer adjustment bolt to adjust the height of the outer end of the pivot rail.
10. Move the saw head so the blade is positioned over the center of the front main bed rail.
11. Measure the distance between the bottom of the blade and the bed rail at each end of the bed rail. The bed rail should measure 15" (375 mm) from the blade to the bed rail (+1mm at the outer side).

See Figure 5-22. Loosen the bed rail clamping bolts and turn the adjustment bolts to move the bed rails to the blade if necessary. Retighten the clamping bolts and adjustment bolt jam nuts.

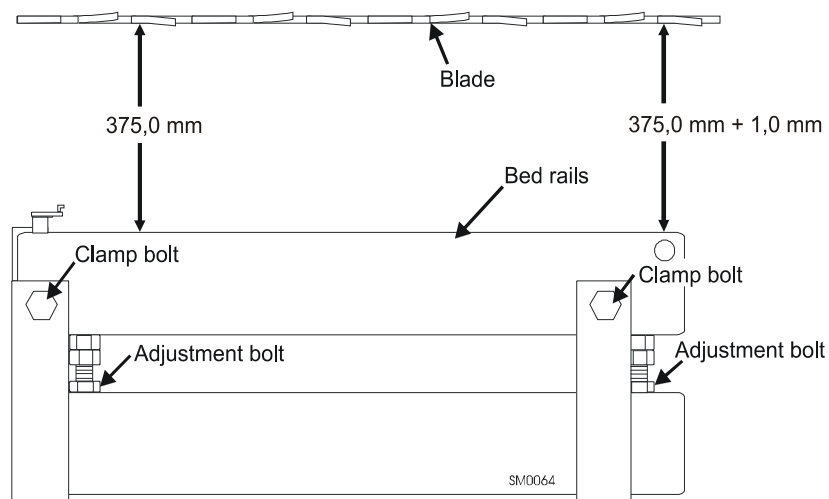

FIG. 5-22

12. Without adjusting the saw head height, check the three remaining main bed rails and the rear pivot rail. Adjust them so that all measure the same distance from the blade at both ends of the bed rail.

Blade Guide Installation

Each Wood-Mizer sawmill has two blade guide assemblies that help the blade maintain a straight cut. The two blade guide assemblies are positioned on the saw head to guide the blade on each side of the material being cut.

One blade guide assembly is mounted in a stationary position on the drive side of the saw head. This assembly is referred to as the "inner" blade guide assembly.

The other blade guide assembly is mounted on the idle side of the saw head. It is referred to as the "outer" assembly and is adjustable for various widths of materials to be processed.

NOTE: Before installing the blade guide assemblies, remove the blade guide adjusting screws and apply a lubricating oil such as 10W30 or Dexron III to each screw. This will prevent the screws and threaded holes from corroding and make screw adjustments easier.

1. Inspect the guide disks and repair or replace as necessary. Remove the blade from the sawmill.

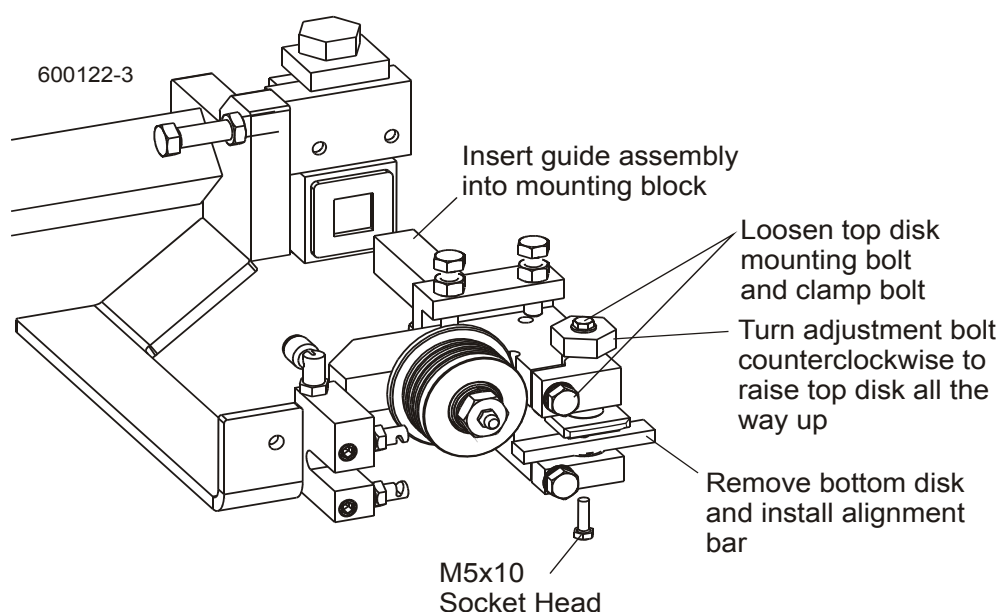

FIG. 5-22

2. Loosen the top disk clamp bolt and mounting bolt. Turn the adjustment bolt counterclockwise to raise the top disk all the way up. Remove the bottom guide disk from each blade guide assembly and install the provided alignment bar.
3. Install each blade guide assembly to the mounting blocks and push all the way back. Install, tension and track a new blade. Adjust the outer blade guide assembly so the roller flange is 1/8" from the back of the

blade. Adjust the inner blade guide assembly so the roller flange is 1/16" from the blade.

See Figure 5-23.

Tighten the two previously-loosened tilt adjustment screws to secure the blade guide assembly. Turn the top adjustment bolt clockwise to raise the blade guide assembly so it does not touch the blade.

NOTE: Before adjusting the top bolt, unload pressure on the bolt by turning 1/2 turn in the opposite direction it was last adjusted.

With the roller flange positioned properly from the back of the blade, adjust the rear bolt so it touches the end of the blade guide mounting shaft.

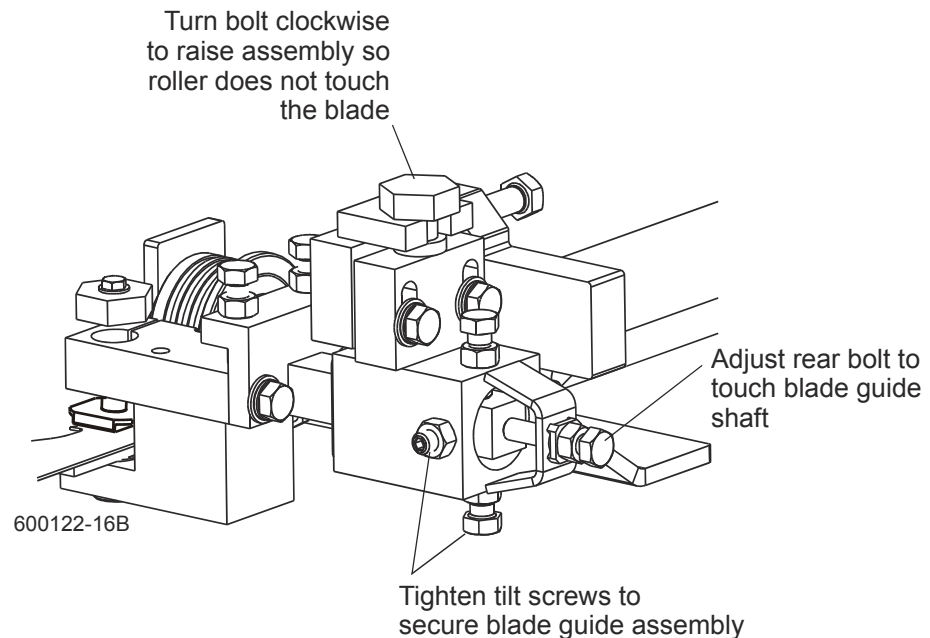

FIG. 5-23

Blade Guide Arm Alignment

The blade guide arm moves the outer blade guide in and out. If the arm becomes loose, the blade guide will not deflect the blade properly, causing inaccurate cuts. A loose blade guide arm can also cause blade vibration.

1. Adjust the blade guide arm in to 1/2" (15 mm) from fully closed.
2. Manually try to move the arm up and down. If you can move the arm by hand, you will need to tighten the arm rollers.

See Figure 5-24. Loosen the jam nuts and turn the adjustment bolts in to tighten the blade guide arm rollers. Retighten the jam nuts. After tightening the blade guide arm rollers, check that the arm is aligned properly.

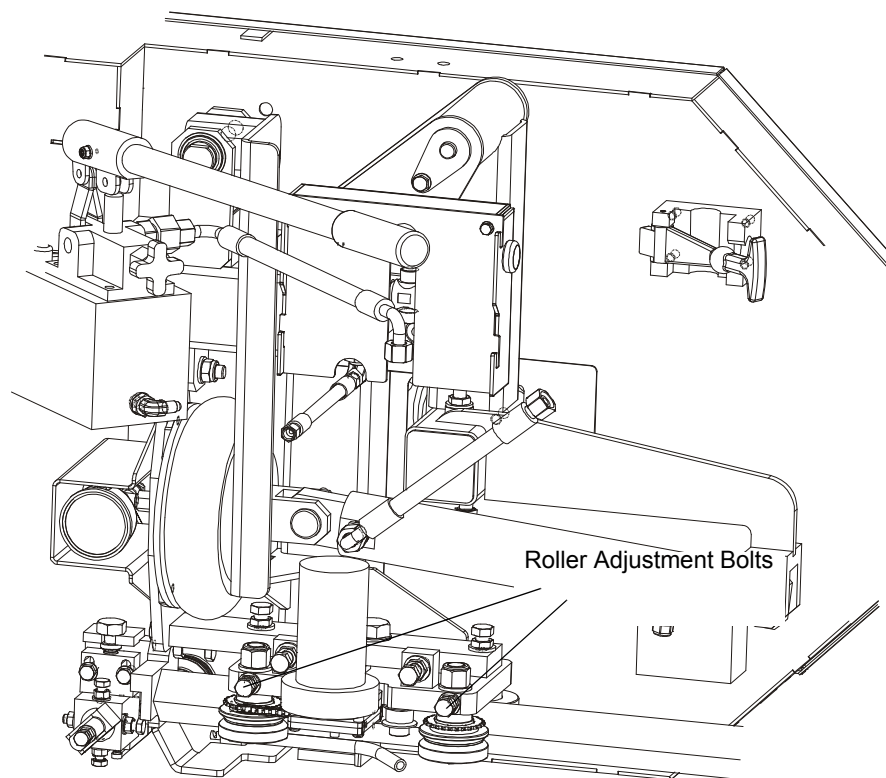

FIG. 5-24

3. With the arm adjusted 1/2" (15 mm) from fully closed, measure the distance between the rear blade guide roller and the back of the blade.

See Figure 5-25.

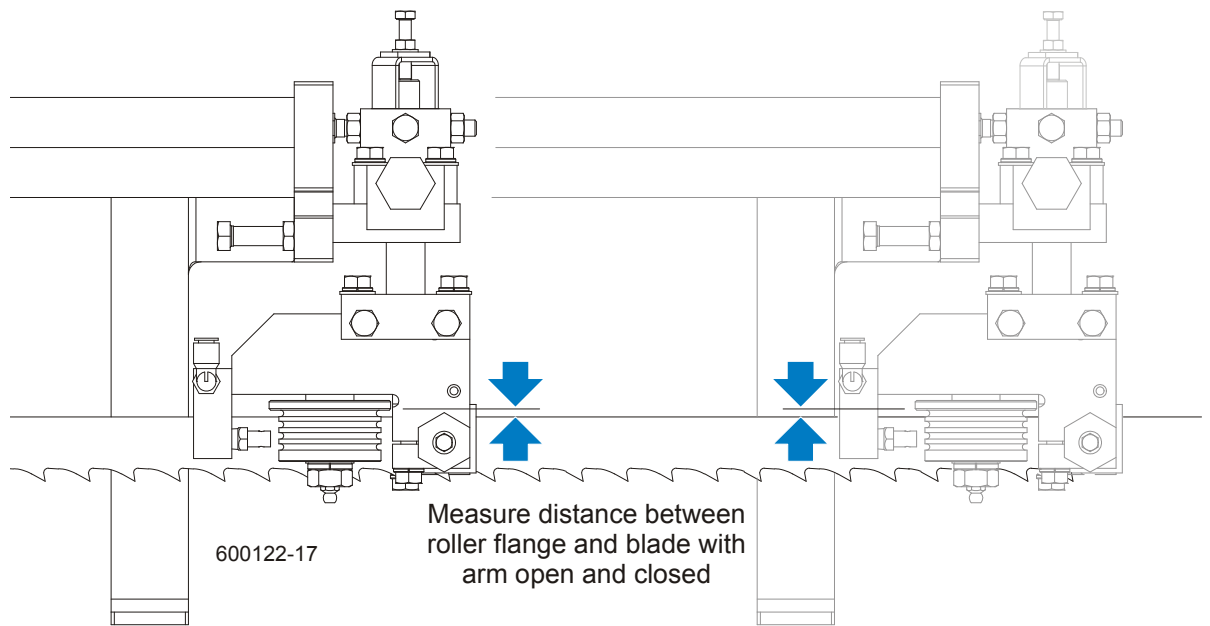

FIG. 5-25

4. Adjust the blade guide arm to 1/2" (15 mm) from fully open and remeasure the distance from the roller flange to the back of the blade. The two measurements should be the same. If not, adjust the outer rollers in or out to tilt the arm horizontally.

5

Sawmill Alignment*Complete Alignment Procedure*

See Figure 5-26. Loosen the adjustment bolt jam nuts. To tilt the arm in toward the blade, loosen the right bolt and tighten the left bolt. To tilt the arm out away from the blade, loosen the left bolt and tighten the right bolt. Retighten the jam nuts and recheck the blade guide arm horizontal tilt..

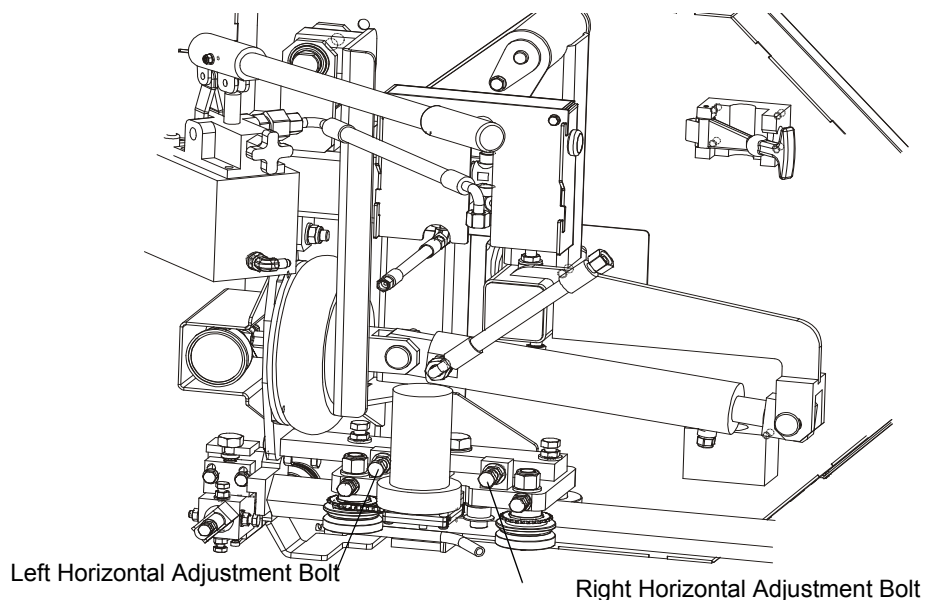

FIG. 5-26

5. Now check the vertical tilt of the blade guide arm. Move the saw carriage so the blade guide arm is positioned over a bed rail.
6. With the arm 1/2" (15 mm) from fully closed, raise or lower the saw head until the bottom of the blade guide block is 15" (375 mm) from the top of the bed rail.

See Figure 5-27. Adjust the blade guide arm to 1/2" (15 mm) from fully open. Measure the distance from the bottom of the blade guide mounting block to the bed rail. This measurement should be 15" (376 mm). If the measurements are not the same, adjust the blade guide arm vertically.

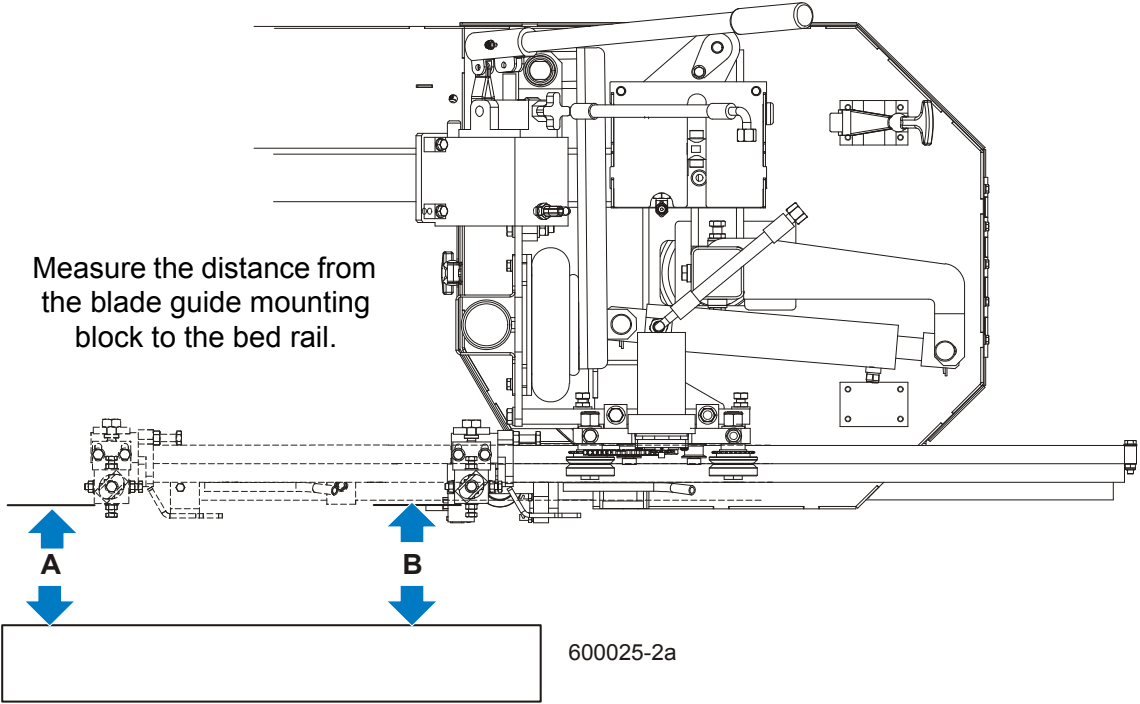
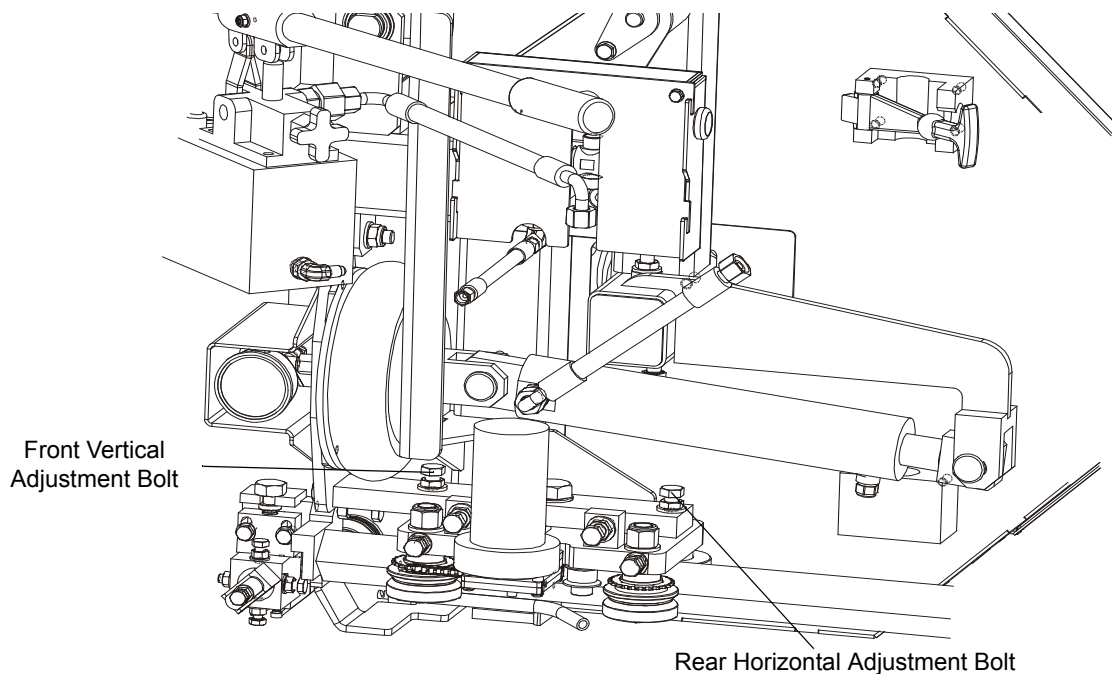

FIG. 5-27

5**Sawmill Alignment***Complete Alignment Procedure*

See Figure 5-28. Loosen the vertical adjustment bolt jam nuts. To tilt the blade guide arm down, loosen the rear bolt and tighten the front bolt. To tilt the blade guide arm up, loosen the front bolt and tighten the rear bolt. Retighten the jam nuts and recheck the blade guide arm vertical tilt.

**FIG. 5-28**

Blade Guide Deflection

Perform the following steps to achieve proper blade deflection with the blade guides.

1. Raise the carriage until the blade is 375 mm above a bed rail. Measure the actual distance with a tape from the top of the rail to the bottom of the blade.

See Figure 5-29.

Turn the top adjustment bolt counterclockwise to lower the assembly until the blade guide roller deflects the blade down until the bottom of the blade measures 369 mm from the bed rail. Tighten the clamp bolts.

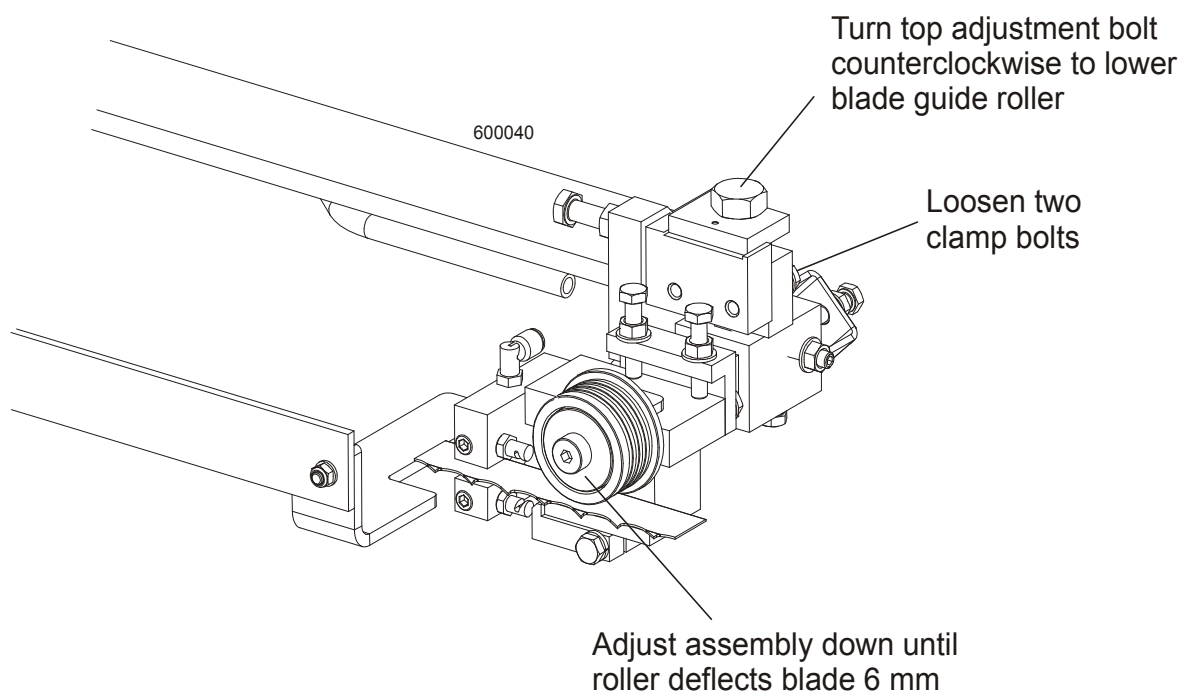

FIG. 5-29

2. Repeat for the other blade guide.

Blade Guide Vertical Tilt Alignment

The blade guides should be adjusted properly in the vertical plane. If the blade guides are tilted vertically, the blade will try to travel in the tilted direction.

A Blade Guide Alignment Tool (BGAT) is provided to help you measure the vertical tilt of the blade.

1. Open the adjustable blade guide arm 1/2" (15 mm) from full open.
2. Clip the alignment tool on the blade. Position the tool close to the outer blade guide roller. Be sure the tool does not rest on a tooth or burr, and is lying flat on the blade.

See Figure 5-30.

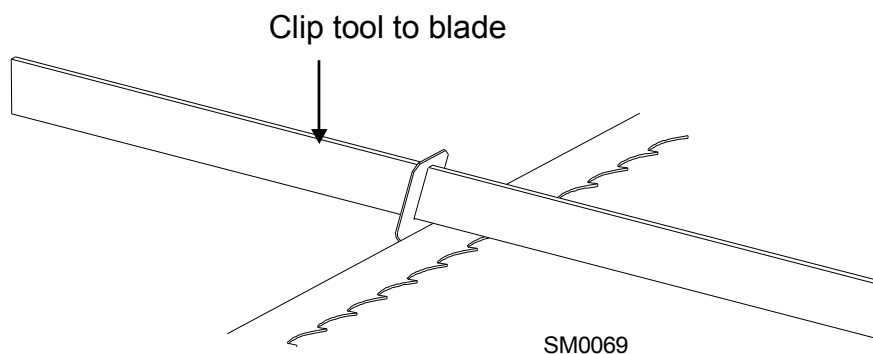

FIG. 5-30

3. Move the carriage so that the front end of the tool is positioned above the bed rail. Measure the distance from the bed rail to the bottom edge of the tool.
4. Move the carriage so that the back end of the tool is positioned above the bed rail. Measure the distance from the bed rail to the bottom edge of the tool.
5. If the measurement from the tool to the bed rail is not equal, adjust the vertical tilt of the outer blade guide roller.

See Figure 5-31. Loosen the jam nuts on the top and bottom vertical tilt adjustment screws. To tilt the roller

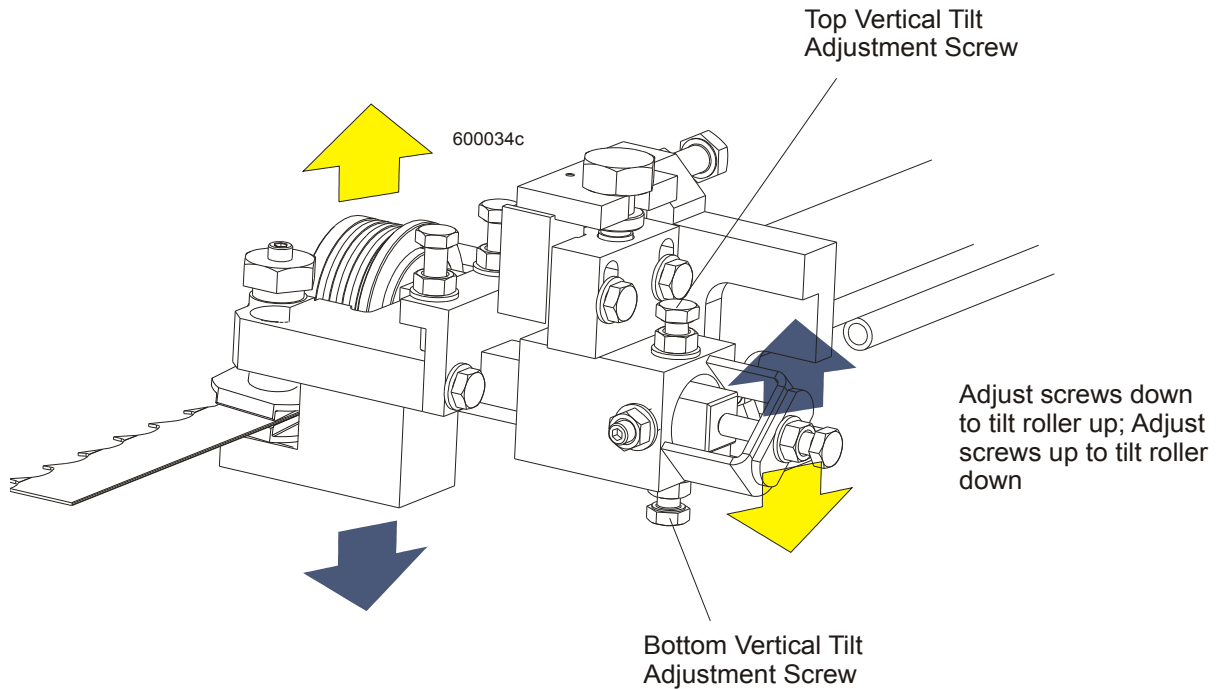

FIG. 5-31

up, loosen the bottom screw and tighten top screw. To tilt the roller down, loosen the top screw and tighten the bottom screw. Tighten the jam nuts and recheck the tilt of the blade.

6. Move the blade guide alignment tool close to the inner blade guide roller assembly and repeat the above steps. Adjust the vertical tilt of the inner blade guide if necessary.
7. After adjusting the vertical tilt of the blade guides, recheck the blade deflection and adjust if necessary.

Blade Guide Horizontal Tilt Adjustment

If the blade guides are tilted in the wrong direction horizontally, the back of the blade may contact the flange as the roller is spinning down, causing it to push the blade away from the guide roller.

1. Remove the blade guide alignment tool from the blade and adjust the blade guide arm halfway in.
2. Remove the clip from the blade guide alignment tool. Place the tool against the face of the outer blade guide roller.

See Figure 5-32.

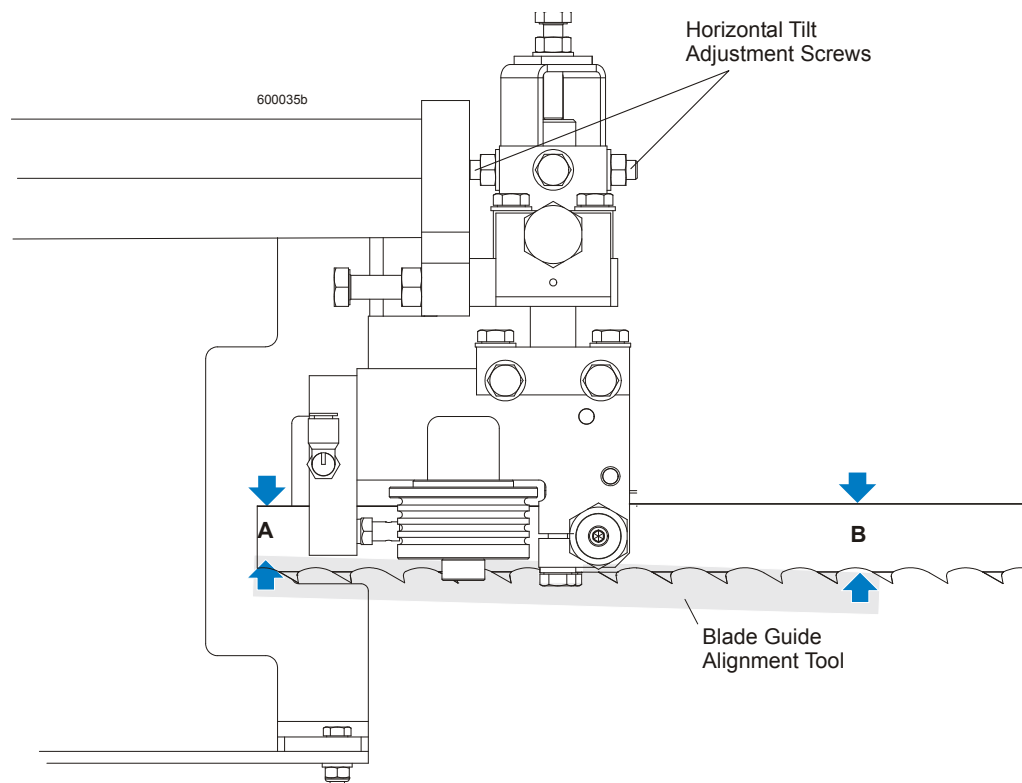

FIG. 5-32

3. Measure between the back edge of the blade and the tool at the end closest to the inner blade guide ("B").
4. Measure between the back edge of the blade and the other end of the tool ("A").

The roller should be tilted slightly to the left ('A' 1/8" [3 mm] less than 'B' \pm 1/8" [3 mm]).

See Figure 5-33. Loosen the jam nuts on the horizontal tilt adjustment screws. To tilt the roller left, loosen the right screw and tighten left screw. To tilt the roller right, loosen the left screw and tighten the right screw. Tighten the jam nuts and recheck the tilt of the blade.

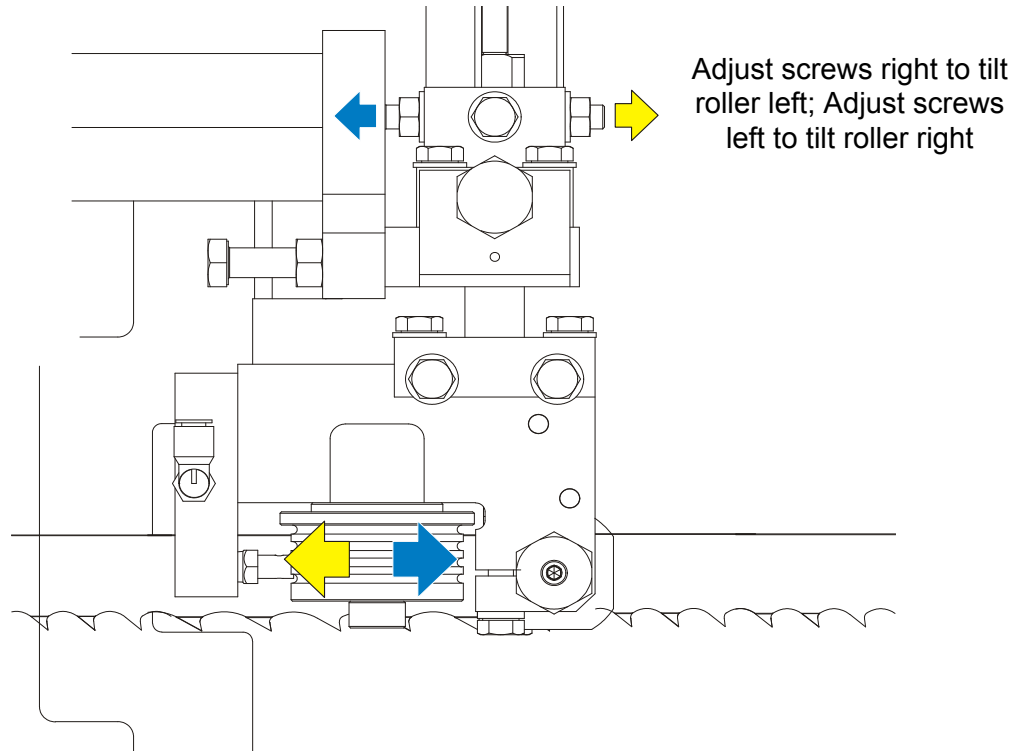

FIG. 5-33

5. Repeat the above steps for the inner blade guide roller assembly.

NOTE: Once the blade guides have been adjusted, any cutting variances are most likely caused by the blade. [See the Blade Handbook, Form #600.](#)

Blade Guide Flange Spacing

Each blade guide must be adjusted so the roller flange is the correct distance from the back edge of the blade. If the flange is too close to or too far from the blade, the sawmill will not cut accurately.

HINT: When adjusting blade guide spacing, loosen the top set screw and one side set screw only. This will ensure horizontal and vertical tilt adjustments are maintained when the adjustment screws are retightened.

1. Measure the distance between the flange on the inner blade guide roller to the back edge of the blade. This distance should measure 1/16" (1.5 mm). Adjust the roller back or forward if necessary.

See Figure 5-34. Loosen the top and one side screw shown and rear adjusting bolt if necessary. Tap the blade guide forward or backward until properly positioned. Retighten the screws and jam nuts.

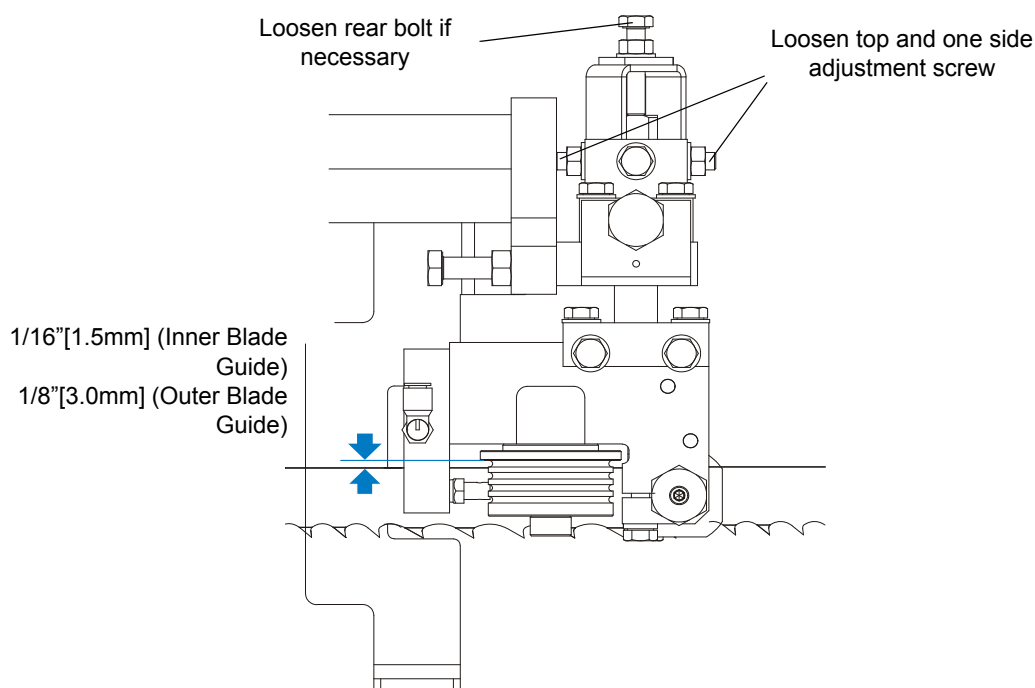

FIG. 5-34

2. Measure the distance between the flange on the outer blade guide roller to the back edge of the blade. This distance should measure 1/8" (3.0 mm). Adjust the roller back or forward if necessary.
3. Check the blade guide disks and drive side deflector plate are properly adjusted. ([See Section 5.2](#)).

Blade Guide Level

Perform the following adjustments to make sure the blade guide assembly is parallel to the blade.

1. Loosen the alignment bar mounting bolt. Use the provided bottom disk adjustment tool to adjust the alignment bar up so the bar is close to, but not touching the bottom of the blade. Retighten the alignment bar

mounting bolt.

2. Check that the gap from the alignment bar to the blade is the same along entire length of the bar. Shine a flashlight behind the blade guide assembly to help you see the gap between the bar and the blade. To adjust, loosen the rear clamp bolts, but leave snug. Determine which outer bolt to use to tilt the blade guide assembly as desired. Loosen the jam nut and turn the bolt until the alignment bar is parallel to the blade. Retighten the jam nut and clamp bolts. Repeat for the second blade guide assembly.

See Figure 5-35.

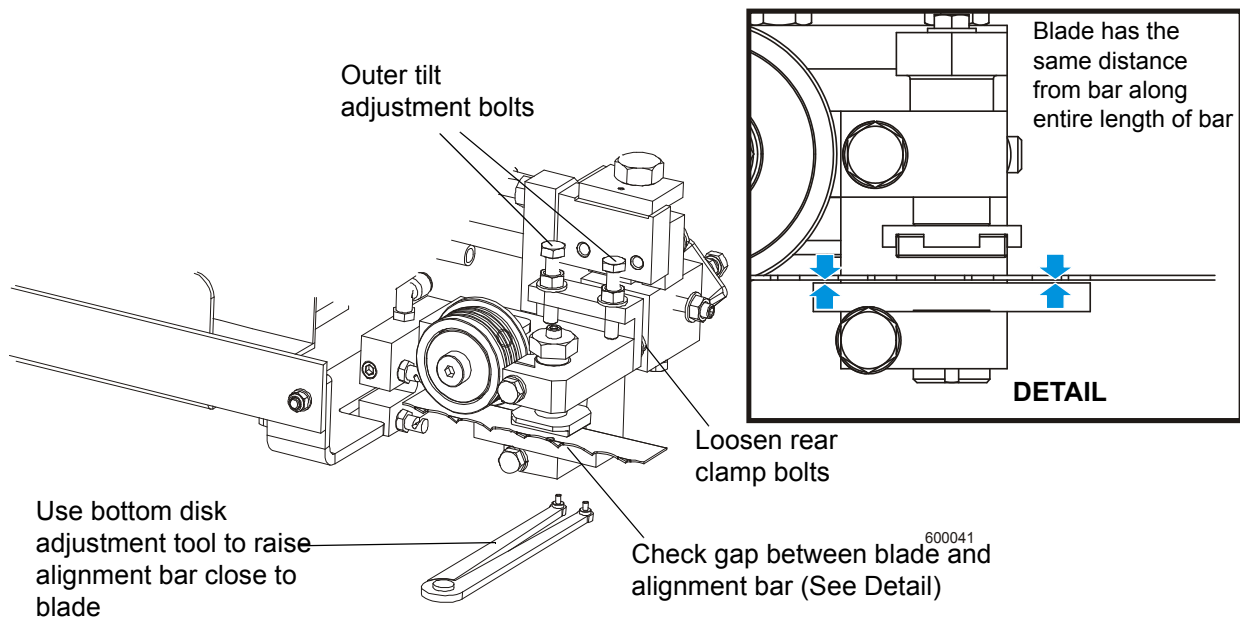

FIG. 5-35

Blade Disk Adjustment

1. Remove the blade and remove the alignment bars from the blade guide assemblies. Install new or reconditioned bottom guide disks to both blade guide assemblies (leave mounting bolts loose). Use the provided bottom disk adjustment tool to lower the bottom disk all the way down. Install, tension and track the blade.

See Figure 5-36.

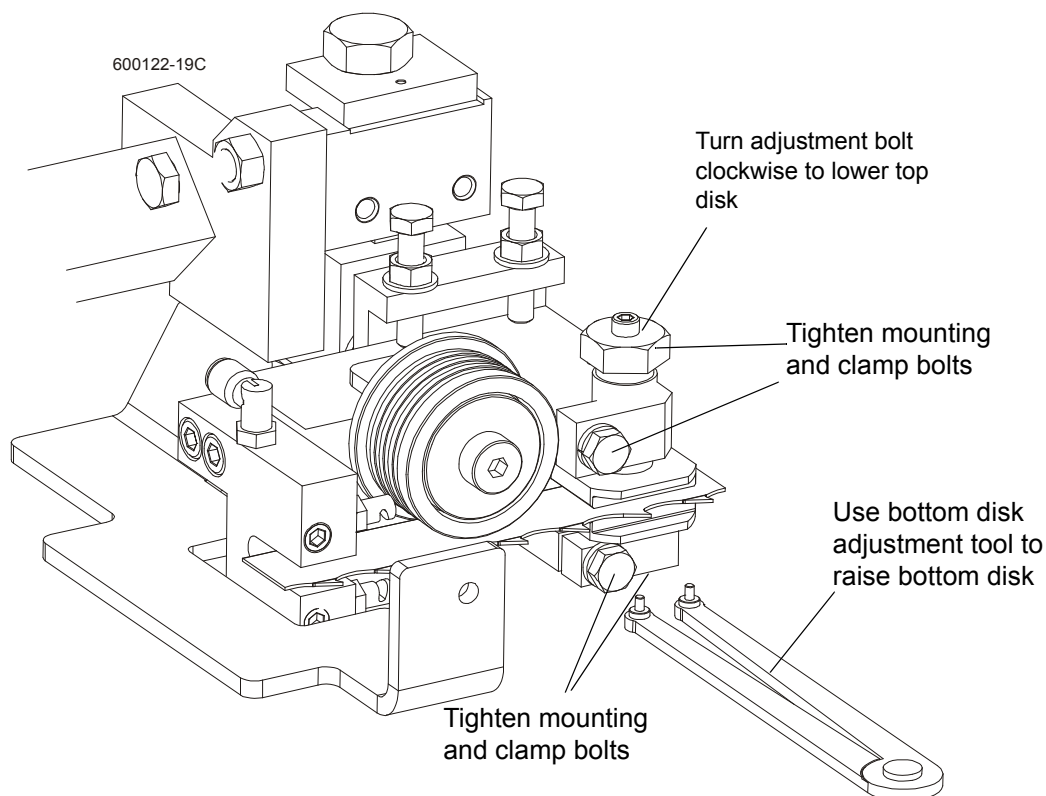

FIG. 5-36

2. Use the bottom disk adjustment tool to raise the bottom disk to 0.3-0.5 mm from the blade. Use the provided shim to set the distance from the disk to the blade. Tighten the bottom disk mounting bolt and clamp bolt.
3. Turn the top disk adjustment bolt clockwise to lower the top disk to 0.3 -0.5 from the blade (using the shim as a guide). Tighten the top disk mounting bolt and clamp bolt.
4. After tightening the clamp bolt, recheck the distance from the top disk to the blade and readjust if necessary.

Vertical Adjustment of Side Supports

1. Place a flat board on the bed rails.
2. Swing a side support up so that it is vertical.
3. Pull back at the top of the support to eliminate slack as if a log were being clamped against it.

See Figure 5-37.

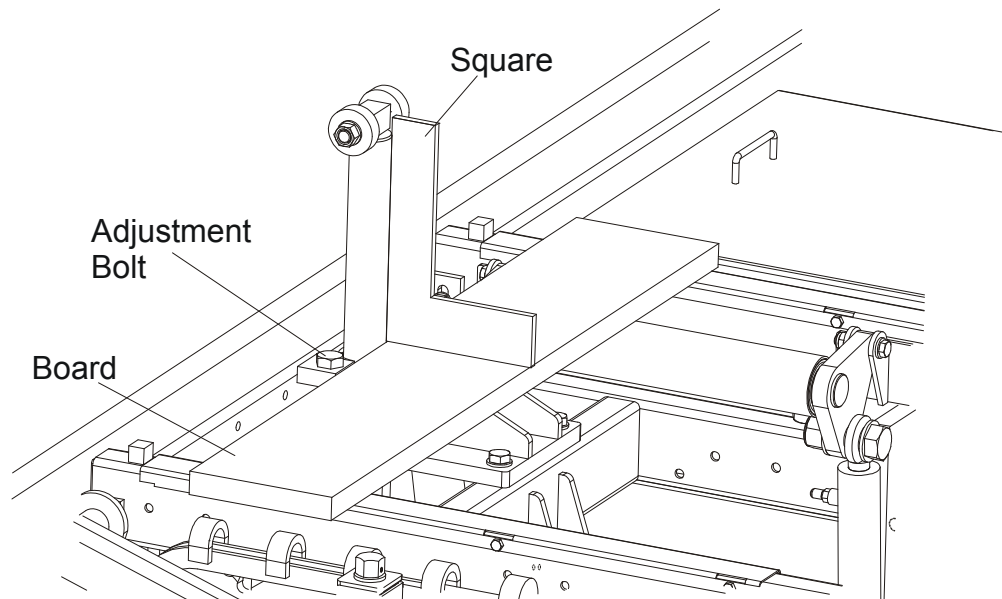

FIG. 5-37

4. Check the angle of each support with a square on the board.
5. The side support should be 90° to the bed rails. Loosen the top adjustment bolt, adjust the side support, and retighten the bolt.
6. Repeat for the remaining side supports.

Clamp Stop/Stop Bolt Adjustment

1. Once the side supports are aligned, pivot them down to their horizontal position.
2. Tie a string across the face of the side supports.

Loosen the clamp stop bolts and adjust the clamp stop until it touches the string.

Saw Head Tilt

As the blade enters a wide log or cant, the outside of the saw head will drop down slightly. To compensate for the drop, the saw head is adjusted 1/16" (1.5 mm) higher at the outside.

1. Move the saw carriage so the blade is positioned over a bed rail. Adjust the blade guide arm to 1/2" (15 mm) from full open. The saw head should still be adjusted so the blade is 14 3/4" (375 mm) above the bed rails.

See Figure 5-38.

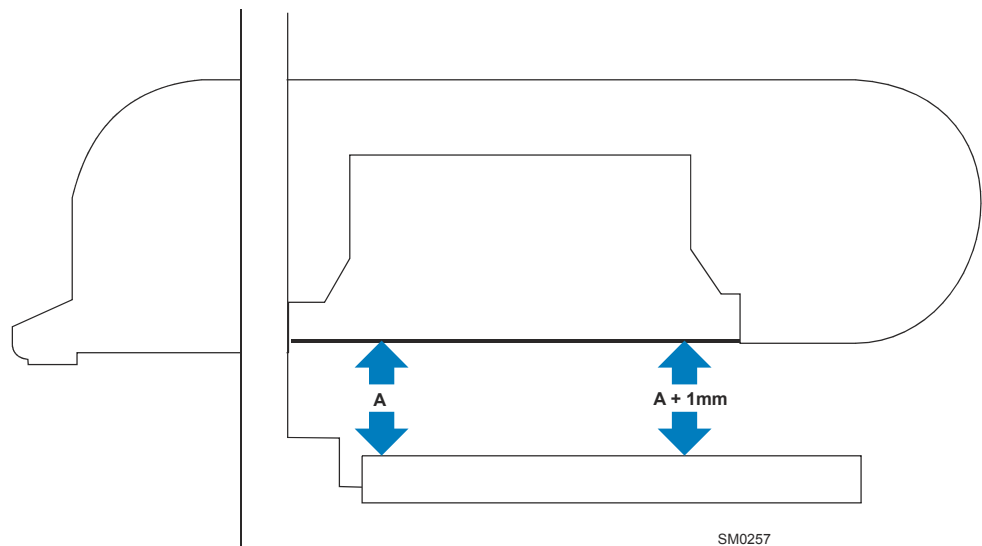

FIG. 5-38

2. Measure from the blade to the bed rail near the outer blade guide assembly. This measurement should be 1/16" (1.5 mm) higher than the inner measurement.

5

Sawmill Alignment

Complete Alignment Procedure

See Figure 5-39. To adjust the saw head tilt, use the bolts located at the bottom of the saw head mast. Loosen the three sets of four retaining plate bolts. To raise the outside of the saw head, back the stop bolts out, then tighten the adjustment bolts. To lower the outside of the saw head, loosen the adjustment bolts and tighten the stop bolts. Recheck the measurement from the blade to the bed rails and adjust the stop bolts and adjustment bolts until the outside of the saw head is 1/16" higher than the inside..

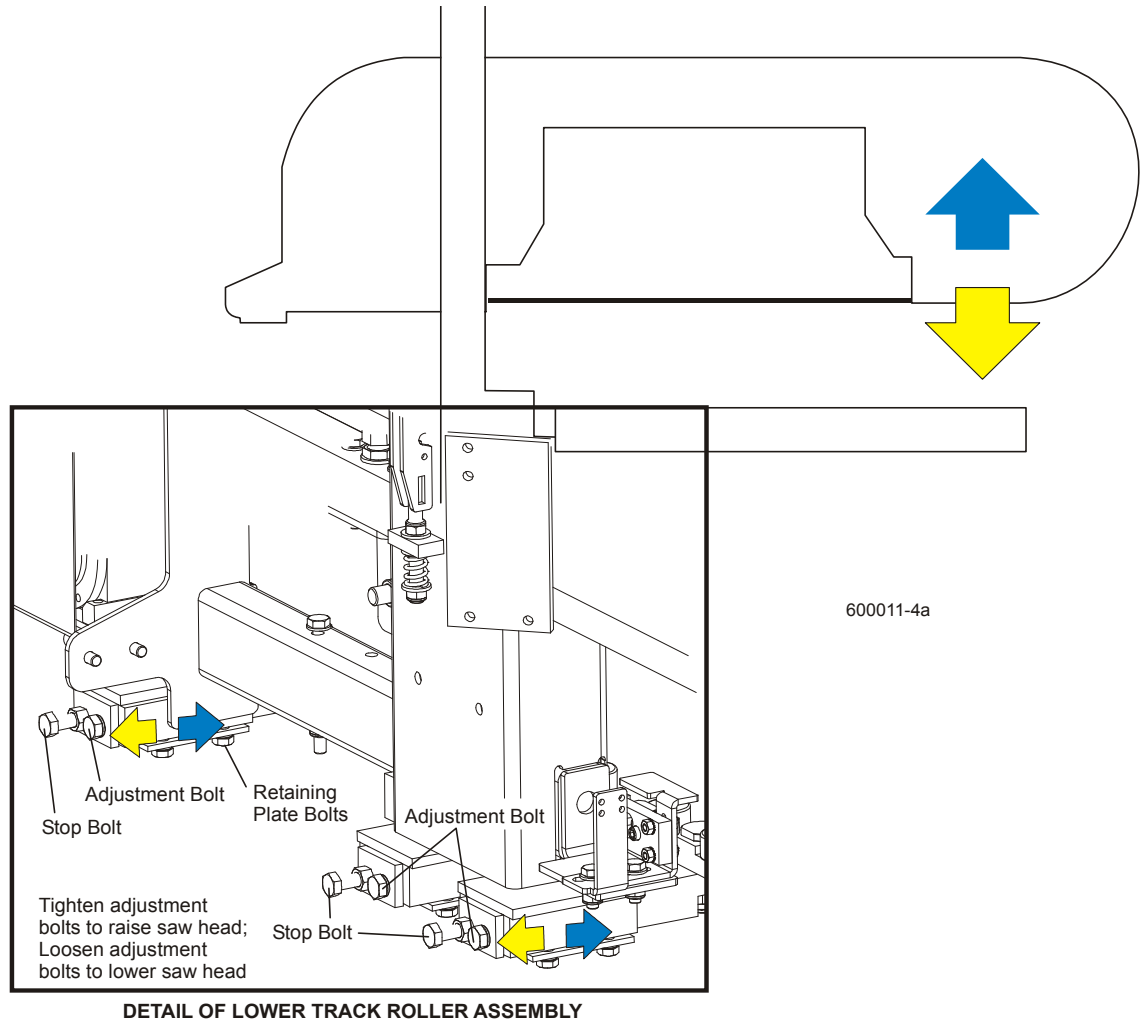

FIG. 5-39

Blade Height Scale Adjustment

After the entire sawmill has been aligned and all adjustments made, check that the blade height scale indicates the true distance from the blade to the bed rails.

1. Move the saw head so the blade is positioned directly above one of the bed rails. Measure from the bottom edge on a down-set tooth of the blade to the top of the bed rail, near the inner blade guide (or stainless steel sleeve if applicable).

See Figure 5-40.

2. View the blade height scale with eyes level with the indicator.

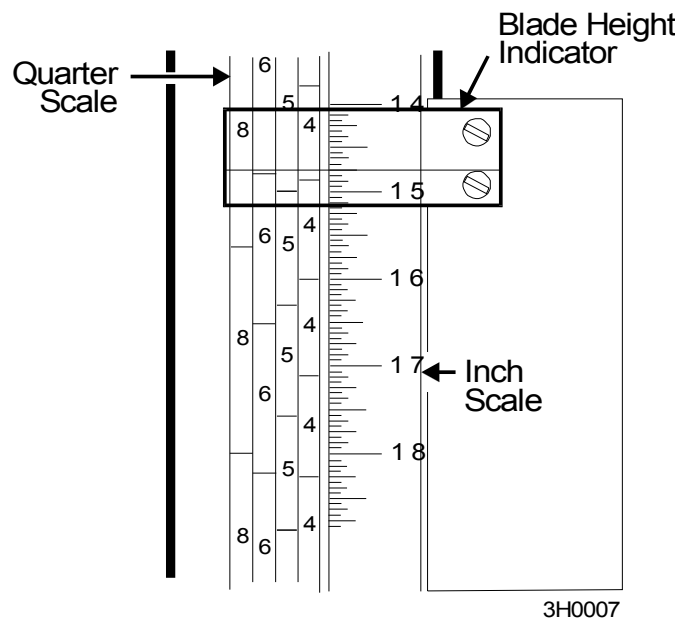

FIG. 5-40

3. Loosen the indicator bracket mounting bolts and adjust the bracket until the indicator is aligned with the correct mark on the scale. Retighten the bracket mounting nut..

For example, if the measurement from blade to bed rail was 14 3/4" (375 mm), make sure the indicator reads 14 3/4" (375 mm) on the scale.

SECTION 6 MOTOR BRAKE

6.1 Maintenance/repair

Wear of spring – applied brakes

INTORQ spring – applied brakes are wear-resistant and designed for long maintenance intervals. The friction lining and the mechanical brake components are subject to function-related wear. For safe and trouble-free operation, the brake must be checked and readjusted at regular intervals, and, if necessary, be replaced. The following table describes different causes of wear and their effects on the components of the spring-applied brake. For calculating the service life of rotor and brake and determining the maintenance intervals to be observed, the relevant factors of influence must be quantified. The most important factors are the friction work, initial speed of braking and the operating frequency. If several of the causes of wear indicated for the friction lining occur in an application at the same time, the influencing factors must be added for calculating the wear.

Inspections

To ensure safe and trouble-free operation, spring-applied brakes must be checked and maintained at regular intervals. Servicing can be made easier if good accessibility of the brakes is provided in the plant. This must be considered when installing the drives in the plant. Primarily, the necessary maintenance intervals for industrial brakes result from the load during operation. When calculating the maintenance interval, all causes for wear must be taken into account. If the brakes are not maintained, failures, production outages or plant damages may be the result. Thus, a maintenance concept adapted to the operating conditions and loads of the brake must be developed for every application. The maintenance intervals and maintenance work listed in the following table must be scheduled for the spring-applied INTORQ brake.

Maintenance intervals

Service brakes	<ul style="list-style-type: none"> ■ according to service life calculation ■ otherwise every six months ■ after 4000 operating hours at the latest
-----------------------	---

TABLE 6-1.

6.2 Maintenance



IMPORTANT! Brakes with defective armature plates, cheese head screws, springs or flanges must be replaced completely.

Please observe the following for inspections and maintenance operations:

- Remove impurities through oil and grease using brake cleaning agents, if necessary, replace brake after finding out the cause of the contamination. Dirt deposits in the air gap between stator and armature plate impair the function of the brake and must be removed.
- After replacing the rotor, the original braking torque will not be reached until the run-in operation of the friction surfaces has been completed. After replacing the rotor, run-in armature plates and flanges have an increased initial rate of wear.

Checking the rotor thickness



DANGER! The motor must not be running when checking the rotor thickness.

- Remove the motor cover and seal ring (if mounted).
- Measure the rotor thickness with a caliper gauge. On brakes with friction plates, observe edging on outer diameter of friction plate.
- Compare measured rotor thickness with minimally permissible rotor thickness [See Table 12-2](#)
- Replace the complete rotor if necessary.

Check air gap

- Measure the air gap "sL_ü" between armature plate and rotor using a feeler gauge (see chapter 3.3).
- Compare the measured air gap to the maximum permissible air gap "sL_{ümax}." (see table below).
- If necessary, adjust air gap to "sL_{ü rated}".

Brake Type	sL _{ü rated} +0.1mm -0.05mm	sL _{ü max} Service Brake	Max. adjustment permissible wear	Rotor thickness		Excess of the adjuster nut h _{E max} . [mm]
				min. ¹⁾ [mm]	max. [mm]	
INTORQ BFK458-25	0,4 mm (1/64")	1,0 mm (3/64")	4,0 mm (5/32")	12 mm (15/32")	16 mm (5/8")	17 mm (43/64")

TABLE 12-2

EC declaration of conformity according to EC Machinery Directive 2006/42/EC Annex II, 1.A

We herewith declare,

Wood-Mizer Industries sp. z o.o.
114 Nagorna street, 62-600 Kolo; Poland.

That the following described machine in our delivered version complies with the appropriate basic safety and health requirements of the EC Machinery Directive 2006/42/EC based on its design and type, as brought into circulation by us. In case of alteration of the machine, not agreed by us, this declaration is no longer valid.

Designation of the machine:	SAWMILL
TYPE:	LT70
Model:
No. of manufacturer:
Applicable EC Directives:	EC Machinery Directive 2006/42/EC EC Electromagnetic Compatibility Directive 2004/108/EC
Applicable Harmonized Standards:	PN-EN ISO 12100:2012 PN-EN 1807-2:2013-08 PN-EN ISO 13849-1:2008 PN-EN 60204-1:2010 PN-EN ISO 13857:2010 PN-EN ISO 4413:2011
Notified Body according to annex IV :	PZ.LSV; Pruf- und Zertifizierungsstelle des Spitzenverbandes der landwirtschaftlichen Sozialversicherung
Notification No	2157
Responsible for:	EC type examination
EC type-examination certificate no.	LSV-EG-2015/104
Responsible for Technical Documentation:	Adam Kubiak / R&D Manager Wood-Mizer Industries Sp. z o.o. 62-600 Koło, ul. Nagórna 114 Tel. +48 63 26 26 000
Place/Date/Authorized Signature:	Koło, 04.02.2015 Adam Kubiak
Title:	R&D Manager