



## user manual

Instrukcja obsługi | Руководство пользователя  
Manuel de l'Utilisateur | Betriebsanweisung  
Bruksanvisning | Manual del Usuario  
Betjeningsvejledning | Gebruikershandleiding  
Käyttöohjeet | Manual de utilizare | Bruksanvisning  
Manuale d'uso | Příručka uživatele | Navodila  
za uporabo

Retain for future use  
Zachować do przyszłego użytku  
Сохраните для последующего  
использования  
A conserver pour une utilisation future  
Für zukünftige Benutzung aufbewahren  
Behold for senere bruk  
Säilytä nämä käyttöohjeet tulevaa tarvetta marten  
Opbevar manualen til fremtidig brug  
Bewaren voor gebruik in de toekomst  
Conservare il presente manuale a l'uso futuro  
Păstrați acest manual pentru utilizare viitoare  
Conservar para futuras consultas  
Behall för framtida användning  
Uchovejte pro další použití  
Hranite za prihodnjo uporabo



# **Wood-Mizer®**

## **Safety, Setup, Operation & Maintenance Manual**

---

**LT40M AHS**

**rev. A4.01**

---



**Safety is our #1 concern!** Read and understand all safety information and instructions before operating, setting up or maintaining this machine.

*Form #1055*

**This is the original language  
for the manual.**

# Table of Contents

# Section-Page

## **SECTION 1 SAFETY & GENERAL INFORMATION 1-1**

1.1	Safety Symbols.....	1-1
1.2	Blade Handling.....	1-3
1.3	Sawmill Setup.....	1-4
1.4	Sawmill Operation.....	1-5
1.5	Sawmill Maintenance .....	1-8
1.6	Belt Sizes .....	1-15
1.7	Blade Sizes .....	1-16
1.8	Cutting Capacity .....	1-17
1.9	Motor Specifications .....	1-18
1.10	Overall Dimensions .....	1-18
1.11	Chains .....	1-19
1.12	Hydraulic System .....	1-19
1.13	Components.....	1-20
1.14	LT40/70 S/M AH Hydraulic Schematic .....	1-21
1.15	LT40/70 S/M AH Hydraulic Components .....	1-22

## **SECTION 1 SETUP & OPERATION 2-1**

1.1	Sawmill Setup.....	2-1
1.2	Stationary Sawmill Setup .....	2-2
	<i>Sawmills with cable guide</i>	
1.3	Portable Sawmill Setup .....	2-8
1.4	Middle Track Cover .....	2-11
1.5	Replacing The Blade .....	2-12
1.6	Tensioning The Blade.....	2-13
1.7	Tracking The Blade .....	2-14
1.8	Starting The Motor .....	2-16
1.9	Board Return .....	2-18
1.10	Hydraulic Control Operation.....	2-21
1.11	Loading, Turning, And Clamping Logs .....	2-23
1.12	Up/Down Operation .....	2-26
1.13	Blade Guide Arm Operation.....	2-27
1.14	Power Feed Operation .....	2-28
1.15	Cutting The Log .....	2-30
1.16	Wireless Control Panel (option) .....	2-32
1.17	Edging.....	2-33
1.18	Optional Cutting Procedure for Super Series Mills.....	2-34
1.19	Blade Height Scale .....	2-35
1.20	Water Lube Operation .....	2-38
1.21	Preparing The Sawmill For Transportation.....	2-39

## **SECTION 2 MAINTENANCE 3-1**

2.1	Wear Life.....	3-1
-----	----------------	-----

## Table of Contents

## Section-Page

2.2	Blade Guides .....	3-2
	<i>Steel Guide Blocks</i>	
	<i>Throat Screw</i>	
2.3	Sawdust Removal .....	3-5
2.4	Carriage Track, Wiper & Scrapers .....	3-5
2.5	Vertical Mast Rails .....	3-7
2.6	Drum Switches .....	3-7
2.7	Miscellaneous Maintenance .....	3-7
2.8	Drive Belt Adjustment.....	3-8
2.9	Up/Down System.....	3-9
2.10	Power Feed .....	3-11
2.11	Hydraulic System .....	3-11
2.12	Safety Devices Inspection .....	3-13
<b>SECTION 3        TROUBLESHOOTING</b>		<b>4-1</b>
3.1	Sawing Problems .....	4-1
3.2	Electrical Problems.....	4-3
3.3	Power Feed Problems .....	4-4
3.4	Hydraulic Problems .....	4-6
3.5	Engine/Motor Drive Pulleys Alignment.....	4-9
3.6	Power Feed Variable Speed Switch Test.....	4-9
3.7	Power Feed Preliminary Test .....	4-9
3.8	Power Feed Mechanical Test.....	4-9
3.9	Circuit Breaker Operation .....	4-10
<b>SECTION 4        SAWMILL ALIGNMENT</b>		<b>5-1</b>
4.1	Pre-Alignment Procedures.....	5-1
4.2	Frame Setup.....	5-2
4.3	Blade Installation And Alignment.....	5-3
4.4	Saw Head Slide Pad Adjustment .....	5-6
4.5	Adjusting The Lower Track Rollers.....	5-8
4.6	Adjusting Bed Rails To The Blade.....	5-10
4.7	Blade Guide Arm Vertical Adjustment .....	5-13
4.8	Blade Guide Arm Horizontal Adjustment.....	5-15
4.9	Aligning the Blade Guides .....	5-17
4.10	Blade Deflection.....	5-18
4.11	Blade Guide Vertical Tilt Adjustment.....	5-19
4.12	Blade Guide Spacing .....	5-21
4.13	Horizontal Tilt Adjustment.....	5-22
4.14	Blade Guide Disc Adjustment.....	5-23
4.15	Horizontal Adjustment of Side Supports.....	5-24
4.16	Vertical Adjustment of Side Supports.....	5-25
4.17	Clamp Stop/Stop Bolt Adjustment .....	5-26

## Table of Contents

## Section-Page

4.18	Saw Head Tilt.....	5-27
4.19	Blade Height Scale Adjustment.....	5-28

## SECTION 1 SAFETY & GENERAL INFORMATION

### 1.1 Safety Symbols

The following symbols and signal words call your attention to instructions concerning your personal safety. Be sure to observe and follow these instructions.



The word **DANGER** indicates an imminently hazardous situation which, if not avoided, will result in death or serious injury.



**WARNING** suggests a potentially hazardous situation which, if not avoided, could result in death or serious injury.



**CAUTION** refers to potentially hazardous situations which, if not avoided, may result in minor or moderate injury to persons or equipment.



Warning stripes are placed on areas where a single decal would be insufficient. To avoid serious injury, keep out of the path of any equipment marked with warning stripes.

Read and observe all safety instructions before operating this equipment! Also read any additional manufacturer's manuals and observe any applicable safety instructions including dangers, warnings, and cautions.

Always be sure that all safety decals are clean and readable. Replace all damaged safety decals to prevent personal injury or damage to the equipment. Contact your local distributor, or call your Customer Service Representative to order more decals.

**IMPORTANT!** It is always the owner's responsibility to comply with all applicable federal, state and local laws, rules and regulations regarding the ownership, operation and towing of your Wood-Mizer sawmill. All Wood-Mizer mill owners are encouraged to become thoroughly familiar with these applicable laws and comply with them fully while using or towing the mill.

Always properly dispose of all sawing by-products, including sawdust and other debris, coolant, oil, fuel, oil filters and fuel filters.

Safety instructions are listed in this section by the following operations:

# 1

## **Safety & General Information**

### *Safety Symbols*

---

- Blade Handling
- Sawmill Setup
- Sawmill Operation
- Sawmill Maintenance



## 1.2 Blade Handling



**DANGER!** Always disengage the blade and shut off the sawmill engine before changing the blade. Failure to do so may result in serious injury.



**WARNING!** Always wear gloves and eye protection when handling bandsaw blades. Changing blades is safest when done by one person! Keep all other persons away from area when coiling, carrying or changing a blade. Failure to do so may result in serious injury.



**WARNING!** Do not spin the blade wheels by hand. Failure to do so may result in serious injury.

### 1.3 Sawmill Setup



**WARNING!** Chock the trailer wheels to prevent movement before unhitching it from the towing vehicle. Failure to do so will result in serious injury or death.

**WARNING!** Put front outrigger down before moving cutting head from the rest position. Failure to do so may result in serious injury.

**WARNING!** Securely fasten the feet of a stationary sawmill to the floor before operating the sawmill. Failure to do so will result in serious injury or death.

**WARNING!** Always make sure the trailer is supporting the sawmill frame when operating a sawmill with adjustable outriggers. Failure to do so will result in serious injury or death. The adjustable outriggers are intended to support the saw frame with assistance from the trailer.

**WARNING!** Do not set up the mill on ground with more than a 10 degree incline. If setup on an incline is necessary, put blocks under one side of the mill or dig out areas for outrigger legs to keep mill level. Setting up the mill on an incline could cause it to tip over, resulting in serious personal injury.



**CAUTION!** Changes in temperature could cause increased pressure in the blade tensioner and loss of fluid from the gauge. Release the blade tension when the mill is not in use to avoid damage to the tensioner.



**CAUTION!** Dismount hydraulic log turner leg before transportation in mobile sawmills.

## 1.4 Sawmill Operation



**DANGER!** Make sure all guards and covers are in place and secured before operating or towing the sawmill. Failure to do so may result in serious injury.

Be sure the blade housing and pulley covers are closed.

**DANGER!** Always keep hands away from moving bandsaw blade. Failure to do so may result in serious injury.

**DANGER!** Stay clear of the area between the trailer axle and saw carriage. Failure to do so may result in serious injury.

**DANGER!** Keep all persons out of the path of moving equipment and logs when operating sawmill or loading and turning logs. Failure to do so may result in serious injury.

**DANGER!** Maintain a clean and clear path for all necessary movement around the mill and lumber stacking areas. Failure to do so may result in serious injury.

**DANGER!** Always be sure the blade is disengaged and all persons are away from the blade before starting the engine. Failure to do so may result in serious injury.

**DANGER!** Keep all persons out of the path of returning boards. Failure to do so may result in serious injury.



**WARNING!** Always disengage the clutch/brake mechanism whenever the sawmill is not cutting. Failure to do so may result in serious injury.

**WARNING!** Always wear eye, ear, respiration, and foot protection when operating the sawmill. Failure to do so may result in serious injury.

**WARNING!** Be sure the power feed switch is in the neutral position before turning the key switch to the on (#1) or accessory (#3) position. This prevents accidental carriage movement which may cause serious injury or death.



**WARNING!** Secure all loose clothing and jewelry before

operating the sawmill. Failure to do so will result in serious injury or death.

**WARNING!** Always make sure log is clamped securely before sawing. Failure to do so will result in serious injury or death.

**WARNING!** Always leave loading arm halfway up while log is on sawmill bed. Failure to do so will result in serious injury or death.

**WARNING!** The automatic board return is intended to assist a second operator in removing boards quickly. Do not use the board return when operating the sawmill alone. Failure to do so will result in serious injury, death or damage to the equipment.

**WARNING!** Never use the board return table as a platform to stand on. This table is designed and intended to assist in the removal of boards only. Standing on the table may result in serious injury.

**WARNING!** Use ONLY water with the water lube accessory. Never use flammable fuels or liquids. If these types of liquids are necessary to clean the blade, remove it and clean with a rag. Failure to do so will result in serious injury or death.



**CAUTION!** Be sure the pivot rails, turning arm, clamp, and toe boards are below bed level before loading a log onto the bed. Failure to do so may result in machine damage or cause misalignment.

**CAUTION!** Before loading a log, be sure the cutting head is moved far enough forward so the log does not hit it. Damage to the sawmill may result.

**CAUTION!** Always make sure the engine is running before operating the hydraulic controls. Operating the controls without the engine running will result in power drainage from the battery. Holding the hydraulic switches halfway up or down also will cause excessive drainage from the battery.

**CAUTION!** Do not try to force the saw head beyond its

upper and lower travel limits. Damage to the up/down system may result.

**CAUTION!** Always make sure the up/down switch moves to the neutral or off position when released to ensure that the saw head stops moving. Damage to the sawmill may result.

**CAUTION!** Move the hydraulic clamp and turner to provide maximum ground clearance before towing. Failure to do so may result in damage to the sawmill.

**CAUTION!** Be sure to stop the blade when returning the carriage. This will not only prevent the blade from being pulled off and ruined by a wood sliver, but also will increase the life of the blade.

## 1.5 Sawmill Maintenance



**WARNING!** Always secure the cutting head with a chain or a brace before adjusting the up/down chain. The cutting head may fall, causing severe injury or death.

**WARNING!** Always secure the cutting head with a chain or a brace before removing the up/down motor belt. The cutting head may fall, causing severe injury or death.

**WARNING!** Drum switch grease contains Petroleum Hydrocarbon Lubricant. Eye and skin irritant. If introduced into eyes, flush with water for at least 15 minutes. If film or irritation persists, seek medical attention. Wash skin with soap and water. If ingested, do not induce vomiting - contact a physician. **KEEP OUT OF THE REACH OF CHILDREN.**

**CAUTION!** Reinstall the track wiper so that it lightly touches the track rail. If the wiper presses too firmly against the rail, it can cause the power feed to bind.

**CAUTION!** Never use grease on the mast rails as it will collect sawdust.

**CAUTION!** Do not use chain lube. It causes sawdust buildup in chain links.

**CAUTION!** Do not over-tension the up/down chain. Over-tensioning may lead to early failure of the gear reducer.

**CAUTION!** Do not overtighten the feed chain. Damage to the power feed motor may result.



**CAUTION!** Do not overtighten the contact set screws on the hydraulic valve assembly. Overtightening may cause the threads in the screw hole to strip.

**CAUTION!** It is important that the lower stop bolts are properly adjusted to secure the carriage on the track rail. Failure to properly adjust the stop bolts can cause saw head damage, especially during mill transportation.

**CAUTION!** Pressure should not exceed 2000 psi. If it does, the amp draw will rise above the design maximum of 200 amps, and could cause battery and system problems. Pressure above 2000 p.s.i. may also damage the hydraulic hoses.

**CAUTION!** Failure to remove sawdust buildup from the battery box lid and/or track rail cover could result in damage to these parts when the saw head is lowered to its lowest position.

# 1 Safety & General Information

## Sawmill Maintenance

See Table 1-1. Pictogram decals used to warn and inform the user about danger in the LT40.

**TABLE 1-1**





Decal View	W-M No.	Description
	096317	CAUTION! Read thoroughly the manual before operating the machine. Observe all safety instructions and rules when operating the sawmill.
	099220	CAUTION! Close all guards and covers before starting the machine.
	099219	Blade tension. Turning the bolt clockwise will increase the blade tension and turning the bolt counterclockwise will decrease the tension.

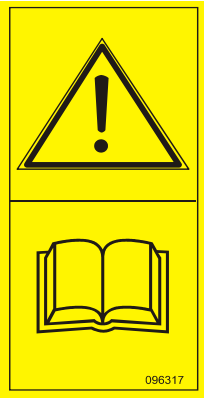

TABLE 1-1

 <p>099223</p>	<p>099223</p>	<p>Blade tension - See manual.</p>
 <p>099221</p>	<p>099221</p>	<p>CAUTION! Keep all persons a safe distance away from work area when operating the machine.</p>
 <p>098176</p>	<p>098176</p>	<p>CAUTION! Keep away from debarker blade!</p>
 <p>099222</p>	<p>099222</p>	<p>CAUTION! Sawdust outlet. Protect eyes!</p>

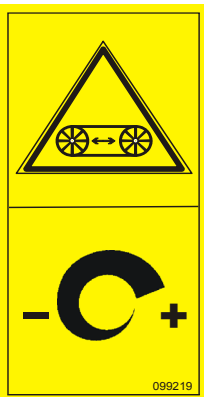
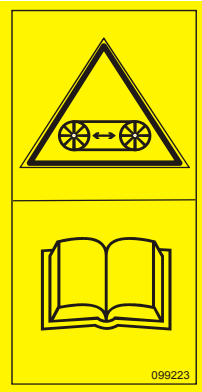
# 1 Safety & General Information

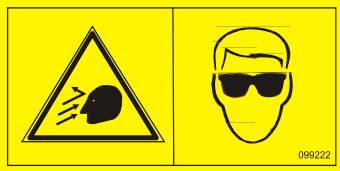
## Sawmill Maintenance

TABLE 1-1









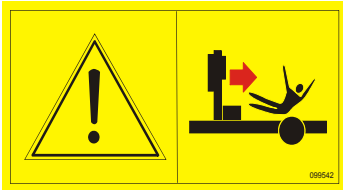

	099542	CAUTION! Trailer.
	086099	CAUTION! Keep away - hot parts!
	096321	Blade movement direction
	S12004G	CAUTION! Always wear safety goggles when operating the sawmill!

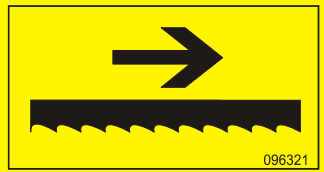
TABLE 1-1

	<p>S12005G</p>	<p>CAUTION! Always wear protective ear muffs when operating the sawmill!</p>
	<p>501465</p>	<p>CAUTION! Always wear safety boots when operating the sawmill</p>
	<p>501467</p>	<p>Lubrication Point</p>
	<p>P11789</p>	<p>Aligning the blade on the wheels</p>
	<p>P85070</p>	<p>CE safety certification</p>

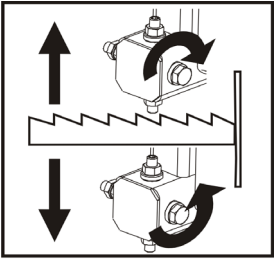
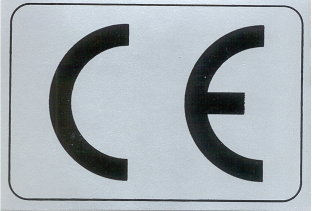
**1** Safety & General Information  
Sawmill Maintenance

**TABLE 1-1**

	099401	Russian safety certification
	S20097B	3300 RPM - Motor rotation direction
	S20097E	2930 RPM - Motor rotation direction

## 1.6 Belt Sizes

See Table 1-2. Belt sizes for the LT40 Series AH are shown.

Description	Belt Size	Wood-Mizer Part #
Blade Pulley Belts	B57 <sup>1</sup>	P04185
Power Feed Drive Belt	AX13X1000	086532
Up/Down Drive Belt	AX23	015257
Board Return Belt	3L190	015477
Motor Drive Belt EA20 & EA25 (50Hz)	3BX73	091548

**TABLE 1-2**

<sup>1</sup> To insure proper blade tracking, use Goodyear, Dayco Super II, or Brown-ing belts only.

# 1 Safety & General Information

## Blade Sizes

### 1.7 Blade Sizes

See Figure 1-3. Wood-Mizer TRU•SHARP™ offers three types of blades to provide efficient sawing for all models of sawmills. The engine/motor size of your sawmill and the type of wood you saw should determine which blade you choose for optimum performance.

	Softwood	Medium Hardwood	Frozen Timber or Dense Hardwood
15-18.5kW (20-25HP) Electric Diesel 42 KM	B376IH1030 B376IH741030	B275IH1030 B275IH741030 B376IH1030 B376IH741030 <sup>2</sup>	B375IH929 <sup>1</sup>

TABLE - 0-0

<sup>1</sup> TRU•SHARP™ “F” blades use a 9/29 profile (9° hook angle and 29° back angle) and are designed to cut frozen and/or extremely dense, hard-to-cut wood. Standard TRU•SHARP™ blades use a 10/30 profile.

See *The Blade Handbook* for blade hook angle, tooth height, and tooth set specifications.

## 1.8 Cutting Capacity

See Figure 1-4. The LT70 Super sawmills can accept logs as listed below.

LT70 Super Sawmill	
Maximum Log Diameter	36,6" ( 93 cm )
Max. Length <sup>1</sup>	20'-2" ( 6.1 m )
Maximum Log Weight <sup>2</sup>	4400 lbs. (1996 kg)

**TABLE - 0-0**

<sup>1</sup> If your sawmill is equipped with a bed extension option, add the length of this extension to the sawmill length capacity (e.g. for BX12 add 12').

<sup>2</sup> Sawmills equipped with bed extensions can accept heavier logs. A load must be distributed uniformly on the frame and bed extension. Maximal weight for BX6 extension is 500kg, for BX12 – 1000kg, for BX24 – 2000kg. Failure to do so may result in machine damage or serious injuries.

# 1 Safety & General Information

## Motor Specifications

### 1.9 Motor Specifications

See Table 1-5. The power options available for the LT40 Series AH. sawmills are listed below.

Model	Manufacturer	Rated output	Current at 380V, 50Hz	Rated speed	Weight
<b>2Sg160M-2B HPS Motor, Tamel</b>	Tamel SA, Poland	15kW (20KM)	28,1 A	2930 RPM	117 Kg
<b>1LA7166-2AA60Z Motor, Siemens</b>	Siemens, Germany	18.5kW (25KM)	33,8 A	2930 RPM	135 Kg

TABLE 1-5

See Table 1-6. The other motors used in sawmills are listed below

Model	Manufacturer	Voltage	Rated output
<b>Power Feed Motor controlled by ALTIVAR (Super)</b>	Besel, Poland	3x380V	1,1 kW, 1380 RPM
<b>Up/Down Motor (2-Speed, Super only)</b>	Besel, Poland	3x380V	0,55/0,9 kW, 950/1400 RPM
<b>Hydraulic Pump Motor (Super only)</b>	Tamel, Poland	3x380V	4 kW
<b>Blade Guide Arm Motor</b>	Motor Products Owosso, USA	12V	17W, 60 RPM

TABLE 1-6

See Table 1-7. The noise level of the motors in Wood-Mizer sawmills.

<b>Sawmill with electric motor</b>	78 dB (A)
------------------------------------	-----------

TABLE 1-7

### 1.10 Overall Dimensions

See Figure 1-8. The overall dimensions of the LT70 sawmills with M frame are listed below.

Sawmill Model	Length <sup>1</sup>	Width <sup>2</sup>	Width (Operating Position with Loading Arms)	Height <sup>3</sup>	Weight	Weight w/Trailer
---------------	---------------------	--------------------	--	---------------------	--------	------------------

TABLE - 0-0



<b>LT70M Super</b>	26' 2" (8 m)	6' 6" (2 m)	8' 2" (2.5 m)	7' 8" (2.4 m)	3491 lbs. (1571 kg)	3916 lbs. (1762 kg)
--------------------	-----------------	----------------	------------------	------------------	------------------------	------------------------

TABLE - 0-0

<sup>1</sup> Length from hitch to chain bracket.

<sup>2</sup> Width from fender to fender.

<sup>3</sup> Height from ground to mast. Placing head in maximum position will add to total height.

### 1.11 Chains

See Table 1-9. The load capacity of the chains is listed below.

	Load Capacity According to ISO Nr 08A-1
Power Feed Chain	1780N
Up/Down Chain	1780N

TABLE 1-9

### 1.12 Hydraulic System

See Table 1-10. The specifications of the hydraulic system are shown below.

Hydraulic Pump	HYDROIRMA
Pressure Rating	15MPa

TABLE 1-10

### 1.13 Components

See **Figure 1-1**. The major components of the Wood-Mizer LT40/70 are shown below.

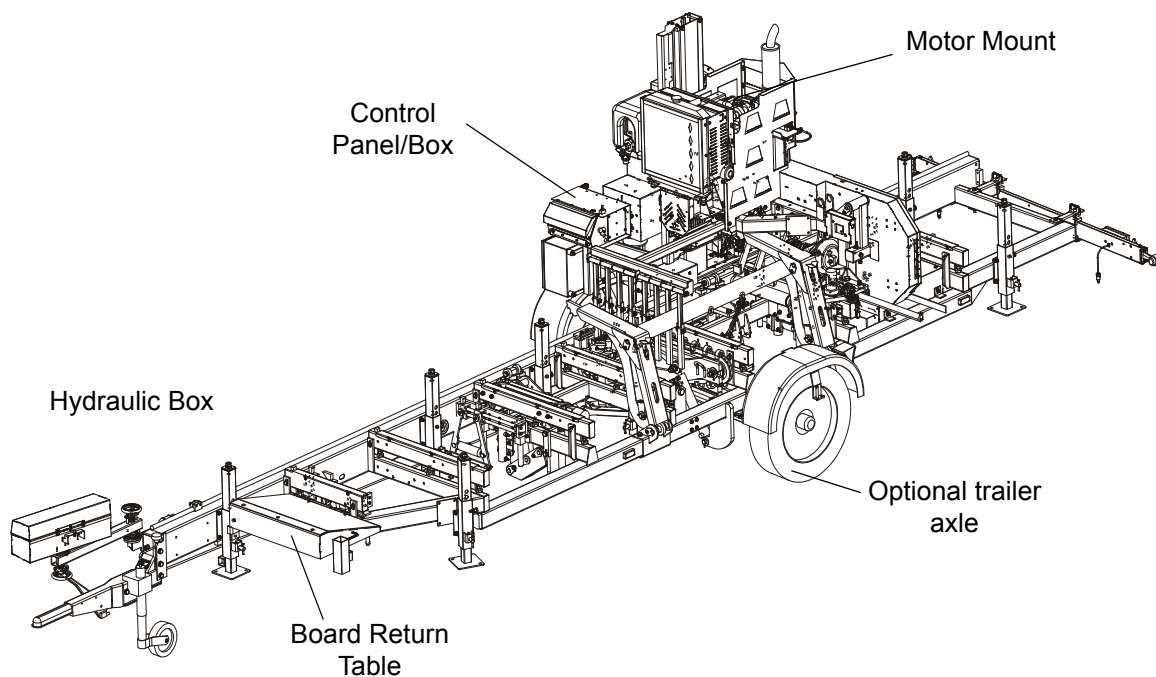

**FIG. 1-1**

1.14 LT40/70 S/M AH Hydraulic Schematic

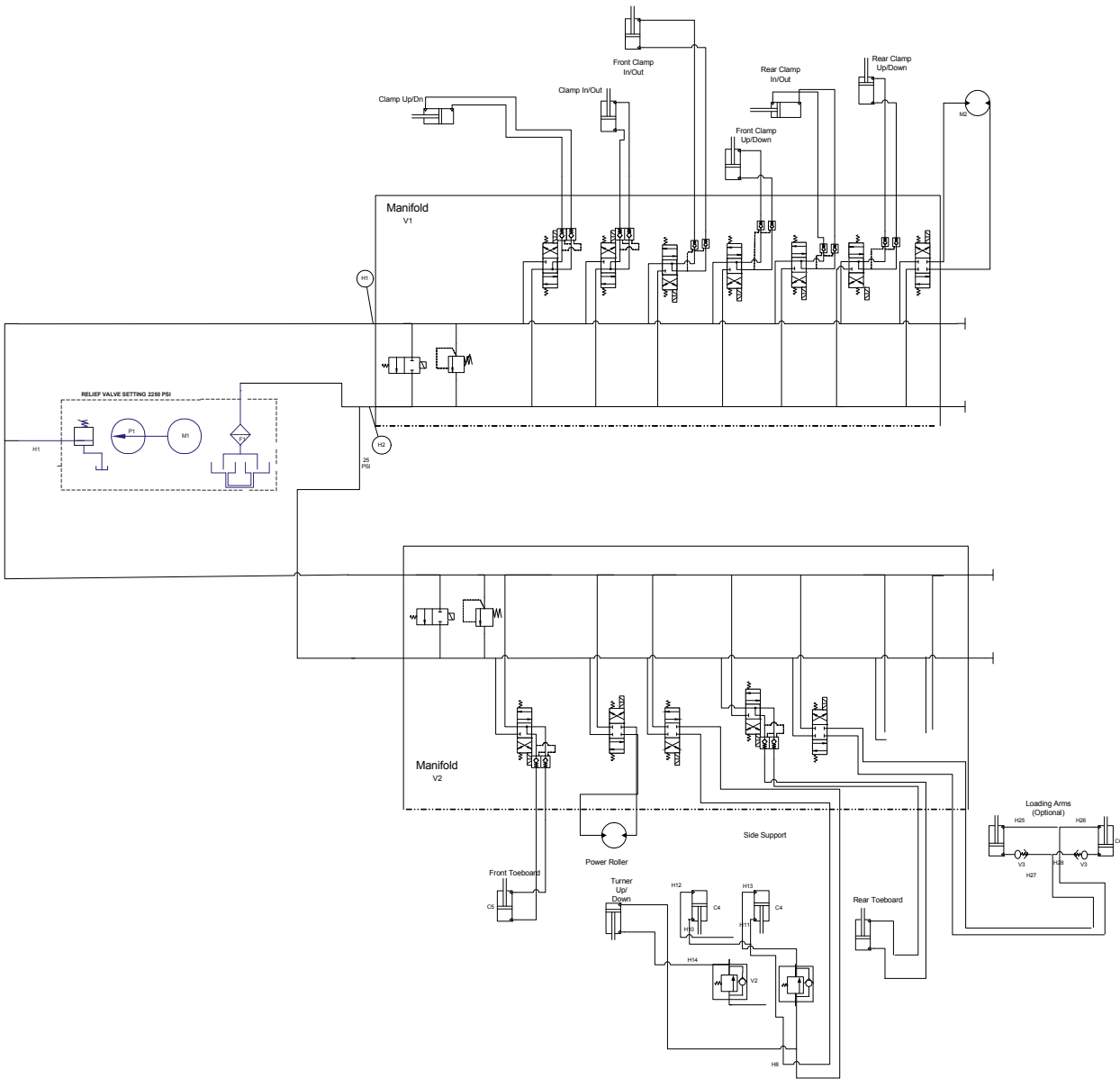

FIG. 1-2 HYDRAULIC SCHEMATIC.

Relief valve setting 2250 PSI -  
Manifold -  
Clamp Up/Down -  
Clamp In/Out -  
Front Clamp In/Out -

# 1 Safety & General Information

## LT40/70 S/M AH Hydraulic Components

Front Clamp Up/Down -  
 Rear Clamp In/Out -  
 Rear Clamp Up/Down -  
 Front Toe Board -  
 Power Roller -  
 Turner Up/Down -  
 Side Support -  
 Rear Toe Board -  
 Loading Arms (optional) -

### 1.15 LT40/70 S/M AH Hydraulic Components

ID	Mfg. Part No.	Manufacturer	Wood-Mizer Part #	Description
C1	015090	J-D Hydraulic	017275	Hyd. Cylinder, 3" Bore x 7 7/8" Stroke
C2	PMC-19410	Prince Mfg.	015053	Hyd. Cylinder, 1 1/2" Bore x 10" Stroke
C3	P12846	J-D Hydraulic	P12846	Hyd. Cylinder, 2 1/2" Bore x 8" Stroke
C4	P12845	J-D Hydraulic	P12845	Hyd. Cylinder, 2" Bore X 6" Stroke
C5, C6	014482	J-D Hydraulic	014482	Hyd. Cylinder, 1 1/2" Bore x 6" Stroke
C7, C8	P12847	J-D Hydraulic	P12847	Hyd. Cylinder, 3" Bore X 8" Stroke
M1, P1	---	Hydromar, Szamotuly	086789	Hydraulic Unit (Container + Hydraulic Pump + Motor), 14.5 l/min.
V1	HDS11/6-6	Betro Inc.	015260	Valve, 6-Handle
V2, V3	49004-700	Vonberg	015484	Sequence Valve
V4, V5	28000-502-2.5	Vonberg	015750	Valve, Hydraulic Velocity Fuse
F1	S28	Hyd. Filter Supply	P20301	Filter, Hydraulic Fluid Cartridge

TABLE - 0-1

[See Section 9.1](#) LT70 Super Parts List.

This manual is to replace or to be used with all previous information received on the Wood-Mizer®\* sawmill. All future mailings will be an addition to or a revision of individual sections of this manual as we obtain new information.

The information and instructions given in this manual do not amend or extend the limited warranties for the equipment given at the time of purchase.

#### ***If You Need To Order Parts...***

From Europe call our European Headquarters and Manufacturing Facility in Kolo, Poland at **+48-63-2626000**. Please have the vehicle identification number and your customer

number ready when you call. Wood-Mizer will accept these methods of payment:

- Visa, Mastercard, or Select Purchase
- COD
- Prepayment
- Net 15 (with approved credit)

Be aware that shipping and handling charges may apply. Handling charges are based on size and quantity of order. In most cases, items will ship on the day they are ordered. Second Day and Next Day shipping are available at additional cost.

***If You Need Service...***

From Europe call our European Headquarters and Manufacturing Facility in Kolo, Poland at **+48-63-2626000**. Ask to speak with a Customer Service Representative. Please have your vehicle identification number and your customer number ready when you call. The Service Representative can help you with questions about alignment of your mill, blade sharpening, or cutting a particular species of wood. He also can schedule you for a service call.

**Office Hours:** All times are Eastern Standard Time. Please remember that Indiana does not go on Daylight Savings Time in the summer.

Country	Monday - Friday	Saturday	Sunday
U.S., Indiana	8 a.m. to 5 p.m.	8 a.m. to 4 p.m.	Closed
Poland	8 a.m. to 4:30 p.m.	8 a.m. to 1 p.m.	Closed



**IMPORTANT!** Read the entire Operator's Manual before operating the sawmill. Take notice of all safety warnings throughout this manual and those posted on the machine. Keep this manual with this machine at all times, regardless of ownership.

\*Wood-Mizer® is a registered trademark of Wood-Mizer Products, Inc.

# 1 Safety & General Information

## LT40/70 S/M AH Hydraulic Components

---

### Sawmill and Customer Identification

Each Wood-Mizer sawmill has a 17-digit Vehicle Identification Number (VIN). See the figure below for VIN locations. See the chart for VIN description.



**V.I.N. LOCATIONS**

	Company Identification Number 456=Wood-Mizer Indiana	Weight Class; A=Under 1361 kg, B=1361-1814 kg, C=1814-2268 kg, D=2269-3000kg	Product No.; 1=LT15, 2=LT20, 4=LT40 Series, 7=LT70 Series	Length of the Trailer; 20=20 Ft., 24=24', 35=35'	Number of axles on the trailer	Check Digit Add all the number and divide by 11	Year of Manufacture; G=2009, H=2010, J=2011, K=2012, L=2013, M=2014	State of Manufacture N=Indiana, P=Poland	Month of Manufacture A=January, B=February, C=March, etc...	Revision Level	Sequence Number Ranging from 000-999	End of 17-Digit VIN	Revision Level (Repeated)	Two-Digit Minor Revision Level
<b>456</b>	<b>A</b>	<b>4</b>	<b>24</b>	<b>1</b>	<b>X</b>	<b>J</b>	<b>N</b>	<b>A</b>	<b>F9</b>	<b>017</b>	<b>F9</b>	<b>.01</b>		

**V.I.N. DESCRIPTION**

Each sawmill is also identified with a model number which includes the base model and the engine/motor configuration. See the figure for a description of the model number.

**LT40**  
Basic Sawmill I.D.

**E25**  
Engine/Motor  
Configuration

**MODEL NUMBER DESCRIPTION.**

When you pick up your mill, you will receive a customer number. Both the VIN and your customer number expedite our service to you. Please write these numbers below so you have quick, easy access to them.

Customer No.	Model No.	V.I.N.	Revision

## SECTION 1 SETUP & OPERATION

### 1.1 Sawmill Setup



**IMPORTANT!** Before starting to use the sawmill you have to meet the following conditions:

- Set up the sawmill on firm and level ground.
- The sawmill can be operated with the sawdust collection system only.
- The sawmill can be operated under roof only.
- The sawmill can be operated in temperature range from -15° C to 40° C only.
- Illuminance at operator's position must be 300lx.
- The sawmill operator's position is shown below.

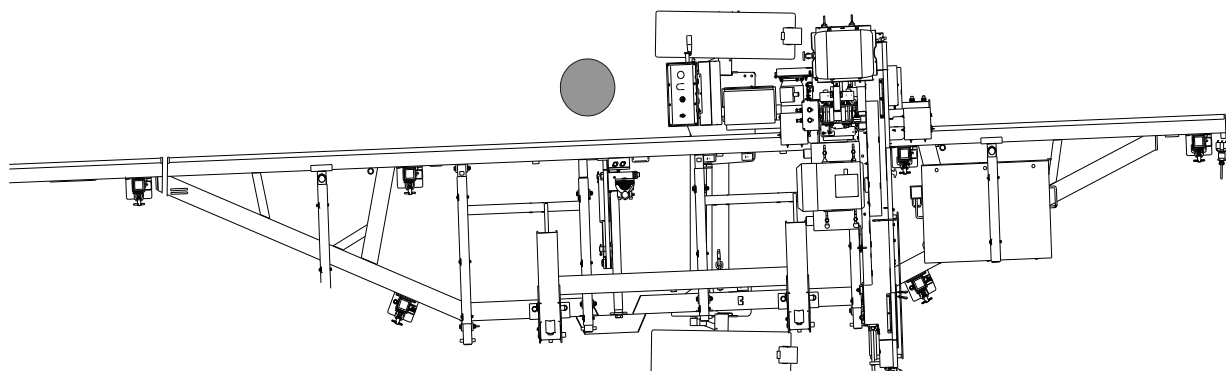

- Have a qualified electrician install the power supply (according to EN 60204 Standard). The power supply must meet the specifications given in the table below.

3-Phase Volts	Fuse disconnect	Suggested Wire Size
400 VAC	40 A	6 mm <sup>2</sup> up to 15 m long

**TABLE 1-0**





**IMPORTANT!** When starting the machine for the first time, check that main motor rotation direction is as indicated by the arrow located on the motor body (fan guard). If the rotation direction is incorrect, invert the phases in the phase inverter in the power socket (electric box). Setting the phases in the phase inverter correctly will ensure correct



rotation directions of all sawmill motors.

## 1.2 Stationary Sawmill Setup

Set up the mill on firm footing and level by eye. Fasten the mill to the floor to prevent any creep after prolonged use. Overall Dimensions- See Tabela 1-8 na stronie 14.

1. Unlock hydraulic control box by pulling out locking pin from the control box blockade. Remove the control box blockade from the saw head track rails.
2. Unhook the carriage safety chain, located at the bottom of the vertical mast, near battery box.
3.  Turn the key switch on the control panel to the accessory position ACC (#3), to enable the battery-operated accessories. Use the up/down switch on the control panel to raise the cutting head from the carriage rest pin. Remove the locking pin and swing the rest pin down below bed level.
4.  Turn the key switch on the control panel to the accessory position. Use the up/down switch on the control panel to raise the cutting head from the carriage rest pin. Remove the locking pin and swing the rest pin down below bed level.
5. Use the carriage fwd/rev switch (left side of control box) to move the cutting head toward the front end of the mill. The hydraulic control levers become operational when the contacts at the bottom of the carriage touch the power strip on the frame tube. The hydraulic control levers will only work when the cutting head is close enough to the front end of the mill to touch the power strip.
6. Raise the side supports that will prevent a log from falling off the side of the mill when loaded.

See Figure 1-1.

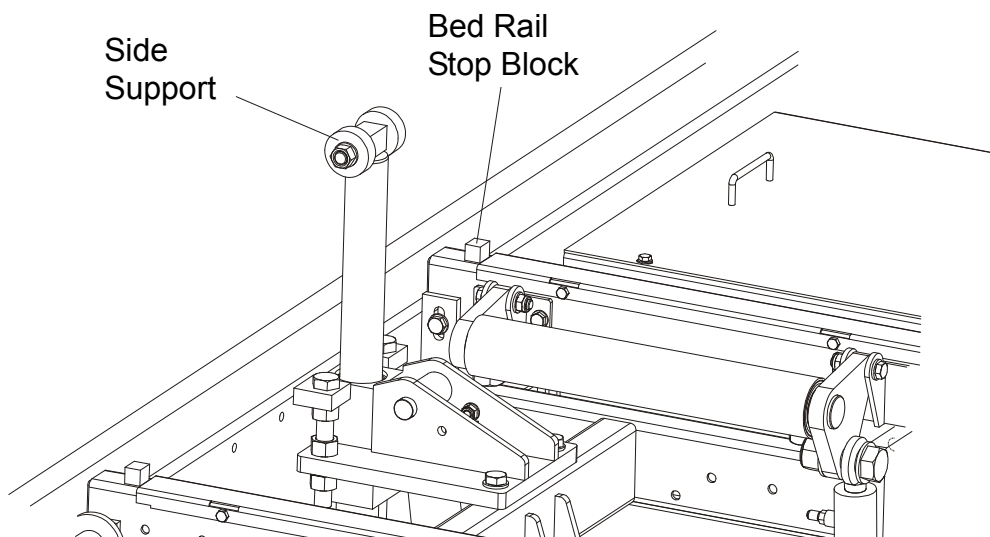

**FIG. 1-0**

### **1.2.1** *Sawmills with cable guide*

**See Figure 1-2.** The figure below shows setup of the sawmill, the control box and the guiding rail columns.

Secure the columns to the ground using 16mm anchored bolts.

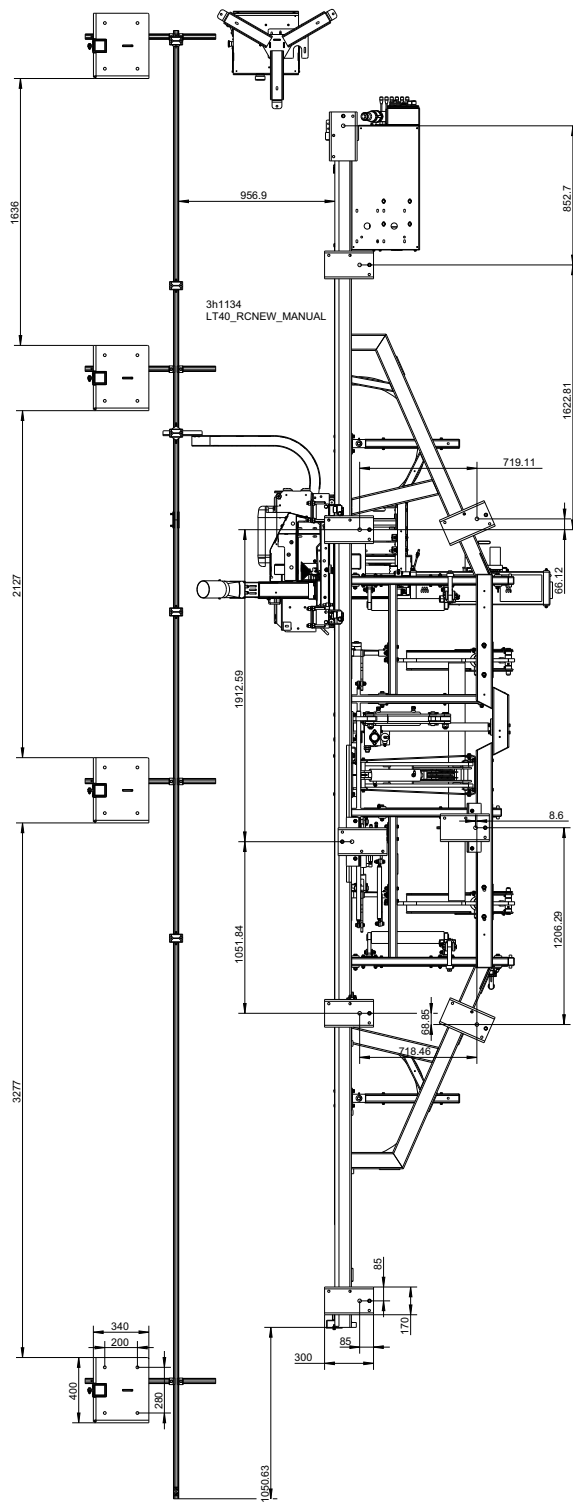

FIG. 1-3 LT40MRC

# 1 Setup & Operation

## Sawmills with cable guide

See Figure 1-4. The electrical wires should be installed on the guiding rail as shown below.



FIG. 1-5

See Figure 1-2. Install the rail bracket arm as shown below.

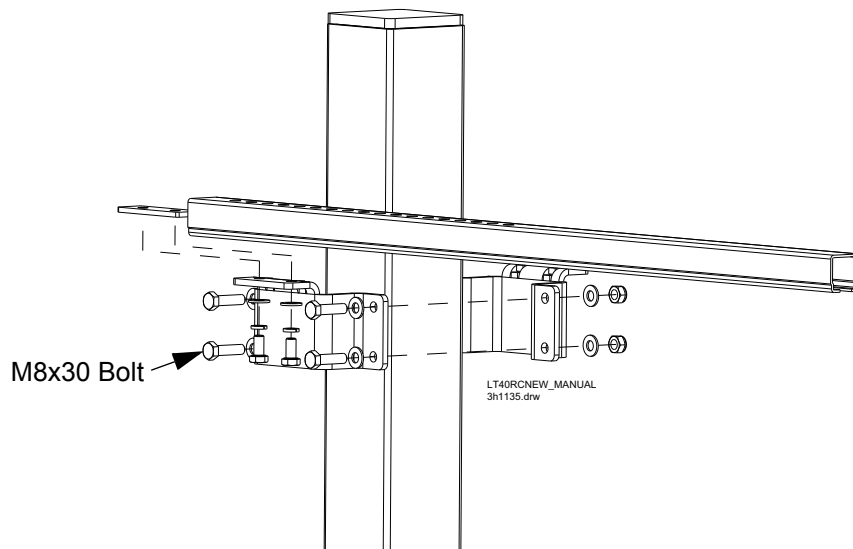

FIG. 1-6

See Figure 1-3. Install the guiding rail.

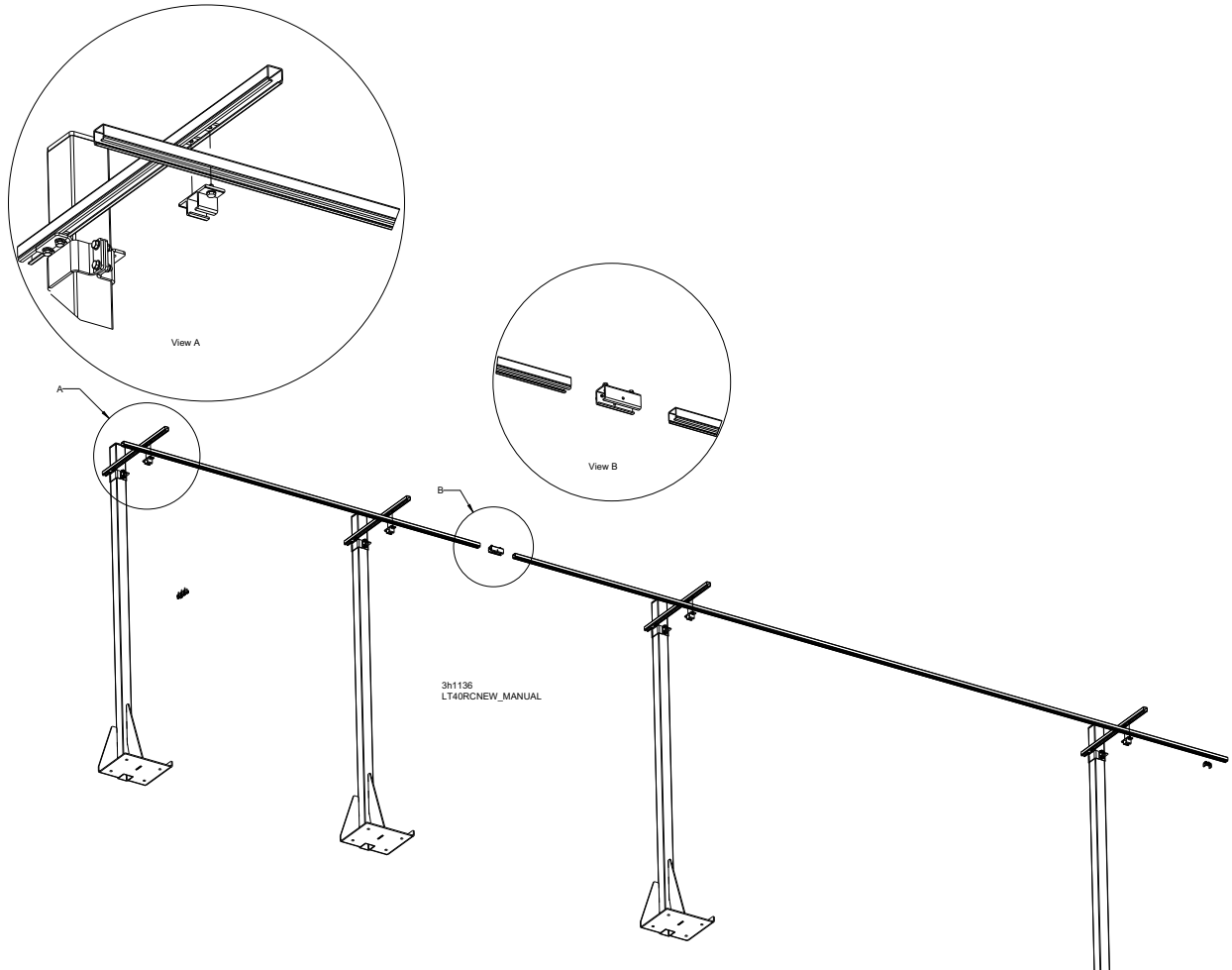

FIG. 1-7

See Figure 1-8.

# 1 Setup & Operation

## Sawmills with cable guide

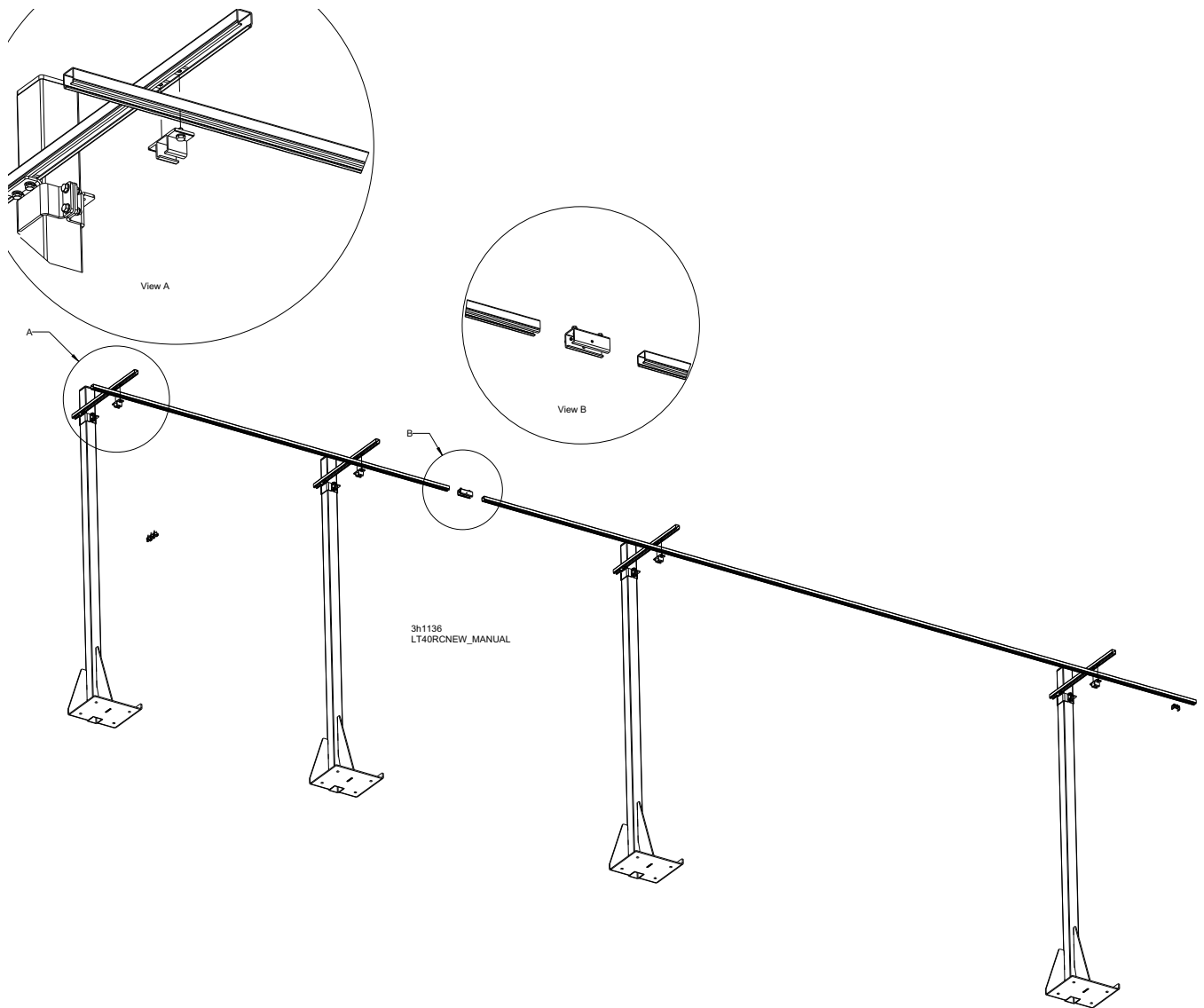

FIG. 1-9

## 1.3 Portable Sawmill Setup



**WARNING!** Do not set up the mill on ground with more than a 10 degree incline. If setup on an incline is necessary, put blocks under one side of the mill or dig out areas for outrigger legs to keep mill level. Setting up the mill on an incline could cause it to tip over, resulting in serious personal injury.

**WARNING!** Chock the trailer wheels to prevent movement before unhitching it from the towing vehicle. Failure to do so will result in serious injury or death.

**WARNING!** Always make sure the trailer is supporting the sawmill frame when operating a sawmill with adjustable outriggers. Failure to do so will result in serious injury or death. The adjustable outriggers are intended to support the saw frame with assistance from the trailer.

1. Unhitch the mill from the vehicle.
2. Lower and set the front outriggers. To lower the leg, first place a 19 socket wrench on the outrigger adjustment bolt and turn the bolt until the outrigger movable part reaches its highest position. Next pull the locking pin out of the outrigger hole. When the outrigger contacts the ground, release the pin. Then place a 19 socket wrench on the outrigger adjustment bolt and turn the bolt until the locking pin enters the nearest outrigger hole.



**WARNING!** Put front outrigger down before moving cutting head from the rest position. Failure to do so may result in serious injury.

See Figure 1-10.

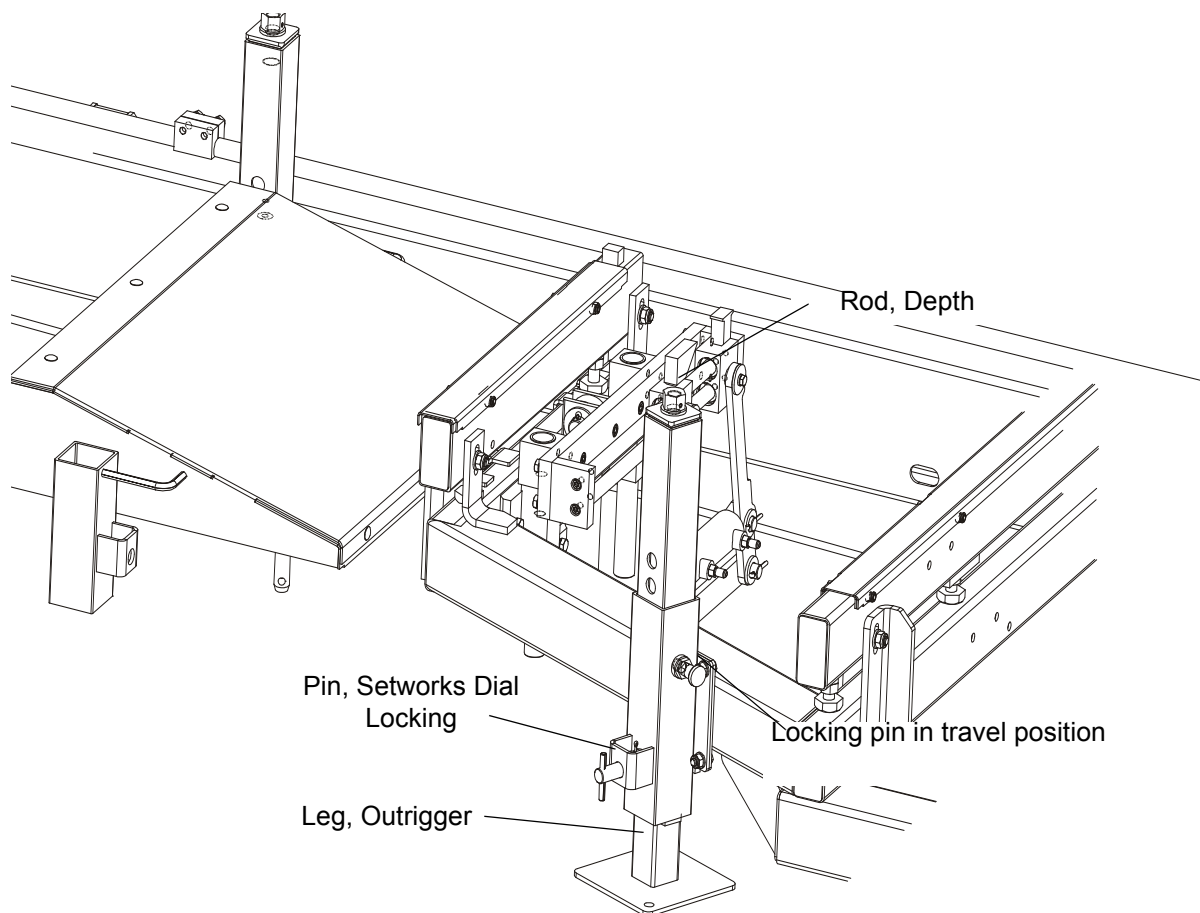

**FIG. 1-3. OUTRIGGER ADJUSTMENT**

3. Unhook the carriage safety chain, located at the bottom of the vertical mast.



4. Turn the key switch on the control panel to the ACC (#3)(#1) position, to enable the battery-operated accessories. Use the up/down switch on the control panel to raise the cutting head from the carriage rest pin. Remove the locking pin and swing the rest pin down below bed level.

5. Remove the fenders by lifting them out of the slots.



**CAUTION!** To prevent fender damage, remove fenders before operating sawmill or loading logs.



6. Use the carriage fwd/rev switch (left side of control box) to move the cutting head toward the front end of the mill. Lower and set the remaining rear outriggers.

7. Level the sawmill by adjusting the outriggers to raise or lower each end of the sawmill. Adjust all outriggers evenly to avoid twisting the mill frame by jacking one outrigger higher than the others.

Raise the side supports to prevent the log from falling off the side of the mill when loaded.



See Figure 1-11.

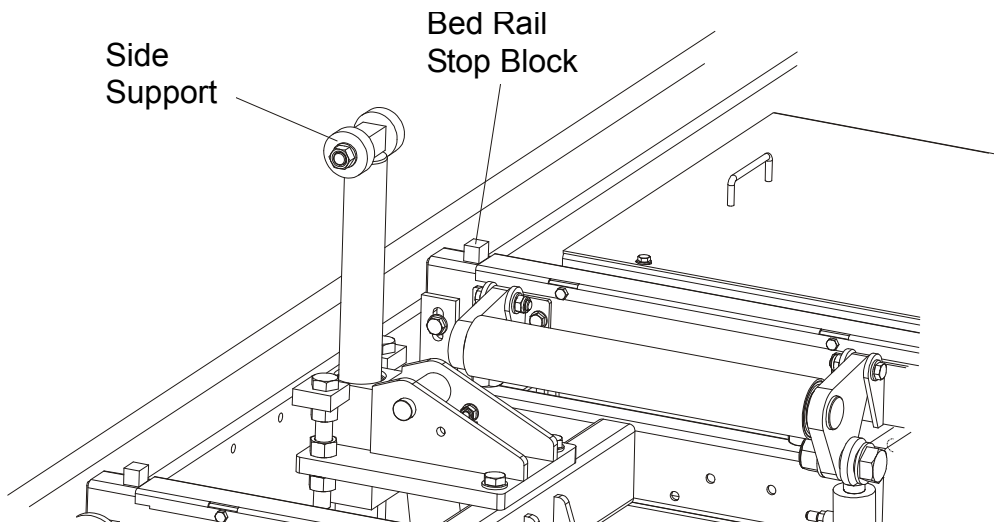

**FIG. 1-3**

### 1.4 Middle Track Cover

Before operating the sawmill do as follows:

1. Clean the upper and lower rails to remove any sawdust and rust preventives.
2. Unbolt and remove the middle track cover from its storage position.
3. Soak the felt wiper with Dexron III transmission fluid, 10W30 motor oil or 3-in-1 turbine oil.
4. Install the middle track cover so it fits against the rail and secure with two thumb screws.

See Figure 1-4.

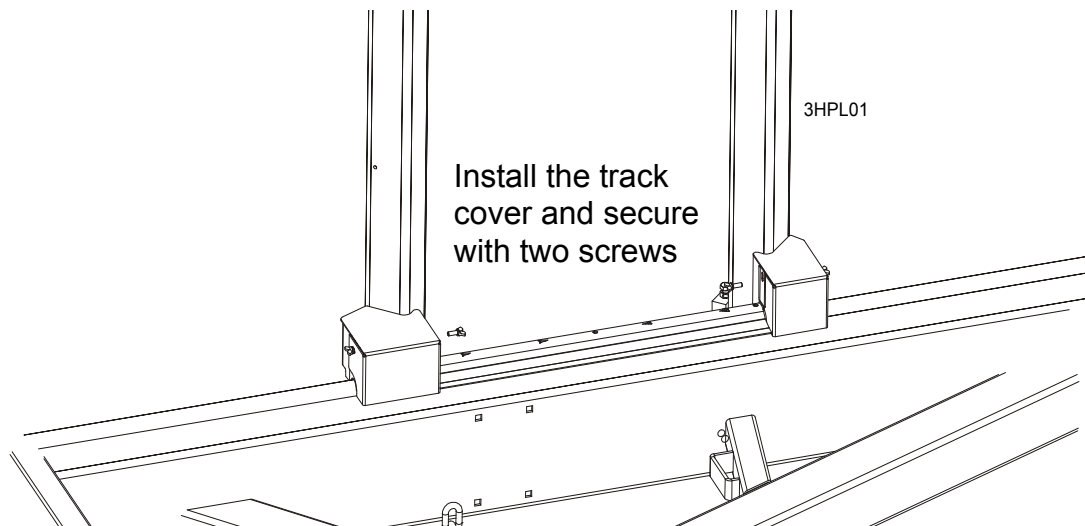

FIG. 1-4



**CAUTION!** Install the track cover so that it lightly touches the track rail. If the wiper presses too firmly against the rail, it can cause the power feed to bind.

## 1.5 Replacing The Blade



**DANGER!** Always disengage the blade and shut off the sawmill engine before changing the blade. Failure to do so will result in serious injury.



**WARNING!** Always wear gloves and eye protection when handling bandsaw blades. Changing blades is safest when done by one person! Keep all other persons away from area when coiling, carrying or changing a blade. Failure to do so may result in serious injury.

Remove the two main blade housing covers that cover the blade wheels. Lower the hinged middle blade housing cover. Turn the blade tension handle to release the blade tension until the wheel is pulled in and the blade is lying loose in the blade housing. Lift the blade out of the blade housing.

When installing a blade, make sure the teeth are pointing the correct direction. The teeth should be pointing toward the operator side of the mill when you are looking at the blade below the blade guides. Install the blade so it is lying around the wheels.

Position 1 1/4" wide blades on the wheels so the gullet is 1/8" (3.0 mm) out from the edge of the wheel. Position 1 1/2" wide blades on the wheels so the gullet is 3/16" (4.5 mm) out from the edge of the wheel.

Close the middle blade housing cover.

Next, turn the tension handle until the blade is tensioned correctly.

## 1.6 Tensioning The Blade

See Figure 1-5. Tension the blade by turning the hydraulic tensioning handle clockwise until the tension gauge indicates the recommended tension.

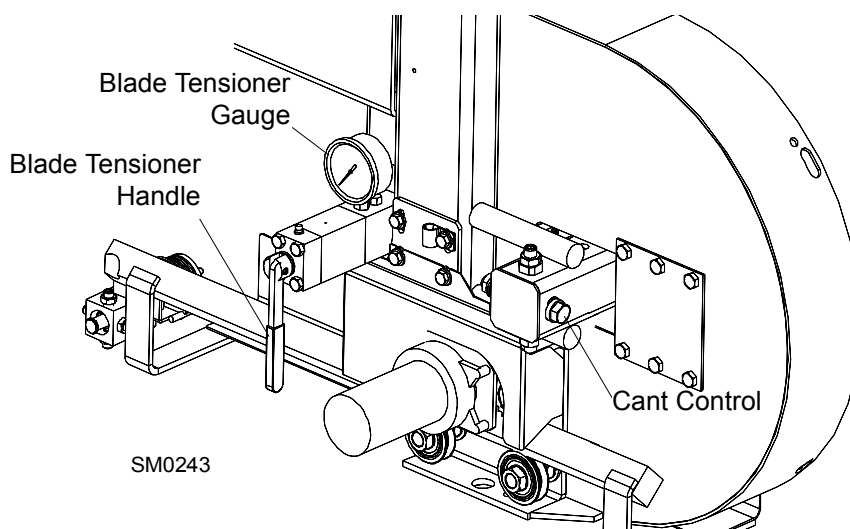

FIG. 1-5

See Table 1-12. The recommended tension for different blades is shown below.

Blade Type	Acceptable Range	Ideal Tension
B375IH929	12,4 - 14,5 MPa (1800 - 2100 psi)	13,8 MPa (2000 psi)
B275IH1030	14,5 - 16,5 MPa (2100 - 2400 psi)	15,9 MPa (2300 psi)
B275IH741030	14,5 - 16,5 MPa (2100 - 2400 psi)	15,9 MPa (2300 psi)

TABLE 1-12

The tension gauge should be checked occasionally when adjusting the cant control or while cutting. Ambient temperature changes will cause tension to change. Adjust the tension handle as necessary to maintain the recommended tension level.

**CAUTION!** Changes in temperature could cause increased pressure in the blade tensioner and loss of fluid from the gauge. Release the blade tension when the mill is not in use to avoid damage to the tensioner.

## 1.7 Tracking The Blade

1. Make sure the middle blade housing cover is closed and all persons are clear of the open side of the saw head.
2. Start the motor by pushing the START button located on the control box.



**WARNING!** Do not spin the blade wheels by hand. Spinning the blade wheels by hand may result in serious injury.

3. Push the STOP button to stop the blade. Remove the key and check the position of the blade on the blade wheels.

**See Figure 1-6.** Position 1 1/4" wide blades so the gullet is 3.0 mm (0.12") out from the edge of the blade wheel ( $\pm 1.0$  mm [0.04"]). Position 1 1/2" blades so the gullet is 4.5 mm (0.18") out from the edge of the blade wheel ( $\pm 1.0$  mm [0.04"]).

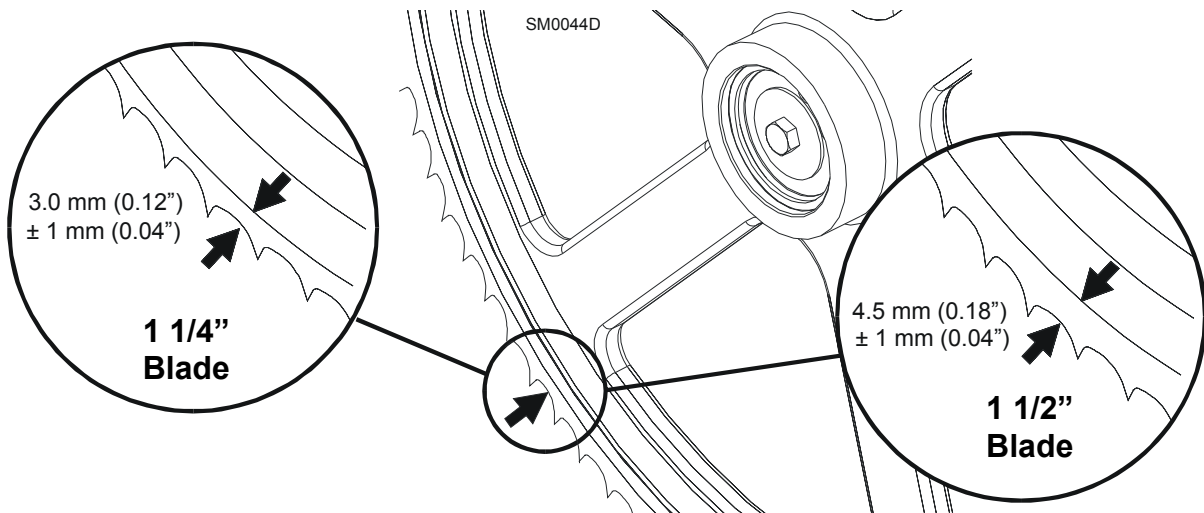

FIG. 1-6

4. To adjust where the blade travels on the blade wheels, use the cant control shown in **Figure 1-5**.

If the blade is too far out, back the blade onto the wheel by turning the cant control counterclockwise. If the blade is too far in, turn the cant control clockwise until the gullet of the blade is the correct distance from the front edge of the wheel.

5. Retension the blade to the recommended tension to compensate for any adjustments you have made in the cant control.
6. Replace the blade housing covers.



**DANGER!** Make sure all guards and covers are in place and secured before operating or towing the sawmill. Failure to do so may result in serious injury. Be sure the blade housing and pulley covers are in place and secure. Use the safety retainer pin and cable to fasten blade

housing covers.

**IMPORTANT!** After aligning the blade on the wheels, always double-check the blade guide spacing and location. (See Section 5 for more information.)

## 1.8 Starting The Motor

See the appropriate manual supplied with your specific motor configuration for starting and operating instructions.



**DANGER!** Make sure all guards and covers are in place and secured before operating or towing the sawmill. Failure to do so may result in serious injury. Be sure the blade housing and pulley covers are in place and secure. Use the safety retainer pin and cable to fasten blade housing covers.

**DANGER!** Check the sawmill wiring every year. Make sure all electrical installation, service and/or maintenance work is performed by a qualified electrician.

**DANGER!** Do not operate or leave the sawmill with the electrical boxes open. Failure to do so may cause serious injury or death.



**WARNING!** Always wear eye, ear, respiration, and foot protection when operating the sawmill. Failure to do so may result in serious injury.

**WARNING!** Be sure the power feed switch is in the neutral position before turning the key switch to the (#1) or (#2) position. This prevents accidental carriage movement, which may cause serious injury or death.

**WARNING!** Hazardous voltage inside the electric box is dangerous. Turn the main switch to the OFF ("0") position and lock out power supply before opening the box door!

**WARNING!** Hazardous voltage inside the electric control box attached to the hydraulic control box is dangerous. Turn the main switch to the OFF ("0") position and lock out power supply before opening the box door!

**WARNING!** The door of the electric box can be opened only when the main switch is in the "0" position. The door is closed when the switch is in the "1" position. Serious damage to the box may result while opening the door when the main switch is in the "1" position.

At least once a year the electric wires should be checked for isolation and hazardous voltage by a qualified person.

Keep the electrical starter box clean. Remove any dust or wood chips from the box from time to time. Make sure the electric box door is closed before operating the sawmill.

**WARNING!** Hazardous voltage inside the electric box and inside the motor can cause shock, burns, and death. Turn the main switch to the OFF ("0") position and lock out power supply before opening the box door!

The time-delay relay in the electrical starter box attached to the hydraulic box should be set between 4 and 5 seconds.

After installation, test the sawmill for proper motor rotation.

If rotation is incorrect, turn the motor off pushing the STOP button located on the control box. Turn the main switch on the starter box to the OFF ("0") position. Disconnect the power cord on the left side of the starter box.

Use the screwdriver to turn the phase converter switch to the left or to the right to change the motor rotation.



## 1.9 Board Return

 **WARNING!** The automatic board return is intended to assist a second operator in removing boards quickly. Do not use the board return when operating the sawmill alone. Serious injury, death or damage to the equipment may result.

 **WARNING!** Never use the board return table as a platform to stand on. This table is designed and intended to assist in the removal of boards only. Standing on the table may result in serious injury.

Super sawmill models are equipped with a board return system. This system consists of an arm on the saw head controlled by a toggle switch on the control panel. A board return table is also provided to catch the board as it is removed from the log.

To install the board return table, remove the two pins securing it in its storage position at the rear of the sawmill.

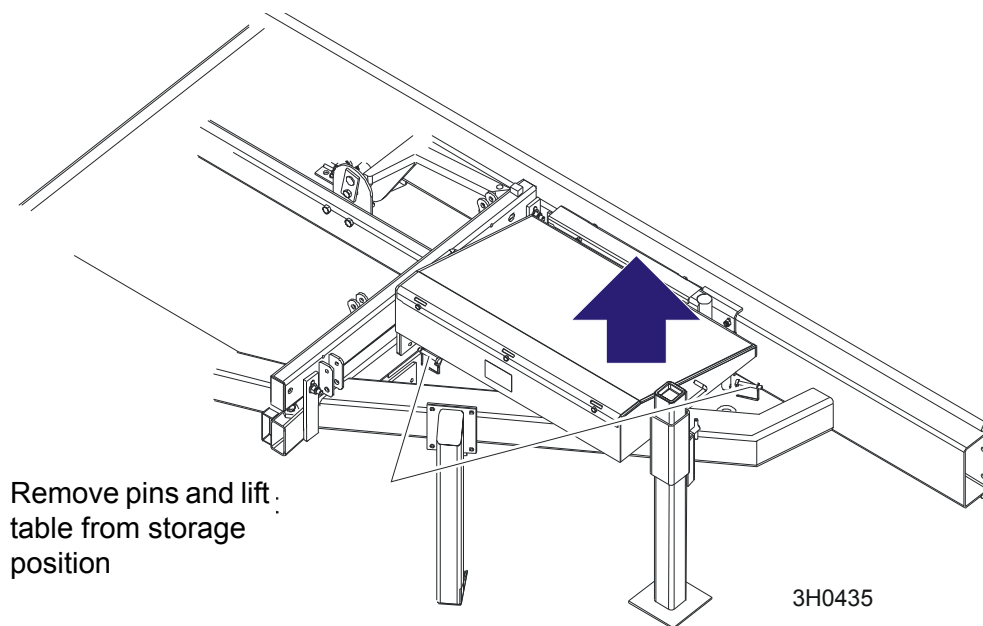

**FIG. 1-6**

# 1 Setup & Operation

## Board Return

Install the table at the front of the sawmill bed with the outrigger toward the loading side of the sawmill.

**See Figure 1-7.** Be sure the edge of the table seats in the slot on the bed frame and the table tab seats in the leg bracket. Lower the outrigger and adjust it until it is firmly planted on the ground.

Store the pins by placing one pin in the hole under the table. Loop the second pin through the retainer of the first pin and lock.

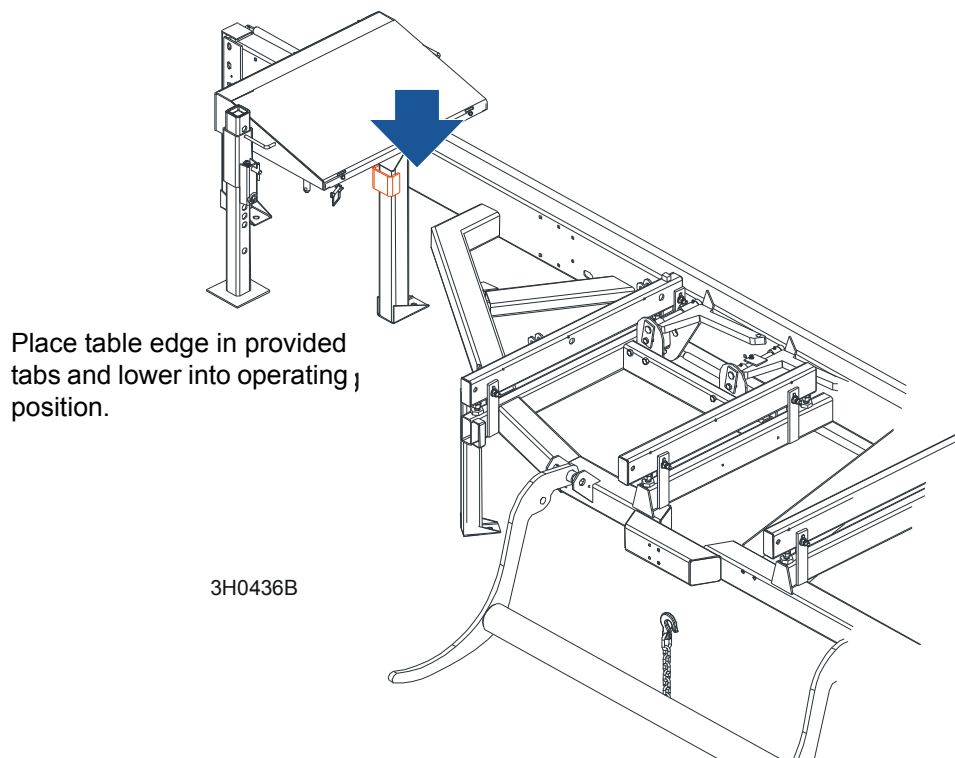

**FIG. 1-7**



To activate the board return, turn the key switch to the #1 position. Push the toggle switch on the control panel down. The board return arm located in the middle of the saw head will drop into position.

See Figure 1-8.

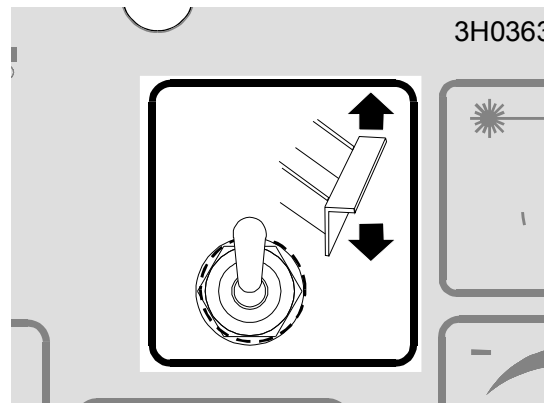

FIG. 1-8

When the blade reaches the end of the log, the arm will drop down to catch the board and drag it back toward the operator as the saw head is returned.



**DANGER!** Keep all persons out of the path of returning boards. Failure to do so will result in serious injury.

Boards may not always return in the same path or location. If a board returns in a manner that does not allow the sawyer or off-bearer to maintain control, it may be necessary to stop the reverse motion of the saw head.

When the board return is to be used, a second person is required to remove the board as it is returned. DO NOT attempt to use the board return feature when sawing alone.

To bypass the board return feature, push the toggle switch on the control panel up.

When done sawing, return the board return table to its storage position and secure with both locking pins. Adjust the outrigger leg up to provide proper ground clearance when towing the sawmill.



**WARNING!** To avoid damage to the board return table, secure it in its storage location before towing the sawmill.

## 1.10 Hydraulic Control Operation

The hydraulic control levers become operational when the contacts at the bottom of the carriage touch the power strip on the frame tube. The hydraulic control levers will only work when the cutting head is close enough to the front end of the mill to touch the power strip.

See Figure 1-13. Sawmills equipped with A/DHS7 hydraulic system have fourteen control levers to load, clamp, turn and level logs.

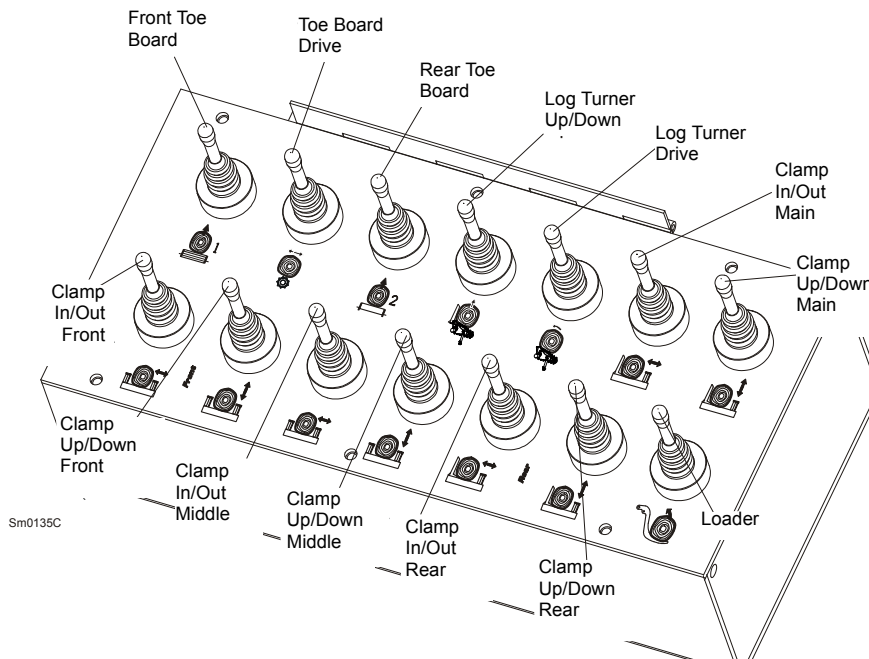

FIG. 1-8

Use the hydraulic control levers to get the mill ready to load a log.

**DANGER!** Keep all persons out of the path of moving equipment and logs when operating sawmill or loading and turning logs. Failure to do so may result in serious injury.

**CAUTION!** Always make sure the engine is running before operating the hydraulic controls. Operating the controls without the engine running will result in power drainage from the battery. Holding the hydraulic switches halfway up or down also will cause excessive drainage from the battery.

1. Move the clamp out and down so it will not get in the way of logs being loaded onto the bed.



Lower the clamp in/out lever to move the clamp out toward the loading side of the sawmill.



Lower the clamp up/down lever to lower the clamp below bed level.

2. Raise the log loader lever to extend the legs of the log loader out as far as they will go .



3. The chain securing the log loading arm to the log turner arm will be tight. Raise the log turner lever to raise the turner arm until there is slack in the chain.
4. Unchain the loading arm from the turner arm.
5. Manually lower the log loader so the legs rest on the ground.



**CAUTION!** Be careful when manually lowering the log loader. Do not drop the loader onto the ground.

6. Lower the loader lever to lower the loading arm as far as it will go. Logs must be rolled onto the loading arm one at a time for loading onto the bed of the mill.



7. The front and rear toe boards should be below bed level. Once a tapered log has been loaded, the front or rear end of the log may be lifted to parallel the heart of the log to the path of the blade.



The front toe board is raised by lifting the front toe board lever up. The rear toe board is raised by lifting the rear toe board lever up. Once a flat has been made and the log is ready to be turned, push the appropriate toe board lever down to lower either toe board until it falls below the level of the bed.

Use the power roller to move the log forward and backward.



## 1.11 Loading, Turning, And Clamping Logs



**CAUTION!** Be sure the pivot rails, turning arm, clamp, and toe boards are below bed level before loading a log onto the bed. Failure to do so may result in machine damage or cause misalignment.

### To Load Logs

1. Move a log up to the loading arm. Use cant hooks or loading equipment to move the logs to the foot of the loading arms.
2. Roll the log onto the loader so that it is approximately centered with the sawmill bed. The log turner will operate much easier if the log is centered on the sawmill bed.
3. Raise the loader lever to raise the log onto the sawmill bed. Simply let the loader rise until the log rolls onto the mill bed.



4. Lower the loading arm. Leave the loading arm about halfway up while squaring the log. This will stop the log from rolling off the side of the mill.



**WARNING!** Always leave loading arm halfway up while log is on sawmill bed. Failure to do so may result in serious injury or death.

**NOTE:** Logs also may be loaded onto the mill with a tractor or other equipment specifically designed for that purpose.

5. Raise the clamp up to prevent the log from rolling off the bed.
6. Raise the clamp up/down lever.



### To Turn Logs

1. Raise the turner lever to engage the log turner arm. Let the arm rise until it touches the log and starts to turn it.



2. Spin the log against the side supports until it is turned the way you want it for the first cut. If you want to turn the log more, do the following steps.

3. Engage the clamp by raising the clamp in/out lever. Clamp the log against the side supports.



Lower the turner lever to lower the turner arm below the log.



5. Raise the turner arm to get a new bite on the log.
6. Disengage the clamp.
7. The log can be turned now. Repeat steps 4 through 7 until the log is turned as desired.

### To Turn Logs (Optional Procedure For Hydraulic Mills Except Only)

If you are turning a small cant on a Super Series mill, you may opt to use the clamp to turn the cant.

1. Lower the clamp up/down lever to lower the clamp below bed level.
2. Raise the clamp in/out lever to move the clamp in, beneath the edge of the cant.
3. Raise the clamp up/down lever to raise the clamp and flip the cant.

**To Clamp Logs**

1. Raise the clamp in/out lever and clamp the log against the side supports.



2. Lower the turner lever until the turner arm falls below the bed.



3. When the turner arm is lowered all the way, the side supports will begin to lower. Back the clamp off slightly, and let the side supports come down until they are positioned below the level of your first few cuts.

**To Level A Tapered Log**

Use the toe board lever(s) to raise either end of a tapered log, if desired.



Raise the appropriate lever to raise the front or rear toe board until the heart of the log measures the same distance from the bed rails at each end of the log.

***Pull-Down Clamps***

When a cant is being cut, internal stress in the wood may cause the cant to deform slightly. The cant with internal stress tends to raise on ends. To prevent this, use two additional Pull-Down clamps. These clamps are mounted at both bed frame ends and if necessary hold the cant down so it lies flat on the bed.



## 1.12 Up/Down Operation

1. Install a blade, if needed, and check for correct blade tension. ([See Section 1.6](#)).
2. Set the cutting head to the desired height. (The blade height scale shows the height of the blade above the bed rails.)



**See Figure 1-9.** The up/down switch is located on the far right side of the control panel. Push the switch up to raise the cutting head; push the switch down to lower the cutting head. Hold the switch in position until the cutting head reaches the desired height, then release.

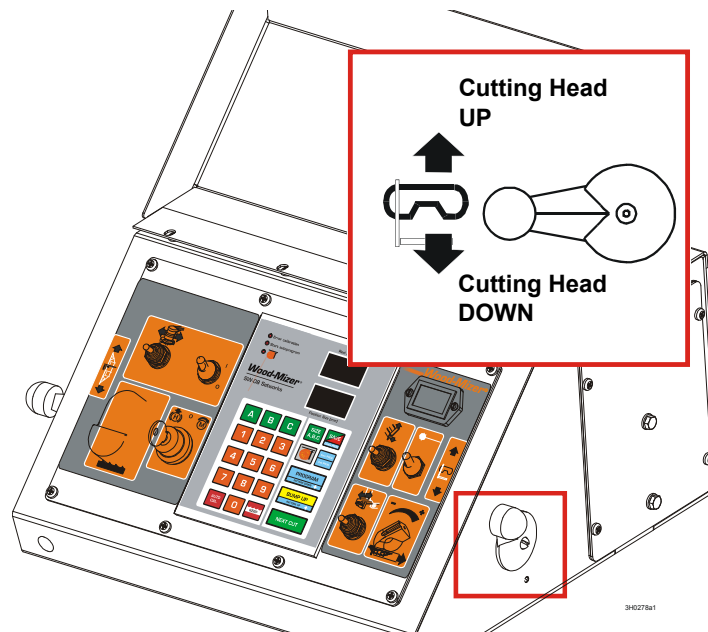

**FIG. 1-9**

The up/down switch is designed to return to the neutral or "off" position when released. If the switch remains engaged, manually move the switch to the neutral or "off" position. Repair the up/down drum switch ( ).



**CAUTION!** Always make sure the up/down switch moves to the neutral or "off" position when released to ensure that the saw head stops moving. Failure to do so may result in machine damage.

**CAUTION!** DO NOT try to force the carriage above the 35" (88 cm) mark or below the 1" (2.54 cm) mark. Damage to the up/down system may result.

### 1.13 Blade Guide Arm Operation

1. Look down the length of the log to see its maximum width. The outer blade guide should be adjusted to clear the widest section of the log by less than 1" (25.4 mm).
2. Use the blade guide toggle switch on the control panel to adjust the outer blade guide as necessary. Push the switch to the left to move the arm in. Push the switch to the right to move the arm out.

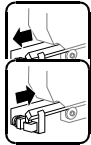

See Figure 1-10.

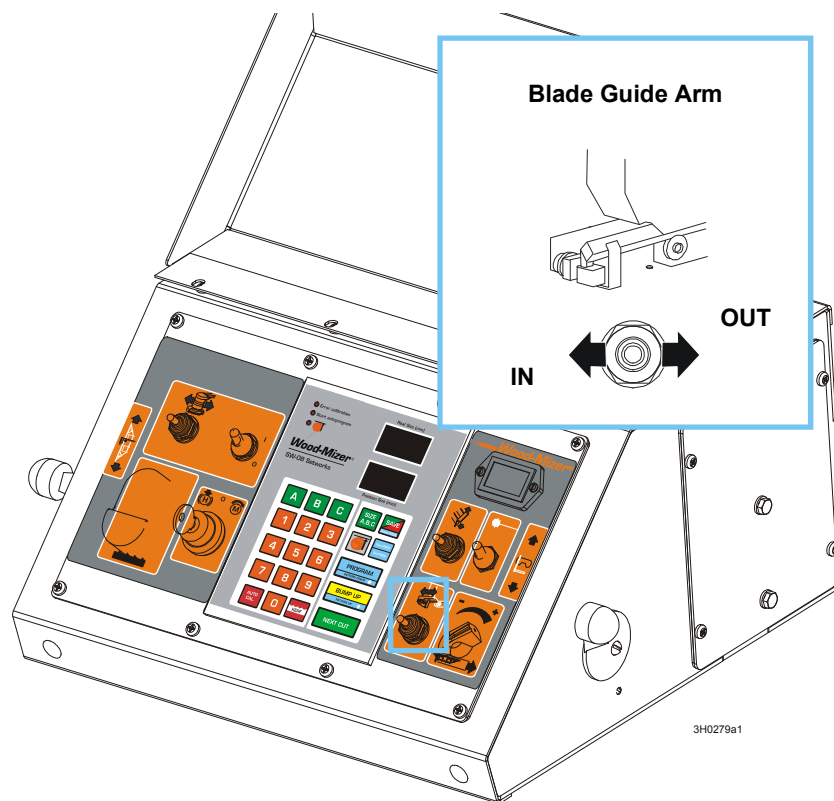
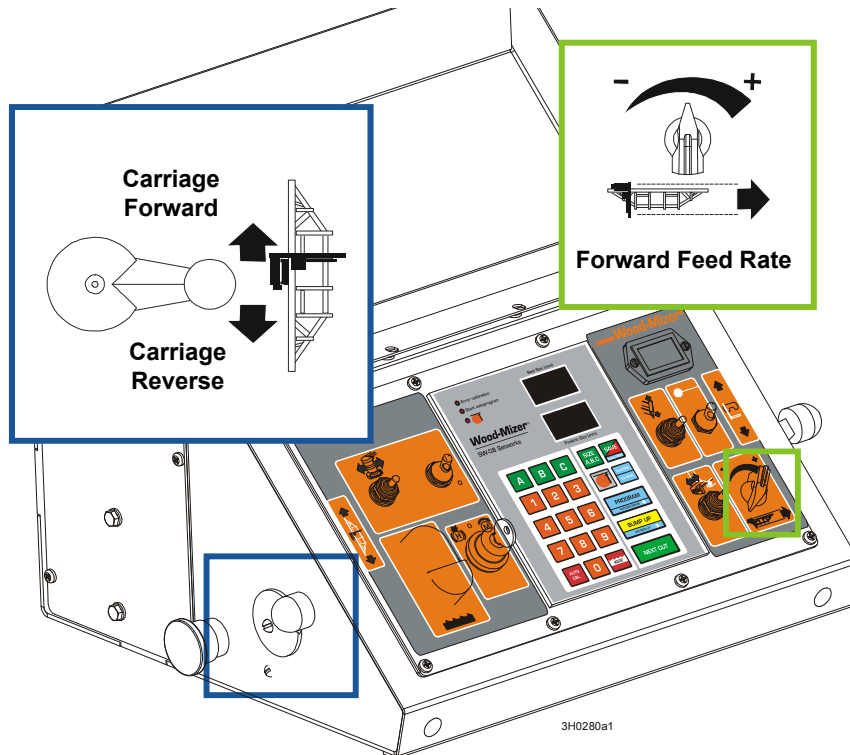

FIG. 1-10

3. Use the blade guide toggle switch to readjust the outer blade guide as you are cutting in order to keep the guide within 1" (2.5 cm) of the log. Be sure to adjust the arm back out before returning the carriage.

## 1.14 Power Feed Operation

See **Figure 1-11**. The power feed system moves the carriage forward and backward by using two switches on the control panel.



**FIG. 1-11**

### Carriage Feed Rate



The carriage feed rate switch controls the speed at which the carriage travels forward. Turn the switch clockwise to increase speed. Turn it counterclockwise to reduce speed.

### Carriage Forward and Reverse

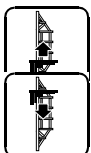

The carriage forward/reverse switch controls the direction in which the carriage travels. Turn the forward/reverse switch upward to move the carriage forward. Turn the switch down to move the carriage backward.

The middle position (as shown) is the neutral position. The power feed switch is designed to return to the neutral or "off" position when released from operating in the reverse position. If the switch remains engaged, manually move the switch to the neutral or "off" position. Repair the drum switch ([See Section 4.2](#)).

# 1 Setup & Operation

## Power Feed Operation

---



**WARNING!** Be sure the power feed switch is in the neutral position before turning the key switch to the (#2) or (#1) position. This prevents accidental carriage movement, which may cause serious injury or death.

### Using The Power Feed

**HINT:** To get a straight cut in the first part of the board, feed the blade into the log at a slow speed. This stops the blade from flexing and dipping up or down. Turn the carriage feed rate switch to a slow speed until the whole width of the blade has entered the cut. Then use the carriage feed rate switch to increase the feed rate as desired. Maximum feed rate varies with width and hardness of the wood. Over-feeding results in engine and blade wear, and also produces a wavy cut.



Stop the carriage at the end of the cut by turning the carriage feed rate switch counterclockwise until the carriage stops moving.

2. Push the STOP button to stop the blade. Remove the board from the top of the log.



**CAUTION!** Be sure to stop the blade when returning the carriage. This will not only prevent the blade from being pulled off and ruined by a wood sliver, but also will increase the life of the blade. [See Section 1.18](#) for optional procedure for Super series mills.

3. Return the carriage to the front of the mill by turning the carriage forward/reverse switch down. **Always disengage the blade before returning the carriage for the next cut.** [See Section 1.18](#) for optional procedure for Super series mills.



**IMPORTANT!** When using a sawmill it is very important not to switch between saw head forward/backward movement until the saw head stops. Failure to do so may result in serious sawmill damage.

4. Make sure that the blade does not catch on the end of the log. Raise the carriage slightly to make sure the blade clears the log when returned. **HINT:** Try to stop the blade while the heel of the blade is still on the log. Then bring the carriage back without adjusting the blade up. This lets you keep the blade at the current height setting so you can make the next blade height adjustment more quickly.



**DANGER!** Stay clear of the area between the trailer axle and saw carriage. Failure to do so will result in serious injury.

## 1.15 Cutting The Log

The following steps guide you through normal operation of the Wood-Mizer sawmill.

1. Once the log is placed where you want it and clamped firmly, turn the key switch to the accessory (#1) position.



2. Use the blade height scale to determine where to make your first cut ([See Section 1.19](#)). The blade height scale will help you to do this. Set the blade to the desired height with the up/down switch. Make sure that the blade will clear all side supports and the clamp. Adjust the outer blade guide to clear the widest section of the log by moving the blade guide toggle switch.



**NOTE:** An optional laser sight is available to help determine where the blade will travel through the log. See the laser sight manual for detailed operating instructions.

3. Make sure all covers and guards are in place. Push the START button to start the blade spinning.
4. Start the water lube if necessary to prevent sap buildup on the blade. [See Section 1.20](#).



5. If you want to use the board return function, push the toggle switch on the control panel down. [See Section 1.9](#).



Feed the blade into the log slowly ([See Section 1.14](#)). Once the blade completely enters the log, increase the feed rate as desired. Always try to cut at the fastest speed you can while keeping an accurate cut. Cutting too slowly will waste blade life and lower production!



As you get to the end of the log, slow down the feed rate. When the teeth exit the end of the log, turn the feed rate all the way down. Push the STOP button to stop the motor. Remove the slab that you have just cut from the log.



8. Use the carriage forward/reverse switch to return the carriage to the front of the mill. Always disengage the blade before returning the carriage for the next cut.

9. Repeat until the first side of the log is cut as desired. Set aside the usable flitches (boards with bark on one or both sides). You can edge them on the mill later.

# 1 Setup & Operation

## Cutting The Log

---



10. Lower the toe boards, if they were used. Use the hydraulic levers to release the clamp and engage the log turner. Turn the log 90 or 180 degrees. Make sure the flat on the log is placed flat against side supports if turned 90 degrees. Make sure it is placed on bed rails if turned 180 degrees. If the log was turned 90 degrees and you are using toe boards to compensate for taper in the log, raise the front or rear toe board again on the second side of the log until the heart is parallel with the bed.

11. Repeat the steps used to cut the first side of the log until the log is square. Cut boards from the remaining cant by adjusting the blade height for the thickness of boards that you want.

**Example:** Remember that the blade cuts a 1/16 - 1/8" (1.6-3.2 mm) wide kerf. If you want 1" (25.4 mm) thick boards, lower the carriage 1 1/16 - 1 1/8" (27-28.6 mm) for each board.

### 1.16 Wireless Control Panel (option)

In LT40M Super sawmills saw head remote control (with wireless control panel) can be used. Saw head remote control allows you to full control of the saw head, i.e. engage and disengage the blade, power and up/down feed, blade guide arm control, debarker control, adjust the feed rate.

See Figure 1-14. Wireless control panel functions.

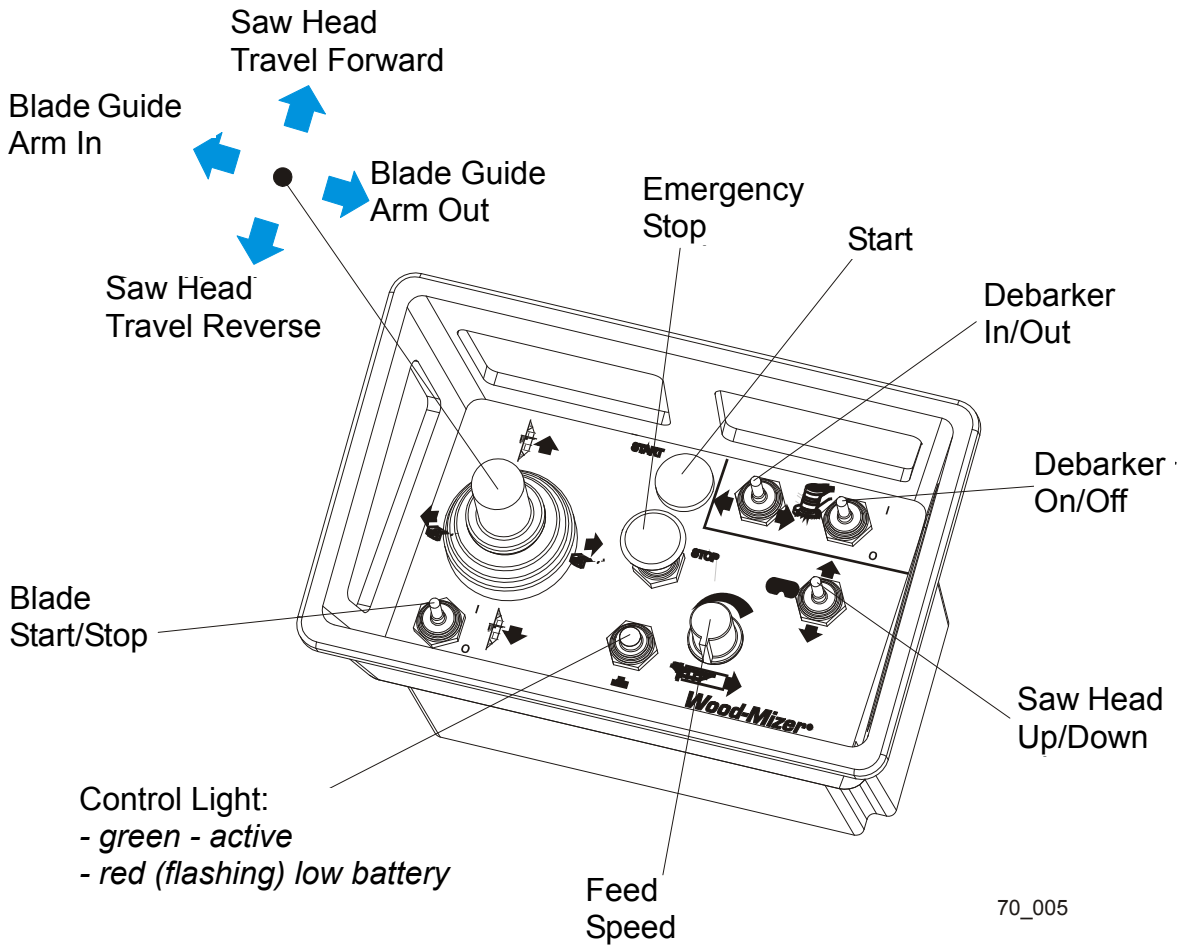

### 1.17 Edging

The following steps guide you through edging boards on the Wood-Mizer sawmill.

1. Raise the side supports to 1/2 the height of the flitches, or the boards that need to be edged.
2. Stack the flitches on edge against the side supports.
3. Clamp the flitches against the side supports halfway up the flitch height. (Wider flitches should be placed to the clamp side. When they are edged, flip them over to edge the second side without disturbing the other flitches or without having to pull them from the middle of the stack).
4. Adjust the blade height to edge a few of the widest boards.
5. Loosen the clamp and turn the edged boards over to edge the other side.
6. Repeat steps 2-4.
7. Loosen the clamp and remove the boards that have good clean edges on both sides. Clamp the remaining flitches and repeat steps 2-5.



## 1.18 Optional Cutting Procedure for Super Series Mills

In order to achieve maximum production rates with Super Series mills; it may be desirable to leave the blade engaged when returning the carriage. (Normal operation procedures recommend disengaging the blade before returning the carriage for maximum blade life and fuel economy.)



**DANGER!** If leaving the blade engaged for maximum production rates, make sure the off-bearer stays out of the path of the blade. Failure to do so will result in serious injury or death.



**CAUTION!** If you choose to leave the blade engaged; raise the blade to clear the log before returning the carriage. Failure to do so may cause damage to the blade and/or sawmill.

## 1.19 Blade Height Scale

See Figure 1-12. The blade height scale is attached to the carriage head frame. It includes:

- a blade height indicator
- an inch scale
- a quarter scale

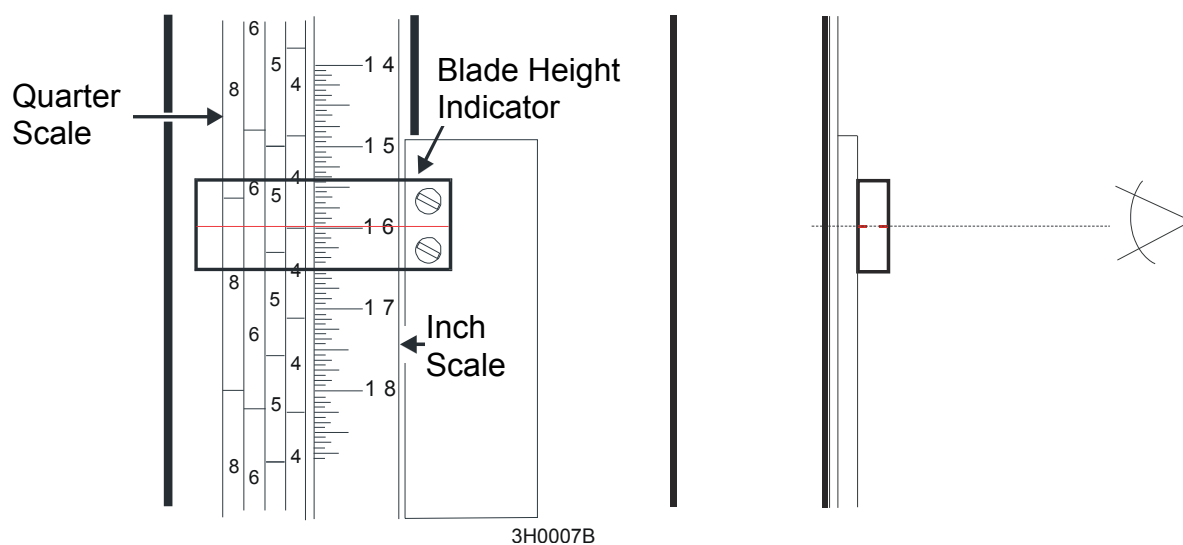

**FIG. 1-12**

The scales are attached to the frame and move up and down with the carriage head. The blade height indicator, used to read the inch and quarter scales, remains stationary.

### Blade Height Indicator

The blade height indicator has two horizontal, red lines on both sides. Readings should be taken with eyes level with the indicator, when the two red lines are in line. This will allow to avoid the parallax error (different scale readings depending on the angle of vision).

### The Inch Scale

The horizontal red line on the blade height indicator shows how many inches the bottom of the blade is above the bed of the mill. If you know the height of your blade at each cut, you can determine the thickness of lumber you are sawing.

**Example:** You want to cut 1" (25 mm) random width boards from a log. Position the blade for the first cut. Move the carriage to an even measurement on the inch scale. Make a trim cut. Return the carriage for the second cut and lower it 1 1/8" (29 mm) below the original measurement. (The extra 1/8" (3 mm) allows for saw kerf and shrinkage of the lumber.)

The yellow area on the scale identifies where the blade could encounter a side support or log clamp. Check that these items are below the blade level before sawing.

# 1 Setup & Operation

## Blade Height Scale

### The Quarter Scale

**See Table 1-15.** Two quarter scales are provided with four sets of marks. Each set represents a specific lumber thickness. Saw kerf and shrinkage allowance are included, but actual board thickness will vary slightly depending on blade thickness and tooth set.

To choose which scale to use, determine what finished thickness you want to end up with. The Grade Hardwood Quarter Scale provides thicker finished boards usually required by commercial buyers. The Standard Quarter Scale allows for kerf and shrinkage of finished boards suitable for most custom applications. Always check with your customer before you saw to determine what actual finished thickness is required.

Standard Quarter Scale		Grade Hardwood Quarter Scale	
Scale	Actual Board Thickness	Scale	Actual Board Thickness
4/4	1" (25 mm)	4/4	1 1/8" (29 mm)
5/4	1 1/4" (32 mm)	5/4	1 3/8" (35 mm)
6/4	1 1/2" (38 mm)	6/4	1 5/8" (41 mm)
8/4	2" (51 mm)	8/4	2 1/8" (54 mm)

TABLE 1-15

To use the quarter scale, look at the blade height indicator. Line up the horizontal red line on the indicator with the nearest mark on the scale you want to use. Make a trim cut. When you return the carriage for a second cut, lower the carriage to the next mark on the scale. This mark shows where the blade should be positioned to cut a certain thickness of lumber, without having to measure on the inch scale.

**Example:** You want to cut 1" (25 mm) (4/4) random width boards from a log. Position the blade for the first cut. Adjust the quarter scale so a 4/4 mark is aligned with the red line on the indicator. Make a trim cut. Return the carriage for the second cut. Now, instead of having to measure down 1 1/8" (29 mm) on the inch scale, you can simply lower the blade so the indicator is aligned with the next 4/4 mark on the quarter scale. Turn the log 90 degrees and repeat.

## 1.20 Water Lube Operation

See **Figure 1-13**. The Water Lube System keeps the blade clean. Water flows from a 5-gallon (18.9 liter) bottle through a hose to the blade guide where the blade enters the log. A valve in the bottle cap controls the amount of water flow.

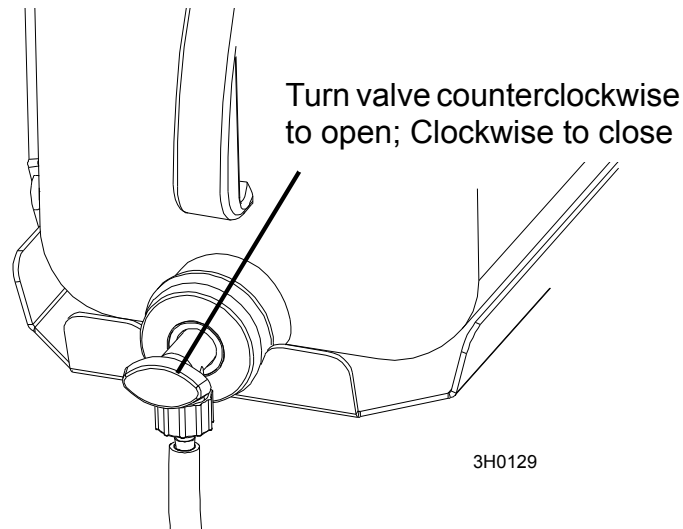

**FIG. 1-13**

Super models include a solenoid valve that will automatically start the water flow when the power feed is activated in the forward direction. The solenoid will stop the water flow when the feed switch is returned to the neutral position.

Not all types of wood require the use of the Water Lube System. When it is needed, use just enough water to keep the blade clean. This saves water, and lowers the risk of staining the boards with water. Usual flow will be 1-2 gallons (3.8-7.6 liters) per hour. A squirt of liquid dishwashing detergent in the water bottle will help clean the blade when cutting wood with a high sap content.



**WARNING!** Use ONLY water with the water lube accessory. Never use flammable fuels or liquids. If these types of liquids are necessary to clean the blade, remove it and clean with a rag. Failure to do so may result in serious injury or death.

Before removing the blade, start the motor. Let the blade spin with water running on it for about 15 seconds. This will clean the blade of sap buildup. Wipe the blade dry with a rag before storing or sharpening.

If you are sawing in freezing temperatures, remove the water lube bottle from the sawmill when done sawing and store it in a warm place. Blow any remaining water from the water lube hose.

To remove water from the water valve on Super models, turn the key switch to accessory (#1), turn the feed rate knob down to '0' and place the feed switch in the forward position. Blow any remaining water from the water lube hose and valve. Return the forward/reverse switch to neutral and turn the

# 1 Setup & Operation

## Preparing The Sawmill For Transportation

key switch to off (#0).

### 1.21 Preparing The Sawmill For Transportation

The Wood-Mizer trailer package for the LT40 sawmills makes transporting your sawmill easy and convenient. To get your sawmill ready for towing, follow these instructions.

1. Move the saw carriage to the front end of the sawmill. Raise the rear outriggers.
2. Move the clamp to the main bed rail as close as possible.

 **CAUTION!** Move the hydraulic clamp and turner to provide maximum ground clearance before towing. Failure to do so may result in damage to the sawmill.

3. Move the carriage forward to the travel position over the bed rail. Position the hole in the saw head over the travel rest pin.
4. Secure the rest pin using locking pin.

See Figure 1-16.

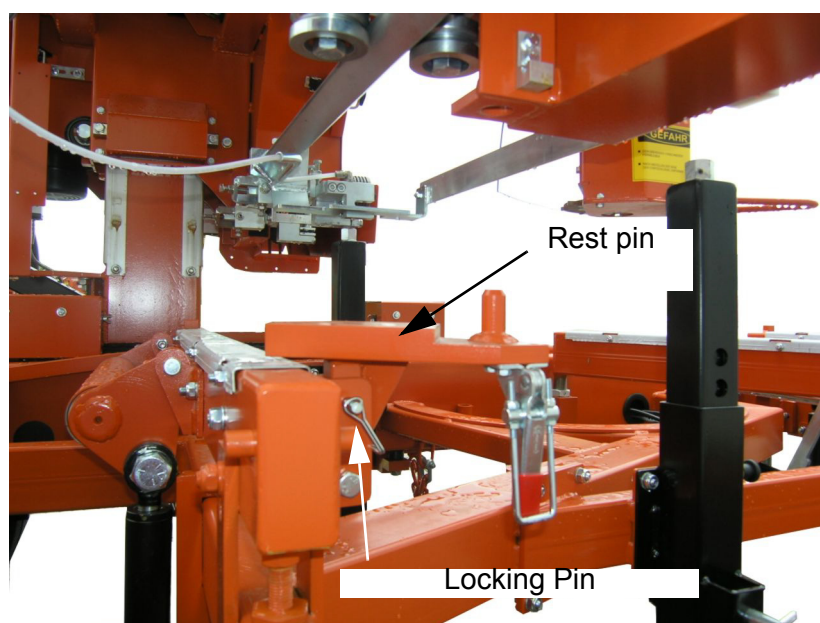

FIG. 1-13

5. Lower the saw head until it contacts the stop blocks on the mast rails. Secure the saw head with locking clamp.

See Figure 1-17.

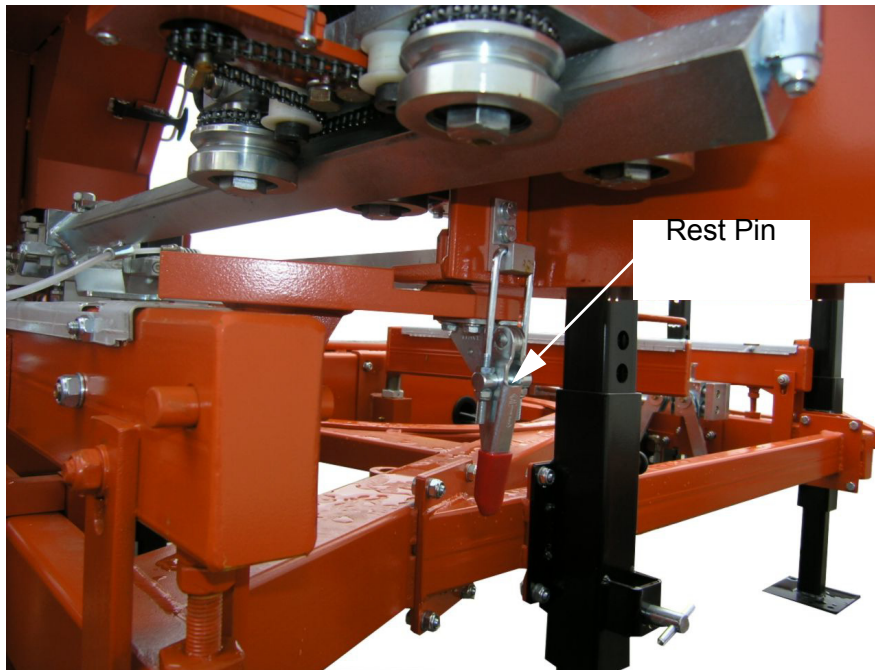

FIG. 1-13



**CAUTION!** It is important that the lower stop bolts are properly adjusted to secure the carriage on the track rail. Failure to properly adjust the stop bolts can cause saw head damage, especially during mill transportation.

6. If necessary, adjust the two stops located at the bottom of the mast so the saw head contacts them after it is lowered  $\frac{3}{4}$ " (19mm) past where it contacts the rest pin.

See Figure 1-18.

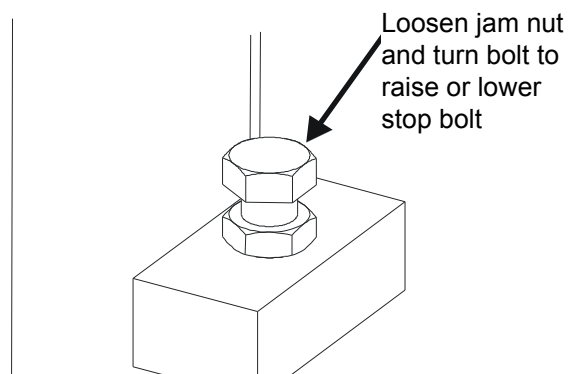

FIG. 1-13

7. Use the hydraulic controls to raise the log turner and loader as high as they will go. Manually lift the loader and hook the loader chain to the elbow of the turner. Use the hydraulic turner lever to lower

# 1

## Setup & Operation

### *Preparing The Sawmill For Transportation*

---

the turner until the chain is tight. Push the loader lever down to bring the loader arm channels up to the loader.

8. Mount the control box blockade on the saw head track rails. Lock hydraulic control box by inserting the locking pin into the hole of the control box blockade.



## SECTION 2 MAINTENANCE

This section lists the maintenance procedures that need to be performed.



**WARNING!** Disconnect and lock out power supply before servicing, cleaning and doing maintenance to the saw! Failure to do so may result in serious injury.

The Short Interval Maintenance Schedule lists procedures that need to be performed every 4, 8 or 24 hours. The Maintenance Log lists procedures that need to be performed every 50, 100, 200, or 1000 hours. Keep track of machine maintenance by filling in the machine hours and the date you perform each procedure.



**This symbol** identifies the interval (hours of operation) which each maintenance procedure should be performed.

This section lists only part of the maintenance procedures that need to be performed in LT70 sawmills. Be sure to refer to option and engine manuals for other maintenance procedures.

### 2.1 Wear Life

**See Table 2-1.** This chart lists estimated life expectancy of common replacement parts if proper maintenance and operation procedures are followed. Due to the many variables which exist during sawmill operation, actual part life may vary significantly. This information is provided so that you may plan ahead in ordering replacement parts.

Part Description	Estimated Life
B72.5 <sup>1</sup> Blade Wheel Belts	500 hours
Up/Down Motor	2000 hours
Drum Switch, Up/Down Motor	1000 hours
Blade Guide Rollers	1000 hours
Power Feed Drum Switch	1200 hours
Drive Belt	1250 hours
Power Feed Motor	1500 hours
Power Feed Drive Belt	2000 hours
Up/Down Belt	2000 hours

**TABLE - 0-0**

<sup>1</sup> To insure proper blade tracking, use Goodyear, Dayco Super II, or Browning belts only.

## 2.2 Blade Guides

1. Check the rollers for performance and wear every blade change. Replace any rollers which have worn smooth or have become cone shaped. Make sure the rollers are clean and spinning freely. If not, rebuild them.

### Steel Guide Blocks

2. Inspect the blocks at every blade change for damage or wear.

As the blocks wear, the front inside corner will wear more than the body of the block. When the corner wears far enough, sawing performance will be affected even if the body of the block is adjusted properly to the blade. At this point, the block should be replaced. If you have access to the appropriate equipment, you can grind or mill the blocks to a new flat surface and reuse them. It is recommended you develop a routine schedule for replacing the blade guide blocks based on your sawing conditions and experience.

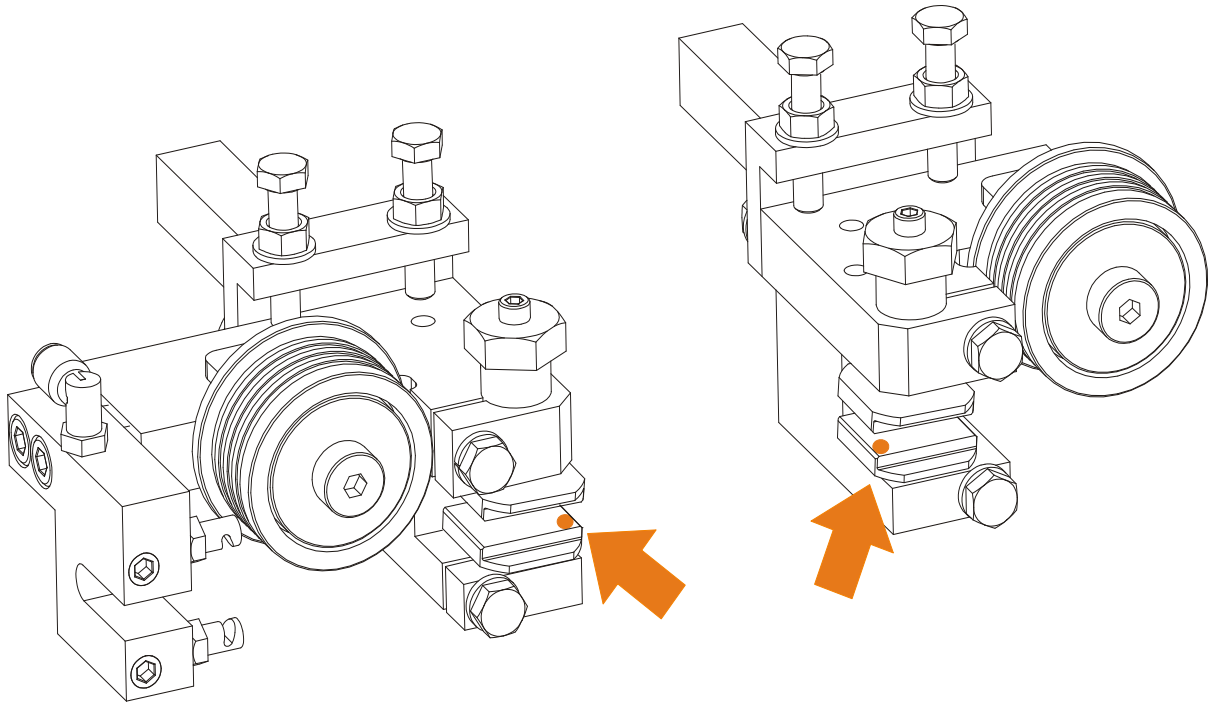

FIG. 2-0

3. Check the inserts are properly spaced from the bottom of the blade every 25 hours of operation. As the rollers wear, the gap between the blade and inserts will become larger. Use the provided shim or a feeler gauge to check the inserts are adjusted 0,3 - 0,5 mm from the blade.

25

**See Figure 2-1.** To adjust the disks up, loosen the bottom guide disk mounting bolt and clamp bolt. Use the provided adjustment tool. to raise bottom disk Retighten the bottom disk mounting bolt and clamp bolt. [See Section Blade Disk Adjustment](#)

**IMPORTANT!** The disks should be parallel to the blade. Check the space between the disks and the blade at each side of the disks to insure it is parallel. Use the appropriate adjustment bolt to tilt the disks mounting plate so the insert is parallel to the blade.

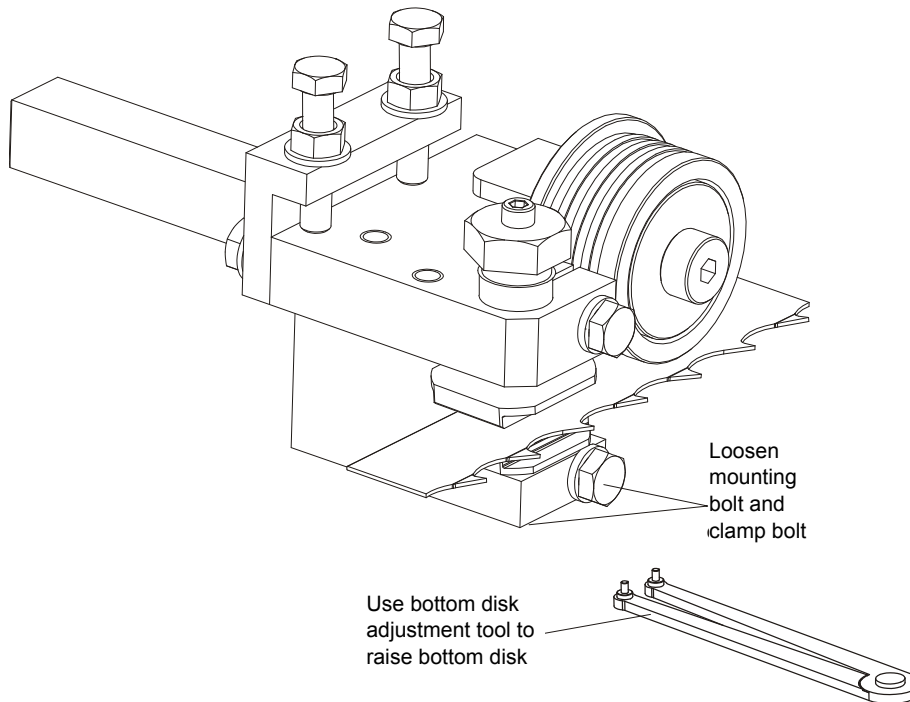

FIG. 2-1

**A/R** Inspect the blade guide assemblies for proper alignment every time you change the blade. [See Section 2.2 Blade Guides](#) for blade guide adjustment instructions..

**WARNING!** Blade guide alignment is essential for optimal cutting performance, blade life and safety. Failure to check and maintain proper blade guide alignment will result in stress cracks forming in the blade. These cracks will lead to premature blade breakage. If the blade breaks during operation and the blade has multiple stress cracks, the blade could shatter into several pieces and escape from the protective guards of the sawmill. Small blade pieces projected into the area around the sawmill creates a safety hazard for the operator and any bystanders surrounding the mill.

**WARNING!** DO NOT use blades with stress cracks. Blades with stress cracks can shatter causing bodily injury and/or machine damage.

Preventing sap buildup on the blade is critical when using the high-performance blade guide system. If the wood you are sawing leaves sap buildup using plain water in the blade lube system, use Wood-Mizer lube additive (Part No. 033439).

**Throat Screw**

Make sure the blade screw in the top center of the C-frame is 1/16" (1.5 mm) away from the blade. If not, loosen the nut and adjust the screw as necessary. Check the screw every blade change. Failing to maintain this adjustment will lead to early blade breakage.

See Figure 2-2.

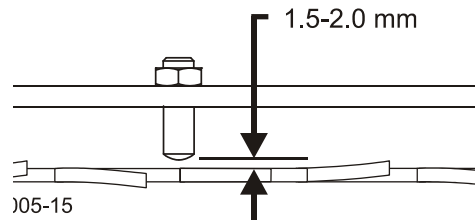

FIG. 2-2

## 2.3 Sawdust Removal

1. Remove the excess sawdust from the blade wheel housings and sawdust chute every blade change.
- 8 2. Remove all sawdust and debris from around the velocity fuse valves every 8 hours of operation. The valves are located at the bottom of the log loader cylinders. Remove sawdust buildup as necessary from the battery box lid and top rail cover. Remove sawdust buildup as necessary from the rail cover.

Failure to remove sawdust buildup from the battery box lid and/or track rail cover could result in damage to these parts when the saw head is lowered to its lowest position.

## 2.4 Carriage Track, Wiper & Scrapers

Properly maintaining the sawmill carriage track is critical in preventing corrosion that can cause pitting and scaling on the rail surfaces. Pitted and scaled surfaces can, in turn, cause rough cuts or jerky power feed movement.

See Figure 2-3.

- 8 1. Clean track rails to remove any sawdust and sap buildup every eight hours of operation.

Use a light-grade sandpaper or emery cloth to sand off any rust or other adhering particles from the rails.



**CAUTION!** Keep track rails free of rust! Formation of rust on the track rail in the areas where the cam bearings roll can cause rapid deterioration of the track rail's surface.

Lubricate the rails by wiping them with Dexron III ATF transmission fluid, 10W30 motor oil, or 3-in-1 turbine oil. Oil lubrication will help protect the rails from corrosive elements such as acid rain and/or moisture from nearby bodies of saltwater (if applicable). This lubrication is essential to maintain the integrity of the track rails and track rollers and to achieve long service life.

- 25 2. Remove sawdust from the track roller housings and lubricate the felt track wiper every twenty-five hours of operation.

Remove the track roller housing covers and brush any sawdust buildup from the housings.

3. Check the track scrapers as needed. Make sure the scrapers fit firmly against the rail. If a track scraper needs to be adjusted, loosen the thumb screw, push the scraper downward until it fits firmly against the rail, and retighten the thumb screw.

- 25 Clean and lubricate the upper track wiper every twenty-five hours of operation. Unbolt the wiper, remove it from the sawmill, and remove any sawdust buildup. Soak the felt wiper with Dexron III transmission fluid, 10W30 motor oil or 3-in-1 turbine oil.



**CAUTION!** Reinstall the track wiper so that it lightly touches the track rail. If the wiper presses too firmly against the rail, it can cause the power feed to bind.

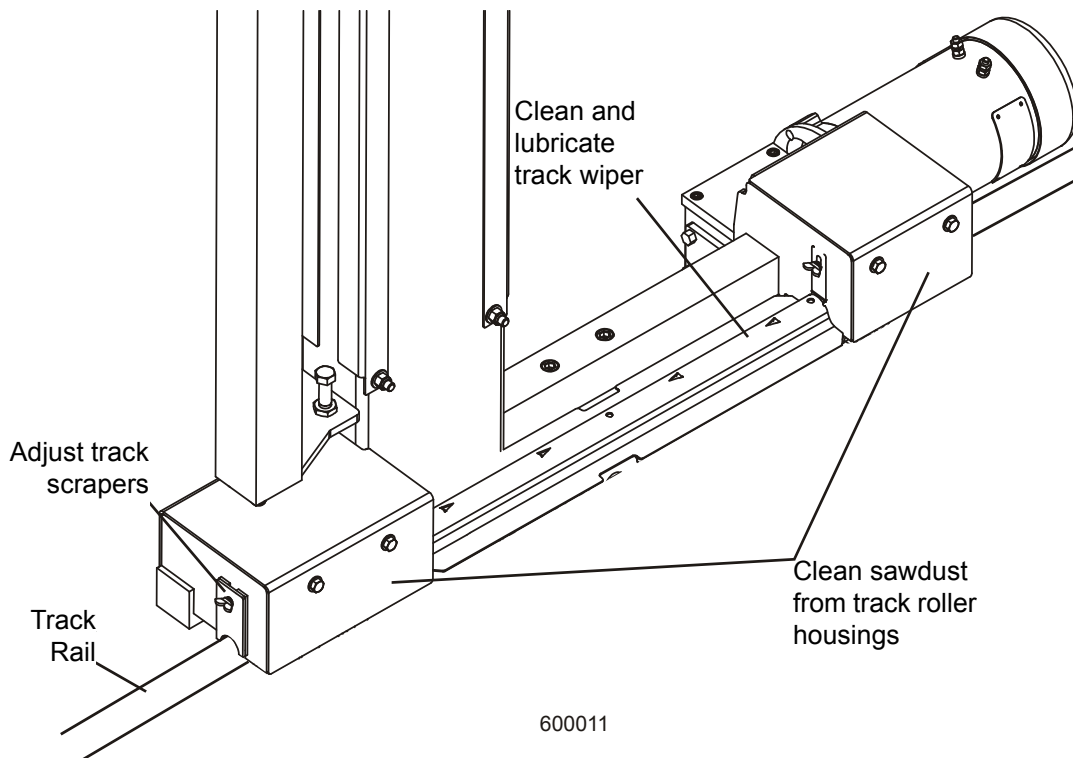

**FIG. 2-3**

## 2.5 Vertical Mast Rails

- 50 Clean and lubricate the vertical mast rails every 50 hours of operation. Clean with solvent and remove any rust with a light-grade sand paper or emery cloth. Lubricate the mast with motor oil or automatic transmission fluid (ATF).



**CAUTION!** Never use grease on the mast rails as it will collect sawdust.

## 2.6 Drum Switches

- 50 Lubricate the up/down and power feed drum switch contacts inside the control panel every fifty hours of operation. Use only contact grease supplied by Wood-Mizer. Remove the control panel cover. Use a cotton swab to apply grease to the switch contact ends.



**WARNING!** Drum switch grease contains Petroleum Hydrocarbon Lubricant. Eye and skin irritant. If introduced into eyes, flush with water for at least 15 minutes. If film or irritation persists, seek medical attention. Wash skin with soap and water. If ingested, do not induce vomiting - contact a physician. KEEP OUT OF THE REACH OF CHILDREN.

## 2.7 Miscellaneous Maintenance

- 50 1. Oil all chains with Dexron III ATF every fifty hours of operation.



**CAUTION!** Do not use chain lube. It causes sawdust buildup in chain links.

- 50 2. Apply a thin film of a NLGI No. 2 grade lithium grease to the blade guide arm every fifty hours of operation to help prevent it from rusting.

- AR 3. Adjust the blade guide arm drive chain as necessary. To adjust the chain, loosen the blade guide arm motor mounting plate bolts and slide the motor to take slack out of the chain.

- 50 4. Grease the clamp mechanism, loading arms, and side supports with a NLGI No. 2 grade lithium grease every fifty hours of operation.

- 50 5. Lubricate the board return pivot every fifty hours of operation with a NLGI No. 2 grade lithium grease. Apply grease to the grease fitting on the board return pivot tube.

6. Check the mill alignment every setup. See Section 5, Alignment.

7. Make sure all safety warning decals are readable. Remove sawdust and dirt. Replace any damaged or unreadable decals immediately. Order decals from your Customer Service Representative.

## 2.8 Drive Belt Adjustment



**DANGER!** Never adjust the drive belts while the engine is running. Failure to do so may result in serious injury.



Periodically check the drive belt for wear. Replace any damaged or worn belts as needed.

**See Figure 2-4.** Adjust proper drive belt tension using the bolt located between the drive side wheel covers. To tighten drive belt turn the bolt clockwise. To loosen drive belt turn the bolt counter clockwise.

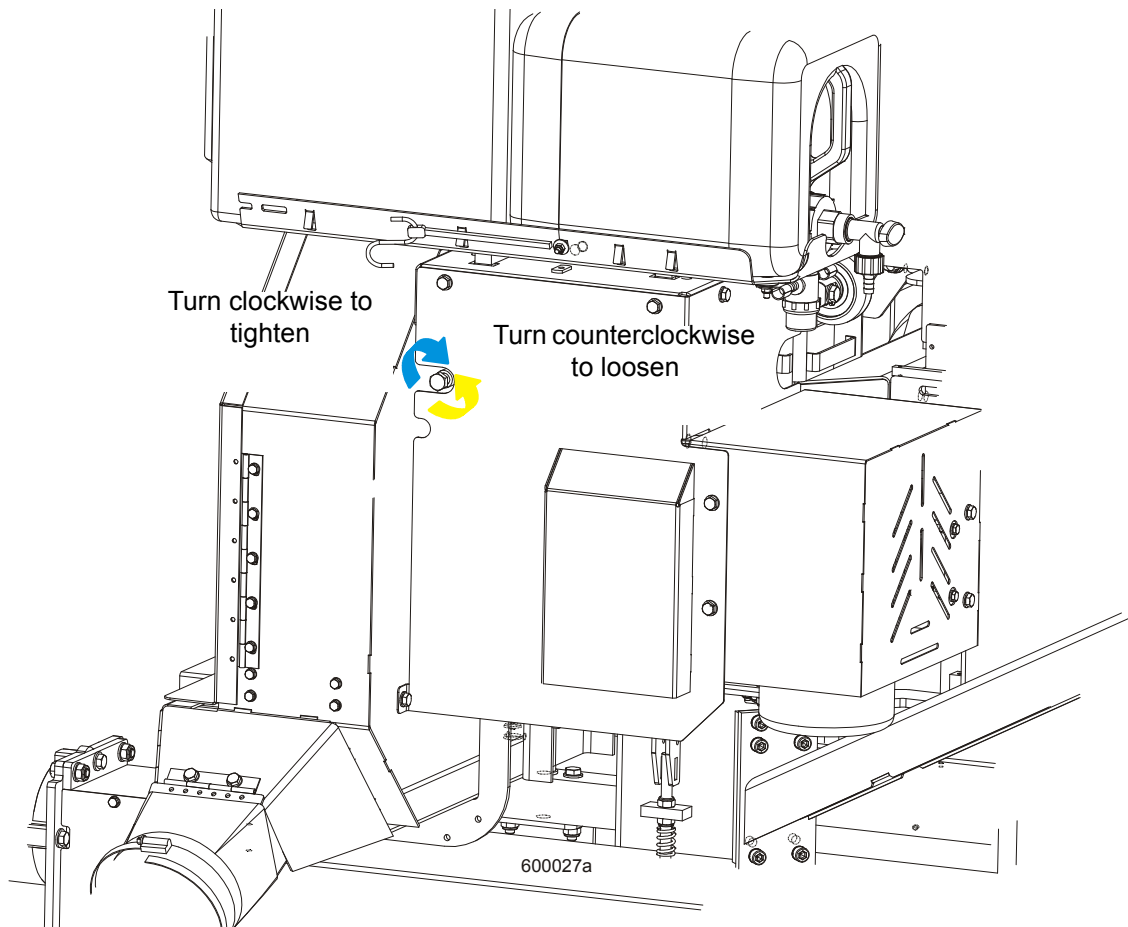

**FIG. 2-4**



## 2.9 Up/Down System

750

Adjust the up/down chain tension as needed. Measure chain tension with the head all the way to the top of the vertical mast. Find the chain adjusting bolt at the bottom of the mast. Use the adjustment nut to adjust the bolt until the center of the chain can be deflected 3/4" (1.9cm) with a 5 lb. (2.3 KG) deflection force..



**CAUTION!** Do not over-tension the chain. Over-tensioning the chain may lead to early failure of the gear reducer.

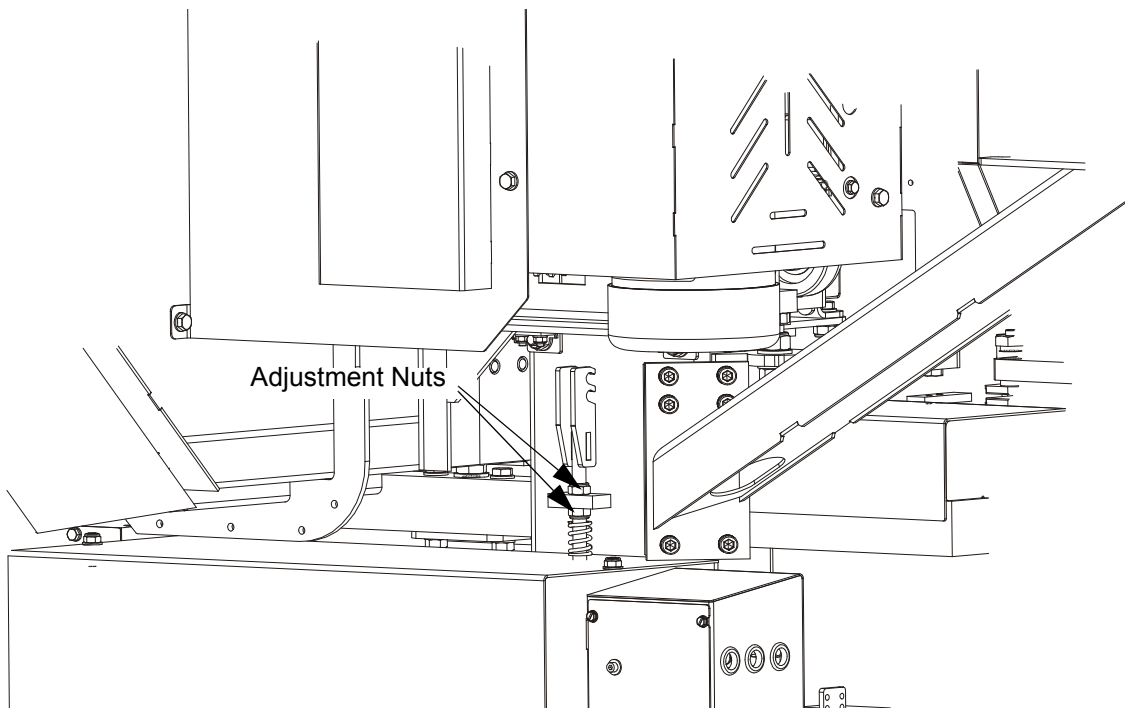

**FIG. 2-4**

1. Adjust the motor belt tension as needed. To do this, loosen the motor mounting bolts and turn adjustment bolts clockwise or counterclockwise evenly, until the belt is properly tensioned. Tighten the motor mounting bolts.

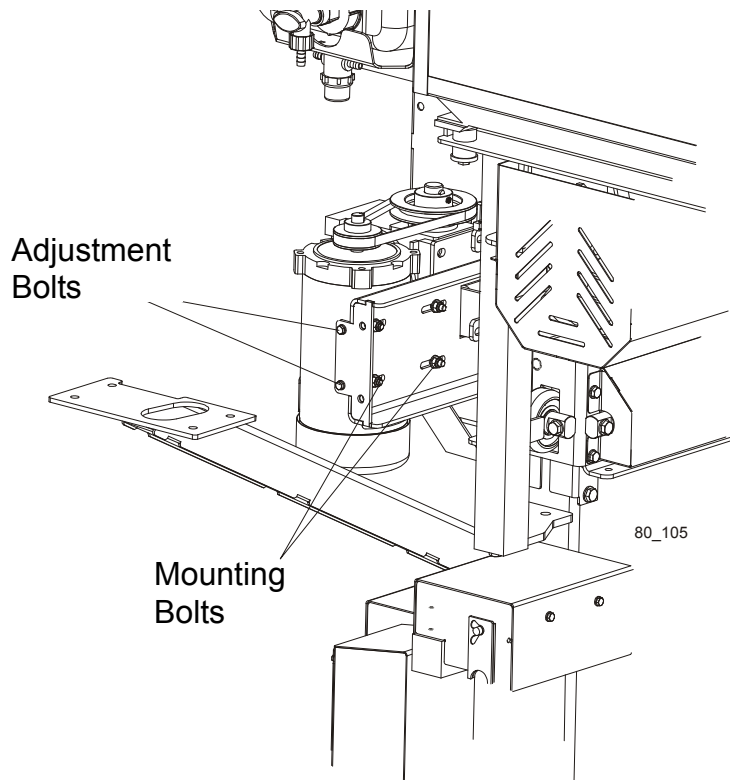

**FIG. 2-4**

AR

Periodically check the belt for wear. Replace any damaged or worn belts as needed.

2. When oil leaks from the gear reducer please contact Customer Service.

## 2.10 Power Feed

1. Adjust the power feed chain as needed. Measure the power feed chain tension with the saw head all the way toward the front of the mill. Use the two lock nuts to tighten or loosen the power feed chain. Adjust the chain until it measures 7 to 8 inches (17.8 to 20.3 cm) from the top of the top rail at its lowest point.



**CAUTION!** Do not overtighten the feed chain. Damage to the power feed motor may result.

See Figure 2-5.

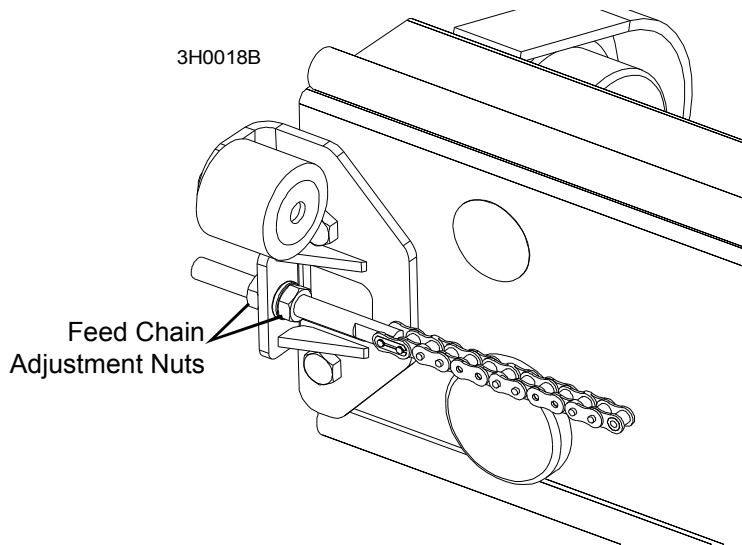

FIG. 2-5

## 2.11 Hydraulic System

1. Check the hydraulic fluid level every fifty hours of operation. Add fluid as necessary. The level in the hydraulic pump should be 3/4" (19mm) from the top with all cylinders collapsed.

If humidity is a problem or the mill is used outside in humid weather, drain and replace two quarts (.95 liters) of fluid every six months. This will drain any accumulated water and help prevent pump failure due to water ingestion. It also will prevent excessive fluid wear and allow the fluid to maintain its hot end performance. If humidity is not a problem, drain and replace one gallon (3.8 liters) of fluid every year to prevent fluid wear.

1. If you are operating in temperatures -20° to 100° F (-29° to 38° C), use an all-weather hydraulic fluid such as Exxon Unavis J26. For alternate fluids and/or other temperature ranges, refer to the chart below. Operating above the recommended temperature range of a fluid could result in excessive pump wear. Operating below the recommended temperature range could result in reduced hydraulic cylinder speed. To change fluid types, replace one gallon of the current fluid with one gallon of the alternate fluid.

**TEMPERATURE**

F -30° -20° -10° 0° 10° 20° 30° 40° 50° 60° 70° 80° 90° 100° 110° 120°

C -35° -29° -23° -18° -12° -7° -1° 5° 10° 16° 21° 27° 32° 38° 44° 49°

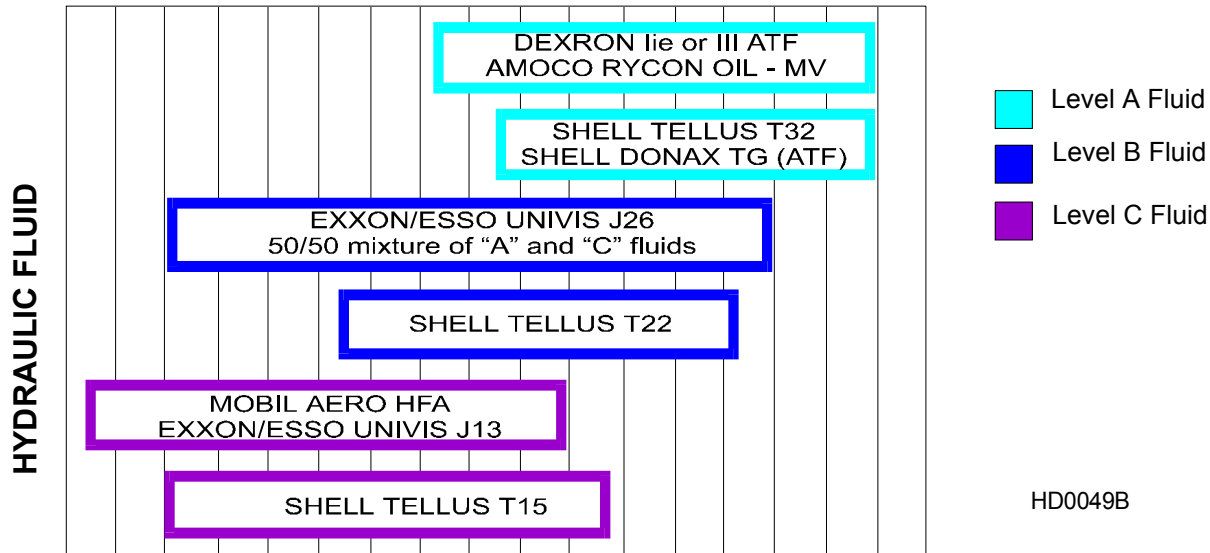

**FIG. 2-6**

500

Replace the hydraulic system cartridge filter every 500 hours of operation. Inspect the hydraulic pump motor brushes every 750 hours of operation. Remove brush dust and replace the brushes if they worn to a length of 1/4" or shorter. Do not operate the hydraulic system if the pump motor brushes are worn shorter than 1/4". Damage to the pump motor may result

2. Periodically check all hydraulic lines and fitting as needed. Replace as necessary.

## 2.12 Safety Devices Inspection

### *LT70 AC – Safety Devices Inspection*

Safety devices on the LT70AC machine which must be checked before every shift:

- E-STOP button and its circuit inspection
- Inspection of the control circuits with the E-STOP button pressed
- Blade cover safety switch #1 and its circuit inspection
- Blade cover safety switch #2 and its circuit inspection
- Motor brake and its circuit inspection

#### **1. E-STOP button and its circuit inspection**

- Turn on the blade motor;
- Press the E-STOP button located on the left side of the control box. The blade motor should be stopped. Pressing the START button should not start the motor until the E-STOP button is released.

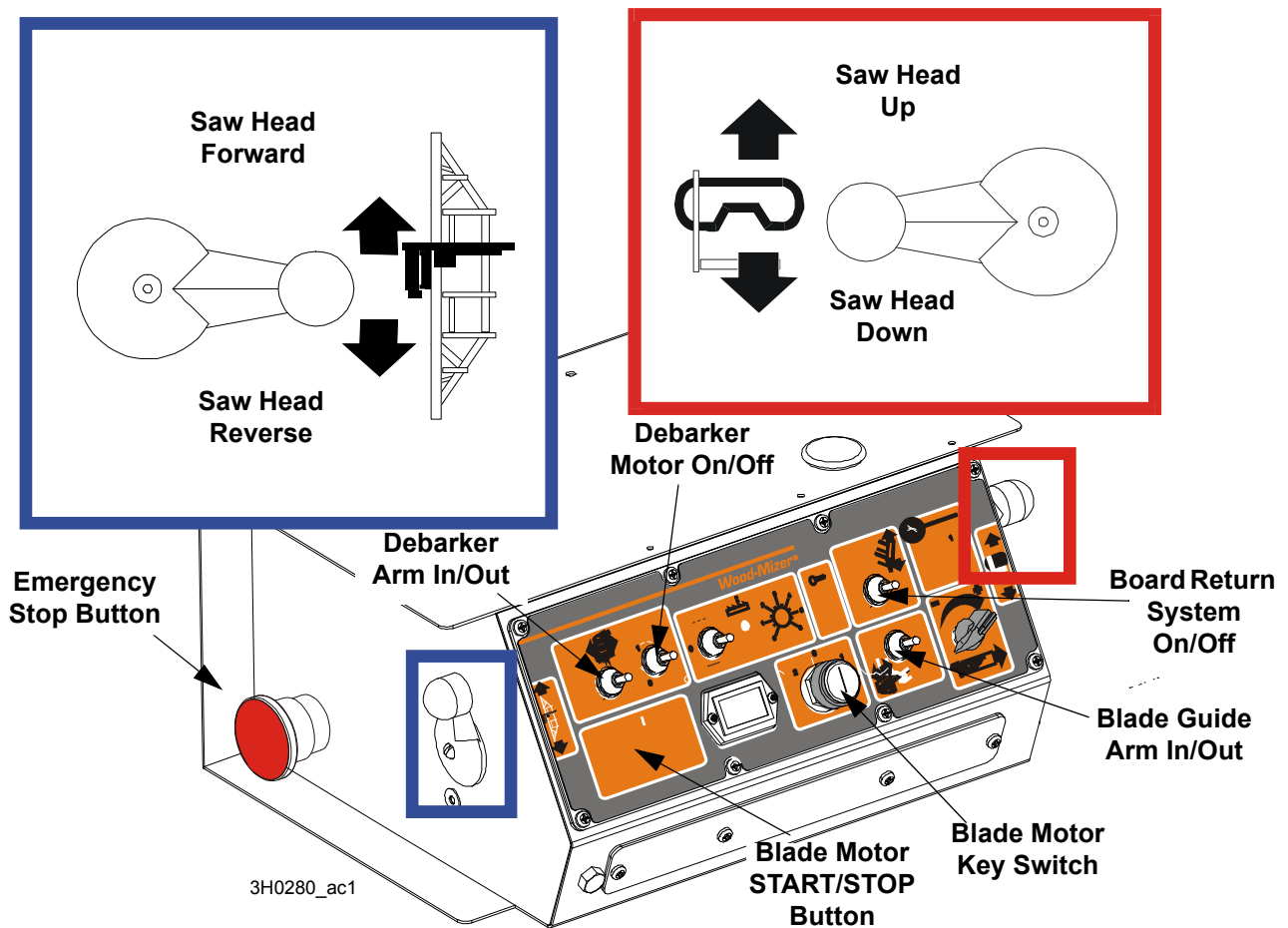

**2. Inspection of the control circuits with the E-STOP button pressed**

- Turn on the blade motor;
- Press the E-STOP button located on the left side of the control box. The blade motor should be stopped.
- With E-STOP button pressed, try to move the saw head up and down using the switch and the Setworks buttons and forward/backward using the power feed switch. Both systems should not start.
- With E-STOP button pressed, try to start the debarker blade motor and move the debarker arm in and out. The debarker should not work.
- With E-STOP button pressed, try to move the blade guide arm in and out. The blade guide arm should not work.
- With E-STOP button pressed, try to start the board return system. The board return system should not work.

**3. Blade cover safety switch #1 and its circuit inspection.**

- Turn on the blade motor;
- Open the blade housing cover #1;

- The blade motor should be stopped;
- Try to start the motor. The blade motor should remain stopped;
- Close the blade housing cover #1;
- The blade motor should remain stopped until it is restarted with the START button.

**4. Blade cover safety switch #2 and its circuit inspection.**

- Turn on the blade motor;
- Open the blade housing cover #2;
- The blade motor should be stopped;
- Try to start the motor. The blade motor should remain stopped;
- Close the blade housing cover #2;
- The blade motor should remain stopped until it is restarted with the START button.

**5. Motor brake and its circuit inspection**

- Turn on the blade motor. Stop the motor using the STOP button. Measure the braking time.
- Turn on the blade motor. Stop the motor by switching the key to the “0” position. Measure the braking time.
- Turn on the blade motor. Stop the motor by switching the key to the “2” position. Measure the braking time.
- The braking time should always be shorter than 10 seconds. If the braking time is longer, it is necessary to adjust or replace the motor disk brake. See your motor option manual.

## SECTION 3 TROUBLESHOOTING

### 3.1 Sawing Problems

PROBLEM	CAUSE	SOLUTION
<b>Blades Dull Quickly</b>	Dirty logs	Clean or debark logs, especially on entry side of the cut
	When grinding teeth, heating too much and causing teeth to soften	Grind just enough metal to restore sharpness to the teeth. Use water/coolant while sharpening blade
	Poor sharpening techniques	Make sure the tip is being sharpened completely (See Sharpener Manual)
<b>Blades Break Prematurely</b>	Rubber belts on blade wheels worn to a point that blade contacts metal pulley - look for shiny spots on edge of wheels	Change blade wheel belts (B-57)
	Poor sharpening techniques	See Sharpener Manual
	Tension too tight	Tension blade to recommended specifications
<b>Blade Does Not Track Right on Drive Wheel</b>	Cant adjustment is incorrect	Readjust
	Flat/worn belts	Replace B-57 belts
<b>Blade Guides Do Not Spin While Cutting</b>	Frozen bearings	Replace bearings
	Stiff bearings	Grease bearings
<b>Drive Belts Wear Prematurely or Jump</b>	Engine/motor and drive pulleys out of alignment	Align drive pulleys <a href="#">See Section 3.5 Engine/Motor Drive Pulleys Alignment.</a>



PROBLEM	CAUSE	SOLUTION
<b>Boards Thick Or Thin On Ends Or Middle Of Board.</b>	Stress in log which causes log to not lay flat on the bed.	After log has been squared, take equal cuts off opposing sides. Take a board off the top. Turn the log 180 degrees.. Take a board off. Repeat, keeping the heart in the middle of the cant, and making it your last cut.
	Set in teeth.	Resharpener and reset blade.
	Bed rails misaligned.	Realign sawmill.
<b>Height Adjustment Jumps or Stutters When Moving Up or Down.</b>	Mast needs lubrication.	Lubricate mast track surface
	Up/down chain improperly adjusted.	Adjust up/down chain.
	Drive belt(s) loose.	Adjust drive belt(s)
<b>Lumber Is Not Square</b>	Vertical side supports not square to bed	Adjust side supports.
	Blade not parallel to bed rails	Adjust bed rails parallel to blade.
	Sawdust or bark between cant and bed rails	Remove particles
<b>Sawdust Builds Up On Track</b>	Tooth set problem	Resharpener and reset blade.
	Excessive oiling	Do not oil track
	Track wipers worn	Adjust wipers to firmly contact track
	Track is sticky	Clean track with solvent and apply silicone spray
<b>Wavy Cuts</b>	Excessive feed	Slow feed rate
	Improperly sharpened blade (This will be the problem 99% of the time!)	Resharpener blade (See Sharpener Manual - read entire manual!)
	Blade guides improperly adjusted	Adjust blade guides.
	Sap buildup on blade	Use Water Lube.
	Tooth set problem	Resharpener and reset blade.

## 3.2 Electrical Problems

PROBLEM	CAUSE	SOLUTION
<b>Up/down Excessively Slow.</b>	Up/down rollers stuck.	Adjust rollers.
	Up/down belt loose.	Adjust belt to be as loose as possible without slipping
	Thermal overload tripped	Reset.
<b>Up/down Or Power Feed Motors Do Not Work.</b>	Worn/dirty contacts in drum switch.	Replace switch or remove control panel cover and clean contacts.
	Bad key switch.	Replace key switch.
	Circuit breaker.	Reset breaker in control box ( <a href="#">See Section 4.11</a> ).
	Burned-out motor.	Replace motor
<b>Power Feed Motor Does Not Work.</b>	Sawdust buildup in the power feed pulleys.	Sawdust buildup puts mechanical bind on power feed which causes thermal overload. Remove sawdust from pulleys and operate normally. Reset overload and operate normally.
<b>Up/Down Or Power Feed Switches Remain Engaged When Switch Is Released.</b>	Worn or dirty contacts in drum switch.	Manually move the power feed or up/down switch back to neutral position. Replace drum switch or remove control panel cover and clean and lubricate contacts <b>NOTE: NOTE:</b> Use only contact grease supplied by Wood-Mizer.
	Drum switch spring broken	Manually move the power feed or up/down switch back to neutral or "off" position. Replace drum switch spring.
<b>Up/Down Or Power Feed Motors Overheat And Loose Power.</b>	System overload or bind occurred.	Correct problem. <a href="#">See Section 3.3 Power Feed Problems</a> . Allow motor to cool before restarting.
	Normal operation factors exceeded (eg: up/down control jockeyed excessively).	Allow motor to cool before restarting.

### 3.3 Power Feed Problems

problem	CAUSE	SOLUTION
<b>Power Feed Is Jerky At Low Speeds Or Does Not Move Until Speed Is Above Halfway Mark</b>	Drum switch is dirty	Clean drum switch and lubricate with grease supplied by Wood-Mizer.
	Worn drum switch contacts	Check that contacts are in good condition and positively close circuit.
	Components are loose or wires are broken.	Replace or repair PC board.
<b>Power Feed Is Jerky When Shaft Of Feed Rate Dial Is Moved Back And Forth.</b>	Variable speed switch is bad - perform the variable speed switch test.	Replace variable speed switch.
<b>Power Feed Is Jerky, But Power Feed Motor Runs Properly At All Speeds.</b>	Problem is mechanical.	Refer to the Mechanical Test.
<b>Power Feed Is Sluggish, Trips Circuit Breaker Or Current Limit.</b>	Sawdust buildup in power feed cover.	Remove power feed belt cover and remove sawdust.

## 3

**Troubleshooting***Power Feed Problems*

<b>problem</b>	<b>CAUSE</b>	<b>solution</b>
<b>Power Feed Motor Overheats.</b>	Middle track oiler is dragging.	Clean middle track oiler and lubricate. Allow motor to cool before restarting.
	Ground is not level.	Level mill with carpenter's level. Allow motor to cool before restarting
	Track roller bearing drag is excessive.	Lubricate bearings; Replace tight bearings. Allow motor to cool before restarting
	Lower track rollers are not aligned properly.	Check stop block clearance from lower track rail. Allow motor to cool before restarting
	Chain is dragging.	Make sure chain is centered on cam follower bearing; Clean and lubricate chain; Adjust chain tension. Allow motor to cool before restarting
	Chain is improperly tensioned.	Adjust chain tension. Allow motor to cool before restarting.
	Seat load is excessive.	Check seat bearings for freedom of movement; Loosen clamping screw 1/4 turn. Allow motor to cool before restarting
	Power feed is binding.	Adjust belt tension; Check condition of belt, pulleys, bearings, and sprocket; Check motor for ground fault. Allow motor to cool before restarting
	Saw head load is excessive.	Avoid unnecessary modifications to saw heads that would give them extra weight. Allow motor to cool before restarting.
	Blade is dull or improperly set.	Use proper blade maintenance procedures (See Sharpener or Toothsetter manual). Allow motor to cool before restarting

### 3.4 Hydraulic Problems

PROBLEM	CAUSE	SOLUTION
<b>You Can Actuate Any Hydraulic Handle, But Get No Response From The Pump.</b>	Carriage not positioned properly to provide drive signal to the hydraulic control	Make sure carriage contact bracket is adjusted far enough forward for battery positive contact to touch strip on main tube. Check contact and strip for tarnish or loose wires. Clean as necessary
	Poor ground connection.	Check negative contact and lower rail. Check contact and rail for tarnish or loose wires. Clean as necessary.
	Circuit breaker tripped	Reset breaker.
	Defective pump motor	Replace
<b>You Can Get Response From the Pump By Actuating All But One or Two Handles</b>	Poor cable connection	Check cable connection.
	Defective motor pump contactor	Replace
	Valve assembly switch contacts are not properly adjusted	Locate the valve switch at the bottom of the valve assembly. Use a 3MM allen wrench to loosen the set screw on each of the five switch contacts. Press each contact to the valve block and tighten the contact set screw to secure in place. <b>CAUTION!</b> Do not overtighten!
		<b>NOTE:</b> Do not adjust the valve switch or switch spring; they have been preset at the factory.

## 3

## Troubleshooting

## Hydraulic Problems

PROBLEM	CAUSE	SOLUTION
	Low fluid level	Check fluid level. Add an all-season hydraulic fluid such as Amoco Rycon Oil MV or Mobil Multipurpose ATF (automatic transmission fluid) until level is 4 - 4 1/2" from bottom of reservoir with all cylinders retracted
	Pressure relief valve moved from proper setting	Adjust pressure relief valve.
	Low air temperature causing oil to thicken	Allow fluid to warm up. Synthetic fluids are available that allow for hydraulic operation in cold weather conditions (Exxon/Esso Univis J26).
<b>Pump Motor Runs Continuously When Power Contact Is Made</b>	Solenoid is stuck closed	Tapping the solenoid may solve this problem temporarily. Replace solenoid.
<b>Fluid Leaks From Around Cylinder Piston Ram</b>	Worn seals	Replace seals in cylinder. Check piston ram for abrasive weld that may be causing premature seal failure
<b>Fluid Leak Around Pump Box</b>	Loose seal or fitting	Wipe pump off completely to locate cause of leak. You may have to unbolt the pump to wipe behind it. <b>NOTE:</b> Movement of the sawmill can cause fluid to slosh up into the foam filter in the reservoir cap, and subsequently spray out, giving the appearance that fluid is leaking from the pump

PROBLEM	CAUSE	SOLUTION
<b>Hydraulic Side Supports Go Down Before Or At Same Time As Log Turner</b>	Dirt in sequence valve	Remove sequence valves and clean thoroughly with kerosene. <b>NOTE:</b> Be sure to reassemble the valve and install it in its original position on the cylinder
	Retainer in sequence valve worn	Replace sequence valve
	Low air temperature causing oil to thicken	Allow fluid to warm up. Synthetic fluids are available that allow for hydraulic operation in cold weather conditions (Exxon/Esso Univis J26).
<b>Hydraulic Turner Goes Up Before Or At Same Time As Side Supports</b>	Spring weakening in sequence valve	Locate sequence valve at top of turner cylinder. Turn heavy spring in about 1/4 turn
	Dirt in sequence valve	Remove sequence valves and clean thoroughly with kerosene. <b>NOTE:</b> Be sure to reassemble the valve and install it in its original position on the cylinder
	Retainer in sequence valve worn	Replace sequence valve
	Low air temperature causing oil to thicken	Allow fluid to warm up. Synthetic fluids are available that allow for hydraulic operation in cold weather conditions (Exxon/Esso Univis J26).
	Spring weakening in sequence valve	Locate sequence valve at bottom of turner cylinder. Turn heavy spring in about 1/4 turn

### **3.5 Engine/Motor Drive Pulleys Alignment**

1. Install the drive belt..
2. Use a straight edge to align the engine/motor pulley to the drive pulley. Also check that the engine pulley is linear with the drive pulley. Loosen the engine mounting bolts and rotate the engine if necessary..
3. Check front-to-back movement of the engine does not exceed 1/4". Tighten the motor mount U-bolts if necessary..
4. Engage the clutch handle and adjust the drive belt tension to 7/16" deflection with 10 lb. of force.
5. Recheck the pulley alignment and engine squareness with the clutch handle engaged. Adjust if necessary.
6. Adjust the drive belt support to 1/4" ( $\pm 1/32$ ) from the belt while engaged.

### **3.6 Power Feed Variable Speed Switch Test**

With the feed rate dial switch all the way down, move the shaft of the dial back and forth to see if there is a jerky response. Turn the dial and move the shaft back and forth again. Repeat several times. If the jerkiness occurs at the same location on the dial several times, you need to replace the variable speed switch.

### **3.7 Power Feed Preliminary Test**

This test will determine if the problem is a mechanical or electrical.

1. Remove the drive belt from the power feed drive pulley..
2. Turn the key switch to the ACC position. Put the carriage forward/reverse switch into the forward position and turn the feed rate dial through all speeds. If the power feed motor runs properly at all speeds, the problem is a mechanical one instead of an electrical one.

### **3.8 Power Feed Mechanical Test**

1. Remove the weight from the track rollers. They should turn smoothly and easily with very little play.
2. Make sure the middle track cover is not bent or touching the top rail.
3. Make sure the middle track oiler is free of sawdust buildup.
4. Make sure the power feed chain is not stiff from rust. Also make sure the chain is not too tight.
5. Make sure the power feed chain cam bearing is not touching the main frame tube.
6. Make sure there is no sap or rust on the rails.



7. Make sure the block on the lower track roller assembly is not rubbing the lower rail. Also make sure the track rollers are not too tight.
8. Make sure the power feed belt is properly tightened.

### 3.9 Circuit Breaker Operation

Sawmill controls are equipped with manual reset circuit breakers to protect the electrical circuits.

**See Figure 3-1.** The blade guide and accessory, breakers are located inside the control box. Remove the circuit breaker panel from the control box to access the internal breakers.

**NOTE:** If the breaker is still hot, you may not be able to reset it immediately. Allow the breaker to cool for a few minutes before attempting to reset.

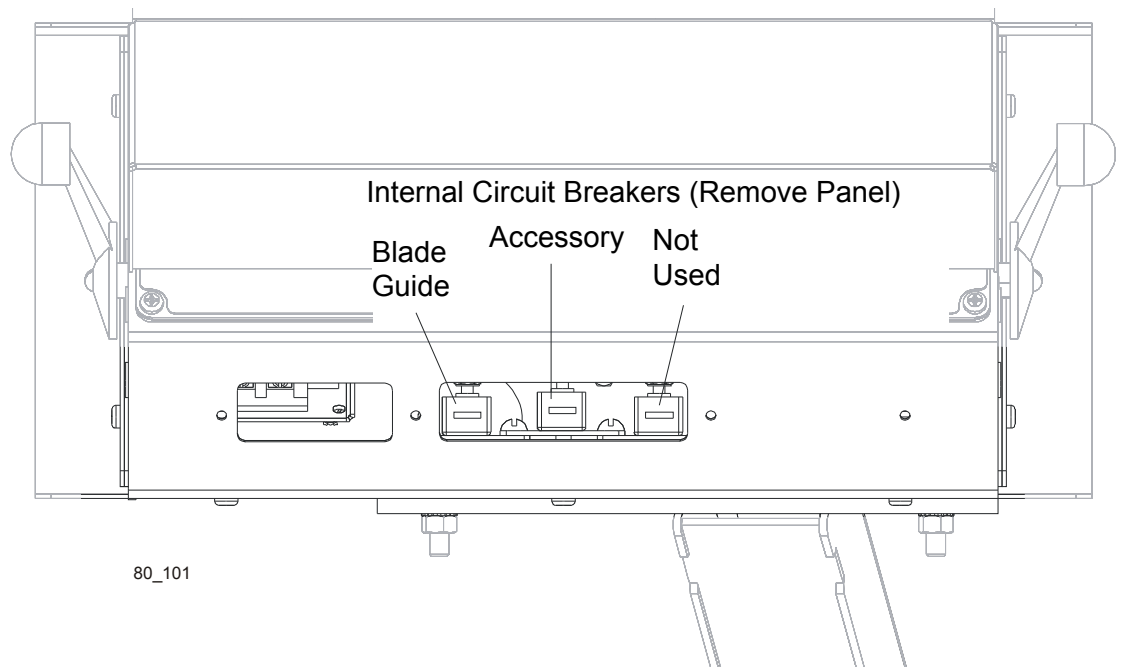

**FIG. 3-1**

## SECTION 4 SAWMILL ALIGNMENT

### 4.1 Pre-Alignment Procedures

The Wood-Mizer sawmill is factory aligned. Two alignment procedures are available to realign the sawmill if necessary. The Routine Alignment instructions should be performed as necessary to solve sawing problems not related to blade performance. The Complete Alignment procedure should be performed approximately every 1500 hours of operation (sooner if you regularly transport the sawmill over rough terrain).

#### **Routine Alignment Procedure:**

1. Install and track the blade ([See Section 4.3](#)).
2. Check the angle of the blade in relation to the bed rails and adjust the lower track rollers if necessary ([See Section 4.18](#)).
3. Check and adjust the vertical alignment of the blade guide arm ([See Section 4.7](#)).
4. Check and adjust the horizontal alignment of the blade guide arm ([See Section 4.8](#)).
5. Check and adjust the vertical angle of the blade guides ([See Section 4.11](#)).
6. Check and adjust the horizontal angle of the blade guides ([See Section 4.13](#)).
7. Check and adjust the spacing between the blade guide flanges and the back of the blade ([See Section 4.12](#)).
8. Check and adjust the horizontal angle of the side supports ([See Section 4.15](#)).
9. Check and adjust the vertical angle of the side supports ([See Section 4.16](#)).
10. Check that the blade height scale accurately displays the actual distance from the bottom of the blade to the bed rails and adjust if necessary ([See Section 4.19](#)).

#### **Complete Alignment Procedure:**

Perform all steps in this section to completely realign the sawmill.

## 4.2 Frame Setup

Stationary sawmills should be setup on firm, level ground before proceeding with alignment. Shim the feet so the weight of the sawmill is evenly supported.

Portable sawmills should also be setup on firm, level ground:

**LT40S AH:** Adjust the two middle outriggers on the main frame tube down just enough to lift weight from the trailer tire.

**LT40M AH:** Adjust the two end outriggers on the main frame tube down just enough to lift weight from the trailer tire.

**All Portable Sawmills:** Adjust the two outer outriggers down just so they touch the ground but do not bear weight.

[See SECTION 2 Setup & Operation](#) for additional setup information.

### 4.3 Blade Installation And Alignment

See **Figure 4-1**. Install a blade and apply the appropriate tension ([See Section 2.6](#)). Blade tension is adjusted with the tension handle shown.

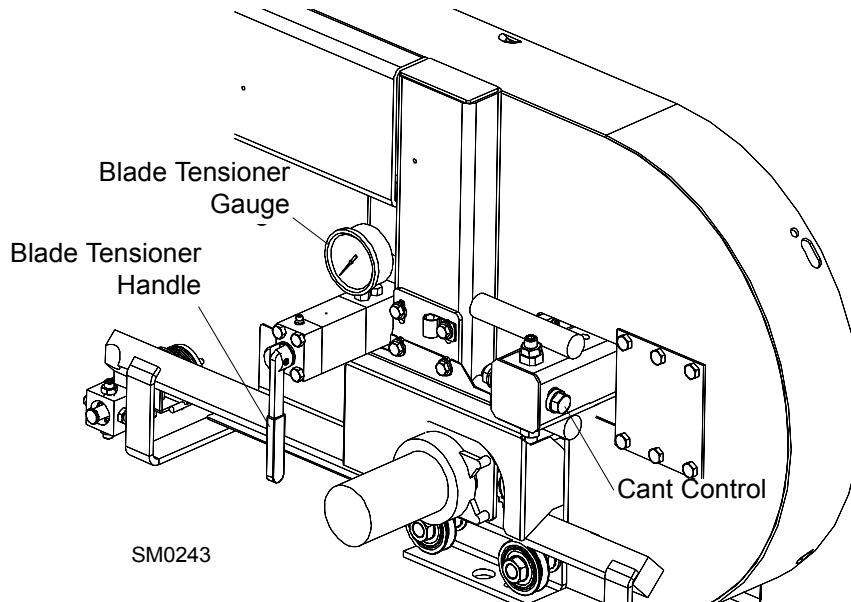
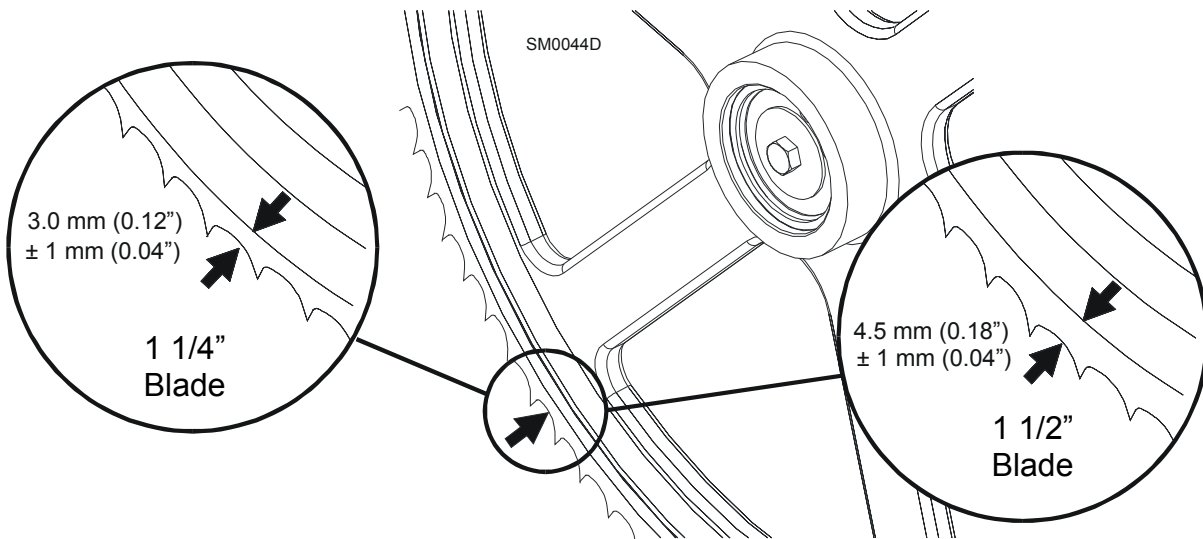

**FIG. 4-1**

1. Raise the middle blade housing cover and make sure all persons are clear of the open side of the saw head.
2. Turn the key switch to position #2.
3. Manually spin idle pulley
4. Remove the key and check the position of the blade on the blade wheels.

Check the vertical alignment of the idle-side blade wheel. The gullet of the blade should ride the same distance from the front edge of the wheel at the top and bottom of the wheel. If it does not, loosen and tighten the appropriate adjustment screws on the wheel shaft.

**See Figure 4-2.** The blade wheels should be adjusted so that the gullet of 1 1/4" blades ride 3.0 mm (0.12") out from the front edge of the wheels ( $\pm 1.0$  mm [0.04"]). The gullet of 1 1/2" blades should ride 4.5 mm (0.18") from the front edge of the wheels ( $\pm 1$  mm [0.04"]). Do not let the teeth ride on the wheels.



**FIG. 4-2**

To adjust where the blade travels on the idle-side blade wheel, use the cant control shown in **Figure 5-1**.

If the blade is too far forward on the wheels, turn the cant control counterclockwise. If it is too far back on the wheels, turn the cant control clockwise.

Some adjustment in blade tension may be needed to compensate for adjustments made with the cant control.

Adjustment with the cant control is usually all that is required to track the blade properly on both blade wheels. The drive-side blade wheel will usually not have to be adjusted. If necessary, the drive-side wheel can be adjusted as follows:

**See Figure 4-3.** For horizontal adjustment, use the horizontal adjustment nuts. If the blade is running too far back on the drive-side blade wheel, locate the long U-bolt on the right which mounts the bearing housing to the mounting plates. Loosen the hex nuts on the U-bolt (on the back side of the back plate). Tighten the adjustment nuts to spread the plates apart and bring the blade forward.

If the blade is running too far to the front, loosen the jam nuts on the long U-bolt and back the adjustment bolts out. Tighten the hex nuts on the long U-bolt (on the back side of the back plate).

Be sure to tighten all nuts against the mounting plates when the adjustment is complete.

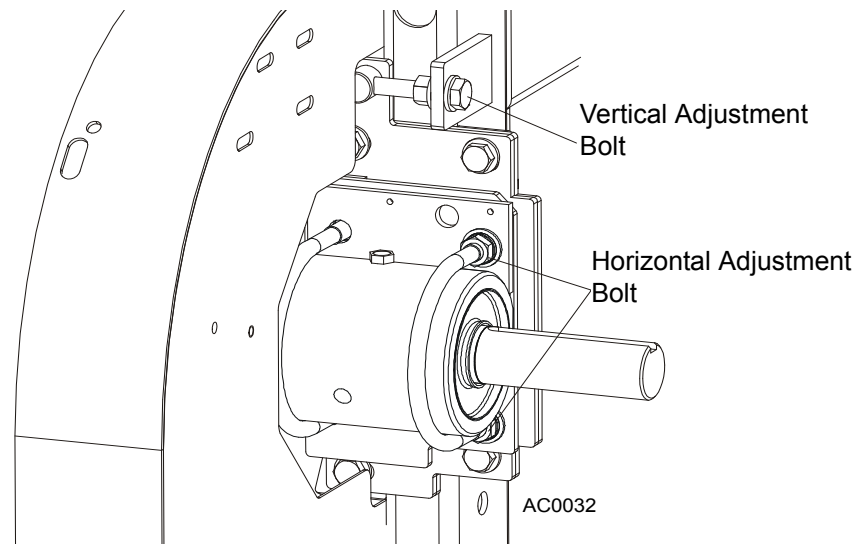

**FIG. 4-3**

The vertical angle of the drive side wheel is factory-set and should not need to be adjusted. If adjustment is needed, use the vertical adjustment bolt. To tilt the wheel upward, loosen the jam nut and turn the vertical adjustment bolt clockwise. To tilt the wheel downward, loosen the jam nut and turn the vertical adjustment bolt counterclockwise. Be sure to tighten the jam nut.

## 4.4 Saw Head Slide Pad Adjustment

There are eight nylon pads positioned between the saw head frame and vertical mast. The spacing of the pads is factory set and rarely needs adjusting. To check the pad spacing, perform the following steps.

**NOTE:** The pads on the engine side of the mast are referred to as the "inner" pads. The pads on the control side of the mast are referred to as the "outer" pads.

**NOTE:** Shims are often used around the clamping bolts, between the C-frame support bracket and the mast v-brace (C). The shims align the v-brace (C) to the mast so that the entire face of each slide pad makes contact with the mast. Be sure to keep these shims in place when performing the following adjustment.

See Figure 4-4.

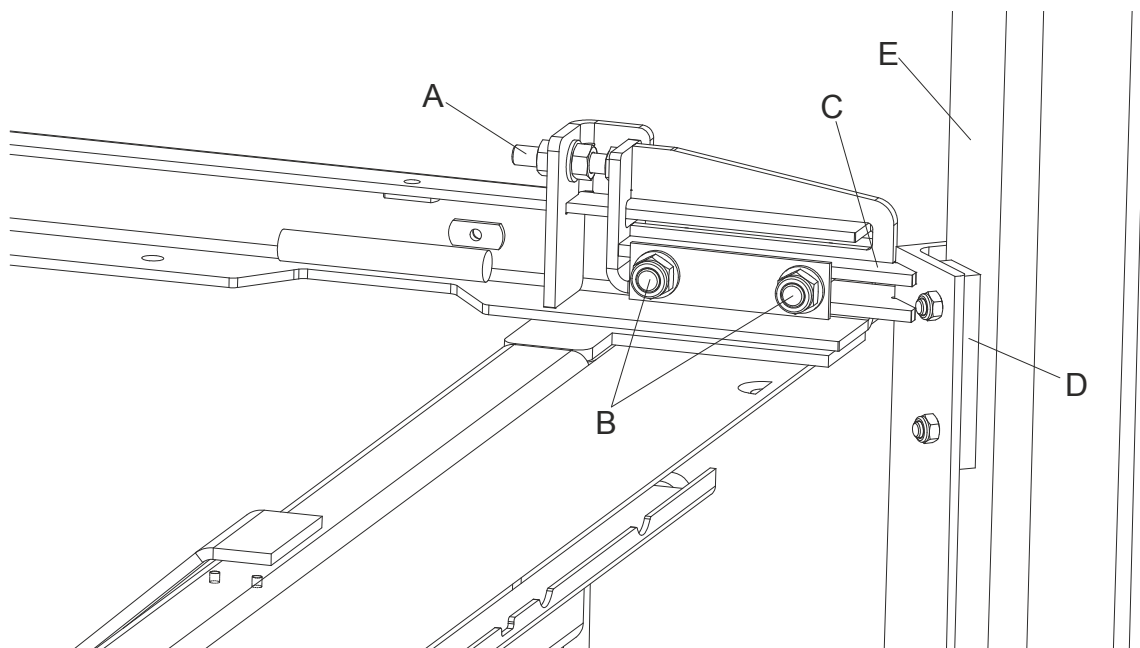

**FIG. 4-4**

1. Raise the saw head to the top of the vertical mast and secure the saw head with a chain at the top, or shim it underneath. Check the top set of four pads (D). The outer two pads should be touching the mast rails (E). There should be a small gap (about 0,2mm wide) between one of the inner pads and the mast rail.



**WARNING!** Always secure the cutting head with a chain or a brace before adjusting the mast pads. The cutting head may fall, causing severe injury or death.

2. To adjust the spacing of the upper set of pads, lower the saw head until you can access the upper slide pad adjustment bolts (D).
3. Loosen the upper locking bolts (B) and turn the adjusting bolt (A) as necessary to provide the pad spacing described in Step 1.
4. Lower the saw head to the bottom of the vertical mast. Check the bottom set of four pads (D).

There should be a small gap between one of the outer pads and the mast rail (E). The gap should be about

0,2mm wide. The inner two pads should be touching the mast rails (E). To adjust the spacing of the lower set of pads, raise the saw head until you can access the lower slide pad adjustment bolts.

5. Loosen the lower locking bolts and turn the adjusting bolt as necessary to provide the pad spacing described in Step 4.



**CAUTION!** Due to variations in the vertical mast, the pad spacing may vary throughout the travel of the saw head. Check the pad spacing at the top and bottom ends of the mast only. Pads adjusted too tight will cause premature up/down motor failure.



## 4.5 Adjusting The Lower Track Rollers

**See Figure 4-5.** Making these adjustments correctly will give you square cuts and accurate dimensions across the width of your boards.

1. Using the feed controls, move the saw carriage so that the blade is positioned over the front pivot end rail.
2. Check the lower roller on the bottom track rail. Make sure that the bottom rollers touch the bottom rail but remain loose enough that you can turn them with your finger. Use the vertical bolts to adjust the bottom track rollers.
3. Check the inside lower rollers. Both inside rollers should touch the rail so that you cannot spin them by hand. If the rollers are not adjusted evenly and you can spin either one, adjust the horizontal nuts until the roller cannot be spun by hand. Check the other roller and adjust if necessary. Adjust both inside rollers until each evenly supports the carriage and you cannot spin either by hand.
4. Move the carriage forward until the blade is positioned over the rear pivot end rail. Repeat steps 2 & 3 until all lower rollers are adjusted properly at the front and rear of the sawmill.

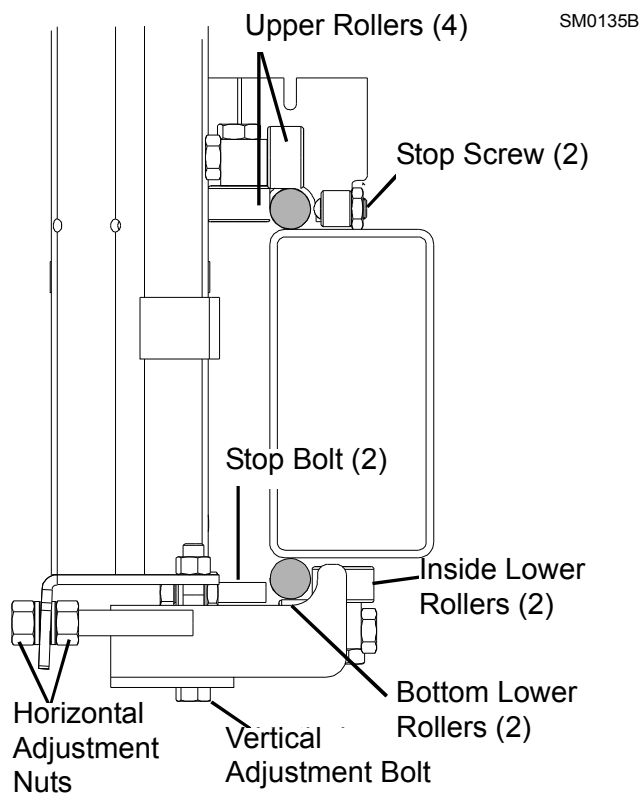

**FIG. 4-5**

5. Remove the blade guides, or adjust them so that they do not touch the blade.
6. Open the adjustable blade guide arm to within 1/2" (15 mm) of full open.
7. Move the carriage back to the front pivot end rail. Raise the cutting head until the bottom of the blade is 17" (400 mm) above the outside of the pivot rail support by actual measurement with a tape or ruler.

See Figure 4-6.

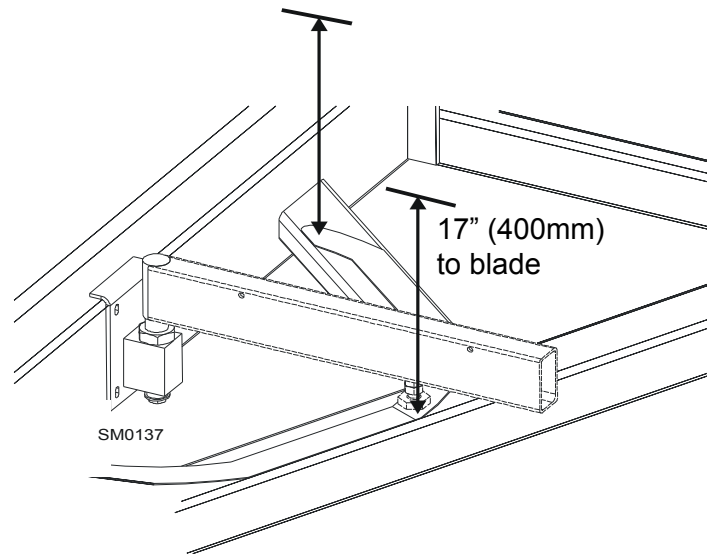

**FIG. 4-6**

8. Move the carriage forward to check the distance to the blade at the inside of the pivot rail support. All measurements should be equal within  $\pm 1.0$  mm.
9. Turn the horizontal adjustment nuts evenly to adjust the inner lower rollers to tilt the saw head until the blade is parallel ( $\pm 1.0$  mm) to the pivot rail support on the outside.

**NOTE:** Adjustments of the lower track rollers change the angle between the cutting head and sawmill bed rails. Only small adjustments of the lower track rollers should ever be needed.

10. After the lower track rollers are adjusted properly, adjust the upper and lower stop screws. Tighten each screw until it just touches the rail. Then, back the screw off 1/2 turn. The gap will be approximately 2.0 mm.



**CAUTION!** It is important that the lower stop bolts are properly adjusted to secure the carriage on the track rail. Failure to properly adjust the stop bolts can cause saw head damage, especially during mill transportation.

## 4.6 Adjusting Bed Rails To The Blade

1. Move the vertical clamp to its lowest position. Before using the clamp tube as a reference to set the blade, make sure it is level.
2. Move the clamp all the way toward the clamp stop. Position the saw head so the blade is over the clamp tube. Measure from the outer end of the clamp tube to the bottom of the blade.
3. Move the saw head back to power the hydraulics and move the clamp all the way out. Position the blade over the clamp tube again and measure from the inner end of the clamp tube to the bottom of the blade.
4. If the clamp tube is level, the measurement to the blade at both ends will be the same within 1/16" (1.5 mm). If adjustment is needed, loosen the four mounting bolts at the outer end of the clamp tube and adjust the clamp tube up or down as necessary. Tighten the mounting bolts.

See Figure 4-7.

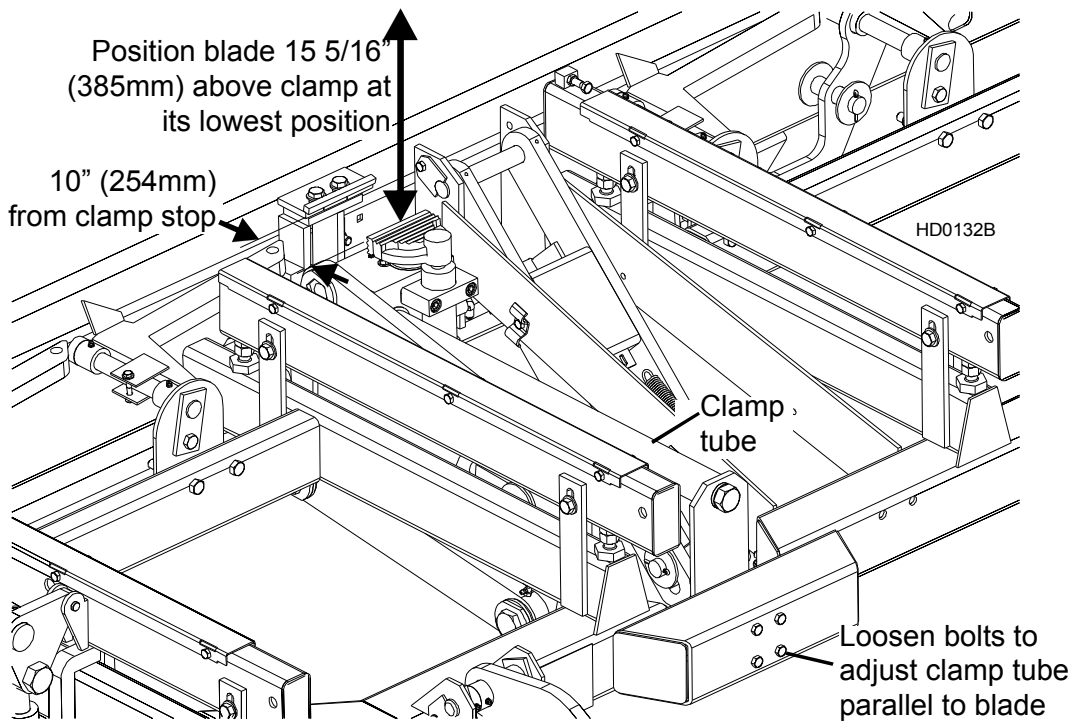

FIG. 4-7

# 4

## Sawmill Alignment

### *Adjusting Bed Rails To The Blade*

5. Move the saw head back to power the hydraulics and move the clamp so it is 10" from the clamp stop. Move the saw head forward until it is positioned over the clamp. Raise the saw head until the blade measures 15 5/16" (385 mm) from the clamp at its lowest position.
1. Adjust the front pivot rail 90° to the main bed tube.
2. Move the saw head to center the blade over the front pivot bed rail.
3. Measure the distance from the top of the pivot rail to the bottom of the blade. Make this measurement at each end of the pivot rail.
4. The two measurements should be 15" (375 mm).
5. Loosen the locking set screws and turn the inner height adjustment nut to adjust the height of the inner end of the pivot rail.

See Figure 4-8.

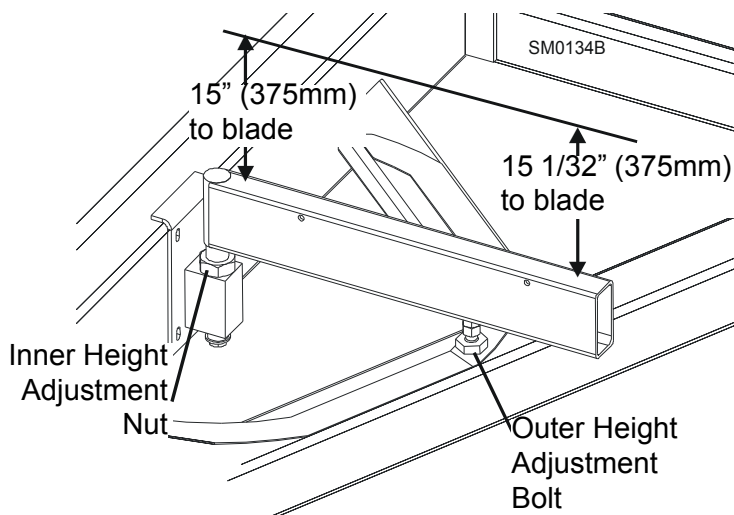

**FIG. 4-8**

6. Loosen the jam nut and turn the outer adjustment bolt to adjust the height of the outer end of the pivot rail.
7. Move the saw head so the blade is positioned over the center of the front main bed rail.
8. Measure the distance between the bottom of the blade and the bed rail at each end of the bed rail. The bed rail should measure 15" (375 mm) (+ 1.0 mm on the outer end) from the blade at each end of the rail.

See Figure 4-9.

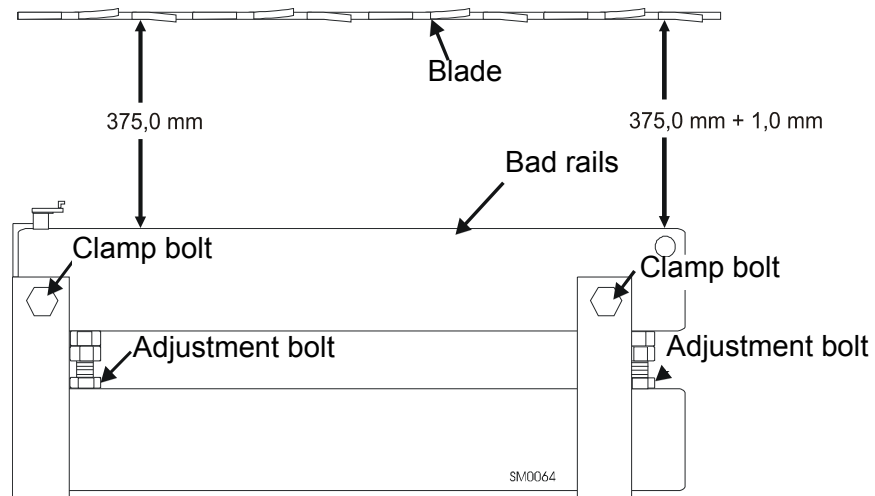

**FIG. 4-9**

9. Loosen the bed rail clamping bolts and turn the adjustment bolts to move the bed rails to the blade if necessary.
10. Retighten the clamping bolts and adjustment bolts.
11. Without adjusting the saw head height, check the three remaining main bed rails and the rear pivot rail. Adjust them so that all measure the same distance from the blade at both ends of the bed rail.

## 4.7 Blade Guide Arm Vertical Adjustment

1. Move the saw head so that the blade guide arm is directly over a bed rail.
2. Adjust the blade guide arm out to within 1/2" (15 mm) of full open.
3. Measure from the top of the bed rail to the arm.

See Figure 4-10.

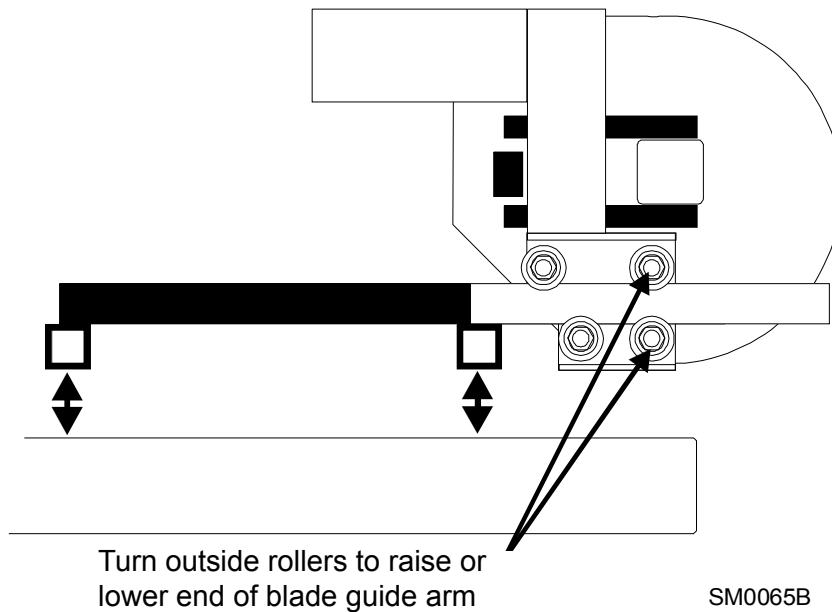

FIG. 4-10

4. Adjust the blade guide arm in to within 1/2" (15 mm) of full closed. Measure again from the top of the bed rail to the arm.
5. Adjust the arm so that the measurement from the top of the bed rail to the arm in the closed position is the same as the measurement from the top of the bed rail to the arm in the open position.

If the arm is too low in the closed position, loosen the lower outside roller and tighten the upper outside roller (See Step 6.)

If the arm is too high in the closed position, loosen the upper outside roller and tighten the lower outside roller (See Step 6.)

6. The rollers are mounted on cam bolts that raise or lower the arm when turned.

To adjust the rollers, locate the cam bolt head inside the housing and turn until the arm is lowered or raised as needed. Recheck the arm in both the open and closed positions. Repeat adjustments until the arm is the same distance from the bed rail in the open and closed position.

7. The blade guide arm should be snug, but not too tight, in the rollers. You should be able to move it in and out with firm hand pressure. There should be no side-to-side play.

## 4.8 Blade Guide Arm Horizontal Adjustment

1. Put the blade guide assembly back in the arm (if you took it out). Put the assembly back so that the flanged collar on the roller is about 1/8" (3.0 mm) from the back of the blade when the throat is 1/2" (15 mm) from full open.
2. Close the throat to within 1/2" (15 mm) from fully closed. Check to see that the flange is the same distance from the back of the blade.

See Figure 4-11.

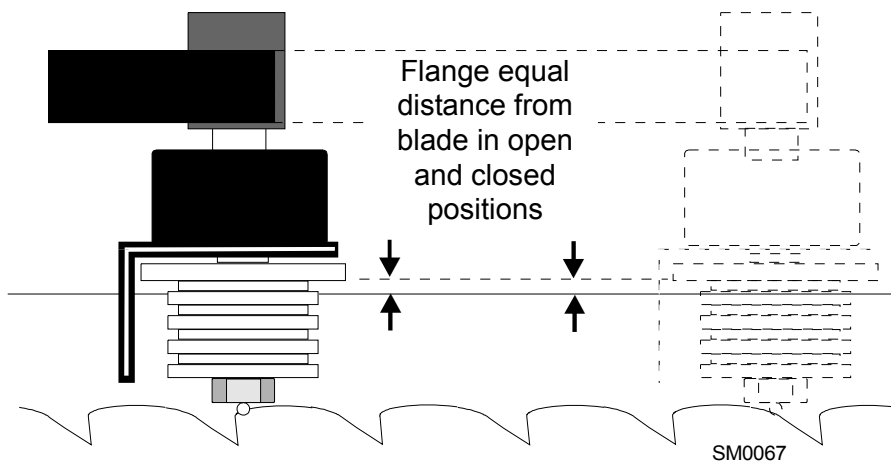
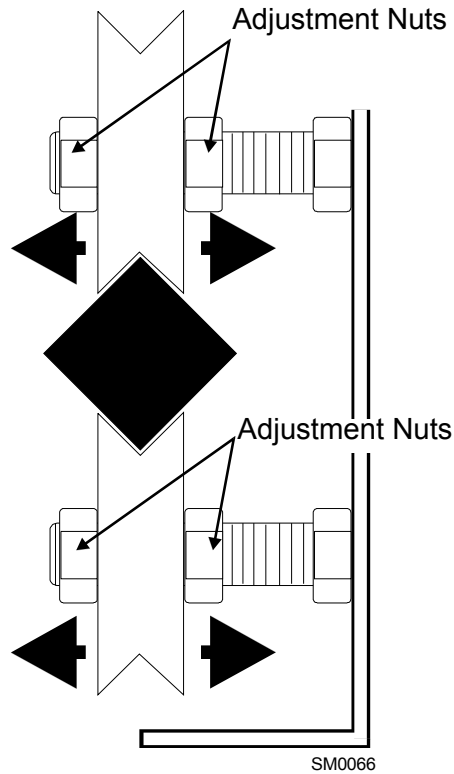

FIG. 4-11



3. If adjustment is needed, the guide rollers can be adjusted in or out on the threaded mounts to open or close the gap.

See Figure 4-12.



**FIG. 4-12**

4. Adjusting the outside two rollers (furthest from the arm motor) inward will cause the flange to move away from the blade.
5. Adjusting the two outside rollers outward will cause the flange to move toward the blade.
6. Adjust until the roller flange is the same distance from the back of the blade in the open and closed position.

## 4.9 Aligning the Blade Guides

Each Wood-Mizer sawmill has two blade guide assemblies that help the blade maintain a straight cut. The two blade guide assemblies are positioned on the saw head to guide the blade on each side of the material being cut.

One blade guide assembly is mounted in a stationary position on the drive side of the saw head. This assembly is referred to as the "inner" blade guide assembly.

The other blade guide assembly is mounted on the idle side of the saw head. It is referred to as the "outer" assembly and is adjustable for various widths of materials to be processed.

Blade guide alignment includes four steps:

- Blade Deflection
- Blade Guide Vertical Tilt
- Blade Guide Flange Spacing
- Blade Guide Horizontal Tilt

Perform the blade guide alignment after you have aligned the blade on the wheels and adjusted the blade and blade guide arm parallel to the bed rails. After blade guide alignment, check the scale indicator to make sure it is adjusted properly ([See Section 4.19](#)).

**NOTE:** During blade guide alignment, remove the blade guide adjusting screws and apply a lubricating oil such as 10W30 or Dexron III to each screw. This will prevent the screws and threaded holes from corroding and make screw adjustments easier.

## 4.10 Blade Deflection

Perform the following steps to achieve proper blade deflection with the blade guides.

1. Raise the carriage until the blade is 15" (375 mm) above a bed rail. Measure the actual distance with a tape from the top of the rail to the bottom of the blade.
2. Install the blade guides. Make sure the two set screws shown are threaded into the blade guide shaft until they touch each other.

See Figure 4-13.

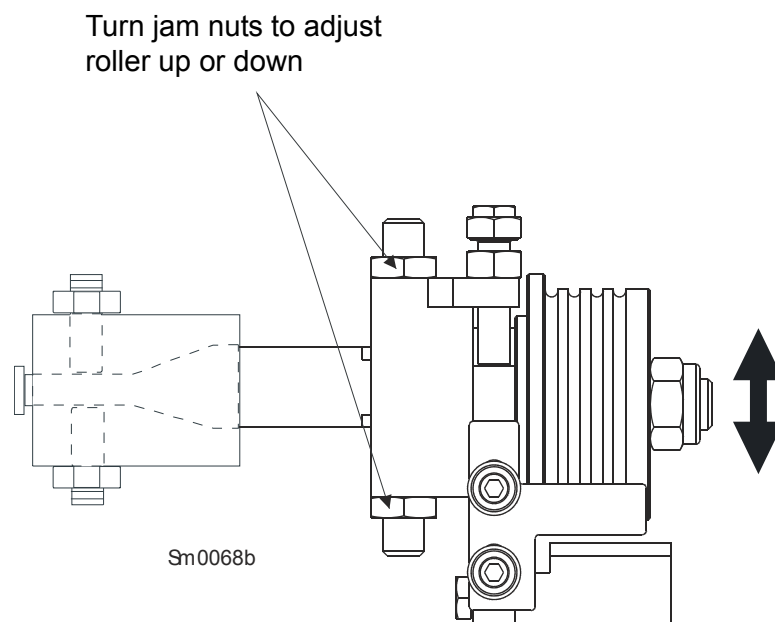

FIG. 4-13

3. Loosen the bottom jam nut and tighten the top jam nut until the blade guide deflects the blade down 4.0 mm.
4. Repeat for the other blade guide.

**NOTE:** Be sure that the blade guide deflector rod clears the blade on both guide assemblies. The rod on the outer guide assembly should be checked with the arm all the way in and all the way out.

## 4.11 Blade Guide Vertical Tilt Adjustment

Check that the blade guide does not tilt the blade up or down. A Blade Guide Alignment Tool (BGAT) is provided to help you measure the vertical tilt of the blade.

1. Open the adjustable blade guide arm 1/2" (15 mm) from full open.
2. Clamp the alignment tool on the blade. Position the tool close to a blade guide roller. Be sure the tool does not rest on a tooth or burr, and is lying flat on the blade.

See Figure 4-14.

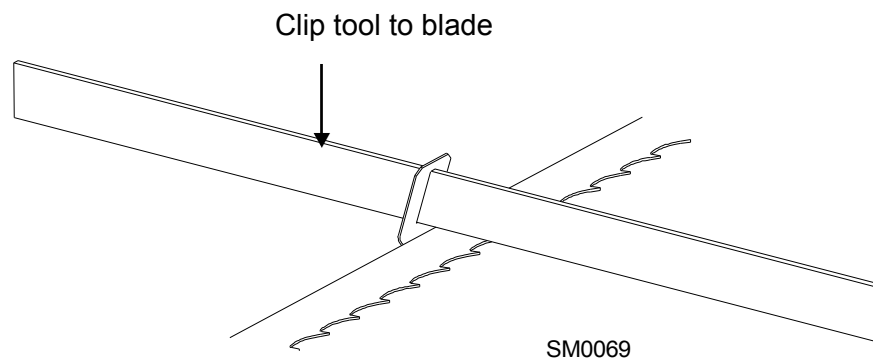

FIG. 4-14

3. Measure the distance from the bed rail to the bottom of the tool.
- NOTE:** If the sawmill is equipped with stainless steel bed rail covers, be sure to measure from the blade guide alignment tool to the top surface of the cover rather than the bed rail tube.
4. Move the carriage so that the front end of the tool is positioned above the bed rail.
  5. Measure the distance from the bed rail to the bottom edge of the tool.
  6. Loosen one set screw at the side of the blade guide assembly.
  7. Use the set screws shown to tilt the blade guide until the measurement from the bed rail to the tool equals the first measurement taken at the center of the tool.

See Figure 4-15.

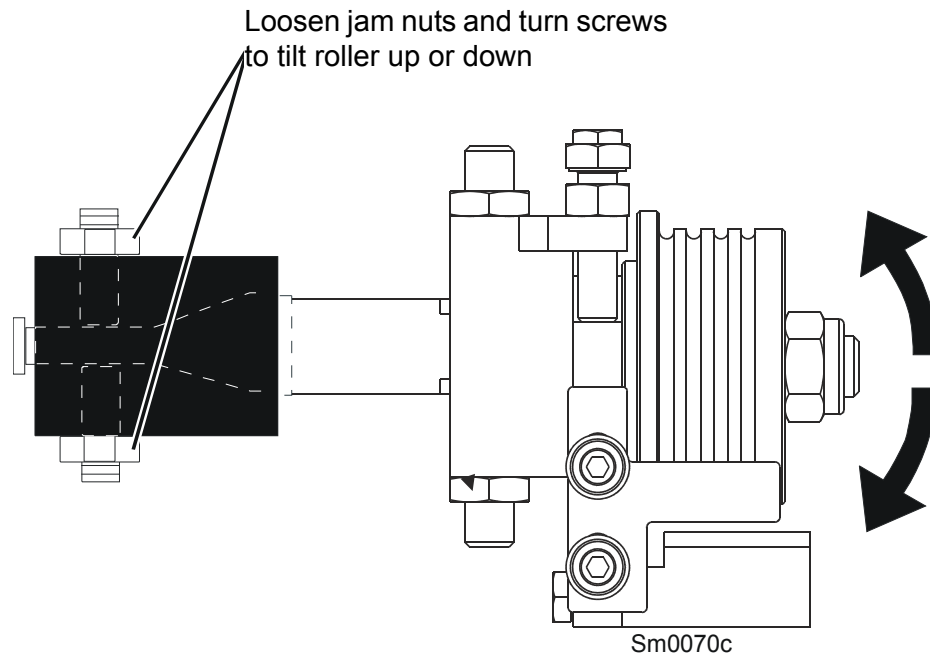

FIG. 4-15

8. Move the carriage forward so the back end of the tool is over the bed rail.
9. Use the set screws shown to adjust the blade guide tilt until the measurement from the bed rail to the tool equals the other two measurements taken.
10. Move the tool close to the other blade guide and repeat the previous steps.

**NOTE:** If major adjustments to blade guide tilt were made, measure the distance between the blade and the bed rails again to ensure the correct 4.0 mm blade guide deflection. Adjust if necessary.

## 4.12 Blade Guide Spacing

**HINT:** When adjusting blade guide spacing, loosen the top set screw and one side set screw only. This will ensure horizontal and vertical tilt adjustments are maintained when the set screws are retightened.

1. Adjust the inner blade guide so the blade guide flange is approximately 3.0 mm from the back of the blade.
2. Loosen one side and one top set screw shown. Tap the blade guide forward or backward until properly positioned.

See Figure 4-16.

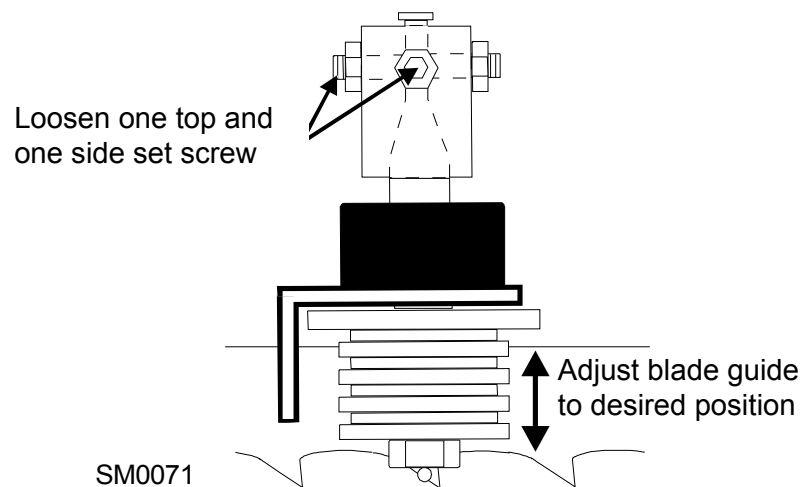

FIG. 4-16

3. Retighten the two set screws.
4. Adjust the outer blade guide in the same way so the blade guide flange is approximately 3.0 mm from the back of the blade.

### 4.13 Horizontal Tilt Adjustment

1. Finally, both blade guides must be tilted horizontally. Adjust the blade guide arm halfway in.

See Figure 4-17.

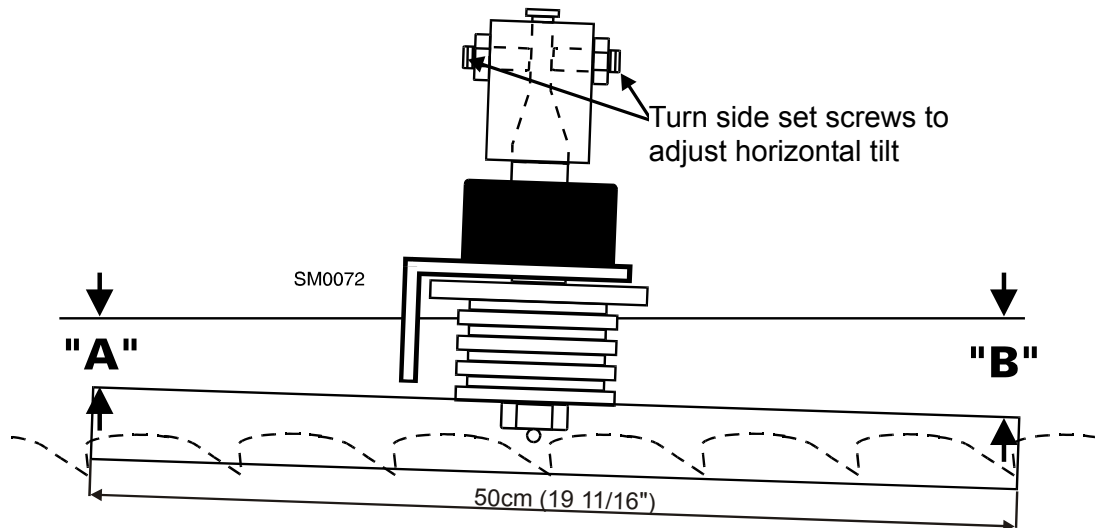

FIG. 4-17

2. Place the Blade Guide Alignment Tool against the face of the outer blade guide roller.
3. Center the tool on the roller and measure between the back edge of the blade and the ruler at the end closest to the inner blade guide ("B").
4. Measure between the back edge of the blade and the other end of the ruler ("A").
5. The roller should be tilted slightly to the left ( $A=B-1.4$ " [6 mm]).
6. Use the side set screws to adjust the horizontal tilt of the roller.
7. Repeat steps 3-7 for the inner blade guide roller.

**NOTE:** Once the blade guides have been adjusted, any cutting variances are most likely caused by the blade. See the **Blade Handbook, Form #600**.

## 4.14 Blade Guide Disc Adjustment

To ensure correct cutting, adjust the gap between the blade guide disc and the blade. Perform the adjustment with the blade installed and properly tensioned.

**See Figure 4-18.** Loosen both nuts and retaining bolts. Use the adjustment bolt to raise or lower the disc until its distance from the blade is 0.3 - 0.5 mm. Then retighten the retaining bolts so that the disc is parallel to the blade. Retighten the retaining bolt nuts.

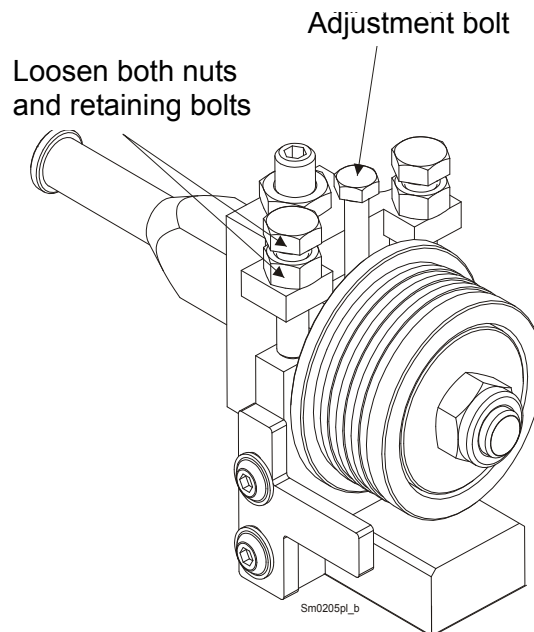

**FIG. 4-18**

**See Figure 4-19.** The gap between the disc and the blade should measure 0.3 - 0.5 mm.

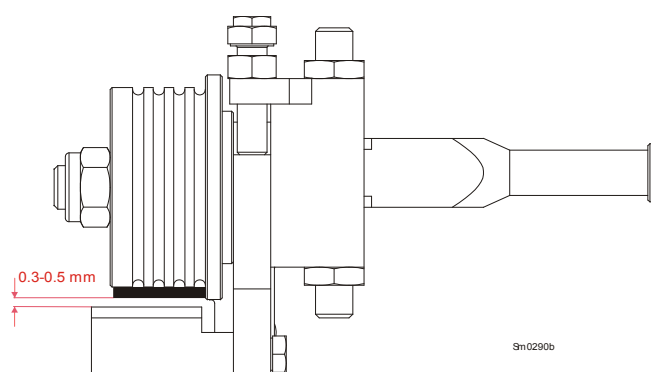

**FIG. 4-19**



## 4.15 Horizontal Adjustment of Side Supports

Logs and boards are clamped against the side supports when sawing. The side supports must be square to the bed to ensure square lumber.

1. Swing the side support down.
2. Measure between the face of the support and the main bed tube. Make measurements at both ends of the side support to make sure that it is parallel to the rail.

See Figure 4-20.

3. Use the two lower bolts to adjust the side support so  $B=A$ .
4. Repeat for remaining side supports.

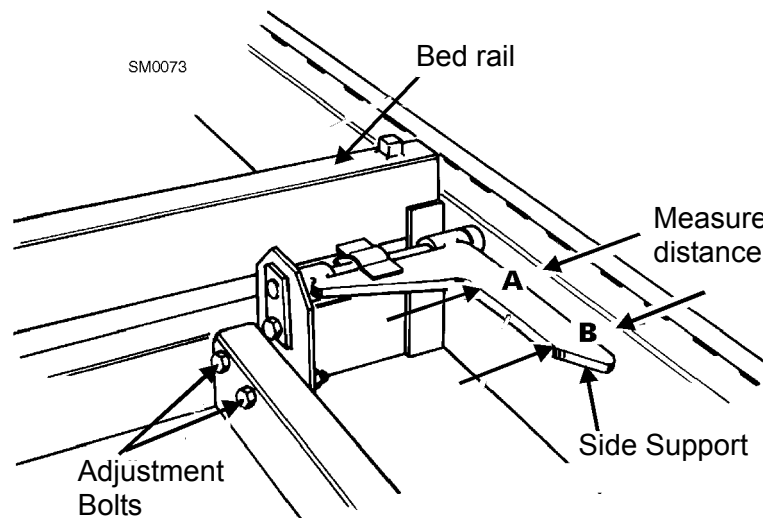

FIG. 4-20

## 4.16 Vertical Adjustment of Side Supports

1. Place a flat board across the bed rails.
2. Swing a side support up so that it is vertical.
3. Pull back at the top of the support to eliminate slack as if a log were being clamped against it.

See Figure 4-21.

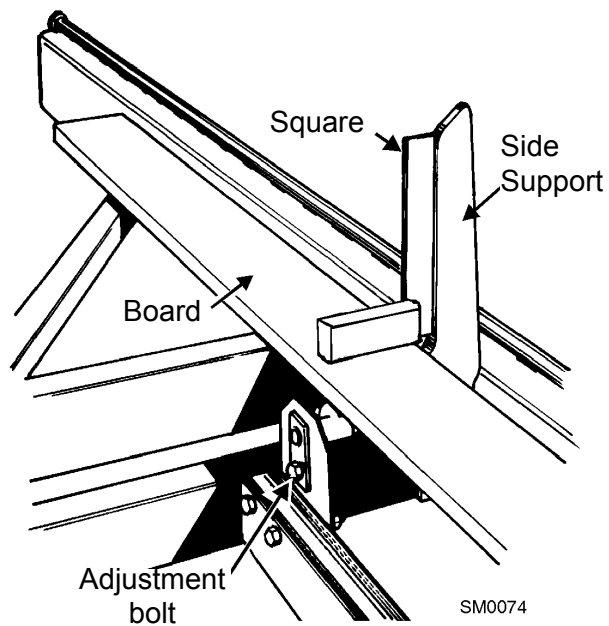

FIG. 4-21

4. Check the angle of each support with a square on the board.
5. The side support should be 90° to the bed rails. Loosen the top adjustment bolt, adjust the side support, and retighten the bolt.
6. Repeat for the remaining side supports.

## 4.17 Clamp Stop/Stop Bolt Adjustment

1. Once the side supports are aligned, pivot them down to their horizontal position.
2. Tie a string across the face of the side supports.

See Figure 4-22.

3. Loosen the clamp stop bolts and adjust the clamp stop until it touches the string. Loosen the jam nut and adjust the bolt on the middle-rear bed rail until it touches the string.

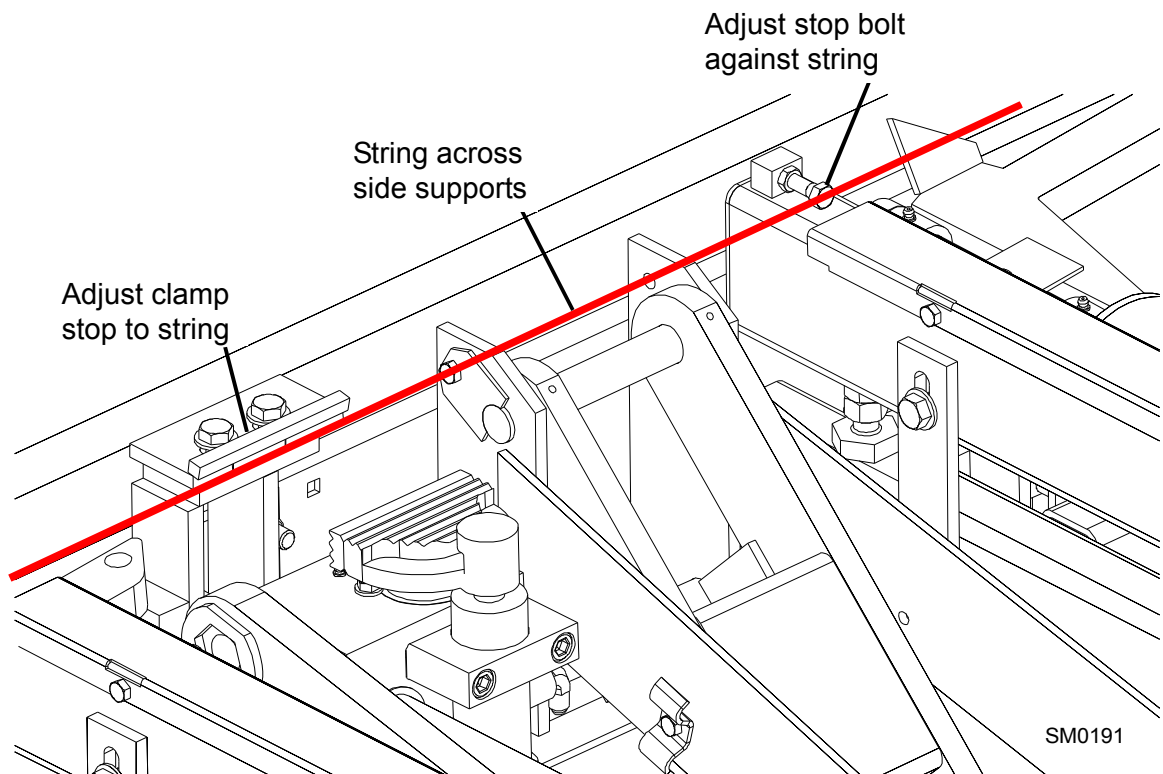

FIG. 4-22

## 4.18 Saw Head Tilt

As the blade enters a wide log or cant, the outside of the saw head will drop down slightly. To compensate for the drop, use the lower track roller horizontal bolts to raise the outside of the saw head  $1/16"$  (1.5 mm).

1. Move the saw head so the blade is positioned  $14 \frac{3}{4}"$  (375 mm) above a bed rail.
2. Adjust the lower track roller horizontal nuts until the blade measures  $14 \frac{13}{16}"$  (376 mm) from the bed rail near the outer blade guide.

See Figure 4-23.

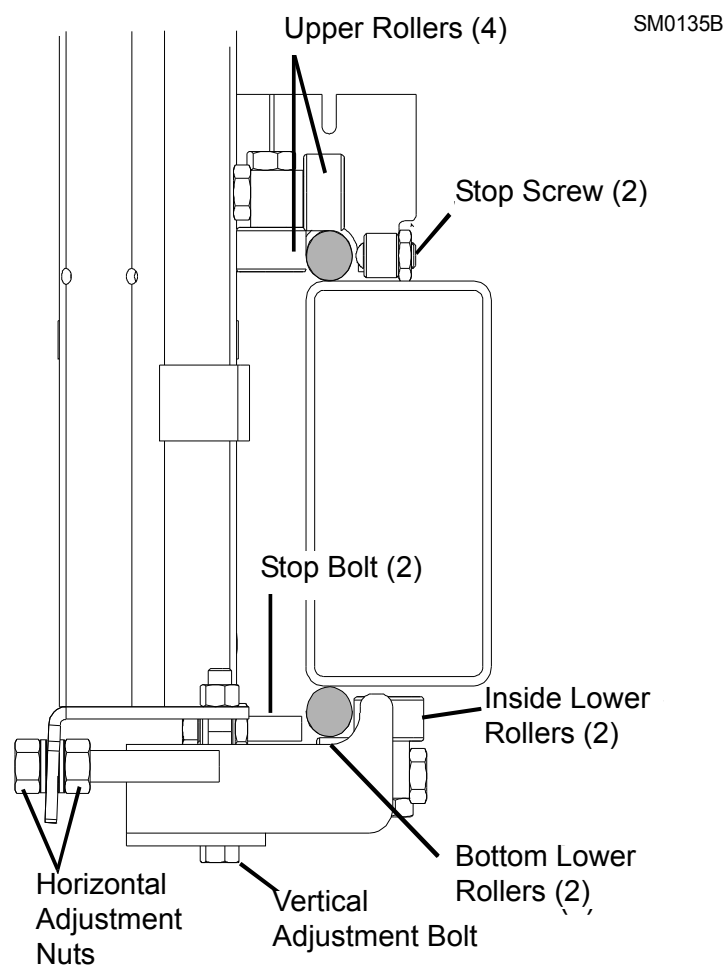

FIG. 4-23

## 4.19 Blade Height Scale Adjustment

After the entire sawmill has been aligned and all adjustments made, check that the blade height scale indicates the true distance from the blade to the bed rails.

1. Move the saw head so the blade is positioned directly above one of the bed rails. Measure from the bottom edge on a down-set tooth of the blade to the top of the bed rail (or stainless steel sleeve if applicable).

See Figure 4-24.

2. View the blade height scale with eyes level with the indicator.

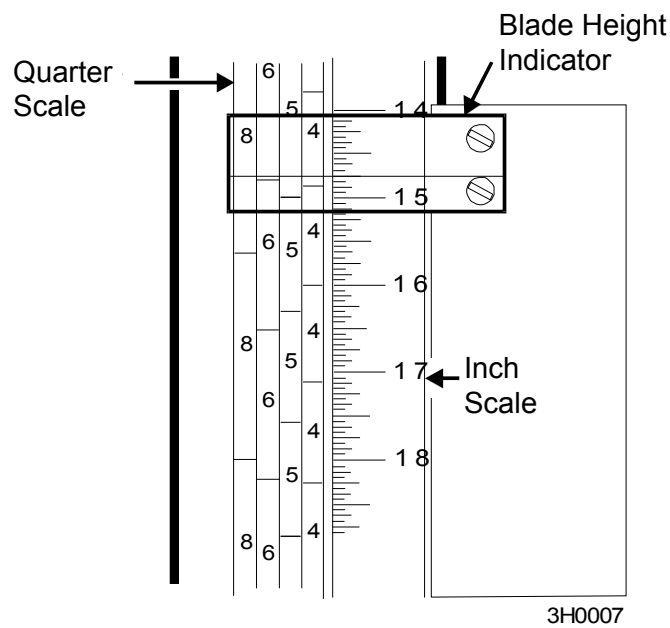

FIG. 4-24

3. Loosen the indicator bracket mounting bolts and adjust the bracket until the indicator is aligned with the correct mark on the scale. Retighten the bracket mounting nut.

For example, if the measurement from blade to bed rail was 14 3/4" (375 mm), make sure the indicator reads 14 3/4" (375 mm) on the scale.

**EC declaration of conformity  
according to EC Machinery Directive 2006/42/EC, Annex II, 1.A**

Manufacturer: Wood-Mizer Industries Sp. z o. o.  
Nagórna 114; 62-600 Koło, Poland

That the following described machine in our delivered version complies with the appropriate basic safety and health requirements of the EC Machinery Directive 2006/42/EC based on its design and type, as brought into circulation by us. In case of alteration of the machine, not agreed by us, this declaration is no longer valid.

Designation of the machine: Sawmill  
Type: LT40  
No. of manufacturer: .....  
Applicable EC Directives: EC Machinery Directive 2006/42/EC  
EC Electromagnetic Compability Directive 2004/108/EC

Applicable Harmonized Standards: PN-EN ISO 12100:2012  
PN-EN 1807-2: 2013-08  
PN-EN ISO 13849-1:2008  
PN-EN 60204-1:2010  
PN-EN ISO13857:2010  
PN-EN ISO 4413:2011

Notified Body according to annex IV: PZ.LSV; Prof- und Zertifizierungsstelle des Spitzenverbandes der landwirtschaftlichen Sozialversicherung

Notification No: 2157

Responsible for: EC type examination

EC type - examination certificate no: LSV-EG-2015/104

Responsible for Technical Documentation: Adam Kubiak / R & D Manager  
Wood-Mizer Industries Sp. z o.o.  
62-600 Koło, ul. Nagórna 114, Poland  
Tel. +48 63 26 26 000

Place / Date / Authorized Signature Koło, 04.02.2015 **Adam Kubiak**

Title: R & D Manager