

user manual

Instrukcja obsługi | Руководство пользователя
Manuel de l'Utilisateur | Betriebsanweisung
Bruksanvisning | Manual del Usuario
Betjeningsvejledning | Gebruikershandleiding
Käyttöohjeet | Manual de utilizare | Bruksanvisning
Manuale d'uso | Příručka uživatele | Navodila
za uporabo

Retain for future use
Zachować do przyszłego użytku
Сохраните для последующего
использования
A conserver pour une utilisation future
Für zukünftige Benutzung aufbewahren
Behold for senere bruk
Säilytä nämä käyttöohjeet tulevaa tarvetta marten
Opbevar manualen til fremtidig brug
Bewaren voor gebruik in de toekomst
Conservare il presente manuale a l'uso futuro
Păstrați acest manual pentru utilizare viitoare
Conservar para futuras consultas
Behall för framtida användning
Uchovajte pro další použití
Hranite za prihodnjo uporabo

Wood-Mizer®

Safety, Setup, Operation & Maintenance Manual

**LT40MAHS
LT40MAHS Wide**

**rev. A6.04
rev. A6.04**



Safety is our #1 concern! Read and understand all safety information and instructions before operating, setting up or maintaining this machine.

Form #1055

**This is the original language
for the manual.**

Table of Contents

Section-Page

SECTION 1	SAFETY & GENERAL INFORMATION	1-1
1.1	Safety Symbols.....	1-1
1.2	Blade Handling.....	1-1
1.3	Sawmill Setup.....	1-2
1.4	Sawmill Operation.....	1-2
1.5	Sawmill Maintenance	1-4
1.6	Belt Sizes	1-12
1.7	Blade Sizes	1-12
1.8	Cutting Capacity.....	1-13
1.9	Motor Specifications	1-14
1.10	Overall Dimensions	1-16
1.11	Chains	1-16
1.12	Hydraulic System	1-17
1.13	Dust Extractor Specifications.....	1-17
1.14	Components.....	1-18
1.15	LT40/70 S/M DH Hydraulic Schematic	1-18
1.16	LT40/70 S/M AH Hydraulic Schematic	1-22
1.17	LT40/70 S/M AH Hydraulic Components	1-23
SECTION 2	SETUP & OPERATION	2-1
2.1	Sawmill Setup.....	2-1
2.2	Stationary Sawmill Setup	2-3
2.3	Sawmills with cable guide.....	2-5
2.4	Portable Sawmill Setup	2-10
2.5	Middle Track Cover	2-13
2.6	Replacing The Blade	2-14
2.7	Tensioning The Blade.....	2-15
2.8	Tracking The Blade	2-16
2.9	Starting The Motor	2-17
2.10	Board Return	2-18
2.11	Hydraulic Control Operation.....	2-21
2.12	Loading, Turning, And Clamping Logs	2-22
2.13	Up/Down Operation	2-25
2.14	Blade Guide Arm Operation.....	2-26
2.15	Power Feed Operation	2-27
2.16	Cutting The Log	2-29
2.17	Edging.....	2-30
2.18	Optional Cutting Procedure for Super Series Mills.....	2-30
2.19	Blade Height Scale	2-31
2.20	Water Lube Operation	2-33
2.21	Preparing The Sawmill For Transportation.....	2-34

Table of Contents

Section-Page

SECTION 3	MAINTENANCE	3-1
3.1	Wear Life.....	3-1
3.2	Blade Guides	3-2
3.3	Sawdust Removal	3-3
3.4	Carriage Track, Wiper & Scrapers	3-4
3.5	Vertical Mast Rails	3-5
3.6	Drum Switches	3-5
3.7	Miscellaneous	3-5
3.8	Blade Tensioner.....	3-6
3.9	Blade Wheel Belts	3-7
3.10	Drive Belt Adjustment.....	3-7
3.11	Drive Bearing	3-8
3.12	Up/Down System.....	3-9
3.13	Power Feed	3-11
3.14	Safety Devices Inspection	3-13
3.15	Adjusting the Air Gap of the Up/Down Motor Brake.....	3-15
SECTION 4	TROUBLESHOOTING GUIDE	4-1
4.1	Sawing Problems	4-1
4.2	Electrical Problems.....	4-3
4.3	Power Feed Problems	4-5
4.4	Hydraulic Problems	4-7
4.5	Motor and Drive Pulleys Alignment	4-11
4.6	Power Feed Variable Speed Switch Test.....	4-11
4.7	Power Feed Preliminary Test	4-11
4.8	Power Feed Mechanical Test.....	4-11
SECTION 5	SAWMILL ALIGNMENT	5-1
5.1	Pre-Alignment Procedures.....	5-1
5.2	Frame Setup.....	5-2
5.3	Blade Installation And Alignment.....	5-3
5.4	Saw Head Slide Pad Adjustment.....	5-6
5.5	Adjusting The Lower Track Rollers.....	5-7
5.6	Adjusting Bed Rails To The Blade.....	5-10
5.7	Blade Guide Arm Alignment.....	5-13
5.8	Blade Deflection	5-19
5.9	Blade Guide Vertical Tilt Adjustment.....	5-20
5.10	Blade Guide Spacing	5-22
5.11	Horizontal Tilt Adjustment.....	5-23
5.12	Blade Guide Disc Adjustment	5-24
5.13	Horizontal Adjustment of Side Supports.....	5-25
5.14	Vertical Adjustment of Side Supports	5-26
5.15	Vertical Adjustment of Side Supports.....	5-27

Table of Contents

Section-Page

5.16	Clamp Stop/Stop Bolt Adjustment	5-28
5.17	Vertical Adjustment of Side Supports (Super Hydraulic Sawmill Only)	5-29
5.18	Saw Head Tilt.....	5-30
5.19	Blade Height Scale Adjustment.....	5-31
SECTION 6 MOTOR BRAKE		6-1
6.1	Motor Brake Maintenance.....	6-1

Table of Contents

Section-Page

This manual is to replace or to be used with all previous information received on the Wood-Mizer®* sawmill. All future mailings will be an addition to or a revision of individual sections of this manual as we obtain new information.

The information and instructions given in this manual do not amend or extend the limited warranties for the equipment given at the time of purchase.

*Wood-Mizer® is a registered trademark of Wood-Mizer Products, Inc.

Sawmill and Customer Identification

Each Wood-Mizer sawmill has a 17-digit Vehicle Identification Number (VIN). See the figure below for VIN locations. See the chart for VIN description.

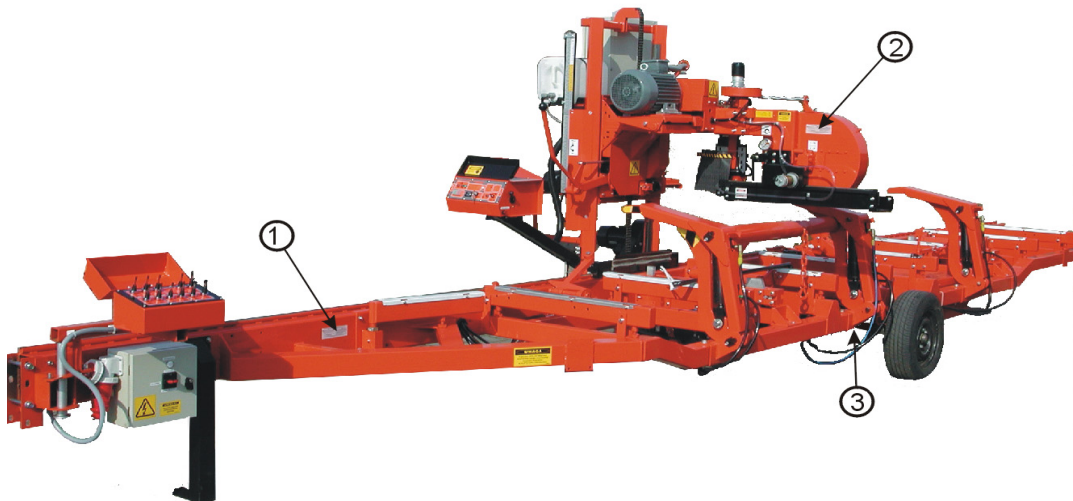

V.I.N. LOCATIONS

456	A	4	24	1	X	J	N	A	F9	017	F9	.01
<p>Company Identification Number 456=Wood-Mizer Indiana</p> <p>Weight Class; A=Under 1300 kg, B=1301-1800 kg, C=1801-2200 kg, D=2201-3000kg, X- Stationary.</p> <p>Product No.; 1=LT10/15, 2=LT20 Series, 4=LT40 Series, 7=LT70 Series</p> <p>Length of the Trailer; 20= 20' (6 m), 24=24' (7 m), 35=35' (11 m)</p> <p>Number of axles on the trailer</p> <p>Check Digit Add all the number and divide by 11</p> <p>Year of Manufacture; N=2015, P=2016, R=2017, S=2018, T=2019</p> <p>State of Manufacture N=Indiana, P=Poland</p> <p>Month of Manufacture A=January, B=February, C=March, etc...</p> <p>Revision Level</p> <p>Sequence Number Ranging from 000-999</p> <p>End of 17-Digit VIN</p> <p>Revision Level (Repeated)</p> <p>Two-Digit Minor Revision Level</p>												

V.I.N. DESCRIPTION

Each sawmill is also identified with a model number which includes the base model and the engine/motor configuration. See the figure for a description of the model number.



MODEL NUMBER DESCRIPTION.

When you pick up your mill, you will receive a customer number. Both the VIN and your customer number expedite our service to you. Please write these numbers below so you have quick, easy access to them.

Customer No.	Model No.	V.I.N.	Revision

Table of Contents

Section-Page

Getting Service

Wood-Mizer is committed to providing you with the latest technology, best quality and strongest customer service available on the market today. We continually evaluate our customers' needs to ensure we're meeting current wood-processing demands. Your comments and suggestions are welcome.

General Contact Information

From Europe call your local distributor or our European Headquarters and Manufacturing Facility in Koło, Nagórna 114 St, Poland at **+48-63-2626000**. From the continental U.S., call our U.S. Headquarter 8180 West 10th St. Indianapolis, IN 46214, toll-free at **1-800-525-8100**. Ask to speak with a Customer Service Representative. Please have your machine identification number and your customer number ready when you call. The Service Representative can help you with questions about the operation and maintenance of your machine. He also can schedule you for a service call.

Office Hours:

Country	Monday - Friday	Saturday	Sunday
Poland	7 a.m.- 3 p.m.	Closed	Closed
US	8 a.m.- 5 p.m.	8 a.m.- 12 p.m	Closed

Please have your vehicle identification number and your customer number ready when you call.

Wood-Mizer will accept these methods of payment:

- Visa, Mastercard, or Discover
- COD
- Prepayment
- Net 15 (with approved credit)



Be aware that shipping and handling charges may apply. Handling charges are based on size and quantity of order.

Technical data are subject to change without prior notice.

Actual product may differ from product images. Some illustrations show machines with optional equipment.

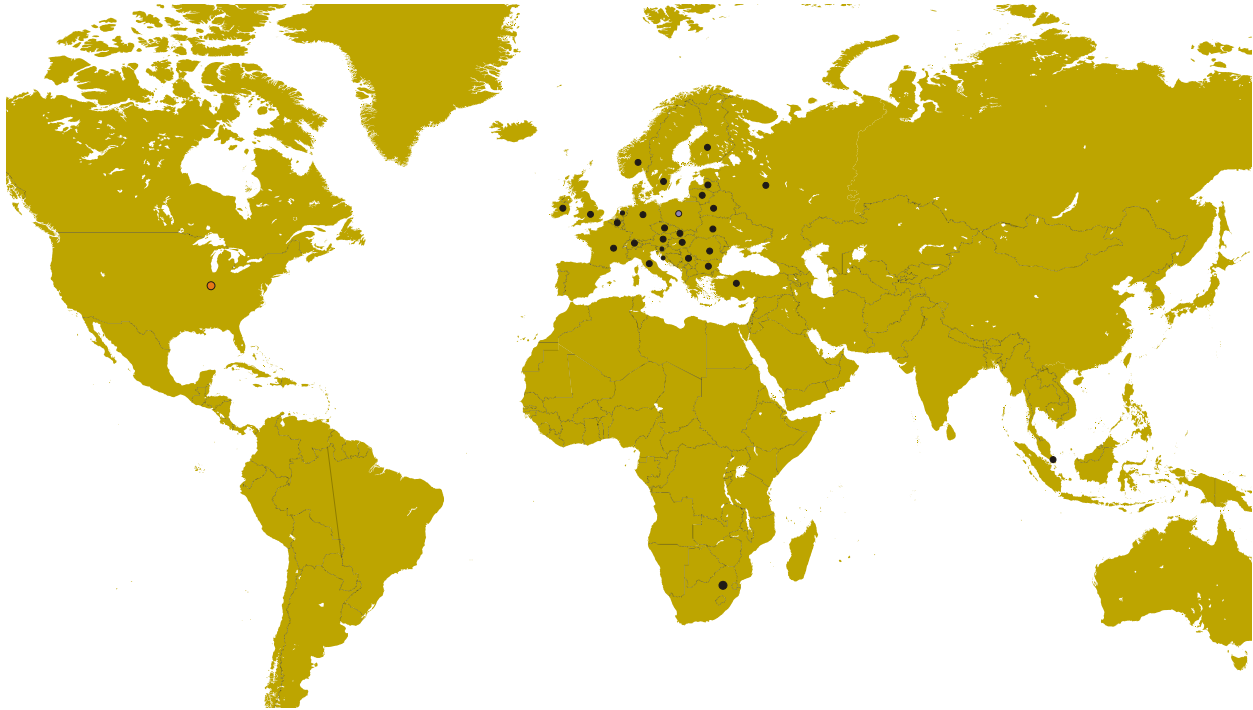
Branches & Authorized Sales Centers Wood-Mizer Locations (North and South America)



EUROPE		UNITED STATES
<p> European Headquarters Wood-Mizer Industries Sp. z o.o. Nagórna 114, 62-600 Kolo, Poland Tel.: +48-63-26-26-000 Fax: +48-63-27-22-327 www.woodmizer.eu</p>		<p> World Headquarters Wood-Mizer LLC 8180 West 10th Street Indianapolis, Indiana 46214-2400, USA Tel.: +1-317-271-1542 Fax: +1-317-273-1011 www.woodmizer.com</p>
<p>BELARUS MOST-GRUPP Siemashko 15, k.3 Minsk 2200116 Tel.: +375-17-270-90-08 Fax: +375-17-270-90-08 GSM: +375-29-649-90-80 e-mail: most-by@mail.ru</p>	<p>SWITZERLAND Stefan Wespi Maschinen u. Geräte Spezialarbeiten GmbH Eichstraße 4 6353 Weggis Tel.: +41-413-900-312 GSM: +41-799-643-594 info@woodmizer.ch www.woodmizer.ch</p>	<p>RUSSIA Dariusz Mikołajewski OOO WOOD-MIZER INDUSTRIES 141031, Moscow Reg., Mytishenski raj., pos. Veshki, Zavodskaja str., 3B Tel.Fax: +7(495) 788-72-35 Tel.Fax: +7(495) 641-51-60 e-mail: dariuszm@woodmizer-moscow.ru</p>
<p>BULGARIA Kalin Simeonov Ecotechproduct 38 Star Lozenski pat str. Sofia 1186 Tel.: +359-2-462-7035 Tel.: +359-2-963-1656 Tel./Fax : +359-2-979-1710 Kalin Simeonov GSM: +3592-963-2559 e-mail: office@ecotechproduct.com</p>	<p>HUNGARY Wiktor Turoczy Wood-Mizer Hungary K.F.T. Szonyi Ut 67., 2921 Komárom Tel./Fax: +36-34-346-255 e-mail: woodmizer@woodmizer.hu</p>	<p>RUSSIA Far East Wladimir Glazaczew "WM Service" Krasnoretchenskaya Str.111 680006 Khabarovsk Tel./Fax: +7-914-541-1183 e-mail: wms-khv@mail.ru</p>

<p>CROATIA Krešimir Pregernik Pregimex d.o.o. S. Batušića 31, 10090 Zagreb Tel./Fax: +3851-38-94-668 Krešimir Pregernik GSM: +3851-98-207-106 e-mail: Kresimir.Pregernik@gmail.com</p>	<p>ITALY Pasquale Felice Wood-Mizer Italia Srl Cda. Capoiaccio SN 86012 Cercemaggiore Campobasso Tel./Fax: +39-0874-798-357 GSM: +39-333-281-03-79 e-mail: wmitaliasrl@gmail.com</p>	<p>SERBIA Dragan Markov Wood-Mizer Balkan d.o.o. Svetosavska GA 3/3; P. Fah 25 23 300 Kikinda Tel./Fax: +381-230-25-754 Tel./Fax: +381-230-23-567 GSM: +381-63-568-658 e-mail: office@woodmizer.co.yu</p>
<p>CZECH REPUBLIC Miroslav Greill Wood-Mizer CZ s.r.o. Za Kasárny 946 339 01 Klatovy Tel: +420-376-312-220 GMS: +420-608-111-104 Miroslav Greill GMS: + 420-602-439-799 E-mail: woodmizer@woodmizer.cz</p>		<p>SLOVAKIA Wiktor Turoczy Wood-Mizer Danubia s.r.o. Hadovce 5, 94501 Komárno Tel.: +421-35-77-40-316 Fax: +421-35-7740-326 GSM: +421-905-930-972 e-mail: woodmizer@woodmizer.sk</p>
<p>CZECH REPUBLIC Lubomir Kudlik Wood-Mizer Moravia Sovadinova 6 69002 Breclav Tel./Fax: +420-519-322-443 Lubomir Kudlik GSM: +420-602-734-792 e-mail: info@wood-mizer.net</p>	<p>LATVIA Vilmars Jansons OBERTS Ltd Gaujas str. 32/2 LV-2167 Marupe, Rigas Raj. Tel.: +371-7-810-666 Fax: +371-7-810-655 Vilmars Jansons GSM: +371-92-06-966 Andris Orols GSM: +371-28-33-07-90 e-mail: andris@oberts.lv</p>	<p>TURKEY Er-Ka Ahsap Profil Kerestecilik San. ve Tic. Ltd. Sti. Adana Keresteciler Sitesi 191 sk No.41 ADANA Tel.: +90-322-346-15-86 Fax: +90-322-345-17-07 GSM: +90-533-363-18-44 e-mail: info@erkaahsap.com.tr</p>
<p>FINLAND Howard Blackbourn Oy Falkberg Jordbruk Ab Falkintie 220 25610 Ylonkyla Tel.: +358-2732-2253 Fax: +358-2732-2263 Howard Blackbourn GSM: +358-440-424-339 e-mail: falkberg@woodmizer.fi</p>	<p>LITHUANIA Andrius Zuzevicius UAB Singlis Savanoriu pr. 187, 2053 Vilnius Tel.: +370-5-2-32-22-44 Fax: +370-5-2-64-84-15 GSM: +370-620-28-645 e-mail: andrius.z@singlis.lt Dmitrij Gaiduk GSM: +370-69-84-51-91 e-mail: dmitrijus.g@singlis.lt</p>	<p>UKRAINE Ivan Vinnicki MOST UKRAINA bul. Myru 3, Bajkivtsi Ternoplskyj r-j Ternopolska oblast 47711 Ukraine Tel/Fax: +38 (0352) 52 37 74 GSM: +38 (067) 352 54 34 GSM: +38 (067) 674 50 68 E-mail: most-ukraine@ukr.net</p>
<p>FRANCE Tizoc Chavez Wood-Mizer France 556 chemin des Embouffus, ZAC des Basses Echarrieres 38440 SAINT JEAN DE BOURNAY Tel: +33-4 74 84 84 44 GSM: +33-607 52 02 82 Mail: tchavez@woodmizer.fr</p>	<p>NORWAY Tor Bakken Flaathe Bakken Flaathe A/S Løkenvegen 5, 2034 Holter Tel: + 47-638 74 989 Sales: + 47- 412 80 076 Service: +47- 975 87 588 post@woodmizer.no www.woodmizer.no</p>	<p>UNITED KINGDOM & IRELAND Wood-Mizer UK Hopfield Barn Kenward Road, Yalding Kent ME18 6JP, UK Tel.: +44-1622-813-201 Fax: +44-1622-815-534 e-mail: info@woodmizer.co.uk</p>
<p>SLOVENIA Jan Fale FAMTEH d.o.o. Gacnikova pot 2, 2390 Ravne na Koroskem Tel.: +386-2-62-04-232 Fax: +386-2-62-04-231 Jan Fale GSM: +386-2-62-04-230 e-mail: jan.fale@famteh.si Matjaz Kolar Tel.: +386-2-62-04-232 GSM: +386-31-775-999 e-mail: matjaz.kolar@famteh.si</p>		

<p>GERMANY/AUSTRIA Klaus Longmuss Wood-Mizer GmbH Dorfstraße 5, 29485 Schletau Büro Tel: +49-5883 988 010 Werkstatt Tel: +49-5883 988 220 Ersatzteilservice Tel: +49 58 83 - 98 80 250 Schärfservice Tel: +49-58 83 - 98 80 270 E-mail: info@woodmizer.de www.woodmizer.de Klaus Longmuss Tel.: +49-5883-9880-12 GSM: +49-17-298-55-892 e-mail: KLongmuss@woodmizer.de</p>	<p>Subagent: SWEDEN Kjell Larsson Mekwood AB Slingan 14, 812 41 Gästrike-Hammarby Tel.: +46-290-515-65 Kjell Larsson GSM: +46-706-797-965 e-mail: kjell.larsson@mekwood.se</p>	<p>IRELAND Wood-Mizer Ireland Stephen Brennan Cum Lahardane Ballina County Mayo Tel:+353 96 51345 E-mail: brennanmill@ericom.net</p>
<p>Subagents: DENMARK Kevin Christiansen Kevin Christiansen's savværker PMV Arnborgvej 40, 7330 Brande- Fasterholt Mobile: +45 61468763 Mobile: +45-23495828 Info@woodmizer.dk www.woodmizer.dk</p>	<p>ROMANIA Adrian Echert SC WOOD-MIZER RO SRL TRANSILVANIEI Nr. 5 Sibiu, Cisanadie 555300 Tel./Fax: : +40-369-405-433 GSM: +40-745-707-323 e-mail: aechert@woodmizer.ro</p>	<p>Regional Manager - Asia Robert Moxham Regional Direction - Asia Wood-Mizer Asia Manufacturing Co., Ltd. No.2, Gongyequ 40th Rd. Xitun District, Taichung City, 40768, Taiwan, R.O.C. TEL: +886-4-2359 3022 FAX: +886-4-2359 3205 CELL: +886-9-0568 7708 EMAIL: RMoxham@woodmizer.com www.woodmizerasia.com Skype: r.g.moxham</p>
<p>NETHERLANDS Gerlo Breukers Breukers Houtzagerij en Bosbouwmachines Hazenweg 5, 7481 PC Haaksbergen Tel: +31-535741326 Mobile: +31-620419412 info@woodmizer.nl www.woodmizer.nl</p>	<p>Subagent: ROMANIA M. Echert S.C. Echert Comprod s.r.l Str. Schitului Nr. 6, Apt.7 etajul-1 725 70 Vatra Dornei, Romania Tel./Fax: +40-230-374-235 Tel. : +40-740-35-35-74</p>	<p>Regional Manager - Africa Gavin Prowse Regional Sales Director - Africa Wood-Mizer Africa (Pty) Ltd. Unit 1, Leader Park 20 Chariot Street Stormill Ext.5 Maraisburg, Johannesburg South Africa TEL: +27 11 473 1313 FAX: +27 11 473 2005 CELL: +27 71 398 8010 EMAIL: growse@woodmizer.com www.woodmizerafrika.com Skype: gavin.prowse</p>

USA World Headquarters

Serving North & South America, Oceania, East Asia

Wood-Mizer LLC
8180 West 10th Street
Indianapolis, IN 46214

Phone: 317.271.1542 or 800.553.0182
Customer Service: 800.525.8100
Fax: 317.273.1011
Email: infocenter@woodmizer.com

Brazil Headquarters

Serving Brazil

Wood-Mizer do Brasil
Rua Dom Pedro 1, No: 205 Bairro: Sao Jose
Ivoti/RS CEP:93.900-000

Tel: +55 51 9894-6461/ +55 21 8030-3338/ +55 51 3563-4784
Email: info@woodmizer.com.br

Canadian Headquarters

Serving Canada

Wood-Mizer Canada
396 County Road 36, Unit B
Lindsay, ON K9V 4R3

Phone: 705.878.5255 or 877.357.3373
Fax: 705.878.5355
Email: ContactCanada@woodmizer.com

Europe Headquarters

Serving Europe, Africa, West Asia

Wood-Mizer Industries Sp z o.o.
Nagorna 114
62-600 Kolo, Poland

Phone: +48.63.26.26.000
Fax: +48.63.27.22.327

Branches & Authorized Sales Centers

For a complete list of dealers, visit www.woodmizer.com

SECTION 1 SAFETY & GENERAL INFORMATION

1.1 Safety Symbols

The following symbols and signal words call your attention to instructions concerning your personal safety. Be sure to observe and follow these instructions.

 The word **DANGER** indicates an imminently hazardous situation which, if not avoided, will result in death or serious injury.

 **WARNING** suggests a potentially hazardous situation which, if not avoided, could result in death or serious injury.

 **CAUTION** refers to potentially hazardous situations which, if not avoided, may result in minor or moderate injury to persons or equipment.

 Warning stripes are placed on areas where a single decal would be insufficient. To avoid serious injury, keep out of the path of any equipment marked with warning stripes.

Read and observe all safety instructions before operating this equipment! Also read any additional manufacturer's manuals and observe any applicable safety instructions including dangers, warnings, and cautions.

Always be sure that all safety decals are clean and readable. Replace all damaged safety decals to prevent personal injury or damage to the equipment. Contact your local distributor, or call your Customer Service Representative to order more decals.

IMPORTANT! It is always the owner's responsibility to comply with all applicable federal, state and local laws, rules and regulations regarding the ownership, operation and towing of your Wood-Mizer sawmill. All Wood-Mizer mill owners are encouraged to become thoroughly familiar with these applicable laws and comply with them fully while using or towing the mill.

Always properly dispose of all sawing by-products, including sawdust and other debris, coolant, oil, fuel, oil filters and fuel filters.

Safety instructions are listed in this section by the following operations:

- Blade Handling
- Sawmill Setup
- Sawmill Operation
- Sawmill Maintenance

1.2 Blade Handling

 **DANGER!** Always disengage the blade and shut off the sawmill engine before changing the blade. Failure to do so may result in serious injury.



WARNING! Always wear gloves and eye protection when handling bandsaw blades. Changing blades is safest when done by one person! Keep all other persons away from area when coiling, carrying or changing a blade. Failure to do so may result in serious injury.



WARNING! Do not spin the blade wheels by hand. Failure to do so may result in serious injury.

1.3 Sawmill Setup



WARNING! Chock the trailer wheels to prevent movement before unhitching it from the towing vehicle. Failure to do so will result in serious injury or death.

WARNING! Put front outrigger down before moving cutting head from the rest position. Failure to do so may result in serious injury.

WARNING! Securely fasten the feet of a stationary sawmill to the floor before operating the sawmill. Failure to do so will result in serious injury or death.

WARNING! Always make sure the trailer is supporting the sawmill frame when operating a sawmill with adjustable outriggers. Failure to do so will result in serious injury or death. The adjustable outriggers are intended to support the saw frame with assistance from the trailer.

WARNING! Do not set up the mill on ground with more than a 10 degree incline. If setup on an incline is necessary, put blocks under one side of the mill or dig out areas for outrigger legs to keep mill level. Setting up the mill on an incline could cause it to tip over, resulting in serious personal injury.



CAUTION! Changes in temperature could cause increased pressure in the blade tensioner and loss of fluid from the gauge. Release the blade tension when the mill is not in use to avoid damage to the tensioner.



CAUTION! Dismount hydraulic log turner leg before transportation in mobile sawmills.

1.4 Sawmill Operation



DANGER! Make sure all guards and covers are in place and secured before operating or towing the sawmill. Failure to do so may result in serious injury.

Be sure the blade housing and pulley covers are closed.

DANGER! Always keep hands away from moving bandsaw blade. Failure to do so may result in serious injury.

DANGER! Stay clear of the area between the trailer axle and saw carriage. Failure to do so may result in serious injury.

DANGER! Keep all persons out of the path of moving equipment and logs when operating sawmill or loading and turning logs. Failure to do so may result in serious injury.

DANGER! Maintain a clean and clear path for all necessary movement around the mill and lumber stacking areas. Failure to do so may result in serious injury.

DANGER! Always be sure the blade is disengaged and all persons are away from the blade before starting the engine. Failure to do so may result in serious injury.

DANGER! Keep all persons out of the path of returning boards. Failure to do so may result in serious injury.



WARNING! Always disengage the clutch/brake mechanism whenever the sawmill is not cutting. Failure to do so may result in serious injury.

WARNING! Always wear eye, ear, respiration, and foot protection when operating the sawmill. Failure to do so may result in serious injury.

WARNING! Be sure the power feed switch is in the neutral position before turning the key switch to the on (#1) or accessory (#3) position. This prevents accidental carriage movement which may cause serious injury or death.



WARNING! Secure all loose clothing and jewelry before operating the sawmill. Failure to do so will result in serious injury or death.

WARNING! Always make sure log is clamped securely before sawing. Failure to do so will result in serious injury or death.

WARNING! Always leave loading arm halfway up while log is on sawmill bed. Failure to do so will result in serious injury or death.

WARNING! The automatic board return is intended to assist a second operator in removing boards quickly. Do not use the board return when operating the sawmill alone. Failure to do so will result in serious injury, death or damage to the equipment.

WARNING! Never use the board return table as a platform to stand on. This table is designed and intended to assist in the removal of boards only. Standing on the table may result in serious injury.

WARNING! Use ONLY water with the water lube accessory. Never use flammable fuels or liquids. If these types of liquids are necessary to clean the blade, remove it and clean with a rag. Failure to do so will result in serious injury or death.



CAUTION! Be sure the pivot rails, turning arm, clamp, and toe boards are below bed level before loading a log onto the bed. Failure to do so may result in machine damage or cause misalignment.

CAUTION! Before loading a log, be sure the cutting head is moved far enough forward so the log does not hit it. Damage to the sawmill may

result.

CAUTION! Always make sure the engine is running before operating the hydraulic controls. Operating the controls without the engine running will result in power drainage from the battery. Holding the hydraulic switches halfway up or down also will cause excessive drainage from the battery.

CAUTION! Do not try to force the saw head beyond its upper and lower travel limits. Damage to the up/down system may result.

CAUTION! Always make sure the up/down switch moves to the neutral or off position when released to ensure that the saw head stops moving. Damage to the sawmill may result.

CAUTION! Move the hydraulic clamp and turner to provide maximum ground clearance before towing. Failure to do so may result in damage to the sawmill.

CAUTION! Be sure to stop the blade when returning the carriage. This will not only prevent the blade from being pulled off and ruined by a wood sliver, but also will increase the life of the blade.

1.5 Sawmill Maintenance



WARNING! Always secure the cutting head with a chain or a brace before adjusting the up/down chain. The cutting head may fall, causing severe injury or death.

WARNING! Always secure the cutting head with a chain or a brace before removing the up/down motor belt. The cutting head may fall, causing severe injury or death.

WARNING! Drum switch grease contains Petroleum Hydrocarbon Lubricant. Eye and skin irritant. If introduced into eyes, flush with water for at least 15 minutes. If film or irritation persists, seek medical attention. Wash skin with soap and water. If ingested, do not induce vomiting - contact a physician. KEEP OUT OF THE REACH OF CHILDREN.



CAUTION! Do not over-grease the blade guide bearings. Over-greasing will push the seals out of the bearings causing premature failure.

CAUTION! Reinstall the track wiper so that it lightly touches the track rail. If the wiper presses too firmly against the rail, it can cause the power feed to bind.

CAUTION! Never use grease on the mast rails as it will collect

sawdust.

CAUTION! Do not use chain lube. It causes sawdust buildup in chain links.

CAUTION! Do not over-tension the up/down chain. Over-tensioning may lead to early failure of the gear reducer.

CAUTION! Do not overtighten the feed chain. Damage to the power feed motor may result.







CAUTION! Do not overtighten the contact set screws on the hydraulic valve assembly. Overtightening may cause the threads in the screw hole to strip.

CAUTION! It is important that the lower stop bolts are properly adjusted to secure the carriage on the track rail. Failure to properly adjust the stop bolts can cause saw head damage, especially during mill transportation.

CAUTION! Pressure should not exceed 2000 psi. If it does, the amp draw will rise above the design maximum of 200 amps, and could cause battery and system problems. Pressure above 2000 p.s.i. may also damage the hydraulic hoses.

CAUTION! Failure to remove sawdust buildup from the battery box lid and/or track rail cover could result in damage to these parts when the saw head is lowered to its lowest position.

Pictogram decals used to warn and inform the user about danger in the LT40:

 <p>086095</p>	<p>Carefully read operator's manual before handling the machine. Observe instructions and safety rules when operating</p>
 <p>086096</p>	<p>Stay clear of hot surfaces</p>
 <p>086096</p>	<p>Do not open or remove safety shields while engine is running</p>
 <p>086098</p>	<p>Do not open or remove safety shields while engine is running</p>
	<p>Close shields and guards prior to operating the machine</p>

PICTOGR

See Table 1-1.

TABLE 1-1

Decal View	W-M No.	Description
------------	---------	-------------

TABLE 1-1



 <p>096317</p>	<p>096317</p>	<p>CAUTION! Read thoroughly the manual before operating the machine. Observe all safety instructions and rules when operating the sawmill.</p>
 <p>099220</p>	<p>099220</p>	<p>CAUTION! Close all guards and covers before starting the machine.</p>
 <p>099219</p>	<p>099219</p>	<p>Blade tension. Turning the bolt clockwise will increase the blade tension and turning the bolt counterclockwise will decrease the tension.</p>

TABLE 1-1



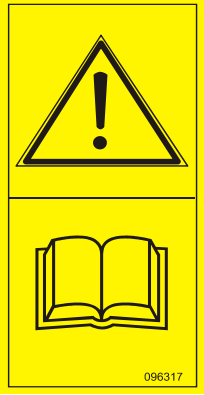

	<p>099223</p>	<p>Blade tension - See manual.</p>
	<p>099221</p>	<p>CAUTION! Keep all persons a safe distance away from work area when operating the machine.</p>
	<p>098176</p>	<p>CAUTION! Keep away from debarker blade!</p>
	<p>099222</p>	<p>CAUTION! Sawdust outlet. Protect eyes!</p>

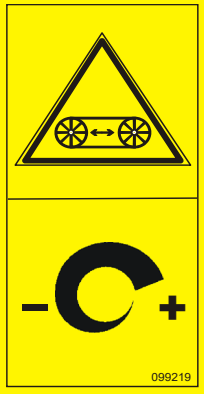
TABLE 1-1

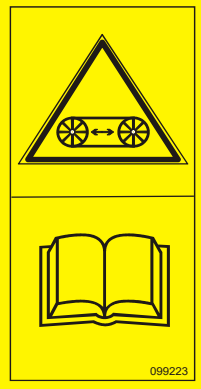

	099542	CAUTION! Trailer.
	086099	CAUTION! Keep away - hot parts!
	096321	Blade movement direction
	512235	Clean chain from sawdust every 50 hours of operation or once a week
	512157	Lubricate chain every 50 hours of operation or once a week

TABLE 1-1





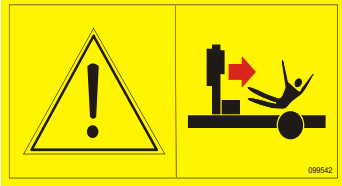

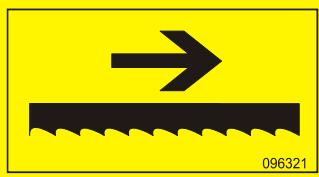
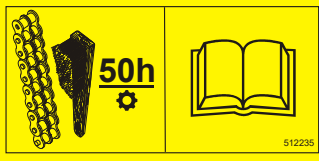
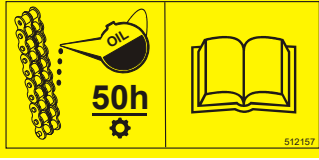

 <p>A blue circular icon with a white silhouette of a person wearing safety goggles. The icon is labeled 'S12004G' in the bottom right corner.</p>	<p>S12004G</p>	<p>CAUTION! Always wear safety goggles when operating the sawmill!</p>
 <p>A blue circular icon with a white silhouette of a person wearing protective ear muffs. The icon is labeled 'S12005G' in the bottom right corner.</p>	<p>S12005G</p>	<p>CAUTION! Always wear protective ear muffs when operating the sawmill!</p>
 <p>A blue circular icon with a white silhouette of a safety boot. The icon is labeled '501465' in the bottom right corner.</p>	<p>501465</p>	<p>CAUTION! Always wear safety boots when operating the sawmill</p>
 <p>A red circular icon with a black silhouette of a hand holding a spray nozzle, indicating a lubrication point. The icon is labeled '501467' in the bottom right corner.</p>	<p>501467</p>	<p>Lubrication Point</p>
 <p>A technical diagram showing two views of a saw blade being aligned on wheels. The top view shows the blade being moved up and down (indicated by vertical arrows) and rotated (indicated by a curved arrow). The bottom view shows the blade being moved down and up (indicated by vertical arrows) and rotated (indicated by a curved arrow). The diagram is labeled 'P11789b' in the bottom right corner.</p>	<p>P11789</p>	<p>Aligning the blade on the wheels</p>

TABLE 1-1

	<p>P85070</p>	<p>CE safety certification</p>
	<p>099401</p>	<p>Russian safety certification</p>
	<p>S20097B</p>	<p>3300 RPM - Motor rotation direction</p>
	<p>S20097E</p>	<p>2930 RPM - Motor rotation direction</p>

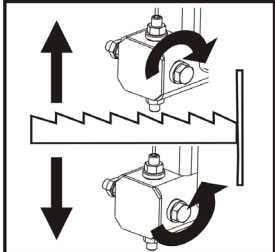
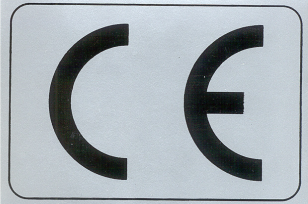
1.6 Belt Sizes

See Table 1-2. Belt sizes for the LT40 Series MAH are shown.

Description	Belt Size	Wood-Mizer Part #
Blade Pulley Belts	B57 ¹	P04185
Power Feed Drive Belt	AX13X1000	086532
Up/Down Drive Belt	AX23	015257
Board Return Belt	3L190	015477
Motor Drive Belt EA15 (50Hz)	2NX70	P04857-2
Motor Drive Belt EA20 & EA25 (50Hz)	3BX73	091548

TABLE 1-2

¹ To insure proper blade tracking, use Goodyear, Dayco Super II, or Brown-ing belts only.

1.7 Blade Sizes

See Table 1-3. Wood-Mizer TRU•SHARP™ offers three types of blades to provide efficient sawing for all models of sawmills. The engine/motor size of your sawmill and the type of wood you saw should determine which blade you choose for optimum performance.

	Softwood	Medium Hardwood	Frozen or Dense Hardwood
5-15HP Gas	.042 x 1 1/4" x 10°	.035 x 1 1/4" x 10°	.042 x 1 1/4" x 10°
7.4-11kW (10-15HP) Electric 16-24HP Gas 30HP Diesel	.045 x 1 1/2" x 10° or .045 x 1 1/4" x 10° ¹	.042 x 1 1/4" x 10°	.045 x 1 1/4" x 9° ²
15-18.5kW (20-25HP) Electric 40HP Diesel	.045 x 1 1/2" x 10° or .045 x 1 1/4" x 10° ³	.045 x 1 1/2" x 10° or .045 x 1 1/4" x 10° ³	.045 x 1 1/4" x 9° ²

TABLE 1-3

¹ Customer may choose preferred blade.

² TRU•SHARP™ 9° blades use a 9/29 profile (9° hook angle and 29° back angle) and are designed to cut frozen and/or extremely dense, hard-to-cut wood. Standard TRU•SHARP™ blades use a 10/30 profile.

See Table 1-4. Wood-Mizer TRU•SHARP™ offers three types of blades to provide efficient sawing for all models of sawmills. The engine/motor size of your sawmill and the type of wood you saw should determine which blade you choose for optimum performance.

	Softwood ¹	Medium Hardwood	Frozen Timber or Dense Hardwood
Benzynowy 5-15 KM	B275IH1030 B275IH741030	B375IH929	B375IH929 ²

TABLE 1-4

1

Safety & General Information**Cutting Capacity**

Elektryczny 7,4-11 kW (10-15KM) Benzynowy 16-25 KM Wysokoprężny 33 KM	B376IH1030 B376IH741030	B275IH1030 B275IH741030 B376IH1030 B376IH741030 ³	B375IH929 ²
15-18.5kW (20-25HP) Electric Diesel 42 KM	B376IH1030 B376IH741030	B275IH1030 B275IH741030 B376IH1030 B376IH741030 ³	B375IH929 ⁴

TABLE 1-4

¹ LT40 Sawmill is equipped with a blade with a length of 4.01 m.

² Piły TRU•SHARP™ "F" wykorzystują profil 9/29 (kął natarcia 9° i kął przyłożenia 29°) i zostały opracowane z przeznaczeniem do obróbki drewna zamrożonego i/lub wyjątkowo twardego, trudnego do cięcia. Standardowe piły TRU•SHARP™ wykorzystują profil 10/30.

³ Klient może wybrać piłę dowolnego typu.

⁴ TRU•SHARP™ "F" blades use a 9/29 profile (9° hook angle and 29° back angle) and are designed to cut frozen and/or extremely dense, hard-to-cut wood. Standard TRU•SHARP™ blades use a 10/30 profile.

LT40 Wide Sawmill is equipped with a blade with a length of 4.33 m.

See *The Blade Handbook* for blade hook angle, tooth height, and tooth set specifications.

1.8 Cutting Capacity

See Table 1-5. The log size capacities of the LT40 Wide.

	Max. cutting width	Max. cant width	Max. Diameter	Max. Length
LT40 S	84 cm (33")	62 cm (24")	100 cm (39")	4,8 m (15' 7")
LT40 M	84 cm (33")	62 cm (24")	100 cm (39")	6,1 m (20')
LT40 L	84 cm (33")	62 cm (24")	100 cm (39")	8,4 m (27')

TABLE 1-5

See Table 1-6. The LT70 Super sawmills can accept logs as listed below.

LT70 Super Sawmill	
Maximum Log Diameter	36,6" (93 cm)
Max. Length ¹	20'-2" (6.1 m)
Maximum Log Weight ²	4400 lbs. (1996 kg)

TABLE 1-6

¹ If your sawmill is equipped with a bed extension option, add the length of this extension to the sawmill length capacity (e.g. for BX12 add 12').

² Sawmills equipped with bed extensions can accept heavier logs. A load must be distributed uniformly on the frame and bed extension. Maximal weight for BX6 extension is 500kg, for BX12 – 1000kg, for BX24 – 2000kg. Failure to do so may result in machine damage or serious injuries.

1.9 Motor Specifications

See Table 1-7. The power options available for the LT40 Series AH. sawmills are listed below.

Model	Manufacturer	Rated output	Current at 380V, 50Hz	Rated speed	Weight
Sg132M-2P HPS Motor, Tamel	Tamel SA, Poland	11kW (15KM)	22,3 A	2950 RPM	69 Kg
3Sg 160M-2B-HM-T Motor, Tamel	Tamel SA, Poland	15kW (20KM)	28,1 A	2930 RPM	117 Kg
3Sg 160L-2-HM-T Motor, Tamel	Tamel SA, Poland	18.5kW (25KM)	33,8 A	2930 RPM	135 Kg

TABLE 1-7

Engine/Motor Type	Manufacturer	Model No.	Power	Other Specifications
28HP Gasoline	Kohler	CH745	28KM	3600 RPM, 725 cm ³
33HP Diesel	Kubota	V1505-EBB-EC-LT-STD.1	33KM	4 cylinders 1498 cm ³
42HP Turbo Diesel	Kubota	V1505-T-EBB-EC-LT-STD.1	42KM	4 cylinders, 1498 cm ³

TABLE 1-7

1 Safety & General Information

Motor Specifications

See Table 1-8. The other motors used in sawmills are listed below

Model	Manufacturer	Voltage	Rated output
Power Feed Motor controlled by ALTIVAR (Standard)	Besel, Poland	3x380V	0,75 kW, 1380 RPM
Power Feed Motor controlled by ALTIVAR (Super)	Besel, Poland	3x400V	1,1 kW, 1380 RPM
Up/Down Motor	Besel, Poland	3x380V	0,75 kW, 900 RPM
Up/Down Motor (2-Speed, Super only)	Besel, Poland	3x400V	0,55/0,9 kW, 950/1400 RPM
Hydraulic Pump Motor	Tamel, Poland	3x380V	3 kW, 1415 RPM
Hydraulic Pump Motor (Super only)	Tamel, Poland	3x400V	4 kW
Blade Guide Arm Motor	Motor Products Owosso, USA	12V	17W, 60 RPM

Engine/Motor Type	Manufacturer	Voltage	Power	WM Part #
Power Feed Motor	Leeson, USA	12V	1800 RPM-600W	024169
Up/Down Motor	Leeson, USA	12V	1800 RPM-600W	015174
Power Feed Motor (only Standard sawmills)	Motor Products Owosso, USA	12V	1000 RPM-430W	014359
Up/Down Motor (only Standard sawmills)	Motor Products Owosso, USA	12V	2200 RPM-390W	P04140
Blade Guide Arm Motor	Motor Products Owosso, USA	12V	60 RPM-17W	P09698-1
Hydraulic Pump Motor	Iskra	12V	2400 RPM-1320W	038683

TABLE 1-8

See Table 1-9. The noise level of the motors in Wood-Mizer sawmills.

Sawmill with electric motor	78 dB (A)
-----------------------------	-----------

TABLE 1-9

1.10 Overall Dimensions

See Table 1-10. The overall dimensions of the LT40 sawmills with M frame are listed below.

Sawmill Model	Length ¹	Width ²	Width (Operating Position with Loading Arms)	Height ³	Weight	Weight w/Trailer
LT70S	21' 11" (6.7 m)	6' 6" (2 m)	8' 2" (2.5 m)	7' 8" (2.4 m)	3291 lbs. (1481 kg)	3716 lbs. (1672 kg)
LT40M	24' 1" (7,5 m)	6' 6" (2 m)	8' 2" (2.5 m)	7' 8" (2.4 m)	3491 lbs. (1571 kg)	3916 lbs. (1762 kg)

TABLE 1-10

¹ Length from hitch to chain bracket.

² Width from fender to fender.

³ Height from ground to mast. Placing head in maximum position will add to total height.

See figure 1-1. The LT40 dimensions is shown below.

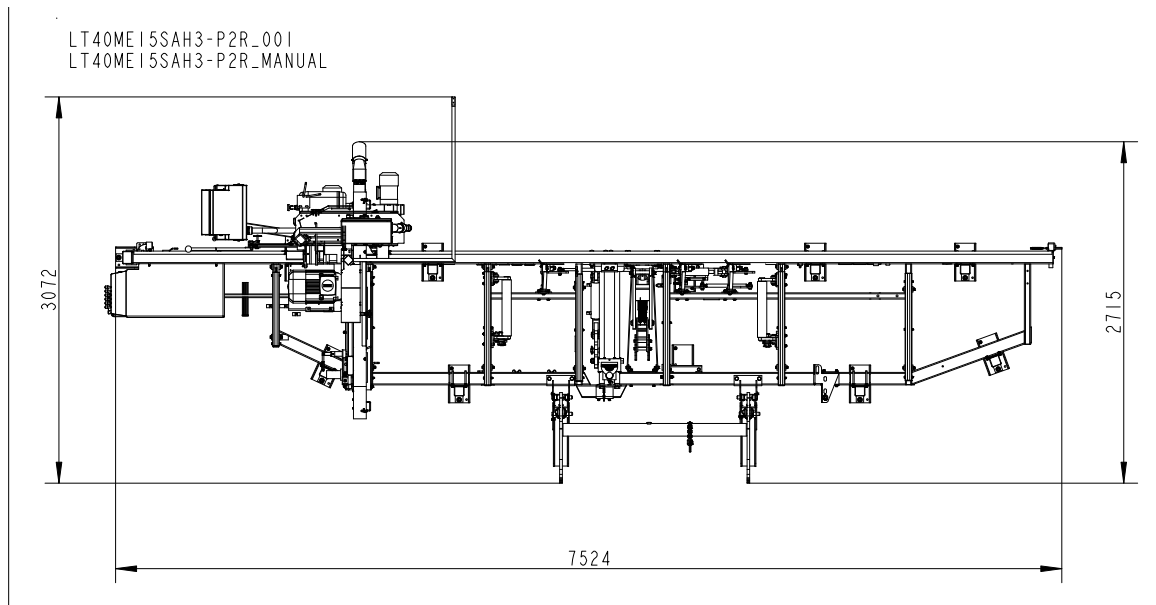

FIG. 1-1

1.11 Chains

See Table 1-11. The load capacity of the chains is listed below.

Load Capacity According to ISO Nr 08A-1

TABLE 1-11

Power Feed Chain	1780N
Up/Down Chain	1780N

TABLE 1-11

1.12 Hydraulic System

See Table 1-12. The specifications of the hydraulic system are shown below.

Hydraulic Pump	HYDROIRMA
Pressure Rating	15MPa

TABLE 1-12

1.13 Dust Extractor Specifications

See Table 1-13. Specifications of the dust extractors used on the resaw for each saw head are listed below.¹

Airflow	1200 m ³ /h 3937ft ³ /h
Inlet diameter	100 mm (5.9")
Motor power	1,5 kW
Number of sacks	1 pcs
Sack capacity	0,25 m ³ (8.8 ft) ³
Weight	110 kg (242.5 lb)
Pressure drop	1,5 kPa (0.22 psi) ¹
Recommended conveying air velocity in the duct	20 m/s 65.6 ft/s

TABLE 1-13

¹ The pressure drop between the inlet of the capture device and the connection to the CADES should be maximum 1,5 kPa (for the nominal air flow rate). If the pressure drop exceeds 1,5 kPa the machine might not be compatible with conventional CADES.



IMPORTANT! The dust extractor hoses must be grounded or made with materials not accumulating electrostatic charge.



CAUTION! Always turn on the dust extractor before starting the machine



IMPORTANT! The total value of hand-arm vibration the operator may be exposed to does not exceed 2.5 m/s². The highest root mean square value of weighted acceleration to which the whole operator's

1. External chip and dust extraction equipment with fixed installations are dealt with in EN 12779:2016-04

body is subjected does not exceed 0.5 m/s^2 .

1.14 Components

See figure 1-2. The major components of the Wood-Mizer LT40/70 are shown below.

LT40ME25SAHS7-P2R_001
LT40ME25SAHS7-P2R_MANUAL

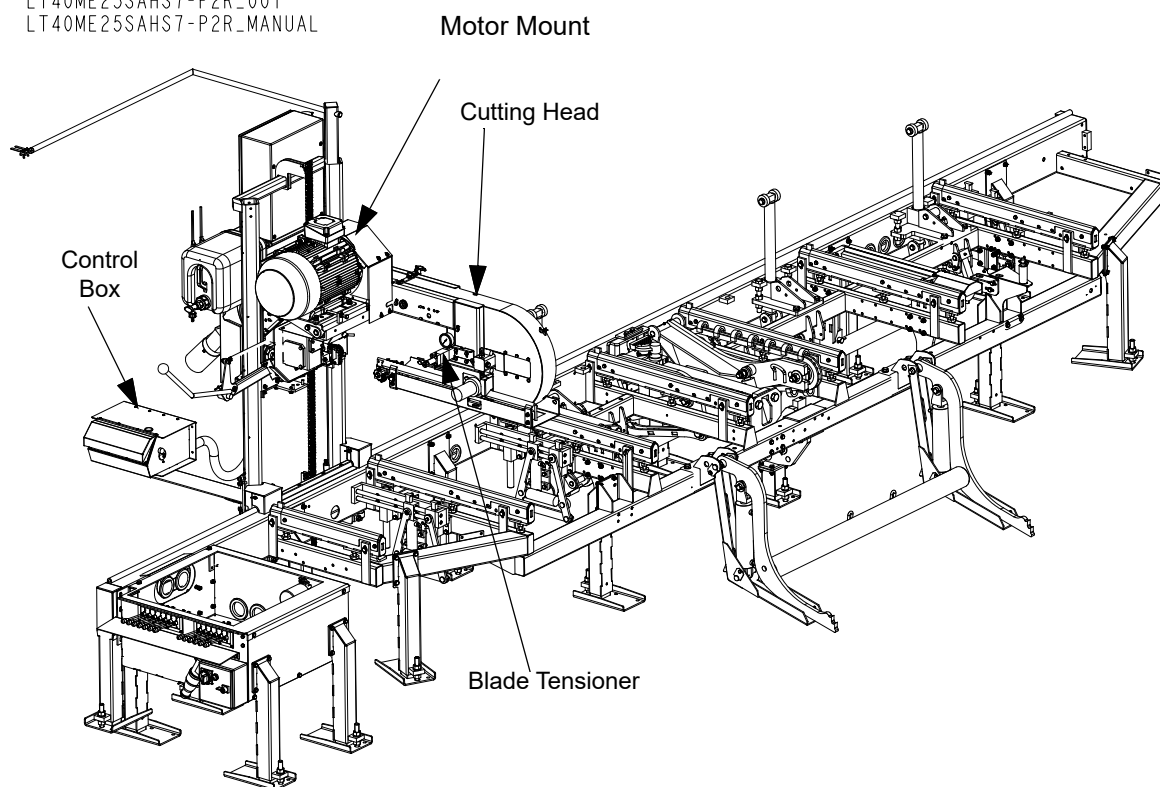

FIG. 1-2

1.15 LT40/70 S/M DH Hydraulic Schematic

See figure 1-3.

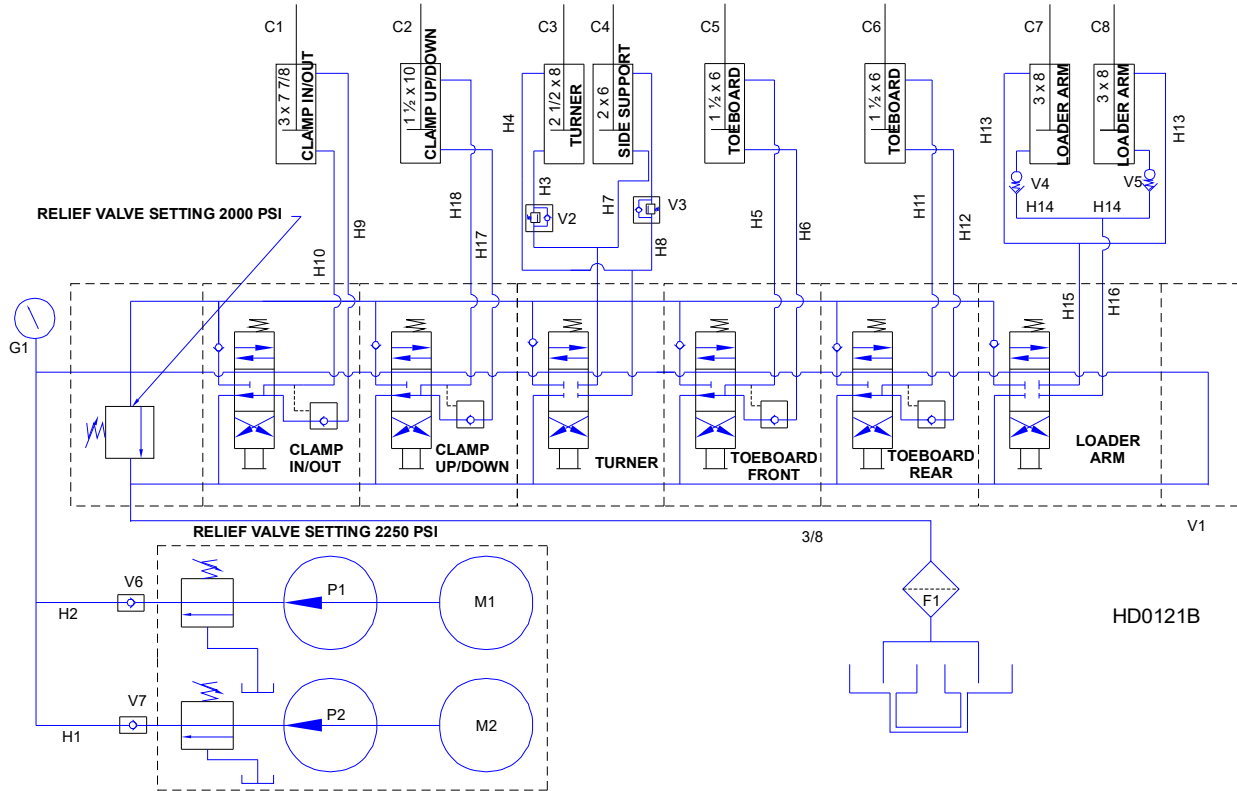

FIG. 1-3 HYDRAULIC SCHEMATIC (REV B1.00 - B2.01).

See figure 1-4.

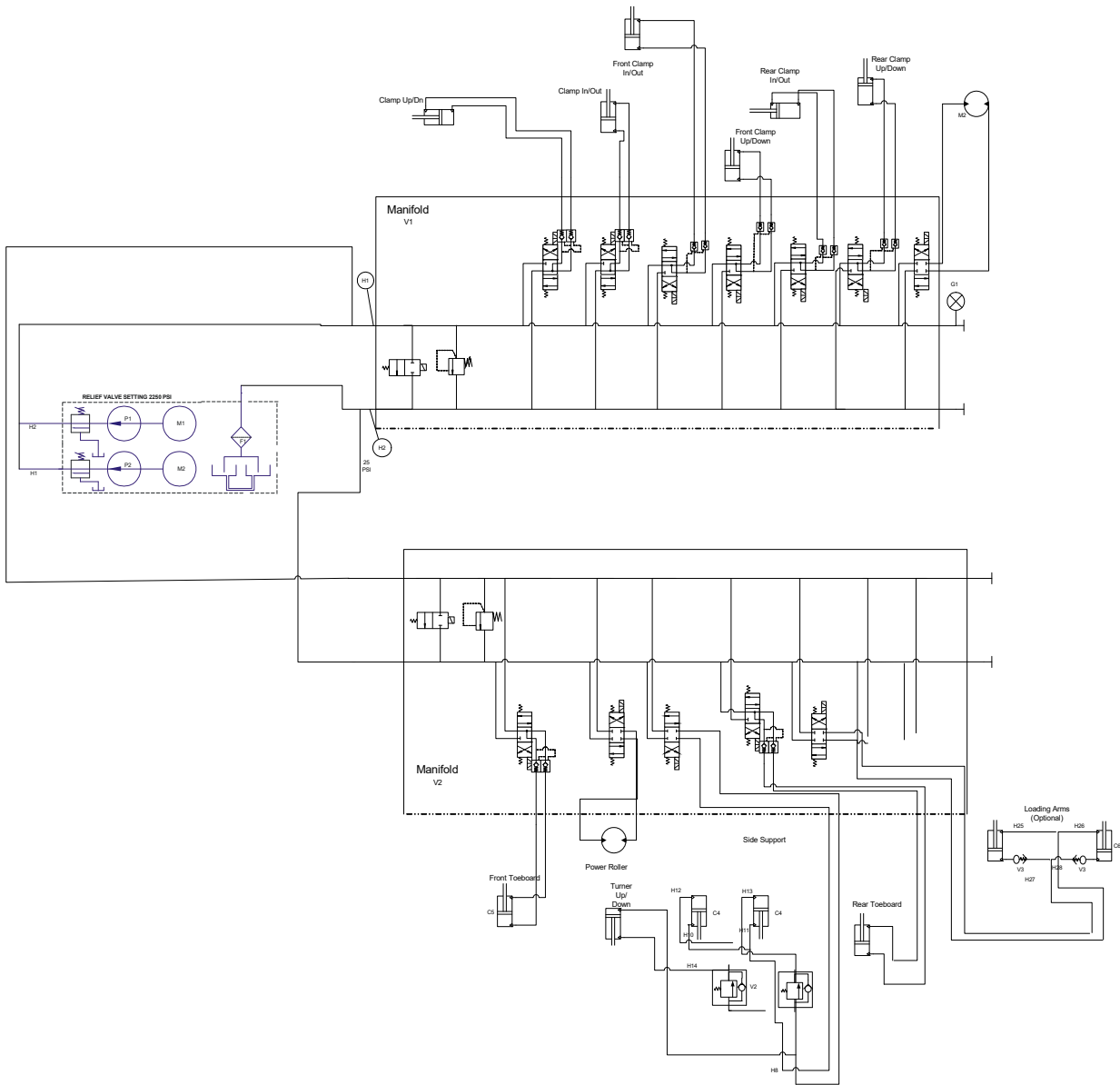

FIG. 1-4 HYDRAULIC SCHEMATIC.

See figure 1-5.

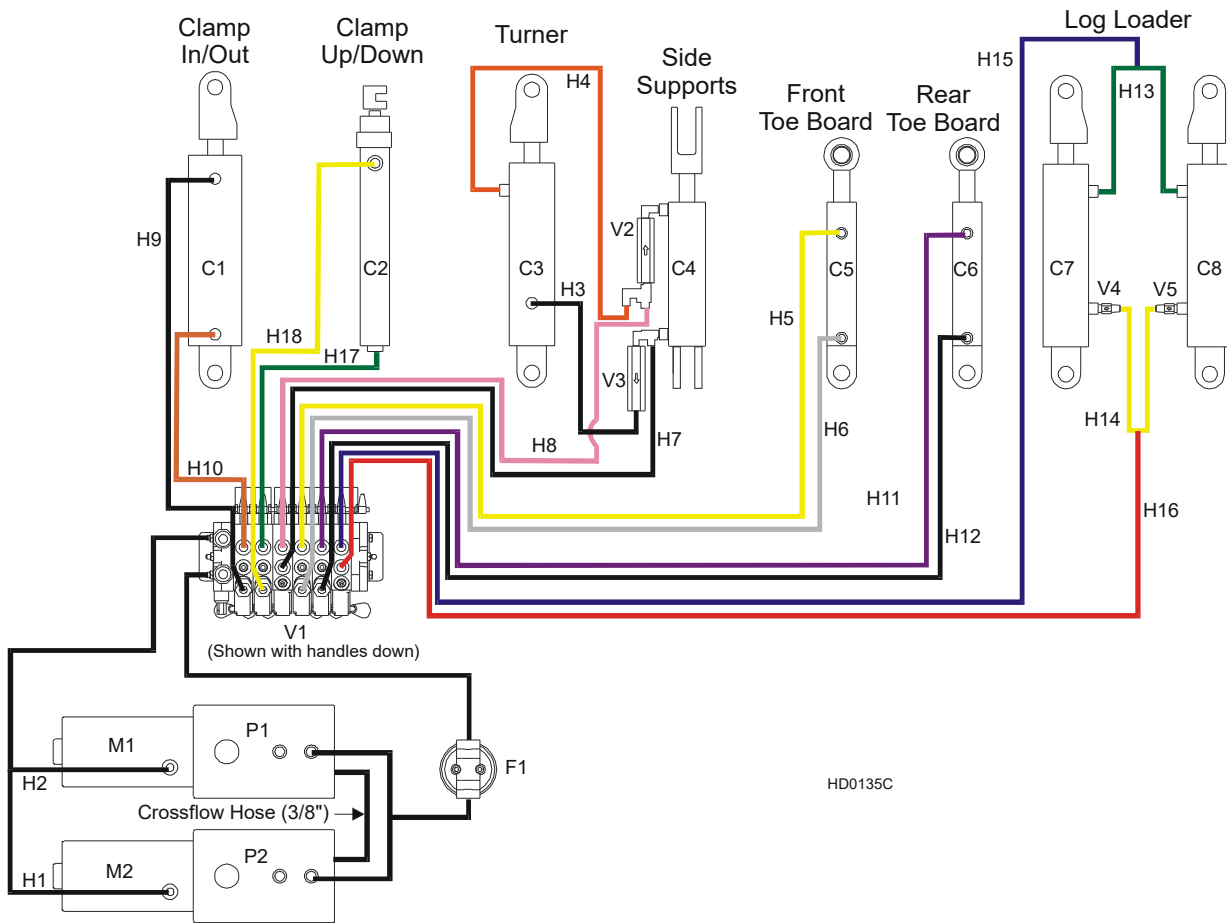

FIG. 1-5 HYDRAULIC SCHEMATIC.

1.16 LT40/70 S/M AH Hydraulic Schematic

See figure 1-6.

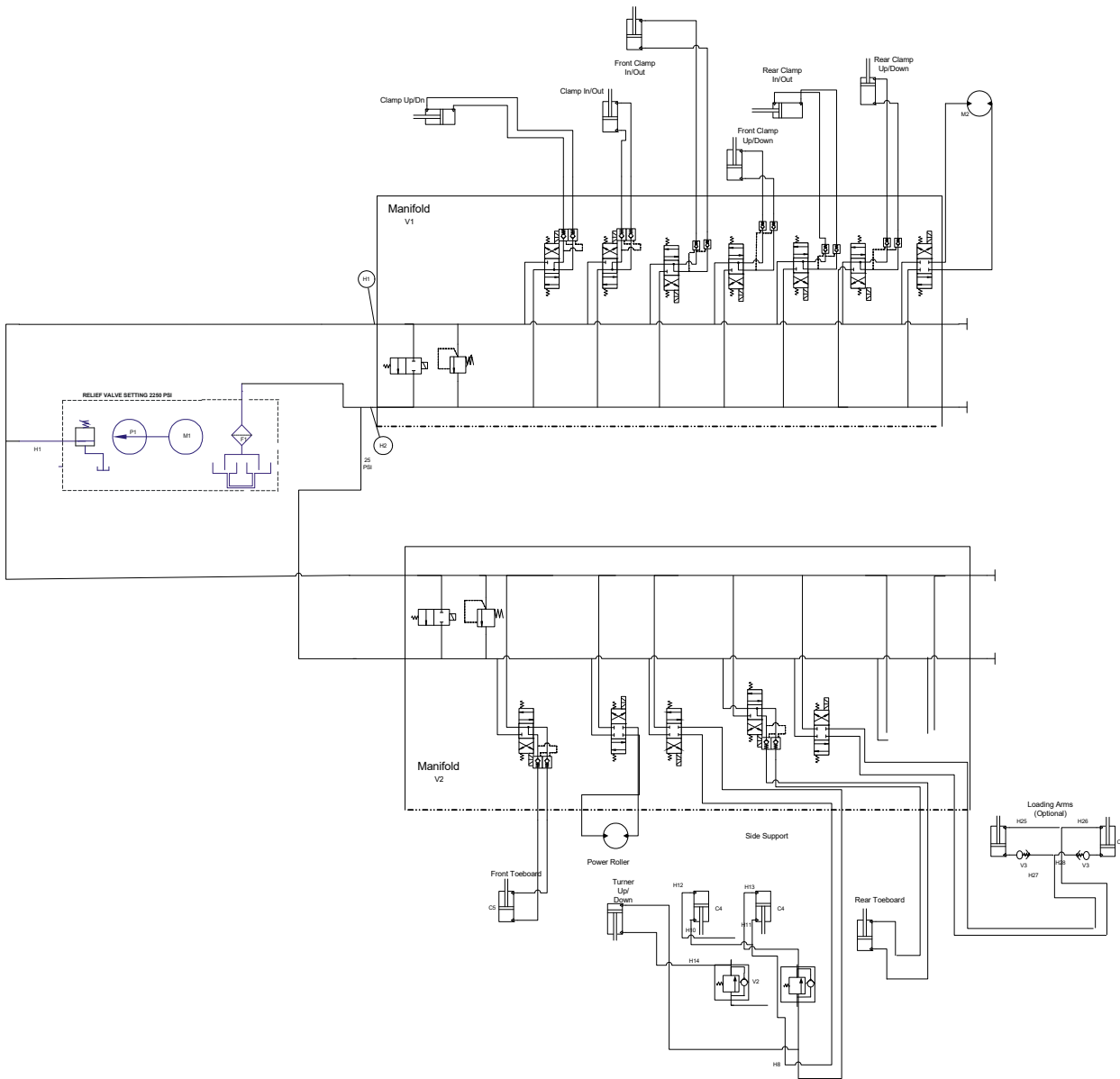

FIG. 1-6 HYDRAULIC SCHEMATIC.

1 Safety & General Information

LT40/70 S/M AH Hydraulic Components

See figure 1-7.

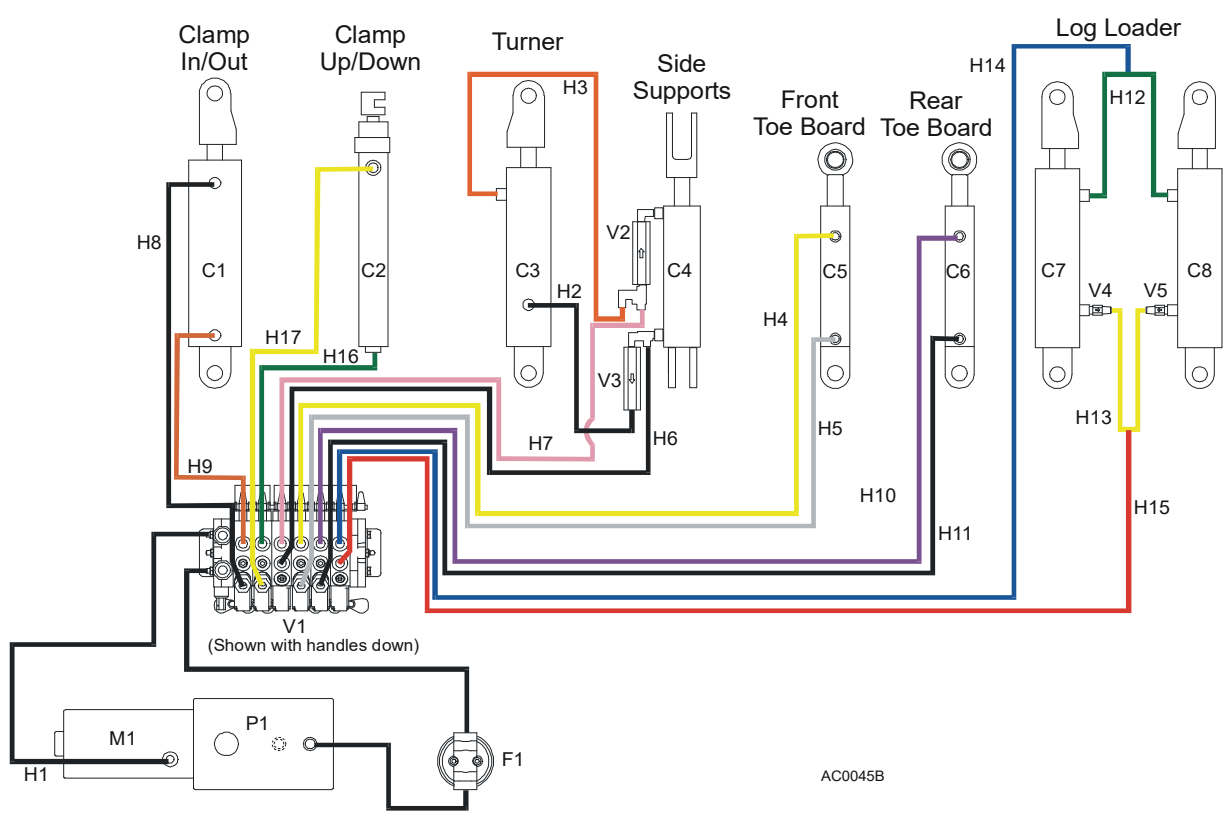

FIG. 1-7 HYDRAULIC SCHEMATIC.

1.17 LT40/70 S/M AH Hydraulic Components

See Table 1-14.

ID	Mfg. Part No.	Manufacturer	Wood-Mizer Part #	Description
C1	015090	J-D Hydraulic	017275	Hyd. Cylinder, 3" Bore x 7 7/8" Stroke
C2	PMC-19410	Prince Mfg.	015053	Hyd. Cylinder, 1 1/2" Bore x 10" Stroke
C3	P12846	J-D Hydraulic	P12846	Hyd. Cylinder, 2 1/2" Bore x 8" Stroke
C4	P12845	J-D Hydraulic	P12845	Hyd. Cylinder, 2" Bore X 6" Stroke
C5, C6	014482	J-D Hydraulic	014482	Hyd. Cylinder, 1 1/2" Bore x 6" Stroke
C7, C8	P12847	J-D Hydraulic	P12847	Hyd. Cylinder, 3" Bore X 8" Stroke
M1, P1	---	Hydromar, Szamotuly	086789	Hydraulic Unit (Container + Hydraulic Pump + Motor), 14.5 l/min.
V1	HDS11/6-6	Betro Inc.	015260	Valve, 6-Handle
V2, V3	49004-700	Vonberg	015484	Sequence Valve
V4, V5	28000-502-2.5	Vonberg	015750	Valve, Hydraulic Velocity Fuse
F1	S28	Hyd. Filter Supply	P20301	Filter, Hydraulic Fluid Cartridge
G1	CF-1P-210A	Pressure Devices Inc.	P10052	Gauge, 3000 PSI Hydraulic

TABLE 1-14

LT40/70 S/M DH Hydraulic components

See Table 1-15.

ID	Mfg. Part No.	Manufacturer	Wood-Mizer Part #	Description
C1	015090	J-D Hydraulic	015090	Hyd. Cylinder, 3" Bore X 7 7/8" Stroke
C2	PMC-19410	Prince Mfg.	015053	Hyd. Cylinder, 1 1/2" Bore x 10" Stroke
C3	P12846	J-D Hydraulic	P12846	Hyd. Cylinder, 2 1/2" Bore x 8" Stroke
C4	P12845	J-D Hydraulic	P12845	Hyd. Cylinder, 2" Bore X 6" Stroke
C5, C6	014482	J-D Hydraulic	014482	Hyd. Cylinder, 1 1/2" Bore x 6" Stroke
C7, C8	P12847	J-D Hydraulic	P12847	Hyd. Cylinder, 3" Bore X 8" Stroke
P1, P2	M300-0230	Monarch Hyd.	P12701	Hydraulic Pump, With Motor
V1	HDS10/6-6	Betro Inc.	015260	Valve, 6-Handle
V2, V3	49004-700	Vonberg	015484	Sequence Valve
V4, V5	28000-502-2.5	Vonberg	P11566	Valve, Hydraulic Velocity Fuse
M1, M2	08058	Monarch Hyd.	P09955	Motor, Hydraulic Pump
F1	S28	Hyd. Filter Supply	P20301	Filter, Hydraulic Fluid Cartridge
G1	CF-1P-210A	Pressure Devices Inc.	P10052	Gauge, 5000 PSI Hydraulic

TABLE 1-15

LT40/70 S/M DH Hydraulic Hoses

See Table 1-16.

ID	Color Code	LENGTH "A"	Application	Wood-Mizer Part No.
H1	Plain	18"	1/4" Hydraulic Pump To Valve	015704
H2	Plain	18"	1/4" Hydraulic Pump To Valve	015704
H3	Plain	27"	3/8" Log Turner Cylinder Base	014796
H4	Orange	0.69m (27")	3/8" Log Turner Cylinder Top	087775
H5	Yellow	3.27m (129")	1/4" Front Toe Board Top (LT40S)	087790
		3.83m (151")	1/4" Front Toe Board Top (LT40M)	087776
H6	Gray	3.27m (129")	1/4" Front Toe Board Base (LT40S)	087790
		3.83m (151")	1/4" Front Toe Board Base (LT40M)	087776
H7	Pink	4.2m (166")	3/8" Side Support Cylinder Base (LT40S)	087791
		4.77m (188")	3/8" Side Support Cylinder Base (LT40M)	087777

TABLE 1-16

1

Safety & General Information

LT40/70 S/M AH Hydraulic Components

H8	Plain	4.2m (166")	3/8" Side Support Cylinder Top ((LT40S))	087791
		4.77m (188")	3/8" Side Support Cylinder Top (LT40M)	087777
H9	White	3.68m (145")	3/8" Clamp Up (LT40S)	087792
		4m (157")	3/8" Clamp Up (LT40M)	087778
H10	Dark Orange	3.28m (129")	3/8" Clamp Cylinder Base (LT40S)	087793
		3.8m (151")	3/8" Clamp Cylinder Base (LT40M)	087779
H11	Purple	5.2m (204")	1/4" Rear Toe Board Top (LT40S)	087794
		5.74m (226")	1/4" Rear Toe Board Top (LT40M)	087780
H12	Black	5.2m (204")	1/4" Rear Toe Board Base (LT40S)	087794
		5.74m (226")	1/4" Rear Toe Board Base (LT40M)	087780
H13	Green	1.58m (62")	3/8" Loading Arm Branch Top	014797
H14	Yellow	1.6m (63")	3/8" Loading Arm Branch Base	014798
H14	Yellow	1.8m (71")	3/8" Loading Arm Branch Base	093329
H15	Blue	4.34m (171")	3/8" Loading Arm Cylinder Top (LT40S)	087795
		4.9m (193")	3/8" Loading Arm Cylinder Top (LT40M)	087781
H16	Red	4.34m (171")	3/8" Loading Arm Cylinder Bottom (LT40S)	087795
		4.9m (193")	3/8" Loading Arm Cylinder Bottom (LT40M)	087781
H17	Green	4.57m (180")	1/4" Clamp Up (LT40S)	087796
		5.1m (202")	1/4" Clamp Up (LT40M)	087789
H18	Yellow	4.57m (180")	1/4" Clamp Down (LT40S)	087796
		5.1m (202")	1/4" Clamp Down (LT40M)	087789

TABLE 1-16

[See Section 9.1](#) LT40 Super Parts List.

SECTION 2 SETUP & OPERATION

2.1 Sawmill Setup



IMPORTANT! Before starting to use the sawmill you have to meet the following conditions:

- Set up the sawmill on firm and level ground.
- The sawmill can be operated with the sawdust collection system only.
- The sawmill can be operated under roof only.
- The sawmill can be operated in temperature range from -15° C to 40° C only.
- Illuminance at operator's position must be 300lx.
- The sawmill operator's position is shown below.

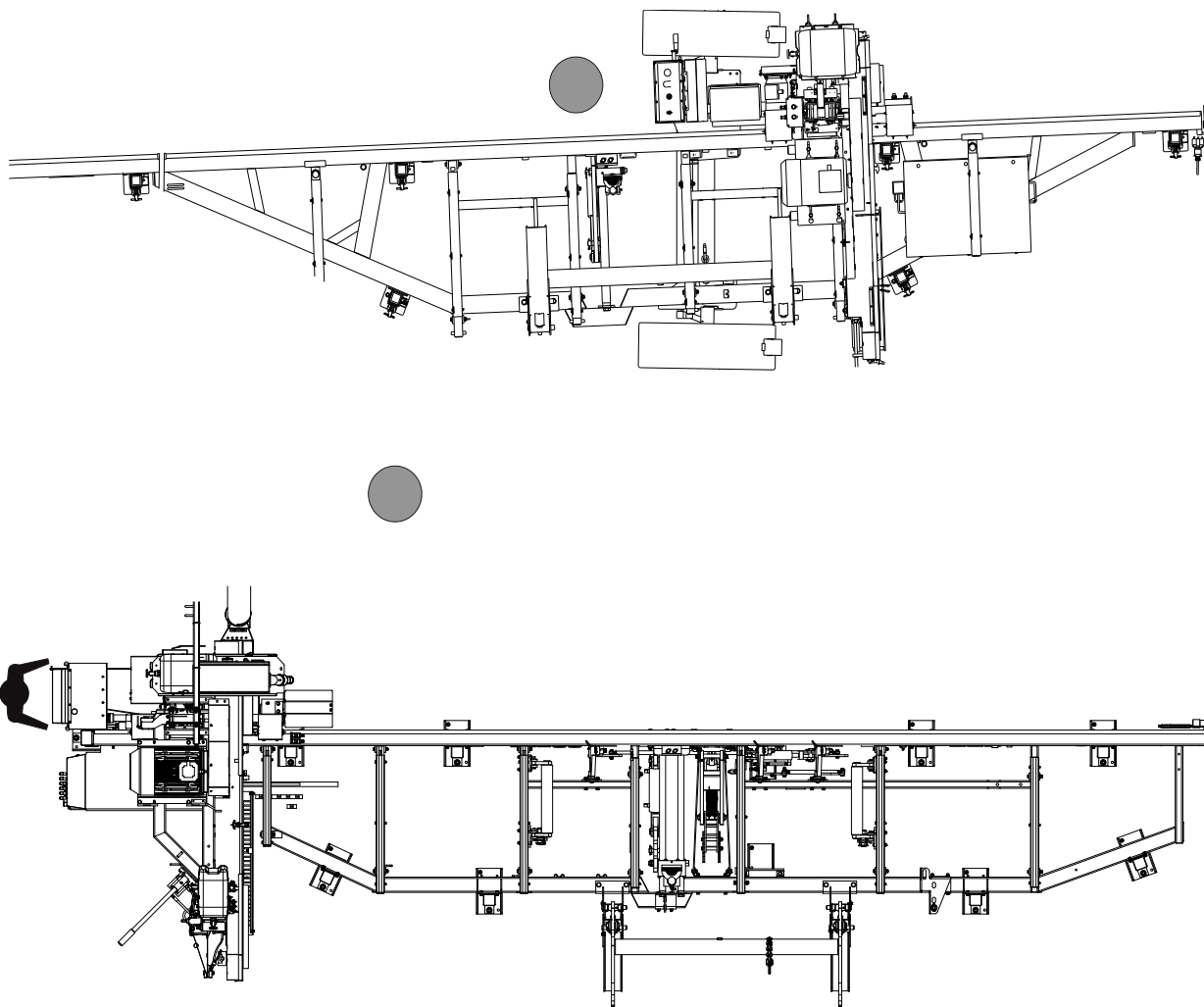

- Have a qualified electrician install the power supply (according to EN 60204 Standard). The power supply must meet the specifications given in the table below.

See Table 2-1.

3-Phase Volts	Fuse disconnect	Suggested Wire Size
400 VAC	40 A	6 mm ² up to 15 m long

TABLE 2-1



IMPORTANT! When starting the machine for the first time, check that main motor rotation direction is as indicated by the arrow located on the motor body (fan guard). If the rotation direction is incorrect, invert the phases in the phase inverter in the power socket (electric box). Setting the phases in the phase inverter correctly will ensure correct rotation directions of all sawmill motors.

2.2 Stationary Sawmill Setup

Set up the mill on firm footing and level by eye. Fasten the mill to the floor to prevent any creep after prolonged use. Overall Dimensions- See Tabela 1-8 na stronie 14.

See figure 2-1.

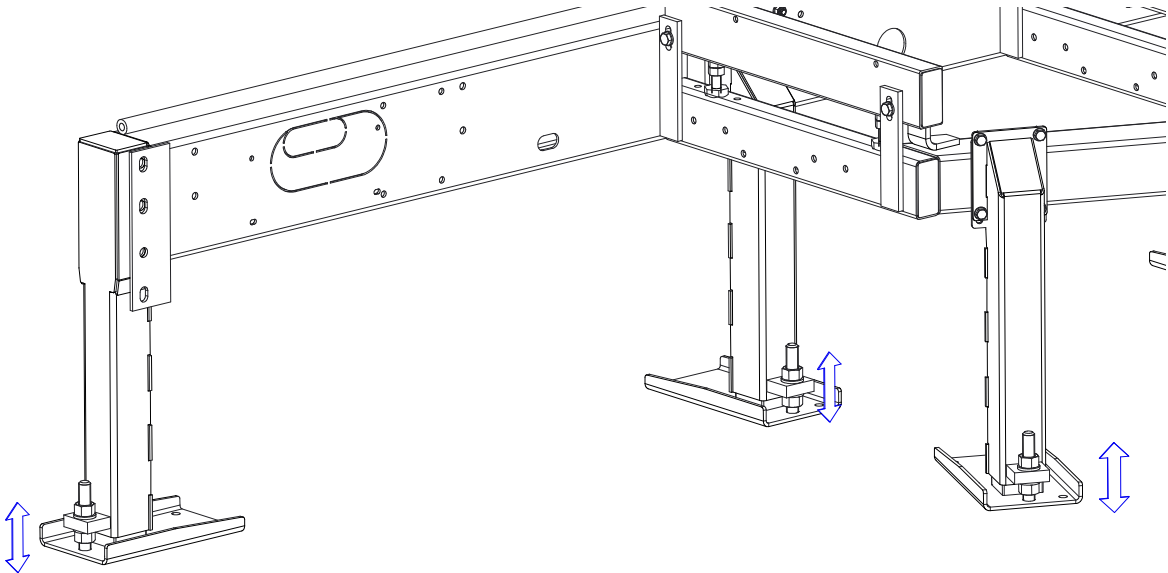

FIG. 2-1

See figure 2-2. LT M Super

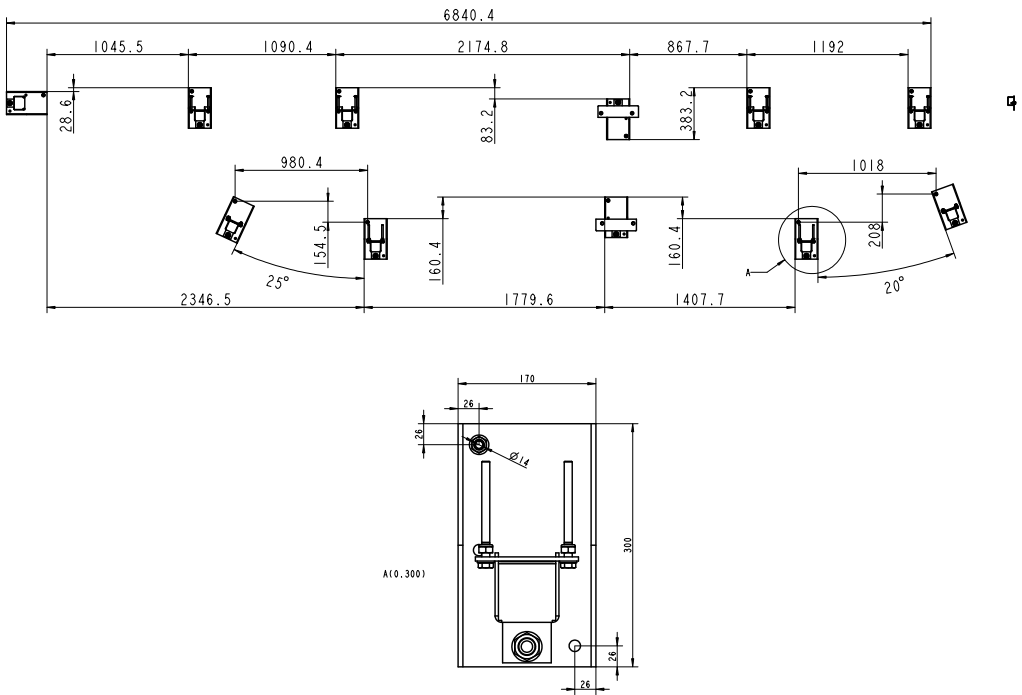

FIG. 2-2

See figure 2-3. LT S Super

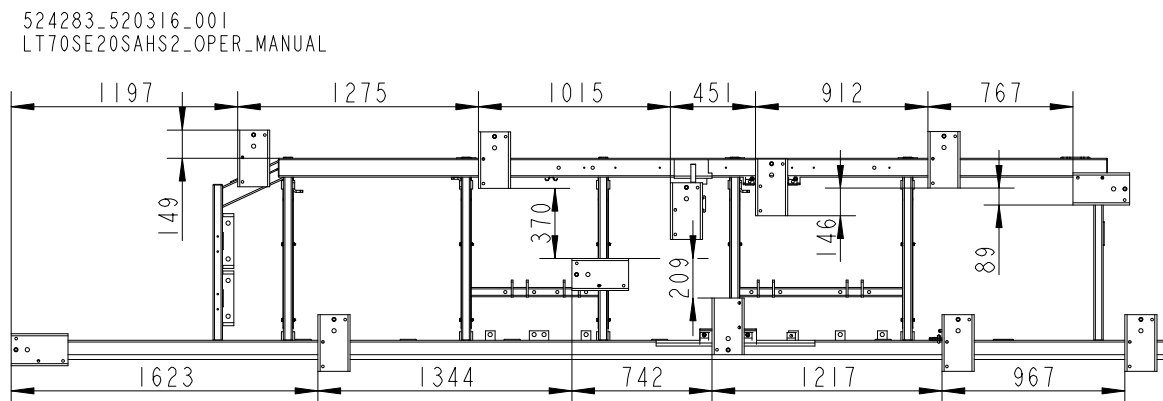

FIG. 2-3

1. Unlock hydraulic control box by pulling out locking pin from the control box blockade. Remove the control box blockade from the saw head track rails.
2. Unhook the carriage safety chain, located at the bottom of the vertical mast, near battery box.
3. Turn the key switch on the control panel to the accessory position ACC (#3), to enable the battery-operated accessories. Use the up/down switch on the control panel to raise the cutting head from the carriage rest pin. Remove the locking pin and swing the rest pin down below bed level.
4. Turn the key switch on the control panel to the accessory position. Use the up/down switch on the control panel to raise the cutting head from the carriage rest pin. Remove the locking pin and swing the rest pin down below bed level.
5. Use the carriage fwd/rev switch (left side of control box) to move the cutting head toward the front end of the mill. The hydraulic control levers become operational when the contacts at the bottom of the carriage touch the power strip on the frame tube. The hydraulic control levers will only work when the cutting head is close enough to the front end of the mill to touch the power strip.
6. Raise the side supports that will prevent a log from falling off the side of the mill when loaded.



See figure 2-4.

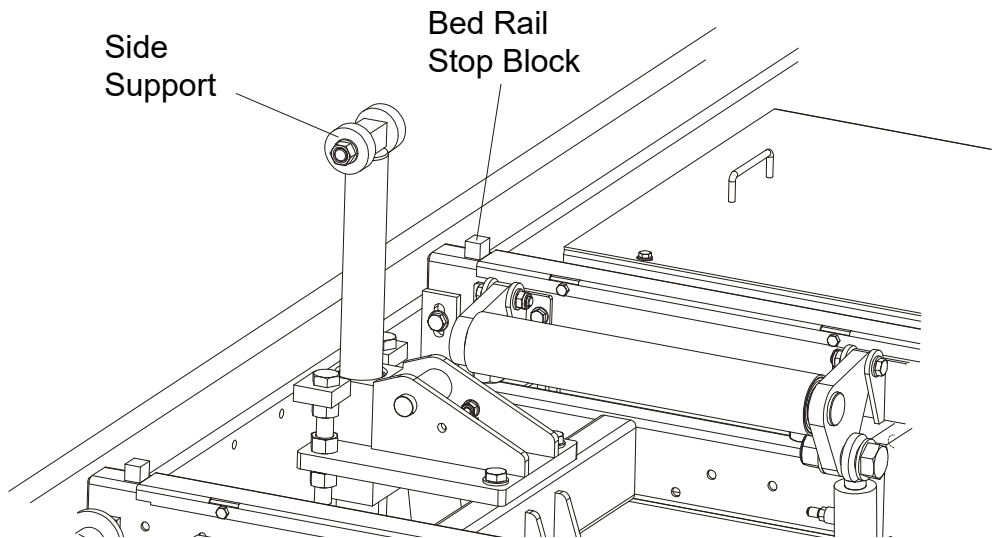

FIG. 2-4

2.3 Sawmills with cable guide

See figure 2-5. The figure below shows setup of the sawmill, the control box and the guiding rail columns.

Secure the columns to the ground using 16mm anchored bolts.

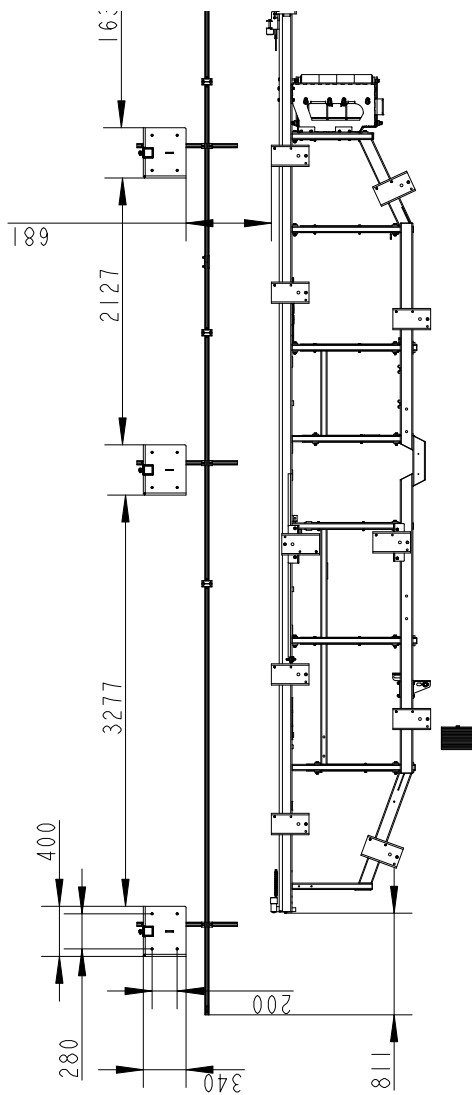

FIG. 2-5 LT40MRC

See figure 2-6. The electrical wires should be installed on the guiding rail as shown below.



FIG. 2-6

See figure 2-7. Install the rail bracket arm as shown below.

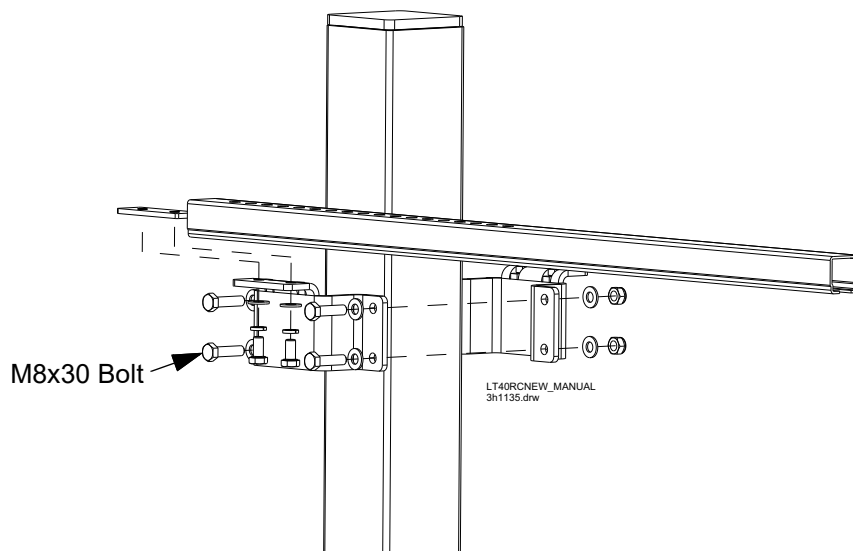

FIG. 2-7

See figure 2-8. Install the guiding rail.

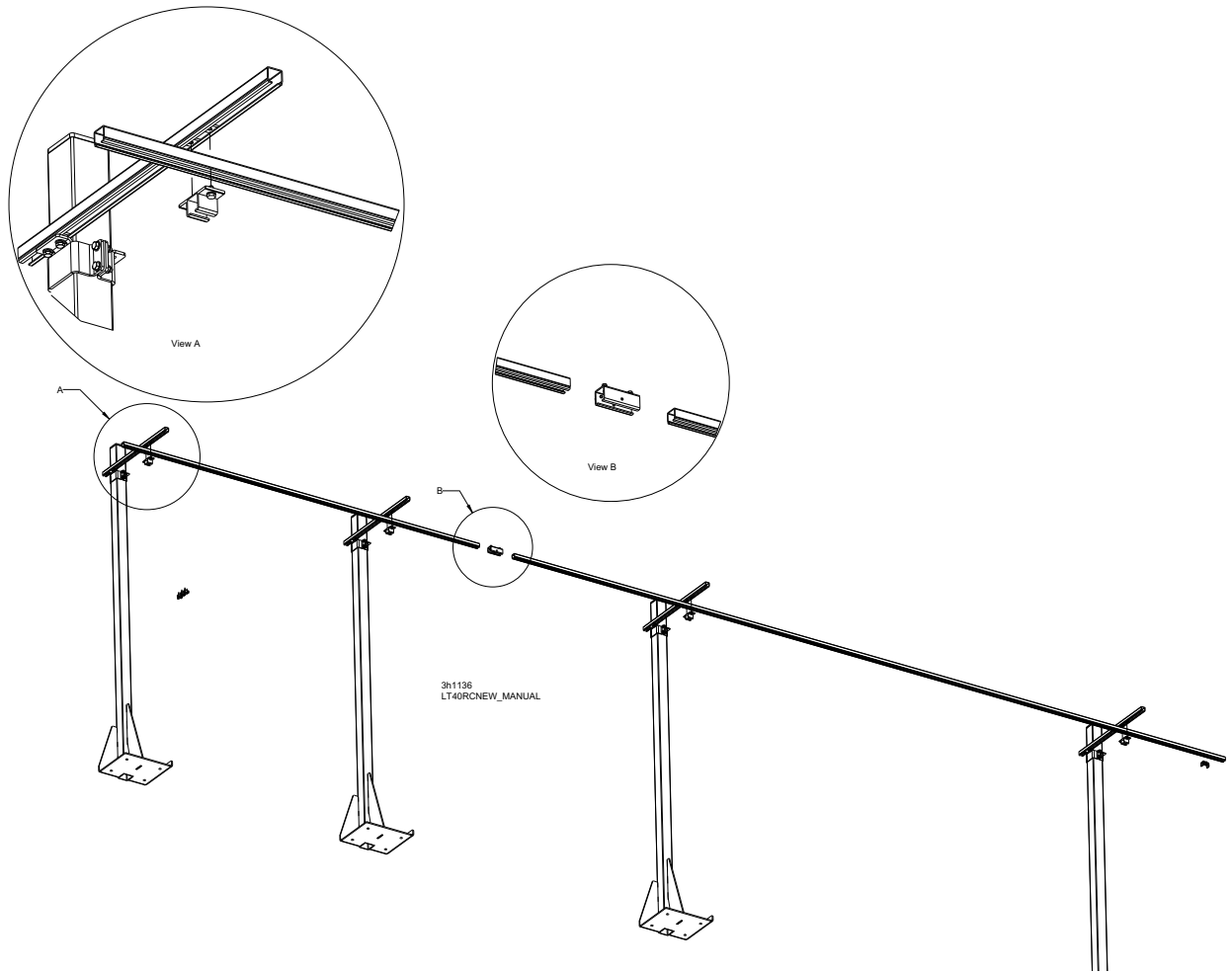

FIG. 2-8

See figure 2-9.

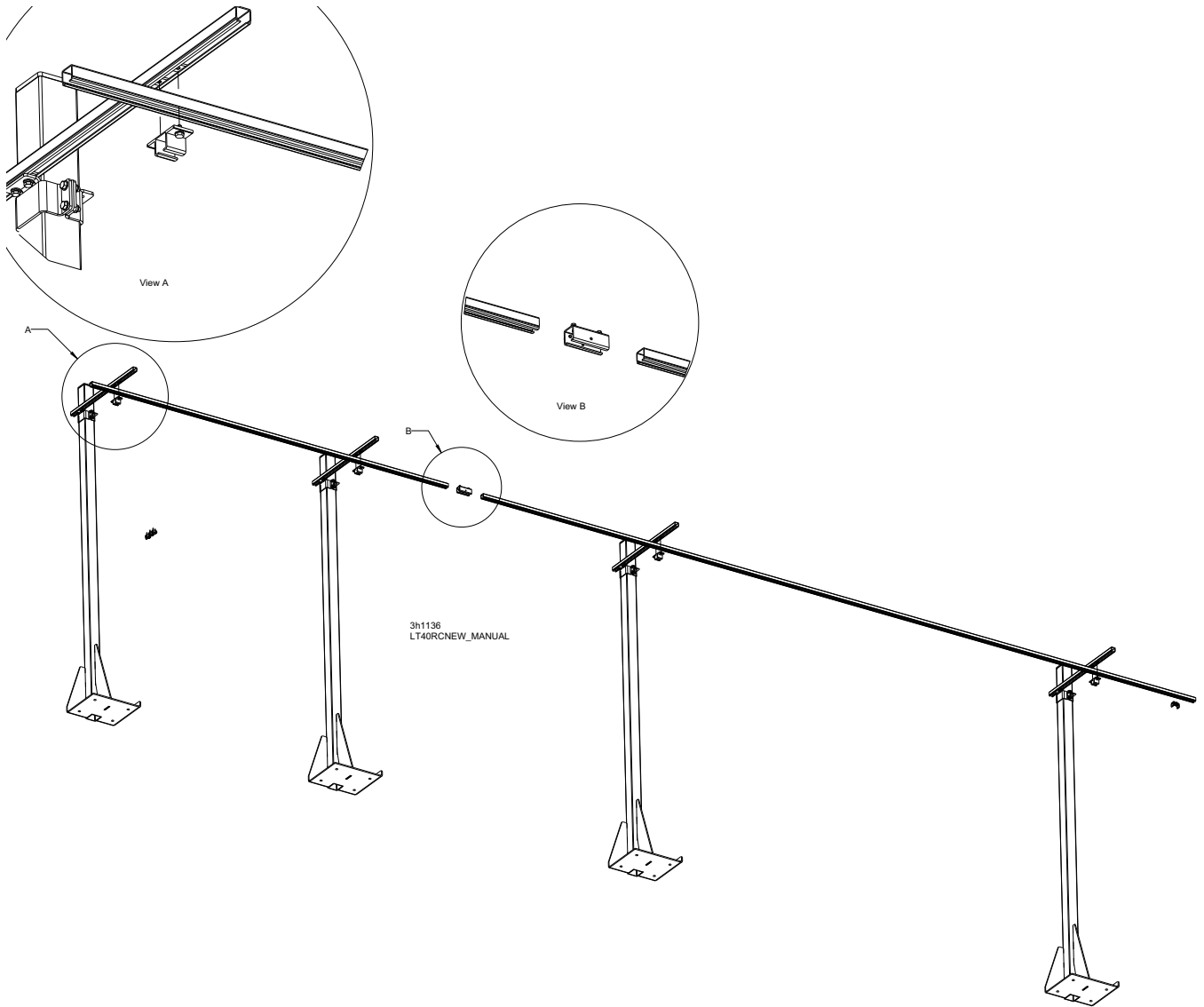

FIG. 2-9

See figure 2-10. The figure below shows how the cable hanger should be set.

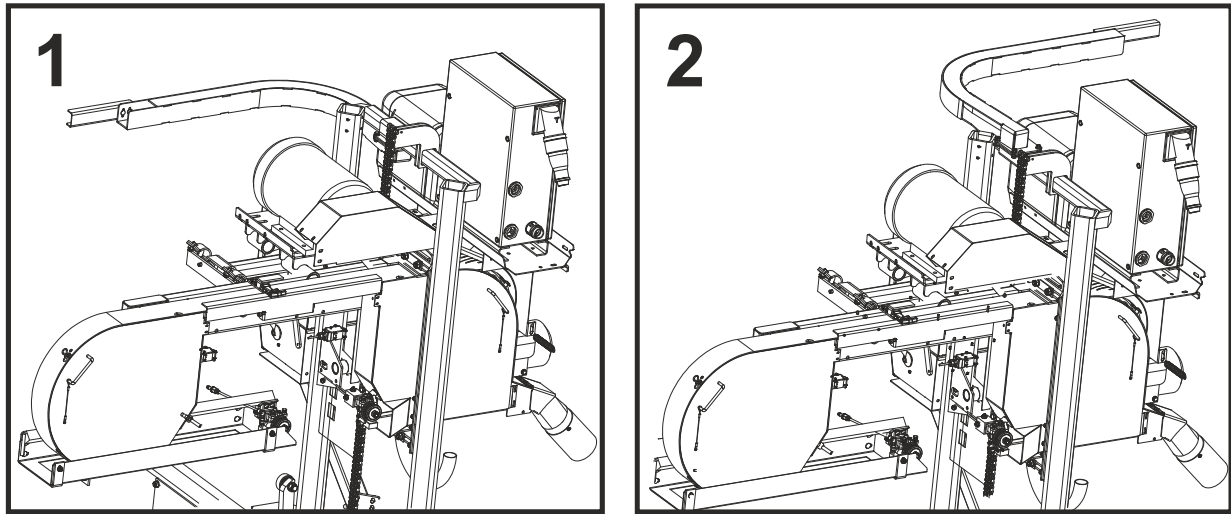

FIG. 2-10

Unbolt the four bolts, rotate the hanger 90 degrees to the right and tighten the bolts.

2.4 Portable Sawmill Setup



WARNING! Do not set up the mill on ground with more than a 10 degree incline. If setup on an incline is necessary, put blocks under one side of the mill or dig out areas for outrigger legs to keep mill level. Setting up the mill on an incline could cause it to tip over, resulting in serious personal injury.

WARNING! Chock the trailer wheels to prevent movement before unhitching it from the towing vehicle. Failure to do so will result in serious injury or death.

WARNING! Always make sure the trailer is supporting the sawmill frame when operating a sawmill with adjustable outriggers. Failure to do so will result in serious injury or death. The adjustable outriggers are intended to support the saw frame with assistance from the trailer.

1. Unhitch the mill from the vehicle.
2. Lower and set the front outriggers. To lower the leg, first place a 19 socket wrench on the outrigger adjustment bolt and turn the bolt until the outrigger movable part reaches its highest position. Next pull the locking pin out of the outrigger hole. When the outrigger contacts the ground, release the pin. Then place a 19 socket wrench on the outrigger adjustment bolt and turn the bolt until the locking pin enters the nearest outrigger hole.



WARNING! Put front outrigger down before moving cutting head from the rest position. Failure to do so may result in serious injury.

See figure 2-11.

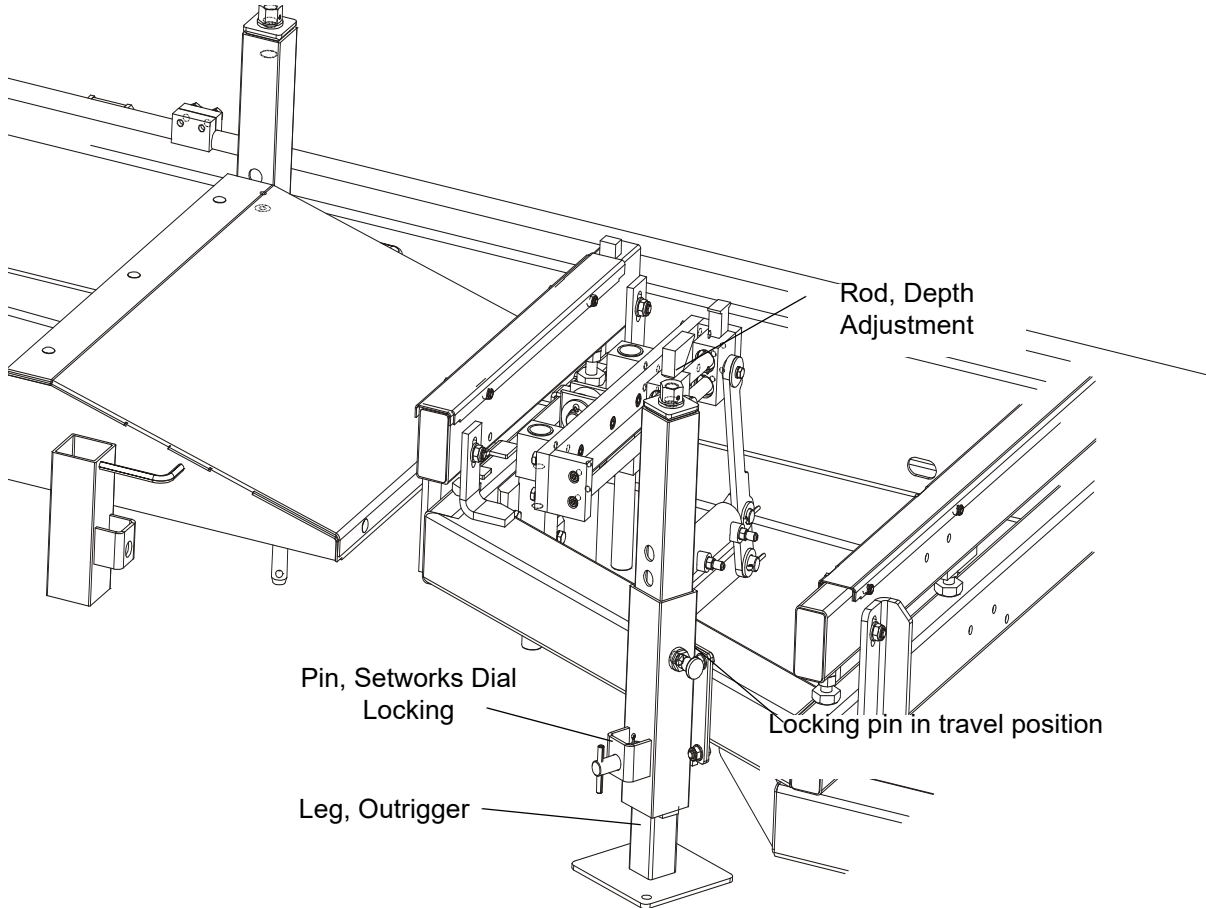

FIG. 2-11. OUTRIGGER ADJUSTMENT

3. Unhook the carriage safety chain, located at the bottom of the vertical mast.
4. Turn the key switch on the control panel to the ACC (#3)(#1) position, to enable the battery-operated accessories. Use the up/down switch on the control panel to raise the cutting head from the carriage rest pin. Remove the locking pin and swing the rest pin down below bed level.
5. Remove the fenders by lifting them out of the slots.



CAUTION! To prevent fender damage, remove fenders before operating sawmill or loading logs.

6. Use the carriage fwd/rev switch (left side of control box) to move the cutting head toward the front end of the mill. Lower and set the remaining rear outriggers.



7. Level the sawmill by adjusting the outriggers to raise or lower each end of the sawmill. Adjust all outriggers evenly to avoid twisting the mill frame by jacking one outrigger higher than the others.

2 Setup & Operation

Portable Sawmill Setup

Raise the side supports to prevent the log from falling off the side of the mill when loaded.

See figure 2-12.

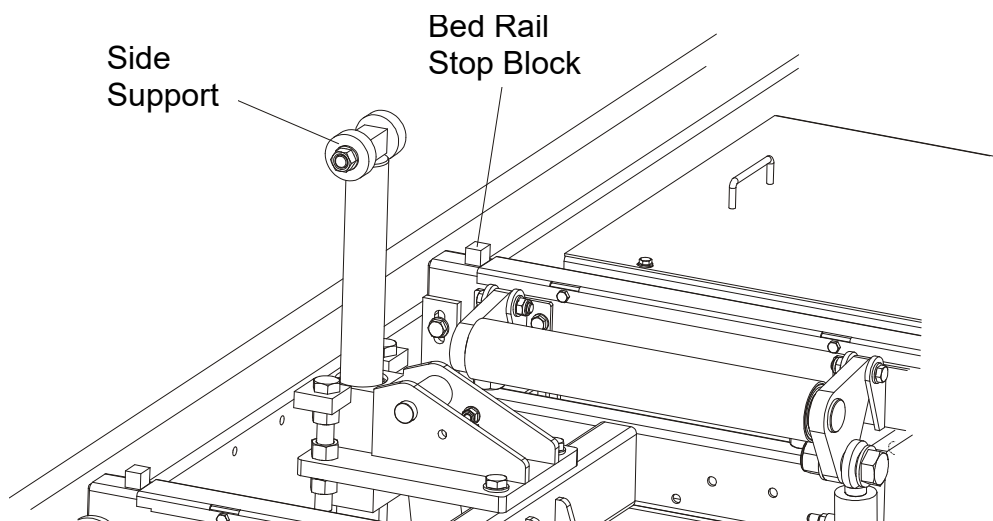

FIG. 2-12

2.5 Middle Track Cover

Before operating the sawmill do as follows:

1. Clean the upper and lower rails to remove any sawdust and rust preventives.
2. Unbolt and remove the middle track cover from its storage position.
3. Soak the felt wiper with Dexron III transmission fluid, 10W30 motor oil or 3-in-1 turbine oil.
4. Install the middle track cover so it fits against the rail and secure with two thumb screws.

See figure 2-13.

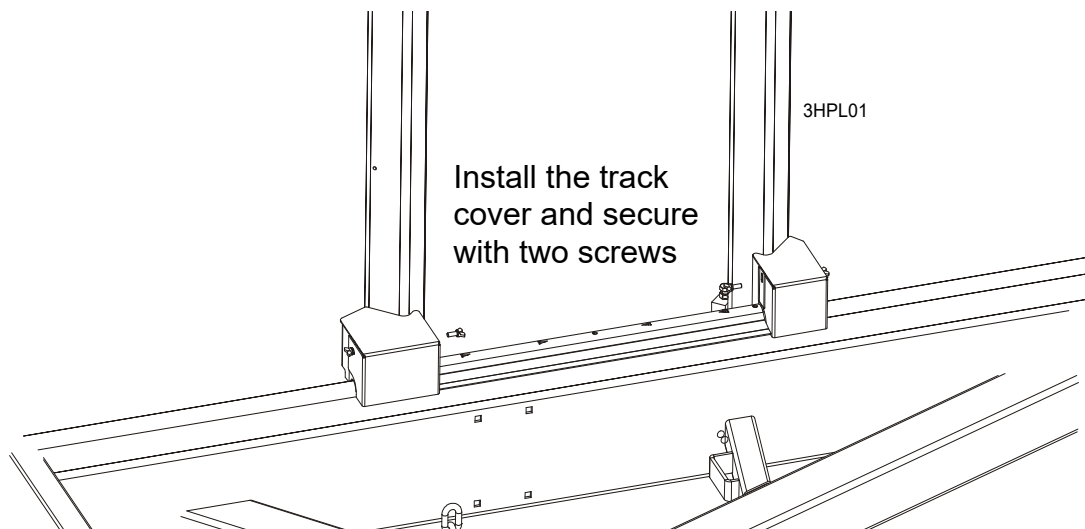

FIG. 2-13

CAUTION! Install the track cover so that it lightly touches the track rail. If the wiper presses too firmly against the rail, it can cause the power feed to bind.

2.6 Replacing The Blade



DANGER! Always disengage the blade and shut off the sawmill engine before changing the blade. Failure to do so will result in serious injury.



WARNING! Always wear gloves and eye protection when handling bandsaw blades. Changing blades is safest when done by one person! Keep all other persons away from area when coiling, carrying or changing a blade. Failure to do so may result in serious injury.

Remove the two main blade housing covers that cover the blade wheels. Lower the hinged middle blade housing cover. Turn the blade tension handle to release the blade tension until the wheel is pulled in and the blade is lying loose in the blade housing. Lift the blade out of the blade housing.

When installing a blade, make sure the teeth are pointing the correct direction. The teeth should be pointing toward the operator side of the mill when you are looking at the blade below the blade guides. Install the blade so it is lying around the wheels.

Position 1 1/4" wide blades on the wheels so the gullet is 1/8" (3.0 mm) out from the edge of the wheel. Position 1 1/2" wide blades on the wheels so the gullet is 3/16" (4.5 mm) out from the edge of the wheel.

Close the middle blade housing cover.

Next, turn the tension handle until the blade is tensioned correctly.

2.7 Tensioning The Blade

See figure 2-14. Tension the blade by turning the hydraulic tensioning handle clockwise until the tension gauge indicates the recommended tension.

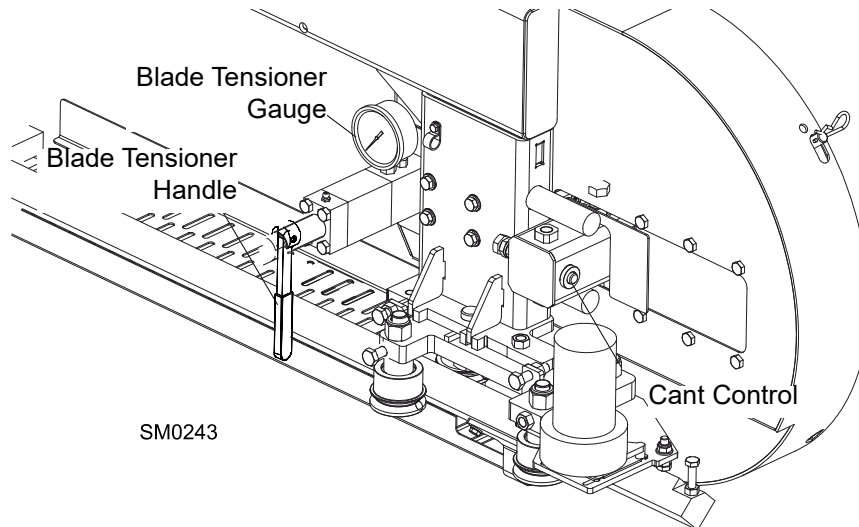

FIG. 2-14

See Table 2-2. The recommended tension for different blades is shown below.

Blade Type	Acceptable Range	Ideal Tension
B375IH929	12,4 - 14,5 MPa (1800 - 2100 psi)	13,8 MPa (2000 psi)
B275IH1030	14,5 - 16,5 MPa (2100 - 2400 psi)	15,9 MPa (2300 psi)
B2735	16,5 - 17,9 MPa (2400-2600 psi)	17,0 MPa (2466 psi)
B275IH741030	14,5 - 16,5 MPa (2100 - 2400 psi)	15,9 MPa (2300 psi)

TABLE 2-2

The tension gauge should be checked occasionally when adjusting the cant control or while cutting. Ambient temperature changes will cause tension to change. Adjust the tension handle as necessary to maintain the recommended tension level.

CAUTION! Changes in temperature could cause increased pressure in the blade tensioner and loss of fluid from the gauge. Release the blade tension when the mill is not in use to avoid damage to the tensioner.

2.8 Tracking The Blade

1. Make sure the middle blade housing cover is closed and all persons are clear of the open side of the saw head.
2. Start the motor by pushing the START button located on the control box.



WARNING! Do not spin the blade wheels by hand. Spinning the blade wheels by hand may result in serious injury.

3. Push the STOP button to stop the blade. Remove the key and check the position of the blade on the blade wheels.

See figure 2-15. Position 1 1/4" wide blades so the gullet is 3.0 mm (0.12") out from the edge of the blade wheel (± 1.0 mm [0.04"]). Position 1 1/2" blades so the gullet is 4.5 mm (0.18") out from the edge of the blade wheel (± 1.0 mm [0.04"]).

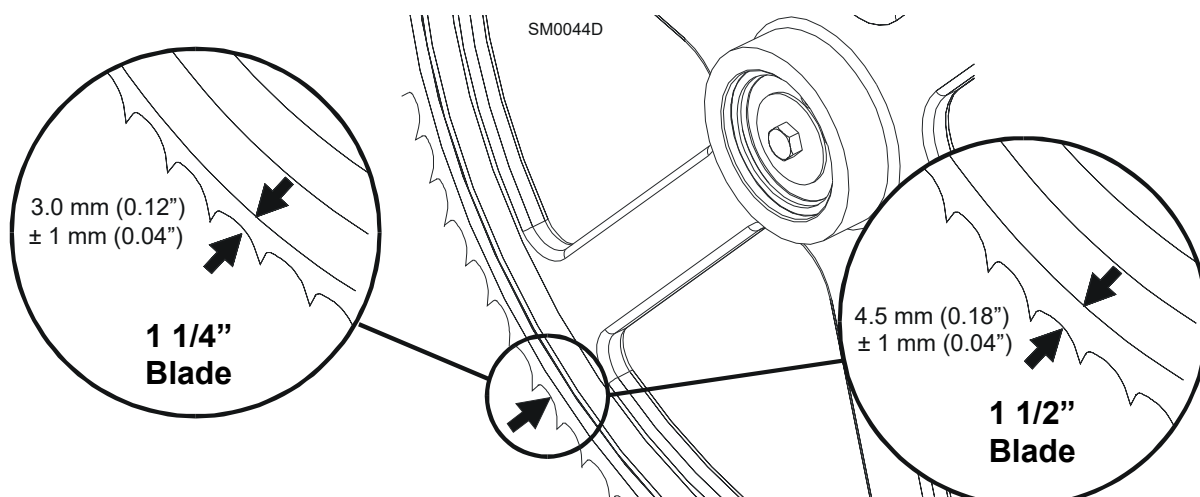

FIG. 2-15

4. To adjust where the blade travels on the blade wheels, use the cant control shown in Figure 2-14.
If the blade is too far out, back the blade onto the wheel by turning the cant control counterclockwise. If the blade is too far in, turn the cant control clockwise until the gullet of the blade is the correct distance from the front edge of the wheel.
5. Retension the blade to the recommended tension to compensate for any adjustments you have made in the cant control.
6. Replace the blade housing covers.



DANGER! Make sure all guards and covers are in place and secured before operating or towing the sawmill. Failure to do so may result in serious injury. Be sure the blade housing and pulley covers are in place and secure. Use the safety retainer pin and cable to fasten blade housing covers.

IMPORTANT! After aligning the blade on the wheels, always double-check the blade guide spacing and location. (See Section 5 for more information.)

2.9 Starting The Motor

See the appropriate manual supplied with your specific motor configuration for starting and operating instructions.



DANGER! Make sure all guards and covers are in place and secured before operating or towing the sawmill. Failure to do so may result in serious injury. Be sure the blade housing and pulley covers are in place and secure. Use the safety retainer pin and cable to fasten blade housing covers.

DANGER! Check the sawmill wiring every year. Make sure all electrical installation, service and/or maintenance work is performed by a qualified electrician.

DANGER! Do not operate or leave the sawmill with the electrical boxes open. Failure to do so may cause serious injury or death.



WARNING! Always wear eye, ear, respiration, and foot protection when operating the sawmill. Failure to do so may result in serious injury.

WARNING! Be sure the power feed switch is in the neutral position before turning the key switch to the (#1) or (#2) position. This prevents accidental carriage movement, which may cause serious injury or death.

WARNING! Hazardous voltage inside the electric box is dangerous. Turn the main switch to the OFF ("0") position and lock out power supply before opening the box door!

WARNING! Hazardous voltage inside the electric control box attached to the hydraulic control box is dangerous. Turn the main switch to the OFF ("0") position and lock out power supply before opening the box door!

WARNING! The door of the electric box can be opened only when the main switch is in the "0" position. The door is closed when the switch is in the "1" position. Serious damage to the box may result while opening the door when the main switch is in the "1" position.

At least once a year the electric wires should be checked for isolation and hazardous voltage by a qualified person.

Keep the electrical starter box clean. Remove any dust or wood chips from the box from time to time. Make sure the electric box door is closed before operating the sawmill.

WARNING! Hazardous voltage inside the electric box and inside the motor can cause shock, burns, and death. Turn the main switch to the OFF ("0") position and lock out power supply before opening the box door!

The time-delay relay in the electrical starter box attached to the hydraulic box should be set between 4 and 5 seconds.

After installation, test the sawmill for proper motor rotation.

2 Setup & Operation

Board Return

If rotation is incorrect, turn the motor off pushing the STOP button located on the control box. Turn the main switch on the starter box to the OFF ("0") position. Disconnect the power cord on the left side of the starter box.

Use the screwdriver to turn the phase converter switch to the left or to the right to change the motor rotation.

2.10 Board Return

 **WARNING!** The automatic board return is intended to assist a second operator in removing boards quickly. Do not use the board return when operating the sawmill alone. Serious injury, death or damage to the equipment may result.

 **WARNING!** Never use the board return table as a platform to stand on. This table is designed and intended to assist in the removal of boards only. Standing on the table may result in serious injury.

Super sawmill models are equipped with a board return system. This system consists of an arm on the saw head controlled by a toggle switch on the control panel. A board return table is also provided to catch the board as it is removed from the log.

To install the board return table, remove the two pins securing it in its storage position at the rear of the sawmill.

See figure 2-16.

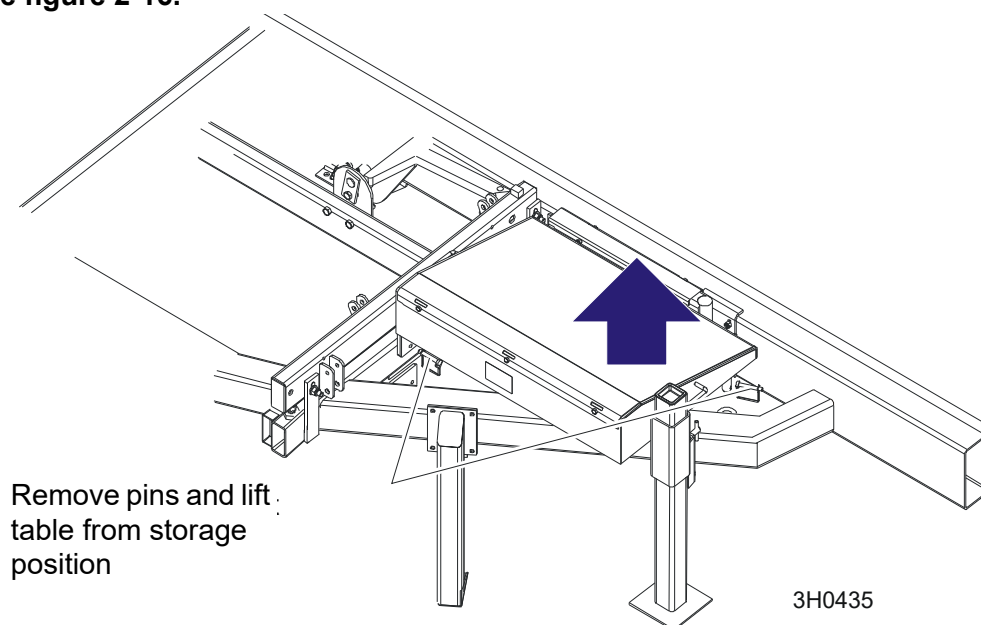

FIG. 2-16

Install the table at the front of the sawmill bed with the outrigger toward the loading side of the sawmill.

See figure 2-17. Be sure the edge of the table seats in the slot on the bed frame and the table tab seats in the leg bracket. Lower the outrigger and adjust it until it is firmly planted on the ground.

Store the pins by placing one pin in the hole under the table. Loop the second pin through the retainer of the first pin and lock.

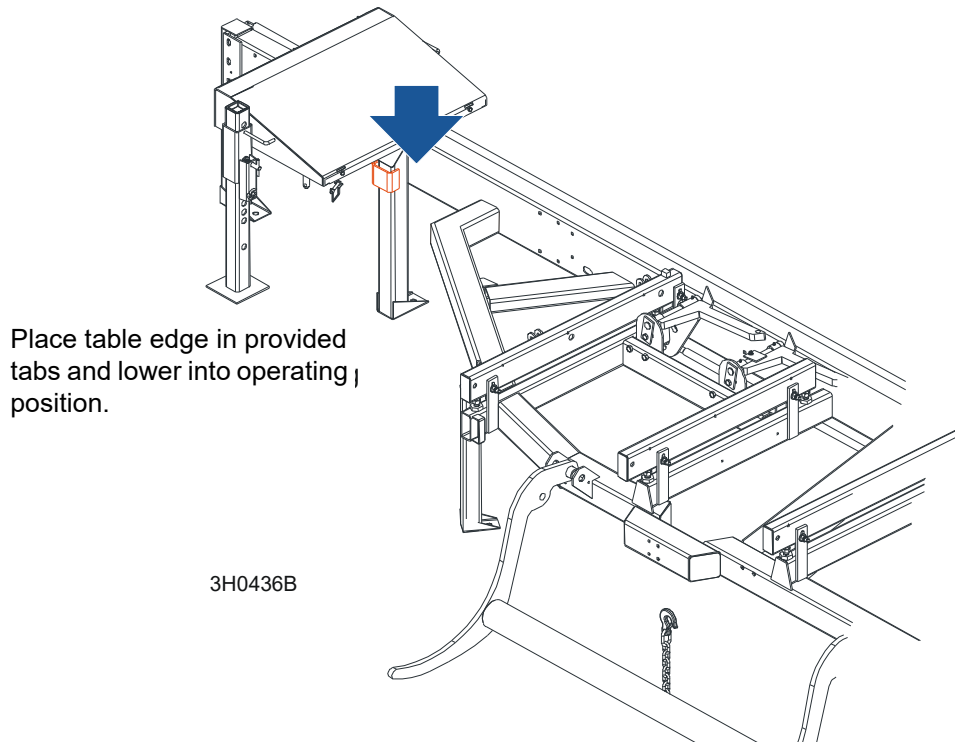

FIG. 2-17



To activate the board return, turn the key switch to the #1 position. Push the toggle switch on the control panel down. The board return arm located in the middle of the saw head will drop into position.

See figure 2-18.

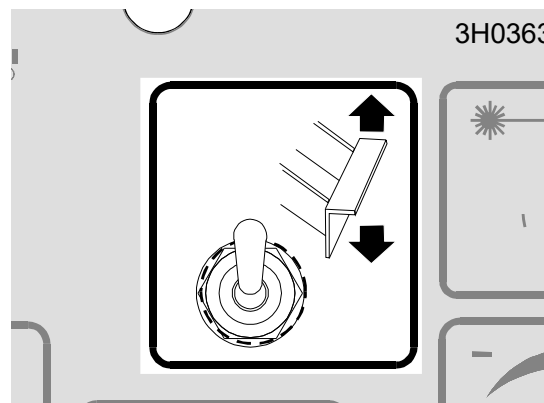

FIG. 2-18

When the blade reaches the end of the log, the arm will drop down to catch the board and drag it back toward the operator as the saw head is returned.



DANGER! Keep all persons out of the path of returning boards. Failure to do so will result in serious injury.

Boards may not always return in the same path or location. If a board returns in a manner that does not allow the sawyer or off-bearer to maintain control, it may be necessary to stop the reverse motion of the saw head.

When the board return is to be used, a second person is required to remove the board as it is returned. **DO NOT** attempt to use the board return feature when sawing alone.

To bypass the board return feature, push the toggle switch on the control panel up.

When done sawing, return the board return table to its storage position and secure with both locking pins. Adjust the outrigger leg up to provide proper ground clearance when towing the sawmill.



WARNING! To avoid damage to the board return table, secure it in its storage location before towing the sawmill.

2.11 Hydraulic Control Operation

The hydraulic control levers become operational when the contacts at the bottom of the carriage touch the power strip on the frame tube. The hydraulic control levers will only work when the cutting head is close enough to the front end of the mill to touch the power strip.

See figure 2-19. Sawmills equipped with A/DHS7 hydraulic system have fourteen control levers to load, clamp, turn and level logs.

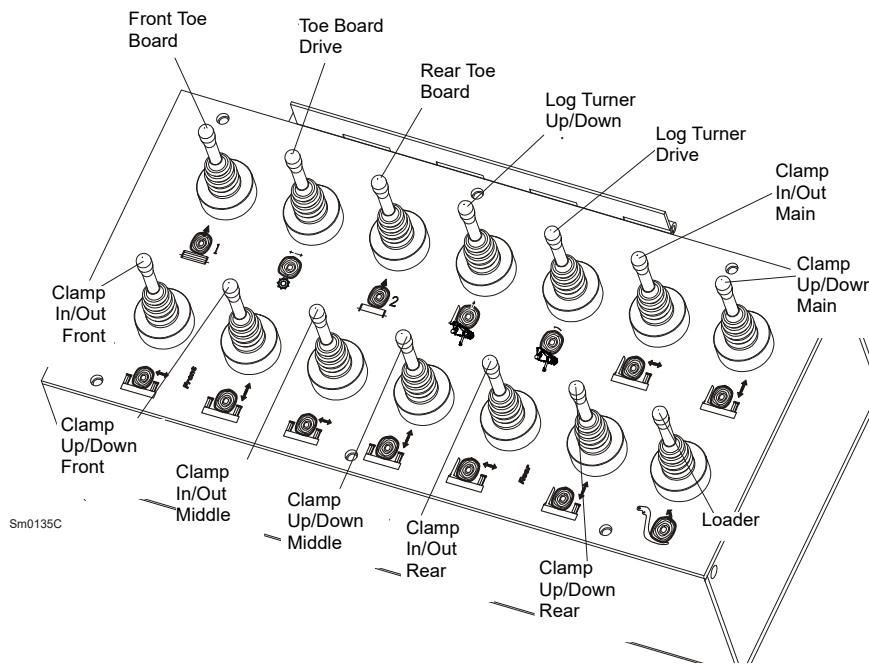

FIG. 2-19

Use the hydraulic control levers to get the mill ready to load a log.

! DANGER! Keep all persons out of the path of moving equipment and logs when operating sawmill or loading and turning logs. Failure to do so may result in serious injury.

! CAUTION! Always make sure the engine is running before operating the hydraulic controls. Operating the controls without the engine running will result in power drainage from the battery. Holding the hydraulic switches halfway up or down also will cause excessive drainage from the battery.

! Check the state of battery charge measuring the voltage every 16 hours of operation or once a week. The voltage should not be lower than 12.5V when the engine is not running and not lower than 13.8V when the engine is running (during both measurements the hydraulic system and all accessories must not work). If the voltage values are lower than the values given above, recharge the battery and check the battery charging system.

2 Setup & Operation

Loading, Turning, And Clamping Logs

1. Move the clamp out and down so it will not get in the way of logs being loaded onto the bed.

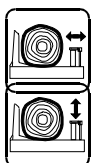

Lower the clamp in/out lever to move the clamp out toward the loading side of the sawmill.

Lower the clamp up/down lever to lower the clamp below bed level.

2. Raise the log loader lever to extend the legs of the log loader out as far as they will go .



3. The chain securing the log loading arm to the log turner arm will be tight. Raise the log turner lever to raise the turner arm until there is slack in the chain.

4. Unchain the loading arm from the turner arm.

5. Manually lower the log loader so the legs rest on the ground.



CAUTION! Be careful when manually lowering the log loader. Do not drop the loader onto the ground.

6. Lower the loader lever to lower the loading arm as far as it will go. Logs must be rolled onto the loading arm one at a time for loading onto the bed of the mill.



7. The front and rear toe boards should be below bed level. Once a tapered log has been loaded, the front or rear end of the log may be lifted to parallel the heart of the log to the path of the blade.



The front toe board is raised by lifting the front toe board lever up. The rear toe board is raised by lifting the rear toe board lever up. Once a flat has been made and the log is ready to be turned, push the appropriate toe board lever down to lower either toe board until it falls below the level of the bed.

Use the power roller to move the log forward and backward.



2.82 Loading, Turning, And Clamping Logs



CAUTION! Be sure the pivot rails, turning arm, clamp, and toe boards are below bed level before loading a log onto the bed. Failure to do so may result in machine damage or cause misalignment.

To Load Logs

1. Move a log up to the loading arm. Use cant hooks or loading equipment to move the logs to the foot of the loading arms.
2. Roll the log onto the loader so that it is approximately centered with the sawmill bed. The log turner will operate much easier if the log is centered on the sawmill bed.
3. Raise the loader lever to raise the log onto the sawmill bed. Simply let the loader rise until the log rolls onto the mill bed.



4. Lower the loading arm. Leave the loading arm about halfway up while squaring the log. This will stop the log from rolling off the side of the mill.



WARNING! Always leave loading arm halfway up while log is on sawmill bed. Failure to do so may result in serious injury or death.

NOTE: Logs also may be loaded onto the mill with a tractor or other equipment specifically designed for that purpose.

5. Raise the clamp up to prevent the log from rolling of the bed.
6. Raise the clamp up/down lever.



To Turn Logs

1. Raise the turner lever to engage the log turner arm. Let the arm rise until it touches the log and starts to turn it.



2. Spin the log against the side supports until it is turned the way you want it for the first cut. If you want to turn the log more, do the following steps.

3. Engage the clamp by raising the clamp in/out lever. Clamp the log against the side supports.



4. Lower the turner lever to lower the turner arm below the log.



5. Raise the turner arm to get a new bite on the log.
6. Disengage the clamp.
7. The log can be turned now. Repeat steps 4 through 7 until the log is turned as desired.

To Turn Logs (Optional Procedure For Hydraulic Mills Except Only)

If you are turning a small cant on a Super Series mill, you may opt to use the clamp to turn the cant.

1. Lower the clamp up/down lever to lower the clamp below bed level.
2. Raise the clamp in/out lever to move the clamp in, beneath the edge of the cant.
3. Raise the clamp up/down lever to raise the clamp and flip the cant.

To Clamp Logs

1. Raise the clamp in/out lever and clamp the log against the side supports.



2. Lower the turner lever until the turner arm falls below the bed.



3. When the turner arm is lowered all the way, the side supports will begin to lower. Back the clamp off slightly, and let the side supports come down until they are positioned below the level of your first few cuts.

To Level A Tapered Log

Use the toe board lever(s) to raise either end of a tapered log, if desired.



Raise the appropriate lever to raise the front or rear toe board until the heart of the log measures the same distance from the bed rails at each end of the log.

Pull-Down Clamps

When a cant is being cut, internal stress in the wood may cause the cant to deform slightly. The cant with internal stress tends to raise on ends. To prevent this, use two additional Pull-Down clamps. These clamps are mounted at both bed frame ends and if necessary hold the cant down so it lies flat on the bed.

2.13 Up/Down Operation

1. Install a blade, if needed, and check for correct blade tension. ([See Section 2.7](#)).
2. Set the cutting head to the desired height. (The blade height scale shows the height of the blade above the bed rails.)

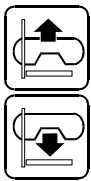

See figure 2-20. The up/down switch is located on the far right side of the control panel. Push the switch up to raise the cutting head; push the switch down to lower the cutting head. Hold the switch in position until the cutting head reaches the desired height, then release.

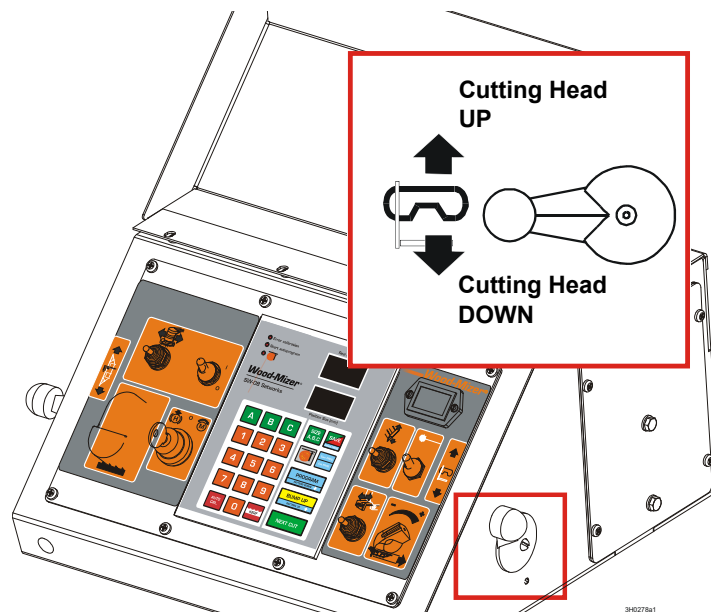

FIG. 2-20

The up/down switch is designed to return to the neutral or "off" position when released. If the switch remains engaged, manually move the switch to the neutral or "off" position. Repair the up/down drum switch ().



CAUTION! Always make sure the up/down switch moves to the neutral or "off" position when released to ensure that the saw head stops moving. Failure to do so may result in machine damage.

CAUTION! DO NOT try to force the carriage above the 35" (88 cm) mark or below the 1" (2.54 cm) mark. Damage to the up/down system may result.

2.14 Blade Guide Arm Operation

1. Look down the length of the log to see its maximum width. The outer blade guide should be adjusted to clear the widest section of the log by less than 1" (25.4 mm).
2. Use the blade guide toggle switch on the control panel to adjust the outer blade guide as necessary. Push the switch to the left to move the arm in. Push the switch to the right to move the arm out.

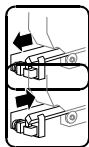

See figure 2-21.

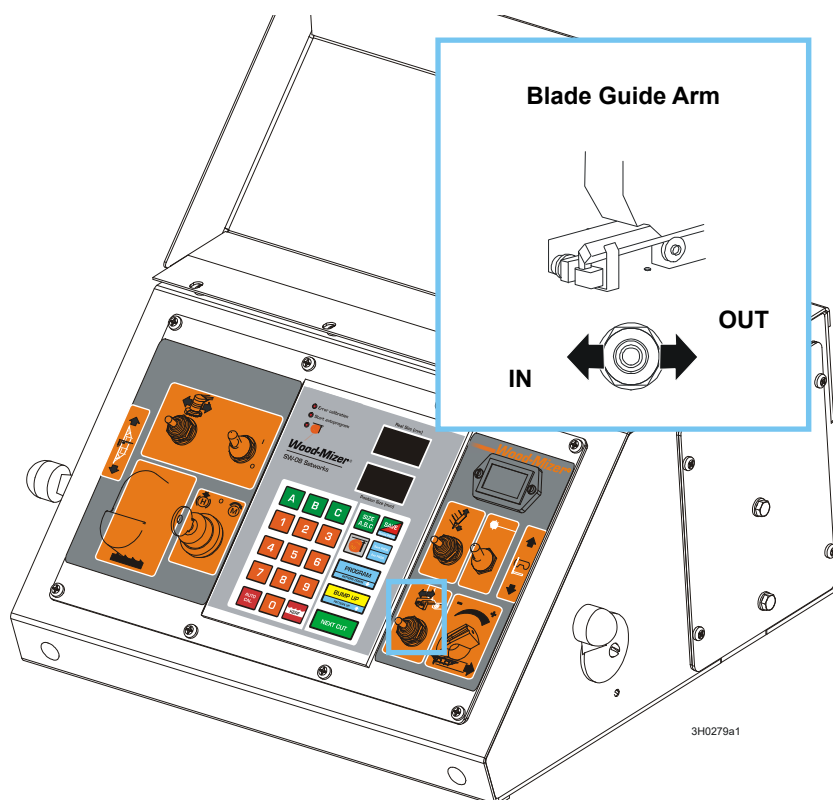

FIG. 2-21

3. Use the blade guide toggle switch to readjust the outer blade guide as you are cutting in order to keep the guide within 1" (2.5 cm) of the log. Be sure to adjust the arm back out before returning the carriage.

2.15 Power Feed Operation

See figure 2-22. The power feed system moves the carriage forward and backward by using two switches on the control panel.

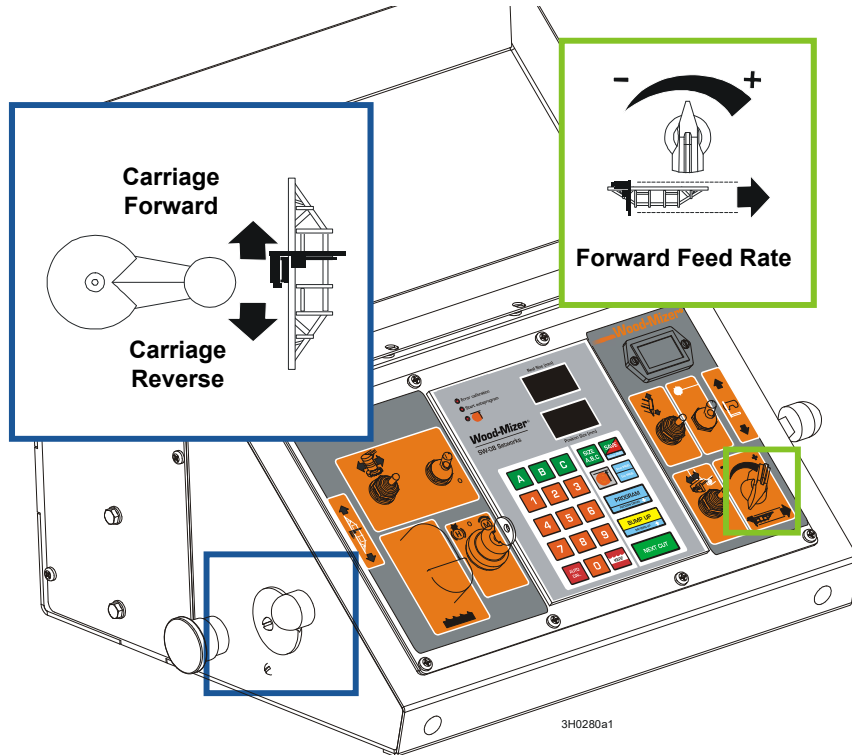

FIG. 2-22

Carriage Feed Rate



The carriage feed rate switch controls the speed at which the carriage travels forward. Turn the switch clockwise to increase speed. Turn it counterclockwise to reduce speed.

Carriage Forward and Reverse

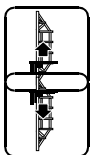

The carriage forward/reverse switch controls the direction in which the carriage travels. Turn the forward/reverse switch upward to move the carriage forward. Turn the switch down to move the carriage backward.

The middle position (as shown) is the neutral position. The power feed switch is designed to return to the neutral or "off" position when released from operating in the reverse position. If the switch remains engaged, manually move the switch to the neutral or "off" position. Repair the drum switch ([See Section 4.2](#)).



WARNING! Be sure the power feed switch is in the neutral position before turning the key switch to the (#2) or (#1) position. This prevents accidental carriage movement, which may cause serious injury or death.

2 Setup & Operation

Power Feed Operation

Using The Power Feed

HINT: To get a straight cut in the first part of the board, feed the blade into the log at a slow speed. This stops the blade from flexing and dipping up or down. Turn the carriage feed rate switch to a slow speed until the whole width of the blade has entered the cut. Then use the carriage feed rate switch to increase the feed rate as desired. Maximum feed rate varies with width and hardness of the wood. Over-feeding results in engine and blade wear, and also produces a wavy cut.



Stop the carriage at the end of the cut by turning the carriage feed rate switch counterclockwise until the carriage stops moving.



2. Push the STOP button to stop the blade. Remove the board from the top of the log.



CAUTION! Be sure to stop the blade when returning the carriage. This will not only prevent the blade from being pulled off and ruined by a wood sliver, but also will increase the life of the blade. [See Section 2.18](#) for optional procedure for Super series mills.

3. Return the carriage to the front of the mill by turning the carriage forward/reverse switch down. **Always disengage the blade before returning the carriage for the next cut.** [See Section 2.18](#) for optional procedure for Super series mills.



IMPORTANT! When using a sawmill it is very important not to switch between saw head forward/backward movement until the saw head stops. Failure to do so may result in serious sawmill damage.

4. Make sure that the blade does not catch on the end of the log. Raise the carriage slightly to make sure the blade clears the log when returned. **HINT:** Try to stop the blade while the heel of the blade is still on the log. Then bring the carriage back without adjusting the blade up. This lets you keep the blade at the current height setting so you can make the next blade height adjustment more quickly.



DANGER! Stay clear of the area between the trailer axle and saw carriage. Failure to do so will result in serious injury.

2.16 Cutting The Log

The following steps guide you through normal operation of the Wood-Mizer sawmill.

1. Once the log is placed where you want it and clamped firmly, turn the key switch to the accessory (#1) position.



2. Use the blade height scale to determine where to make your first cut ([See Section 2.19](#)). The blade height scale will help you to do this. Set the blade to the desired height with the up/down switch. Make sure that the blade will clear all side supports and the clamp. Adjust the outer blade guide to clear the widest section of the log by moving the blade guide toggle switch.

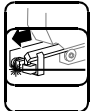

NOTE: An optional laser sight is available to help determine where the blade will travel through the log. See the laser sight manual for detailed operating instructions.

3. Make sure all covers and guards are in place. Push the START button to start the blade spinning.
4. Start the water lube if necessary to prevent sap buildup on the blade. [See Section 2.20](#).

5. If you want to use the board return function, push the toggle switch on the control panel down. [See Section 2.10](#).

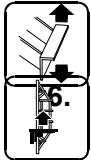

6. Feed the blade into the log slowly ([See Section 2.15](#)). Once the blade completely enters the log, increase the feed rate as desired. Always try to cut at the fastest speed you can while keeping an accurate cut. Cutting too slowly will waste blade life and lower production!



As you get to the end of the log, slow down the feed rate. When the teeth exit the end of the log, turn the feed rate all the way down. Push the STOP button to stop the motor. Remove the slab that you have just cut from the log.

8. Use the carriage forward/reverse switch to return the carriage to the front of the mill. Always disengage the blade before returning the carriage for the next cut.



9. Repeat until the first side of the log is cut as desired. Set aside the usable flitches (boards with bark on one or both sides). You can edge them on the mill later.

10. Lower the toe boards, if they were used. Use the hydraulic levers to release the clamp and engage the log turner. Turn the log 90 or 180 degrees. Make sure the flat on the log is placed flat against side supports if turned 90 degrees. Make sure it is placed on bed rails if turned 180 degrees. If the log was turned 90 degrees and you are using toe boards to compensate for taper in the log, raise the front or rear toe board again on the second side of the log until the heart is parallel with the bed.



11. Repeat the steps used to cut the first side of the log until the log is square. Cut boards from the remaining cant by adjusting the blade height for the thickness of boards that you want.

Example: Remember that the blade cuts a 1/16 - 1/8" (1.6-3.2 mm) wide kerf. If you want 1" (25.4 mm) thick boards, lower the carriage 1 1/16 - 1 1/8" (27-28.6 mm) for each board.

2.17 Edging

The following steps guide you through edging boards on the Wood-Mizer sawmill.

1. Raise the side supports to 1/2 the height of the flitches, or the boards that need to be edged.
2. Stack the flitches on edge against the side supports.
3. Clamp the flitches against the side supports halfway up the flitch height. (Wider flitches should be placed to the clamp side. When they are edged, flip them over to edge the second side without disturbing the other flitches or without having to pull them from the middle of the stack).
4. Adjust the blade height to edge a few of the widest boards.
5. Loosen the clamp and turn the edged boards over to edge the other side.
6. Repeat steps 2-4.
7. Loosen the clamp and remove the boards that have good clean edges on both sides. Clamp the remaining flitches and repeat steps 2-5.

2.18 Optional Cutting Procedure for Super Series Mills

In order to achieve maximum production rates with Super Series mills; it may be desirable to leave the blade engaged when returning the carriage. (Normal operation procedures recommend disengaging the blade before returning the carriage for maximum blade life and fuel economy.)

 **DANGER!** If leaving the blade engaged for maximum production rates, make sure the off-bearer stays out of the path of the blade. Failure to do so will result in serious injury or death.

 **CAUTION!** If you choose to leave the blade engaged; raise the blade to clear the log before returning the carriage. Failure to do so may cause damage to the blade and/or sawmill.

2.19 Blade Height Scale

See figure 2-23. The blade height scale is attached to the carriage head frame. It includes:

- a blade height indicator
- an inch scale
- a quarter scale

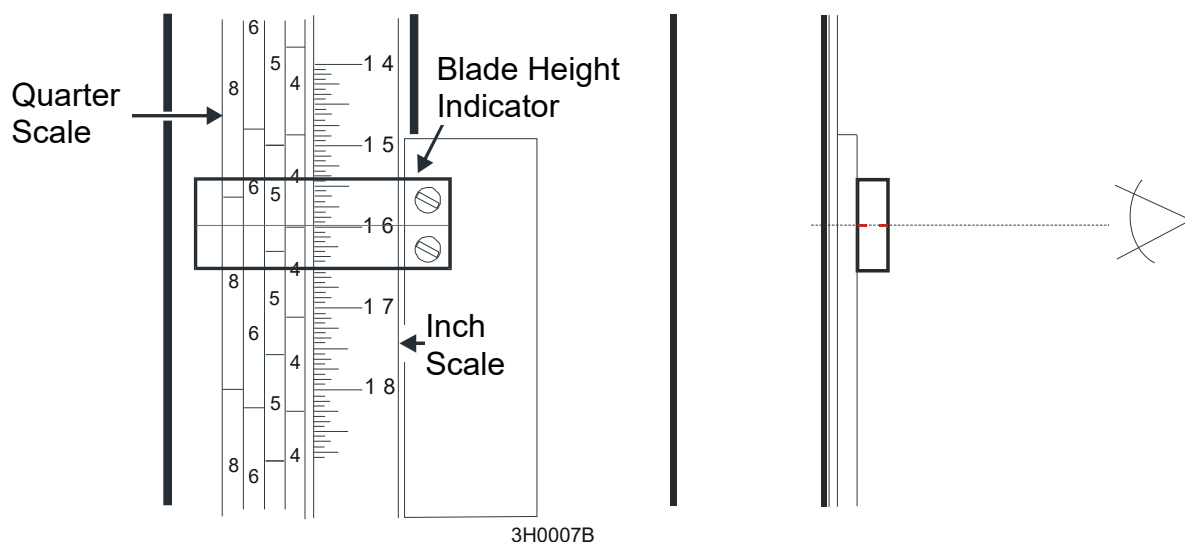

FIG. 2-23

The scales are attached to the frame and move up and down with the carriage head. The blade indicator, used to read the inch and quarter scales, remains stationary.

Blade Height Indicator

The blade height indicator has two horizontal, red lines on both sides. Readings should be taken with eyes level with the indicator, when the two red lines are in line. This will allow to avoid the parallax error (different scale readings depending on the angle of vision).

The Inch Scale

The horizontal red line on the blade height indicator shows how many inches the bottom of the blade is above the bed of the mill. If you know the height of your blade at each cut, you can determine the thickness of lumber you are sawing.

Example: You want to cut 1" (25 mm) random width boards from a log. Position the blade for the first cut. Move the carriage to an even measurement on the inch scale. Make a trim cut. Return the carriage for the second cut and lower it 1 1/8" (29 mm) below the original measurement. (The extra 1/8" (3 mm) allows for saw kerf and shrinkage of the lumber.)

The yellow area on the scale identifies where the blade could encounter a side support or log clamp. Check that these items are below the blade level before sawing.

The Quarter Scale

See Table 2-3. Two quarter scales are provided with four sets of marks. Each set represents a specific lumber thickness. Saw kerf and shrinkage allowance are included, but actual board thickness will vary slightly depending on blade thickness and tooth set.

To choose which scale to use, determine what finished thickness you want to end up with. The Grade Hardwood Quarter Scale provides thicker finished boards usually required by commercial buyers. The Standard Quarter Scale allows for kerf and shrinkage of finished boards suitable for most custom applications. Always check with your customer before you saw to determine what actual finished thickness is required.

Standard Quarter Scale		Grade Hardwood Quarter Scale	
Scale	Actual Board Thickness	Scale	Actual Board Thickness
4/4	1" (25 mm)	4/4	1 1/8" (29 mm)
5/4	1 1/4" (32 mm)	5/4	1 3/8" (35 mm)
6/4	1 1/2" (38 mm)	6/4	1 5/8" (41 mm)
8/4	2" (51 mm)	8/4	2 1/8" (54 mm)

TABLE 2-3

To use the quarter scale, look at the blade height indicator. Line up the horizontal red line on the indicator with the nearest mark on the scale you want to use. Make a trim cut. When you return the carriage for a second cut, lower the carriage to the next mark on the scale. This mark shows where the blade should be positioned to cut a certain thickness of lumber, without having to measure on the inch scale.

Example: You want to cut 1" (25 mm) (4/4) random width boards from a log. Position the blade for the first cut. Adjust the quarter scale so a 4/4 mark is aligned with the red line on the indicator. Make a trim cut. Return the carriage for the second cut. Now, instead of having to measure down 1 1/8" (29 mm) on the inch scale, you can simply lower the blade so the indicator is aligned with the next 4/4 mark on the quarter scale. Turn the log 90 degrees and repeat.

2.20 Water Lube Operation

See figure 2-24. The Water Lube System keeps the blade clean. Water flows from a 5-gallon (18.9 liter) bottle through a hose to the blade guide where the blade enters the log. A valve in the bottle cap controls the amount of water flow.

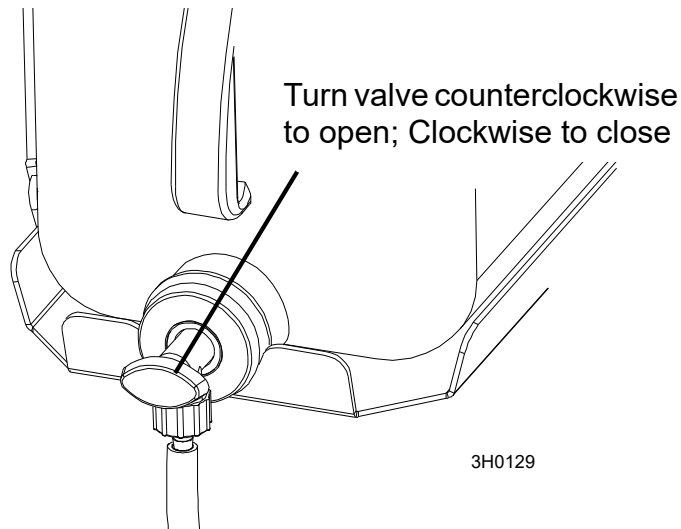

FIG. 2-24

Super models include a solenoid valve that will automatically start the water flow when the power feed is activated in the forward direction. The solenoid will stop the water flow when the feed switch is returned to the neutral position.

Not all types of wood require the use of the Water Lube System. When it is needed, use just enough water to keep the blade clean. This saves water, and lowers the risk of staining the boards with water. Usual flow will be 1-2 gallons (3.8-7.6 liters) per hour. A squirt of liquid dishwashing detergent in the water bottle will help clean the blade when cutting wood with a high sap content.



WARNING! Use ONLY water with the water lube accessory. Never use flammable fuels or liquids. If these types of liquids are necessary to clean the blade, remove it and clean with a rag. Failure to do so may result in serious injury or death.

Before removing the blade, start the motor. Let the blade spin with water running on it for about 15 seconds. This will clean the blade of sap buildup. Wipe the blade dry with a rag before storing or sharpening.

If you are sawing in freezing temperatures, remove the water lube bottle from the sawmill when done sawing and store it in a warm place. Blow any remaining water from the water lube hose.

To remove water from the water valve on Super models, turn the key switch to accessory (#1), turn the feed rate knob down to '0' and place the feed switch in the forward position. Blow any remaining water from the water lube hose and valve. Return the forward/reverse switch to neutral and turn the key switch to off (#0).

2.21 Preparing The Sawmill For Transportation

The Wood-Mizer trailer package for the LT40 sawmills makes transporting your sawmill easy and convenient. To get your sawmill ready for towing, follow these instructions.

1. Move the saw carriage to the front end of the sawmill. Raise the rear outriggers.
2. Move the clamp to the main bed rail as close as possible.



CAUTION! Move the hydraulic clamp and turner to provide maximum ground clearance before towing. Failure to do so may result in damage to the sawmill.

3. Move the carriage forward to the travel position over the bed rail. Position the hole in the saw head over the travel rest pin.
4. Secure the rest pin using locking pin.

See figure 2-25.

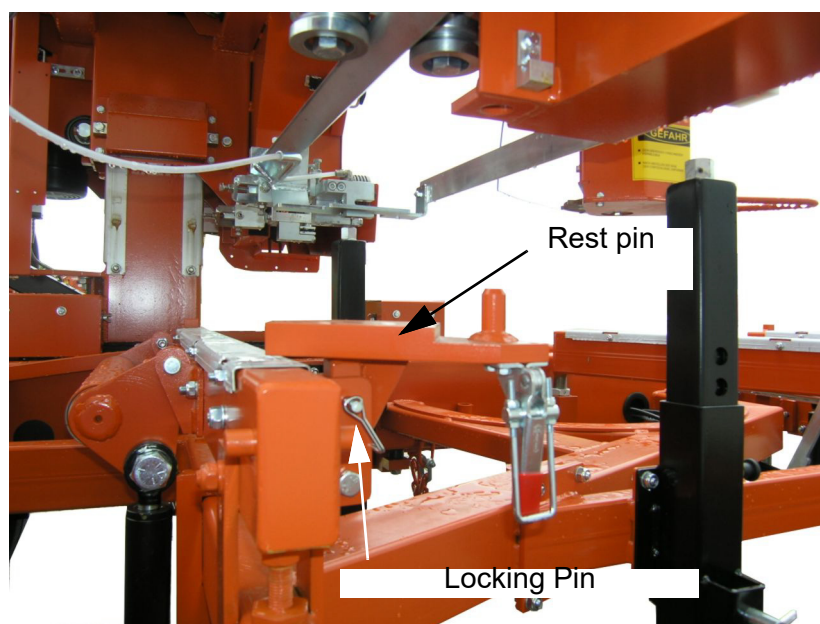

FIG. 2-25

5. Lower the saw head until it is it contacts the stop blocks on the mast rails. Secure the saw head with locking clamp.

See figure 2-26.

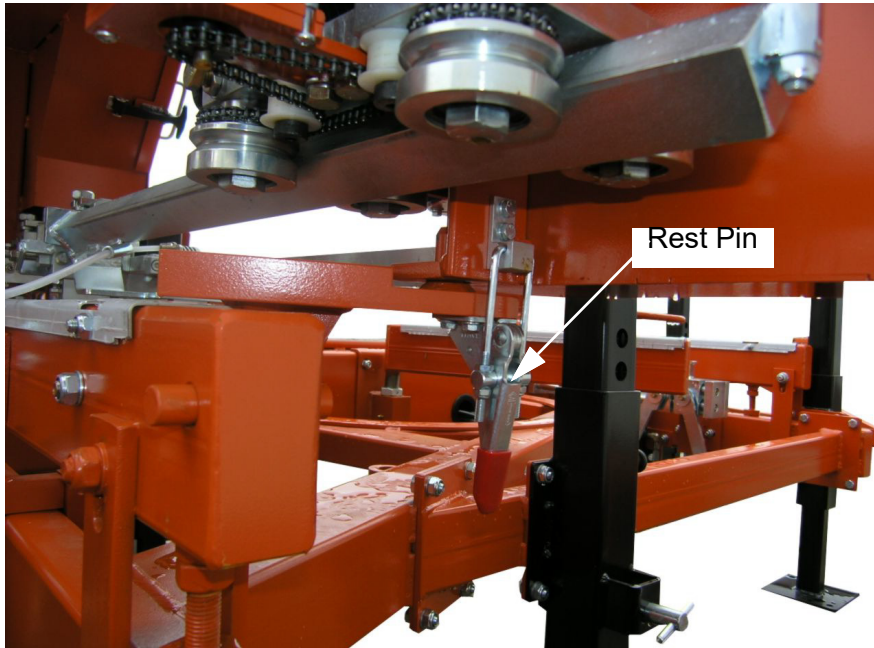

FIG. 2-26



CAUTION! It is important that the lower stop bolts are properly adjusted to secure the carriage on the track rail. Failure to properly adjust the stop bolts can cause saw head damage, especially during mill transportation.

6. If necessary, adjust the two stops located at the bottom of the mast so the saw head contacts them after it is lowered $\frac{3}{4}$ " (19mm) past where it contacts the rest pin.

See figure 2-27.

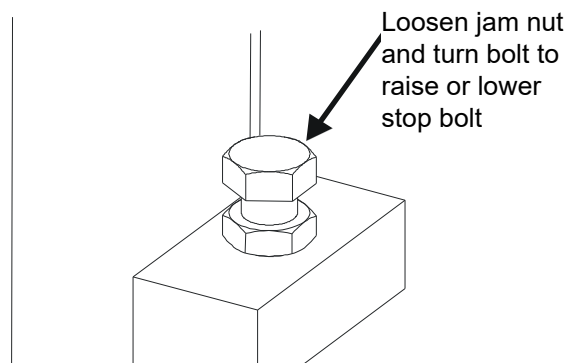

FIG. 2-27

7. Use the hydraulic controls to raise the log turner and loader as high as they will go. Manually lift the loader and hook the loader chain to the elbow of the turner. Use the hydraulic turner lever to lower the turner until the chain is tight. Push the loader lever down to bring the loader arm channels up to the loader.

8. Mount the control box blockade on the saw head track rails. Lock hydraulic control box by inserting the locking pin into the hole of the control box blockade.

SECTION 3 MAINTENANCE

This section lists the maintenance procedures that need to be performed.



WARNING! Disconnect and lock out power supply before servicing, cleaning and performing maintenance to the saw! Failure to do so may result in serious injury.

The Short Interval Maintenance Schedule lists procedures that need to be performed every 4, 8 or 25 hours. The Maintenance Log lists procedures that need to be performed every 50, 100, 200, or 1000 hours. Keep track of machine maintenance by filling in the machine hours and the date you perform each procedure.



This symbol identifies the interval (hours of operation) at which each maintenance procedure should be performed.

Be sure to refer to option and engine manuals for other maintenance procedures.

3.1 Wear Life

See Table 3-1. This chart lists estimated life expectancy of common replacement parts if proper maintenance and operation procedures are followed. Due to the many variables which exist during sawmill operation, actual part life may vary significantly. This information is provided so that you may plan ahead in ordering replacement parts.

Part Description	Estimated Life
B57 Blade Wheel Belts	500 hours
Up/Down Motor	2000 hours
Up/Down Drum Switch	1000 hours
Blade Guide Rollers	1000 hours
Power Feed Drum Switch	1200 hours
Drive Belt	1250 hours
Power Feed Motor	1500 hours
Power Feed Belt	2000 hours
Up/Down Belt	2000 hours

TABLE 3-1

3.2 Blade Guides

1. Check the rollers for performance and wear every blade change. Make sure the rollers are clean and spinning freely. If not, rebuild them. Replace any rollers which have worn smooth or have become cone shaped. See The LT40 AH Parts manual for blade guide rebuild kits and complete roller assemblies.

Steel Blade Guide Blocks

2. Inspect the blocks at every blade change for damage or wear. If the block housing is bent or damaged, replace the block assembly.

As the blocks wear, the front inside corner will wear more than the body of the block. When the corner wears far enough, sawing performance will be affected even if the body of the block is adjusted properly to the blade. At this point, the block should be replaced. If you have access to the appropriate equipment, you can grind or mill the blocks to a new flat surface and reuse them. It is recommended you develop a routine schedule for replacing the blade guide blocks based on your sawing conditions and experience.

See Figure 3-1.

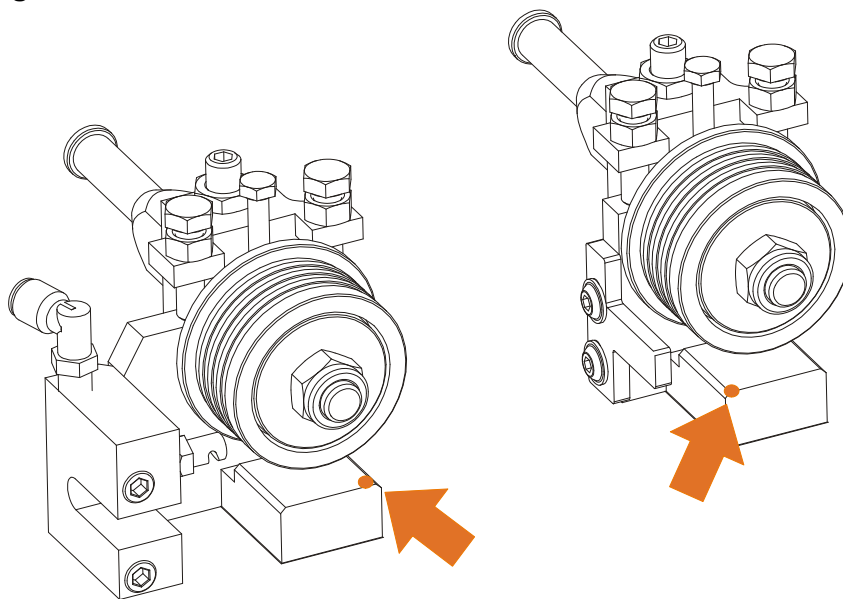

FIG. 3-1

3. Check the inserts are properly spaced from the bottom of the blade every 25 hours of operation. As the rollers wear, the gap between the blade and inserts will become larger. Use the provided shim or a feeler gauge to check the inserts are adjusted 0,3 - 0,5 mm from the blade.

To adjust the disks up, loosen the bottom guide disk mounting bolt and clamp bolt. Use the provided adjustment tool to raise bottom disk. Retighten the bottom disk mounting bolt and clamp bolt.



IMPORTANT! The inserts should be parallel to the blade. Check the space between the insert and the blade at each side of the insert to insure it is parallel. Use the appropriate outer adjustment bolt to tilt the insert mounting plate so the insert is parallel to the blade.

After adjusting the drive side blade guide block insert up, check the deflector. If necessary, loosen the two deflector mounting screws and adjust the deflector so it does not touch the blade.

See Figure 3-2.

4. Make sure the blade screw in the top center of the C-frame is 1/16" (1.5 mm) below the bottom of the blade. If not, loosen the nut and adjust the screw as necessary. Check the screw every blade change. Failing to maintain this adjustment will lead to early blade breakage.

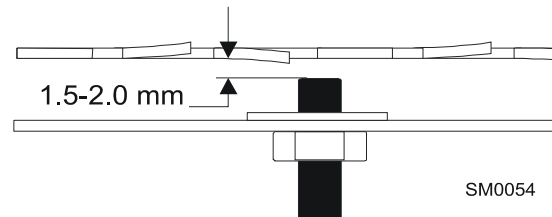

FIG. 3-2

3.3 Sawdust Removal

1. Remove the excess sawdust from the blade wheel housings and sawdust chute every blade change.
2. Remove sawdust buildup as necessary from top rail cover.



CAUTION! Failure to remove sawdust buildup from track rail cover could result in damage to these parts when the saw head is lowered to its lowest position.



3. As required, remove sawdust buildup from the power feed belt housing. Turn the control panel key switch to OFF (0) and remove the key. Disassemble the power feed belt cover and remove sawdust buildup in and around the power feed belt and pulleys. Replace the power feed belt cover.

3.4 Carriage Track, Wiper & Scrapers

See Figure 3-3.

- 8 **1.** Clean the upper and lower track rails to remove any sawdust and sap buildup every eight hours of operation. Lubricate the lower track rail by wiping it with Dexron III ATF.
- 8 **2.** Remove sawdust from the upper cam housings. Loosen the thumb screws on the upper cam housing covers and open. Brush any sawdust buildup from the housings.
- 3.** Check the track scrapers as needed. Make sure the scrapers fit firmly against the rail. If a track scraper needs to be adjusted, loosen the thumb screw, push the scraper downward until it fits firmly against the rail, and retighten the thumb screw.

25 Clean and lubricate the upper track wiper every twenty-five hours of operation. Unbolt the wiper, remove it from the sawmill, and remove any sawdust buildup. Soak the felt wiper with Dexron III transmission fluid, 10W30 motor oil or 3-in-1 turbine oil.

CAUTION! Reinstall the track wiper so that it lightly touches the track rail. If the wiper presses too firmly against the rail, it can cause the power feed to bind.

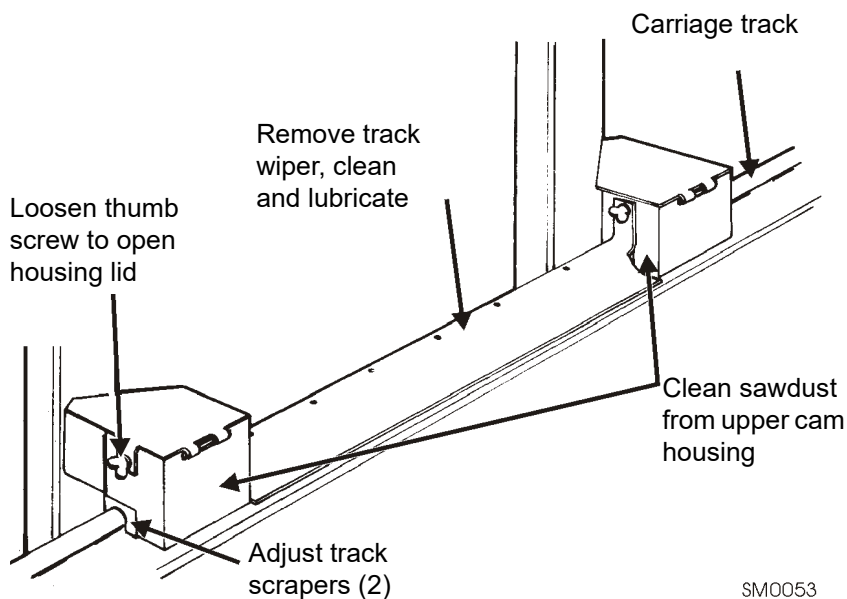



FIG. 3-3

3.5 Vertical Mast Rails

 Clean and lubricate the vertical mast rails every 50 hours of operation. Clean with solvent and remove any rust with a light-grade sand paper or emery cloth. Lubricate the mast with motor oil or automatic transmission fluid (ATF).



CAUTION! Never use grease on the mast rails as it will collect sawdust.

3.6 Drum Switches

 Lubricate the up/down and power feed drum switch contacts inside the control panel every fifty hours of operation. Use only contact grease supplied by Wood-Mizer. Remove the control panel cover. Use a cotton swab to apply grease to the switch contact ends.



WARNING! Drum switch grease contains Petroleum Hydrocarbon Lubricant. Eye and skin irritant. If introduced into eyes, flush with water for at least 15 minutes. If film or irritation persists, seek medical attention. Wash skin with soap and water. If ingested, do not induce vomiting - contact a physician. **KEEP OUT OF THE REACH OF CHILDREN.**

3.7 Miscellaneous

 1. Apply a thin film of a NLGI No. 2 grade lithium grease to the blade guide arm every fifty hours of operation to help prevent it from rusting.

2. Lubricate the log turner (if equipped) with a NLGI No. 2 grade lithium grease every fifty hours of operation. Lubricate the turner pivot pins with WD-40 or a dry lube.



 3. Grease the side supports with a NLGI No. 2 grade lithium grease every fifty hours of operation.



 4. Oil all chains with Dexron III ATF every fifty hours of operation.





CAUTION! Do not use chain lube. It causes sawdust buildup in chain links.

 5. Lubricate the board return pivot every fifty hours of operation with a NLGI No. 2 grade lithium grease. Apply grease to the grease fitting on the board return pivot tube.



6. Check the mill alignment every setup. See Section 5, Alignment.

7. Make sure all safety warning decals are readable. Remove sawdust and dirt. Replace any damaged or unreadable decals immediately. Order decals from your Customer Service Representative.

8. Lubricate the clutch lever bushings every 200 hours of operation (or once a month). Apply lithium grease to the fitting.

3.8 Blade Tensioner

1. Lubricate the chrome rods of the tensioner system with a heavy duty teflon spray lubricant, such as Gunk L508, every 50 hours of operation.

50

2. Lubricate the tensioner screw handle with a NLGI No. 2 grade lithium grease as needed.

See Figure 3-4.

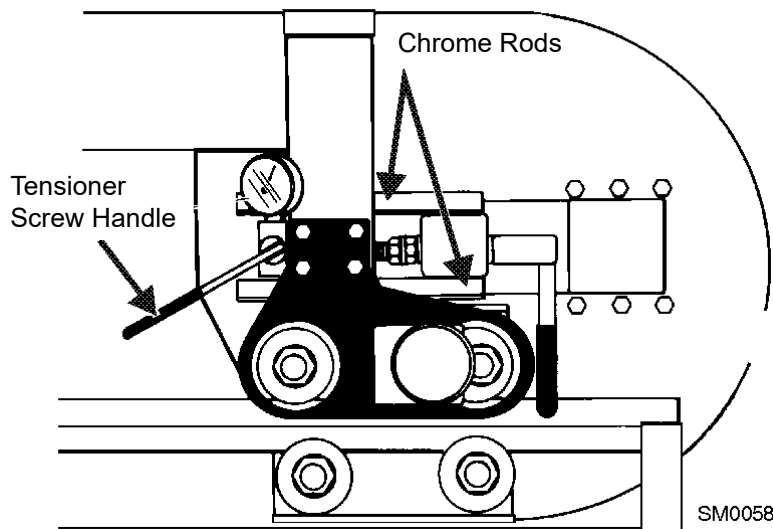

FIG. 3-4

3. Add an Automatic Transmission Fluid (ATF) such as Dexron III ATF to the hydraulic blade tensioner as needed.

See Figure 3-5. To add enough fluid to completely fill the tensioner block:

- Remove the tensioner handle and ball. Remove the sawmill blade housing covers, blade and idle-side blade wheel.
- Push the idle-side shaft housing all the way in to collapse the rear tensioner piston and fully extend the front piston. The front piston should reach the threaded area of the piston guide.

NOTE: If the hydraulic fluid level is extremely low, collapsing the rear piston may not fully extend the front piston. If it does not, finish the fill procedure in its entirety and repeat. The first pass should add enough fluid to allow the front piston to fully extend. The second pass should add enough fluid to completely fill the block.

- Locate the fill plug behind the tension gauge. Clean any dirt and debris from the plug area. Use a 7/16" wrench to remove the plug, making sure to keep the plug o-ring with the plug.
- Manually extend the rear piston (the front piston should remain extended).

- Use a small funnel or cup to completely fill the block with hydraulic fluid. When full, place the fill plug in the fill plug hole and thread 1-2 turns. Manually push the rear piston all the way in to allow excess oil and air to bleed from system through the plug. Tighten the plug all the way.
- Reinstall the idle-side blade wheel, blade and blade housing covers. Reinstall the tensioner ball and handle.

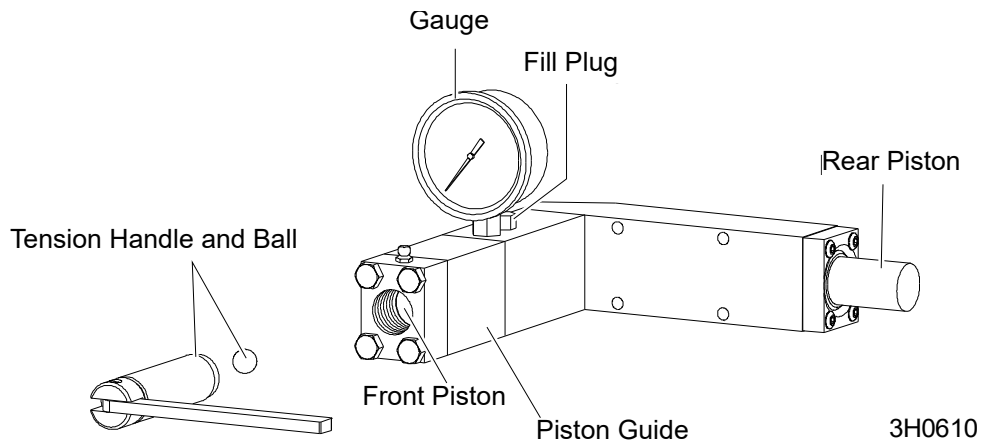

FIG. 3-5

3.9 Blade Wheel Belts

- 50 1. Rotate the blade wheel belts and check them for wear. Rotating the belts every 50 hours will give you longer belt life. Replace belts as necessary. Use only B57 belts manufactured by Goodyear or Browning.
2. Periodically check all belts for wear. Replace any damaged or worn belts as needed.

3.10 Drive Belt Adjustment

WARNING! Do not for any reason adjust the engine drive belts or belt support bracket with the engine running. Doing so may result in serious injury.

50 **See Table 3-2.** Check the drive belt tension after the first 20 hours, and every 50 hours thereafter. See the table below for drive belt tension specifications for your model sawmill.

Engine/Motor	Belt Tension
E20	7/16" (11mm) deflection with 16 lbs. of deflection force
E25	7/16" (11mm) deflection with 16 lbs. of deflection force

TABLE 3-2

3.11 Drive Bearing

500

Refill the fluid in the drive-side cylinder bearing housing every 500 hours of operation. Remove the top and bottom oil plugs. Pour an Automatic Transmission Fluid (ATF) such as Dexron III ATF into the top hole until it begins to flow from the bottom hole. Reinstall the square oil plug to the bottom hole and the vented oil plug to the top hole.

See Figure 3-6.

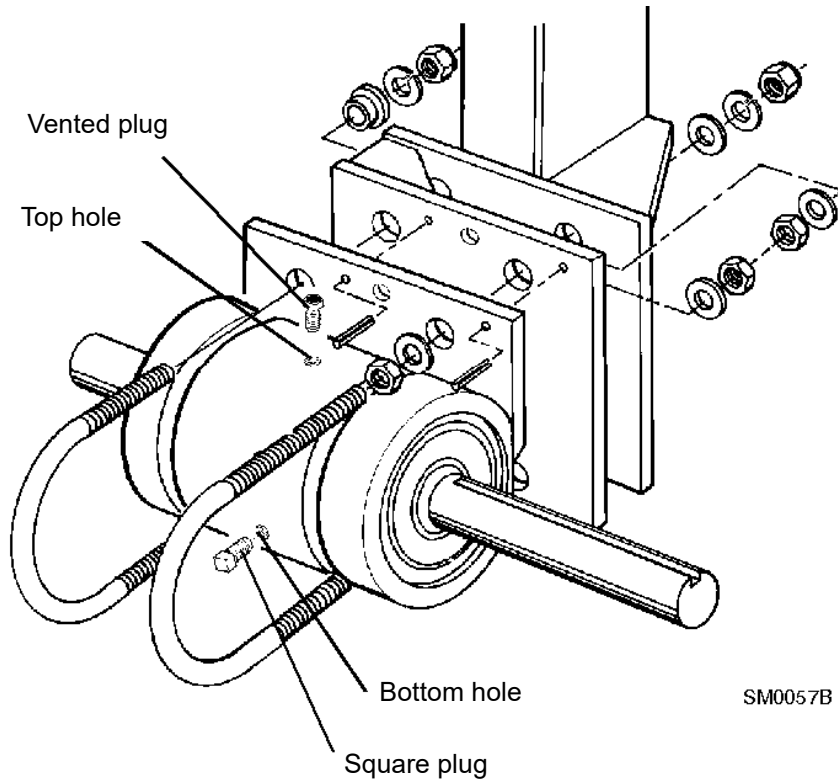

FIG. 3-6

3.12 Up/Down System

1. Grease the up/down gear reducer shaft bearing with a NLGI No. 2 grade lithium grease every 1000 hours of operation.

See Figure 3-7.

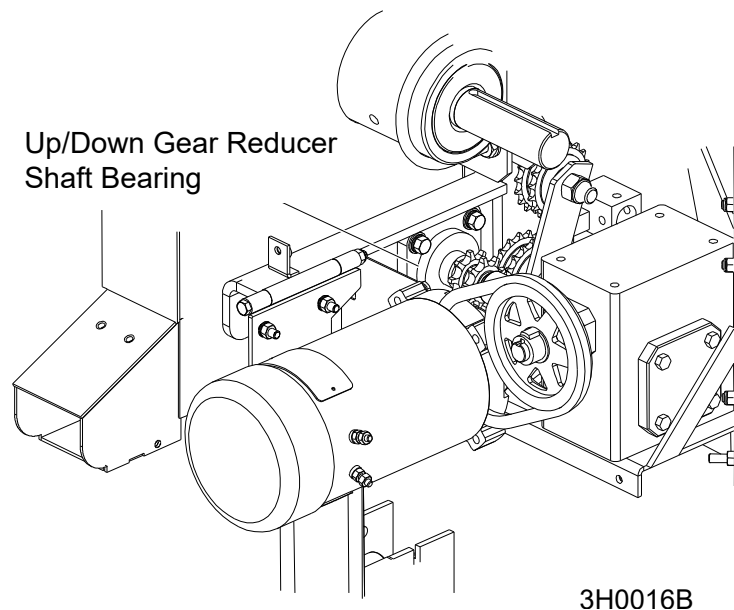





FIG. 3-7

2. Super model up/down systems feature a spring loaded belt design. Belt tension is automatically maintained and requires no adjustment. Replace the belt when adequate belt tension can no longer be obtained.

 **WARNING!** Always secure the cutting head with a chain or a brace before removing the up/down motor belt. The cutting head may fall, causing severe injury or death.

3. Adjust the up/down chain tension as needed. Measure chain tension with the head all the way to the top of the vertical mast. Secure the carriage with a chain at the top, or shim it underneath. Find the chain adjusting bolt at the bottom of the mast, behind the battery box. Adjust the bolt until the center of the chain can be deflected 3/4" (1.9cm) forward and 3/4" (1.9cm) backward with a 5 lb. (2.3 Kg) deflection force.

 **WARNING!** Always secure the cutting head with a chain or a brace before adjusting the up/down chain. The cutting head may fall, causing severe injury or death.

 **CAUTION!** Do not overtension the chain. Overtensioning the chain may lead to early failure of the gear reducer.

See Figure 3-8.

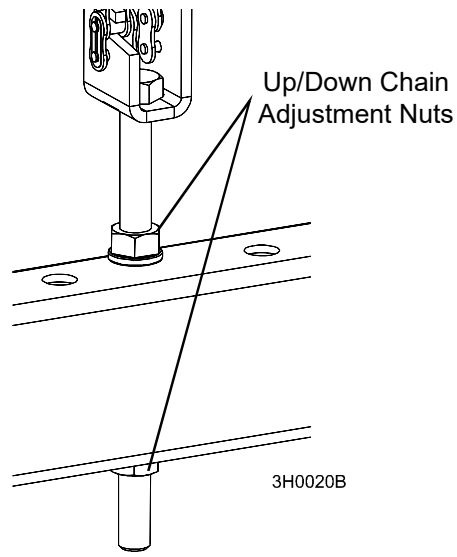
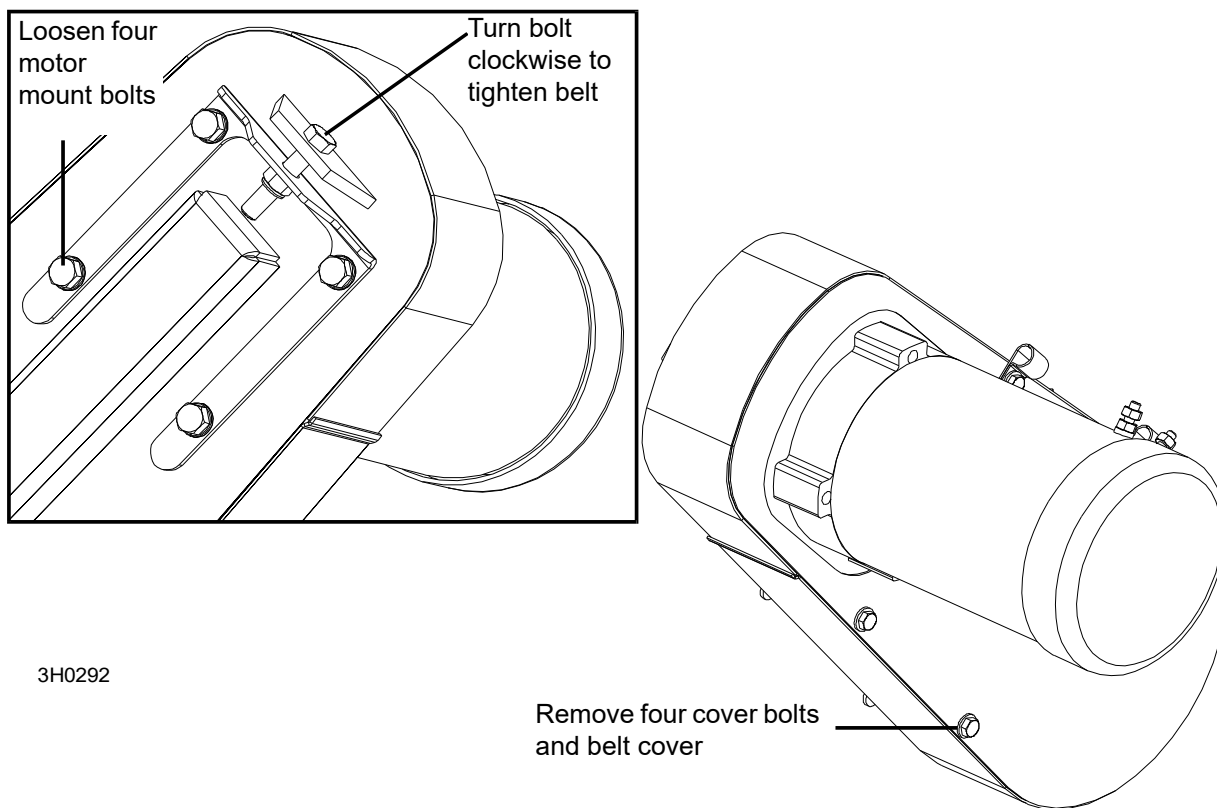

FIG. 3-8

3.13 Power Feed

1. Adjust the power feed belt as needed. When the power feed belt gets loose, it will begin slipping. This causes the carriage to not move forward when cutting. To retighten the belt:

See Figure 3-9. Remove the four cover bolts and belt cover and measure the belt tension. The belt should be tightened so there is 1/8" (3 mm) deflection with a 7 lb. (3.2 Kg) deflection force. To adjust the belt tension, loosen the four motor mount bolts. Place a wrench on the jam nut and turn the adjustment bolt clockwise to tighten the belt. Retighten the motor bolts and replace the feed motor cover.



3H0292

FIG. 3-9

2. Adjust the power feed chain as needed. Measure the power feed chain tension with the saw head all the way toward the front of the mill. Use the two lock nuts at the rear of the mill to tighten or loosen the power feed chain. Adjust the chain until it measures 7 to 8 inches (17.8 to 20.3 cm) from the top of the top rail at its lowest point.



CAUTION! Do not overtighten the feed chain. Damage to the power feed motor may result.

See Figure 3-10.

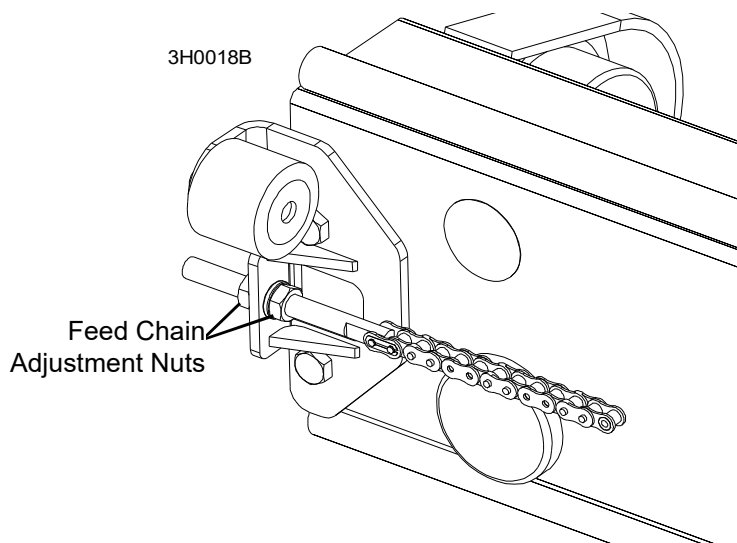

FIG. 3-10

3.14 Safety Devices Inspection

LT40 AC – Safety devices inspection

Safety devices on the LT20AC machine which must be checked before every shift:

- E-STOP button and its circuit inspection
- Inspection of the control circuits with the E-STOP button pressed
- Blade cover safety switches and its circuit inspection
- Motor brake and its circuit inspection

1. E-STOP button and its circuit inspection

- Turn on the blade motor;
- Press the E-STOP button located on the left side of the control box. The blade motor should be stopped. Pressing the START button should not start the motor until the E-STOP button is released.

See Figure 3-11.

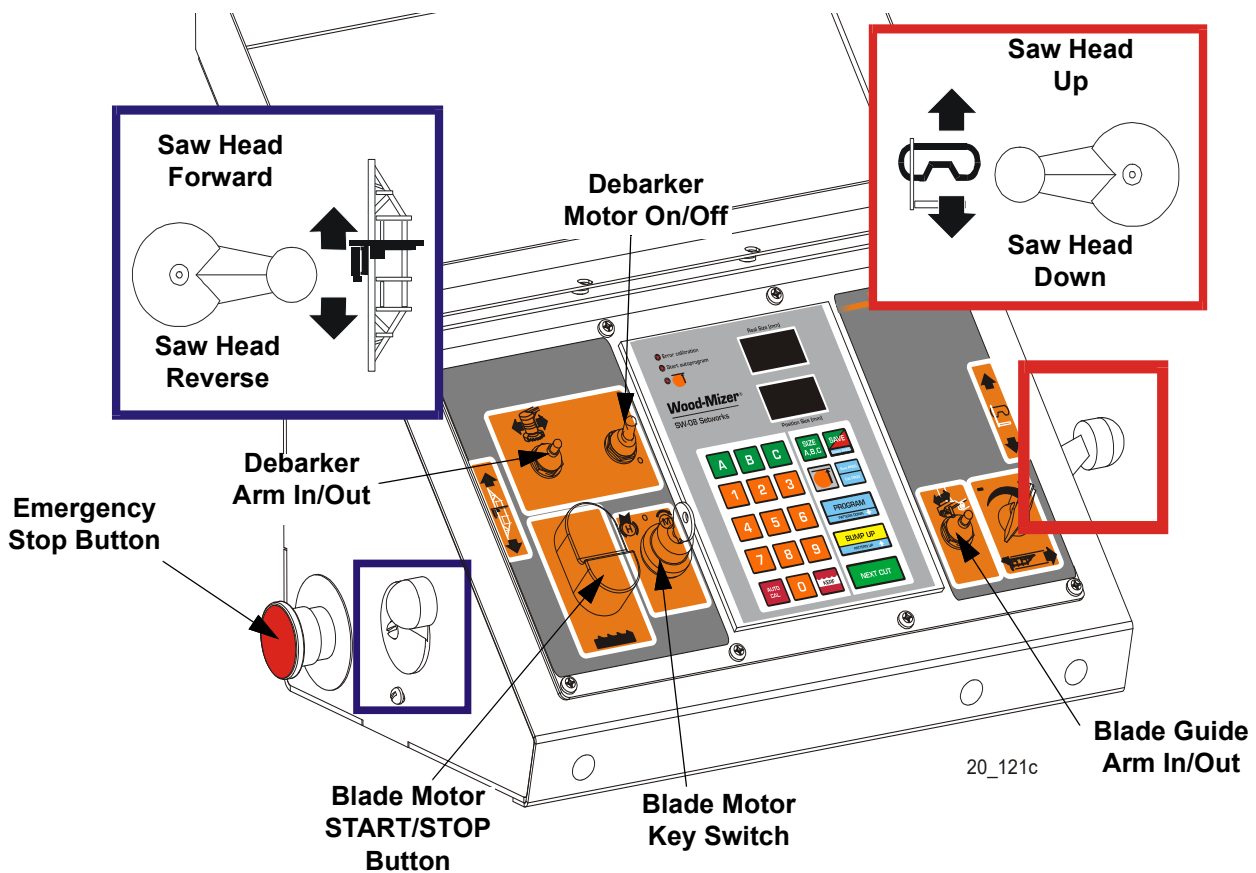

FIG. 3-11

2. Inspection of the control circuits with the E-STOP button pressed

- Turn on the blade motor;
- Press the E-STOP button located on the left side of the control box. The blade motor should be stopped.
- With the E-STOP button pressed, try to move the saw head up and down (using the switch and Setworks buttons) and forward/backward using the power feed switch. Both systems should not start.
- With the E-STOP button pressed, try to start the debarker blade motor and move the debarker arm in and out. The debarker should not work.
- With the E-STOP button pressed, try to move the blade guide arm in and out. The blade guide arm should not work.
- With the E-STOP button pressed, try to control the board return arm. The board return arm should not work.

3. Blade cover safety switches and their circuits inspection

- Turn on the blade motor;
- Open the left blade housing cover;
- The blade motor should be stopped;
- Try to start the motor. The blade motor should remain stopped;
- Close the blade housing cover;
- The blade motor should remain stopped until it is restarted with the START button.
- Turn on the blade motor;
- Open the right blade housing cover;
- The blade motor should be stopped;
- Try to start the motor. The blade motor should remain stopped;
- Close the blade housing cover;
- The blade motor should remain stopped until it is restarted with the START button.

4. Motor brake and its circuit inspection

- Turn on the blade motor. Stop the motor using STOP button. Measure the braking time.
- Turn on the blade motor. Stop the motor by switching the key to "0" position. Measure the braking time.

- Turn on the blade motor. Stop the motor by switching the key to “H” position. Measure the braking time.
- The braking time should always be shorter than 10 seconds. If the braking time is longer, it is necessary to adjust or replace the motor disk brake. See your motor option manual.

3.15 Adjusting the Air Gap of the Up/Down Motor Brake.

The air gap widens as a result of brake disc wear. The gap must not be greater than 0.5mm. The air gap must be restored to the nominal value of 0.2mm (± 0.05 mm) by tightening the adjusting screws (**A**) in the body. During the adjustment, loosen the clamping screws (**B**) and, using a feeler gauge inserted between the armature (**C**) and the body (**D**) near each adjusting screw, set the air gap to the nominal value by screwing in the adjustment screws (**A**). Tighten the clamping screws - complete tightening of the clamping node is achieved by locking the adjusting screws.

See Figure 3-12.

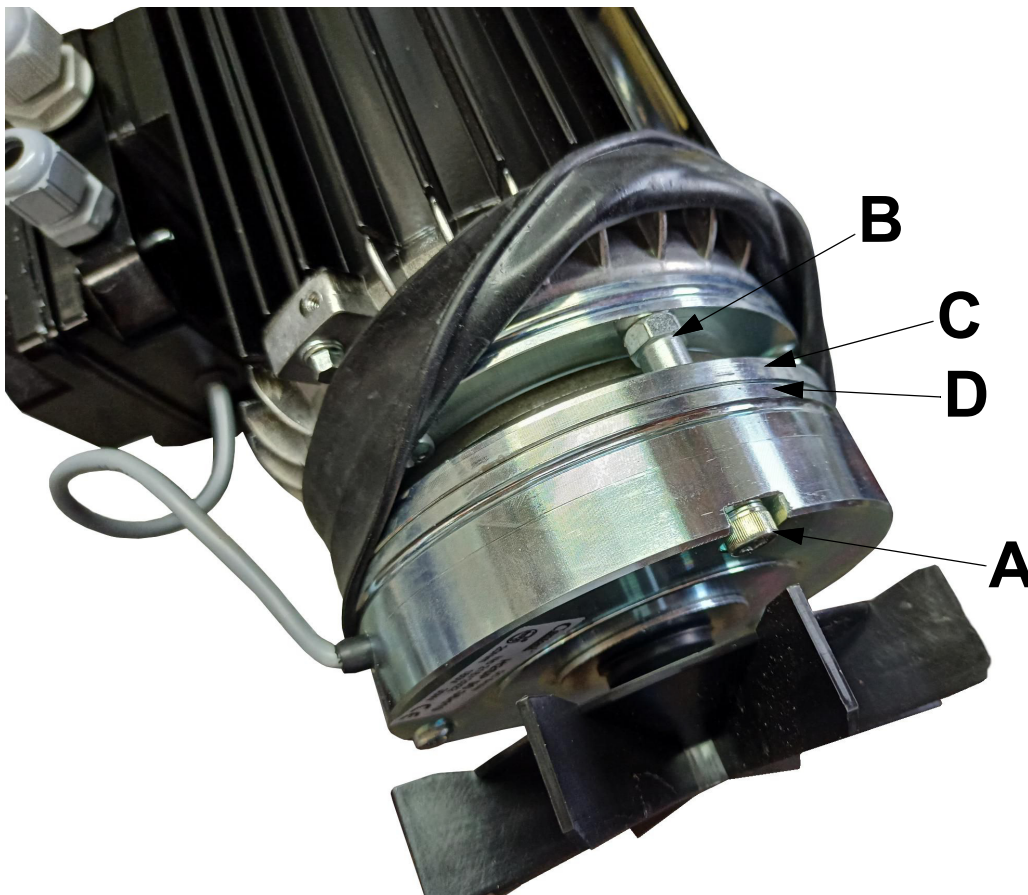

FIG. 3-12

SECTION 4 TROUBLESHOOTING GUIDE

4.1 Sawing Problems

PROBLEM	CAUSE	SOLUTION
Blades Dull Quickly	Dirty logs	Clean or debark logs, especially on entry side of the cut
	When grinding teeth, heating too much and causing teeth to soften	Grind just enough metal to restore sharpness to the teeth. Use water/coolant while sharpening blade
	Poor sharpening techniques	Make sure the tip is being sharpened completely. (See Sharpener Manual.)
Blades Break Prematurely	Rubber belts on blade wheels worn to a point that blade contacts metal pulley - look for shiny spots on edge of wheels	Change blade wheel belts (B-57)
	Poor sharpening techniques	See Sharpener Manual
	Tension too tight	Tension blade to recommended specifications
Blade Does Not Track Right on Drive Wheel	Cant adjustment is incorrect	Readjust
	Flat/worn belts	Replace B-57 belts
Blade Guides Do Not Spin While Cutting	Frozen bearings	Replace bearings
	Stiff bearings	Grease bearings
Drive Belts Wear Prematurely or Jump	Engine/motor and drive pulleys out of alignment	Align pulleys. See Section 4.5 Motor and Drive Pulleys Alignment.

PROBLEM	CAUSE	SOLUTION
Boards Thick Or Thin On Ends Or Middle Of Board.	Stress in log which causes log to not lay flat on the bed.	After log has been squared, take equal cuts off opposing sides. Take a board off the top. Turn the log 180 degrees. Take a board off. Repeat, keeping the heart in the middle of the cant, and making it your last cut.
	Set in teeth.	Resharpen and reset blade.
	Bed rails misaligned.	Realign sawmill.
Height Adjustment Jumps or Stutters When Moving Up or Down.	Mast needs lubrication.	Lubricate mast track surface.
	Up/down chain improperly adjusted.	Adjust up/down chain.
	Vertical wear pads are too tight.	Adjust pads.
	Drive belt(s) loose.	Adjust belts.
Lumber Is Not Square	Vertical side supports not square to bed	Adjust side supports.
	Blade not parallel to bed rails	Adjust bed rails parallel to blade.
	Sawdust or bark between cant and bed rails	Remove particles
	Tooth set problems	Resharpen and reset blade
Sawdust Builds Up On Track	Excessive oiling	Do not oil track
	Track wipers worn	Adjust wipers to firmly contact track
	Track is sticky	Clean track with solvent and apply silicone spray
Wavy Cuts	Excessive feed	Slow feed rate
	Improperly sharpened blade (This will be the problem 99% of the time!)	Resharpen blade (See Sharpener Manual - read entire manual!)
	Blade guides improperly adjusted	Adjust blade guides.
	Sap buildup on blade	Use Water Lube.
	Tooth set problem	Resharpen and reset blade

4.2 Electrical Problems

PROBLEM	CAUSE	SOLUTION
Up/down Excessively Slow.	Vertical wear pads too tight.	Adjust pads.
	Up/down belt loose.	Adjust belt to be as loose as possible without slipping
Up/down Or Power Feed Motors Do Not Work.	Worn/dirty contacts in drum switch.	Replace switch or remove control panel cover and clean contacts.
	Bad key switch.	Replace key switch.
	Circuit breaker.	Reset breaker in control box.
	Burned-out motor.	Replace motor.
	Bad connection on battery post or loose wire.	Check for loose wire or terminal connections.
	Up/down motor relay damaged.	Have a qualified electrician replace the relay.
	Up/down motor is damaged.	Have a qualified electrician replace the up/down motor.
	One phase lacks.	Check circuit breakers in the connectors.
	Motor thermal protector started to work.	Let the motor cool and then reset the thermal protector.
	Speed switch circuit overloaded.	Turn off the power and let the motor cool. Turn the power back on.
Power Feed Motor Does Not Work.	Power feed is overheated.	Turn off the power and let the motor cool. Turn the power back on.
	Short circuit in speed switch motor system.	Have a qualified electrician remove the short circuit.
	Sawdust buildup in the power feed pulleys.	Sawdust buildup puts mechanical bind on power feed which causes automatic motor protection circuit to activate. Remove sawdust from pulleys and operate normally. If motor does not operate after sawdust removal, reset 70 amp circuit breaker on the front of the control box.

Up/Down Or Power Feed Switches Remain Engaged When Switch Is Released.	Worn or dirty contacts in drum switch.	Manually move the power feed or up/down switch back to neutral or "off" position. Replace drum switch or remove control panel cover and clean and lubricate contacts NOTE: Use only contact grease supplied by Wood-Mizer.
	Drum switch spring broken.	Manually move the power feed or up/down switch back to neutral or "off" position. Replace drum switch spring.
Up/Down Or Power Feed Motors Overheat And Loose Power.	System overload or bind occurred.	Correct problem. See Section 4.3 Power Feed Problems. Allow motor to cool before restarting.
	Normal operation factors exceeded (eg: up/down control jockeyed excessively).	Allow motor to cool before restarting.
Everything Works And Then Cuts Out - Works Again.	Bad fuse, or ground connection.	Check and tighten connections.
Nothing Works Electrically.	Blown fuse.	Replace.
Intermittent Or Permanent Loss Of Accessory Motor Functions Occurs (Up/down, Fwd/rev, Blade Guide Functions Do Not Work).	Bad connections at accessory solenoid or bad solenoid.	Check all connections at accessory solenoid. If connections are good, replace solenoid.

4.3 Power Feed Problems

PROBLEM	CAUSE	SOLUTION
Power Feed Is Jerky At Low Speeds Or Does Not Move Until Speed Is Above Halfway Mark.	Drum switch is dirty.	Clean drum switch and lubricate with contact grease supplied by Wood-Mizer.
	Drum switch contacts are bad	Check that contacts are in good condition and positively close circuit.
	Speed switch is worn.	Replace the speed switch.
Power Feed Is Jerky, But Power Feed Motor Runs Properly At All Speeds.	Speed switch is blocked.	Turn off the power for 20 seconds and turn it back on.
	Problem is mechanical.	Refer to the Mechanical Test.
Power Feed Is Sluggish, Trips Circuit Breaker Or Current Limit.	Sawdust buildup in power feed cover.	Remove power feed belt cover and remove sawdust.

PROBLEM	CAUSE	SOLUTION
Power Feed Motor Overheats.	Middle track oiler is dragging.	Clean middle track oiler and lubricate with 30-weight oil or ATF (Automatic Transmission Fluid) such as Dexron II. Allow motor to cool before restarting.
	Ground is not level.	Level mill with carpenter's level. Allow motor to cool before restarting.
	Track roller bearing drag is excessive.	Lubricate bearings; Replace tight bearings. Allow motor to cool before restarting.
	Lower track rollers are not aligned properly.	Check stop block clearance from lower bed rail. Allow motor to cool before restarting.
	Chain is dragging.	Make sure chain is centered on cam follower bearing; Clean and lubricate chain; Adjust chain tension. Allow motor to cool before restarting.
	Chain is improperly tensioned.	Adjust chain tension. Allow motor to cool before restarting.
	Seat load is excessive.	Check seat bearings for freedom of movement; Loosen clamping screw 1/4 turn. Allow motor to cool before restarting.
	Power feed is binding.	Adjust belt tension; Check condition of belt, pulleys, bearings, and sprocket; Check motor for ground fault. Allow motor to cool before restarting.
	Saw head load is excessive.	Avoid unnecessary modifications to saw heads that would give them extra weight. Allow motor to cool before restarting.
	Blade is dull or improperly set.	Use proper blade maintenance procedures (See Sharpener or Toothsetter manual). Allow motor to cool before restarting.

4.4 Hydraulic Problems

PROBLEM	CAUSE	SOLUTION
You Can Actuate Any Hydraulic Handle, But Get No Response From The Pump.	Carriage not positioned properly to provide power to the pump	Make sure carriage contact bracket is adjusted far enough forward for battery positive contact to touch 6ft. strip on main tube. Check contact and strip for tarnish or loose wires. Clean as necessary
	Hydraulic feeder does not work	Turn on the power switch on the front side of the electric box mounted on the front side of the hydraulic box. Check whether the power is on (in position "1"). Check whether the key switch is in ACC position
		Disconnect the plug on the left side of the electric box and change the phases using a screwdriver Check whether the emergency switch is off
	One phase lacks power	Check fuses in the electric connector
	Pump motor relay damaged	Have a qualified electrician change it
	Hydraulic pump motor is overheated	Let the motor cool. When the motor is off, reset the thermal motor breaker located in the electric box mounted in the hydraulic box.
	The hydraulic feeder works despite the release of the hydraulic control lever	Standard situation. Hydraulic feeder assembly should keep working for 5-8 seconds after the hydraulic lever is released (in the neutral position)
	Poor ground connection	Check ground connection between pump and saw frame. Check contact and rail for tarnish or loose wires. Clean as necessary.
	Blown fuse	Replace
	Defective pump motor	Remove motor from pump and inspect. Repair or replace as necessary.

You Can Get Response From the Pump By Actuating All But One or Two Handles

Valve assembly switch contacts are not properly adjusted

Locate the valve switch at the bottom of the valve assembly. Use a 3MM allen wrench to loosen the set screw on each of the five switch contacts. Press each contact to the valve block and tighten the contact set screw to secure in place. **CAUTION!** Do not overtighten!

NOTE: Do not adjust the valve switch or switch spring; they have been preset at the factory.

PROBLEM	CAUSE	SOLUTION
Pump Motor Runs With Little Or No Response From The Cylinders	Low fluid level	Check fluid level. Add an all-season hydraulic fluid such as Amoco Rycon Oil MV or Mobil Multipurpose ATF (automatic transmission fluid) until level is 4 - 4 1/2" from bottom of reservoir with all cylinders retracted.
	Pressure relief valve moved from proper setting	Adjust pressure relief valve.
	Low air temperature causing fluid to thicken	Allow fluid to warm up. Synthetic fluids are available that allow for hydraulic operation in cold weather conditions (Mobil SHC 526).
Fluid Leaks From Around Cylinder Piston Ram	Worn seals	Replace seals in cylinder. Check piston ram for abrasive weld that may be causing premature seal failure.
Fluid Leak Around Pump Box	Loose seal or fitting	Wipe pump off completely to locate cause of leak. You may have to unbolt the pump to wipe behind it. NOTE: Movement of the sawmill can cause fluid to slosh up into the foam filter in the reservoir cap, and subsequently spray out, giving the appearance that fluid is leaking from the pump.

PROBLEM	CAUSE	SOLUTION
Hydraulic Side Supports Go Down Before Or At Same Time As Log Turner	Dirt in sequence valve	Remove sequence valves and clean thoroughly with kerosene. NOTE: Be sure to reassemble the valve and install it in its original position on the cylinder.
	Retainer in sequence valve worn	Replace sequence valve
	Low air temperature causing fluid to thicken	Allow fluid to warm up. Synthetic fluids are available that allow for hydraulic operation in cold weather conditions (Mobil SHC 526).
Hydraulic Turner Goes Up Before Or At Same Time As Side Supports	Spring weakening in sequence valve	Locate sequence valve at top of turner cylinder. Turn heavy spring in about 1/4 turn.
	Dirt in sequence valve	Remove sequence valves and clean thoroughly with kerosene. NOTE: Be sure to reassemble the valve and install it in its original position on the cylinder.
	Retainer in sequence valve worn	Replace sequence valve
	Low air temperature causing fluid to thicken	Allow fluid to warm up. Synthetic fluids are available that allow for hydraulic operation in cold weather conditions (Mobil SHC 526).
	Springs weakening in sequence valve.	Locate sequence valve at bottom of turner cylinder. Turn heavy spring in about 1/4 turn.

4.5 Motor and Drive Pulleys Alignment

1. Install the drive belt.
2. Use a straight edge to align the engine/motor pulley to the drive pulley. Also check that the engine pulley is within 1/8" square with the drive pulley. Loosen the engine mounting bolts and rotate the engine if necessary.
3. Check front-to-back movement of the engine does not exceed 1/4". Tighten the motor mount U-bolts if necessary.
4. Engage the clutch handle and adjust the drive belt tension to 7/16" deflection with 10 lb. of force.
5. Recheck the pulley alignment and engine squareness with the clutch handle engaged. Adjust if necessary.
6. Adjust the drive belt support to 1/4" ($\pm 1/32$) from the belt while engaged.

4.6 Power Feed Variable Speed Switch Test

With the feed rate dial switch all the way down, move the shaft of the dial back and forth to see if there is a jerky response. Turn the dial and move the shaft back and forth again. Repeat several times. If the jerkiness occurs at the same location on the dial several times, you need to replace the variable speed switch.

4.7 Power Feed Preliminary Test

This test will determine if the problem is a mechanical or electrical.

1. Remove the drive belt from the power feed drive pulley.
2. Turn the key switch to the (#2) position. Put the carriage forward/reverse switch into the forward position and turn the feed rate dial through all speeds. If the power feed motor runs properly at all speeds, the problem is a mechanical one instead of an electrical one.

4.8 Power Feed Mechanical Test

1. Remove the weight from the track rollers. They should turn smoothly and easily with very little play.
2. Make sure the middle track cover is not bent or touching the top rail.
3. Make sure the middle track oiler is free of sawdust buildup.
4. Make sure the power feed chain is not stiff from rust. Also make sure the chain is not too tight.
5. Check the power feed shaft. Visually inspect the bearings. The shaft should move neither in or out nor side to side.
6. Make sure the power feed chain cam bearing is not touching the main frame tube.

7. Make sure there is no sap or rust on the rails.
8. Make sure the block on the lower track roller assembly is not rubbing the lower rail. Also make sure the track rollers are not too tight.
9. Make sure the power feed belt is properly tightened.

SECTION 5 SAWMILL ALIGNMENT

5.1 Pre-Alignment Procedures

The Wood-Mizer sawmill is factory aligned. Two alignment procedures are available to realign the sawmill if necessary. The Routine Alignment instructions should be performed as necessary to solve sawing problems not related to blade performance. The Complete Alignment procedure should be performed approximately every 1500 hours of operation (sooner if you regularly transport the sawmill over rough terrain).

Routine Alignment Procedure:

1. Install and track the blade ([See Section 5.3](#)).
2. Check the angle of the blade in relation to the bed rails and adjust the lower track rollers if necessary ([See Section 5.18](#)).
3. Check and adjust the vertical alignment of the blade guide arm ([See Section 5.7](#)).
4. Check and adjust the horizontal alignment of the blade guide arm ([See Section 5.8](#)).
5. Check and adjust the vertical angle of the blade guides ([See Section 5.9](#)).
6. Check and adjust the horizontal angle of the blade guides ([See Section 5.11](#)).
7. Check and adjust the spacing between the blade guide flanges and the back of the blade ([See Section 5.10](#)).
8. Check and adjust the horizontal angle of the side supports ([See Section 5.13](#)).
9. Check and adjust the vertical angle of the side supports ([See Section 5.14](#)).
10. Check that the blade height scale accurately displays the actual distance from the bottom of the blade to the bed rails and adjust if necessary ([See Section 5.19](#)).

Complete Alignment Procedure:

Perform all steps in this section to completely realign the sawmill.

5.2 Frame Setup

Stationary sawmills should be setup on firm, level ground before proceeding with alignment. Shim the feet so the weight of the sawmill is evenly supported.

Portable sawmills should also be setup on firm, level ground:

LT40S AH: Adjust the two middle outriggers on the main frame tube down just enough to lift weight from the trailer tire.

LT40M AH: Adjust the two end outriggers on the main frame tube down just enough to lift weight from the trailer tire.

All Portable Sawmills: Adjust the two outer outriggers down just so they touch the ground but do not bear weight.

[See SECTION 2 Setup & Operation](#) for additional setup information.

5.3 Blade Installation And Alignment

See **Figure 5-1**. Install a blade and apply the appropriate tension ([See Section 2.8](#)). The blade tension is adjusted with the tension handle shown.

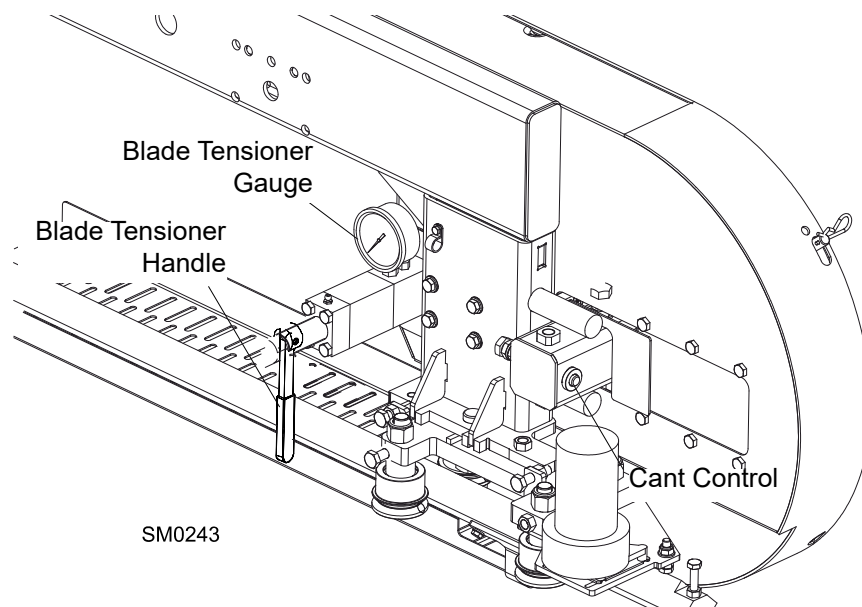

FIG. 5-1

1. Raise the middle blade housing cover and make sure all persons are clear of the open side of the saw head.
2. Turn the key switch to the position #2.
3. Manually spin the idle pulley.
4. Remove the key and check the position of the blade on the blade wheels.

Check the vertical alignment of the idle-side blade wheel. The gullet of the blade should ride the same distance from the front edge of the wheel at the top and bottom of the wheel. If it does not, loosen and tighten the appropriate adjustment screws on the wheel shaft.

See Figure 5-2. The blade wheels should be adjusted so that the gullet of 1 1/4" blades ride 3.0 mm (0.12") out from the front edge of the wheels (± 1.0 mm [0.04"]). The gullet of 1 1/2" blades should ride 4.5 mm (0.18") from the front edge of the wheels (± 1 mm [0.04"]). Do not let the teeth ride on the wheels

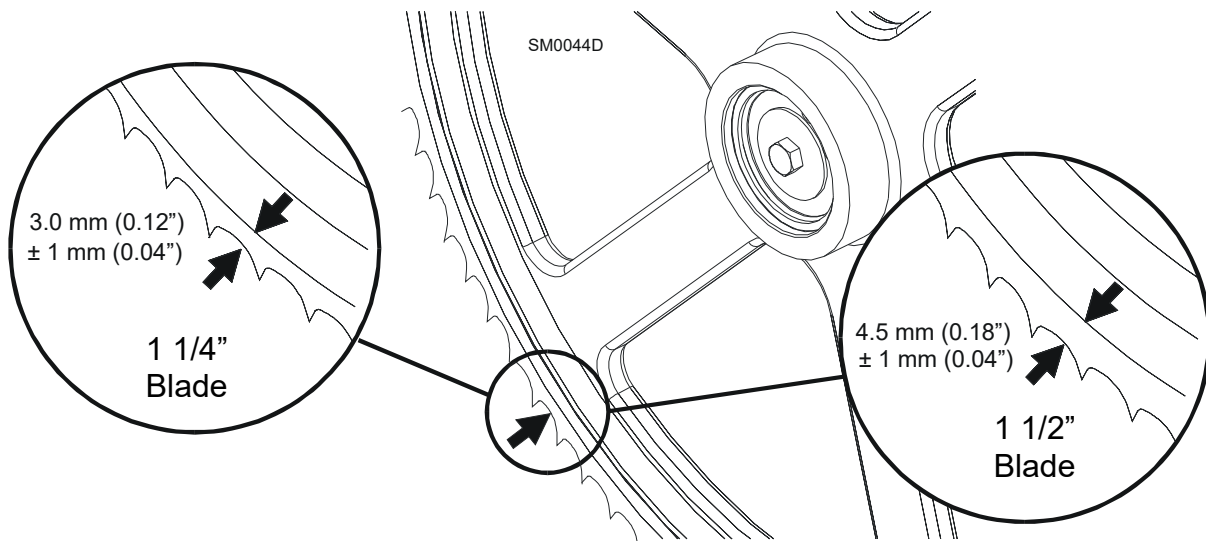

FIG. 5-2

To adjust where the blade travels on the idle-side blade wheel, use the cant control shown in **Figure 5-1**.

If the blade is too far forward on the wheels, turn the cant control counterclockwise. If it is too far back on the wheels, turn the cant control clockwise.

Some adjustment in blade tension may be needed to compensate for adjustments made with the cant control.

Adjustment with the cant control is usually all that is required to track the blade properly on both blade wheels. The drive-side blade wheel will usually not have to be adjusted. If necessary, the drive-side wheel can be adjusted as follows:

See Figure 5-3. For horizontal adjustment, use the horizontal adjustment nuts. If the blade is running too far back on the drive-side blade wheel, locate the long U-bolt on the right which mounts the bearing housing to the mounting plates. Loosen the hex nuts on the U-bolt (on the back side of the back plate). Tighten the adjustment nuts to spread the plates apart and bring the blade forward.

If the blade is running too far to the front, loosen the jam nuts on the long U-bolt and back the adjustment bolts out. Tighten the hex nuts on the long U-bolt (on the back side of the back plate).

Be sure to tighten all nuts against the mounting plates when the adjustment is complete.

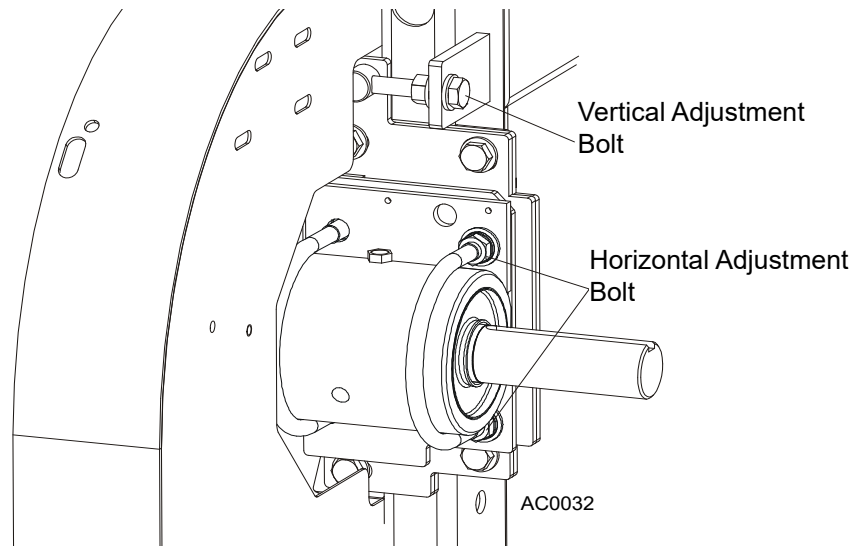

FIG. 5-3

The vertical angle of the drive side wheel is factory-set and should not need to be adjusted. If adjustment is needed, use the vertical adjustment bolt. To tilt the wheel upward, loosen the jam nut and turn the vertical adjustment bolt clockwise. To tilt the wheel downward, loosen the jam nut and turn the vertical adjustment bolt counterclockwise. Be sure to tighten the jam nut.

5.4 Saw Head Slide Pad Adjustment

There are eight nylon pads positioned between the saw head frame and vertical mast. The spacing of the pads is factory set and rarely needs adjusting. To check the pad spacing, perform the following steps.

NOTE: The pads on the engine side of the mast are referred to as the "inner" pads. The pads on the control side of the mast are referred to as the "outer" pads.

NOTE: Shims are often used around the clamping bolts, between the C-frame support bracket and the mast v-brace (C). The shims align the v-brace (C) to the mast so that the entire face of each slide pad makes contact with the mast. Be sure to keep these shims in place when performing the following adjustment.

See Figure 5-4.

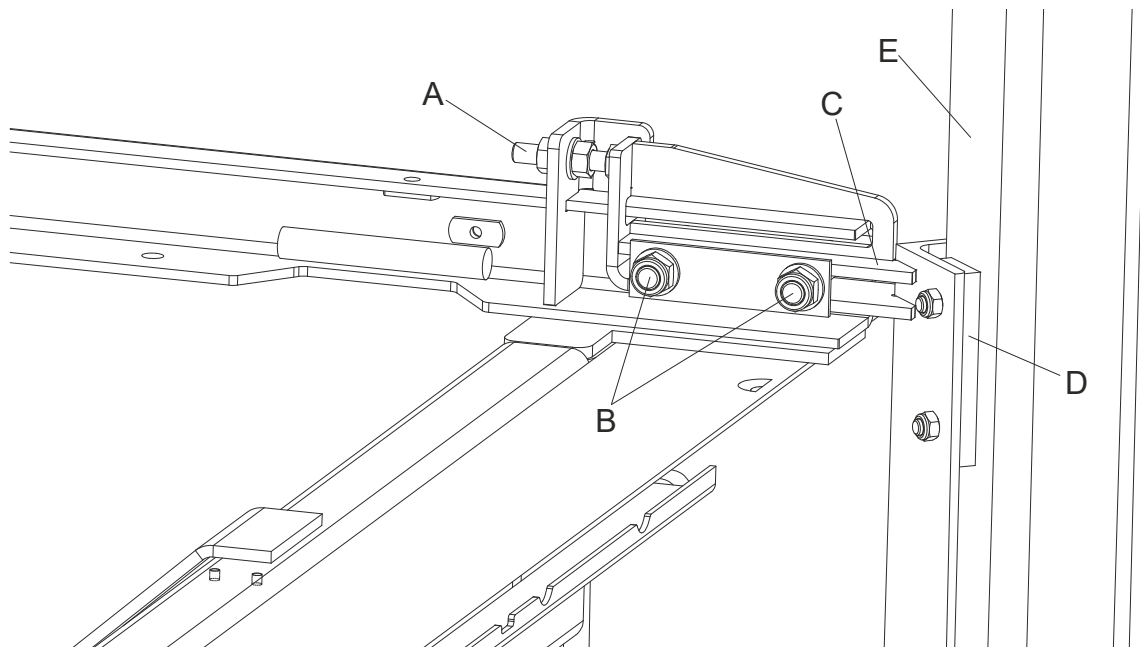

FIG. 5-4

1. Raise the saw head to the top of the vertical mast and secure the saw head with a chain at the top, or shim it underneath. Check the top set of four pads (D). The outer two pads should be touching the mast rails (E). There should be a small gap (about 0,2mm wide) between one of the inner pads and the mast rail.



WARNING! Always secure the cutting head with a chain or a brace before adjusting the mast pads. The cutting head may fall, causing severe injury or death.

2. To adjust the spacing of the upper set of pads, lower the saw head until you can access the upper slide pad adjustment bolts (D).
3. Loosen the upper locking bolts (B) and turn the adjusting bolt (A) as necessary to provide the pad spacing described in Step 1.

4. Lower the saw head to the bottom of the vertical mast. Check the bottom set of four pads (D).

There should be a small gap between one of the outer pads and the mast rail (E). The gap should be about 0,2mm wide. The inner two pads should be touching the mast rails (E). To adjust the spacing of the lower set of pads, raise the saw head until you can access the lower slide pad adjustment bolts.

5. Loosen the lower locking bolts and turn the adjusting bolt as necessary to provide the pad spacing described in Step 4.



CAUTION! Due to variations in the vertical mast, the pad spacing may vary throughout the travel of the saw head. Check the pad spacing at the top and bottom ends of the mast only. Pads adjusted too tight will cause premature up/down motor failure.

5.5 Adjusting The Lower Track Rollers

See Figure 5-5. Making these adjustments correctly will give you square cuts and accurate dimensions across the width of your boards.

1. Using the feed controls, move the saw carriage so that the blade is positioned over the front pivot end rail.
2. Check the lower roller on the bottom track rail. Make sure that the bottom rollers touch the bottom rail but remain loose enough that you can turn them with your finger. Use the vertical bolts to adjust the bottom track rollers.
3. Check the inside lower rollers. Both inside rollers should touch the rail so that you cannot spin them by hand. If the rollers are not adjusted evenly and you can spin either one, adjust the horizontal nuts until the roller cannot be spun by hand. Check the other roller and adjust if necessary. Adjust both inside rollers until each evenly supports the carriage and you cannot spin either by hand.
4. Move the carriage forward until the blade is positioned over the rear pivot end rail. Repeat steps 2 & 3 until all lower rollers are adjusted properly at the front and rear of the sawmill.

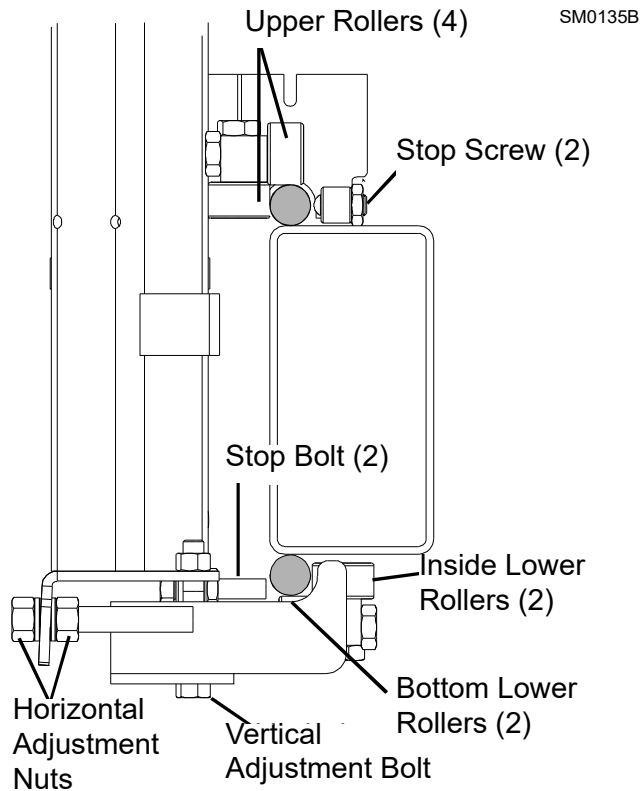

FIG. 5-5

5. Remove the blade guides, or adjust them so that they do not touch the blade.
6. Open the adjustable blade guide arm to within 1/2" (15 mm) of full open.
7. Move the carriage back to the front pivot end rail. Raise the cutting head until the bottom of the blade is 17" (400 mm) above the outside of the pivot rail support by actual measurement with a tape or ruler.

See Figure 5-6.

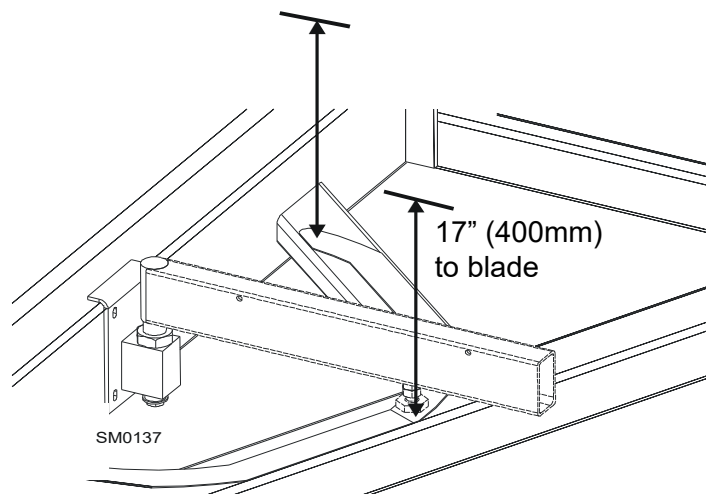

FIG. 5-6

8. Move the carriage forward to check the distance to the blade at the inside of the pivot rail support. All measurements should be equal within ± 1.0 mm.
9. Turn the horizontal adjustment nuts evenly to adjust the inner lower rollers to tilt the saw head until the blade is parallel (± 1.0 mm) to the pivot rail support on the outside.

NOTE: Adjustments of the lower track rollers change the angle between the cutting head and sawmill bed rails. Only small adjustments of the lower track rollers should ever be needed.

10. After the lower track rollers are adjusted properly, adjust the upper and lower stop screws. Tighten each screw until it just touches the rail. Then, back the screw off 1/2 turn. The gap will be approximately 2.0 mm.



CAUTION! It is important that the lower stop bolts are properly adjusted to secure the carriage on the track rail. Failure to properly adjust the stop bolts can cause saw head damage, especially during mill transportation.

5.6 Adjusting Bed Rails To The Blade

1. Move the vertical clamp to its lowest position. Before using the clamp tube as a reference to set the blade, make sure it is level.
2. Move the clamp all the way toward the clamp stop. Position the saw head so the blade is over the clamp tube. Measure from the outer end of the clamp tube to the bottom of the blade.
3. Move the saw head back to power the hydraulics and move the clamp all the way out. Position the blade over the clamp tube again and measure from the inner end of the clamp tube to the bottom of the blade.
4. If the clamp tube is level, the measurement to the blade at both ends will be the same within 1/16" (1.5 mm). If adjustment is needed, loosen the four mounting bolts at the outer end of the clamp tube and adjust the clamp tube up or down as necessary. Tighten the mounting bolts.

See Figure 5-7.

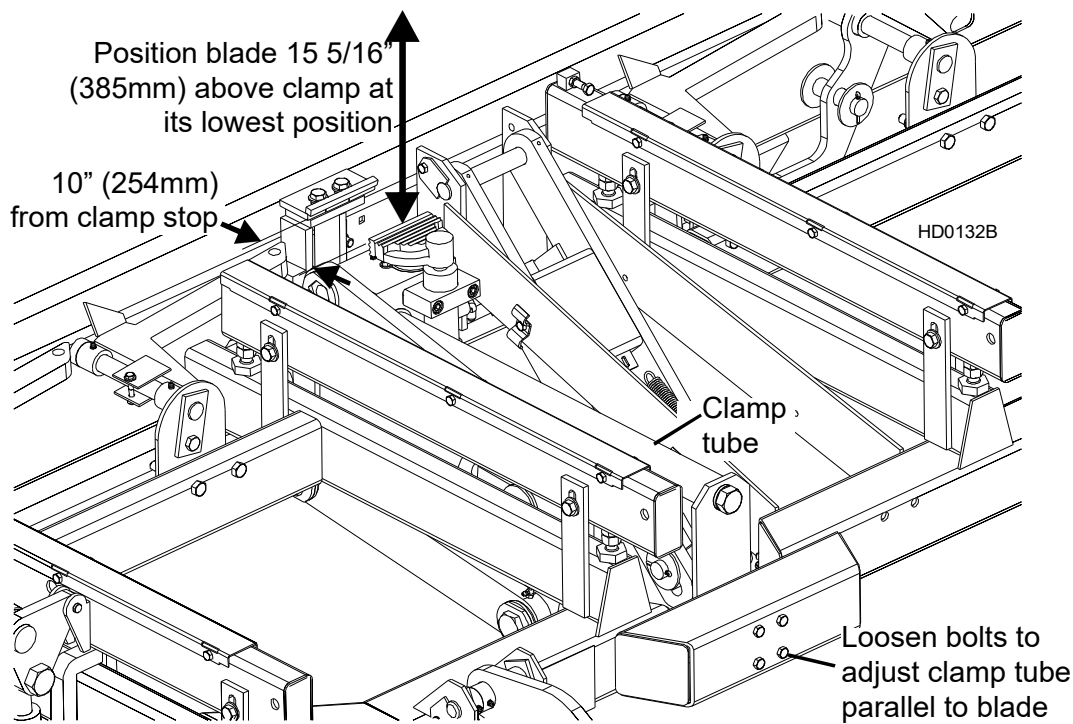

FIG. 5-7

5. Move the saw head back to power the hydraulics and move the clamp so it is 10" from the clamp stop. Move the saw head forward until it is positioned over the clamp. Raise the saw head until the blade measures 15 5/16" (385 mm) from the clamp at its lowest position.
6. Adjust the front pivot rail 90° to the main bed tube.
7. Move the saw head to center the blade over the front pivot bed rail.
8. Measure the distance from the top of the pivot rail to the bottom of the blade. Make this measure-

ment at each end of the pivot rail.

9. The two measurements should be 15" (375 mm).
10. Loosen the locking set screws and turn the inner height adjustment nut to adjust the height of the inner end of the pivot rail.

See Figure 5-8.

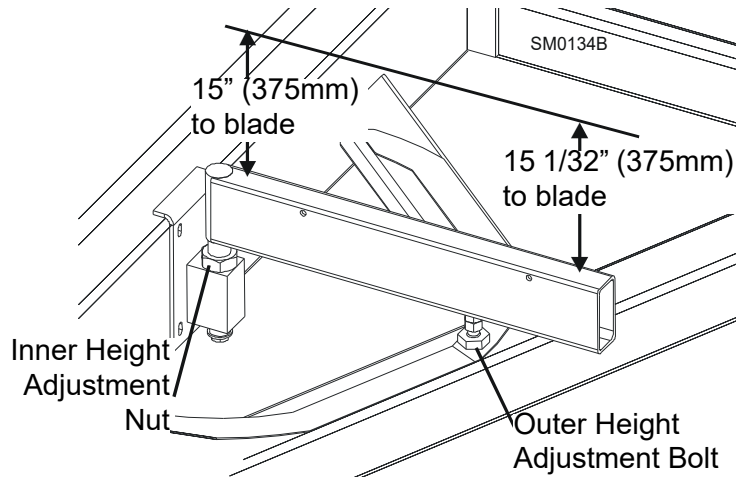

FIG. 5-8

See Figure 5-9. Optional bed rail (angled)

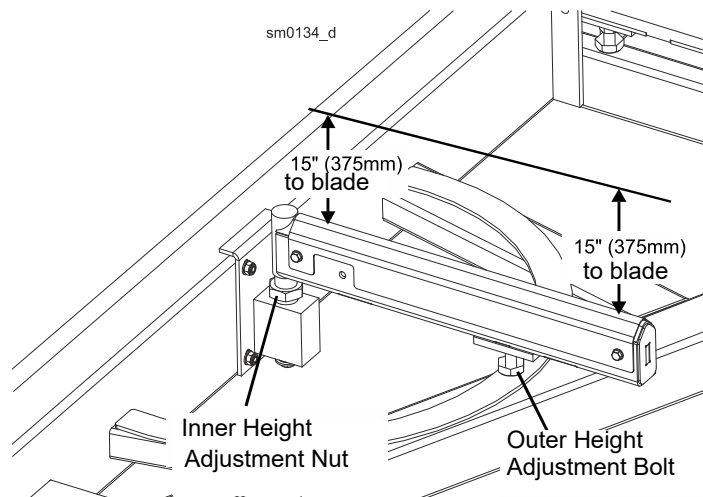

FIG. 5-9

11. Loosen the jam nut and turn the outer adjustment bolt to adjust the height of the outer end of the pivot rail.
12. Move the saw head so the blade is positioned over the center of the front main bed rail.

- 13.** Measure the distance between the bottom of the blade and the bed rail at each end of the bed rail. The bed rail should measure 15" (375 mm) (+ 1.0 mm on the outer end) from the blade at each end of the rail.

See Figure 5-10.

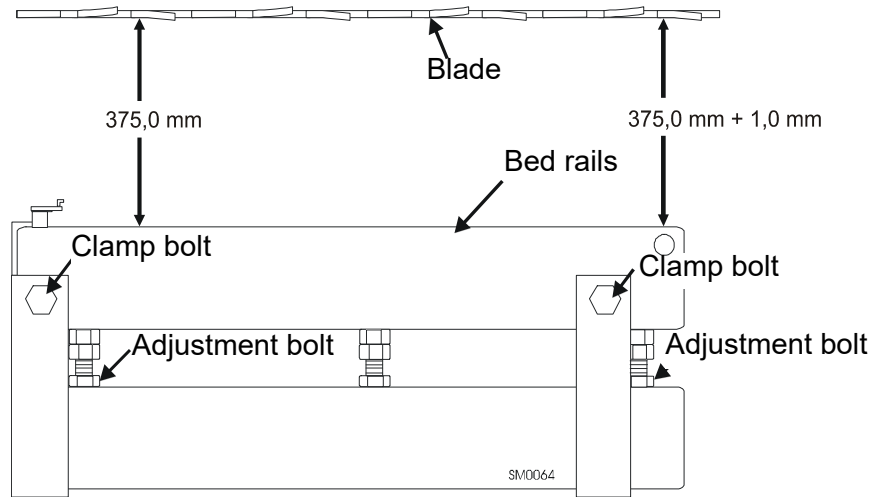

FIG. 5-10

See Figure 5-11. *Optional bed rail (angled)*

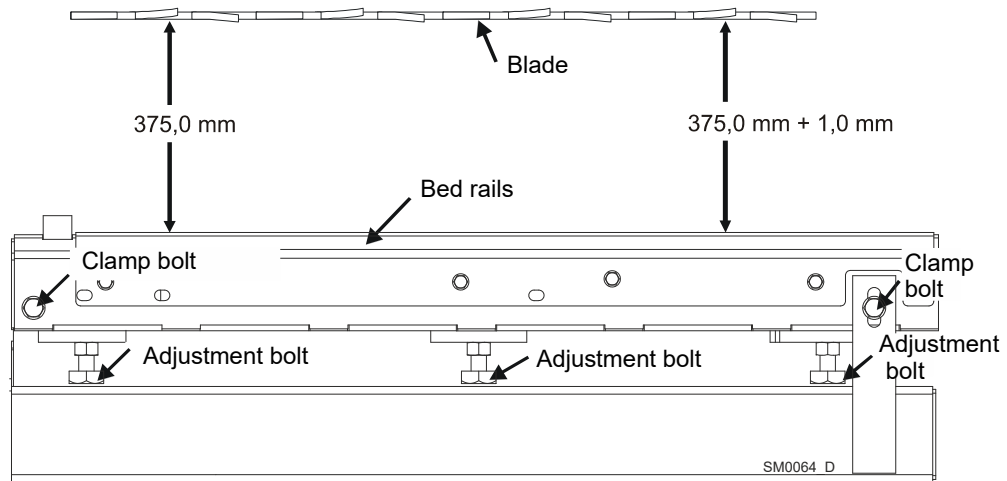

FIG. 5-11

- 14.** Loosen the bed rail clamping bolts and turn the adjustment bolts to move the bed rails to the blade if necessary.
- 15.** Retighten the clamping bolts and adjustment bolts.
- 16.** Without adjusting the saw head height, check the three remaining main bed rails and the rear pivot rail. Adjust them so that all measure the same distance from the blade at both ends of the bed rail.

5.7 Blade Guide Arm Alignment

Each Wood-Mizer sawmill has two blade guide assemblies that help the blade maintain a straight cut. The two blade guide assemblies are positioned on the saw head to guide the blade on each side of the material being cut.

One blade guide assembly is mounted in a stationary position on the drive side of the saw head. This assembly is referred to as the "inner" blade guide assembly.

The other blade guide assembly is mounted on the idle side of the saw head. It is referred to as the "outer" assembly and is adjustable for various widths of materials to be processed.

Blade guide alignment includes four steps:

- Blade Deflection
- Blade Guide Vertical Tilt
- Blade Guide Flange Spacing
- Blade Guide Horizontal Tilt

Perform the blade guide alignment after you have aligned the blade on the wheels and adjusted the blade and blade guide arm parallel to the bed rails. After blade guide alignment, check the scale indicator to make sure it is adjusted properly.

NOTE: During blade guide alignment, remove the blade guide adjusting screws and apply a lubricating oil such as 10W30 or Dexron III to each screw. This will prevent the screws and threaded holes from corroding and make screw adjustments easier.

1. Adjust the blade guide arm in to 1/2" (15 mm) from fully closed.
2. Manually try to move the arm up and down. If you can move the arm by hand, you will need to tighten the arm rollers.

See Figure 5-12. Loosen the jam nuts and turn the adjustment bolts in to tighten the blade guide arm rollers. Retighten the jam nuts.

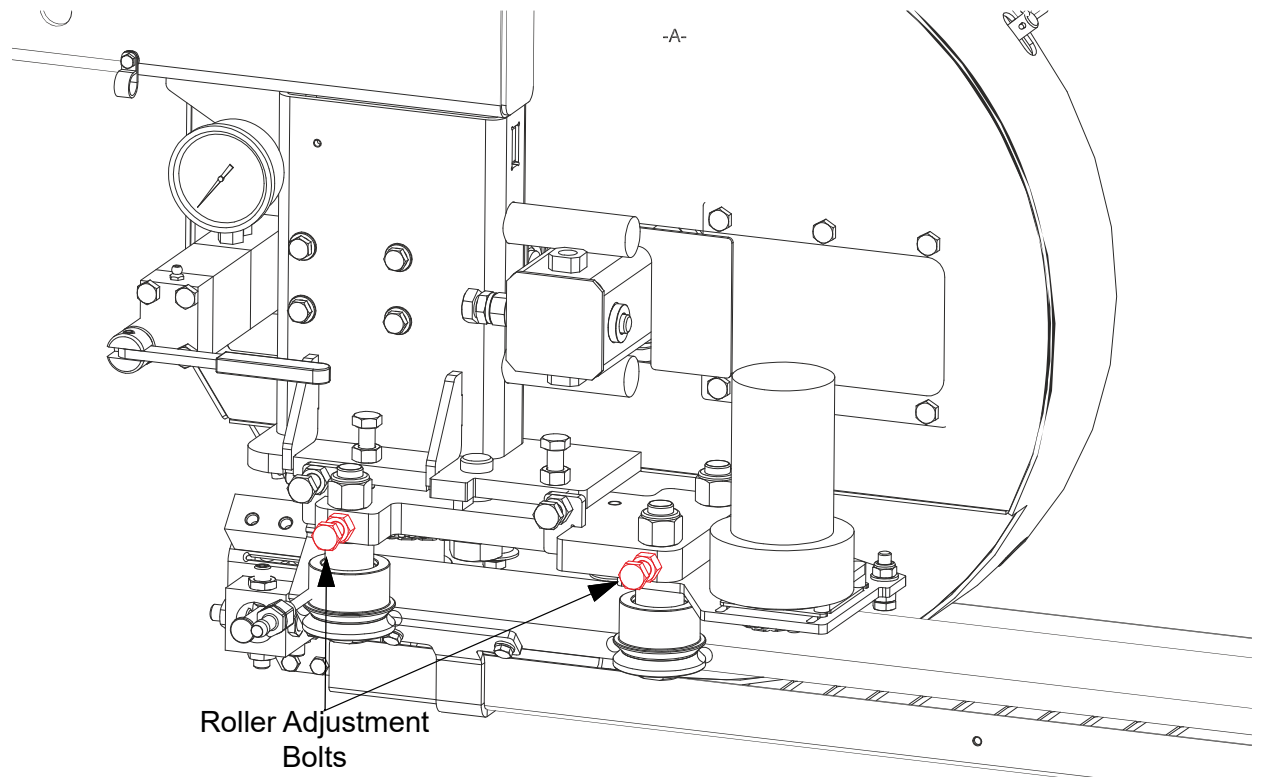

FIG. 5-12

After tightening the blade guide arm rollers, check that the arm is aligned properly.

3. With the arm adjusted 1/2" (15 mm) from fully closed, measure the distance between the rear blade guide roller and the back of the blade.

See Figure 5-13.

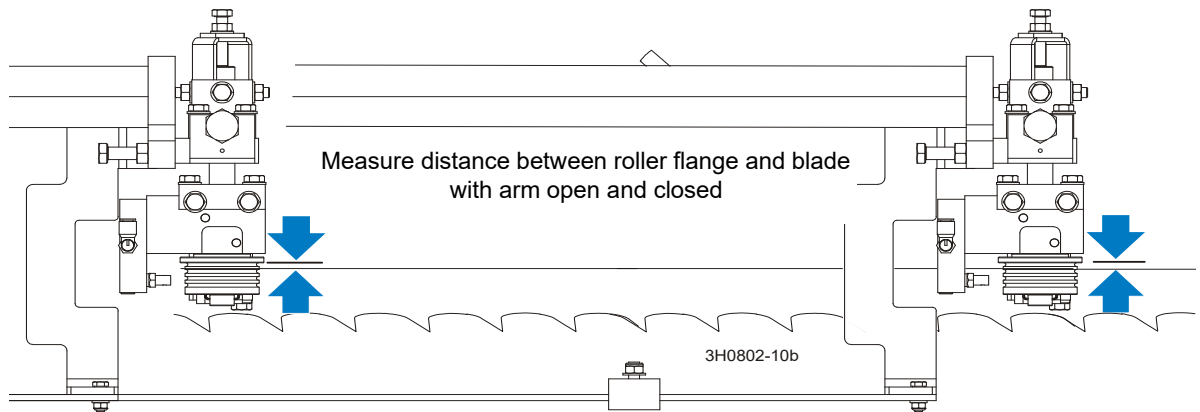

FIG. 5-13

4. Adjust the blade guide arm to 1/2" (15 mm) from fully open and remeasure the distance from the roller flange to the back of the blade. The two measurements should be the same. If not, adjust the outer rollers in or out to tilt the arm horizontally.

See Figure 5-14. Loosen the horizontal adjustment bolt jam nuts. To tilt the arm in toward the blade, loosen the right bolt and tighten the left bolt. To tilt the arm out away from the blade, loosen the left bolt and tighten the right bolt. Retighten the jam nuts and recheck the blade guide arm horizontal tilt.

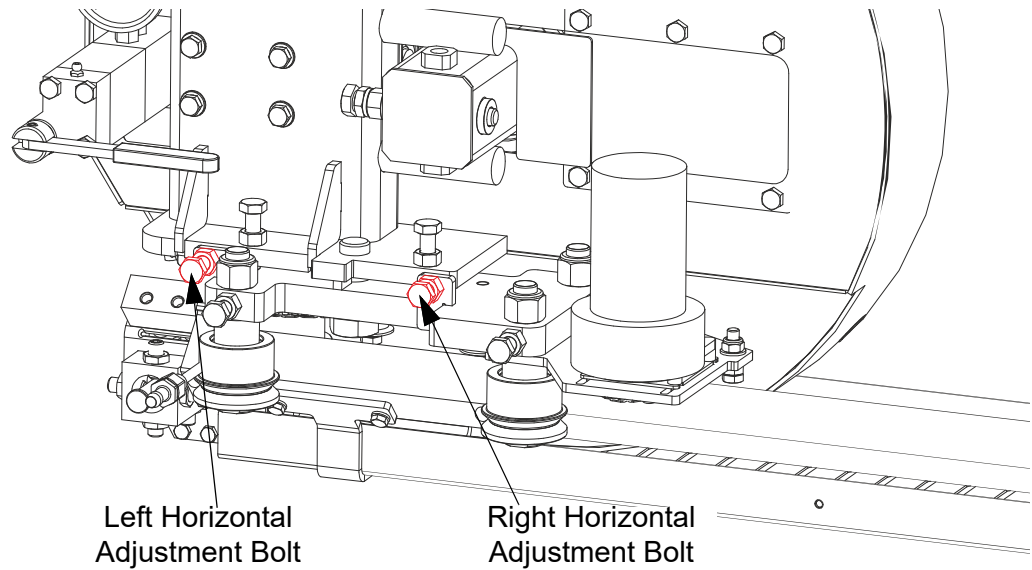

FIG. 5-14

5. Now check the vertical tilt of the blade guide arm. Move the saw head so the blade guide arm is positioned over a bed rail.
6. With the arm 1/2" (15 mm) from fully closed, raise or lower the saw head until the bottom of the blade guide block is 15" (375 mm) from the top of the bed rail (dimension A).

See Figure 5-15.

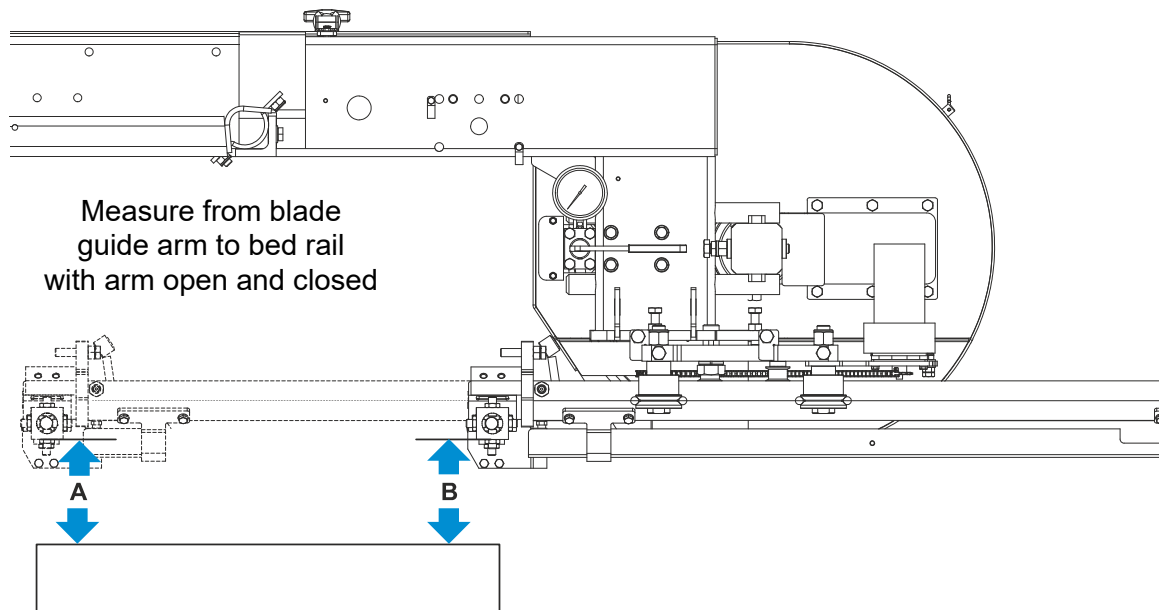

FIG. 5-15

7. Adjust the blade guide arm to 1/2" (15 mm) from fully open. Measure the distance from the bottom of the blade guide mounting block to the bed rail. This measurement should be 15", 375 mm (dimension B) or slightly higher because the saw head is tilted up 1/26" (1 mm) on the outside ([See 5.18 Saw Head Tilt](#)). If the measurement is different, adjust the blade guide arm vertically.

See Figure 5-16. Loosen the vertical adjustment bolt jam nuts. To tilt the blade guide arm down, loosen the right bolt and tighten the left bolt. To tilt the blade guide arm up, loosen the left bolt and tighten the right bolt. Retighten the jam nuts and recheck the blade guide arm vertical tilt.

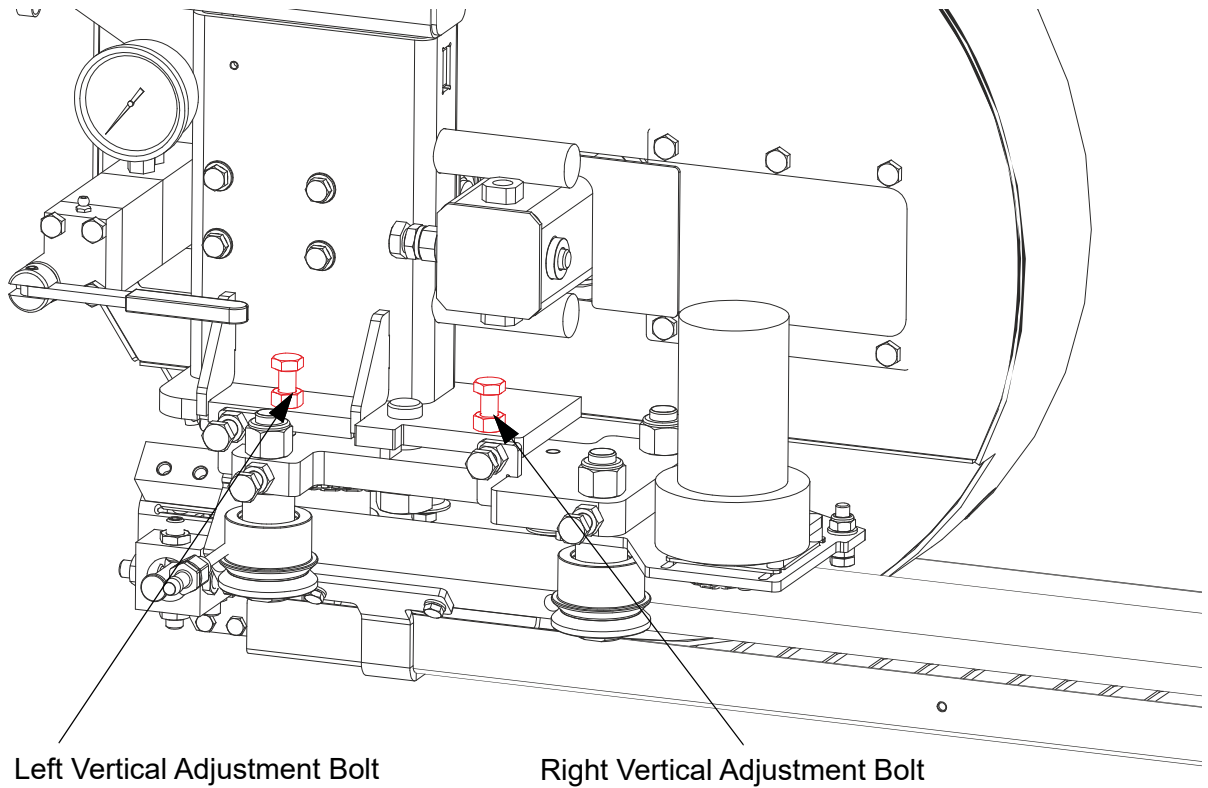

FIG. 5-16

5.8 Blade Deflection

Perform the following steps to achieve proper blade deflection with the blade guides.

1. Raise the carriage until the blade is 15" (375 mm) above a bed rail. Measure the actual distance with a tape from the top of the rail to the bottom of the blade.
2. Install the blade guides. Make sure the two set screws shown are threaded into the blade guide shaft until they touch each other.

See Figure 5-17.

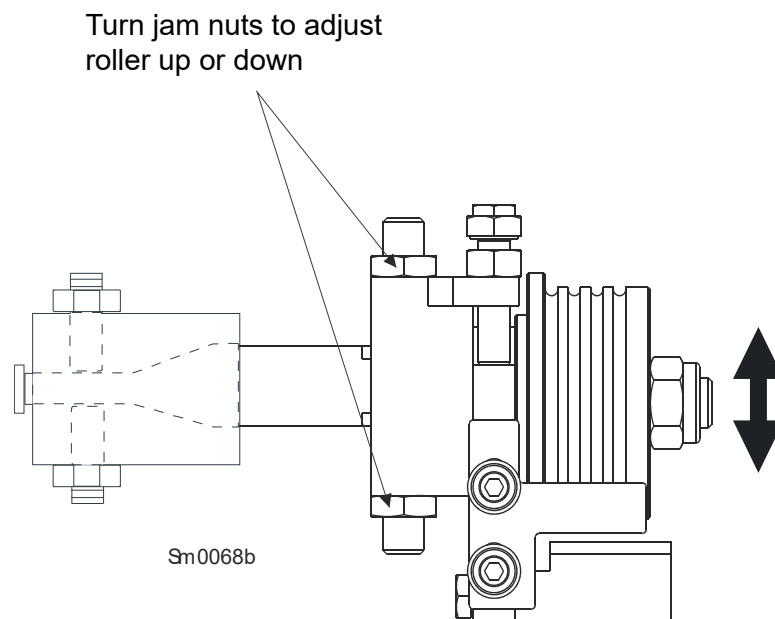

FIG. 5-17

3. Loosen the bottom jam nut and tighten the top jam nut until the blade guide deflects the blade down 4.0 mm.
4. Repeat for the other blade guide.

NOTE: Be sure that the blade guide deflector rod clears the blade on both guide assemblies. The rod on the outer guide assembly should be checked with the arm all the way in and all the way out.

5.9 Blade Guide Vertical Tilt Adjustment

Check that the blade guide does not tilt the blade up or down. A Blade Guide Alignment Tool (BGAT) is provided to help you measure the vertical tilt of the blade.

1. Open the adjustable blade guide arm 1/2" (15 mm) from full open.
2. Clamp the alignment tool on the blade. Position the tool close to a blade guide roller. Be sure the tool does not rest on a tooth or burr, and is lying flat on the blade.

See Figure 5-18.

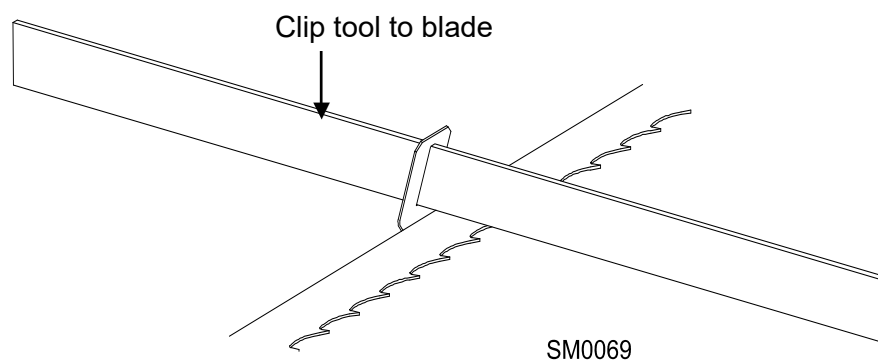

FIG. 5-18

3. Measure the distance from the bed rail to the bottom of the tool.

NOTE: If the sawmill is equipped with stainless steel bed rail covers, be sure to measure from the blade guide alignment tool to the top surface of the cover rather than the bed rail tube.

4. Move the carriage so that the front end of the tool is positioned above the bed rail.
5. Measure the distance from the bed rail to the bottom edge of the tool.
6. Loosen one set screw at the side of the blade guide assembly.
7. Use the set screws shown to tilt the blade guide until the measurement from the bed rail to the tool equals the first measurement taken at the center of the tool.

See Figure 5-19.

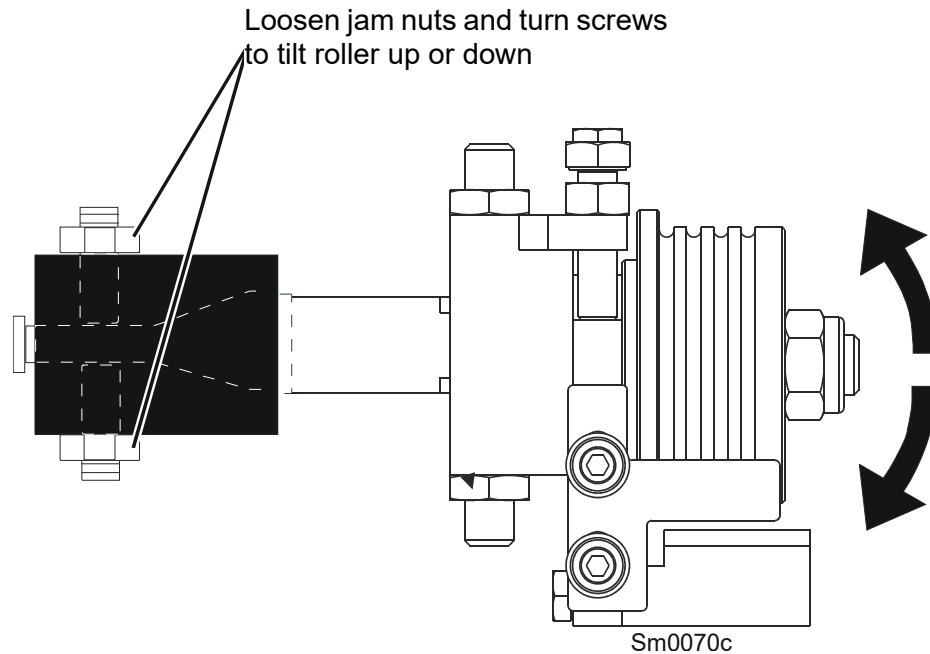

FIG. 5-19

8. Move the carriage forward so the back end of the tool is over the bed rail.
9. Use the set screws shown to adjust the blade guide tilt until the measurement from the bed rail to the tool equals the other two measurements taken.
10. Move the tool close to the other blade guide and repeat the previous steps.

NOTE: If major adjustments to blade guide tilt were made, measure the distance between the blade and the bed rails again to ensure the correct 4.0 mm blade guide deflection. Adjust if necessary.

5.10 Blade Guide Spacing

HINT: When adjusting blade guide spacing, loosen the top set screw and one side set screw only. This will ensure horizontal and vertical tilt adjustments are maintained when the set screws are retightened.

1. Adjust the inner blade guide so the blade guide flange is approximately 3.0 mm from the back of the blade.
2. Loosen one side and one top set screw shown. Tap the blade guide forward or backward until properly positioned.

See Figure 5-20.

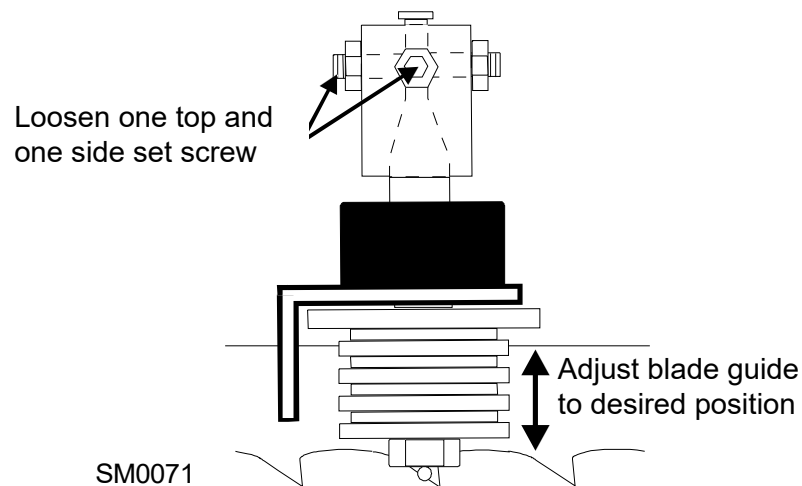

FIG. 5-20

3. Retighten the two set screws.
4. Adjust the outer blade guide in the same way so the blade guide flange is approximately 3.0 mm from the back of the blade.

5.11 Horizontal Tilt Adjustment

1. Finally, both blade guides must be tilted horizontally. Adjust the blade guide arm halfway in.

See Figure 5-21.

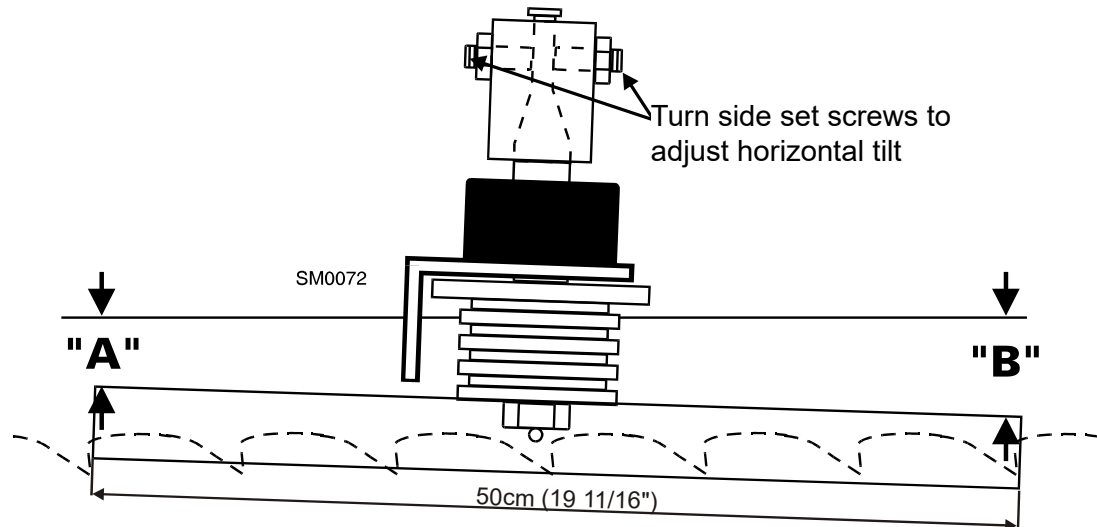

FIG. 5-21

2. Place the Blade Guide Alignment Tool against the face of the outer blade guide roller.
3. Center the tool on the roller and measure between the back edge of the blade and the ruler at the end closest to the inner blade guide ("B").
4. Measure between the back edge of the blade and the other end of the ruler ("A").
5. The roller should be tilted slightly to the left ($A=B-1.4$ " [6 mm]).
6. Use the side set screws to adjust the horizontal tilt of the roller.
7. Repeat steps 3-7 for the inner blade guide roller.

NOTE: Once the blade guides have been adjusted, any cutting variances are most likely caused by the blade. See the **Blade Handbook, Form #600**.

5.12 Blade Guide Disc Adjustment

To ensure correct cutting, adjust the gap between the blade guide disc and the blade. Perform the adjustment with the blade installed and properly tensioned.

See Figure 5-22. Loosen both nuts and retaining bolts. Use the adjustment bolt to raise or lower the disc until its distance from the blade is 0.3 - 0.5 mm. Then retighten the retaining bolts so that the disc is parallel to the blade. Retighten the retaining bolt nuts.

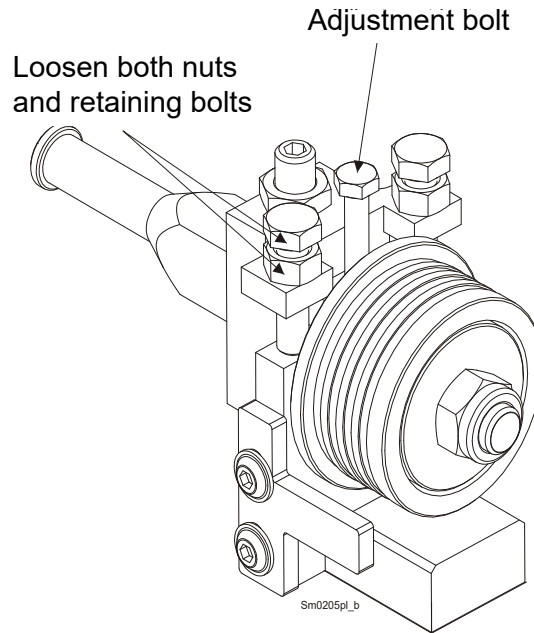

FIG. 5-22

See Figure 5-23. The gap between the disc and the blade should measure 0.3 - 0.5 mm.

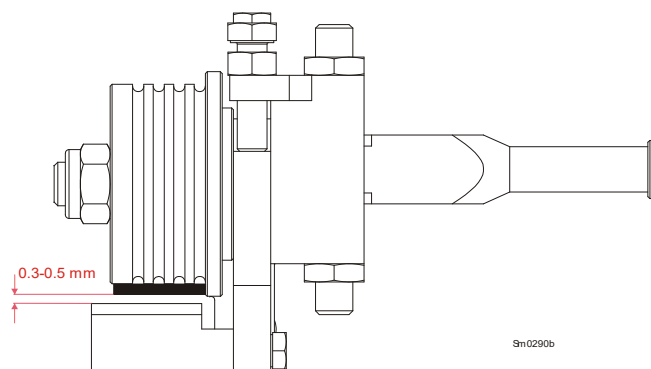

FIG. 5-23

5.13 Horizontal Adjustment of Side Supports

Logs and boards are clamped against the side supports when sawing. The side supports must be square to the bed to ensure square lumber.

1. Swing the side support down.
2. Measure between the face of the support and the main bed tube. Make measurements at both ends of the side support to make sure that it is parallel to the rail.

See Figure 5-24.

3. Use the two lower bolts to adjust the side support so $B=A$.
4. Repeat for remaining side supports.

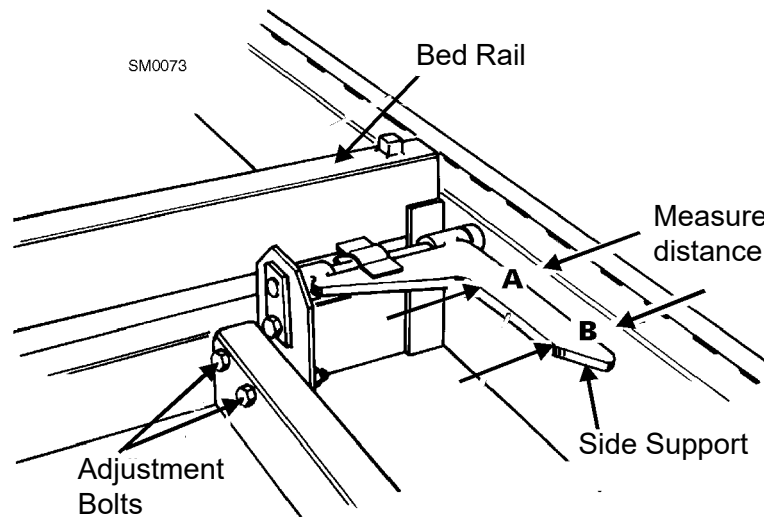

FIG. 5-24

5.14 Vertical Adjustment of Side Supports

1. Place a flat board across the bed rails.
2. Swing a side support up so that it is vertical.
3. Pull back at the top of the support to eliminate slack as if a log were being clamped against it.

See Figure 5-25.

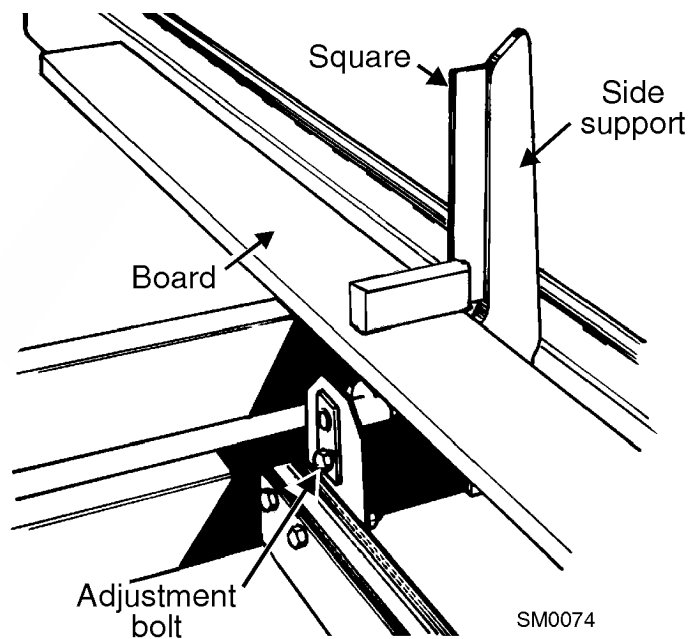

FIG. 5-25

4. Check the angle of each support with a square on the board.
5. The side support should be 90° to the bed rails. Loosen the top adjustment bolt, adjust the side support, and retighten the bolt.
6. Repeat for the remaining side supports.

5.15 Vertical Adjustment of Side Supports¹

1. Place a flat board on the bed rails, parallel to the main bed rail.
2. Swing the side support down.
3. Pull back at the top of the support to eliminate slack as if a log were being clamped against it.

See Figure 5-26.

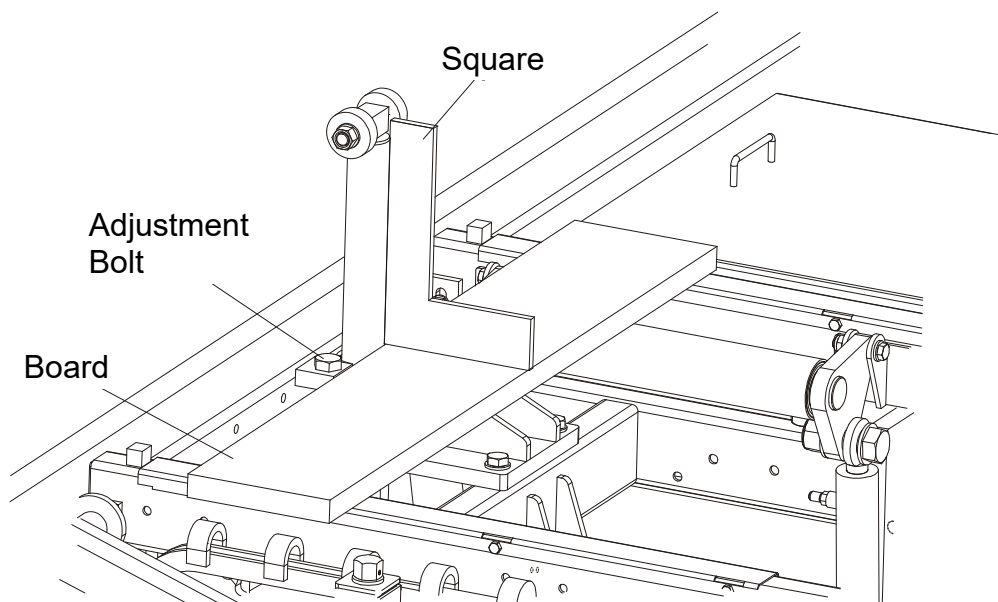

FIG. 5-26

4. Check the angle of each support with a square on the board.
5. The side support should be 90° to the bed rails. If not, loosen the top adjustment bolt, adjust the side support, and retighten the bolt.
6. Repeat for the remaining side supports.

1. 519730 Side Supports - New M-type Frame, Mobile Sawmills (AHP/DHP Hydraulics)

5.16 Clamp Stop/Stop Bolt Adjustment

1. Once the side supports are aligned, pivot them down to their horizontal position.
2. Tie a string across the face of the side supports.

See Figure 5-27.

3. Loosen the clamp stop bolts and adjust the clamp stop until it touches the string. Loosen the jam nut and adjust the bolt on the middle-rear bed rail until it touches the string.

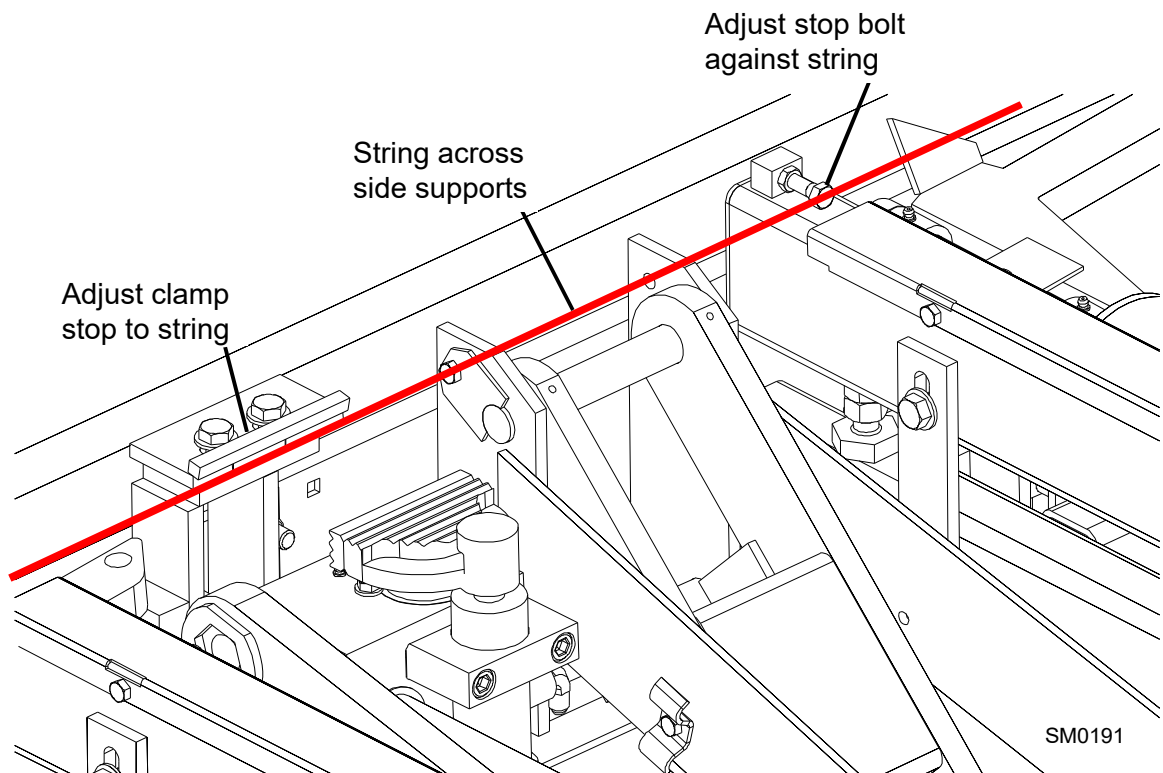

FIG. 5-27

5.17 Vertical Adjustment of Side Supports (Super Hydraulic Sawmill Only)

1. Place a flat board on the bed rails.
2. Swing a side support up so that it is vertical.
3. Pull back at the top of the support to eliminate slack as if a log were being clamped against it.

See Figure 5-28.

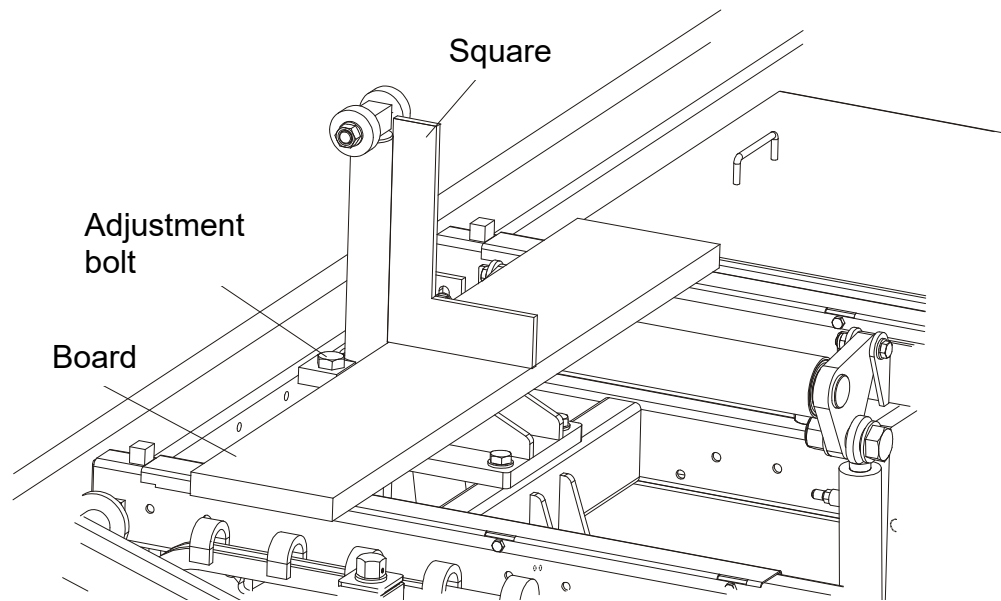

FIG. 5-28

4. Check the angle of each support with a square on the board.
5. The side support should be 90° to the bed rails. Loosen the top adjustment bolt, adjust the side support, and retighten the bolt.
6. Repeat for the remaining side supports.

5.18 Saw Head Tilt

As the blade enters a wide log or cant, the outside of the saw head will drop down slightly. To compensate for the drop, use the lower track roller horizontal bolts to raise the outside of the saw head 1/16" (1.5 mm).

1. Move the saw head so the blade is positioned 14 3/4" (375 mm) above a bed rail.
2. Adjust the lower track roller horizontal nuts until the blade measures 14 13/16" (376 mm) from the bed rail near the outer blade guide.

See Figure 5-29.

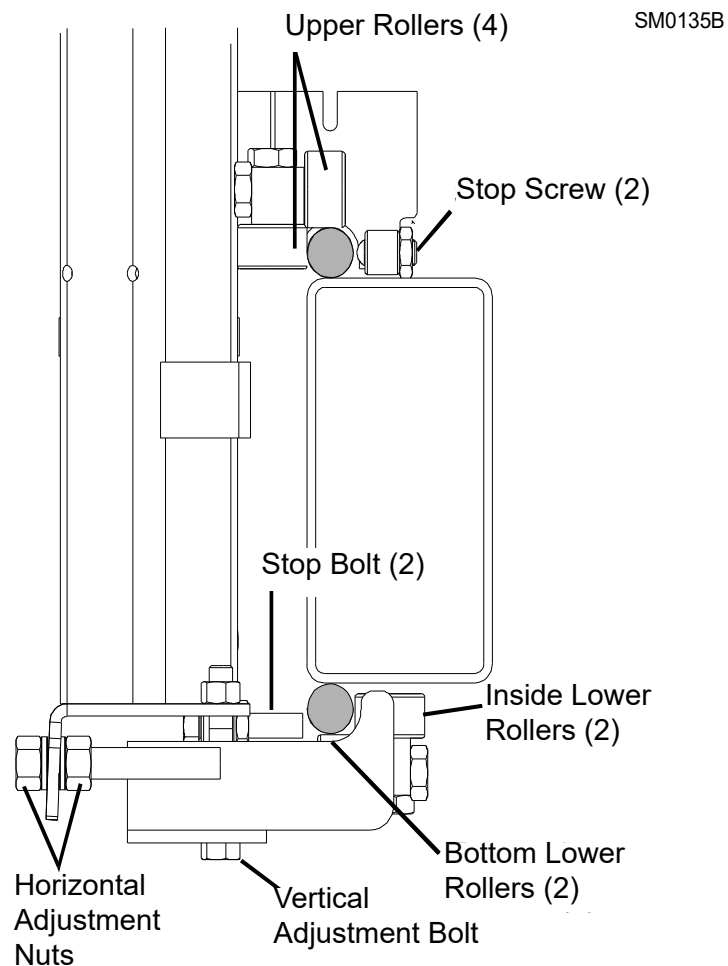

FIG. 5-29

5.19 Blade Height Scale Adjustment

After the entire sawmill has been aligned and all adjustments made, check that the blade height scale indicates the true distance from the blade to the bed rails.

1. Move the saw head so the blade is positioned directly above one of the bed rails. Measure from the bottom edge on a down-set tooth of the blade to the top of the bed rail (or stainless steel sleeve if applicable).

See Figure 5-30.

2. View the blade height scale with eyes level with the indicator.

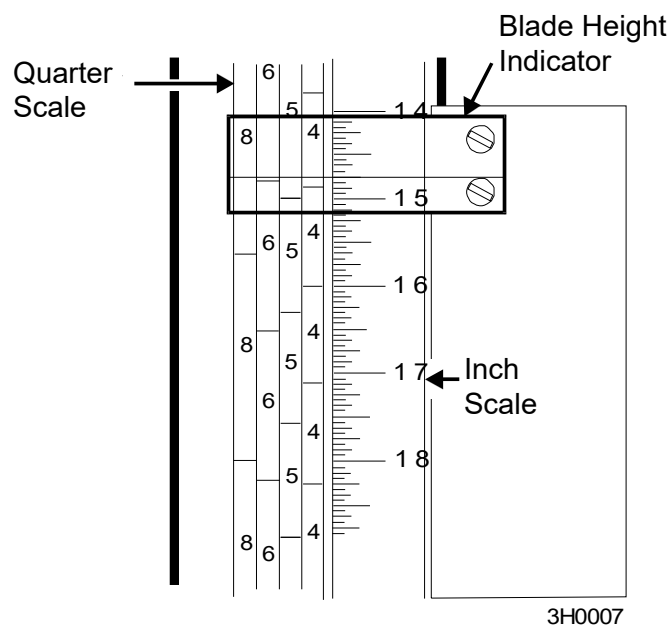

FIG. 5-30

3. Loosen the indicator bracket mounting bolts and adjust the bracket until the indicator is aligned with the correct mark on the scale. Retighten the bracket mounting nut.

For example, if the measurement from blade to bed rail was 14 3/4" (375 mm), make sure the indicator reads 14 3/4" (375 mm) on the scale.

SECTION 6 MOTOR BRAKE

6.1 Motor Brake Maintenance

Maintenance intervals

Service brakes	<ul style="list-style-type: none"> ■ after 4000 hours of operation at the latest or every six months
-----------------------	---

TABLE 6-1.



IMPORTANT! Brakes with defective armature plates, cheese head screws, springs or flanges must be replaced completely.

Please observe the following for inspections and maintenance operations:

- Remove impurities through oil and grease using brake cleaning agents, if necessary, replace brake after finding out the cause of the contamination. Dirt deposits in the air gap between stator and armature plate impair the function of the brake and must be removed.
- After replacing the rotor, the original braking torque will not be reached until the run-in operation of the friction surfaces has been completed. After replacing the rotor, run-in armature plates and flanges have an increased initial rate of wear.

Checking the rotor thickness



DANGER! The motor must not be running when checking the rotor thickness.

- Remove the motor cover and seal ring (if mounted).
- Measure the rotor thickness with a caliper gauge. On brakes with friction plates, observe edging on outer diameter of friction plate.
- Compare measured rotor thickness with minimally permissible rotor thickness. [See Table 6-2.](#)
- Replace the complete rotor if necessary.

Check the air gap

- Measure the air gap "sL_ü" between armature plate and rotor using a feeler gauge (see chapter 3.3).
- Compare the measured air gap to the maximum permissible air gap "sL_{ümax}." (see table below).

- If necessary, adjust the air gap to "sLürated".

Brake type	sLürated +0.1mm -0.05mm	sLümax Service brake	Max. adjustment permissible wear	Rotor thickness		Excess of the adjuster nut h _E max. [mm]
				min. ¹⁾ [mm]	max. [mm]	
INTORQ BFK458-25	0,4 mm (1/64")	1,0 mm (3/64")	4,0 mm (5/32")	12 mm (15/32")	16 mm (5/8")	17 mm (43/64")

TABLE 6-2.

EC declaration of conformity
according to EC Machinery Directive 2006/42/EC, Annex II, 1.A**Manufacturer:**Wood-Mizer Industries sp. z o.o.
Nagórna 114, 62-600 Koło; Poland
Tel. +48 63 26 26 000

This declaration of conformity is issued under the sole responsibility of the manufacturer.

Following machine in our delivered version complies with the appropriate essential safety and health requirements of the EC Machinery Directive 2006/42/EC based on its design and type, as brought into circulation by us. In case of alteration of the machine, not agreed by us, this declaration is no longer valid.

We, the undersigned herewith declare, that:Designation of the machine: Sawmill
Type: LT40
Serial Number:**Is in conformity with the following
EC directives:**EC Machinery Directive 2006/42/EC
EC Electromagnetic Compatibility Directive 2014/30/EU**And is in conformity with the following
Harmonized Standards:**PN-EN 1807-2: 2013-08
PN-EN ISO 13849-1:2016-02
PN-EN 60204-1:2018-12Notified Body according to annex IV : Sieć Badawcza Łukasiewicz
INSTYTUT TECHNOLOGII DREWNA
Centrum Certyfikacji Wyrobów Przemysłu Drzewnego
Winiarska 1, 60-654 Poznań

Notification No: 1583

EC type - examination certificate no: 0758/2020

Responsible for Technical Documentation: Piotr Adamiec / Engineering Manager
Wood-Mizer Industries Sp. z o.o.
62-600 Koło, ul. Nagórna 114, Poland
Tel. +48 63 26 26 000

Place / Date / Authorized Signature

Koło, 14.02.2020



Title:

Engineering Manager