

Wood-Mizer®

Parts Manual

LT70M DH Super

rev. A9.00



Safety is our #1 concern! Read and understand all safety information and instructions before operating, setting up or maintaining this machine.

August 2006

Form #1054

Table of Contents

Section-Page

SECTION 1	GENERAL INFORMATION	1-1
1.1	How To Use The Parts List	1-1
1.2	Sample Assembly	1-1
SECTION 2	BLADE GUIDE ROLLERS & ARM	2-1
2.1	Blade Guide Assembly, Idle Side	2-1
2.2	Blade Guide Assembly, Drive Side	2-2
2.3	Blade Guide Arm Drive Assembly.....	2-4
2.4	Blade Guide Mount Assembly, Drive Side	2-6
SECTION 3	BLADE WHEELS & TENSIONER	3-1
3.1	Blade Drive Assembly.....	3-1
3.2	Idle Blade Wheel Assembly	3-2
3.3	Hydraulic Blade Tensioner Assembly.....	3-4
3.4	Sawdust Flow Guide.....	3-6
SECTION 4	SAW HEAD	4-1
4.1	Middle Throat Screw	4-1
4.2	Drive Belt Tensioner LT70 AC.....	4-1
4.3	Board Return Assembly (Optional)	4-2
4.4	Water Lube Assembly	4-4
4.5	LT70AC Saw Head Decals	4-5
4.6	Blade Housing Covers.....	4-7
4.7	Sawdust Chute	4-8
4.8	Saw Head Protection Kit, LT70M Mobile	4-9
SECTION 5	CONTROL BOXES	5-1
5.1	Control Assembly, LT70 AH	5-1
5.2	Drum Switches	5-3
5.3	Circuit Breakers.....	5-4
5.4	Front Panel Assembly & Harnesses	5-5
5.5	Solenoids	5-6
SECTION 6	UP/DOWN SYSTEM	6-1
6.1	Up/Down Rollers & Covers	6-1
6.2	Blade Height Scale	6-2
6.3	Up/Down Chain & Sprockets.....	6-3
6.4	Up/Down Drive Assembly	6-4
6.5	Safety Switches	6-6
SECTION 7	FEED SYSTEM & TRACK ROLLERS	7-1
7.1	Upper Track Rollers And Wipers.....	7-1
7.2	Power Feed Assembly	7-3
7.3	Feed Chain/Stop, LT70 S/M	7-5
7.4	Lower Track Rollers.....	7-6

Table of Contents

Section-Page

SECTION 8 BED FRAME ASSEMBLY

8-1

8.1	Bed Rail Assembly, Front (LT40/70M Super).....	8-1
8.2	Bed Rail Assembly, Middle (LT40/70M Super).....	8-2
8.3	Board Removal Assembly, "Super" Series Stationary Sawmills w/"M" Frame	8-3
8.4	Board Removal Assembly, Portable "Super" Series Sawmills w/"M" Frame	8-5
8.5	Board Return Assembly - (LT40M Super Option)	8-7
8.6	Board Return Assembly - (LT70M Super Option)	8-8
8.7	Long Table	8-9
8.8	Stationary Leg Kit, M Super Frame	8-11
8.9	Outrigger Leg Kit, M Super Frame	8-12
8.10	LT40/70M Saw Head Rest Pin Assembly	8-13
8.11	Tie Down Chain Assembly	8-14
8.12	Blockade Control Box LT40	8-15
8.13	Remote Equipment Option	8-16

SECTION 9 HYDRAULIC SYSTEM

9-1

9.1	Hydraulic Hoses, LT40/70M Super	9-1
	<i>Protective Conduits, LT40/70M Super Hydraulic Hoses</i>	
9.2	Hydraulic Control Box, LT40/70M Super (AC).....	9-3
9.3	Hydraulic & Wireless Control Box	9-5
9.4	Wireless Control Assembly (Option).....	9-7
9.5	Hydraulic Log Loader, S/M Frame	9-8
9.6	Hydraulic Log Loader for "M" Super Frames	9-10
9.7	Hydraulic Log Turner.....	9-12
9.8	Hydraulic Log Side Supports (for Stationary Sawmills).....	9-14
9.9	Hydraulic Log Side Supports (for Mobile Sawmills).....	9-16
9.10	Hydraulic Pull-Down Clamp.....	9-18
9.11	Hydraulic Log Clamp - main.....	9-20
9.12	Hydraulic Log Side Supports (Super Version).....	9-22
9.13	Hydraulic Toe Board	9-24
9.14	Power Toe Roller.....	9-25

SECTION 1 GENERAL INFORMATION

1.1 How To Use The Parts List

- Use the index above to locate the assembly that contains the part you need.
- Go to the appropriate section and locate the part in the illustration.
- Use the number pointing to the part to locate the correct part number and description in the table.
- Parts shown indented under another part are included with that part.
- Parts marked with a diamond (◆) are only available in the assembly listed above the part.

See the sample table below. Sample Part #A01111 includes part F02222-2 and subassembly A03333. Subassembly A03333 includes part S04444-4 and subassembly K05555. The diamond (◆) indicates that S04444-4 is not available except in subassembly A03333. Subassembly K05555 includes parts M06666 and F07777-77. The diamond (◆) indicates M06666 is not available except in subassembly K05555.

1.2 Sample Assembly				
REF	DESCRIPTION (◆ Indicates Parts Available In Assemblies Only)	PART #	QTY.	
	Sample Assembly, Complete (Includes All Indented Parts Below)	A01111	1	
1	Sample Part	F02222-22	1	
	Sample Subassembly (Includes All Indented Parts Below)	A03333	1	
2	Sample Part (◆ Indicates Part Is Only Available With A03333)	S04444-4	1	◆
	Sample Subassembly (Includes All Indented Parts Below)	K05555	1	
3	Sample Part (◆ Indicates Part Is Only Available With K05555)	M06666	2	◆
4	Sample Part	F07777-77	1	

To Order Parts:

- From Europe call our European Headquarters and Manufacturing Facility in Kolo, Poland at **+48-63-2626000**. From the continental U.S., call our toll-free Parts hotline at **1-800-525-8100**. Have your customer number, vehicle identification number, and part numbers ready when you call. From other international locations, contact the Wood-Mizer distributor in your area for parts.

Office Hours:

Country	Monday - Friday	Saturday	Sunday
Poland	7-15	Closed	Closed
US	8 a.m.- 5 a.m.	8 a.m.- 12 p.m.	Closed



CAUTION! It is strongly recommended that only original spare parts be used.

SECTION 2 BLADE GUIDE ROLLERS & ARM

2.1 Blade Guide Assembly, Idle Side

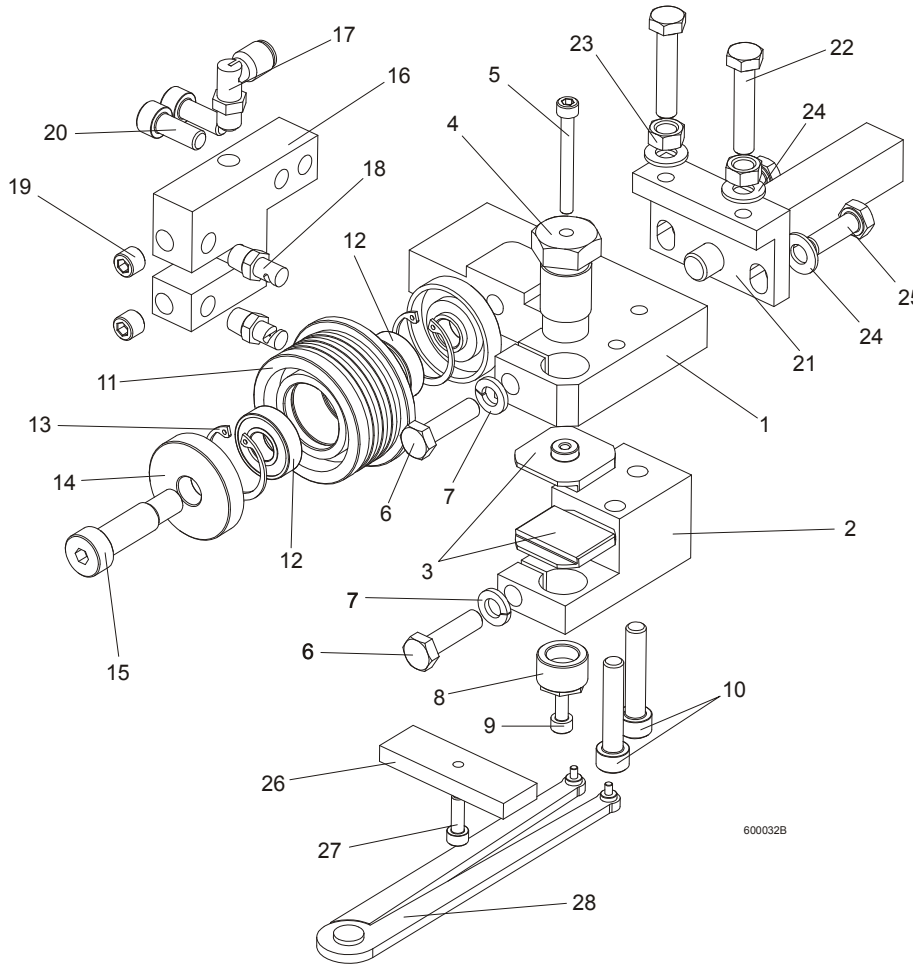

REF.	DESCRIPTION (◆ Indicates Parts Available In Assemblies Only)	PART#	QTY.
	BLADE GUIDE ASSEMBLY, IDLE SIDE, EXTENDED (for optional use with 1 1/2" blades)	092997	1
1	Block, Blade Guide Mount Zinc-plated	090947-1	1
2	Block, Lower Ceramic Pad Mount Zinc-plated	090948-1	1
3	Block, Blade Guide Zinc	093430-1	2
4	Bolt, Upper Pad Adjustment Zinc-plated	089515-1	1
5	Screw, M5x45 DIN912 A2-70 Hex Socket Head Cap Stainless Steel	F81000-24	1
6	Bolt, M8x30 DIN933 A2-70 Stainless Steel	F81002-27	2
7	Washer, 8.2 Split Lock Zinc	F81054-4	2
8	Screw, Lower Pad Adjuster Zinc-plated	516191-1	1
9	Screw, M5x10 DIN912 A2-70 Hex Socket Head Cap Stainless Steel	F81000-23	1
10	Screw, M8x40-8.8 Hex Socket Head Cap Zinc	F81002-29	2
	Roller, Blade Guide W/Bearing, Extended	092939	1
11	Roller, Blade Guide Extended	087890	1
12	Bearing, 6001 2RSR NACHI	087893	2
13	Ring, W28 Inside Retaining	F81090-9	2

2 BLADE GUIDE ROLLERS & ARM

Blade Guide Assembly, Drive Side

14	Washer, Blade Guide Roller Spacer Zinc-plated	087891-1	1	
	Washer, Blade Guide Roller Spacer Zinc-plated	087892-1	1	
15	Screw, 12/M10x30 12.9 ISO 7379 Socket Head Shoulder	F81003-70	1	
	Screw, 12/M10x35 12.9 ISO 7379 Socket Head Shoulder, (used with the Extended Roller only)	F81003-48	1	
16	Block, Nozzle Mounting Zinc-plated	090487-1	1	
17	Fitting, 90° Elbow 1/8NPT-1/4 Tube Swivel	P09736	1	
18	Nozzle, Blade Lube Spray	033479	2	
19	Plug, M10x1 DIN 906 BN40 "BOSSARD"	F81015-3	2	
20	Screw, M8x20-8.8 Hex Socket Head Cap Zinc	F81002-30	2	
21	Pivot Weldment, Blade Guide Zinc-plated	089509-1	1	
22	Bolt, M8x40 DIN933 A2-70 Stainless Steel	F81002-28	2	
23	Nut, M8 DIN934 A2-70 Stainless Steel	F81032-7	2	
24	Washer, 8.4 Zinc Flat	F81054-1	4	
25	Bolt, M8x25 DIN933 A2-70 Stainless Steel	F81002-26	2	
	Block, Blade Guide Alignment	090951	1	
26	Block, Blade Guide Alignment Zinc-plated	090805-1	1	
27	Screw, M5x16-8.8 Hex Socket Head Cap Zinc	F81000-25	1	
28	Tool, 62860-3 (PERSCHMAN) Lower Pad Adjustment	090949	1	

2.2 Blade Guide Assembly, Drive Side

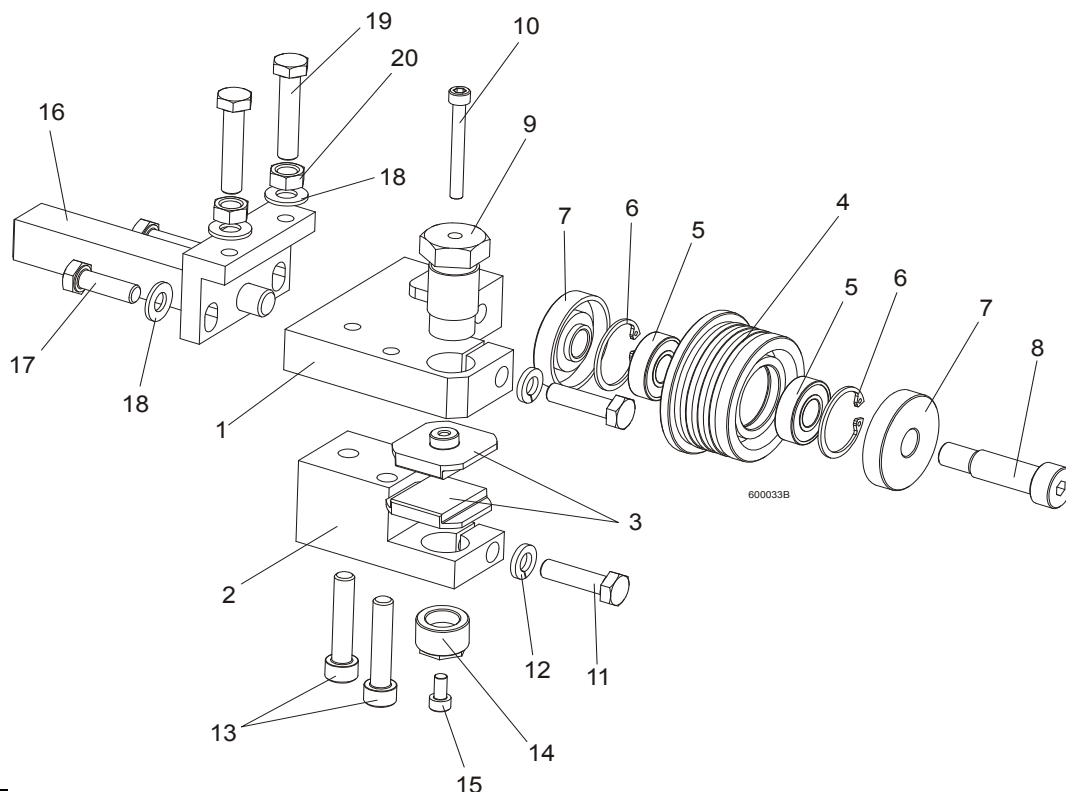

REF.	DESCRIPTION (◆ Indicates Parts Available In Assemblies Only)	PART#	QTY.	
	BLADE GUIDE ASSEMBLY, DRIVE SIDE, EXTENDED (for optional use with 1 1/2" blades)	092998	1	
1	Block, Blade Guide Mount Zinc-plated	090944-1	1	
2	Block, Lower Ceramic Pad Mount Zinc-plated	090946-1	1	

3	Block, Blade Guide Zinc	093430-1	2	
	Roller, Blade Guide W/Bearing, Extended	092939	1	
4	Roller, Blade Guide Extended	087890	1	
5	Bearing, 6001 2RSR NACHI	087893	2	◆
6	Ring, W28 Inside Retaining	F81090-9	2	
7	Washer, Blade Guide Roller Spacer Zinc-plated	087891-1	1	
	Washer, Blade Guide Roller Spacer Zinc-plated	087892-1	1	
8	Screw, 12/M10x30 12.9 ISO 7379 Socket Head Shoulder	F81003-70	1	
	Screw, 12/M10x35 12.9 ISO 7379 Socket Head Shoulder (used with the Extended Roller only)	F81003-48	1	
9	Bolt, Upper Pad Adjustment	089515	1	
10	Screw, M5x45 DIN912 A2-70 Hex Socket Head Cap Stainless Steel	F81000-24	1	
11	Bolt, M8x30 DIN933 A2-70 Stainless Steel	F81002-27	2	
12	Washer, 8.2 Split Lock Zinc	F81054-4	2	
13	Screw, M8x40-8.8 Hex Socket Head Cap Zinc	F81002-29	2	
14	Screw, Lower Pad Adjustment Zinc-plated	516191-1	1	
15	Screw, M5x10 DIN912 A2-70 Hex Socket Head Cap Stainless Steel	F81000-23	1	
16	Pivot Weldment, Blade Guide Zinc-plated	089509-1	1	
17	Bolt, M8x25 DIN933 A2-70 Stainless Steel	F81002-26	2	
18	Washer, 8.4 Zinc Flat	F81054-1	4	
19	Bolt, M8x40 DIN933 A2-70 Stainless Steel	F81002-28	2	
20	Nut, M8 DIN934 A2-70 Stainless Steel	F81032-7	2	

2 BLADE GUIDE ROLLERS & ARM

Blade Guide Arm Drive Assembly

2.3 Blade Guide Arm Drive Assembly

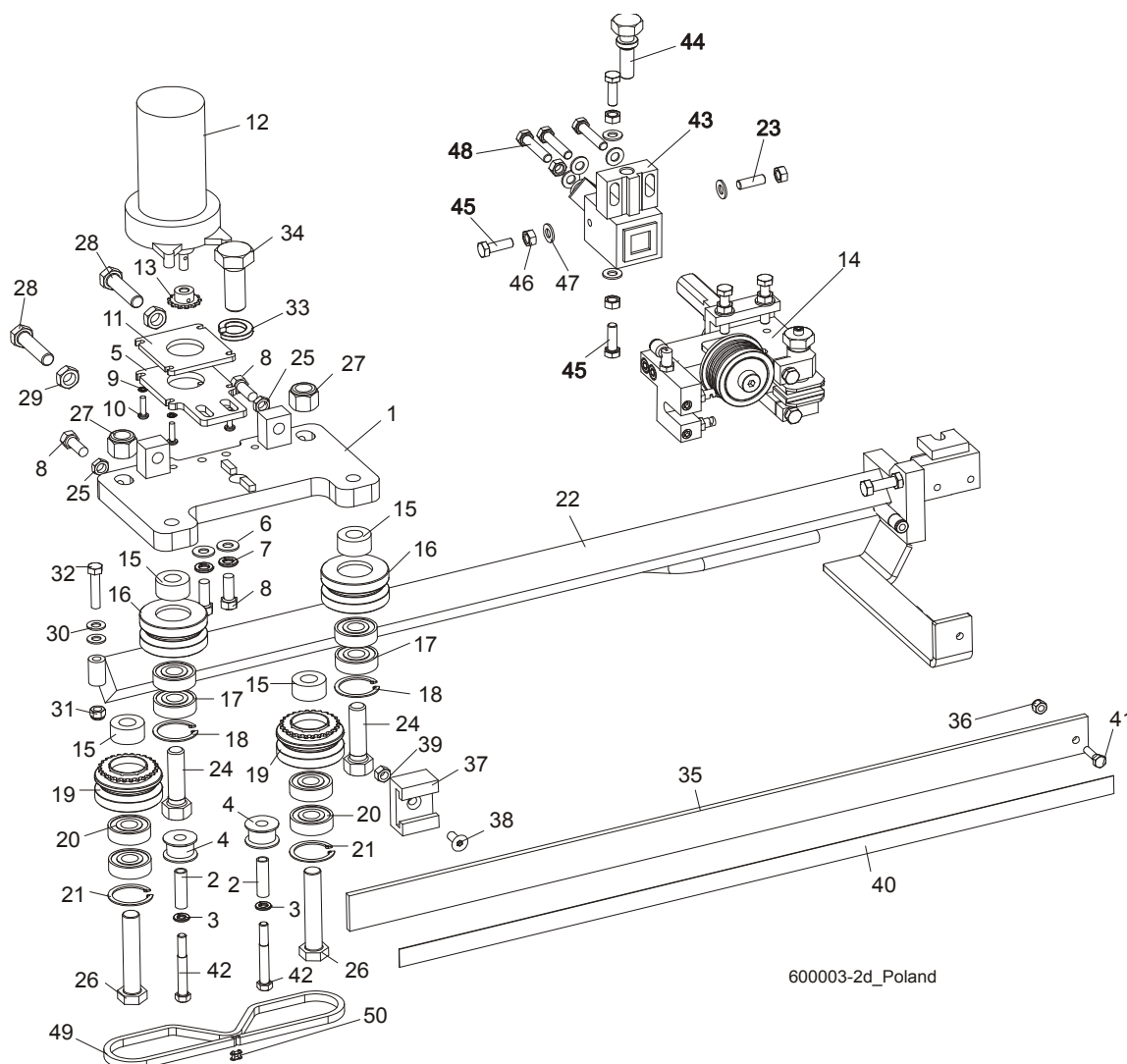

REF.	DESCRIPTION (◆ Indicates Parts Available In Assemblies Only)	PART#	QTY.
	BLADE GUIDE ARM ASSEMBLY	090950	1
1	Plate Weldment, Blade Guide Arm Zinc-plated	090800-1	1
2	Bushing, 0.322 x 0.44 x 1 1/2" Spacer	S09996	2
3	Washer, 5/16" Split Lock Zinc	F05011-13	2
4	Roller, Chain Guide	090801	2
5	Plate, Blade Guide Motor Mount Ptd	090803-1	1
6	Washer, 10.5 Zinc Flat	F81055-1	2
7	Washer, 3/8" Zinc Flat	F05011-4	2
8	Bolt, M10 x 25 8.8 Hex Head Full Thread	F81003-31	4
9	Washer, 5.3 Zinc Flat	F81052-1	4
10	Screw, #10-32 x 3/4 CrS1 Phillips Head	F05004-38	4
11	Plate, Spacer Ptd	090802-1	1
12	Motor, 53:1 Gear ASA Blade Guide Arm	P09698-1	1
13	Sprocket, 25B13 x .3130	P09970	1
14	Pin, 3 x 14 Zinc Roll	F81044-4	1

BLADE GUIDE ROLLERS & ARM

Blade Guide Arm Drive Assembly

2

15	Spacer, Drive Roller Zinc-plated	090804-1	4	
	ROLLER ASSEMBLY, BLADE GUIDE ARM IDLER	042543	2	
16	Housing, 2 1/2" V-Groove	042536	1	
17	Bearing, 6203 2RSP6-5/8 CX	095087	2	
18	Ring, 1.575" ID 5002-156 Retaining	F04254-8	1	
	ROLLER ASSEMBLY, BLADE GUIDE ARM DRIVE	042542	2	
19	Housing, 2 1/2" V-Groove W/Sprocket	042541	1	
20	Bearing, 6203 2RSP6-5/8 CX	095087	2	
21	Ring, 1.575" ID 5002-156 Retaining	F04254-8	1	
22	Arm Weldment, Blade Guide Zinc-plated	090479-1	1	
23	Screw, Set, M8x8-33H FE/ZN Hex Socket Head, Stainless	F81014-3	1	
24	Bolt, 5/8-18 x 2 1/4 Hex Head Grade 5	F05009-80	2	
25	Nut, M10-04-W Zinc Hex Thin	F81033-6	2	
26	Bolt, 5/8-18 x 3 1/4 Hex Head Grade 5	F05009-80	2	
27	Nut, 5/8-18 Hex Nylon Lock	F05010-71	2	
28	Screw, M12 x 1.25 x 60-33H Zinc Hex Set W/Full Dog Point	F81004-52	2	
29	Nut, M12 x 1.25 8.8 Zinc Hex Thin	F81034-5	2	
30	Washer, 8.4 Zinc Flat	F81054-1	1	
31	Nut, M8-8-B Hex Nylon Zinc Lock	F81032-2	1	
32	Bolt, M8 x 40-8.8 Hex Head Full Thread Zinc	F81002-15	1	
33	Washer, DIN 6319-21C Spherical	F81059-6	1	
34	Bolt, M20 x 1.5 x 50-8.8-B Hex Head Full Thread Zinc	F81007-2	1	
35	Guard, Blade	088306	1	
36	Nut, M6-8-B Hex Nylon Zinc LOKK	F81031-2	1	
37	Guide, Blade Guard	088305	1	
38	Screw, M8 x 25 Cross Recessed Countersunk Head Zinc	F81002-51	1	
39	Nut, M8-8-B Hex Nylon Zinc Lock	F81032-2	1	
40	Decal, Warning	015849	1	
41	Bolt, M6 x 20-8.8 Hex Head Full Thread Zinc	F81001-2	2	
42	Screw, 12/M10 x 20 12.9 ISO7379(BOSSARD) Socket Head Shoulder	F81003-68	2	
43	Mounting Block, LT70 Blade Guide, zinc	089503-1	1	
44	Bolt, Blade Guide Adjustment, zinc	506552-1	1	
45	Bolt, M8x25 DIN933 A2-70, Stainless	F81002-26	3	
46	Nut, M8 DIN934 A2-70, Stainless	F81032-7	5	
47	Washer, 8.4 FLAT,ZINC	F81054-1	7	
48	Bolt M8x40 DIN933 A2-70, Stainless	F81002-28	3	
49	Blade Guide Parts (See Section 2.1)	092997	1	
	Chain, #25 x 92 PITCHES B/G	093805	1	
50	Chain, #25 x 92 Pitches B/G	042443	1	
51	KETTENGLIED #25	P09983	1	

2 BLADE GUIDE ROLLERS & ARM

Blade Guide Mount Assembly, Drive Side

2.4 Blade Guide Mount Assembly, Drive Side

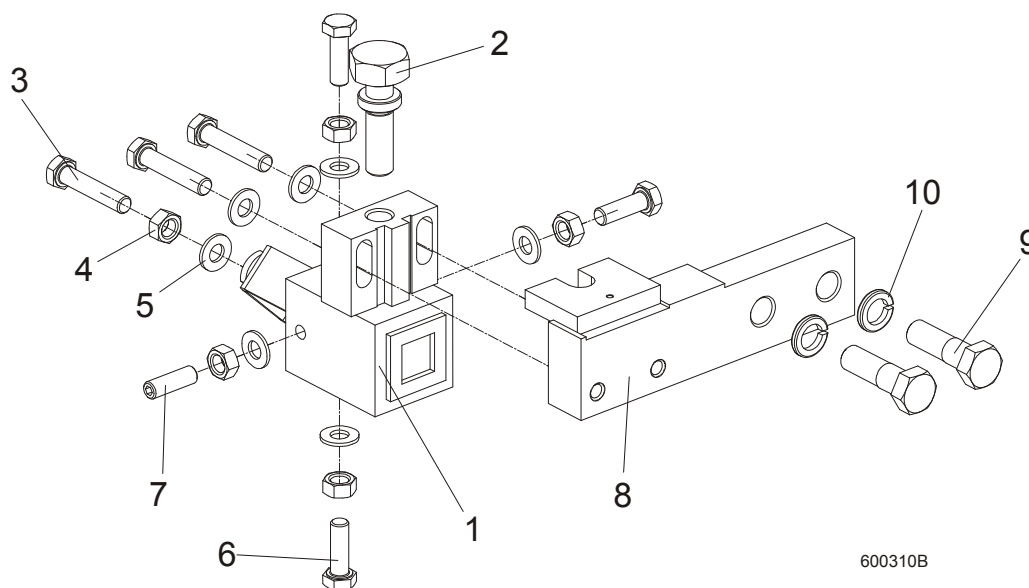

600310B

REF.	DESCRIPTION (◆ Indicates Parts Available In Assemblies Only)	PART#	QTY.
	MOUNTING BLOCK, DRIVE SIDE	091338	1
1	MOUNTING BLOCK, BLADE GUIDE, DRIVE SIDE, ZINC	089503-1	1
2	BOLT, BLADE GUIDE ADJUSTMENT, ZINC	506552-1	1
3	BOLT, M8X40 DIN933 A2-70, STAINLESS	F81002-28	3
4	NUT, M8 DIN934 A2-70, STAINLESS	F81032-7	5
5	WASHER, 8.4 FLAT,ZINC	F81054-1	7
6	BOLT, M8X25 DIN933 A2-70, STAINLESS	F81002-26	3
7	SCREW, BLADE GUIDE ADJUSTMENT, M8X25 A2-70 DIN 913, STAINLESS	F81014-3	1
8	BAR, BLADE GUIDE MOUNT, ZINC	089501-1	1
9	BOLT,M12X40-8.8 HEX HEAD ZINC	F81004-1	2
10	WASHER, M12 SPLIT LOCK ZINC	F81056-2	2

SECTION 3 BLADE WHEELS & TENSIONER

3.1 Blade Drive Assembly

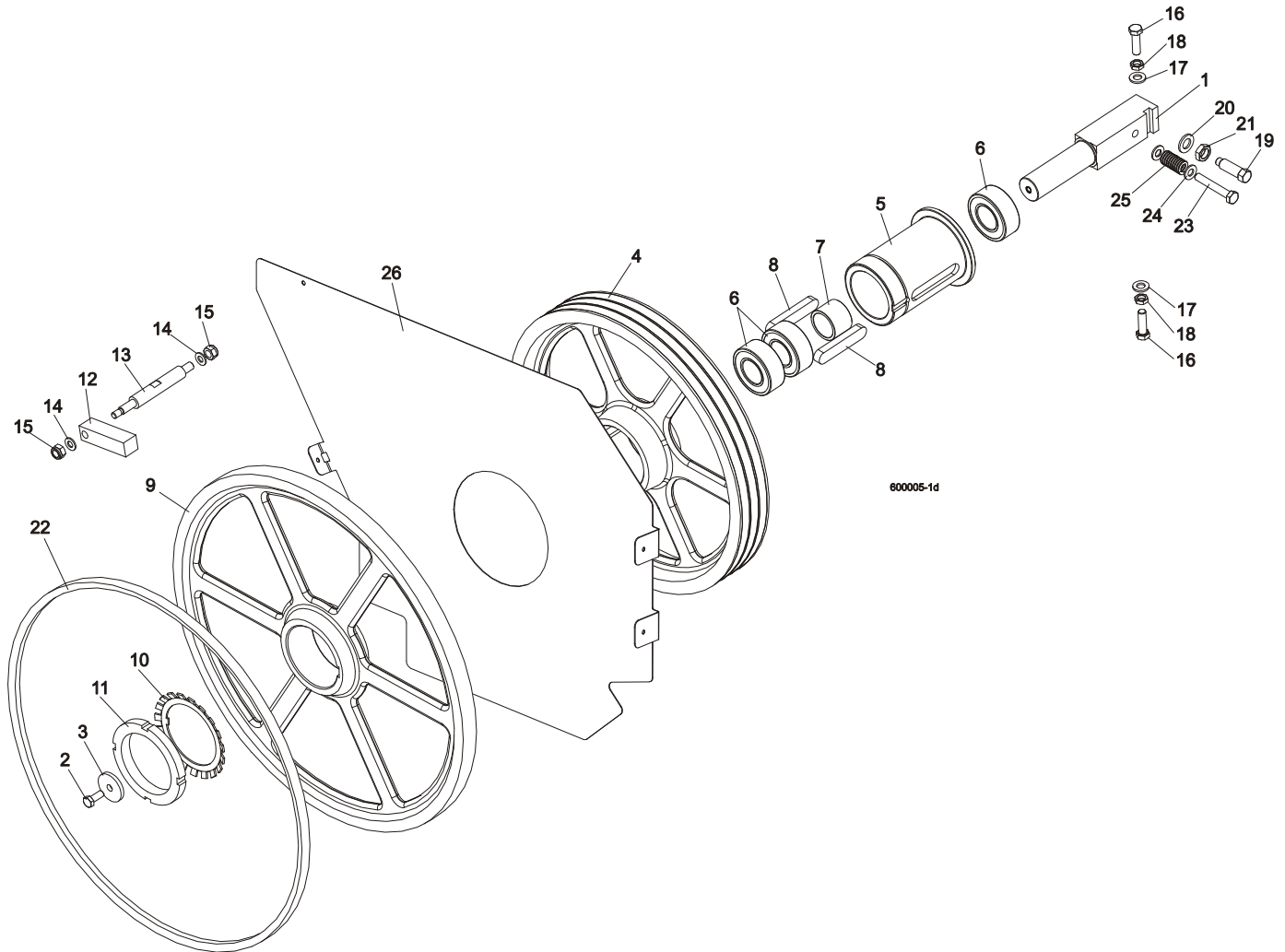

REF	DESCRIPTION (◆ Indicates Parts Available In Assemblies Only)	PART #	QTY.
1	SHAFT, BLADE DRIVE WHEEL	088475	1
2	BOLT, M10x25 8.8 HEX HEAD FULL THREAD	F81003-31	1
3	WASHER, BLADE DRIVE WHEEL	088956-1	1
	PULLEY ASSEMBLY, BLADE DRIVE	504808	1
4	Pulley, 3-Groove 484 mm Diameter	089457-1	1
5	Bushing, Blade Drive Wheel	504809	1
6	Bearing, 3208.2rsr.tvh (FAG) Rolling	088449	3
7	Spacer, 51x41x36.3 Drive Bearing	504810	1
8	Key, A20x12x100 Parallel	088477	2
9	WHEEL, BLADE DRIVE	090811	1
10	WASHER, MB21 (FAG) LOCK	088451	1
11	NUT, KM21(M105X2) (FAG) LOCK	088450	1
12	BAR, WHEEL SCRAPER	088781	1
13	SHAFT, WHEEL SCRAPER	088780-1	1

3

Blade Wheels & Tensioner

Idle Blade Wheel Assembly

14	WASHER, 10.5 ZINC FLAT	F81055-1	2	
15	NUT, M12-8 HEX NYLON ZINC LOCK	F81034-2	2	
16	BOLT, M12X1.25X40 HEX HEAD	F81004-42	3	
17	WASHER, 13 FLAT ZINC	F81056-1	3	
18	NUT, M12X1.25 8.8 THIN ZINC	F81034-5	3	
19	SCREW, M16X1.5X50-33H HEX HEAD FULL DOG POINT SET ZINC	F81006-14	1	
20	WASHER, 17 ZINC FLAT	F81058-1	1	
21	NUT, M16x1.5-08-B ZINC THIN	F81036-6	1	
22	BELT, BLADE WHEEL B72.5	017922-1	1	
23	BOLT M10X65	F81003-67	1	
24	WASHER, 10.5 ZINC FLAT	F81055-1	2	
25	SPRING19X38	034430	1	
26	PLATE, LT70AC SAW HEAD (OPTION)	100897-1	1	
	BELT 3B/HB2462 La	089464	1	

3.2 Idle Blade Wheel Assembly

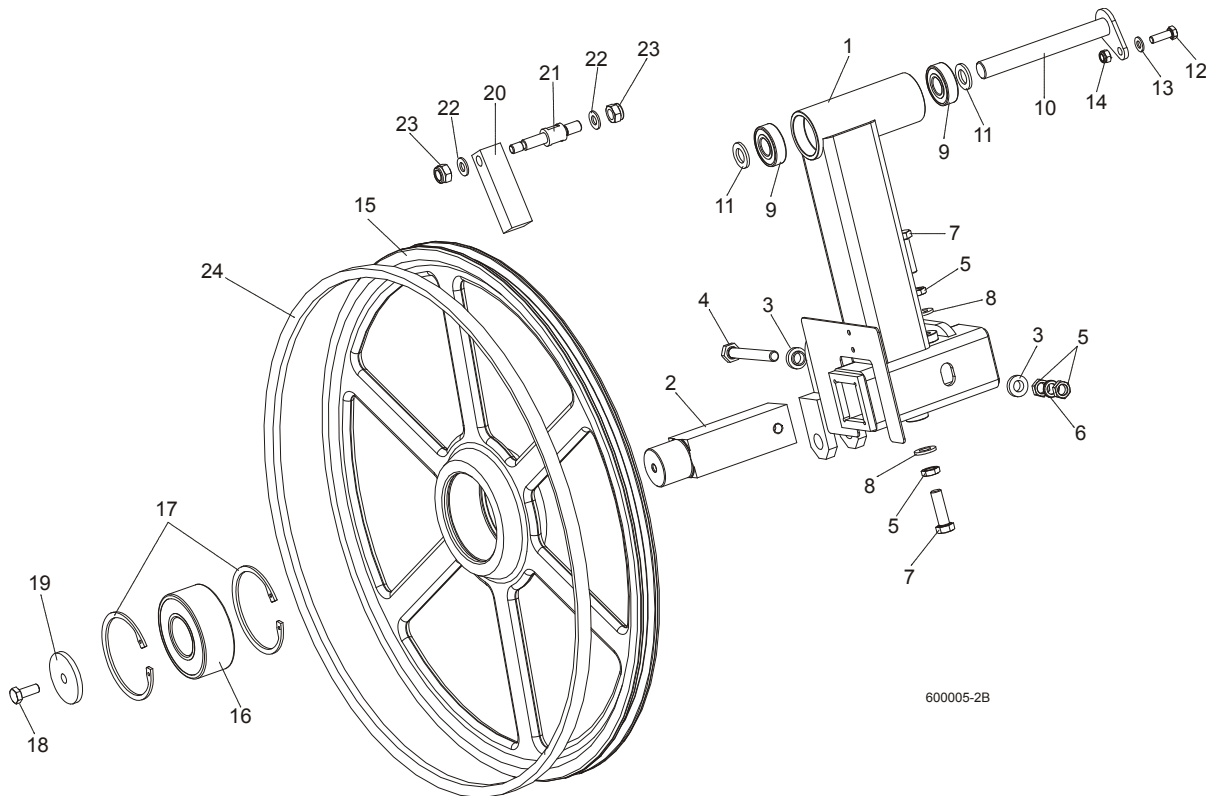

REF	DESCRIPTION (◆ Indicates Parts Available In Assemblies Only)	PART #	QTY.
	TUBE, LT70 IDLE SIDE BLADE WHEEL W/LEVER COMPLETE	092791	1
1	Tube Weldment, LT70 Idle Blade Wheel w/Lever	092780-1	1
2	Shaft, Idle Blade Wheel	088474	1
3	Washer, Zinc Special	086769-1	2
4	Bolt, M12x1.25x100-8.8 Hex Head Zinc	F81004-41	1
5	Nut, M12x1.25 8.8 Hex ZincThin	F81034-5	4
6	Washer, Z12.2 Split Zinc Lock	F81056-2	1
7	Bolt, M12x1.25x40 Hex Head	F81004-42	2
8	Washer, 13 Zinc Flat	F81056-1	2

9	Bearing, 6204 2RS-CX Rolling	088447	2	
10	PIN WELDMENT, PIVOT	088759-1	1	
11	WASHER, 17 ZINC FLAT	F81058-1	2	
12	BOLT, M8X25-8.8-B HEX HEAD FULL THREAD ZINC	F81002-5	1	
13	WASHER, 8.4 ZINC FLAT	F81054-1	1	
14	NUT, M8-8-B HEX NYLON ZINC LOCK	F81032-2	1	
	WHEEL ASSEMBLY, IDLE SIDE	088764	1	
15	Wheel, Blade Idle Side	090810	1	
16	Bearing, 3309B.2RSR.TVH-P66 FAG	086428	1	
17	Ring, W100 Spring Retaining	F81090-10	2	
18	BOLT, M10X25 8.8 HEX HEAD FULL THREAD	F81003-31	1	
19	WASHER, IDLE BLADE WHEEL RETAINING	088957-1	1	
20	SCRAPER, IDLE BLADE WHEEL	088781	1	
21	SHAFT, SHORT ZINC WHEEL SCRAPER	088779-1	1	
22	WASHER, 10.5 ZINC FLAT	F81055-1	2	
23	NUT, M12-8 HEX NYLON ZINC LOCK	F81034-2	2	
24	BELT, BLADE WHEEL B72.5	017922-1	1	

3 Blade Wheels & Tensioner

Hydraulic Blade Tensioner Assembly

3.3 Hydraulic Blade Tensioner Assembly

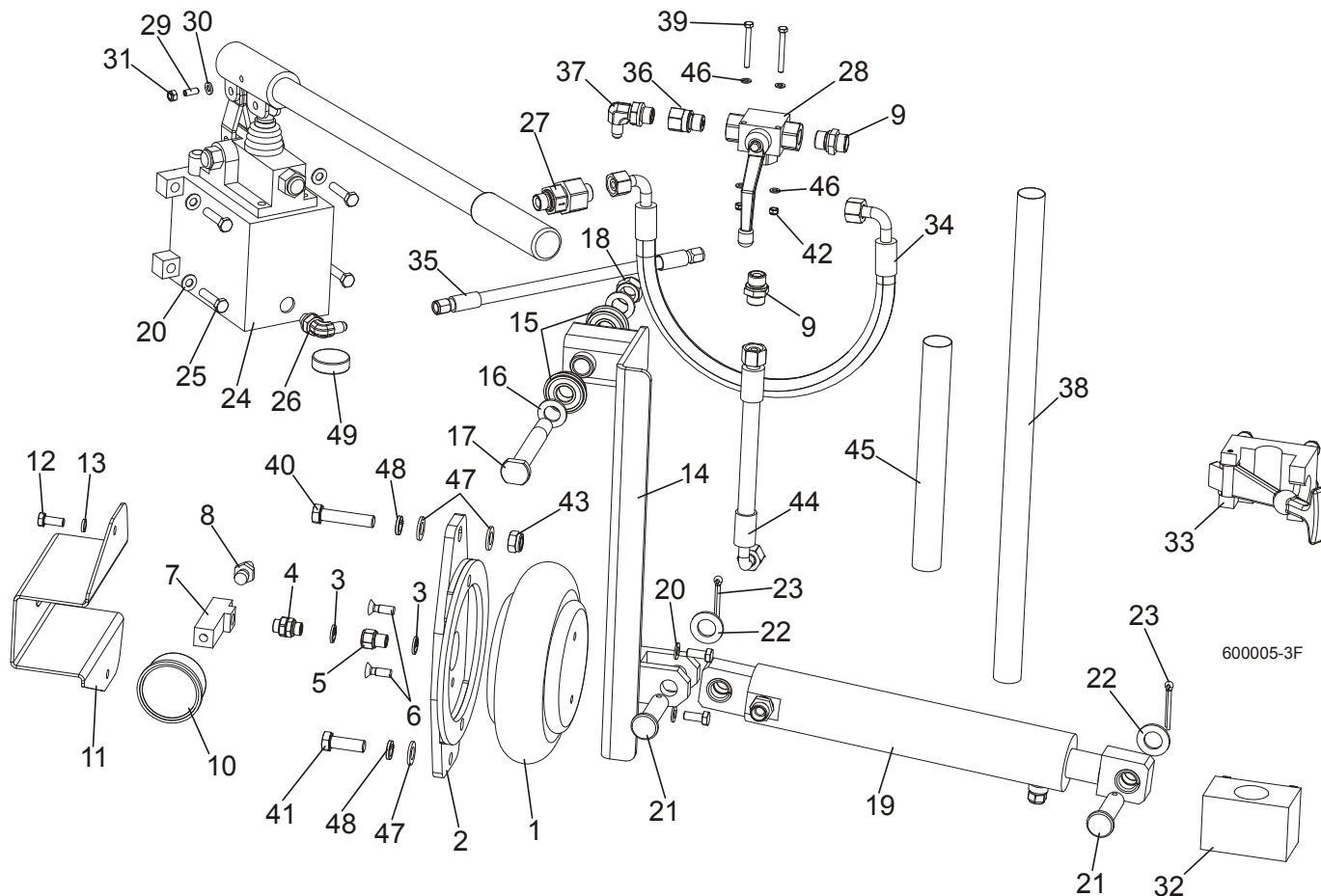

REF	DESCRIPTION (◆ Indicates Parts Available In Assemblies Only)	PART #	QTY.
	HYDRAULIC BLADE TENSIONER, COMPLETE	504801	1
1	BAG, POJ 192 308 100 0 AIR	088576	1
2	BRACKET, AIR BAG MOUNT	088798-1	1
3	SEAL, G1/4 866-014-000-0	090809	4
4	NIPPLE, 1/4 8632141400)BOSCH	097703	1
5	FITTING, 1/4 THREAD/1/4 THREAD 2521	097704	1
6	BOLT, M8X25 PAN HEAD ZINC	F81002-51	2
7	TEE CONNECTOR, SPECIAL	097702-1	1
8	FITTING, 1/4" THREAD 390 004 004 0 (REXROTH) AIR TANK VALVE	088575	1
9	FITTING, HD-GE-12L-BE-06 STRAIGHT	094561	2
10	GAUGE, M63T-2,5/20G G 1/8 0-0,6 MPA/PSI AIR PRESSURE	088568	1
11	GUARD, AIR PRESSURE GAUGE	088924-1	1
12	SCREW, M8X25 CROSS RECESSED COUNTERSUNK HEAD ZINC	F81002-4	4
13	WASHER 8.2 ZINC SPLIT	F81054-4	2
14	ARM, AIR CYLINDER PAINTED	092779-1	1
15	BEARING W/SNAP RING 6203-2RS	086395	2
16	WASHER, 17 FLAT ZINC	F81058-1	2
17	PIN, IDLER ARM MOUNT	086404	1
18	NUT, M16, HEX, NYLON ZINC LOCK	F81036-2	2

19	CYLINDER, HYDRAULIC COMPLETE	092788	1	
	CYLINDER, SHDJ050/030X80 HYDRAULIC	092787-1	1	
	BUSHING, TUF1 18x120 CX	500106	4	
	FITTING, HD-GE-12L-BE-06 STRAIGHT	094561	1	
	VALVE, 2901-14-17 AIR VENT	090794	1	
20	WASHER, 8.4 ZINC FLAT	F81054-1	6	
21	PIN, PN-EN 22341-B-18X65X57-A2	F81049-4	2	
22	WASHER, 19 FLAT ZINC	F81060-1	2	
23	PIN, S-ZN 5X40 PN-M/82001	F81043-31	2	
24	PUMP,PMS12/TNK1 MANUAL W/TANK 1L	092789-1	1	
25	BOLT, 8MM X 1.25X35MM HH ZINC	F81002-13	4	
26	ELBOW, CA-204410-3	094562	1	
27	VALVE, RHV12LREDA3C CHECK	094559	1	
28	VALVE, BALL 3-WAY RSAP3 VOL2L G3/8"	504803	1	
29	LATCH, GN615.3-M6-KN BALL THREADED	096874	1	
30	WASHER, M6, FLAT, ZINC	F81053-1	1	
31	NUT, M6, HEX, NYLON LOCK ZINC	F81031-2	1	
32	BRACKET, TENSIONER PUMP HANDLE BOTTOM	096951	1	
33	BRACKET, TENSIONER PUMP HANDLE UPPER	092800	1	
34	HOSE, DN10 W/FITTING 10AOL 90 M18X1.5	504804	1	
35	HOSE, 1/4 W/FITTING JIC 7/16-20	504805	1	
36	FITTING, G 3/8 THROTTLE	096849	1	
37	ELBOW, CA-204411-3	094563	1	
38	HOSE PROTECTION	505178	1	
39	BOLT, M5X45 DIN933 A2-70 STAINLESS STEEL	F81000-22	2	
40	BOLT, M12X55-8.8 HEX HEAD ZINC	F81004-12	1	
41	BOLT, M12 X 35-8.8-FE/ZN5 HEX HEAD FULL	F81004-24	1	
42	NUT, M5-8-FE/ZN5 DIN985	F81030-2	2	
43	NUT, M12-8 HEX NYLON ZINC LOCK	F81034-2	1	
44	HOSE, DN12 W/FITTINGS PN10AOL90 I PN10AOL M1.5	096964	1	
45	HOSE PROTECTION	098489	1	
46	WASHER, 5.3 FLAT ZINC	F81052-1	4	
47	WASHER, 13 FLAT ZINC	F81056-1	3	
48	WASHER, Z12.2 SPLIT LOCK ZINC	F81056-2	2	
49	MAGNET, MW.38X12/N38 NEODYMIUM	500022	1	

3.4 Sawdust Flow Guide

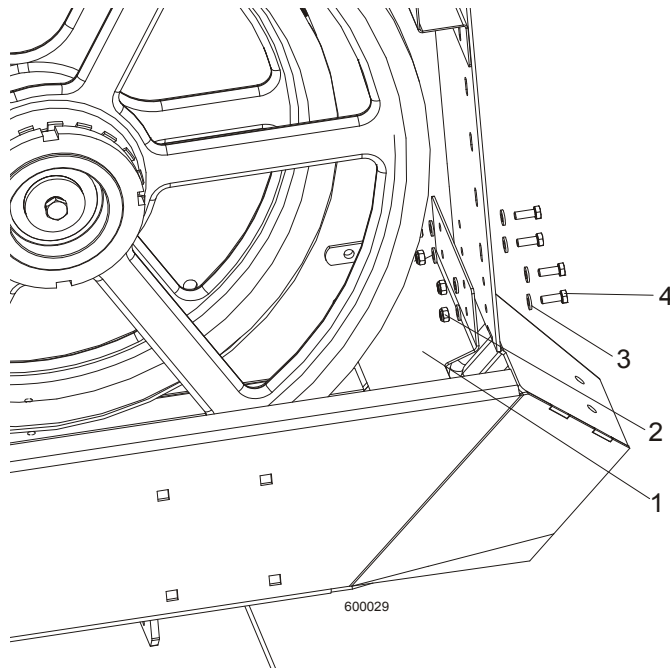

REF	DESCRIPTION (◆ Indicates Parts Available In Assemblies Only)	PART #	QTY.
1	GUIDE, SAWDUST FLOW PAINTED	090506	1
2	NUT, M6-8-B HEX NYLON ZINC LOCK	F81031-2	4
3	WASHER 6.4 ZINC FLAT	F81053-1	8
4	BOLT, M6 X 16 8.8 FE/ZN5 PN-M/82105	F81001-15	4

SECTION 4 SAW HEAD

4.1 Middle Throat Screw

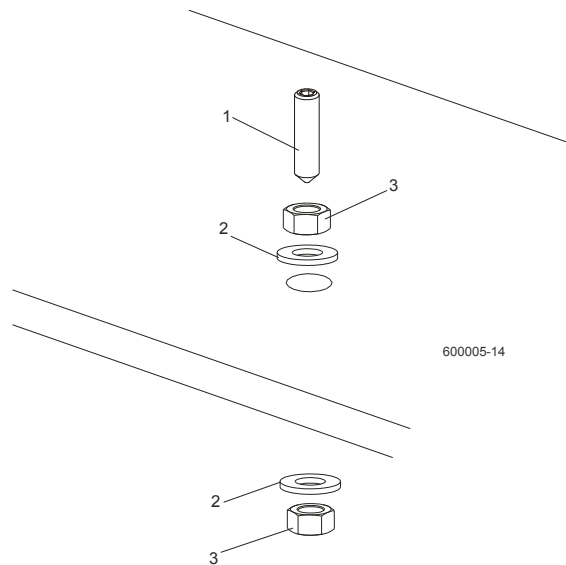

REF	DESCRIPTION (◆ Indicates Parts Available In Assemblies Only)	PART #	QTY.	
1	SCREW, M10X40-45H HEX SOCKET SET CONE POINT ZINC	F81003-61	1	
2	WASHER, 10.5 ZINC FLAT	F81055-1	2	
3	NUT, M10-8-B ZINC HEX	F81033-3	2	

4.2 Drive Belt Tensioner LT70 AC

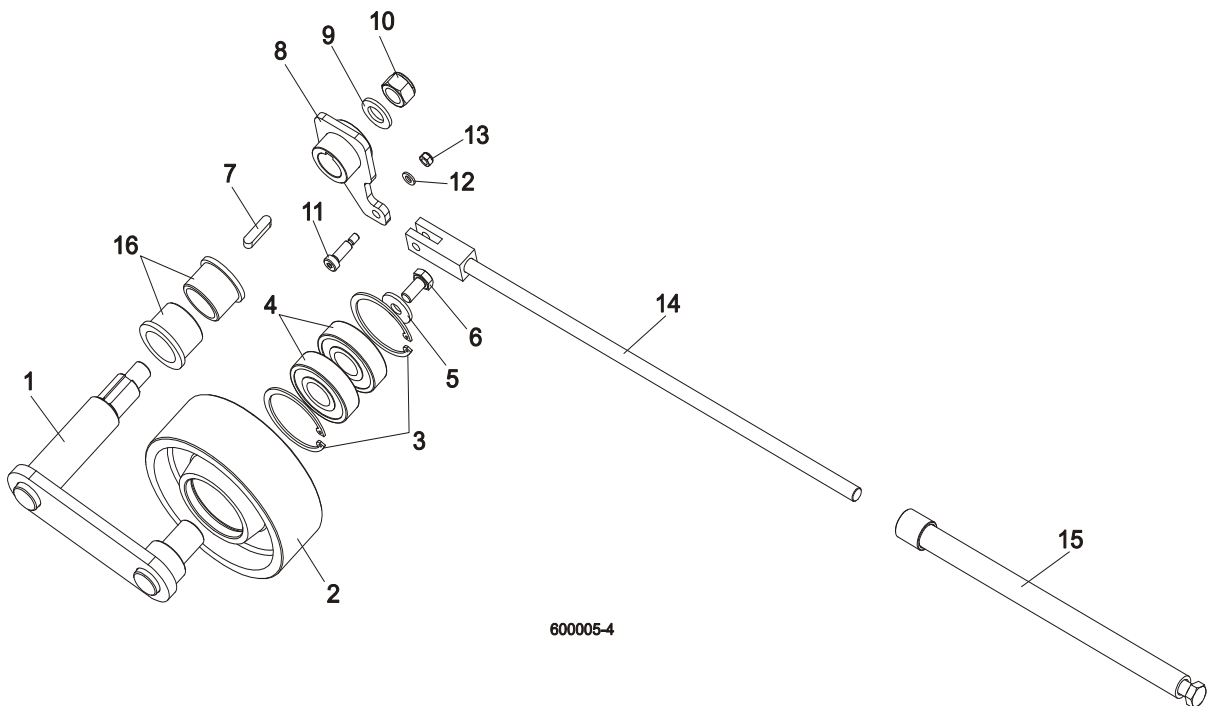

REF	DESCRIPTION (◆ Indicates Parts Available In Assemblies Only)	PART #	QTY.	
	TENSIONER ASSEMBLY, DRIVE BELT	508761	1	
1	Pivot Weldment, Drive Belt Tensioner	509885-1	1	

SAW HEAD

Board Return Assembly (Optional)

2	Wheel, Belt Tension	508762	1	
3	Ring, 62 mm Inside Spring Retaining	F81090-1	2	
4	Bearing, 6305 2RS NSK	P08066	2	
5	Washer, 11 Dia. Zinc Flat Special	088787-1	1	
6	Bolt, M10x20-5.8 Hex Head Full Thread Zinc	F81003-1	1	
7	Key, A8X7X32 Parallel	088564	1	
8	Arm Weldment, Drive Belt Tensioner	088807-1	1	
9	Washer, 17 Zinc Flat	F81058-1	1	
10	Nut, M16-5.8 Zinc Hex	F81036-2	1	
11	Bolt, 8/M6X20 12.9 ISO 7379 BOSSARD	F81001-25	1	
12	Washer 6.4 Zinc Flat	F81053-1	1	
13	Nut, M6-8-B Hex Nylon Zinc Lock	F81031-2	1	
14	Rod Weldment, Threaded Zinc-Plated	088789-1	1	
15	Tube Weldment, Threaded Zinc-Plated	088782-1	1	
16	BUSHING, MFM-3240-30	088461	2	

4.3 Board Return Assembly (Optional)

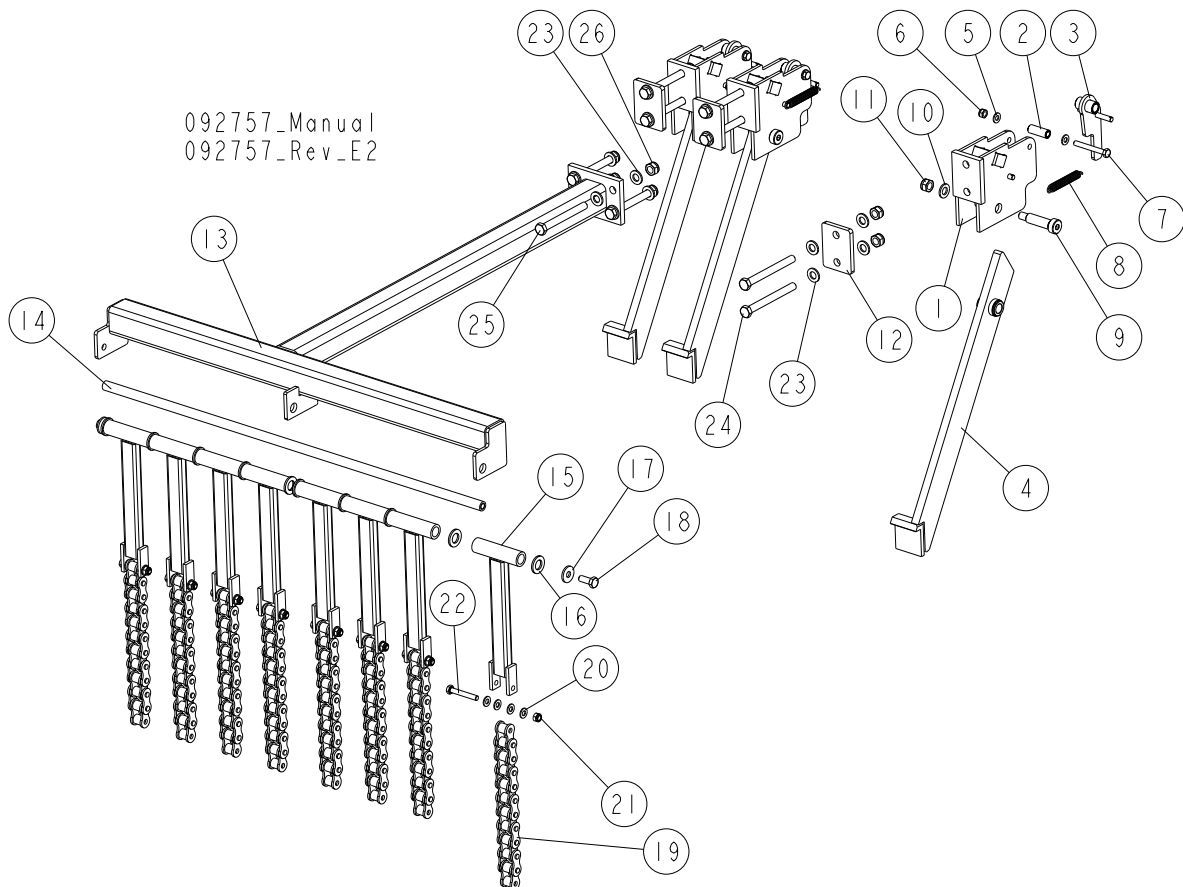

	DESCRIPTION (* Indicates Parts Available In Assemblies Only)	PART #	QTY	
	BOARD RETURN ASSEMBLY	092757	1	
	BOARD, RETURN ASSEMBLY	090120	3	
1	MOUNT WELDMENT, BOARD RETURN ARM	090109-1	1	

	DESCRIPTION (* Indicates Parts Available In Assemblies Only)	PART #	QTY	
2	SPACER, ZINC	090115-1	1	
3	LATCH WELDMENT, BOARD RETURN ARM	090118-1	1	
4	ARM, BOARD RETURN	090112-1	1	
5	WASHER, 8.4 FLAT ZINC	F81054-1	2	
6	NUT, M8-8-B HEX NYLON ZINC LOCK	F81032-2	1	
7	BOLT, M8 X 65MM,HH,GRADE 5.8, ZINC	F81002-3	1	
8	SPRING, EXT 1/2X2 1/4X.06	014817	2	
9	BOLT, 16/M12X50-12.9 ISO7379-BOSSARD SOCKET HEAD	F81004-25	1	
10	WASHER, 13 FLAT ZINC	F81056-1	1	
11	NUT, M12-8 HEX NYLON ZINC LOCK	F81034-2	1	
12	WASHER, SPECIAL	092756-1	3	
	GUIDE, BOARD RETURN	514162	1	
13	GUIDE WELDMENT, BOARD RETURN	091067-1	1	
14	ROD, BOARD RETURN GUIDE	091074	1	
15	BAR WELDMENT, BOARD GUIDE UPPER	091070-1	8	
16	WASHER, 17 FLAT ZINC	F81058-1	10	
17	WASHER,10.5 ZINC FLAT SPECIAL	F81055-6	2	
18	BOLT, M10 X 25 8.8 FE/ZN5, PN-M/82105	F81003-31	2	
19	CHAIN 16B-1 - 0.28M	514163	8	
20	WASHER, 8.4 FLAT ZINC	F81054-1	32	
21	NUT, M8-8-B HEX NYLON ZINC LOCK	F81032-2	8	
22	BOLT, M8 X 55 8.8 FE/ZN5, PN-M/82101	F81002-8	8	
23	WASHER, 13 FLAT ZINC	F81056-1	20	
24	BOLT M12X120 8.8 FE/ZN5	F81004-38	6	
25	BOLT,M12X110-8.8-B-FE/ZN5 PN-85/M82101	F81004-47	4	
26	NUT, M12-8 HEX NYLON ZINC LOCK	F81034-2	10	

4 SAW HEAD

Water Lube Assembly

4.4 Water Lube Assembly

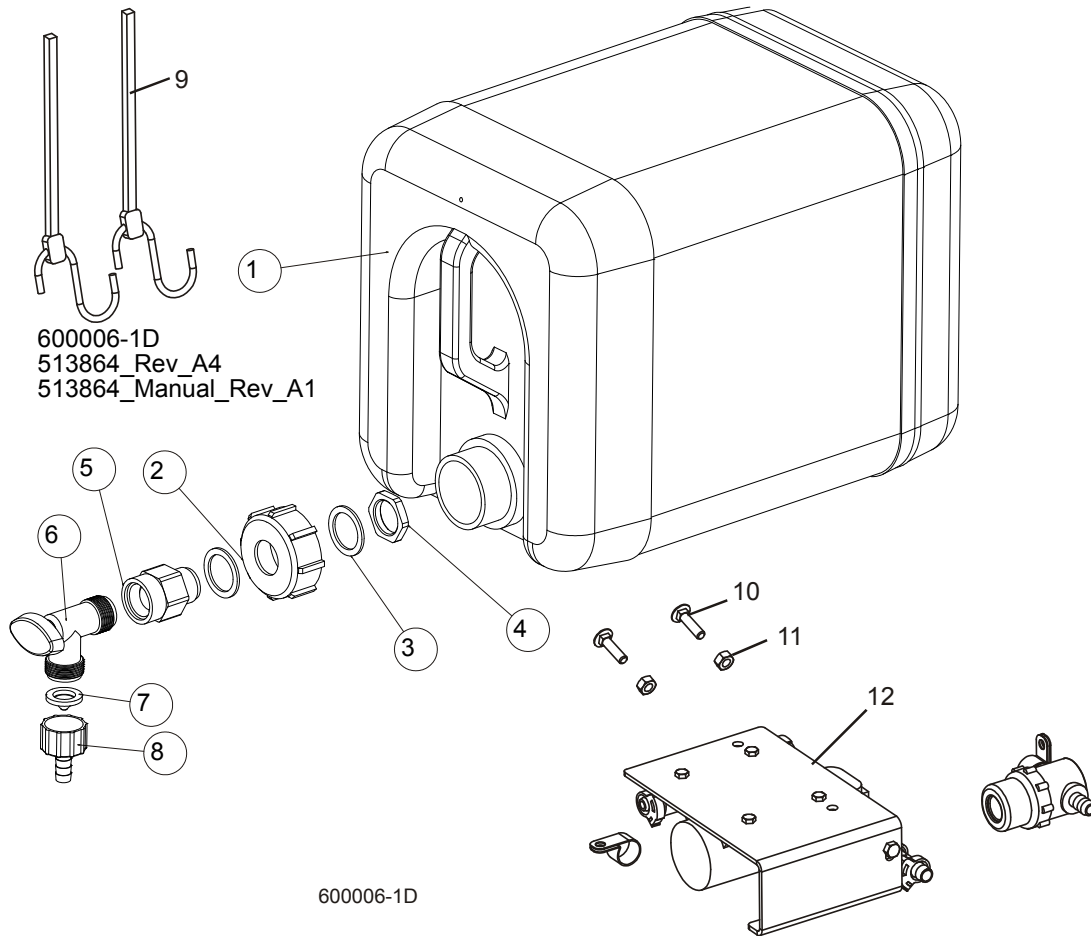

REF	DESCRIPTION (◆ Indicates Parts Available In Assemblies Only)	PART #	QTY.
	BOTTLE, WATER, COMPLETE.	513864	1
	BOTTLE, WATER, WITH NUT.	513865¹	1
1	BOTTLE, WATER	513866	1
2	NUT, BOTTLE.	513867	1
3	SEAL, RUBBER 35x26x2.	513869	2
4	NUT, PACKING 3/4 NPT.	513868	1
5	Fitting, 3/4FPT x 3/4MPT Reducer	014636	1
6	Fitting, Water Lube Shutoff Valve	014100	1
7	Filtr NUT	016086	1
8	FITTING, 5/8" NPT TO 3/8" HOSE BARB	014113	1
9	STRAP, 20" RUBBER	P11668	2
10	BOLT, 1/4-20 X 1" CARRIAGE HEAD	F05005-34	2
11	NUT, 1/4-20 HEX LOCK	F05010-21	2
12	LUBEMIZER PARTS/HOSES (SEE LUBEMIZER OPTION MANUAL)		

¹ The service number 513865-S includes: 513865, 513869, 513868

4.5 LT70AC Saw Head Decals

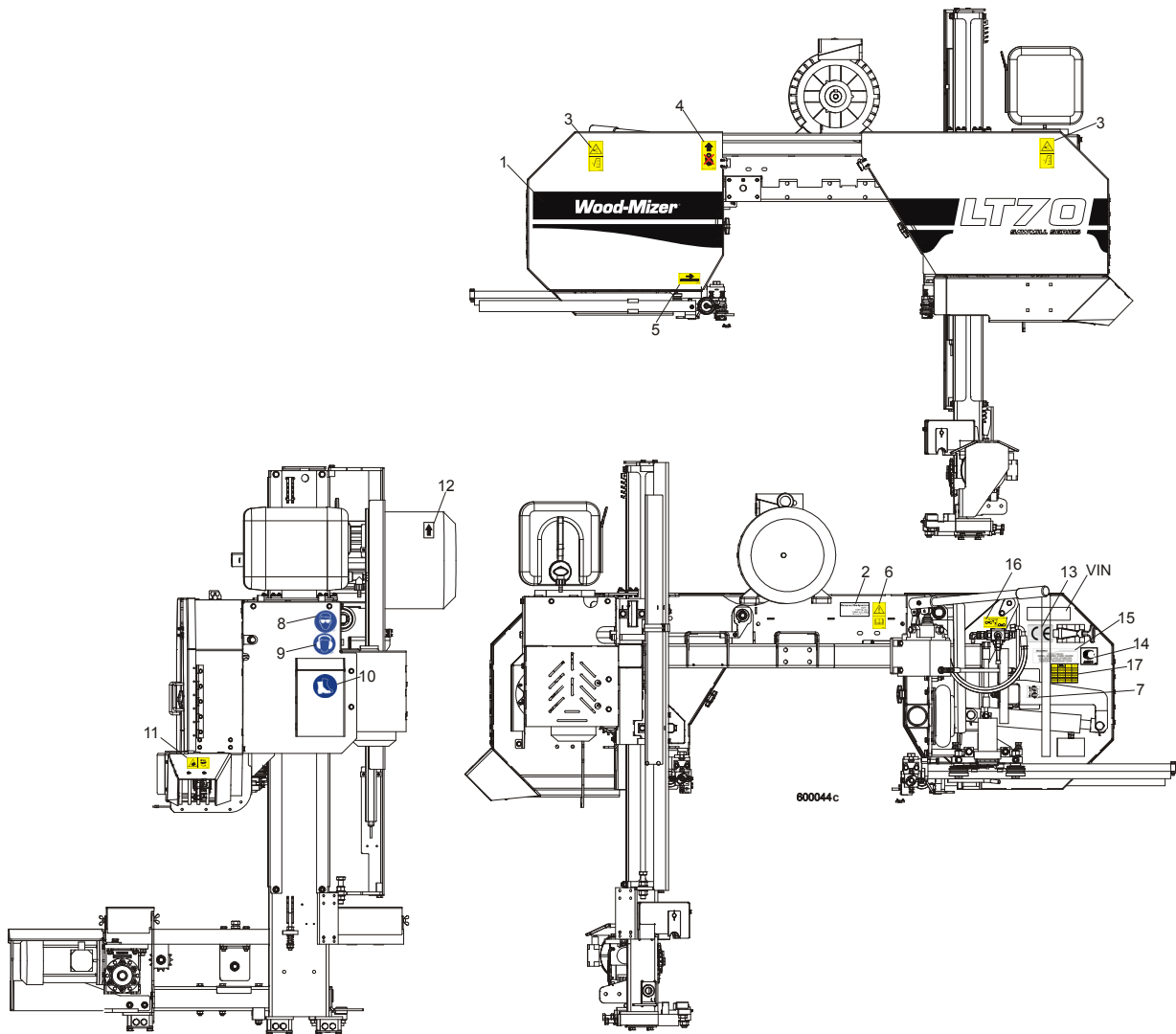

REF	DESCRIPTION (◆ Indicates Parts Available In Assemblies Only)	PART #	QTY.
1	DECAL, LT70 SERIES SAWMILL	092764	1
	PICTOGRAPHIC DECAL KIT, LT70AC	099518	1
2	DECAL, EUROPEAN HEADQUARTERS ADDRESS	015841	1
3	DECAL, SAWMILL COVERS CAUTION (PICTOGRAM)	099220	2
4	DECAL, PICTOGRAM (BLACK ARROW & HOOK)	085977B	1
5	DECAL, BLADE MOVEMENT DIRECTION (PICTOGRAM)	096321	1
6	DECAL, READ OPERATOR'S MANUAL (PICTOGRAM)	096317	1
7	DECAL, BLADE ALIGNMENT (PICTOGRAM)	P11789-70	1
8	DECAL, EYE PROTECTION WARNING (PICTOGRAM)	S12004G	1
9	DECAL, EAR PROTECTION WARNING (PICTOGRAM)	S12005G	1
10	DECAL, USE SAFETY BOOTS (PICTOGRAM)	501465	1
11	DECAL, SAWDUST CHUTE WARNING (PICTOGRAM)	099222	1
12	DECAL, MOTOR ROTATION DIRECTION	S20097	1
13	DECAL, CE CERTIFIED SAWMILL	P85070	2
14	DECAL, RUSSIAN SAFETY CERTIFICATION	099401	1

4**SAW HEAD***LT70AC Saw Head Decals*

15	DECAL, INTERNATIONAL SAWMILL NAME	501466	1	
16	DECAL, LEVER OF TENSIONER'S BALL VALVE	505189	1	
17	DECAL, BLADE TENSION VALUES	518439	1	
	DECAL, HIGH VOLTAGE INSIDE THE ELECTRIC BOX (PICTOGRAM)	096316	2	
	DECAL, REMOVE THE PLUG BEFORE OPENING THE BOX (PICTOGRAM)	096319	2	
	DECAL, STAY A SAFE DISTANCE FROM THE BLADE (FOR DEBARKERS)	098176	1	
	DECAL, BLADE SETTING	P85066-70	1	
	DECAL, KEEP AWAY DANGER, PICTOGRAM	099221	1	
	DECAL, MAX. OIL PRESSURE, PICTOGRAM	099524	1	

4.6 Blade Housing Covers

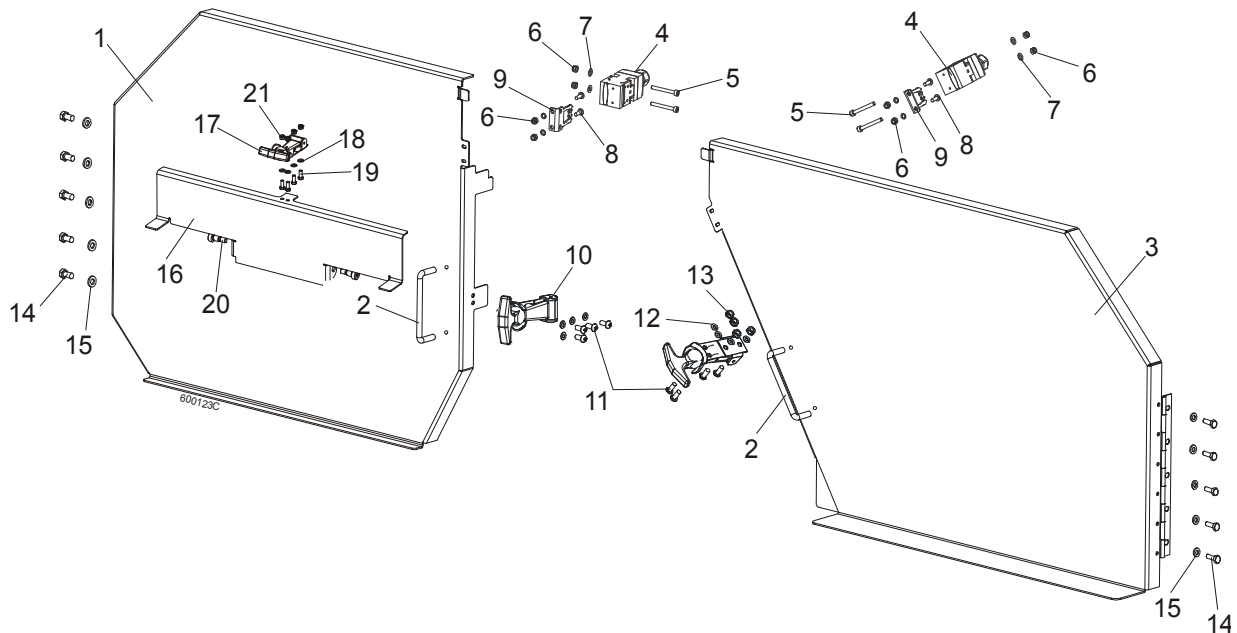

REF	DESCRIPTION (◆ Indicates Parts Available In Assemblies Only)	PART #	QTY.
	COVER ASSEMBLY, IDLE SIDE BLADE HOUSING	088920	1
1	Cover Assembly, Idle Side Blade Housing, Ptd	088915-1	1
2	Handle, Blade Housing Cover	P08065	1
	COVER ASSEMBLY, DRIVE SIDE BLADE HOUSING	088921	1
3	Cover Assembly, Drive Side Blade Housing, Ptd	088917-1	1
2	Handle, Blade Housing Cover	P08065	1
4	SAFETY SWITCH, AZ17-11ZRK	094232	2
5	BOLT, M4 X 35-8.8 SOCKET HEAD	F81011-34	4
6	NUT, M4-B HEX NYLON ZIN	F81028-2	8
7	WASHER 4,3 ZINC, FLAT	F81051-2	8
8	SCREW, M4 X 12-5.8	F81011-41	4
9	KEY, AZ17/170-B5 SAFETY SWITCH	094422	4
10	LATCH, FLEXIBLE DRAW	014829	2
11	BOLT, M5X12-5.8	F81000-5	8
12	WASHER 5,3 ZINC FLAT	F81052-1	8
13	NUT M5-8 DIN 985 ZINC	F81030-2	8
14	BOLT, M6X16 8.8 HEX HEAD FULL THREAD ZINC	F81001-15	10
15	WASHER 6.4 ZINC FLAT	F81053-1	10
	COVER BLADE UP LT70, COMPLETE	511536¹	1
16	PLATE UP COVER LT70, PAINTED	511802-1	1
17	Latch, Flexible Draw	014829	1
18	WASHER 5.3 FE/ZN5 PN-78/M-82005	F81052-1	2
19	BOLT, M5 X 12-5.8-Fe/Zn5, PN-M/82105	F81000-5	4
20	BOLT, 10/M8 X 12-12.9 ISO-7379	F81003-62	2
21	NUT, M5-8-Fe/Zn5 DIN985	F81030-2	2

¹ Belongs to 088771 and 88770

4.7 Sawdust Chute

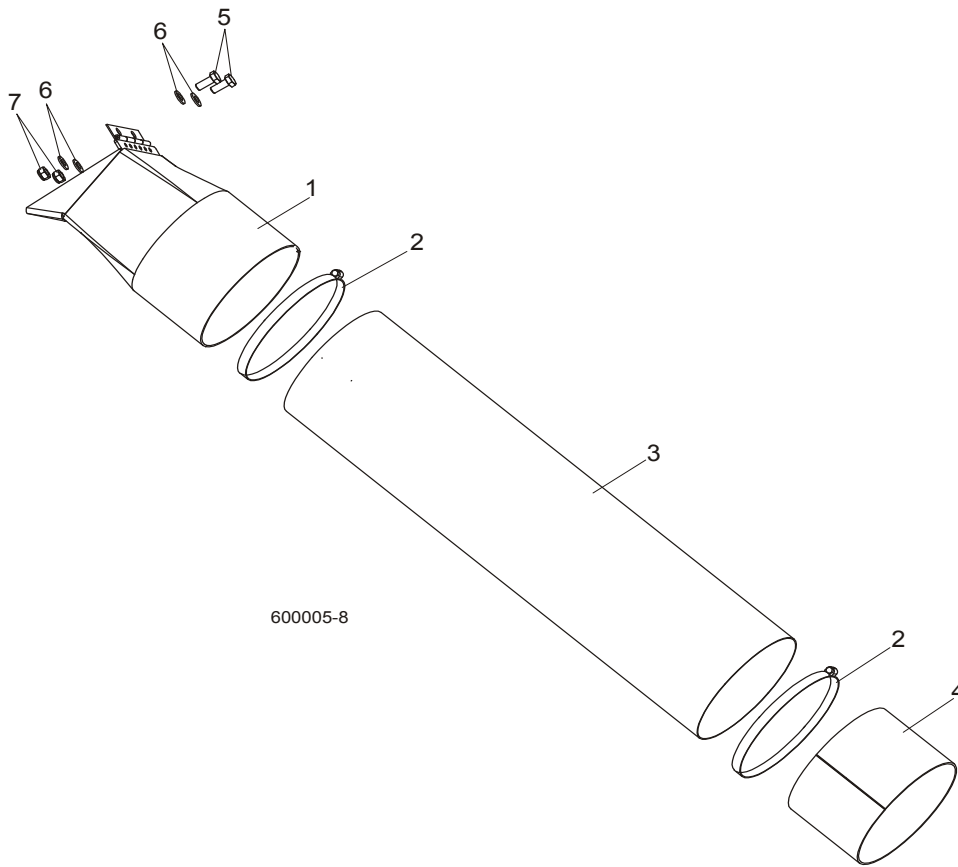

REF	DESCRIPTION (◆ Indicates Parts Available In Assemblies Only)	PART #	QTY.
1	CHUTE WELDMENT, SAWDUST	089352-1	1
2	CLAMP, 152 MM	089358	2
3	TUBE, SAWDUST CHUTE	090153	1
4	TUBE, CHUTE END	090126-1	1
5	BOLT, M8X20-8.8-B HEX HEAD FULL THREAD ZINC	F81002-4	2
6	WASHER 8.4 ZINC FLAT	F81054-1	4
7	NUT, M8-8-B HEX NYLON ZINC LOCK	F81032-2	2

4.8 Saw Head Protection Kit, LT70M Mobile

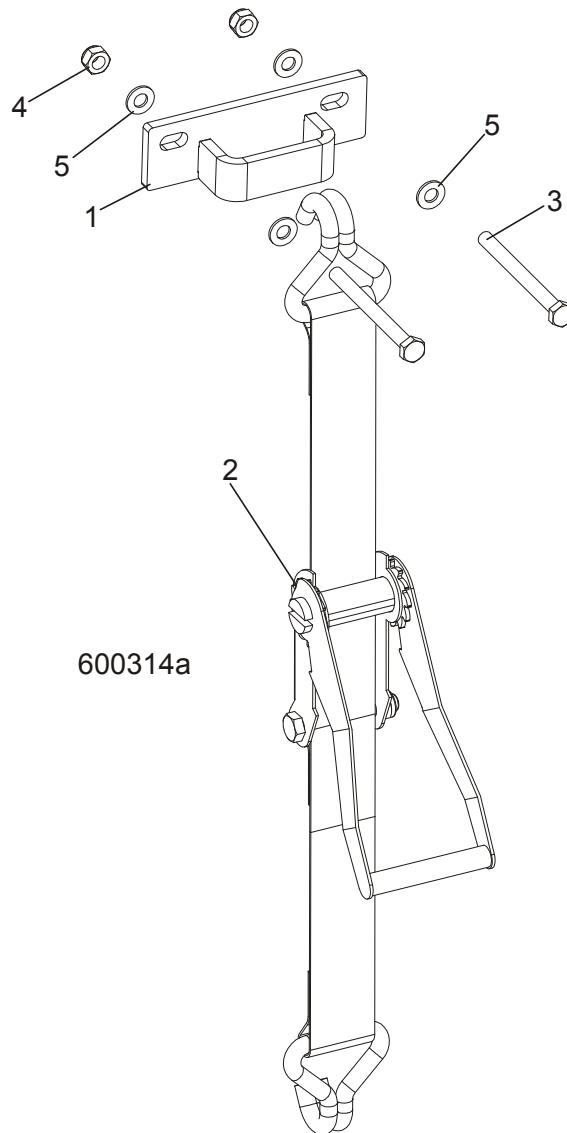

REF	DESCRIPTION (◆ Indicates Parts Available In Assemblies Only)	PART #	QTY.
	SAW HEAD PROTECTION KIT, LT70M MOBILE	505564	1
1	BRACKET, PROTECTION BELT	505364-1	1
2	BELT, LT70 SAW HEAD PROTECTION	505563	1
3	BOLT, M10x75-8.8-Fe/Zn5 PN-M/82101	F81003-15	2
4	NUT, M10-8-B NYLON HEX ZINC LOCK	F81033-1	2
5	WASHER, 10.5 FLAT ZINC	F81055-1	4

SECTION 5 CONTROL BOXES

5.1 Control Assembly, LT70 AH

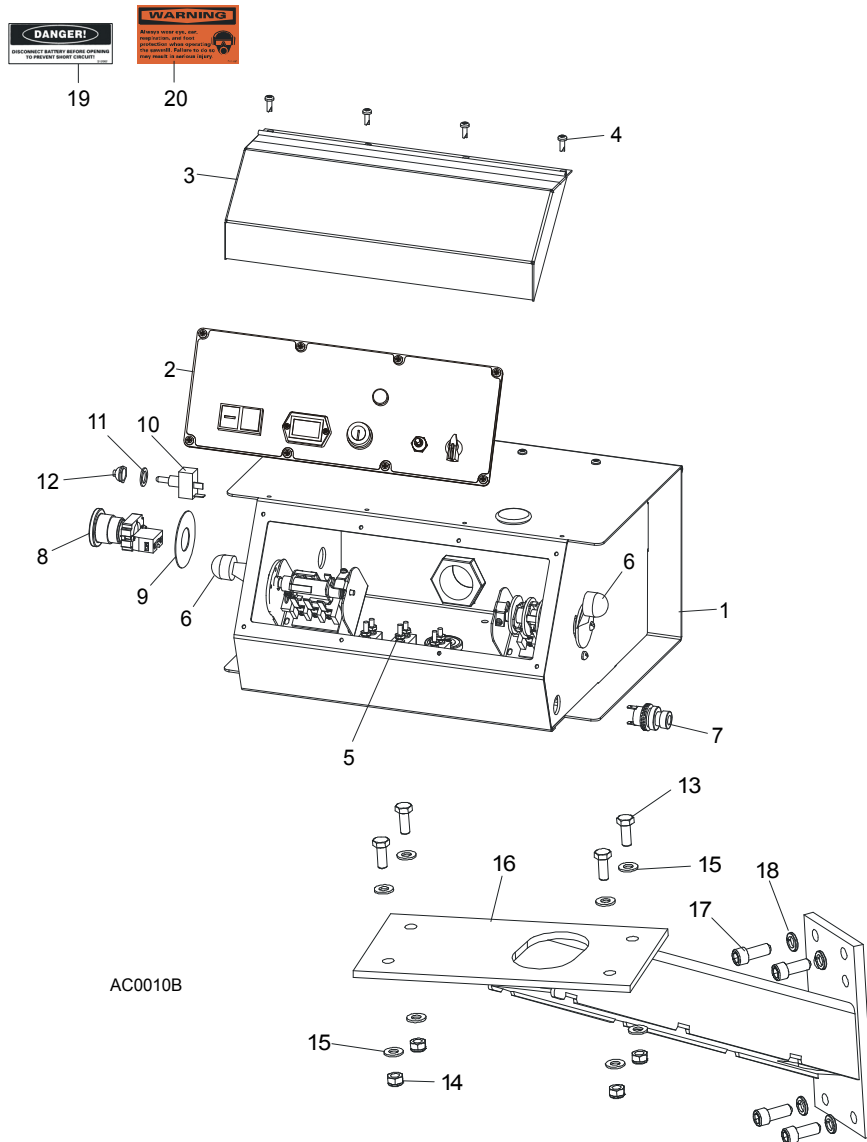

REF	DESCRIPTION (◆ Indicates Parts Available In Assemblies Only)	PART #	QTY.	
	CONTROL BOX ASSEMBLY, AC SUPER (EA20, EA25)	093022	1	
1	HOUSING, AC SUPER CONTROL BOX ASSEMBLY (EA20, EA25)	086546-1	1	◆
2	Front Control Panel & Wiring Harnesses (Section 5.4)			
3	Cover, Control Box Hinged	015304	1	
4	Screw, #10-24 x 1/2"	F05015-17	12	
5	Circuit Breakers (Section 5.3)			
6	Drum Switches (Section 5.2)			
7	Switch, Horn	E85118	1	
8	Switch, XB2 BS542 Emergency Stop	086556	1	
9	Washer, Emergency Stop Switch	086561	1	
10	Switch, Speed Control	086773	1	

11	Washer, 1/2" x 3/4" x 5/8" Nylon	P05251-1	1	
12	Boot, Speed Control Switch	P02575	1	
13	BOLT, M8 X 20-8.8-B HEX HEAD	F81002-4	4	
14	NUT, M8-8-B HEX	F81032-2	4	
15	WASHER, 8.4 FLAT	F81054-1	8	
16	MOUNT WELDMENT, STANDARD CONTROL BOX	086732-1	1	
17	BOLT,, 3/8-16 X 1" SOCKET HEAD	F05007-52	4	
18	WASHER, 10.2 SPLIT LOCK	F81055-2	4	
19	DECAL, FRONT OUTRIGGER WARNING	015400-4	1	
20	DECAL, EAR/EYE PROTECTION WARNING	S11753-4	1	

5.2 Drum Switches

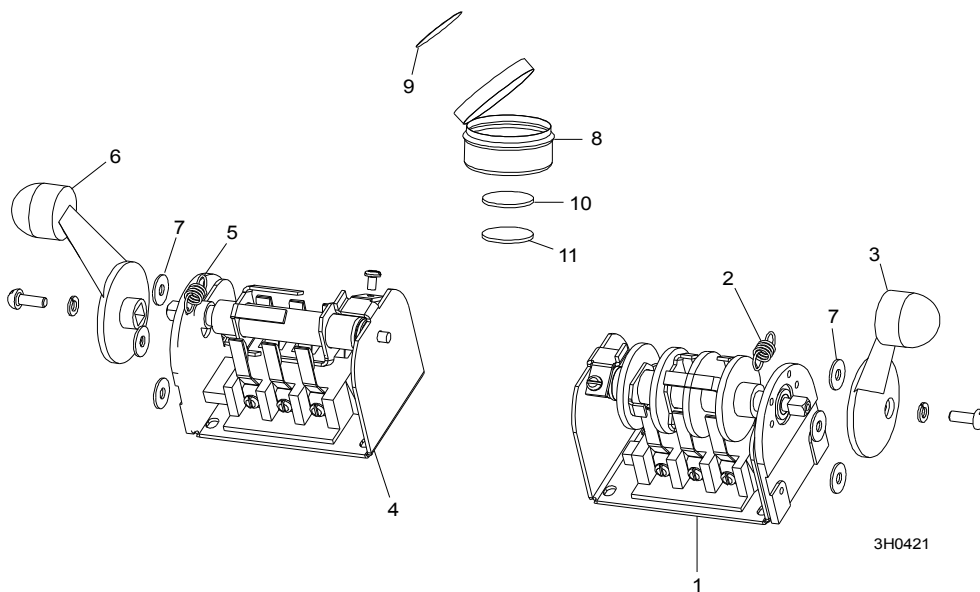

REF	DESCRIPTION (◆ Indicates Parts Available In Assemblies Only)	PART #	QTY.	
	SWITCH ASSEMBLY, UP/DOWN DRUM	E20440	1	
1	Switch, S12 Bulk Drum	E20440-B	1	◆
2	Spring, Drum Switch	P12570	1	
3	Handle, Drum Switch Replacement	P12500	1	
	SWITCH ASSEMBLY, POWER FEED DRUM	E20438	1	
4	Switch, S10 Bulk Drum	E20438-B	1	◆
5	Spring, Drum Switch	P12570	1	
6	Handle, Drum Switch Replacement	P12500	1	
7	WASHER, #8 SAE FLAT	F05011-41	6	
	CUP ASSEMBLY, DRUM SWITCH GREASE	A20463	1	
8	Cup, Plastic Container	P20464	1	◆
9	Decal, Grease Cup Label	P20467	1	
10	Pad, Velcro Loop	P20466	1	◆
11	Pad, Velcro Hook	P20465	1	◆
	Grease, High Temp Drum Switch	P20468	.011ml	◆

5.3 Circuit Breakers

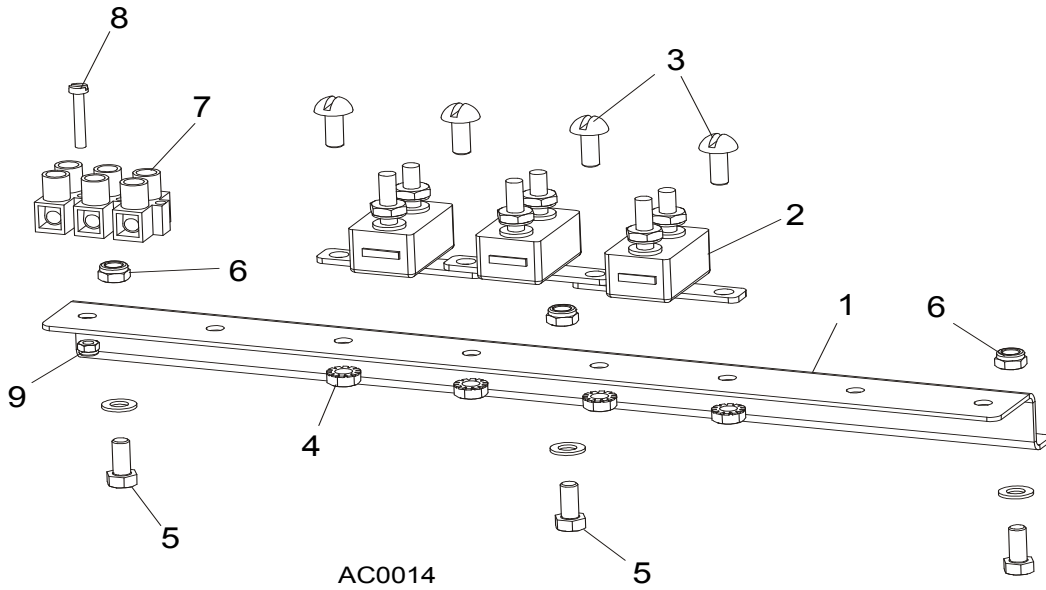

REF	DESCRIPTION (◆ Indicates Parts Available In Assemblies Only)	PART #	QTY.
	BREAKER ASSEMBLY, SAWMILL CONTROL CIRCUIT	015621	1
1	Rail, Circuit Breaker	015310	1
2	Breaker, 15 Amp Manual Reset	E20430	5
3	Screw, #8-32 X 1/2" Slotted Head	F05004-12	6
4	Nut, #8-32 Hex Self-Locking	F05010-41	6
5	BREAKER, 70 AMP MANUAL RESET PANEL MOUNT	015527	1
6	BREAKER, 50 AMP MANUAL RESET PANEL MOUNT	021256	1
7	BOOT, CIRCUIT BREAKER	021253	2
8	SCREW, #10-24 X 3/8" PHILLIPS PAN HEAD	F05004-3	3
9	NUT, #10-24 SELF LOCKING	F05010-14	3

5.4 Front Panel Assembly & Harnesses

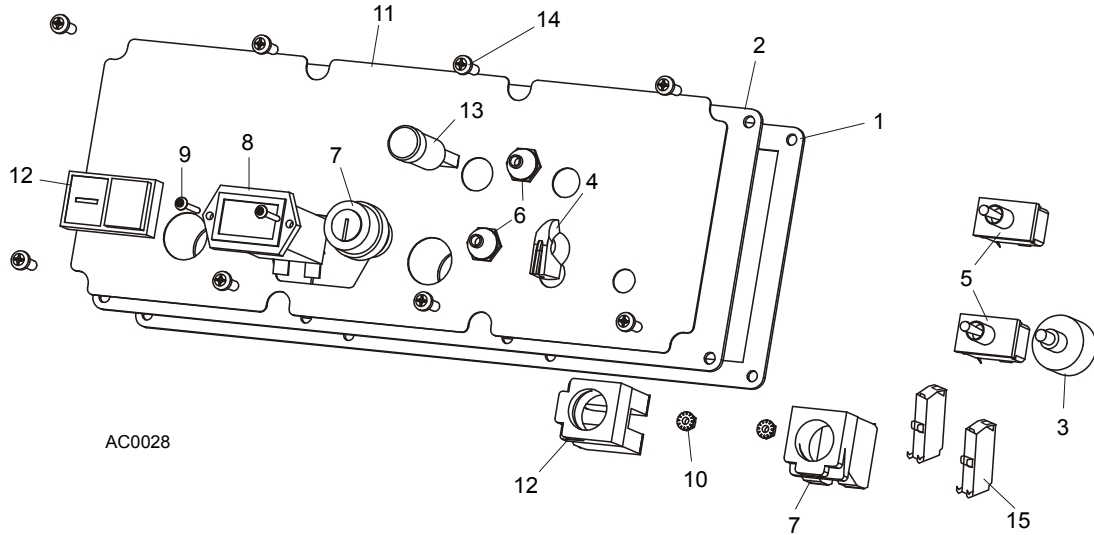

REF	DESCRIPTION (◆ Indicates Parts Available In Assemblies Only)	PART #	QTY.
	PANEL ASSEMBLY, AC SUPER CONTROL FRONT (EA20, EA25)	087387	1
1	Gasket, Front Panel	088387	1
2	Panel Weldment, Control	087316	1
3	Switch Assembly, Feed Rate	E20519	1
4	Knob, Feed Rate With Set Screw	P06257	1
5	Switch, Toggle	024200	2
6	Boot, Toggle Switch Rubber	P02575	2
7	Switch, Key	087350	1
8	Meter, Hour	015401	1
9	Screw, 6-32 x 3/4" Socket Button Head Cap Stainless Steel	F05004-93	2
10	Nut, # 6-32 Keps	F05010-59	2
11	Decal, Control Pane	087351	1
12	Switch, START-STOP	087349	1
13	Lamp, Control	087348	1
	HARNES ASSEMBLY, UPPER WIRING	093167	1
14	Screw, #10-24 x 1/2" Pan Head	F05015-17	8

5.5 Solenoids

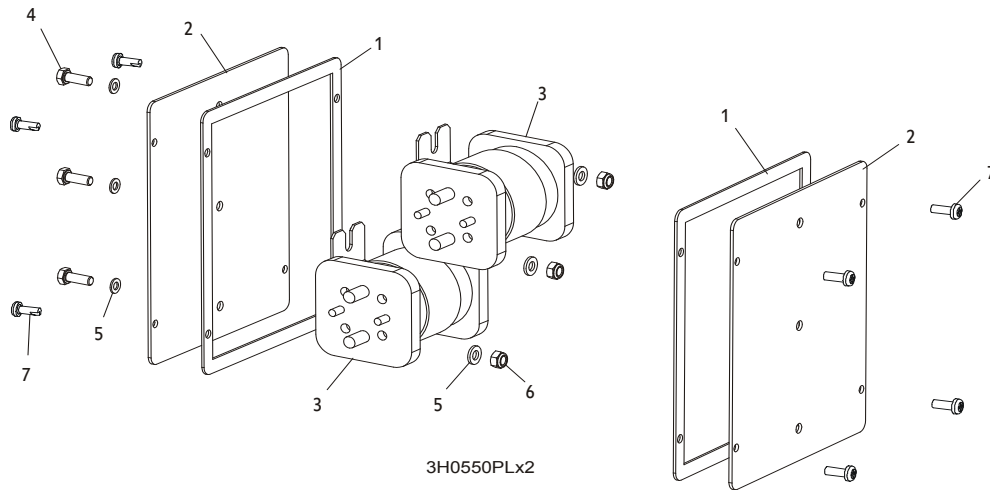

REF	DESCRIPTION (◆ Indicates Parts Available In Assemblies Only)	PART #	QTY.	
1	GASKET, SIDE PANEL	015274	2	
2	PANEL WELDMENT, SIDE	015307	2	
3	SOLENOID, 200A 12V SPST HYDRAULIC PUMP	015470	2	
4	BOLT, M6 X 16 8.8 FE/ZN5 PN-M/82105	F81001-15	3	
5	WASHER, 6.4 FLAT ZINC	F81053-1	6	
6	NUT, M6-8-B HEX NYLON ZINC LOCK	F81031-2	3	
	DIODE ASSEMBLY, SOLENOID COIL CHASSIS GND	087496	4	
7	BOLT, #10-24 X 1/2 PHILLIPS PAN HEAD TYPE 23	F05015-17	8	

SECTION 6 UP/DOWN SYSTEM

6.1 Up/Down Rollers & Covers

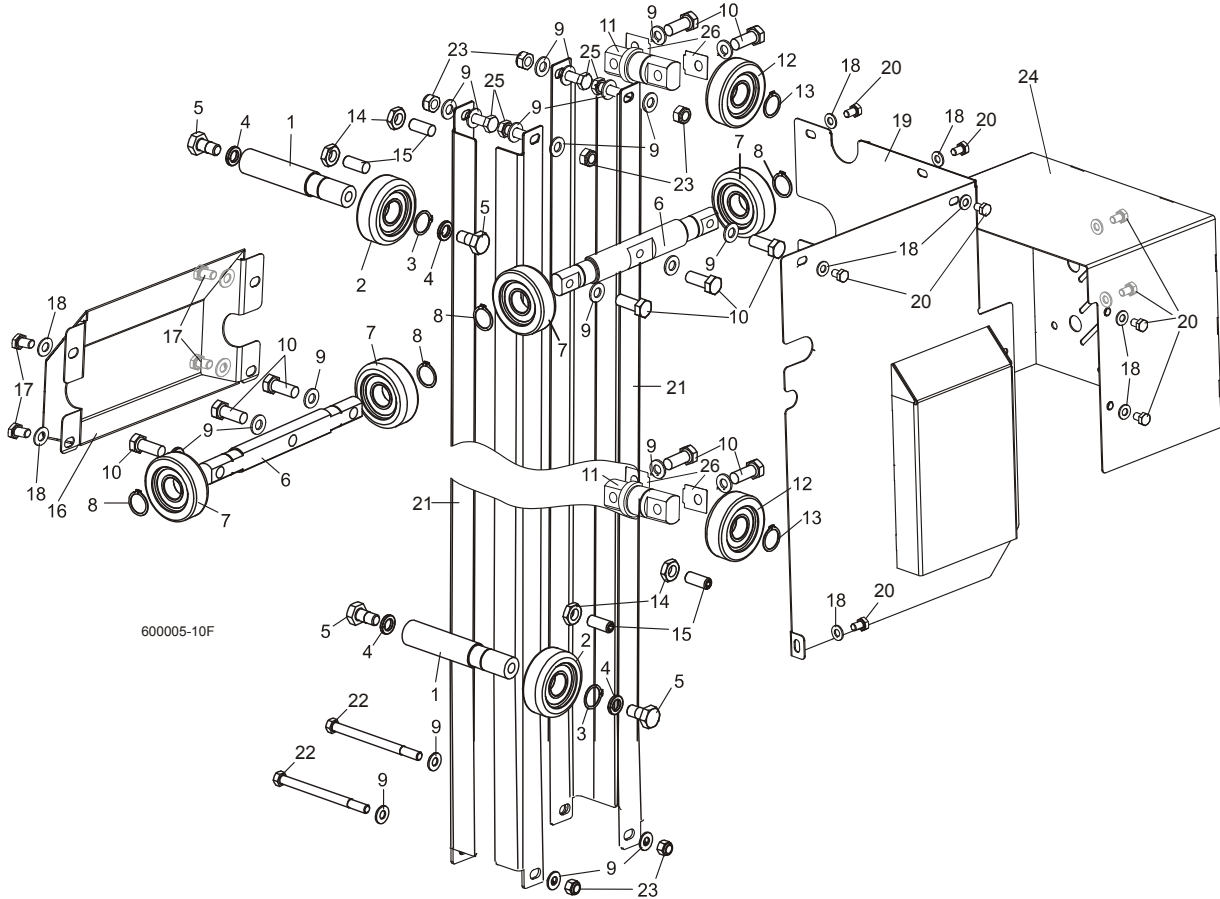

REF	DESCRIPTION (◆ Indicates Parts Available In Assemblies Only)	PART #	QTY.
	ROLLER ASSEMBLY, INSIDE UP/DOWN	089456	2
1	Shaft, Inside Up/Down Roller	088817-1	1
2	Bearing, CBK-468 Rolling	088433	1
3	Ring, Z30 Spring Retaining	F81090-23	1
4	Washer, 13 Zinc Flat	F81056-1	2
5	Bolt, M12x25-8.8 Hex Head Full Thread Zinc	F81004-31	2
	ROLLER ASSEMBLY, OUTSIDE UP/DOWN	089454	2
6	Shaft, Long Up/Down Roller	088815-1	1
7	Bearing, CBK-468 Rolling	088433	2
8	Ring, Z30 Spring Retaining	F81090-23	2
9	Washer, 10.5 Zinc Flat	F81055-1	22
10	Bolt, M10x35-8.8 Hex Head Full Thread Zinc	F81003-17	10
	ROLLER ASSEMBLY, SHORT UP/DOWN	089455	2
11	Shaft, Short Up/Down Roller	088816-1	1
12	Bearing, CBK-468 Rolling	088433	1
13	Ring, Z30 Spring Retaining	F81090-23	1
14	NUT, M10-04-W HEX ZINC THIN	F81033-6	4
15	SCREW, GN 913.3-M10-40-MS SET	F81003-65	4
16	COVER WELDMENT, UP/DOWN ROLLER	507056-1	1

17	BOLT, M8X16-8.8-B HEX HEAD FULL THREAD ZINC	F81002-20	4	
18	WASHER, 8.4 ZINC FLAT	F81054-1	13	
19	GUARD WELDMENT, RA-08 UP/DOWN GEAR BOX SIDE PTD	091319-1	1	
20	BOLT, M8X12-8.8 HEX HEAD FULL THREAD ZINC	F81002-6	9	
21	ANGLE, MAST TUBE STAINLESS	088492	4	
22	BOLT, M10X125-8.8 HEX HEAD ZINC	F81003-18	2	
23	NUT, M10-8-B HEX NYLON ZINC LOCK	F81033-1	6	
24	GUARD, UP/DOWN MOTOR PAINTED	090501-1	1	
25	BOLT, M10X30-5.8 HEX HEAD FULL THREAD	F81003-2	4	
26	SPACER, ROLLER ASSEMBLY, SHORT UP/DOWN	510616	-	

6.2 Blade Height Scale

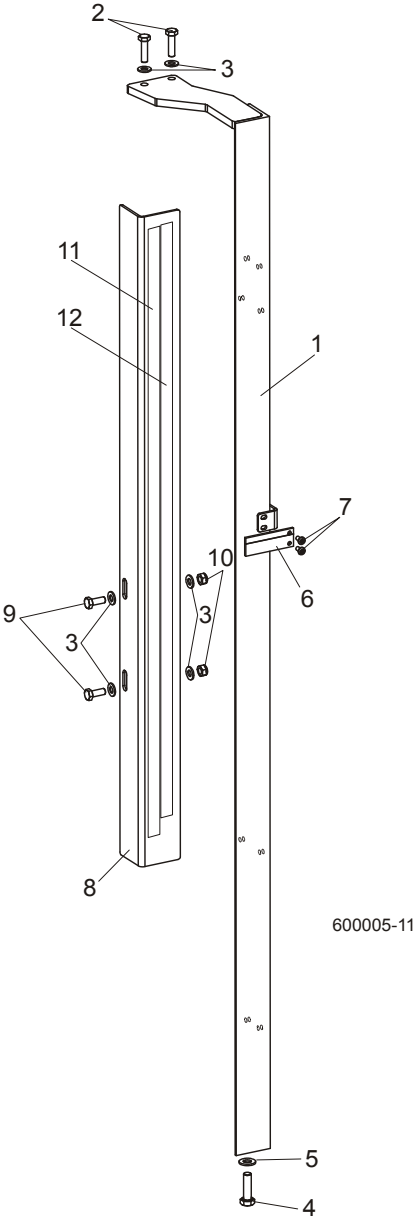

REF	DESCRIPTION (◆ Indicates Parts Available In Assemblies Only)	PART #	QTY.	
1	MOUNT WELDMENT, SCALE PAINTED	088554-1	1	
2	BOLT, M8 x 30-8.8-B HEX HEAD FULL THREAD ZINC	F81002-7	2	

6 Up/Down System

Up/Down Chain & Sprockets

3	WASHER, 8.4 ZINC FLAT	F81054-1	6	
4	BOLT, M10 x 35-8.8 HEX HEAD FULL THREAD ZINC	F81003-17	1	
5	WASHER, 10.5 ZINC FLAT	F81055-1	1	
6	INDICATOR, BLADE HEIGHT SCALE	094821	1	
7	SCREW, #10-24 X 3/8 PHILLIPS PAN HEAD ZINC	F05004-3	2	
8	ANGLE, SCALE MOUNT	088785-1	1	
9	BOLT, M8 X 20-8.8-B HEX HEAD FULL THREAD ZINC	F81002-4	2	
10	NUT, M8-8-B HEX NYLON ZINC LOCK	F81032-2	2	
11	DECAL, METRIC SCALE	S11711	1	
12	DECAL, 16-40 MM METRIC SCALE	P12040-1	1	

6.3 Up/Down Chain & Sprockets

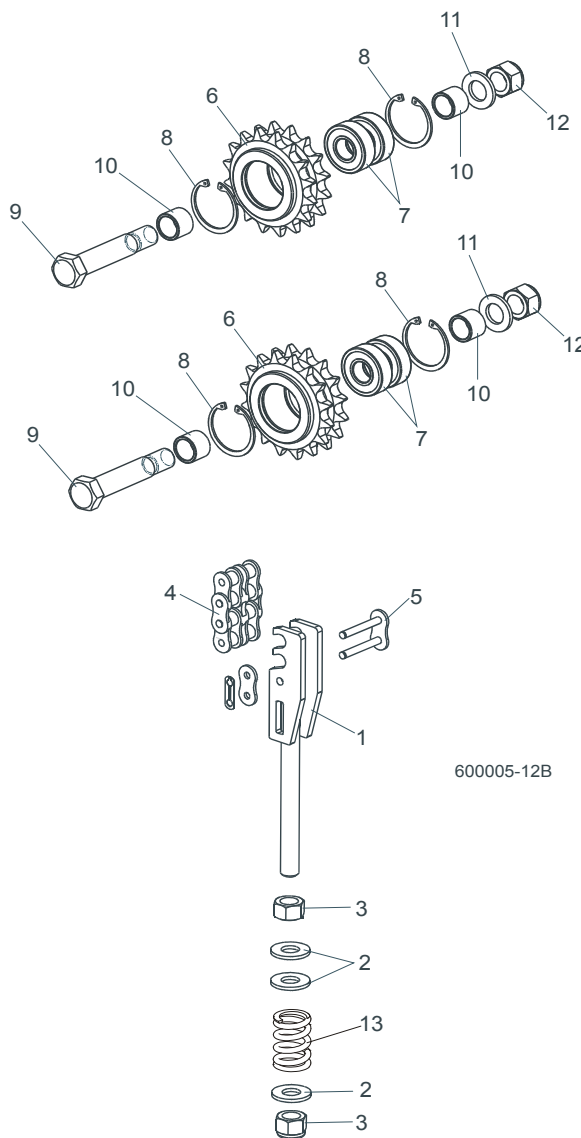

REF	DESCRIPTION (◆ Indicates Parts Available In Assemblies Only)	PART #	QTY.	
1	TENSIONER WELDMENT, UP/DOWN CHAIN ZINC	512181-1	1	
2	WASHER, 13 ZINC FLAT	F81056-1	3	
3	NUT, M12-8 HEX NYLON ZINC LOCK	F81034-2	2	
4	CHAIN, 12B-2 97-LINK	512197	1	

5	LINK, 12B-2Pz MASTER	099249	1	
	SPROCKET ASSEMBLY, UP/DOWN IDLER	512180	2	
6	Sprocket, Zinc-plated	512179-1	1	
7	Bearing, 6203-2RS FLT Rolling	086114	2	
8	Ring, W40 Spring Retaining	F81090-3	2	
9	Bolt, M16D1F6 x 90-8.8 Hex Fit Short Thread Zinc	F81006-15	1	
10	Spacer, Idler Zinc	088792-1	2	
11	Washer, 17 Zinc Flat	F81058-1	1	
12	Nut, M16-8 Hex Nylon Zinc Lock	F81036-2	1	
13	Spring, 14x30x3,2	090797	1	

6.4 Up/Down Drive Assembly

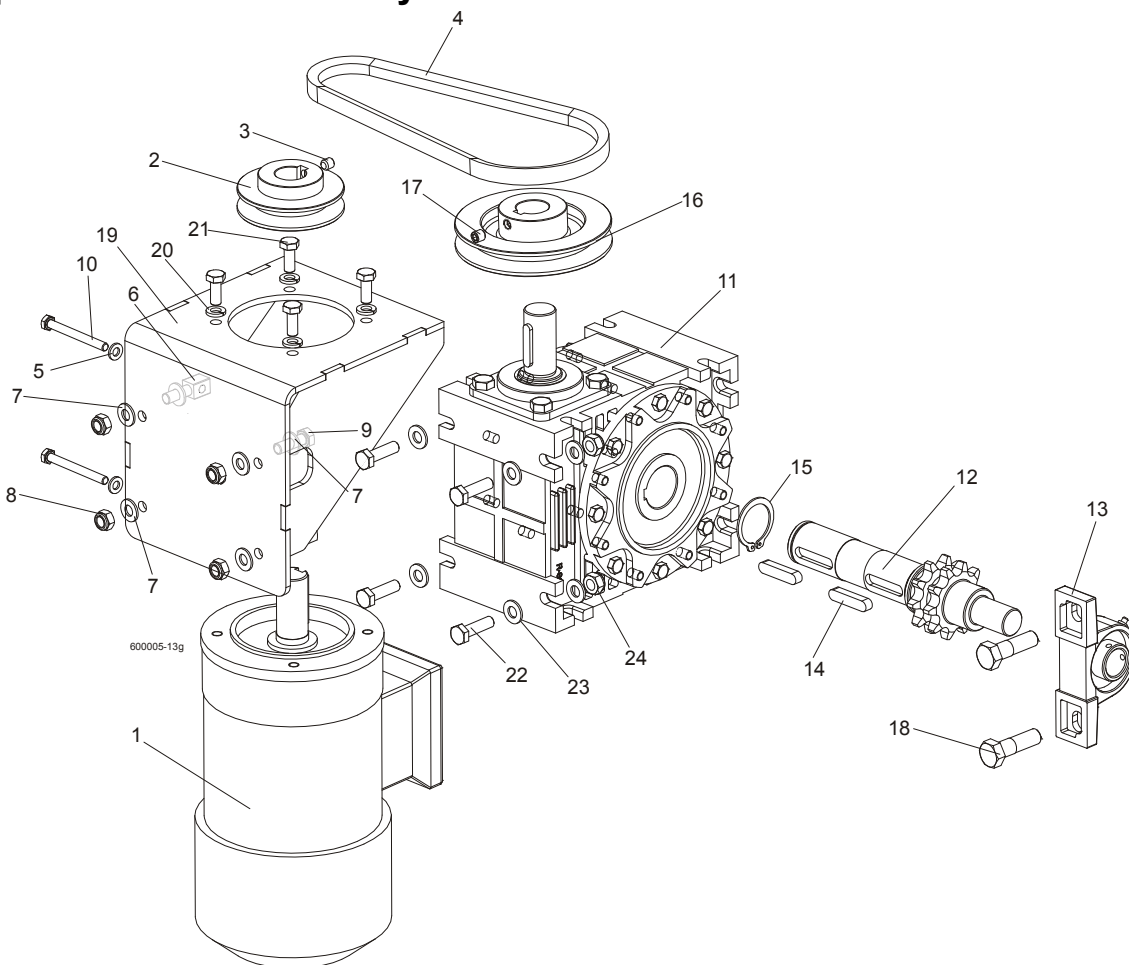

REF	DESCRIPTION (◆ Indicates Parts Available In Assemblies Only)	PART #	QTY.	
	MOTOR W/MOUNT BRACKET, AC UP/DOWN	090493	1	
1	AC Motor, 2 gear STKg90 6/4L2 IMB14/162	086530	1	
2	Pulley, AC Motor Painted	090497-1	1	
3	Screw, M8x8-33H Hex Socket Set Flat Point Zinc	F81014-1	1	
4	V-Belt, HA-670	091328	1	
5	Washer, 6.4 Zinc Flat	F81053-1	2	
6	Bolt, Special - Zinc Plated	088962-1	2	
7	Washer, 8.4 Zinc Flat	F81054-1	8	

8	Nut, M8-8-B Hex Nylon Zinc Lock	F81032-2	4	
9	Bolt, M8X25-8.8-B Hex Head Full Thread Zinc	F81002-5	2	
10	Bolt, M6x60-8.8 Hex Head Full Thread Zinc	F81001-9	2	
	GEAR BOX ASSEMBLY, UP/DOWN DRIVE	091310	1	
11	Gear Box, R80/64/WBS/D1,N+S,V5	097701	1	
12	Output Shaft W/Sprocket, Up/Down Drive	517320-1	1	
13	Bearing Assembly, UCP205 CX	088468	1	
14	KEY,. A10x8x45 PN-91/M-85005 PARALLEL	091312	1	
15	Ring, Outside Retaining Z38	F81090-26	1	
16	PULLEY, UP/DOWN GEAR PAINTED	091308-1	1	
17	SCREW, M8X8-33H HEX SOCKET SET FLAT POINT ZINC	F81014-1	1	
18	BOLT, M12 X 40-8.8 HEX HEAD ZINC	F81004-1	1	
19	BRACKET, AC UP/DOWN MOTOR MOUNT PTD	090494-1	1	
20	WASHER 8.2 SPLIT LOCK ZINC	F81054-4	4	
21	BOLT, M8 X 20-8.8-B HEX HEAD FULL THREAD ZINC	F81002-4	4	
22	BOLT M10x35-8.8 HEX HEAD FULL THREAD ZINC	F81003-17	4	
23	WASHER 10,5Fe/Zn5, SPECIAL	F81055-4	8	
24	NUT,M10-8-B NYLON HEX ZINC LOCK	F81033-1	4	

6.5 Safety Switches

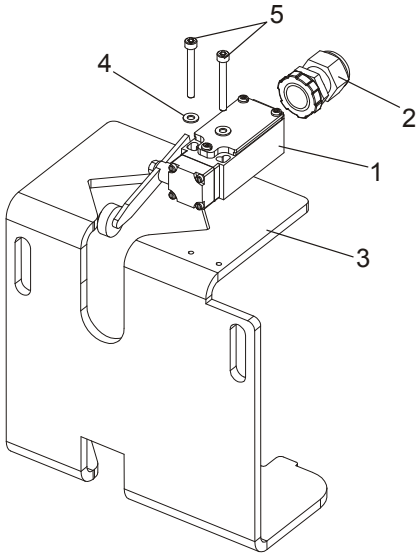

600045B

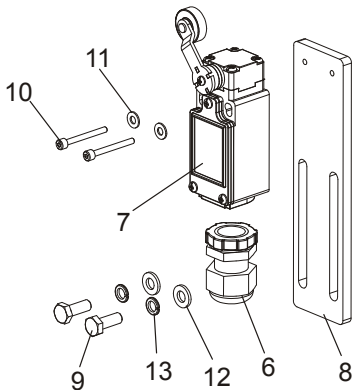

REF	DESCRIPTION (◆ Indicates Parts Available In Assemblies Only)	PART #	QTY.
1	SWITCH , GLCB01A2B SAFETY	086469	2
2	STUFFING-BOX, SKINTOP PG 13,5	086524	2
3	SUPPORT, POWER CORD BRACKET	090460-1 ¹	1
4	WASHER 4,3 FE/ZN5 PN-M/82005	F81051-2	4
5	SCREW, M4x35-8.8 HEX SOCKET HEAD CAP ZINC	F81011-34	4
	KIT, LT70 SAFETY SWITCH LOWER	505711	1
6	STUFFING-BOX, SKINTOP PG 13,5	086524	1
7	LIMIT SWITCH, GLCB01A1B	100931	1
8	BAR, SAFETY SWITCH MOUNT	505125-1	1
9	BOLT, M6 x 16 8.8 Fe/Zn5 PN-M/82105	F81001-15	2
10	BOLT, M3X30 8.8 SOCKET HEAD ZINC	F81011-38	2
11	WASHER 4,3 FE/ZN5 PN-M/82005	F81051-2	2
12	WASHER, M6, FLAT,ZINC	F81053-1	2

6 Up/Down System Safety Switches

13	WASHER, M6 SPLIT LOCK ZINC	F81053-3	2	
----	----------------------------	----------	---	--

¹ LT70DC version only.

SECTION 7 FEED SYSTEM & TRACK ROLLERS

7.1 Upper Track Rollers And Wipers

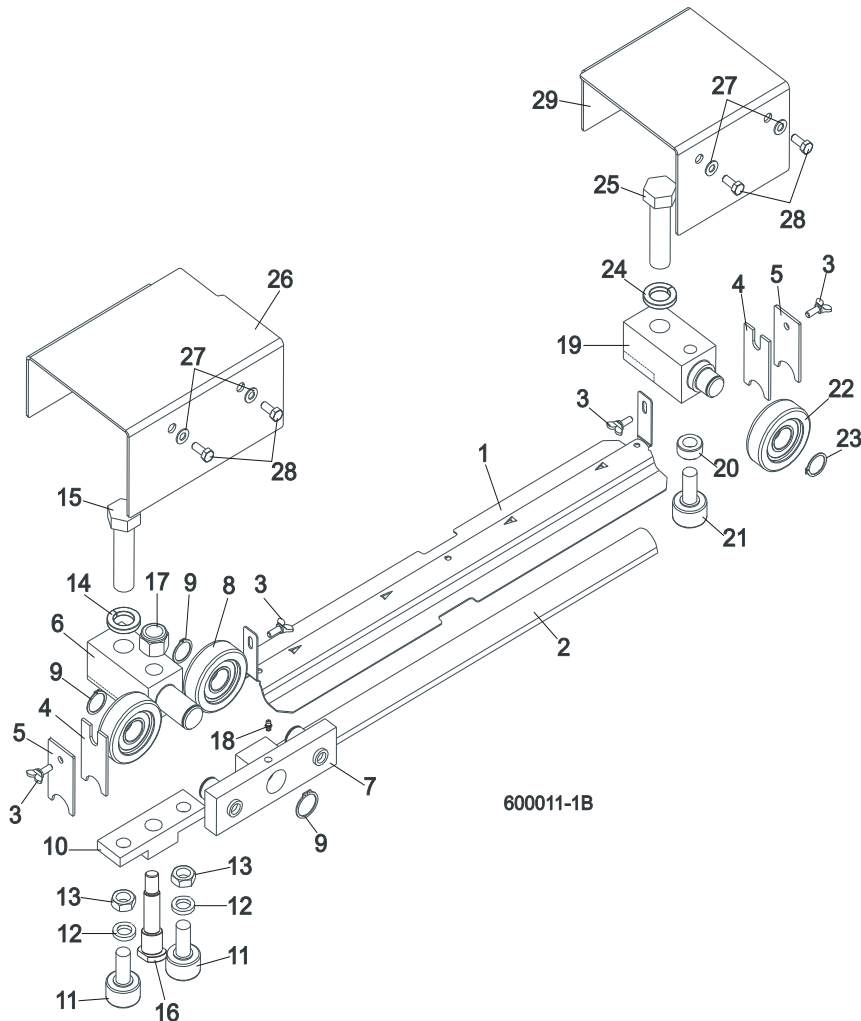

REF	DESCRIPTION (◆ Indicates Parts Available In Assemblies Only)	PART #	QTY.
1	COVER, LT40/70 MIDDLE TRACK - SERVICE	092868-S	1
	Cover, LT40/70 Middle Track Ptd	092868-1	1
2	Strip, 3/16 X 2 X 23 Felt	S09915	1
3	SCREW, M6X20 DIN 316 WING	F81001-58	4
4	WIPER, TOP RAIL	M04113	2
5	PLATE, TRACK WIPER	088559-1	2
	ROLLER ASSEMBLY, UPPER TANDEM TRACK	088530	1
6	Block, Tandem Roller Mount	088532	1
7	Block Assembly, Tandem Roller	088535	1
8	Bearing, CBK-468 Rolling	088433	2
9	Ring, Z30 Spring Retaining	F81090-23	2
10	Block, Cam Follower Mount	088520	1
11	Bearing, Cam Follower (McGill)	012797	2
12	Washer, 16.3 Split Zinc Lock	F81058-2	2
13	Nut, 5/8"-18 Zinc	F05010-11	2
14	Washer, Z24.5 Split Zinc Lock	F81061-4	1

15	Bolt, M24 x 2 x 90-8.8 Hex Head Full Thread Zinc	F81009-2	1	
16	Pin, Cam Follower Mount	088531	1	
17	Nut, M16-8 Hex Nylon Zinc Lock	F81036-2	1	
18	Fitting, M6 Straight Grease	086280	1	
	ROLLER ASSEMBLY, REAR UPPER TRACK	088529	1	
19	Block, Rear Upper Roller Mount	088528	1	
20	Spacer, Cam Follower	088536	1	
21	Bearing, Cam Follower (McGill)	012797	1	
22	Roller, CBK-468	088433	1	
23	Ring, Z30 Spring Retaining	F81090-23	1	
24	Washer, Z24.5 Split Zinc Lock	F81061-4	1	
25	Bolt, M24x2x90-8.8 Hex Head Full Thread Zinc	F81009-2	1	
26	COVER, TANDEM ROLLER	088526-1	1	
27	WASHER, 6.4 ZINC FLAT	F81053-1	4	
28	BOLT, M6X16 8.8 HEX HEAD FULL THREAD ZINC	F81001-15	4	
29	COVER, REAR UPPER ROLLER	088527-1	1	

7.2 Power Feed Assembly

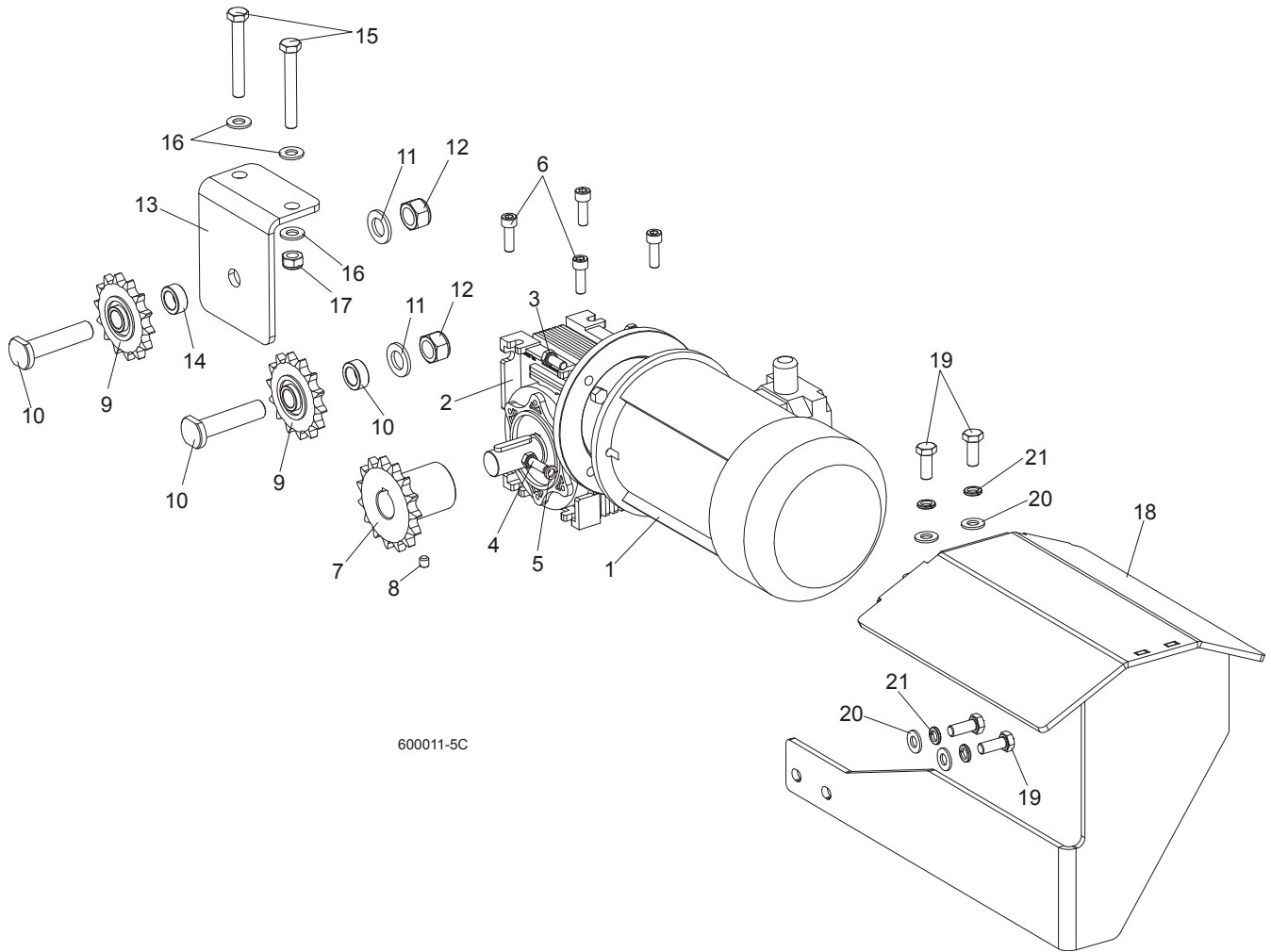

REF	DESCRIPTION (◆ Indicates Parts Available In Assemblies Only)	PART #	QTY.
	MOTOREDUCER MR-50/7.5/1.1-1380/K3/B8	100936	1
1	Electric motor 1,1kW AC	090104	1
2	MOTOREDUCER, MR-50/7.5/DO SILN/K3,N+S,B8	100935	1
3	BOLT, M8X20MM, HEX HEAD,GR 5.8 ZINC	F81002-4	2
4	BOLT,M8X25-8.8-B HEX HEAD FULL THREAD	F81002-5	2
5	WASHER 8,2 FE/ZN9	F81054-4	2
6	SCREW, M8x25 -8.8 HEX SOCKET HEAD CAP	F81002-21	4
7	SPROCKET, 10B Z15 ZINC	088541-1	1
8	SCREW, M8x8-33H HEX SOCKET SET FLAT POINT ZINC	F81014-1	2
9	SPROCKET, KSR 16.L0.10.10.14.08 W/BEARING	088867	2
10	PIN, ZINC SPROCKET MOUNT	088994-1	2
11	WASHER, 17 ZINC FLAT	F81058-1	2
12	NUT, M16-8 HEX NYLON ZINC LOCK	F81036-2	2
13	BRACKET, POWER FEED SPROCKET MOUNT	088507-1	1
14	SPACER, POWER FEED SPROCKET	088550-1	1
15	BOLT, M10x75-8.8 HEX HEAD ZINC	F81003-15	2

16	WASHER, 10.5 ZINC FLAT	F81055-1	4	
17	NUT, M10-8-B HEX NYLON ZINC LOCK	F81033-1	2	
	GUARD, LT70AC POWER FEED MOTOR COMPLETE	504651	1	
18	GUARD, LT70AC POWER FEED MOTOR	504652-1	1	
19	BOLT, M10-1.5X25MM HH GR8.8	F81003-11	4	
20	WASHER, 10.5 ZINC FLAT	F81055-1	4	
21	WASHER, 10.2 SPLIT LOCK ZINC	F81055-2	4	

7.3 Feed Chain/Stop, LT70 S/M

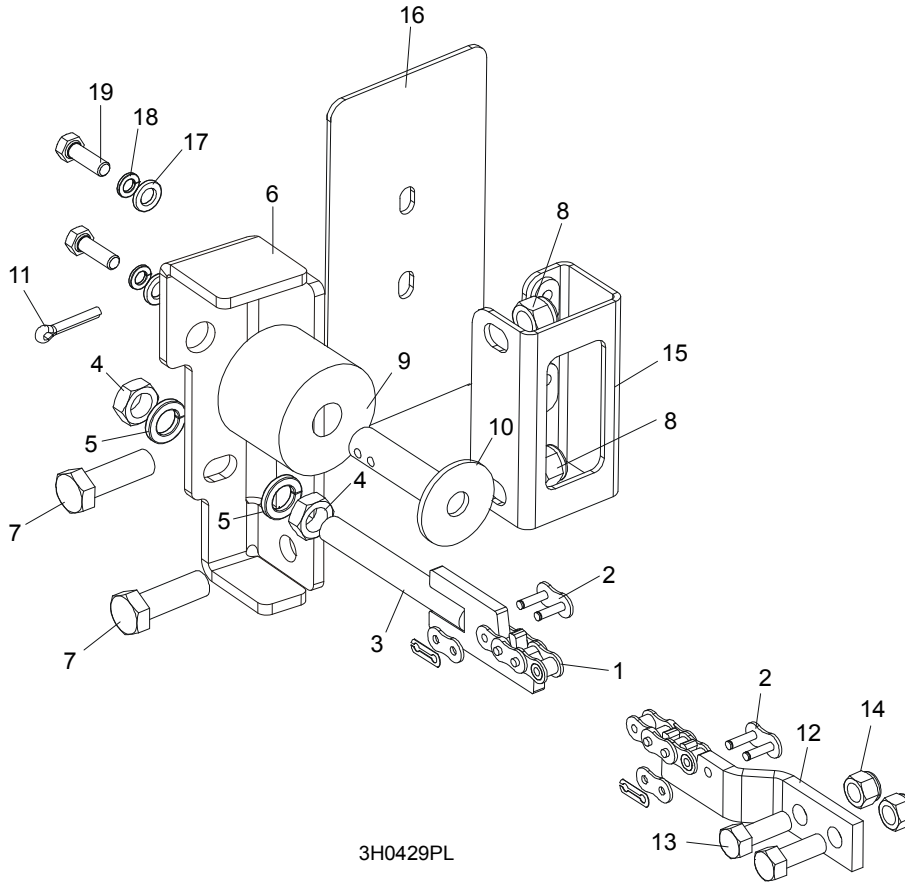

3H0429PL

REF	DESCRIPTION (◆ Indicates Parts Available In Assemblies Only)	PART #	QTY.
1	CHAIN, 10B-1-375 (5.95M) LT70S FEED	090427	1
	CHAIN, 10B-1-457 (7.25M) LT70M FEED	090370	1
2	LINK, 10B-1Pz MASTER	088671	2
3	TENSIONER WELDMENT, POWER FEED CHAIN ZINC-PLATED	086818-1	1
4	NUT, M12-5 HEX JAM	F81034-4	2
5	WASHER, 12.2 SPLIT LOCK	F81056-2	2
6	BRACKET, FEED CHAIN REAR MOUNT	087628-1	1
7	BOLT, M12 X 40 8.8 HEX HEAD GRADE 5	F81004-4	2
8	NUT, M12-8 HEX NYLON LOCK	F81034-2	2
	STOP KIT, RUBBER CARRIAGE	K09630	2
9	Stop, Rubber Carriage	P12165	1
10	Pin, Rubber Carriage Stop	W09293	1
11	Pin, 3/16" X 1" Cotter	F05012-21	1
12	BRACKET, FRONT FEED CHAIN MOUNT	015008	1
13	BOLT, 3/8-16 X 1" HEX HEAD	F05007-7	2
14	NUT, 3/8-16 HEX NYLON LOCK	F05010-10	2
15	BRACKET WELDMENT, REAR MAIN TUBE COVER MOUNT	087105-1	1
16	COVER, REAR MAIN TUBE	015023	1
17	WASHER, 8.4 FLAT	F81054-1	2
18	WASHER, 8.2 SPLIT LOCK	F81054-4	2
19	BOLT, 5/16-18 X 1" HEX HEAD	F05006-1	2

7.4 Lower Track Rollers

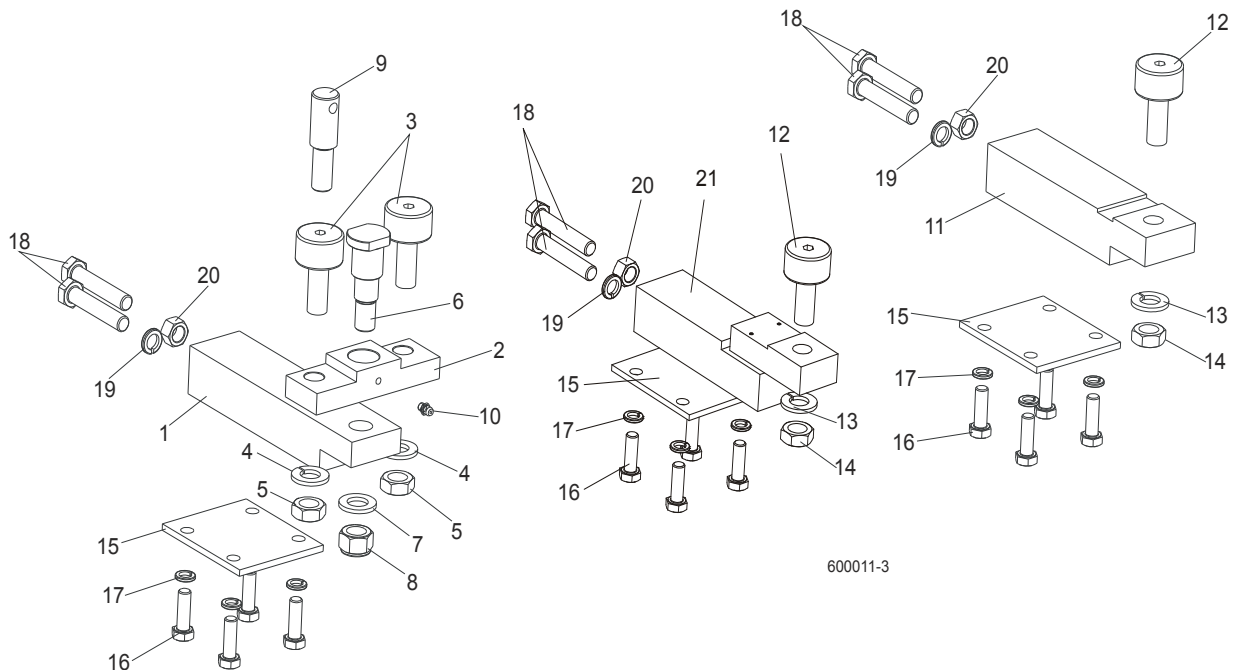

REF	DESCRIPTION (◆ Indicates Parts Available In Assemblies Only)	PART #	QTY.
	BLOCK ASSEMBLY, VERTICAL MAST ALIGNMENT DOUBLE	088523	1
1	Block, Vertical Mast Alignment Double	088517	1
2	Block, Cam Follower Mount	088520	1
3	Bearing, Cam Follower (McGill)	012797	2
4	Washer, 16.3 Split Zinc Lock	F81058-2	2
5	Nut, 5/8"-18 Zinc	F05010-11	2
6	Pin, Cam Follower Mount	088521	1
7	Washer, 17 Zinc Flat	F81058-1	1
8	Nut, M16-8 Hex Nylon Zinc Lock	F81036-2	1
9	Pin, Safety Lock	088519	1
10	Fitting, M6 Straight Grease	086280	1
	BLOCK ASSEMBLY, VERTICAL MAST ALIGNMENT SINGLE	088524	1
11	Block, Vertical Mast Alignment Single	088518	1
12	Bearing, Cam Follower (McGill)	012797	1
13	Washer, 16.3 Split Zinc Lock	F81058-2	1
14	Nut, 5/8"-18 Zinc	F05010-11	1
15	PLATE, LOWER TRACK ROLLER RETAINER	088516	3
16	BOLT, M10X30-5.8 HEX HEAD FULL THREAD ZINC	F81003-2	12
17	WASHER, 10.2 SPLIT ZINC LOCK	F81055-2	12
18	BOLT, M12X1.25X65-8.8 HEX HEAD FULL THREAD ZINC	F81004-40	6
19	WASHER, Z12.2 SPLIT ZINC LOCK	F81056-2	3
20	NUT, M12X1.25-8 ZINC HEX	F81034-8	3
21	BLOCK WELDMENT, LOWER TRACK ROLLER MOUNT	091425	1

SECTION 8 BED FRAME ASSEMBLY

8.1 Bed Rail Assembly, Front (LT40/70M Super)

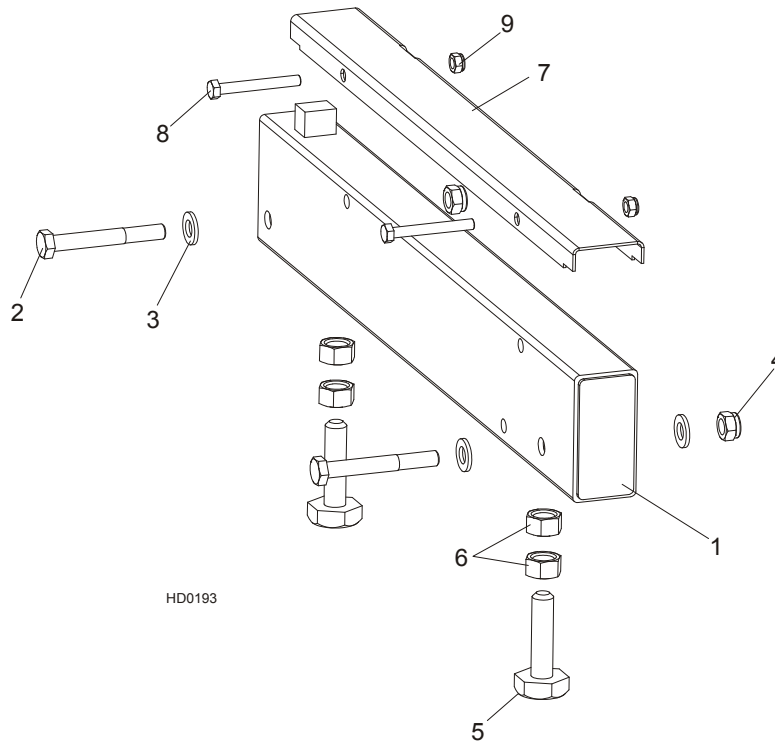

REF	DESCRIPTION (◆ Indicates Parts Available In Assemblies Only)	PART#	QTY.
1	BED RAIL ASSEMBLY, FRONT - LT70M SUPER	095646	1
2	Bolt, M12 x 90-8.8 Hex Head	F81004-2	2
3	Washer, 13 SAE Flat	F81056-1	4
4	Nut, M12-8 Hex Nylon Lock	F81034-2	2
5	Bolt, M16 Bed Rail Adjustment	505006	2
6	Nut, M16-5-B Hex Head Zinc	F81036-5	4
7	COVER, 22.75 SS LT50 PIVOT	S13012	1
8	BOLT, M8X65-5.8 ZINC HEX HEAD	F81002-3	2
9	NUT, M8-8-B HEX NYLON ZINC LOCK	F81032-2	2

8.2 Bed Rail Assembly, Middle (LT40/70M Super)

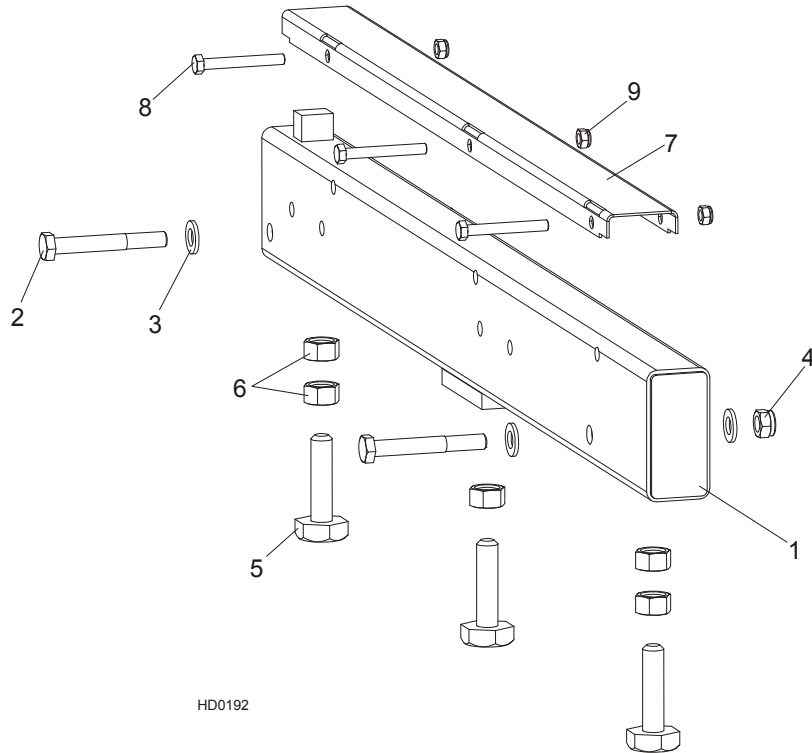

REF	DESCRIPTION (◆ Indicates Parts Available In Assemblies Only)	PART#	QTY.
1	BED RAIL ASSEMBLY, MIDDLE - LT70M SUPER	096478	1(4)
	BED RAIL ASSEMBLY, MIDDLE W/HOLE - LT70M SUPER	096993	1
	BED RAIL ASSEMBLY, MIDDLE (POWER ROLLER) - LT70M SUPER	095650	1
2	Bolt, M12 x 90-8.8 Hex Head	F81004-2	2
3	Washer, 13 SAE Flat	F81056-1	4
4	Nut, M12-8 Hex Nylon Lock	F81034-2	2
5	Bolt, M16 Bed Rail Adjustment	505006	3
6	Nut, M16-5-B Hex Head Zinc	F81036-5	5
7	COVER, STAINLESS STEEL BED RAIL	S09944	1
8	BOLT, M8X65-5.8 ZINC HEX HEAD	F81002-3	3
9	NUT, M8-8-B HEX NYLON ZINC LOCK	F81032-2	3

8.3 Board Removal Assembly, "Super" Series Stationary Sawmills w/"M" Frame

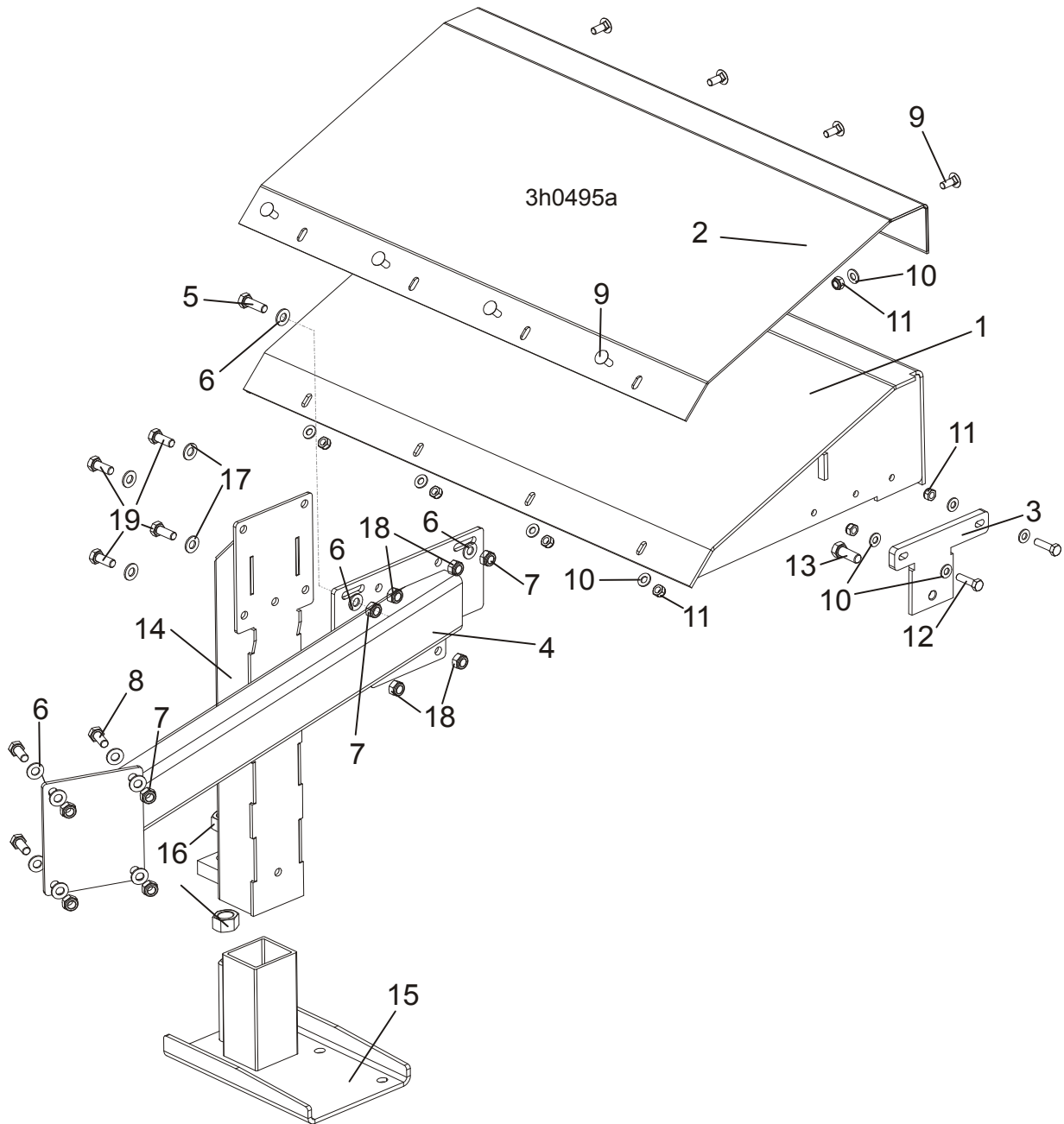

REF.	DESCRIPTION (◆ Indicates Parts Available In Assemblies Only)	PART#	QTY.
	BOARD REMOVAL ASSEMBLY, LT40" "M" AH/DH2-7 SUPER	100662	1
	BOARD REMOVAL ASSEMBLY, LT70" "M" AH/DH2-7 SUPER	100663	1
	BOARD REMOVAL ASSEMBLY See Section 4.3	087839-1	1
	BOARD REMOVAL ASSEMBLY See Section 4.3 (FOR LT70 SAWMILLS)	092757	1
	TABLE, "M" FRAME SUPER COMPLETE	100674	1
1	Table, "M" Frame	100672-1	1
2	Plate, Table Top	099946	1
3	Plate, "M" Frame Super Leg Mount	100675-1	1
4	Tube Weldment, "M" Frame Super Table Support	100670-1	1

BED FRAME ASSEMBLY*Board Removal Assembly, "Super" Series Stationary Sawmills w/"M" Frame*

5	Bolt, M10x30-5.8 Hex Head Full Thread Zinc	F81003-2	2	
6	Washer, 10.5 Flat Zinc	F81055-1	12	
7	Nut, M10-8-B Hex Nylon Zinc Lock	F81033-1	6	
8	Bolt, M10x25-8.8 Hex Head Full Thread Zinc	F81003-11	4	
9	Bolt, M8x20-8.8 Carriage Head Zinc	F81002-11	8	
10	Washer, 8.4 Flat Zinc	F81054-1	13	
11	Nut, M8-8-B Hex Nylon Zinc Lock	F81032-2	10	
12	Bolt, M8x30-5.8 Hex Head Full Thread Zinc	F81002-2	2	
13	Bolt, M12x30-8.8 Hex Head Full Thread Zinc	F81004-22	1	
	LEG, LEFT STATIONARY ADJUSTABLE	501639	1	
14	Leg Weldment - Upper Part	500545-1	1	
15	Wide Foot - Adjustable Legs	501084-1	1	
16	Nut, M20-8 Hex Zinc	F81037-1	2	
17	Washer, 10.5 Flat Zinc	F81055-1	4	
18	Nut, M10-8-B Hex Nylon Zinc Lock	F81033-1	4	
19	Bolt, M10x25-8.8 Hex Head Full Thread Zinc	F81003-11	4	

8.4 Board Removal Assembly, Portable "Super" Series Sawmills w/"M" Frame

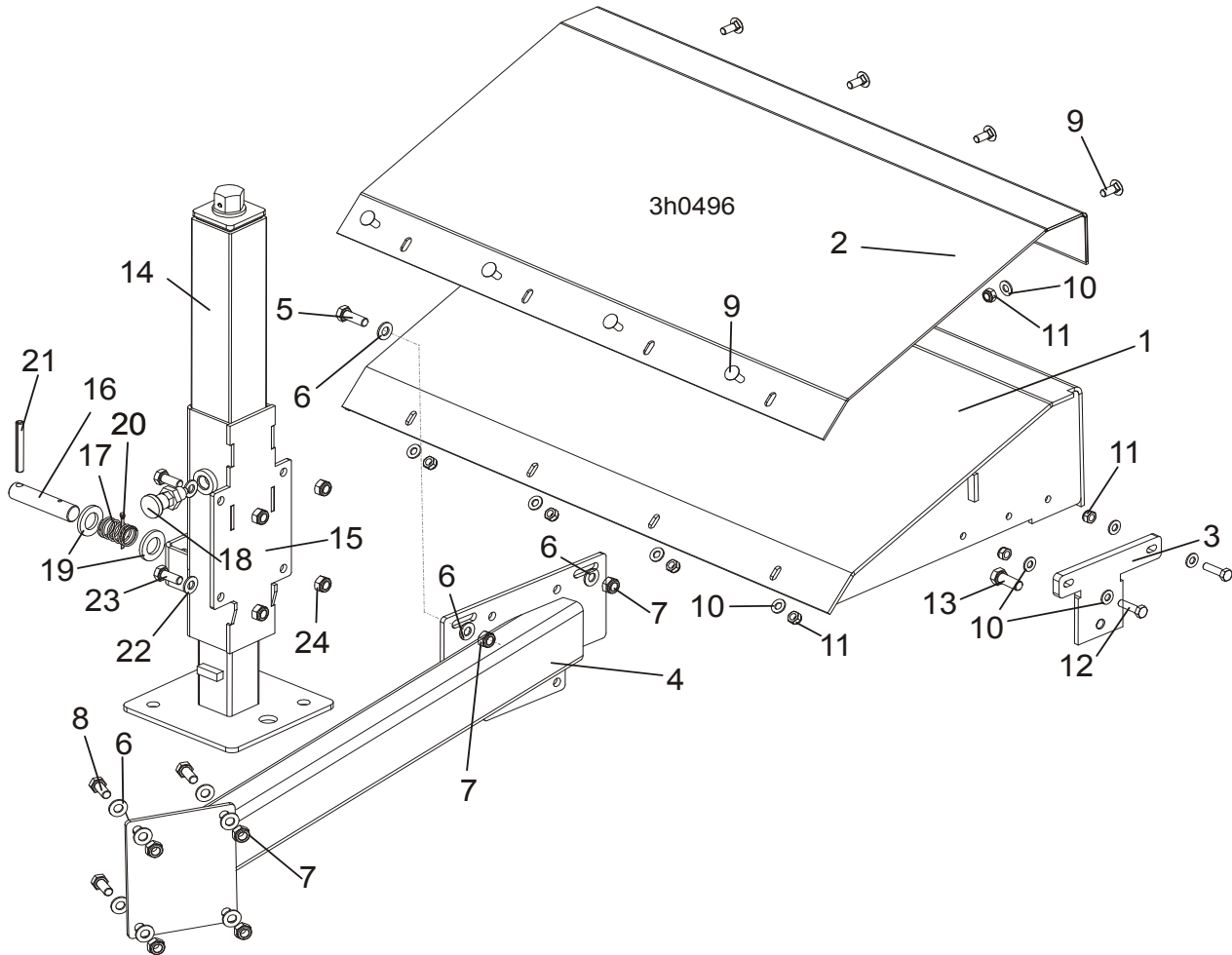

REF.	DESCRIPTION (◆ Indicates Parts Available In Assemblies Only)	PART#	QTY.
	BOARD REMOVAL ASSEMBLY, LT40MAH/DHS2-7SUPER PORTABLE	506532	1
	BOARD REMOVAL ASSEMBLY, LT70MAH/DHS2-7SUPER PORTABLE	506533	1
	BOARD REMOVAL ASSEMBLY See Section 4.3	087839-1	1
	BOARD REMOVAL ASSEMBLY See Section 4.3 (FOR LT70 SAWMILLS)	092757	1
	TABLE ASSEMBLY, "M" FRAME SUPER PORTABLE	506534	1
1	Table, "M" Frame	100672-1	1
2	Plate, Table Top	099946	1
3	Plate, "M" Frame SUPER Leg Mount	100675-1	1
4	Tube Weldment, "M" Frame Super Table Support	100670-1	1
5	Bolt, M10x30-5.8 Hex Head Full Thread Zinc	F81003-2	2
6	Washer, 10.5 Flat Zinc	F81055-1	12
7	Nut, M10-8-B Hex Nylon Zinc Lock	F81033-1	6
8	Bolt, M10x25-8.8 Hex Head Full Thread Zinc	F81003-11	4
9	Bolt, M8x20-8.8 Carriage Head Zinc	F81002-11	8
10	Washer, 8.4 Flat Zinc	F81054-1	13
11	Nut, M8-8-B Hex Nylon Zinc Lock	F81032-2	10
12	Bolt, M8x30-5.8 Hex Head Full Thread Zinc	F81002-2	2
13	Bolt, M12x30-8.8 Hex Head Full Thread Zinc	F81004-22	1

BED FRAME ASSEMBLY*Board Removal Assembly, Portable "Super" Series Sawmills w/"M" Frame*

	LEG, COMPLETE SIDE FAO	094583	1	
14	BASE WELDMENT, FINE ADJUST OUTRIGGER LEG	093589	1	
15	GUIDE WELDMENT, SIDE FAO LEG	504243-1	1	
16	PIN, OUTRIGGER ZINC-PLATED	087012-1	1	
17	SPRING, 21 DIA.x38x2 ZINC-PLATED	087040	1	
18	PIN, DETENT	090197	1	
19	WASHER, 21 FLAT ZINC	F81059-2	2	
20	PIN, S-Zn 4x25 COTTER	F81043-2	1	
21	PIN, 8x65 ROLL ZINC	F81046-1	1	
22	WASHER, 10.5 FLAT ZINC	F81055-1	4	
23	BOLT, M10x25-8.8 HEX HEAD FULL THREAD ZINC	F81003-11	4	
24	NUT, M10-8-B HEX NYLON ZINC LOCK	F81033-1	4	

8.5 Board Return Assembly - (LT40M Super Option)

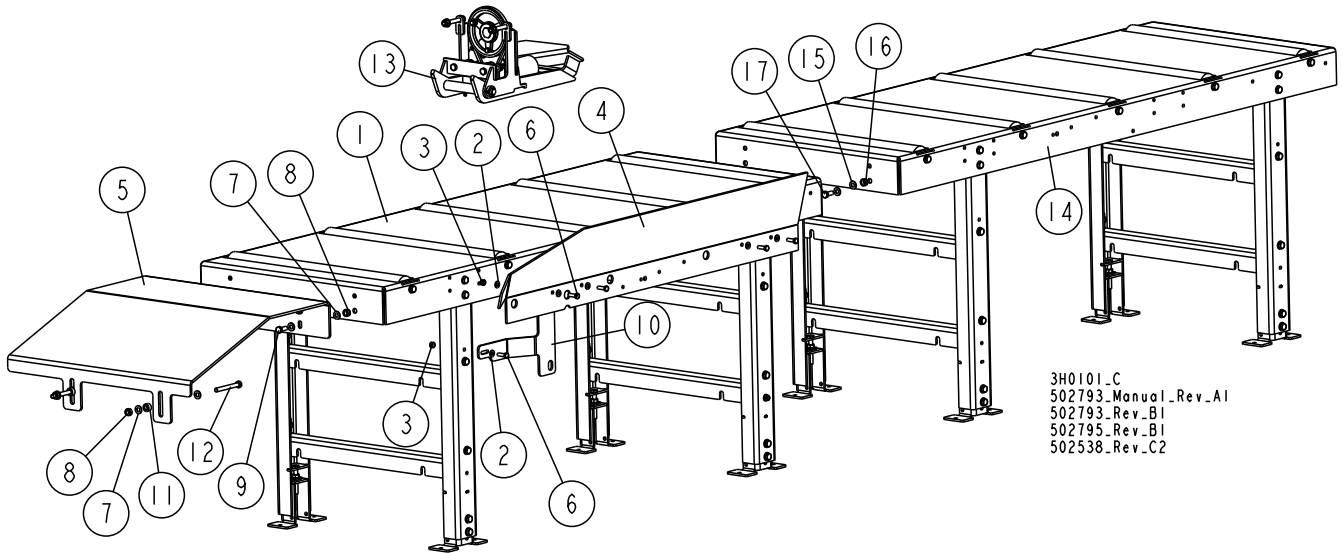

REF	DESCRIPTION (◆ Indicates Parts Available In Assemblies Only)	PART #	QTY.
	TABLE, LT40M SUPER DOUBLE	502793	1
	TABLE, LT40M SUPER LONG	502795	1
	TABLE, M FRAME MODULE REAR	502538	1
1	TABLE, M FRAME MODULE REAR See Section 8.7	502539	1
2	WASHER, 8.4 FLAT ZINC	F81054-1	13
3	NUT, M8-8-B HEX NYLON ZINC LOCK	F81032-2	8
4	BRACKET, BOARD RETURN TABLE	501978-1	1
5	PLATE, FRONT, BOARD RETURN TABLE	502811-1	1
6	BOLT, M8X25-8.8-B HEX HEAD FULL THREAD	F81002-5	5
7	WASHER, 10.5 FLAT ZINC	F81055-1	12
8	NUT, M10-8-B NYLON HEX ZINC LOCK	F81033-1	6
9	BOLT, M10x25-8.8-Fe/Zn5 PN-M/82101	F81003-11	4
10	CONNECTOR M-SUPER FRAME- TABLE	511685-1	1
11	BUSHING, ZINC-PLATED SPACER	090936-1	2
12	BOLT, M10X90-8.8-B HEX HEAD ZINC	F81003-66	2
13	BOARD RETURN ASSEMBLY See Section 4.3	087839-1	1
14	WASHER, 10.5 FLAT ZINC	F81055-1	4
15	NUT, M10-8-B NYLON HEX ZINC LOCK	F81033-1	2
16	BOLT, M10x25-8.8-Fe/Zn5 PN-M/82101	F81003-11	2

8 BED FRAME ASSEMBLY

Board Return Assembly - (LT70M Super Option)

8.6 Board Return Assembly - (LT70M Super Option)

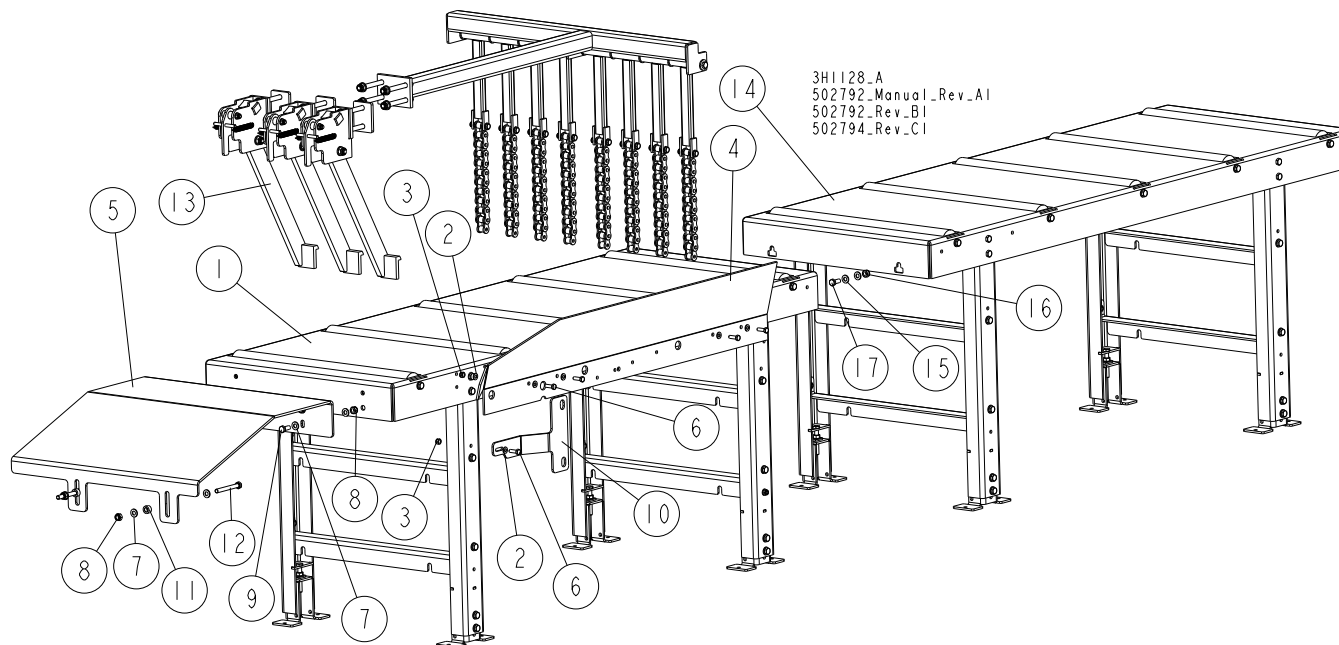

REF	DESCRIPTION (◆ Indicates Parts Available In Assemblies Only)	PART #	QTY.
	TABLE, LT70M SUPER DOUBLE	502792	1
	TABLE, LT40M SUPER LONG	502794	1
	TABLE, M FRAME MODULE REAR	502538	1
1	TABLE, M FRAME MODULE REAR See Section 8.7	502539	1
2	WASHER, 8.4 FLAT ZINC	F81054-1	13
3	NUT, M8-8-B HEX NYLON ZINC LOCK	F81032-2	8
4	BRACKET, BOARD RETURN TABLE	501978-1	1
5	PLATE, FRONT, BOARD RETURN TABLE	502811-1	1
6	BOLT, M8X25-8.8-B HEX HEAD FULL THREAD	F81002-5	5
7	WASHER, 10.5 FLAT ZINC	F81055-1	12
8	NUT, M10-8-B NYLON HEX ZINC LOCK	F81033-1	6
9	BOLT, M10x25-8.8-Fe/Zn5 PN-M/82101	F81003-11	4
10	CONNECTOR M-SUPER FRAME- TABLE	511685-1	1
11	BUSHING, ZINC-PLATED SPACER	090936-1	2
12	BOLT, M10X90-8.8-B HEX HEAD ZINC	F81003-66	2
13	BOARD RETURN ASSEMBLY See Section 4.5	092757	1
14	TABLE, M FRAME MODULE REAR	502539	1
15	WASHER, 10.5 FLAT ZINC	F81055-1	4
16	NUT, M10-8-B NYLON HEX ZINC LOCK	F81033-1	2
17	BOLT, M10x25-8.8-Fe/Zn5 PN-M/82101	F81003-11	2

8.7 Long Table

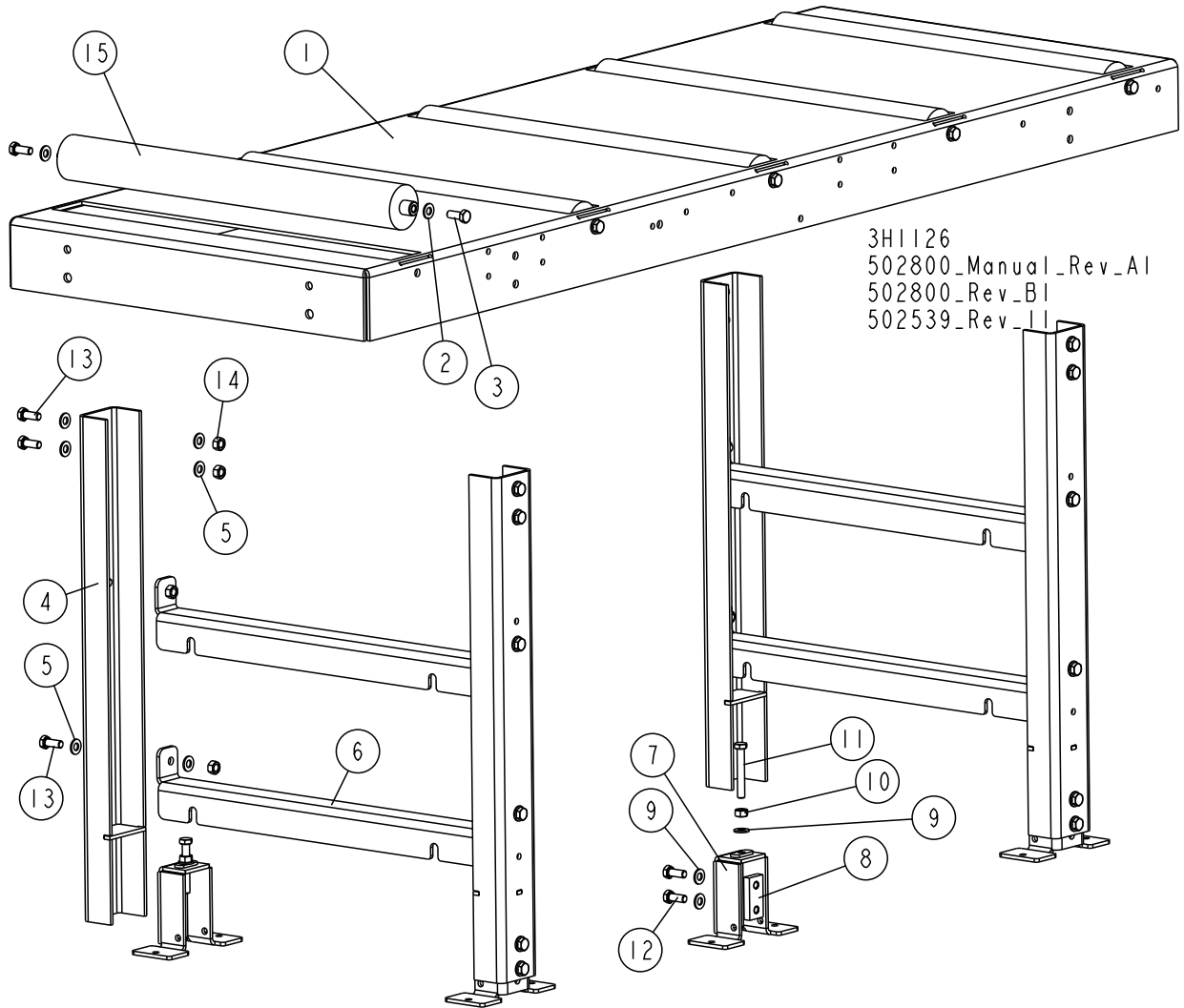

L.P.	OPIS (♦ wskazuje części dostępne jedynie w zespołach)	NUMER KAT.	SZT.
	LONG TABLE, "M" FRAME	502539	1
1	TABLE WLDMT, BOARD RETURN	512488-1	1
2	Washer, 10.5 Flat	F81055-1	10
3	BOLT, M10-1.5X25MM HH GR8.8	F81003-11	10
	LEG, TABLE COMPLETE	501974	2
4	LEG, TABLE	501976	2
5	Washer, 10.5 Flat	F81055-1	15
6	CROSS-BAR, TABLE	500074-1	2
	COMPLETE, ADJUSTABLE LEG FOOT	101014	2
7	FOOT, LEG ADJUSTABLE	101022-1	1
8	PLATE, M10 CLAMPING ZINC-PLATED	101242-1	1
9	Washer, 10.5 Flat	F81055-1	3
10	NUT, M10-8-B-HEX ZINC	F81033-3	1
11	BOLT, M10x70-8.8-HEX HEAD FULL THREAD ZINC	F81003-20	1
12	BOLT, M10x25-8.8-HEX HEAD FULL THREAD ZINC	F81003-11	2

L.P.	OPIS (◆ wskazuje części dostępne jedynie w zespołach)	NUMER KAT.	SZT.	
13	BOLT, M10x25-8.8-HEX HEAD FULL THREAD ZINC	F81003-11	8	
14	NUT, M10-8-B-HEX ZINC	F81033-3	8	
15	ROLLER 63.5/20X590	501090-1	5	

8.8 Stationary Leg Kit, M Super Frame

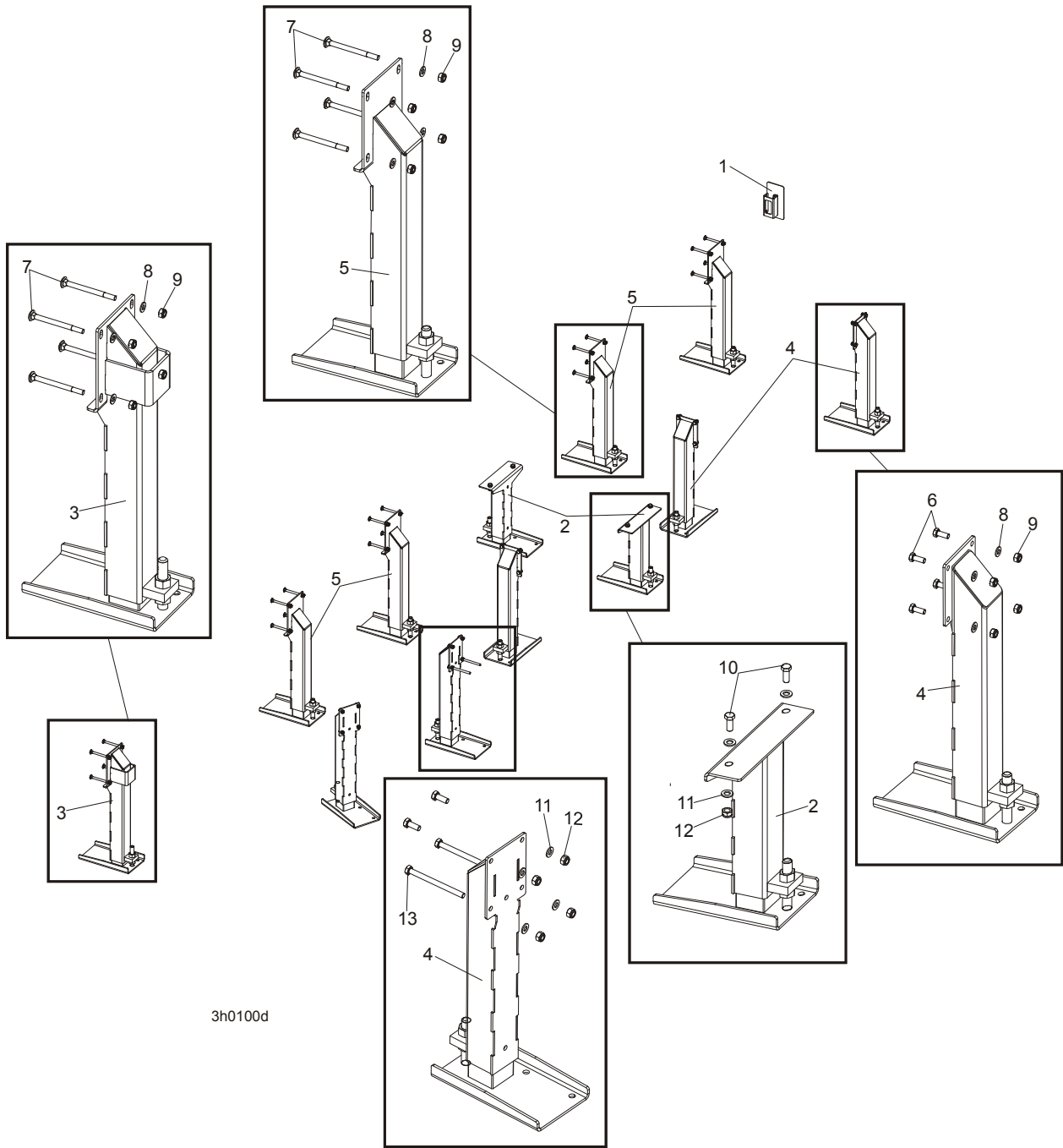

3h0100d

REF	DESCRIPTION (◆ Indicates Parts Available In Assemblies Only)	PART #	QTY.
	STATIONARY LEG KIT, M SUPER FRAME	097299	1
1	COVER ASSEMBLY, MAIN TUBE	093052	1
2	LEG, OUTRIGGER STATIONARY MIDDLE	501637	2
3	LEG, OUTRIGGER STATIONARY W/BOARD RETURN TABLE BRACKET	501638	1
4	LEG, OUTRIGGER STATIONARY LEFT	501639	5
5	LEG, OUTRIGGER STATIONARY RIGHT	501640	4
6	Bolt, M10-1.5x25mm HH Gr8.8	F81003-11	20

8 BED FRAME ASSEMBLY

Outrigger Leg Kit, M Super Frame

7	BOLT, M10X120 8.8 FE/ZN5	F81003-33	20	
8	WASHER, 10.5 FLAT ZINC	F81055-1	40	
9	NUT, M10-8-B HEX NYLON ZINC LOCK	F81033-1	40	
10	BOLT, M12X30-8.8 HEX HEAD FULL THREAD ZINC	F81004-22	4	
11	WASHER, 13 FLAT ZINC	F81056-1	8	
12	NUT, M12-8 HEX NYLON ZINC LOCK	F81034-2	4	
13	BOLT, M10x125-8.8 HEX HEAD ZINC	F81003-18	2	

8.9 Outrigger Leg Kit, M Super Frame

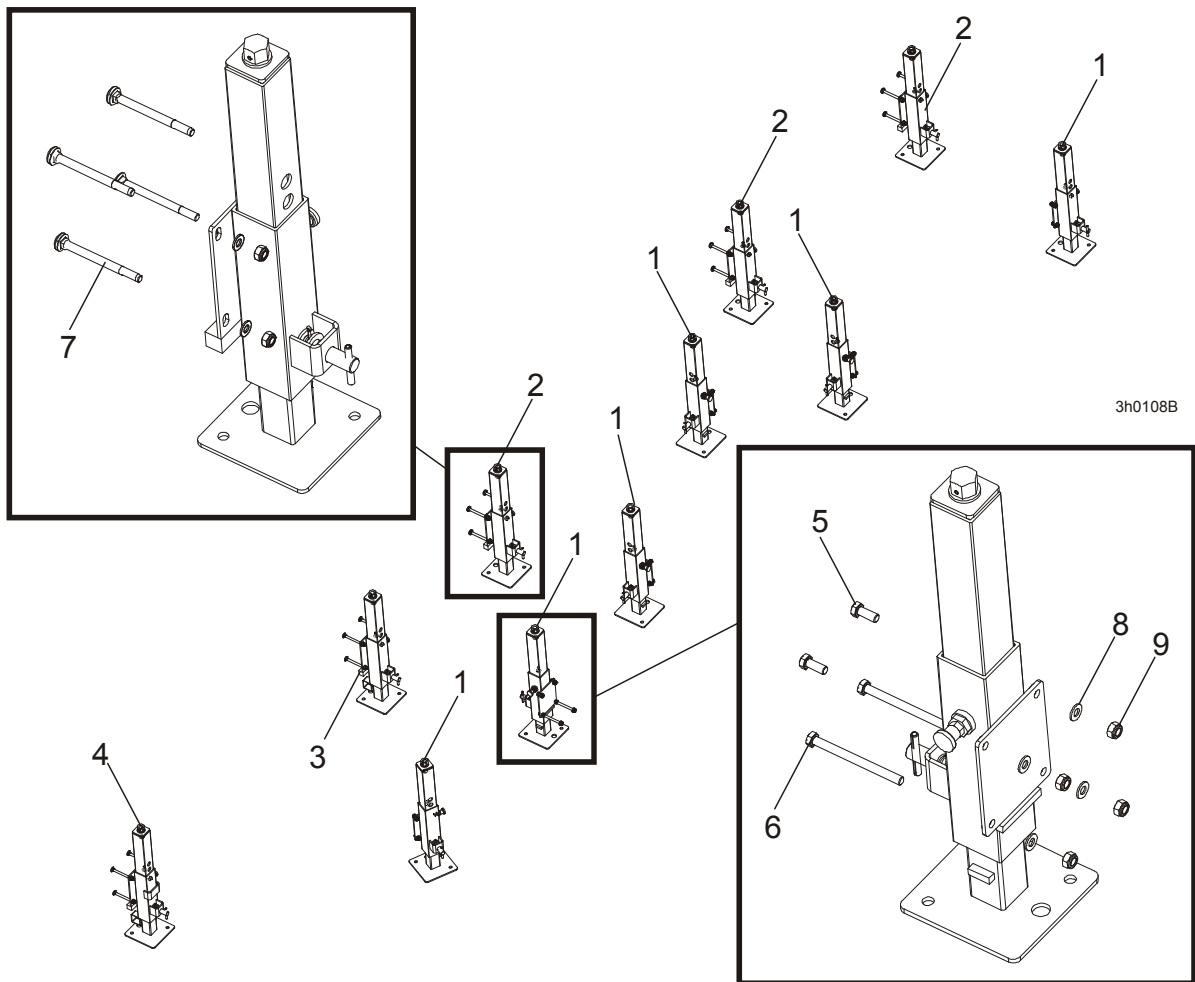

REF	DESCRIPTION (◆ Indicates Parts Available In Assemblies Only)	PART#	QTY.	
	OUTRIGGER LEG KIT, M SUPER FRAME	095707	1	
1	FINE ADJUST OUTRIGGER ASSEMBLY, SIDE	094583	6	
2	FINE ADJUST OUTRIGGER ASSEMBLY, MIDDLE AND REAR	094584	3	
3	FINE ADJUST OUTRIGGER ASSEMBLY, S & M FRAME	094586	1	
4	FINE ADJUST OUTRIGGER ASSEMBLY, FRONT	094587	1	
5	BOLT, M10-1.5X25MM HH GR8.8	F81003-11	18	
6	BOLT, M10x125-8.8 HEX HEAD ZINC	F81003-18	2	
7	BOLT, M10X120 8.8 FE/ZN5	F81003-33	16	
8	WASHER, 10.5 FLAT ZINC	F81055-1	36	

9	NUT, M10-8-B HEX NYLON ZINC LOCK	F81033-1	36
---	----------------------------------	----------	----

8.10 LT40/70M Saw Head Rest Pin Assembly

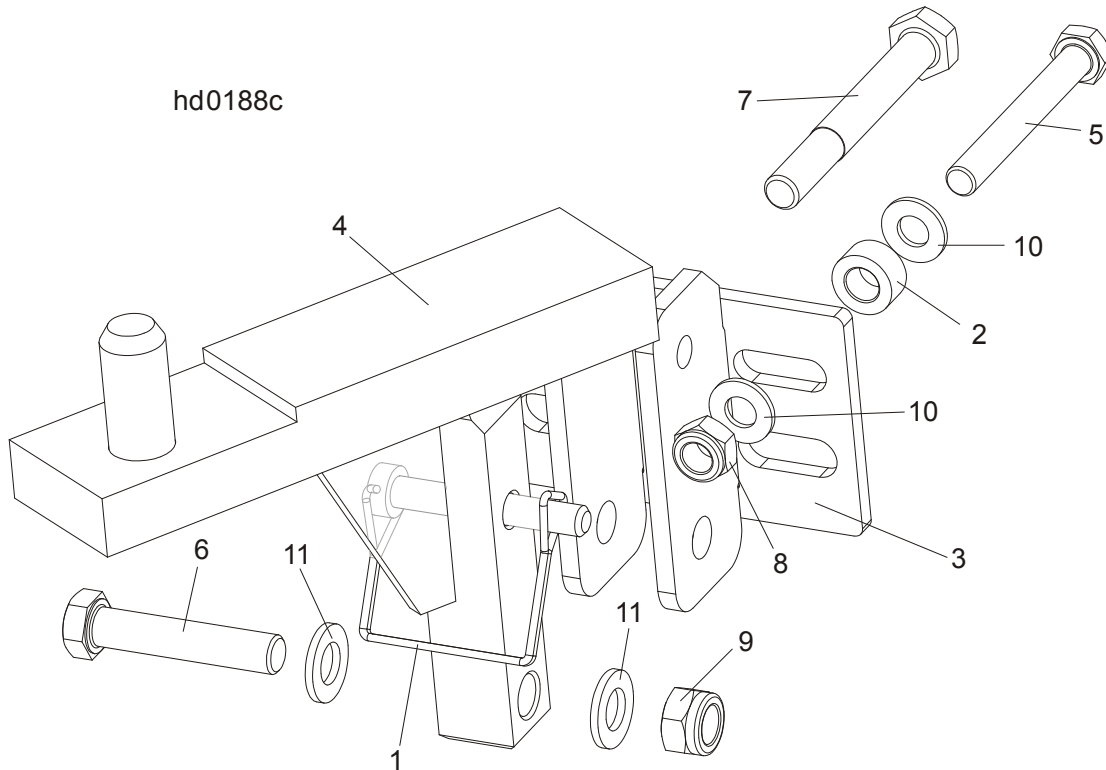

REF	DESCRIPTION (◆ Indicates Parts Available In Assemblies Only)	PART#	QTY.
	SAW HEAD REST PIN W/LATCH CLAMP, LT70S/M	094660	1
1	PIN, 3/8 x 2 1/4 SQ WIRE LOCK	014151	1
2	BUSHING, ZINC-PLATED SPACER	090936-1	1
3	BRACKET, LT40 SAW HEAD REST PIN MOUNT	092765-1	1
4	PIN WLDMT, LT70S/M SAW HEAD REST	094658-1	1
5	BOLT, M10 X 80 -8.8- FE/ZN5 HEX HEAD	F81003-50	1
6	BOLT, M12X60MM, HEX HEAD GR 8.8	F81004-5	1
7	BOLT, M12x95 -8.8- HEX HEAD ZINC-PLATED	F81004-29	1
8	NUT, M10-8-B HEX NYLON ZINC LOCK	F81033-1	1
9	NUT, M12-8 HEX NYLON ZINC LOCK	F81034-2	1
10	WASHER, 10.5 FLAT ZINC	F81055-1	2
11	WASHER, 13 FLAT ZINC	F81056-1	2

8.11 Tie Down Chain Assembly

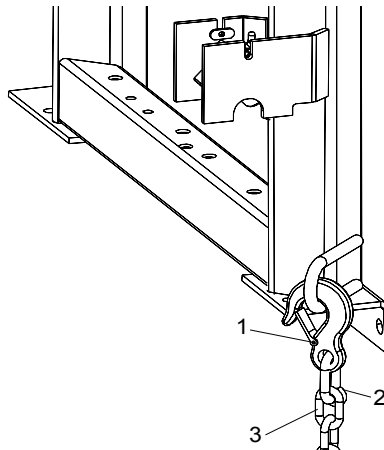

REF	DESCRIPTION (◆ Indicates Parts Available In Assemblies Only)	PART #	QTY.
	CHAIN ASSEMBLY, TIE DOWN	A04376-1	1
1	Hook, 5/8" Safety Chain	P12075	1
2	Screw Closed Chain Link, 10	100767	1
3	Chain, N-10 x 35, 6 Links	100951	1

8.12 Blockade Control Box LT40

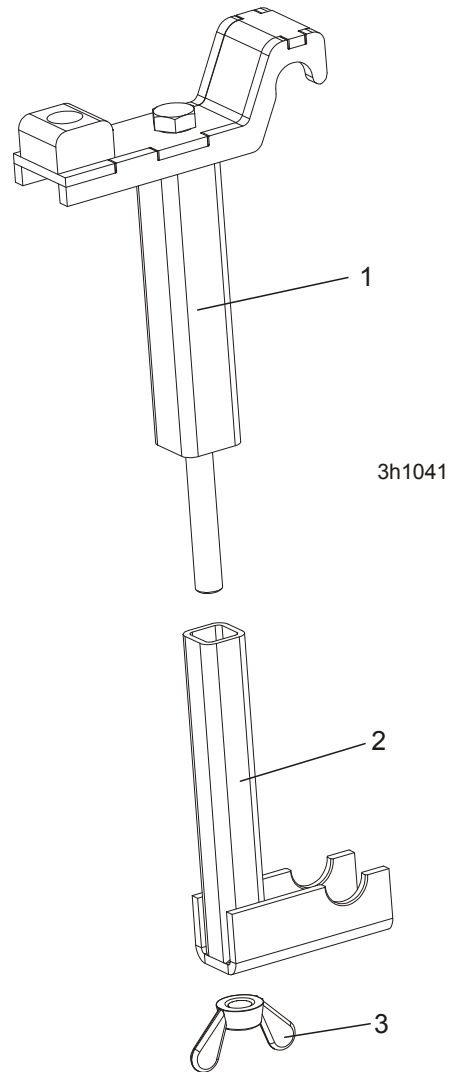

REF	DESCRIPTION (◆ Indicates Parts Available In Assemblies Only)	PART #	QTY.
	BLOCKADE CONTROL BOX LT40/70 (M SUPER FRAME)	506987	1
1	UPPER CONTROL BOX BLOCKADE	506983-1	1
2	LOWER CONTROL BOX BLOCKADE	506985-1	1
3	NUT, M16 WING	F81036-3	1

8.13 Remote Equipment Option

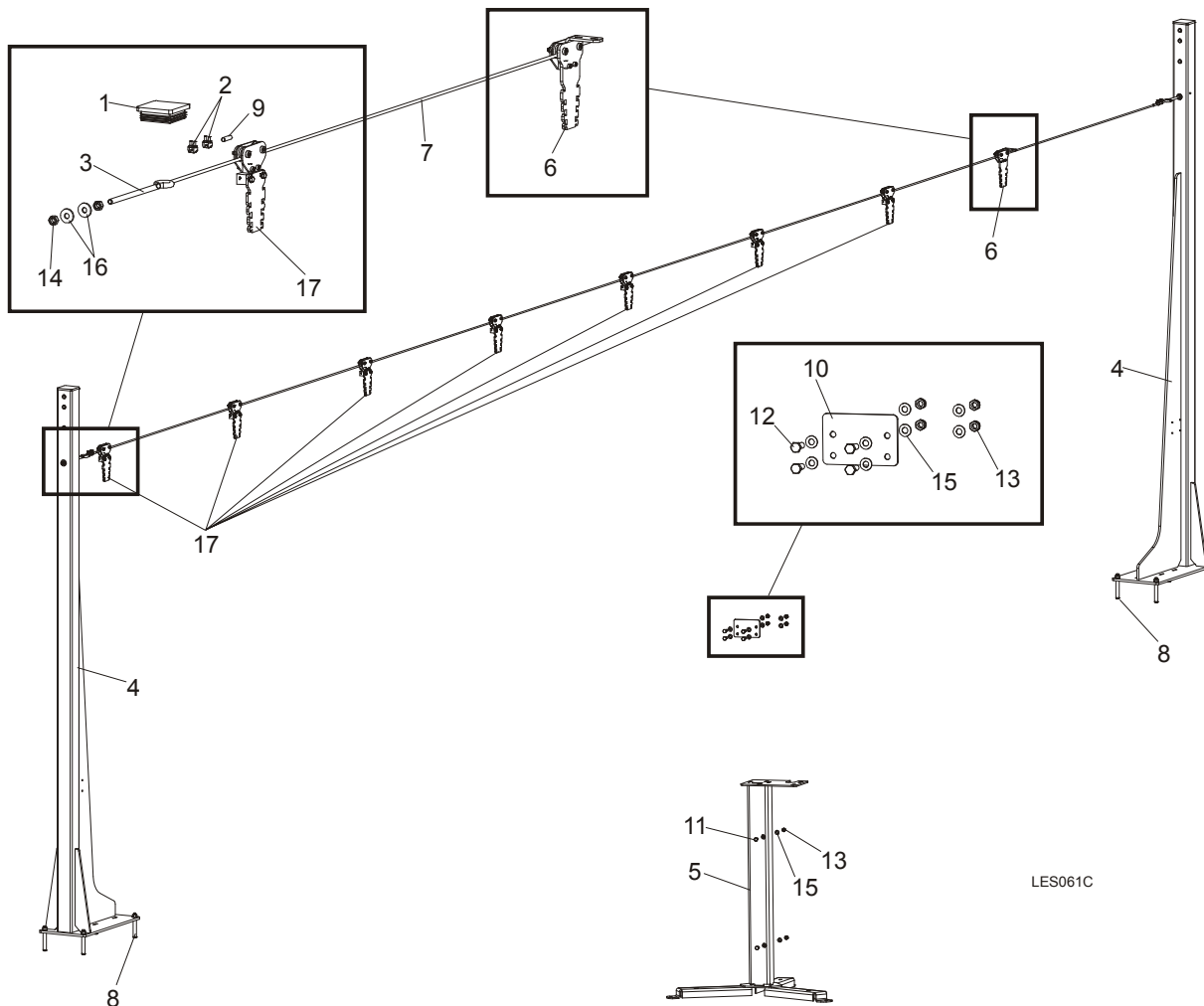

REF.	DESCRIPTION (◆ Indicates Parts Available In Assemblies Only)	PART #	QTY.
	EQUIPMENT, LT20B REMOTE COMPLETE	501649	1
1	CAP, EDGER FRAME	089644	2
2	CLAMP, LT20 STRING	091614	4
3	TENSIONER, ZINC-PLATED	500846-1	2
4	COLUMN, LT20B LINE GUIDE	503600-1	2
5	STAND, LT20B CONTROL BOX	501651-1	1
6	PULLEY, STATIONARY	504264	1
7	CABLE, 6MM (11,5 M) STEEL	504279	1
8	PIN, LT 16X120	501877	8
9	POINTER, 6MM STEEL CABLE	504280-1	2
10	CAP, LT20B REMOTE CONTROL BOX	501879-1	1
11	BOLT, M8X20-5.8 HEX HEAD FULL THREAD ZINC	F81002-1	2
12	BOLT, M8x25-8.8-B HEX HEAD FULL THREAD ZINC	F81002-5	4
13	NUT, M8-8-B HEX NYLON ZINC LOCK	F81032-2	6
14	NUT, M10-8-B-FE	F81033-3	4

15	WASHER, 8.4 FLAT ZINC	F81054-1	12	
16	WASHER,10.5 ZINC FLAT SPECIAL	F81055-6	4	
17	PULLEY	504114	7	

SECTION 9 HYDRAULIC SYSTEM

9.1 Hydraulic Hoses, LT40/70M Super

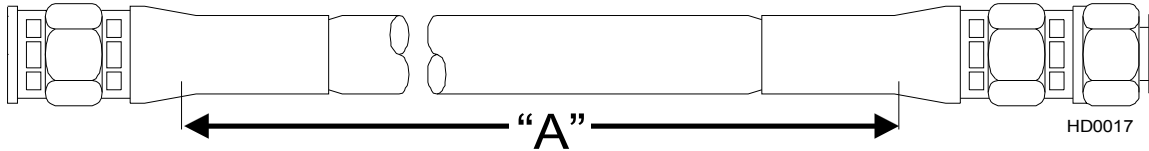

Part	Color Code	LENGTH "A" [m]	Application	Wood-Mizer Part No.
			I Section (from filter) according to designations from right to left	
A1	White	3.5	3/8" 2-Plane Clamp, In/Out	097614
B1	Orange	3.5	3/8" 2-Plane Clamp, In/Out	097615
A2	Pink	3.6	3/8" Raising the turner and side supports	097622
B2	Plain	3.6	3/8" Raising the turner and side supports	097622
A3	Red	5.6	1/4" III Clamp (middle), Up/Down	097545
B3	Blue	5.6	1/4" III Clamp (middle), Up/Down	097545
A4	Silver	4.9	1/4" I Toe Board	097620
B4	Brown	4.9	1/4" I Toe Board	097620
A5	Black	3.3	3/8" Chain Turner Hydraulic Motor	097619
B5	Brown	3.3	3/8" Chain Turner Hydraulic Motor	097619
A6	Orange	5.0	1/4" III Clamp (middle), In/Out	097545
B6	White	5.0	1/4" III Clamp (middle), In/Out	097545
A7	Red	1.8	3/8" Log Loader	097623
B7	Blue	1.8	3/8" Log Loader	097623
			II Section according to designations from right to left	
A1	Purple	4.8	1/4" I Toe Board Drive	097621
B1	Purple	4.8	1/4" I Toe Board Drive	097621
A2	Black	2.0	1/4" II Toe Board	097617
B2	Purple	2.0	1/4" II Toe Board	097617
A3	Red	6.2	1/4" I Clamp, Up/Down	097616
B3	Blue	6.2	1/4" I Clamp, Up/Down	097616
A4	Orange	5.5	1/4" I Clamp, In/Out	097616
B4	White	5.5	1/4" I Clamp, In/Out	097616
A5	Yellow	4.4	1/4" 2-Plane Clamp, Up/Down	097613
B5	Green	4.4	1/4" 2-Plane Clamp, Up/Down	097613
A6	Red	1.0	1/4" II Clamp, Up/Down	097618
B6	Blue	1.0	1/4" II Clamp, Up/Down	097618
A7	Orange	2.0	1/4" II Clamp, In/Out	097617

TABLE 0-0

B7	White	2.0	1/4" II Clamp, In/Out	097617
	Green	2.1	3/8" tee connector to log loader cylinder	097624
	Yellow	2.2	3/8" tee connector to log loader cylinder	097624
	Green	0.8	3/8" tee connector to log loader cylinder	097625
	Yellow	0.95	3/8" tee connector to log loader cylinder	097625
		0.65	3/8" turner hose	094597
		0.65	3/8" turner hose	094597
		0.75	3/8" left side support hose	094596
		1.0	3/8" right side support hose	094593
		1.0	3/8" right side support hose	094593
		1.2	3/8" cylinder instrumentation	097625

TABLE 0-0

Protective Conduits, LT40/70M Super Hydraulic Hoses

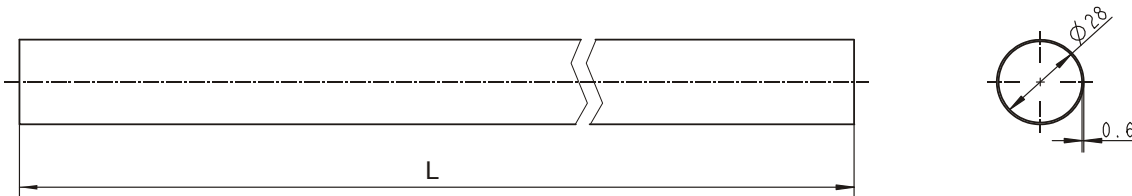

LENGTH "L"	DESCRIPTION (◆ Indicates Parts Available In Assemblies Only)	PART #	QTY.	
0,85	PROTECTIVE CONDUIT, HYDRAULIC MOTOR HOSE	100127	2	
1,00	PROTECTIVE CONDUIT, SIDE SUPPORT HOSE	100128	4	
0,70	PROTECTIVE CONDUIT, LOG TURNER HOSE	099761	3	
0,45	PROTECTIVE CONDUIT, IN/OUT CYLINDER HOSE - TOP	099763	1	



HYDRAULIC SYSTEM

Hydraulic Control Box, LT40/70M Super (AC)

9.2 Hydraulic Control Box, LT40/70M Super (AC)

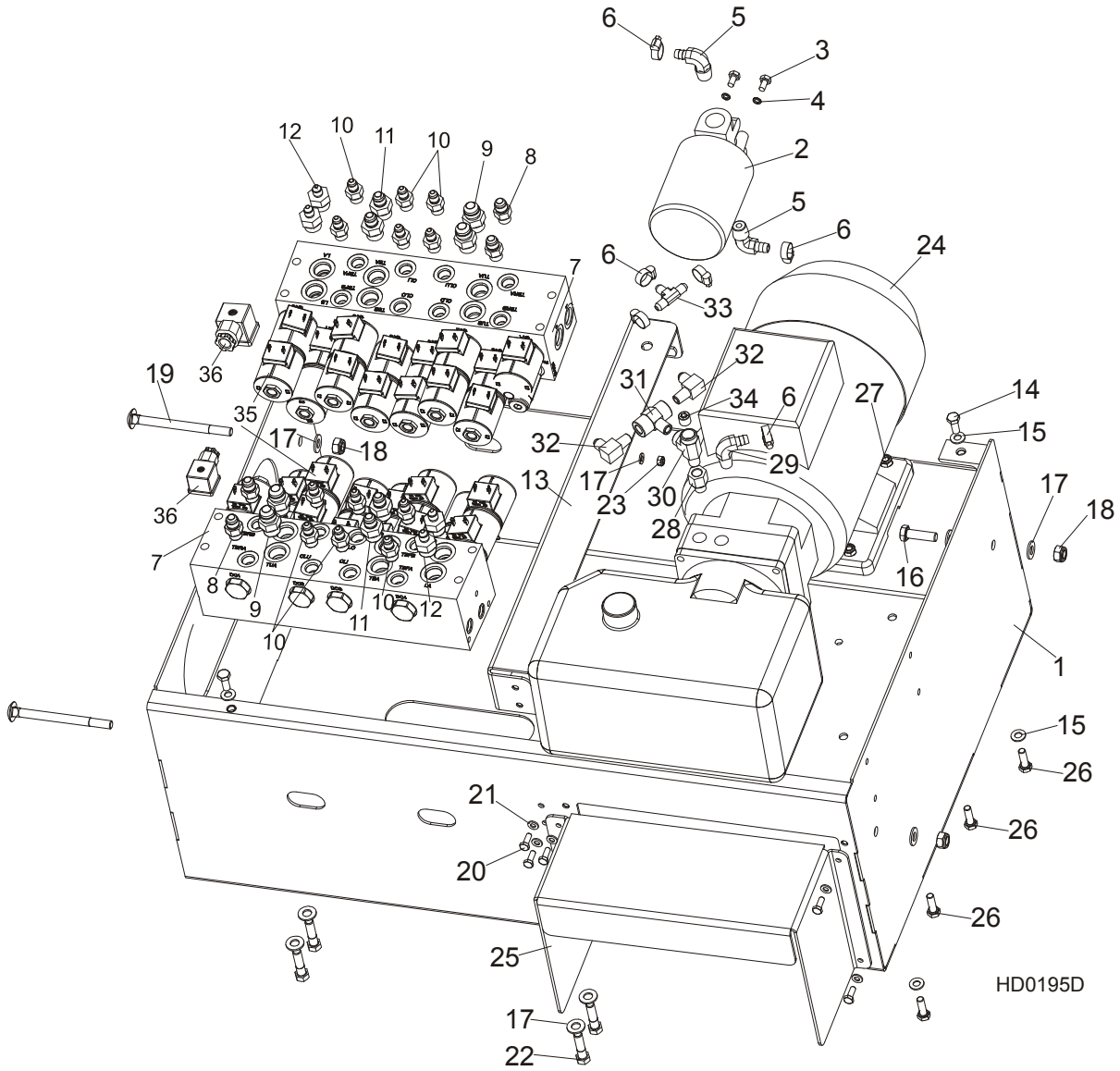

REF.	DESCRIPTION (◆ Indicates Parts Available In Assemblies Only)	PART#	QTY.
	HYDRAULIC CONTROL BOX - LT70M SUPER (AC)	097529	1
1	Box, LT70M Super Hydraulic Control	095690-1	1
2	Manifold, W/Filter	P22683	1
3	Bolt, 1/4-20x1/2 HH	F05005-15	2
4	Washer, M6 Split Lock Zinc	F81053-3	2
5	Fitting, 1/2NPT-3/8 Barb Elbow	P12707	2
6	Clamp, 11/16 Worm	P12739	6
7	Valve, hydr508958-1. 7 Station Exp.12V	025688	2
8	Fitting, 3/8" O-Ring 3/8 JIC	014687	2
9	Fitting, #8SAE- #8JIC	028076	2
10	Fitting, 1/4JIC-3/8 O-Ring	P26284	6

11	Fitting, 8SAE-6JIC	P12703	2	
12	Fitting , 8 SAE-3/8 JIC	036759	2	
13	Bar, LT70M Super Hydraulic Valve Station	095686-1	1	
14	Bolt, M8x20mm, Hex Head,Gr 5.8 Zinc	F81002-4	4	
15	Washer, M8, Flat, Zinc	F81054-1	8	
16	Bolt, M10x35-8.8 Fe/Zn5 PN-M/82105	F81003-17	2	
17	Washer, M10, Flat, Zinc	F81055-1	14	
18	Nut, M10, Nylon Hex Zinc Lock	F81033-1	4	
19	Bolt, M10x120 8.8 Carriage	F81003-33	2	
20	Bolt, M6x16 8.8 Fe/Zn5 PN-M/82105	F81001-15	8	
21	Washer, M6, Flat, Zinc	F81053-1	10	
22	Bolt, 3/8-16x1 1/2 HH	F05007-3	8	
23	Nut, M6, Nylon Hex Zinc Lock	F81031-2	2	
24	Hydraulic pump w/motor, 4KW 14.5 l/min. AC	500958	1	
	Motor, AC-4kW Hydraulic Pump	092258	1	
	Pump, AC-4kW Hydraulic	097782	1	
	Plate, AC-4kW Hydraulic Connecting	097783	1	
	Seal, AC-4kW Hydraulic Complete	097784	1	
25	Cover, MSuper Hydraulic Box	501434-1	1	
26	Bolt, M8x30mm Hex Head Gr 5.8 Zinc	F81002-7	3	
27	Nut, M8, Hexagon, Nylon Lock Zinc	F81032-2	3	
28	Fitting, 6SAE Male-1/4NPT Female	014686	1	
29	Fitting, 3/8NPT-3/8 Barb Elbow	P12708	1	
30	Fitting, 1/4NPT Male Run Tee	P09141	1	
31	Fitting, 1/4NPT Branch Tee	015486	1	
32	Fitting, 3/8JIC-1/4NPT 90L	015491	2	
33	Fitting, 3/8 Barb Tee	015485	1	
34	Fitting, 1/4 NPT Socket Pipe Plug	096221	1	
35	Coil, Hydraulic Valve	025835	30	
36	VALVE CONNECTOR, WITH BUILT-IN LED	094556	30	
	COVER, LT70M SUPER HYDRAULIC BOX	097528-1	1	

9.3 Hydraulic & Wireless Control Box

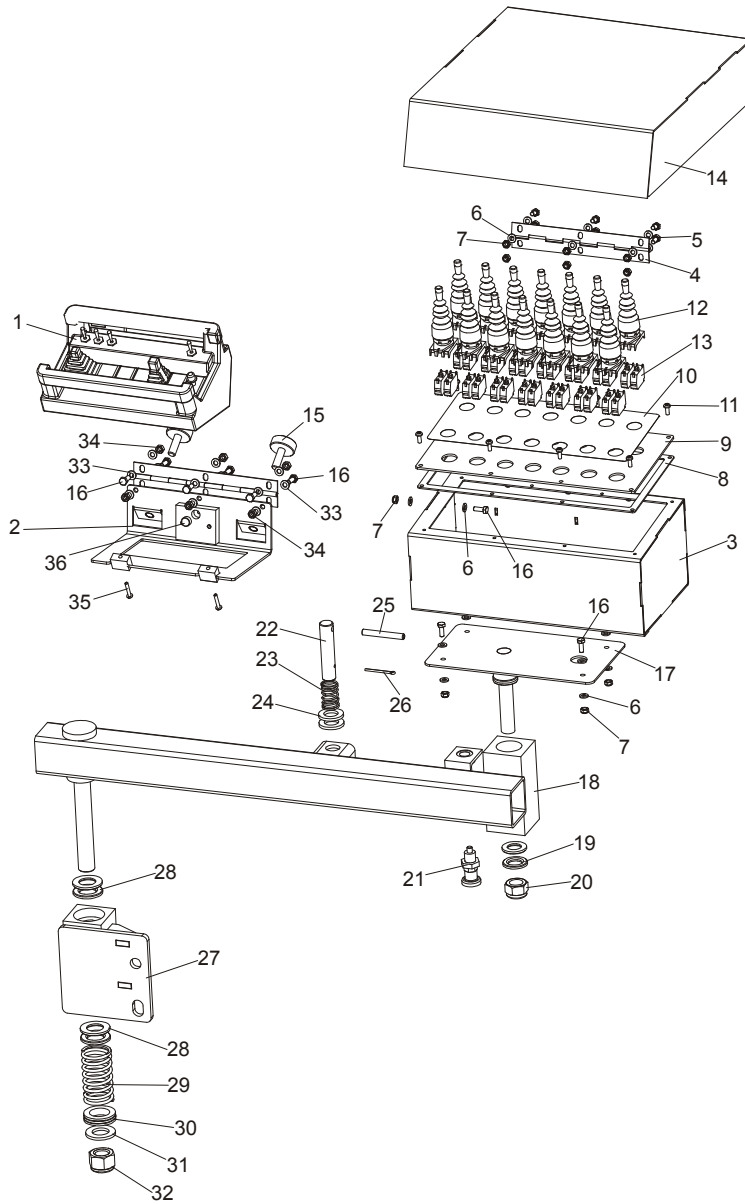

REF.	DESCRIPTION (◆ Indicates Parts Available In Assemblies Only)	PART#	QTY.
	BOX ASSEMBLY, LT70M SUPER HYDRAULIC CONTROL	096485	1
1	Box, LT70MAC Super Wireless Control	098917	1
1	Box, LT70MDC Super Wireless Control	097314	1
2	Box, Super Remote Control Box	099187-1	1
	Box, LT70M Super Hydraulic Control Complete	096999	1
3	Box, LT70M Super Hydraulic Control Box	097005-1	1
4	Hinge, Cover Zinc	088257-1	1
5	Bolt, M6x12mm Hex Head Zinc	F81001-7	6
6	Washer, M6, Flat, Zinc	F81053-1	23
7	Nut, M6, Nylon Hex Zinc Lock	F81031-2	13
8	Gasket, 9.5m Front Panel	089998	1
9	Panel Assembly, Hydraulic 9.5m Front	090356-1	1
10	Decal, Front Panel	095692	1

11	Bolt, #10-24x1/2 Ph Pan Hd, Type 23	F05015-17	8	
12	Joystick, PMJN8T3, 2-position	096928	14	
13	Contact, ZBE 101	087817	28	
14	Cover, LT70M Super Hydraulic & Wireless Control Box	096941-1	1	
15	Bumper	092839	1	
16	Bolt, M6x16-5.8 Hex Head Full Thread Zinc	F81001-15	13	
17	Support, LT70M Super Control Box	096489-1	1	
18	Arm, Control Box	096480-1	1	
19	Washer, 21 PN-83/M-82039	F81059-21	4	
20	Nut, M20, Nylon Hex Zinc Lock	F81037-2	1	
21	Pin, Outrigger Detent	090197	1	
22	Pin, Outrigger Pull	087012-1	1	
23	Spring, 21x38x2 Zinc	087040	1	
24	Washer, 21 Flat Zinc	F81059-2	2	
25	Pin, 8x65 Roll Zinc	F81046-1	1	
26	Pin, 4x25 Cotter	F81043-2	1	
27	Bracket, Control Box	096690-1	1	
28	Washer, 25 PN-83/M-82039	F81059-22	4	
29	Spring, 40x80x4,5 Zinc	093435	1	
30	Bearing, 51106 Thrust	097274	1	
31	Washer, 25 Flat Zinc	F81061-3	1	
32	Nut, M24-8 Zinc Lock	F81039-8	1	
33	Washer, 6.4 Flat Zinc	F81053-1	12	
34	Nut, M6-8 Hex Zinc	F81031-1	6	
35	Magnet, Orange Painted	S10519-1	1	

9.4 Wireless Control Assembly (Option)

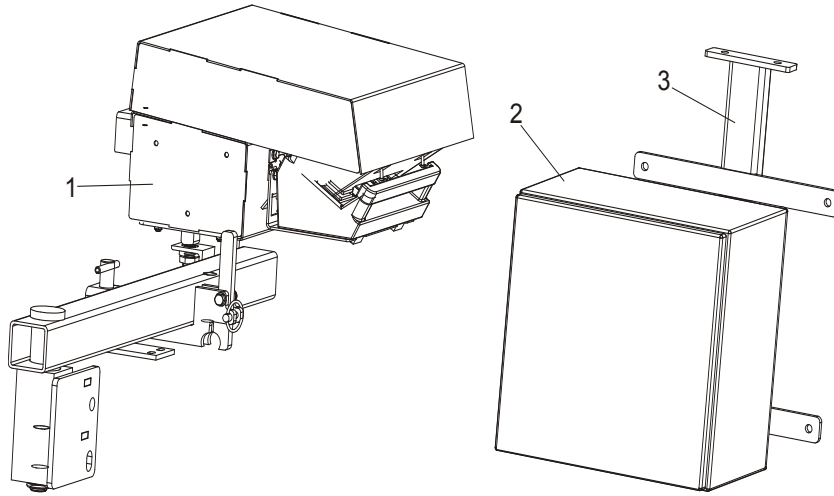

70_007a

REF.	DESCRIPTION (◆ Indicates Parts Available In Assemblies Only)	PART#	QTY.
1	BOX ASSEMBLY, LT70M SUPER HYDRAULIC CONTROL	096999	1
2	ELECTRIC BOX, WIRELESS CONTROL	096989	1
3	BRACKET, WIRELESS CONTROL ELECTRIC BOX	096930-1	1

9.5 Hydraulic Log Loader, S/M Frame

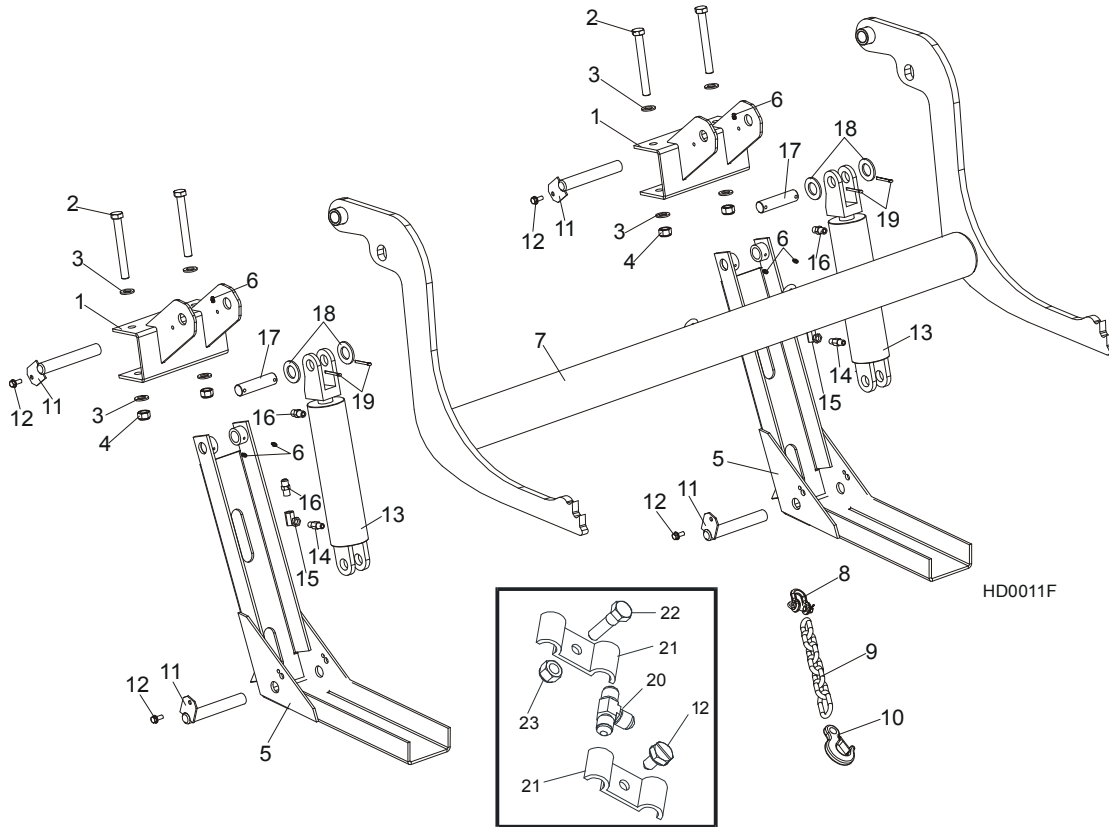

REF.	DESCRIPTION (◆ Indicates Parts Available In Assemblies Only)	PART #	QTY.
	LOADER KIT, HYDRAULIC LOG, S/M FRAME	092863	1
1	Bracket, Hydraulic Log Loader	087938-1	1
2	Bolt, M16x140-8.8 Hex Head Zinc	F81006-4	4
3	Washer, 17 Flat Zinc	F81058-1	8
4	Nut, M16-8 Hex Nylon Zinc Lock	F81036-2	4
5	Channel, Hydraulic Log Loading Foot Complete	090049	2
6	Fitting, 3/16x3/16 Straight Grease	P04107	6
7	Arm, Hydraulic Log Loading Complete	090044	1
8	Shackle, M-WL. .63	086540	1
9	Chain, Hydraulic Log Loader Safety	A04376	1
10	Hook, 5/8 Safety Chain	P12075	1
11	Pin, Turner Arm	W09446-1	4
12	Screw, 5/16-18x3/4 Self-Tapping	F05015-30	4
	Cylinder Assy, Log Loading Super	015562	2
13	CYLINDER, CJ-S95-16-70/32/203 HYDRAULIC	088680	1
14	Fitting, 1/4NPT Velocity Fuse 5.0GPM	015750	2
15	Fitting, 1/4NPT-1/4JIC Swivel Elbow	P12199	2
16	Fitting, 3/8JIC-1/4NPT Straight	015560	4
17	Pin, Cylinder Hydraulic	086979-1	2
18	Washer, 28 Flat Zinc	F81061-1	4
19	Pin, 5x40 Cotter	F81043-31	4



HYDRAULIC SYSTEM

Hydraulic Log Loader, S/M Frame

20	Fitting, 3/8 Barb Tee	015485	1	
21	Clamp, 3/8 Hose	016041	2	
22	Bolt, 5/16-18x1 Hex Head Zinc Grade 2	F05006-1	1	
23	Nut, 5/16-18 Nylon Zinc Lock	F05010-58	1	

9.6 Hydraulic Log Loader for "M" Super Frames

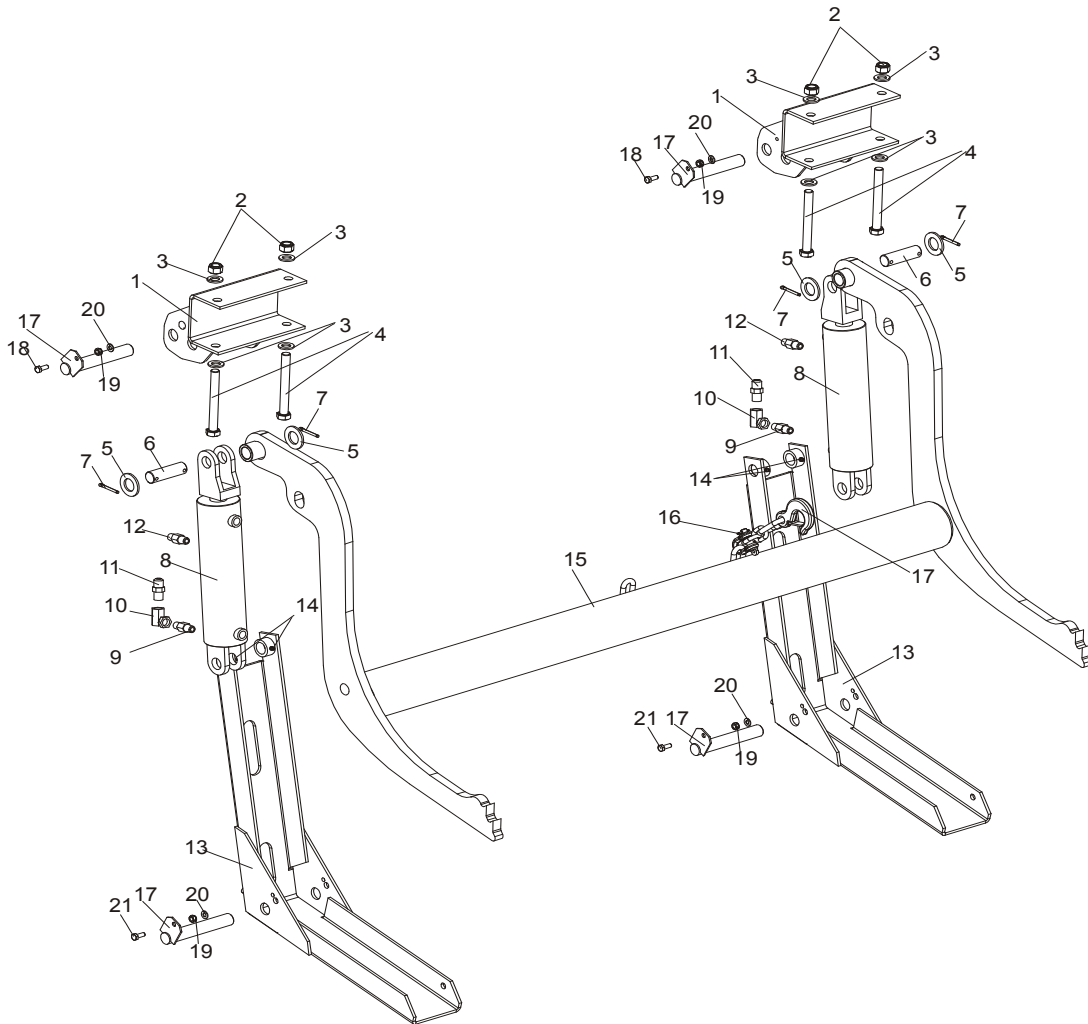

REF.	DESCRIPTION (◆ Indicates Parts Available In Assemblies Only)	PART #	QTY.
	LOG LOADER, "M" SUPER FRAME	500750	1
1	BRACKET, LOG LOADER ("M" SUPER FRAME)	500747-1	2
2	NUT, M16-8 HEX NYLON ZINC LOCK	F81036-2	4
3	WASHER, 17 SPLIT LOCK ZINC	F81058-1	8
4	BOLT, M16X140 HEX HEAD ZINC	F81006-4	4
5	WASHER, 28 FLAT ZINC	F81061-1	4
6	PIN, HYDRAULIC CYLINDER ZINC-PLATED	086979-1	2
7	PIN, S-Fe 5x40 PN-M/82001 COTTER	F81043-31	4
	LOG LOADER CYLINDER	015562	2
8	CYLINDER, CJ-S95-16-70/32/203 HYDRAULIC	088680	1
9	FITTING, 1/4NPT VELOCITY FUSE 4.0GPM	015750	2
10	FITTING, 1/4NPT-1/4JIC SWIVEL ELBOW	P12199	2
11	FITTING, 3/8JIC-1/4NPT STRAIGHT	015560	2
12	FITTING, 3/8JIC-1/4NPT STRAIGHT	015560	2
	COMPLETE LOG LOADER FOOT, 9.5 M FRAME	090049	2
13	FOOT WELDMENT, LOG LOADER PTD (9.5 M FRAME)	090048-1	2



HYDRAULIC SYSTEM

Hydraulic Log Loader for "M" Super Frames

14	FITTING, 3/16X3/16 STRAIGHT GREASE	P04107	4	
	LOG LOADER ARM, "M" SUPER FRAME	500758	1	
15	LOG LOADER WELDMENT, 9.5 M FRAME	090006-1	1	
16	SHACKLE, M-D .63 PN-92/W-89180	086540	1	
17	CHAIN W/HOOK	500756	1	
18	SCREW, 5/16-18 x 3/4 SELF-TAPPING	F05015-30	2	
19	WASHER, 8.4 FLAT ZINC	F81054-1	4	
20	NUT, M8 8 HEX NYLON ZINC LOCK	F81032-2	4	
21	BOLT, M8X20 8.8 HEX HEAD FULL THREAD ZINC	F81002-4	2	

9.7 Hydraulic Log Turner

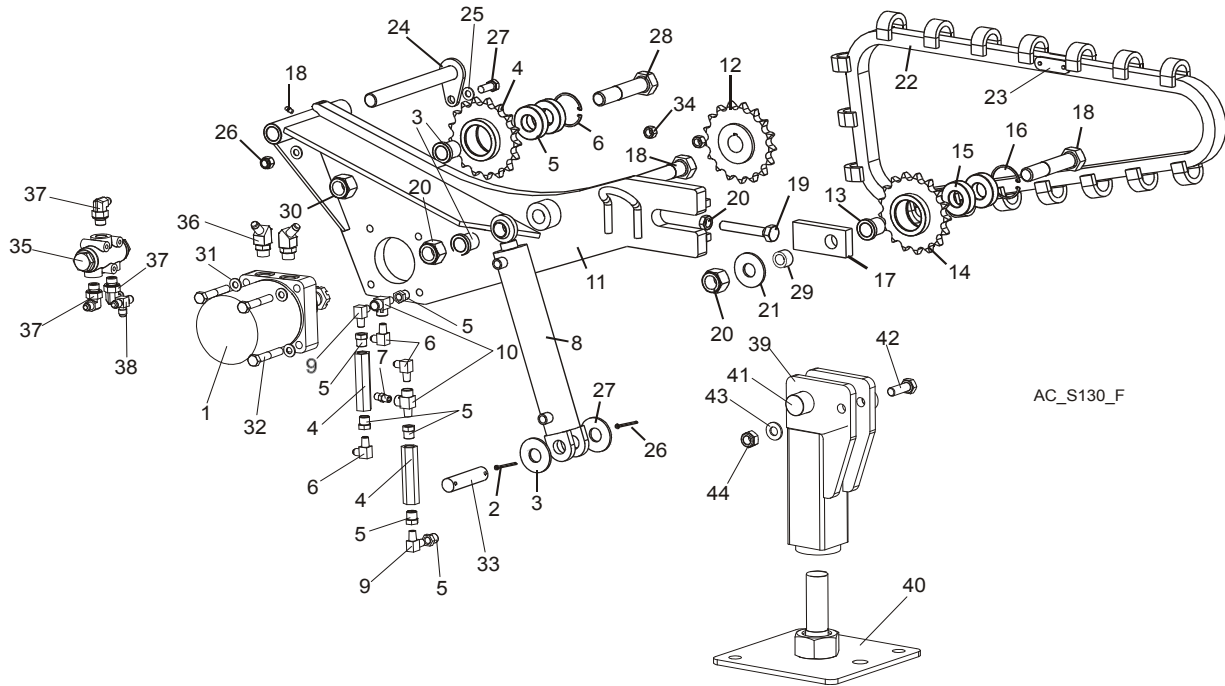

REF.	DESCRIPTION (◆ Indicates Parts Available In Assemblies Only)	PART #	QTY.
	CHAIN LOG TURNER - COMPLETE	505614	1
1	MOTOR, TG0475US080AABP HYDRAULIC	007331	1
2	PIN, S-Fe 5x40 COTTER	F81043-31	2
3	WASHER, 28 FLAT ZINC	F81061-1	2
	CYLINDER W/VALVE & FITTINGS	515892	1
4	VALVE, SIDE SUPPORT SEQUENCE	015484	2
5	FITTING, 3/8" NPT X 1/4" NPT REDUCER	015490	6
6	FITTING, 3/8JIC-1/4NPT 90L	015491	3
7	FITTING, 3/8JIC-1/4NPT STRAIGHT	015560	1
8	CYLINDER, 2X10 ROD END WELDED 16"	034267	1
9	FITTING, 1/4NPT MALE PIPE ELBOW	P09140	2
10	FITTING, 1/4NPT MALE RUN TEE	015486	2
	CHAIN TURNER - METRIC	095660	1
11	PLATE WELDMENT, CHAIN LOG TURNER	095662-1	1
12	SPROCKET, CHAIN TURNER	092339	1
13	BUSHING, CHAIN TURNER	095663-1	3
	SPROCKET, CHAIN TURNER - COMPLETE	092399	2
14	SPROCKET W/HUB	093290	1
15	BEARING, 6206 25	093292	2
16	RING, W62 INSIDE RETAINING	F81090-1	1
17	PLATE, CHAIN TENSION	095664-1	1
18	FITTING, M6 TYPE A STRAIGHT GREASE	086280	1
19	BOLT, M16x100-8.8 HEX HEAD FULL THREAD ZINC	F81006-2	1
20	NUT, M16-5.8 HEX ZINC	F81036-1	1

21	WASHER, 25X63 ZINC-PLATED	088585-1	1	
22	CHAIN, LOG TURNER	093423	1	
23	LINK, MASTER	093427	1	
24	PIN WELDMENT, TURNER MOUNT - COMPLETE	095666-1	1	
25	WASHER, 10.5 FLAT ZINC	F81055-1	2	
26	NUT, M10-8-B HEX NYLON ZINC LOCK	F81033-1	1	
27	BOLT, M10x35-8.8 HEX HEAD FULL THREAD ZINC	F81003-17	1	
28	BOLT, M24x120-8.8 HEX HEAD	F81009-4	3	
29	BUSHING, CHAIN TURNER	095643-1	1	
30	NUT, M24-8-A HEX NYLON ZINC LOCK	F81039-8	3	
31	WASHER, Z12.2 SPLIT LOCK ZINC	F81056-2	4	
32	BOLT, M12x75-8.8 HEX HEAD ZINC	F81004-21	4	
33	PIN, HYDRAULIC CYLINDER ZINC-PLATED	086979-1	1	
34	NUT, M12-8-B HEX ZINC	F81034-1	4	
	OIL FLOW DIVIDER W/FITTINGS	094383	1	
35	DIVIDER, MTDA O8-016M 1/2 / 1/2 OIL FLOW	088191	1	
36	FITTING, #10SAE-3/8JIC 45 ELBOW	034538	2	
37	FITTING, 90 18X1.5 9/16-18 JIC ELBOW	089992	3	
38	FITTING, 3/8JIC TEE	015487	1	
	SUPPORT, LOG TURNER - COMPLETE	099975	1	
39	TURNER SUPPORT UPPER PART	099932-1	1	
40	TURNER SUPPORT LOWER PART (ZINC-PLATED)	099969-1	1	
41	PIN WELDMENT, TURNER SUPPORT MOUNT (ZINC-PLATED)	099970-1	1	
42	BOLT, M10x30-5.8 HEX HEAD FULL THREAD ZINC	F81003-2	1	
43	WASHER, 10.5 FLAT ZINC	F81055-1	1	
44	NUT, M10-8-B HEX NYLON ZINC LOCK	F81033-1	1	

9.8 Hydraulic Log Side Supports (for Stationary Sawmills)

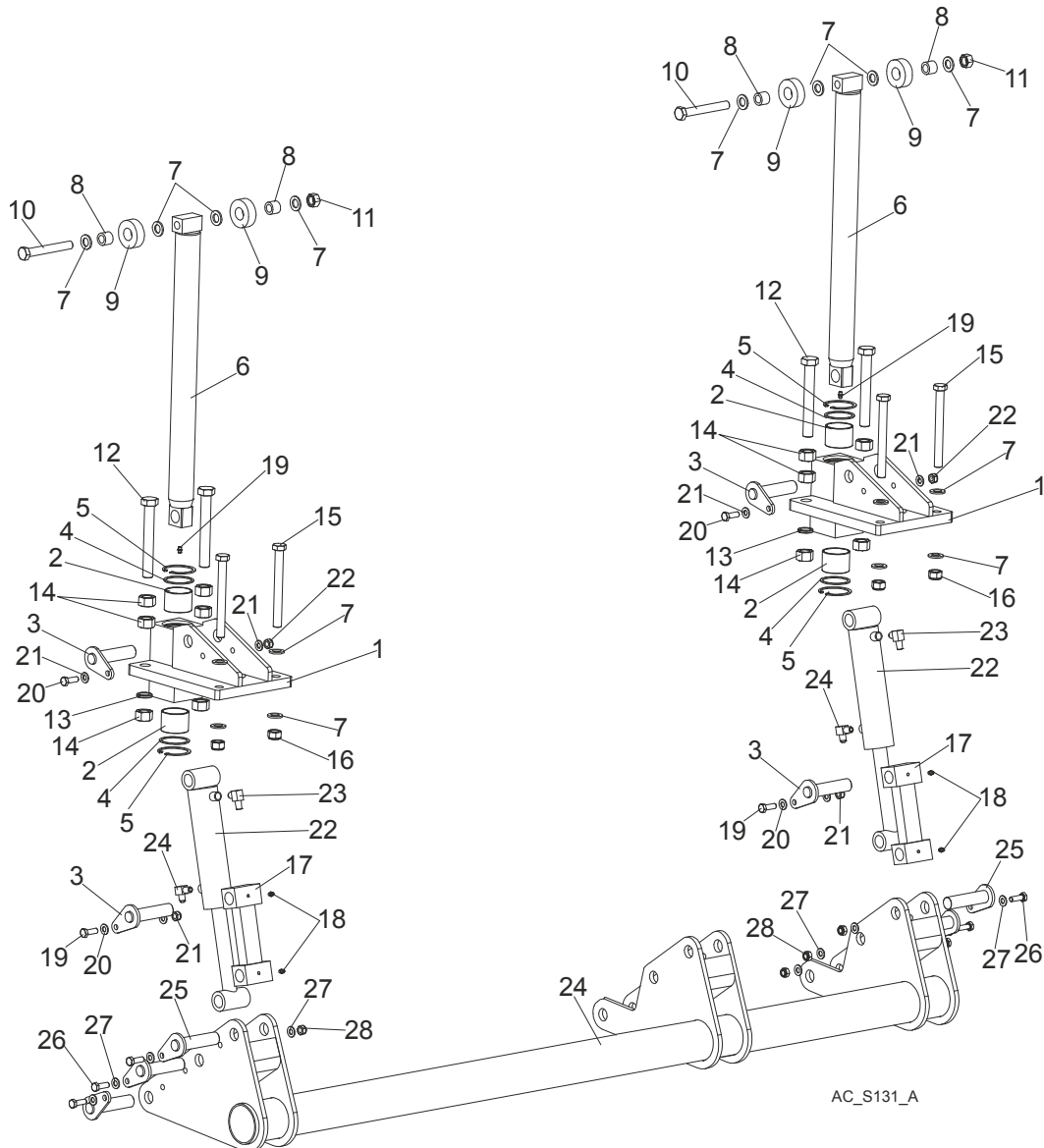

REF.	DESCRIPTION (◆ Indicates Parts Available In Assemblies Only)	PART#	QTY.
	SUPPORT, AHS/DHS STATIONARY VERTICAL SIDE COMPLETE	519258	1
	SUPPORT, STATIONARY VERTICAL LOG SIDE	508957	2
1	Mount Weldment, LT70/300 Vertical Side Support Upper	508958-1	1
2	Bushing, 5040BS Non-Greasable	088660	2
3	Pin Weldment, Vertical Side Support Zinc-Plated	091197-1	2
4	Ring, LT70/300 Vertical Side Support Zinc-Plated	094004-1	2
5	Ring, 62W Inside Retaining	F81090-1	2
6	Rod Weldment, LT70/300 Vertical Side Support Complete	094011-1	1
7	Washer, 17 Flat Zinc	F81058-1	12
8	Bushing, LT70/300 Vertical Side Support Bronze	094012	2
9	Roller, LT70/300 Vertical Side Support Zinc-Plated	094013-1	2
10	Bolt, M16x120 -8.8 Hex Head Zinc	F81006-25	1
11	Nut, M16-5.8 Hex Zinc	F81036-1	1
12	Bolt, ISO 4017 M20x150 8.8 Zinc-Plated	F81007-3	2



HYDRAULIC SYSTEM

Hydraulic Log Side Supports (for Stationary Sawmills)

13	Washer, 20.5 Split Lock Zinc	F81059-1	2	
14	Nut, M20-8 Hex Zinc	F81037-1	6	
15	Bolt, M16x160 -8.8 Hex Head Zinc	F81006-20	2	
16	Nut, M16-8 Hex Nylon Zinc Lock	F81036-2	2	
17	Link Weldment, LT300 Vertical Side Support	094016-1	1	
18	Fitting, M6 Grease	086280	3	
19	Bolt, M10x30-5.8 Hex Head Full Thread Zinc	F81003-2	2	
20	Washer, 10.5 Flat Zinc	F81055-1	4	
21	Nut, M10-8-B Nylon Hex Zinc Lock	F81033-1	2	
22	Cylinder, 28/150 1/4 NPT Port Hydraulic	094002	1	
23	Fitting, 3/8JIC-1/4NPT 90L	015491	2	
24	Mount Weldment, AHS/DHS Vertical Side Support Lower	519257-1	1	
25	Pin Weldment, Vertical Side Support Zinc-Plated	091197-1	6	
26	Bolt, M10x30-5.8 Hex Head Full Thread Zinc	F81003-2	6	
27	Washer, 10.5 Flat Zinc	F81055-1	12	
28	Nut, M10-8-B Nylon Hex Zinc Lock	F81033-1	6	

9.9 Hydraulic Log Side Supports (for Mobile Sawmills)

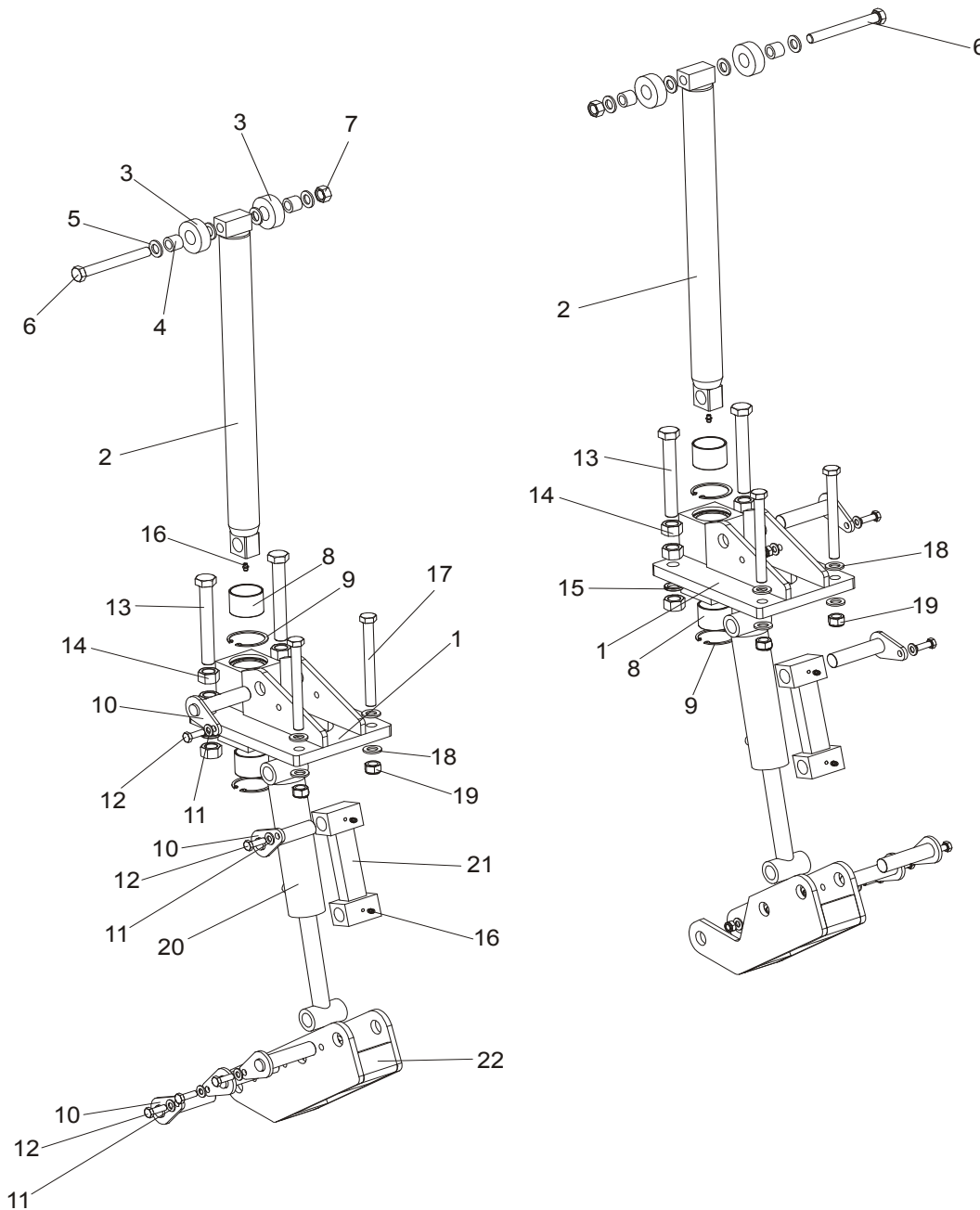

REF.	DESCRIPTION (◆ Indicates Parts Available In Assemblies Only)	PART #	QTY.
	SUPPORT, LT70/300 VERTICAL LOG SIDE (2)	094388	
1	Mount Weldment, LT70/300 Vertical Side Support Upper	508958-1	1
2	Rod Weldment, LT70/300 Vertical Side Support Complete	094011-1	1
3	Roller, LT70/300 Vertical Side Support Zinc-Plated	094013-1	2
4	Bushing, LT70/300 Vertical Side Support Bronze	094012	2
5	Washer, 17 Flat Zinc	F81058-1	4
6	Bolt, M16x140-8.8 Hex Head Zinc	F81006-4	1
7	Nut, M16-5.8 Hex Zinc	F81036-1	1
8	Bushing, 5040BS Non-Greasable	088660	1
9	Ring, 62W Inside Retaining	F81090-1	2



HYDRAULIC SYSTEM

Hydraulic Log Side Supports (for Mobile Sawmills)

10	Pin Weldment, Vertical Side Support Zinc-Plated	091197-1	5	
11	Washer, 10.5 Flat Zinc	F81055-1	5	
12	Bolt, M10x30-5.8 Hex Head Full Thread Zinc	F81003-2	5	
13	Bolt, ISO 4017 M20x150 8.8 Zinc-Plated	F81007-3	2	
14	Nut, M20-8 Hex Zinc	F81037-1	6	
15	Washer, 20.5 Split Lock Zinc	F81059-1	2	
16	Fitting, M6 Grease	086280	2	
17	Bolt, M16x160 -8.8 Hex Head Zinc	F81006-20	2	
18	Washer, 17 Flat Zinc	F81058-1	4	
19	Nut, M16-8 Hex Nylon Zinc Lock	F81036-2	2	
20	Cylinder, 28/150 1/4 NPT Port Hydraulic	094002	1	
21	Link Weldment, LT300 Vertical Side Support	094016-1	1	
22	Mount Weldment, LT300 Vertical Side Support Lower	094387-1	1	
	SUPPORT, LT70/300 VERTICAL LOG SIDE	094010		
1	Mount Weldment, LT70/300 Vertical Side Support Upper	508958-1	1	
2	Rod Weldment, LT70/300 Vertical Side Support Complete	094011-1	1	
3	Roller, LT70/300 Vertical Side Support Zinc-Plated	094013-1	2	
4	Bushing, LT70/300 Vertical Side Support Bronze	094012	2	
5	Washer, 17 Flat Zinc	F81058-1	4	
6	Bolt, M16x140-8.8 Hex Head Zinc	F81006-4	1	
7	Nut, M16-5.8 Hex Zinc	F81036-1	1	
8	Bushing, 5040BS Non-Greasable	088660	1	
9	Ring, 62W Inside Retaining	F81090-1	2	
10	Pin Weldment, Vertical Side Support Zinc-Plated	091197-1	5	
11	Washer, 10.5 Flat Zinc	F81055-1	5	
12	Bolt, M10x30-5.8 Hex Head Full Thread Zinc	F81003-2	5	
13	Bolt, ISO 4017 M20x150 8.8 Zinc-Plated	F81007-3	2	
14	Nut, M20-8 Hex Zinc	F81037-1	6	
15	Washer, 20.5 Split Lock Zinc	F81059-1	2	
16	Fitting, M6 Grease	086280	2	
17	Bolt, M16x160 -8.8 Hex Head Zinc	F81006-20	2	
18	Washer, 17 Flat Zinc	F81058-1	4	
19	Nut, M16-8 Hex Nylon Zinc Lock	F81036-2	2	
20	Cylinder, 28/150 1/4 NPT Port Hydraulic	094002	1	
21	Link Weldment, LT70/300 Vertical Side Support	094016-1	1	
22	Mount Weldment, LT70/300 Vertical Side Support Lower	094387-1	1	

9.10 Hydraulic Pull-Down Clamp

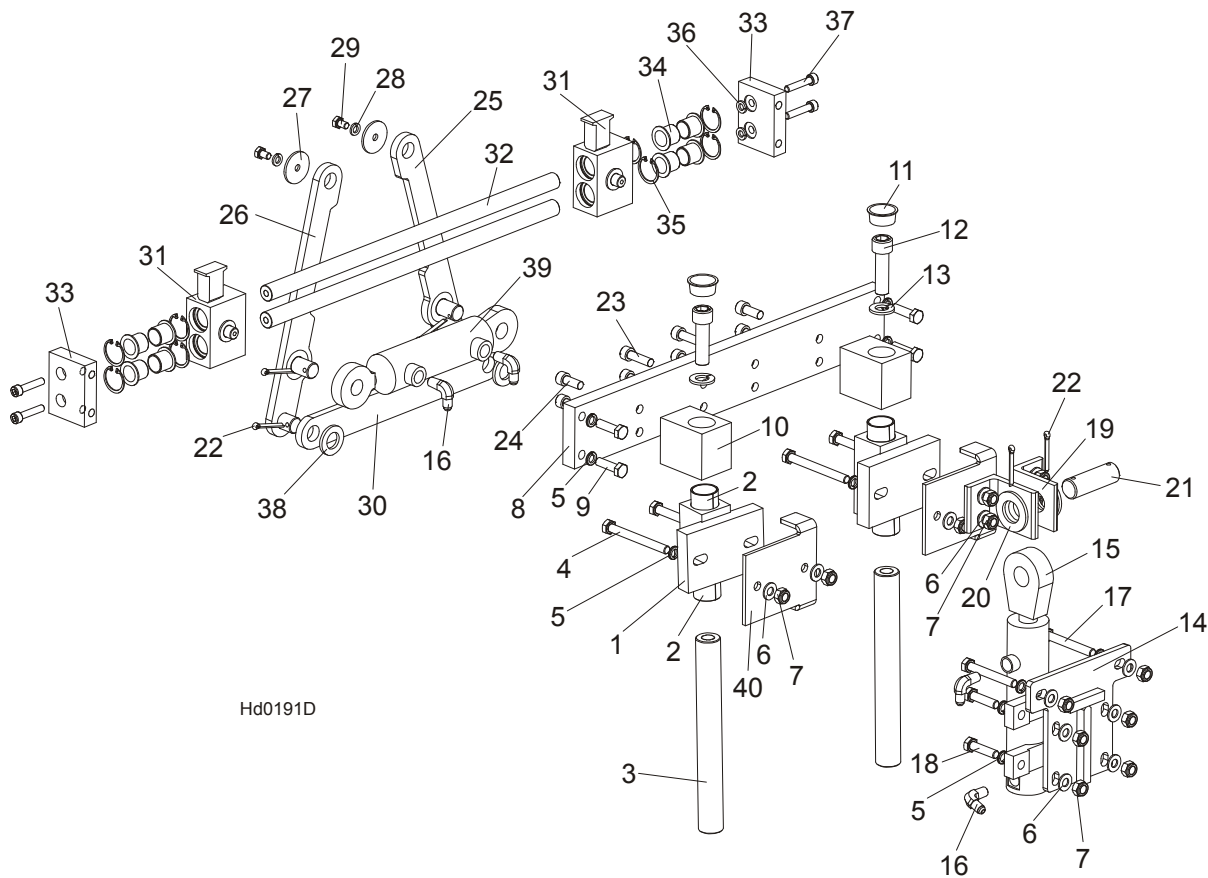

Hd0191D

REF.	DESCRIPTION (◆ Indicates Parts Available In Assemblies Only)	PART #	QTY.
	LEFT HYDRAULIC LOG CLAMP ASSEMBLY, COMPLETE	094129	1
	GUIDE BLOCK W/SELF-LUBRICATING BUSHINGS	090544	2
1	Block Weldment, Log Clamp Guide Ptd	090543-1	2
2	Bushing, 3040BS Self-lubricating	088676	2
3	Pin, Log Clamp Up/Down	088631	2
4	Bolt, M10x95-8.8-B Hex Head Zinc	F81003-71	4
5	Washer, 10.2 Split Lock Zinc	F81055-2	14
6	Washer, 10.5 Flat Zinc	F81055-1	14
7	Nut, M10-8-B Hex Nylon Zinc Lock	F81033-1	14
8	Beam, Log Clamp Main Zinc-plated	094115-1	1
9	Bolt, M10x35-8.8 Hex Head Full Thread Zinc	F81003-17	4
10	Block, Log Clamp Up/Down Painted	094124-1	2
11	Plug, M33 Thread #12428	089839	2
12	Screw, M16x55-8.8 Hex Socket Head Cap Zinc	F81006-18	2
13	Washer, 16.3 Split Lock Zinc	F81058-2	2
14	Plate Weldment, Hydraulic Cylinder Mounting Painted	094094-1	1
15	Cylinder, CJ7F-16/40/22 + UE2-40W Hydraulic	091346	1
16	Fitting, 90° Male Elbow	P09142	2
17	Bolt, M10x75-8.8 Hex Head Zinc	F81003-15	2
18	Bolt, M10x40-8.8 Hex Head Full Thread Zinc	F81003-16	4

19	Bracket, Hydraulic Cylinder Mounting Painted	094127-1	2	
20	Washer, 28 Flat Zinc	F81061-1	2	
21	Pin, 25x75 Zinc-plated	088659-1	1	
22	Pin, S-Zn 5x40 Cotter Zinc	F81043-31	4	
23	Screw, M10x35 8.8 Hex Socket Head Cap Zinc	F81003-56	4	
24	Screw, M10x25 8.8 Hex Socket Head Cap Zinc	F81003-32	4	
25	Link, Log Clamp In/Out Side Zinc-plated (1)	094097-1	1	
26	Link, Log Clamp In/Out Side Zinc-plated (2)	094099-1	1	
27	Washer, Zinc-plated Spacer	094128-1	1	
28	Washer, 8.2 Split Lock Zinc	F81054-4	2	
29	Bolt, M8x12-8.8 Hex Head Full Thread Zinc	F81002-6	2	
30	Arm, Log Clamp In/Out Zinc-plated	094092-1	1	
31	Jaw Weldment, Log Clamp Zinc-plated	094120-1	2	
32	Rod, Log Clamp Jaw Guide	094116	2	
33	Plate, Locking Zinc-plated	094117-1	2	
34	Bushing, JFM-2023-21 Flanged	094113	8	
35	Ring, W 31 Inside Retaining	F81090-15	8	
36	Washer, 8.2 Split Lock Zinc	F81054-4	4	
37	Screw, M8x40-8.8 Hex Socket Head Cap Zinc	F81002-29	4	
38	Washer, 21 Flat Zinc	F81059-2	2	
39	Cylinder SJ2F-16-40/22/80 Hydraulic	093880	1	
40	Bracket, Log Clamp Mount Painted	094098-1	2	

9.11 Hydraulic Log Clamp - Main

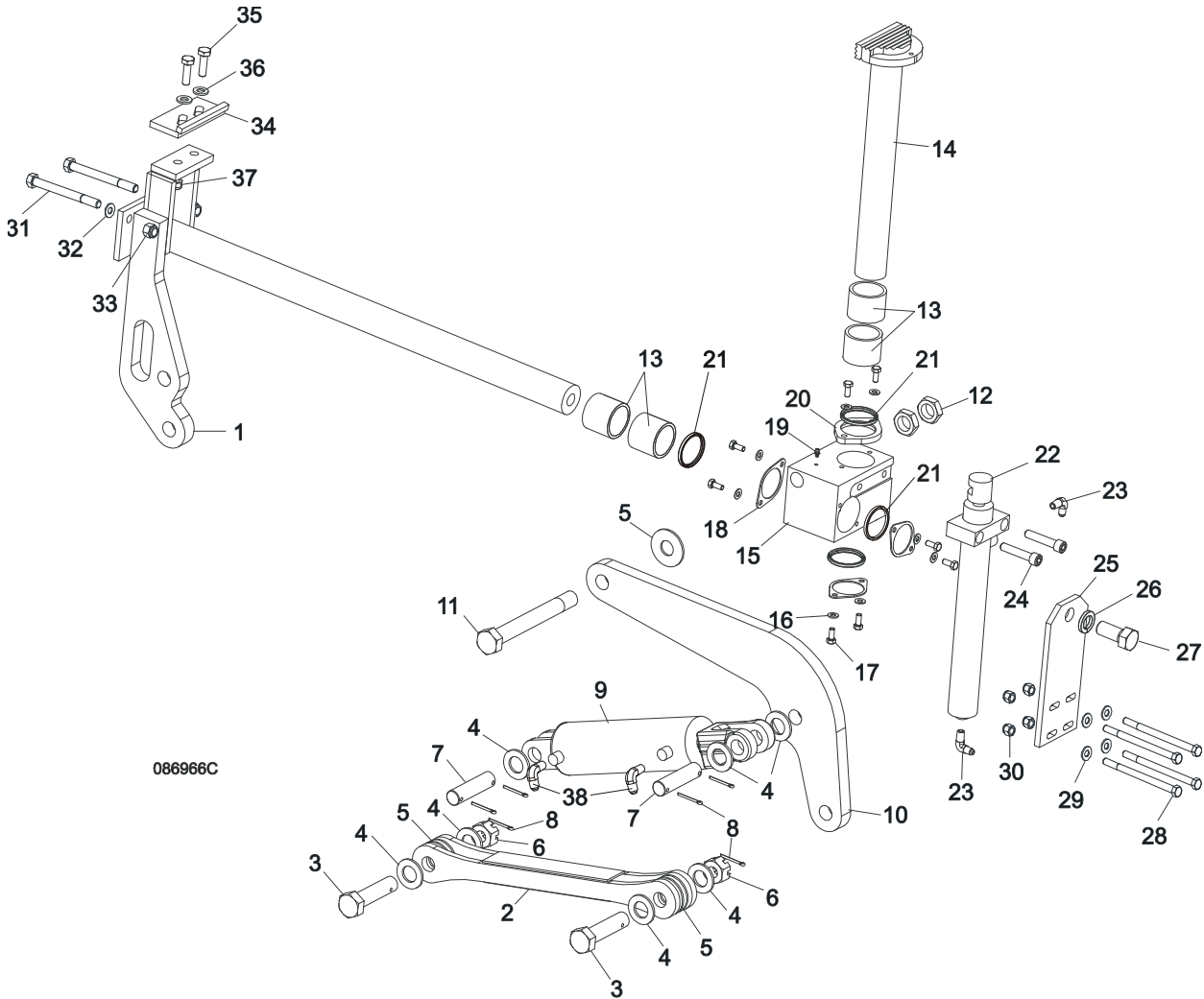

REF.	DESCRIPTION (◆ Indicates Parts Available In Assemblies Only)	PART #	QTY.
	HYDRAULIC LOG CLAMP ASSEMBLY	088658	1
1	Rod Weldment, Log Clamp Slide Ptd	086967-1	1
2	Arm Weldment, Hydraulic Clamp Link Ptd	086963-1	1
3	Pin, B 24x95/85-Clevis Zinc	F81049-2	1
4	Washer, 25 Flat Zinc	F81061-3	8
5	Washer, 25X63 Zinc-Plated	088585-1	5
6	Nut, Z M20-8-B-Slotted Castle Zinc	F81037-3	2
7	Pin, Hydraulic Cylinder Zinc-Plated	086979-1	2
8	Pin, S-Zn 6,3x45 Cotter	F81045-2	6
9	Cylinder, C.J-S96-16-70/32/178 Hydraulic	088589	1
10	Arm, Hydraulic Log Clamp Link Ptd	086974-1	1
11	Bolt, M24x217/39 -8.8-B- Hex Head Zinc	088586-1	1
12	Nut, M24 -04-B- Hex Thin Zinc	F81039-3	2
13	Bushing, 5040BS Self-Lubricating	088660	2

14	Rod Weldment, Log Clamp Vertical Painted	088582-1	1	
15	Block, Log Clamp Steel Ptd	088591-1	1	
16	Washer, 8.4 Flat Zinc	F81054-1	8	
17	Bolt, M8x20-8.8-B-Hex Head Full Thread Zinc	F81002-4	8	
18	Flange, Clamp Rod Wiper Ptd	088887-1	3	
19	Fitting, 3/16" Straight Grease	P04107	1	
20	Flange, Clamp Rod Wiper Ptd	088887-1	1	
21	Wiper, ZZ 50x60x7 Log Clamp Rod	088587	1	
22	Cylinder, CJ-S169-16-40/22/254 Hydraulic	088590	1	
23	Fitting, 1/4" NPT - 1/4" JIC Male Elbow	P09142	2	
24	Screw, M12x55 -8.8-B-Hex Socked Head Cap Zinc	F81004-23	2	
25	Plate, Log Clamp Mount Ptd	086975-1	1	
26	Washer, Z 22,5 Split Lock	F81059-4	1	
27	Bolt, M22x1,5x40 -8.8-B-Hex Head Full Thread Zinc	F81009-1	1	
28	Bolt, M10 x 125-8.8 Hex Head Zinc	F81003-18	4	
29	Washer, 10.5 Flat Zinc	F81055-1	8	
30	Nut, M10-8-B Hex Nylon Zinc Lock	F81033-1	4	
31	Bolt, M12x130-8.8-Hex Head Zinc	F81004-36	2	
32	Washer, 13 Flat Zinc	F81056-1	2	
33	Nut, M12-8 Hex Zinc	F81034-1	2	
	STOP KIT, CLAMP	K09485	1	
34	Stop Wldmt, Hydraulic Log Clamp Ptd	086980-1	1	
35	Bolt, M12 x 40 8.8 Hex Head Full Thread Zinc	F81004-4	2	
36	Washer, 13 Flat Zinc	F81056-1	2	
37	NUT, M12-8 HEX NYLON ZINC LOCK	F81034-2	4	
38	FITTING, 3/8JIC-1/4NPT 90L	015491	2	

9.12 Hydraulic Log Side Supports (Super Version)

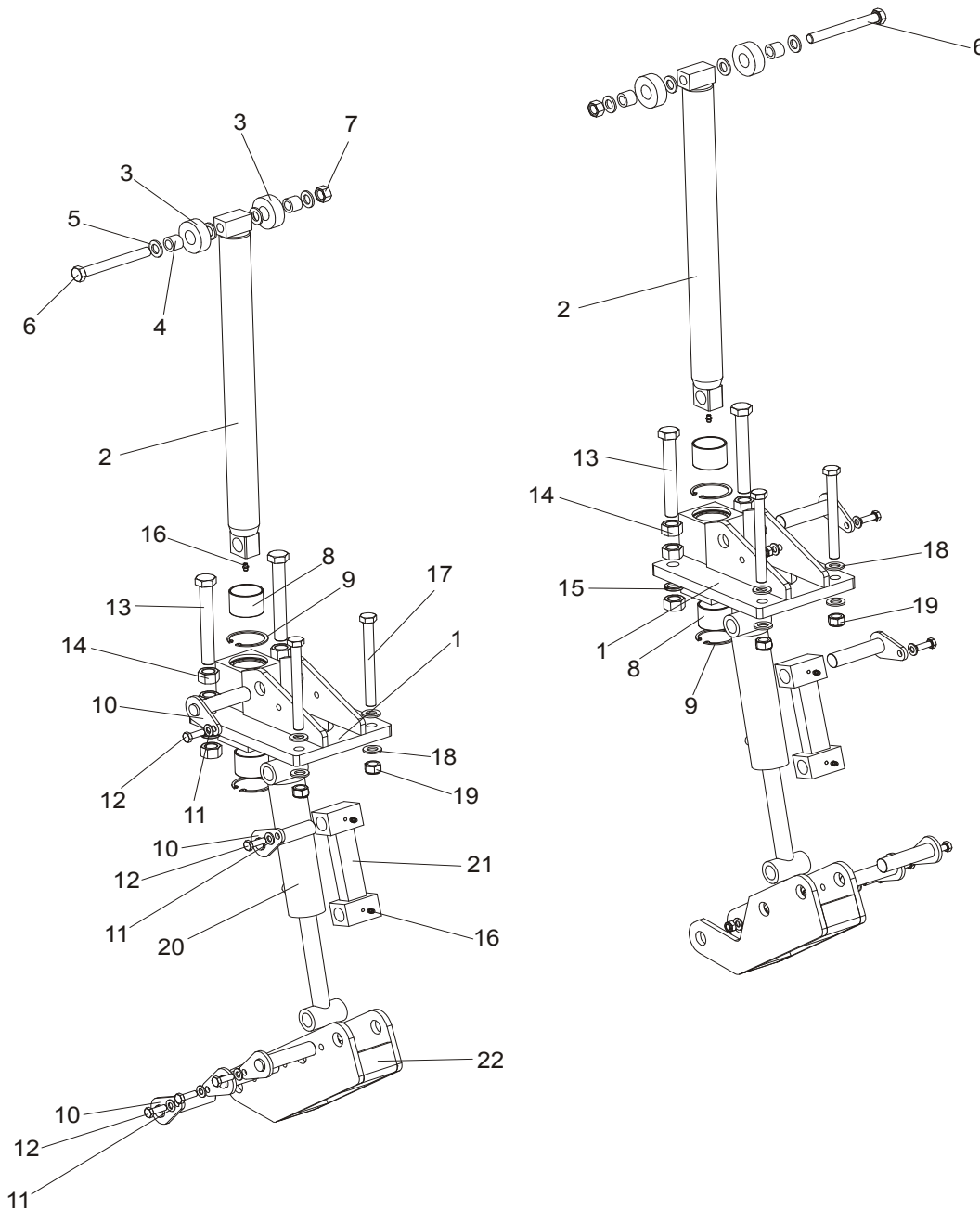

REF.	DESCRIPTION (◆ Indicates Parts Available In Assemblies Only)	PART #	QTY.
	SUPPORT, LT70/300 VERTICAL LOG SIDE (2)	094388	
1	Mount Weldment, LT70/300 Vertical Side Support Upper	508958-1	1
2	Rod Weldment, LT70/300 Vertical Side Support Complete	094011-1	1
3	Roller, LT70/300 Vertical Side Support Zinc-Plated	094013-1	2
4	Bushing, LT70/300 Vertical Side Support Bronze	094012	2
5	Washer, 17 Flat Zinc	F81058-1	4
6	Bolt, M16x140-8.8 Hex Head Zinc	F81006-4	1
7	Nut, M16-5.8 Hex Zinc	F81036-1	1
8	Bushing, 5040BS Non-Greasable	088660	1
9	Ring, 62W Inside Retaining	F81090-1	2



HYDRAULIC SYSTEM

Hydraulic Log Side Supports (Super Version)

10	Pin Weldment, Vertical Side Support Zinc-Plated	091197-1	5	
11	Washer, 10.5 Flat Zinc	F81055-1	5	
12	Bolt, M10x30-5.8 Hex Head Full Thread Zinc	F81003-2	5	
13	Bolt, ISO 4017 M20x150 8.8 Zinc-Plated	F81007-3	2	
14	Nut, M20-8 Hex Zinc	F81037-1	6	
15	Washer, 20.5 Split Lock Zinc	F81059-1	2	
16	Fitting, M6 Grease	086280	2	
17	Bolt, M16x160 -8.8 Hex Head Zinc	F81006-20	2	
18	Washer, 17 Flat Zinc	F81058-1	4	
19	Nut, M16-8 Hex Nylon Zinc Lock	F81036-2	2	
20	Cylinder, 28/150 1/4 NPT Port Hydraulic	094002	1	
21	Link Weldment, LT300 Vertical Side Support	094016-1	1	
22	Mount Weldment, LT300 Vertical Side Support Lower	094387-1	1	
	SUPPORT, LT70/300 VERTICAL LOG SIDE	094010		
1	Mount Weldment, LT70/300 Vertical Side Support Upper	508958-1	1	
2	Rod Weldment, LT70/300 Vertical Side Support Complete	094011-1	1	
3	Roller, LT70/300 Vertical Side Support Zinc-Plated	094013-1	2	
4	Bushing, LT70/300 Vertical Side Support Bronze	094012	2	
5	Washer, 17 Flat Zinc	F81058-1	4	
6	Bolt, M16x140-8.8 Hex Head Zinc	F81006-4	1	
7	Nut, M16-5.8 Hex Zinc	F81036-1	1	
8	Bushing, 5040BS Non-Greasable	088660	1	
9	Ring, 62W Inside Retaining	F81090-1	2	
10	Pin Weldment, Vertical Side Support Zinc-Plated	091197-1	5	
11	Washer, 10.5 Flat Zinc	F81055-1	5	
12	Bolt, M10x30-5.8 Hex Head Full Thread Zinc	F81003-2	5	
13	Bolt, ISO 4017 M20x150 8.8 Zinc-Plated	F81007-3	2	
14	Nut, M20-8 Hex Zinc	F81037-1	6	
15	Washer, 20.5 Split Lock Zinc	F81059-1	2	
16	Fitting, M6 Grease	086280	2	
17	Bolt, M16x160 -8.8 Hex Head Zinc	F81006-20	2	
18	Washer, 17 Flat Zinc	F81058-1	4	
19	Nut, M16-8 Hex Nylon Zinc Lock	F81036-2	2	
20	Cylinder, 28/150 1/4 NPT Port Hydraulic	094002	1	
21	Link Weldment, LT70/300 Vertical Side Support	094016-1	1	
22	Mount Weldment, LT70/300 Vertical Side Support Lower	094387-1	1	

9.13 Hydraulic Toe Board

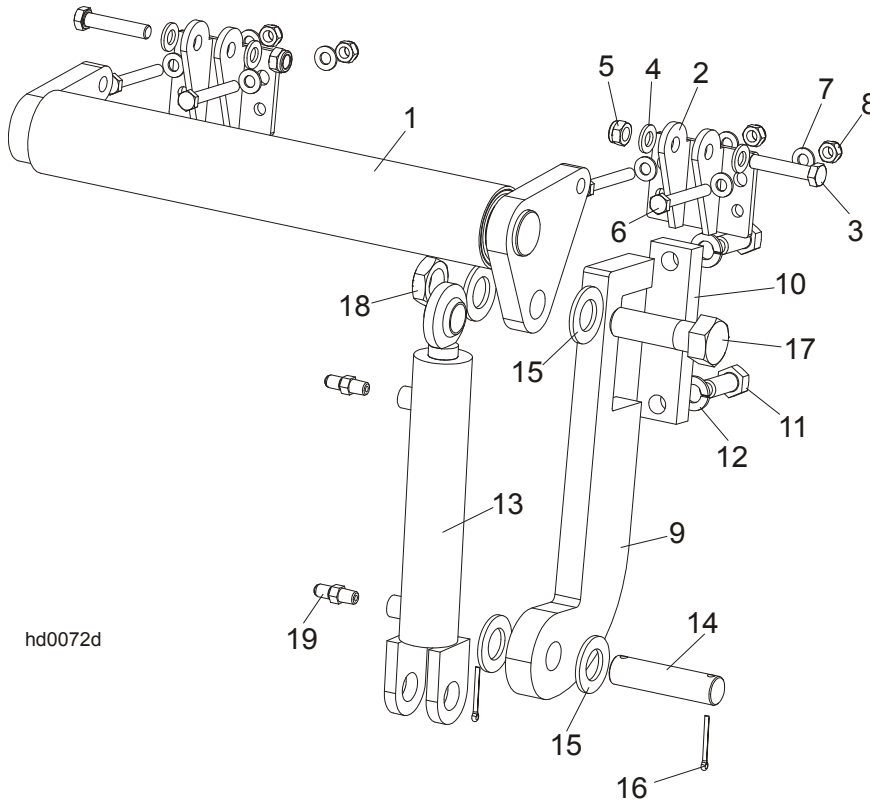

REF.	DESCRIPTION (◆ Indicates Parts Available In Assemblies Only)	PART#	QTY.
	HYDRAULIC TOE BOARD - REAR	092634	1
1	Toe Board Weldment, Hydraulic - Rear	086253-1	1
2	Bracket, Hydraulic Toe Board	087903-1	4
3	Bolt, M12x60mm Hex Head Zinc Grade 8.8	F81004-5	4
4	Washer, M12 Flat Zinc	F81056-1	8
5	Nut, M12 Hex Nylon Zinc Lock	F81034-2	4
6	Bolt, M10x75-8.8 Hex Head Zinc	F81003-15	8
7	Washer, M10 Flat Zinc	F81055-1	16
8	Nut, M10 Hex Nylon Zinc Lock	F81033-1	8
9	Bracket, Hydraulic Toeboard Mount	087729-1	2
10	Plate, Hydraulic Toeboard Mount	090086-1	2
11	Bolt, M16x40mm Hex Head Full Thread Zinc Grade 5.8	F81006-13	4
12	Washer, 16.3 Split Lock Zinc	F81058-2	4
13	Cylinder, CJ-S170-16-40/25/152 Hydraulic	088681	2
14	Pin, Cylinder Mount	086979-1	2
15	Washer, 28 Flat Zinc	F81061-1	8
16	Pin, 3/16x1.5 Cotter Zinc	F05012-23	4
17	Bolt, 1-8x3 1/4 Hex Head Grade 5	F05009-51	2
18	Nut, 1-14 Hex Jam Unplated	F05010-117	2
19	Fitting, 1/4NPTx1/4JIC Male	P09143	4

9.14 Power Toe Roller

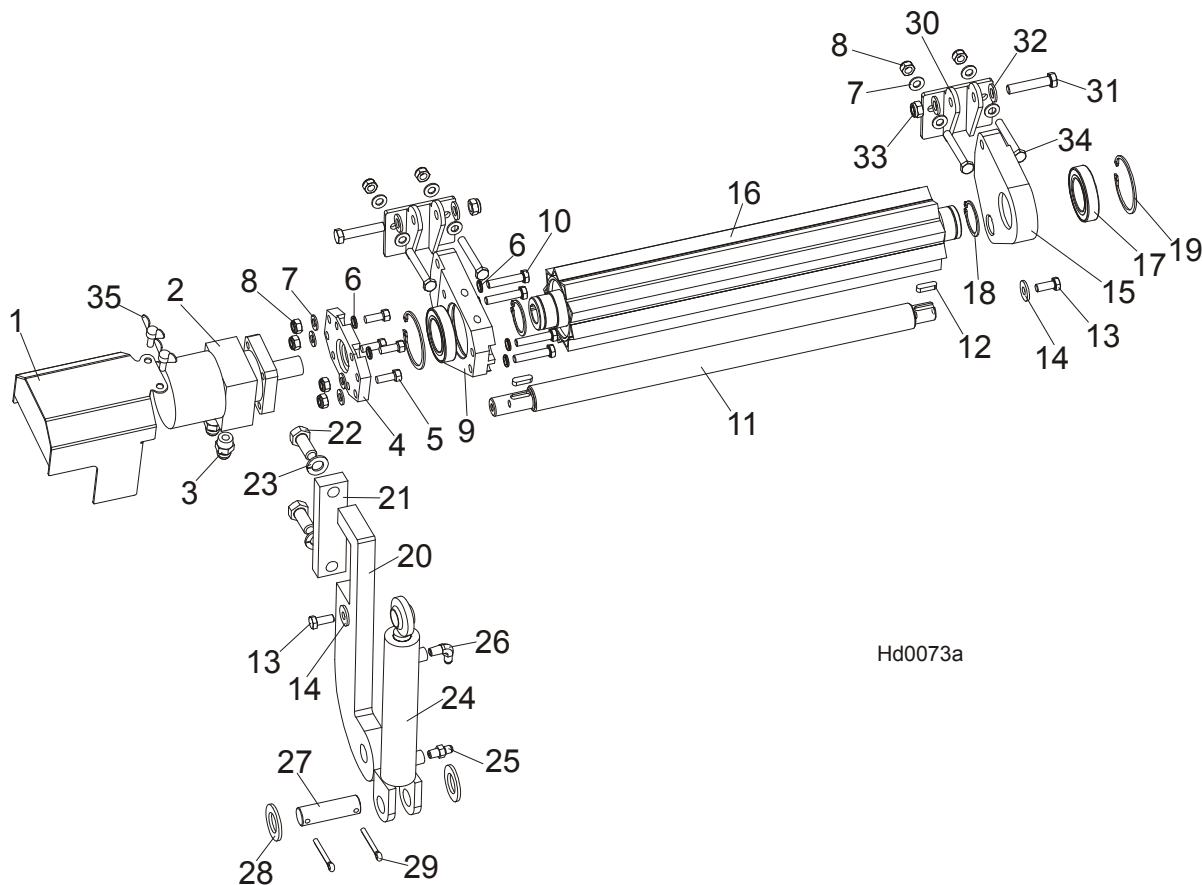

REF.	DESCRIPTION (◆ Indicates Parts Available In Assemblies Only)	PART#	QTY.
	POWER ROLLER	096040	1
1	Cover, Hydraulic Motor	096037-1	1
2	Motor, MG06-13-13AAAB Hyd	P21506	1
3	Fitting, 1/2-14NPT/ 7/16-20UNF	096919	2
4	Plate, Hydraulic Motor Mount	096030-1	1
5	Screw, 3/8-16x1, HHC	F05007-7	4
6	Washer, 10.2 Split Lock Zinc	F81055-2	4
7	Washer, 10,5 Flat Zinc	F81055-1	12
8	Nut, M10-8-B Nylon Hex Zinc Lock	F81033-1	8
9	Bracket, Side w/HydroMotor Connector	096029-1	1
10	Bolt, M10x50-8.8-Hex Head Full Thread Zinc	F81003-4	4
11	Rod	096034	1
12	Key, A8x7x28 Parallel	096035	2
13	Bolt, M10x25 8.8 Hex Head Full Thread Zinc	F81003-31	2
14	Washer, 10,5 Zinc Flat Special	F81055-6	2
15	Bracket	096031-1	1
16	Roller, Pivot - Wldmt	096028-1	1
17	Bearing, 6009.2RSR	096025	2
18	Ring, Z 45 Spring Retaining	F81090-32	2
19	Ring, W 75 Spring Retaining	F81090-41	2
20	Plate, Toe Board Cylinder Mount	087729-1	1

21	Plate, Hydraulic Toe Board Mount	090086-1	1	
22	Bolt, M16x40-8.8 Hex Head Full Thread Zinc	F81006-13	2	
23	Washer, 16,3 Split Lock Zinc	F81058-2	2	
	Cylinder, Hydraulic Toe Boards	085937	1	
24	Cylinder, CJ-S170-16-40/25/152 Hydraulic	088681	1	
25	Fitting, C5205x4x4 Male	P09143	1	
26	Fitting, 1/4NPTx1/4JIC Male Elbow	P09142	1	
27	Pin, Hydraulic Cylinder Zinc	086979-1	1	
28	Washer, 28 Flat Zinc	F81061-1	2	
29	Pin, S-Zn 6,3x45	F81045-2	2	
30	Bracket, Toe Board Roller Mount	087903-1	2	
31	Bolt, M12x60-8.8 Hex Head Zinc	F81004-5	2	
32	Washer, 13 Zinc Flat	F81056-1	4	
33	Nut, M12-8 Hex Nylon Zinc Lock	F81034-2	2	
34	Bolt, M10x75-8.8-Hex Head Zinc	F81003-15	4	
35	Stud, M6x16 Wing	F81001-16	2	