

Wood-Mizer[®] Sawmill

Parts Manual

LT70S AH
LT70M AH

rev. B2.01
rev. B2.01



Safety is our #1 concern! Read and understand all safety information and instructions before operating, setting up or maintaining this machine.

May 2002

Form #1052

Table of Contents

Section-Page

SECTION 1	GENERAL INFORMATION	1-1
1.1	How To Use The Parts List	1-1
1.2	Sample Assembly	1-1
SECTION 2	BLADE GUIDE ROLLERS & ARM	2-1
2.1	Blade Guide Assembly, Idle Side	2-1
2.2	Blade Guide Assembly, Drive Side	2-3
2.3	Blade Guide Arm Drive Assembly.....	2-5
SECTION 3	BLADE WHEELS & TENSIONER	3-1
3.1	Blade Drive Assembly.....	3-1
3.2	Idle Blade Wheel Assembly	3-3
3.3	Hydraulic Blade Tensioner Assembly.....	3-5
3.4	Sawdust Flow Guide.....	3-7
SECTION 4	SAW HEAD	4-1
4.1	Middle Throat Screw	4-1
4.2	Drive Belt Tensioner	4-2
4.3	Board Return Assembly (optional).....	4-3
4.4	Water Lube Assembly	4-5
4.5	Saw Head Decals.....	4-6
4.6	Blade Housing Covers.....	4-7
4.7	Sawdust Chute	4-8
SECTION 5	CONTROL BOXES	5-1
5.1	Control Assembly, LT70 AH.....	5-1
5.2	Drum Switches	5-3
5.3	Circuit Breakers.....	5-4
5.4	Front Panel Assembly & Harnesses	5-5
5.5	Solenoids	5-6
SECTION 6	UP/DOWN SYSTEM	6-1
6.1	Up/Down Rollers & Covers	6-1
6.2	Blade Height Scale	6-3
6.3	Up/Down Chain & Sprockets.....	6-5
6.4	Up/Down Drive Assembly	6-7
SECTION 7	FEED SYSTEM & TRACK ROLLERS	7-1
7.1	Upper Track Rollers And Wipers.....	7-1
7.2	Power Feed Assembly	7-3
7.3	Feed Chain/Stop, LT70 S/M	7-4
7.4	Lower Track Rollers.....	7-6

Table of Contents

Section-Page

SECTION 8	BED FRAME ASSEMBLY	8-1
8.1	Bed Rail Assembly, Front And Rear	8-1
8.2	Bed Rail Assembly, Front Middle	8-2
8.3	Bed Rail Assembly, Rear Middle	8-3
8.4	Clamp Mount Assembly, Front (A/DH5/7).....	8-4
8.5	Clamp Mount Assembly, Rear (A/DH5/7).....	8-6
8.6	Leg, Stationary	8-8
8.7	Board Return Table Assembly	8-10
8.8	Pivot Bed Rail Assembly.....	8-12
8.9	Log Side Support Assembly (Manual)	8-14
8.10	Tie Down Chain Assembly	8-16
8.11	LT70 S/M Saw Head Rest Pin Assembly.....	8-17
8.12	Bed Frame Decals	8-19
SECTION 9	HYDRAULIC SYSTEM	9-1
9.1	Hydraulic Hoses	9-1
9.2	Hydraulic Control Box, LT70 Series AH3.....	9-3
9.3	Hydraulic Control Box, LT70 Series AH5/7.....	9-5
9.4	Hydraulic Power Supply Strip.....	9-8
9.5	Hydraulic Log Loader	9-10
9.6	Hydraulic Log Turner	9-12
9.7	Hydraulic Log Side Supports (S/M Type Frame)	9-14
9.8	Hydraulic Log Clamp, Right	9-16
9.9	Hydraulic Log Clamp	9-18
9.10	Hydraulic Toe Board.....	9-20

SECTION 1 GENERAL INFORMATION

1.1 How To Use The Parts List

- Use the index above to locate the assembly that contains the part you need.
- Go to the appropriate section and locate the part in the illustration.
- Use the number pointing to the part to locate the correct part number and description in the table.
- Parts shown indented under another part are included with that part.
- Parts marked with a diamond (◆) are only available in the assembly listed above the part.

See the sample table below. Sample Part #A01111 includes part F02222-2 and subassembly A03333. Subassembly A03333 includes part S04444-4 and subassembly K05555. The diamond (◆) indicates that S04444-4 is not available except in subassembly A03333. Subassembly K05555 includes parts M06666 and F07777-77. The diamond (◆) indicates M06666 is not available except in subassembly K05555.

1.2 Sample Assembly				
REF	DESCRIPTION (◆ Indicates Parts Available In Assemblies Only)	PART #	QTY.	
	Sample Assembly, Complete (Includes All Indented Parts Below)	A01111	1	
1	Sample Part	F02222-22	1	
	Sample Subassembly (Includes All Indented Parts Below)	A03333	1	
2	Sample Part (◆ Indicates Part Is Only Available With A03333)	S04444-4	1	◆
	Sample Subassembly (Includes All Indented Parts Below)	K05555	1	
3	Sample Part (◆ Indicates Part Is Only Available With K05555)	M06666	2	◆
4	Sample Part	F07777-77	1	

To Order Parts:

- From Europe call our European Headquarters and Manufacturing Facility in Kolo, Poland at **+48-63-2626000**. From the continental U.S., call our toll-free Parts hotline at **1-800-448-7881**. Have your customer number, vehicle identification number, and part numbers ready when you call.
- From other international locations, contact the Wood-Mizer distributor in your area for parts.

SECTION 2 BLADE GUIDE ROLLERS & ARM

2.1 Blade Guide Assembly, Idle Side

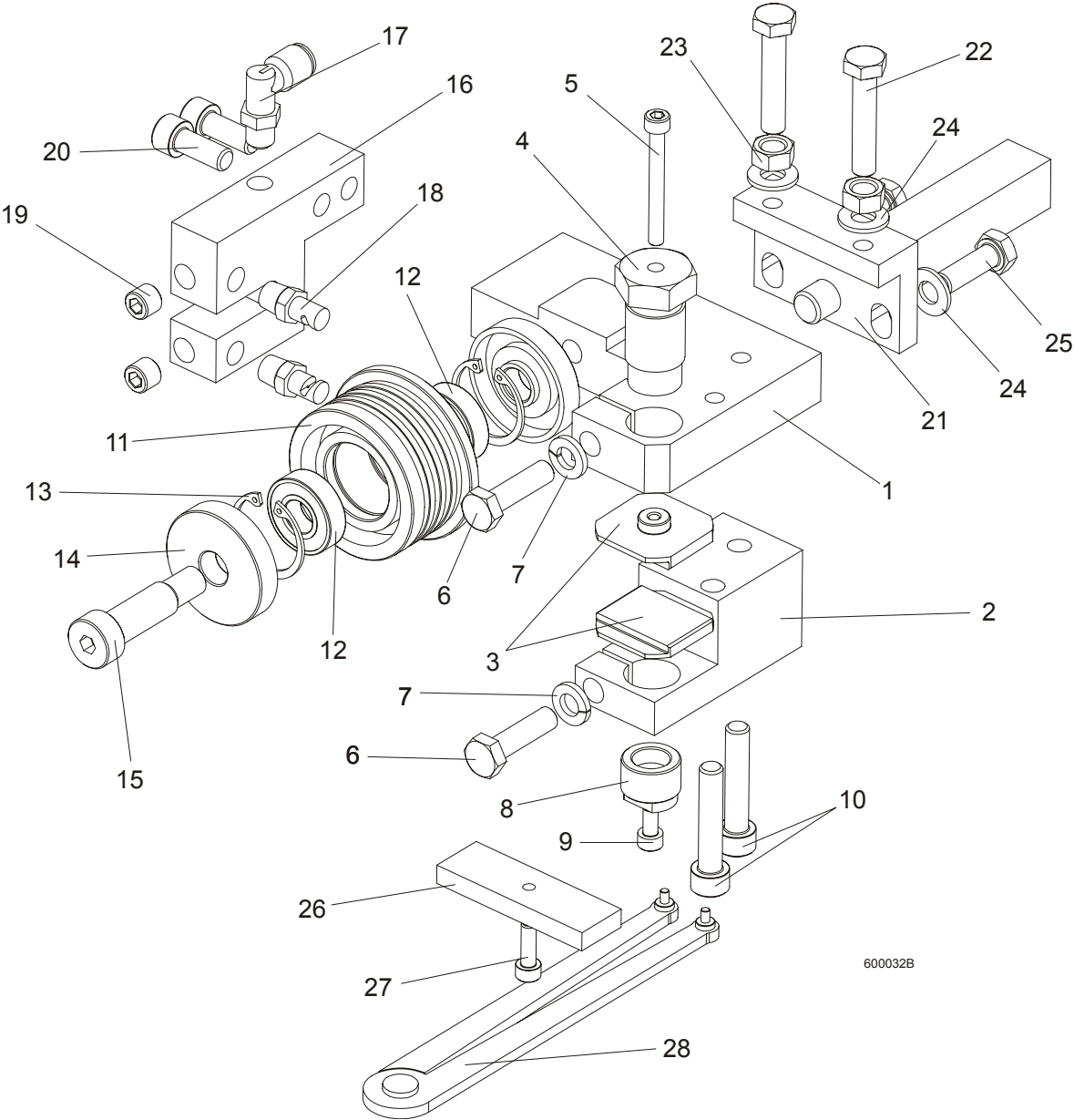

600032B

2 BLADE GUIDE ROLLERS & ARM

Blade Guide Assembly, Idle Side

REF	DESCRIPTION (u Indicates Parts Available In Assemblies Only)	PART#	QTY.	
	BLADE GUIDE ASSEMBLY, IDLE SIDE	090943	1	
	BLADE GUIDE ASSEMBLY, IDLE SIDE, EXTENDED (for optional use with 1 1/2" blades)	092997	1	
1	Block, Blade Guide Mount Zinc-plated	090947-1	1	
2	Block, Lower Ceramic Pad Mount Zinc-plated	090948-1	1	
3	Block, Blade Guide Zinc	093430-1	2	
4	Bolt, Upper Pad Adjustment Zinc-plated	089515-1	1	
5	Screw, M5x45 DIN912 A2-70 Hex Socket Head Cap Stainless Steel	F81000-24	1	
6	Bolt, M8x30 DIN933 A2-70 Stainless Steel	F81002-27	2	
7	Washer, 8.2 Split Lock Zinc	F81054-4	2	
8	Screw, Lower Pad Adjuster Zinc-plated	090945-1	1	
9	Screw, M5x10 DIN912 A2-70 Hex Socket Head Cap Stainless Steel	F81000-23	1	
10	Screw, M8x40-8.8 Hex Socket Head Cap Zinc	F81002-29	2	
	Roller, Blade Guide Narrow W/Bearing	088261	1	
	Roller, Blade Guide W/Bearing, Extended	092939	1	
11	Roller, Blade Guide Narrow	087889	1	
12	Bearing, 6001 2RSR NACHI	087893	2	
13	Ring, W28 Inside Retaining	F81090-9	2	
14	Washer, Blade Guide Roller Spacer Zinc-plated	087891-1	2	
15	Screw, 12/M10x30 12.9 ISO 7379 Socket Head Shoulder	F81003-70	1	
	Screw, 12/M10x35 12.9 ISO 7379 Socket Head Shoulder, (used with the Extended Roller only)	F81003-48	1	
16	Block, Nozzle Mounting Zinc-plated	090487-1	1	
17	Fitting, 90° Elbow 1/8NPT-1/4 Tube Swivel	P09736	1	
18	Nozzle, Blade Lube Spray	033479	2	
19	Plug, M10x1 DIN 906 BN40 "BOSSARD"	F81015-3	2	
20	Screw, M8x20-8.8 Hex Socket Head Cap Zinc	F81002-30	2	
21	Pivot Weldment, Blade Guide Zinc-plated	089509-1	1	
22	Bolt, M8x40 DIN933 A2-70 Stainless Steel	F81002-28	2	
23	Nut, M8 DIN934 A2-70 Stainless Steel	F81032-7	2	
24	Washer, 8.4 Zinc Flat	F81054-1	4	
25	Bolt, M8x25 DIN933 A2-70 Stainless Steel	F81002-26	2	
	Block, Blade Guide Alignment	090951	1	
26	Block, Blade Guide Alignment Zinc-plated	090805-1	1	
27	Screw, M5x16-8.8 Hex Socket Head Cap Zinc	F81000-25	1	
28	Tool, 62860-3 (PERSCHMAN) Lower Pad Adjustment	090949	1	

2.2 Blade Guide Assembly, Drive Side

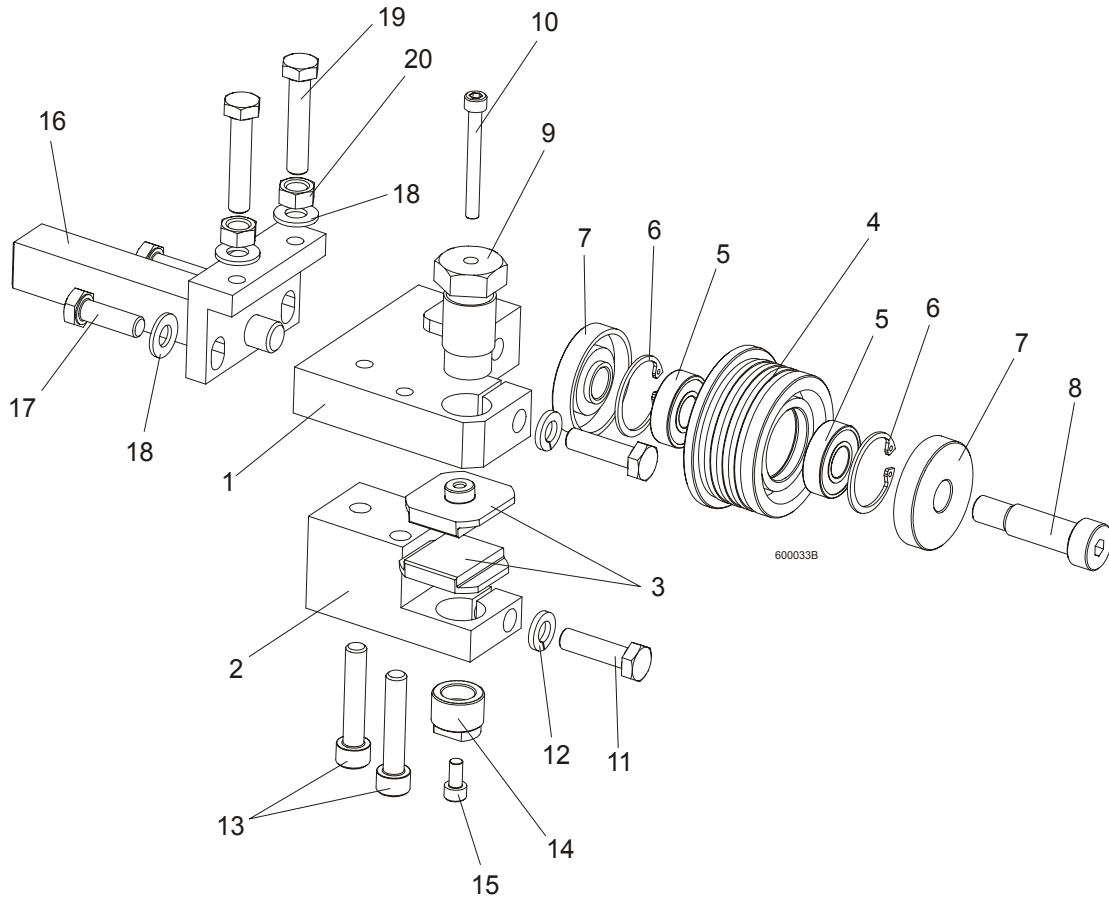

REF	DESCRIPTION (u Indicates Parts Available In Assemblies Only)	PART #	QTY.	
	BLADE GUIDE ASSEMBLY, DRIVE SIDE	090942	1	
	BLADE GUIDE ASSEMBLY, DRIVE SIDE, EXTENDED (for optional use with 1 1/2" blades)	092998	1	
1	Block, Blade Guide Mount Zinc-plated	090944-1	1	
2	Block, Lower Ceramic Pad Mount Zinc-plated	090946-1	1	
3	Block, Blade Guide Zinc	093430-1	2	
	Roller, Blade Guide Narrow W/Bearing	088261	1	
	Roller, Blade Guide W/Bearing, Extended	092939	1	
4	Roller, Blade Guide Narrow	087889	1	
5	Bearing, 6001 2RSR NACHI	087893	2	◆
6	Ring, W28 Inside Retaining	F81090-9	2	
7	Washer, Blade Guide Roller Spacer Zinc-plated	087891	2	
8	Screw, 12/M10x30 12.9 ISO 7379 Socket Head Shoulder	F81003-70	1	
	Screw, 12/M10x35 12.9 ISO 7379 Socket Head Shoulder (used with the Extended Roller only)	F81003-48	1	

2**BLADE GUIDE ROLLERS & ARM***Blade Guide Assembly, Drive Side*

9	Bolt, Upper Pad Adjustment	089515	1	
10	Screw, M5x45 DIN912 A2-70 Hex Socket Head Cap Stainless Steel	F81000-24	1	
11	Bolt, M8x30 DIN933 A2-70 Stainless Steel	F81002-27	2	
12	Washer, 8.2 Split Lock Zinc	F81054-4	2	
13	Screw, M8x40-8.8 Hex Socket Head Cap Zinc	F81002-29	2	
14	Screw, Lower Pad Adjustment Zinc-plated	090945-1	1	
15	Screw, M5x10 DIN912 A2-70 Hex Socket Head Cap Stainless Steel	F81000-23	1	
16	Pivot Weldment, Blade Guide Zinc-plated	089509-1	1	
17	Bolt, M8x25 DIN933 A2-70 Stainless Steel	F81002-26	2	
18	Washer, 8.4 Zinc Flat	F81054-1	4	
19	Bolt, M8x40 DIN933 A2-70 Stainless Steel	F81002-28	2	
20	Nut, M8 DIN934 A2-70 Stainless Steel	F81032-7	2	

2.3 Blade Guide Arm Drive Assembly

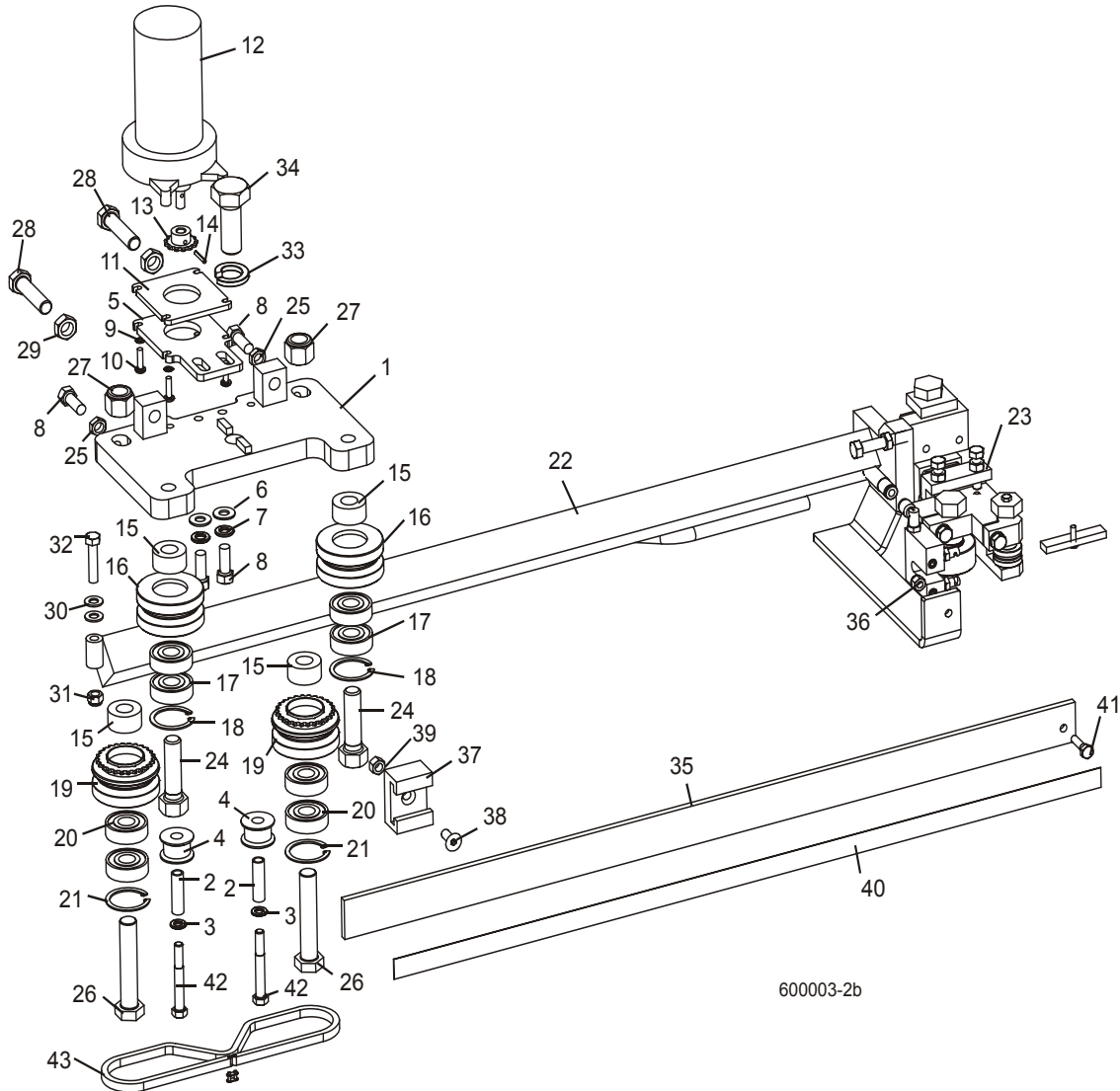

REF	DESCRIPTION (u Indicates Parts Available In Assemblies Only)	PART#	QTY.
	BLADE GUIDE ARM ASSEMBLY	090950	1
1	Plate Weldment, Blade Guide Arm Zinc-plated	090800-1	1
2	Bushing, 0.322 x 0.44 x 1 1/2" Spacer	S09996	2
3	Washer, 5/16" Split Lock Zinc	F05011-13	2
4	Roller, Chain Guide	090801	2
5	Plate, Blade Guide Motor Mount Ptd	090803-1	1
6	Washer, 10.5 Zinc Flat	F81055-1	2
7	Washer, 3/8" Zinc Flat	F05011-4	2
8	Bolt, M10 x 25 8.8 Hex Head Full Thread	F81003-31	4

2 BLADE GUIDE ROLLERS & ARM

Blade Guide Arm Drive Assembly

9	Washer, 5.3 Zinc Flat	F81052-1	4	
10	Screw, #10-32 x 3/4 CrS1 Phillips Head	F05004-38	4	
11	Plate, Spacer Ptd	090802-1	1	
12	Motor, 53:1 Gear ASA Blade Guide Arm	P09698-1	1	
13	Sprocket, 25B13 x .3130	P09970	1	
14	Pin, 3 x 14 Zinc Roll	F81044-4	1	
15	Spacer, Drive Roller Zinc-plated	090804-1	4	
	ROLLER ASSEMBLY, BLADE GUIDE ARM IDLER	042543	2	
16	Housing, 2 1/2" V-Groove	042536	1	
17	Bearing, 6203-2NSL 5/8	P06030-1	2	
18	Ring, 1.575" ID 5002-156 Retaining	F04254-8	1	
	ROLLER ASSEMBLY, BLADE GUIDE ARM DRIVE	042542	2	
19	Housing, 2 1/2" V-Groove W/Sprocket	042541	1	
20	Bearing, 6203-2NSL 5/8	P06030-1	2	
21	Ring, 1.575" ID 5002-156 Retaining	F04254-8	1	
22	Arm Weldment, Blade Guide Zinc-plated	090479-1	1	
23	Blade Guide Parts (See Section 2.1)			
24	Bolt, 5/8-18 x 2 1/4 Hex Head Grade 5	F05009-80	2	
25	Nut, M10-04-W Zinc Hex Thin	F81033-6	2	
26	Bolt, 5/8-18 x 3 1/4 Hex Head Grade 5	F05009-80	2	
27	Nut, 5/8-18 Hex Nylon Lock	F05010-71	2	
28	Screw, M12 x 1.25 x 60-33H Zinc Hex Set W/Full Dog Point	F81004-52	2	
29	Nut, M12 x 1.25 8.8 Zinc Hex Thin	F81034-5	2	
30	Washer, 8.4 Zinc Flat	F81054-1	1	
31	Nut, M8-8-B Hex Nylon Zinc Lock	F81032-2	1	
32	Bolt, M8 x 40-8.8 Hex Head Full Thread Zinc	F81002-15	1	
33	Washer, DIN 6319-21C Spherical	F81059-6	1	
34	Bolt, M20 x 1.5 x 50-8.8-B Hex Head Full Thread Zinc	F81007-2	1	
35	Guard, Blade	088306	1	
36	Nut, M6-8-B Hex Nylon Zinc LOck	F81031-2	1	
37	Guide, Blade Guard	088305	1	
38	Screw, M8 x 25 Cross Recessed Countersunk Head Zinc	F81002-51	1	
39	Nut, M8-8-B Hex Nylon Zinc Lock	F81032-2	1	
40	Decal, Warning	015849	1	
41	Bolt, M6 x 20-8.8 Hex Head Full Thread Zinc	F81001-2	2	
42	Screw, 12/M10 x 20 12.9 ISO7379(BOSSARD) Socket Head Shoulder	F81003-68	2	
43	Chain, #25 x 92 PITCHES B/G	093805	1	

SECTION 3 BLADE WHEELS & TENSIONER

3.1 Blade Drive Assembly

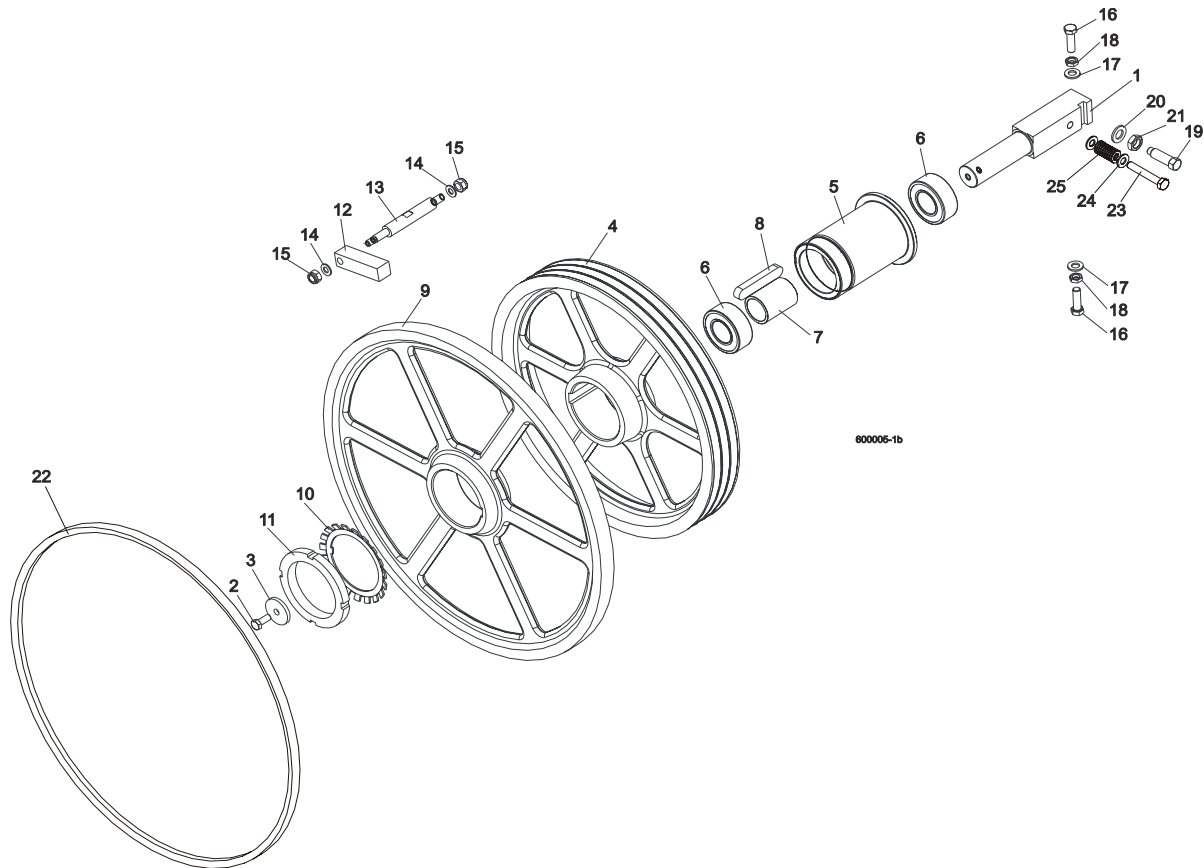

REF	DESCRIPTION (◆ Indicates Parts Available In Assemblies Only)	PART #	QTY.
1	SHAFT, BLADE DRIVE WHEEL	088475	1
2	BOLT, M10x25 8.8 HEX HEAD FULL THREAD	F81003-31	1
3	WASHER, BLADE DRIVE WHEEL	088956-1	1
	PULLEY ASSEMBLY, BLADE DRIVE (AC)	089493	1
4	Pulley, 3-Groove	088446-1	1
5	Bushing, Blade Drive Wheel	088476	1
6	Bearing, 3208.2rsr.tvh (FAG) Rolling	088449	2
7	Spacer, Drive Bearing	088478	1
8	Key, A20x12x100 Parallel	088477	1
9	WHEEL, BLADE DRIVE	090811	1
10	WASHER, MB21 (FAG) LOCK	088451	1
11	NUT, KM21(M105X2) (FAG) LOCK	088450	1
12	BAR, WHEEL SCRAPER	088781	1
13	SHAFT, WHEEL SCRAPER	088780-1	1

3 Blade Wheels & Tensioner

Blade Drive Assembly

14	WASHER, 10.5 ZINC FLAT	F81055-1	2	
15	NUT, M12-8 HEX NYLON ZINC LOCK	F81034-2	2	
16	BOLT, M12X1.25X40 HEX HEAD	F81004-42	3	
17	WASHER, 13 FLAT ZINC	F81056-1	3	
18	NUT, M12X1.25 8.8 THIN ZINC	F81034-5	3	
19	SCREW, M16X1.5X50-33H HEX HEAD FULL DOG POINT SET ZINC	F81006-14	1	
20	WASHER, 17 ZINC FLAT	F81058-1	1	
21	NUT, M16x1.5-08-B ZINC THIN	F81036-6	1	
22	BELT, BLADE WHEEL B72.5	017922	1	
23	BOLT M10X65	F81003-67	1	
24	WASHER, 10.5 ZINC FLAT	F81055-1	2	
25	SPRING19X38	034430	1	

3.2 Idle Blade Wheel Assembly

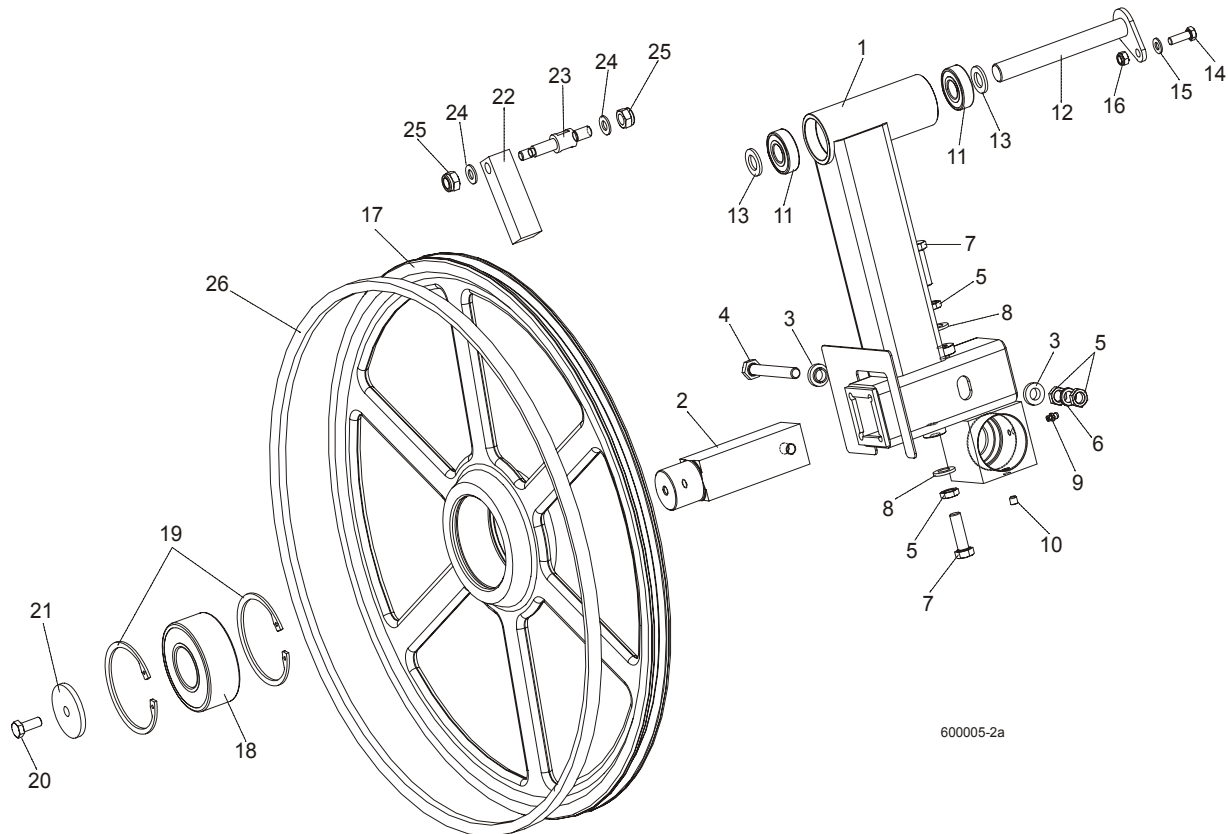

REF	DESCRIPTION (◆ Indicates Parts Available In Assemblies Only)	PART #	QTY.
	TUBE WELDMENT, LT60 IDLE SIDE BLADE WHEEL COMPLETE	088762	1
1	Tube Weldment, LT60 Idle Blade Wheel	088434-1	1
2	Shaft, Idle Blade Wheel	088474	1
3	Washer, Zinc Special	086769-1	2
4	Bolt, M12x1.25x100-8.8 Hex Head Zinc	F81004-41	1
5	Nut, M12x1.25 8.8 Hex ZincThin	F81034-5	4
6	Washer, Z12.2 Split Zinc Lock	F81056-2	1
7	Bolt, M12x1.25x40 Hex Head	F81004-42	2
8	Washer, 13 Zinc Flat	F81056-1	2
9	Fitting, M6 Straight Grease	086280	1
10	Screw, M8x8-33H Hex Socket Set Flat Point Zinc	F81014-1	1
11	Bearing, 6204 2RS-CX Rolling	088447	2
12	PIN WELDMENT, PIVOT	088759-1	1
13	WASHER, 17 ZINC FLAT	F81058-1	2
14	BOLT, M8X25-8.8-B HEX HEAD FULL THREAD ZINC	F81002-5	1
15	WASHER, 8.4 ZINC FLAT	F81054-1	1
16	NUT, M8-8-B HEX NYLON ZINC LOCK	F81032-2	1

3 Blade Wheels & Tensioner

Idle Blade Wheel Assembly

	WHEEL ASSEMBLY, IDLE SIDE	090952	1	
17	Wheel, Blade Idle Side	090810-1	1	
18	Bearing, 3309B.2RSR.TVH-P66 FAG	086428	1	
19	Ring, W100 Spring Retaining	F81090-10	2	
20	BOLT, M10X25 8.8 HEX HEAD FULL THREAD	F81003-31	1	
21	WASHER, IDLE BLADE WHEEL RETAINING	088957-1	1	
22	SCRAPER, IDLE BLADE WHEEL	088781	1	
23	SHAFT, SHORT ZINC WHEEL SCRAPER	088779-1	1	
24	WASHER, 10.5 ZINC FLAT	F81055-1	2	
25	NUT, M12-8 HEX NYLON ZINC LOCK	F81034-2	2	
26	BELT, BLADE WHEEL B72.5	017922	1	

3.3 Hydraulic Blade Tensioner Assembly

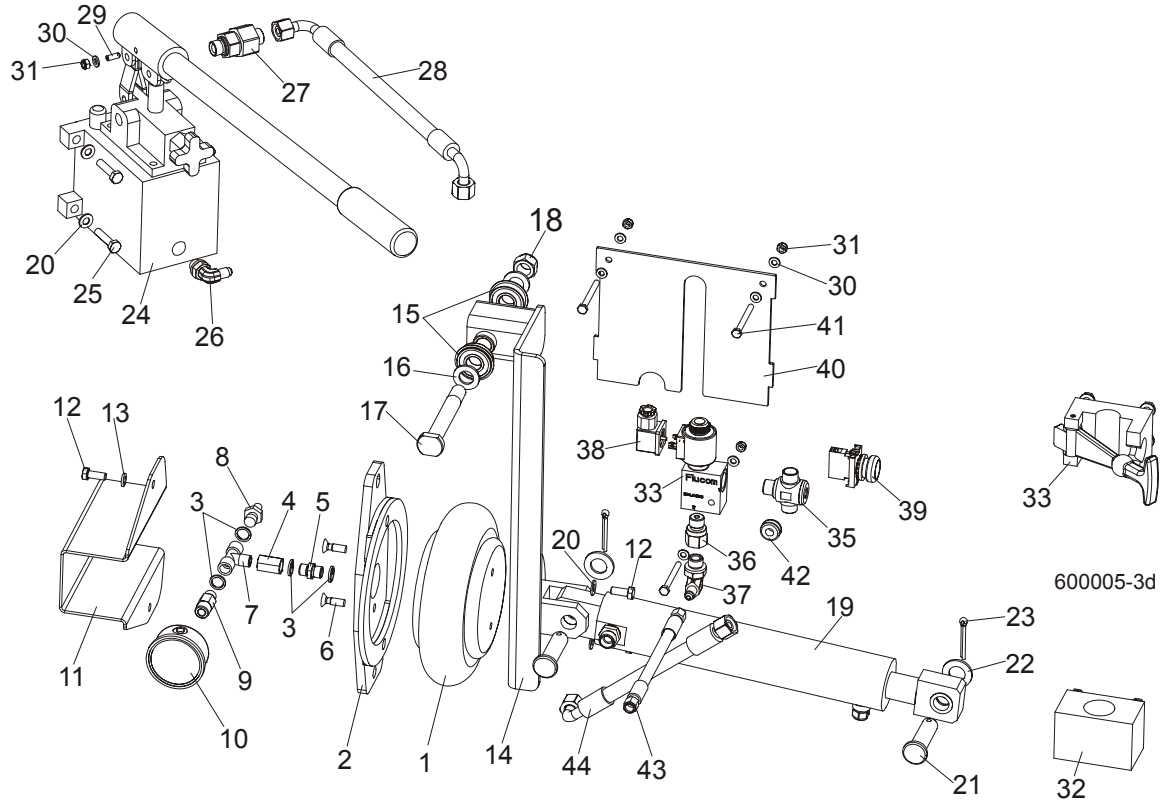

REF	DESCRIPTION (◆ Indicates Parts Available In Assemblies Only)	PART #	QTY.
	HYDRAULIC BLADE TENSIONER, COMPLETE	092775	1
1	Bag, POJ 192 308 100 0 Air	088576	1
2	Bracket, Air Bag Mount	088798-1	1
3	Seal, G1/4 866-014-000-0	090809	4
4	Fitting, 1/4 Female Thread/1/4 Female Thread 893-302-000-4	090808	1
5	Nipple, 1/4 Thread/1/4 Thread 893-104-430-4	090807	1
6	Bolt, M8x25 Pan Head Zinc	F81002-51	2
7	Fitting, PO 2301 002 2 Tee Connector	088573	1
8	Fitting, 1/4" Thread 390 004 004 0 (REXROTH) Air Tank Valve	088575	1
9	Fitting, 1/8" Thread x 1/4" Thread	088571	1
10	Gauge, M63T-2,5/20G G 1/8 0-0,6 MPa/PSI Air Pressure	088568	1
11	Guard, Air Pressure Gauge	088924-1	1
12	Screw, M8x25 Cross Recessed Countersunk Head Zinc	F81002-4	4
13	Washer 8.2 Zinc Split	F81054-4	2
14	Arm, Air Cylinder Painted	092779-1	1
15	Bearing w/Snap Ring 6203-2RS	086395	2
16	Washer, M16, Flat Zinc	F81058-1	2
17	Pin, Idler Arm Mount	086404	1

18	Nut, M16, Hex, Nylon Zinc Lock	F81036-2	2	
19	Cylinder, Air Complete	092788	1	
20	Washer, 8.4 Zinc Flat	F81054-1	6	
21	Pin, PN-EN 22341-B-18x65x57-A2	F81049-4	2	
22	Washer, 19 Flat Zinc	F81060-1	2	
23	Pin, S-Zn 5x40 PN-M/82001	F81043-31	2	
24	Pump,PMS12/TNK1 Manual w/Tank 1l	092789	1	
25	Bolt, 8mm x 1.25x35mm HH Zinc	F81002-13	4	
26	Elbow, CA-204410-3	094562	1	
27	Valve, RHV12LREDA3C Check	094559	1	
28	Hose, DN12 w/fittings PN10AOL90 M18x1,5	094565	1	
29	Latch, GN615.3-M6-KN Ball Threaded	096874	1	
30	Washer, M6, Flat, Zinc	F81053-1	7	
31	Nut, M6, Hex, Nylon Lock Zinc	F81031-2	4	
32	Bracket, Tensioner Pump Handle Bottom	096951	1	
33	Bracket, Tensioner Pump Handle Upper	092800	1	
34	Valve, ECP 20/22B2	094564	1	
35	T-connection, HD-TH-12L-BE-06	094560	1	
36	Fitting, G 3/8 Throttle	096849	1	
37	Elbow, CA-204411-3	094563	1	
38	Connector, 300.11.00 Solenoid	094555	1	
39	Pushbutton, M22 momentary, flat green	094581	1	
40	Cover, Solenoid Painted	094569-1	1	
41	Bolt, M6x60mm Hex Head, Zinc	F81001-9	3	
42	Grommet, Rubber 3/8 ID	025248	1	
43	Hose, 1/4 w/fittings JIC 7/16-20	092806	1	
44	Hose, DN12 w/fittings PN10AOL90 i PN10AOL M1.5	096964	1	

3.4 Sawdust Flow Guide

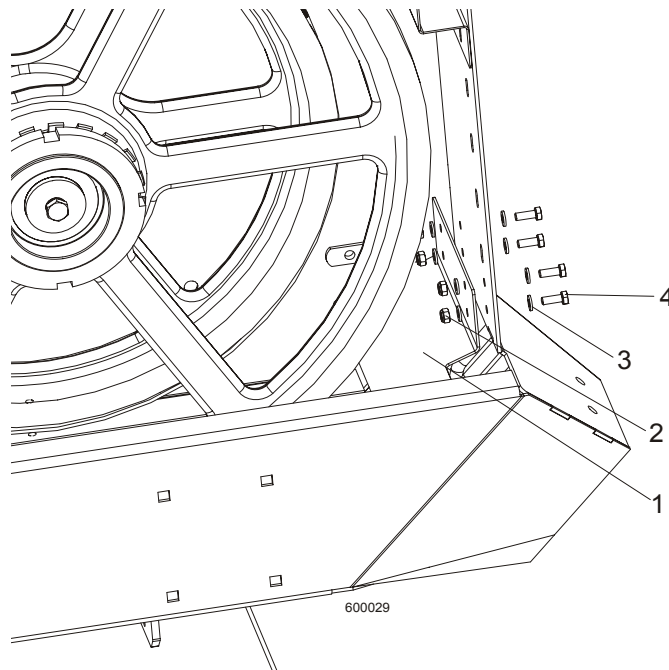

REF	DESCRIPTION (◆ Indicates Parts Available In Assemblies Only)	PART #	QTY.	
1	Guide, Sawdust Flow Painted	090506	1	
2	Nut, M6-8-B Hex Nylon Zinc Lock	F81031-2	4	
3	Washer 6.4 Zinc Flat	F81053-1	8	
4	Bolt, M6x16-8.8, Hex Head Full Thred, Zinc	F81001-32	4	

4 Saw Head
Middle Throat Screw

SECTION 4 SAW HEAD

4.1 Middle Throat Screw

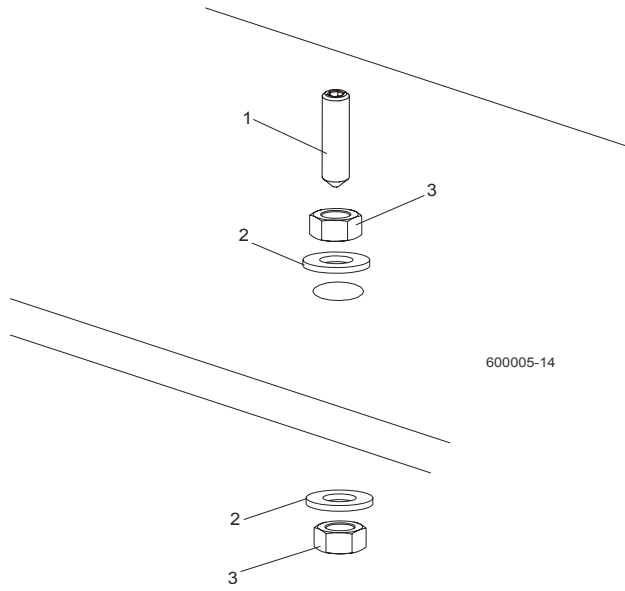

REF	DESCRIPTION (◆ Indicates Parts Available In Assemblies Only)	PART #	QTY.	
1	SCREW, M10X40-45H HEX SOCKET SET CONE POINT ZINC	F81003-61	1	
2	WASHER, 10.5 ZINC FLAT	F81055-1	2	
3	NUT, M10-8-B ZINC HEX	F81033-3	2	

4.2 Drive Belt Tensioner

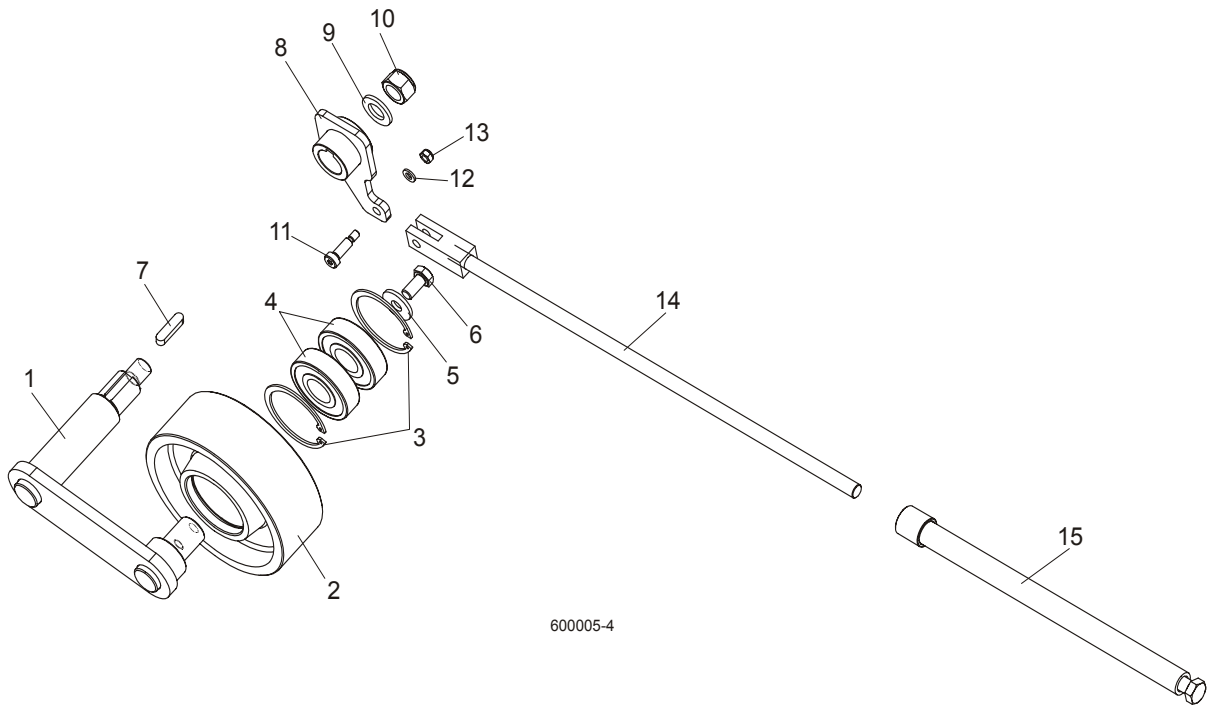

REF	DESCRIPTION (◆ Indicates Parts Available In Assemblies Only)	PART #	QTY.
	TENSIONER ASSEMBLY, DRIVE BELT	088786	1
1	Pivot Weldment, Drive Belt Tensioner	088810-1	1
2	Wheel, Belt Tension	088814	1
3	Ring, 62 mm Inside Spring Retaining	F81090-1	2
4	Bearing, 6305 2RS NSK	P08066	2
5	Washer, 11 Dia. Zinc Flat Special	088787-1	1
6	Bolt, M10x20-5.8 Hex Head Full Thread Zinc	F81003-1	1
7	Key, A8X7X32 Parallel	088564	1
8	Arm Weldment, Drive Belt Tensioner	088807-1	1
9	Washer, 17 Zinc Flat	F81058-1	1
10	Nut, M16-5.8 Zinc Hex	F81036-2	1
11	Bolt, 8/M6X20 12.9 ISO 7379 BOSSARD	F81001-25	1
12	Washer 6.4 Zinc Flat	F81053-1	1
13	Nut, M6-8-B Hex Nylon Zinc Lock	F81031-2	1
14	Rod Weldment, Threaded Zinc-Plated	088789-1	1
15	Tube Weldment, Threaded Zinc-Plated	088782-1	1

4 Saw Head

Board Return Assembly (optional)

4.3 Board Return Assembly (optional)

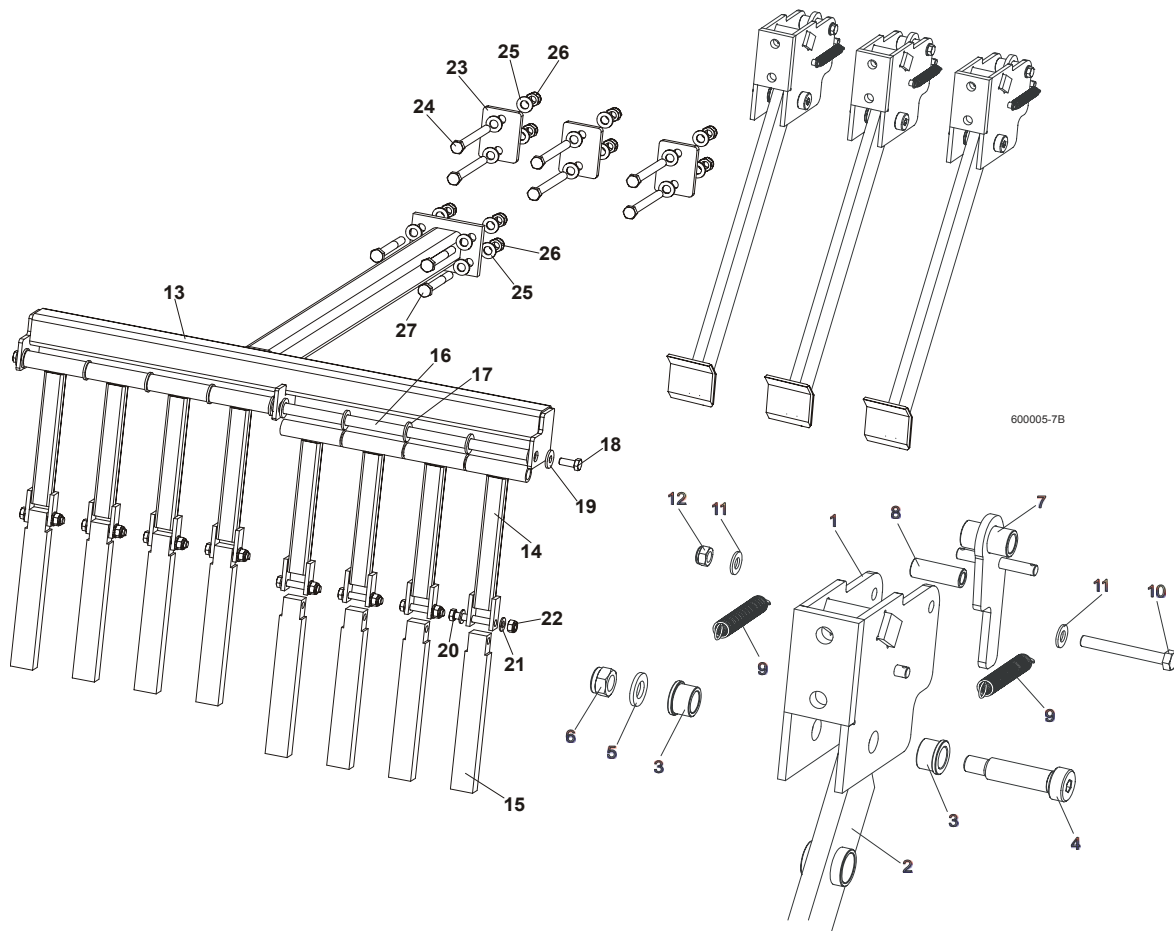

REF	DESCRIPTION (◆ Indicates Parts Available In Assemblies Only)	PART #	QTY.
	BOARD RETURN ASSEMBLY, LT70	092757	1
	Board Return Assembly	090120	3
1	Mount Weldment, Board Return Arm	090109-1	3
2	Arm, Board Return	090112-1	3
3	Bushing, Bronze	086676	6
4	Bolt, 16/M12x50-12.9 ISO7379-BOSSARD Socket Head	F81004-25	3
5	Washer, 13 Zinc Flat	F81056-1	3
6	Nut, M12-8 Hex Nylon Zinc Lock	F81034-2	6
7	Latch Weldment, Board Return Arm	090118-1	3
8	Spacer, Zinc	090115-1	3
9	Spring, 1/2 x 2 1/4 x 0,06 Extension	014817	6
10	Bolt, M8 x 65-5.8 Hex Head Zinc	F81002-3	3
11	Washer, 8.4 Zinc Flat	F81054-1	6

12	Nut, M8-8-B Hex Nylon Zinc Lock	F81032-2	3	
	Guide, Board Return	091076	1	
13	Guide Weldment, Board Return	091067-1	1	
14	Bar Weldment, Board Guide Upper	091070-1	8	
15	Bar, Board Guide Lower Aluminium	091071	8	
16	Rod, Board Return Guide	091074	1	
17	Washer, M16, Flat Zinc	F81058-1	10	
18	Bolt, M10x25 8.8, Hex Head, Full Thrd, Zinc	F81003-31	2	
19	Washer, 10,5 Fe/Zn5	F81055-6	2	
20	Bolt, M10x60 -8.8, Hex Head, Full Thrd, Zinc	F81003-10	8	
21	Washer, M10, Flat Zinc	F81055-1	16	
22	Nut, M10, Nylon Hex Zinc Lock	F81033-1	8	
23	Washer, Special	092756-1	3	
24	Bolt, M12x120, Hex Head, Full Thrd, Zinc	F81004-38	6	
25	Washer, 13 Zinc	F81056-1	20	
26	Nut, M12 Hex Nylon Zinc Lock	F81034-2	10	
27	Bolt, M12x100, Hex Head, Full Thrd, Zinc	F81004-3	4	

4 Saw Head

Water Lube Assembly

4.4 Water Lube Assembly

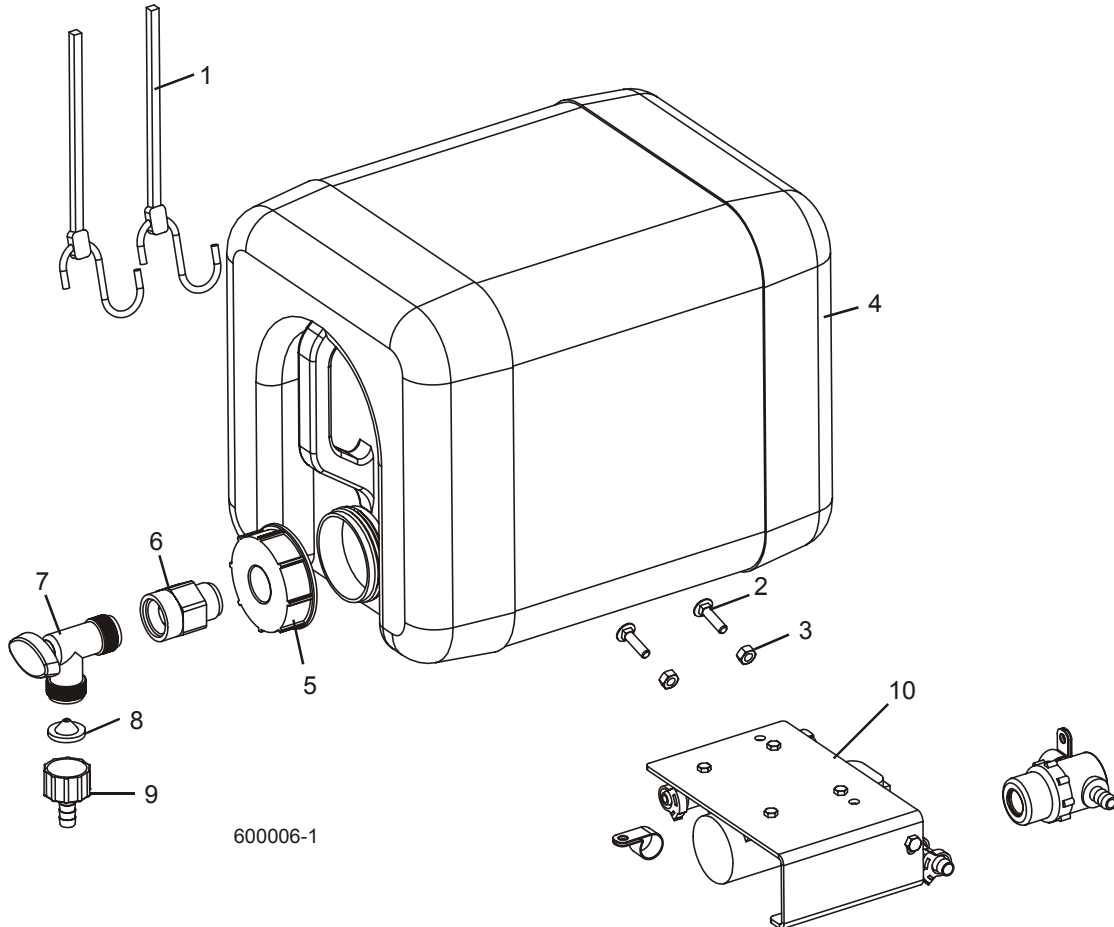

REF	DESCRIPTION (◆ Indicates Parts Available In Assemblies Only)	PART #	QTY.	
1	STRAP, 20" RUBBER	P11668	2	
2	BOLT, 1/4-20 X 1" CARRIAGE HEAD	F05005-34	2	
3	NUT, 1/4-20 HEX LOCK	F05010-21	2	
4	BOTTLE, 5-GALLON WATER LUBE	014637	1	◆
5	CAP, WATER LUBE BOTTLE BUTTRESS THREAD	016123	1	
6	FITTING, 3/4FPT X 3/4MPT	014636	1	
7	FITTING, WATER LUBE SHUTOFF VALVE	014100	1	
8	FILTER, WATER LUBE	016086	1	
9	FITTING, 5/8" NPT TO 3/8" HOSE BARB	014113	1	
10	LUBEMIZER PARTS/HOSES (SEE LUBEMIZER OPTION MANUAL)			

4.5 Saw Head Decals

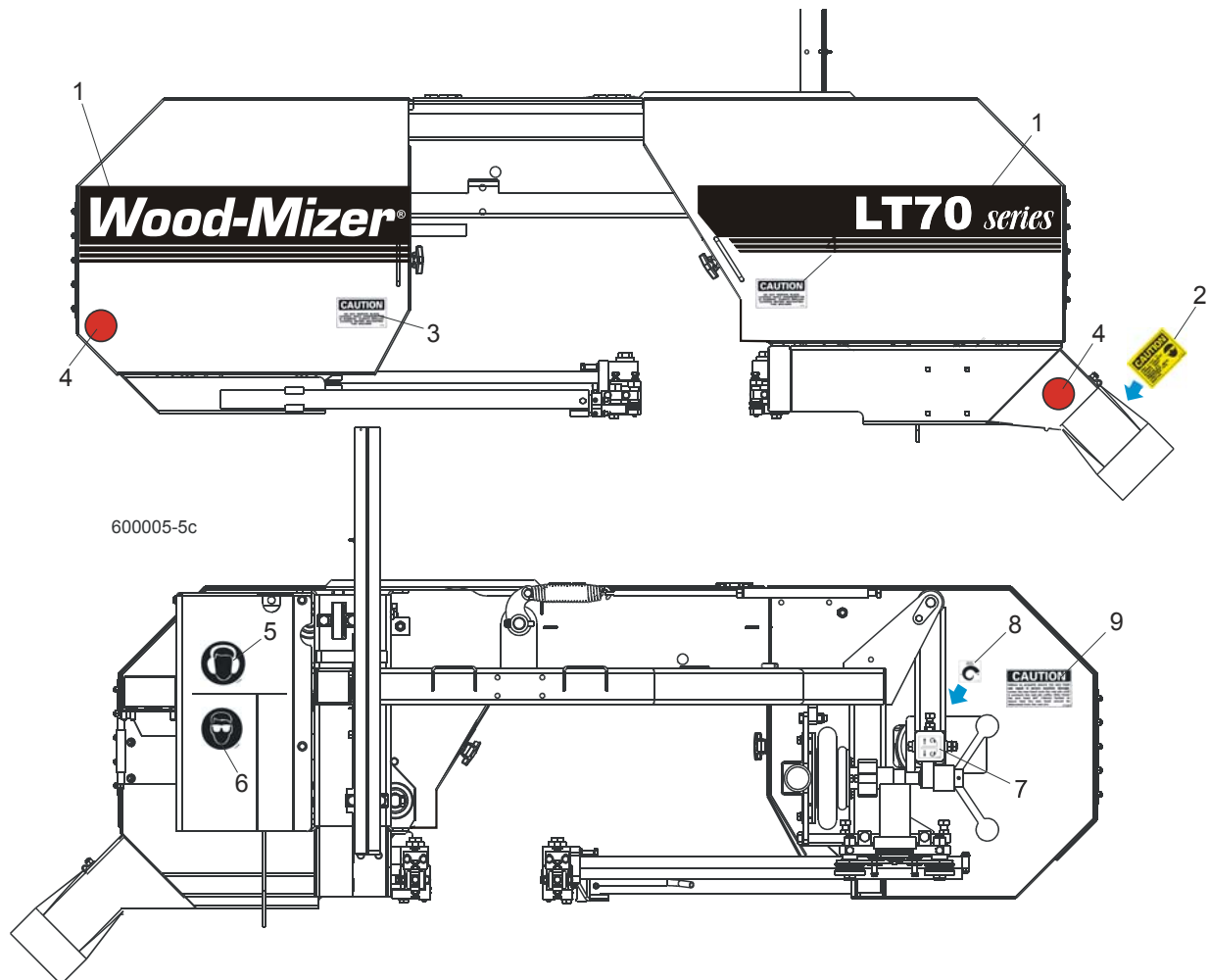

REF	DESCRIPTION (◆ Indicates Parts Available In Assemblies Only)	PART #	QTY.
1	DECAL, LT80 LOGO	087932	1
1	DECAL, LT70 LOGO	092764	1
2	DECAL, SAWDUST CHUTE CAUTION	P11754	1
3	DECAL, BLADE COVERS DANGER	S20039	2
4	REFLECTOR, 2" RED	P07452	2
5	DECAL, EYE WARNING	S12004G	1
6	DECAL, EAR WARNING	S12005G	1
7	DECAL, BLADE ALIGNMENT	P11789	1
8	DECAL, BLADE TENSION SCREW	P11790	1
9	DECAL, SAW HEAD REST CAUTION	S12581	1

4 Saw Head Blade Housing Covers

4.6 Blade Housing Covers

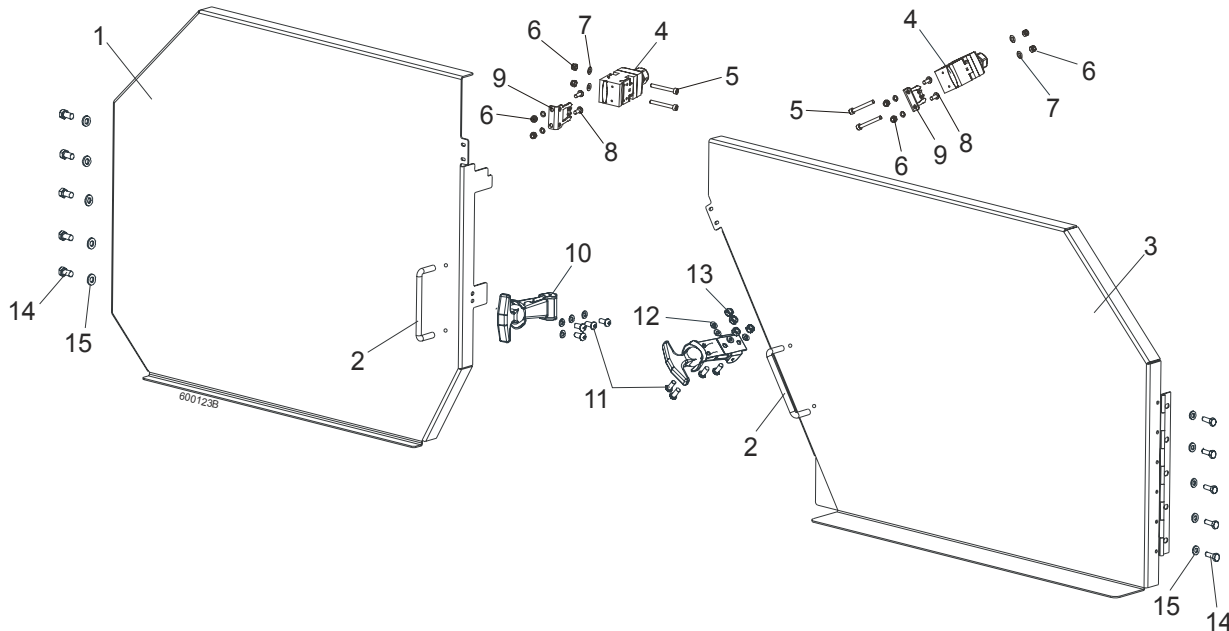

REF	DESCRIPTION (◆ Indicates Parts Available In Assemblies Only)	PART #	QTY.
	COVER ASSEMBLY, IDLE SIDE BLADE HOUSING	088920	1
1	Cover Assembly, Idle Side Blade Housing, Ptd	088915-1	1
2	Handle, Blade Housing Cover	P08065	1
	COVER ASSEMBLY, DRIVE SIDE BLADE HOUSING	088921	1
3	Cover Assembly, Drive Side Blade Housing, Ptd	088917-1	1
2	Handle, Blade Housing Cover	P08065	1
4	LIMIT SWITCH, HONEYWELL GKMB 23W2	086681	2
5	BOLT, M4 X 35-8.8 SOCKET HEAD	F81011-34	4
6	NUT, M4-B HEX NYLON ZIN	F81028-2	8
7	WASHER 4,3 ZINC, FLAT	F81051-2	8
8	SCREW, M4 X 12-5.8	F81011-41	4
9	KEY, AZ17/170-B5 SAFETY SWITCH	094422	4
10	LATCH, FLEXIBLE DRAW	014829	2
11	BOLT, M5X12-5.8	F81000-5	8
12	WASHER 5,3 ZINC FLAT	F81052-1	8
13	NUT M5-8 DIN 985 ZINC	F81030-2	8
14	BOLT, M6X16 8.8 HEX HEAD FULL THREAD ZINC	F81001-15	10
15	WASHER 6.4 ZINC FLAT	F81053-1	10

4.7 Sawdust Chute

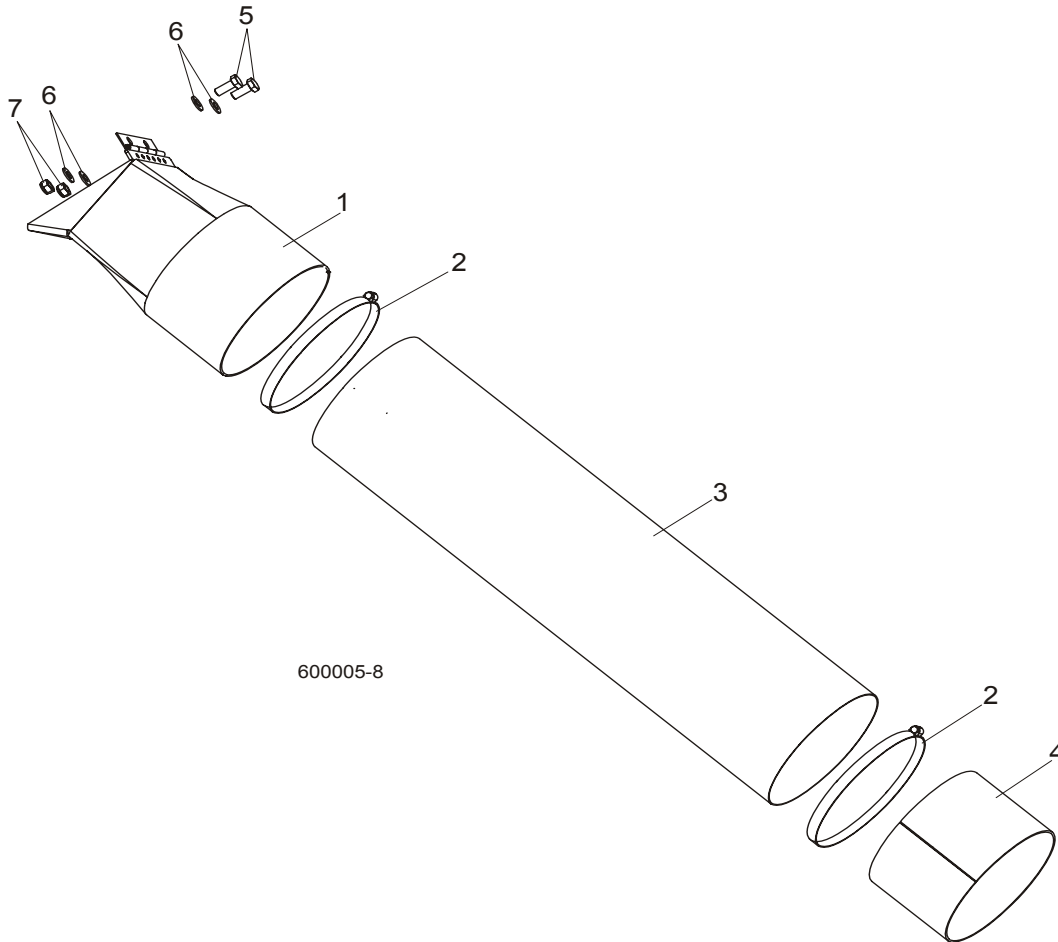

REF	DESCRIPTION (◆ Indicates Parts Available In Assemblies Only)	PART #	QTY.	
1	CHUTE WELDMENT, SAWDUST	089352-1	1	
2	CLAMP, 152 MM	089358	2	
3	TUBE, SAWDUST CHUTE	090153	1	
4	TUBE, CHUTE END	090126-1	1	
5	BOLT, M8X20-8.8-B HEX HEAD FULL THREAD ZINC	F81002-4	2	
6	WASHER 8.4 ZINC FLAT	F81054-1	4	
7	NUT, M8-8-B HEX NYLON ZINC LOCK	F81032-2	2	

SECTION 5 CONTROL BOXES

5.1 Control Assembly, LT70 AH

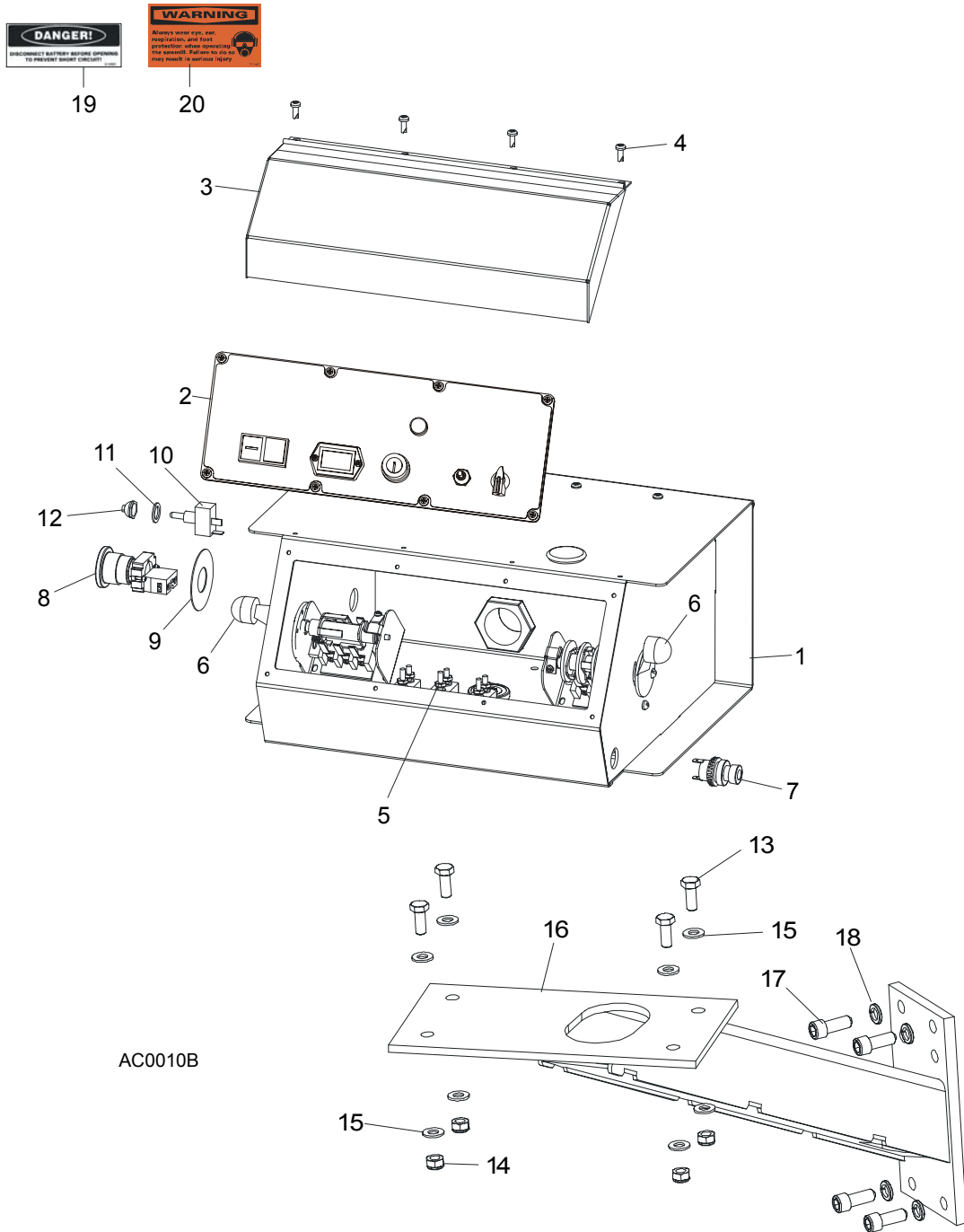

REF	DESCRIPTION (◆ Indicates Parts Available In Assemblies Only)	PART #	QTY.	
	CONTROL BOX ASSEMBLY, AC SUPER (EA20, EA25)	093022	1	
1	HOUSING, AC SUPER CONTROL BOX ASSEMBLY (EA20, EA25)	086546-1	1	◆
2	Front Control Panel & Wiring Harnesses (Section 5.4)			
3	Cover, Control Box Hinged	015304	1	
4	Screw, #10-24 x 1/2"	F05015-17	12	
5	Circuit Breakers (Section 5.3)			
6	Drum Switches (Section 5.2)			
7	Switch, Horn	E85118	1	
8	Switch, XB2 BS542 Emergency Stop	086556	1	
9	Washer, Emergency Stop Switch	086561	1	
10	Switch, Speed Control	086773	1	
11	Washer, 1/2" x 3/4" x 5/8" Nylon	P05251-1	1	
12	Boot, Speed Control Switch	P02575	1	
13	BOLT, M8 X 20-8.8-B HEX HEAD	F81002-4	4	
14	NUT, M8-8-B HEX	F81032-2	4	
15	WASHER, 8.4 FLAT	F81054-1	8	
16	MOUNT WELDMENT, STANDARD CONTROL BOX	086732-1	1	
17	BOLT,, 3/8-16 X 1" SOCKET HEAD	F05007-52	4	
18	WASHER, 10.2 SPLIT LOCK	F81055-2	4	
19	DECAL, FRONT OUTRIGGER WARNING	015400-4	1	
20	DECAL, EAR/EYE PROTECTION WARNING	S11753-4	1	

5.2 Drum Switches

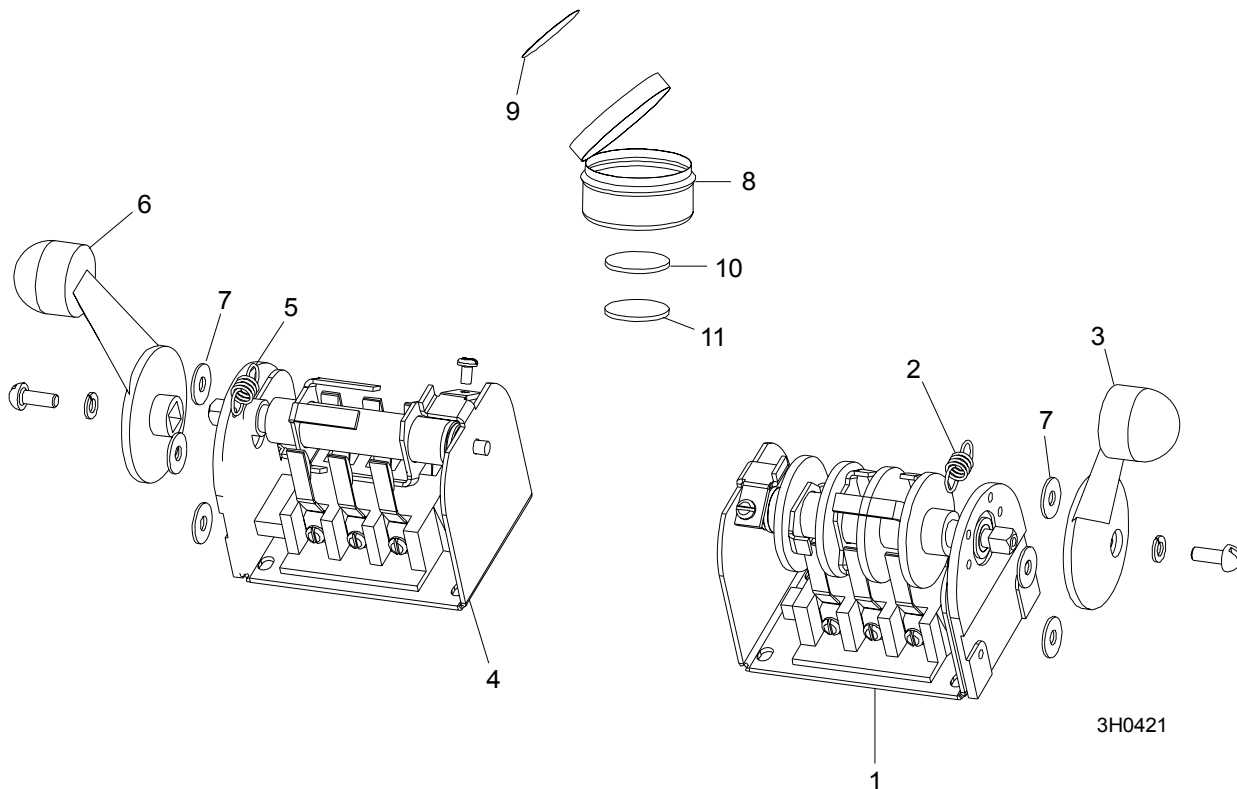

REF	DESCRIPTION (◆ Indicates Parts Available In Assemblies Only)	PART #	QTY.	
	SWITCH ASSEMBLY, UP/DOWN DRUM	E20440	1	
1	Switch, S12 Bulk Drum	E20440-B	1	◆
2	Spring, Drum Switch	P12570	1	
3	Handle, Drum Switch Replacement	P12500	1	
	SWITCH ASSEMBLY, POWER FEED DRUM	E20438	1	
4	Switch, S10 Bulk Drum	E20438-B	1	◆
5	Spring, Drum Switch	P12570	1	
6	Handle, Drum Switch Replacement	P12500	1	
7	WASHER, #8 SAE FLAT	F05011-41	6	
	CUP ASSEMBLY, DRUM SWITCH GREASE	A20463	1	
8	Cup, Plastic Container	P20464	1	◆
9	Decal, Grease Cup Label	P20467	1	
10	Pad, Velcro Loop	P20466	1	◆
11	Pad, Velcro Hook	P20465	1	◆
	Grease, High Temp Drum Switch	P20468	.011ml	◆

5.3 Circuit Breakers

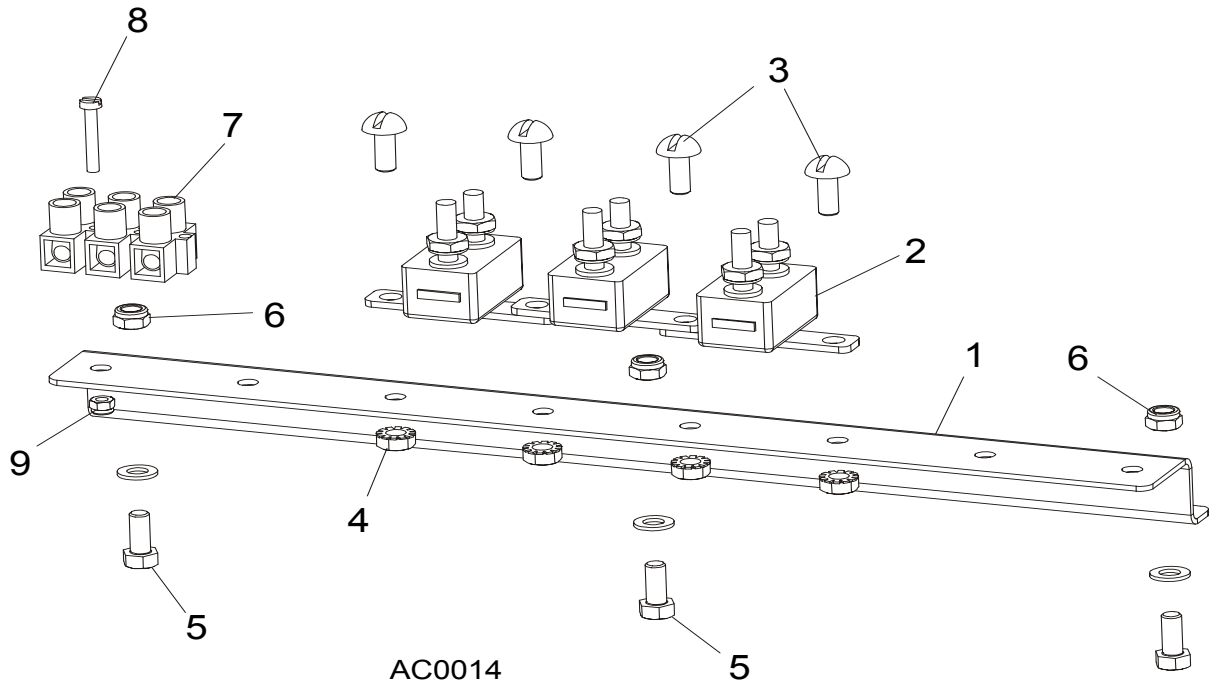

REF	DESCRIPTION (◆ Indicates Parts Available In Assemblies Only)	PART #	QTY.
	BREAKER ASSEMBLY, SAWMILL CONTROL CIRCUIT	015621	1
1	Rail, Circuit Breaker	015310	1
2	Breaker, 15 Amp Manual Reset	E20430	5
3	Screw, #8-32 X 1/2" Slotted Head	F05004-12	6
4	Nut, #8-32 Hex Self-Locking	F05010-41	6
5	BREAKER, 70 AMP MANUAL RESET PANEL MOUNT	015527	1
6	BREAKER, 50 AMP MANUAL RESET PANEL MOUNT	021256	1
7	BOOT, CIRCUIT BREAKER	021253	2
8	SCREW, #10-24 X 3/8" PHILLIPS PAN HEAD	F05004-3	3
9	NUT, #10-24 SELF LOCKING	F05010-14	3

5.4 Front Panel Assembly & Harnesses

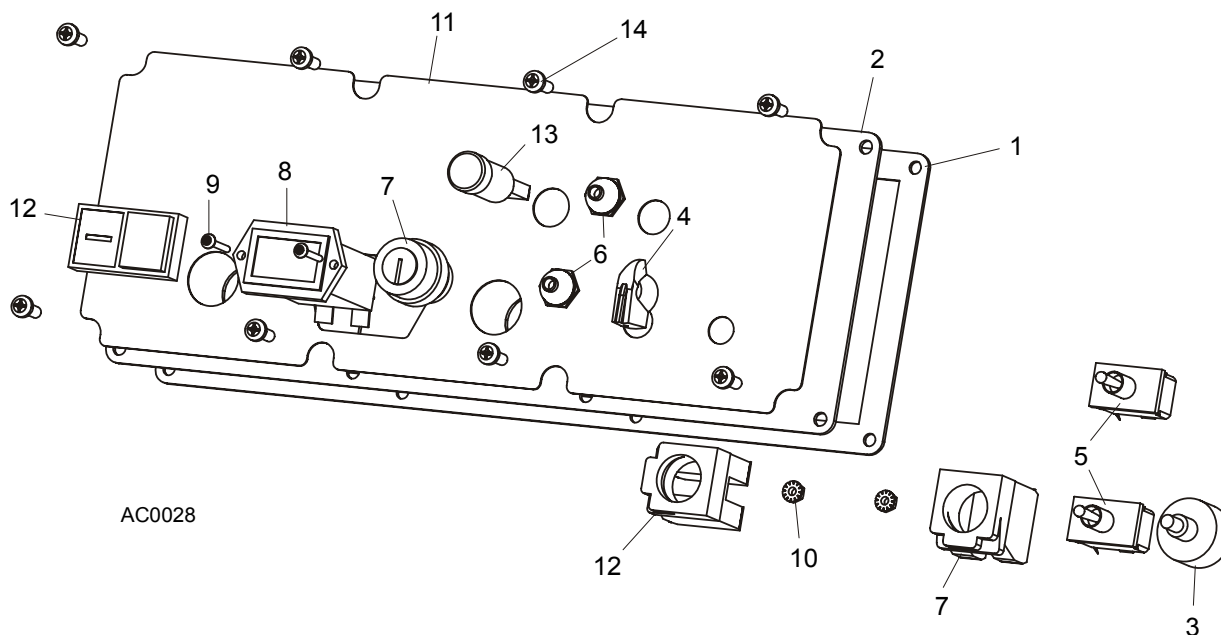

REF	DESCRIPTION (◆ Indicates Parts Available In Assemblies Only)	PART #	QTY.
	PANEL ASSEMBLY, AC SUPER CONTROL FRONT (EA20, EA25)	087387	1
1	Gasket, Front Panel	088387	1
2	Panel Weldment, Control	087316	1
3	Switch Assembly, Feed Rate	E20519	1
4	Knob, Feed Rate With Set Screw	P06257	1
5	Switch, Toggle	024200	2
6	Boot, Toggle Switch Rubber	P02575	2
7	Switch, Key	087350	1
8	Meter, Hour	015401	1
9	Screw, 6-42 x 3/4" Socket Button Head Cap Stainless Steel	F05004-93	2
10	Nut, 6-23 Self Locking	F05010-59	2
11	Decal, Control Pane	087351	1
12	Switch, START-STOP	087349	1
13	Lamp, Control	087348	1
	HARNESS ASSEMBLY, UPPER WIRING	093167	1
14	Screw, #10-24 x 1/2" Pan Head	F05015-17	8

5.5 Solenoids

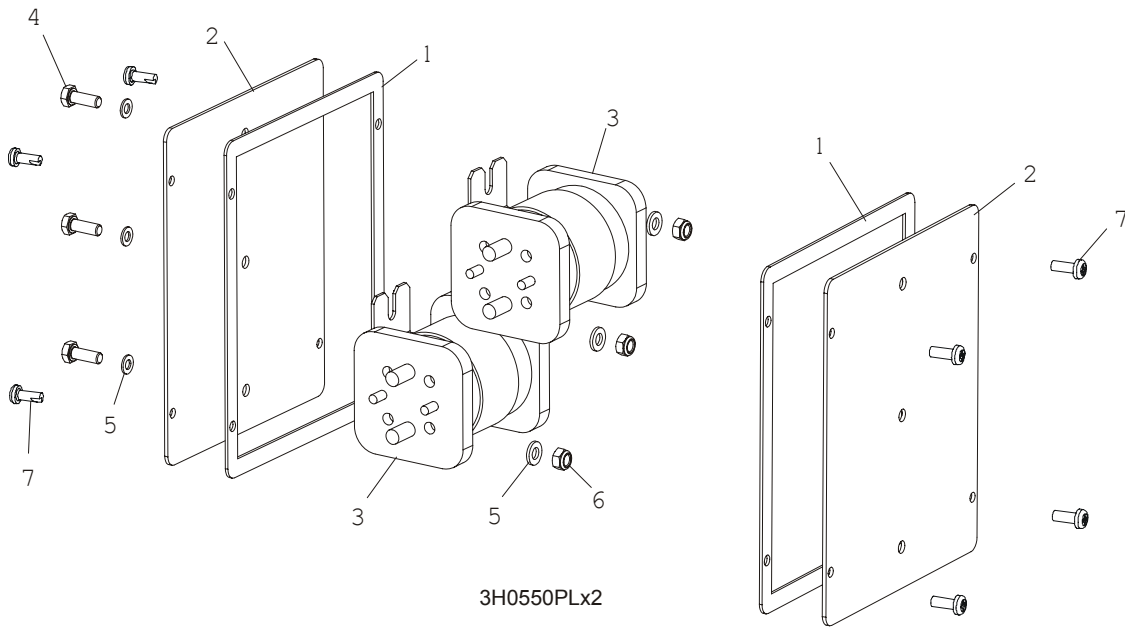

REF	DESCRIPTION (◆ Indicates Parts Available In Assemblies Only)	PART #	QTY.
1	GASKET, SIDE PANEL	015274	2
2	PANEL WELDMENT, SIDE	015307	2
3	SOLENOID, 200A 12V SPST HYDRAULIC PUMP	015470	2
4	BOLT, M6X16 5.8 HEX HEAD FULL THREAD ZINC	F81001-14	3
5	WASHER, 6.4 FLAT ZINC	F81053-1	6
6	NUT, M6-8-B HEX NYLON ZINC LOCK	F81031-2	3
	DIODE ASSEMBLY, SOLENOID COIL CHASSIS GND	087496	4
7	BOLT, #10-24 X 1/2 PHILLIPS PAN HEAD TYPE 23	F05015-17	8

SECTION 6 UP/DOWN SYSTEM

6.1 Up/Down Rollers & Covers

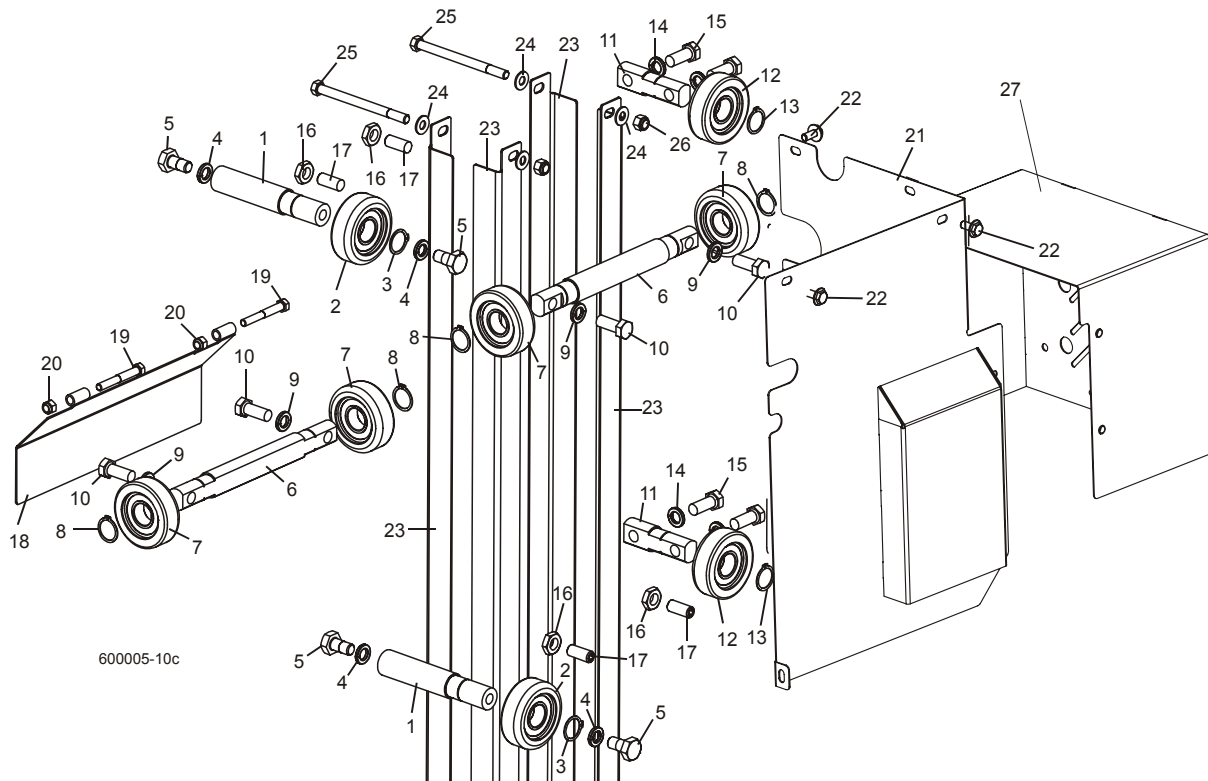

REF	DESCRIPTION (◆ Indicates Parts Available In Assemblies Only)	PART #	QTY.
	ROLLER ASSEMBLY, INSIDE UP/DOWN	089456	2
1	Shaft, Inside Up/Down Roller	088817-1	1
2	Bearing, CBK-468 Rolling	088433	1
3	Ring, Z30 Spring Retaining	F81090-23	1
4	Washer, 13 Zinc Flat	F81056-1	2
5	Bolt, M12x25-8.8 Hex Head Full Thread Zinc	F81004-31	2
	ROLLER ASSEMBLY, OUTSIDE UP/DOWN	089454	2
6	Shaft, Long Up/Down Roller	088815-1	1
7	Bearing, CBK-468 Rolling	088433	2
8	Ring, Z30 Spring Retaining	F81090-23	2
9	Washer, 10.5 Zinc Flat	F81055-1	3
10	Bolt, M10x35-8.8 Hex Head Full Thread Zinc	F81003-17	3
	ROLLER ASSEMBLY, SHORT UP/DOWN	089455	2
11	Shaft, Short Up/Down Roller	088816-1	1
12	Bearing, CBK-468 Rolling	088433	1
13	Ring, Z30 Spring Retaining	F81090-23	1

14	Washer, 10.5 Zinc Flat	F81055-1	2	
15	Bolt, M10x35-8.8 Hex Head Full Thread Zinc	F81003-17	2	
16	NUT, M10-04-W HEX ZINC THIN	F81033-6	4	
17	SCREW, GN 913.3-M10-40-MS SET	F81003-65	4	
18	COVER WELDMENT, UP/DOWN ROLLER	089483-1	1	
19	BOLT, M8X16-8.8-B HEX HEAD FULL THREAD ZINC	F81002-20	4	
20	WASHER, 8.4 ZINC FLAT	F81054-1	9	
21	GUARD WELDMENT, RA-08 UP/DOWN GEAR BOX SIDE PTD	091319-1	1	
22	BOLT, M8X12-8.8 HEX HEAD FULL THREAD ZINC	F81002-6	5	
23	ANGLE, MAST TUBE STAINLESS	088492	4	
24	WASHER, 10.5 ZINC FLAT	F81055-1	12	
25	BOLT, M10X125-8.8 HEX HEAD ZINC	F81003-18	4	
26	NUT, M10-8-B HEX NYLON ZINC LOCK	F81033-1	4	
27	GUARD, UP/DOWN MOTOR PAINTED	090501-1	1	

6.2 Blade Height Scale

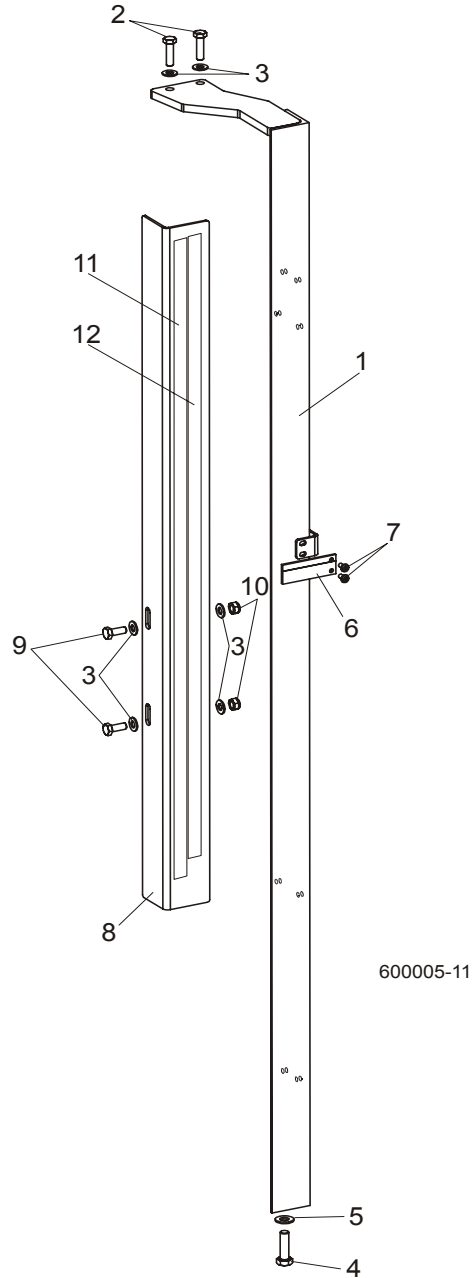

REF	DESCRIPTION (◆ Indicates Parts Available In Assemblies Only)	PART #	QTY.
1	MOUNT WELDMENT, SCALE PAINTED	088554-1	1
2	BOLT, M8 x 30-8.8-B HEX HEAD FULL THREAD ZINC	F81002-7	2
3	WASHER, 8.4 ZINC FLAT	F81054-1	6
4	BOLT, M10 x 35-8.8 HEX HEAD FULL THREAD ZINC	F81003-17	1
5	WASHER, 10.5 ZINC FLAT	F81055-1	1

6	INDICATOR, BLADE HEIGHT SCALE	094821	1	
7	SCREW, #10-24 X 3/8 PHILLIPS PAN HEAD ZINC	F05004-3	2	
8	ANGLE, SCALE MOUNT	088785-1	1	
9	BOLT, M8 X 20-8.8-B HEX HEAD FULL THREAD ZINC	F81002-4	2	
10	NUT, M8-8-B HEX NYLON ZINC LOCK	F81032-2	2	
11	DECAL, METRIC SCALE	S11711	1	
12	DECAL, 16-40 MM METRIC SCALE	P12040-1	1	

6.3 Up/Down Chain & Sprockets

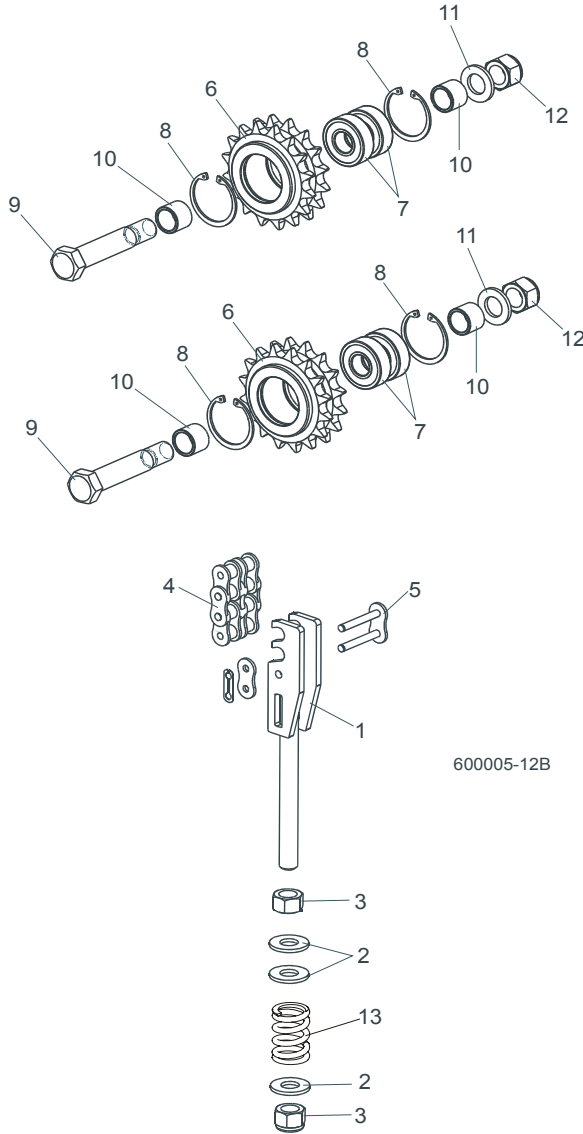

REF	DESCRIPTION (◆ Indicates Parts Available In Assemblies Only)	PART #	QTY.
1	TENSIONER WELDMENT, UP/DOWN CHAIN ZINC	088551-1	1
2	WASHER, 13 ZINC FLAT	F81056-1	3
3	NUT, M12-8 HEX NYLON ZINC LOCK	F81034-2	2
4	CHAIN, 10B-2 113-LINK UP/DOWN	088672	1
5	LINK, 10B-2Pz MASTER	088673	1
	SPROCKET ASSEMBLY, UP/DOWN IDLER	088470	2
6	Sprocket, Zinc	088471-1	1
7	Bearing, 6203-2RS FLT Rolling	086114	2

8	Ring, W40 Spring Retaining	F81090-3	2	
9	Bolt, M16D1F6 x 90-8.8 Hex Fit Short Thread Zinc	F81006-15	1	
10	Spacer, Idler Zinc	088792-1	2	
11	Washer, 17 Zinc Flat	F81058-1	1	
12	Nut, M16-8 Hex Nylon Zinc Lock	F81036-2	1	
13	Spring, 14x30x3,2	090797	1	

6.4 Up/Down Drive Assembly

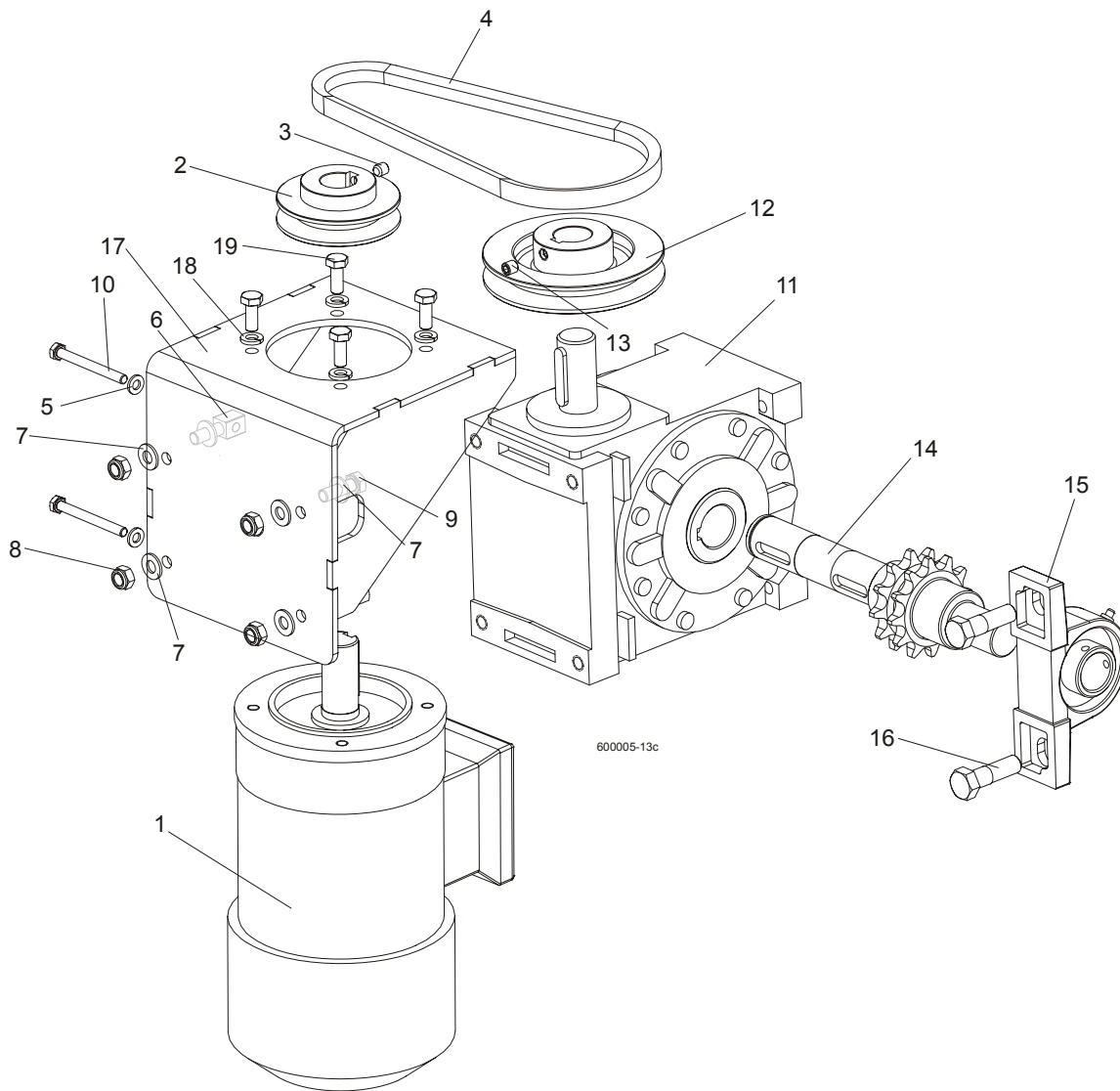

REF	DESCRIPTION (◆ Indicates Parts Available In Assemblies Only)	PART #	QTY.
	MOTOR W/MOUNT BRACKET, AC UP/DOWN	090493	1
1	AC Motor, 2 gear STKg90 6/4L2 IMB14/162	086530	1
2	Pulley, AC Motor Painted	090497-1	1
3	Screw, M8x8-33H Hex Socket Set Flat Point Zinc	F81014-1	1
4	V-Belt, HA-670	091328	1
5	Washer, 6.4 Zinc Flat	F81053-1	2
6	Bolt, Special - Zinc Plated	088962-1	2
7	Washer, 8.4 Zinc Flat	F81054-1	8
8	Nut, M8-8-B Hex Nylon Zinc Lock	F81032-2	4
9	Bolt, M8X25-8.8-B Hex Head Full Thread Zinc	F81002-5	2
10	Bolt, M6x60-8.8 Hex Head Full Thread Zinc	F81001-9	2

	GEAR BOX ASSEMBLY, UP/DOWN DRIVE	091310	1	
11	Gear Box, RA-08/64/WBS/D1/S,N/V5	091306	1	
12	Pulley, Up/Down Gear Painted	091308-1	1	
13	Screw, M8x8-33H Hex Socket Set Flat Point Zinc	F81014-1	1	
14	Output Shaft W/Sprocket, Up/Down Drive	091311	1	
15	Bearing Assembly, UCP205 CX	088468	1	
16	Bolt, M12 x 40-8.8 Hex Head Zinc	F81004-1	1	
17	BRACKET, AC UP/DOWN MOTOR MOUNT PTD	090494-1	1	
18	WASHER 8.2 SPLIT LOCK ZINC	F81054-4	4	
19	BOLT, M8 X 20-8.8-B HEX HEAD FULL THREAD ZINC	F81002-4	4	

SECTION 7 FEED SYSTEM & TRACK ROLLERS

7.1 Upper Track Rollers And Wipers

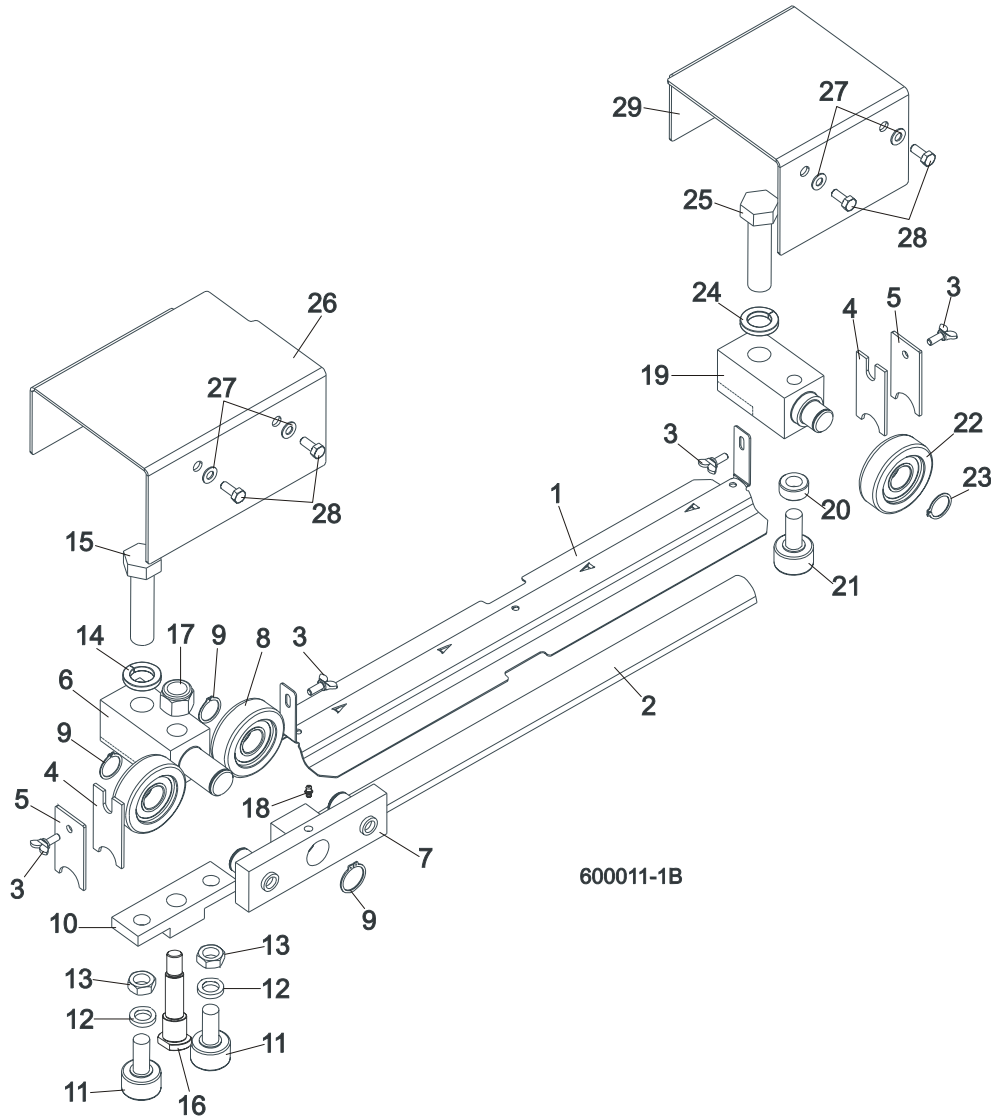

REF	DESCRIPTION (◆ Indicates Parts Available In Assemblies Only)	PART #	QTY.
1	COVER, MIDDLE TRACK	092868-1	1
2	STRIP, FELT	S09915	1
3	SCREW, M6X16 DIN 316 WING	F81001-16	4
4	WIPER, TOP RAIL	M04113	2
5	PLATE, TRACK WIPER	088559-1	2
	ROLLER ASSEMBLY, UPPER TANDEM TRACK	088530	1
6	Block, Tandem Roller Mount	088532	1

Feed System & Track Rollers

Upper Track Rollers And Wipers

7

7	Block Assembly, Tandem Roller	088535	1	
8	Bearing, CBK-468 Rolling	088433	2	
9	Ring, Z30 Spring Retaining	F81090-23	2	
10	Block, Cam Follower Mount	088520	1	
11	Bearing, Cam Follower (McGill)	012797	2	
12	Washer, 16.3 Split Zinc Lock	F81058-2	2	
13	Nut, 5/8"-18 Zinc	F05010-11	2	
14	Washer, Z24.5 Split Zinc Lock	F81061-4	1	
15	Bolt, M24 x 2 x 90-8.8 Hex Head Full Thread Zinc	F81009-2	1	
16	Pin, Cam Follower Mount	088531	1	
17	Nut, M16-8 Hex Nylon Zinc Lock	F81036-2	1	
18	Fitting, M6 Straight Grease	086280	1	
	ROLLER ASSEMBLY, REAR UPPER TRACK	088529	1	
19	Block, Rear Upper Roller Mount	088528	1	
20	Spacer, Cam Follower	088536	1	
21	Bearing, Cam Follower (McGill)	012797	1	
22	Roller, CBK-468	088433	1	
23	Ring, Z30 Spring Retaining	F81090-23	1	
24	Washer, Z24.5 Split Zinc Lock	F81061-4	1	
25	Bolt, M24x2x90-8.8 Hex Head Full Thread Zinc	F81009-2	1	
26	COVER, TANDEM ROLLER	088526-1	1	
27	WASHER, 6.4 ZINC FLAT	F81053-1	4	
28	BOLT, M6X16 8.8 HEX HEAD FULL THREAD ZINC	F81001-15	4	
29	COVER, REAR UPPER ROLLER	088527-1	1	

7.2 Power Feed Assembly

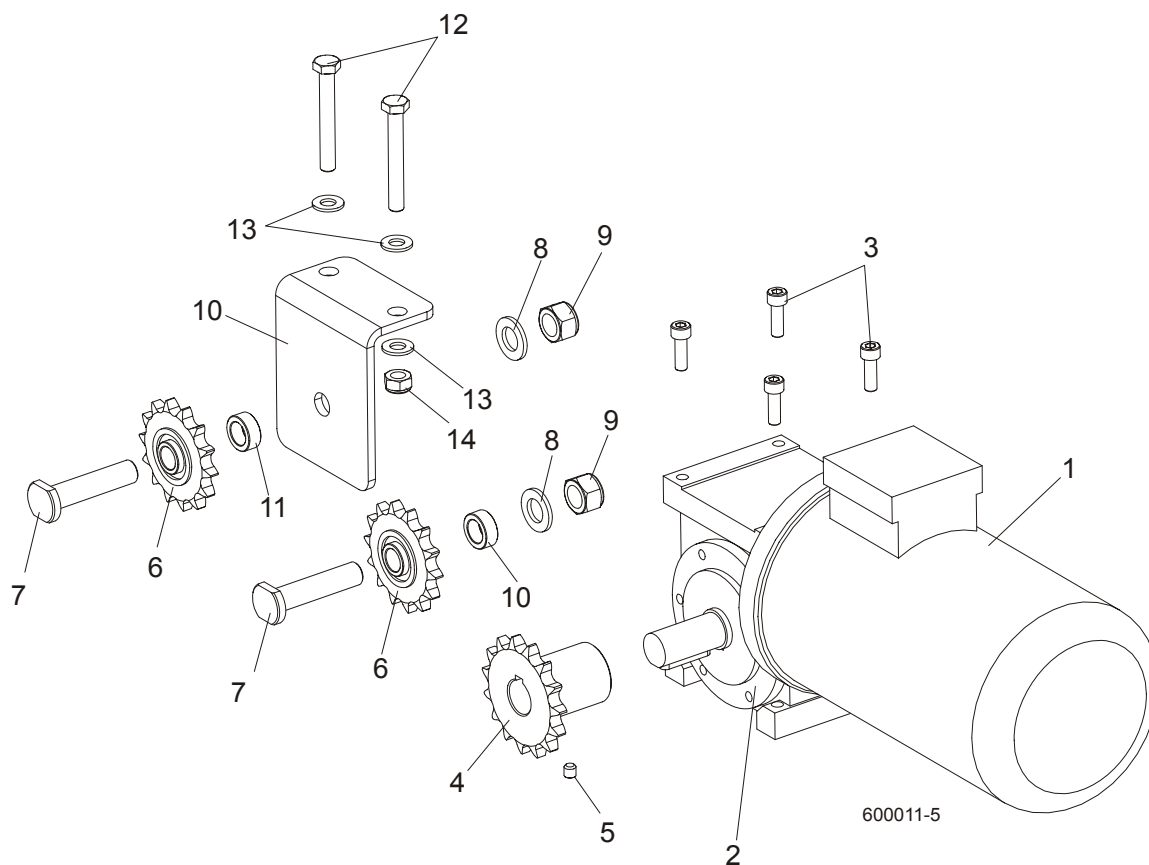

REF	DESCRIPTION (◆ Indicates Parts Available In Assemblies Only)	PART #	QTY.
1	Electric motor 1,1kW AC	090104	1
2	RA-0,5/7,5/D3/S/B8 I.3 koln.160/19 B14/1	088565	1
3	SCREW, M8x25 -8.8 HEX SOCKET HEAD CAP	F81002-21	4
4	SPROCKET, 10B Z15 ZINC	088541-1	1
5	SCREW, M8x8-33H HEX SOCKET SET FLAT POINT ZINC	F81014-1	2
6	SPROCKET, KSR 16.L0.10.10.14.08 W/BEARING	088867	2
7	PIN, ZINC SPROCKET MOUNT	088994-1	2
8	WASHER, 17 ZINC FLAT	F81058-1	2
9	NUT, M16-8 HEX NYLON ZINC LOCK	F81036-2	2
10	BRACKET, POWER FEED SPROCKET MOUNT	088507-1	1
11	SPACER, POWER FEED SPROCKET	088550-1	1
12	BOLT, M10x75-8.8 HEX HEAD ZINC	F81003-15	2
13	WASHER, 10.5 ZINC FLAT	F81055-1	4
14	NUT, M10-8-B HEX NYLON ZINC LOCK	F81033-1	2

7.3 Feed Chain/Stop, LT70 S/M

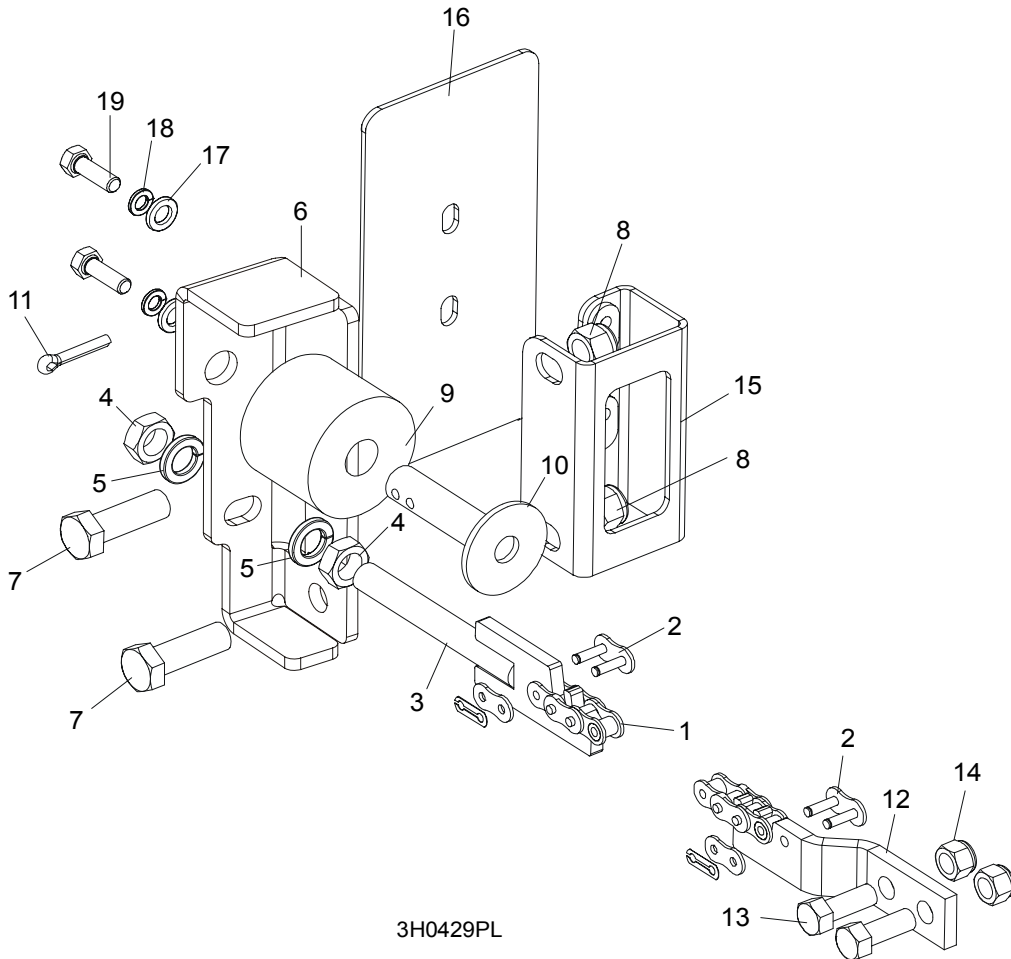

3H0429PL

REF	DESCRIPTION (◆ Indicates Parts Available In Assemblies Only)	PART #	QTY.
1	CHAIN, 10B-1-375 (5.95M) LT70S FEED	090427	1
	CHAIN, 10B-1-457 (7.25M) LT70M FEED	090370	1
2	LINK, 10B-1Pz MASTER	088671	2
3	TENSIONER WELDMENT, POWER FEED CHAIN ZINC-PLATED	086818-1	1
4	NUT, M12-5 HEX JAM	F81034-4	2
5	WASHER, 12.2 SPLIT LOCK	F81056-2	2
6	BRACKET, FEED CHAIN REAR MOUNT	087628-1	1
7	BOLT, M12 X 40 8.8 HEX HEAD GRADE 5	F81004-4	2
8	NUT, M12-8 HEX NYLON LOCK	F81034-2	2
	STOP KIT, RUBBER CARRIAGE	K09630	2
9	Stop, Rubber Carriage	P12165	1
10	Pin, Rubber Carriage Stop	W09293	1
11	Pin, 3/16" X 1" Cotter	F05012-21	1

7 Feed System & Track Rollers

Feed Chain/Stop, LT70 S/M

12	BRACKET, FRONT FEED CHAIN MOUNT	015008	1	
13	BOLT, 3/8-16 X 1" HEX HEAD	F05007-7	2	
14	NUT, 3/8-16 HEX NYLON LOCK	F05010-10	2	
15	BRACKET WELDMENT, REAR MAIN TUBE COVER MOUNT	087105-1	1	
16	COVER, REAR MAIN TUBE	015023	1	
17	WASHER, 8.4 FLAT	F81054-1	2	
18	WASHER, 8.2 SPLIT LOCK	F81054-4	2	
19	BOLT, 5/16-18 X 1" HEX HEAD	F05006-1	2	

7.4 Lower Track Rollers

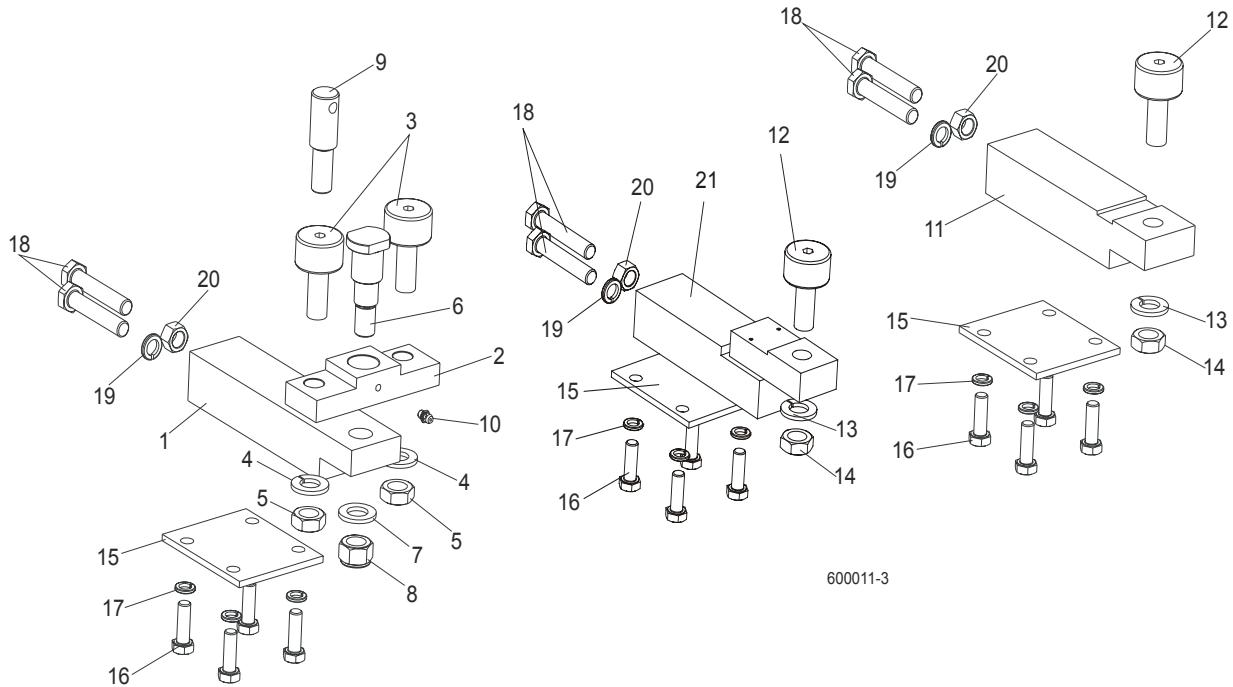

REF	DESCRIPTION (◆ Indicates Parts Available In Assemblies Only)	PART #	QTY.
	BLOCK ASSEMBLY, VERTICAL MAST ALIGNMENT DOUBLE	088523	1
1	Block, Vertical Mast Alignment Double	088517	1
2	Block, Cam Follower Mount	088520	1
3	Bearing, Cam Follower (McGill)	012797	2
4	Washer, 16.3 Split Zinc Lock	F81058-2	2
5	Nut, 5/8"-18 Zinc	F05010-11	2
6	Pin, Cam Follower Mount	088521	1
7	Washer, 17 Zinc Flat	F81058-1	1
8	Nut, M16-8 Hex Nylon Zinc Lock	F81036-2	1
9	Pin, Safety Lock	088519	1
10	Fitting, M6 Straight Grease	086280	1
	BLOCK ASSEMBLY, VERTICAL MAST ALIGNMENT SINGLE	088524	1
11	Block, Vertical Mast Alignment Single	088518	1
12	Bearing, Cam Follower (McGill)	012797	1
13	Washer, 16.3 Split Zinc Lock	F81058-2	1
14	Nut, 5/8"-18 Zinc	F05010-11	1
15	PLATE, LOWER TRACK ROLLER RETAINER	088516	3
16	BOLT, M10X30-5.8 HEX HEAD FULL THREAD ZINC	F81003-2	12
17	WASHER, 10.2 SPLIT ZINC LOCK	F81055-2	12
18	BOLT, M12X1.25X65-8.8 HEX HEAD FULL THREAD ZINC	F81004-40	6

7 Feed System & Track Rollers

Lower Track Rollers

19	WASHER, Z12.2 SPLIT ZINC LOCK	F81056-2	3	
20	NUT, M12X1.25-8 ZINC HEX	F81034-8	3	
21	BLOCK WELDMENT, LOWER TRACK ROLLER MOUNT	091425	1	

SECTION 8 BED FRAME ASSEMBLY

8.1 Bed Rail Assembly, Front And Rear

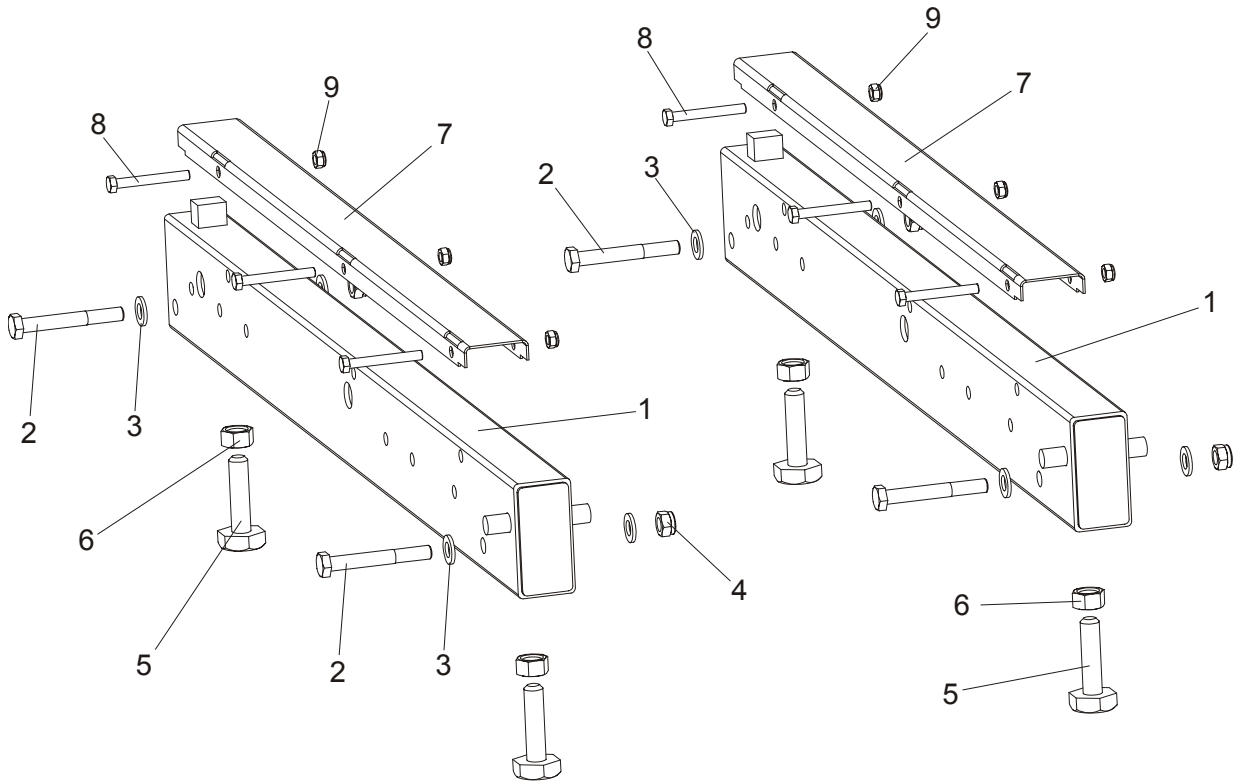

REF	DESCRIPTION (◆ Indicates Parts Available In Assemblies Only)	PART #	QTY.
1	BED RAIL ASSEMBLY, REAR PAINTED	091555	2
2	Bolt, M12 x 90-8.8 Hex Head	F81004-2	4
3	Washer, 13 SAE Flat	F81056-1	8
4	Nut, M12-8 Hex Nylon Lock	F81034-2	4
5	Bolt, M16 Bed Rail Adjustment	086809	4
6	Nut, M16-5-B Zinc Hex Head	F81036-5	4
7	COVER, STAINLESS STEEL BED RAIL	S09944	2
8	BOLT, M8X65-5.8 ZINC HEX HEAD	F81002-3	6
9	NUT, M8-8-B HEX NYLON ZINC LOCK	F81032-2	6

8 Bed Frame Assembly

Bed Rail Assembly, Front Middle

8.2 Bed Rail Assembly, Front Middle

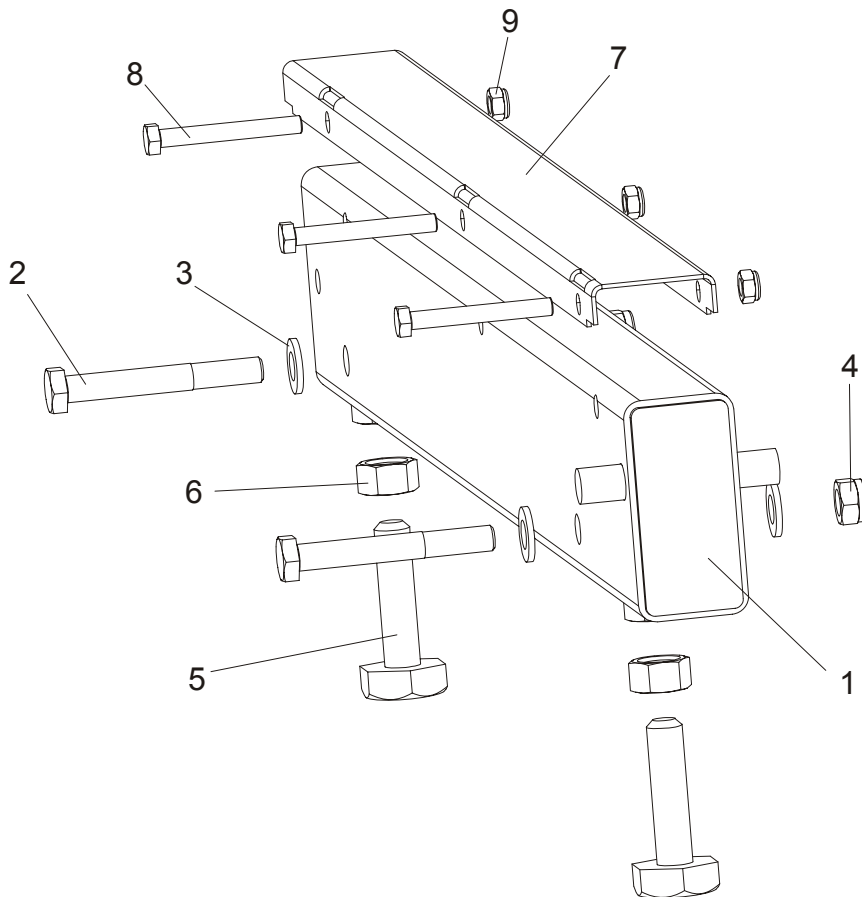

REF	DESCRIPTION (◆ Indicates Parts Available In Assemblies Only)	PART #	QTY.
1	BED RAIL ASSEMBLY, FRONT MIDDLE	091556	1
2	Bolt, M12 x 90-8.8 Hex Head	F81004-2	2
3	Washer, 13 SAE Flat	F81056-1	4
4	Nut, M12-8 Hex Nylon Lock	F81034-2	2
5	Bolt, M16 Bed Rail Adjustment	086809	2
6	Nut, M16-5-B Hex Head Zinc	F81036-5	2
7	COVER, STAINLESS STEEL BED RAIL	S09944	2
8	BOLT, M8X65-5.8 ZINC HEX HEAD	F81002-3	3
9	NUT, M8-8-B HEX NYLON ZINC LOCK	F81032-2	3

8.3 Bed Rail Assembly, Rear Middle

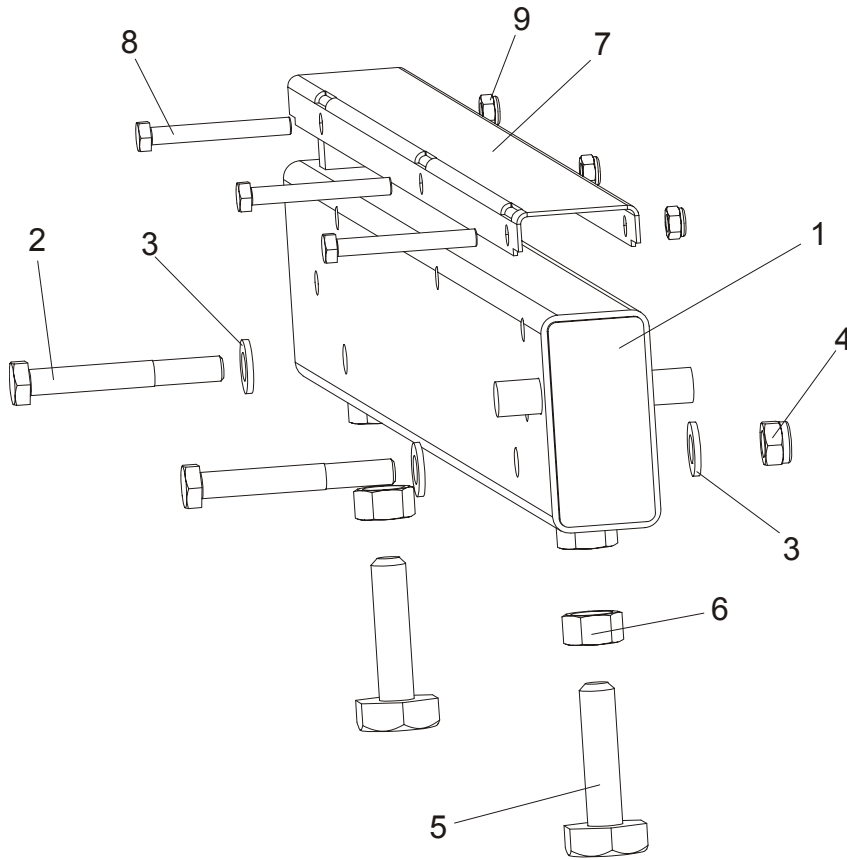

REF	DESCRIPTION (◆ Indicates Parts Available In Assemblies Only)	PART #	QTY.
1	BED RAIL ASSEMBLY, REAR MIDDLE PAINTED	091557	1
2	Bolt, M12 x 90-8.8 Hex Head	F81004-2	2
3	Washer, 13 SAE Flat	F81056-1	4
4	Nut, M12-8 Hex Nylon Lock	F81034-2	2
5	Bolt, M16 Bed Rail Adjustment	086809	2
6	Nut, M16-5-B Hex Head Zinc	F81036-5	2
7	COVER, STAINLESS STEEL BED RAIL	S09944	2
8	BOLT, M8X65-5.8 HEX HEAD ZINC	F81002-3	3
9	NUT, M8-8-B HEX NYLON ZINC LOCK	F81032-2	3

8 Bed Frame Assembly

Clamp Mount Assembly, Front (A/DH5/7)

8.4 Clamp Mount Assembly, Front (A/DH5/7)

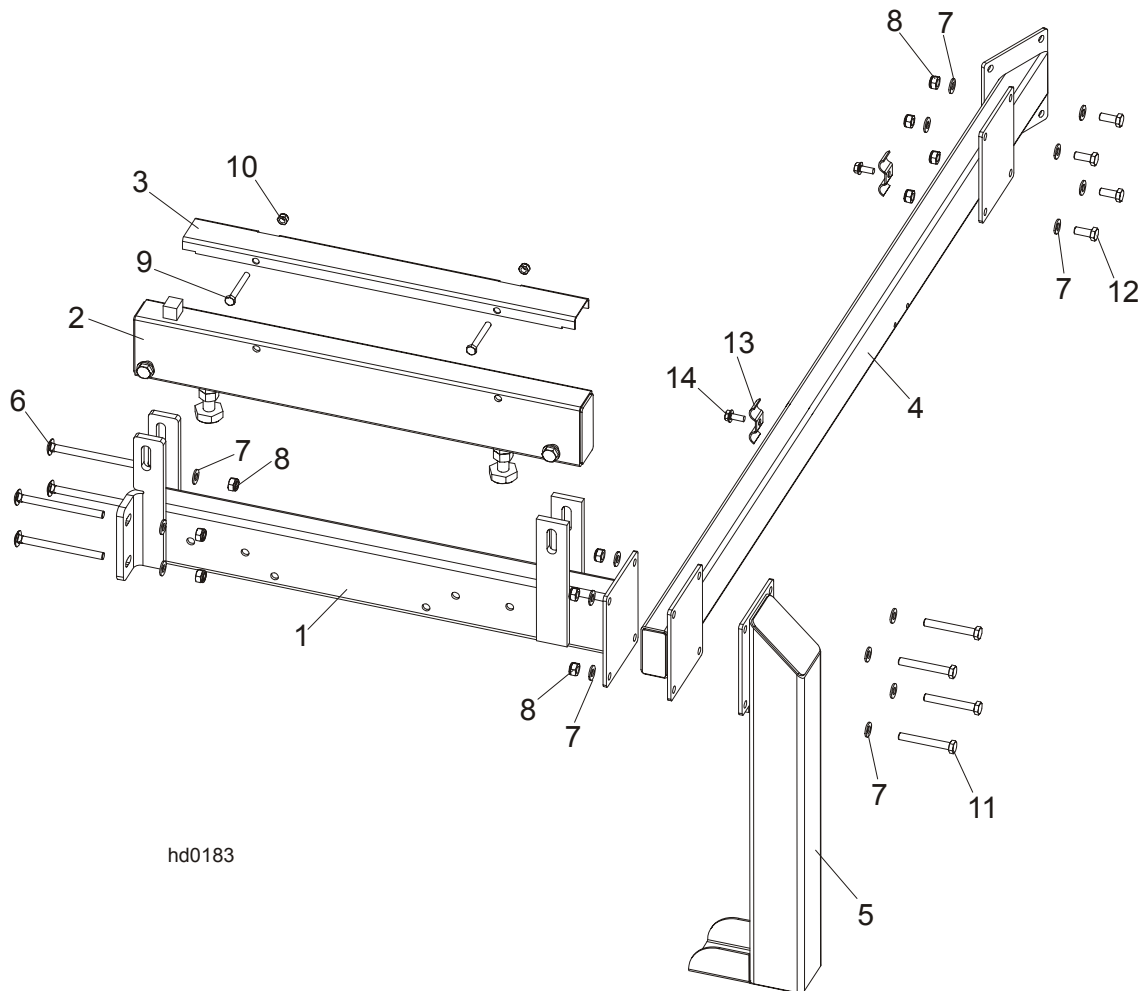

REF	DESCRIPTION (◆ Indicates Parts Available In Assemblies Only)	PART #	QTY.
	CLAMP MOUNT ASSEMBLY - FRONT	092937	1
1	Bed Rail Assembly, Front	092903-1	1
2	Bed Rail AH5/DH5	095131-1	1
3	Cover, 22.75 SS LT50 Pivot	S13012	1
4	Tube Weldment, Bed Front	092904-1	1
5	Leg, Stationary Left	087450-1	1
6	Bolt, M10 X 125-8.8 Carriage Head	F81003-34	4
7	Washer, M10 Flat Zinc	F81055-1	20
8	Nut, M10 Hex Nylon Zinc Lock	F81033-1	12
9	Bolt, M8 x 65mm Hex Head Zinc Grade 5.8	F81002-3	2
10	Nut, M8 Hex Nylon Zinc Lock	F81032-2	2
11	Bolt, M10x75-8.8 Hex Head Zinc	F81003-15	4

Bed Frame Assembly

Clamp Mount Assembly, Front (A/DH5/7)

8

12	Bolt, M10-1.5x25mm Hex Head Grade 8.8	F81003-11	4	
13	Plate, 1/4 Hose Clamp Painted	S09245	2	
14	Screw, 5/16-18x3/4 Self-tapping	F05015-30	2	

8 Bed Frame Assembly

Clamp Mount Assembly, Rear (A/DH5/7)

8.5 Clamp Mount Assembly, Rear (A/DH5/7)

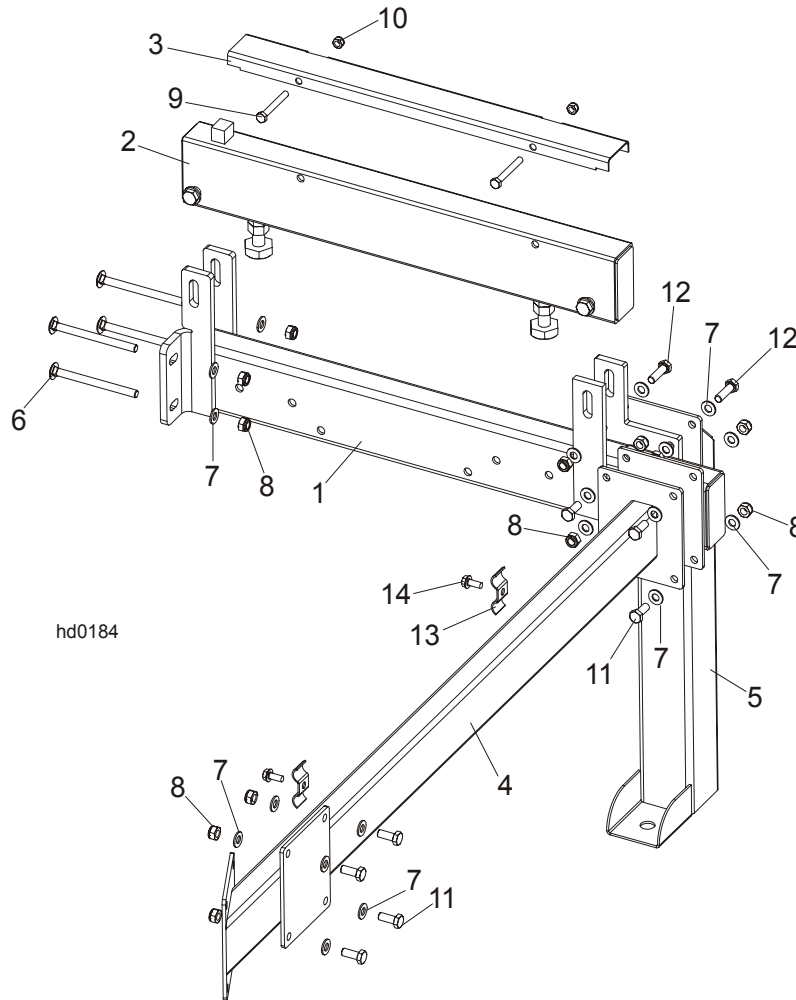

REF	DESCRIPTION (◆ Indicates Parts Available In Assemblies Only)	PART #	QTY.
	CLAMP MOUNT ASSEMBLY - REAR	092938	1
1	Bed Rail Assembly, Rear	092902-1	1
2	Bed Rail AH5/DH5	095131-1	1
3	Cover, 22.75 SS LT50 Pivot	S13012	1
4	Tube Weldment, Bed Rear	092907-1	1
5	Leg, Stationary Left	087450-1	1
6	Bolt, M10 X 125-8.8 Carriage Head	F81003-34	4
7	Washer, M10 Flat Zinc	F81055-1	28
8	Nut, M10 Hex Nylon Zinc Lock	F81033-1	16
9	Bolt, M8 x 65-5.8 Hex Head Zinc	F81002-3	2
10	Nut, M8 Hex Nylon Lock Zinc	F81032-2	2
11	Bolt, M10x25-8.8Hex Head Full Thread Zinc	F81003-11	4

Bed Frame Assembly

Clamp Mount Assembly, Rear (A/DH5/7)

8

12	Bolt, M10x35-8.8 Hex Head Full Thread Zinc	F81003-17	4	
13	Plate, 1/4 Hose Clamp Painted	S09245	2	
14	Screw, 5/16-18x3/4 Self-tapping	F05015-30	2	

8 Bed Frame Assembly

Leg, Stationary

8.6 Leg, Stationary

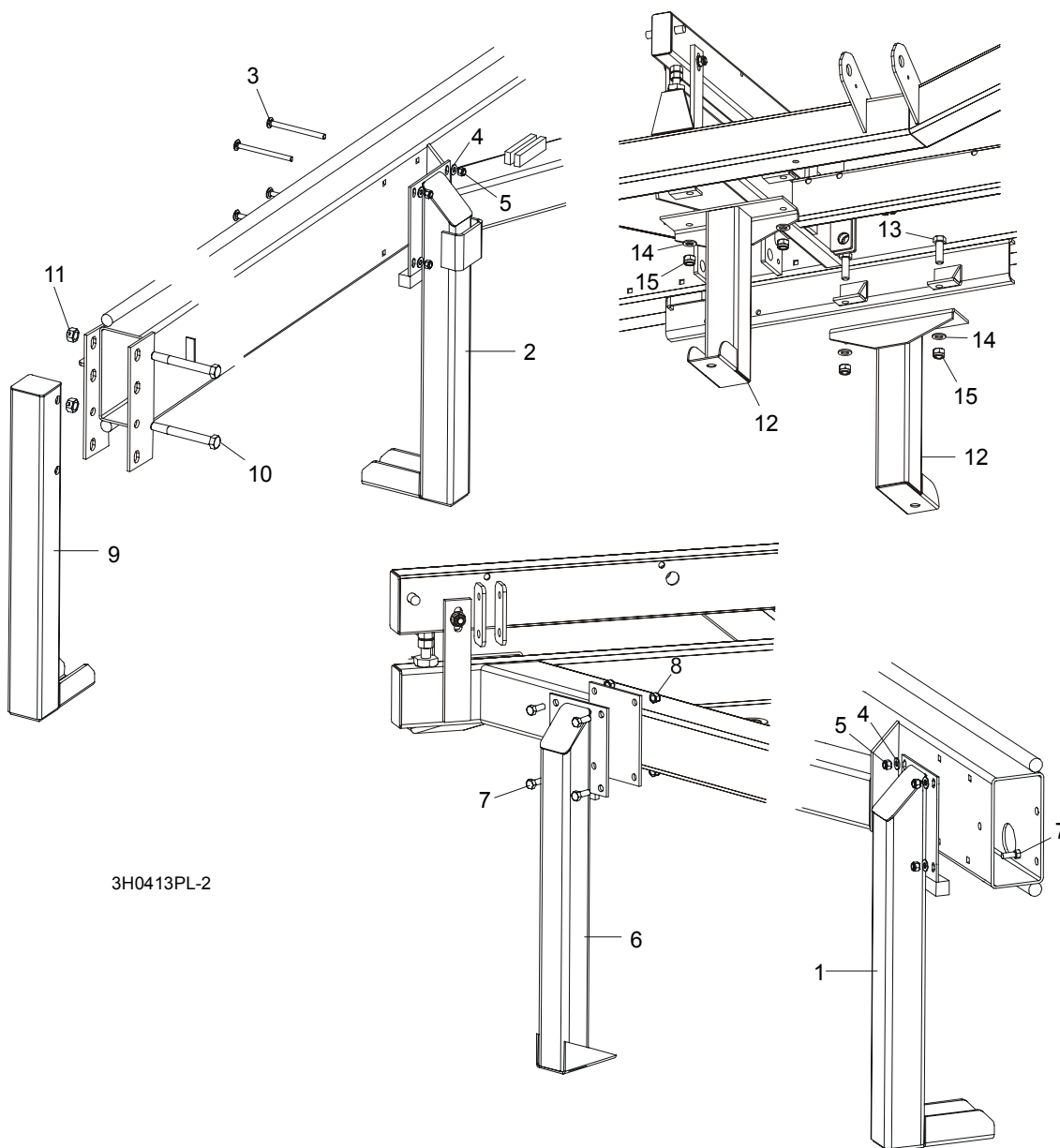

3H0413PL-2

REF	DESCRIPTION (◆ Indicates Parts Available In Assemblies Only)	PART #	QTY.
1	LEG, LONG RIGHT STATIONARY (1 REQ'D FOR LT30; 3 REQ'D FOR LT40)	087451-1	1/3
2	LEG, LONG STATIONARY W/BOARD RETURN TABLE BRACKET	087449-1	1
3	BOLT, M10 X 120-8.8 CARRIAGE HEAD	F81003-33	8/12
4	WASHER, 10.5 FLAT	F81055-1	8/16
5	NUT, M10-8-B HEX NYLON LOCK	F81033-1	8/16

Bed Frame Assembly

Leg, Stationary

8

6	LEG, SHORT LEFT STATIONARY	087450-1	2	
7	BOLT, M10 X 25-8.8 HEX HEAD	F81003-11	12	
8	NUT, M10-8-B HEX NYLON LOCK	F81033-1	12	
9	LEG, FRONT STATIONARY	087452-1	1	
10	BOLT, M16 X 140-8.8 HEX HEAD GRADE 5	F81006-4	2	
11	NUT, M16-8 HEX LOCK ZINC LOCK	F81036-2	2	
12	LEG, MIDDLE STATIONARY	087093-1	2	
13	BOLT, M16 X 50-8.8 HEX HEAD FULL THREAD ZINC	F81006-7	4	
14	WASHER, 17 FLAT ZINC	F81058-1	4	
15	NUT, M16-8 HEX NYLON ZINC LOCK	F81036-2	4	

8 Bed Frame Assembly

Board Return Table Assembly

8.7 Board Return Table Assembly

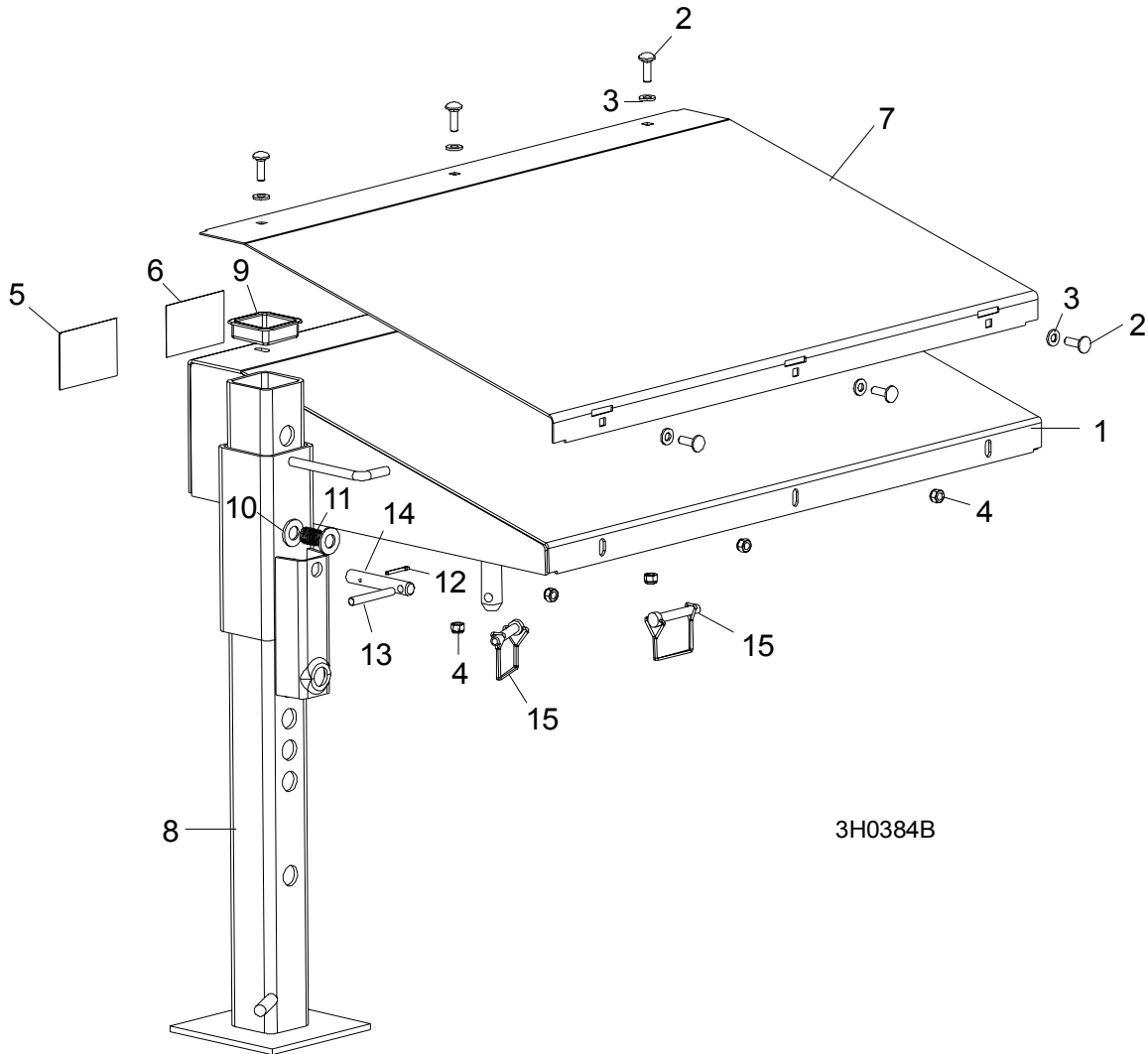

3H0384B

REF	DESCRIPTION (◆ Indicates Parts Available In Assemblies Only)	PART #	QTY.	
	TABLE ASSEMBLY, BOARD RETURN	091397	1	
1	Table Weldment, Board Return	091225-1	1	◆
2	Bolt, 5/16-18 x 1" Carriage Head	F81002-1	6	
3	Washer, 8.4 Flat Zinc	F81054-1	6	
4	Nut, M8-8-B Hex Nylon Zinc Lock	F81032-2	6	
5	Decal, Board Return Danger	015365	1	
6	Decal, Board Return Table Warning	016077	1	
7	Plate, Return Table Stainless Steel	091396	1	
8	Leg Weldment, Painted Outrigger	089691-1	1	
9	Cap, Outrigger Leg	089710	1	

10	Washer, 21 Flat Zinc	F81059-2	2	
11	Spring, 21x38x2 Diameter Stainless Steel Compression	087040	1	
12	Pin, 4x25 Cotter	F81043-2	1	
13	Pin, 8x65 Roll	F81046-1	1	
14	Pin, Outrigger Pull	087012-1	1	
15	Pin, 3/8 X 2 1/4" Square Wire Lock	014151	2	

8 Bed Frame Assembly

Pivot Bed Rail Assembly

8.8 Pivot Bed Rail Assembly

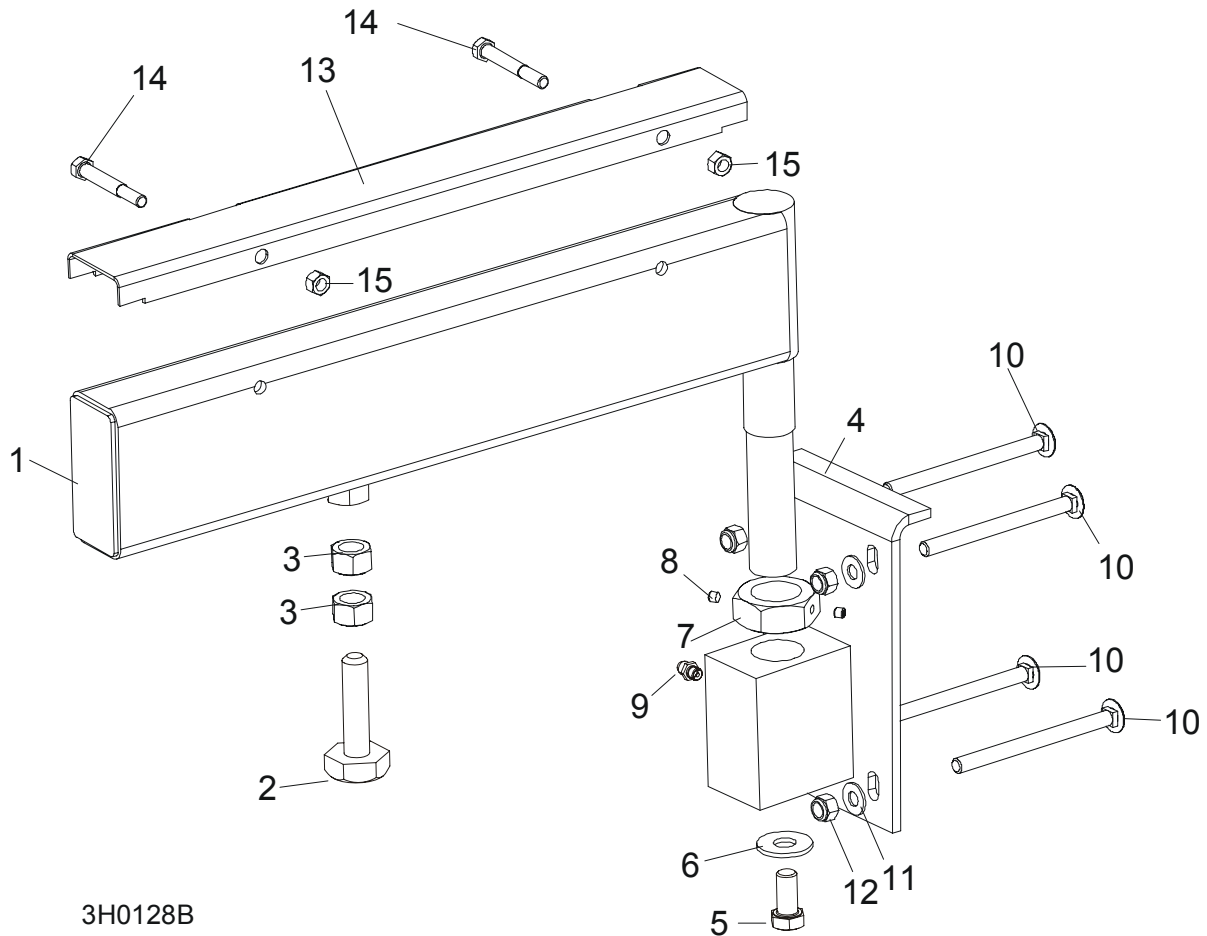

3H0128B

REF	DESCRIPTION (◆ Indicates Parts Available In Assemblies Only)	PART #	QTY.
	PIVOT BED RAIL ASSEMBLY	087829	2
	PIVOT BED RAIL ASSEMBLY	087855	2
1	Pivot Bed Rail Weldment	087852	1
	Pivot Bed Rail Weldment	087848	1
	Bolt Assembly, Bed Rail Adjustment		1
2	Bolt, Bed Rail Adjustment	086809	1
3	Nut, M16-5.8 Hex Zinc	F81036-1	2
4	Bracket, Pivot Rail Mounting	087841-1	1
5	Bolt, M12x25-8.8 Hex Head Full Thread Zinc	F81004-31	1
6	Washer, 15 Flat	F05011-52	1
7	Nut, Pivot Rail Adjustment Nut, Pivot Rail Adjustment	F81036-1 F81039-2	1
8	Screw, 1/4-28 x 1/4" Brass Tip Set	F05005-42	2
9	Fitting, 3/16" Grease	086280	1

Bed Frame Assembly

Pivot Bed Rail Assembly

8

10	BOLT, 3M10 X 120-8.8 CARRIAGE HEAD	F81003-14	2	
11	BOLT, 3/8-16 X 5" CARRIAGE HEAD	F05007-113	6	
12	WASHER, 10.5 FLAT ZINC	F81055-1	8	
13	NUT, M16-8 HEX NYLON ZINC LOCK	F81036-2	8	
	COVER KIT, PIVOT RAIL STAINLESS STEEL	015926	2	
	COVER KIT, PIVOT RAIL STAINLESS STEEL	N/A	2	
14	Cover, Stainless Steel Pivot Bed Rail	012994	1	
	Cover, Stainless Steel Pivot Bed Rail	S13012	1	
15	Bolt, M8x65-5.8 Hex Head Zinc	F81002-3	4	
16	Nut, M8-8-B Hex Nylon Zinc Lock	F81032-2	4	
	WRENCH, BED RAIL ADJUSTMENT (See Section 8.3)	015970	1	

8.9 Log Side Support Assembly (Manual)

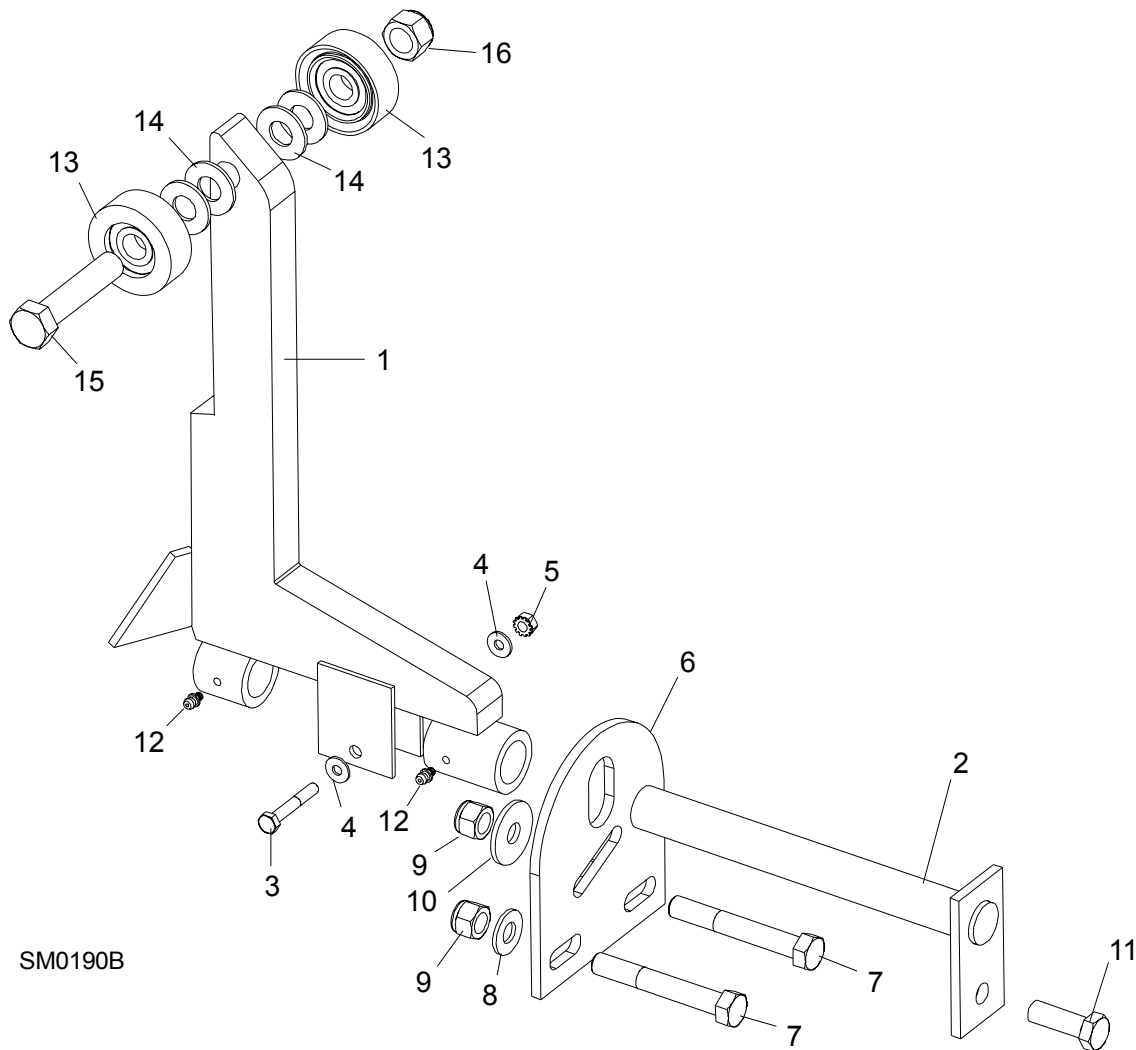

REF	DESCRIPTION (◆ Indicates Parts Available In Assemblies Only)	PART #	QTY.
	SUPPORT, LOG SIDE	092686	
1	MOUNTING KIT, LOG SIDE SUPPORT	085538-1	
2	Pin, Log Side Support Pivot	091549-1	1
3	Bolt, M8x45-8.8 Hex Head Full Thread Zinc	F81002-14	1
4	Washer, 8.4 Flat Zinc	F81054-1	2
5	Nut, M8-8-B Hex Nylon Zinc Lock	F81032-2	1
6	Plate, Log Side Support End	091591-1	1
7	Bolt, M12 x 90-8.8 Hex Head Zinc	F81004-2	2
8	Washer, 13 Flat Zinc	F81056-1	2

9	Nut, M12-8 Hex Nylon Zinc Lock	F81034-2	3	
10	Washer, .5" x 1.63" x 11" Ga.	086184	1	
11	Bolt, M12 x 35-8.8 Hex Head Full Thread Zinc	F81004-24	1	
12	FITTING, 3/16" GREASE	P04107	2	
13	Roller Assembly, Side Support	015014-1	2	
14	Washer, 17 Flat Zinc	F81058-1	2	
15	Bolt, M16x65-8.8-B Hex Head Full Thread Zinc	F81006-1	1	
16	Nut, M16-8 Hex Nylon Zinc Lock	F81036-2	1	
	Instruction Sheet, Side Support Roller	015109-526	1	

8 **Bed Frame Assembly**
Tie Down Chain Assembly

8.10 Tie Down Chain Assembly

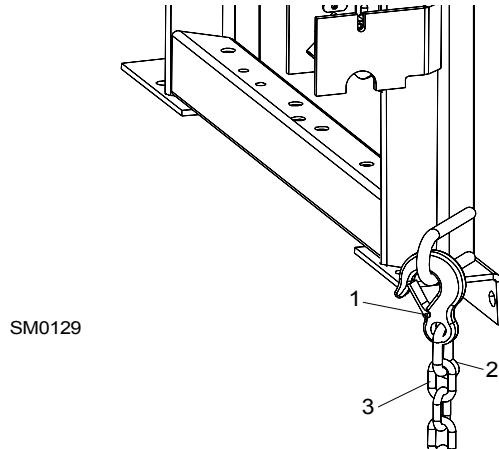

REF	DESCRIPTION (◆ Indicates Parts Available In Assemblies Only)	PART #	QTY.	
	CHAIN ASSEMBLY, TIE DOWN	A04376	1	
1	Hook, 5/8" Safety Chain	P12075	1	◆
2	Cold Shut, 3/8" Plain	P04772-2	1	◆
3	Chain, N-10 x 35 Unplated	R80558	.28 m	◆

8.11 LT70 S/M Saw Head Rest Pin Assembly

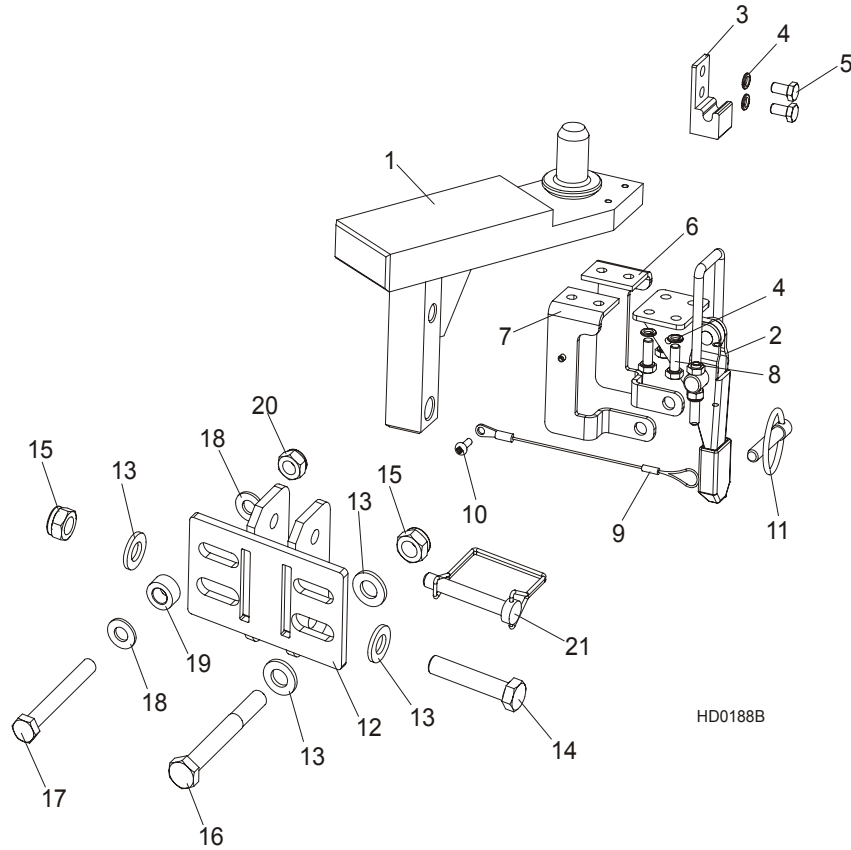

REF	DESCRIPTION (◆ Indicates Parts Available In Assemblies Only)	PART #	QTY.
	SAW HEAD REST PIN W/LATCH CLAMP, LT70S/M	094660	1
1	Pin Weldment, LT70S/M Saw Head Rest	094658-1	1
2	Clamp, GN851.2-320-T4 Latch	094656	1
3	Latch Bracket, GN851.2-320-T4 Zinc-plated	094659-1	1
4	Washer, Z 6.1 Split Lock Zinc	F81053-3	6
5	Bolt, M6x12-8.8 Hex Head Full Thread Zinc	F81001-7	2
6	Bracket, Locking Right	097102-1	1
7	Bracket, Locking Left	097103-1	1
8	Bolt, M6x16-8.8-Fe/Zn5 PN-85/M-82105	F81001-32	4
9	Lanyard, 3/64x6"	016030	1
10	Screw, M4x12 -5,8-B- Fe/Zn5 PN-M/82202	F81011-43	1
11	Pin, 8 BN914(BOSSARD 1364650) Clamp Lock	F81046-2	1
12	BRACKET, LT40 SAW HEAD REST PIN MOUNT PAINTED	092765-1	1
13	WASHER, 13 FLAT ZINC	F81056-1	4
14	BOLT, M12 X 60-8.8 HEX HEAD ZINC	F81004-5	1
15	NUT, M12-8 HEX NYLON ZINC LOCK	F81034-2	2

8**Bed Frame Assembly***LT70 S/M Saw Head Rest Pin Assembly*

16	BOLT, M12x95-8.8 HEX HEAD ZINC	F81004-29	1	
17	BOLT, M10x80-8.8 HEX HEAD ZINC	F81003-50	1	
18	WASHER, 10.5 FLAT ZINC	F81055-1	2	
19	BUSHING, ZINC-PLATED SPACER	090936-1	1	
20	NUT, M10-8-B HEX NYLON ZINC LOCK	F81033-1	1	
21	PIN, 3/8" X 2 1/4" SNAP RETAINER	014151	1	

8.12 Bed Frame Decals

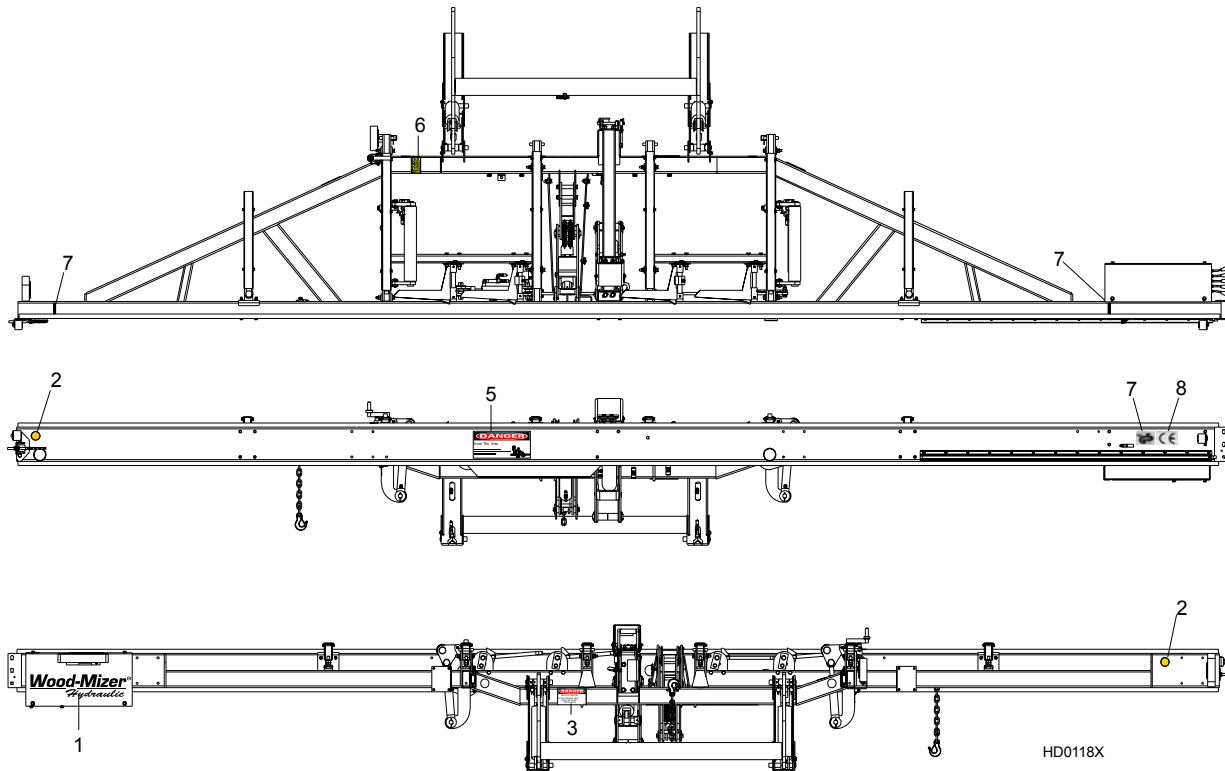

REF	DESCRIPTION (◆ Indicates Parts Available In Assemblies Only)	PART #	QTY.
22	DECAL, AMBER REFLECTIVE 2" ROUND	P07453	2
23	DECAL, KEEP AWAY DANGER	S09851	1
24	DECAL, PINCH POINT DANGER	P10287	1
25	DECAL, SAW HEAD REST CAUTION	S12581	1
26	DECAL, LOG LIMIT STRIP	S12051	2
27	DECAL, GS SAFETY CERTIFICATION, SMALL	P85072	1
28	DECAL, CE CERTIFIED SAWMILL, SMALL	P85070	1

SECTION 9 HYDRAULIC SYSTEM

9.1 Hydraulic Hoses

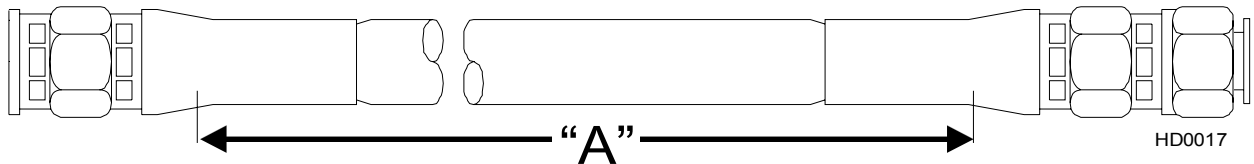

Color Code	LENGTH "A" [m]	Application	Wood-Mizer Part No.
None	0,46	1/4" Hydraulic Pump To Valve	015704
None	0,46	1/4" Hydraulic Pump To Valve	015704
Plain	0,69	3/8" LOG TURNER CYLINDER BASE	014796
Orange	0,53	3/8" LOG TURNER CYLINDER TOP	087775
Yellow	2,66	1/4" FRONT TOE BOARD TOP (LT40S)	087790
	3,81	1/4" FRONT TOE BOARD TOP (LT40M)	087776
Gray	2,66	1/4" FRONT TOE BOARD BASE (LT40S)	087790
	3,81	1/4" FRONT TOE BOARD BASE (LT40M)	087776
Plain	4,21	3/8" SIDE SUPPORT CYLINDER TOP (LT40S)	087791
	4,77	3/8" SIDE SUPPORT CYLINDER TOP (LT40M)	087777
Pink	4,21	3/8" SIDE SUPPORT CYLINDER BASE (LT40S)	087791
	4,77	3/8" SIDE SUPPORT CYLINDER BASE (LT40M)	087777
White	3,68	3/8" CLAMP CYLINDER TOP (LT40S)	087792
	3,98	3/8" CLAMP CYLINDER TOP (LT40M)	087778
Dark Orange	3,27	3/8" CLAMP CYLINDER BASE (LT40S)	087793
	3,83	3/8" CLAMP CYLINDER BASE (LT40M)	087779
Purple	5,18	1/4" REAR TOE BOARD TOP (LT40S)	087794
	5,74	1/4" REAR TOE BOARD TOP (LT40M)	087780
Black	5,18	1/4" REAR TOE BOARD BASE (LT40S)	087794
	5,74	1/4" REAR TOE BOARD BASE (LT40M)	087780
Green	1,58	3/8" LOADING ARM BRANCH TOP	014797
Yellow	1,60	3/8" LOADING ARM BRANCH BASE	014798
Yellow	1,80	3/8" LOADING ARM BRANCH BASE	093329

TABLE 9-1

Blue	4,34	3/8" LOADING ARM CYLINDER TOP (LT40S)	087795
	4,90	3/8" LOADING ARM CYLINDER TOP (LT40M)	087781
Red	4,34	3/8" LOADING ARM CYLINDER BOTTOM (LT40S)	087795
	4,90	3/8" LOADING ARM CYLINDER BOTTOM (LT40M)	087781
Green	4,57	1/4" CLAMP UP (LT40S)	087796
	5,13	1/4" CLAMP UP (LT40M)	087789
Yellow	4,57	1/4" CLAMP DOWN (LT40S)	087796
	5,13	1/4" CLAMP DOWN (LT40M)	087789
White	4,00	1/4" FRONT LOG CLAMP, IN/OUT CYLINDER BOTTOM (A/DH5)	094778
Orange	4,00	1/4" FRONT LOG CLAMP, IN/OUT CYLINDER TOP (A/DH5)	094778
Red	3,80	1/4" FRONT LOG CLAMP, UP/DOWN CYLINDER BOTTOM (A/DH5)	094779
Blue	3,80	1/4" FRONT LOG CLAMP, UP/DOWN CYLINDER TOP (A/DH5)	094779
White	6,00	1/4" REAR LOG CLAMP, IN/OUT CYLINDER BOTTOM (A/DH5)	094780
Orange	6,00	1/4" REAR LOG CLAMP, IN/OUT CYLINDER TOP (A/DH5)	094780
Red	5,60	1/4" REAR LOG CLAMP, UP/DOWN CYLINDER BOTTOM (A/DH5)	094781
Blue	5,60	1/4" REAR LOG CLAMP, UP/DOWN CYLINDER TOP (A/DH5)	094781
Plain	0,40	1/4" HYDRAULIC VALVE TO OIL FLOW CONTROL VALVE (A/DH5)	094782
Plain	0,53	1/4" HYDRAULIC PUMP TO OIL FLOW CONTROL VALVE (A/DH5)	087775
Red	1,50	1/4" FIRST CLAMP, UP/DOWN CYLINDER BOTTOM (A/DH7)	095211
Blue	1,50	1/4" FIRST CLAMP, UP/DOWN CYLINDER TOP (A/DH7)	095211
Red	4,00	1/4" SECOND CLAMP, UP/DOWN CYLINDER BOTTOM (A/DH7)	095212
Blue	4,00	1/4" SECOND CLAMP, UP/DOWN CYLINDER TOP (A/DH7)	095212
Red	8,00	1/4" THIRD CLAMP, UP/DOWN CYLINDER BOTTOM (A/DH7)	095213
Blue	8,00	1/4" THIRD CLAMP, UP/DOWN CYLINDER TOP (A/DH7)	095213
Orange	0,40	1/4" HYDRAULIC VALVE POWER CORD TO CLAMP IN/OUT CYLINDER T-FITTING, BOTTOM (A/DH7)	095214
White	0,40	1/4" HYDRAULIC VALVE POWER CORD TO CLAMP IN/OUT CYLINDER T-FITTING, TOP (A/DH7)	095214
Orange	7,00	1/4" THIRD CLAMP, IN/OUT CYLINDER BOTTOM (A/DH7)	095215
White	7,00	1/4" THIRD CLAMP, IN/OUT CYLINDER TOP (A/DH7)	095215
Orange	2,50	1/4" FIRST/SECOND CLAMP, IN/OUT CYLINDER BOTTOM (A/DH7)	095216
White	2,50	1/4" FIRST/SECOND CLAMP, IN/OUT CYLINDER TOP (A/DH7)	095216
Orange	1,20	1/4" FIRST/SECOND CLAMP, IN/OUT CYLINDER BOTTOM (A/DH7)	095217
White	1,20	1/4" FIRST/SECOND CLAMP, IN/OUT CYLINDER TOP (A/DH7)	095217

TABLE 9-1

9.2 Hydraulic Control Box, LT70 Series AH3

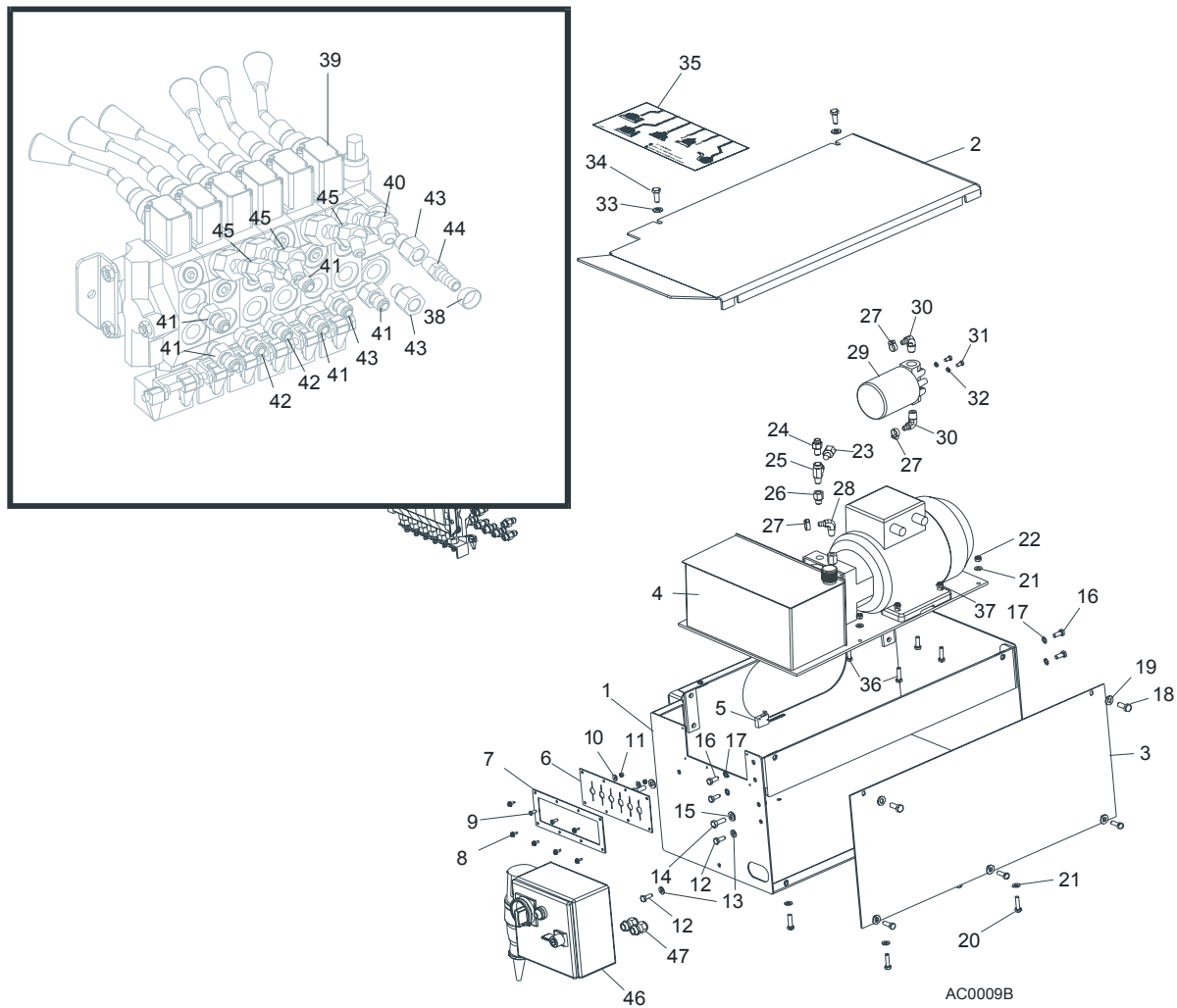

REF	DESCRIPTION (◆ Indicates Parts Available In Assemblies Only)	PART #	QTY.
	BOX, AC SUPER HYDRAULIC (EA20, EA25)	086791	1
	Hole Plug	093544	2
1	BOX WELDMENT, SUPER HYDRAULIC PUMP HOUSING	092243-1	1
2	COVER, AC HYDRAULIC PUMP HOUSING TOP	086485-1	1
3	COVER, AC HYDRAULIC PUMP HOUSING SIDE	086484-1	1
4	FEEDER, 4 KW 14.5 L/MIN. SUPER AC HYDRAULIC WITH PUMP	093459	1
	Pump, AC-4kW Hydraulic	097782	1
	Plate, AC-4kW Hydraulic Connecting	097783	1
	Seal, AC-4kW Hydraulic Complete	097784	1
5	Microswitch, Hydraulic Valve	014765	1

6	SEAL, RUBBER VALVE HANDLE	015079	1	
7	PLATE, VALVE	086519-1	1	
8	SCREW, #10 X 1/2 SLOTTED HEX SELF-TAPPING	F05015-7	6	
9	BOLT, M5X12-5.8 HEX HEAD FULL THREAD ZINC	F81000-5	2	
10	WASHER, 5.5 SPECIAL FLAT ZINC	F81052-3	2	
11	NUT, M5-8 HEX ZINC	F81030-1	2	
12	BOLT, M8 X 20-8.8-B HEX HEAD FULL THREAD ZINC	F81002-4	2	
13	WASHER, 8.4 FLAT ZINC	F81054-1	2	
14	BOLT, 3/8-16X1 HEX HEAD ZINC GRADE 8	F05007-7	2	
15	WASHER, 10.5 FLAT ZINC	F81055-1	2	
16	BOLT, M8 X 20-8.8-B HEX HEAD FULL THREAD ZINC	F81002-4	4	
17	WASHER, 8.4 EXTERNAL STAR LOCK	F81054-3	4	
18	BOLT, M10 X 25-8.8 HEX HEAD FULL THREAD ZINC	F81003-11	4	
19	WASHER, 10.5 FLAT ZINC	F81055-1	4	
20	BOLT, M8 X 25-8.8-B HEX HEAD FULL THREAD ZINC	F81002-5	4	
21	WASHER, 8.4 FLAT ZINC	F81054-1	4	
22	NUT, M8-8-B HEX NYLON ZINC LOCK	F81032-2	4	
23	PLUG, 1/4" NPT BLANK	096221	1	
24	FITTING, 1/4NPT - 1/4NPT MALE	P09143	1	
25	FITTING, C3759X4 MALE RUN TEE	P09141	1	
26	FITTING, #6SAE MALE - 1/4NPT FEMALE	014686	1	
27	CLAMP, 11/16 HOSE	P12739	3	
28	FITTING, #6-6(3/8"NPT) - 3/8" HOSE BARB ELBOW	P12708	1	
29	BRANCH-JOINT, HYDRAULIC WITH FILTER	P22683	1	
30	FITTING, 1/2" NPT - 3/8" HOSE BARB ELBOW	P12707	2	
31	BOLT, 1/4-20 X 1/2" HEX HEAD ZINC GRADE 2	F05005-15	2	
32	WASHER, 6.1 SPLIT LOCK ZINC	F81053-3	2	
33	WASHER, 10.5 FLAT ZINC	F81055-1	2	
34	BOLT, M10 X 25-8.8 HEX HEAD FULL THREAD ZINC	F81003-11	2	
35	DECAL, 1997 SUPER HYDRAULIC CONTROL BOX	015364	1	
36	BOLT, M8 X 30-8.8-B HEX HEAD FULL THREAD ZINC	F81002-7	4	
37	NUT, M8-8-B HEX NYLON ZINC LOCK	F81032-2	4	
38	CLAMP, 11/16" HOSE	P12739	10	
39	VALVE, HYDRAULIC 6-SECTION	086589	1	
	SWITCH, HYDRAULIC VALVE ELECTRIC	024198	1	
40	FITTING, #6 SAE - 3/8" JIC 45° ELBOW	015489	1	
41	FITTING, 3/8" O-RING - 3/8" JIC	014687	5	
42	FITTING, 3/8" O-RING - 1/4" JIC	P26284	3	
43	FITTING, #6 SAE MALE - 1/4" NPT FEMALE	014686	2	
44	FITTING, 1/4" NPT X 3/8" HOSE BARB	014685	1	
45	FITTING, #6 SAE - 1/4" JIC 45° ELBOW	015488	3	
46	BOX, AC HYDRAULIC (SUPER ONLY)	086820	1	
47	GLAND, WIRE (SUPER ONLY)	085388	2	

9.3 Hydraulic Control Box, LT70 Series AH5/7

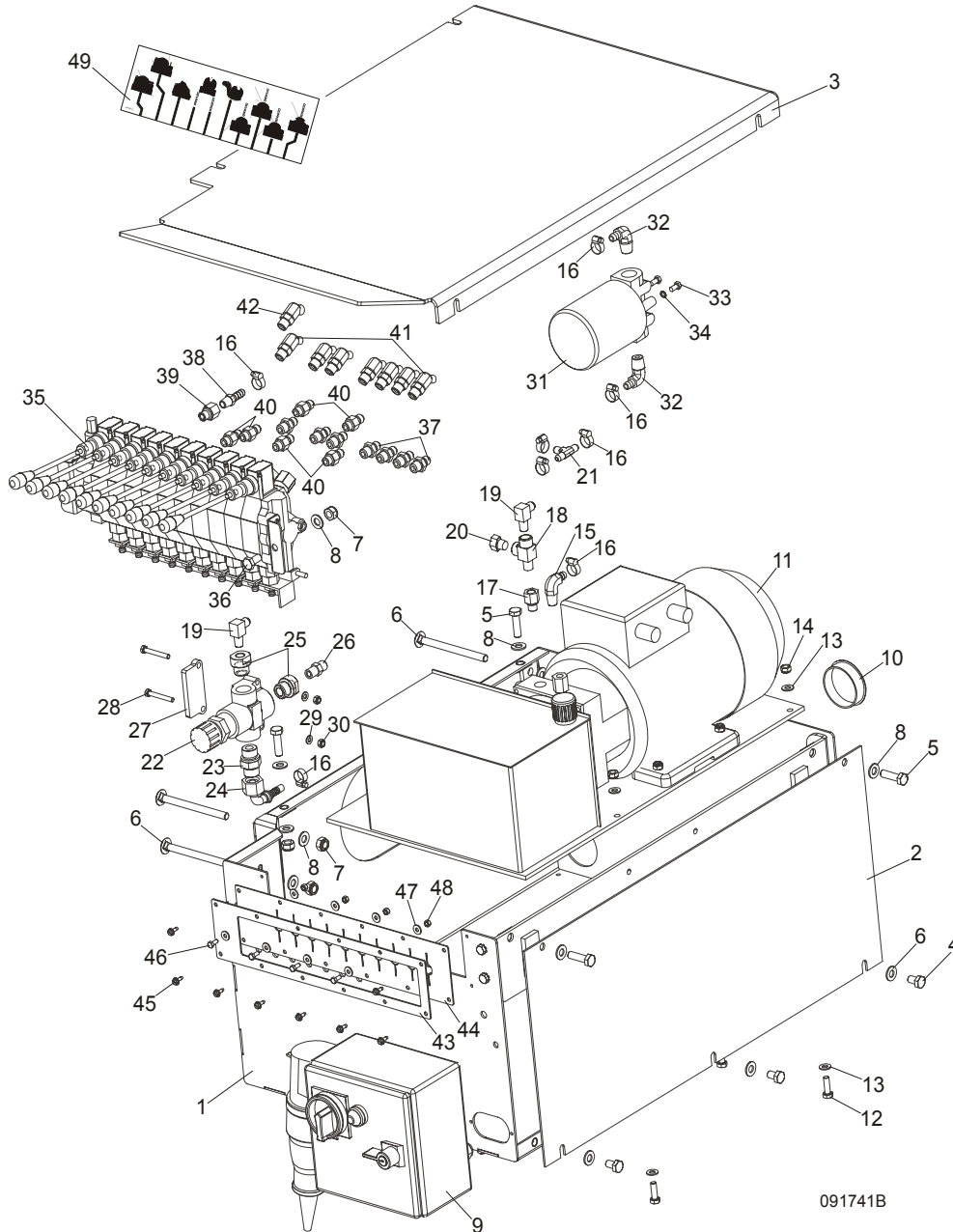

REF	DESCRIPTION (◆ Indicates Parts Available In Assemblies Only)	PART #	QTY.
	BOX ASSEMBLY, LT40 AH5 HYDRAULIC CONTROL	091741	1
1	Box Weldment, Hydraulic Pump Housing	091729-1	1
	Wspornik wzdłużny kompl. skrz. hydr. AC	086518-1	1
	Bolt, M8X20mm, Hex Head,GR 5.8 Zinc	F81002-4	4
	Washer, M8 Crown Lock Zinc	F81054-3	4

2	Cover, AC Hydraulic Pump Housing Side	086484-1	1	
3	Cover, AC/DC Hydraulic Pump Housing Top	091734-1	1	
4	Bolt, M10x16-8.8 Hex Head Full Thread Zinc	F81003-13	3	
5	Bolt, M10x35-8.8 Hex Head Full Thread Zinc	F81003-17	4	
6	Bolt, M10x125 8.8 Carriage Head Zinc	F81003-34	4	
7	Nut, M10-8-B Hex Nylon Zinc Lock	F81033-1	6	
8	Washer, 10.5 Flat Zinc	F81055-1	13	
9	Box, 4kW AC Electric	089799	1	
10	Cap, HSA2790 (63.6 Dia.)	092859	1	
11	Hydraulic Pump W/Motor, 4 kW 14.5 l/min AC	093459	1	
	Pump, AC-4kW Hydraulic	097782	1	
	Plate, AC-4kW Hydraulic Connecting	097783	1	
	Seal, AC-4kW Hydraulic Complete	097784	1	
12	Bolt, M8 x 25-8.8-B Hex Head Full Thread Zinc	F81002-5	4	
13	Washer, 8.4 Flat Zinc	F81054-1	8	
14	Nut, M8-8-B Hex Nylon Zinc Lock	F81032-2	4	
15	Fitting, 3/8" NPT - 3/8" Barb Elbow	P12708	1	
16	Clamp, 11/16 Hose	P12739	8	
17	Fitting, 6 SAE Male - 1/4 NPT Female	014686	1	
18	Fitting, 1/4 NPT x 1/4 JIC Male Run Tee	P09141	1	
19	Fitting, 3/8 JIC - 1/4 NPT 90L	015491	1	
20	Plug, 1/4" NPT Male	090552	1	
21	Fitting, 3/8" Barb Tee	015485	1	
22	Valve, MTKA.VB Oil Flow Control	093794	1	
23	Fitting, VMNW10HS22	094486	1	
24	Fitting, PN10AOL13-90 Elbow	094485	1	
25	Fitting, M22x1.5 / 1/4 - 18 NPT Zinc	093139-1	2	
26	Fitting, 3/8JIC-1/4 NPT Straight	015560	1	
27	Plate, MTKA Control Valve Spacer Zinc-Plated	094477-1	1	
28	Bolt, M6x45-8.8 Hex Head Zinc	F81001-6	2	
29	Washer, 6.4 Flat Zinc	F81053-1	2	
30	Nut, M6-8-B Hex Nylon Zinc Lock	F81031-2	2	
31	Manifold, 1.2" W/Filter	P22683	1	
32	Fitting, 1/2" NPT - 3/8" Barb Elbow	P12707	2	
33	Bolt, 1/4-20 x 1/2" Hex Head Zinc Grade 2	F05005-15	2	
34	Washer, Z6.1 Split Lock Zinc	F81053-3	2	
35	Valve, HDS11/10 6-Section Hydraulic	091344	1	
36	Bolt, M10x20-5.8 Hex Head Full Thread Zinc	F81003-1	2	
37	Fitting, 3/8" O-Ring - 1/4" JIC	P26284	7	
38	Fitting, 1/4" NPT x 3/8" Hose Barb	014685	1	
39	Fitting, #6 SAE Male - 1/4" NPT Female	014686	1	
40	Fitting, 3/8" O-Ring - 3/8" JIC	014687	6	
41	Fitting, #4 SAE - #6 SAE 45° Elbow	015488	7	

9

Hydraulic System*Hydraulic Control Box, LT70 Series AH5/7*

42	Fitting, #6 SAE 45° Elbow	015489	1	
43	Plate, 10-Section Valve Painted	091826-1	1	
44	Guard, 10-Section Valve Rubber	091739	1	
45	Screw, #10-24x1/2 Self-Tapping	F05015-7	8	
46	Bolt, M5x12-5.8 Hex Head Full Thread Zinc	F81000-5	4	
47	Washer, 5.5 Special Flat Zinc-Plated	F81052-3	8	
48	Nut, M5-8 Hex Zinc	F81030-1	4	
49	Decal, AH5 Hydraulic Control Box	094795	1	
	Decal, AH7 Hydraulic Control Box	094970	1	
50	Fitting, 1/4 NPT x 1/4 JIC Male	P09143	1	

9.4 Hydraulic Power Supply Strip

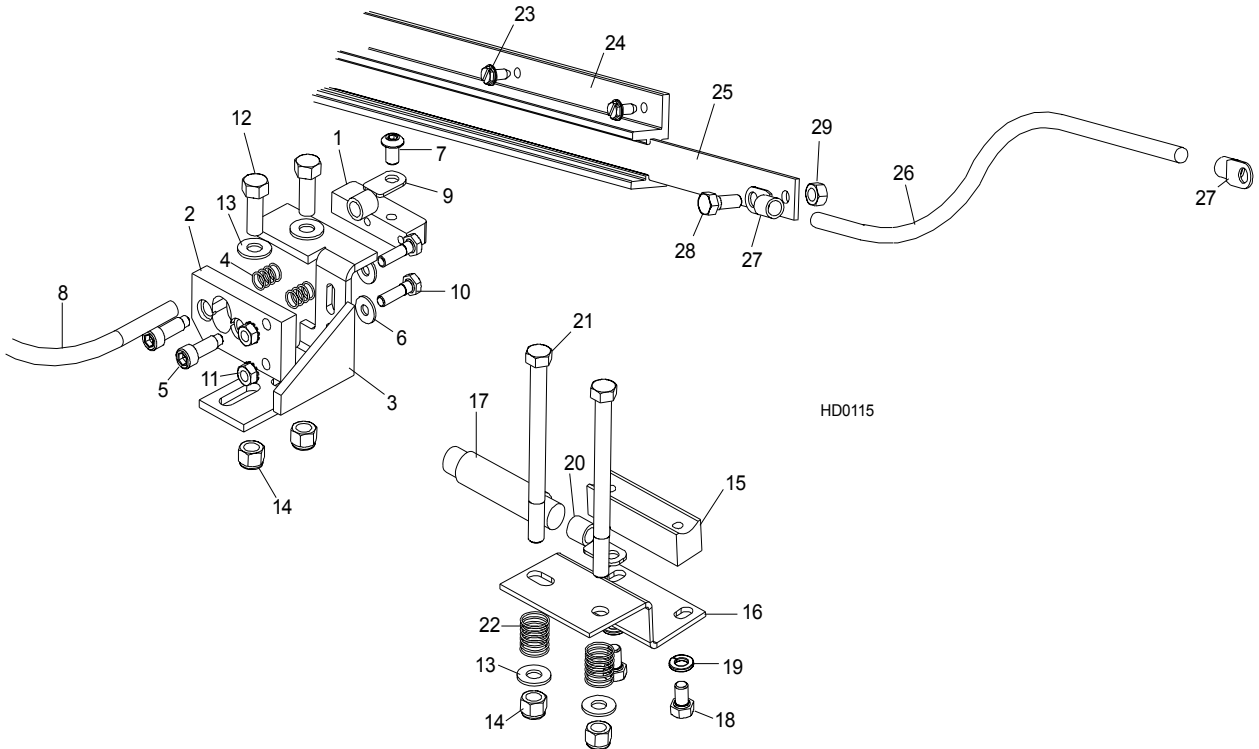

REF	DESCRIPTION (◆ Indicates Parts Available In Assemblies Only)	PART #	QTY.	
	CONTACT KIT, HYDRAULIC 6' POWER SUPPLY	A12042-N	1	
	Contact Hardware Kit	A10073-N	1	◆
	Contact Assembly, Hydraulic Power Supply (Positive)	085968	1	
1	Contact, Hydraulic Power Supply (Positive)	015253	1	
2	Insulator, Positive Contact	S10072	1	
3	Bracket, Positive Contact Mounting	086380-1	1	
4	Spring, Positive Contact	P10077	2	
5	Bolt, 5/16" X 3/4" Shoulder (1/4-20 Thread)	F05006-44	2	
6	Washer, 7.4 Flat Zinc	F81056-11	2	
7	Bolt, 5/16-18 x 1/2" Socket Button Head	F05006-20	1	
	Cable Assy, Hydraulic Positive Contact	015885	1	
8	Cable, #1 Weld	R01948	0.75m	◆
9	Terminal, 35 Ring #2 Gauge	F81066-3	2	
10	Bolt, 1/4-20 X 1" Hex Head Zinc Grade 2	F05005-38	2	
11	Nut, 1/4-20 Self-Locking Hex Zinc	F05010-9	2	
12	Bolt, 3/8-16 X 1" Hex Head Zinc Grade 5	F05007-87	2	

9

Hydraulic System

Hydraulic Power Supply Strip

13	Washer, 10.5 Flat Zinc	F81055-1	4	
14	Nut, 3/8-16 Hex Nylon Lock	F05010-10	4	
	Contact Assembly, Hydraulic Power Supply (Ground)	A10066	1	
15	Contact, Hydraulic Power Supply (Ground)	015264	1	
16	Bracket, Ground Contact Mounting	015265	1	
17	Cable, #1 Weld	R01948	.63m	◆
18	Bolt, 5/16-18 X 1/2" Hex Head Zinc Grade 5	F05006-15	2	
19	Washer, 8.2 Split Lock Zinc	F81054-4	2	
20	Terminal, 35 Ring #2 Gauge	F81066-3	1	
21	Bolt, 3/8-16 X 4 1/2" Hex Head Zinc Grade 2	F05007-35	2	
22	Spring, Ground Contact	P04282	2	
23	Screw, 1/4-20 X 1/2" "23" Type Self-Tapping	F05015-1	14	
24	Housing, 6' Contact Strip	P11976	1	
25	Strip, 6' Contact	S10075	1	◆
26	Cable, #2 Weld	R80583-21		◆
27	Terminal, 35 Ring #2 Gauge	F81066-3		
28	Bolt, 5/16-18 X 3/4" Hex Head Black Nylon	F05006-45	1	
29	Nut, 5/16-18 Hex Black Nylon	F05010-86	1	
	Tube, 5/8" Heat Shrink	R01950-5	m	◆
	Grommet, 5/8" Wire	P04137		

9.5 Hydraulic Log Loader

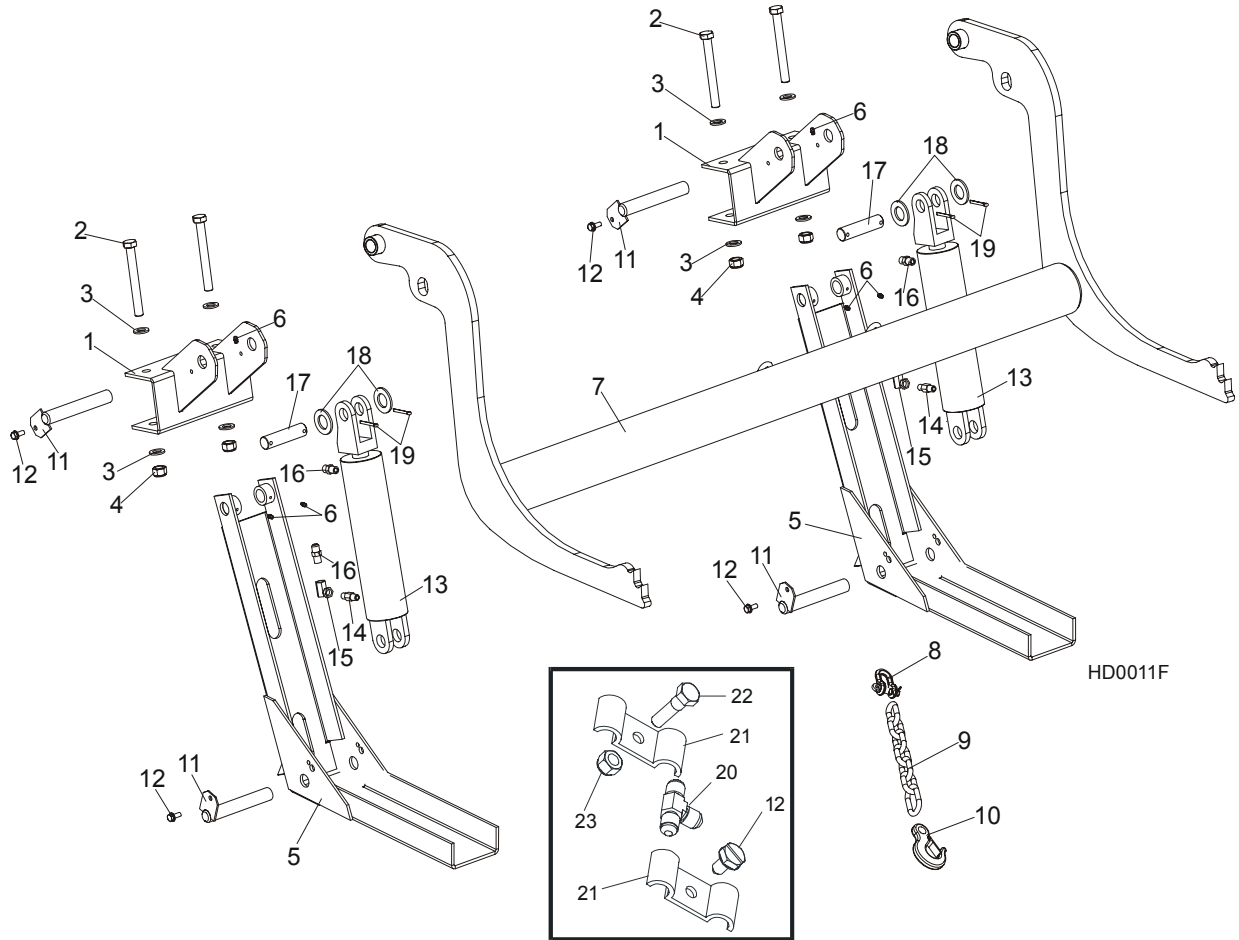

REF	DESCRIPTION (◆ Indicates Parts Available In Assemblies Only)	PART #	QTY.
	LOADER KIT, HYDRAULIC LOG	090527	1
1	Bracket, Hydraulic Log Loader	087938-1	1
2	Bolt, M16x140mm Hex Head Zinc Grade 8.8	F81006-4	4
3	Washer, M16 Flat Zinc	F81058-1	8
4	Nut, M16 Hex Nylon Zinc Lock	F81036-2	4
	Channel, Hydraulic Log Loading Foot Complete	090049	2
5	Channel, Hydraulic Log Loading Foot	090048-1	2
6	Fitting, 3/16x3/16 Straight Grease	P04107	6
	Arm, Hydraulic Log Loading Complete	090044	1
7	Arm, Hydraulic Log Loading	090006-1	1
8	Shackle, M-WL. .63	086540	1
9	Chain, Hydraulic Log Loader Safety	A04376	1

9

Hydraulic System
Hydraulic Log Loader

10	Hook, 5/8 Safety Chain	P12075	1	
11	Pin, Turner Arm	W09446-1	4	
12	Screw, 5/16-18x3/4 Self-Tapping	F05015-30	4	
13	Cylinder Assy, Log Loading Super	015562	2	
14	Fitting, 1/4NPT Velocity Fuse 5.0GPM	015750	2	
15	Fitting, 1/4NPT-1/4JIC Swivel Elbow	P12199	2	
16	Fitting, 3/8JIC-1/4NPT Straight	015560	4	
17	Pin, Cylinder Hydraulic	086979-1	2	
18	Washer, 28 Flat Zinc	F81061-1	4	
19	Pin, 5x40 Cotter	F81043-31	4	
20	Fitting, 3/8 Barb Tee	015485	1	
21	Clamp, 3/8 Hose	016041	2	
22	Bolt, 5/16-18x1 Hex Head Zinc Grade 2	F05006-1	1	
23	Nut, 5/16-18 Nylon Zinc Lock	F05010-58	1	

9.6 Hydraulic Log Turner

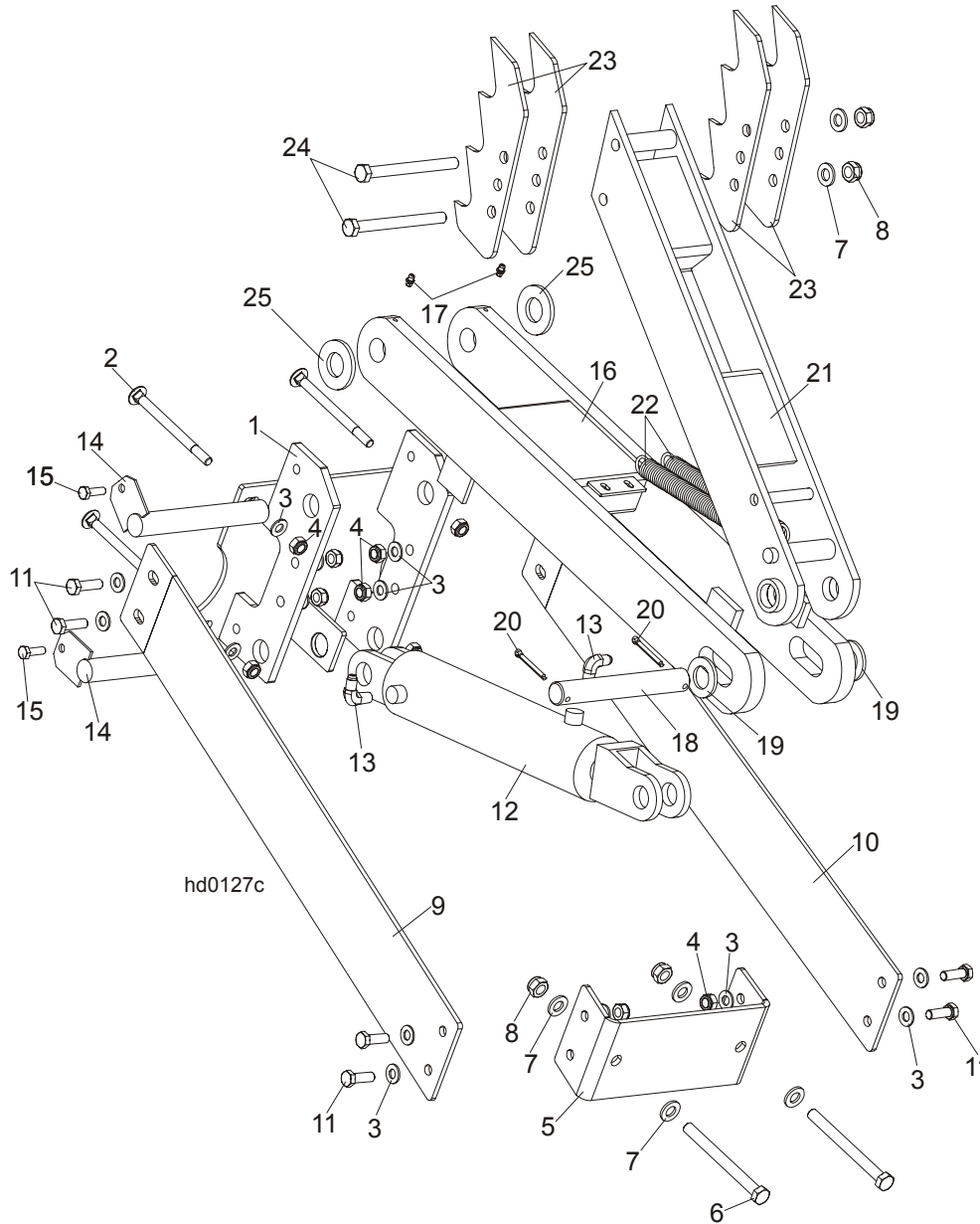

REF	DESCRIPTION (◆ Indicates Parts Available In Assemblies Only)	PART #	QTY.	
	HYDRAULIC LOG TURNER OPTION (S/M TYPE FRAME)	088711	1	
1	Bracket, Hydraulic Log Turner (S/M TYPE FRAME)	088710-1	1	
2	Bolt, M10x120 8.8 Carriage Head Zinc	F81003-33	4	
3	Washer, M10 Flat Zinc	F81055-1	20	
4	Nut, M10 Hex Nylon Zinc Lock	F81033-1	12	

9

Hydraulic System

Hydraulic Log Turner

5	Bracket, Hydraulic Log Turner Front	091046-1	1	
6	Bolt, M12x130-8.8 Hex Head Zinc	F81004-36	2	
7	Washer, M12 Flat Zinc	F81056-1	6	
8	Nut, M12 Hex Nylon Zinc Lock	F81034-2	4	
9	Plate, Hydraulic Log Turner Left	091048-1	1	
10	Plate, Hydraulic Log Turner Right	091049-1	1	
11	Bolt, M10x30mm Hex Head Zinc Grade 5.8	F81003-2	8	
	Cylinder Assy, Log Turner Super	015563	1	
12	Cylinder, CJ-S305-16-63/28/203 Hydraulic	088679	1	
13	Fitting, 1/4NPTx1/4JIC Male Elbow	P09142	2	
14	Pin, Log Turner Mount	088667-1	2	
15	Bolt, M8 x 25mm Hex Head Zinc Grade 5.8	F81002-5	2	
16	Arm, Hydraulic Log Turner Link	088060-1	1	
17	Fitting, M6 Grease	086280	2	
18	Pin, 25 X 180	088664	1	
19	Washer, 25 Zinc	F81061-3	2	
20	Pin, 5x40 Cotter	F81043-31	2	
21	Arm, Hydraulic Log Turner Painted	088067-1	1	
22	Spring, 7/8x8 1/2x1/8 Extension	P09136	2	
23	Claw, Hydraulic Log Turner	088082-1	4	
24	Bolt, M12x130-8.8 Hex Head Zinc	F81004-36	2	
25	Washer, GTM-2644-015	093359	2	

9.7 Hydraulic Log Side Supports (S/M Type Frame)

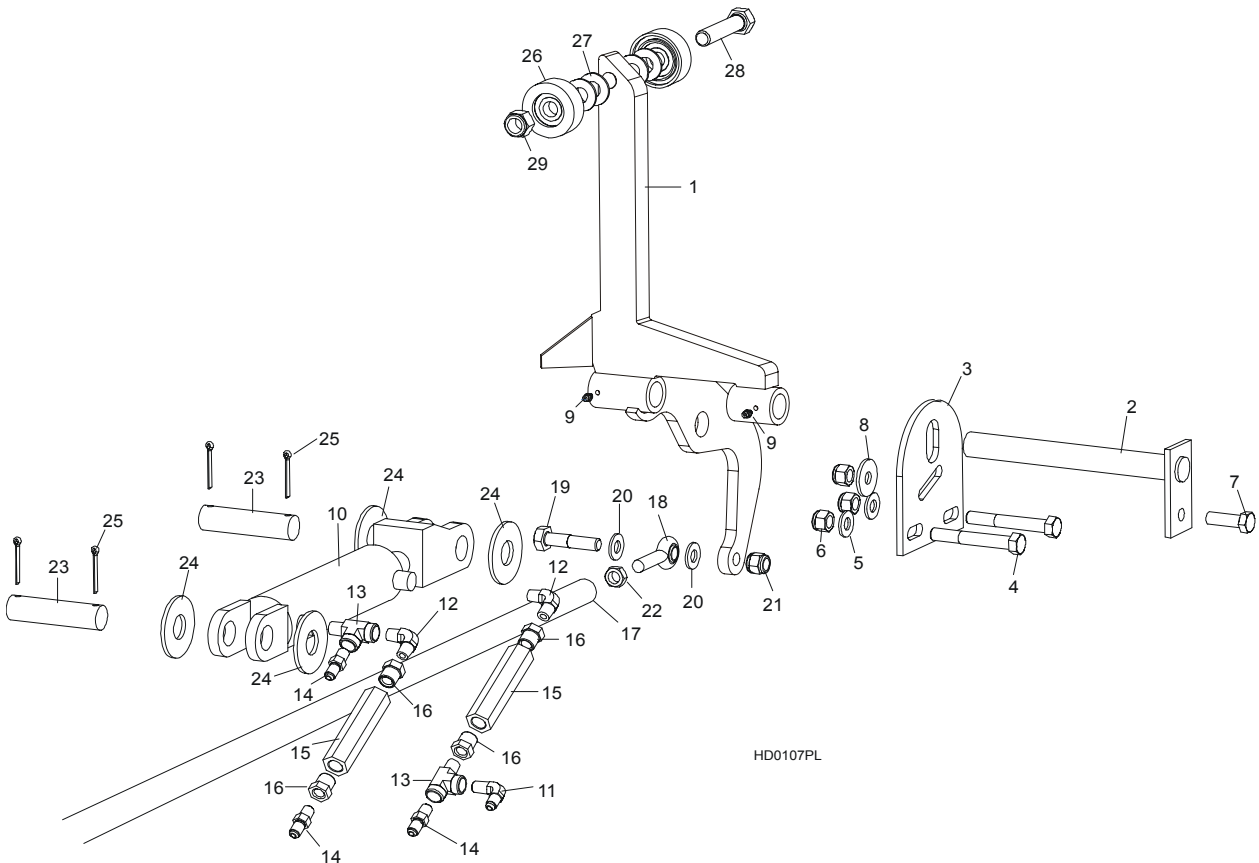

REF	DESCRIPTION (◆ Indicates Parts Available In Assemblies Only)	PART #	QTY.	
	HYDRAULIC LOG SIDE SUPPORTS (S/M TYPE FRAME)	092611	1	
1	SUPPORT, HYDRAULIC LOG SIDE	091653-1	2	
2	PIN, LOG SIDE SUPPORT PIVOT	091549-1	1	
3	PLATE, LOG SIDE SUPPORT END	091591-1	1	
4	BOLT, M12X75-8.8 HEX HEAD ZINC	F81004-21	2	
5	WASHER, 13 FLAT ZINC	F81056-1	2	
6	NUT, M12-8 HEX NYLON ZINC LOCK	F81034-2	3	
7	BOLT, M12 X 35-8.8 HEX HEAD FULL THREAD ZINC	F81004-24	1	
8	WASHER, 15 SPECIAL FLAT ZINC	F81057-3	1	
9	FITTING, 3/16" GREASE	P04107	4	
	CYLINDER ASSY, 2x6 SIDE SUPPORT SUPER	015561	1	
10	Cylinder, CJ-S270-16-50/28/152 Hydraulic	088678	1	◆
	Seal Kit, 6" x 2" Hydraulic Cylinder	P12954	1	
11	Fitting, 3/8JIC-1/4NPT 90L	015491	2	

9

Hydraulic System*Hydraulic Log Side Supports (S/M Type Frame)*

12	Fitting, C3529x4 90° Pipe	P09140	4	
13	Fitting, C3759x4 Male 'T'	P09141	2	
14	Fitting, 3/8JIC-1/4NPT Str	015560	2	
15	Valve, Hydraulic Sequence	015484	2	
16	Fitting, 3/8" NPT - 1/4" NPT Reducer	015490	4	
17	ROD, HYDRAULIC SIDE SUPPORT LINK	089374-1	1	
18	END, RIGHT ROD	087035	1	
	END, LEFT ROD	087036	1	
19	BOLT, M12 X 45-8.8 HEX HEAD ZINC	F81004-32	2	
20	WASHER, 13 FLAT ZINC	F81056-1	4	
21	NUT, M12-8 HEX NYLON ZINC LOCK	F81034-2	2	
22	NUT, M12-04-A RIGHT HEX JAM	F81034-6	1	
	NUT, M12-04-A LEFT HEX JAM	F81034-7	1	
23	PIN, CYLINDER MOUNT	086979-1	2	
24	WASHER, 28 FLAT ZINC	F81061-1	4	
25	PIN, 5 X 40 COTTER	F81043-31	4	
	ROLLER KIT, SIDE SUPPORT	015109	2	
26	Roller Assembly, Side Support	015014-1	2	
27	Washer, 17 Flat Zinc	F81058-1	4	
28	BOLT, M16x65MM, HH F/THRD, GRADE 5.8, ZINC	F81006-1	1	
29	NUT, M16,HEX, NYLON ZINC LOCK	F81036-2	1	
	Instruction Sheet, Side Support Roller	015109-526	1	

9.8 Hydraulic Log Clamp, Right

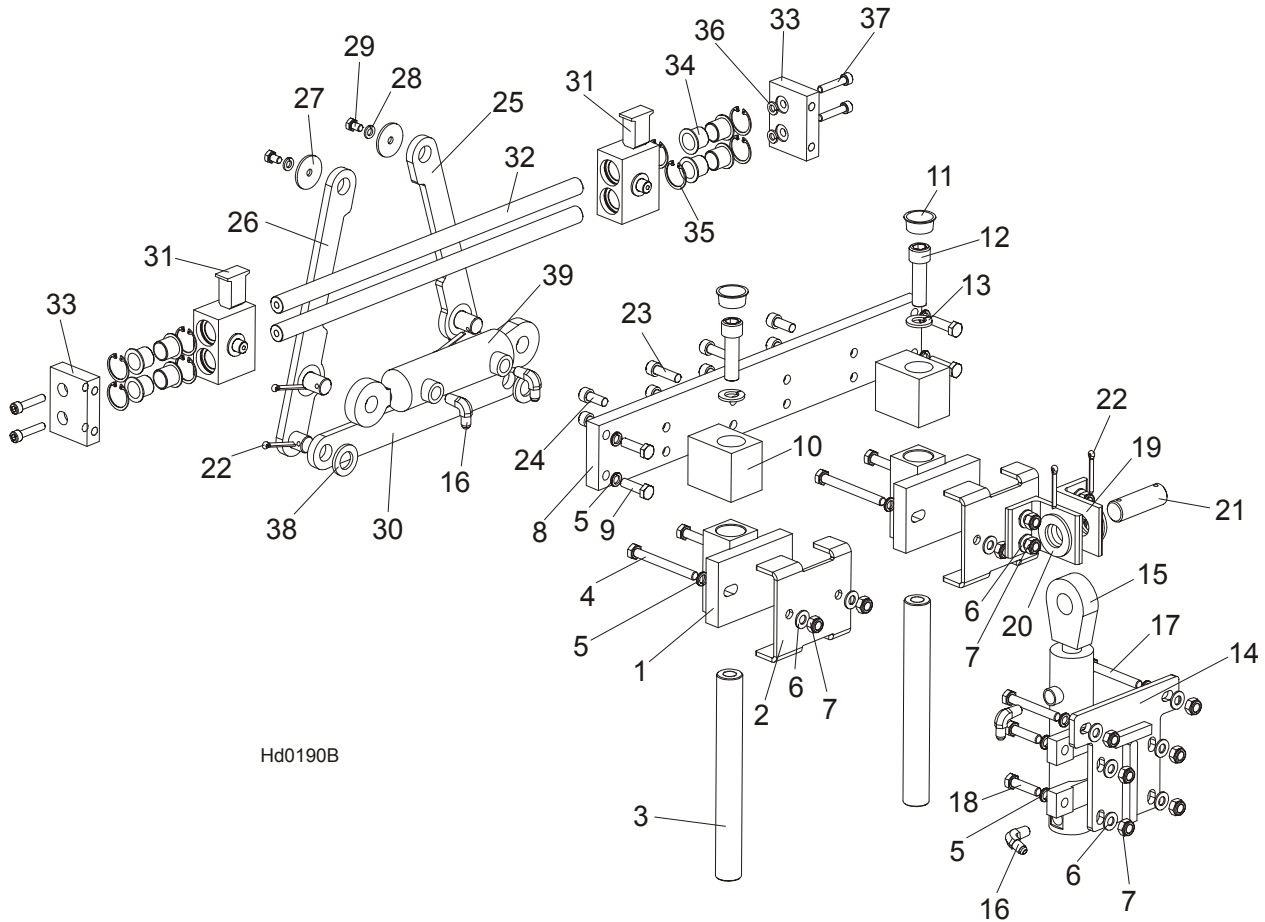

REF	DESCRIPTION (◆ Indicates Parts Available In Assemblies Only)	PART #	QTY.
	RIGHT HYDRAULIC LOG CLAMP ASSEMBLY (FRONT)	094130	1
1	Block Weldment, Log Clamp Up/Down Painted	090545-1	2
2	Bracket, Log Clamp Mount Painted	094098-1	2
3	Pin, Log Clamp Up/Down	088631	2
4	Bolt, M10x95-8.8-B Hex Head Zinc	F81003-71	4
5	Washer, 10.2 Split Lock Zinc	F81055-2	14
6	Washer, 10.5 Flat Zinc	F81055-1	14
7	Nut, M10-8-B Hex Nylon Zinc Lock	F81033-1	14
8	Beam, Log Clamp Main Zinc-plated	094115-1	1
9	Bolt, M10x35-8.8 Hex Head Full Thread Zinc	F81003-17	4
10	Block, Log Clamp Up/Down Painted	094124-1	2
11	Plug, M33 Thread #12428	089839	2

9

Hydraulic System*Hydraulic Log Clamp, Right*

12	Screw, M16x55-8.8 Hex Socket Head Cap Zinc	F81006-18	2	
13	Washer, 16.3 Split Lock Zinc	F81058-2	2	
14	Plate Weldment, Hydraulic Cylinder Mounting Painted	094094-1	1	
15	Cylinder, CJ7F-16/40/22 + UE2-40W Hydraulic	091346	1	
16	Fitting, 90° Male Elbow	P09142	2	
17	Bolt, M10x75-8.8 Hex Head Zinc	F81003-15	2	
18	Bolt, M10x40-8.8 Hex Head Full Thread Zinc	F81003-16	4	
19	Bracket, Hydraulic Cylinder Mounting Painted	094127-1	2	
20	Washer, 28 Flat Zinc	F81061-1	2	
21	Pin, 25x75 Zinc-plated	088659-1	1	
22	Pin, S-Zn 5x40 Cotter Zinc	F81043-31	4	
23	Screw, M10x35 8.8 Hex Socket Head Cap Zinc	F81003-56	4	
24	Screw, M10x25 8.8 Hex Socket Head Cap Zinc	F81003-32	4	
25	Link, Log Clamp In/Out Side Zinc-plated (1)	094097-1	1	
26	Link, Log Clamp In/Out Side Zinc-plated (2)	094099-1	1	
27	Washer, Zinc-plated Spacer	094128-1	1	
28	Washer, 8.2 Split Lock Zinc	F81054-4	2	
29	Bolt, M8x12-8.8 Hex Head Full Thread Zinc	F81002-6	2	
30	Arm, Log Clamp In/Out Zinc-plated	094092-1	1	
31	Jaw Weldment, Log Clamp Zinc-plated	094120-1	2	
32	Rod, Log Clamp Jaw Guide	094116	2	
33	Plate, Locking Zinc-plated	094117-1	2	
34	Bushing, JFM-2023-21 Flanged	094113	8	
35	Ring, W 31 Inside Retaining	F81090-15	8	
36	Washer, 8.2 Split Lock Zinc	F81054-4	4	
37	Screw, M8x40-8.8 Hex Socket Head Cap Zinc	F81002-29	4	
38	Washer, 21 Flat Zinc	F81059-2	2	
39	Cylinder SJ2F-16-40/22/80 Hydraulic	093880	1	

9.9 Hydraulic Log Clamp

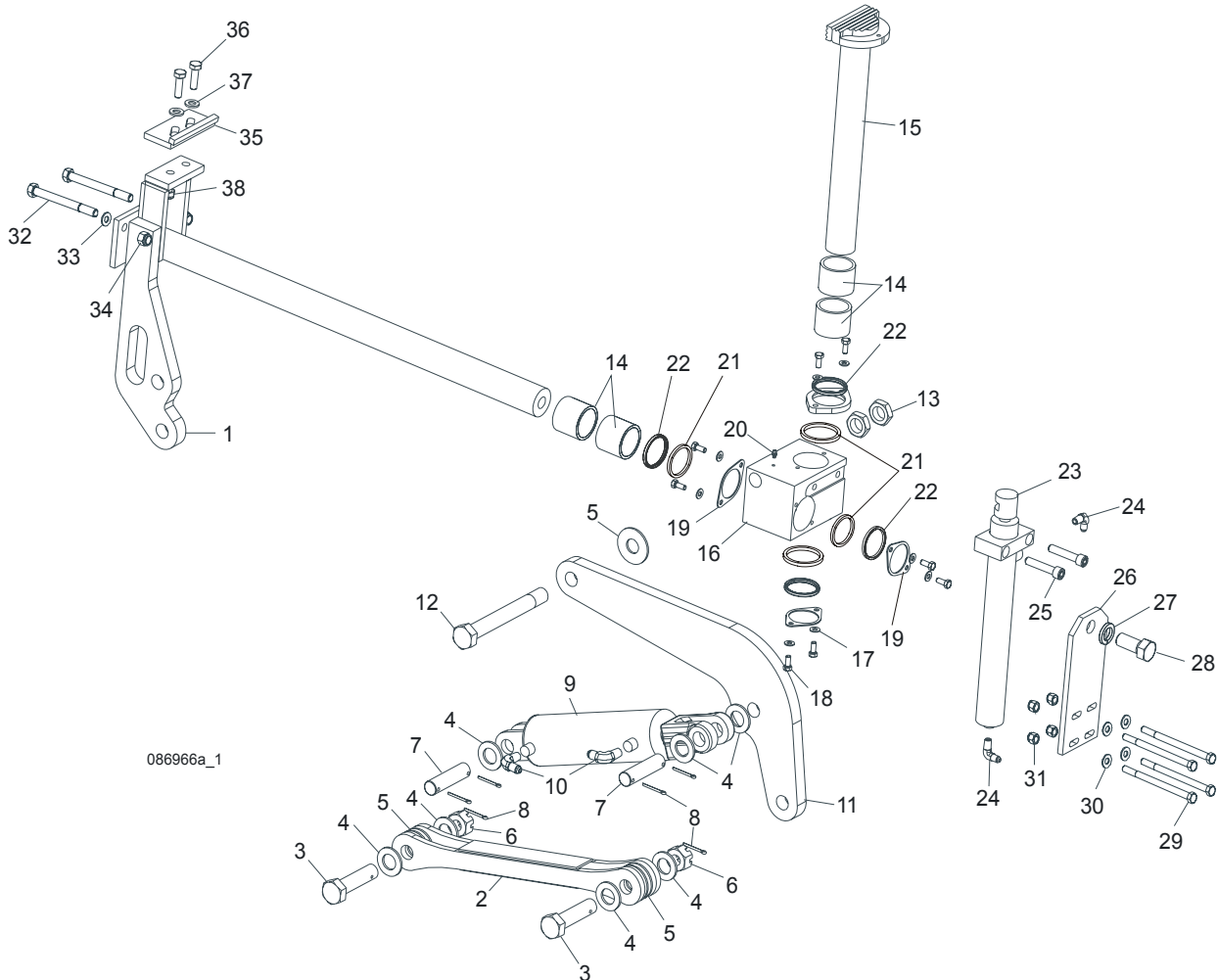

REF	DESCRIPTION (◆ Indicates Parts Available In Assemblies Only)	PART #	QTY.
	LOG CLAMP ASSEMBLY, TWO-PLANE	088658	1
1	Rod Weldment, Log Clamp Slide Painted	086967-1	1
2	Arm Weldment, Hydraulic Clamp Link Painted	086963-1	1
3	Pin, B 24x95/85 Clevis Zinc	F81049-2	1
4	Washer, 25 Flat Zinc	F81061-3	8
5	Washer, 25x63 Zinc-Plated	088585-1	5
6	Nut, M20-8-3 Hex Slotted Castle Zinc	F81037-3	2
7	Pin, Hydraulic Cylinder Zinc-Plated	086979-1	2
8	Pin, 6.3x45 Cotter Zinc	F81045-2	6

9

Hydraulic System*Hydraulic Log Clamp*

9	Cylinder, CJ-S96-16-70/32/178 Hydraulic	088589	1	
10	Fitting, 90° Male Elbow	P09142	2	
11	Arm, Hydraulic Log Clamp Link Painted	086974-1	1	
12	Bolt, M24x217/39 -8.8-B Hex Head Zinc	088586-1	1	
13	Nut, M24 -04-B Hex Thin Zinc	F81039-3	2	
14	Bushing, 5040BS Self-Lubricating	088660	2	
15	Rod Weldment, Log Clamp Vertical Painted	088582-1	1	
16	Block, Log Clamp Painted Steel	088591-1	1	
17	Washer, 8.4 Flat Zinc	F81054-1	8	
18	Bolt, M8x20-8.8-B Hex Head Full Thread Zinc	F81002-4	8	
19	Flange, Clamp Rod Wiper Painted	088887-1	3	
20	Fitting, 3/16" Straight Grease	P04107	1	
21	Spacer, Log Clamp	089324	1	
22	Wiper, ZZ 50x60x7 INCO Log Clamp Rod	088587	1	
23	Cylinder, CJ-S169-16-40/22/254 Hydraulic	088590	1	
24	Fitting, 90° Male Elbow	P09142	2	
25	Screw, M12x55-8.8-B Hex Socket Head Cap Zinc	F81004-23	2	
26	Plate, Log Clamp Mount Painted	086975-1	1	
27	Washer, Z 22.5 Split Lock Zinc	F81059-4	1	
28	Bolt, M22x1.5x40-8.8-B Hex Head Full Thread Zinc	F81009-1	1	
29	Bolt, M10 x 125-8.8 Hex Head Zinc	F81003-18	4	
30	Washer, 10.5 Flat Zinc	F81055-1	4	
31	Nut, M10-8-B Hex Nylon Zinc Lock	F81033-1	4	
32	Bolt, M12 x 140 8.8 Hex Head Zinc	F81004-37	2	
33	Washer, 13 Flat Zinc	F81056-1	2	
34	Nut, M12-8-B Hex Zinc	F81034-1	2	
	STOP ASSEMBLY, LOG CLAMP	K09485	1	
35	Stop Weldment, Hydraulic Log Clamp Painted	086980-1	1	
36	Bolt, M12 x 40 8.8 Hex Head Full Thread Zinc	F81004-4	2	
37	Washer, 13 Flat Zinc	F81056-1	2	
38	Nut, M12-8 Hex Nylon Zinc Lock	F81034-2	2	

9.10 Hydraulic Toe Board

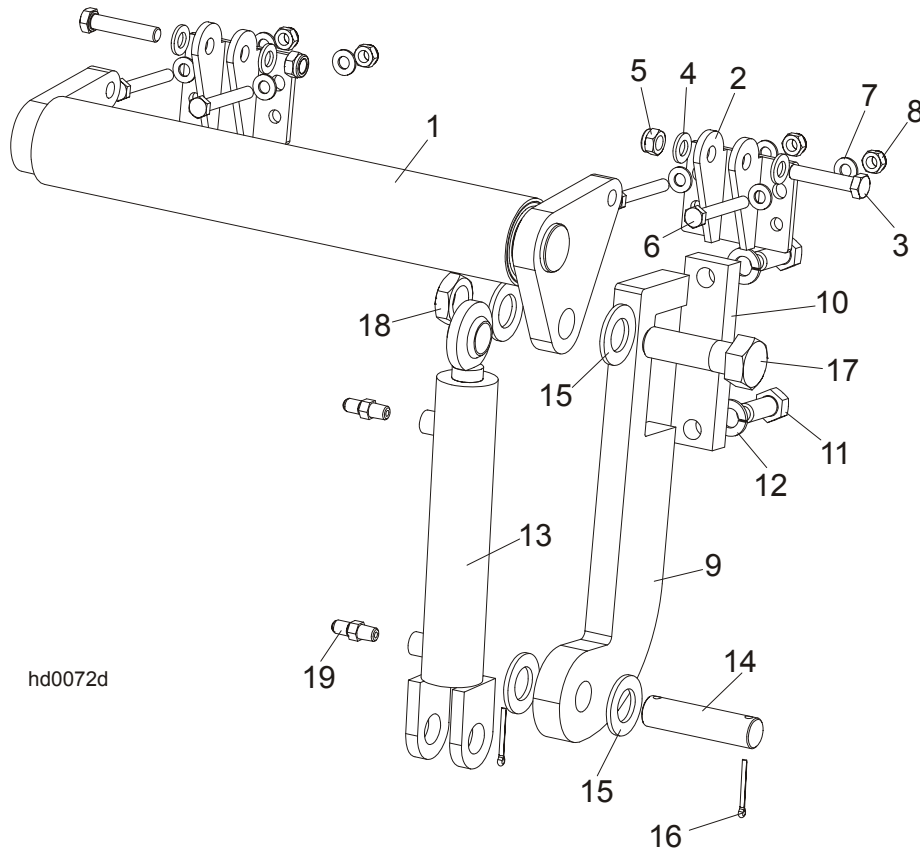

REF	DESCRIPTION (◆ Indicates Parts Available In Assemblies Only)	PART #	QTY.
	HYDRAULIC TOE BOARD - FRONT	092613	1
	HYDRAULIC TOE BOARD - REAR	092634	1
1	Toe Board Weldment, Hydraulic - Front	092612-1	1
1	Toe Board Weldment, Hydraulic - Rear	086253-1	1
2	Bracket, Hydraulic Toe Board	087903-1	2
3	Bolt, M12x60mm Hex Head Zinc Grade 8.8	F81004-5	4
4	Washer, M12 Flat Zinc	F81056-1	8
5	Nut, M12 Hex Nylon Zinc Lock	F81034-2	4
6	Bolt, M10x75-8.8 Hex Head Zinc	F81003-15	8
7	Washer, M10 Flat Zinc	F81055-1	16
8	Nut, M10 Hex Nylon Zinc Lock	F81033-1	8
9	Bracket, Hydraulic Toeboard Mount	087729-1	2
10	Plate, Hydraulic Toeboard Mount	090086-1	2
11	Bolt, M16x40mm Hex Head Full Thread Zinc Grade 5.8	F81006-13	4
12	Washer, 16.3 Split Lock Zinc	F81058-2	4
13	Cylinder, CJ-S170-16-40/25/152 Hydraulic	088681	2

9**Hydraulic System***Hydraulic Toe Board*

14	Pin, Cylinder Mount	086979-1	2	
15	Washer, 28 Flat Zinc	F81061-1	8	
16	Pin, 3/16x1.5 Cotter Zinc	F05012-23	4	
17	Bolt, 1-8x3 1/4 Hex Head Grade 5	F05009-51	2	
18	Nut, 1-14 Hex Jam Unplated	F05010-117	2	
19	Fitting, 1/4NPTx1/4JIC Male	P09143	4	