

Wood-Mizer[®] Sawmill

Parts Manual

LT60AHD
LT70AHD

rev. A1.00
rev. A1.00



Safety is our #1 concern! Read and understand all safety information and instructions before operating, setting up or maintaining this machine.

May 2002

Form #1052

Table of Contents

Section-Page

SECTION 1	GENERAL INFORMATION	1-1
1.1	How To Use The Parts List	1-1
1.2	Sample Assembly	1-1
SECTION 2	BLADE GUIDE ROLLERS & ARM	2-1
2.1	Blade Guide Assembly, Idle Side.....	2-1
2.2	Blade Guide Assembly, Drive Side.....	2-3
2.3	Blade Guide Arm Drive Assembly.....	2-5
SECTION 3	BLADE WHEELS & TENSIONER	3-1
3.2	Idle Blade Wheel Assembly	3-3
3.3	Blade Tensioner Assembly.....	3-5
SECTION 4	SAW HEAD	4-1
4.2	Drive Belt Tensioner	4-2
4.3	Board Return Assembly	4-3
4.4	Water Lube Assembly	4-4
4.5	Saw Head Decals.....	4-5
4.6	Blade Housing Covers.....	4-6
4.7	Sawdust Chute	4-8
SECTION 5	CONTROL & BATTERY BOXES	5-1
5.2	Drum Switches	5-3
5.3	Front Panel Assembly & Harnesses	5-4
5.4	Circuit Breakers.....	5-5
SECTION 6	UP/DOWN SYSTEM	6-1
6.2	Blade Height Scale	6-3
6.3	Up/Down Chain & Sprockets.....	6-5
6.4	Up/Down Drive Assembly	6-7
SECTION 7	FEED SYSTEM & TRACK ROLLERS	7-1
7.1	Upper Track Rollers And Wipers.....	7-1
7.2	Power Feed Assembly	7-3
7.3	Feed Chain/Stop, LT60AHD/LT70AHD	7-4
7.4	Lower Track Rollers.....	7-6

Table of Contents

Section-Page

SECTION 8	BED FRAME ASSEMBLY	8-1
8.1	Bed Rail Assembly, Front And Rear	8-1
8.2	Bed Rail Assembly, Front Middle	8-3
8.3	Bed Rail Assembly, Rear Middle	8-5
8.4	Leg, Stationary	8-6
8.5	Board Return Table Assembly	8-8
8.6	Pivot Bed Rail Assembly.....	8-10
8.7	Log Side Support Assembly (Manual)	8-12
8.8	Tie Down Chain Assembly	8-14
8.9	Saw Head Rest Pin Assembly	8-15
8.10	Bed Frame Decals	8-16
SECTION 9	HYDRAULIC SYSTEM	10-1
9.1	Hydraulic Hoses LT60AHD/70AHD	10-1
9.2	Hydraulic Control Box LT60AHD/70AHD	10-2
9.3	Hydraulic Power Supply Strip.....	10-5
9.4	Hydraulic Log Loader	10-7
9.5	Hydraulic Log Turner	10-9
9.6	Hydraulic Log Side Supports	10-11
9.7	Hydraulic Log Clamp	10-13
9.8	Hydraulic Toe Board	10-15

SECTION 1 GENERAL INFORMATION

1.1 How To Use The Parts List

- Use the index above to locate the assembly that contains the part you need.
- Go to the appropriate section and locate the part in the illustration.
- Use the number pointing to the part to locate the correct part number and description in the table.
- Parts shown indented under another part are included with that part.
- Parts marked with a diamond (◆) are only available in the assembly listed above the part.

See the sample table below. Sample Part #A01111 includes part F02222-2 and subassembly A03333. Subassembly A03333 includes part S04444-4 and subassembly K05555. The diamond (◆) indicates that S04444-4 is not available except in subassembly A03333. Subassembly K05555 includes parts M06666 and F07777-77. The diamond (◆) indicates M06666 is not available except in subassembly K05555.

1.2 Sample Assembly				
REF	DESCRIPTION (◆ Indicates Parts Available In Assemblies Only)	PART #	QTY.	
	Sample Assembly, Complete (Includes All Indented Parts Below)	A01111	1	
1	Sample Part	F02222-22	1	
	Sample Subassembly (Includes All Indented Parts Below)	A03333	1	
2	Sample Part (◆ Indicates Part Is Only Available With A03333)	S04444-4	1	◆
	Sample Subassembly (Includes All Indented Parts Below)	K05555	1	
3	Sample Part (◆ Indicates Part Is Only Available With K05555)	M06666	2	◆
4	Sample Part	F07777-77	1	

To Order Parts:

- From Europe call our European Headquarters and Manufacturing Facility in Kolo, Poland at **+48-63-2610233**. From the continental U.S., call our toll-free Parts hotline at **1-800-448-7881**. Have your customer number, vehicle identification number, and part numbers ready when you call.
- From other international locations, contact the Wood-Mizer distributor in your area for parts.

SECTION 2 BLADE GUIDE ROLLERS & ARM

2.1 Blade Guide Assembly, Idle Side

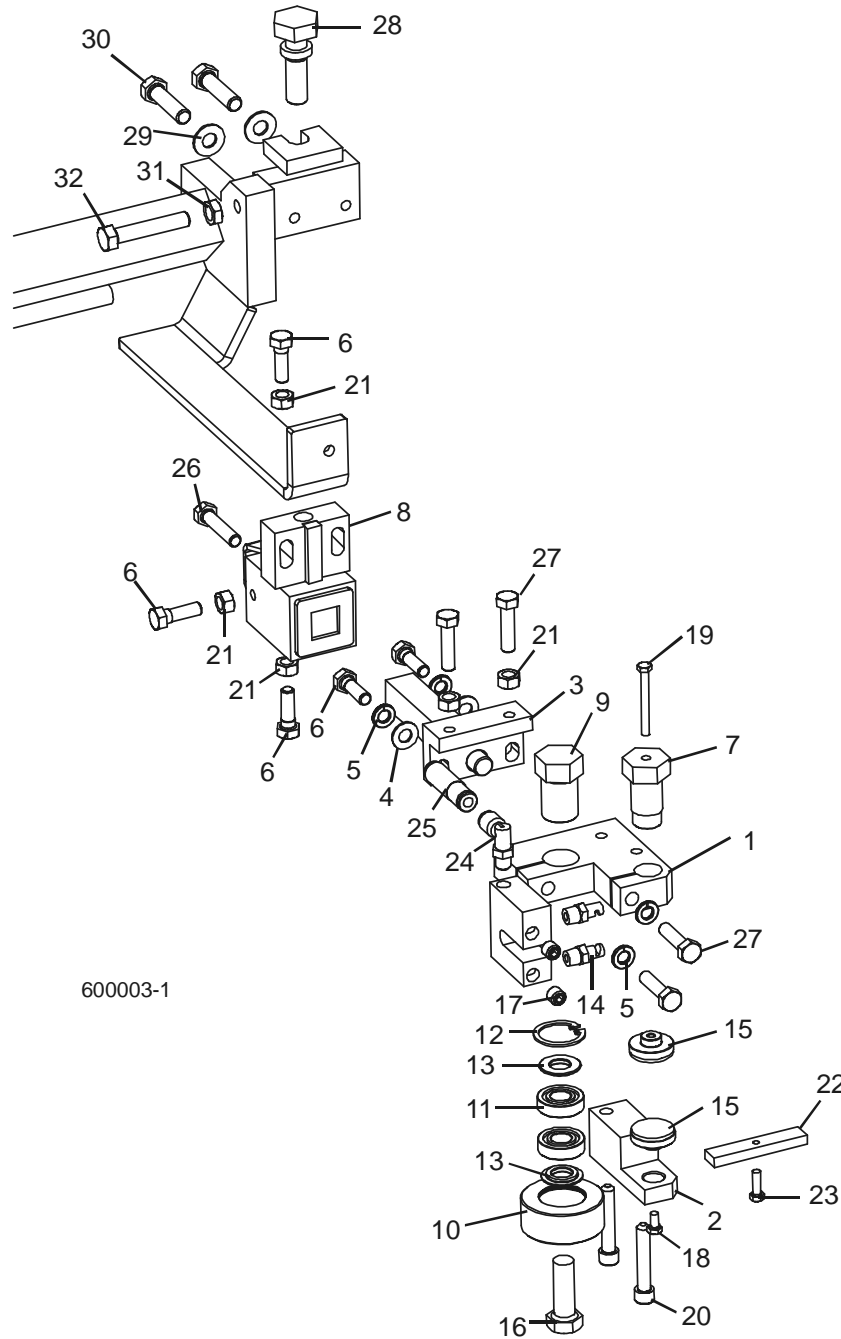

600003-1

Blade Guide Rollers & Arm

Blade Guide Assembly, Idle Side

2

REF	DESCRIPTION (◆ Indicates Parts Available In Assemblies Only)	PART #	QTY.	
	GUIDE ASSEMBLY, IDLE SIDE BLOCK BLADE	035200	1	
1	Block Weldment, Blade Guide Idle Side Mount	035206	1	
2	Block, Lower Blade Guide Mount	035213	1	
3	Shaft Weldment, Blade Guide Mount	035209	1	
4	Washer, 5/16" SAE Flat	F05011-17	2	
5	Washer, 5/16" Split Lock	F05011-13	4	
6	Bolt, 5/16-18 x 1" Hex Head	F05006-88	5	
7	Bolt, Blade Guide Insert Mount	035216	1	
8	Block Weldment, Blade Guide Mount	035219	1	
9	Bolt, Blade Guide Roller Mount	035215	1	
	Roller Assembly, Blade Guide	023977	1	
10	Housing, Blade Guide Roller	017223	1	
11	Bearing, R8-2RS Blade Guide	015975	2	
12	Ring, 1 1/8" IR 3000x112 Retaining	F04254-1	1	
13	Spacer, Blade Guide Roller	018948	2	
14	Fitting, Blade Lube Spray Nozzle	033479	2	
15	Insert Assembly, 1 1/4" Blade Guide	035222	2	
16	Bolt, 1/2-13 x 1 1/2" Hex Head	F05008-4	1	
17	Fitting, 1/8" NPT Socket Pipe Plug	P30127	2	
18	Bolt, #10-32 x 3/8" Hex Head	F05004-171	1	
19	Bolt, #10-32 x 1 3/4" Hex Head	F05004-178	1	
20	Bolt, 5/16-18 x 1 3/4" Socket Head	F05006-65	2	
21	Nut, 5/16-18 Hex	F05010-17	6	
22	Block, Blade Guide Alignment	035799	1	
23	Screw, #10-32 x 5/8 Hex Head Machine	F05004-152	1	
24	Fitting, 1/8" MPT x 1/4" Tube Swivel Elbow	P09736	1	
25	Bolt, 5/16-18 x 1 1/2" Full Thread Hex Head	F05006-119	1	
26	Bolt, 5/16-18 x 1 1/4" Hex Head	F05006-118	4	
27	BOLT, BLADE GUIDE VERTICAL ADJUSTMENT	035656	1	
28	WASHER, 5/16" SAE FLAT	F05011-17	2	
29	WASHER, 5/16" SPLIT LOCK	F05011-13	2	
30	BOLT, 5/16-18 X 1 1/2" FULL THREAD HEX HEAD GRADE 5	F05006-76	2	
31	NUT, 3/8-16 HEX JAM	F05010-29	1	
32	BOLT, 3/8-16 X 2" FULL THREAD HEX HEAD	F05007-16	1	

2 Blade Guide Rollers & Arm

Blade Guide Assembly, Drive Side

2.2 Blade Guide Assembly, Drive Side

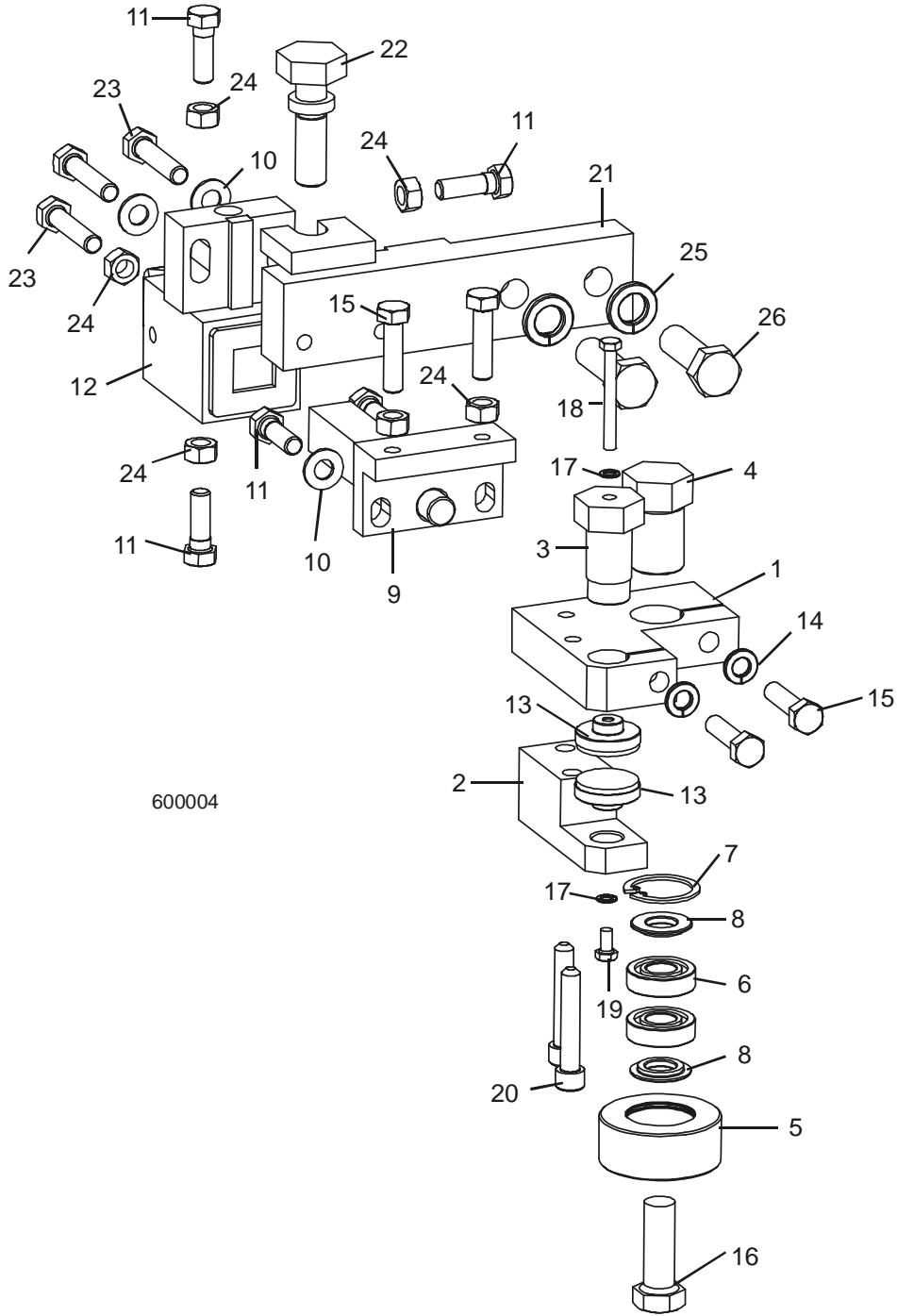

Blade Guide Rollers & Arm

Blade Guide Assembly, Drive Side

2

REF	DESCRIPTION (◆ Indicates Parts Available In Assemblies Only)	PART #	QTY.	
	GUIDE ASSEMBLY, DRIVE SIDE BLADE GUIDE	034291	1	
1	Block, Drive Side Blade Guide Mount	035207	1	
2	Block, Lower Blade Guide Mount	035214	1	
3	Bolt, Blade Guide Insert Mount	035216	1	
4	Bolt, Blade Guide Roller Mount	035215	1	
	Roller Assembly, Blade Guide	023977	1	
5	Housing, Blade Guide Roller	017223	1	◆
6	Bearing, R8-2RS Blade Guide	015975	2	
7	Ring, 1 1/8" IR 3000x112 Retaining	F04254-1	1	
8	Spacer, Blade Guide Roller	018948	2	
9	Shaft Weldment, Blade Guide Mount	035209	1	
10	Washer, 5/16" SAE Flat	F05011-17	2	
11	Bolt, 5/16-18 x 1" Hex Head Stainless Steel	F05006-88	5	
12	Block Weldment, Blade Guide Mount	035219	1	
13	Insert Assembly, 1 1/4" Blade Guide	035222	2	
14	Washer, 5/16" Split Lock	F05011-13	4	
15	Bolt, 5/16-18 x 1 1/4" Hex Head Stainless Steel	F05006-118	4	
16	Bolt, 1/2-13 x 1 1/2" Hex Head	F05008-4	1	
17	Washer, #10 Split Lock	F05011-20	2	
18	Bolt, #10-32 x 1 3/4" Hex Head Stainless Steel	F05004-178	1	
19	Bolt, #10-32 x 3/8" Hex Head Stainless Steel	F05004-171	1	
20	Bolt, 5/16-18 x 1 3/4" Socket Head	F05006-65	2	
21	Bolt, 5/16-18 x 1 1/2" Full Thread Hex Head Stainless Steel	F05006-119	1	
22	Nut, 5/16-18 Hex	F05010-17	6	
23	ARM WELDMENT, DRIVE SIDE BLADE GUIDE	034292	1	
24	BOLT, BLADE GUIDE VERTICAL ADJUSTMENT	035656	1	
25	WASHER, 1/2" SPLIT LOCK	F05011-9	2	
26	BOLT, 1/2-13 X 1 1/2" HEX HEAD GRADE 5	F05008-33	2	
27	WASHER, 5/16" SAE FLAT	F05011-17	2	
28	WASHER, 5/16" SPLIT LOCK	F05011-13	2	
29	BOLT, 5/16-18 X 1 1/2" FULL THREAD HEX HEAD STAINLESS STEEL	F05006-119	2	

2 Blade Guide Rollers & Arm

Blade Guide Arm Drive Assembly

2.3 Blade Guide Arm Drive Assembly

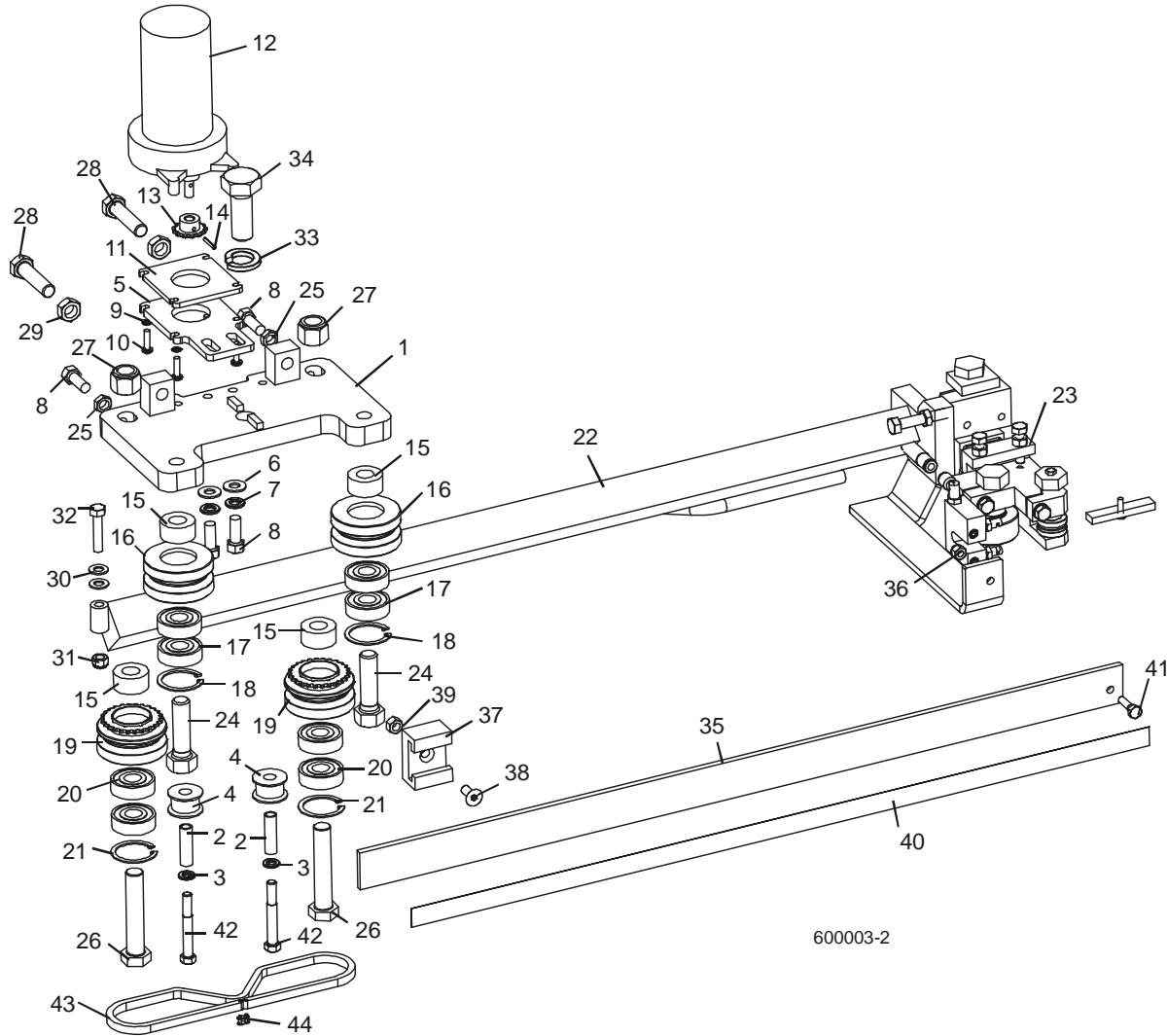

REF	DESCRIPTION (◆ Indicates Parts Available In Assemblies Only)	PART #	QTY.
	ARM ASSEMBLY, IDLE SIDE BLADE GUIDE	034290	1
1	Plate Weldment, Blade Guide Arm	034286	1
2	Spacer, .322" x .44" x 1 1/2"	S09996	2
3	Washer, 5/16" Split Lock	F05011-13	2
4	Roller, Blade Guide Drive	S09999	2
5	Plate, Blade Guide Motor Mount	033803	1
6	Washer, 3/8" SAE Flat	F05011-3	2
7	Washer, 3/8" Split Lock	F05011-4	2
8	Bolt, 3/8-16 x 1" Hex Head	F05007-7	4
9	Washer, #10 Split Lock	F05011-20	4
10	Screw, #10-32 x 3/4" Phillips Head Machine	F05004-38	4

11	Plate, Blade Guide Motor Mount Spacer	033805	1	
12	Motor, 1/30 HP 62RPM 12VDC 53:1 Gear	P09698-1	1	
13	Sprocket, 25B13 x .3130	P09970	1	
14	Pin, 1/8" x 3/4" Roll	F05012-6	1	
15	Spacer, Blade Guide Arm V-Roller	033913	4	
	Roller Assembly, Blade Guide Arm V Idle	042543	2	
16	Housing, 2 1/2" V-Groove	042536	1	
17	Bearing, 5/8" x 1.7548" x .4724"	P06030-1	2	
18	Ring, 1.575" ID Beveled 5002-156 Retaining	F04254-8	1	
	Roller Assembly, Blade Guide Arm V Drive	042542	2	
19	Housing, 2 1/2" V-Groove w/Sprocket	042541	1	
20	Bearing, 5/8" x 1.7548" x .4724"	P06030-1	2	
21	Ring, 1.575" ID Beveled 5002-156 Retaining	F04254-8	1	
22	Arm Weldment, Blade Guide	034289	1	
23	Blade Guide Parts (<i>See Section 2.1</i>)			
24	Bolt, 5/8-18 x 2 1/4" Hex Head Grade 5	F05009-80	2	
25	Nut, 3/8-16 Hex Jam	F05010-29	2	
26	Bolt, 5/8-18 x 3 1/4" Hex Head Grade 5	F05009-98	2	
27	Nut, 5/8-18 Hex Nylon Lock	F05010-71	2	
28	Bolt, 1/2-20 x 2" Hex Head Full Thread	F05008-126	2	
29	Nut, 1/2-20 Hex Jam	F05010-16	2	
30	Washer, 5/16" SAE Flat	F05011-17	2	
31	Nut, 5/16-18 Hex Nylon Lock	F05010-58	1	
32	Bolt, 5/16-18 x 1 1/2" Hex Head Grade 5	F05008-96	1	
33	Washer, 3/4" Split Lock	F05011-6	1	
34	Bolt, 3/4-16 x 2" Full Thread Hex Head	F05013-1	1	
35	Guard, Blade Guide Arm	014955	1	
36	Nut, 1/4-20 Hex Nylon Lock	F05010-69	1	
37	Bracket, Blade Guide Arm Guide	014882	1	
38	Bolt, 5/16-18 x 3/4" Flat Head Socket	F05006-95	1	
39	Nut, 5/16-18 Hex Lock	F05010-6	1	
40	Decal, Blade Guide Arm Warning Stripe	015849	1	
41	Screw, 1/4-20 x 1" Hex Head	F05006-10	2	
42	Bolt, 5/16-18 x 2 1/2" Hex Head	F05006-10	2	
43	Chain, #25 x 92 Pitches	042443	1	
44	Link, #25 Master	P09983	2	

SECTION 3 BLADE WHEELS & TENSIONER

3.1 Blade Drive Assembly

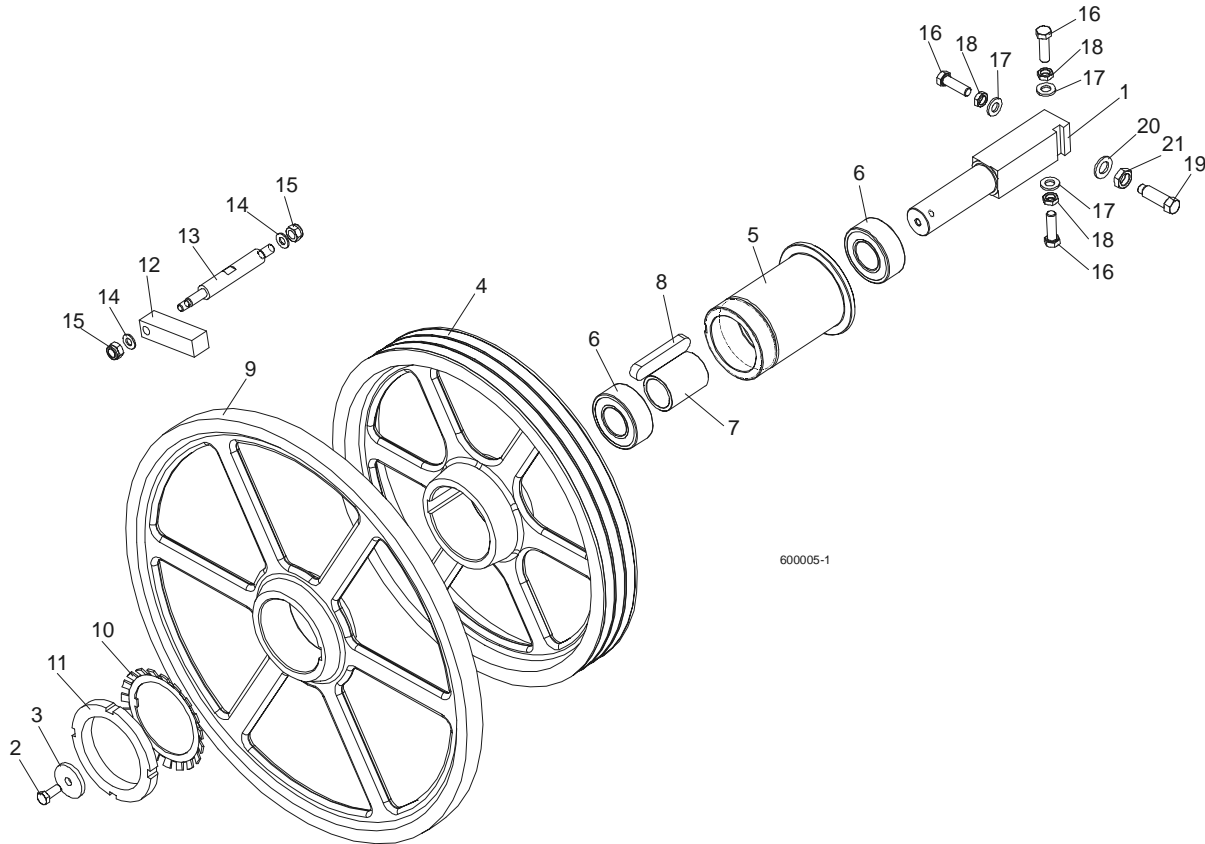

REF	DESCRIPTION (◆ Indicates Parts Available In Assemblies Only)	PART #	QTY.
1	SHAFT, BLADE DRIVE WHEEL	088475	1
2	BOLT, M10x25 8.8 HEX HEAD FULL THREAD	F81003-31	1
3	WASHER, BLADE DRIVE WHEEL	088956-1	1
	PULLEY ASSEMBLY, BLADE DRIVE	088561	1
4	Pulley, 3-Groove 484 mm Diameter	089457-1	1
5	Bushing, Blade Drive Wheel	088476	1
6	Bearing, 3208.2rsr.tvh (FAG) Rolling	088449	2
7	Spacer, Drive Bearing	088478	1
8	Key, A20x12x100 Parallel	088477	1
9	WHEEL, BLADE DRIVE	088420-1	1
10	WASHER, MB21 (FAG) LOCK	088451	1
11	NUT, KM21(M105X2) (FAG) LOCK	088450	1
12	BAR, WHEEL SCRAPER	088781	1
13	SHAFT, WHEEL SCRAPER	088780-1	1

3 Blade Wheels & Tensioner

Blade Drive Assembly

14	WASHER, 10.5 ZINC FLAT	F81055-1	2	
15	NUT, M12-8 HEX NYLON ZINC LOCK	F81034-2	2	
16	BOLT, M12X1.25X40 HEX HEAD	F81004-42	3	
17	WASHER, 13 FLAT ZINC	F81056-1	3	
18	NUT, M12X1.25 8.8 THIN ZINC	F81034-5	3	
19	SCREW, M16X1.5X50-33H HEX HEAD FULL DOG POINT SET ZINC	F81006-14	1	
20	WASHER, 17 ZINC FLAT	F81058-1	1	
21	NUT, M16x1.5-08-B ZINC THIN	F81036-6		

3**Blade Wheels & Tensioner***Idle Blade Wheel Assembly*

14	BOLT, M8X25-8.8-B HEX HEAD FULL THREAD ZINC	F81002-5	1	
15	WASHER, 8.4 ZINC FLAT	F81054-1	1	
16	NUT, M8-8-B HEX NYLON ZINC LOCK	F81032-2	1	
	WHEEL ASSEMBLY, IDLE SIDE	088764	1	
17	Wheel, Blade Idle Side	088419-1	1	
18	Bearing, 3309B.2RSR.TVH-P66 FAG	086428	1	
19	Ring, W100 Spring Retaining	F81090-10	2	
20	BOLT, M10X25 8.8 HEX HEAD FULL THREAD	F81003-31	1	
21	WASHER, IDLE BLADE WHEEL RETAINING	088957-1	1	
22	SCRAPER, IDLE BLADE WHEEL	088781	1	
23	SHAFT, SHORT ZINC WHEEL SCRAPER	088779-1	1	
24	WASHER, 10.5 ZINC FLAT	F81055-1	2	
25	NUT, M12-8 HEX NYLON ZINC LOCK	F81034-2	2	

3.3 Blade Tensioner Assembly

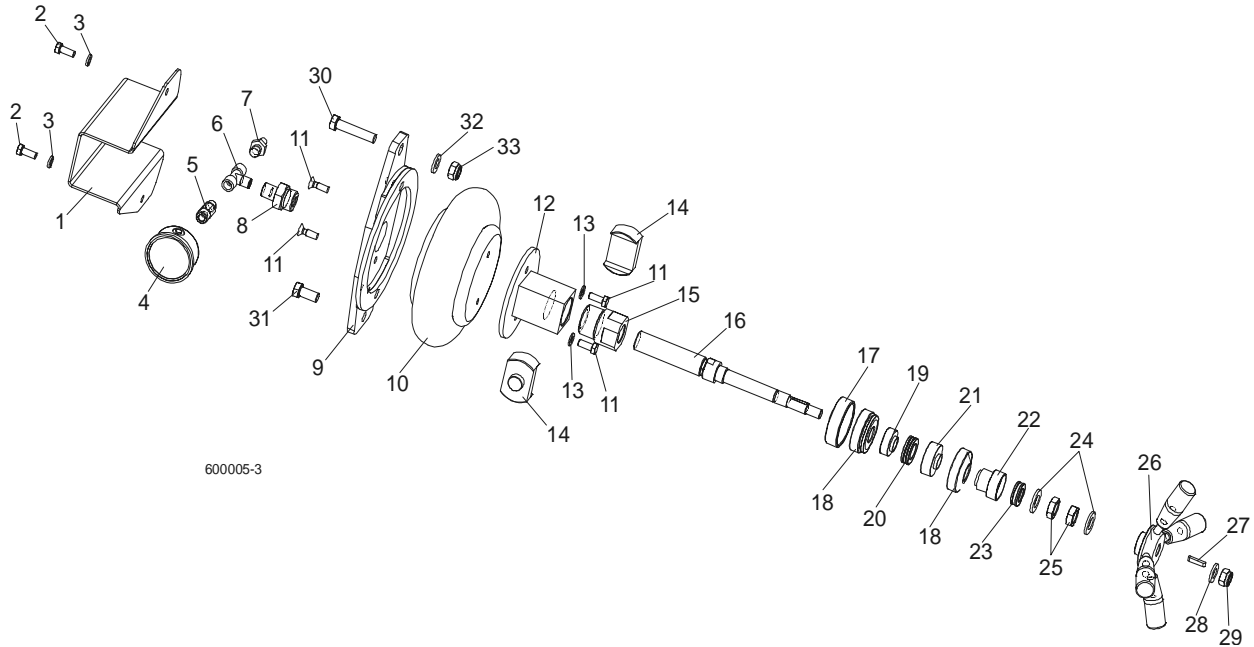

REF	DESCRIPTION (◆ Indicates Parts Available In Assemblies Only)	PART #	QTY.
	BLADE TENSIONER, COMPLETE	088790	1
1	Guard, Air Pressure Gauge	088924	1
2	Bolt, M8x20-8.8-B Hex Head Full Thread Zinc	F81002-4	2
3	Washer 8.2 Zinc Split	F81054-4	2
4	Gauge, M63T-2,5/20G G 1/8 0-0,6 MPa/PSI Air Pressure	088568	1
5	Nipple, 1/8" Thread x 1/4" Thread	088571	1
6	Fitting, PO 2301 002 2 Tee Connector	088573	1
7	Fitting, 1/4" Thread 390 004 004 0 (REXROTH) Air Tank Valve	088575	1
8	Nipple, 1/4 Thread x 3/4 Thread	088572	1
9	Bracket, Air Bag Mount	088798-1	1
10	Bag, POJ 192 308 100 0 Air	088576	1
11	Screw, M8x25 Cross Recessed Countersunk Head Zinc	F81002-51	4
12	Tube Weldment, Tensioner Nut	088795-1	1
13	Washer, 8.4 Zinc Flat	F81054-1	2
14	Plate, Tube Guide	089433	1
15	Nut, Blade Tensioner	088794	1
16	Bolt, Blade Tensioner Special	088793-1	1
17	Seat, Spherical Bearing Threaded	088803-1	1
18	Bearing, GE20 AW (ELGES) Spherical Plain Thrust	089430	2
19	Bushing, Bearing Spacer	088791	1

3**Blade Wheels & Tensioner***Blade Tensioner Assembly*

20	Bearing, 51104 Thrust Ball	088989	1	
21	Seat, 51104 Thrust Bearing	089439	1	
22	Seat, 51103 Thrust Bearing	089440-1	1	
23	Bearing, 51103 FLT Thrust Ball	086675	1	
24	Washer, 17 Zinc Flat	F81058-1	2	
25	Nut, M16x1,5-08-B Zinc Thin	F81036-6	2	
26	Handle, Blade Tensioner Complete	089431	1	
27	Key, A5x5x25 Parallel	089432	1	
28	Washer, 13 Zinc Flat	F81056-1	1	
29	Nut, M12-8 Hex Nylon Zinc Lock	F81034-2	1	
30	BOLT, M12x55-8.8 HEX HEAD ZINC	F81004-12	1	
31	BOLT, M12x25-8.8 HEX HEAD FULL THREAD ZINC	F81004-31	1	
32	WASHER,13 ZINC FLAT	F81056-1	1	
33	NUT, M12-8 HEX NYLON ZINC LOCK	F81034-2	1	

SECTION 4 SAW HEAD

4.1 Middle Throat Screw

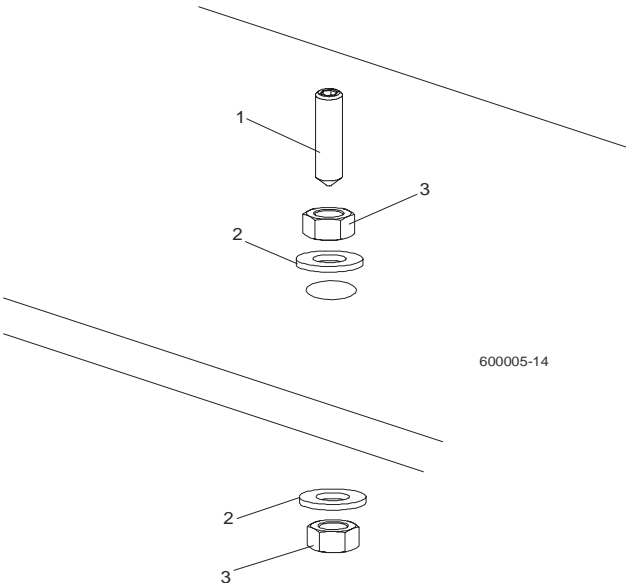

REF	DESCRIPTION (◆ Indicates Parts Available In Assemblies Only)	PART #	QTY.	
1	SCREW, M10X40-45H HEX SOCKET SET CONE POINT ZINC	F81003-61	1	
2	WASHER, 10.5 ZINC FLAT	F81055-1	2	
3	NUT, M10-8-B ZINC HEX	F81033-3	2	

4 Saw Head

Drive Belt Tensioner

4.2 Drive Belt Tensioner

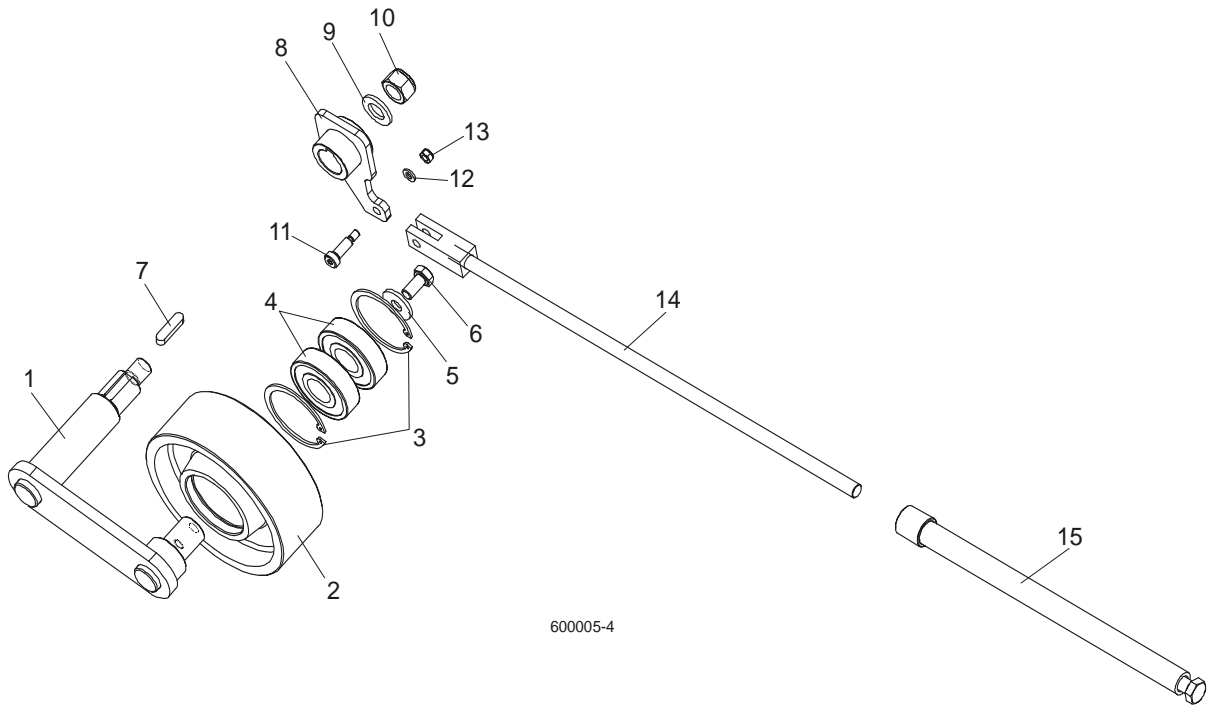

REF	DESCRIPTION (◆ Indicates Parts Available In Assemblies Only)	PART #	QTY.
	TENSIONER ASSEMBLY, DRIVE BELT	088786	1
1	Pivot Weldment, Drive Belt Tensioner	088810-1	1
2	Wheel, Belt Tension	088814	1
3	Ring, 62 mm Inside Spring Retaining	F81090-1	2
4	Bearing, 6305 2RS NSK	P08066	2
5	Washer, 11 Zinc Flat Special	088787-1	1
6	Bolt, M10x20-5.8 Hex Head Full Thread Zinc	F81003-1	1
7	Key, A8X7X32 Parallel	088564	1
8	Arm Weldment, Drive Belt Tensioner	088807-1	1
9	Washer, 17 Zinc Flat	F81058-1	1
10	Nut, M16-5.8 Zinc Hex	F81036-1	1
11	Bolt, 8/M6X20 12.9 ISO 7379 BOSSARD	F81001-25	1
12	Washer 6.4 Zinc Flat	F81053-1	1
13	Nut, M6-8-B Hex Nylon Zinc Lock	F81031-2	1
14	Rod Weldment, Threaded	088789-1	1
15	Tube Weldment, Threaded	088782-1	1

4.3 Board Return Assembly

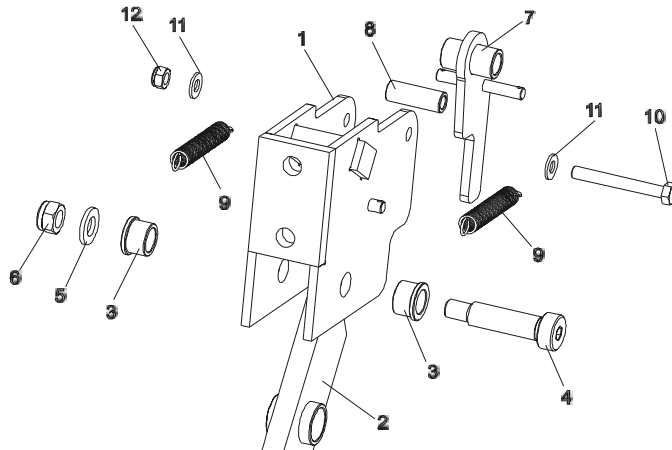
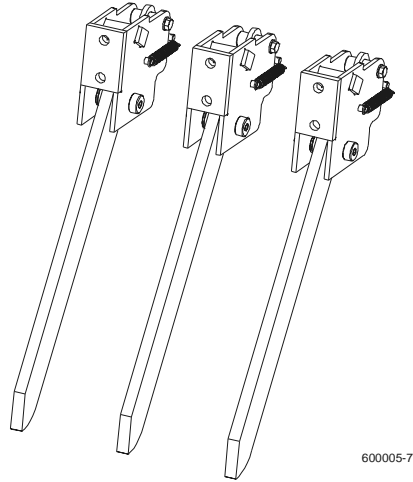

REF	DESCRIPTION (◆ Indicates Parts Available In Assemblies Only)	PART #	QTY.
	BOARD RETURN ASSEMBLY	090120	3
1	MOUNT WELDMENT, BOARD RETURN ARM	090109-1	3
2	ARM, BOARD RETURN	090112-1	3
3	Bushing, Bronze	086676	6
4	BOLT, 16/M12X50-12.9 ISO7379-BOSSARD SOCKET HEAD	F81004-25	3
5	WASHER, 13 ZINC FLAT	F81056-1	3
6	NUT, M12-8 HEX NYLON ZINC LOCK	F81034-2	6
7	LATCH WELDMENT, BOARD RETURN ARM	090118-1	3
8	SPACER, ZINC	090115-1	3
9	SPRING, 1/2 X 2 1/4 X .06 EXTENSION	014817	6
10	BOLT, M8 X 65-5.8 HEX HEAD ZINC	F81002-3	3
11	WASHER, 8.4 ZINC FLAT	F81054-1	6
12	NUT, M8-8-B HEX NYLON ZINC LOCK	F81032-2	3

4 Saw Head

Water Lube Assembly

4.4 Water Lube Assembly

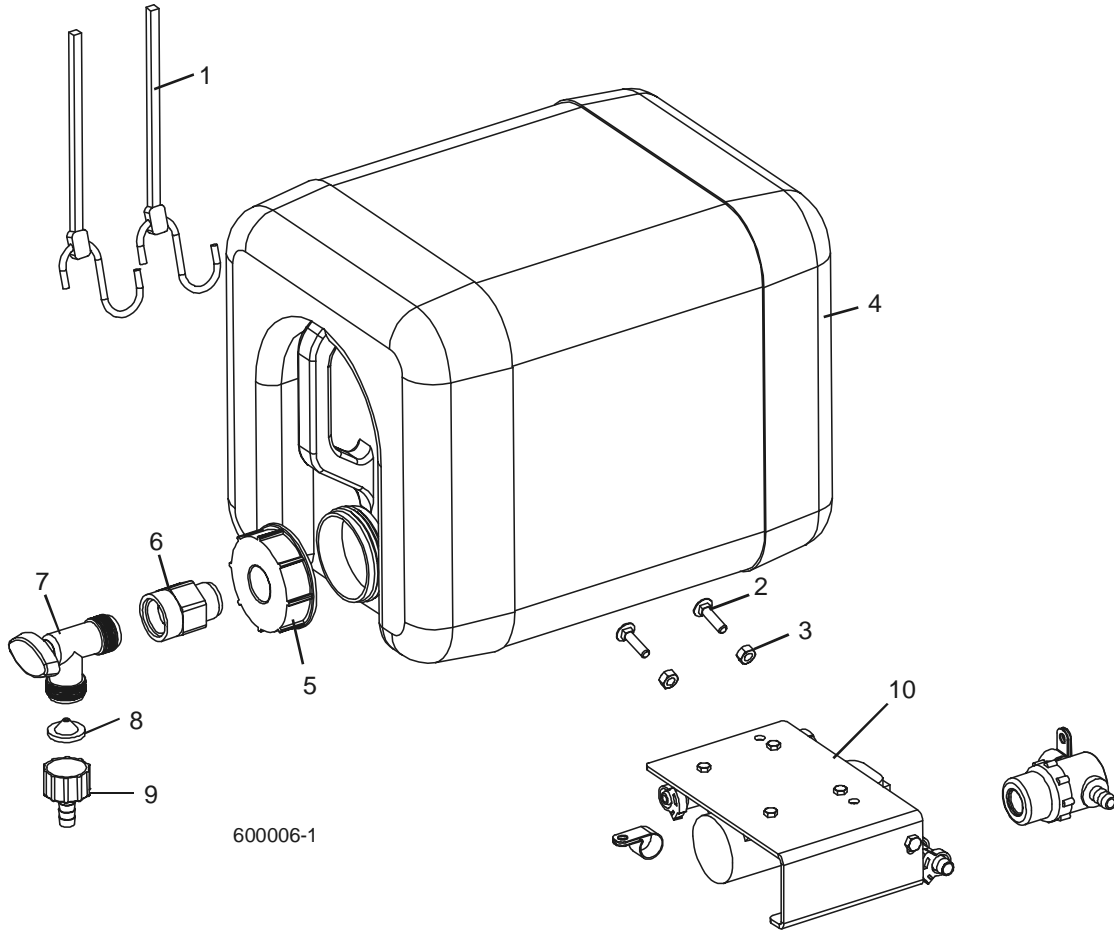

REF	DESCRIPTION (◆ Indicates Parts Available In Assemblies Only)	PART #	QTY.	
1	STRAP, 20" RUBBER	P11668	2	
2	BOLT, 1/4-20 X 1" CARRIAGE HEAD	F05005-34	2	
3	NUT, 1/4-20 HEX LOCK	F05010-21	2	
	BOTTLE ASSY, WATER LUBE	014642	1	
4	Bottle, 5-Gallon Water Lube	014637	1	◆
5	Cap, Water Lube Bottle Buttress Thread	014773	1	
6	FITTING, 3/4FPT X 3/4MPT	014636	1	
7	FITTING, WATER LUBE SHUTOFF VALVE	014100	1	
8	FILTER, WATER LUBE	016086	1	
9	FITTING, 5/8" NPT TO 3/8" HOSE BARB	014113	1	
10	LUBEMIZER PARTS/HOSES (SEE LUBEMIZER OPTION MANUAL)			

4.5 Saw Head Decals

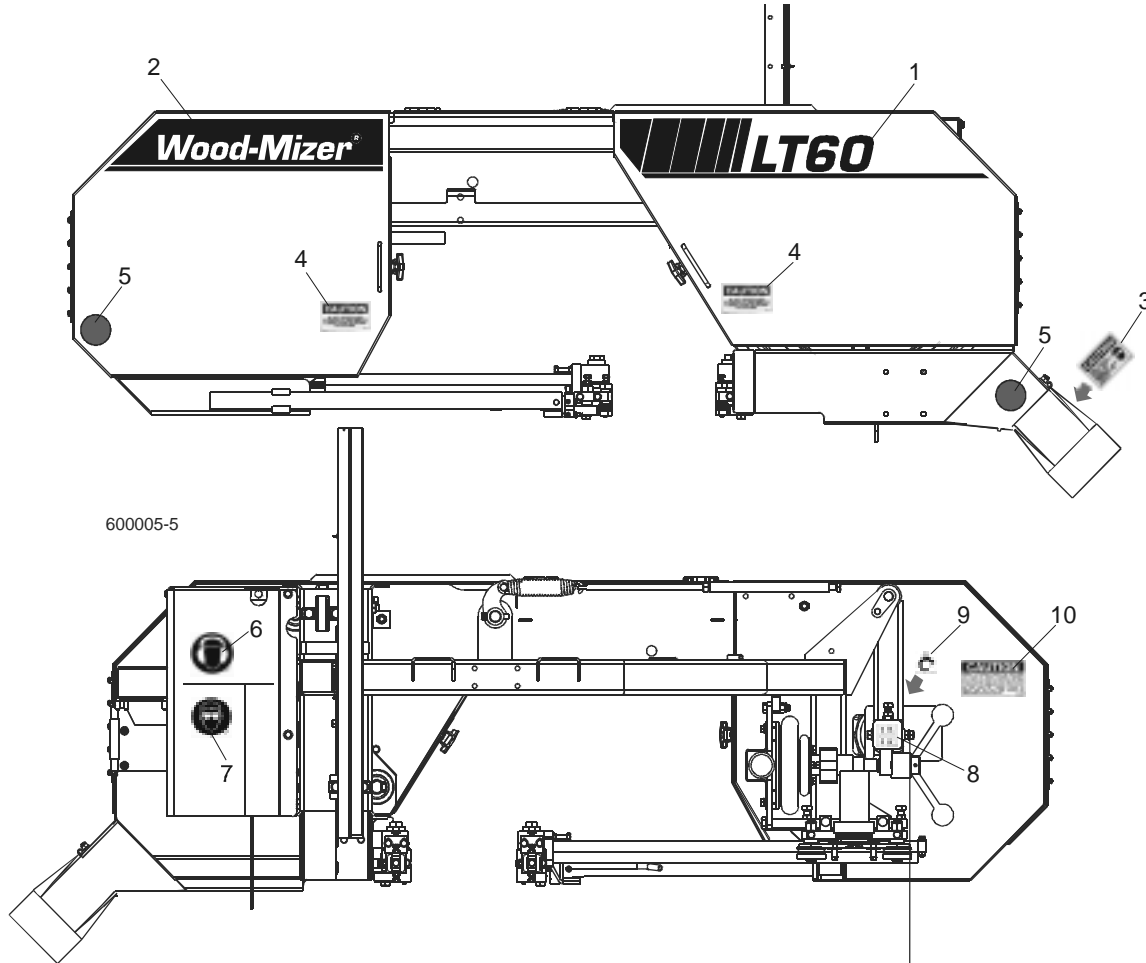

REF	DESCRIPTION (◆ Indicates Parts Available In Assemblies Only)	PART #	QTY.
1	DECAL, LT60 LOGO	088908	1
	DECAL, LT70 LOGO	089550	1
	DECAL, LT80 LOGO	087932	1
2	DECAL, WOOD-MIZER LOGO	087935	1
3	DECAL, SAWDUST CHUTE CAUTION	P11754	1
4	DECAL, BLADE COVERS DANGER	S20039	2
5	REFLECTOR, 2" RED	P07452	2
6	DECAY, EYE WARNING	S12004G	1
7	DECAL, EAR WARNING	S12005G	1
8	DECAL, BLADE ALIGNMENT	P11789	1
9	DECAL, BLADE TENSION SCREW	P11790	1
10	DECAL, SAW HEAD REST CAUTION	S12581	1

4 Saw Head

Blade Housing Covers

4.6 Blade Housing Covers

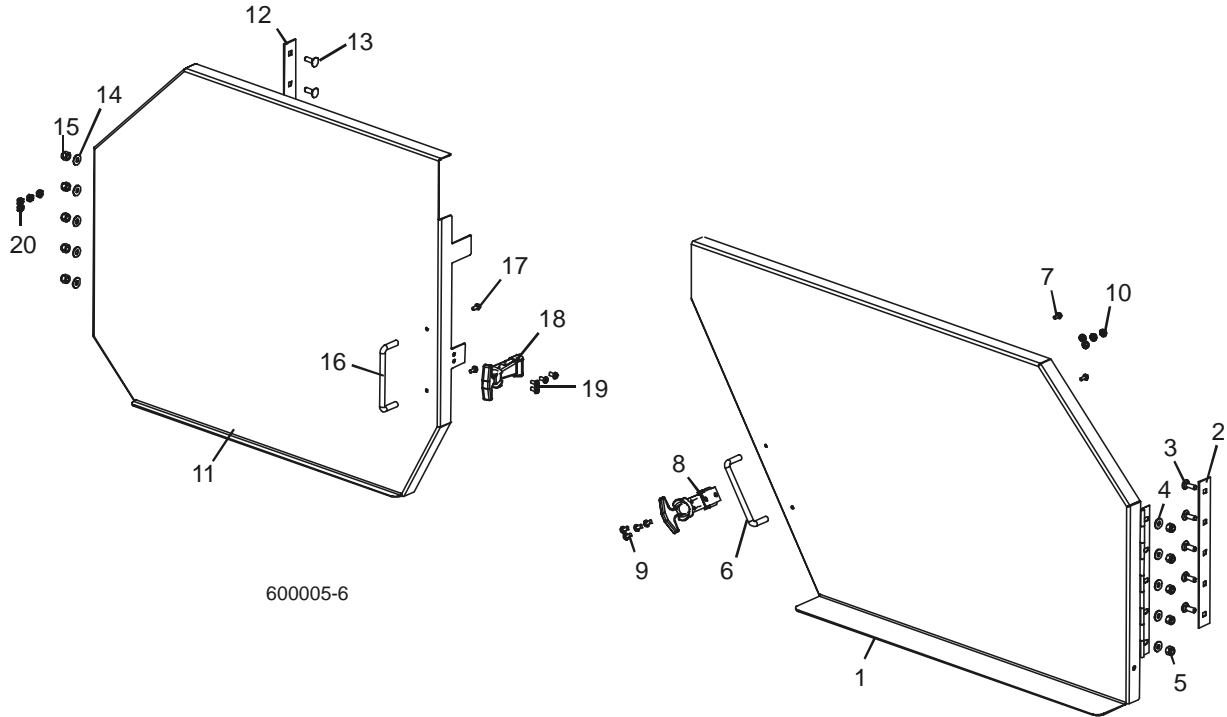

REF	DESCRIPTION (◆ Indicates Parts Available In Assemblies Only)	PART #	QTY.	
	COVER ASSEMBLY, DRIVE SIDE BLADE HOUSING	034374	1	
1	Cover Weldment, Drive Side Blade Housing	034317	1	◆
2	Plate, Hinge Backing	034251	1	
3	Bolt, 1/4-20 x 3/4" Carriage Head	F05005-113	5	
4	Washer, 1/4" SAE Flat	F05011-11	5	
5	Nut, 1/4-20 Hex Nylon Lock	F05010-69	5	
6	Handle, Blade Housing Cover	P08065	1	
7	Screw, #8-32 x 3/8" Self-tapping	F05015-8	2	
8	Latch, Flexible Draw	014829	1	
9	Screw, #10-24 x 3/8" Cross Slotted Pan Head	F05004-3	4	
10	Nut, #10-24 Hex Self-Locking	F05010-14	4	
	COVER ASSEMBLY, IDLE SIDE BLADE HOUSING	034375	1	
11	Cover Weldment, Idle Side Blade Housing	034318	1	◆
12	Plate, Hinge Backing	034251	1	
13	Bolt, 1/4-20 x 3/4" Carriage Head	F05005-113	5	
14	Washer, 1/4" SAE Flat	F05011-11	5	
15	Nut, 1/4-20 Hex Nylon Lock	F05010-69	5	
16	Handle, Blade Housing Cover	P08065	1	
17	Screw, #8-32 x 3/8" Self-tapping	F05015-8	2	
18	Latch, Flexible Draw	014829	1	

19	Screw, #10-24 x 3/8" Cross Slotted Pan Head	F05004-3	4	
20	Nut, #10-24 Hex Self-Locking	F05010-14	4	

4 Saw Head

Sawdust Chute

4.7 Sawdust Chute

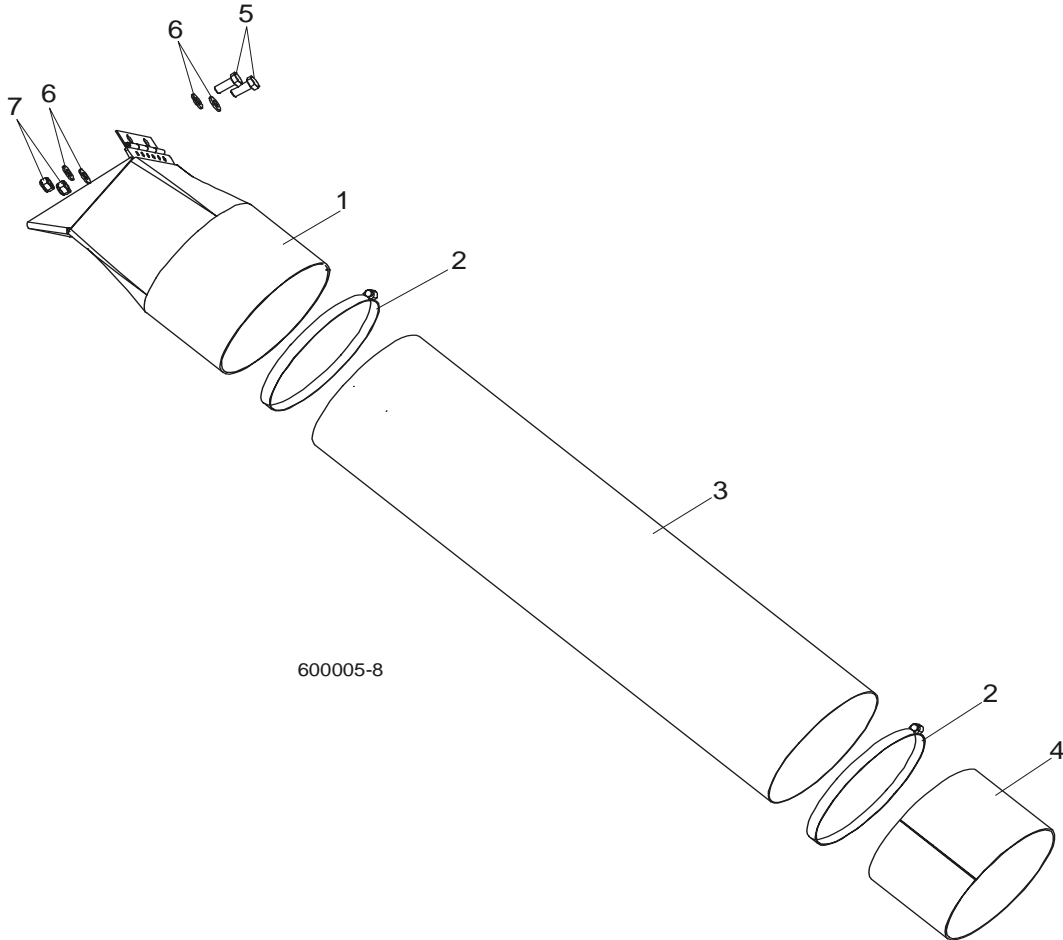

REF	DESCRIPTION (◆ Indicates Parts Available In Assemblies Only)	PART #	QTY.	
1	CHUTE WELDMENT, SAWDUST	089352-1	1	
2	CLAMP, 152 MM	089358	2	
3	TUBE, SAWDUST CHUTE	090153	1	
4	TUBE, CHUTE END	090126-1	1	
5	BOLT, M8X20-8.8-B HEX HEAD FULL THREAD ZINC	F81002-4	2	
6	WASHER 8.4 ZINC FLAT	F81054-1	4	
7	NUT, M8-8-B HEX NYLON ZINC LOCK	F81032-2	2	

5 Control & Battery Boxes

Control Assembly (Gas/Diesel)

SECTION 5 CONTROL & BATTERY BOXES

5.1 Control Assembly (Gas/Diesel)

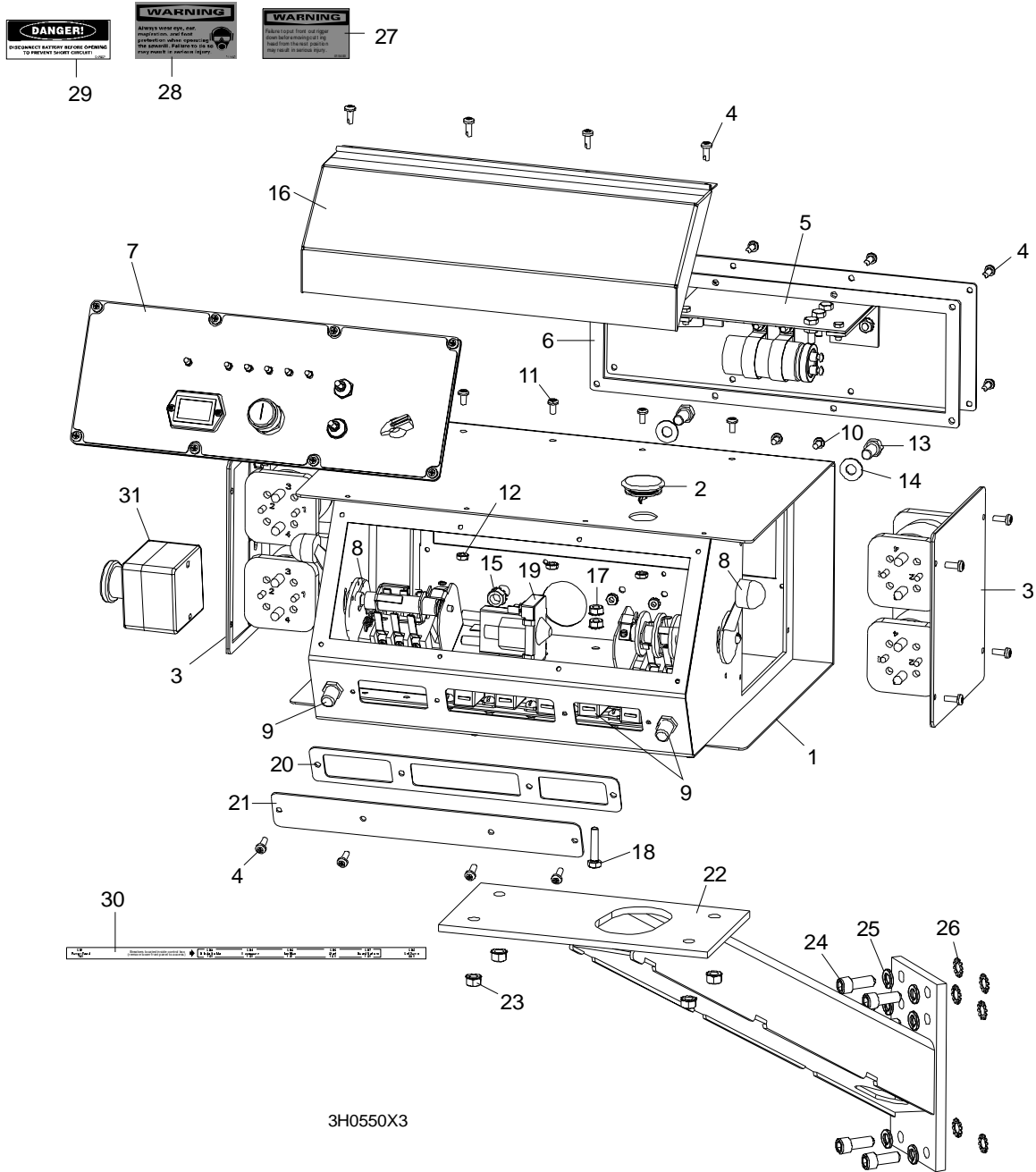

REF	DESCRIPTION (◆ Indicates Parts Available In Assemblies Only)	PART #	QTY.
	CONTROL BOX ASSEMBLY, E25	086571	1
	CONTROL BOX ASSEMBLY, D40	086572	1

1	Box Weldment, Sawmill Control	016135	1	◆
2	Plug, AS075 Oiltite	E20570	1	
3	Solenoid Parts (<i>See Section 5.4</i>)			
4	Screw, #10-24 x 1/2" Pan Head	F05015-17	16	
5	Panel Assembly, Power Feed Control	024412	1	
	Control Module, Power Feed SMT	024396-1	1	
6	Gasket, Rear Access Panel	015278	1	
7	Front Control Panel & Wiring Harnesses (<i>Section 5.5</i>)			
8	Drum Switches (<i>Section 5.2</i>)			
9	Circuit Breakers (<i>Section 5.3</i>)			
10	Screw, #10-24 x 3/8" Phillips Pan Head	F05004-3	2	
11	Screw, #10-24 x 3/8" Phillips Pan Head Machine with Neo Washer	F05004-148	4	
12	Nut, #10-24 Self Locking	F05010-14	6	
13	Bolt, 3/8-16 x 3/4" Hex Head	F05007-27	2	
14	Washer, 10.5 Flat	F81055-1	2	
15	Nut, 3/8" Lock Nut	F05010-19	2	
16	Cover, Control Box Hinged	015304	1	
17	Nut, 1/4-20 Self Locking	F05010-9	2	
18	Bolt, 1/4-20 x 1 1/4" Hex Head Tap	F05005-3	1	
19	Solenoid, Accessory	P10449	1	
	Diode Assembly, Solenoid Coil Chassis BND	087496	1	
20	Gasket, Front Access Panel	015266	1	
21	Panel, Control Box Front Access	086704-1	1	
22	MOUNT WELDMENT, STANDARD CONTROL BOX	086732-1	1	
23	NUT, 5/16-18 SELF-LOCKING HEX	F05010-20	4	
24	BOLT, M10 X 25-8.8 SOCKET HEAD	F81003-32	4	
25	WASHER, 10.2 SPLIT LOCK	F81055-2	4	
26	WASHER, 3/8" EXTERIOR STAR LOCK	F05011-36	4	
27	DECAL, FRONT OUTRIGGER WARNING	015400	1	
28	DECAL, EAR/EYE PROTECTION WARNING	S11753	1	
29	DECAL, DISCONNECT BATTERY DANGER	S12002	1	
30	DECAL, CIRCUIT BREAKER ID ('98 SUPER)	024362	1	
31	SWITCH, RED EMERGENCY STOP XALJ174F	E22703-2	1	

5.2 Drum Switches

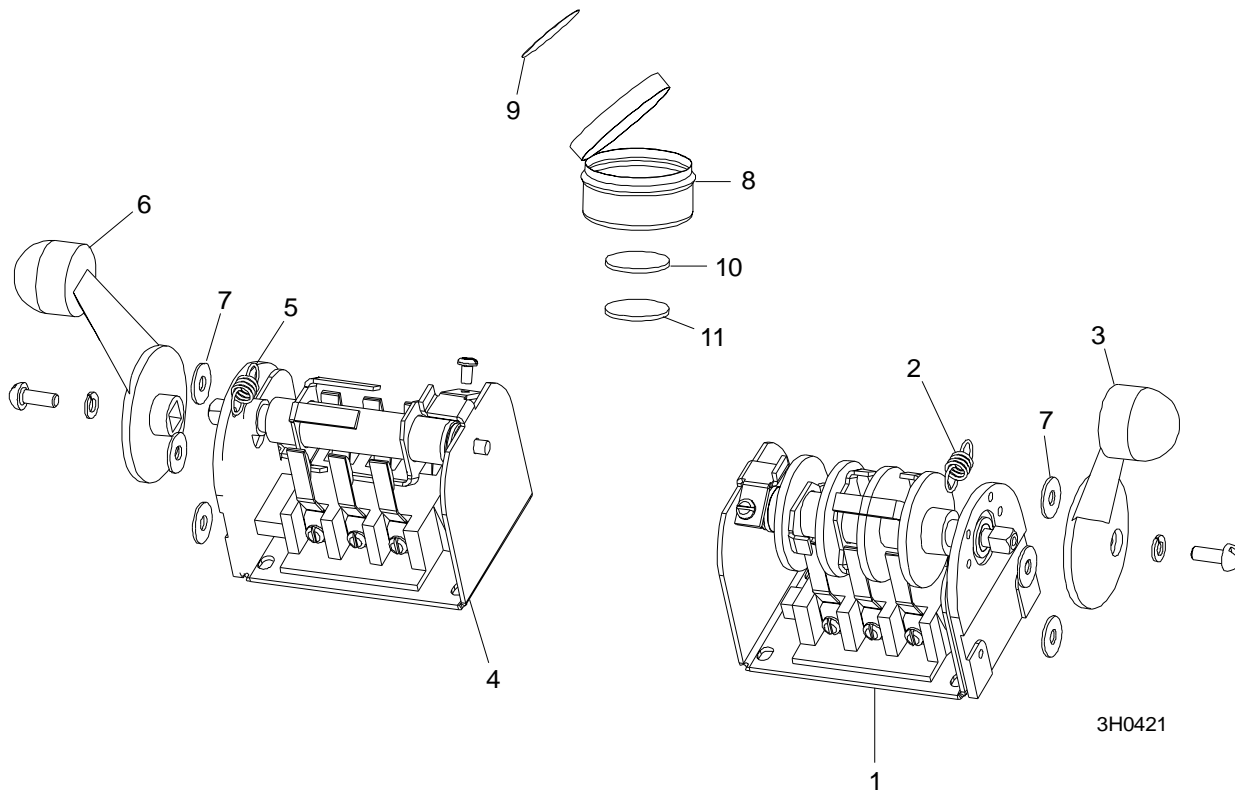

REF	DESCRIPTION (◆ Indicates Parts Available In Assemblies Only)	PART #	QTY.	
	SWITCH ASSEMBLY, UP/DOWN DRUM	E20440	1	
1	Switch, S12 Bulk Drum	E20440-B	1	◆
2	Spring, Drum Switch	P12570	1	
3	Handle, Drum Switch Replacement	P12500	1	
	SWITCH ASSEMBLY, POWER FEED DRUM	E20438	1	
4	Switch, S10 Bulk Drum	E20438-B	1	◆
5	Spring, Drum Switch	P12570	1	
6	Handle, Drum Switch Replacement	P12500	1	
7	WASHER, #8 SAE FLAT	F05011-41	6	
	CUP ASSEMBLY, DRUM SWITCH GREASE	A20463	1	
8	Cup, Plastic Container	P20464	1	◆
9	Decal, Grease Cup Label	P20467	1	
10	Pad, Velcro Loop	P20466	1	◆
11	Pad, Velcro Hook	P20465	1	◆
	Grease, High Temp Drum Switch	P20468	.011ml	◆

5.3 Front Panel Assembly & Harnesses

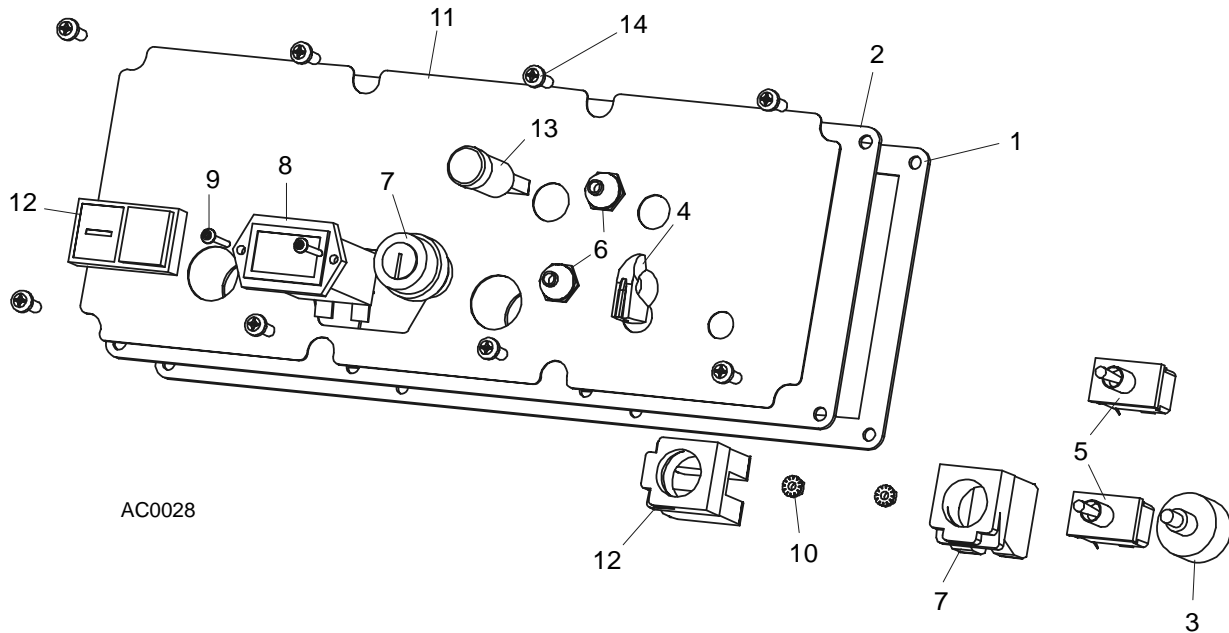

REF	DESCRIPTION (◆ Indicates Parts Available In Assemblies Only)	PART #	QTY.
	PANEL ASSEMBLY, AC SUPER CONTROL FRONT (EA20, EA25)	087387	1
1	Gasket, Front Panel	088387	1
2	Panel Weldment, Control	087316	1
3	Switch Assembly, Feed Rate	E20519	1
4	Knob, Feed Rate With Set Screw	P06257	1
5	Switch, Toggle	024200	2
6	Boot, Toggle Switch Rubber	P02575	2
7	Switch, Key	087350	1
8	Meter, Hour	015401	1
9	Screw, 6-42 x 3/4" Socket Button Head Cap Stainless Steel	F05004-93	2
10	Nut, 6-23 Self Locking	F05010-59	2
11	Decal, Control Pane	087351	1
12	Switch, START-STOP	087349	1
13	Lamp, Control	087348	1
	HARNESS ASSEMBLY, UPPER WIRING	024215	1
	HARNESS ASSEMBLY, LOWER WIRING	015421	1
14	Screw, #10-24 x 1/2" Pan Head	F05015-17	8

5.4 Circuit Breakers

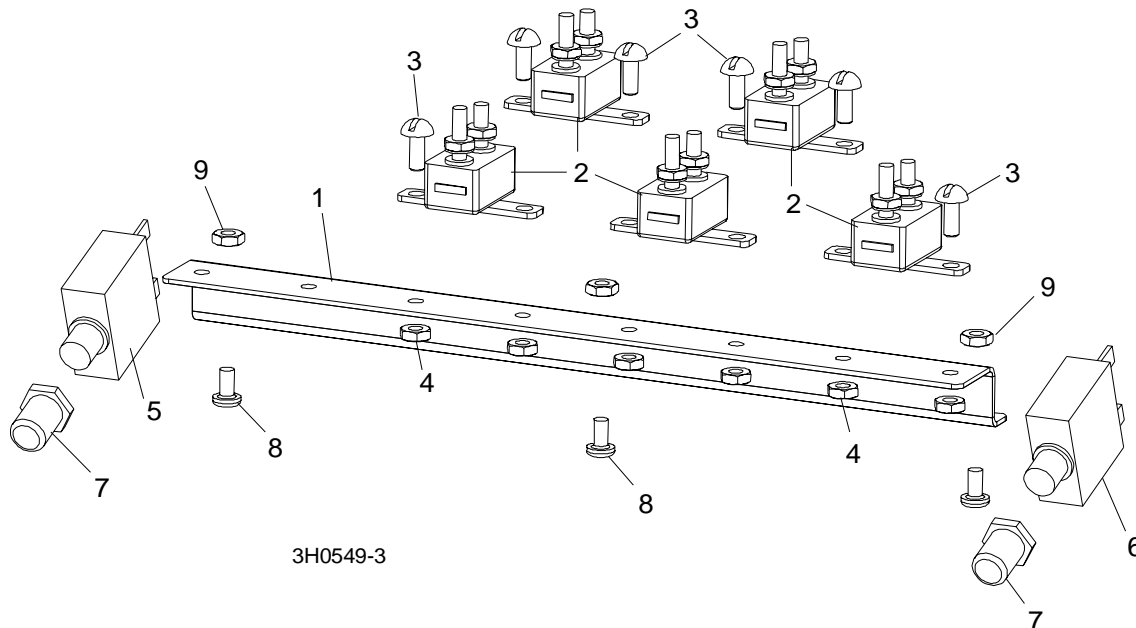

REF	DESCRIPTION (◆ Indicates Parts Available In Assemblies Only)	PART #	QTY.
	BREAKER ASSEMBLY, SAWMILL CONTROL CIRCUIT	015621	1
1	Rail, Circuit Breaker	015310	1
2	Breaker, 15 Amp Manual Reset	E20430	5
3	Screw, #8-32 X 1/2" Slotted Head	F05004-12	6
4	Nut, #8-32 Hex Self-Locking	F05010-41	6
5	BREAKER, 70 AMP MANUAL RESET PANEL MOUNT	015527	1
6	BREAKER, 50 AMP MANUAL RESET PANEL MOUNT	021256	1
7	BOOT, CIRCUIT BREAKER	021253	2
8	SCREW, #10-24 X 3/8" PHILLIPS PAN HEAD	F05004-3	3
9	NUT, #10-24 SELF LOCKING	F05010-14	3

SECTION 6 UP/DOWN SYSTEM

6.1 Up/Down Rollers & Covers

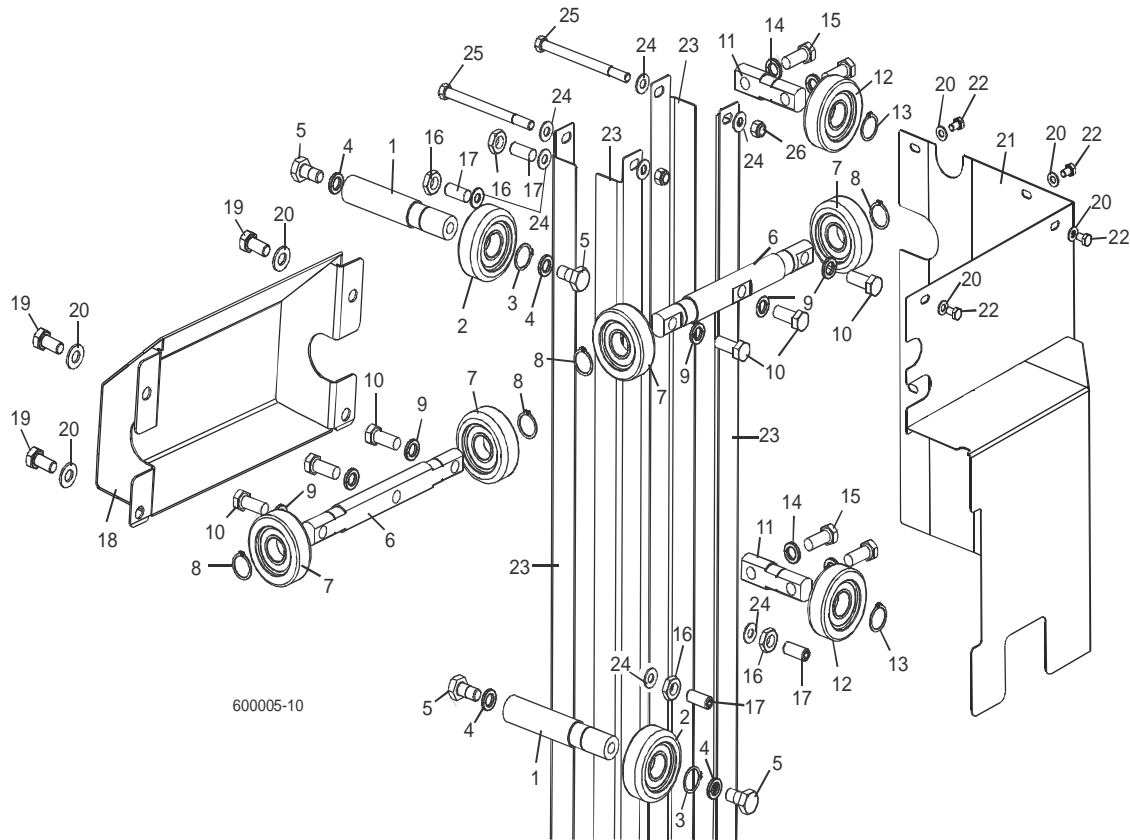

REF	DESCRIPTION (◆ Indicates Parts Available In Assemblies Only)	PART #	QTY.
	ROLLER ASSEMBLY, INSIDE UP/DOWN	089456	2
1	Shaft, Inside Up/Down Roller	088817	1
2	Bearing, CBK-468 Rolling	088433	1
3	Ring, Z30 Spring Retaining	F81090-23	1
4	Washer, 13 Zinc Flat	F81056-1	2
5	Bolt, M12x25-8.8 Hex Head Full Thread Zinc	F81004-31	2
	ROLLER ASSEMBLY, OUTSIDE UP/DOWN	089454	2
6	Shaft, Long Up/Down Roller	088815	1
7	Bearing, CBK-468 Rolling	088433	2
8	Ring, Z30 Spring Retaining	F81090-23	2
9	Washer, 10.5 Zinc Flat	F81055-1	3
10	Bolt, M10x35-8.8 Hex Head Full Thread Zinc	F81003-17	3

6

Up/Down System*Up/Down Rollers & Covers*

	ROLLER ASSEMBLY, SHORT UP/DOWN	089455	2	
11	Shaft, Short Up/Down Roller	088816	1	
12	Bearing, CBK-468 Rolling	088433	1	
13	Ring, Z30 Spring Retaining	F81090-23	1	
14	Washer, 10.5 Zinc Flat	F81055-1	2	
15	Bolt, M10x35-8.8 Hex Head Full Thread Zinc	F81003-17	2	
16	NUT, M10-04-W HEX ZINC THIN	F81033-6	4	
17	SCREW, GN 913.3-M10-40-MS SET	F81003-65	4	
18	COVER WELDMENT, UP/DOWN ROLLER	089483-1	1	
19	BOLT, M8X16-8.8-B HEX HEAD FULL THREAD ZINC	F81002-20	4	
20	WASHER, 8.4 ZINC FLAT	F81054-1	9	
21	COVER WELDMENT, LT80 AC/DC UP/DOWN DRIVE	089821-1	1	
22	BOLT, M8X12-8.8 HEX HEAD FULL THREAD ZINC	F81002-6	5	
23	ANGLE, MAST TUBE STAINLESS	088492	4	
24	WASHER, 10.5 ZINC FLAT	F81055-1	12	
25	BOLT, M10X125-8.8 HEX HEAD ZINC	F81003-18	4	
26	NUT, M10-8-B HEX NYLON ZINC LOCK	F81033-1	4	

6.2 Blade Height Scale

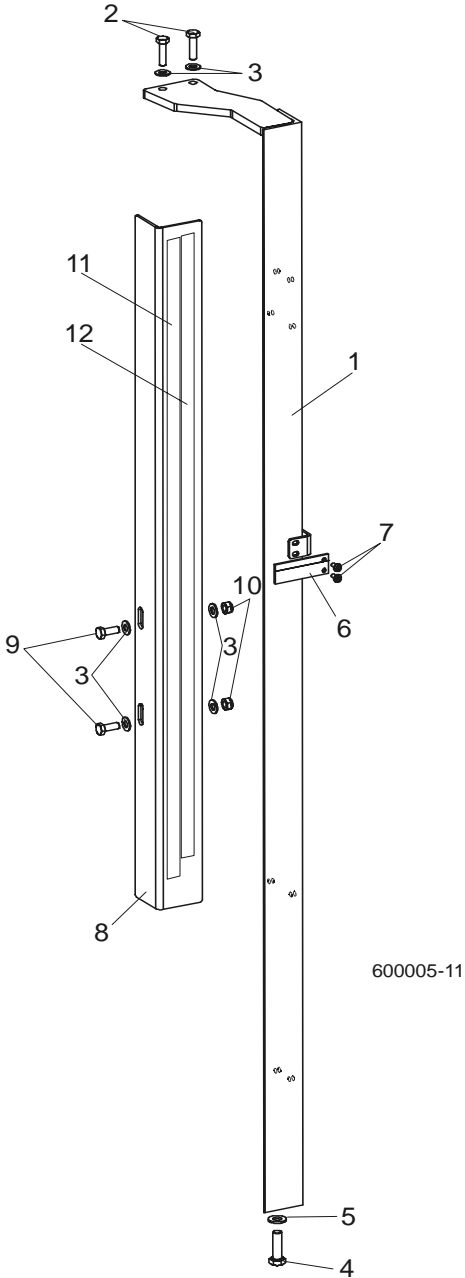

REF	DESCRIPTION (◆ Indicates Parts Available In Assemblies Only)	PART #	QTY.
1	MOUNT WELDMENT, SCALE PAINTED	088554-1	1
2	BOLT, M8 x 30-8.8-B HEX HEAD FULL THREAD ZINC	F81002-7	2
3	WASHER, 8.4 ZINC FLAT	F81054-1	6
4	BOLT, M10 x 35-8.8 HEX HEAD FULL THREAD ZINC	F81003-17	1
5	WASHER, 10.5 ZINC FLAT	F81055-1	1

6 Up/Down System

Blade Height Scale

6	POINTER, BLADE HEIGHT	086691-1	1	
7	SCREW, #10-24 X 3/8 PHILLIPS PAN HEAD ZINC	F05004-3	2	
8	ANGLE, SCALE MOUNT	088785-1	1	
9	BOLT, M8 X 20-8.8-B HEX HEAD FULL THREAD ZINC	F81002-4	2	
10	NUT, M8-8-B HEX NYLON ZINC LOCK	F81032-2	2	
11	DECAL, METRIC SCALE	S11711	1	
12	DECAL, 16-40 MM METRIC SCALE	P12040-1	1	

6.3 Up/Down Chain & Sprockets

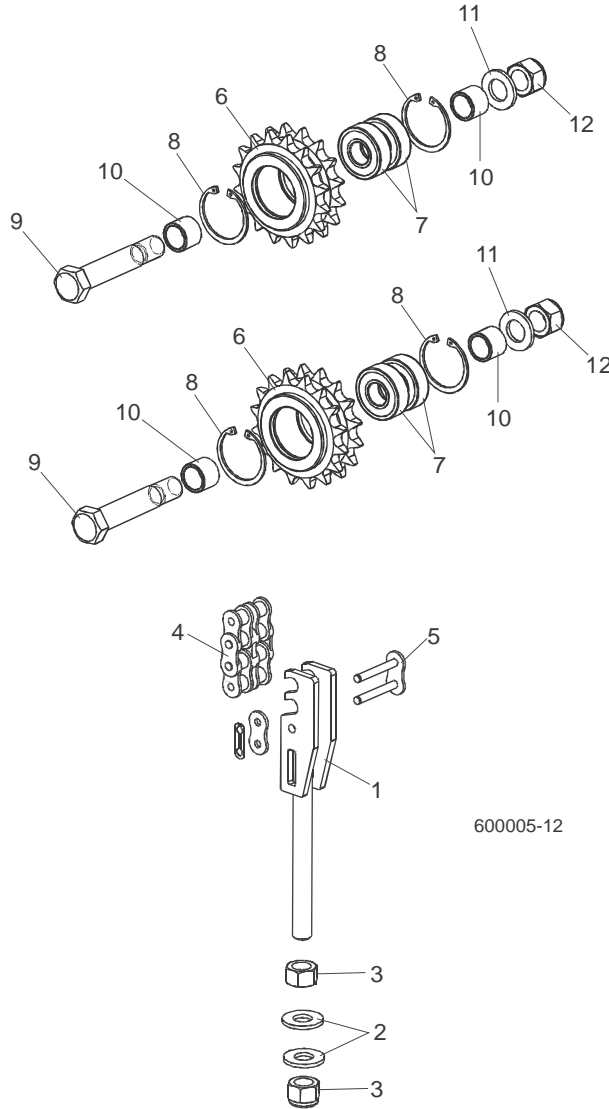

REF	DESCRIPTION (◆ Indicates Parts Available In Assemblies Only)	PART #	QTY.
1	TENSIONER WELDMENT, UP/DOWN CHAIN ZINC	088551-1	1
2	WASHER, 13 ZINC FLAT	F81056-1	2
3	NUT, M12-8 HEX NYLON ZINC LOCK	F81034-2	2
4	CHAIN, 10B-2 113-LINK UP/DOWN	088672	1
5	LINK, 10B-2Pz MASTER	088673	1
	SPROCKET ASSEMBLY, UP/DOWN IDLER	088470	1
6	Sprocket, Zinc	088471-1	1
7	Bearing, 6203-2RS FLT Rolling	086114	2

6 Up/Down System

Up/Down Chain & Sprockets

8	Ring, W40 Spring Retaining	F81090-3	2	
9	Bolt, M16D1F6 x 90-8.8 Hex Fit Short Thread Zinc	F81006-15	1	
10	Spacer, Idler Zinc	088792-1	2	
11	Washer, 17 Zinc Flat	F81058-1	1	
12	Nut, M16-8 Hex Nylon Zinc Lock	F81036-2	1	

6.4 Up/Down Drive Assembly

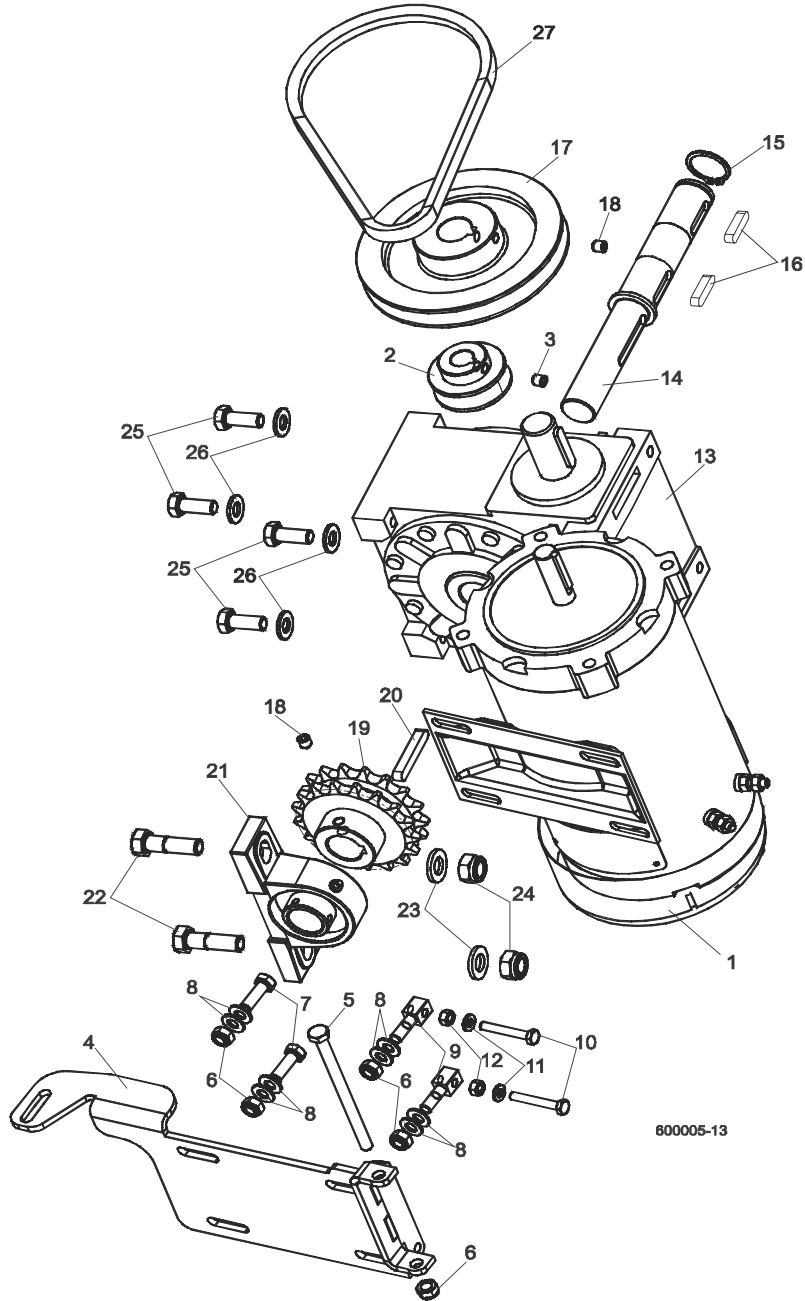

REF	DESCRIPTION (◆ Indicates Parts Available In Assemblies Only)	PART #	QTY.
	MOTOR W/MOUNT BRACKET, AC UP/DOWN	090493	1
1	AC Motor, 2 gear STKg90 6/4L2 IMB14/162	086530	1
2	Pulley, AC Motor	090497-1	1
3	Screw, M8x8-33H Hex Socket Set Flat Point Zinc	F81014-1	1

6

Up/Down System*Up/Down Drive Assembly*

4	Mount Weldment, DC Motor	088958-1	1	
5	Bolt, M8x120-8.8 Hex Head Zinc	F81002-25	1	
6	Nut, M8-8-B Hex Nylon Zinc Lock	F81032-2	5	
7	Bolt, M8x25-8.8-B Hex Head Full Thread Zinc	F81002-5	2	
8	Washer, 8.4 Zinc Flat	F81054-1	8	
9	Bolt, M8 Zinc Special	088962-1	2	
10	Bolt, M6x40-8.8 Hex Head Full Thread Zinc	F81001-5	2	
11	Washer, 6.4 Zinc Flat	F81053-1	2	
12	Nut, M6-8 Zinc Hex	F81031-1	2	
	GEAR ASSEMBLY, UP/DOWN DRIVE	088569	1	
13	Gear Box, RA-06/80/D1/N/V5	089453	1	
14	Shaft, RA-06 Up/Down Gear Output	088489	1	
15	Ring, Z28 Spring Retaining	F81090-12	1	
16	Key, A8X7X32 Parallel	088564	2	
17	Pulley, RA-06 Up/Down Gear	088926-1	1	
18	Screw, M8x8-33H Hex Socket Set Flat Point Zinc	F81014-1	1	
19	Sprocket, Up/Down Double	088469-1	1	
20	Key, A8X7X50 Parallel	088563	1	
21	Bearing, UCP205 CX w/Housing	088468	1	
22	BOLT, M12x40-8.8 HEX HEAD ZINC	F81004-1	2	
23	WASHER, 13 ZINC FLAT	F81056-1	2	
24	NUT, M12-8 HEX NYLON ZINC LOCK	F81034-2	2	
25	BOLT, M10x25-8.8 HEX HEAD FULL THREAD ZINC	F81003-11	4	
26	WASHER, 10.5 ZINC FLAT	F81055-1	4	
27	V-BELT, A590Lp (OPTIBELT)	089498	1	

SECTION 7 FEED SYSTEM & TRACK ROLLERS

7.1 Upper Track Rollers And Wipers

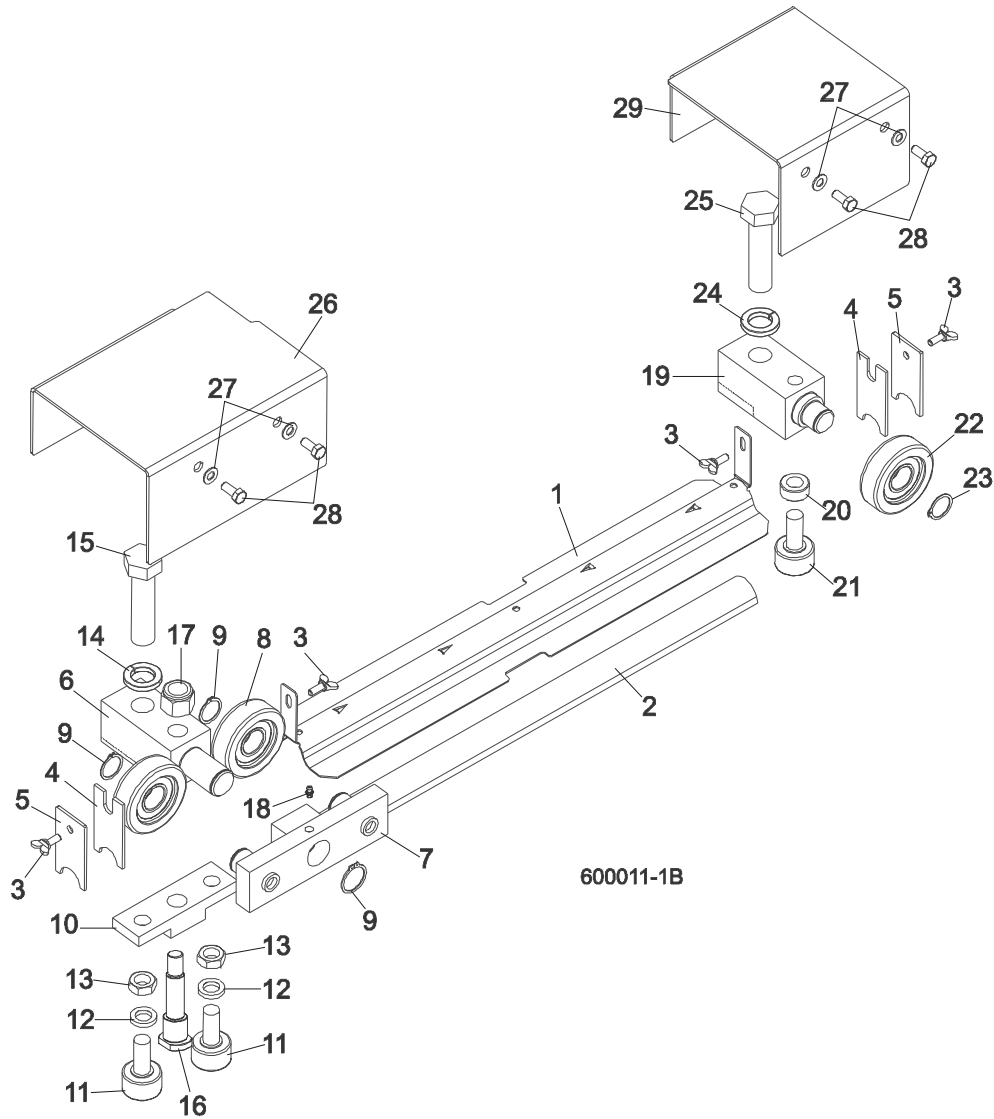

REF	DESCRIPTION (◆ Indicates Parts Available In Assemblies Only)	PART #	QTY.
1	COVER, MIDDLE TRACK	S09917	1
2	STRIP, FELT	S09915	1
3	SCREW, M6X16 DIN 316 WING	F81001-16	4
4	WIPER, TOP RAIL	M04113	2
5	PLATE, TRACK WIPER	088559-1	2
	ROLLER ASSEMBLY, UPPER TANDEM TRACK	088530	1
6	Block, Tandem Roller Mount	088532	1

Feed System & Track Rollers

Upper Track Rollers And Wipers

7

7	Block Assembly, Tandem Roller	088533	1	
8	Roller, CBK-468	088433	2	
9	Ring, Z30 Spring Retaining	F81090-23	2	
10	Block, Cam Follower Mount	088520	1	
11	Bearing, Cam Follower (McGill)	012797	2	
12	Washer, 16.3 Split Zinc Lock	F81058-2	2	
13	Nut, 5/8"-18 Zinc	F05010-11	2	
14	Washer, Z24.5 Split Zinc Lock	F81061-4	1	
15	Bolt, M24 x 2 x 90-8.8 Hex Head Full Thread Zinc	F81009-2	1	
16	Pin, Cam Follower Mount	088531	1	
17	Nut, M16-8 Hex Nylon Zinc Lock	F81036-2	1	
18	Fitting, M6 Straight Grease	086280	1	
	ROLLER ASSEMBLY, REAR UPPER TRACK	088529	1	
19	Block, Rear Upper Roller Mount	088528	1	
20	Spacer, Cam Follower	088536	1	
21	Bearing, Cam Follower (McGill)	012797	1	
22	Roller, CBK-468	088433	1	
23	Ring, Z30 Spring Retaining	F81090-23	1	
24	Washer, Z24.5 Split Zinc Lock	F81061-4	1	
25	Bolt, M24x2x90-8.8 Hex Head Full Thread Zinc	F81009-2	1	
26	COVER, TANDEM ROLLER	088526	1	
27	WASHER, 6.4 ZINC FLAT	F81053-1	4	
28	BOLT, M6X16 8.8 HEX HEAD FULL THREAD ZINC	F81001-15	4	
29	COVER, REAR UPPER ROLLER	088527	1	

7 Feed System & Track Rollers

Power Feed Assembly

7.2 Power Feed Assembly

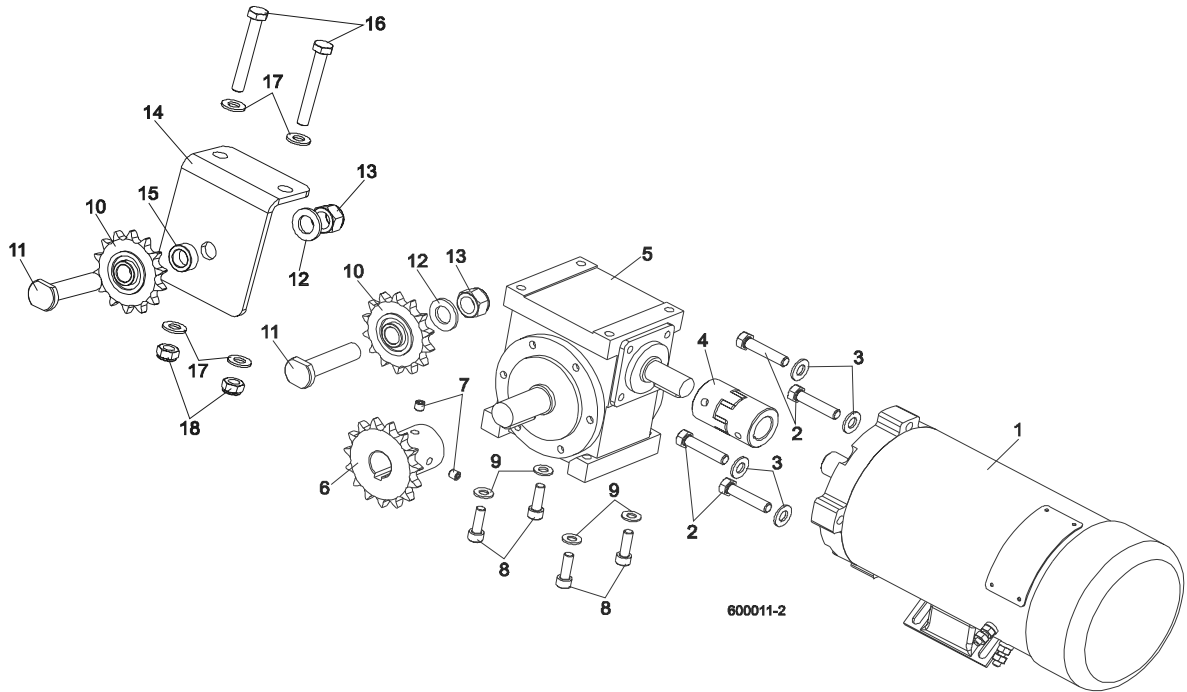

REF	DESCRIPTION (◆ Indicates Parts Available In Assemblies Only)	PART #	QTY.
1	MOTOR, 3/4 HP 12VDC TEFC LEESON	023688	1
2	BOLT, 3/8-16x1 3/4 HEX HEAD FULL THREAD	F05007-19	4
3	WASHER, 10.5 ZINC FLAT	F81055-1	4
4	COUPLING, SPIDEX 19/24 b/b ST 92Sh	088542	1
5	GEAR BOX, RA-05/7,5/D1/S+N/B8 W/OUTPUT SHAFT	088578	1
6	SPROCKET, 10B Z15 ZINC	088541-1	1
7	SCREW, M8x8-33H HEX SOCKET SET FLAT POINT ZINC	F81014-1	2
8	SCREW, M8x25 -8.8 HEX SOCKET HEAD CAP ZINC	F81002-21	4
9	WASHER, 8.4 ZINC FLAT	F81054-1	4
10	SPROCKET, KSR 16.L0.10.10.14.08 W/BEARING	088867	2
11	PIN, ZINC SPROCKET MOUNT	088994-1	2
12	WASHER, 17 ZINC FLAT	F81058-1	2
13	NUT, M16-8 HEX NYLON ZINC LOCK	F81036-2	2
14	BRACKET, POWER FEED SPROCKET MOUNT	088507-1	1
15	SPACER, POWER FEED SPROCKET	088550-1	1
16	BOLT, M10x75-8.8 HEX HEAD ZINC	F81003-15	2
17	WASHER, 10.5 ZINC FLAT	F81055-1	4
18	NUT, M10-8-B HEX NYLON ZINC LOCK	F81033-1	2

7.3 Feed Chain/Stop, LT60AHD/LT70AHD

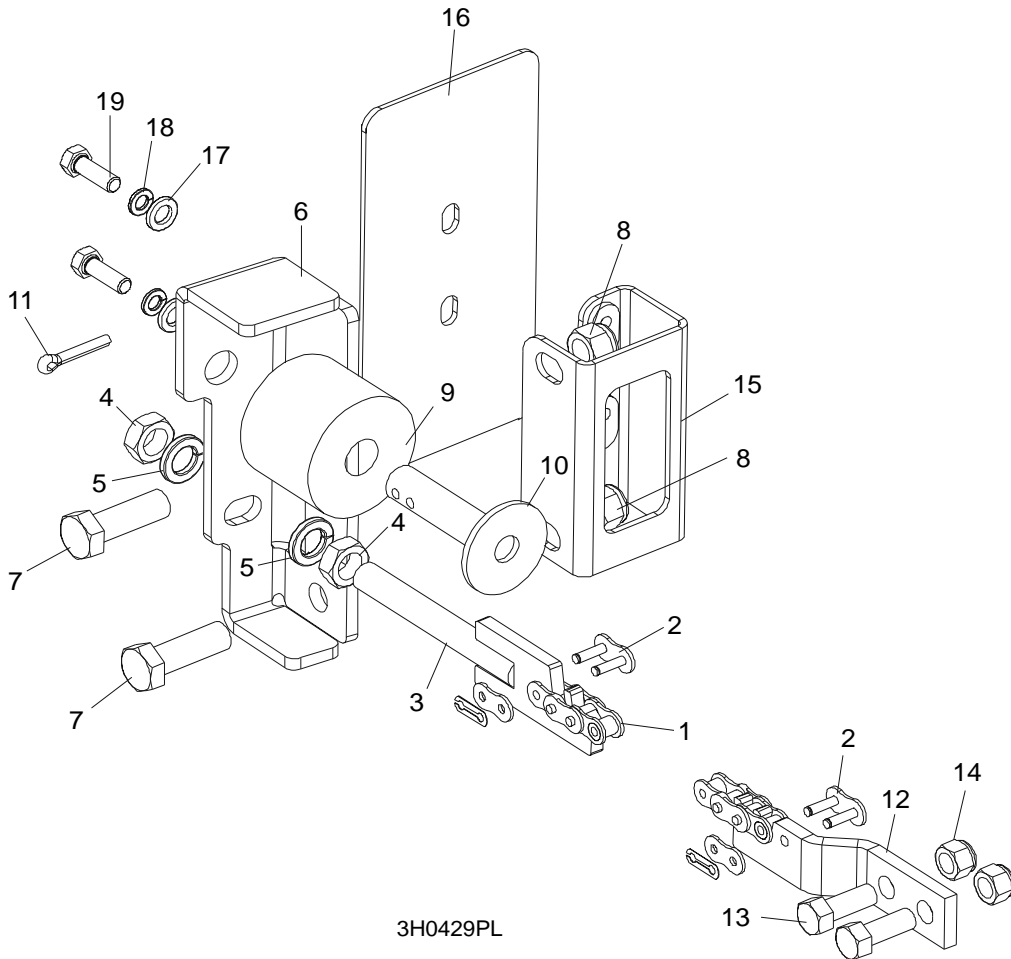

3H0429PL

REF	DESCRIPTION (◆ Indicates Parts Available In Assemblies Only)	PART #	QTY.
	CHAIN KIT, LT30 FEED	K10408	1
	CHAIN KIT, LT40 FEED	K10410	1
1	Chain, #40 X 215" LT30 Feed	014744	1
	Chain, #40 X 267.5" LT40 Feed	014475	1
2	Link, #40 Master	P04200	2
3	Tensioner Weldment, Power Feed Chain	086818-1	1
4	Nut, M12-5 Hex Jam	F81034-4	2
5	Washer, 12.2 Split Lock	F81056-2	2
6	BRACKET, FEED CHAIN REAR MOUNT	087628-1	1
7	BOLT, M12 X 40 8.8 HEX HEAD GRADE 5	F81004-4	2
8	NUT, M12-8 HEX NYLON LOCK	F81034-2	2
	STOP KIT, RUBBER CARRIAGE	K09630	2
9	Stop, Rubber Carriage	P12165	1

7 Feed System & Track Rollers

Feed Chain/Stop, LT60AHD/LT70AHD

10	Pin, Rubber Carriage Stop	W09293	1	
11	Pin, 3/16" X 1" Cotter	F05012-21	1	
12	BRACKET, FRONT FEED CHAIN MOUNT	015008	1	
13	BOLT, 3/8-16 X 1" HEX HEAD	F05007-7	2	
14	NUT, 3/8-16 HEX NYLON LOCK	F05010-10	2	
15	BRACKET WELDMENT, REAR MAIN TUBE COVER MOUNT	087105-1	1	
16	COVER, REAR MAIN TUBE	015023	1	
17	WASHER, 8.4 FLAT	F81054-1	2	
18	WASHER, 8.2 SPLIT LOCK	F81054-4	2	
19	BOLT, 5/16-18 X 1" HEX HEAD	F05006-1	2	

7.4 Lower Track Rollers

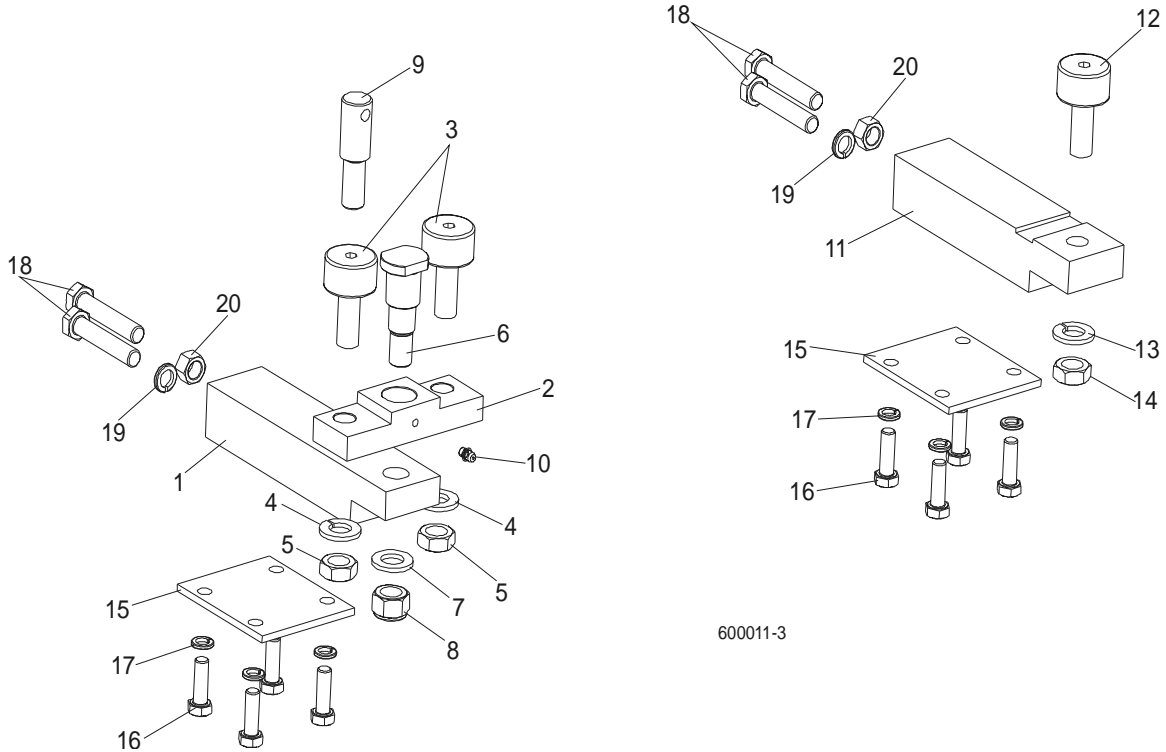

600011-3

REF	DESCRIPTION (◆ Indicates Parts Available In Assemblies Only)	PART #	QTY.
	BLOCK ASSEMBLY, VERTICAL MAST ALIGNMENT DOUBLE	088523	1
1	Block, Vertical Mast Alignment Double	088517	1
2	Block, Cam Follower Mount	088520	1
3	Bearing, Cam Follower (McGill)	012797	2
4	Washer, 16.3 Split Zinc Lock	F81058-2	2
5	Nut, 5/8"-18 Zinc	F05010-11	2
6	Pin, Cam Follower Mount	088521	1
7	Washer, 17 Zinc Flat	F81058-1	1
8	Nut, M16-8 Hex Nylon Zinc Lock	F81036-2	1
9	Pin, Safety Lock	088519	1
10	Fitting, M6 Straight Grease	086280	1
	BLOCK ASSEMBLY, VERTICAL MAST ALIGNMENT SINGLE	088524	1
11	Block, Vertical Mast Alignment Single	088518	1
12	Bearing, Cam Follower (McGill)	012797	1
13	Washer, 16.3 Split Zinc Lock	F81058-2	1
14	Nut, 5/8"-18 Zinc	F05010-11	1
15	PLATE, LOWER TRACK ROLLER RETAINER	088516	2
16	BOLT, M10X30-5.8 HEX HEAD FULL THREAD ZINC	F81003-2	8
17	WASHER, 10.2 SPLIT ZINC LOCK	F81055-2	8

7 Feed System & Track Rollers

Lower Track Rollers

18	BOLT, M12X1.25X65-8.8 HEX HEAD FULL THREAD ZINC	F81004-40	4	
19	WASHER, Z12.2 SPLIT ZINC LOCK	F81056-2	2	
20	NUT, M12X1.25-8 ZINC HEX	F81034-8	2	

SECTION 8 BED FRAME ASSEMBLY

8.1 Bed Rail Assembly, Front And Rear

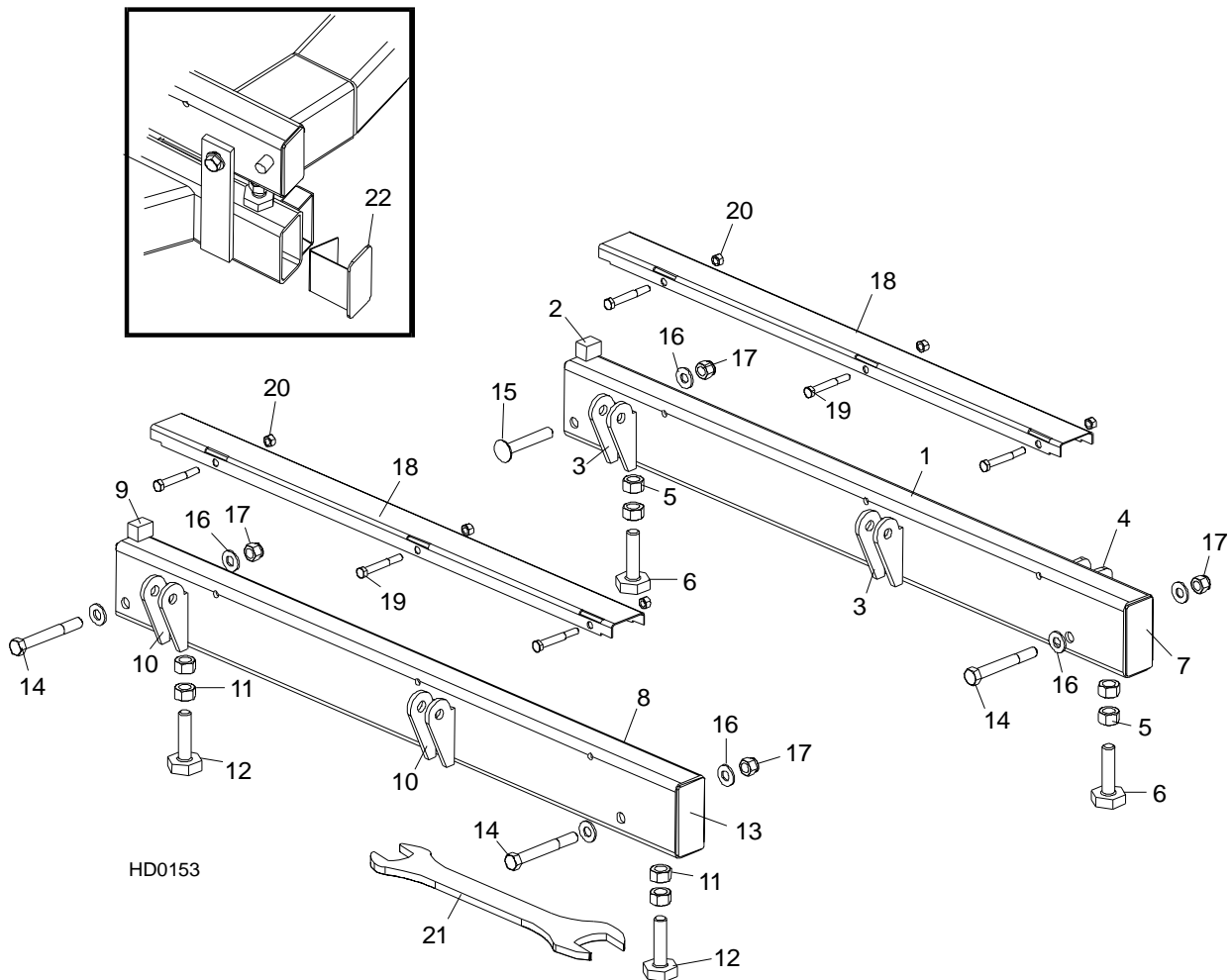

REF	DESCRIPTION (◆ Indicates Parts Available In Assemblies Only)	PART #	QTY.	
	BED RAIL ASSEMBLY, REAR PAINTED	014467	1	
1	Bed Rail Tube, Long	015974	1	◆
2	Block, Log Stop	S09034	1	
3	Bracket, Roller Toe Board Mount	S13021	4	◆
4	Bracket, Saw Head Rest Pin Mount	014150	2	◆
	Bolt Assembly, Bed Rail	086809	2	◆
5	Nut, 5/8-11 Hex	F05010-54	2	
6	Bolt, Bed Rail Adjustment	S13006	1	
7	Plate, Bed Rail End Cap	S04058	2	◆

8

Bed Frame Assembly*Bed Rail Assembly, Front And Rear*

	BED RAIL ASSEMBLY, FRONT PAINTED	014455	1	
8	Bed Rail Tube, Long	015974	1	◆
9	Block, Log Stop	S09034	1	
10	Bracket, Roller Toe Board Mount	S13021	4	◆
	Bolt Assembly, Bed Rail	086809	2	◆
11	Nut, 5/8-11 Hex	F05010-54	2	
12	Bolt, Bed Rail Adjustment	S13006	1	
13	Plate, Bed Rail End Cap	S04058	2	◆
14	BOLT, M12 X 100-8.8 HEX HEAD	F81004-3	3	
15	BOLT, 1/2-13 X 3 1/2" CARRIAGE	F05008-94 ¹	1	
16	WASHER, 13 FLAT	F81056-1	7	
17	NUT, M12-8 NYLON LOCK	F81034-2	4	
	COVER ASSEMBLY, STAINLESS STEEL BED RAIL (LONG)	A09956	2	
18	Cover, Stainless Steel Bed Rail	S09944	1	◆
19	Bolt, 5/16-18 X 2 1/2" Hex Head	F05006-10	3	
20	Nut, 5/16-18 Hex Lock	F05010-6	3	
21	WRENCH, BED RAIL ADJUSTMENT	015970	1	
22	CAP WELDMENT, BED RAIL REMOVABLE END	014652	2	

¹ Used on rear bed rail to allow clearance for side support rollers.

8.2 Bed Rail Assembly, Front Middle

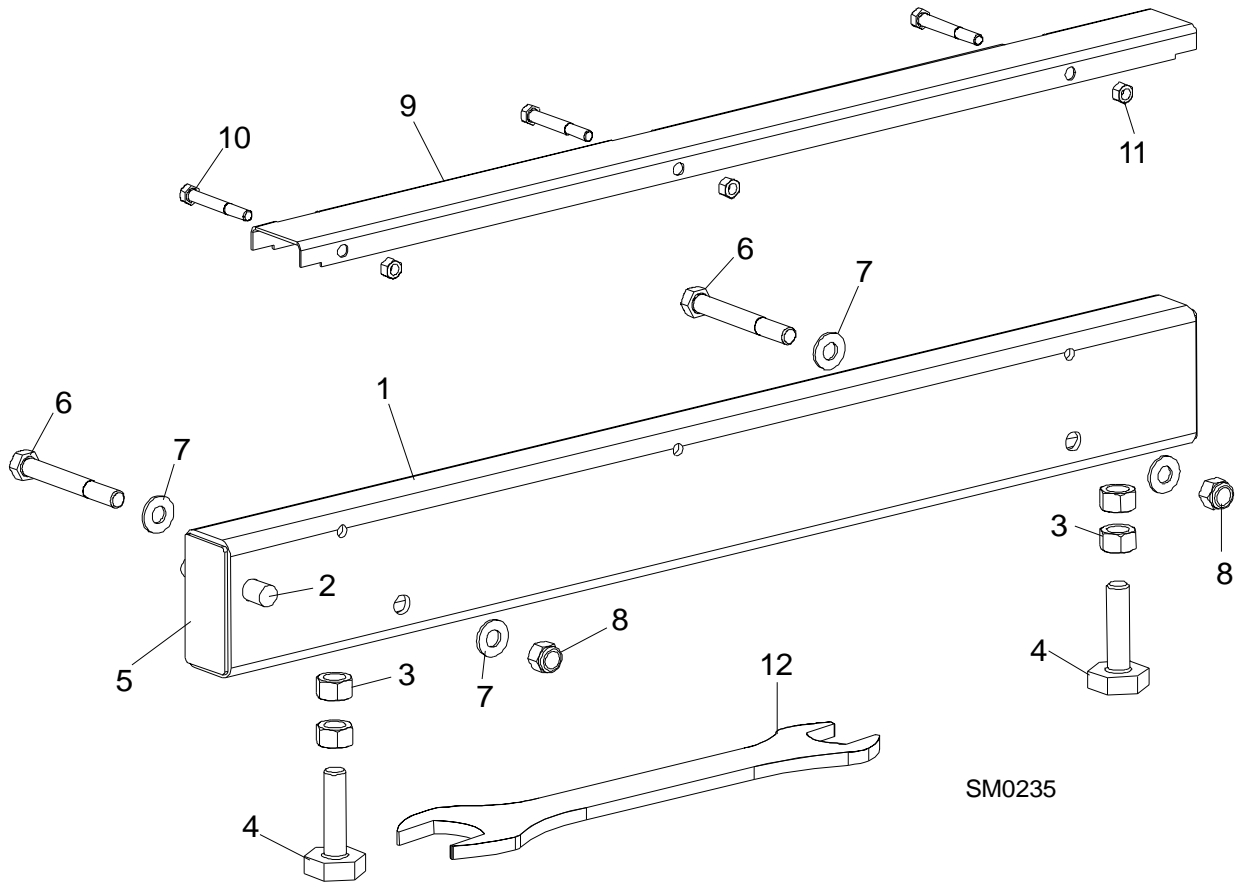

REF	DESCRIPTION (◆ Indicates Parts Available In Assemblies Only)	PART #	QTY.	
	BED RAIL ASSEMBLY, FRONT MIDDLE	A09566	1	
1	Bed Rail Tube, Short	S09103	1	◆
2	Pin, Ramp Mount	S04030	1	
	Bolt Assembly, Bed Rail	086809	2	◆
3	Nut, 5/8-11 Hex	F05010-54	2	
4	Bolt, Bed Rail Adjustment	S13006	2	
5	Plate, Bed Rail End Cap	S04058	2	◆
6	BOLT, M12 X 100-8.8 HEX HEAD	F81004-3	2	
7	WASHER, 13 FLAT	F81056-1	4	
8	NUT, M12-8 HEX NYLON LOCK	F81034-2	2	
	COVER ASSEMBLY, STAINLESS STEEL BED RAIL (LONG)	A09956	1	
9	Cover, Stainless Steel Bed Rail	S09944	1	◆
10	Bolt, M8x65-5,8 Zinc Hex Head	F81002-3	3	
11	Nut, M8-8-B-Zinc Hex Nylon Lock	F81032-2	3	

8**Bed Frame Assembly***Bed Rail Assembly, Front Middle*

12	WRENCH, BED RAIL ADJUSTMENT	015970	1	
----	-----------------------------	--------	---	--

8.3 Bed Rail Assembly, Rear Middle

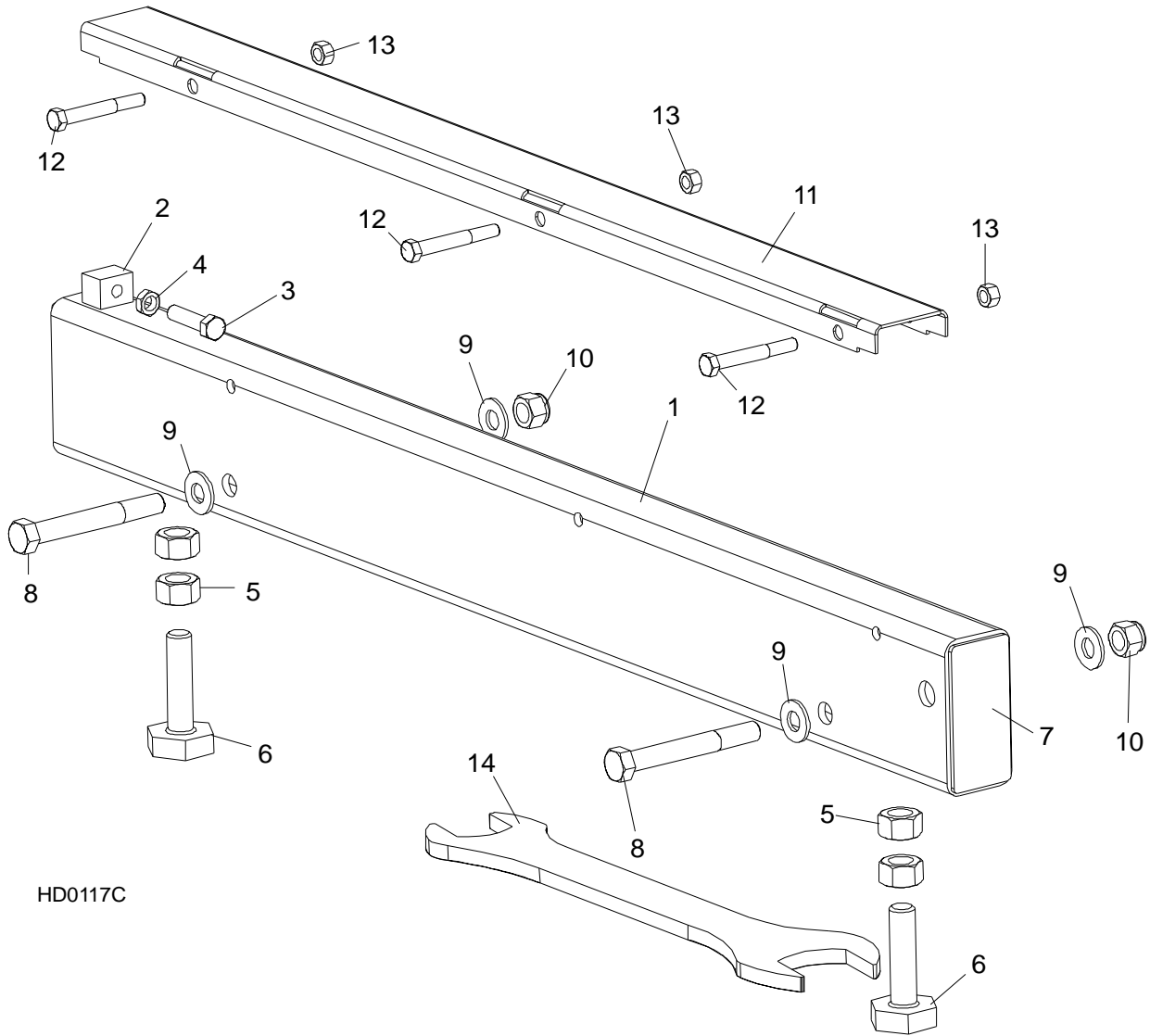

HD0117C

REF	DESCRIPTION (◆ Indicates Parts Available In Assemblies Only)	PART #	QTY.	
13	BOLT, M12 X 100-8.8 HEX HEAD	F81004-3	2	
14	WASHER, 13 FLAT	F81056-1	4	
15	NUT, M12-8 NYLON LOCK	F81034-2	2	
	COVER ASSEMBLY, STAINLESS STEEL BED RAIL (LONG)	A09956	1	
16	Cover, Stainless Steel Bed Rail	S09944	1	◆
17	Bolt, M8x65-5,8 Zinc Hex Head	F81002-3	3	
18	Nut, M8-8-B-Zinc Hex Nylon Lock	F81032-2	3	
19	WRENCH, BED RAIL ADJUSTMENT	015970	1	

8 Bed Frame Assembly

Leg, Stationary

8.4 Leg, Stationary

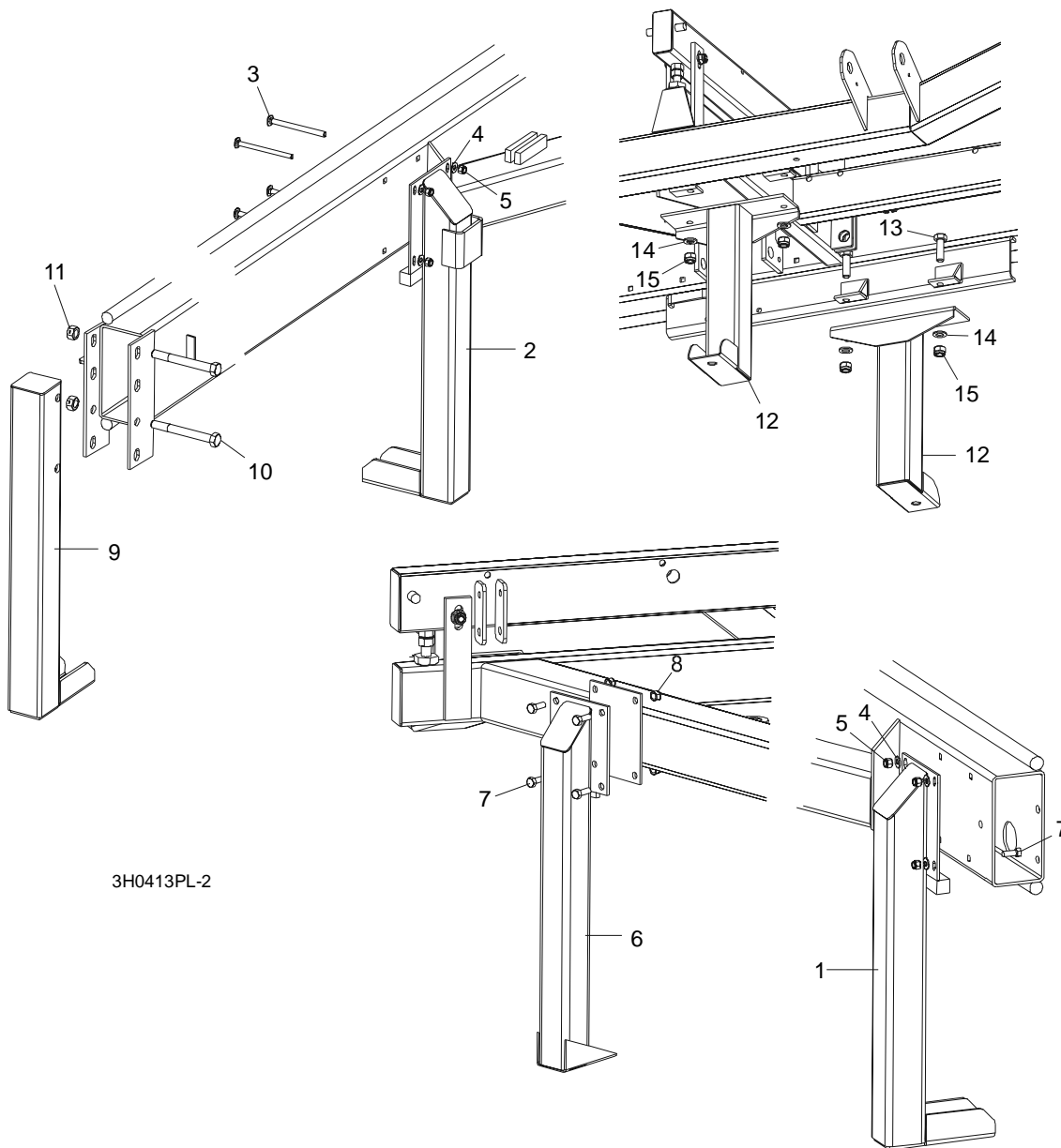

REF	DESCRIPTION (◆ Indicates Parts Available In Assemblies Only)	PART #	QTY.
1	LEG, LONG RIGHT STATIONARY (1 REQ'D FOR LT30; 3 REQ'D FOR LT40)	087451-1	1/3
2	LEG, LONG STATIONARY W/BOARD RETURN TABLE BRACKET	087449-1	1
3	BOLT, M10 X 120-8.8 CARRIAGE HEAD	F81003-33	8/12
4	WASHER, 10.5 FLAT	F81055-1	8/16
5	NUT, M10-8-B HEX NYLON LOCK	F81033-1	8/16

Bed Frame Assembly
Leg, Stationary

8

6	LEG, SHORT LEFT STATIONARY	087450-1	2	
7	BOLT, M10 X 25-8.8 HEX HEAD	F81003-11	12	
8	NUT, M10-8-B HEX NYLON LOCK	F81033-1	12	
9	LEG, FRONT STATIONARY	087452-1	1	
10	BOLT, M16 X 140-8.8 HEX HEAD GRADE 5	F81006-4	2	
11	NUT, M16-8 HEX LOCK	F81036-2	2	
12	LEG, MIDDLE STATIONARY	087093-1	2	
13	BOLT, M16 X 50-8.8 HEX HEAD	F81006-7	4	
14	WASHER, 17 FLAT	F81058-1	4	
15	NUT, M16 NYLON LOCK	F81036-2	4	

8.5 Board Return Table Assembly

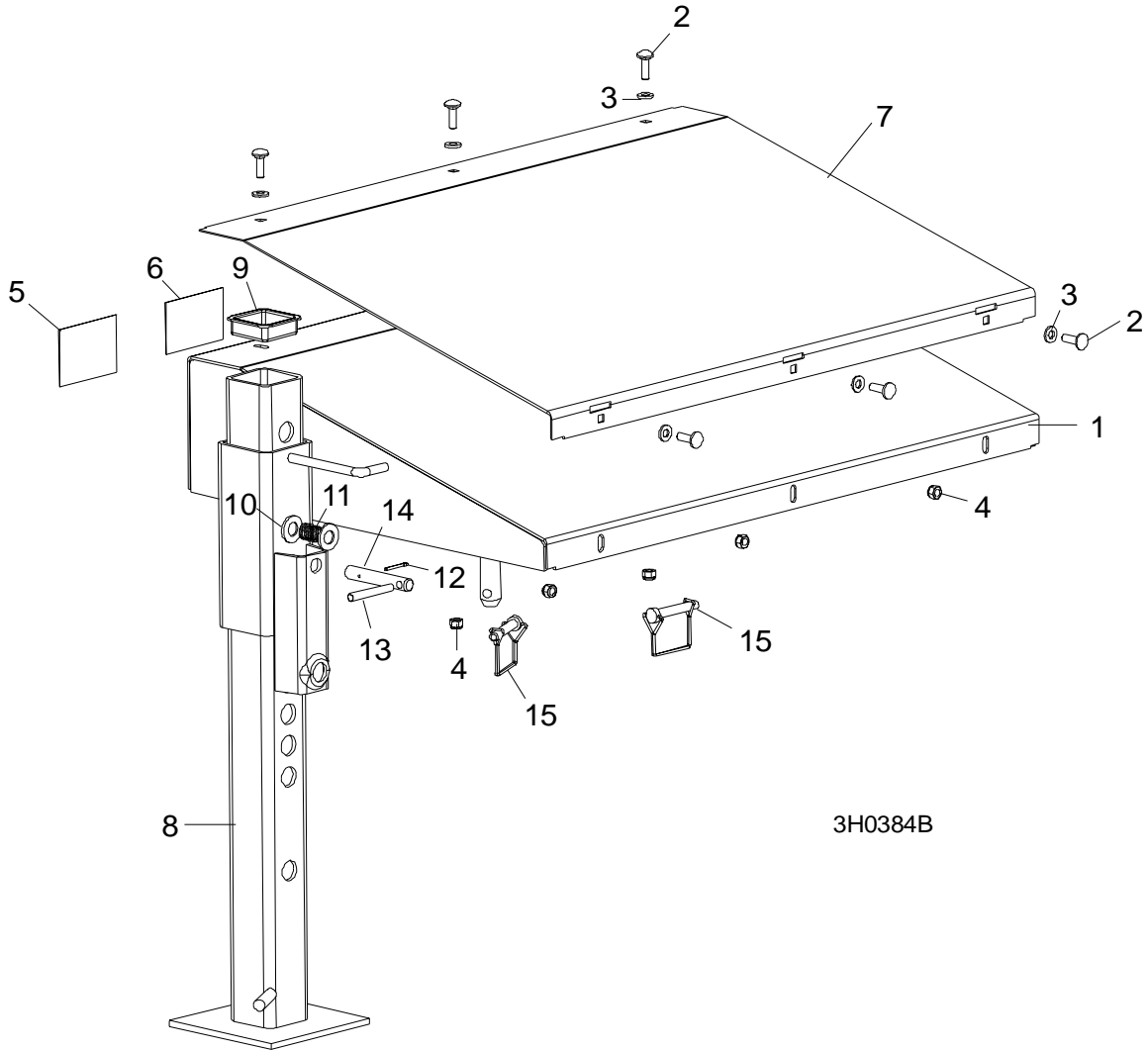

3H0384B

	DESCRIPTION (◆ Indicates Parts Available In Assemblies Only)	PART #	QTY.	
	TABLE ASSEMBLY, BOARD RETURN	015792	1	
1	Table Weldment, Board Return	015790	1	◆
2	Bolt, 5/16-18 x 1" Carriage Head	F81002-1	6	
3	Washer, 5/16" SAE Flat	F81032-2	6	
4	Nut, 5/16-18 Nylon Lock	F81054-1	6	
5	Decal, Board Return Danger	015365	1	
6	Decal, Board Return Table Warning	016077	1	
7	Plate, Return Table Stainless Steel	015791	1	
8	Leg Weldment, Painted Outrigger	W07537	1	
9	Cap, Outrigger Leg	P09926	1	

10	Washer, 9/16" SAE Flat	F81057-2	2	
11	Spring, .72 X 1.5 X .967" Diameter Stainless Steel Compression	P04282	1	
12	Pin, 1/8" X 1" Cotter	F05012-1	1	
	Pin, Outrigger Pull Painted	S12260-0	1	
13	Pin, 5/16 x 2 1/2" Roll	F05012-47	1	
14	Pin, Outrigger Pull	S12260-0	1	
15	Pin, 3/8 X 2 1/4" Square Wire Lock	014151	2	

8 Bed Frame Assembly

Pivot Bed Rail Assembly

8.6 Pivot Bed Rail Assembly

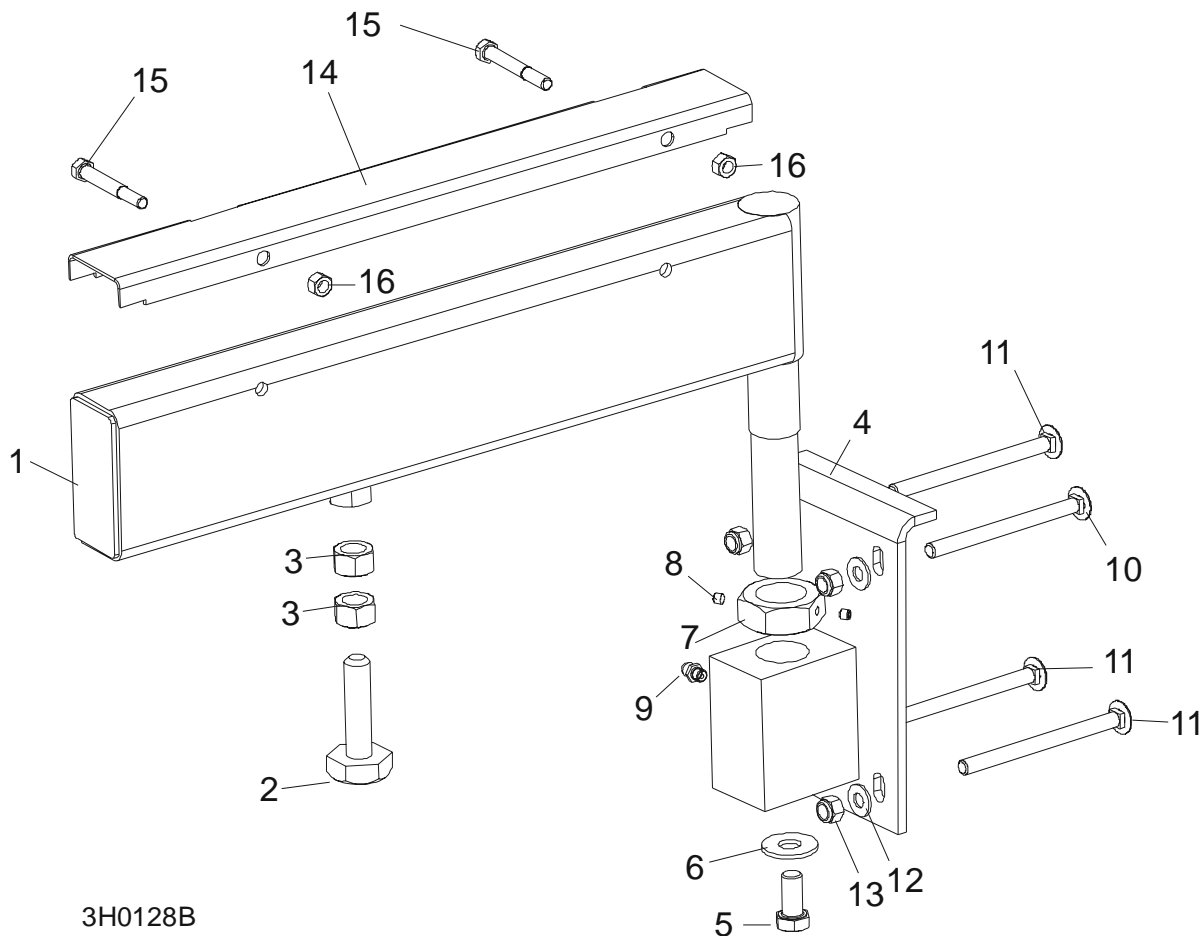

3H0128B

REF	DESCRIPTION (◆ Indicates Parts Available In Assemblies Only)	PART #	QTY.
	PIVOT BED RAIL ASSEMBLY ()	087829	2
	PIVOT BED RAIL ASSEMBLY ()	087855	2
1	Pivot Bed Rail Weldment ()	087852	1
	Pivot Bed Rail Weldment ()	087848	1
	Bolt Assembly, Bed Rail Adjustment		1
2	Bolt, Bed Rail Adjustment	086809	1
3	Nut, 5/8-11 Hex	F81036-1	2
4	Bracket, Pivot Rail Mounting	087841-1	1
5	Bolt, 1/2-13 x 1" Hex Head Grade 2	F81004-31	1
6	Washer, 15 Flat	F05011-52	1
7	Nut, Pivot Rail Adjustment ()	F81036-1	1
	Nut, Pivot Rail Adjustment ()	F81039-2	

8	Screw, 1/4-28 x 1/4" Brass Tip Set	F05005-42	2	
9	Fitting, 3/16" Grease	086280	1	
10	BOLT, 3M10 X 120-8.8 CARRIAGE HEAD	F81003-14	2	
11	BOLT, 3/8-16 X 5" CARRIAGE HEAD	F05007-113	6	
12	WASHER,10.5 FLAT	F81055-1	8	
13	NUT, M16-8 NYLON LOCK	F81036-2	8	
	COVER KIT, PIVOT RAIL STAINLESS STEEL ()	015926	2	
	COVER KIT, PIVOT RAIL STAINLESS STEEL ()	N/A	2	
14	Cover, Stainless Steel Pivot Bed Rail ()	012994	1	
	Cover, Stainless Steel Pivot Bed Rail ()	S13012	1	
15	Bolt, M8x65-5,8 Zinc Hex Head	F81002-3	4	
16	Nut, M8-8-B-Zinc Hex Nylon Lock	F81032-2	4	
	WRENCH, BED RAIL ADJUSTMENT (<i>See Section 8.3</i>)	015970	1	

8 Bed Frame Assembly

Log Side Support Assembly (Manual)

8.7 Log Side Support Assembly (Manual)

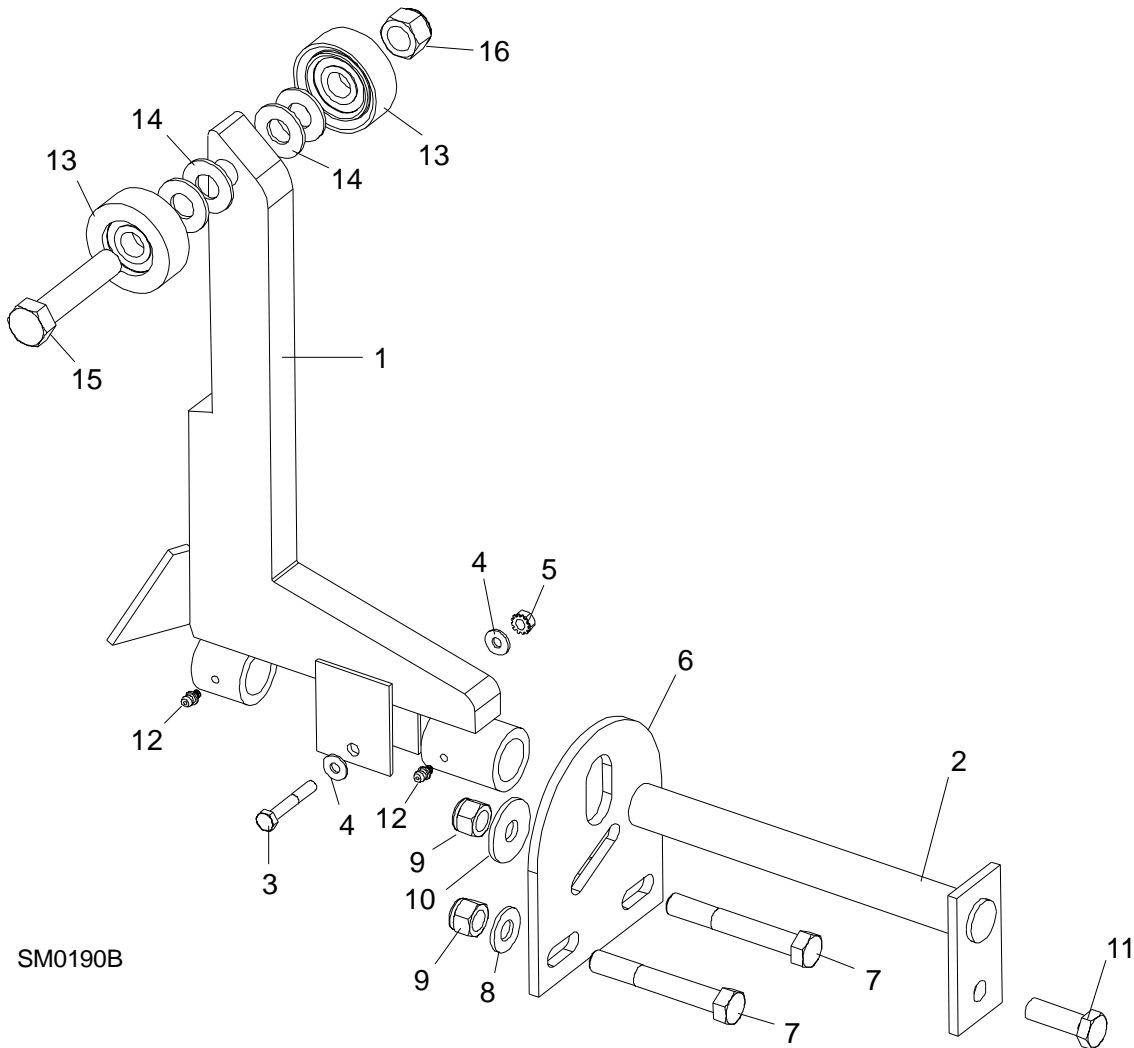

REF	DESCRIPTION (◆ Indicates Parts Available In Assemblies Only)	PART #	QTY.
1	SUPPORT, LOG SIDE	085538	
	MOUNTING KIT, LOG SIDE SUPPORT	K09440	
2	Pin, Log Side Support Pivot	W09238-1	1
3	Bolt, 1/4-20 X 1 1/2" Hex Head Grade 5	F05005-4	1
4	Washer, 7.4 Flat	F81056-11	2
5	Nut, 1/4-20 Self Locking	F05010-9	1
6	Plate, Log Side Support End	S09148	1
7	Bolt, M12 x 90-8.8 Hex Head	F81004-2	2
8	Washer, 13 Flat	F81056-1	2

9	Nut, M12-8 Hex Nylon Lock	F81034-2	3	
10	Washer, .5" x 1.63" x 11" Ga.	086184	1	
11	Bolt, M12 x 35-8.8 Hex Head	F81004-11	1	
12	FITTING, 3/16" GREASE	P04107	2	
	ROLLER KIT, SIDE SUPPORT (OPTIONAL)	015109	4	
13	Roller Assembly, Side Support	015014-1	2	
14	Washer, 17 Flat	F81058-1	4	
15	Bolt, 5/8-11 x 3" Hex Head Grade 5	F05009-37	1	
16	Nut, 5/8-11 Nylon Lock	F05010-34	1	
	Instruction Sheet, Side Support Roller	015109-526	1	

8

Bed Frame Assembly

Tie Down Chain Assembly

8.8 Tie Down Chain Assembly

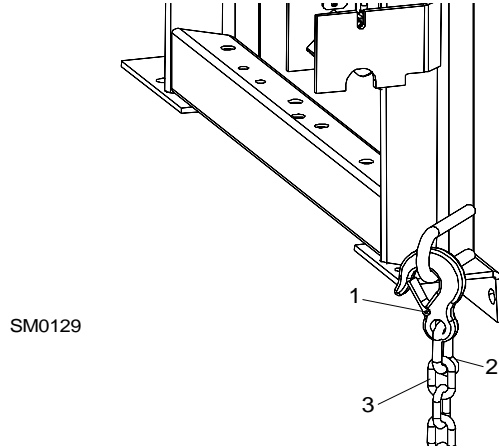

REF	DESCRIPTION (◆ Indicates Parts Available In Assemblies Only)	PART #	QTY.	
	CHAIN ASSEMBLY, TIE DOWN	A04376	1	
1	Hook, 5/8" Safety Chain	P12075	1	◆
2	Cold Shut, 3/8" Plain	P04772-2	1	◆
3	Chain, N-10 x 35 Unplated	R80558	.28 m	◆

8.9 Saw Head Rest Pin Assembly

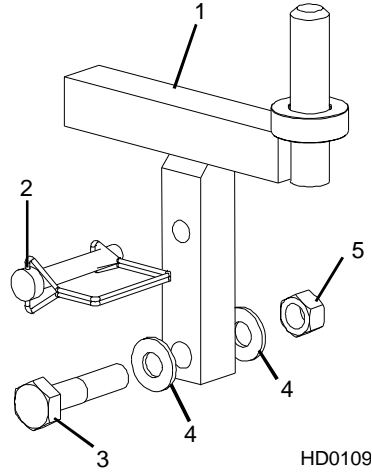

HD0109

REF	DESCRIPTION (◆ Indicates Parts Available In Assemblies Only)	PART #	QTY.	
1	PIN, SAW HEAD REST	085949	1	
2	PIN, 3/8" X 2 1/4" SNAP RETAINER	014151	1	
3	BOLT, M12 X 60-8.8 HEX HEAD GRADE 5	F81004-5	1	
4	WASHER, 13 SAE FLAT	F81056-1	2	
5	NUT, 1/2-13 HEX LOCK	F05010-3	1	

8 Bed Frame Assembly

Bed Frame Decals

8.10 Bed Frame Decals

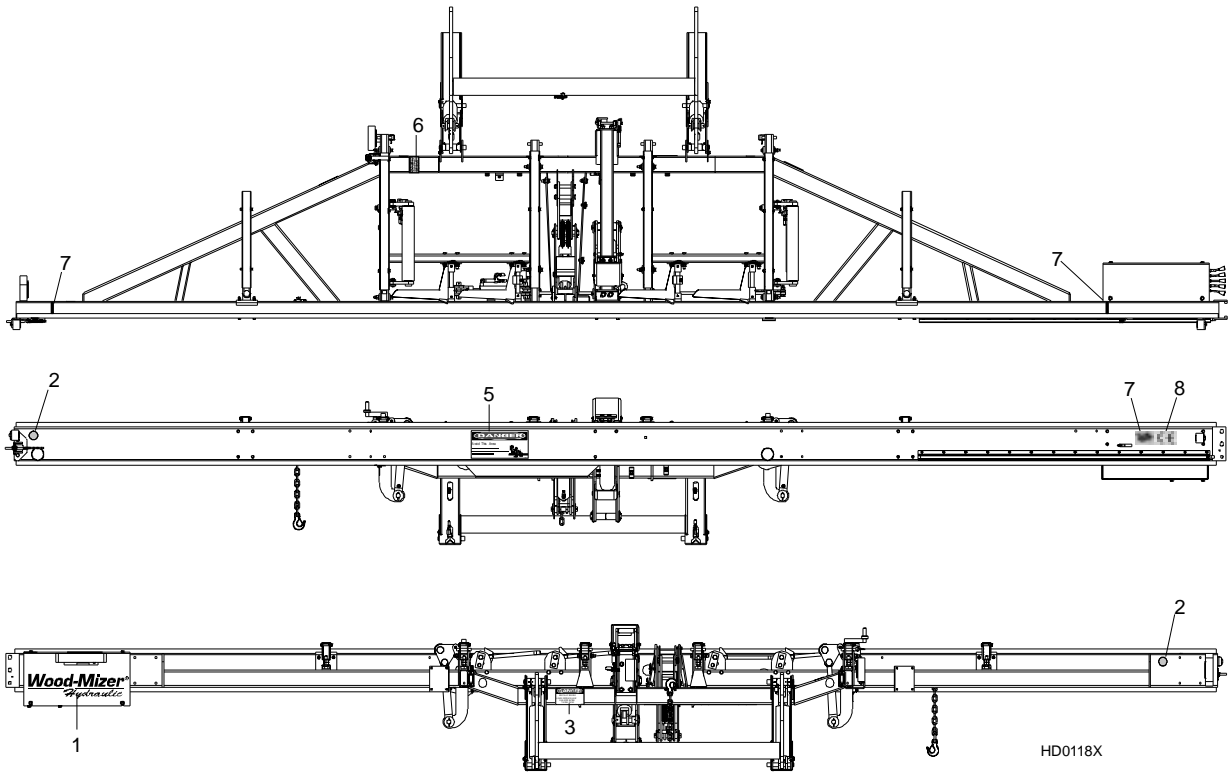

REF	DESCRIPTION (◆ Indicates Parts Available In Assemblies Only)	PART #	QTY.
6	DECAL, AMBER REFLECTIVE 2" ROUND	P07453	2
7	DECAL, KEEP AWAY DANGER	S09851	1
8	DECAL, PINCH POINT DANGER	P10287	1
9	DECAL, SAW HEAD REST CAUTION	S12581	1
10	DECAL, LOG LIMIT STRIPE	S12051	2
11	DECAL, GS SAFETY CERTIFICATION, SMALL	P85072	1
12	DECAL, CE CERTIFIED SAWMILL, SMALL	P85070	1

SECTION 9 HYDRAULIC SYSTEM

9.1 Hydraulic Hoses LT60AHD/70AHD

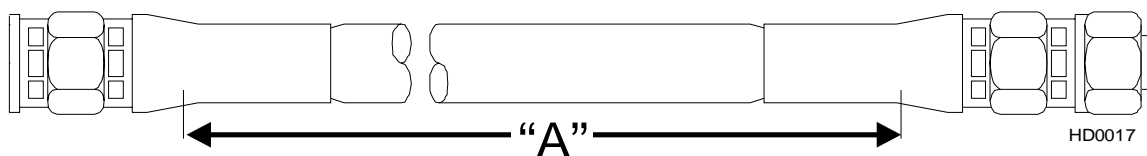

COLOR	LENGTH "A"	DESCRIPTION (◆ Indicates Parts Available In Assemblies Only)	PART #	QTY.	
None	9"	3/8" HYDRAULIC PUMP TO VALVE	014716	1	
Plain	14"	LOG TURNER CYLINDER BASE	P12533	1	
Orange	27"	LOG TURNER CYLINDER TOP	P12535	1	
Yellow	95"	FRONT TOE BOARD TOP (LT30HD)	P12540	1	
	117"	FRONT TOE BOARD TOP (LT40HD)	P12542	1	
Gray	95"	FRONT TOE BOARD BASE (LT30HD)	P12540	1	
	117"	FRONT TOE BOARD BASE (LT40HD)	P12542	1	
Plain	167"	SIDE SUPPORT CYLINDER TOP (LT30HD)	014786	1	
	189"	SIDE SUPPORT CYLINDER TOP (LT40HD)	014790	1	
Pink	159"	SIDE SUPPORT CYLINDER BASE (LT30HD)	P12547	1	
	181"	SIDE SUPPORT CYLINDER BASE (LT40HD)	014788	1	
White	142"	CLAMP CYLINDER TOP (LT30HD)	P12544	1	
	164"	CLAMP CYLINDER TOP (LT40HD)	P12548	1	
Dark Orange	135"	CLAMP CYLINDER BASE (LT30HD)	P12543	1	
	157"	CLAMP CYLINDER BASE (LT40HD)	P12546	1	
Purple	194"	REAR TOE BOARD TOP (LT30HD)	015692	1	
	216"	REAR TOE BOARD TOP (LT40HD)	014793	1	
Black	194"	REAR TOE BOARD BASE (LT30HD)	015692	1	
	216"	REAR TOE BOARD BASE (LT40HD)	014793	1	
Green	54"	LOADING ARM BRANCH TOP	014781	2	
Yellow	57"	LOADING ARM BRANCH BASE	014782	2	
Blue	163"	LOADING ARM CYLINDER TOP (LT30HD)	014785	1	
	185"	LOADING ARM CYLINDER TOP (LT40HD)	014789	1	
Red	163"	LOADING ARM CYLINDER BOTTOM (LT30HD)	014785	1	
	185"	LOADING ARM CYLINDER BOTTOM (LT40HD)	014789	1	
Green	174"	1/4" CLAMP UP (LT30HD)	014787	1	
	196"	1/4" CLAMP UP (LT40HD)	014791	1	
Yellow	174"	1/4" CLAMP DOWN (LT30HD)	014787	1	
	196"	1/4" CLAMP DOWN (LT40HD)	014791	1	

9.2 Hydraulic Control Box LT60AHD/70AHD

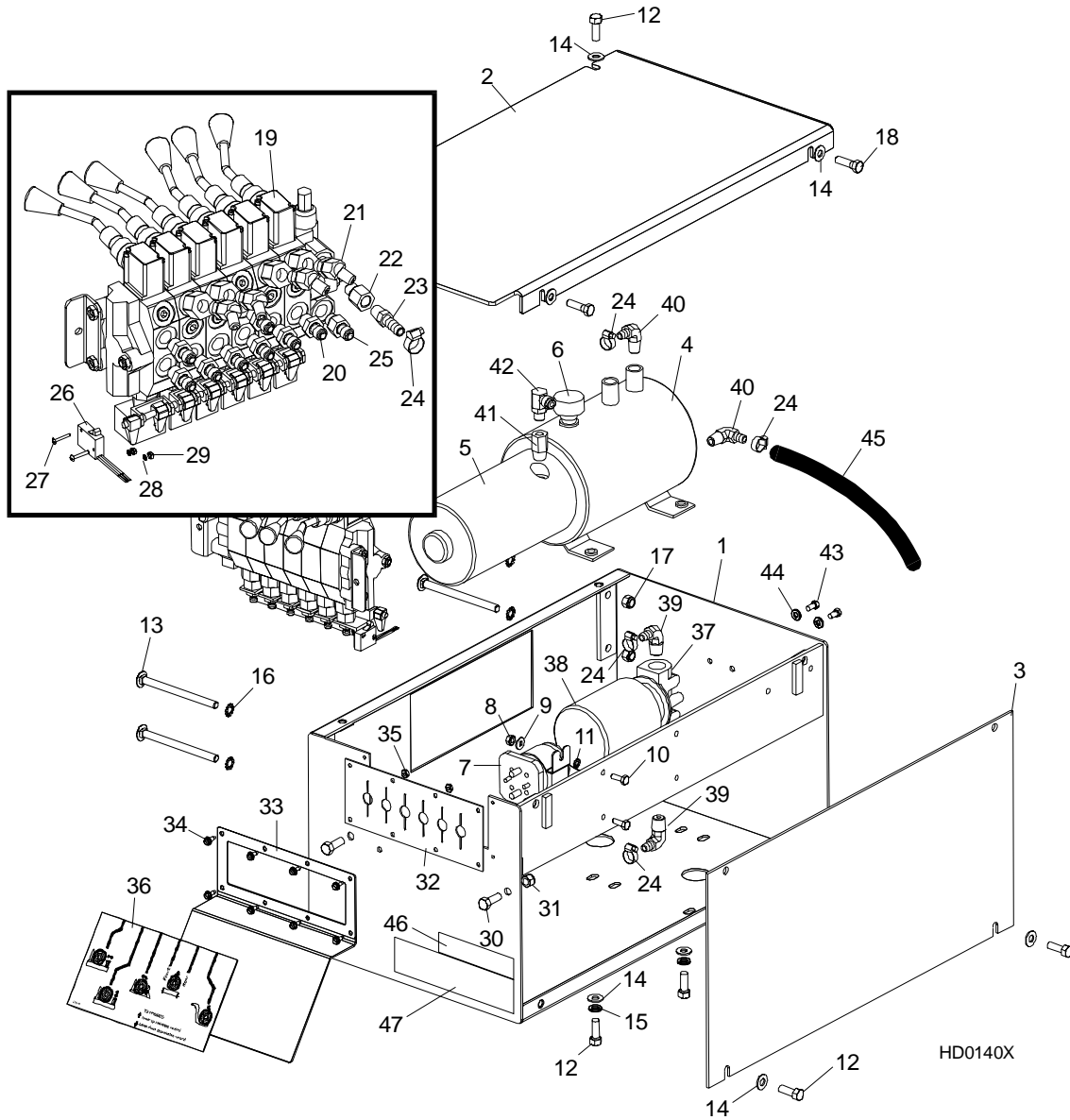

REF	DESCRIPTION (◆ Indicates Parts Available In Assemblies Only)	PART #	QTY.
1	BOX WELDMENT, SUPER HYDRAULIC PUMP HOUSING	015027-1	1
2	COVER, SUPER HYDRAULIC PUMP HOUSING TOP	015228	1
3	COVER, SUPER HYDRAULIC PUMP HOUSING SIDE	015227	1
4	PUMP W/MOTOR, HYDRAULIC #M-300-0230	P12701	1
5	Motor, 12 VDC Hydraulic Pump #08058	P09955	1

9

Hydraulic System*Hydraulic Control Box LT60AHD/70AHD*

	Brush Kit, 4-Valve Hydraulic Pump Motor #08658	P09585	1	
	Bearing, Base Motor #02318	P12513	1	
6	Cap, Hydraulic Pump Vented Fill #03171	P12817	1	
	O-Ring, Hydraulic Pump/Reservoir #02352	P10198	1	
	Seal, Hydraulic Pump/Motor #02330	P10315	1	
7	SOLENOID, 200A 12V SPST HYDRAULIC PUMP MOTOR	015470	1	
8	NUT, 1/4-20 SELF-LOCKING HEX	F05010-9	2	
9	WASHER, 1/4" SAE FLAT	F05011-11	2	
10	BOLT, #1/4-20 X 3/4" HEX HEAD FULL THREAD	F05005-1	2	
11	WASHER, 1/4" EXTERIOR STAR LOCK	F05011-37	2	
	FLUID, 1-QUART DEXRON III HYDRAULIC	P12742	8.5 l	
	FLUID, 1-GALLON EXXON UNIVIS J26 HYDRAULIC	P12823	8.5 l	
	FLUID, 1-GALLON EXXON UNIVIS P13 HYDRAULIC	P12822	8.5 l	
12	BOLT, 3/8-16 X 1" HEX HEAD GRADE 5	F05007-7	8	
13	BOLT, 3/8-16 X 5" CARRIAGE HEAD	F05007-113	4	
14	WASHER, 3/8" SAE FLAT	F05011-3	10	
15	WASHER, 3/8" SPLIT LOCK	F05011-4	4	
16	WASHER, 3/8" EXTERNAL STAR LOCK	F05011-36	4	
17	NUT, 3/8-16 HEX NYLON LOCK	F05010-10	4	
18	BOLT, 3/8-16 X 1 1/4" HEX HEAD	F05007-2	2	
19	VALVE, HYDRAULIC 6 SECTION (<i>See Form 575</i> FOR VALVE SERVICE PARTS)	015260	1	
20	FITTING, 3/8" O-RING - 1/4" JIC	P26284	8	
21	FITTING, #6 SAE - 1/4" JIC 45° ELBOW	015488	4	
22	FITTING, #6 SAE MALE - 1/4" NPT FEMALE	014686	1	
23	FITTING, 1/4" NPT X 3/8" HOSE BARB	014685	1	
24	CLAMP, 11/16" HOSE	P12739	5	
25	FITTING, 3/8" O-RING - 1/4" JIC	P26284	1	
26	SWITCH, HYDRAULIC VALVE ELECTRIC	024198	1	
27	SCREW, #4-40 X 3/4" SLOTTED	F05004-13	2	
28	WASHER, #4 SPLIT LOCK	F05011-21	2	
29	NUT, #4-40 HEX	F05010-43	2	
30	BOLT, 3/8-16 X 1" HEX HEAD	F05007-7	2	
31	NUT, 3/8-16 HEX NYLON LOCK	F05010-10	2	
32	SEAL, RUBBER VALVE HANDLE	015079	1	
33	PLATE, VALVE HANDLE DECAL	015078	1	
34	SCREW, #10-24 X 1/2 SLOTTED HEX SELF-TAPPING	F05015-7	8	
35	NUT, #10-24 SELF-LOCKING HEX	F05010-14	2	
36	DECAL, 1997 HYDRAULIC CONTROL BOX	015364	1	
37	MANIFOLD, HYDRAULIC CARTRIDGE FILTER	P22683	1	
38	Filter, S28 Hydraulic Cartridge	P20301	1	
39	FITTING, #6-8 (1/2" NPT) - 3/8" HOSE BARB ELBOW	P12707	2	
40	FITTING, #6-6 (3/8" NPT) - 3/8" HOSE BARB ELBOW	P12708	2	
41	FITTING, 3/8" NPT MALE - 1/4" NPT FEMALE	015490	1	

42	FITTING, 1/4" NPT - 1/4" JIC ELBOW	P09142	1	
43	BOLT, 1/4-20 X 1/2" HEX HEAD	F05005-15	2	
44	WASHER, 1/4" SPLIT LOCK	F05011-14	2	
45	HOSE, 3/8" LOW PRESSURE HYDRAULIC	R01892-1	A/R	
	GROUNDING ASSEMBLY, HYDRAULIC PUMP	N/A	1	
	Bolt, 3/8-16 x 1/2" Hex Head Grade 5	F05004-124	1	
	Cable, 1AWG SO Welding	R01971	.39 m	
	Terminal, 5/16 1-2Ga Ring NI Loose	F05092-16	2	
	Washer, 3/8" Star External	F05011-36	2	
46	DECAL, HYDRAULIC WORKING PRESSURE	P85069	1	
47	DECAL, HYDRAULIC FLUID	P85068	1	

9

Hydraulic System Hydraulic Power Supply Strip

9.3 Hydraulic Power Supply Strip

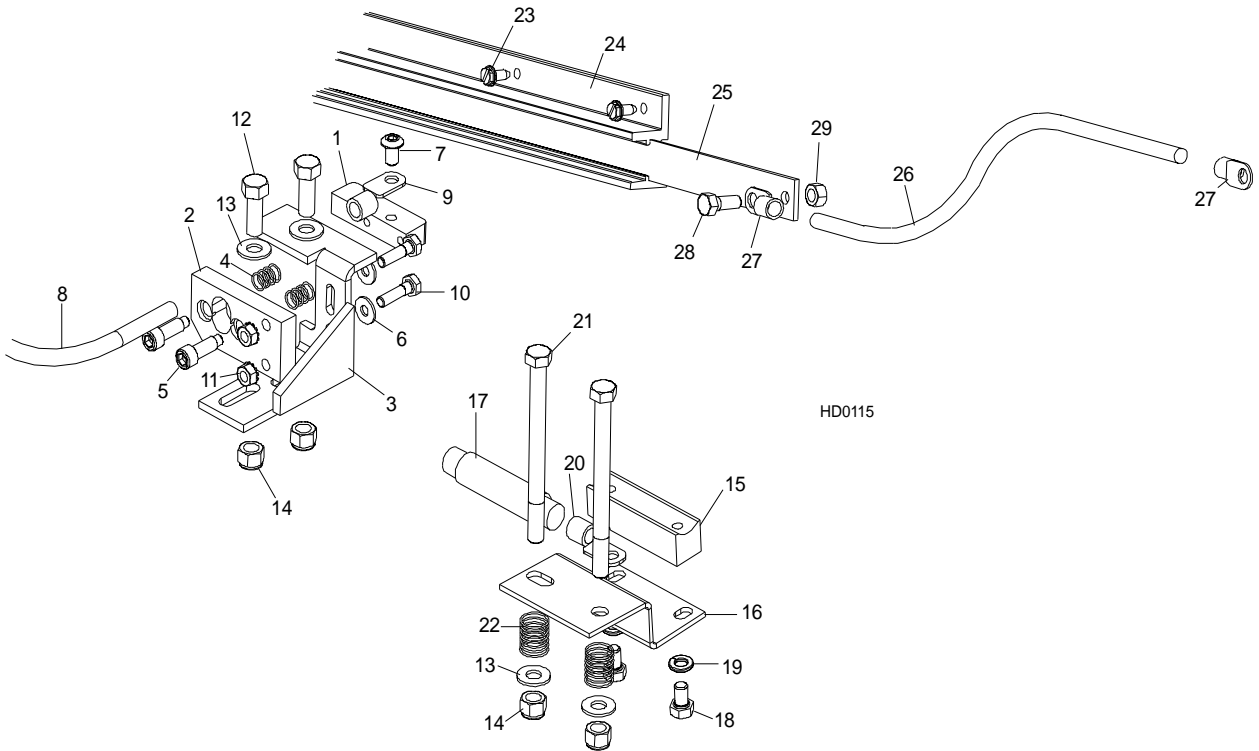

REF	DESCRIPTION (◆ Indicates Parts Available In Assemblies Only)	PART #	QTY.	
	CONTACT KIT, HYDRAULIC 6' POWER SUPPLY	A12042-N	1	
	Contact Hardware Kit	A10073-N	1	◆
	Contact Assembly, Hydraulic Power Supply (Positive)	085968	1	
1	Contact, Hydraulic Power Supply (Positive)	015253	1	
2	Insulator, Positive Contact	S10072	1	
3	Bracket, Positive Contact Mounting	086380-1	1	
4	Spring, Positive Contact	P10077	2	
5	Bolt, 5/16" X 3/4" Shoulder (1/4-20 Thread)	F05006-44	2	
6	Washer, 7.4 Flat	F81056-11	2	
7	Bolt, 5/16-18 x 1/2" Socket Button Head	F05006-20	1	
	Cable Assy, Hydraulic Positive Contact	015885	1	
8	Cable, #1 Weld	R01948	0.75m	◆
9	Terminal, 35 Ring #2 Gauge	F81066-3	2	
10	Bolt, 1/4-20 X 1" Hex Head Grade 2	F05005-38	2	
11	Nut, 1/4-20 Hex Self-Locking	F05010-9	2	
12	Bolt, 3/8-16 X 1" Hex Head Grade 5	F05007-87	2	

13	Washer, 10.5 Flat	F81055-1	4	
14	Nut, 3/8-16 Hex Nylon Lock	F05010-10	4	
	Contact Assembly, Hydraulic Power Supply (Ground)	A10066	1	
15	Contact, Hydraulic Power Supply (Ground)	015264	1	
16	Bracket, Ground Contact Mounting	015265	1	
17	Cable, #1 Weld	R01948	.63m	◆
18	Bolt, 5/16-18 X 1/2" Hex Head Grade 5	F05006-15	2	
19	Washer, 8.2 Split Lock	F81054-4	2	
20	Terminal, 35 Ring #2 Gauge	F81066-3	1	
21	Bolt, 3/8-16 X 4 1/2" Hex Head Grade 2	F05007-35	2	
22	Spring, Ground Contact	P04282	2	
23	Screw, 1/4-20 X 1/2" Slotted Hex Head	F05015-1	14	
24	Housing, 6' Contact Strip	P11976	1	
25	Strip, 6' Contact	S10075	1	◆
26	Cable, #2 Weld	R80583-21		◆
27	Terminal, 35 Ring #2 Gauge	F81066-3		
28	Bolt, 5/16-18 X 3/4" Hex Head Black Nylon	F05006-45	1	
29	Nut, 5/16-18 Hex Black Nylon	F05010-86	1	
	Tube, 5/8" Heat Shrink	R01950-5	m	◆
	Grommet, 5/8" Wire	P04137		

9

Hydraulic System Hydraulic Log Loader

9.4 Hydraulic Log Loader

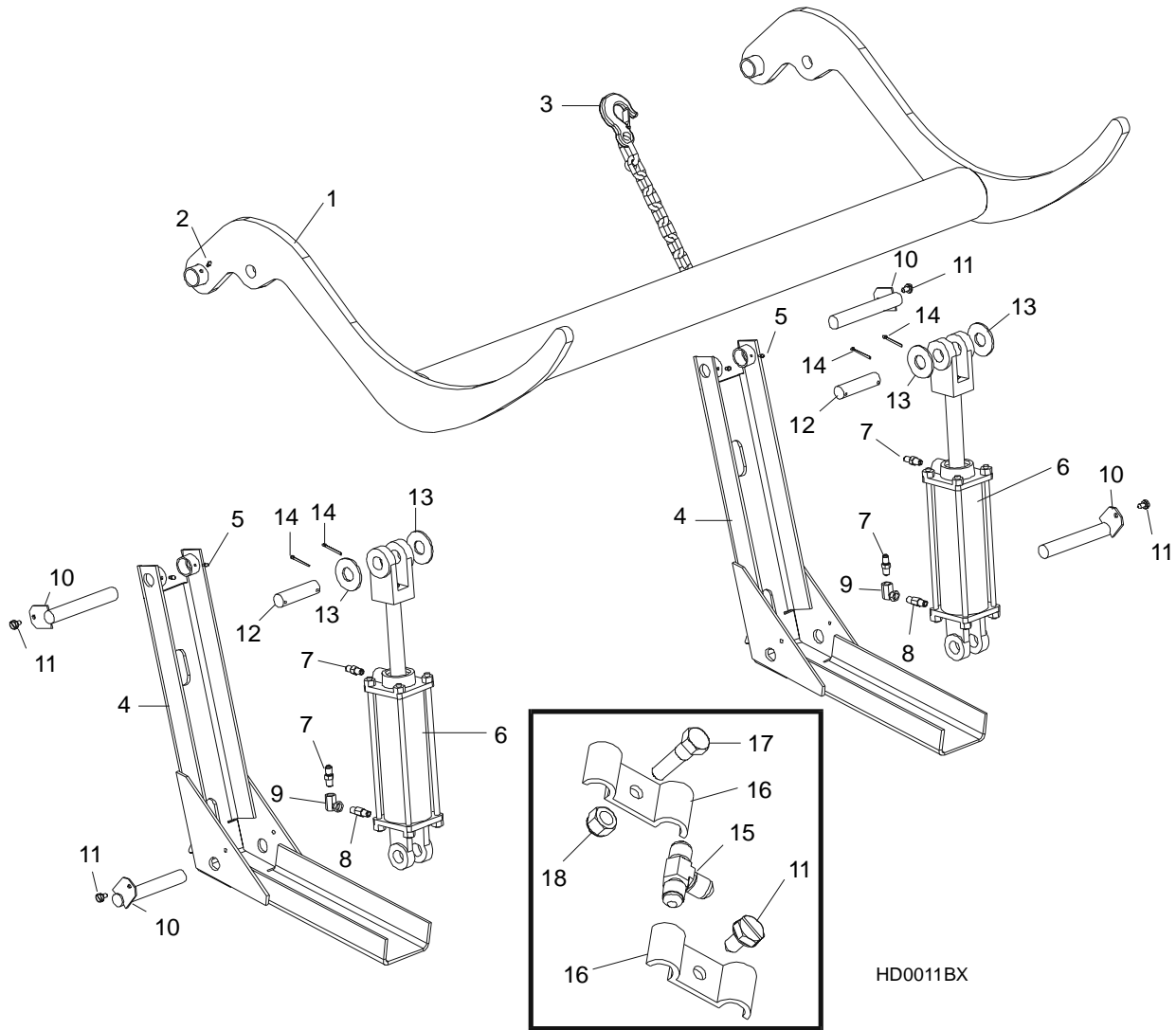

REF	DESCRIPTION (◆ Indicates Parts Available In Assemblies Only)	PART #	QTY.
	LOADER KIT, HYDRAULIC LOG	086534	1
1	Arm, Hydraulic Log Loading	086535-1	1
2	Fitting, 3/16" Grease	P04107	2
3	Chain, Hydraulic Log Loader Safety	A04376	1
4	Channel, Hydraulic Log Loading Foot	W09444	2
5	Fitting, 3/16" Grease	P04107	2
6	Cylinder hydr.CJ-S95-16-70/32/203	088680	1
	Seal Kit, 8" x 3" Hydraulic Cylinder	P12956	1
	Fitting Kit, 1/4NPT 4.0GPM Velocity Fuse	015832	1

7	Fitting, 1/4NPT 4.0GPM Velocity Fuse	015750	2	◆
	Instruction Sheet, Velocity Fuse Replacement	015832-255	1	
8	Fitting, 0455x4x4 90° Swivel Elbow	P12199	1	
9	Pin, Loading Arm Mount	W09446-1	4	
10	Screw, 5/16-18 X 3/4" Self Tapping	F05015-30	8	
11	Pin, Loading Arm Cylinder Mount	086979-1	2	
12	Washer, 28 Flat	F81061-1	4	
13	Pin, 3/16" X 1 1/2" Cotter	F05012-23	4	
14	Bolt, 5/16-18 X 1" Hex Head Grade 2	F05006-1	2	
15	Nut, 5/16-18 Hex Nylon Lock	F05010-58	2	

9

Hydraulic System Hydraulic Log Turner

9.5 Hydraulic Log Turner

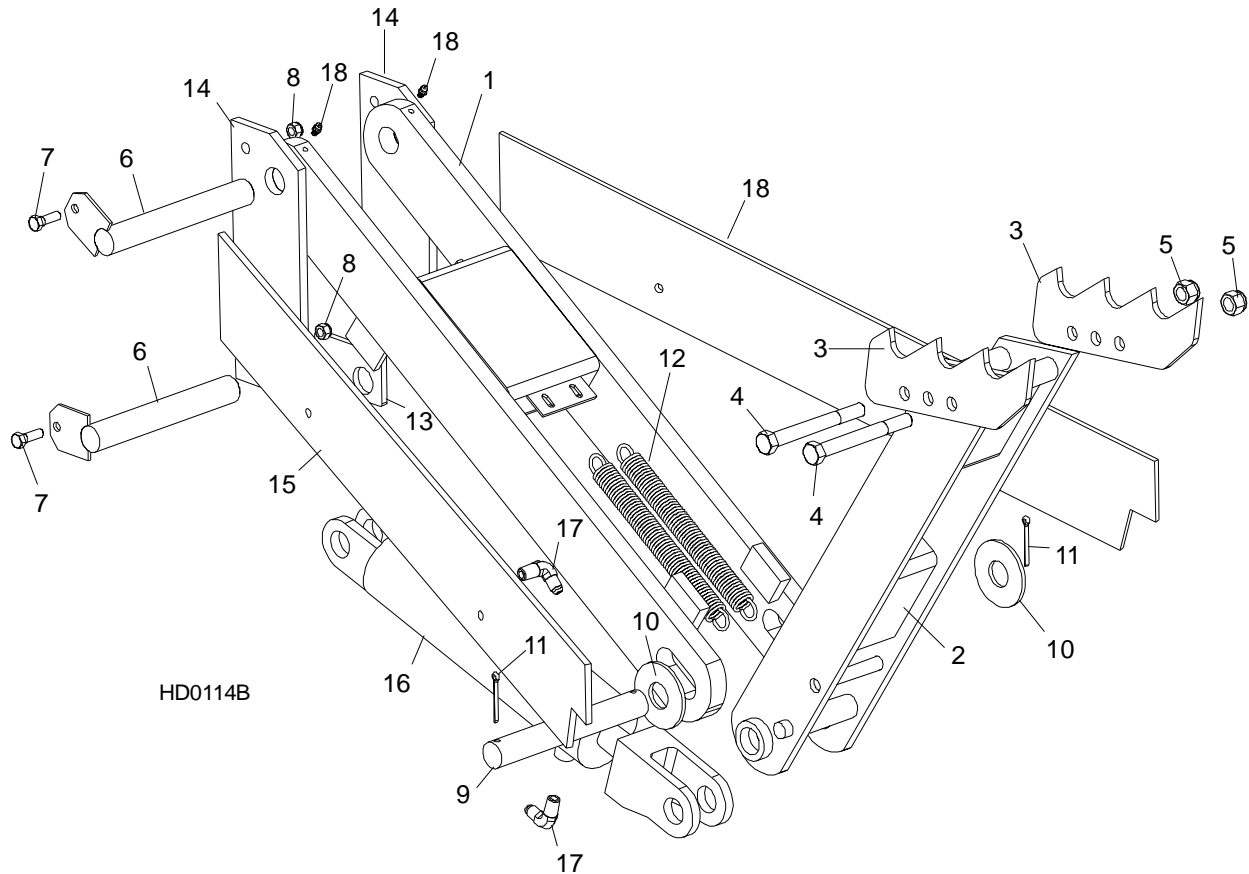

REF	DESCRIPTION (◆ Indicates Parts Available In Assemblies Only)	PART #	QTY.
1	ARM, HYDRAULIC LOG TURNER LINK	015231	1
2	ARM, HYDRAULIC LOG TURNER PAINTED	015233	1
3	CLAW, HYDRAULIC LOG TURNER	014675	
4	BOLT, M12 X 25-8.8 HEX HEAD	F81004-34	2
5	NUT, M12-8 HEX LOCK	F81034-2	2
6	PIN, LOG TURNER MOUNT	015085-1	2
7	BOLT, 5/16-18 X 1" HEX HEAD GRADE 2	F05006-1	2
8	NUT, 5/16-18 HEX LOCK	F05010-6	2
9	PIN, LOG TURNER PIVOT	S09246	1
10	WASHER, 28 FLAT	F81061-1	2
11	PIN, 3/16" X 1 1/2" COTTER	F05012-23	2
12	SPRING, HYDRAULIC LOG TURNER	015718	2
13	PLATE, LOG TURNER CYLINDER MOUNT	S09155	1
14	PLATE, LOG TURNER MOUNT	085884	2
15	PLATE, LOG TURNER BRACE	S09605-0	2

16	Cylinder hydr.CJ-S305-16-63/28/203	088679	1	
	Seal Kit, 8" x 2 1/2" Hydraulic Cylinder	P12955	1	
17	FITTING, 3/16" GREASE	P04107	2	

9.6 Hydraulic Log Side Supports

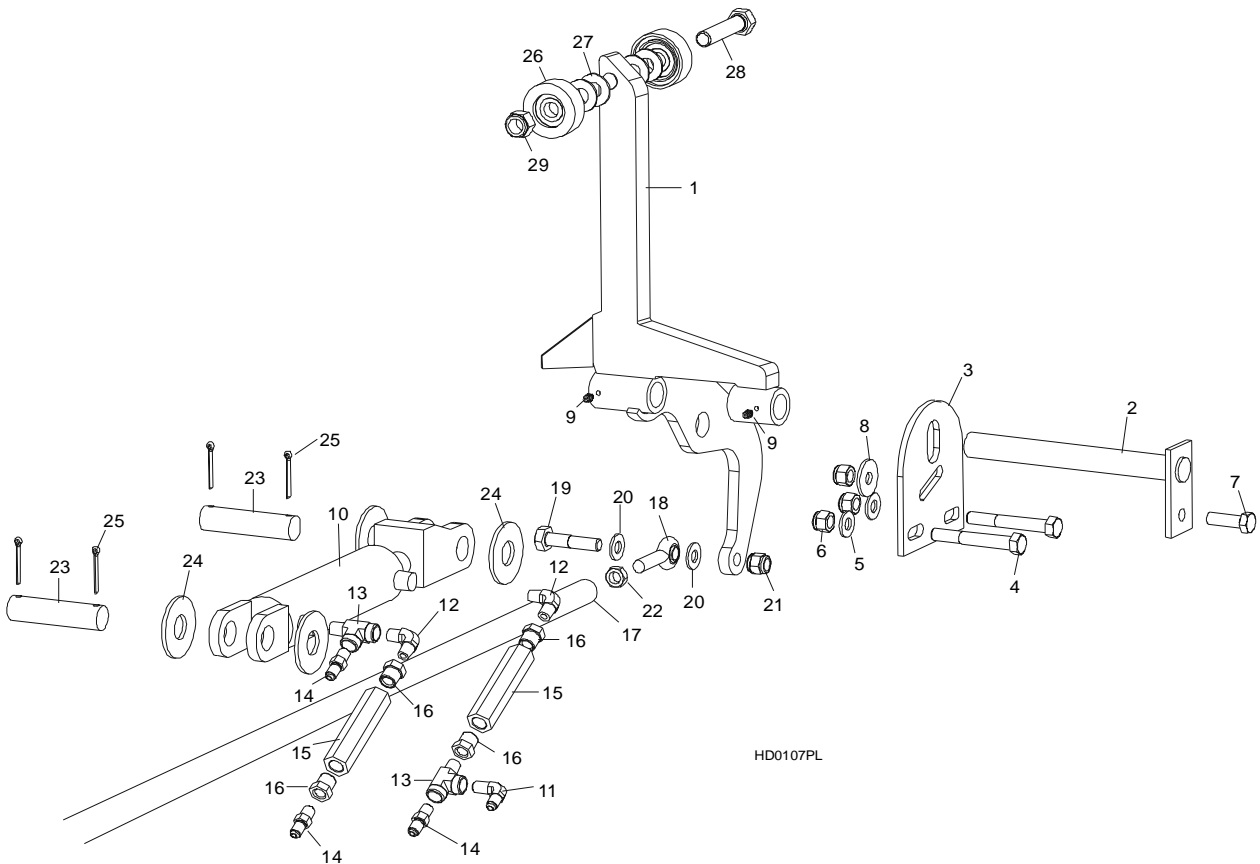

REF	DESCRIPTION (◆ Indicates Parts Available In Assemblies Only)	PART #	QTY.	
1	SUPPORT, HYDRAULIC LOG SIDE	085578	2	
2	PIN, LOG SIDE SUPPORT PIVOT	W09238	1	
3	PLATE, LOG SIDE SUPPORT END	S09148	1	
4	BOLT, M12 X 40-8.8 HEX HEAD	F81004-4	2	
5	WASHER, 13 FLAT	F81056-1	2	
6	NUT, M12-8 HEX NYLON LOCK	F81034-2	3	
7	BOLT, M12 X 40-8.8 HEX HEAD GRADE 5	F81004-4	1	
8	WASHER, 45/13	086184	1	
9	FITTING, 3/16" GREASE	P04107	4	
10	Cylinder hydr. CJ-S270-16-50/28/152	088678	1	◆
	Seal Kit, 6" x 2" Hydraulic Cylinder	P12954	1	
11	Fitting, C3529x4 90° Pipe	P09140	2	
12	Fitting, C3759x4 Male 'T'	P09141	2	
13	Valve, Hydraulic Sequence	015484	2	

14	Fitting, 3/8" NPT - 1/4" NPT Reducer	015490	4	
15	ROD, HYDRAULIC SIDE SUPPORT LINK	087037-1	1	
16	END, RIGHT ROD	087035	1	
	END, LEFT ROD	087036	1	
17	BOLT, M12 X 60-8.8 HEX HEAD	F81004-5	2	
18	WASHER, 7.4 SAE FLAT	F81056-1	4	
19	NUT, M12-8 HEX NYLON LOCK	F81034-2	2	
20	NUT, M12-04-A RIGHT HEX JAM	F81034-6	1	
	NUT, M12-04-A LEFT HEX JAM	F81034-7	1	
21	PIN, CYLINDER MOUNT	086979-1	2	
22	WASHER, 28 SAE FLAT	F81061-1	4	
23	PIN, 5 X 40 COTTER	F81043-31	4	
	ROLLER KIT, SIDE SUPPORT	015109	2	
24	Roller Assembly, Side Support	015014-1	2	
25	Washer, 17 Flat	F81058-1	4	
26	Bolt, 5/8-11 x 3" Hex Head Grade 5	F05009-37	1	
27	Nut, 5/8-11 Nylon Lock	F05010-34	1	
	Instruction Sheet, Side Support Roller	015109-526	1	

9.7 Hydraulic Log Clamp

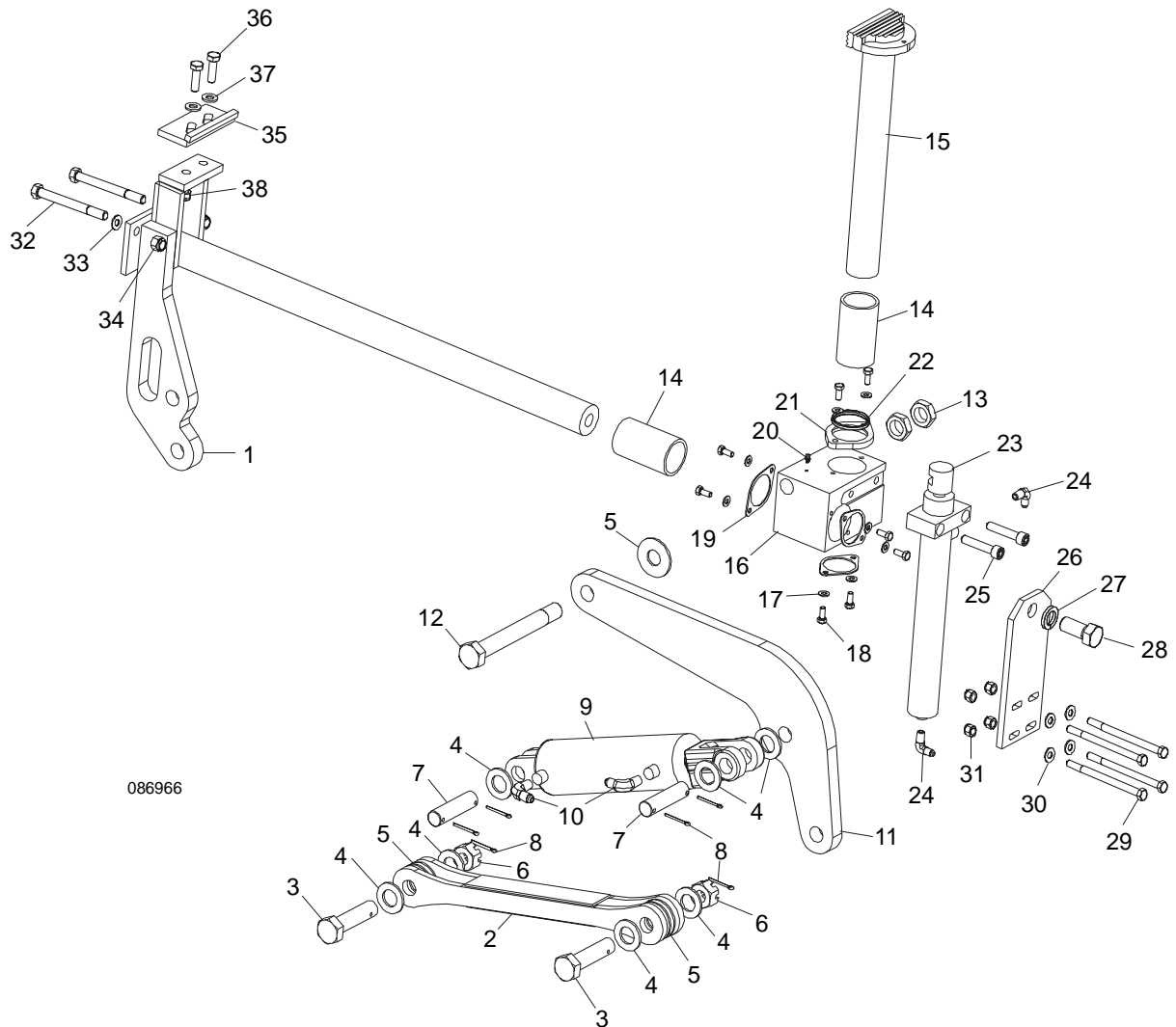

REF	DESCRIPTION (◆ Indicates Parts Available In Assemblies Only)	PART #	QTY.
	CLAMP ASSEMBLY, SUPER HYDRAULIC	088658	1
1	Mount Weldment, Super Clamp Tube	086967-1	1
2	Arm, Clamp Link	086963-1	1
3	Bolt, B 24x95/85 Hex Head Grade 8	F81049-2	1
4	Washer, 25 Flat	F81061-3	8
5	Washer, 25X63 Hardened	088585-1	5
6	Nut, M20-8-B Slotted Hex	F81037-3	2
7	Pin, Cylinder Mount	086979-1	2

8	Pin, 6,3x45 Cotter	F81045-2	6	
9	Cylinder, CJ-S96-16-70/32/178 Hydraulic	088589	1	
10	Fitting, 1/4" NPT - 3/8" JIC Elbow	P09142	2	
11	Link Weldment, Super '99 Clamp	086974-1	1	
12	Bolt, M24x217/39 -8.8-B Hex Head Grade 8	088586-1	1	
13	Nut, M24 -04-B Hex Jam	F81039-3	2	
14	Bushing, Clamp Slide 5040BS	088660	2	
15	Clamp Weldment, Vertical Super	088582-1	1	
16	Block, Vertical Clamp Mount	088591-1	1	
17	Washer, 8.4 Flat	F81054-1	8	
18	Bolt, M8x20-8.8-B Hex Head	F81002-4	8	
19	Spacer, Log Clamp	088887-1	3	
20	Fitting, 3/16" Grease	P04107	1	
21	Spacer, Log Clamp	088887-1	1	
22	Wiper, Up/Down Rod ZZ 50x60x7	088587	1	
23	Cylinder, CJ-S169-16-40/22/254 Hydraulic	088590	1	
24	Fitting, 1/4" NPT - 1/4" JIC Elbow	P09142	2	
25	Screw, M12x55 -8.8-B Socket Head	F81004-23	2	
26	Plate, Super Log Clamp Mount	086975-1	1	
27	Washer, Z 22,5 Split Lock	F81059-4	1	
28	Bolt, M22x1,5x40 -8.8-B Hex Head Grade 5	F81009-1	1	
29	Bolt, M10 x 125-8.8 Hex Head	F81003-18	4	
30	Washer, 10.5 Flat	F81055-1	4	
31	Nut, M10-8-B Hex Nylon Lock	F81033-1	4	
32	Bolt, M10 x 140-8.8 Hex Head	F81004-37	2	
33	Washer, 13 Flat	F81056-1	2	
34	Nut, M12-8 Hex Nylon Lock	F81034-1	2	
	CLAMP STOP KIT, HYDRAULIC LOG	K09485	1	
35	Plate, Clamp Stop	086980-1	1	
36	Bolt, M12 x 40-8.8 Hex Head	F81004-4	2	
37	Washer, 13 Flat	F81056-1	2	
38	Nut, M12-8 Hex Nylon Lock	F81034-2	2	

9

Hydraulic System Hydraulic Toe Board

9.8 Hydraulic Toe Board

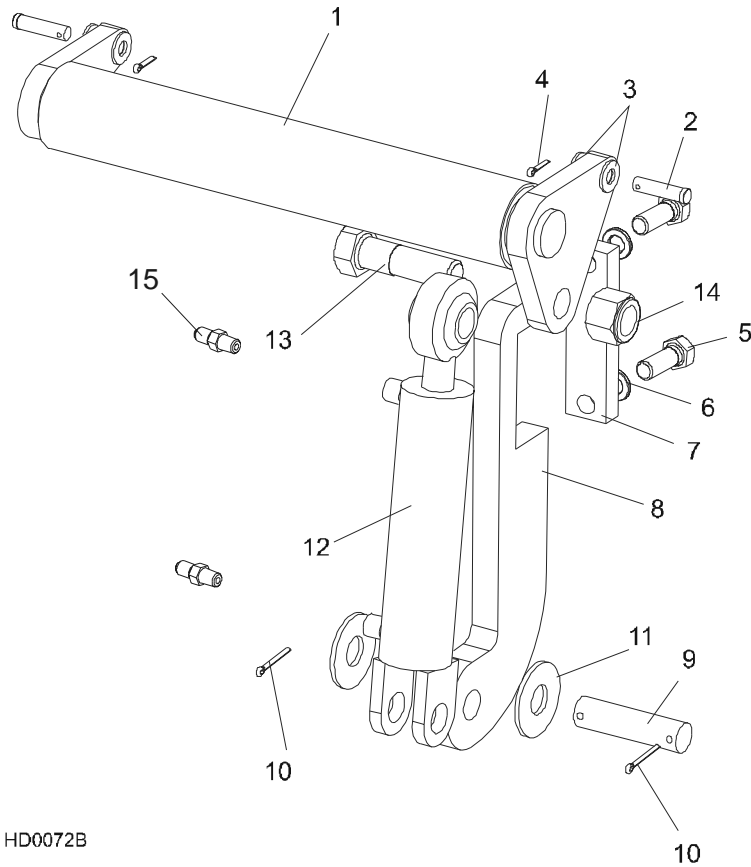

HD0072B

REF	DESCRIPTION (◆ Indicates Parts Available In Assemblies Only)	PART #	QTY.
1	TOE BOARD WELDMENT, HYDRAULIC	086253-1	2
2	PIN, 1/2-1 3/4 CLEVIS	F05012-82	4
3	WASHER, 13 SAE FLAT	F81056-1	8
4	PIN, S-ZN 2.5 X 20 COTTER	F81043-1	4
5	BOLT, 5/8-11 X 1 3/4" HEX HEAD	F05009-33	4
6	WASHER, 17 SPLIT LOCK	F81058-2	4
7	PLATE, HYDRAULIC TOEBOARD MOUNT	S13023-1	2
8	BRACKET, HYDRAULIC TOEBOARD MOUNT	087729	2
9	PIN, CYLINDER MOUNT	S09251	2
10	PIN, 3/16" X 1 1/2" COTTER	F05012-23	4
11	WASHER, 1" SAE FLAT	F05011-28	4
12	CYLINDER HYDR.CJ-S170-16-40/25/152	088681	2
	Seal Kit, 1 1/2" x 6" Hydraulic Cylinder	014547	1
13	BOLT, 1-8 X 3 1/4" HEX HEAD GRADE 5	F05009-51	2
14	NUT, 1-8 HEX NYLON LOCK	F05010-109	2
15	FITTING, 90° MALE ELBOW	P09143	4