

# Wood-Mizer<sup>®</sup> Sawmill

## Parts Manual

---

**LT60 Super**  
**LT70 Super**

**rev. A3.03**  
**rev. A3.03**



**Safety is our #1 concern!** Read and understand all safety information and instructions before operating, setting up or maintaining this machine.

*May 2002*

*Form #1050*

# Table of Contents

# Section-Page

<b>SECTION 1</b>	<b>GENERAL INFORMATION</b>	<b>1-1</b>
1.1	How To Use The Parts List .....	1-1
1.2	Sample Assembly .....	1-1
<b>SECTION 2</b>	<b>BLADE GUIDE ROLLERS &amp; ARM</b>	<b>2-1</b>
2.1	Blade Guide Assembly, Idle Side .....	2-1
2.2	Blade Guide Assembly, Drive Side .....	2-3
2.3	Blade Guide Arm Drive Assembly.....	2-5
<b>SECTION 3</b>	<b>BLADE WHEELS &amp; TENSIONER</b>	<b>3-1</b>
3.1	Blade Drive Assembly.....	3-1
3.2	Idle Blade Wheel Assembly .....	3-3
3.3	Blade Tensioner Assembly.....	3-5
3.4	Sawdust Flow Guide.....	3-7
<b>SECTION 4</b>	<b>SAW HEAD</b>	<b>4-1</b>
4.1	Middle Throat Screw .....	4-1
4.2	Drive Belt Tensioner .....	4-2
4.3	Board Return Assembly .....	4-3
4.4	Water Lube Assembly .....	4-4
4.5	Saw Head Decals.....	4-5
4.6	Blade Housing Covers.....	4-6
4.7	Sawdust Chute.....	4-7
<b>SECTION 5</b>	<b>CONTROL &amp; BATTERY BOXES</b>	<b>5-1</b>
5.1	Control Assembly (Gas/Diesel).....	5-1
5.2	Drum Switches .....	5-3
5.3	Circuit Breakers.....	5-6
<b>SECTION 6</b>	<b>UP/DOWN SYSTEM</b>	<b>6-1</b>
6.1	Up/Down Rollers & Covers .....	6-1
6.2	Blade Height Scale .....	6-3
6.3	Up/Down Chain & Sprockets.....	6-5
6.4	Up/Down Drive Assembly .....	6-7
<b>SECTION 7</b>	<b>FEED SYSTEM &amp; TRACK ROLLERS</b>	<b>7-1</b>
7.1	Upper Track Rollers And Wipers.....	7-1
7.2	Power Feed Assembly .....	7-3
7.3	Feed Chain/Stop, LT60HD/LT70HD .....	7-4
7.4	Lower Track Rollers.....	7-6

# Table of Contents

# Section-Page

## **SECTION 8      BED FRAME ASSEMBLY**

**8-1**

8.1	Bed Rail Assembly, Front And Rear .....	8-1
8.2	Bed Rail Assembly, Front Middle .....	8-3
8.3	Bed Rail Assembly, Rear Middle .....	8-5
8.4	Leg, Stationary .....	8-7
8.5	Pivot Bed Rail Assembly.....	8-9
8.6	Log Side Support Assembly (Manual) .....	8-11
8.7	Tie Down Chain Assembly .....	8-13
8.8	Saw Head Rest Pin Assembly .....	8-14
8.9	Bed Frame Decals .....	8-15

## **SECTION 9      LOG CLAMP, TURNER, LOADER & TOE BOARDS**

**9-1**

9.1	Manual Log Clamp .....	9-1
9.2	Log Clamp Assembly .....	9-2
9.3	Manual Log Turner.....	9-4
9.4	Manual Toe Board.....	9-6
9.5	Log Loading Ramps .....	9-8

## SECTION 1 GENERAL INFORMATION

### 1.1 How To Use The Parts List

- Use the index above to locate the assembly that contains the part you need.
- Go to the appropriate section and locate the part in the illustration.
- Use the number pointing to the part to locate the correct part number and description in the table.
- Parts shown indented under another part are included with that part.
- Parts marked with a diamond (◆) are only available in the assembly listed above the part.

See the sample table below. Sample Part #A01111 includes part F02222-2 and subassembly A03333. Subassembly A03333 includes part S04444-4 and subassembly K05555. The diamond (◆) indicates that S04444-4 is not available except in subassembly A03333. Subassembly K05555 includes parts M06666 and F07777-77. The diamond (◆) indicates M06666 is not available except in subassembly K05555.

<b>1.2 Sample Assembly</b>				
REF	DESCRIPTION (◆ Indicates Parts Available In Assemblies Only)	PART #	QTY.	
	Sample Assembly, Complete (Includes All Indented Parts Below)	A01111	1	
1	Sample Part	F02222-22	1	
	Sample Subassembly (Includes All Indented Parts Below)	A03333	1	
2	Sample Part (◆ Indicates Part Is Only Available With A03333)	S04444-4	1	◆
	Sample Subassembly (Includes All Indented Parts Below)	K05555	1	
3	Sample Part (◆ Indicates Part Is Only Available With K05555)	M06666	2	◆
4	Sample Part	F07777-77	1	

#### **To Order Parts:**

- From Europe call our European Headquarters and Manufacturing Facility in Kolo, Poland at **+48-63-2626000**. From the continental U.S., call our toll-free Parts hotline at **1-800-448-7881**. Have your customer number, vehicle identification number, and part numbers ready when you call.
- From other international locations, contact the Wood-Mizer distributor in your area for parts.

## SECTION 2 BLADE GUIDE ROLLERS & ARM

### 2.1 Blade Guide Assembly, Idle Side

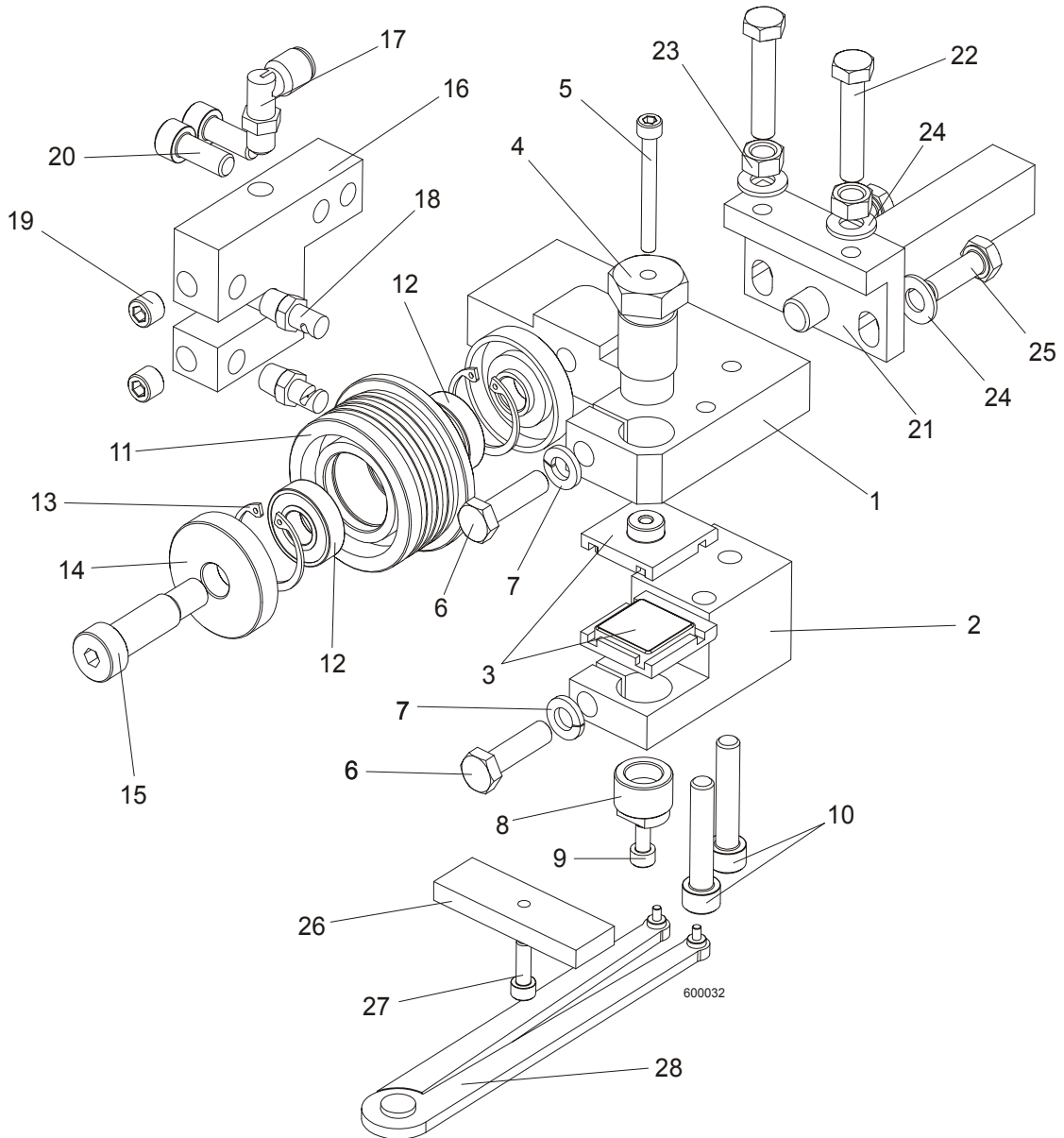



## BLADE GUIDE ROLLERS & ARM

*Blade Guide Assembly, Idle Side*

REF	DESCRIPTION (u Indicates Parts Available In Assemblies Only)	PART#	QTY.	
	<b>BLADE GUIDE ASSEMBLY, IDLE SIDE</b>	090943	1	
1	Block, Blade Guide Mount Zinc-plated	090947-1	1	
2	Block, Lower Ceramic Pad Mount Zinc-plated	090948-1	1	
3	Block assembly, E-Z Glide, Complete	092522	2	
4	Bolt, Upper Pad Adjustment Zinc-plated	089515-1	1	
5	Screw, M5x45 DIN912 A2-70 Hex Socket Head Cap Stainless Steel	F81000-24	1	
6	Bolt, M8x30 DIN933 A2-70 Stainless Steel	F81002-27	2	
7	Washer, 8.2 Split Lock Zinc	F81054-4	2	
8	Screw, Lower Pad Adjuster Zinc-plated	090945-1	1	
9	Screw, M5x10 DIN912 A2-70 Hex Socket Head Cap Stainless Steel	F81000-23	1	
10	Screw, M8x40-8.8 Hex Socket Head Cap Zinc	F81002-29	2	
	Roller, Blade Guide Narrow W/Bearing	088261	1	
11	Roller, Blade Guide Narrow	087889	1	
12	Bearing, 6001 2RSR NACHI	087893	2	
13	Ring, W28 Inside Retaining	F81090-9	2	
14	Washer, Blade Guide Roller Spacer Zinc-plated	087891-1	2	
15	Screw, 12/M10x30 12.9 ISO 7379 Socket Head Shoulder	F81003-70	1	
16	Block, Nozzle Mounting Zinc-plated	090487-1	1	
17	Fitting, 90° Elbow 1/8NPT-1/4 Tube Swivel	P09736	1	
18	Nozzle, Blade Lube Spray	033479	2	
19	Plug, M10x1 DIN 906 BN40 "BOSSARD"	F81015-3	2	
20	Screw, M8x20-8.8 Hex Socket Head Cap Zinc	F81002-30	2	
21	Pivot Weldment, Blade Guide Zinc-plated	089509-1	1	
22	Bolt, M8x40 DIN933 A2-70 Stainless Steel	F81002-28	2	
23	Nut, M8 DIN934 A2-70 Stainless Steel	F81032-7	2	
24	Washer, 8.4 Zinc Flat	F81054-1	4	
25	Bolt, M8x25 DIN933 A2-70 Stainless Steel	F81002-26	2	
	Block, Blade Guide Alignment	090951	1	
26	Block, Blade Guide Alignment Zinc-plated	090805-1	1	
27	Screw, M5x16-8.8 Hex Socket Head Cap Zinc	F81000-25	1	
28	Tool, 62860-3 (PERSCHMAN) Lower Pad Adjustment	090949	1	

**2.2 Blade Guide Assembly, Drive Side**

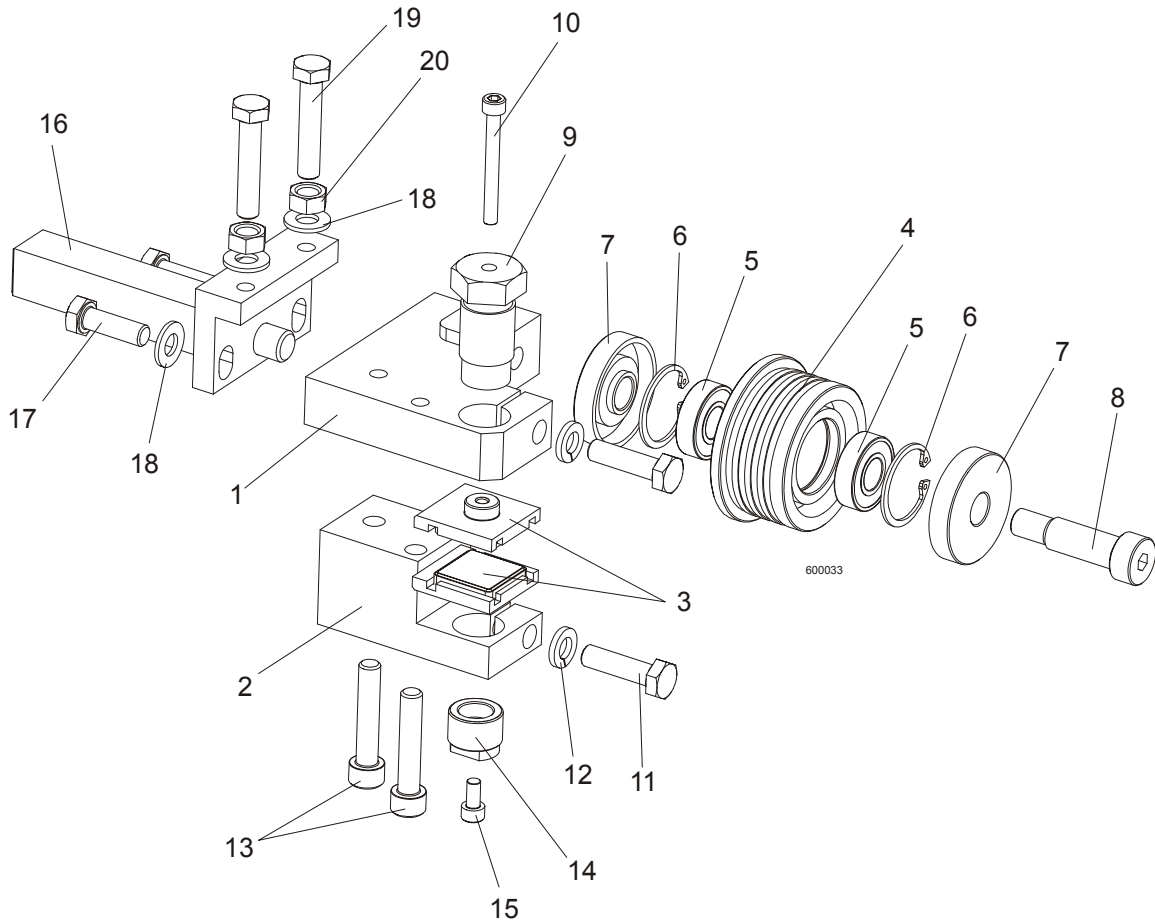

REF	DESCRIPTION (u Indicates Parts Available In Assemblies Only)	PART #	QTY.	
	<b>BLADE GUIDE ASSEMBLY, DRIVE SIDE</b>	090942	1	
<b>1</b>	Block, Blade Guide Mount Zinc-plated	090944-1	1	
<b>2</b>	Block, Lower Ceramic Pad Mount Zinc-plated	090946-1	1	
<b>3</b>	Block assembly, E-Z Glide, Complete	092522	2	
	Roller, Blade Guide Narrow W/Bearing	088261	1	
<b>4</b>	Roller, Blade Guide Narrow	087889	1	
<b>5</b>	Bearing, 6001 2RSR NACHI	087893	2	◆
<b>6</b>	Ring, W28 Inside Retaining	F81090-9	2	
<b>7</b>	Washer, Blade Guide Roller Spacer Zinc-plated	087891	2	
<b>8</b>	Screw, 12/M10x30 12.9 ISO 7379 Socket Head Shoulder	F81003-70	1	
<b>9</b>	Bolt, Upper Pad Adjustment	089515	1	
<b>10</b>	Screw, M5x45 DIN912 A2-70 Hex Socket Head Cap Stainless Steel	F81000-24	1	
<b>11</b>	Bolt, M8x30 DIN933 A2-70 Stainless Steel	F81002-27	2	
<b>12</b>	Washer, 8.2 Split Lock Zinc	F81054-4	2	
<b>13</b>	Screw, M8x40-8.8 Hex Socket Head Cap Zinc	F81002-29	2	

**2****BLADE GUIDE ROLLERS & ARM***Blade Guide Assembly, Drive Side*

---

<b>14</b>	Screw, Lower Pad Adjustment Zinc-plated	090945-1	1	
<b>15</b>	Screw, M5x10 DIN912 A2-70 Hex Socket Head Cap Stainless Steel	F81000-23	1	
<b>16</b>	Pivot Weldment, Blade Guide Zinc-plated	089509-1	1	
<b>17</b>	Bolt, M8x25 DIN933 A2-70 Stainless Steel	F81002-26	2	
<b>18</b>	Washer, 8.4 Zinc Flat	F81054-1	4	
<b>19</b>	Bolt, M8x40 DIN933 A2-70 Stainless Steel	F81002-28	2	
<b>20</b>	Nut, M8 DIN934 A2-70 Stainless Steel	F81032-7	2	



**2.3 Blade Guide Arm Drive Assembly**

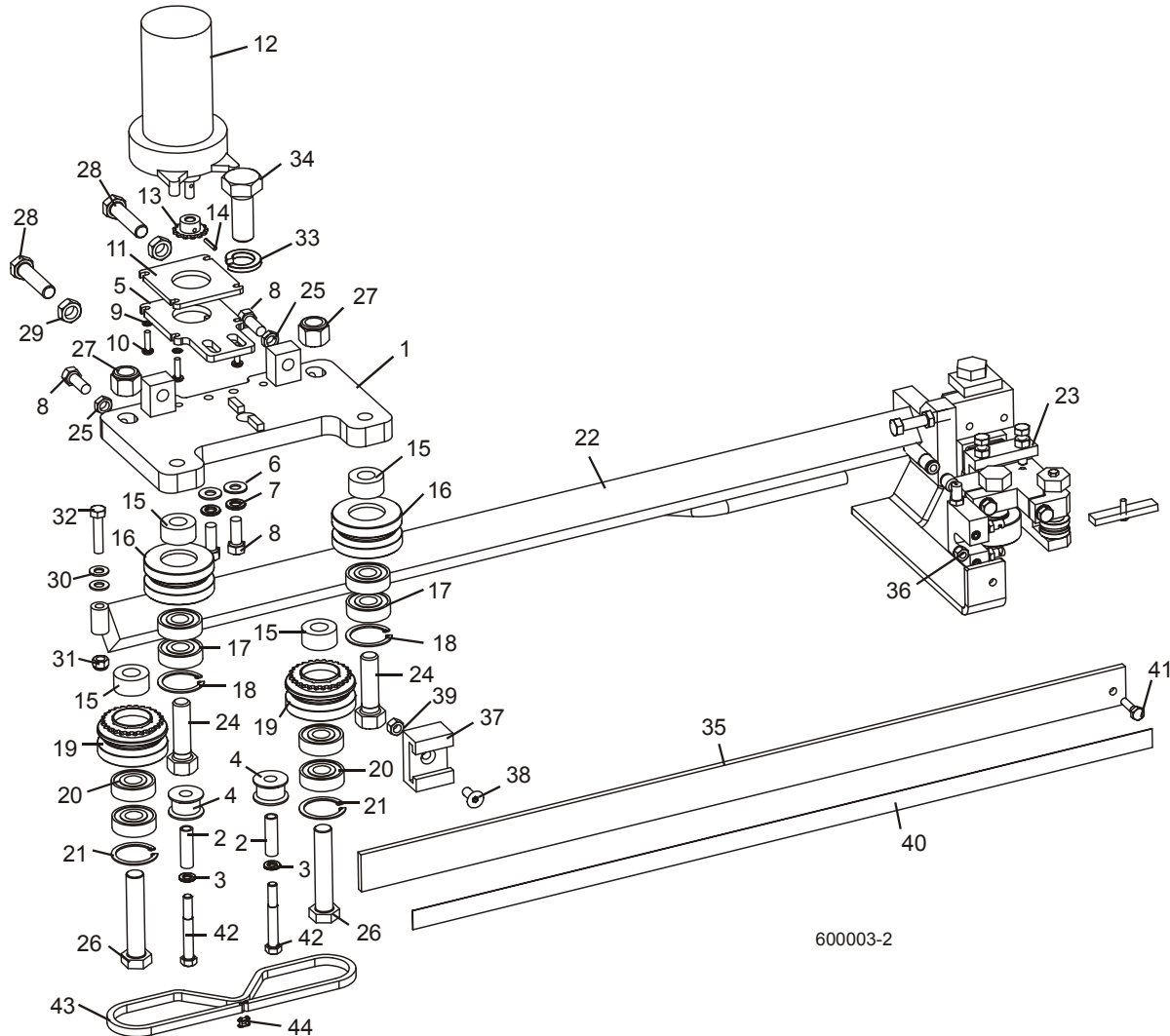

600003-2

REF	DESCRIPTION (u Indicates Parts Available In Assemblies Only)	PART#	QTY.
	<b>BLADE GUIDE ARM ASSEMBLY</b>	090950	1
1	Plate Weldment, Blade Guide Arm Zinc-plated	090800-1	1
2	Bushing, 0.322 x 0.44 x 1 1/2" Spacer	S09996	2
3	Washer, 5/16" Split Lock Zinc	F05011-13	2
4	Roller, Chain Guide	090801	2
5	Plate, Blade Guide Motor Mount Ptd	090803-1	1
6	Washer, 10.5 Zinc Flat	F81055-1	2
7	Washer, 3/8" Zinc Flat	F05011-4	2
8	Bolt, M10 x 25 8.8 Hex Head Full Thread	F81003-31	4
9	Washer, 5.3 Zinc Flat	F81052-1	4
10	Screw, #10-32 x 3/4 CrS1 Phillips Head	F05004-38	4

## 2 BLADE GUIDE ROLLERS & ARM

### Blade Guide Arm Drive Assembly

11	Plate, Spacer Ptd	090802-1	1	
12	Motor, 53:1 Gear ASA Blade Guide Arm	P09698-1	1	
13	Sprocket, 25B13 x .3130	P09970	1	
14	Pin, 3 x 14 Zinc Roll	F81044-4	1	
15	Spacer, Drive Roller Zinc-plated	090804-1	4	
	<b>ROLLER ASSEMBLY, BLADE GUIDE ARM IDLER</b>	042543	2	
16	Housing, 2 1/2" V-Groove	042536	1	
17	Bearing, 6203-2NSL 5/8	P06030-1	2	
18	Ring, 1.575" ID 5002-156 Retaining	F04254-8	1	
	<b>ROLLER ASSEMBLY, BLADE GUIDE ARM DRIVE</b>	042542	2	
19	Housing, 2 1/2" V-Groove W/Sprocket	042541	1	
20	Bearing, 6203-2NSL 5/8	P06030-1	2	
21	Ring, 1.575" ID 5002-156 Retaining	F04254-8	1	
22	Arm Weldment, Blade Guide Zinc-plated	090479-1	1	
23	Blade Guide Parts ( <i>See Section 2.1</i> )			
24	Bolt, 5/8-18 x 2 1/4 Hex Head Grade 5	F05009-80	2	
25	Nut, M10-04-W Zinc Hex Thin	F81033-6	2	
26	Bolt, 5/8-18 x 3 1/4 Hex Head Grade 5	F05009-80	2	
27	Nut, 5/8-18 Hex Nylon Lock	F05010-71	2	
28	Screw, M12 x 1.25 x 60-33H Zinc Hex Set W/Full Dog Point	F81004-52	2	
29	Nut, M12 x 1.25 8.8 Zinc Hex Thin	F81034-5	2	
30	Washer, 8.4 Zinc Flat	F81054-1	1	
31	Nut, M8-8-B Hex Nylon Zinc Lock	F81032-2	1	
32	Bolt, M8 x 40-8.8 Hex Head Full Thread Zinc	F81002-15	1	
33	Washer, DIN 6319-21C Spherical	F81059-6	1	
34	Bolt, M20 x 1.5 x 50-8.8-B Hex Head Full Thread Zinc	F81007-2	1	
35	Guard, Blade	088306	1	
36	Nut, M6-8-B Hex Nylon Zinc LOck	F81031-2	1	
37	Guide, Blade Guard	088305	1	
38	Screw, M8 x 25 Cross Recessed Countersunk Head Zinc	F81002-51	1	
39	Nut, M8-8-B Hex Nylon Zinc Lock	F81032-2	1	
40	Decal, Warning	015849	1	
41	Bolt, M6 x 20-8.8 Hex Head Full Thread Zinc	F81001-2	2	
42	Screw, 12/M10 x 20 12.9 ISO7379(BOSSARD) Socket Head Shoulder	F81003-68	2	
43	Chain, #25 x 92 PITCHES B/G	042443	1	
44	Link, Master	P09983	2	

## SECTION 3 BLADE WHEELS & TENSIONER

### 3.1 Blade Drive Assembly

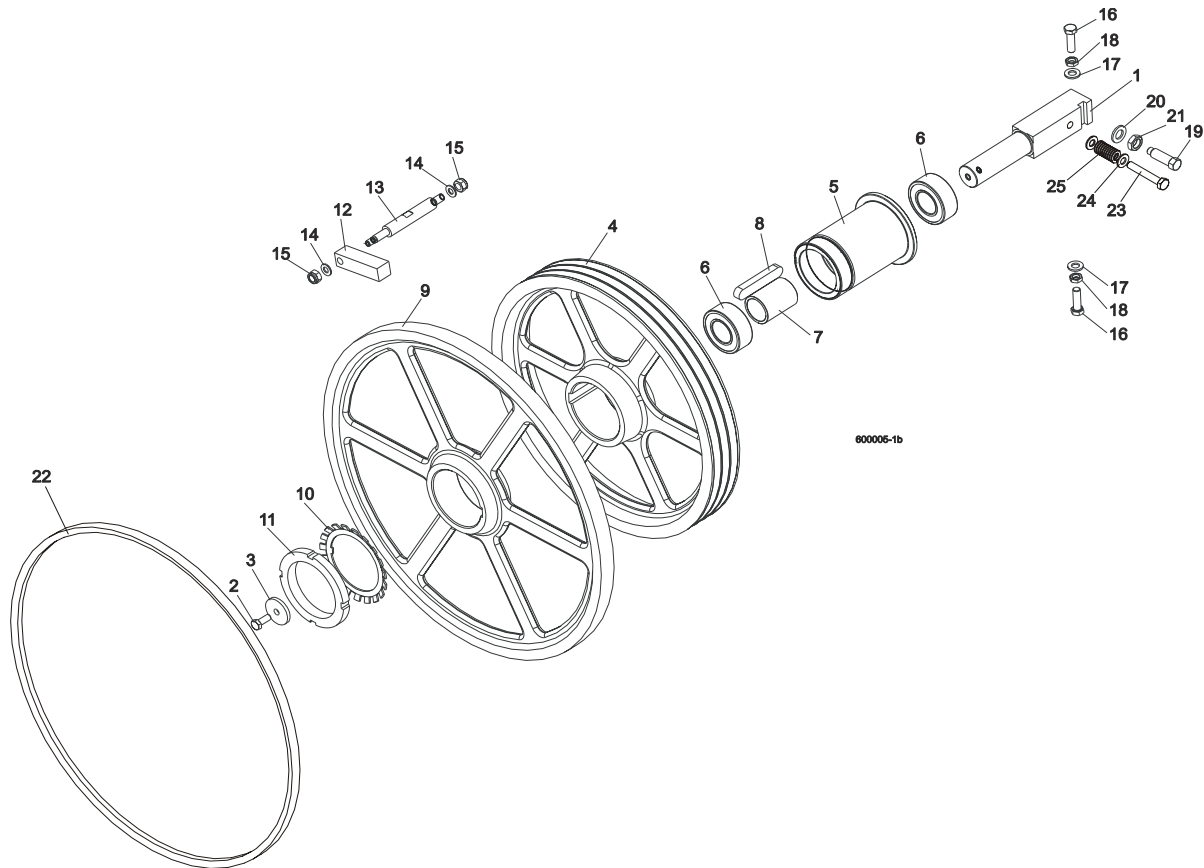

REF	DESCRIPTION (◆ Indicates Parts Available In Assemblies Only)	PART #	QTY.
1	SHAFT, BLADE DRIVE WHEEL	088475	1
2	BOLT, M10x25 8.8 HEX HEAD FULL THREAD	F81003-31	1
3	WASHER, BLADE DRIVE WHEEL	088956-1	1
	PULLEY ASSEMBLY, BLADE DRIVE	088561	1
4	Pulley, 3-Groove 484 mm Diameter	089457-1	1
5	Bushing, Blade Drive Wheel	088476	1
6	Bearing, 3208.2rsr.tvh (FAG) Rolling	088449	2
7	Spacer, Drive Bearing	088478	1
8	Key, A20x12x100 Parallel	088477	1
9	WHEEL, BLADE DRIVE	090811	1
10	WASHER, MB21 (FAG) LOCK	088451	1
11	NUT, KM21(M105X2) (FAG) LOCK	088450	1
12	BAR, WHEEL SCRAPER	088781	1
13	SHAFT, WHEEL SCRAPER	088780-1	1

### **3** Blade Wheels & Tensioner

*Blade Drive Assembly*

---

14	WASHER, 10.5 ZINC FLAT	F81055-1	2	
15	NUT, M12-8 HEX NYLON ZINC LOCK	F81034-2	2	
16	BOLT, M12X1.25X40 HEX HEAD	F81004-42	3	
17	WASHER, 13 FLAT ZINC	F81056-1	3	
18	NUT, M12X1.25 8.8 THIN ZINC	F81034-5	3	
19	SCREW, M16X1.5X50-33H HEX HEAD FULL DOG POINT SET ZINC	F81006-14	1	
20	WASHER, 17 ZINC FLAT	F81058-1	1	
21	NUT, M16x1.5-08-B ZINC THIN	F81036-6	1	
22	BELT, BLADE WHEEL B72.5	017922	1	
23	BOLT M10X65	F81003-67	1	
24	WASHER, 10.5 ZINC FLAT	F81055-1	2	
25	SPRING19X38	034430	1	

### 3.2 Idle Blade Wheel Assembly

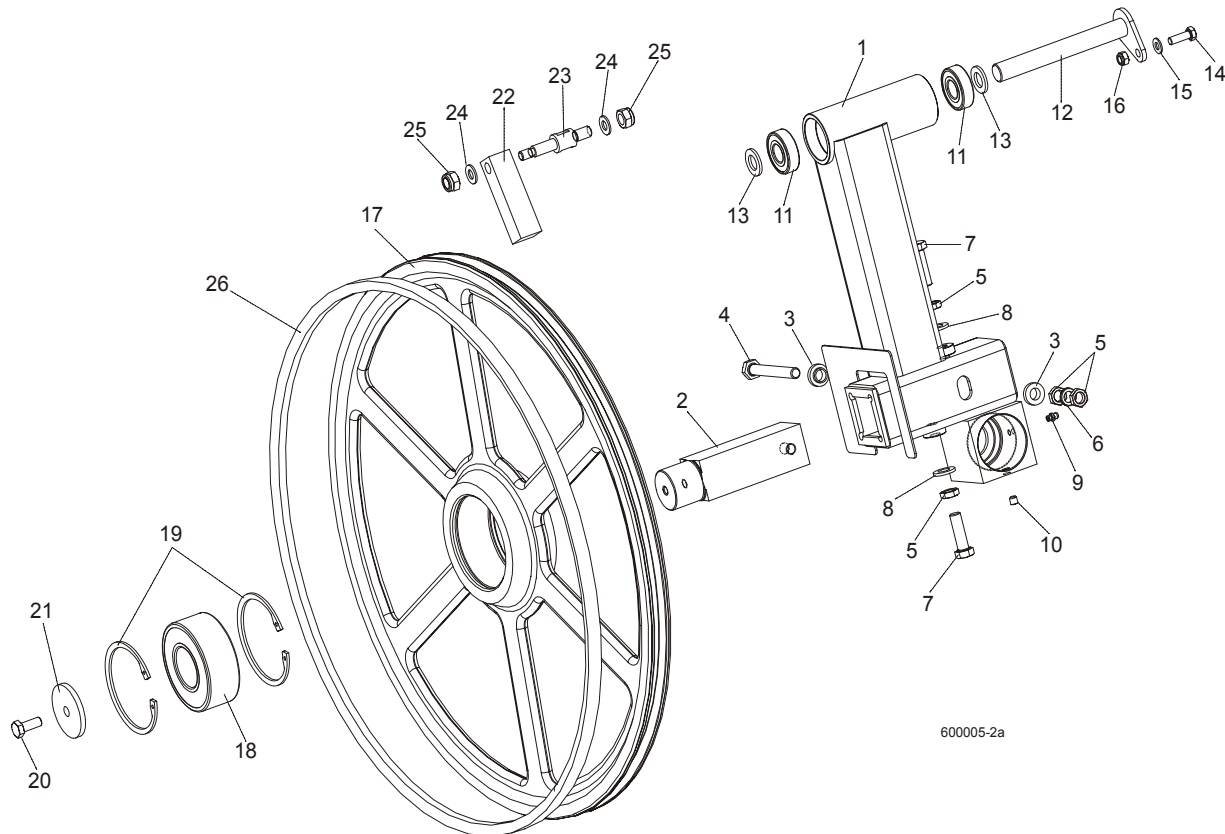

600005-2a

REF	DESCRIPTION (◆ Indicates Parts Available In Assemblies Only)	PART #	QTY.
	<b>TUBE WELDMENT, LT60 IDLE SIDE BLADE WHEEL COMPLETE</b>	088762	1
1	Tube Weldment, LT60 Idle Blade Wheel	088434-1	1
2	Shaft, Idle Blade Wheel	088474	1
3	Washer, Zinc Special	086769-1	2
4	Bolt, M12x1.25x100-8.8 Hex Head Zinc	F81004-41	1
5	Nut, M12x1.25 8.8 Hex ZincThin	F81034-5	4
6	Washer, Z12.2 Split Zinc Lock	F81056-2	1
7	Bolt, M12x1.25x40 Hex Head	F81004-42	2
8	Washer, 13 Zinc Flat	F81056-1	2
9	Fitting, M6 Straight Grease	086280	1
10	Screw, M8x8-33H Hex Socket Set Flat Point Zinc	F81014-1	1
11	Bearing, 6204 2RS-CX Rolling	088447	2
12	<b>PIN WELDMENT, PIVOT</b>	088759-1	1
13	<b>WASHER, 17 ZINC FLAT</b>	F81058-1	2
14	<b>BOLT, M8X25-8.8-B HEX HEAD FULL THREAD ZINC</b>	F81002-5	1
15	<b>WASHER, 8.4 ZINC FLAT</b>	F81054-1	1
16	<b>NUT, M8-8-B HEX NYLON ZINC LOCK</b>	F81032-2	1

### **3** Blade Wheels & Tensioner

*Idle Blade Wheel Assembly*

---

	<b>WHEEL ASSEMBLY, IDLE SIDE</b>		1	
17	Wheel, Blade Idle Side	090810	1	
18	Bearing, 3309B.2RSR.TVH-P66 FAG	086428	1	
19	Ring, W100 Spring Retaining	F81090-10	2	
20	<b>BOLT, M10X25 8.8 HEX HEAD FULL THREAD</b>	F81003-31	1	
21	<b>WASHER, IDLE BLADE WHEEL RETAINING</b>	088957-1	1	
22	<b>SCRAPER, IDLE BLADE WHEEL</b>	088781	1	
23	<b>SHAFT, SHORT ZINC WHEEL SCRAPER</b>	088779-1	1	
24	<b>WASHER, 10.5 ZINC FLAT</b>	F81055-1	2	
25	<b>NUT, M12-8 HEX NYLON ZINC LOCK</b>	F81034-2	2	
26	<b>BELT, BLADE WHEEL B72.5</b>	017922	1	

### 3.3 Blade Tensioner Assembly

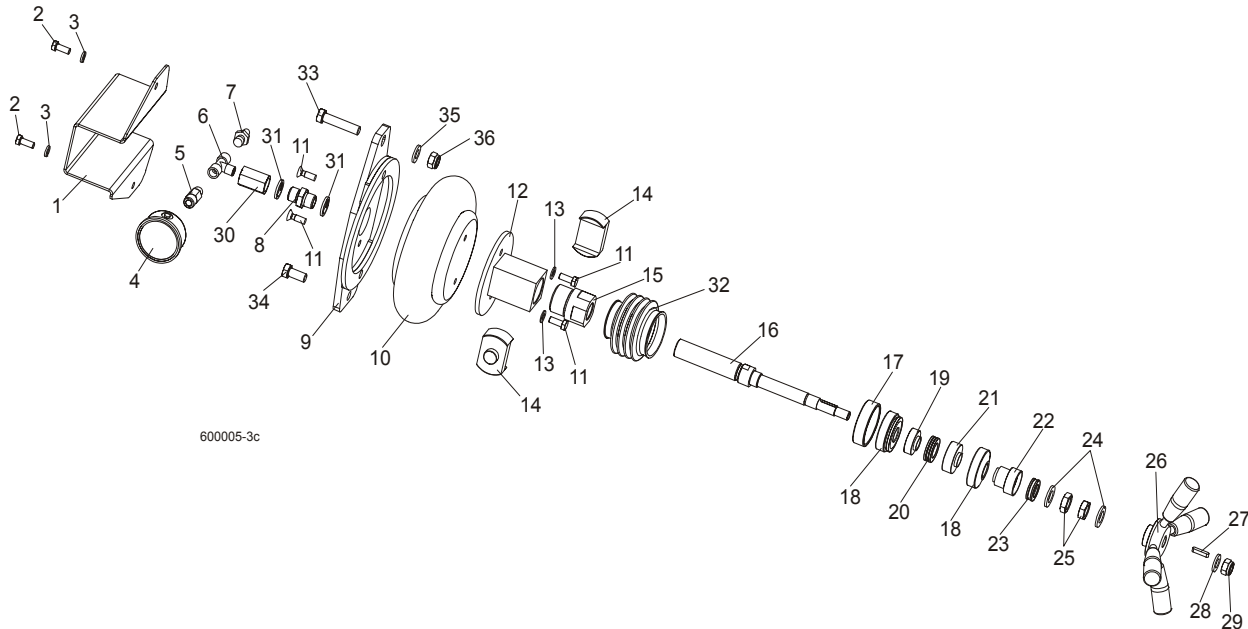

REF	DESCRIPTION (◆ Indicates Parts Available In Assemblies Only)	PART #	QTY.
	<b>BLADE TENSIONER, COMPLETE</b>	088790	1
1	Guard, Air Pressure Gauge	088924	1
2	Bolt, M8x20-8.8-B Hex Head Full Thread Zinc	F81002-4	2
3	Washer 8.2 Zinc Split	F81054-4	2
4	Gauge, M63T-2,5/20G G 1/8 0-0,6 MPa/PSI Air Pressure	088568	1
5	Nipple, 1/8" Thread x 1/4" Thread	088571	1
6	Fitting, PO 2301 002 2 Tee Connector	088573	1
7	Fitting, 1/4" Thread 390 004 004 0 (REXROTH) Air Tank Valve	088575	1
8	Nipple, G1/4z/G1/4z 893-104-430-4	090807	1
9	Bracket, Air Bag Mount	088798-1	1
10	Bag, POJ 192 308 100 0 Air	088576	1
11	Screw, M8x25 Cross Recessed Countersunk Head Zinc	F81002-4	4
12	Tube Weldment, Tensioner Nut	088795-1	1
13	Washer, 8.4 Zinc Flat	F81054-1	2
14	Plate, Tube Guide	089433	1
15	Nut, Blade Tensioner	091754	1
16	Bolt, Blade Tensioner Special	091753-1	1
17	Seat, Spherical Bearing Threaded	088803-1	1
18	Bearing, GE20 AW (ELGES) Spherical Plain Thrust	089430	2
19	Bushing, Bearing Spacer	088791	1
20	Bearing, 51104 Thrust Ball	088989	1
21	Seat, 51104 Thrust Bearing	089439	1

## 3

**Blade Wheels & Tensioner***Blade Tensioner Assembly*

22	Seat, 51103 Thrust Bearing	089440-1	1	
23	Bearing, 51103 FLT Thrust Ball	086675	1	
24	Washer, 17 Zinc Flat	F81058-1	2	
25	Nut, M16x1,5-08-B Zinc Thin	F81036-6	2	
26	Handle, Blade Tensioner Complete	089431	1	
27	Key, A5x5x25 Parallel	089432	1	
28	Washer, 13 Zinc Flat	F81056-1	1	
29	Nut, M12-8 Hex Nylon Zinc Lock	F81034-2	1	
30	Nipple, G1/4w/G1/4w 893-302-000-4	090808	1	
31	Seal, G1/4 866-014-000-0	090809	2	
32	<b>Guard, Rubber Blade Tensioner Bolt</b>	<b>091317</b>	1	
33	<b>BOLT, M12x55-8.8 HEX HEAD ZINC</b>	F81004-12	1	
34	<b>BOLT, M12x25-8.8 HEX HEAD FULL THREAD ZINC</b>	F81004-31	1	
35	<b>WASHER,13 ZINC FLAT</b>	F81056-1	1	
36	<b>NUT, M12-8 HEX NYLON ZINC LOCK</b>	F81034-2	1	



### 3.4 Sawdust Flow Guide

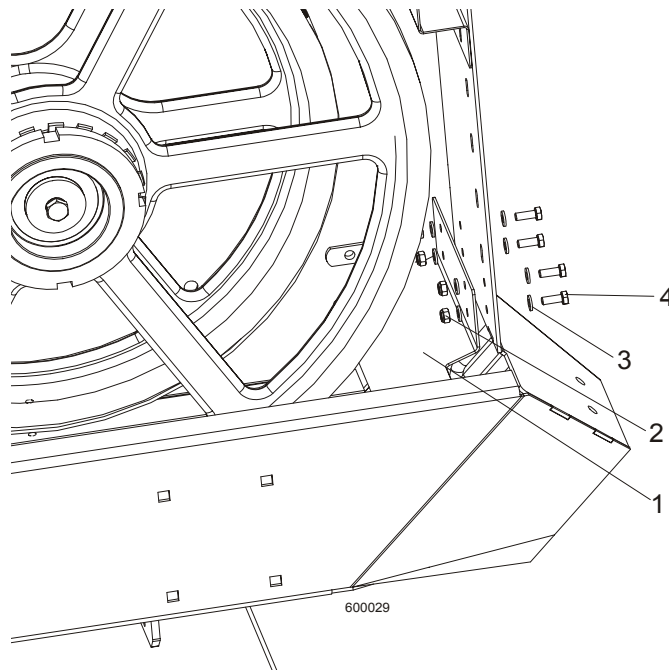

REF	DESCRIPTION (◆ Indicates Parts Available In Assemblies Only)	PART #	QTY.	
1	Guide, Sawdust Flow Painted	090506	1	
2	Nut, M6-8-B Hex Nylon Zinc Lock	F81031-2	4	
3	Washer 6.4 Zinc Flat	F81053-1	8	
4	Bolt, M6x16-8.8, Hex Head Full Thred, Zinc	F81001-32	4	



**SECTION 4 SAW HEAD**

**4.1 Middle Throat Screw**

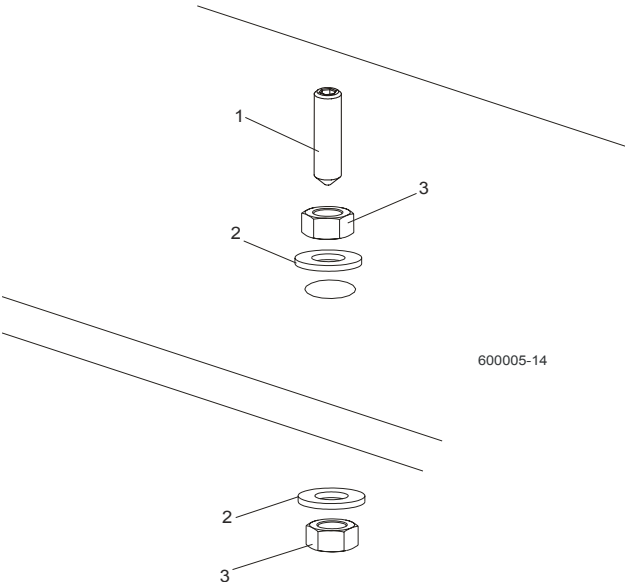

REF	DESCRIPTION (◆ Indicates Parts Available In Assemblies Only)	PART #	QTY.	
1	SCREW, M10X40-45H HEX SOCKET SET CONE POINT ZINC	F81003-61	1	
2	WASHER, 10.5 ZINC FLAT	F81055-1	2	
3	NUT, M10-8-B ZINC HEX	F81033-3	2	

# 4 Saw Head

## Drive Belt Tensioner

### 4.2 Drive Belt Tensioner

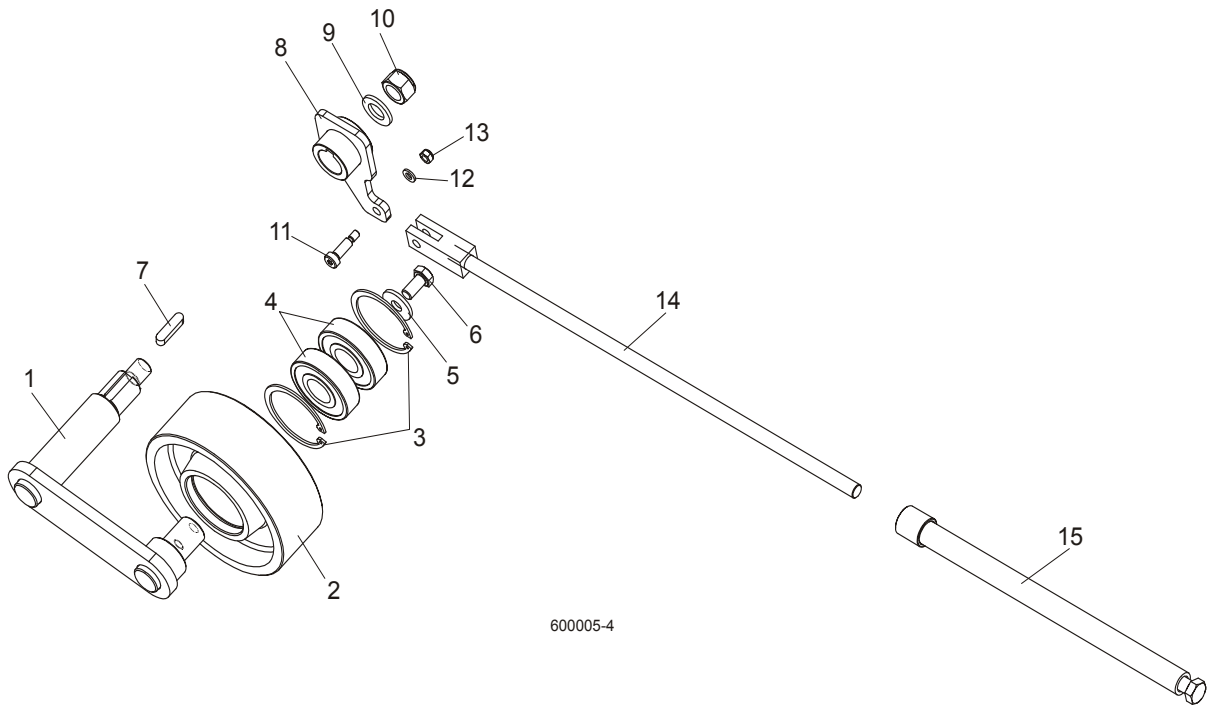

REF	DESCRIPTION (◆ Indicates Parts Available In Assemblies Only)	PART #	QTY.
	<b>TENSIONER ASSEMBLY, DRIVE BELT</b>	088786	1
1	Pivot Weldment, Drive Belt Tensioner	088810-1	1
2	Wheel, Belt Tension	088814	1
3	Ring, 62 mm Inside Spring Retaining	F81090-1	2
4	Bearing, 6305 2RS NSK	P08066	2
5	Washer, 11 Zinc Flat Special	088787-1	1
6	Bolt, M10x20-5.8 Hex Head Full Thread Zinc	F81003-1	1
7	Key, A8X7X32 Parallel	088564	1
8	Arm Weldment, Drive Belt Tensioner	088807-1	1
9	Washer, 17 Zinc Flat	F81058-1	1
10	Nut, M16-5.8 Zinc Hex	F81036-1	1
11	Bolt, 8/M6X20 12.9 ISO 7379 BOSSARD	F81001-25	1
12	Washer 6.4 Zinc Flat	F81053-1	1
13	Nut, M6-8-B Hex Nylon Zinc Lock	F81031-2	1
14	Rod Weldment, Threaded	088789-1	1
15	Tube Weldment, Threaded	088782-1	1

4.3 Board Return Assembly

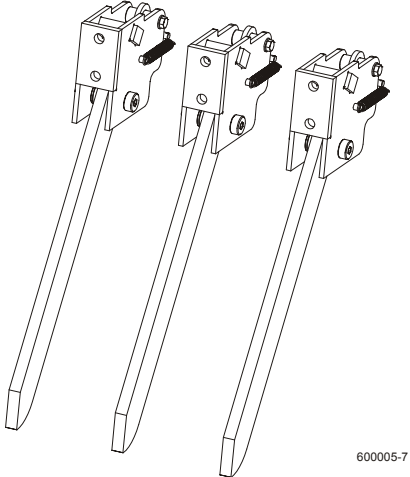

600005-7

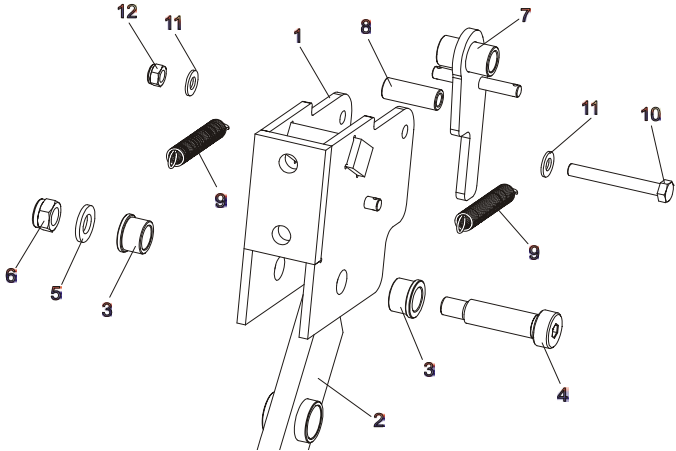

REF	DESCRIPTION (◆ Indicates Parts Available In Assemblies Only)	PART #	QTY.
	<b>BOARD RETURN ASSEMBLY</b>	090120	3
1	<b>MOUNT WELDMENT, BOARD RETURN ARM</b>	090109-1	3
2	<b>ARM, BOARD RETURN</b>	090112-1	3
3	<b>Bushing, Bronze</b>	086676	6
4	<b>BOLT, 16/M12X50-12.9 ISO7379-BOSSARD SOCKET HEAD</b>	F81004-25	3
5	<b>WASHER, 13 ZINC FLAT</b>	F81056-1	3
6	<b>NUT, M12-8 HEX NYLON ZINC LOCK</b>	F81034-2	6
7	<b>LATCH WELDMENT, BOARD RETURN ARM</b>	090118-1	3
8	<b>SPACER, ZINC</b>	090115-1	3
9	<b>SPRING, 1/2 X 2 1/4 X .06 EXTENSION</b>	014817	6
10	<b>BOLT, M8 X 65-5.8 HEX HEAD ZINC</b>	F81002-3	3
11	<b>WASHER, 8.4 ZINC FLAT</b>	F81054-1	6
12	<b>NUT, M8-8-B HEX NYLON ZINC LOCK</b>	F81032-2	3

# 4 Saw Head

## Water Lube Assembly

### 4.4 Water Lube Assembly

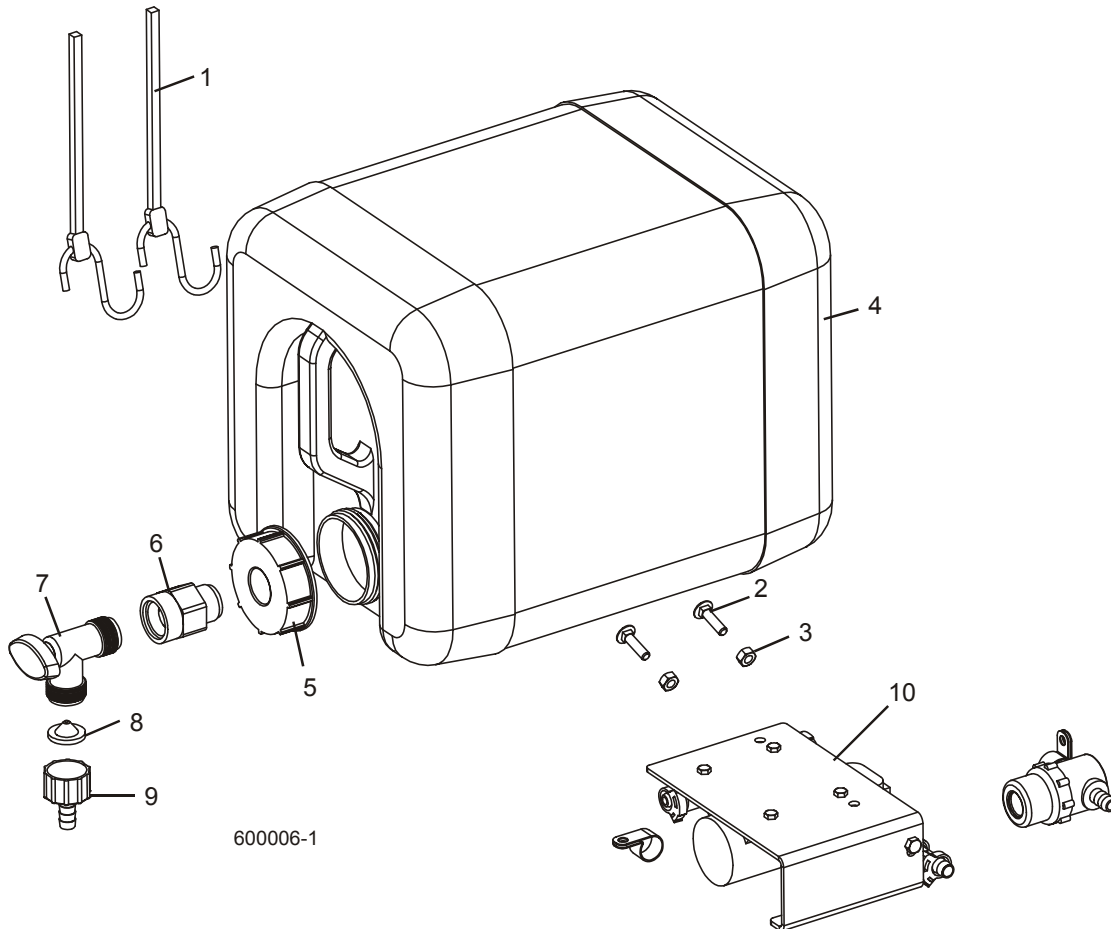

REF	DESCRIPTION (◆ Indicates Parts Available In Assemblies Only)	PART #	QTY.	
1	STRAP, 20" RUBBER	P11668	2	
2	BOLT, 1/4-20 X 1" CARRIAGE HEAD	F05005-34	2	
3	NUT, 1/4-20 HEX LOCK	F05010-21	2	
	<b>BOTTLE ASSY, WATER LUBE</b>	014642	1	
4	Bottle, 5-Gallon Water Lube	014637	1	◆
5	Cap, Water Lube Bottle Buttress Thread	014773	1	
6	FITTING, 3/4FPT X 3/4MPT	014636	1	
7	FITTING, WATER LUBE SHUTOFF VALVE	014100	1	
8	FILTER, WATER LUBE	016086	1	
9	FITTING, 5/8" NPT TO 3/8" HOSE BARB	014113	1	
10	LUBEMIZER PARTS/HOSES (SEE LUBEMIZER OPTION MANUAL)			

## 4.5 Saw Head Decals

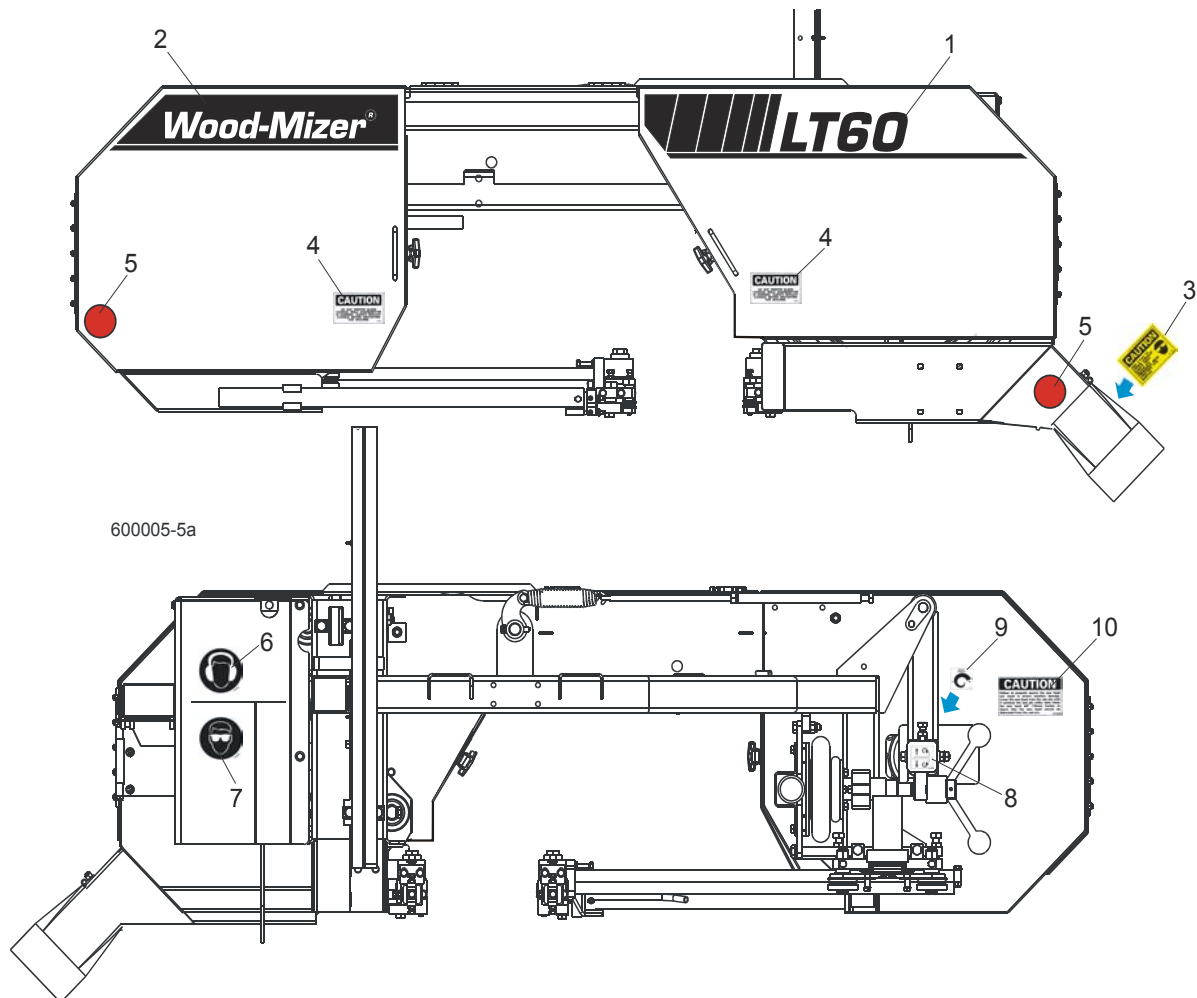

REF	DESCRIPTION (◆ Indicates Parts Available In Assemblies Only)	PART #	QTY.
1	DECAL, LT60 LOGO	088908	1
	DECAL, LT70 LOGO	089550	1
	DECAL, LT80 LOGO	087932	1
2	DECAL, WOOD-MIZER LOGO	087935	1
3	DECAL, SAWDUST CHUTE CAUTION	P11754	1
4	DECAL, BLADE COVERS DANGER	S20039	2
5	REFLECTOR, 2" RED	P07452	2
6	DECAL, EYE WARNING	S12004G	1
7	DECAL, EAR WARNING	S12005G	1
8	DECAL, BLADE ALIGNMENT	P11789	1
9	DECAL, BLADE TENSION SCREW	P11790	1
10	DECAL, SAW HEAD REST CAUTION	S12581	1

# 4 Saw Head Blade Housing Covers

## 4.6 Blade Housing Covers

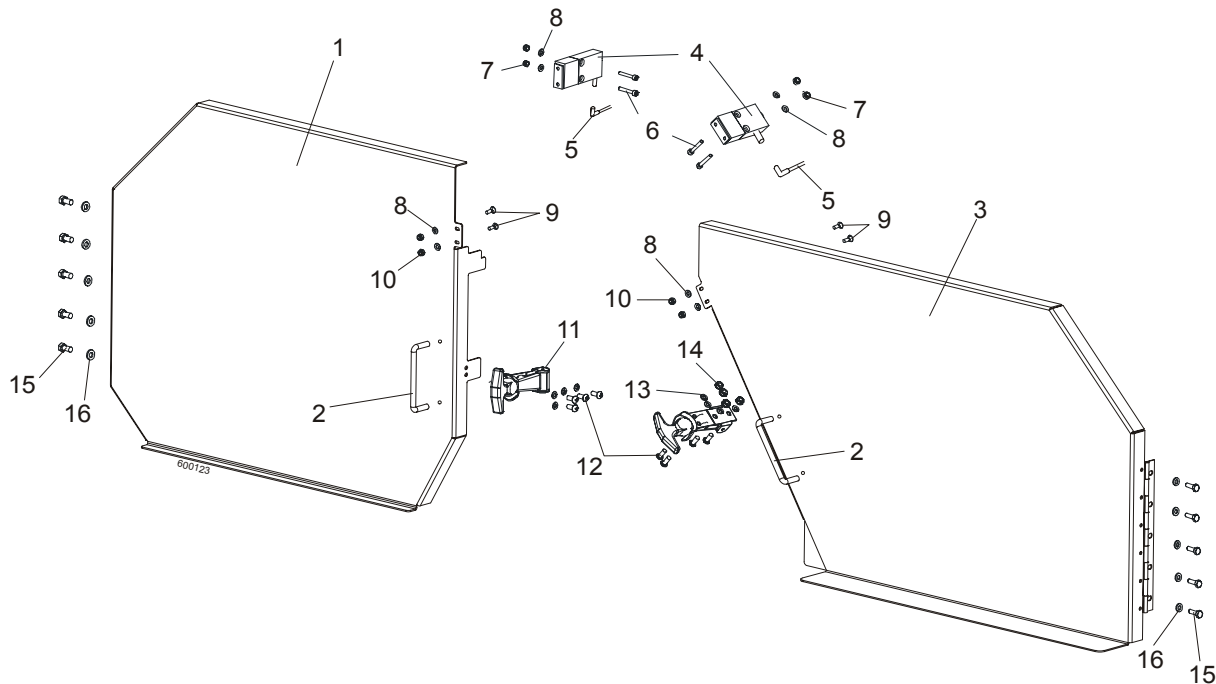

REF	DESCRIPTION (◆ Indicates Parts Available In Assemblies Only)	PART #	QTY.
	<b>COVER ASSEMBLY, IDLE SIDE BLADE HOUSING</b>	088920	1
1	Cover Assembly, Idle Side Blade Housing, Ptd	088915-1	1
2	Handle, Blade Housing Cover	P08065	1
	<b>COVER ASSEMBLY, DRIVE SIDE BLADE HOUSING</b>	088921	1
3	Cover Assembly, Drive Side Blade Housing, Ptd	088917-1	1
2	Handle, Blade Housing Cover	P08065	1
4	<b>SWITCH, GKMB23W2 HONYWELL SAFETY KEY</b>	086681	2
5	<b>CABLE, 5M SAFETY KEY SWITCH</b>	087652	2
6	<b>SCREW, M4X20 8,8 SOCKET HEAD CAP ZINC</b>	F81011-31	4
7	<b>NUT, M4-B HEX NYLON ZIN</b>	F81029-1	4
8	<b>WASHER 4,3 ZINC, FLAT</b>	F81051-2	8
9	<b>SCREW, M4X12 5,8-B SLOTTED COUTERSUNK HEAD ZINC</b>	F81011-41	4
10	<b>NUT M4-B HEX NYLON ZINC LOCK</b>	F81029-1	4
11	<b>LATCH, FLEXIBLE DRAW</b>	014829	2
12	<b>BOLT, M5X12-5.8</b>	F81000-5	8
13	<b>WASHER 5,3 ZINC FLAT</b>	F81052-1	8
14	<b>NUT M5-8 DIN 985 ZINC</b>	F81030-2	8
15	<b>BOLT, M6X16 8.8 HEX HEAD FULL THREAD ZINC</b>	F81001-15	10
16	<b>WASHER 6.4 ZINC FLAT</b>	F81053-1	10



## 4.7 Sawdust Chute

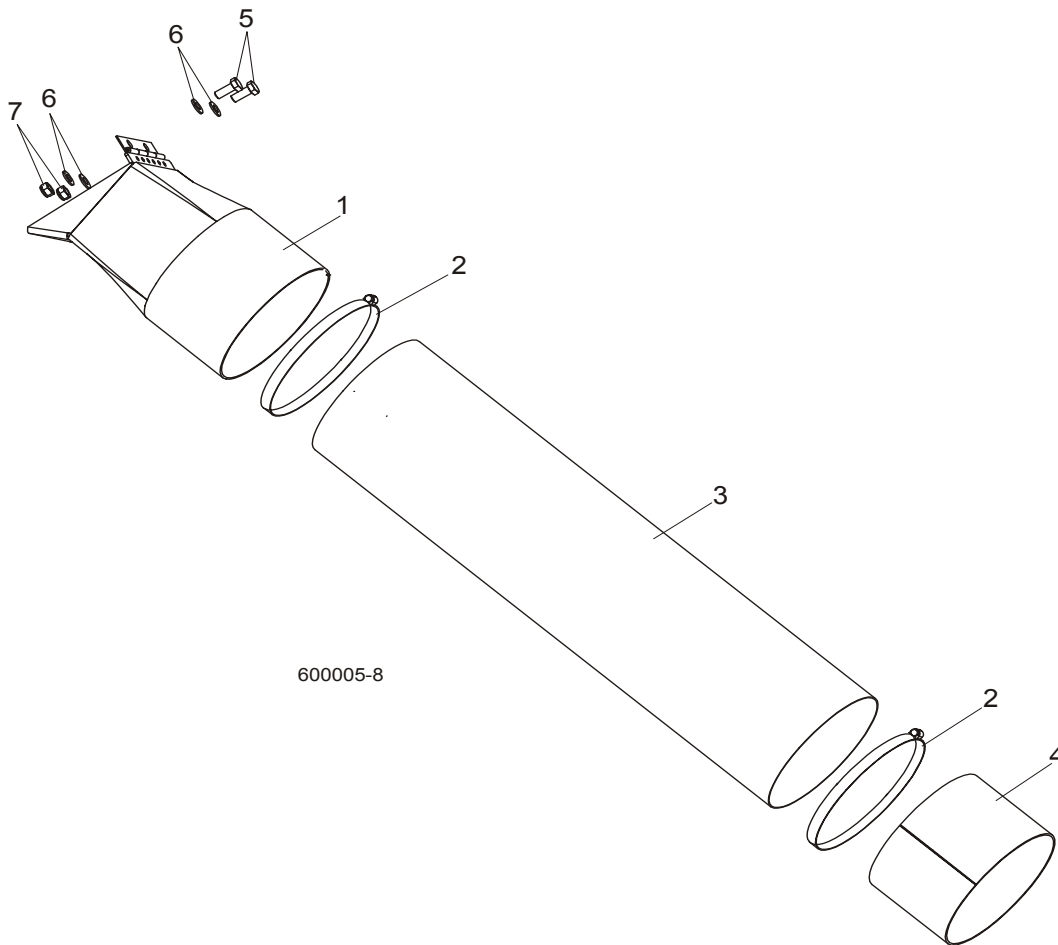

REF	DESCRIPTION (◆ Indicates Parts Available In Assemblies Only)	PART #	QTY.	
1	CHUTE WELDMENT, SAWDUST	089352-1	1	
2	CLAMP, 152 MM	089358	2	
3	TUBE, SAWDUST CHUTE	090153	1	
4	TUBE, CHUTE END	090126-1	1	
5	BOLT, M8X20-8.8-B HEX HEAD FULL THREAD ZINC	F81002-4	2	
6	WASHER 8.4 ZINC FLAT	F81054-1	4	
7	NUT, M8-8-B HEX NYLON ZINC LOCK	F81032-2	2	



	<b>CONTROL BOX ASSEMBLY, E25</b>	086571	1	
	<b>CONTROL BOX ASSEMBLY, D40</b>	086572	1	
1	Box Weldment, Sawmill Control	016135	1	◆
2	Plug, AS075 Oiltite	E20570	1	
3	Solenoid Parts ( <a href="#">See Section 5.4</a> )			
4	Screw, #10-24 x 1/2" Pan Head	F05015-17	16	
5	Panel Assembly, Power Feed Control	024412	1	
	Control Module, Power Feed SMT	024396-1	1	
6	Gasket, Rear Access Panel	015278	1	
7	Front Control Panel & Wiring Harnesses ( <a href="#">Section 5.5</a> )			
8	Drum Switches ( <a href="#">Section 5.2</a> )			
9	Circuit Breakers ( <a href="#">Section 5.3</a> )			
10	Screw, #10-24 x 3/8" Phillips Pan Head	F05004-3	2	
11	Screw, #10-24 x 3/8" Phillips Pan Head Machine with Neo Washer	F05004-148	4	
12	Nut, #10-24 Self Locking	F05010-14	6	
13	Bolt, 3/8-16 x 3/4" Hex Head	F05007-27	2	
14	Washer, 10.5 Flat	F81055-1	2	
15	Nut, 3/8" Lock Nut	F05010-19	2	
16	Cover, Control Box Hinged	015304	1	
17	Nut, 1/4-20 Self Locking	F05010-9	2	
18	Bolt, 1/4-20 x 1 1/4" Hex Head Tap	F05005-3	1	
19	Solenoid, Accessory	P10449	1	
	Diode Assembly, Solenoid Coil Chassis BND	087496	1	
20	Gasket, Front Access Panel	015266	1	
21	Panel, Control Box Front Access	086704-1	1	
22	<b>MOUNT WELDMENT, STANDARD CONTROL BOX</b>	086732-1	1	
23	<b>NUT, 5/16-18 SELF-LOCKING HEX</b>	F05010-20	4	
24	<b>BOLT, M10 X 25-8.8 SOCKET HEAD</b>	F81003-32	4	
25	<b>WASHER, 10.2 SPLIT LOCK</b>	F81055-2	4	
26	<b>WASHER, 3/8" EXTERIOR STAR LOCK</b>	F05011-36	4	
27	<b>DECAL, FRONT OUTRIGGER WARNING</b>	015400	1	
28	<b>DECAL, EAR/EYE PROTECTION WARNING</b>	S11753	1	
29	<b>DECAL, DISCONNECT BATTERY DANGER</b>	S12002	1	
30	<b>DECAL, CIRCUIT BREAKER ID ('98 SUPER)</b>	024362	1	
31	<b>SWITCH, RED EMERGENCY STOP XALJ174F</b>	E22703-2	1	

## 5.2 Drum Switches

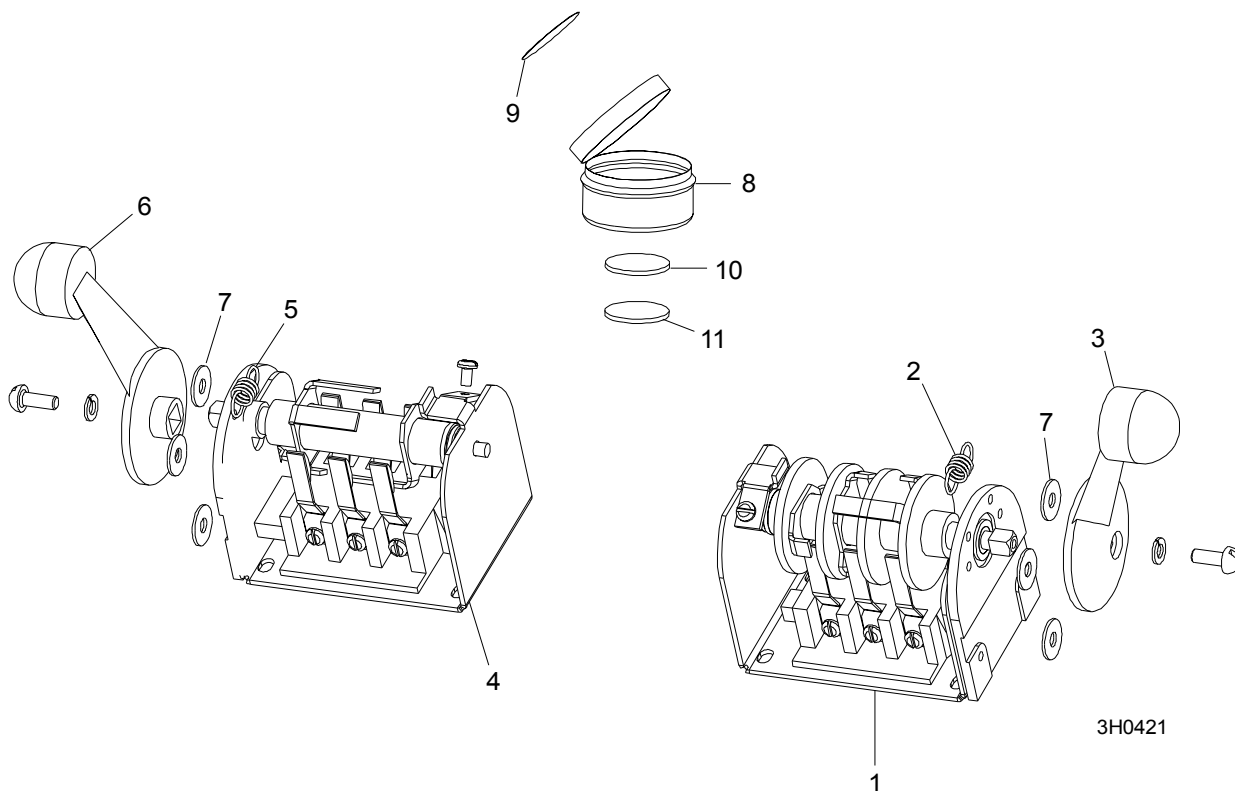

REF	DESCRIPTION (◆ Indicates Parts Available In Assemblies Only)	PART #	QTY.	
	<b>SWITCH ASSEMBLY, UP/DOWN DRUM</b>	E20440	1	
1	Switch, S12 Bulk Drum	E20440-B	1	◆
2	Spring, Drum Switch	P12570	1	
3	Handle, Drum Switch Replacement	P12500	1	
	<b>SWITCH ASSEMBLY, POWER FEED DRUM</b>	E20438	1	
4	Switch, S10 Bulk Drum	E20438-B	1	◆
5	Spring, Drum Switch	P12570	1	
6	Handle, Drum Switch Replacement	P12500	1	
7	<b>WASHER, #8 SAE FLAT</b>	F05011-41	6	
	<b>CUP ASSEMBLY, DRUM SWITCH GREASE</b>	A20463	1	
8	Cup, Plastic Container	P20464	1	◆
9	Decal, Grease Cup Label	P20467	1	
10	Pad, Velcro Loop	P20466	1	◆
11	Pad, Velcro Hook	P20465	1	◆
	Grease, High Temp Drum Switch	P20468	.011ml	◆

### Front Panel Assembly & Harnesses

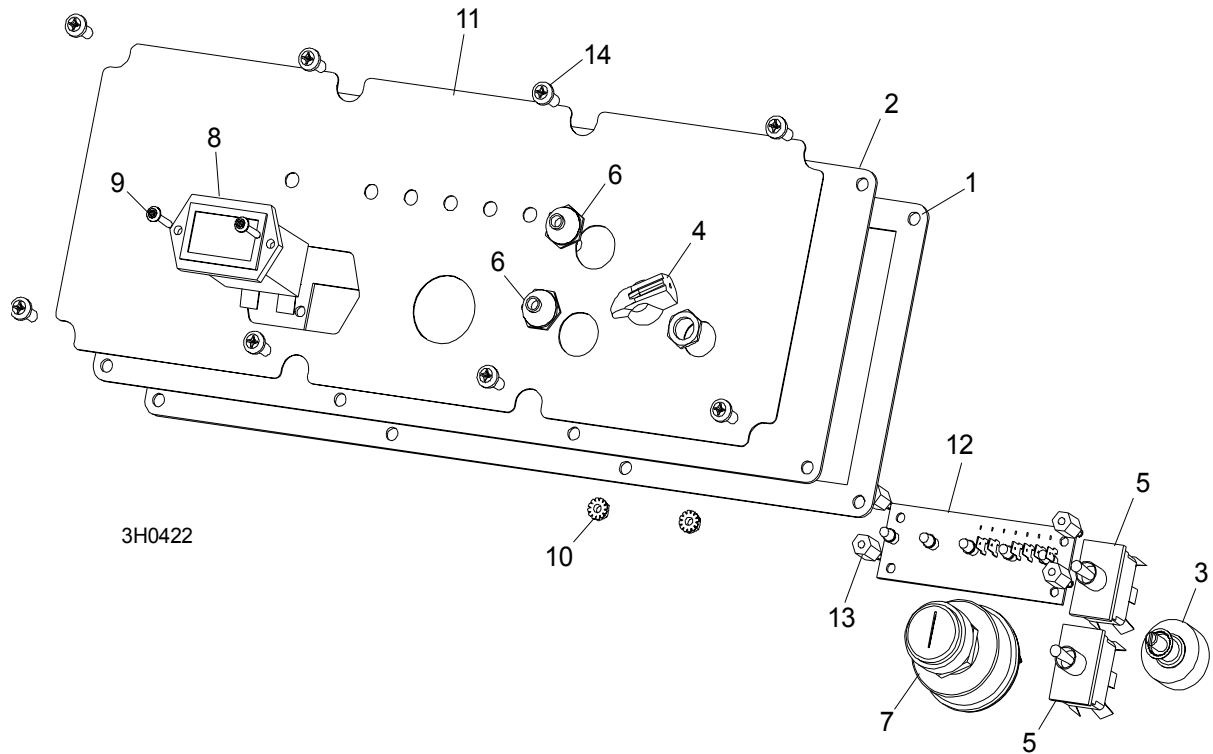

REF	DESCRIPTION (◆ Indicates Parts Available In Assemblies Only)	PART #	QTY.
	<b>PANEL ASSEMBLY, CONTROL FRONT (E25)</b>	086760	1
	<b>PANEL ASSEMBLY, CONTROL FRONT (D40)</b>	087401	1
1	Gasket, Front Panel	088387	1
2	Panel Weldment, Control	015302	1
3	Switch Assembly, Feed Rate	E20519	1
4	Knob, Feed Rate With Set Screw	P06257	1
5	Switch, Toggle	024200	2
6	Boot, Toggle Switch Rubber	P02575	2
7	Switch, Key	P04350	1
8	Meter, Hour	015401	1
9	Screw, 6-42 x 3/4" Socket Button Head Cap Stainless Steel	F05004-93	2
10	Nut, 6-23 Self Locking	F05010-59	2
11	Decal, Control Panel (E25)	015271	1
	Decal, Control Panel (D40)	015269	1
12	Board, LED Circuit (E25)	015416	1
	Board, LED Circuit (D40)	015409	1
13	Spacer, 1/2" #6 Threaded	023147	4
	<b>HARNESS ASSEMBLY, UPPER WIRING (E25)</b>	024843	1
	<b>HARNESS ASSEMBLY, UPPER WIRING (D40)</b>	087107	1
	<b>HARNESS ASSEMBLY, LOWER WIRING (D40)</b>	087106	1
	<b>HARNESS ASSEMBLY, LOWER WIRING (E25)</b>	015421	1

# 5

## Control & Battery Boxes

### *Drum Switches*

---

14	Screw, #10-24 x 1/2" Pan Head	F05015-17	8	
----	-------------------------------	-----------	---	--

### 5.3 Circuit Breakers

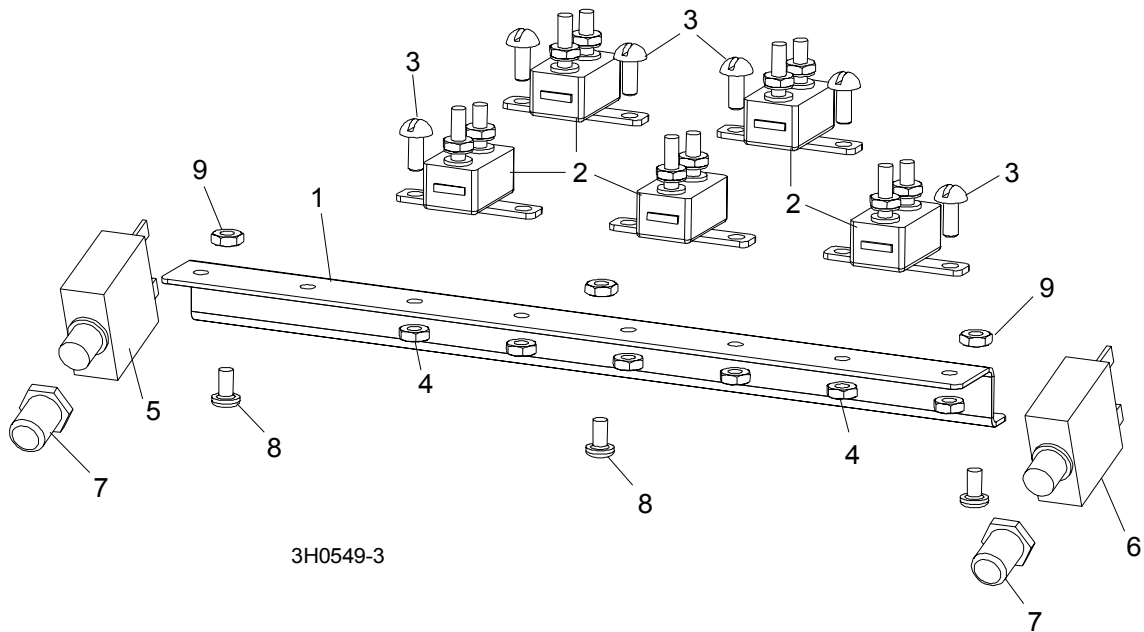

REF	DESCRIPTION (◆ Indicates Parts Available In Assemblies Only)	PART #	QTY.
	<b>BREAKER ASSEMBLY, SAWMILL CONTROL CIRCUIT</b>	015621	1
1	Rail, Circuit Breaker	015310	1
2	Breaker, 15 Amp Manual Reset	E20430	5
3	Screw, #8-32 X 1/2" Slotted Head	F05004-12	6
4	Nut, #8-32 Hex Self-Locking	F05010-41	6
5	<b>BREAKER, 70 AMP MANUAL RESET PANEL MOUNT</b>	015527	1
6	<b>BREAKER, 50 AMP MANUAL RESET PANEL MOUNT</b>	021256	1
7	<b>BOOT, CIRCUIT BREAKER</b>	021253	2
8	<b>SCREW, #10-24 X 3/8" PHILLIPS PAN HEAD</b>	F05004-3	3
9	<b>NUT, #10-24 SELF LOCKING</b>	F05010-14	3

## SECTION 6 UP/DOWN SYSTEM

### 6.1 Up/Down Rollers & Covers

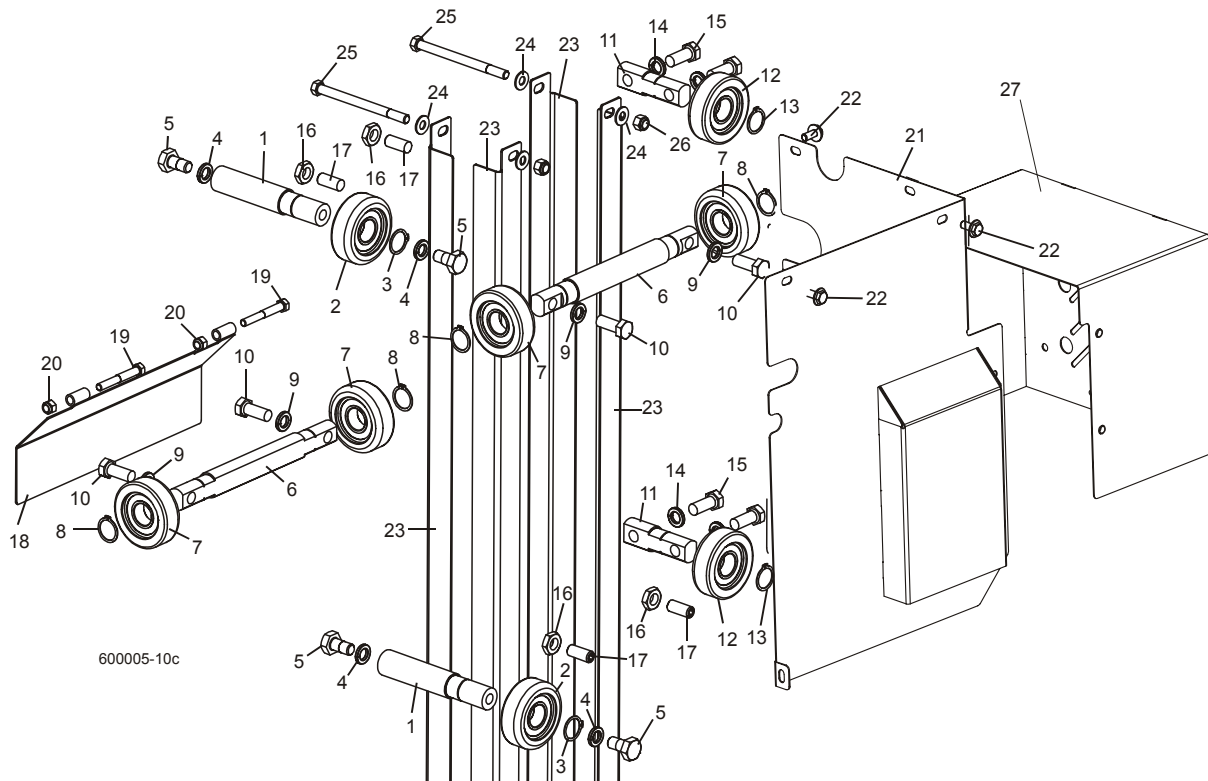

REF	DESCRIPTION (◆ Indicates Parts Available In Assemblies Only)	PART #	QTY.
	<b>ROLLER ASSEMBLY, INSIDE UP/DOWN</b>	089456	2
1	Shaft, Inside Up/Down Roller	088817	1
2	Bearing, CBK-468 Rolling	088433	1
3	Ring, Z30 Spring Retaining	F81090-23	1
4	Washer, 13 Zinc Flat	F81056-1	2
5	Bolt, M12x25-8.8 Hex Head Full Thread Zinc	F81004-31	2
	<b>ROLLER ASSEMBLY, OUTSIDE UP/DOWN</b>	089454	2
6	Shaft, Long Up/Down Roller	088815	1
7	Bearing, CBK-468 Rolling	088433	2
8	Ring, Z30 Spring Retaining	F81090-23	2
9	Washer, 10.5 Zinc Flat	F81055-1	3
10	Bolt, M10x35-8.8 Hex Head Full Thread Zinc	F81003-17	3
	<b>ROLLER ASSEMBLY, SHORT UP/DOWN</b>	089455	2
11	Shaft, Short Up/Down Roller	088816	1
12	Bearing, CBK-468 Rolling	088433	1
13	Ring, Z30 Spring Retaining	F81090-23	1



14	Washer, 10.5 Zinc Flat	F81055-1	2	
15	Bolt, M10x35-8.8 Hex Head Full Thread Zinc	F81003-17	2	
16	<b>NUT, M10-04-W HEX ZINC THIN</b>	F81033-6	4	
17	<b>SCREW, GN 913.3-M10-40-MS SET</b>	F81003-65	4	
18	<b>COVER WELDMENT, UP/DOWN ROLLER</b>	089483-1	1	
19	<b>BOLT, M8X16-8.8-B HEX HEAD FULL THREAD ZINC</b>	F81002-20	4	
20	<b>WASHER, 8.4 ZINC FLAT</b>	F81054-1	9	
21	<b>UP/DOWN GEAR COVER WELDMENT</b>	091319-1	1	
22	<b>BOLT, M8X12-8.8 HEX HEAD FULL THREAD ZINC</b>	F81002-6	5	
23	<b>ANGLE, MAST TUBE STAINLESS</b>	088492	4	
24	<b>WASHER, 10.5 ZINC FLAT</b>	F81055-1	12	
25	<b>BOLT, M10X125-8.8 HEX HEAD ZINC</b>	F81003-18	4	
26	<b>NUT, M10-8-B HEX NYLON ZINC LOCK</b>	F81033-1	4	
27	<b>UP/DOWN MOTOR COVER WELDMENT</b>	090501-1	1	

## 6.2 Blade Height Scale

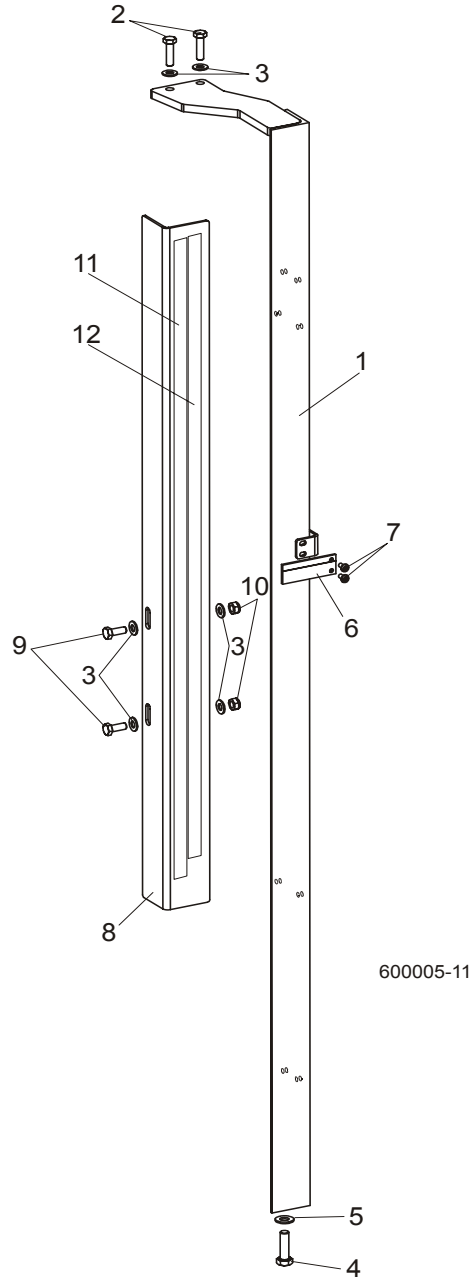

REF	DESCRIPTION (◆ Indicates Parts Available In Assemblies Only)	PART #	QTY.
1	MOUNT WELDMENT, SCALE PAINTED	088554-1	1
2	BOLT, M8 x 30-8.8-B HEX HEAD FULL THREAD ZINC	F81002-7	2
3	WASHER, 8.4 ZINC FLAT	F81054-1	6
4	BOLT, M10 x 35-8.8 HEX HEAD FULL THREAD ZINC	F81003-17	1
5	WASHER, 10.5 ZINC FLAT	F81055-1	1

6	POINTER, BLADE HEIGHT	086691-1	1	
7	SCREW, #10-24 X 3/8 PHILLIPS PAN HEAD ZINC	F05004-3	2	
8	ANGLE, SCALE MOUNT	088785-1	1	
9	BOLT, M8 X 20-8.8-B HEX HEAD FULL THREAD ZINC	F81002-4	2	
10	NUT, M8-8-B HEX NYLON ZINC LOCK	F81032-2	2	
11	DECAL, METRIC SCALE	S11711	1	
12	DECAL, 16-40 MM METRIC SCALE	P12040-1	1	

### 6.3 Up/Down Chain & Sprockets

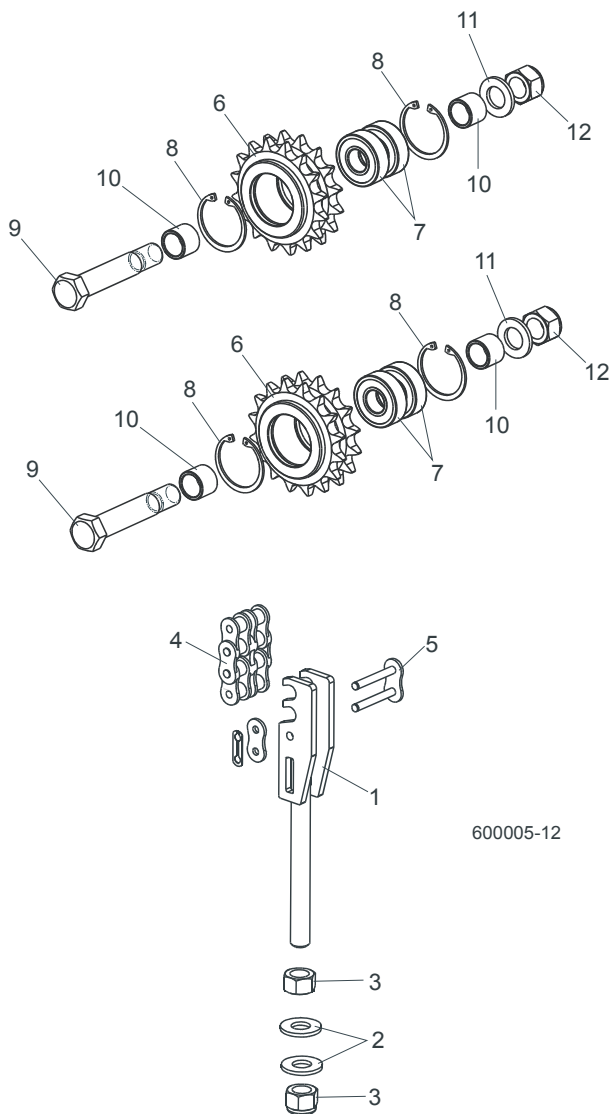

REF	DESCRIPTION (◆ Indicates Parts Available In Assemblies Only)	PART #	QTY.
1	TENSIONER WELDMENT, UP/DOWN CHAIN ZINC	088551-1	1
2	WASHER, 13 ZINC FLAT	F81056-1	2
3	NUT, M12-8 HEX NYLON ZINC LOCK	F81034-2	2
4	CHAIN, 10B-2 113-LINK UP/DOWN	088672	1
5	LINK, 10B-2Pz MASTER	088673	1
	<b>SPROCKET ASSEMBLY, UP/DOWN IDLER</b>	088470	1
6	Sprocket, Zinc	088471-1	1
7	Bearing, 6203-2RS FLT Rolling	086114	2

<b>8</b>	Ring, W40 Spring Retaining	F81090-3	2	
<b>9</b>	Bolt, M16D1F6 x 90-8.8 Hex Fit Short Thread Zinc	F81006-15	1	
<b>10</b>	Spacer, Idler Zinc	088792-1	2	
<b>11</b>	Washer, 17 Zinc Flat	F81058-1	1	
<b>12</b>	Nut, M16-8 Hex Nylon Zinc Lock	F81036-2	1	

### 6.4 Up/Down Drive Assembly

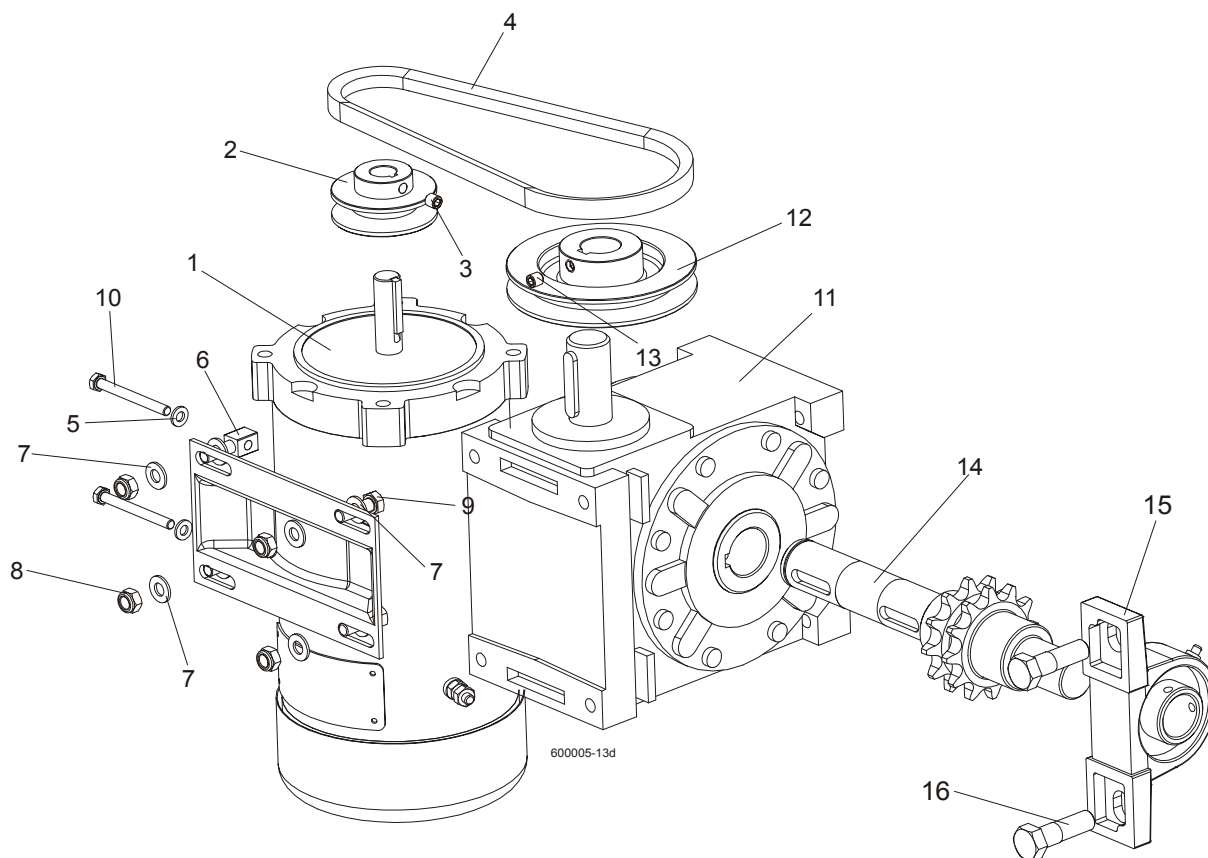

REF	DESCRIPTION (◆ Indicates Parts Available In Assemblies Only)	PART #	QTY.	
	<b>MOTOR W/MOUNT BRACKET, DC UP/DOWN</b>	090492	1	
1	Motor, 2 gear STKg90 6/4L2 IMB14/162	015174	1	
2	Pulley, DC Motor	089528-1	1	
3	Screw, M8x8-33H Hex Socket Set Flat Point Zinc	F81014-1	1	
4	V-Belt, <b>HA-670</b>	<b>091328</b>	1	
5	Washer, 6.4 Zinc Flat	F81053-1	2	
6	Bolt, Special - Zinc Plated	088962-1	2	
7	Washer, 8.4 ZINC FLAT	F81054-1	8	
8	Nut, M8-8-B hex nylon zinc lock	F81032-2	4	
9	Bolt, M8X25-8.8-B hex head full thread zinc	F81002-5	2	
10	Sruba, M6x60-8.8-Fe/Zn5 PN-85/M-82105	F81001-9	2	
	<b>GEAR BOX ASSEMBLY, UP/DOWN DRIVE, RA-08</b>	<b>091310</b>	1	
11	Gear Box, <b>RA-08/64/D1/S,NV5</b>	<b>091306</b>	1	
12	Pulley, Up/Down Gear Painted	<b>091308-1</b>	1	
13	Screw, M8x8-33H Hex Socket Set Flat Point Zinc	<b>F81014-1</b>	1	
14	Output Shaft w/ Sprocket, Up/Down Drive	<b>091311</b>	1	

---

<b>15</b>	Bearings Assembly UCP205 CX	088468	1	
<b>16</b>	<b>Bolt, M12 x 40 - 8.8 Hex Head</b>	F81004-1	2	

## SECTION 7 FEED SYSTEM & TRACK ROLLERS

### 7.1 Upper Track Rollers And Wipers

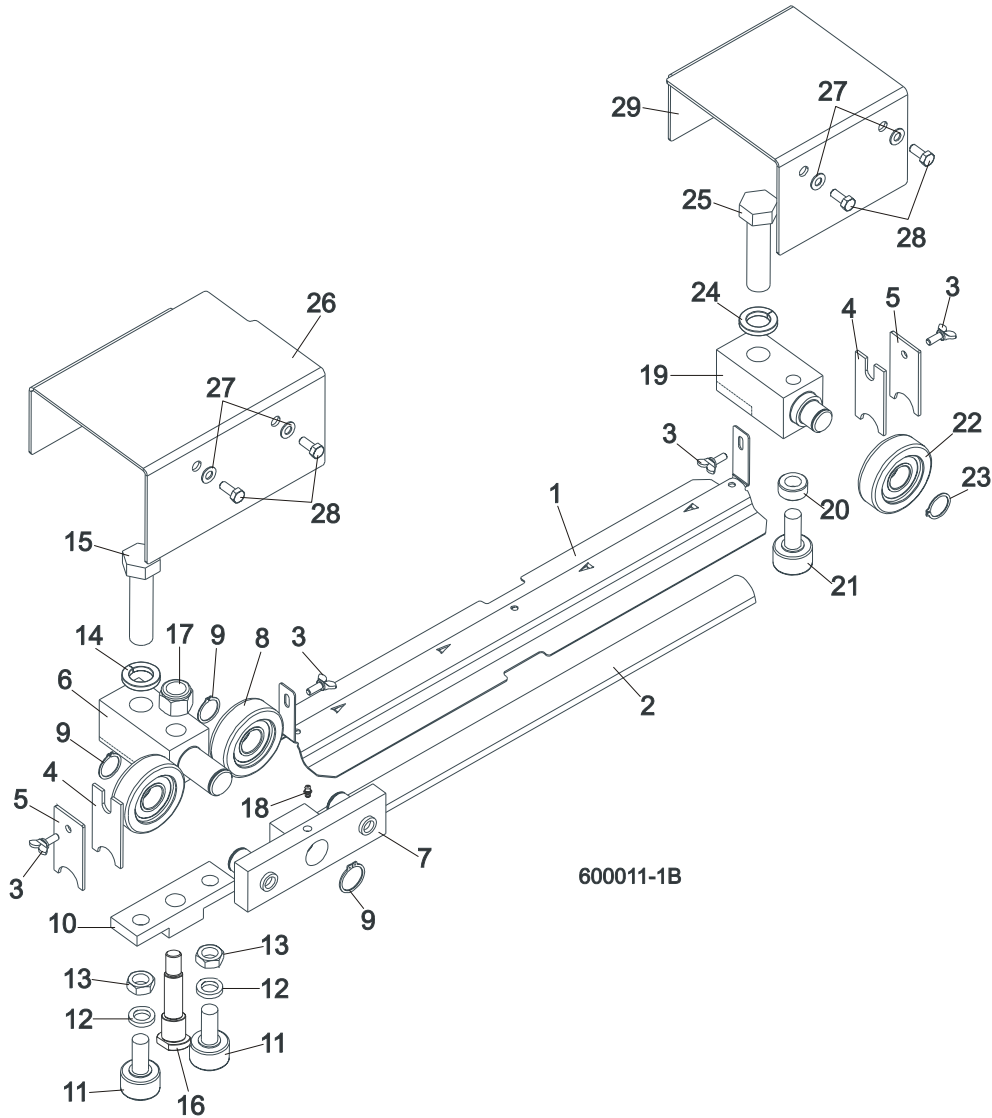

600011-1B

REF	DESCRIPTION (◆ Indicates Parts Available In Assemblies Only)	PART #	QTY.
1	COVER, MIDDLE TRACK	092868-1	1
2	STRIP, FELT	S09915	1
3	SCREW, M6X16 DIN 316 WING	F81001-16	4
4	WIPER, TOP RAIL	M04113	2
5	PLATE, TRACK WIPER	088559-1	2
	ROLLER ASSEMBLY, UPPER TANDEM TRACK	088530	1
6	Block, Tandem Roller Mount	088532	1



## Feed System & Track Rollers

### *Upper Track Rollers And Wipers*

7

7	Block Assembly, Tandem Roller	088533	1	
8	Roller, CBK-468	088433	2	
9	Ring, Z30 Spring Retaining	F81090-23	2	
10	Block, Cam Follower Mount	088520	1	
11	Bearing, Cam Follower (McGill)	012797	2	
12	Washer, 16.3 Split Zinc Lock	F81058-2	2	
13	Nut, 5/8"-18 Zinc	F05010-11	2	
14	Washer, Z24.5 Split Zinc Lock	F81061-4	1	
15	Bolt, M24 x 2 x 90-8.8 Hex Head Full Thread Zinc	F81009-2	1	
16	Pin, Cam Follower Mount	088531	1	
17	Nut, M16-8 Hex Nylon Zinc Lock	F81036-2	1	
18	Fitting, M6 Straight Grease	086280	1	
	<b>ROLLER ASSEMBLY, REAR UPPER TRACK</b>	088529	1	
19	Block, Rear Upper Roller Mount	088528	1	
20	Spacer, Cam Follower	088536	1	
21	Bearing, Cam Follower (McGill)	012797	1	
22	Roller, CBK-468	088433	1	
23	Ring, Z30 Spring Retaining	F81090-23	1	
24	Washer, Z24.5 Split Zinc Lock	F81061-4	1	
25	Bolt, M24x2x90-8.8 Hex Head Full Thread Zinc	F81009-2	1	
26	<b>COVER, TANDEM ROLLER</b>	088526	1	
27	<b>WASHER, 6.4 ZINC FLAT</b>	F81053-1	4	
28	<b>BOLT, M6X16 8.8 HEX HEAD FULL THREAD ZINC</b>	F81001-15	4	
29	<b>COVER, REAR UPPER ROLLER</b>	088527	1	

# 7 Feed System & Track Rollers

## Power Feed Assembly

### 7.2 Power Feed Assembly

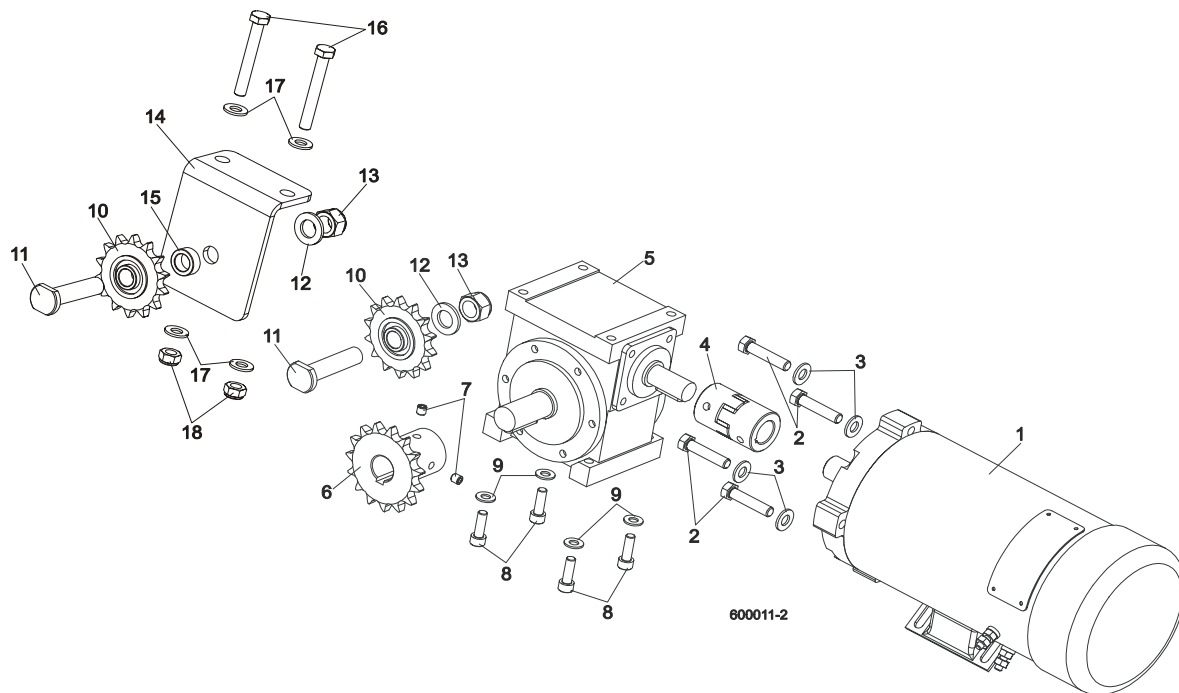

REF	DESCRIPTION (◆ Indicates Parts Available In Assemblies Only)	PART #	QTY.
1	MOTOR, 12V, 0.75KM LEESON	024169	1
2	BOLT, 3/8-16x1 3/4 HEX HEAD FULL THREAD	F05007-19	4
3	WASHER, 10.5 ZINC FLAT	F81055-1	4
4	COUPLING, SPIDEX 19/ 5/8" b/b ST 92Sh	090786	1
5	GEAR BOX, RA-05/7,5/D1/S+N/B8 W/OUTPUT SHAFT	088578	1
6	SPROCKET, 10B Z15 ZINC	088541-1	1
7	SCREW, M8x8-33H HEX SOCKET SET FLAT POINT ZINC	F81014-1	2
8	SCREW, M8x25 -8.8 HEX SOCKET HEAD CAP ZINC	F81002-21	4
9	WASHER, 8.4 ZINC FLAT	F81054-1	4
10	SPROCKET, KSR 16.L0.10.10.14.08 W/BEARING	088867	2
11	PIN, ZINC SPROCKET MOUNT	088994-1	2
12	WASHER, 17 ZINC FLAT	F81058-1	2
13	NUT, M16-8 HEX NYLON ZINC LOCK	F81036-2	2
14	BRACKET, POWER FEED SPROCKET MOUNT	088507-1	1
15	SPACER, POWER FEED SPROCKET	088550-1	1
16	BOLT, M10x75-8.8 HEX HEAD ZINC	F81003-15	2
17	WASHER, 10.5 ZINC FLAT	F81055-1	4
18	NUT, M10-8-B HEX NYLON ZINC LOCK	F81033-1	2

### 7.3 Feed Chain/Stop, LT60HD/LT70HD

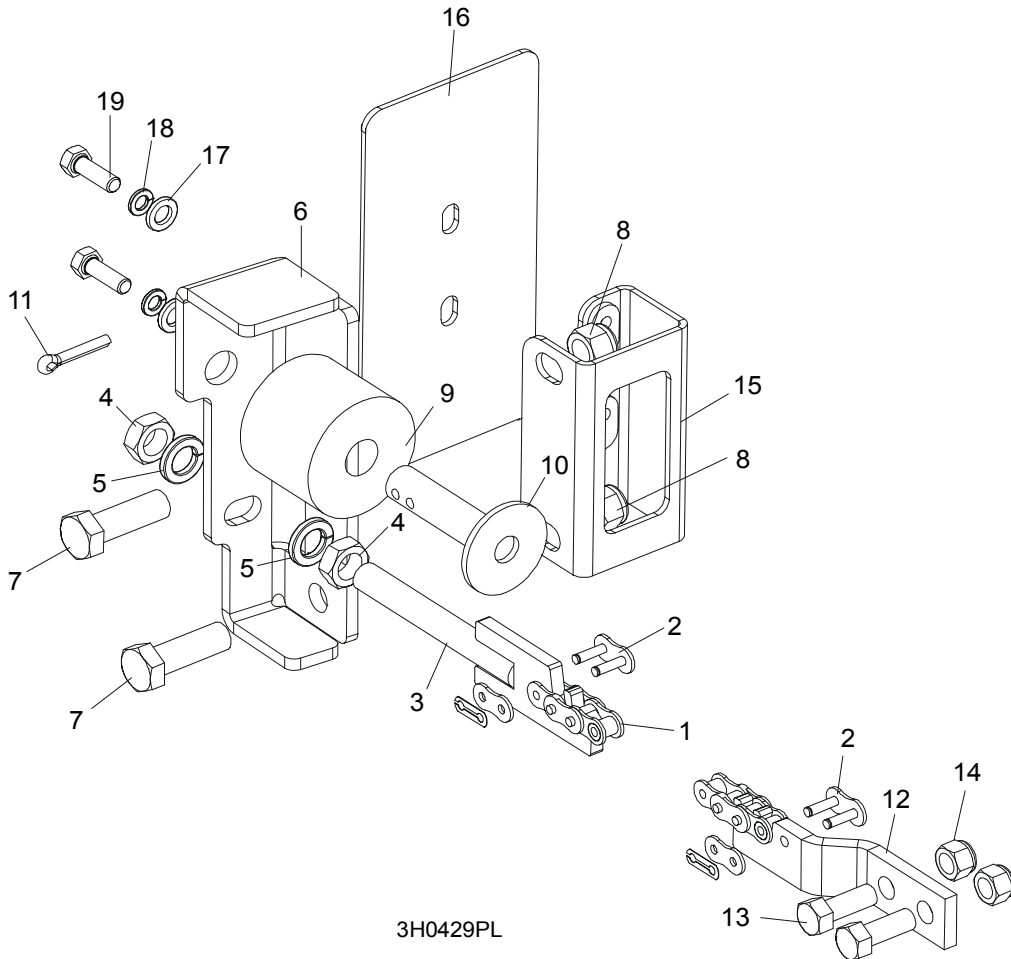

3H0429PL

REF	DESCRIPTION (◆ Indicates Parts Available In Assemblies Only)	PART #	QTY.
	<b>CHAIN KIT, LT30 FEED</b>	K10408	1
	<b>CHAIN KIT, LT40 FEED</b>	K10410	1
1	Chain, #40 X 215" LT30 Feed	014744	1
	Chain, #40 X 267.5" LT40 Feed	014475	1
2	Link, #40 Master	P04200	2
3	Tensioner Weldment, Power Feed Chain	086818-1	1
4	Nut, M12-5 Hex Jam	F81034-4	2
5	Washer, 12.2 Split Lock	F81056-2	2
6	<b>BRACKET, FEED CHAIN REAR MOUNT</b>	087628-1	1
7	<b>BOLT, M12 X 40 8.8 HEX HEAD GRADE 5</b>	F81004-4	2
8	<b>NUT, M12-8 HEX NYLON LOCK</b>	F81034-2	2
	<b>STOP KIT, RUBBER CARRIAGE</b>	K09630	2
9	Stop, Rubber Carriage	P12165	1

## **7** Feed System & Track Rollers

*Feed Chain/Stop, LT60HD/LT70HD*

---

10	Pin, Rubber Carriage Stop	W09293	1	
11	Pin, 3/16" X 1" Cotter	F05012-21	1	
12	<b>BRACKET, FRONT FEED CHAIN MOUNT</b>	015008	1	
13	<b>BOLT, 3/8-16 X 1" HEX HEAD</b>	F05007-7	2	
14	<b>NUT, 3/8-16 HEX NYLON LOCK</b>	F05010-10	2	
15	<b>BRACKET WELDMENT, REAR MAIN TUBE COVER MOUNT</b>	087105-1	1	
16	<b>COVER, REAR MAIN TUBE</b>	015023	1	
17	<b>WASHER, 8.4 FLAT</b>	F81054-1	2	
18	<b>WASHER, 8.2 SPLIT LOCK</b>	F81054-4	2	
19	<b>BOLT, 5/16-18 X 1" HEX HEAD</b>	F05006-1	2	

### 7.4 Lower Track Rollers

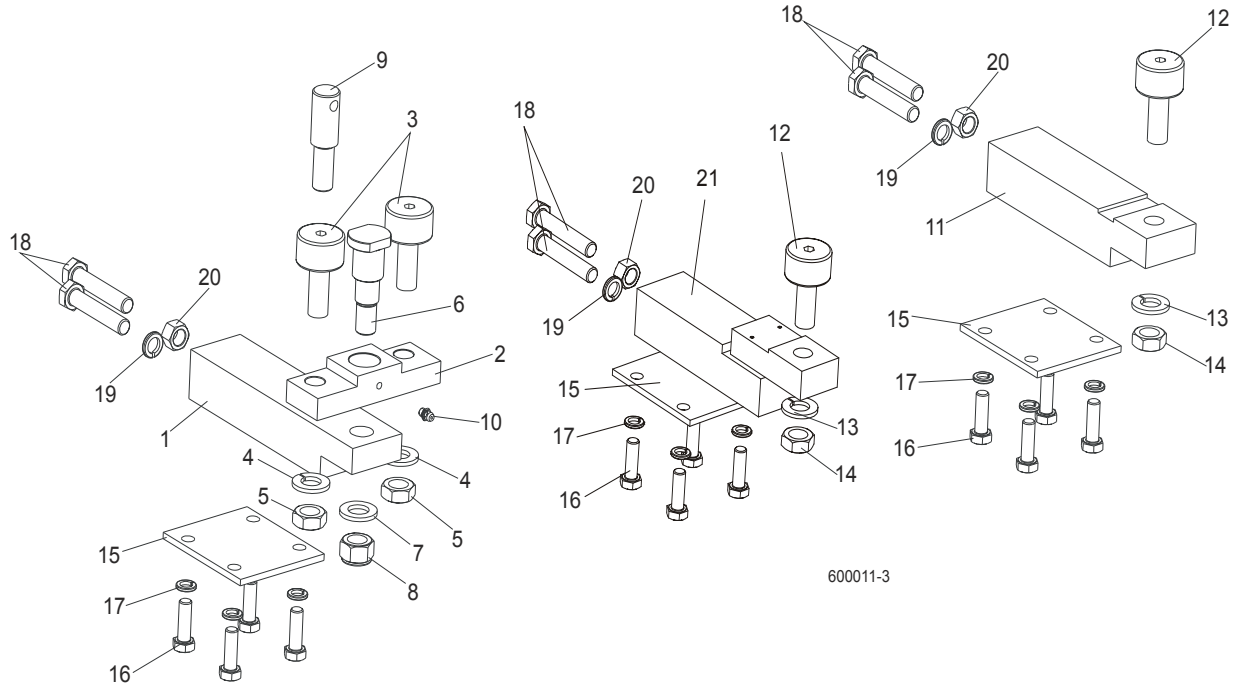

600011-3

REF	DESCRIPTION (◆ Indicates Parts Available In Assemblies Only)	PART #	QTY.
	<b>BLOCK ASSEMBLY, VERTICAL MAST ALIGNMENT DOUBLE</b>	088523	1
1	Block, Vertical Mast Alignment Double	088517	1
2	Block, Cam Follower Mount	088520	1
3	Bearing, Cam Follower (McGill)	012797	2
4	Washer, 16.3 Split Zinc Lock	F81058-2	2
5	Nut, 5/8"-18 Zinc	F05010-11	2
6	Pin, Cam Follower Mount	088521	1
7	Washer, 17 Zinc Flat	F81058-1	1
8	Nut, M16-8 Hex Nylon Zinc Lock	F81036-2	1
9	Pin, Safety Lock	088519	1
10	Fitting, M6 Straight Grease	086280	1
	<b>BLOCK ASSEMBLY, VERTICAL MAST ALIGNMENT SINGLE</b>	088524	1
11	Block, Vertical Mast Alignment Single	088518	1
12	Bearing, Cam Follower (McGill)	012797	1
13	Washer, 16.3 Split Zinc Lock	F81058-2	1
14	Nut, 5/8"-18 Zinc	F05010-11	1
15	<b>PLATE, LOWER TRACK ROLLER RETAINER</b>	088516	2
16	<b>BOLT, M10X30-5.8 HEX HEAD FULL THREAD ZINC</b>	F81003-2	8
17	<b>WASHER, 10.2 SPLIT ZINC LOCK</b>	F81055-2	8
18	<b>BOLT, M12X1.25X65-8.8 HEX HEAD FULL THREAD ZINC</b>	F81004-40	4
19	<b>WASHER, Z12.2 SPLIT ZINC LOCK</b>	F81056-2	2

# **7** Feed System & Track Rollers

*Lower Track Rollers*

---

<b>20</b>	<b>NUT, M12X1.25-8 ZINC HEX</b>	F81034-8	2	
<b>21</b>	<b>LOWER ROLLER BRACKET</b>	091425	1	

## SECTION 8 BED FRAME ASSEMBLY

### 8.1 Bed Rail Assembly, Front And Rear

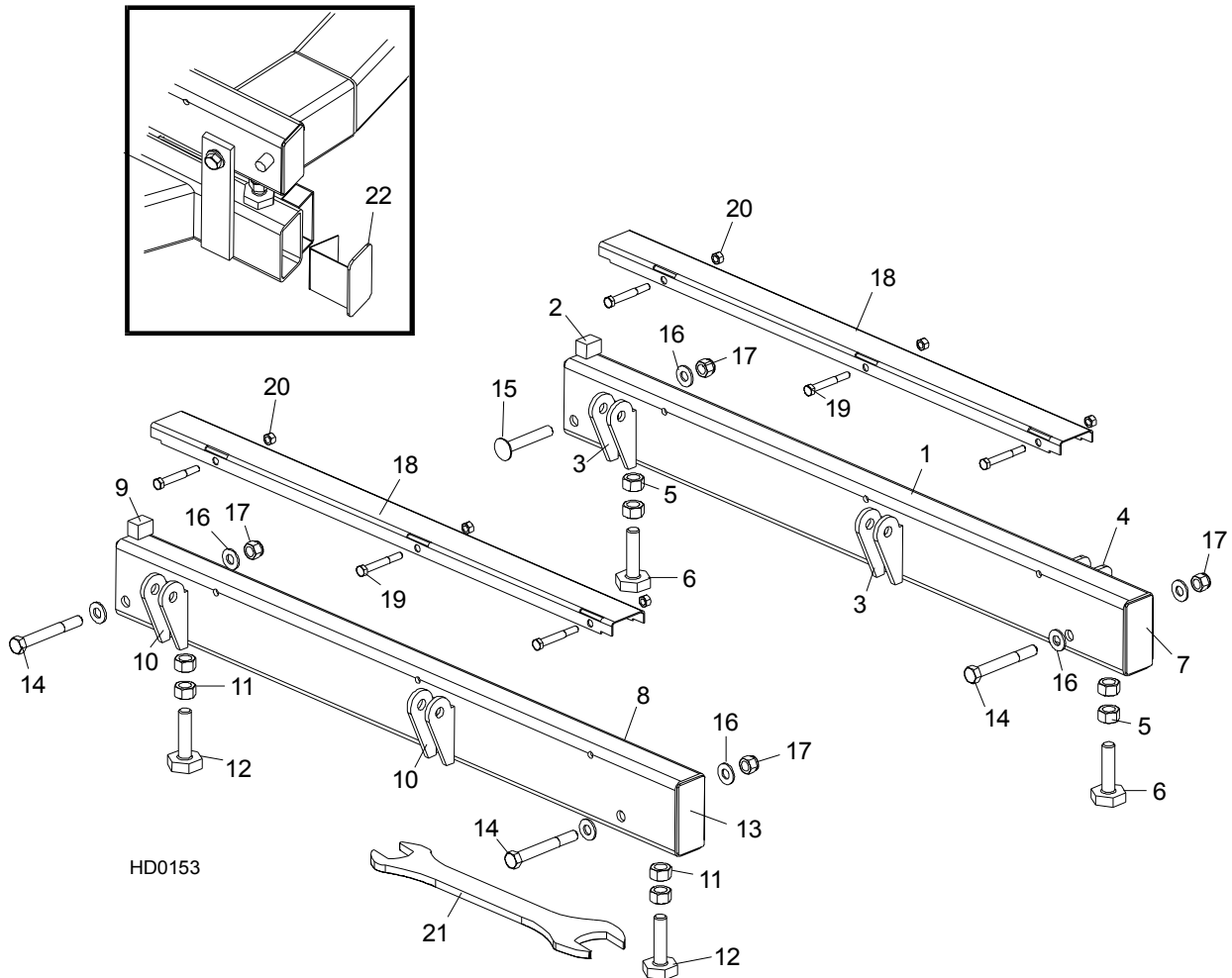

REF	DESCRIPTION (◆ Indicates Parts Available In Assemblies Only)	PART #	QTY.	
	<b>BED RAIL ASSEMBLY, REAR PAINTED</b>	014467	1	
1	Bed Rail Tube, Long	015974	1	◆
2	Block, Log Stop	S09034	1	
3	Bracket, Roller Toe Board Mount	S13021	4	◆
4	Bracket, Saw Head Rest Pin Mount	014150	2	◆
	Bolt Assembly, Bed Rail	086809	2	◆
5	Nut, 5/8-11 Hex	F05010-54	2	
6	Bolt, Bed Rail Adjustment	S13006	1	
7	Plate, Bed Rail End Cap	S04058	2	◆

## 8

**Bed Frame Assembly***Bed Rail Assembly, Front And Rear*

	<b>BED RAIL ASSEMBLY, FRONT PAINTED</b>	014455	1	
8	Bed Rail Tube, Long	015974	1	◆
9	Block, Log Stop	S09034	1	
10	Bracket, Roller Toe Board Mount	S13021	4	◆
	Bolt Assembly, Bed Rail	086809	2	◆
11	Nut, 5/8-11 Hex	F05010-54	2	
12	Bolt, Bed Rail Adjustment	S13006	1	
13	Plate, Bed Rail End Cap	S04058	2	◆
14	<b>BOLT, M12 X 100-8.8 HEX HEAD</b>	F81004-3	3	
15	<b>BOLT, 1/2-13 X 3 1/2" CARRIAGE</b>	F05008-94 <sup>1</sup>	1	
16	<b>WASHER, 13 FLAT</b>	F81056-1	7	
17	<b>NUT, M12-8 NYLON LOCK</b>	F81034-2	4	
	<b>COVER ASSEMBLY, STAINLESS STEEL BED RAIL (LONG)</b>	A09956	2	
18	Cover, Stainless Steel Bed Rail	S09944	1	◆
19	Bolt, 5/16-18 X 2 1/2" Hex Head	F05006-10	3	
20	Nut, 5/16-18 Hex Lock	F05010-6	3	
21	<b>WRENCH, BED RAIL ADJUSTMENT</b>	015970	1	
22	<b>CAP WELDMENT, BED RAIL REMOVABLE END</b>	014652	2	

<sup>1</sup> Used on rear bed rail to allow clearance for side support rollers.



## 8.2 Bed Rail Assembly, Front Middle

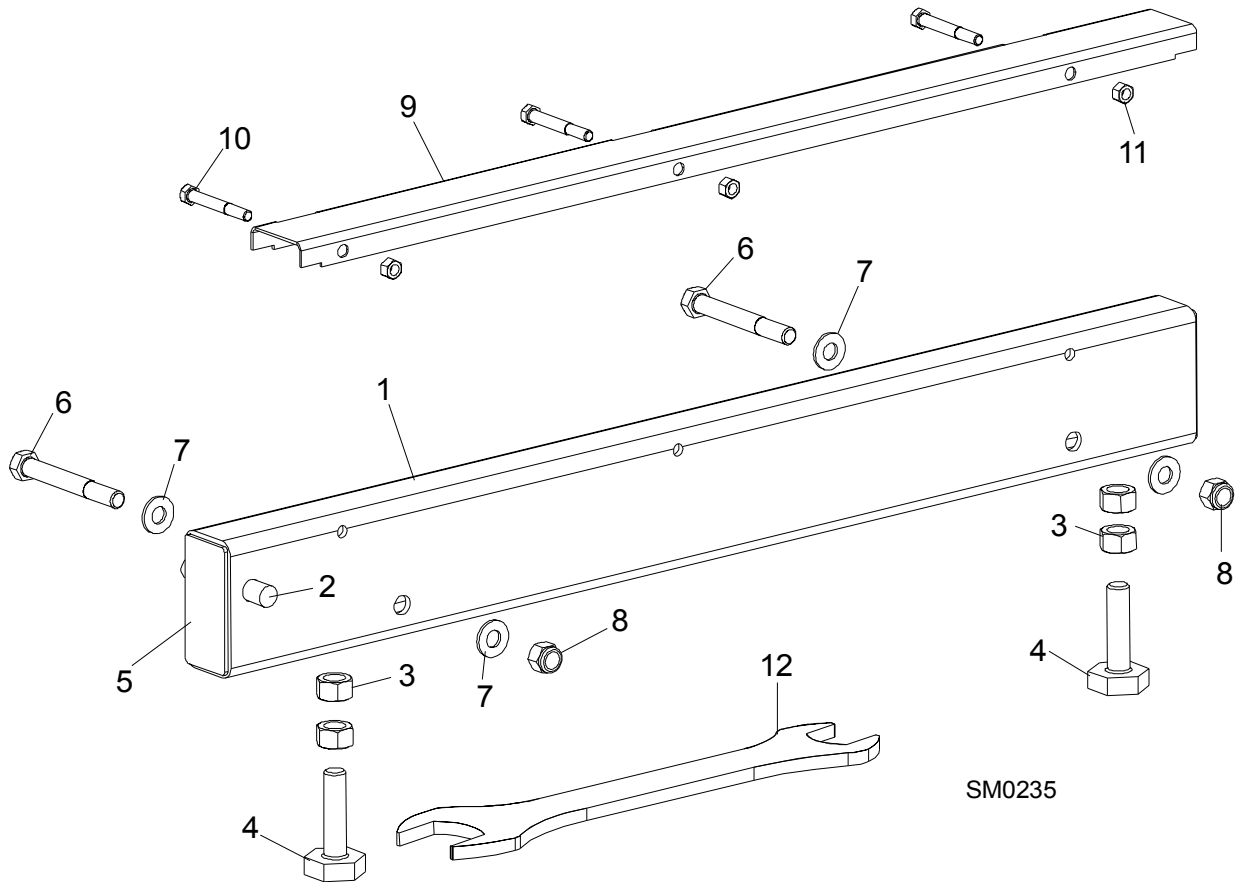

REF	DESCRIPTION (◆ Indicates Parts Available In Assemblies Only)	PART #	QTY.	
	<b>BED RAIL ASSEMBLY, FRONT MIDDLE</b>	A09566	1	
1	Bed Rail Tube, Short	S09103	1	◆
2	Pin, Ramp Mount	S04030	1	
	Bolt Assembly, Bed Rail	086809	2	◆
3	Nut, 5/8-11 Hex	F05010-54	2	
4	Bolt, Bed Rail Adjustment	S13006	2	
5	Plate, Bed Rail End Cap	S04058	2	◆
6	<b>BOLT, M12 X 100-8.8 HEX HEAD</b>	F81004-3	2	
7	<b>WASHER, 13 FLAT</b>	F81056-1	4	
8	<b>NUT, M12-8 HEX NYLON LOCK</b>	F81034-2	2	
	<b>COVER ASSEMBLY, STAINLESS STEEL BED RAIL (LONG)</b>	A09956	1	
9	Cover, Stainless Steel Bed Rail	S09944	1	◆
10	Bolt, M8x65-5,8 Zinc Hex Head	F81002-3	3	
11	Nut, M8-8-B-Zinc Hex Nylon Lock	F81032-2	3	



## Bed Frame Assembly

### *Bed Rail Assembly, Front Middle*

---

12	WRENCH, BED RAIL ADJUSTMENT	015970	1	
----	-----------------------------	--------	---	--

**8.3 Bed Rail Assembly, Rear Middle**

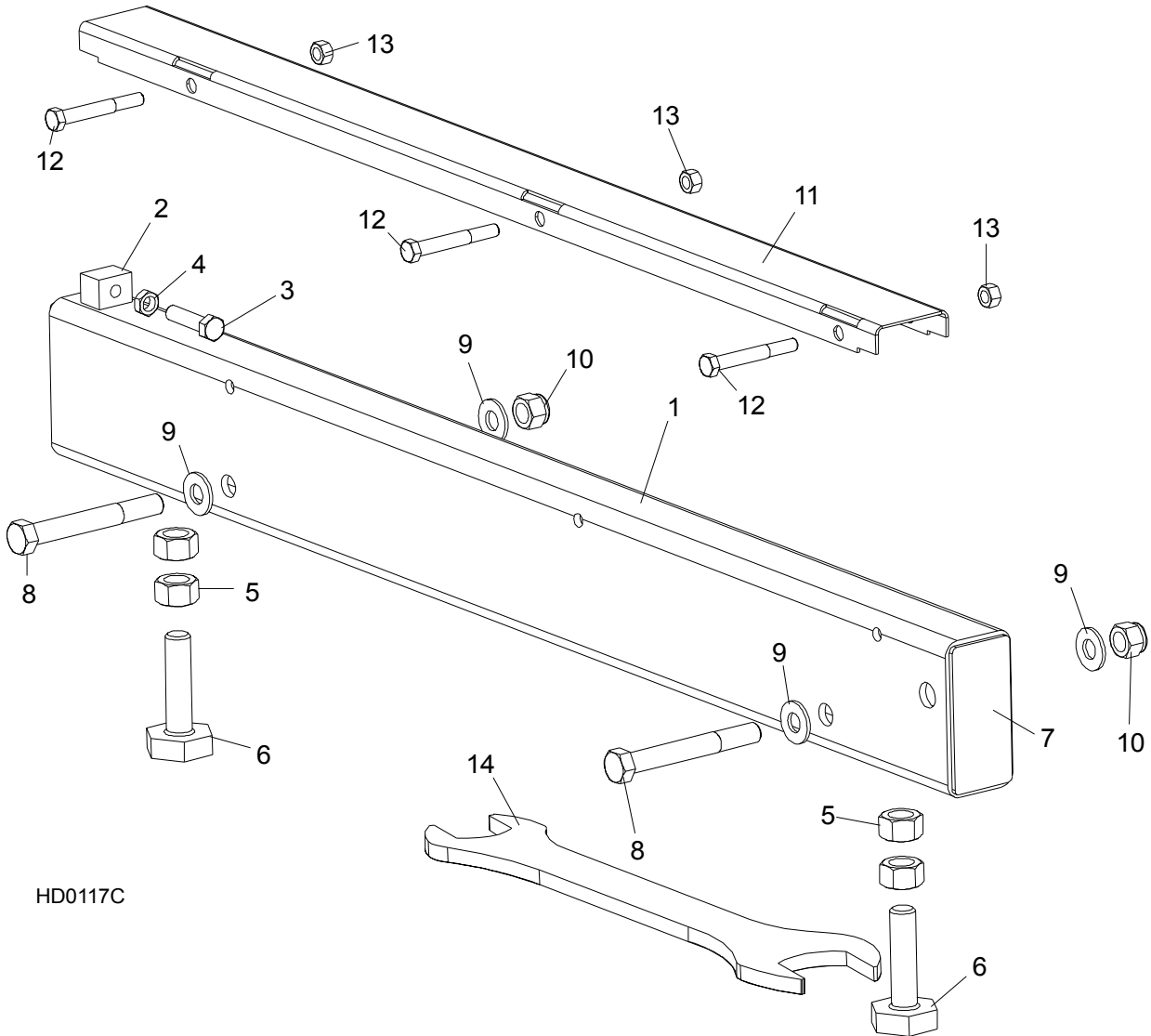

REF	DESCRIPTION (◆ Indicates Parts Available In Assemblies Only)	PART #	QTY.	
	<b>BED RAIL ASSEMBLY, REAR MIDDLE PAINTED</b>	015757	1	
1	Bed Rail Tube, Short	014640	1	◆
2	Block, Log Stop w/Threaded Hole	014639	1	◆
3	Bolt, 3/8-16 x 1 1/2 Full Thead Hex Head	F05007-17	1	
4	Nut, 3/8-16 Hex Jam	F05010-29	1	
	Bolt Assembly, Bed Rail	086809	2	◆
5	Nut, 5/8-11 Hex	F05010-54	2	
6	Bolt, Bed Rail Adjustment	S13006	2	

# 8

## Bed Frame Assembly

### *Bed Rail Assembly, Rear Middle*

7	Plate, Bed Rail End Cap	S04058	2	◆
8	<b>BOLT, M12 X 100-8.8 HEX HEAD</b>	F81004-3	2	
9	<b>WASHER, 13 FLAT</b>	F81056-1	4	
10	<b>NUT, M12-8 NYLON LOCK</b>	F81034-2	2	
	<b>COVER ASSEMBLY, STAINLESS STEEL BED RAIL (LONG)</b>	A09956	1	
11	Cover, Stainless Steel Bed Rail	S09944	1	◆
12	Bolt, 5/16-18 X 2 1/2" Hex Head	F05006-10	3	
13	Nut, 5/16-18 Hex Lock	F05010-6	3	
14	<b>WRENCH, BED RAIL ADJUSTMENT</b>	015970	1	

8.4 Leg, Stationary

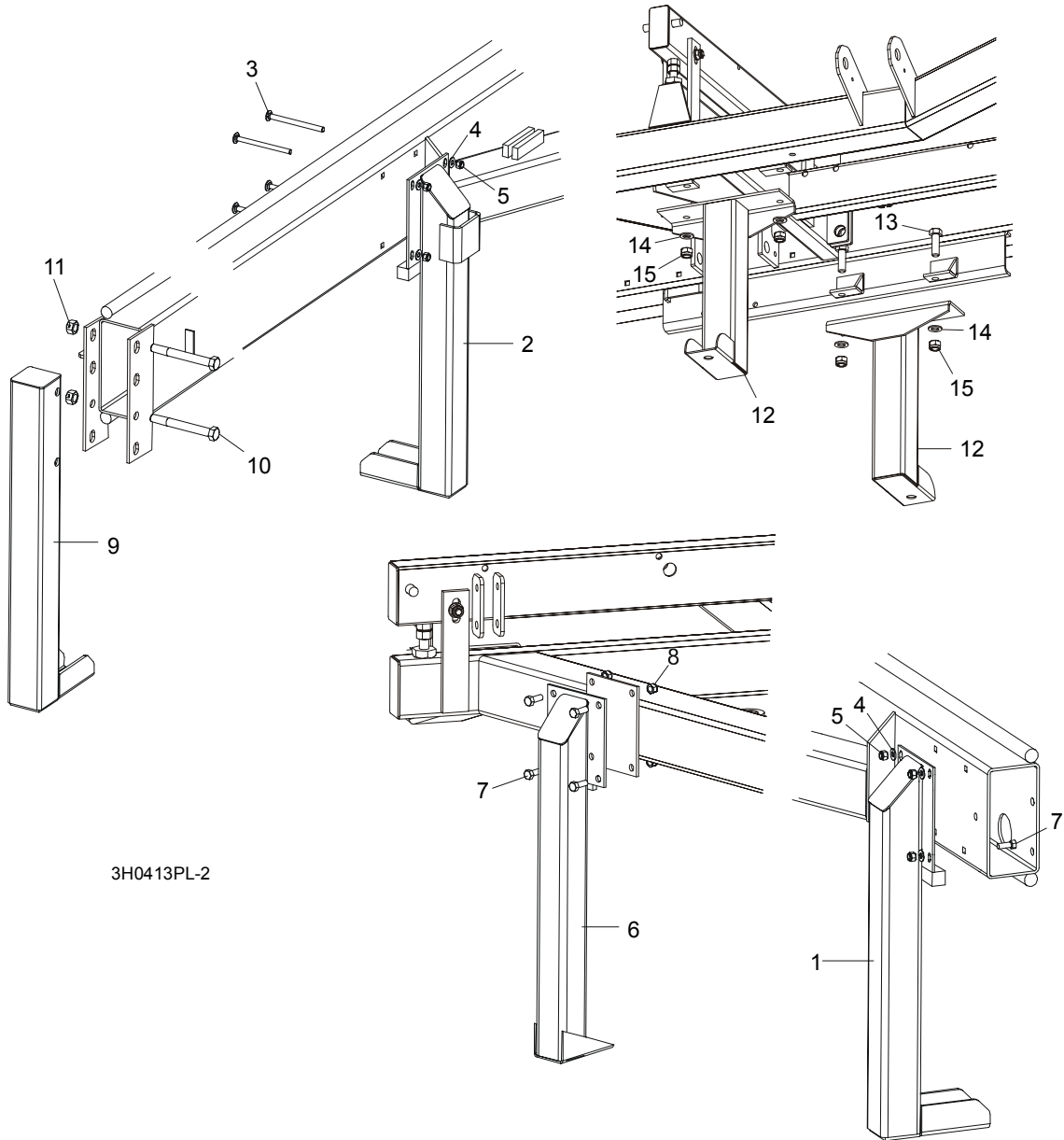

3H0413PL-2

REF	DESCRIPTION (◆ Indicates Parts Available In Assemblies Only)	PART #	QTY.
1	LEG, LONG RIGHT STATIONARY (1 REQ'D FOR LT30; 3 REQ'D FOR LT40)	087451-1	1/3
2	LEG, LONG STATIONARY W/BOARD RETURN TABLE BRACKET	087449-1	1
3	BOLT, M10 X 120-8.8 CARRIAGE HEAD	F81003-33	8/12
4	WASHER, 10.5 FLAT	F81055-1	8/16
5	NUT, M10-8-B HEX NYLON LOCK	F81033-1	8/16

**8****Bed Frame Assembly***Leg, Stationary*

---

6	LEG, SHORT LEFT STATIONARY	087450-1	2	
7	BOLT, M10 X 25-8.8 HEX HEAD	F81003-11	12	
8	NUT, M10-8-B HEX NYLON LOCK	F81033-1	12	
9	LEG, FRONT STATIONARY	087452-1	1	
10	BOLT, M16 X 140-8.8 HEX HEAD GRADE 5	F81006-4	2	
11	NUT, M16-8 HEX LOCK	F81036-2	2	
12	LEG, MIDDLE STATIONARY	087093-1	2	
13	BOLT, M16 X 50-8.8 HEX HEAD	F81006-7	4	
14	WASHER, 17 FLAT	F81058-1	4	
15	NUT, M16 NYLON LOCK	F81036-2	4	

### 8.5 Pivot Bed Rail Assembly

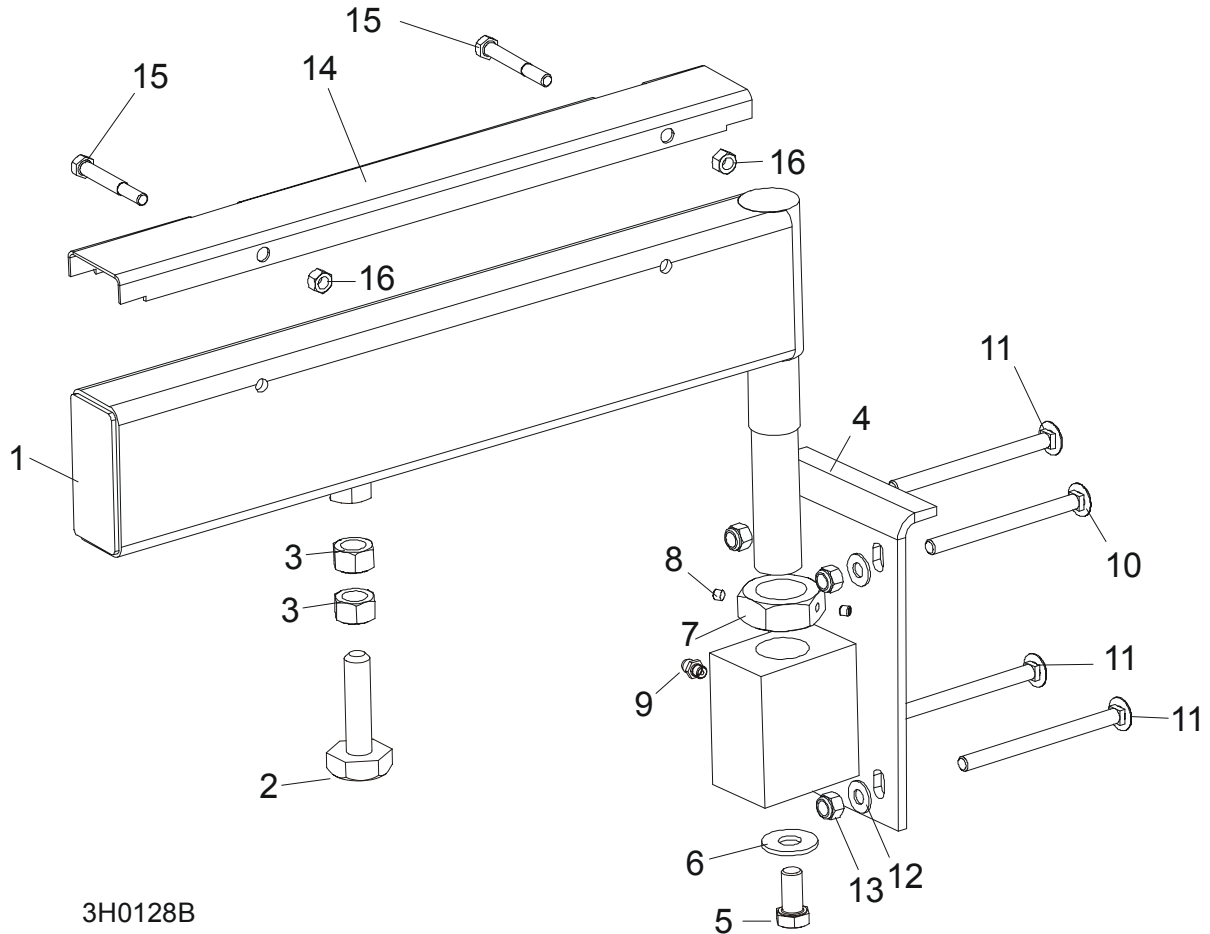

3H0128B

REF	DESCRIPTION (◆ Indicates Parts Available In Assemblies Only)	PART #	QTY.
	PIVOT BED RAIL ASSEMBLY ( )	087829	2
	PIVOT BED RAIL ASSEMBLY ( )	087855	2
1	Pivot Bed Rail Weldment ( )	087852	1
	Pivot Bed Rail Weldment ( )	087848	1
	Bolt Assembly, Bed Rail Adjustment		1
2	Bolt, Bed Rail Adjustment	086809	1
3	Nut, 5/8-11 Hex	F81036-1	2
4	Bracket, Pivot Rail Mounting	087841-1	1
5	Bolt, 1/2-13 x 1" Hex Head Grade 2	F81004-31	1
6	Washer, 15 Flat	F05011-52	1
7	Nut, Pivot Rail Adjustment ( )	F81036-1	1
	Nut, Pivot Rail Adjustment ( )	F81039-2	

## 8

**Bed Frame Assembly***Pivot Bed Rail Assembly*

8	Screw, 1/4-28 x 1/4" Brass Tip Set	F05005-42	2	
9	Fitting, 3/16" Grease	086280	1	
10	<b>BOLT, 3M10 X 120-8.8 CARRIAGE HEAD</b>	F81003-14	2	
11	<b>BOLT, 3/8-16 X 5" CARRIAGE HEAD</b>	F05007-113	6	
12	<b>WASHER,10.5 FLAT</b>	F81055-1	8	
13	<b>NUT, M16-8 NYLON LOCK</b>	F81036-2	8	
	<b>COVER KIT, PIVOT RAIL STAINLESS STEEL ()</b>	015926	2	
	<b>COVER KIT, PIVOT RAIL STAINLESS STEEL ()</b>	N/A	2	
14	Cover, Stainless Steel Pivot Bed Rail ()	012994	1	
	Cover, Stainless Steel Pivot Bed Rail ()	S13012	1	
15	Bolt, M8x65-5,8 Zinc Hex Head	F81002-3	4	
16	Nut, M8-8-B-Zinc Hex Nylon Lock	F81032-2	4	
	<b>WRENCH, BED RAIL ADJUSTMENT (<a href="#">See Section 8.3</a>)</b>	015970	1	



### 8.6 Log Side Support Assembly (Manual)

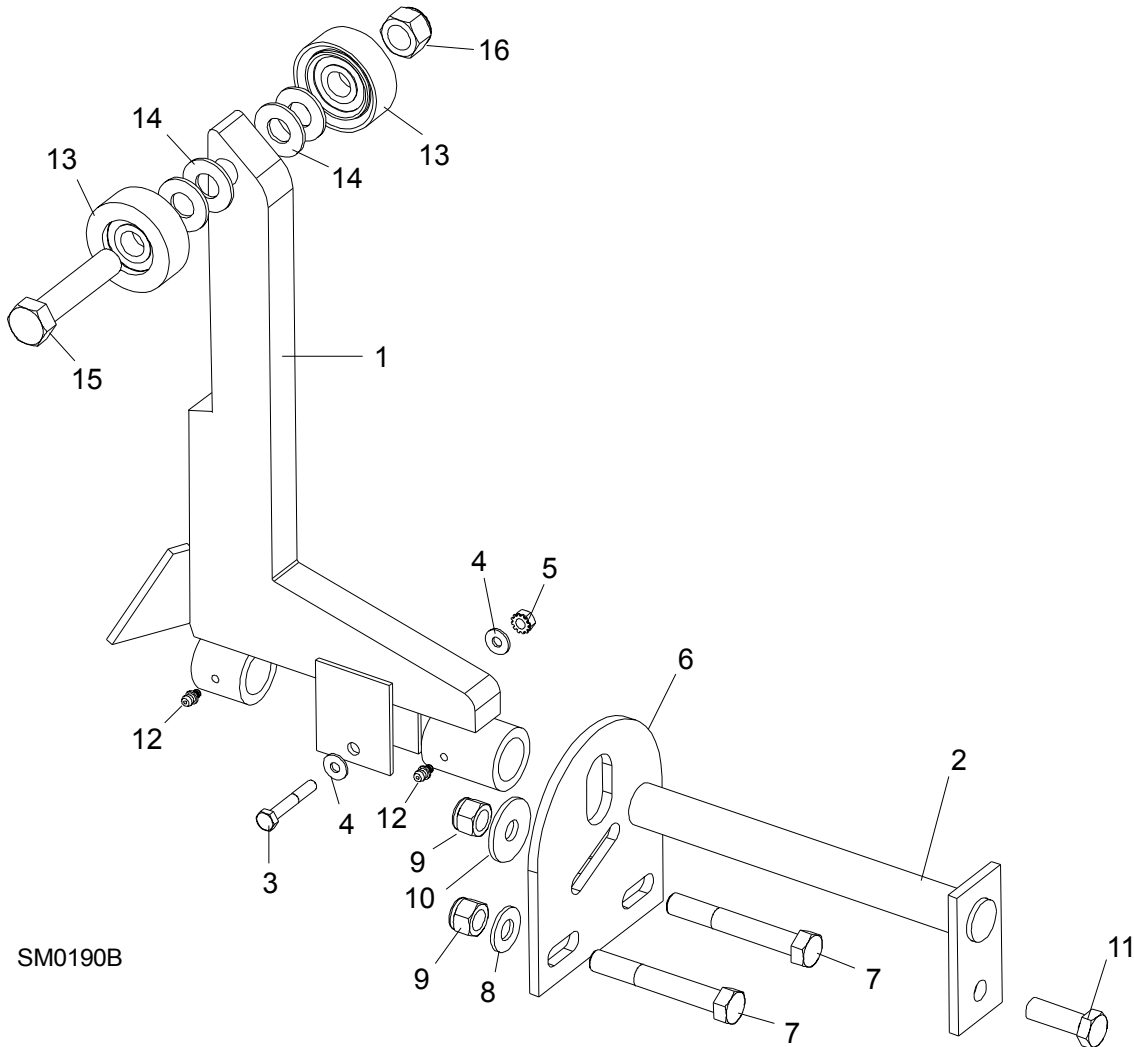

REF	DESCRIPTION (◆ Indicates Parts Available In Assemblies Only)	PART #	QTY.
1	<b>SUPPORT, LOG SIDE</b>	085538	
	<b>MOUNTING KIT, LOG SIDE SUPPORT</b>	K09440	
2	Pin, Log Side Support Pivot	W09238-1	1
3	Bolt, 1/4-20 X 1 1/2" Hex Head Grade 5	F05005-4	1
4	Washer, 7.4 Flat	F81056-11	2
5	Nut, 1/4-20 Self Locking	F05010-9	1
6	Plate, Log Side Support End	S09148	1
7	Bolt, M12 x 90-8.8 Hex Head	F81004-2	2
8	Washer, 13 Flat	F81056-1	2

## 8

**Bed Frame Assembly***Log Side Support Assembly (Manual)*

---

<b>9</b>	Nut, M12-8 Hex Nylon Lock	F81034-2	3	
<b>10</b>	Washer, .5" x 1.63" x 11" Ga.	086184	1	
<b>11</b>	Bolt, M12 x 35-8.8 Hex Head	F81004-11	1	
<b>12</b>	<b>FITTING, 3/16" GREASE</b>	P04107	2	
	<b>ROLLER KIT, SIDE SUPPORT (OPTIONAL)</b>	015109	4	
<b>13</b>	Roller Assembly, Side Support	015014-1	2	
<b>14</b>	Washer, 17 Flat	F81058-1	4	
<b>15</b>	Bolt, 5/8-11 x 3" Hex Head Grade 5	F05009-37	1	
<b>16</b>	Nut, 5/8-11 Nylon Lock	F05010-34	1	
	Instruction Sheet, Side Support Roller	015109-526	1	

## 8.7 Tie Down Chain Assembly

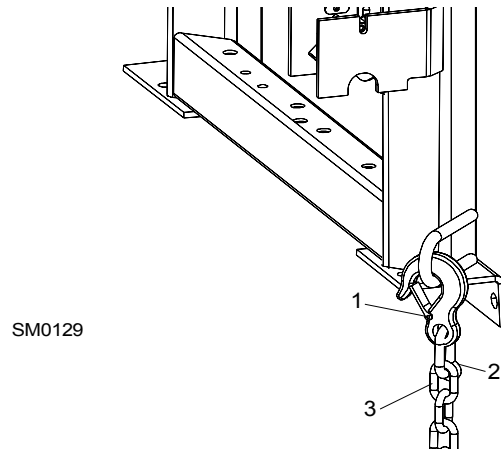

REF	DESCRIPTION (◆ Indicates Parts Available In Assemblies Only)	PART #	QTY.	
	<b>CHAIN ASSEMBLY, TIE DOWN</b>	A04376	1	
<b>1</b>	Hook, 5/8" Safety Chain	P12075	1	◆
<b>2</b>	Cold Shut, 3/8" Plain	P04772-2	1	◆
<b>3</b>	Chain, N-10 x 35 Unplated	R80558	.28 m	◆

**8** **Bed Frame Assembly**  
*Saw Head Rest Pin Assembly*

**8.8 Saw Head Rest Pin Assembly**

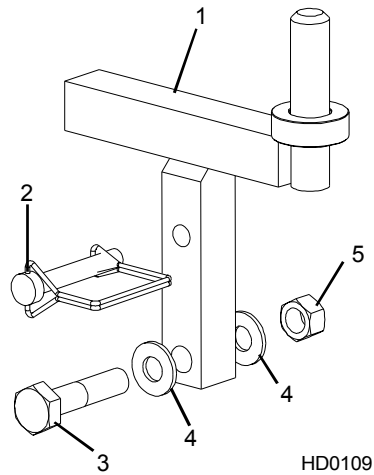

REF	DESCRIPTION (◆ Indicates Parts Available In Assemblies Only)	PART #	QTY.
1	PIN, SAW HEAD REST	085949	1
2	PIN, 3/8" X 2 1/4" SNAP RETAINER	014151	1
3	BOLT, M12 X 60-8.8 HEX HEAD GRADE 5	F81004-5	1
4	WASHER, 13 SAE FLAT	F81056-1	2
5	NUT, 1/2-13 HEX LOCK	F05010-3	1

### 8.9 Bed Frame Decals

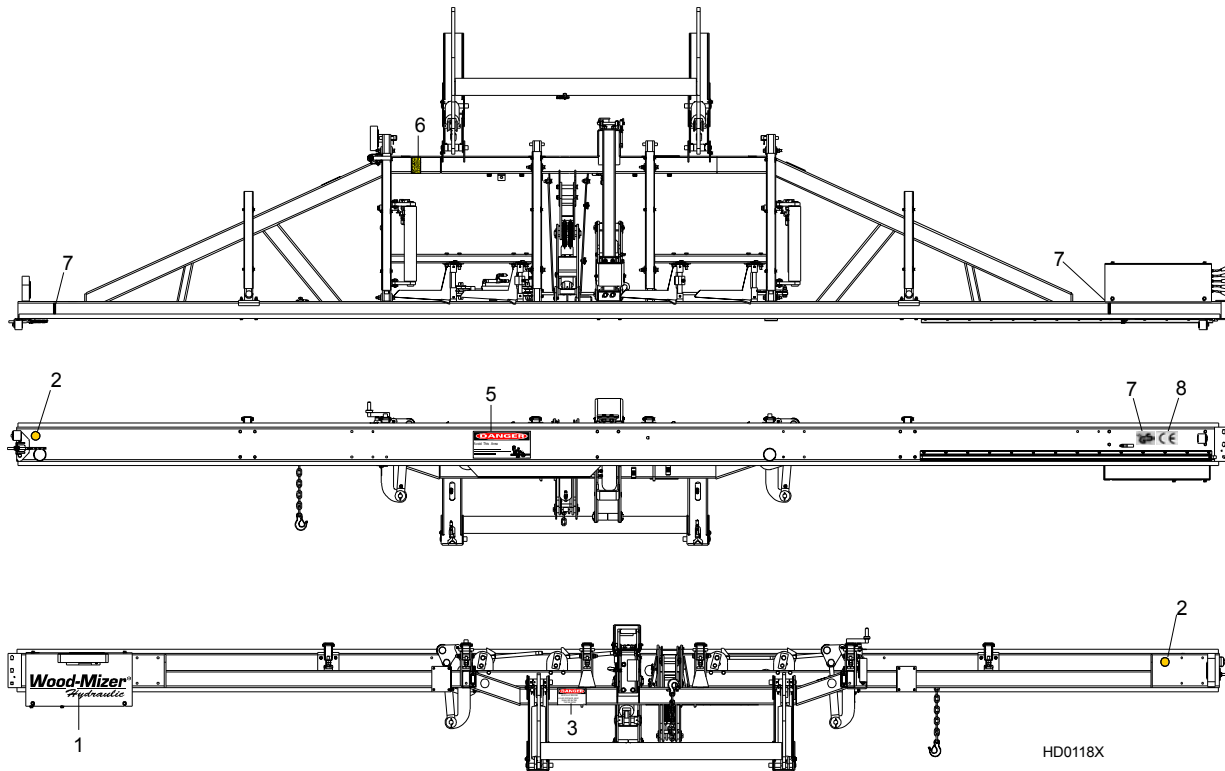

REF	DESCRIPTION (◆ Indicates Parts Available In Assemblies Only)	PART #	QTY.
6	DECAL, AMBER REFLECTIVE 2" ROUND	P07453	2
7	DECAL, KEEP AWAY DANGER	S09851	1
8	DECAL, PINCH POINT DANGER	P10287	1
9	DECAL, SAW HEAD REST CAUTION	S12581	1
10	DECAL, LOG LIMIT STRIPE	S12051	2
11	DECAL, GS SAFETY CERTIFICATION, SMALL	P85072	1
12	DECAL, CE CERTIFIED SAWMILL, SMALL	P85070	1

## SECTION 9 LOG CLAMP, TURNER, LOADER & TOE BOARDS

### 9.1 Manual Log Clamp

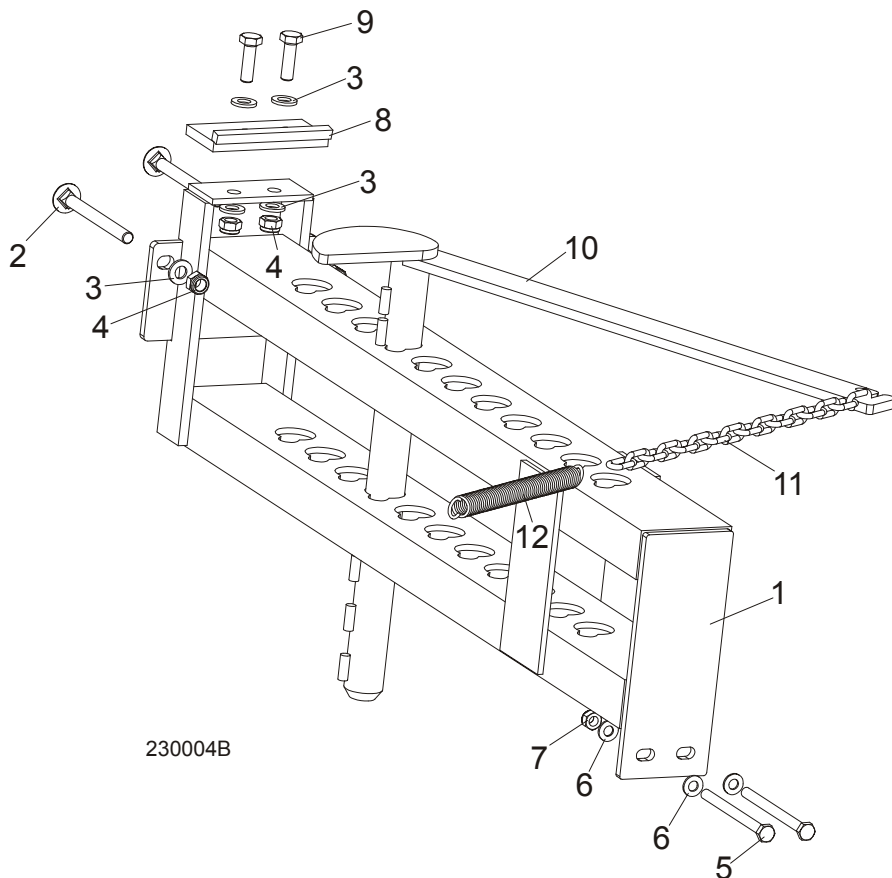

REF	DESCRIPTION (◆ Indicates Parts Available In Assemblies Only)	PART #	QTY.
	MANUAL LOG CLAMP	092683	1
1	Bracket, Log Clamp	092677-1	1
2	Šruba zamk. M12x130-8.8-Fe/Zn5 PN-M/82406	F81004-26	2
3	Washer, 13 Flat	F81056-1	6
4	Nut, M12-8 Hex Nylon Lock	F81034-2	4
5	Šruba M10x125-8.8 Fe/Zn5 PN-M/82101	F81003-18	2
6	Washer, Flat, M10, Zinc	F81055-1	4
7	Nut, M10, Nylon Hex Zinc Lock	F81033-1	2
8	Plate, Log Clamp Stop	086980-1	1
9	Bolt, M12 x 40-8.8 Hex Head	F81004-4	2
10	Clamp, Log	W09412	1
11	Chain, Log Clamp	M04311	1
12	Spring, FI 2,8 X FI 22,2 X 183	091864	1

## 9.2 Log Clamp Assembly

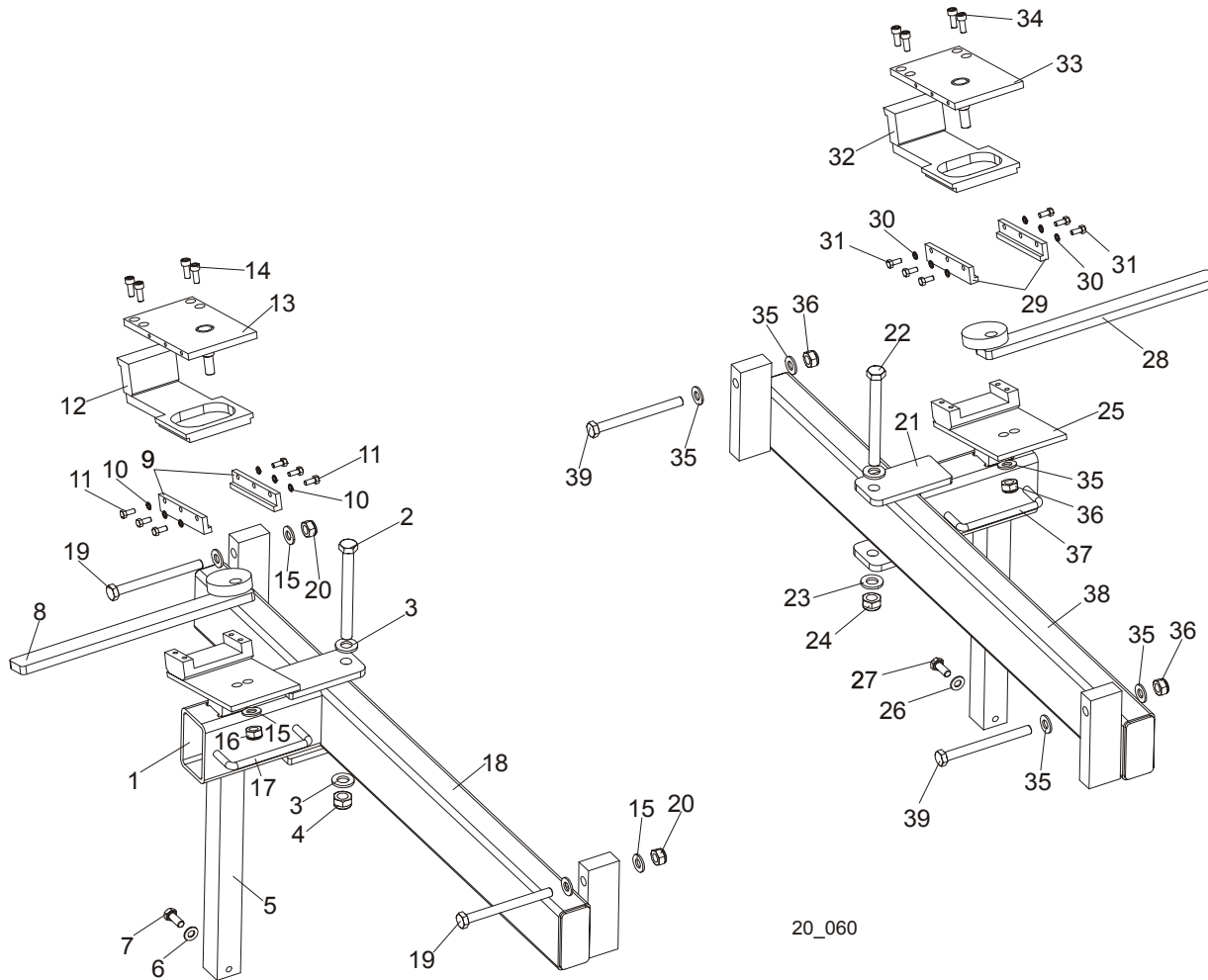

REF	DESCRIPTION (◆ Indicates Parts Available In Assemblies Only)	PART #	QTY.
	<b>LOG CLAMP ASSEMBLY, LEFT (NON-HYDRAULIC)</b>	089631 <sup>1</sup>	1
1	Arm Weldment, Log Clamp Zinc-plated	089624-1	1
2	Bolt, M12x120 8.8 Hex Head Zinc	F81004-38	1
3	Washer, 13 Zinc Flat	F81056-1	2
4	Nut, M12-8 Hex Nylon Zinc Lock	F81034-2	1
5	Mount Weldment, Log Clamp Zinc-plated	090174-1	1
6	Washer, 8.4 Zinc Flat	F81054-1	4
7	Bolt, M8x20-8.8-B Hex Head Full Thread Zinc	F81002-4	2
8	Lever, Log Clamp Zinc-plated	089611-1	1
9	Plate, Log Clamp Side Zinc-plated	089615-1	2
10	Washer, 5.1 Split Lock Zinc	F81052-2	6
11	Bolt, M5x12-5.8 Hex Head Full Thread Zinc	F81000-5	6

# 9 Log Clamp, Turner, Loader & Toe Boards

## Log Clamp Assembly

12	Plate, Clamping Zinc-plated	090202-1	1	
13	Plate, Log Clamp Upper Zinc-plated	089614-1	1	
14	Screw, M6x16-8.8 Hex Socket Set Cap Zinc	F81001-21	4	
15	Washer, 10.5 Zinc Flat	F81055-1	5	
16	Nut, M8-8-B Hex Nylon Zinc Lock	F81032-2	1	
17	Handle, 4" w/Bolts	P08065	1	
18	Bar Weldment, Log Clamp Guide Ptd	089628-1	1	
19	Bolt, M10x110 8.8 Hex Head Zinc	F81003-43	2	
20	Nut, M10-8-B Hex Nylon Zinc Lock	F81033-1	2	
	<b>LOG CLAMP ASSEMBLY, RIGHT (NON-HYDRAULIC)</b>	090349	1	
21	Arm Weldment, Log Clamp Zinc-plated	089624-1	1	
22	Bolt, M12x120 8.8 Hex Head Zinc	F81004-38	1	
23	Washer, 13 Zinc Flat	F81056-1	2	
24	Nut, M12-8 Hex Nylon Zinc Lock	F81034-2	1	
25	Mount Weldment, Log Clamp Zinc-plated	090174-1	1	
26	Washer, 8.4 Zinc Flat	F81054-1	2	
27	Bolt, M8x20-8.8-B Hex Head Full Thread Zinc	F81002-4	2	
28	Lever, Log Clamp Zinc-plated	090348-1	1	
29	Plate, Log Clamp Side Zinc-plated	089615-1	2	
30	Washer, 5.1 Split Lock Zinc	F81052-2	6	
31	Bolt, M5x12-5.8 Hex Head Full Thread Zinc	F81000-5	6	
32	Plate, Clamping Zinc-plated	090202-1	1	
33	Plate, Log Clamp Upper Zinc-plated	090347-1	1	
34	Screw, M6x16-8.8 Hex Socket Head Cap Zinc	F81001-21	4	
35	Washer, 10.5 Zinc Flat	F81055-1	5	
36	Nut, M10-8-B Hex Nylon Zinc Lock	F81033-1	3	
37	Handle, 4" w/Bolts	P08065	1	
38	Bar Weldment, Log Clamp Guide Ptd	089628-1	1	
39	Bolt, M10x110 8.8 Hex Head Zinc	F81003-43	2	

<sup>1</sup> The number of clamps depends on the frame length.



### 9.3 Manual Log Turner

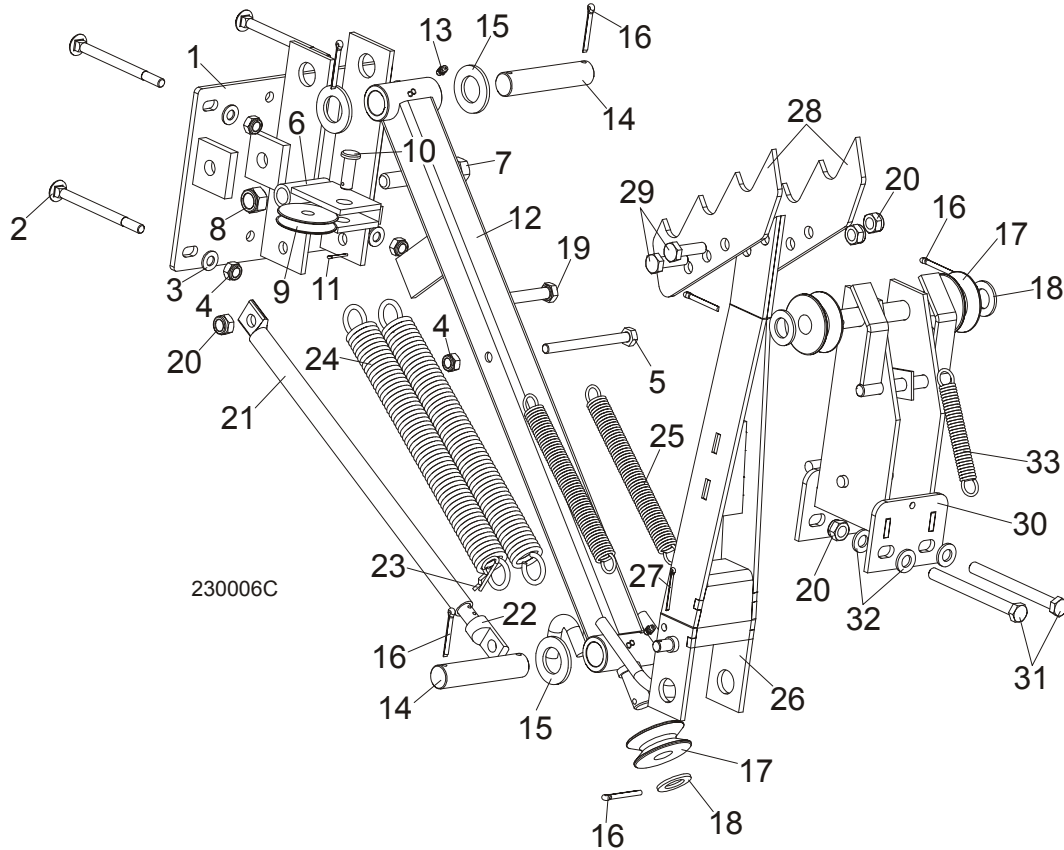

REF	DESCRIPTION (◆ Indicates Parts Available In Assemblies Only)	PART #	QTY.
	<b>MANUAL LOG TURNER OPTION (S/M TYPE FRAME)</b>	091291	1
	<b>MANUAL LOG TURNER OPTION (L TYPE FRAME)</b>	091562	1
1	Uchwyt obracaka ręcznego kłody (Rama typu S/M)	091269-1	1
	Uchwyt obracaka ręcznego kłody (Rama typu L)	090271-1	1
2	Bolt, M10X120mm, Hex Head, Full Thrd, Zinc	F81003-33	4
3	Washer, Flat, M10, Zinc	F81055-1	4
4	Nut, M10, Nylon Hex Zinc Lock	F81033-1	5
5	Bolt, M10x115mm, Hex Head, Gr 5.8 Zinc	F81003-19	1
6	Uchwyt koła linki	091295-1	1
7	Bolt, M16X100mm, Hex Head Full Thrd, Zinc	F81006-2	1
8	Nut, M16, Hex, Nylon Zinc Lock	F81036-2	1
9	Pulley, Manual Turner Arm Cable	091273-1	1
10	Sworzeń 12x35 PN-90/M-83002 Fe/Zn5 ODM.B	F81049-1	1
11	Pin, 2,5x20 Cotter	F81043-1	1
12	Arm, Lower Manual Turner	091256-1	1
13	Fitting, M6 Grease	086280	2

## 9 Log Clamp, Turner, Loader & Toe Boards

### Manual Log Turner

14	Pin, Manual Turner Arm Pivot	091275-1	2	
15	Washer 28 Fe/Zn5	F81061-1	4	
16	Pin, 5x40 Cotter	F81043-31	7	
17	Pulley, Manual Turner Cable	091280-1	3	
18	Washer, M20, Flat Unplated	F81059-1	5	
19	Bolt, M12X120mm, HH, Grade 5.8, Zinc	F81004-38	1	
20	Nut, M12, Hexagon, Nylon, Zinc, Lock	F81034-2	5	
21	Tube, Manual Turner Stop	091537-1	1	
22	Rod, Manual Turner Stop	091540-1	1	
23	Pin, 1/8x1 13/16 Safety	P05059	1	
24	Spring, FI 4,5X FI 35X303	091863	2	◆
25	Spring, FI 2,8 X FI 22,2 X 183	091864	2	
26	Arm, Upper Manual Turner	091263-1	1	
27	Pin, 4x25 Cotter	F81043-2	1	
28	Claw, Log Turner	088082-1	2	
29	Bolt, M12X40mm, Hex Head, Gr 8.8 Zinc	F81004-4	2	
30	Bracket, Manual Turner Cable Pulley	091281-1	1	
31	Bolt, M12x130-8.8-Fe/Zn5 PN-M/82101	F81004-36	2	
32	Washer, M12 , Flat, Zinc	F81056-1	4	
33	Spring, FI 1,9 X FI 14,2 X 104	091865	1	

9.4 Manual Toe Board

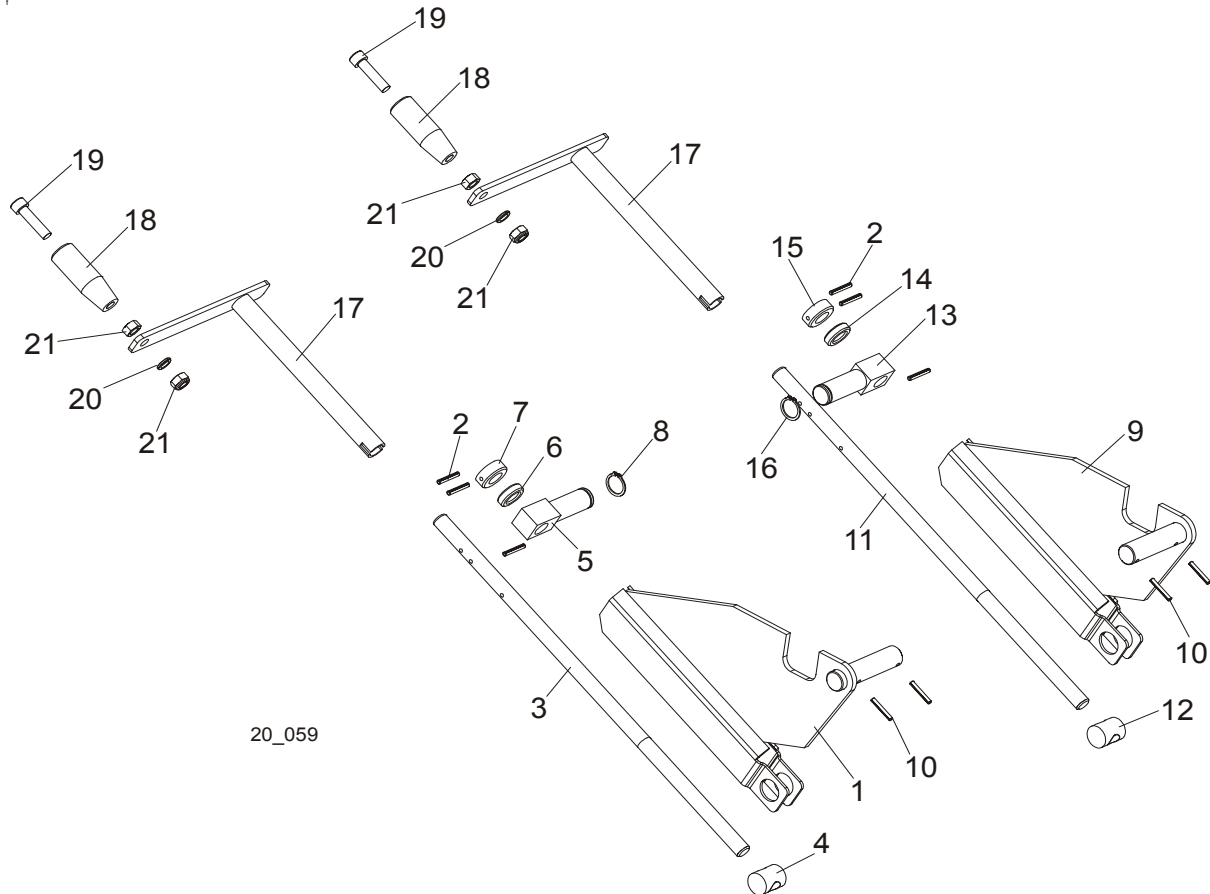

20\_059

REF	DESCRIPTION (◆ Indicates Parts Available In Assemblies Only)	PART #	QTY.
	<b>TOE BOARD KIT, MANUAL FRONT</b>	090026	1
1	Plate Weldment, Manual Toe Board Front	090025-1	1
2	Pin, Zinc Roll PN-EN ISO 8752-5X35-N-C	F81044-9	3
3	Shaft, Manual Toe Board	090344-1	1
4	Nut, Special Threaded	090017	1
5	Pivot, Manual Toe Board Shaft	090013-1	1
6	Bearing, 5/8" Thrust	P04214	1
7	Collar, 16	F81039-6	1
8	<b>Ring, Z 22 Outside Retaining</b>	F81090-24	1
10	Pin, 4x30 Zinc Roll	F81044-7	2
	<b>TOE BOARD KIT, MANUAL REAR</b>	090024 <sup>1</sup>	1
2	Pin, 4x30 Zinc Roll PN-EN ISO 8752-5X35-N-C	F81044-9	3
9	Plate Weldment, Manual Toe Board Rear	090023-1	1
10	Pin, 4x30 Zinc Roll	F81044-7	2
11	Shaft, Manual Toe Board	090016-1	1

# 9 Log Clamp, Turner, Loader & Toe Boards

## Manual Toe Board

---

12	Nut, Special Threaded	090017	1	
13	Pivot, Manual Toe Board Shaft	090013-1	1	
14	Bearing, 5/8" Thrust	P04214	1	
15	Collar, 16	F81039-6	1	
16	<b>Ring, Z 22 Outside Retaining</b>	F81090-24	1	
	<b>Crank Assembly, Manual Toe Board</b>	A09432	2	
17	Crank, Manual Toe Board	W09431	1	
18	Handle, Crank	S08291-W	1	
19	Screw, 3/8-16 x 2 1/2" Socket Head Cap	F05007-24	1	
20	Washer, 3/8" Split Lock	F81055-2	1	
21	Nut, 3/8-16 Hex	F05010-1	2	

<sup>1</sup> The number of kits depends on the frame length.

## 9.5 Log Loading Ramps

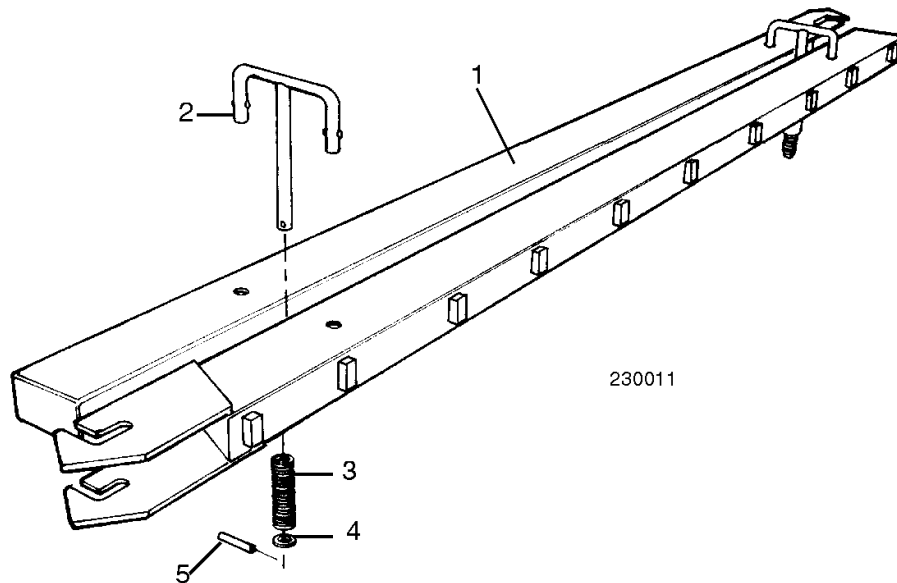

REF	DESCRIPTION (◆ Indicates Parts Available In Assemblies Only)	PART #	QTY.	
	<b>RAMP KIT, LOG LOADING WITH RETAINERS</b>	K09466	1	
1	Ramp, Log Loading	W09014	2	
	Retainer Kit, Log Ramp	K09810	2	
2	Retainer, Log Ramp	W09413	1	◆
3	Spring, Log Ram Retainer	P09335	1	
4	Washer, 5/8" I.D. x .100" Thick Nylon	F05011-19	1	
5	Pin, 3/16" x 1" Roll	F05012-11	1	