

Wood-Mizer®

Parts Manual

LT70S AC MH
LT70M AC MH

rev. B5.00
rev. B5.00



Safety is our #1 concern! Read and understand all safety information and instructions before operating, setting up or maintaining this machine.

May 2002

Form #1050

Table of Contents

Section-Page

SECTION 1	GENERAL INFORMATION	1-1
1.1	How To Use The Parts List	1-1
1.2	Sample Assembly	1-1
SECTION 2	BLADE GUIDE ROLLERS & ARM	2-1
2.1	Blade Guide Assembly, Idle Side	2-1
2.2	Blade Guide Assembly, Drive Side	2-2
2.3	Blade Guide Arm Drive Assembly.....	2-4
2.4	Blade Guide Mount Assembly, Drive Side	2-6
SECTION 3	BLADE WHEELS & TENSIONER	3-1
3.1	Blade Drive Assembly.....	3-1
3.2	Idle Blade Wheel Assembly	3-2
3.3	Hydraulic Blade Tensioner Assembly.....	3-3
3.4	Sawdust Flow Guide.....	3-5
SECTION 4	SAW HEAD	4-1
4.1	Middle Throat Screw	4-1
4.2	Drive Belt Tensioner	4-1
4.3	Board Return Assembly (optional).....	4-2
4.4	Water Lube Assembly	4-4
4.5	LT70AC Saw Head Decals	4-5
4.6	Blade Housing Covers.....	4-7
4.7	Sawdust Chute	4-8
SECTION 5	CONTROL BOXES	5-1
5.1	Control Assembly, LT70 AH	5-1
5.2	Drum Switches	5-2
5.3	Circuit Breakers.....	5-3
5.4	Front Panel Assembly & Harnesses	5-4
5.5	Solenoids	5-5
SECTION 6	UP/DOWN SYSTEM	6-1
6.1	Up/Down Rollers & Covers	6-1
6.2	Blade Height Scale	6-2
6.3	Up/Down Chain & Sprockets.....	6-3
6.4	Up/Down Drive Assembly	6-4
SECTION 7	FEED SYSTEM & TRACK ROLLERS	7-1
7.1	Upper Track Rollers And Wipers.....	7-1
7.2	Power Feed Assembly	7-3
7.3	Feed Chain/Stop, LT70 S/M	7-4

Table of Contents

Section-Page

7.4	Lower Track Rollers.....	7-5	
SECTION 8	BED FRAME ASSEMBLY		8-1
8.1	Bed Rail Assembly, Rear	8-1	
8.2	Bed Rail Assembly, Front Middle	8-2	
8.3	Bed Rail Assembly, Rear Middle	8-3	
8.4	Clamp Mount Assembly, Front (A/DH5/7).....	8-4	
8.5	Clamp Mount Assembly, Rear (A/DH5/7).....	8-5	
8.6	Leg, Stationary	8-7	
8.7	Pivot Bed Rail Assembly.....	8-9	
8.8	Log Side Support Assembly (Manual)	8-10	
8.9	LT70 S/M Saw Head Rest Pin Assembly.....	8-11	
8.10	Bed Frame Decals	8-12	
8.11	Tie Down Chain Assembly	8-13	
SECTION 9	LOG CLAMP, TURNER, LOADER & TOE BOARDS		9-1
9.1	Manual Log Clamp	9-1	
9.2	Log Clamp Assembly	9-2	
9.3	Manual Log Turner.....	9-3	
9.4	Manual Toe Board.....	9-5	
9.5	Manual Log Loader (S/M type frame)	9-6	
9.6	Manual Log Loader Pump.....	9-7	

SECTION 1 GENERAL INFORMATION

1.1 How To Use The Parts List

- Use the index above to locate the assembly that contains the part you need.
- Go to the appropriate section and locate the part in the illustration.
- Use the number pointing to the part to locate the correct part number and description in the table.
- Parts shown indented under another part are included with that part.
- Parts marked with a diamond (◆) are only available in the assembly listed above the part.

See the sample table below. Sample Part #A01111 includes part F02222-2 and subassembly A03333. Subassembly A03333 includes part S04444-4 and subassembly K05555. The diamond (◆) indicates that S04444-4 is not available except in subassembly A03333. Subassembly K05555 includes parts M06666 and F07777-77. The diamond (◆) indicates M06666 is not available except in subassembly K05555.

1.2 Sample Assembly				
REF	DESCRIPTION (◆ Indicates Parts Available In Assemblies Only)	PART #	QTY.	
	Sample Assembly, Complete (Includes All Indented Parts Below)	A01111	1	
1	Sample Part	F02222-22	1	
	Sample Subassembly (Includes All Indented Parts Below)	A03333	1	
2	Sample Part (◆ Indicates Part Is Only Available With A03333)	S04444-4	1	◆
	Sample Subassembly (Includes All Indented Parts Below)	K05555	1	
3	Sample Part (◆ Indicates Part Is Only Available With K05555)	M06666	2	◆
4	Sample Part	F07777-77	1	

To Order Parts:

- From Europe call our European Headquarters and Manufacturing Facility in Kolo, Poland at **+48-63-2626000**. From the continental U.S., call our toll-free Parts hotline at **1-800-448-7881**. Have your customer number, vehicle identification number, and part numbers ready when you call.
- From other international locations, contact the Wood-Mizer distributor in your area for parts.

SECTION 2 BLADE GUIDE ROLLERS & ARM

2.1 Blade Guide Assembly, Idle Side

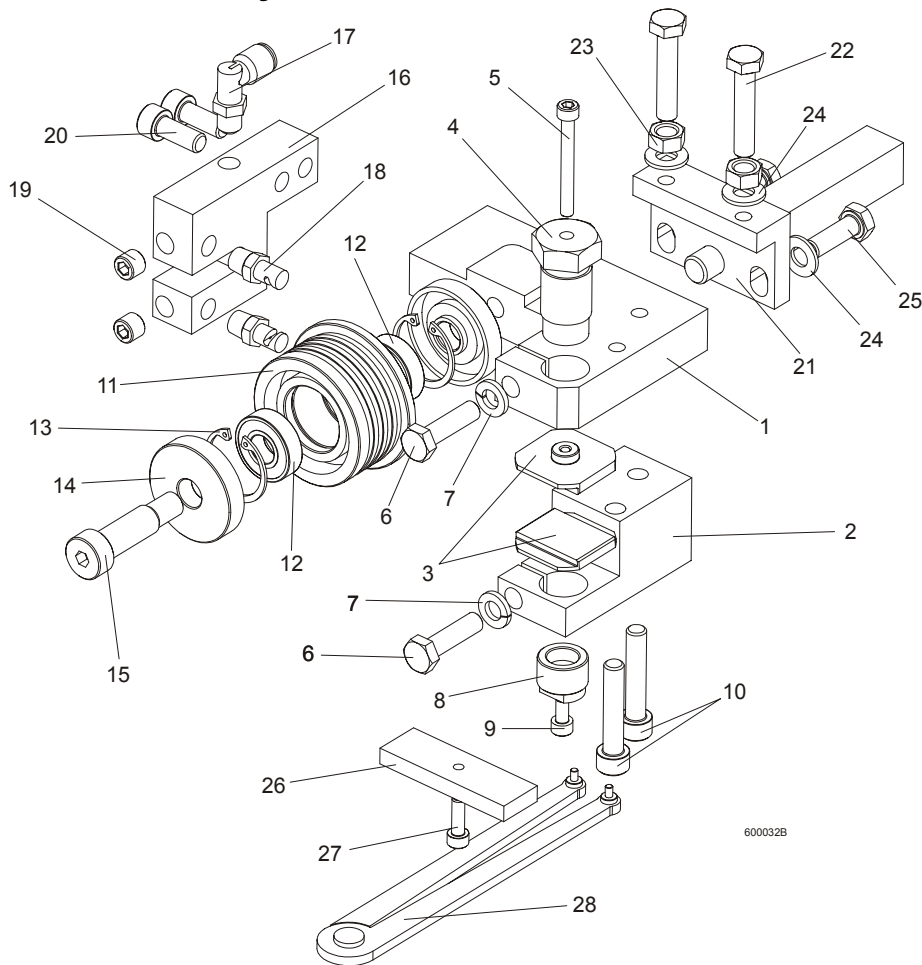

REF	DESCRIPTION (u Indicates Parts Available In Assemblies Only)	PART#	QTY.
	BLADE GUIDE ASSEMBLY, IDLE SIDE	090943	1
	BLADE GUIDE ASSEMBLY, IDLE SIDE, EXTENDED (for optional use with 1 1/2" blades)	092997	1
1	Block, Blade Guide Mount Zinc-plated	090947-1	1
2	Block, Lower Ceramic Pad Mount Zinc-plated	090948-1	1
3	Block, Blade Guide Zinc	093430-1	2
4	Bolt, Upper Pad Adjustment Zinc-plated	089515-1	1
5	Screw, M5x45 DIN912 A2-70 Hex Socket Head Cap Stainless Steel	F81000-24	1
6	Bolt, M8x30 DIN933 A2-70 Stainless Steel	F81002-27	2
7	Washer, 8.2 Split Lock Zinc	F81054-4	2
8	Screw, Lower Pad Adjuster Zinc-plated	090945-1	1
9	Screw, M5x10 DIN912 A2-70 Hex Socket Head Cap Stainless Steel	F81000-23	1
10	Screw, M8x40-8.8 Hex Socket Head Cap Zinc	F81002-29	2
	Roller, Blade Guide Narrow W/Bearing	088261	1
	Roller, Blade Guide W/Bearing, Extended	092939	1
11	Roller, Blade Guide Narrow	087889	1
12	Bearing, 6001 2RSR NACHI	087893	2
13	Ring, W28 Inside Retaining	F81090-9	2

14	Washer, Blade Guide Roller Spacer Zinc-plated	087891-1	2	
15	Screw, 12/M10x30 12.9 ISO 7379 Socket Head Shoulder	F81003-70	1	
	Screw, 12/M10x35 12.9 ISO 7379 Socket Head Shoulder, (used with the Extended Roller only)	F81003-48	1	
16	Block, Nozzle Mounting Zinc-plated	090487-1	1	
17	Fitting, 90° Elbow 1/8NPT-1/4 Tube Swivel	P09736	1	
18	Nozzle, Blade Lube Spray	033479	2	
19	Plug, M10x1 DIN 906 BN40 "BOSSARD"	F81015-3	2	
20	Screw, M8x20-8.8 Hex Socket Head Cap Zinc	F81002-30	2	
21	Pivot Weldment, Blade Guide Zinc-plated	089509-1	1	
22	Bolt, M8x40 DIN933 A2-70 Stainless Steel	F81002-28	2	
23	Nut, M8 DIN934 A2-70 Stainless Steel	F81032-7	2	
24	Washer, 8.4 Zinc Flat	F81054-1	4	
25	Bolt, M8x25 DIN933 A2-70 Stainless Steel	F81002-26	2	
	Block, Blade Guide Alignment	090951	1	
26	Block, Blade Guide Alignment Zinc-plated	090805-1	1	
27	Screw, M5x16-8.8 Hex Socket Head Cap Zinc	F81000-25	1	
28	Tool, 62860-3 (PERSCHMAN) Lower Pad Adjustment	090949	1	

2.2 Blade Guide Assembly, Drive Side

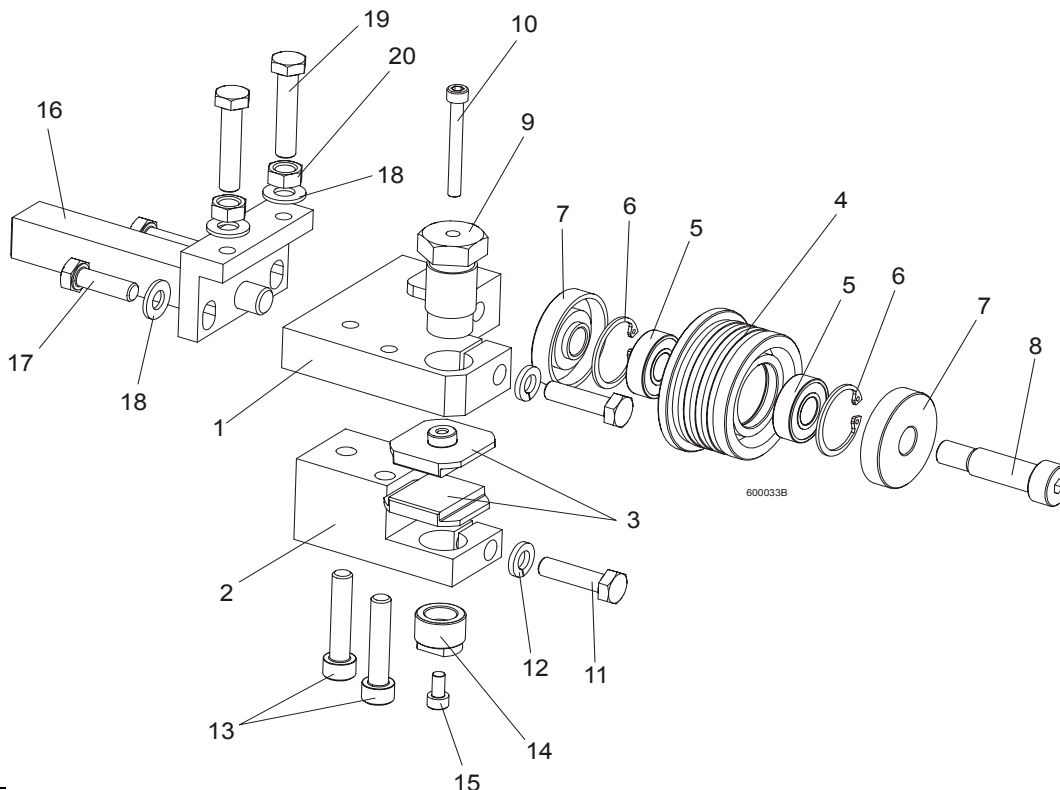

REF	DESCRIPTION (u Indicates Parts Available In Assemblies Only)	PART #	QTY.
	BLADE GUIDE ASSEMBLY, DRIVE SIDE	090942	1
	BLADE GUIDE ASSEMBLY, DRIVE SIDE, EXTENDED (for optional use with 1 1/2" blades)	092998	1
1	Block, Blade Guide Mount Zinc-plated	090944-1	1
2	Block, Lower Ceramic Pad Mount Zinc-plated	090946-1	1
3	Block, Blade Guide Zinc	093430-1	2

	Roller, Blade Guide Narrow W/Bearing	088261	1	
	Roller, Blade Guide W/Bearing, Extended	092939	1	
4	Roller, Blade Guide Narrow	087889	1	
5	Bearing, 6001 2RSR NACHI	087893	2	◆
6	Ring, W28 Inside Retaining	F81090-9	2	
7	Washer, Blade Guide Roller Spacer Zinc-plated	087891	2	
8	Screw, 12/M10x30 12.9 ISO 7379 Socket Head Shoulder	F81003-70	1	
	Screw, 12/M10x35 12.9 ISO 7379 Socket Head Shoulder (used with the Extended Roller only)	F81003-48	1	
9	Bolt, Upper Pad Adjustment	089515	1	
10	Screw, M5x45 DIN912 A2-70 Hex Socket Head Cap Stainless Steel	F81000-24	1	
11	Bolt, M8x30 DIN933 A2-70 Stainless Steel	F81002-27	2	
12	Washer, 8.2 Split Lock Zinc	F81054-4	2	
13	Screw, M8x40-8.8 Hex Socket Head Cap Zinc	F81002-29	2	
14	Screw, Lower Pad Adjustment Zinc-plated	090945-1	1	
15	Screw, M5x10 DIN912 A2-70 Hex Socket Head Cap Stainless Steel	F81000-23	1	
16	Pivot Weldment, Blade Guide Zinc-plated	089509-1	1	
17	Bolt, M8x25 DIN933 A2-70 Stainless Steel	F81002-26	2	
18	Washer, 8.4 Zinc Flat	F81054-1	4	
19	Bolt, M8x40 DIN933 A2-70 Stainless Steel	F81002-28	2	
20	Nut, M8 DIN934 A2-70 Stainless Steel	F81032-7	2	

2.3 Blade Guide Arm Drive Assembly

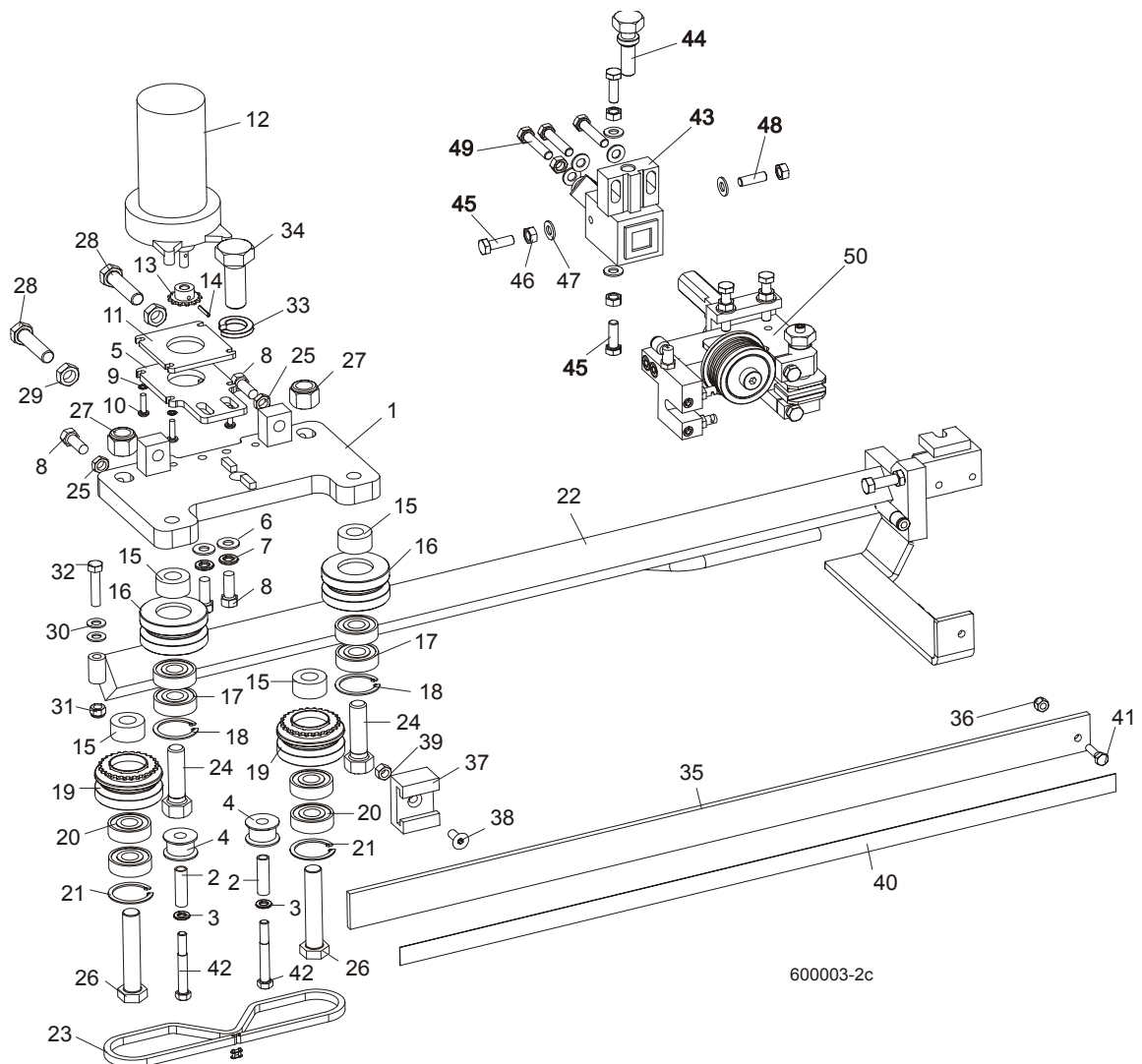

REF	DESCRIPTION (u Indicates Parts Available In Assemblies Only)	PART#	QTY.
	BLADE GUIDE ARM ASSEMBLY	090950	1
1	Plate Weldment, Blade Guide Arm Zinc-plated	090800-1	1
2	Bushing, 0.322 x 0.44 x 1 1/2" Spacer	S09996	2
3	Washer, 5/16" Split Lock Zinc	F05011-13	2
4	Roller, Chain Guide	090801	2
5	Plate, Blade Guide Motor Mount Ptd	090803-1	1
6	Washer, 10.5 Zinc Flat	F81055-1	2
7	Washer, 3/8" Zinc Flat	F05011-4	2
8	Bolt, M10 x 25 8.8 Hex Head Full Thread	F81003-31	4
9	Washer, 5.3 Zinc Flat	F81052-1	4
10	Screw, #10-32 x 3/4 CrS1 Phillips Head	F05004-38	4
11	Plate, Spacer Ptd	090802-1	1
12	Motor, 53:1 Gear ASA Blade Guide Arm	P09698-1	1
13	Sprocket, 25B13 x .3130	P09970	1
14	Pin, 3 x 14 Zinc Roll	F81044-4	1
15	Spacer, Drive Roller Zinc-plated	090804-1	4

	ROLLER ASSEMBLY, BLADE GUIDE ARM IDLER	042543	2	
16	Housing, 2 1/2" V-Groove	042536	1	
17	Bearing, 6203 2RSP6-5/8 CX	095087	2	
18	Ring, 1.575" ID 5002-156 Retaining	F04254-8	1	
	ROLLER ASSEMBLY, BLADE GUIDE ARM DRIVE	042542	2	
19	Housing, 2 1/2" V-Groove W/Sprocket	042541	1	
20	Bearing, 6203 2RSP6-5/8 CX	095087	2	
21	Ring, 1.575" ID 5002-156 Retaining	F04254-8	1	
22	Arm Weldment, Blade Guide Zinc-plated	090479-1	1	
23	Chain, #25 x 92 PITCHES B/G	093805	1	
24	Bolt, 5/8-18 x 2 1/4 Hex Head Grade 5	F05009-80	2	
25	Nut, M10-04-W Zinc Hex Thin	F81033-6	2	
26	Bolt, 5/8-18 x 3 1/4 Hex Head Grade 5	F05009-80	2	
27	Nut, 5/8-18 Hex Nylon Lock	F05010-71	2	
28	Screw, M12 x 1.25 x 60-33H Zinc Hex Set W/Full Dog Point	F81004-52	2	
29	Nut, M12 x 1.25 8.8 Zinc Hex Thin	F81034-5	2	
30	Washer, 8.4 Zinc Flat	F81054-1	1	
31	Nut, M8-8-B Hex Nylon Zinc Lock	F81032-2	1	
32	Bolt, M8 x 40-8.8 Hex Head Full Thread Zinc	F81002-15	1	
33	Washer, DIN 6319-21C Spherical	F81059-6	1	
34	Bolt, M20 x 1.5 x 50-8.8-B Hex Head Full Thread Zinc	F81007-2	1	
35	Guard, Blade	088306	1	
36	Nut, M6-8-B Hex Nylon Zinc Lock	F81031-2	1	
37	Guide, Blade Guard	088305	1	
38	Screw, M8 x 25 Cross Recessed Countersunk Head Zinc	F81002-51	1	
39	Nut, M8-8-B Hex Nylon Zinc Lock	F81032-2	1	
40	Decal, Warning	015849	1	
41	Bolt, M6 x 20-8.8 Hex Head Full Thread Zinc	F81001-2	2	
42	Screw, 12/M10 x 20 12.9 ISO7379(BOSSARD) Socket Head Shoulder	F81003-68	2	
43	Mounting Block, LT70 Blade Guide, zinc	089503-1	1	
44	Bolt, Blade Guide Adjustment, zinc	089502-1	1	
45	Bolt, M8x25 DIN933 A2-70, Stainless	F81002-26	3	
46	Nut, M8 DIN934 A2-70, Stainless	F81032-7	5	
47	Washer, 8.4 FLAT,ZINC	F81054-1	7	
48	Screw, Set, M8x8-33H FE/ZN Hex Socket Head, Stainless	F81014-3	1	
49	Bolt M8x40 DIN933 A2-70, Stainless	F81002-28	3	
50	Blade Guide Parts (See Section 2.1)	093805	1	

2.4 Blade Guide Mount Assembly, Drive Side

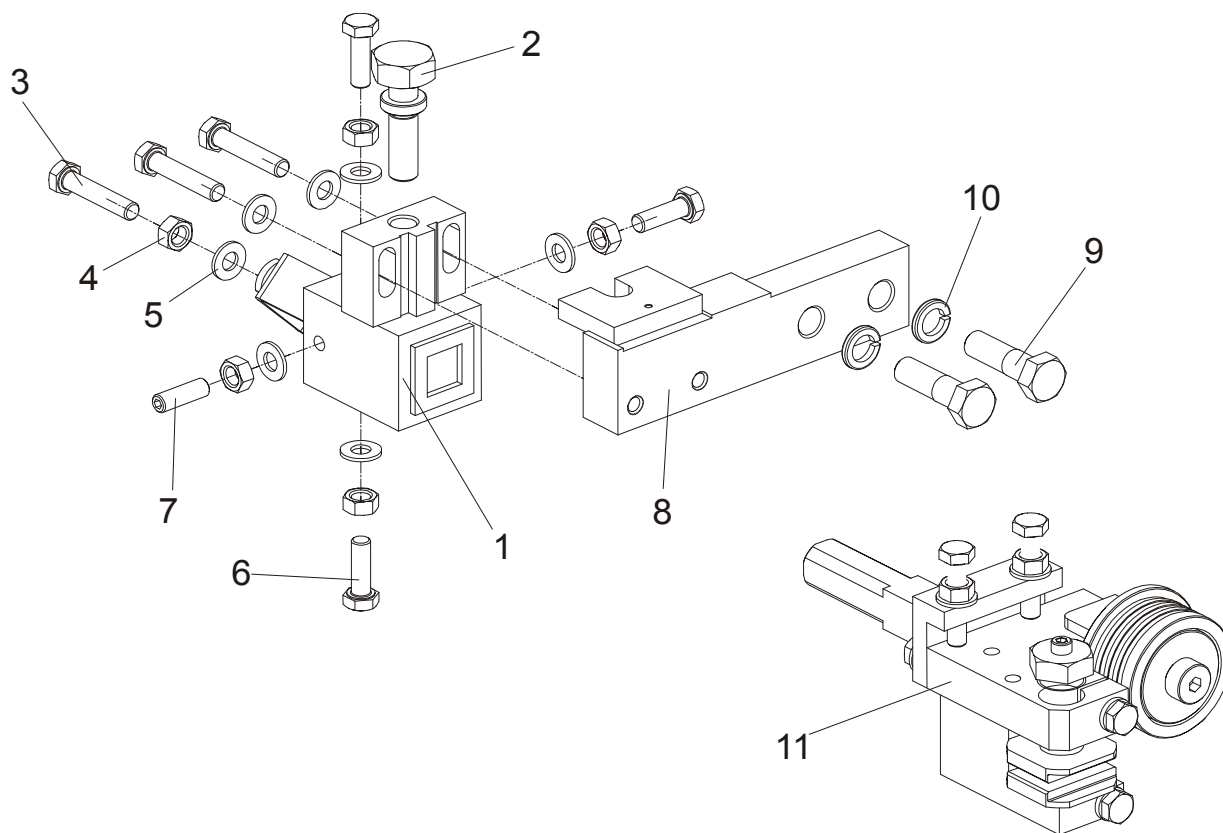

L.P.	OPIS (♦ wskazuje części dostępne jedynie w zespołach)	NUMER KAT.	SZT.	
	MOUNTING BLOCK, DRIVE SIDE	091338	1	
1	MOUNTING BLOCK, BLADE GUIDE, DRIVE SIDE, ZINC	089503-1	1	
2	BOLT, BLADE GUIDE ADJUSTMENT, ZINC	089502-1	1	
3	BOLT, M8X40 DIN933 A2-70, STAINLESS	F81002-28	3	
4	NUT, M8 DIN934 A2-70, STAINLESS	F81032-7	5	
5	WASHER, 8.4 FLAT,ZINC	F81054-1	7	
6	BOLT, M8X25 DIN933 A2-70, STAINLESS	F81002-26	3	
7	SCREW, BLADE GUIDE ADJUSTMENT, M8X25 A2-70 DIN 913, STAINLESS	F81014-3	1	
8	BAR, BLADE GUIDE MOUNT, ZINC	089501-1	1	
9	BOLT,M12X40-8.8 HEX HEAD ZINC	F81004-1	2	
10	WASHER, M12 SPLIT LOCK ZINC	F81056-2	2	
11	BLADE GUIDE, DRIVE SIDE, COMPLETE (LT70) See Section 2.2	090942	1	

SECTION 3 BLADE WHEELS & TENSIONER

3.1 Blade Drive Assembly

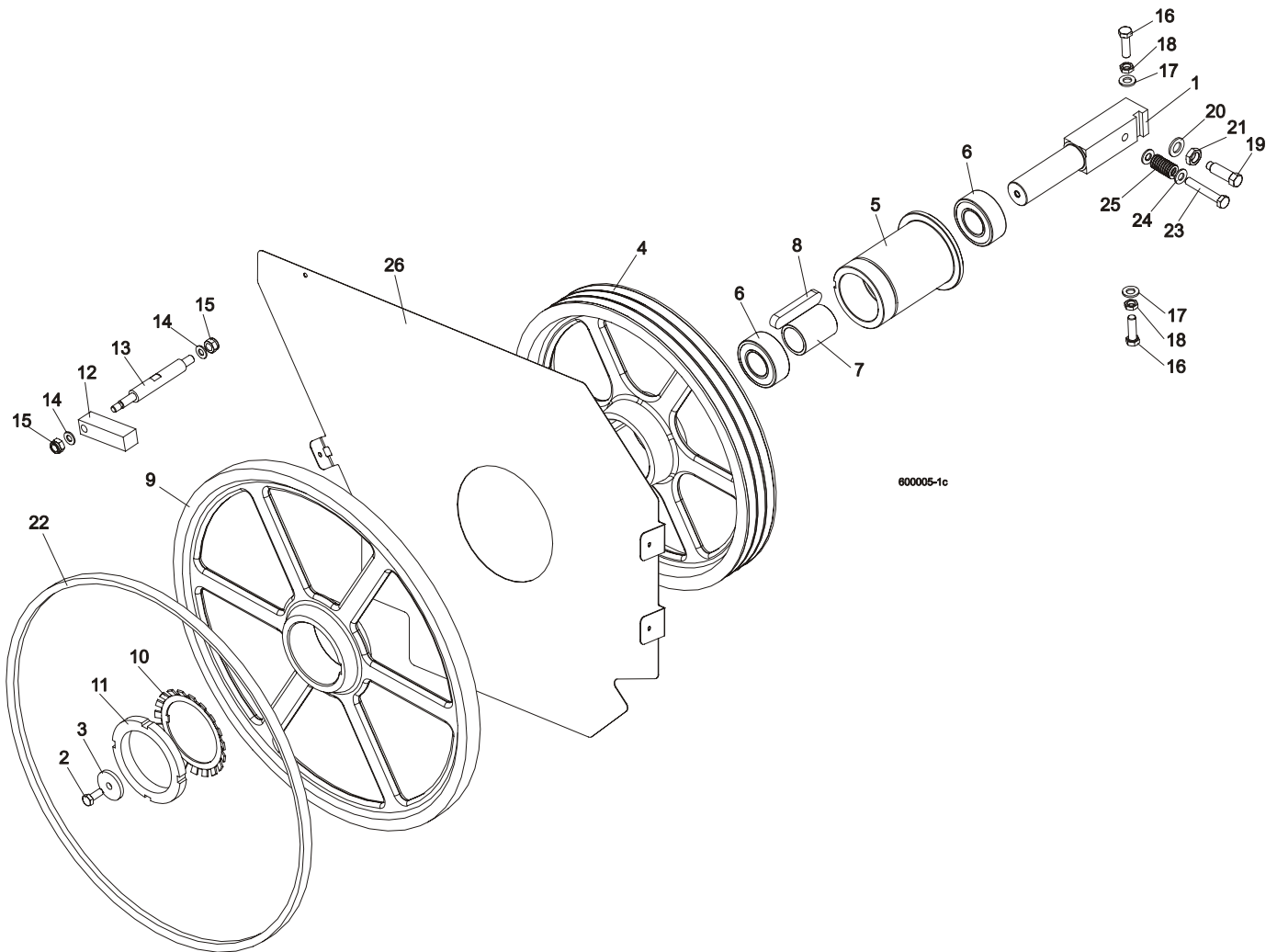

REF	DESCRIPTION (◆ Indicates Parts Available In Assemblies Only)	PART #	QTY.
1	SHAFT, BLADE DRIVE WHEEL	088475	1
2	BOLT, M10x25 8.8 HEX HEAD FULL THREAD	F81003-31	1
3	WASHER, BLADE DRIVE WHEEL	088956-1	1
	PULLEY ASSEMBLY, BLADE DRIVE	088561	1
4	Pulley, 3-Groove 484 mm Diameter	089457-1	1
5	Bushing, Blade Drive Wheel	088476	1
6	Bearing, 3208.2rsr.tvh (FAG) Rolling	088449	2
7	Spacer, Drive Bearing	088478	1
8	Key, A20x12x100 Parallel	088477	1
9	WHEEL, BLADE DRIVE	090811	1
10	WASHER, MB21 (FAG) LOCK	088451	1
11	NUT, KM21(M105X2) (FAG) LOCK	088450	1
12	BAR, WHEEL SCRAPER	088781	1
13	SHAFT, WHEEL SCRAPER	088780-1	1

14	WASHER, 10.5 ZINC FLAT	F81055-1	2	
15	NUT, M12-8 HEX NYLON ZINC LOCK	F81034-2	2	
16	BOLT, M12X1.25X40 HEX HEAD	F81004-42	3	
17	WASHER, 13 FLAT ZINC	F81056-1	3	
18	NUT, M12X1.25 8.8 THIN ZINC	F81034-5	3	
19	SCREW, M16X1.5X50-33H HEX HEAD FULL DOG POINT SET ZINC	F81006-14	1	
20	WASHER, 17 ZINC FLAT	F81058-1	1	
21	NUT, M16x1.5-08-B ZINC THIN	F81036-6	1	
22	BELT, BLADE WHEEL B72.5	017922	1	
23	BOLT M10X65	F81003-67	1	
24	WASHER, 10.5 ZINC FLAT	F81055-1	2	
25	SPRING19X38	034430	1	
26	PLATE, LT70AC SAW HEAD (OPTION)	100897-1	1	
	BELT 3B/HB2462 La	089464	1	

3.2 Idle Blade Wheel Assembly

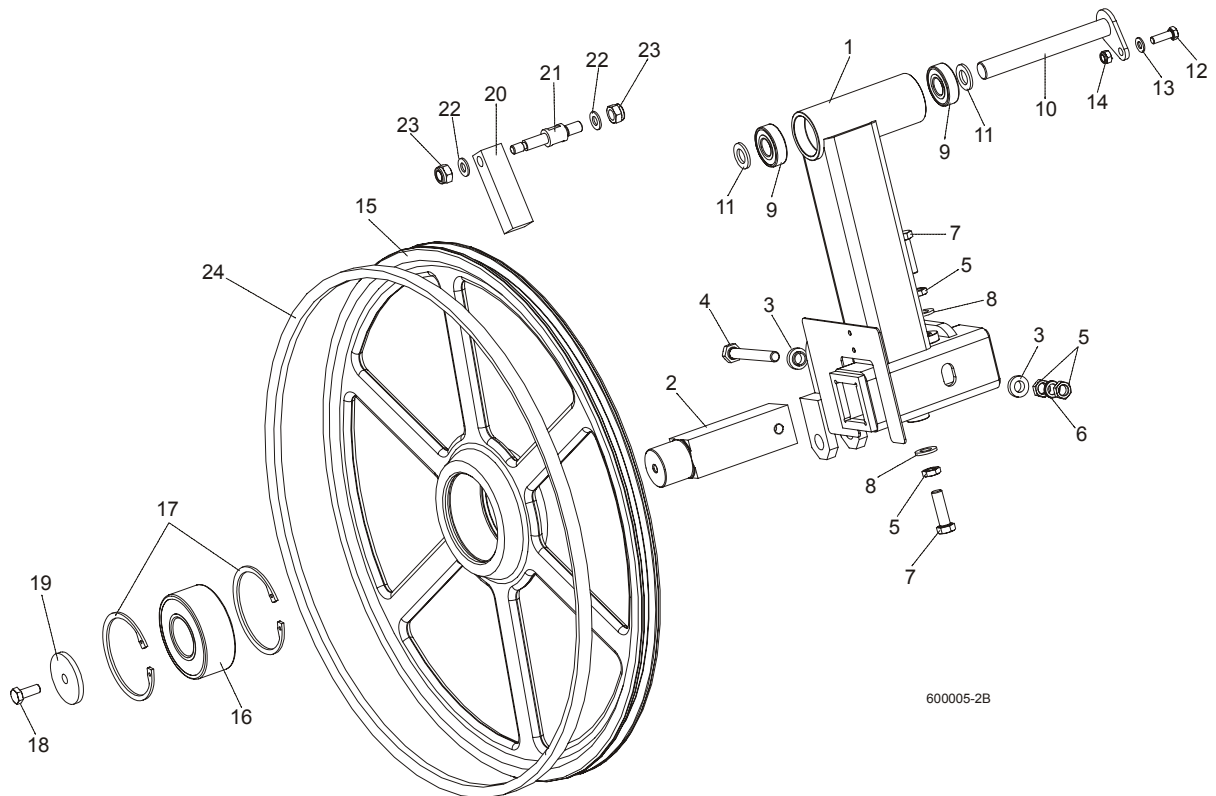

REF	DESCRIPTION (◆ Indicates Parts Available In Assemblies Only)	PART #	QTY.
	TUBE, LT70 IDLE SIDE BLADE WHEEL W/LEVER COMPLETE	092791	1
1	Tube Weldment, LT70 Idle Blade Wheel w/Lever	092780-1	1
2	Shaft, Idle Blade Wheel	088474	1
3	Washer, Zinc Special	086769-1	2
4	Bolt, M12x1.25x100-8.8 Hex Head Zinc	F81004-41	1
5	Nut, M12x1.25 8.8 Hex ZincThin	F81034-5	4
6	Washer, Z12.2 Split Zinc Lock	F81056-2	1
7	Bolt, M12x1.25x40 Hex Head	F81004-42	2
8	Washer, 13 Zinc Flat	F81056-1	2
9	Bearing, 6204 2RS-CX Rolling	088447	2

10	PIN WELDMENT, PIVOT	088759-1	1	
11	WASHER, 17 ZINC FLAT	F81058-1	2	
12	BOLT, M8X25-8.8-B HEX HEAD FULL THREAD ZINC	F81002-5	1	
13	WASHER, 8.4 ZINC FLAT	F81054-1	1	
14	NUT, M8-8-B HEX NYLON ZINC LOCK	F81032-2	1	
	WHEEL ASSEMBLY, IDLE SIDE	088764	1	
15	Wheel, Blade Idle Side	090810	1	
16	Bearing, 3309B.2RSR.TVH-P66 FAG	086428	1	
17	Ring, W100 Spring Retaining	F81090-10	2	
18	BOLT, M10X25 8.8 HEX HEAD FULL THREAD	F81003-31	1	
19	WASHER, IDLE BLADE WHEEL RETAINING	088957-1	1	
20	SCRAPER, IDLE BLADE WHEEL	088781	1	
21	SHAFT, SHORT ZINC WHEEL SCRAPER	088779-1	1	
22	WASHER, 10.5 ZINC FLAT	F81055-1	2	
23	NUT, M12-8 HEX NYLON ZINC LOCK	F81034-2	2	
24	BELT, BLADE WHEEL B72.5	017922	1	

3.3 Hydraulic Blade Tensioner Assembly

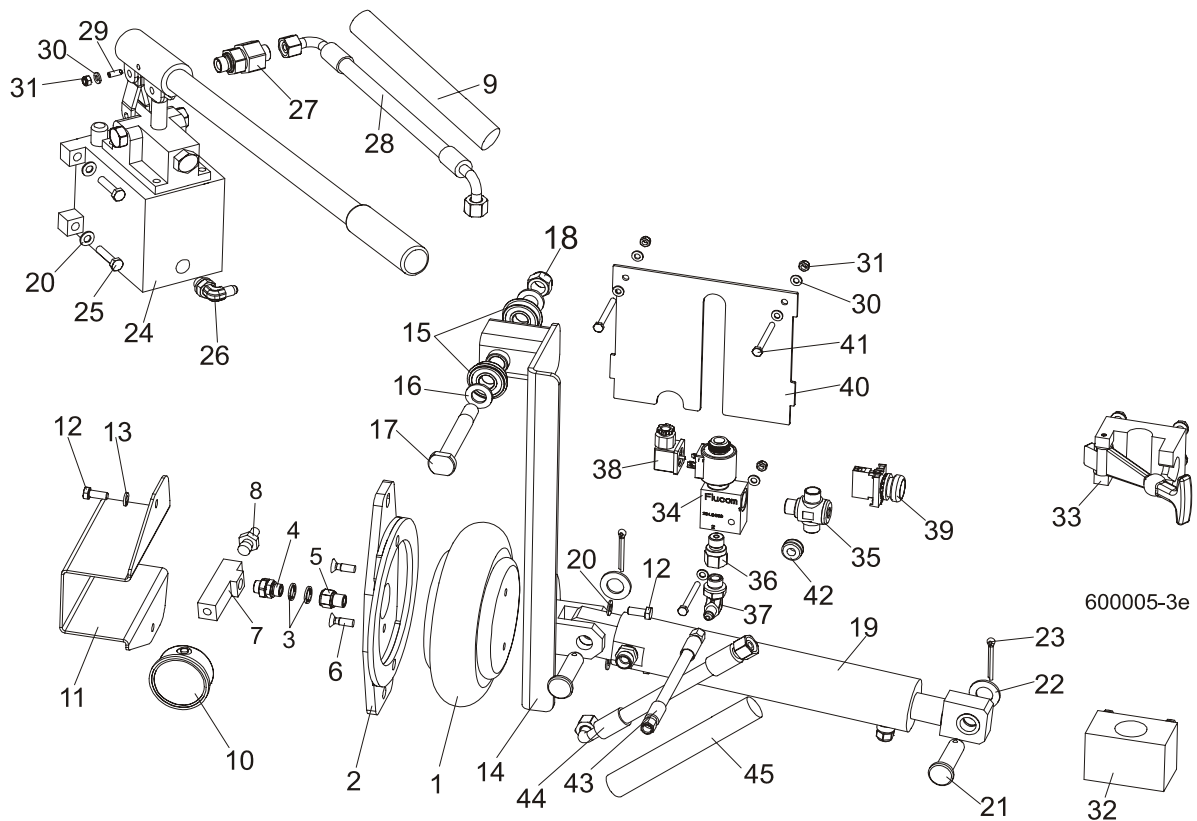

REF	DESCRIPTION (◆ Indicates Parts Available In Assemblies Only)	PART #	QTY.	
	HYDRAULIC BLADE TENSIONER, COMPLETE	092775	1	
1	Bag, POJ 192 308 100 0 Air	088576	1	
2	Bracket, Air Bag Mount	088798-1	1	
3	Seal, G1/4 866-014-000-0	090809	4	
4	Nipple, 1/4 8632141400)BOSCH	097703	1	
5	Fitting, 1/4 Thread/1/4 Thread 2521	097704	1	
6	Bolt, M8x25 Pan Head Zinc	F81002-51	2	

7	Tee Connector, Special	097702-1	1	
8	Fitting, 1/4" Thread 390 004 004 0 (REXROTH) Air Tank Valve	088575	1	
9	Hose Protection	098488	1	
10	Gauge, M63T-2,5/20G G 1/8 0-0,6 MPa/PSI Air Pressure	088568	1	
11	Guard, Air Pressure Gauge	088924-1	1	
12	Screw, M8x25 Cross Recessed Countersunk Head Zinc	F81002-4	4	
13	Washer 8.2 Zinc Split	F81054-4	2	
14	Arm, Air Cylinder Painted	092779-1	1	
15	Bearing w/Snap Ring 6203-2RS	086395	2	
16	Washer, 17 Flat Zinc	F81058-1	2	
17	Pin, Idler Arm Mount	086404	1	
18	Nut, M16, Hex, Nylon Zinc Lock	F81036-2	2	
19	CYLINDER, HYDRAULIC COMPLETE	092788	1	
	CYLINDER, SHDJ050/030X80 HYDRAULIC	092787-1	1	
	BUSHING, TUF1 18x120 CX	500106	4	
	FITTING, HD-GE-12L-BE-06 STRAIGHT	094561	1	
	VALVE, 2901-14-17 AIR VENT	090794	1	
20	Washer, 8.4 Zinc Flat	F81054-1	6	
21	Pin, PN-EN 22341-B-18x65x57-A2	F81049-4	2	
22	Washer, 19 Flat Zinc	F81060-1	2	
23	Pin, S-Zn 5x40 PN-M/82001	F81043-31	2	
24	Pump,PMS12/TNK1 Manual w/Tank 1l	092789	1	
	Magnet, MW.38X12/N38 Neodymium	500022	1	
25	Bolt, 8mm x 1.25x35mm HH Zinc	F81002-13	4	
26	Elbow, CA-204410-3	094562	1	
27	Valve, RHV12LREDA3C Check	094559	1	
28	Hose, DN12 w/fittings PN10AOL90 M18x1,5	094565	1	
29	Latch, GN615.3-M6-KN Ball Threaded	096874	1	
30	Washer, M6, Flat, Zinc	F81053-1	7	
31	Nut, M6, Hex, Nylon Lock Zinc	F81031-2	4	
32	Bracket, Tensioner Pump Handle Bottom	096951	1	
33	Bracket, Tensioner Pump Handle Upper	092800	1	
34	Valve, ECP 20/22B2	094564	1	
35	T-connection, HD-TH-12L-BE-06	094560	1	
36	Fitting, G 3/8 Throttle	096849	1	
37	Elbow, CA-204411-3	094563	1	
38	Connector, 300.11.00 Solenoid	094555	1	
39	Pushbutton, M22 momentary, flat green	094581	1	
40	Cover, Solenoid Painted	094569-1	1	
41	Bolt, M6x60mm Hex Head, Zinc	F81001-9	3	
42	Grommet, Rubber 3/8 ID	025248	1	
43	Hose, 1/4 w/fittings JIC 7/16-20	092806	1	
44	Hose, DN12 w/fittings PN10AOL90 i PN10AOL M1.5	096964	1	
45	Hose Protection	098489	1	

3.4 Sawdust Flow Guide

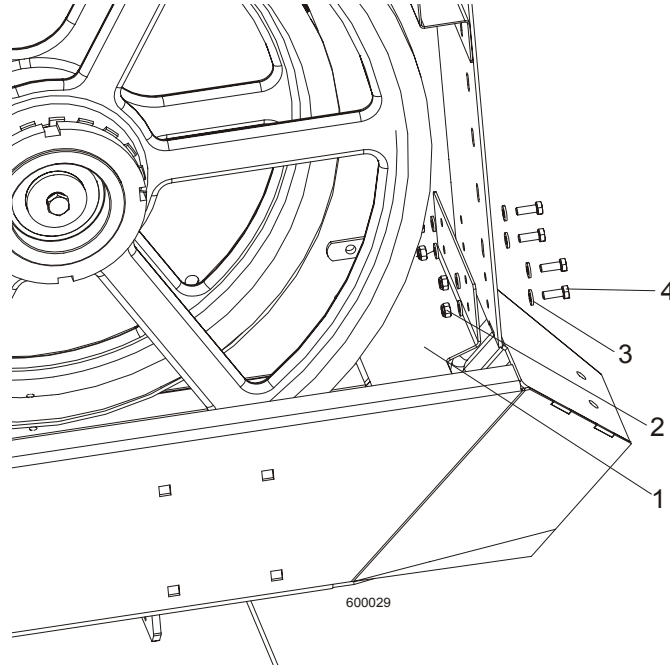

REF	DESCRIPTION (◆ Indicates Parts Available In Assemblies Only)	PART #	QTY.	
1	Guide, Sawdust Flow Painted	090506	1	
2	Nut, M6-8-B Hex Nylon Zinc Lock	F81031-2	4	
3	Washer 6.4 Zinc Flat	F81053-1	8	
4	Bolt, M6x16-8.8, Hex Head Full Thred, Zinc	F81001-32	4	

SECTION 4 SAW HEAD

4.1 Middle Throat Screw

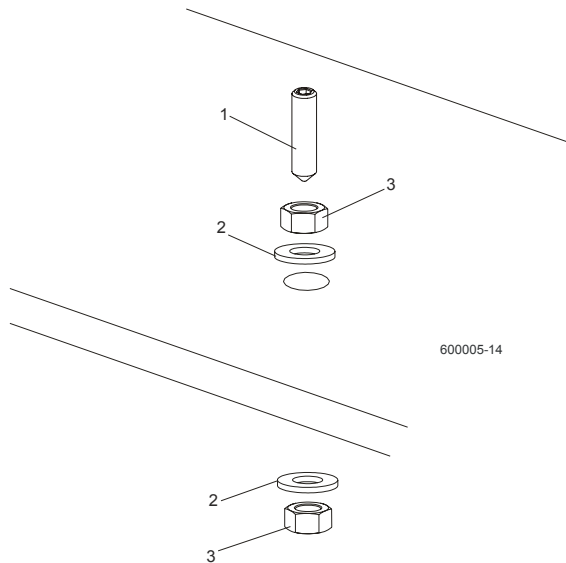

REF	DESCRIPTION (◆ Indicates Parts Available In Assemblies Only)	PART #	QTY.	
1	SCREW, M10X40-45H HEX SOCKET SET CONE POINT ZINC	F81003-61	1	
2	WASHER, 10.5 ZINC FLAT	F81055-1	2	
3	NUT, M10-8-B ZINC HEX	F81033-3	2	

4.2 Drive Belt Tensioner

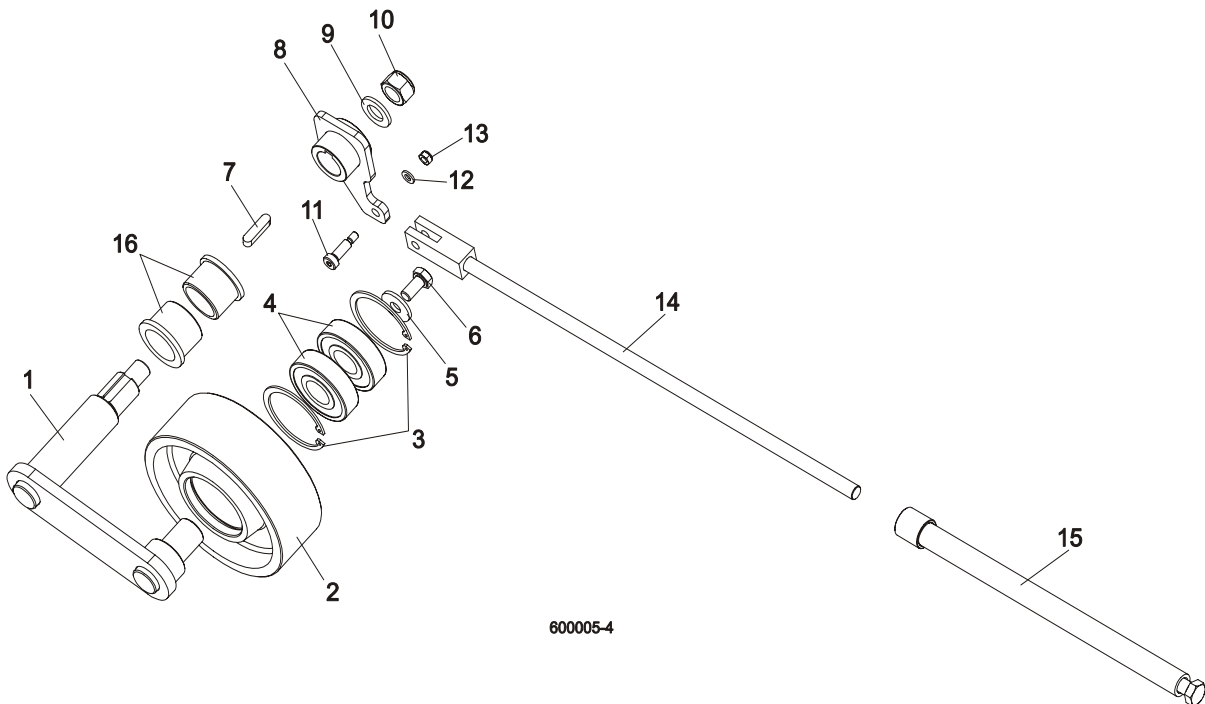

REF	DESCRIPTION (◆ Indicates Parts Available In Assemblies Only)	PART #	QTY.	
	TENSIONER ASSEMBLY, DRIVE BELT	088786	1	
1	Pivot Weldment, Drive Belt Tensioner	088810-1	1	

2	Wheel, Belt Tension	088814	1	
3	Ring, 62 mm Inside Spring Retaining	F81090-1	2	
4	Bearing, 6305 2RS NSK	P08066	2	
5	Washer, 11 Dia. Zinc Flat Special	088787-1	1	
6	Bolt, M10x20-5.8 Hex Head Full Thread Zinc	F81003-1	1	
7	Key, A8X7X32 Parallel	088564	1	
8	Arm Weldment, Drive Belt Tensioner	088807-1	1	
9	Washer, 17 Zinc Flat	F81058-1	1	
10	Nut, M16-5.8 Zinc Hex	F81036-2	1	
11	Bolt, 8/M6X20 12.9 ISO 7379 BOSSARD	F81001-25	1	
12	Washer 6.4 Zinc Flat	F81053-1	1	
13	Nut, M6-8-B Hex Nylon Zinc Lock	F81031-2	1	
14	Rod Weldment, Threaded Zinc-Plated	088789-1	1	
15	Tube Weldment, Threaded Zinc-Plated	088782-1	1	
16	BUSHING, MFM-3240-30	088461	2	

4.3 Board Return Assembly (optional)

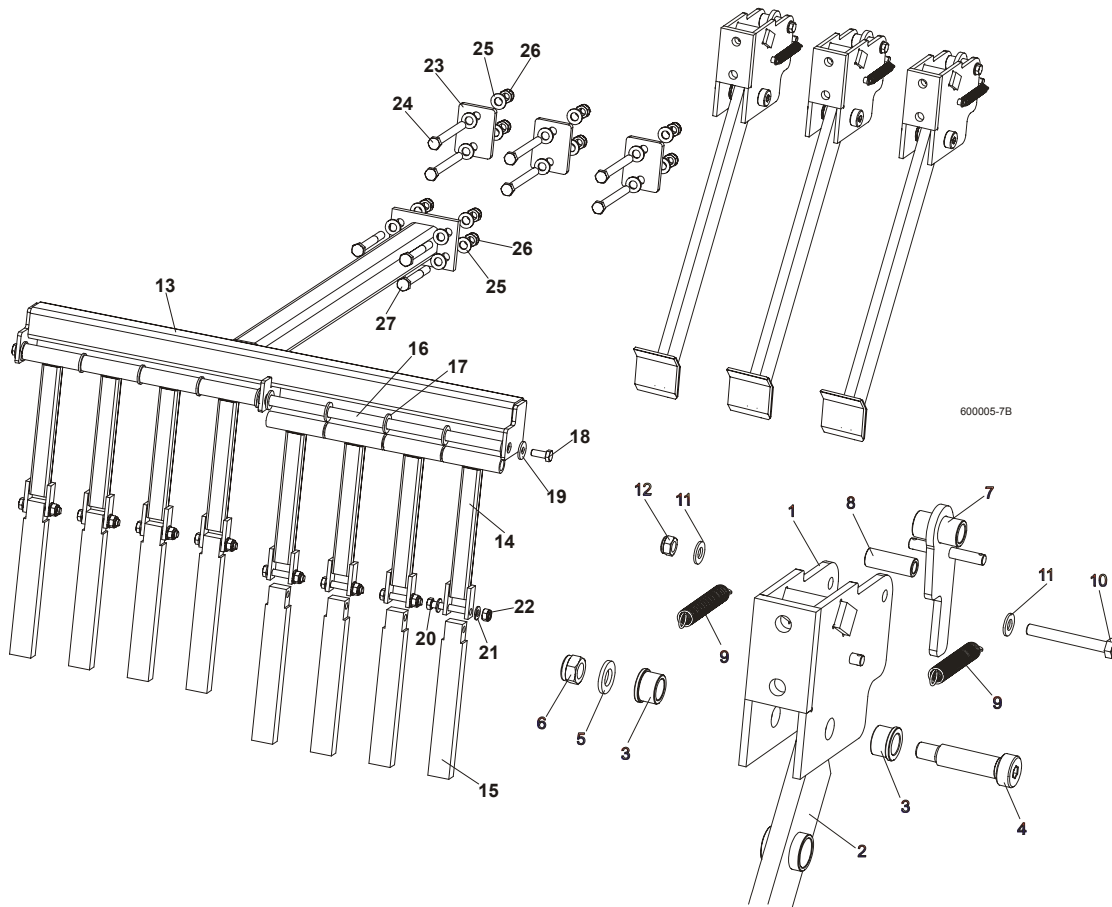

REF	DESCRIPTION (◆ Indicates Parts Available In Assemblies Only)	PART #	QTY.
	BOARD RETURN ASSEMBLY, LT70	092757	1
	Board Return Assembly	090120	3
1	Mount Weldment, Board Return Arm	090109-1	3
2	Arm, Board Return	090112-1	3
3	Bushing, Bronze	086676	6
4	Bolt, 16/M12x50-12.9 ISO7379-BOSSARD Socket Head	F81004-25	3

4

Saw Head*Board Return Assembly (optional)*

5	Washer, 13 Zinc Flat	F81056-1	3	
6	Nut, M12-8 Hex Nylon Zinc Lock	F81034-2	6	
7	Latch Weldment, Board Return Arm	090118-1	3	
8	Spacer, Zinc	090115-1	3	
9	Spring, 1/2 x 2 1/4 x 0,06 Extension	014817	6	
10	Bolt, M8 x 65-5.8 Hex Head Zinc	F81002-3	3	
11	Washer, 8.4 Zinc Flat	F81054-1	6	
12	Nut, M8-8-B Hex Nylon Zinc Lock	F81032-2	3	
	Guide, Board Return	091076	1	
13	Guide Weldment, Board Return	091067-1	1	
14	Bar Weldment, Board Guide Upper	091070-1	8	
15	Bar, Board Guide Lower Aluminium	091071	8	
16	Rod, Board Return Guide	091074	1	
17	Washer, M16, Flat Zinc	F81058-1	10	
18	Bolt, M10x25 8.8, Hex Head, Full Thrd, Zinc	F81003-31	2	
19	Washer, 10,5 Fe/Zn5	F81055-6	2	
20	Bolt, M10x60 -8.8, Hex Head, Full Thrd, Zinc	F81003-10	8	
21	Washer, M10, Flat Zinc	F81055-1	16	
22	Nut, M10, Nylon Hex Zinc Lock	F81033-1	8	
23	Washer, Special	092756-1	3	
24	Bolt, M12x120, Hex Head, Full Thrd, Zinc	F81004-38	6	
25	Washer, 13 Zinc	F81056-1	20	
26	Nut, M12 Hex Nylon Zinc Lock	F81034-2	10	
27	Bolt, M12x100, Hex Head, Full Thrd, Zinc	F81004-3	4	

4.4 Water Lube Assembly

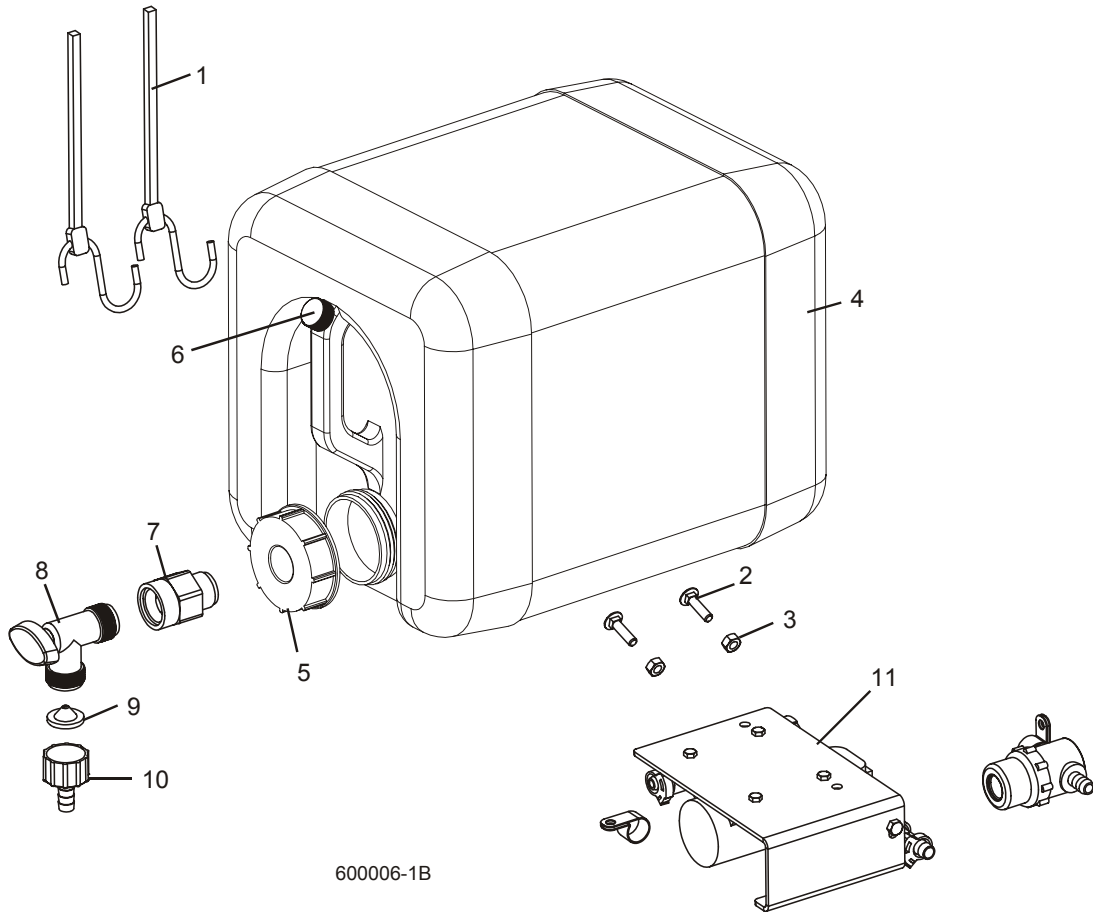

600006-1B

REF	DESCRIPTION (◆ Indicates Parts Available In Assemblies Only)	PART #	QTY.
1	STRAP, 20" RUBBER	P11668	2
2	BOLT, 1/4-20 X 1" CARRIAGE HEAD	F05005-34	2
3	NUT, 1/4-20 HEX LOCK	F05010-21	2
	BOTTLE, 5-GALLON WATER COMPLETE	014637-1	1
4	BOTTLE, 5-GALLON WATER	101295	1
5	CAP, 5-GALLON WATER BOTTLE	036745	1
6	CAP, VENT VALVE	061742	1
7	CAP, WATER LUBE BOTTLE BUTTRESS THREAD	016123	1
8	FITTING, 3/4FPT X 3/4MPT	014636	1
9	FITTING, WATER LUBE SHUTOFF VALVE	014100	1
10	FILTER, WATER LUBE	016086	1
11	FITTING, 5/8" NPT TO 3/8" HOSE BARB	014113	1
12	LUBEMIZER PARTS/HOSES (SEE LUBEMIZER OPTION MANUAL)		

4.5 LT70AC Saw Head Decals

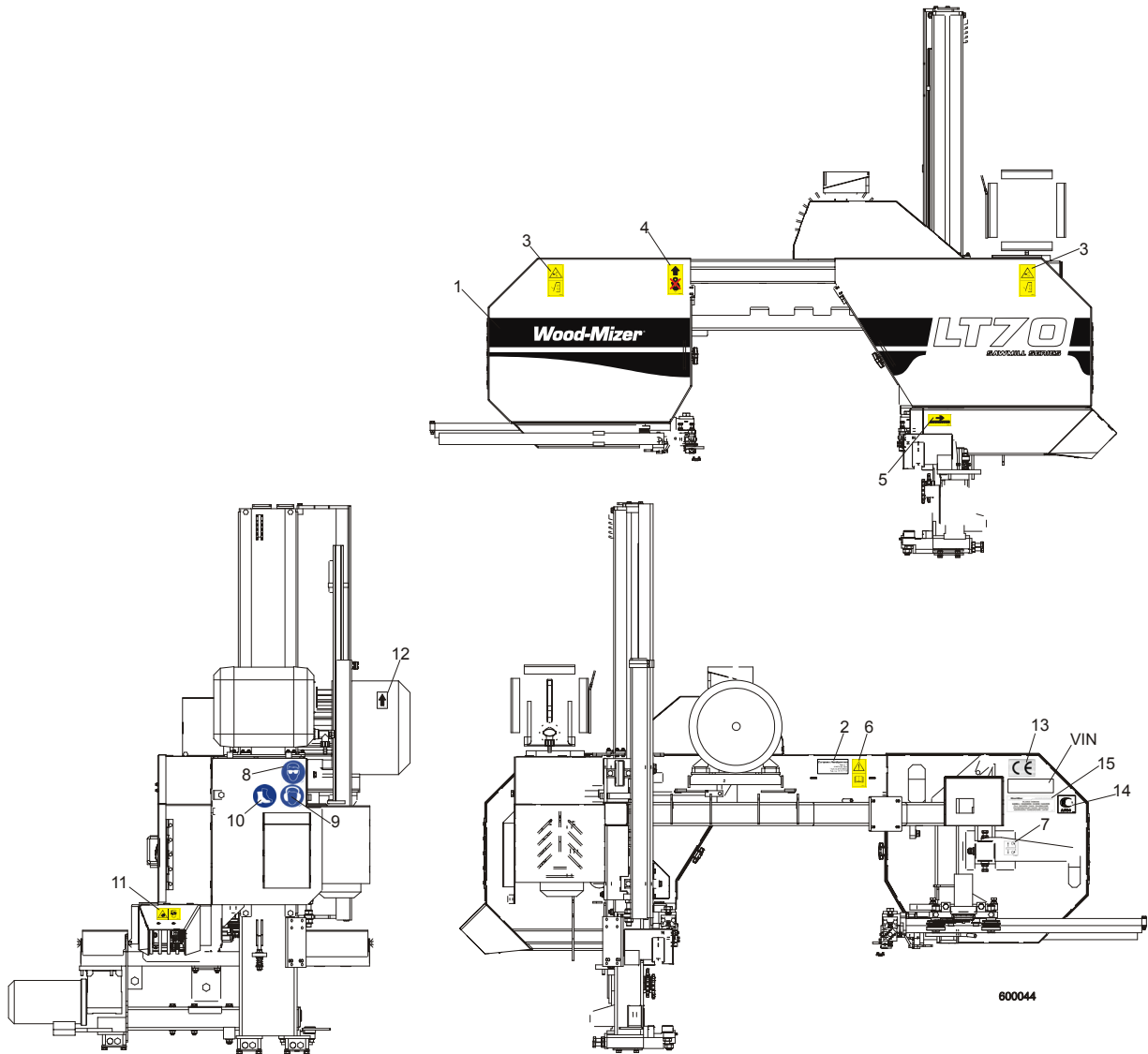

REF	DESCRIPTION (◆ Indicates Parts Available In Assemblies Only)	PART #	QTY.
1	DECAL, LT70 SERIES SAWMILL	092764	1
	PICTOGRAPHIC DECAL KIT, LT70AC	099518	1
2	DECAL, EUROPEAN HEADQUARTERS ADDRESS	015841	1
3	DECAL, SAWMILL COVERS CAUTION (PICTOGRAM)	099220	2
4	DECAL, PICTOGRAM (BLACK ARROW & HOOK)	085977B	1
5	DECAL, BLADE MOVEMENT DIRECTION (PICTOGRAM)	096321	1
6	DECAL, READ OPERATOR'S MANUAL (PICTOGRAM)	096317	1
7	DECAL, BLADE ALIGNMENT (PICTOGRAM)	P11789	1
8	DECAL, EYE PROTECTION WARNING (PICTOGRAM)	S12004G	1
9	DECAL, EAR PROTECTION WARNING (PICTOGRAM)	S12005G	1
10	DECAL, USE SAFETY BOOTS (PICTOGRAM)	501465	1
11	DECAL, SAWDUST CHUTE WARNING (PICTOGRAM)	099222	1
12	DECAL, MOTOR ROTATION DIRECTION	S20097	1
13	DECAL, CE CERTIFIED SAWMILL	P85070	1

14	DECAL, RUSSIAN SAFETY CERTIFICATION	099401	1	
15	DECAL, INTERNATIONAL SAWMILL NAME	501466	1	
	DECAL, HIGH VOLTAGE INSIDE THE ELECTRIC BOX (PICTOGRAM)	096316	2	
	DECAL, REMOVE THE PLUG BEFORE OPENING THE BOX (PICTOGRAM)	096319	2	
	DECAL, STAY A SAFE DISTANCE FROM THE BLADE (FOR DEBARKERS)	098176	1	
	DECAL, BLADE SETTING	P85066-70	1	

4.6 Blade Housing Covers

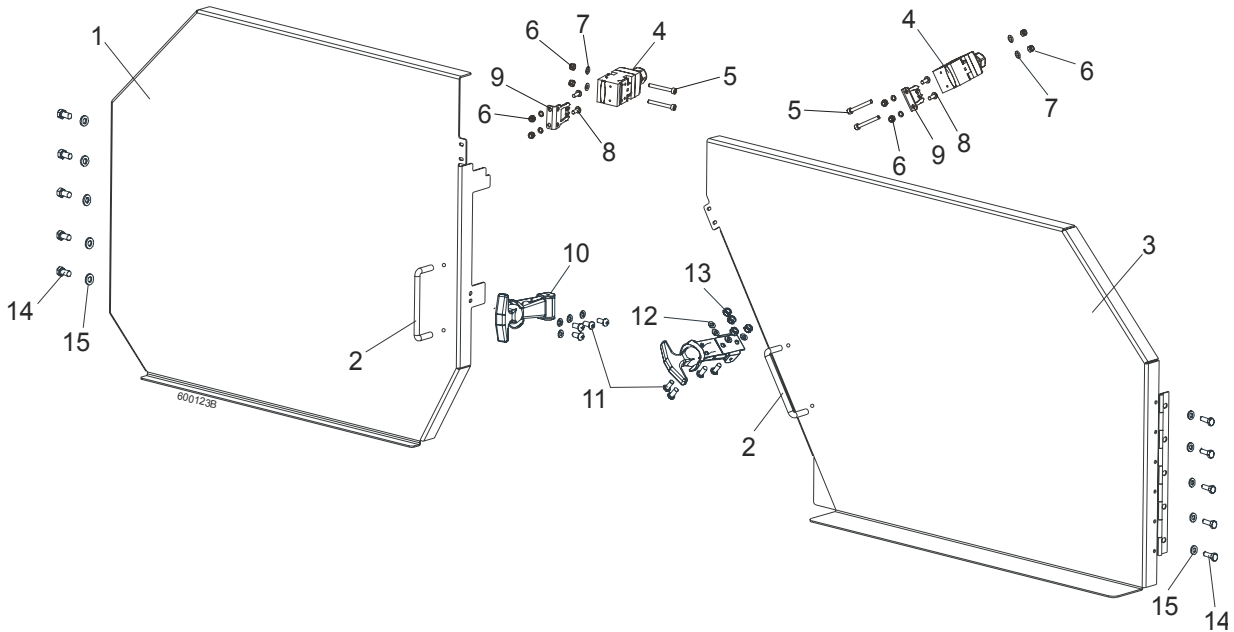

REF	DESCRIPTION (◆ Indicates Parts Available In Assemblies Only)	PART #	QTY.
	COVER ASSEMBLY, IDLE SIDE BLADE HOUSING	088920	1
1	Cover Assembly, Idle Side Blade Housing, Ptd	088915-1	1
2	Handle, Blade Housing Cover	P08065	1
	COVER ASSEMBLY, DRIVE SIDE BLADE HOUSING	088921	1
3	Cover Assembly, Drive Side Blade Housing, Ptd	088917-1	1
2	Handle, Blade Housing Cover	P08065	1
4	LIMIT SWITCH, HONEYWELL GKMB 23W2	086681	2
5	BOLT, M4 X 35-8.8 SOCKET HEAD	F81011-34	4
6	NUT, M4-B HEX NYLON ZIN	F81028-2	8
7	WASHER 4,3 ZINC, FLAT	F81051-2	8
8	SCREW, M4 X 12-5.8	F81011-41	4
9	KEY, AZ17/170-B5 SAFETY SWITCH	094422	4
10	LATCH, FLEXIBLE DRAW	014829	2
11	BOLT, M5X12-5.8	F81000-5	8
12	WASHER 5,3 ZINC FLAT	F81052-1	8
13	NUT M5-8 DIN 985 ZINC	F81030-2	8
14	BOLT, M6X16 8.8 HEX HEAD FULL THREAD ZINC	F81001-15	10
15	WASHER 6.4 ZINC FLAT	F81053-1	10

4.7 Sawdust Chute

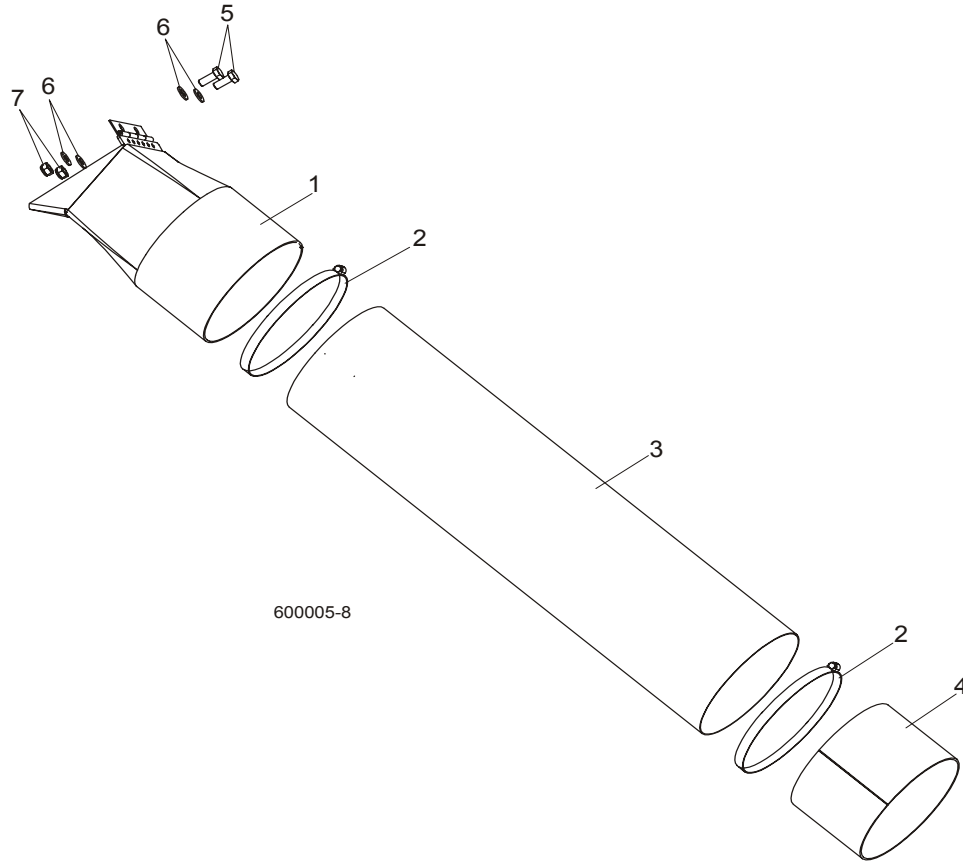

REF	DESCRIPTION (◆ Indicates Parts Available In Assemblies Only)	PART #	QTY.	
1	CHUTE WELDMENT, SAWDUST	089352-1	1	
2	CLAMP, 152 MM	089358	2	
3	TUBE, SAWDUST CHUTE	090153	1	
4	TUBE, CHUTE END	090126-1	1	
5	BOLT, M8X20-8.8-B HEX HEAD FULL THREAD ZINC	F81002-4	2	
6	WASHER 8.4 ZINC FLAT	F81054-1	4	
7	NUT, M8-8-B HEX NYLON ZINC LOCK	F81032-2	2	

SECTION 5 CONTROL BOXES

5.1 Control Assembly, LT70 AH

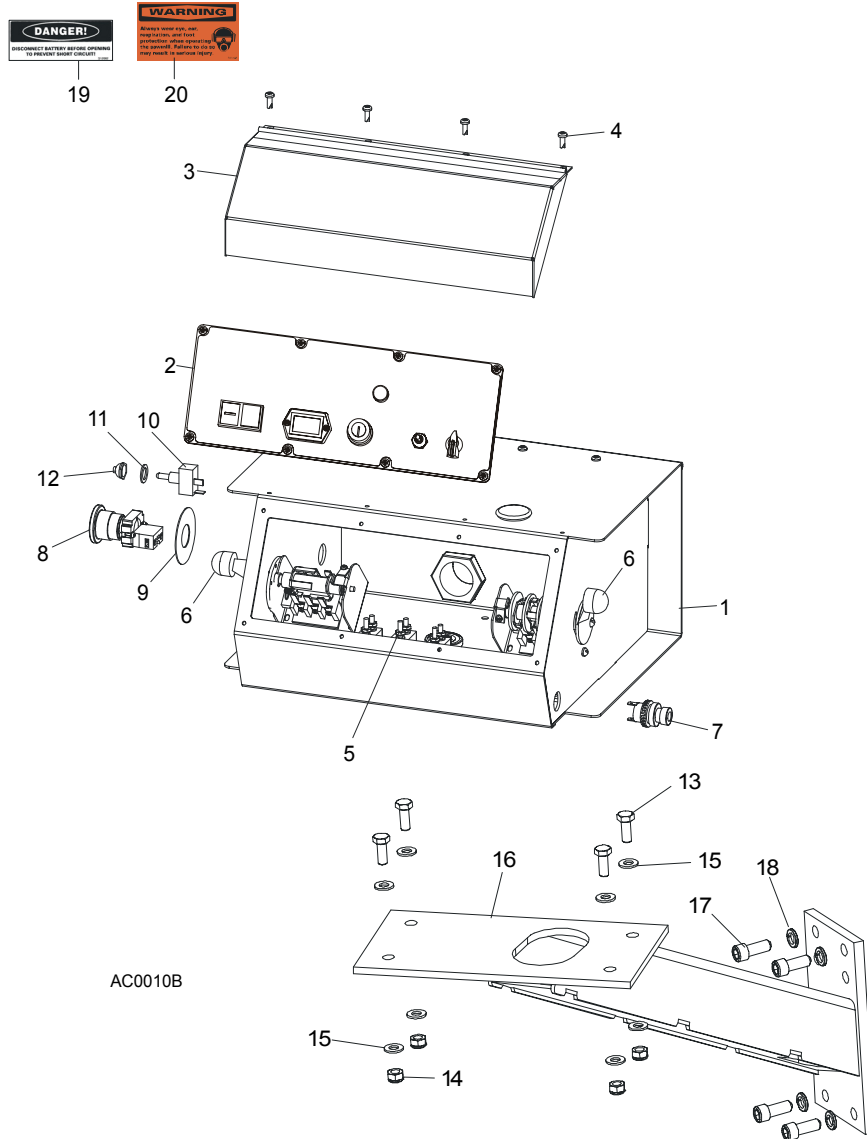

AC0010B

REF	DESCRIPTION (◆ Indicates Parts Available in Assemblies Only)	PART #	QTY.	
	CONTROL BOX ASSEMBLY, AC SUPER (EA20, EA25)	093022	1	
1	HOUSING, AC SUPER CONTROL BOX ASSEMBLY (EA20, EA25)	086546-1	1	◆
2	Front Control Panel & Wiring Harnesses (Section 5.4)			
3	Cover, Control Box Hinged	015304	1	
4	Screw, #10-24 x 1/2"	F05015-17	12	
5	Circuit Breakers (Section 5.3)			
6	Drum Switches (Section 5.2)			
7	Switch, Horn	E85118	1	
8	Switch, XB2 BS542 Emergency Stop	086556	1	
9	Washer, Emergency Stop Switch	086561	1	
10	Switch, Speed Control	086773	1	
11	Washer, 1/2" x 3/4" x 5/8" Nylon	P05251-1	1	

12	Boot, Speed Control Switch	P02575	1	
13	BOLT, M8 X 20-8.8-B HEX HEAD	F81002-4	4	
14	NUT, M8-8-B HEX	F81032-2	4	
15	WASHER, 8.4 FLAT	F81054-1	8	
16	MOUNT WELDMENT, STANDARD CONTROL BOX	086732-1	1	
17	BOLT,, 3/8-16 X 1" SOCKET HEAD	F05007-52	4	
18	WASHER, 10.2 SPLIT LOCK	F81055-2	4	
19	DECAL, FRONT OUTRIGGER WARNING	015400-4	1	
20	DECAL, EAR/EYE PROTECTION WARNING	S11753-4	1	

5.2 Drum Switches

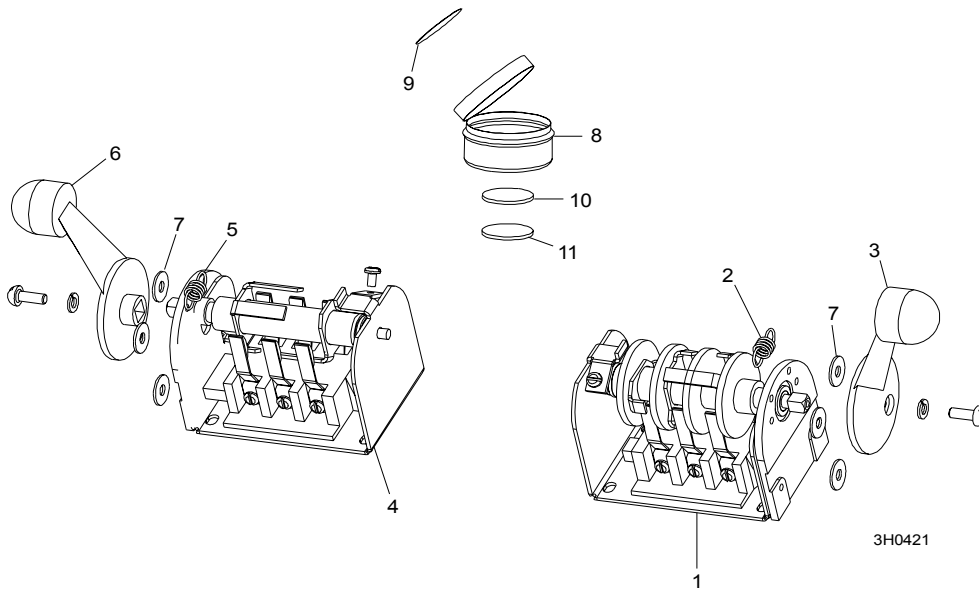

REF	DESCRIPTION (◆ Indicates Parts Available In Assemblies Only)	PART #	QTY.	
	SWITCH ASSEMBLY, UP/DOWN DRUM	E20440	1	
1	Switch, S12 Bulk Drum	E20440-B	1	◆
2	Spring, Drum Switch	P12570	1	
3	Handle, Drum Switch Replacement	P12500	1	
	SWITCH ASSEMBLY, POWER FEED DRUM	E20438	1	
4	Switch, S10 Bulk Drum	E20438-B	1	◆
5	Spring, Drum Switch	P12570	1	
6	Handle, Drum Switch Replacement	P12500	1	
7	WASHER, #8 SAE FLAT	F05011-41	6	
	CUP ASSEMBLY, DRUM SWITCH GREASE	A20463	1	
8	Cup, Plastic Container	P20464	1	◆
9	Decal, Grease Cup Label	P20467	1	
10	Pad, Velcro Loop	P20466	1	◆
11	Pad, Velcro Hook	P20465	1	◆
	Grease, High Temp Drum Switch	P20468	.011ml	◆

5.3 Circuit Breakers

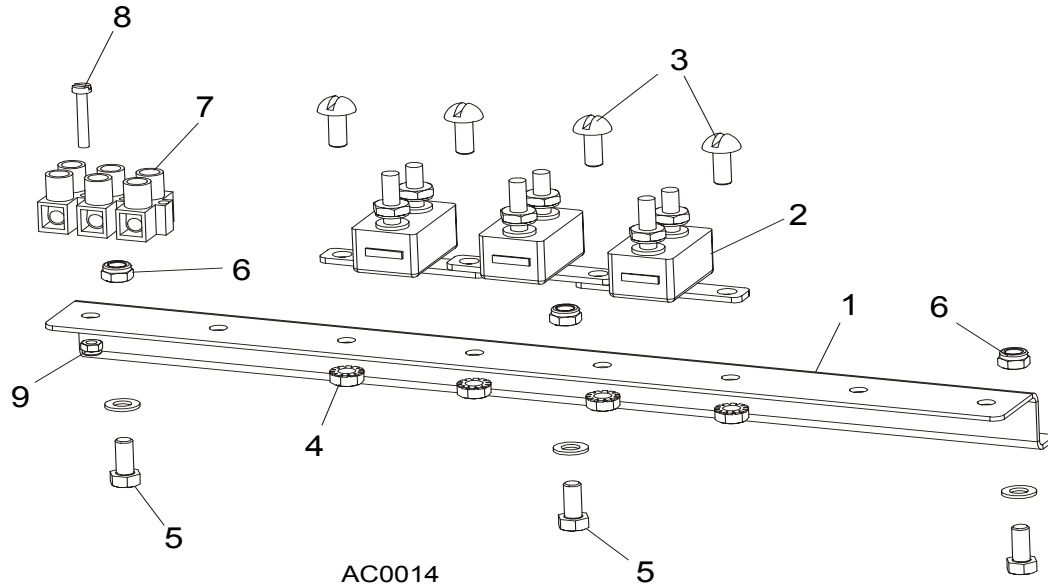

REF	DESCRIPTION (◆ Indicates Parts Available In Assemblies Only)	PART #	QTY.
	BREAKER ASSEMBLY, SAWMILL CONTROL CIRCUIT	015621	1
1	Rail, Circuit Breaker	015310	1
2	Breaker, 15 Amp Manual Reset	E20430	5
3	Screw, #8-32 X 1/2" Slotted Head	F05004-12	6
4	Nut, #8-32 Hex Self-Locking	F05010-41	6
5	BREAKER, 70 AMP MANUAL RESET PANEL MOUNT	015527	1
6	BREAKER, 50 AMP MANUAL RESET PANEL MOUNT	021256	1
7	BOOT, CIRCUIT BREAKER	021253	2
8	SCREW, #10-24 X 3/8" PHILLIPS PAN HEAD	F05004-3	3
9	NUT, #10-24 SELF LOCKING	F05010-14	3

5.4 Front Panel Assembly & Harnesses

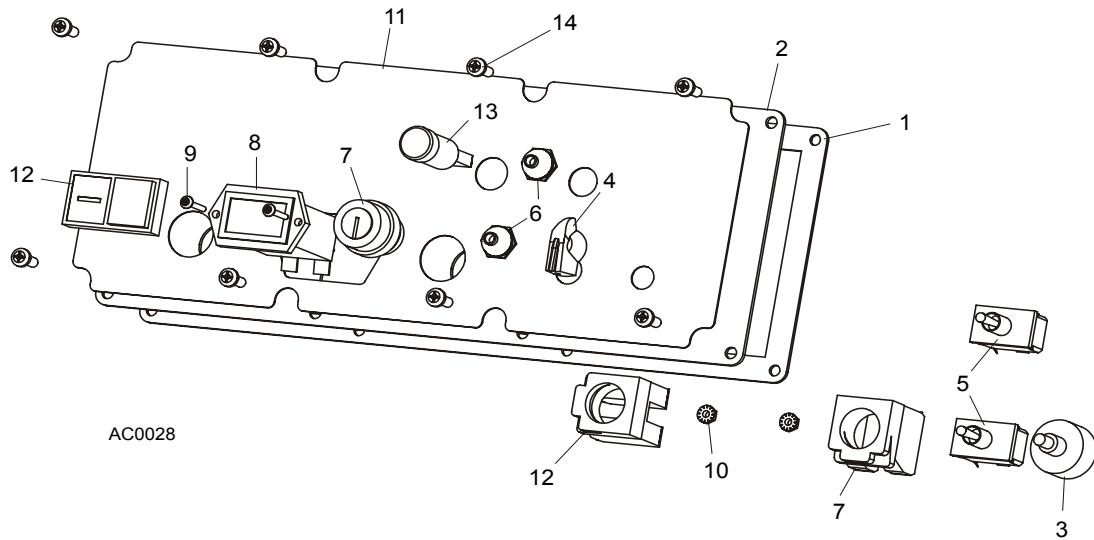

REF	DESCRIPTION (◆ Indicates Parts Available In Assemblies Only)	PART #	QTY.
	PANEL ASSEMBLY, AC SUPER CONTROL FRONT (EA20, EA25)	087387	1
1	Gasket, Front Panel	088387	1
2	Panel Weldment, Control	087316	1
3	Switch Assembly, Feed Rate	E20519	1
4	Knob, Feed Rate With Set Screw	P06257	1
5	Switch, Toggle	024200	2
6	Boot, Toggle Switch Rubber	P02575	2
7	Switch, Key	087350	1
8	Meter, Hour	015401	1
9	Screw, 6-32 x 3/4" Socket Button Head Cap Stainless Steel	F05004-93	2
10	Nut, # 6-32 Keps	F05010-59	2
11	Decal, Control Pane	087351	1
12	Switch, START-STOP	087349	1
13	Lamp, Control	087348	1
	HARNESS ASSEMBLY, UPPER WIRING	093167	1
14	Screw, #10-24 x 1/2" Pan Head	F05015-17	8

5.5 Solenoids

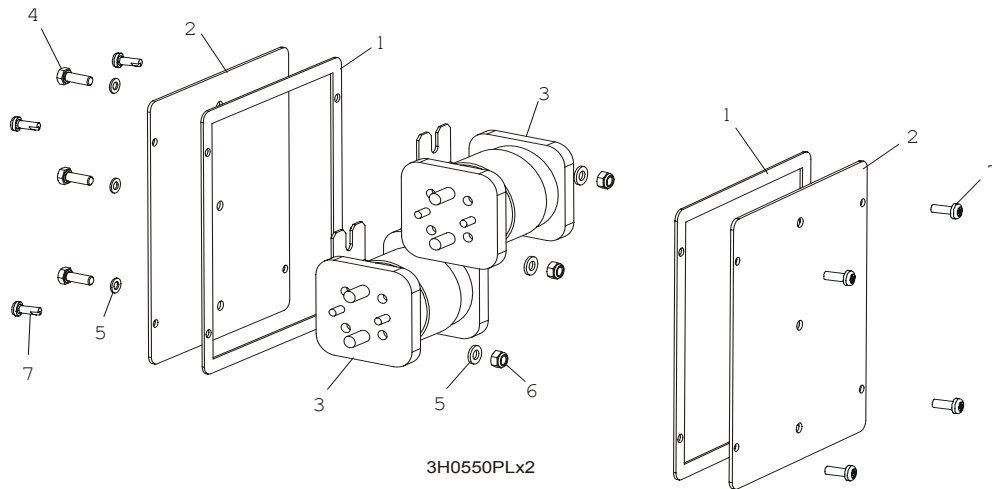

REF	DESCRIPTION (◆ Indicates Parts Available In Assemblies Only)	PART #	QTY.	
1	GASKET, SIDE PANEL	015274	2	
2	PANEL WELDMENT, SIDE	015307	2	
3	SOLENOID, 200A 12V SPST HYDRAULIC PUMP	015470	2	
4	BOLT, M6X16 5.8 HEX HEAD FULL THREAD ZINC	F81001-14	3	
5	WASHER, 6.4 FLAT ZINC	F81053-1	6	
6	NUT, M6-8-B HEX NYLON ZINC LOCK	F81031-2	3	
	DIODE ASSEMBLY, SOLENOID COIL CHASSIS GND	087496	4	
7	BOLT, #10-24 X 1/2 PHILLIPS PAN HEAD TYPE 23	F05015-17	8	

SECTION 6 UP/DOWN SYSTEM

6.1 Up/Down Rollers & Covers

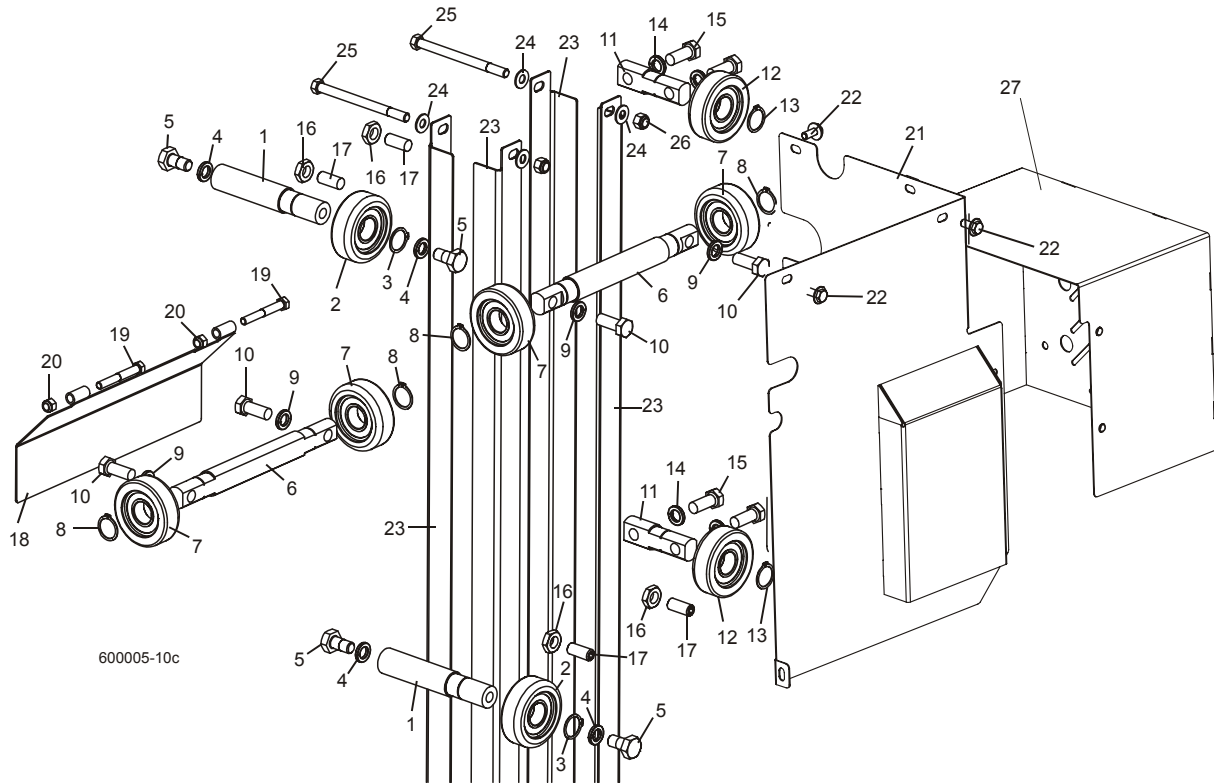

REF	DESCRIPTION (◆ Indicates Parts Available in Assemblies Only)	PART #	QTY.
	ROLLER ASSEMBLY, INSIDE UP/DOWN	089456	2
1	Shaft, Inside Up/Down Roller	088817-1	1
2	Bearing, CBK-468 Rolling	088433	1
3	Ring, Z30 Spring Retaining	F81090-23	1
4	Washer, 13 Zinc Flat	F81056-1	2
5	Bolt, M12x25-8.8 Hex Head Full Thread Zinc	F81004-31	2
	ROLLER ASSEMBLY, OUTSIDE UP/DOWN	089454	2
6	Shaft, Long Up/Down Roller	088815-1	1
7	Bearing, CBK-468 Rolling	088433	2
8	Ring, Z30 Spring Retaining	F81090-23	2
9	Washer, 10.5 Zinc Flat	F81055-1	3
10	Bolt, M10x35-8.8 Hex Head Full Thread Zinc	F81003-17	3
	ROLLER ASSEMBLY, SHORT UP/DOWN	089455	2
11	Shaft, Short Up/Down Roller	088816-1	1
12	Bearing, CBK-468 Rolling	088433	1
13	Ring, Z30 Spring Retaining	F81090-23	1
14	Washer, 10.5 Zinc Flat	F81055-1	2
15	Bolt, M10x35-8.8 Hex Head Full Thread Zinc	F81003-17	2
16	NUT, M10-04-W HEX ZINC THIN	F81033-6	4
17	SCREW, GN 913.3-M10-40-MS SET	F81003-65	4
18	COVER WELDMENT, UP/DOWN ROLLER	089483-1	1
19	BOLT, M8X16-8.8-B HEX HEAD FULL THREAD ZINC	F81002-20	4
20	WASHER, 8.4 ZINC FLAT	F81054-1	9

21	GUARD WELDMENT, RA-08 UP/DOWN GEAR BOX SIDE PTD	091319-1	1	
22	BOLT, M8X12-8.8 HEX HEAD FULL THREAD ZINC	F81002-6	5	
23	ANGLE, MAST TUBE STAINLESS	088492	4	
24	WASHER, 10.5 ZINC FLAT	F81055-1	12	
25	BOLT, M10X125-8.8 HEX HEAD ZINC	F81003-18	4	
26	NUT, M10-8-B HEX NYLON ZINC LOCK	F81033-1	4	
27	GUARD, UP/DOWN MOTOR PAINTED	090501-1	1	

6.2 Blade Height Scale

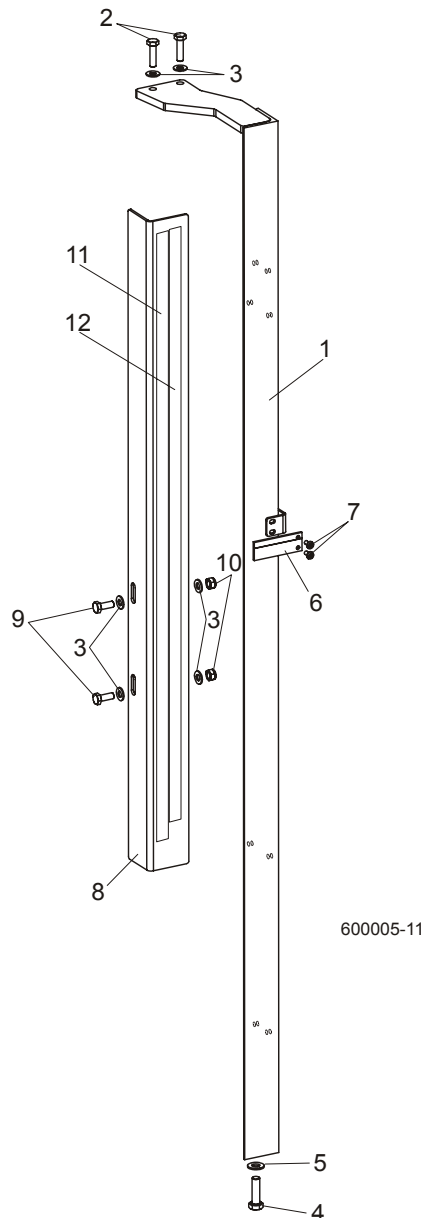

REF	DESCRIPTION (◆ Indicates Parts Available In Assemblies Only)	PART #	QTY.	
1	MOUNT WELDMENT, SCALE PAINTED	088554-1	1	
2	BOLT, M8 x 30-8.8-B HEX HEAD FULL THREAD ZINC	F81002-7	2	
3	WASHER, 8.4 ZINC FLAT	F81054-1	6	
4	BOLT, M10 x 35-8.8 HEX HEAD FULL THREAD ZINC	F81003-17	1	
5	WASHER, 10.5 ZINC FLAT	F81055-1	1	

6	INDICATOR, BLADE HEIGHT SCALE	094821	1	
7	SCREW, #10-24 X 3/8 PHILLIPS PAN HEAD ZINC	F05004-3	2	
8	ANGLE, SCALE MOUNT	088785-1	1	
9	BOLT, M8 X 20-8.8-B HEX HEAD FULL THREAD ZINC	F81002-4	2	
10	NUT, M8-8-B HEX NYLON ZINC LOCK	F81032-2	2	
11	DECAL, METRIC SCALE	S11711	1	
12	DECAL, 16-40 MM METRIC SCALE	P12040-1	1	

6.3 Up/Down Chain & Sprockets

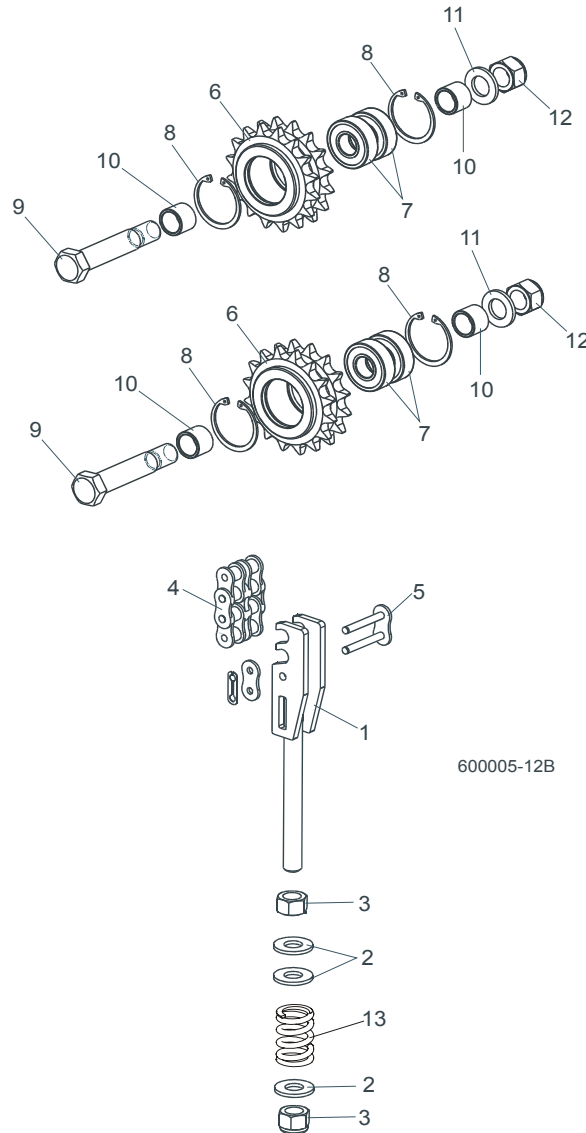

REF	DESCRIPTION (◆ Indicates Parts Available In Assemblies Only)	PART #	QTY.	
1	TENSIONER WELDMENT, UP/DOWN CHAIN ZINC	088551-1	1	
2	WASHER, 13 ZINC FLAT	F81056-1	3	
3	NUT, M12-8 HEX NYLON ZINC LOCK	F81034-2	2	
4	CHAIN, 10B-2 113-LINK UP/DOWN	088672	1	
5	LINK, 10B-2Pz MASTER	088673	1	
	SPROCKET ASSEMBLY, UP/DOWN IDLER	088470	2	
6	Sprocket, Zinc	088471-1	1	
7	Bearing, 6203-2RS FLT Rolling	086114	2	

8	Ring, W40 Spring Retaining	F81090-3	2	
9	Bolt, M16D1F6 x 90-8.8 Hex Fit Short Thread Zinc	F81006-15	1	
10	Spacer, Idler Zinc	088792-1	2	
11	Washer, 17 Zinc Flat	F81058-1	1	
12	Nut, M16-8 Hex Nylon Zinc Lock	F81036-2	1	
13	Spring, 14x30x3,2	090797	1	

6.4 Up/Down Drive Assembly

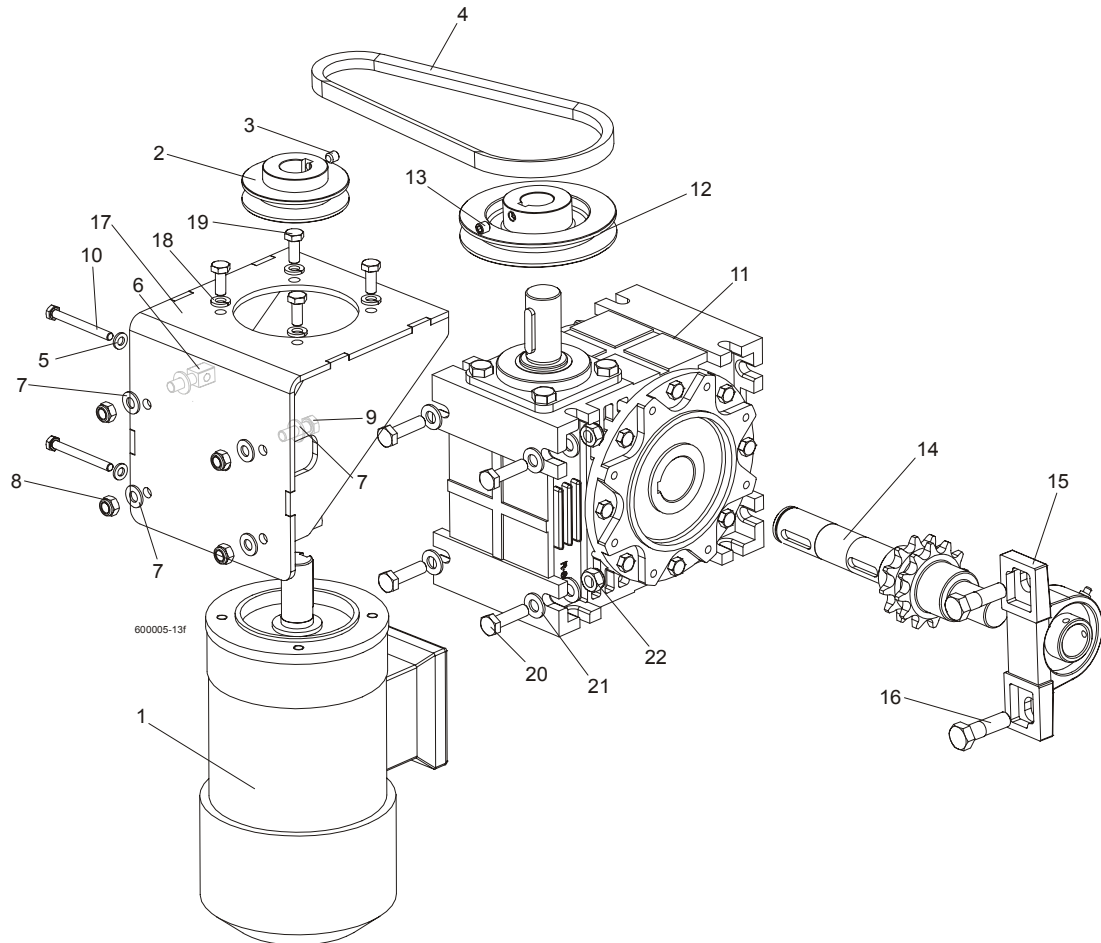

REF	DESCRIPTION (◆ Indicates Parts Available In Assemblies Only)	PART #	QTY.	
	MOTOR W/MOUNT BRACKET, AC UP/DOWN	090493	1	
1	AC Motor, 2 gear STKg90 6/4L2 IMB14/162	086530	1	
2	Pulley, AC Motor Painted	090497-1	1	
3	Screw, M8x8-33H Hex Socket Set Flat Point Zinc	F81014-1	1	
4	V-Belt, HA-670	091328	1	
5	Washer, 6.4 Zinc Flat	F81053-1	2	
6	Bolt, Special - Zinc Plated	088962-1	2	
7	Washer, 8.4 Zinc Flat	F81054-1	8	
8	Nut, M8-8-B Hex Nylon Zinc Lock	F81032-2	4	
9	Bolt, M8X25-8.8-B Hex Head Full Thread Zinc	F81002-5	2	
10	Bolt, M6x60-8.8 Hex Head Full Thread Zinc	F81001-9	2	
	GEAR BOX ASSEMBLY, UP/DOWN DRIVE	091310	1	
11	Gear Box, R80/64/WBS/D1,N+S,V5	097701	1	
12	Pulley, Up/Down Gear Painted	091308-1	1	

13	Screw, M8x8-33H Hex Socket Set Flat Point Zinc	F81014-1	1	
14	Output Shaft W/Sprocket, Up/Down Drive	091311	1	
15	Bearing Assembly, UCP205 CX	088468	1	
16	Bolt, M12 x 40-8.8 Hex Head Zinc	F81004-1	1	
17	BRACKET, AC UP/DOWN MOTOR MOUNT PTD	090494-1	1	
18	WASHER 8.2 SPLIT LOCK ZINC	F81054-4	4	
19	BOLT, M8 X 20-8.8-B HEX HEAD FULL THREAD ZINC	F81002-4	4	
20	BOLT M10x35-8.8 HEX HEAD FULL THREAD ZINC	F81003-17	4	
21	WASHER 10,5Fe/Zn5, SPECIAL	F81055-4	8	
22	NUT,M10-8-B NYLON HEX ZINC LOCK	F81033-1	4	

SECTION 7 FEED SYSTEM & TRACK ROLLERS

7.1 Upper Track Rollers And Wipers

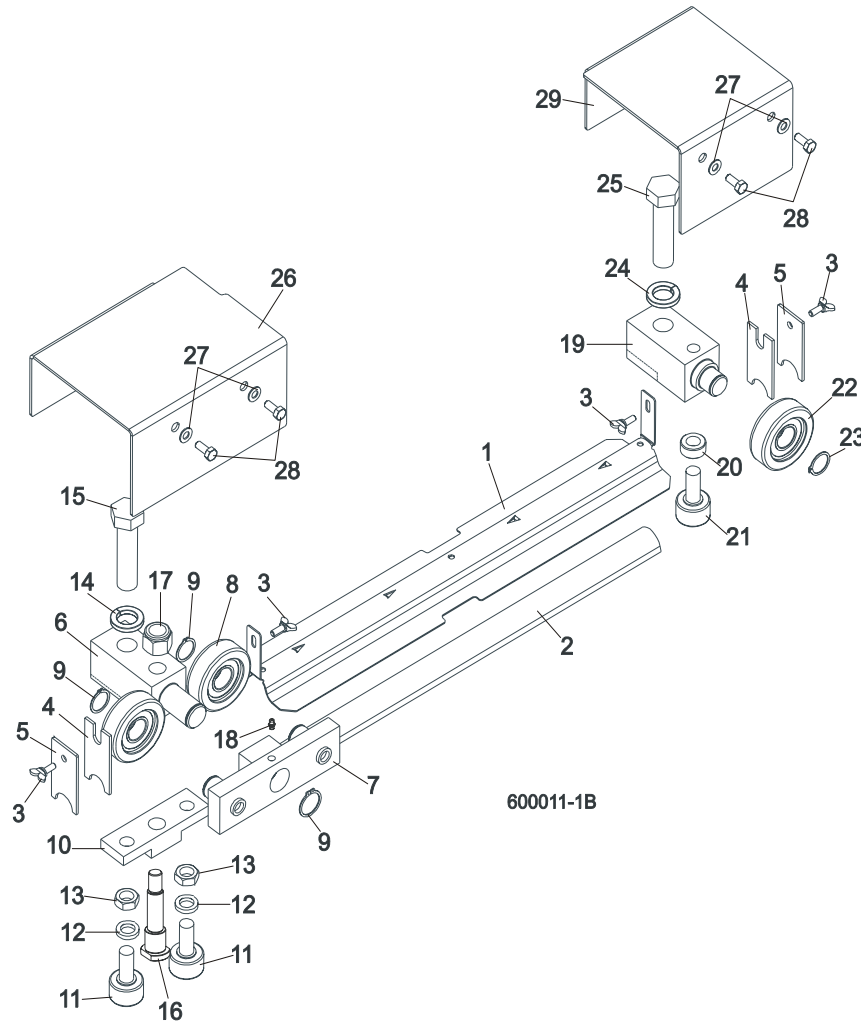

REF	DESCRIPTION (◆ Indicates Parts Available In Assemblies Only)	PART #	QTY.
1	COVER, LT40/70 MIDDLE TRACK - SERVICE	092868-S	1
	Cover, LT40/70 Middle Track Ptd	092868-1	1
2	Strip, 3/16 X 2 X 23 Felt	S09915	1
3	SCREW, M6X16 DIN 316 WING	F81001-16	4
4	WIPER, TOP RAIL	M04113	2
5	PLATE, TRACK WIPER	088559-1	2
	ROLLER ASSEMBLY, UPPER TANDEM TRACK	088530	1
6	Block, Tandem Roller Mount	088532	1
7	Block Assembly, Tandem Roller	088535	1
8	Bearing, CBK-468 Rolling	088433	2
9	Ring, Z30 Spring Retaining	F81090-23	2
10	Block, Cam Follower Mount	088520	1
11	Bearing, Cam Follower (McGill)	012797	2
12	Washer, 16.3 Split Zinc Lock	F81058-2	2
13	Nut, 5/8"-18 Zinc	F05010-11	2
14	Washer, Z24.5 Split Zinc Lock	F81061-4	1
15	Bolt, M24 x 2 x 90-8.8 Hex Head Full Thread Zinc	F81009-2	1

16	Pin, Cam Follower Mount	088531	1	
17	Nut, M16-8 Hex Nylon Zinc Lock	F81036-2	1	
18	Fitting, M6 Straight Grease	086280	1	
	ROLLER ASSEMBLY, REAR UPPER TRACK	088529	1	
19	Block, Rear Upper Roller Mount	088528	1	
20	Spacer, Cam Follower	088536	1	
21	Bearing, Cam Follower (McGill)	012797	1	
22	Roller, CBK-468	088433	1	
23	Ring, Z30 Spring Retaining	F81090-23	1	
24	Washer, Z24.5 Split Zinc Lock	F81061-4	1	
25	Bolt, M24x2x90-8.8 Hex Head Full Thread Zinc	F81009-2	1	
26	COVER, TANDEM ROLLER	088526-1	1	
27	WASHER, 6.4 ZINC FLAT	F81053-1	4	
28	BOLT, M6X16 8.8 HEX HEAD FULL THREAD ZINC	F81001-15	4	
29	COVER, REAR UPPER ROLLER	088527-1	1	

7.2 Power Feed Assembly

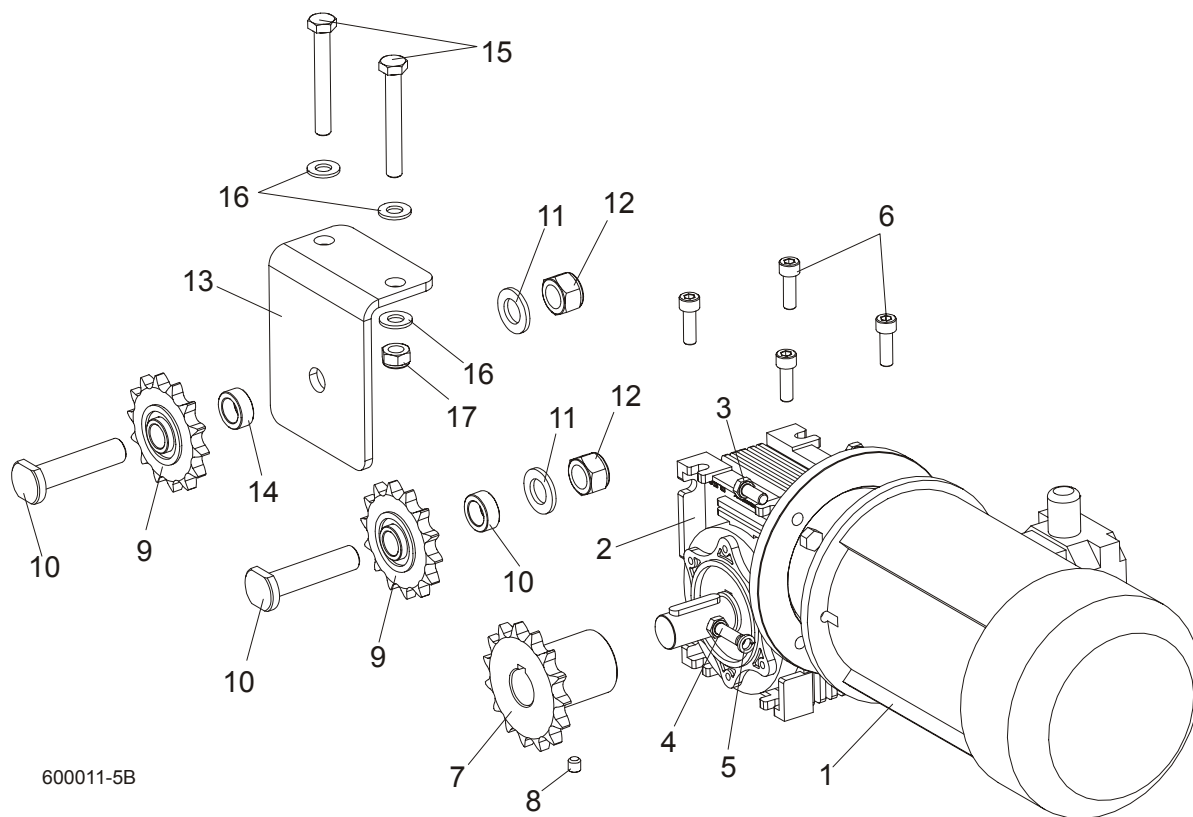

REF	DESCRIPTION (◆ Indicates Parts Available In Assemblies Only)	PART #	QTY.
	MOTOREDUCER MR-50/7.5/1.1-1380/K3/B8	100936	1
1	Electric motor 1,1kW AC	090104	1
2	RA-0,5/7,5/D3/S/B8 I.3 koln.160/19 B14/1	100935	1
3	BOLT, M8X20MM, HEX HEAD,GR 5.8 ZINC	F81002-4	2
4	BOLT,M8X25-8.8-B HEX HEAD FULL THREAD	F81002-5	2
5	WASHER 8,2 FE/ZN9	F81054-4	2
6	SCREW, M8x25 -8.8 HEX SOCKET HEAD CAP	F81002-21	4
7	SPROCKET, 10B Z15 ZINC	088541-1	1
8	SCREW, M8x8-33H HEX SOCKET SET FLAT POINT ZINC	F81014-1	2
9	SPROCKET, KSR 16.L0.10.10.14.08 W/BEARING	088867	2
10	PIN, ZINC SPROCKET MOUNT	088994-1	2
11	WASHER, 17 ZINC FLAT	F81058-1	2
12	NUT, M16-8 HEX NYLON ZINC LOCK	F81036-2	2
13	BRACKET, POWER FEED SPROCKET MOUNT	088507-1	1
14	SPACER, POWER FEED SPROCKET	088550-1	1
15	BOLT, M10x75-8.8 HEX HEAD ZINC	F81003-15	2
16	WASHER, 10.5 ZINC FLAT	F81055-1	4
17	NUT, M10-8-B HEX NYLON ZINC LOCK	F81033-1	2

7.3 Feed Chain/Stop, LT70 S/M

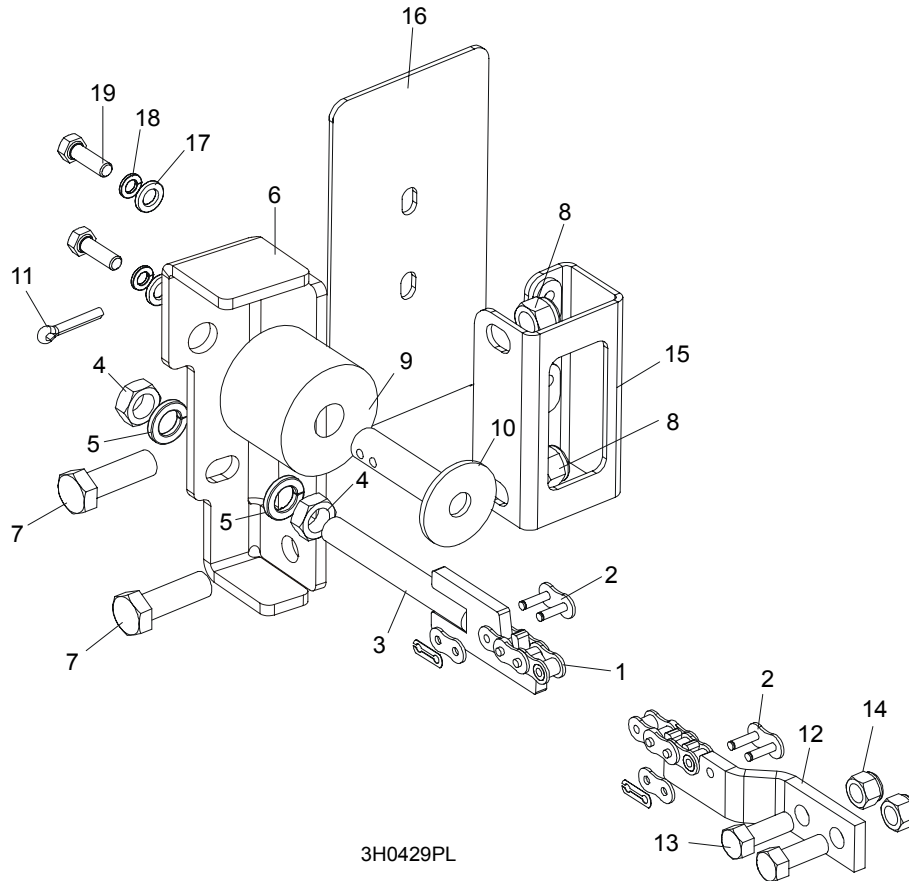

3H0429PL

REF	DESCRIPTION (◆ Indicates Parts Available In Assemblies Only)	PART #	QTY.
1	CHAIN, 10B-1-375 (5.95M) LT70S FEED	090427	1
	CHAIN, 10B-1-457 (7.25M) LT70M FEED	090370	1
2	LINK, 10B-1Pz MASTER	088671	2
3	TENSIONER WELDMENT, POWER FEED CHAIN ZINC-PLATED	086818-1	1
4	NUT, M12-5 HEX JAM	F81034-4	2
5	WASHER, 12.2 SPLIT LOCK	F81056-2	2
6	BRACKET, FEED CHAIN REAR MOUNT	087628-1	1
7	BOLT, M12 X 40 8.8 HEX HEAD GRADE 5	F81004-4	2
8	NUT, M12-8 HEX NYLON LOCK	F81034-2	2
	STOP KIT, RUBBER CARRIAGE	K09630	2
9	Stop, Rubber Carriage	P12165	1
10	Pin, Rubber Carriage Stop	W09293	1
11	Pin, 3/16" X 1" Cotter	F05012-21	1
12	BRACKET, FRONT FEED CHAIN MOUNT	015008	1
13	BOLT, 3/8-16 X 1" HEX HEAD	F05007-7	2
14	NUT, 3/8-16 HEX NYLON LOCK	F05010-10	2
15	BRACKET WELDMENT, REAR MAIN TUBE COVER MOUNT	087105-1	1
16	COVER, REAR MAIN TUBE	015023	1
17	WASHER, 8.4 FLAT	F81054-1	2
18	WASHER, 8.2 SPLIT LOCK	F81054-4	2
19	BOLT, 5/16-18 X 1" HEX HEAD	F05006-1	2

7.4 Lower Track Rollers

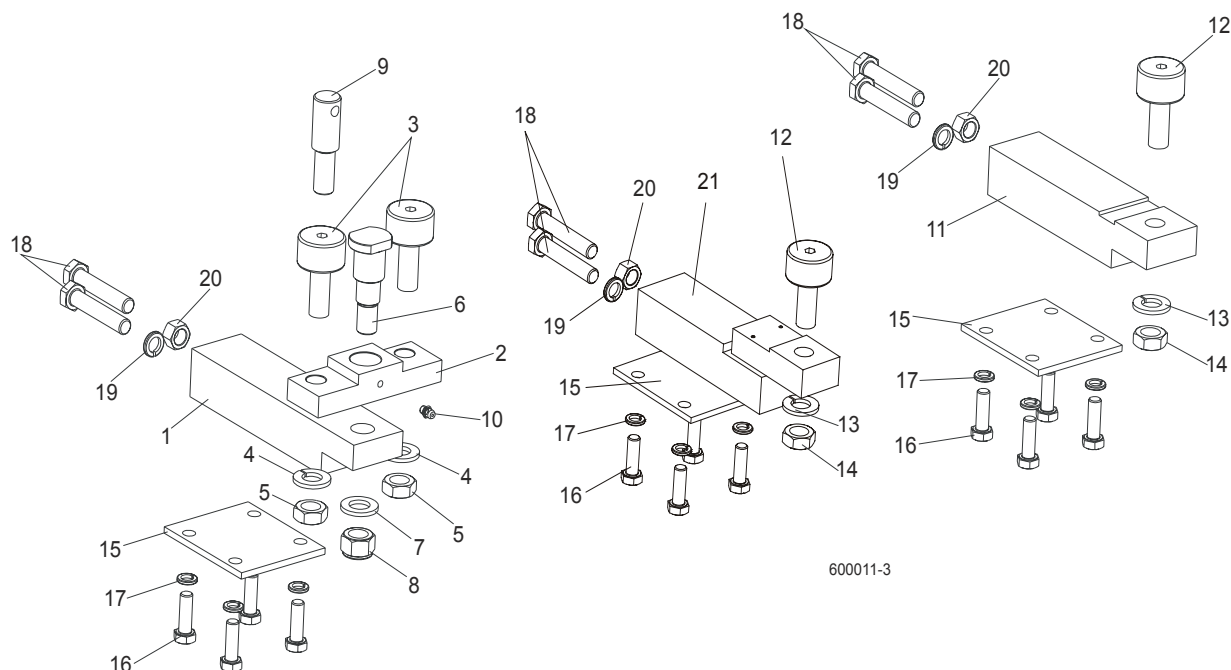

REF	DESCRIPTION (◆ Indicates Parts Available In Assemblies Only)	PART #	QTY.
	BLOCK ASSEMBLY, VERTICAL MAST ALIGNMENT DOUBLE	088523	1
1	Block, Vertical Mast Alignment Double	088517	1
2	Block, Cam Follower Mount	088520	1
3	Bearing, Cam Follower (McGill)	012797	2
4	Washer, 16.3 Split Zinc Lock	F81058-2	2
5	Nut, 5/8"-18 Zinc	F05010-11	2
6	Pin, Cam Follower Mount	088521	1
7	Washer, 17 Zinc Flat	F81058-1	1
8	Nut, M16-8 Hex Nylon Zinc Lock	F81036-2	1
9	Pin, Safety Lock	088519	1
10	Fitting, M6 Straight Grease	086280	1
	BLOCK ASSEMBLY, VERTICAL MAST ALIGNMENT SINGLE	088524	1
11	Block, Vertical Mast Alignment Single	088518	1
12	Bearing, Cam Follower (McGill)	012797	1
13	Washer, 16.3 Split Zinc Lock	F81058-2	1
14	Nut, 5/8"-18 Zinc	F05010-11	1
15	PLATE, LOWER TRACK ROLLER RETAINER	088516	3
16	BOLT, M10X30-5.8 HEX HEAD FULL THREAD ZINC	F81003-2	12
17	WASHER, 10.2 SPLIT ZINC LOCK	F81055-2	12
18	BOLT, M12X1.25X65-8.8 HEX HEAD FULL THREAD ZINC	F81004-40	6
19	WASHER, Z12.2 SPLIT ZINC LOCK	F81056-2	3
20	NUT, M12X1.25-8 ZINC HEX	F81034-8	3
21	BLOCK WELDMENT, LOWER TRACK ROLLER MOUNT	091425	1

SECTION 8 BED FRAME ASSEMBLY

8.1 Bed Rail Assembly, Rear

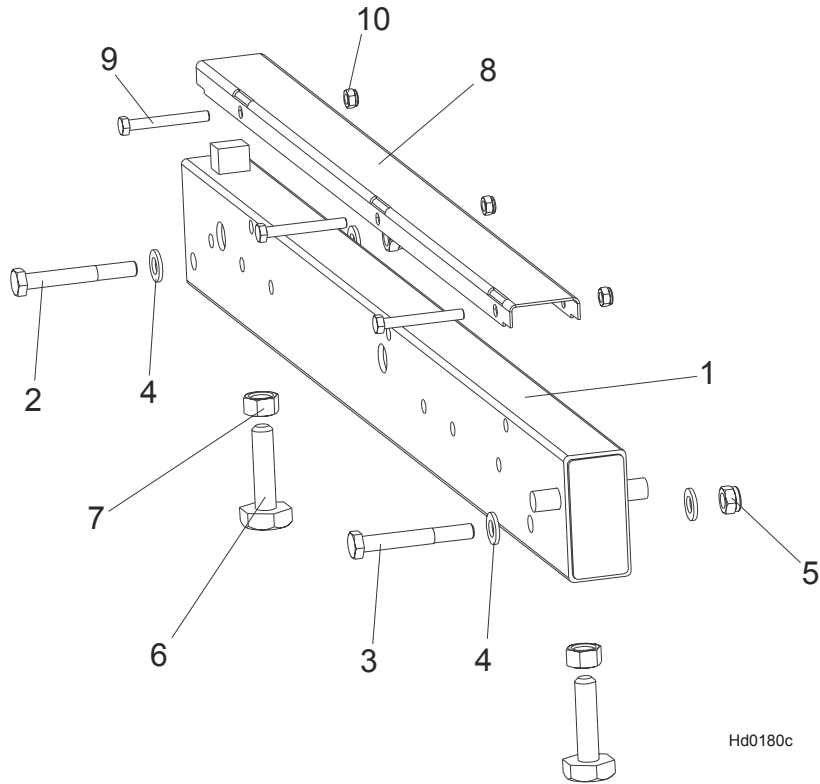

REF	DESCRIPTION (◆ Indicates Parts Available In Assemblies Only)	PART #	QTY.
1	BED RAIL ASSEMBLY, REAR PAINTED	091555	1
2	Bolt, M12 x 90-8.8 Hex Head	F81004-2	1
3	Bolt, M12 x 95-8.8 Hex Head	F81004-29	1
4	Washer, 13 SAE Flat	F81056-1	4
5	Nut, M12-8 Hex Nylon Lock	F81034-2	2
	Bed Rail Bolt, Complete (M16 Bolt + 2xNut)	093710	2
6	Bolt, M16 Bed Rail Adjustment	086809	1
7	Nut, M16-5-B Zinc Hex Head	F81036-5	2
8	COVER, STAINLESS STEEL BED RAIL	099124	1
9	BOLT, M8X65-5.8 ZINC HEX HEAD	F81002-3	3
10	NUT, M8-8-B HEX NYLON ZINC LOCK	F81032-2	3

8 Bed Frame Assembly

Bed Rail Assembly, Front Middle

8.2 Bed Rail Assembly, Front Middle

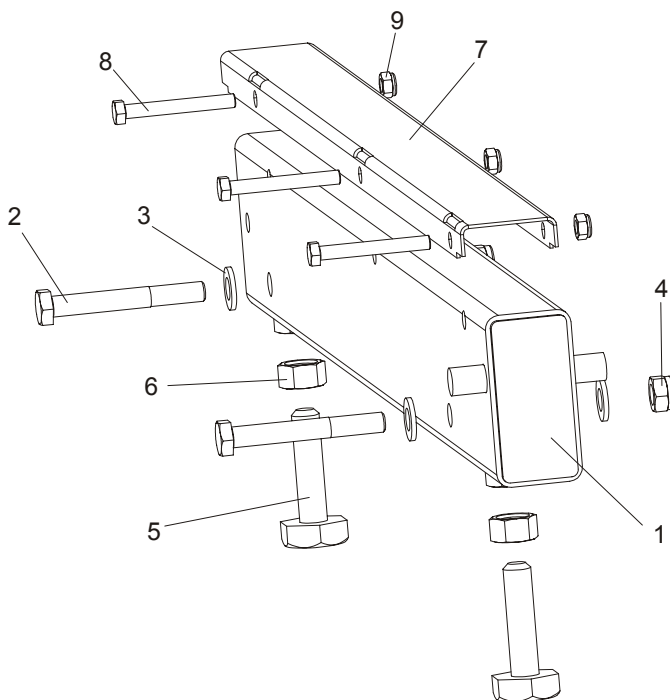

REF	DESCRIPTION (◆ Indicates Parts Available In Assemblies Only)	PART #	QTY.	
1	BED RAIL ASSEMBLY, FRONT MIDDLE	091556	1	
2	Bolt, M12 x 90-8.8 Hex Head	F81004-2	2	
3	Washer, 13 SAE Flat	F81056-1	4	
4	Nut, M12-8 Hex Nylon Lock	F81034-2	2	
	Bed Rail Bolt, Complete (M16 Bolt + 2xNut)	093710	2	
5	Bolt, M16 Bed Rail Adjustment	086809	1	
6	Nut, M16-5-B Hex Head Zinc	F81036-5	2	
7	COVER, STAINLESS STEEL BED RAIL	099124	1	
8	BOLT, M8X65-5.8 ZINC HEX HEAD	F81002-3	3	
9	NUT, M8-8-B HEX NYLON ZINC LOCK	F81032-2	3	

8.3 Bed Rail Assembly, Rear Middle

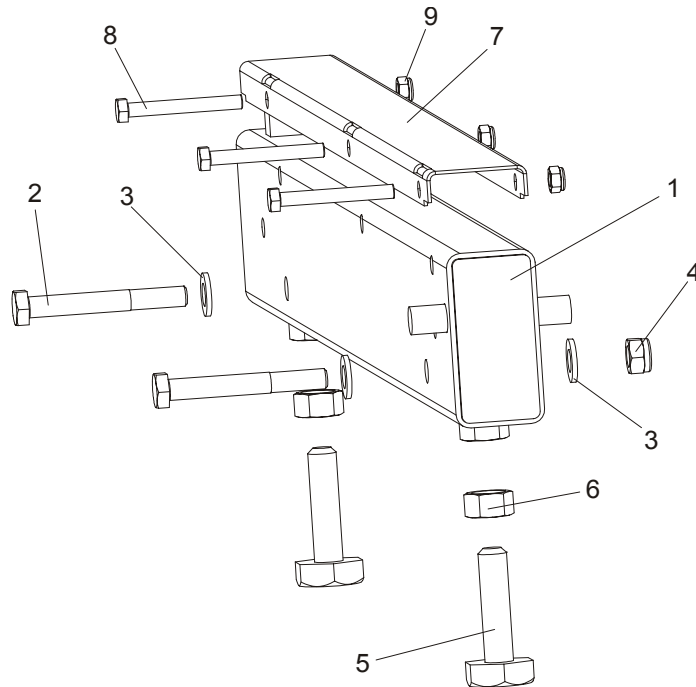

REF	DESCRIPTION (◆ Indicates Parts Available In Assemblies Only)	PART #	QTY.
1	BED RAIL ASSEMBLY, REAR MIDDLE PAINTED	091557	1
2	Bolt, M12 x 90-8.8 Hex Head	F81004-2	2
3	Washer, 13 SAE Flat	F81056-1	4
4	Nut, M12-8 Hex Nylon Lock	F81034-2	2
	Bed Rail Bolt, Complete (M16 Bolt + 2xNut)	093710	2
5	Bolt, M16 Bed Rail Adjustment	086809	1
6	Nut, M16-5-B Hex Head Zinc	F81036-5	2
7	COVER, STAINLESS STEEL BED RAIL	099124	1
8	BOLT, M8X65-5.8 HEX HEAD ZINC	F81002-3	3
9	NUT, M8-8-B HEX NYLON ZINC LOCK	F81032-2	3

8.4 Clamp Mount Assembly, Front (A/DH5/7)

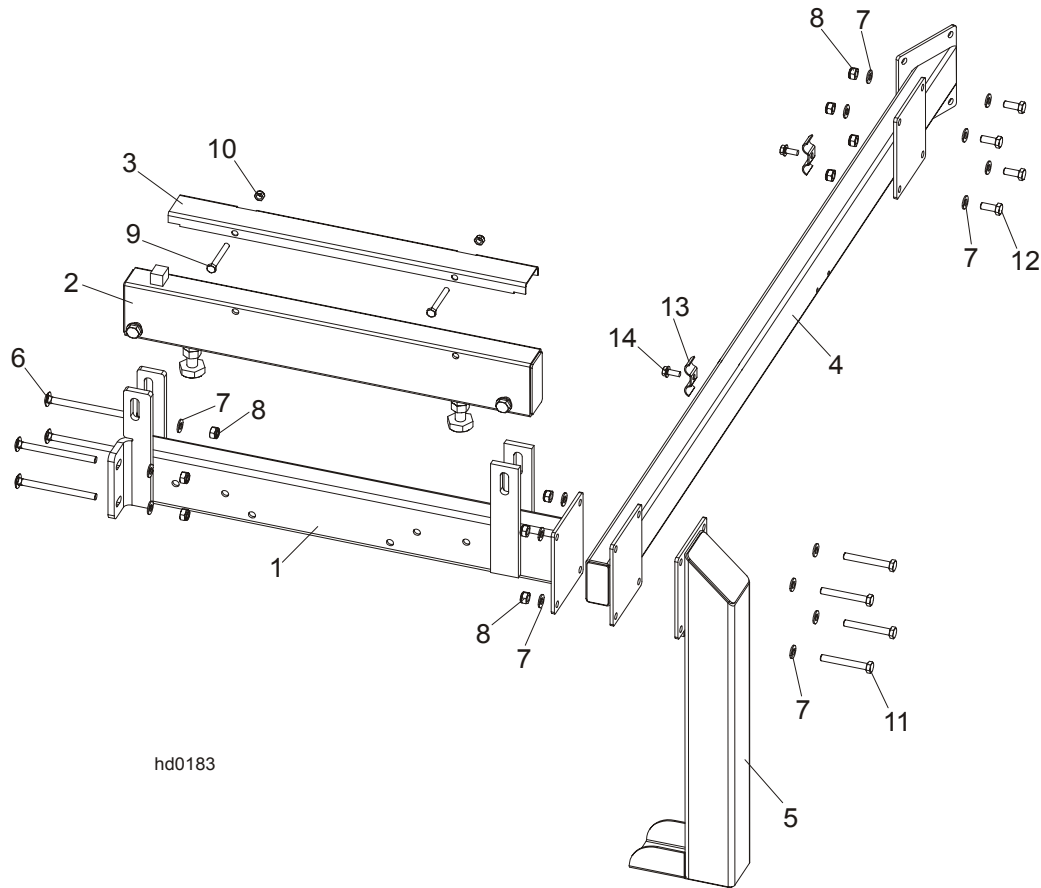

hd0183

REF	DESCRIPTION (◆ Indicates Parts Available In Assemblies Only)	PART #	QTY.
	CLAMP MOUNT ASSEMBLY - FRONT	092937	1
1	Bed Rail Assembly, Front	092903-1	1
2	Bed Rail AH5/DH5	095131-1	1
3	Cover, 22.75 SS LT50 Pivot	099123	1
4	Tube Weldment, Bed Front	092904-1	1
5	Leg, Stationary Left	087450-1	1
6	Bolt, M10 X 125-8.8 Carriage Head	F81003-34	4
7	Washer, M10 Flat Zinc	F81055-1	20
8	Nut, M10 Hex Nylon Zinc Lock	F81033-1	12
9	Bolt, M8 x 65mm Hex Head Zinc Grade 5.8	F81002-3	2
10	Nut, M8 Hex Nylon Zinc Lock	F81032-2	2
11	Bolt, M10x75-8.8 Hex Head Zinc	F81003-15	4
12	Bolt, M10-1.5x25mm Hex Head Grade 8.8	F81003-11	4
13	Plate, 1/4 Hose Clamp Painted	S09245	2
14	Screw, 5/16-18x3/4 Self-tapping	F05015-30	2

8.5 Clamp Mount Assembly, Rear (A/DH5/7)

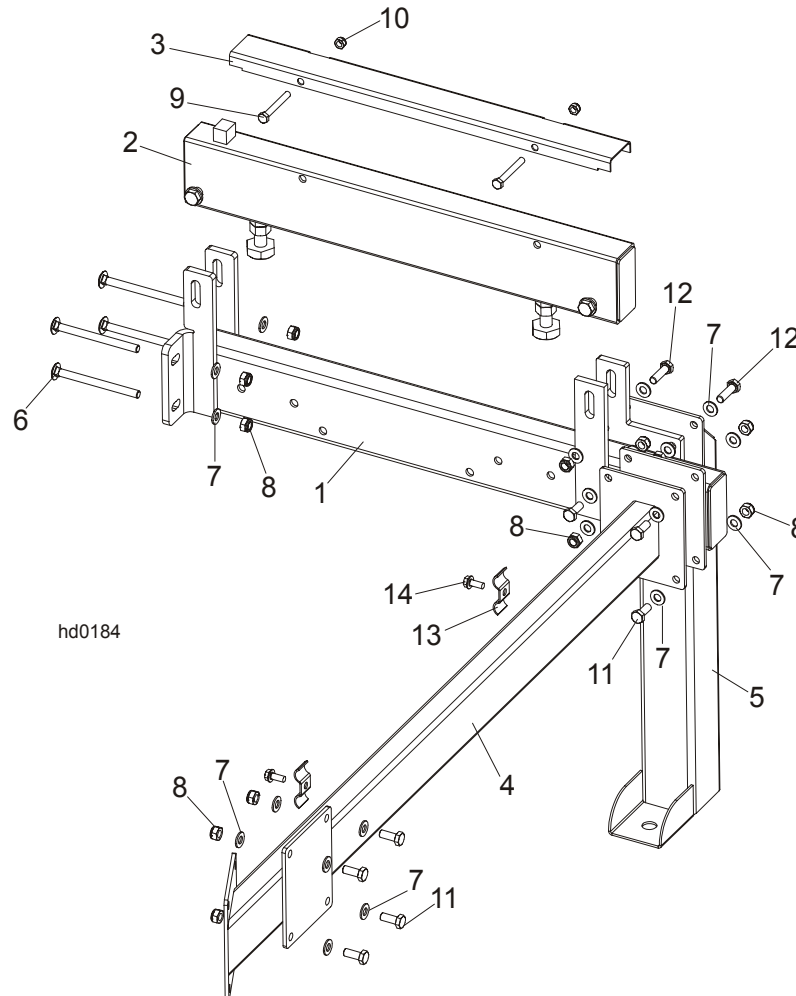

REF	DESCRIPTION (◆ Indicates Parts Available In Assemblies Only)	PART #	QTY.
	CLAMP MOUNT ASSEMBLY - REAR	092938	1
1	Bed Rail Assembly, Rear	092902-1	1
2	Bed Rail AH5/DH5	095131-1	1
3	Cover, 22.75 SS LT50 Pivot	099123	1
4	Tube Weldment, Bed Rear	092907-1	1
5	Leg, Stationary Left	087450-1	1
6	Bolt, M10 X 125-8.8 Carriage Head	F81003-34	4
7	Washer, M10 Flat Zinc	F81055-1	28
8	Nut, M10 Hex Nylon Zinc Lock	F81033-1	16
9	Bolt, M8 x 65-5.8 Hex Head Zinc	F81002-3	2
10	Nut, M8 Hex Nylon Lock Zinc	F81032-2	2
11	Bolt, M10x25-8.8Hex Head Full Thread Zinc	F81003-11	4
12	Bolt, M10x35-8.8 Hex Head Full Thread Zinc	F81003-17	4
13	Plate, 1/4 Hose Clamp Painted	S09245	2

8**Bed Frame Assembly***Clamp Mount Assembly, Rear (A/DH5/7)*

14	Screw, 5/16-18x3/4 Self-tapping	F05015-30	2	
----	---------------------------------	-----------	---	--

8.6 Leg, Stationary

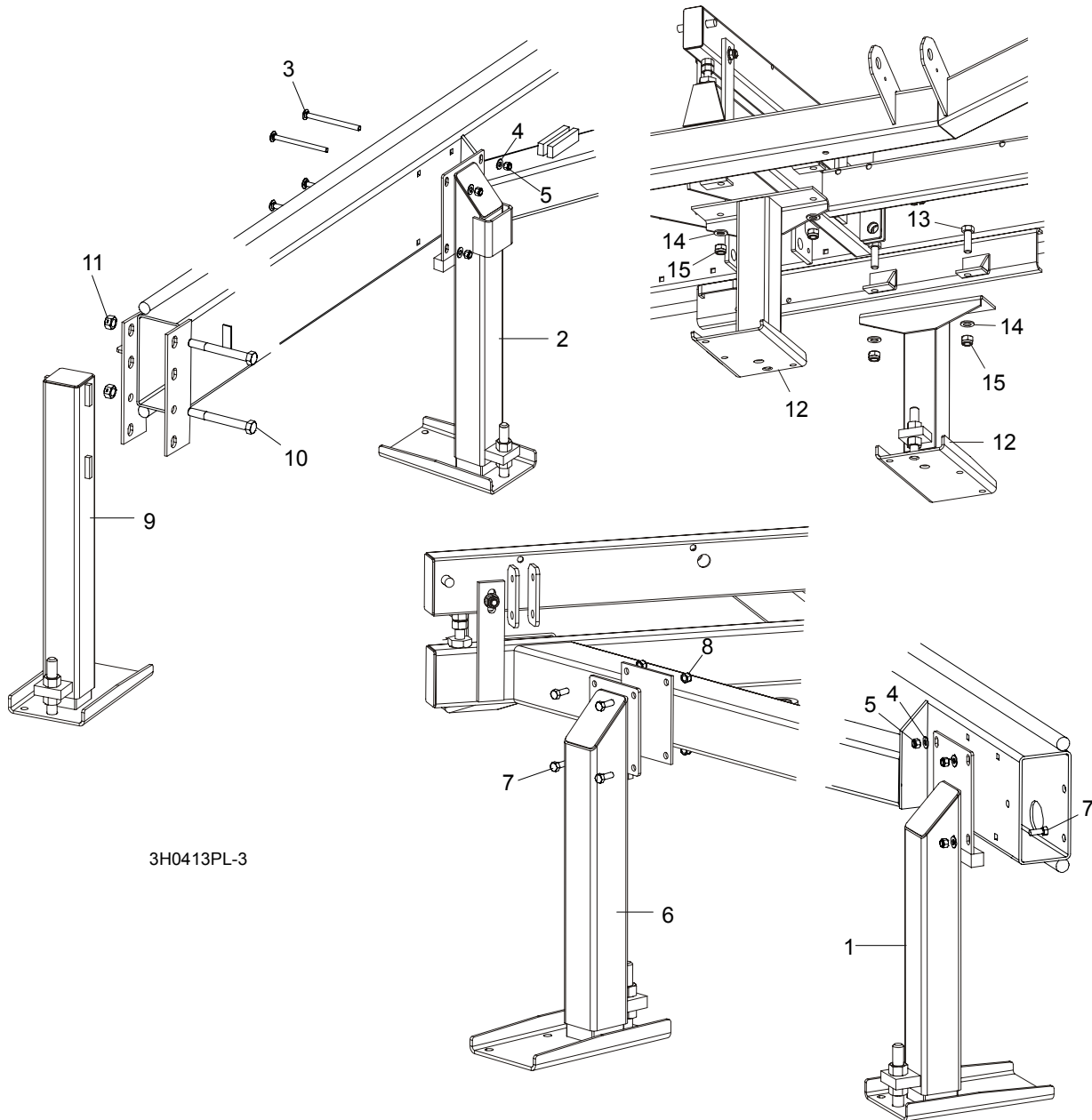

3H0413PL-3

REF	DESCRIPTION (◆ Indicates Parts Available In Assemblies Only)	PART #	QTY.
1	LEG, OUTRIGGER STATIONARY RIGHT (1 REQ'D FOR LT70S; 3 REQ'D FOR LT70M)	501640	1/3
2	LEG, OUTRIGGER STATIONARY W/BOARD RETURN TABLE BRACKET	501638	1
3	BOLT, M10 X 120-8.8 CARRIAGE HEAD	F81003-33	8/12
4	WASHER, 10.5 FLAT	F81055-1	8/16
5	NUT, M10-8-B HEX NYLON LOCK	F81033-1	8/16
6	LEG, OUTRIGGER STATIONARY LEFT	501639	2
7	BOLT, M10 X 25-8.8 HEX HEAD	F81003-11	12

8**Bed Frame Assembly***Leg, Stationary*

8	NUT, M10-8-B HEX NYLON LOCK	F81033-1	12	
9	LEG, OUTRIGGER STATIONARY FRONT	501641	1	
10	BOLT, M16 X 140-8.8 HEX HEAD GRADE 5	F81006-4	2	
11	NUT, M16-8 HEX LOCK ZINC LOCK	F81036-2	2	
12	LEG, OUTRIGGER STATIONARY MIDDLE	501637	2	
13	BOLT, M16 X 50-8.8 HEX HEAD FULL THREAD ZINC	F81006-7	4	
14	WASHER, 17 FLAT ZINC	F81058-1	4	
15	NUT, M16-8 HEX NYLON ZINC LOCK	F81036-2	4	

8.7 Pivot Bed Rail Assembly

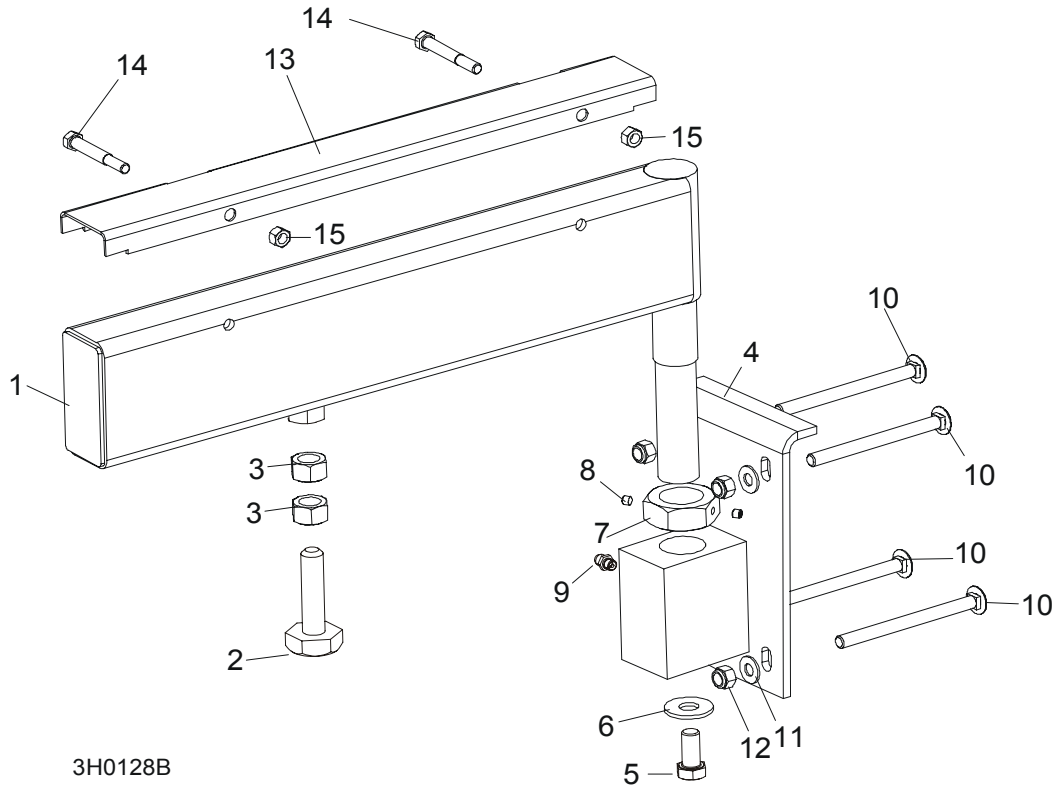

REF	DESCRIPTION (◆ Indicates Parts Available In Assemblies Only)	PART #	QTY.
	PIVOT BED RAIL ASSEMBLY	087829	2
	PIVOT BED RAIL ASSEMBLY	087855	2
1	Pivot Bed Rail Weldment	087852	1
	Pivot Bed Rail Weldment	087848	1
	Bolt Assembly, Bed Rail Adjustment		1
2	Bolt, Bed Rail Adjustment	086809	1
3	Nut, M16-5.8 Hex Zinc	F81036-1	2
4	Bracket, Pivot Rail Mounting	087841-1	1
5	Bolt, M12x25-8.8 Hex Head Full Thread Zinc	F81004-31	1
6	Washer, 15 Flat	F05011-52	1
7	Nut, Pivot Rail Adjustment Nut, Pivot Rail Adjustment	F81036-1 F81039-2	1
8	Screw, 1/4-28 x 1/4" Brass Tip Set	F05005-42	2
9	Fitting, 3/16" Grease	086280	1
10	BOLT, 3M10 X 120-8.8 CARRIAGE HEAD	F81003-14	2
11	BOLT, 3/8-16 X 5" CARRIAGE HEAD	F05007-113	6
12	WASHER,10.5 FLAT ZINC	F81055-1	8
13	NUT, M16-8 HEX NYLON ZINC LOCK	F81036-2	8

8

Bed Frame Assembly

Log Side Support Assembly (Manual)

	COVER KIT, PIVOT RAIL STAINLESS STEEL	015926	2	
	COVER KIT, PIVOT RAIL STAINLESS STEEL	N/A	2	
14	Cover, Stainless Steel Pivot Bed Rail	012994	1	
	Cover, Stainless Steel Pivot Bed Rail	099123	1	
15	Bolt, M8x65-5.8 Hex Head Zinc	F81002-3	4	
16	Nut, M8-8-B Hex Nylon Zinc Lock	F81032-2	4	
	WRENCH, BED RAIL ADJUSTMENT (See Section 8.3)	015970	1	

8.8 Log Side Support Assembly (Manual)

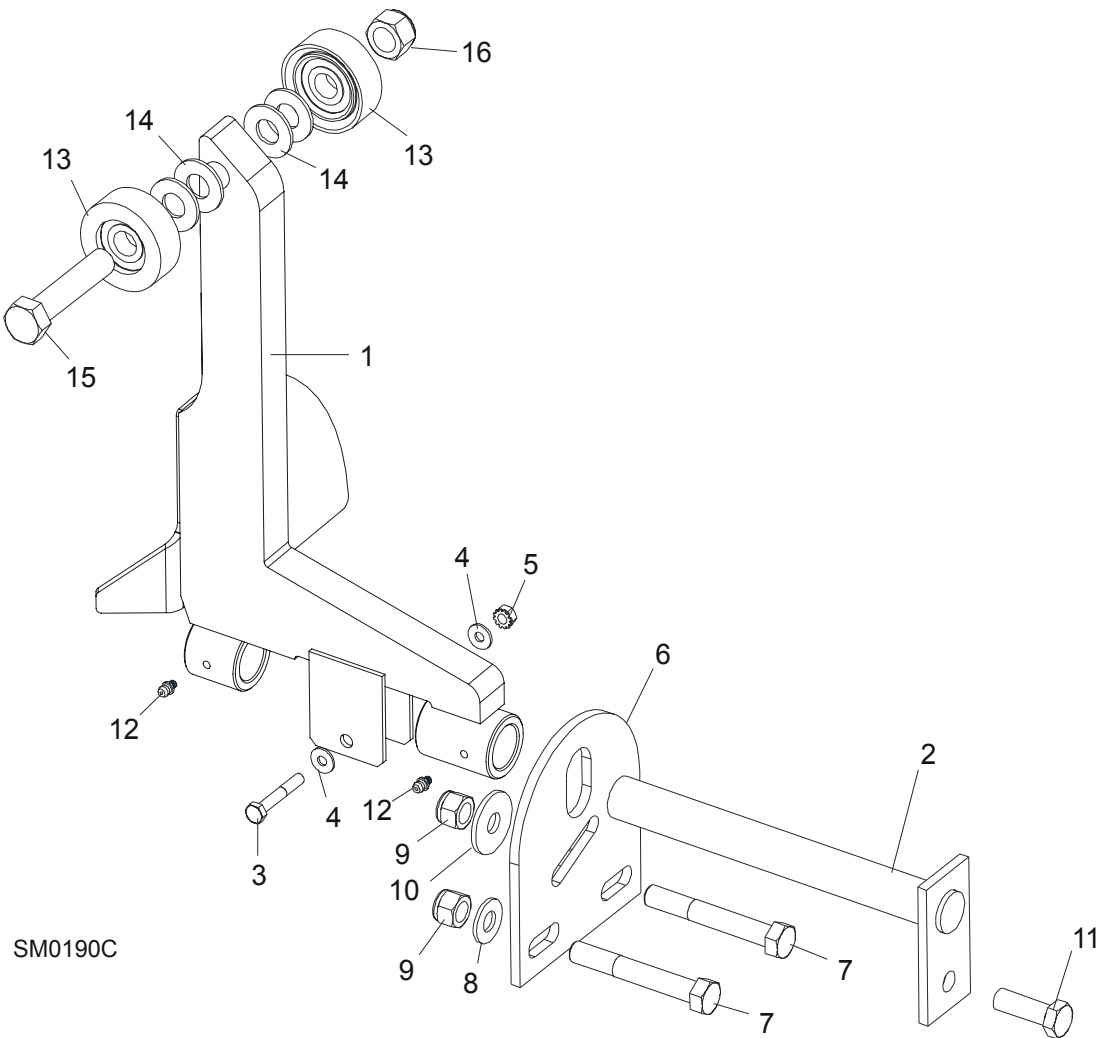

REF	DESCRIPTION (◆ Indicates Parts Available In Assemblies Only)	PART #	QTY.	
1	SUPPORT, LOG SIDE W/GUARD	099785-1	1	
2	PIN, LOG SIDE SUPPORT PIVOT	091549-1	1	
3	BOLT, M8X45-8.8 HEX HEAD FULL THREAD ZINC	F81002-14	1	
4	WASHER, 8.4 FLAT ZINC	F81054-1	2	
5	NUT, M8-8-B HEX NYLON ZINC LOCK	F81032-2	1	

6	PLATE, LOG SIDE SUPPORT END	091591-1	1	
7	BOLT, M12 X 90-8.8 HEX HEAD ZINC	F81004-2	2	
8	WASHER, 13 FLAT ZINC	F81056-1	2	
9	NUT, M12-8 HEX NYLON ZINC LOCK	F81034-2	3	
10	WASHER, .5" X 1.63" X 11" GA.	086184	1	
11	BOLT, M12 X 35-8.8 HEX HEAD FULL THREAD ZINC	F81004-24	1	
12	FITTING, 3/16" GREASE	P04107	2	
13	ROLLER ASSEMBLY, SIDE SUPPORT	015014-1	2	
14	WASHER, 17 FLAT ZINC	F81058-1	2	
15	BOLT, M16X65-8.8-B HEX HEAD FULL THREAD ZINC	F81006-1	1	
16	NUT, M16-8 HEX NYLON ZINC LOCK	F81036-2	1	
	INSTRUCTION SHEET, SIDE SUPPORT ROLLER	015109-526	1	

8.9 LT70 S/M Saw Head Rest Pin Assembly

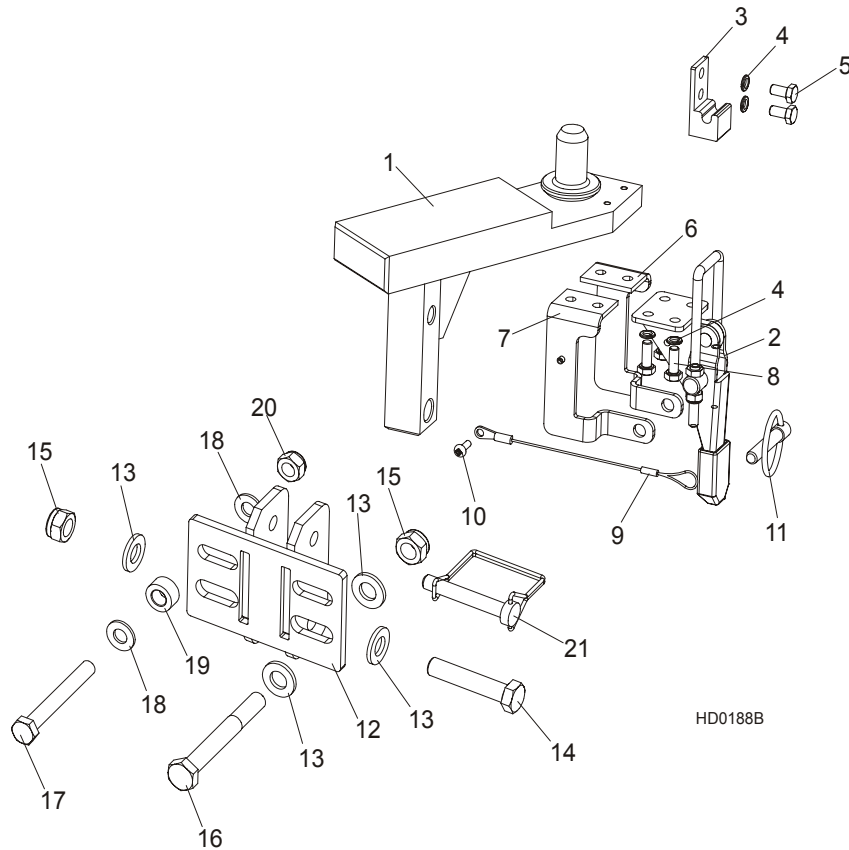

REF	DESCRIPTION (◆ Indicates Parts Available In Assemblies Only)	PART #	QTY.	
	SAW HEAD REST PIN W/LATCH CLAMP, LT70S/M	094660	1	
1	Pin Weldment, LT70S/M Saw Head Rest	094658-1	1	
2	Clamp, GN851.2-320-T4 Latch	094656	1	
3	Latch Bracket, GN851.2-320-T4 Zinc-plated	094659-1	1	
4	Washer, Z 6.1 Split Lock Zinc	F81053-3	6	

8

Bed Frame Assembly

Bed Frame Decals

5	Bolt, M6x12-8.8 Hex Head Full Thread Zinc	F81001-7	2	
6	Bracket, Locking Right	097102-1	1	
7	Bracket, Locking Left	097103-1	1	
8	Bolt, M6x16-8.8-Fe/Zn5 PN-85/M-82105	F81001-32	4	
9	Lanyard, 3/64x6"	016030	1	
10	Screw, M4x12 -5,8-B- Fe/Zn5 PN-M/82202	F81011-43	1	
11	Pin, 8 BN914(BOSSARD 1364650) Clamp Lock	F81046-2	1	
12	BRACKET, LT40 SAW HEAD REST PIN MOUNT PAINTED	092765-1	1	
13	WASHER, 13 FLAT ZINC	F81056-1	4	
14	BOLT, M12 X 60-8.8 HEX HEAD ZINC	F81004-5	1	
15	NUT, M12-8 HEX NYLON ZINC LOCK	F81034-2	2	
16	BOLT, M12x95-8.8 HEX HEAD ZINC	F81004-29	1	
17	BOLT, M10x80-8.8 HEX HEAD ZINC	F81003-50	1	
18	WASHER, 10.5 FLAT ZINC	F81055-1	2	
19	BUSHING, ZINC-PLATED SPACER	090936-1	1	
20	NUT, M10-8-B HEX NYLON ZINC LOCK	F81033-1	1	
21	PIN, 3/8" X 2 1/4" SNAP RETAINER	014151	1	

8.10 Bed Frame Decals

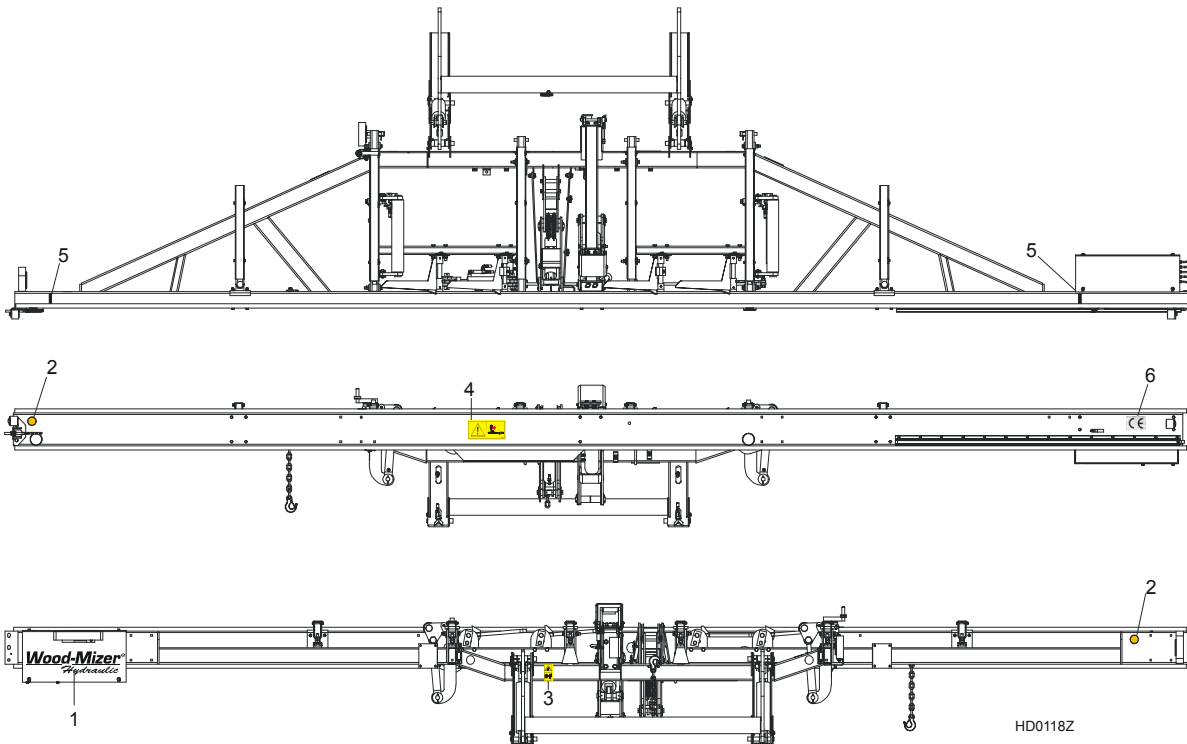

REF	DESCRIPTION (◆ Indicates Parts Available In Assemblies Only)	PART #	QTY.	
1	DECAL, WOOD-MIZER SUPER HYDRAULIC LOGO	014168	1	
2	DECAL, AMBER REFLECTIVE 2" ROUND	P07453	2	

3	DECAL, KEEP AWAY DANGER, PICTOGRAM	099221	1	
4	DECAL, SAWMILL TRAILER CAUTION, PICTOGRAM	099542	1	
5	DECAL, LOG LIMIT STRIPE	S12051	2	
6	DECAL, CE CERTIFIED SAWMILL, SMALL	P85070	1	

8.11 Tie Down Chain Assembly

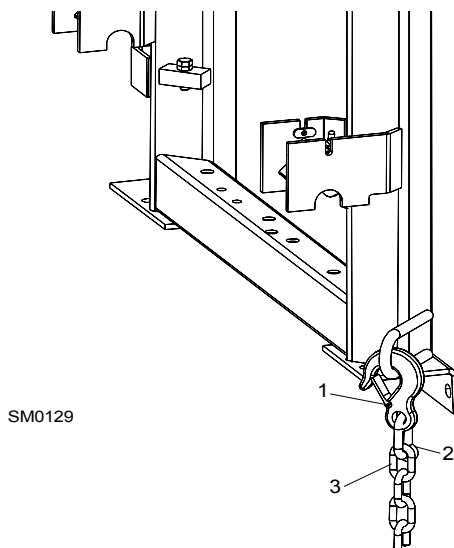

REF	DESCRIPTION (◆ Indicates Parts Available In Assemblies Only)	PART #	QTY.	
	CHAIN ASSEMBLY, TIE DOWN	A04376-1	1	
1	Hook, 5/8" Safety Chain	P12075	1	
2	Screw Closed Chain Link, 10	100767	1	
3	Chain, N-10 x 35, 6 Links	100951	1	

SECTION 9 LOG CLAMP, TURNER, LOADER & TOE BOARDS

9.1 Manual Log Clamp

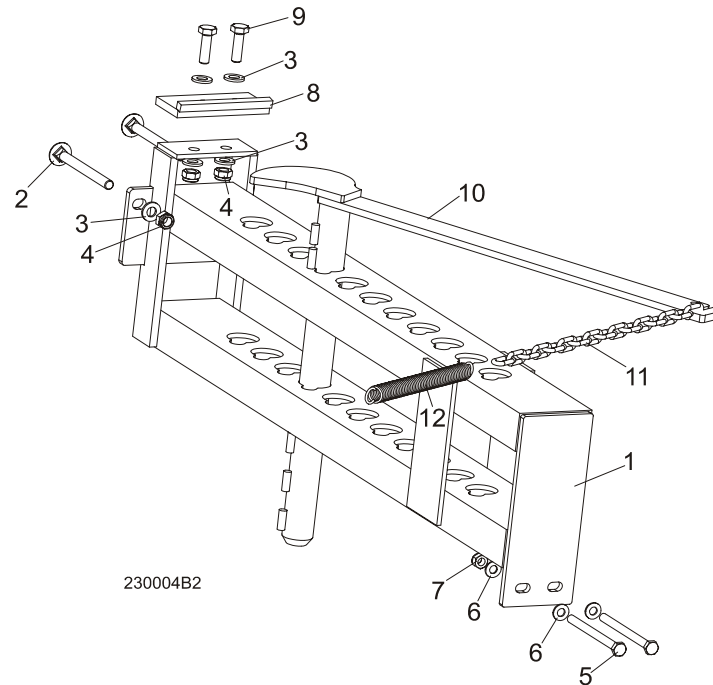

REF	DESCRIPTION (◆ Indicates Parts Available In Assemblies Only)	PART #	QTY.
	MANUAL LOG CLAMP	092683	1
1	Bracket, Manual Log Clamp	092677-1	1
2	Bolt, M12x130-8.8 Carriage Head Zinc	F81004-26	2
3	Washer, 13 Flat Zinc	F81056-1	6
4	Nut, M12-8 Hex Nylon Zinc Lock	F81034-2	4
5	Bolt, M10x125-8.8 Hex Head Zinc	F81003-18	2
6	Washer, 10.5 Flat Zinc	F81055-1	4
7	Nut, M10-8-B Hex Nylon Zinc Lock	F81033-1	2
8	Stop Weldment, Log Clamp Painted	086980-1	1
9	Bolt, M12 x 40-8.8 Hex Head Full Thread Zinc	F81004-4	2
10	Log Clamp Weldment, Manual Painted	100725-1	1
11	Chain, Log Clamp	M04311	1
12	Spring, FI 2.8 X FI 22.2 X 183	091864	1

9.2 Log Clamp Assembly

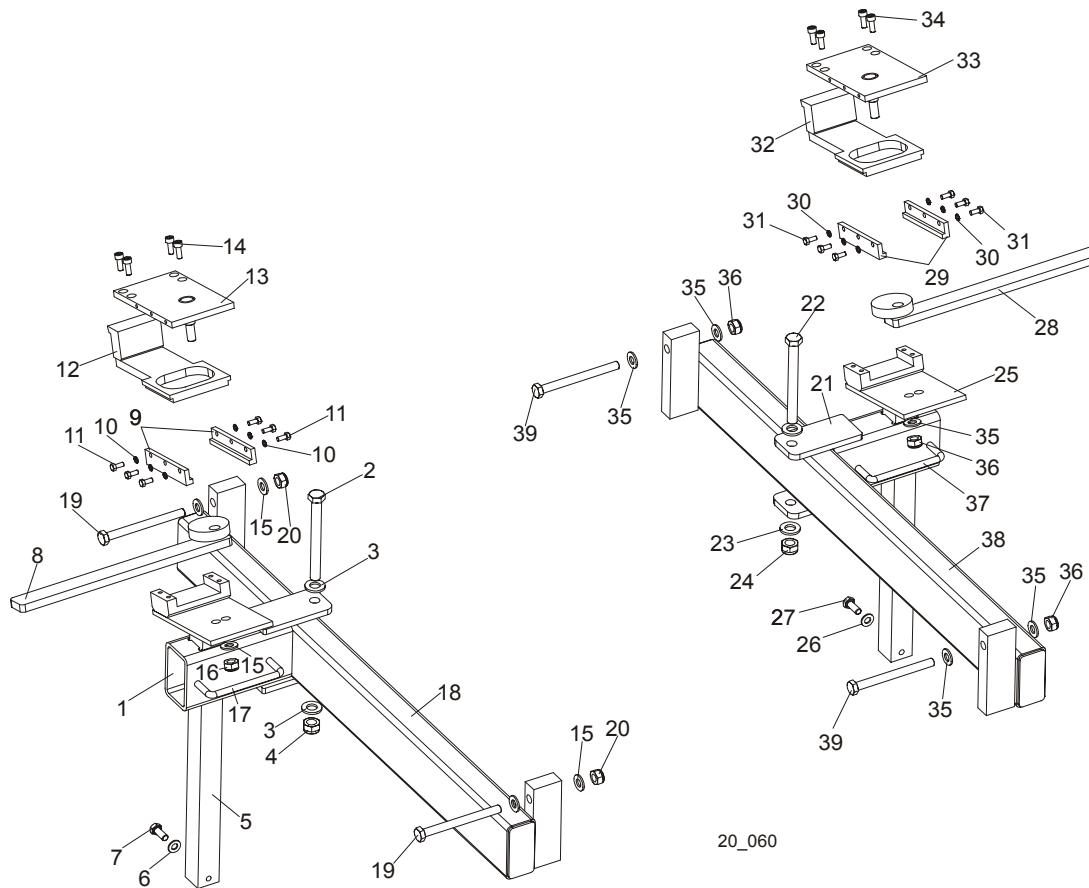

REF	DESCRIPTION (◆ Indicates Parts Available In Assemblies Only)	PART #	QTY.
	LOG CLAMP ASSEMBLY, LEFT (NON-HYDRAULIC)	089631 ¹	1
1	Arm Weldment, Log Clamp Zinc-Plated	089624-1	1
2	Bolt, M12x120 8.8 Hex Head Zinc	F81004-38	1
3	Washer, 13 Zinc Flat	F81056-1	2
4	Nut, M12-8 Hex Nylon Zinc Lock	F81034-2	1
5	Mount Weldment, Log Clamp Zinc-Plated	090174-1	1
6	Washer, 8.4 Zinc Flat	F81054-1	4
7	Bolt, M8x20-8.8-B Hex Head Full Thread Zinc	F81002-4	2
8	Lever, Log Clamp Zinc-Plated	089611-1	1
9	Plate, Log Clamp Side Zinc-Plated	089615-1	2
10	Washer, 5.1 Split Lock Zinc	F81052-2	6
11	Bolt, M5x12-5.8 Hex Head Full Thread Zinc	F81000-5	6
12	Plate, Clamping Zinc-Plated	090202-1	1
13	Plate, Log Clamp Upper Zinc-Plated	089614-1	1
14	Screw, M6x16-8.8 Hex Socket Set Cap Zinc	F81001-21	4
15	Washer, 10.5 Zinc Flat	F81055-1	5
16	Nut, M8-8-B Hex Nylon Zinc Lock	F81032-2	1
17	Handle, 4" w/Bolts	P08065	1
18	Bar Weldment, Log Clamp Guide Ptd	089628-1	1
19	Bolt, M10x110 8.8 Hex Head Zinc	F81003-43	2
20	Nut, M10-8-B Hex Nylon Zinc Lock	F81033-1	2
	LOG CLAMP ASSEMBLY, RIGHT (NON-HYDRAULIC)	090349	1
21	Arm Weldment, Log Clamp Zinc-Plated	089624-1	1

22	Bolt, M12x120 8.8 Hex Head Zinc	F81004-38	1	
23	Washer, 13 Zinc Flat	F81056-1	2	
24	Nut, M12-8 Hex Nylon Zinc Lock	F81034-2	1	
25	Mount Weldment, Log Clamp Zinc-Plated	090174-1	1	
26	Washer, 8.4 Zinc Flat	F81054-1	2	
27	Bolt, M8x20-8.8-B Hex Head Full Thread Zinc	F81002-4	2	
28	Lever, Log Clamp Zinc-Plated	090348-1	1	
29	Plate, Log Clamp Side Zinc-Plated	089615-1	2	
30	Washer, 5.1 Split Lock Zinc	F81052-2	6	
31	Bolt, M5x12-5.8 Hex Head Full Thread Zinc	F81000-5	6	
32	Plate, Clamping Zinc-Plated	090202-1	1	
33	Plate, Log Clamp Upper Zinc-Plated	090347-1	1	
34	Screw, M6x16-8.8 Hex Socket Head Cap Zinc	F81001-21	4	
35	Washer, 10.5 Zinc Flat	F81055-1	5	
36	Nut, M10-8-B Hex Nylon Zinc Lock	F81033-1	3	
37	Handle, 4" w/Bolts	P08065	1	
38	Bar Weldment, Log Clamp Guide Ptd	089628-1	1	
39	Bolt, M10x110 8.8 Hex Head Zinc	F81003-43	2	

¹ The number of clamps depends on the frame length.

9.3 Manual Log Turner

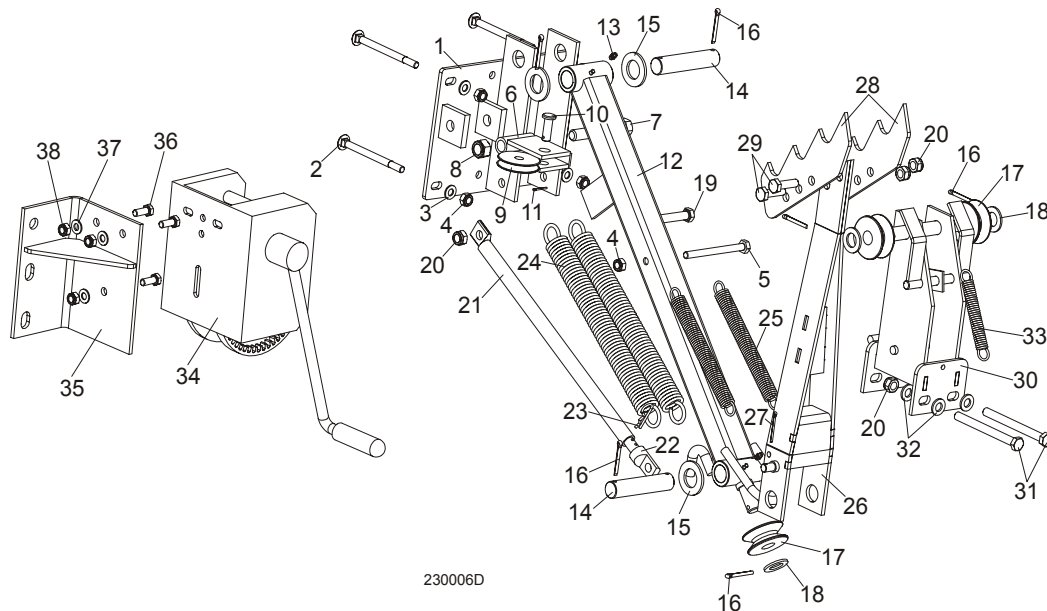

REF	DESCRIPTION (◆ Indicates Parts Available In Assemblies Only)	PART #	QTY.
	MANUAL LOG TURNER OPTION (S/M TYPE FRAME)	091291	1
	MANUAL LOG TURNER OPTION (L TYPE FRAME)	091562	1
1	Bracket Weldment, Manual Log Turner Painted (S/M Type Frame)	091269-1	1
	Bracket Weldment, Manual Log Turner Painted (L Type Frame)	090271-1	1
2	Bolt, M10x120 8.8 Carriage Head Zinc	F81003-33	4
3	Washer, 10.5 Flat Zinc	F81055-1	4
4	Nut, M10-8-B Hex Nylon Zinc Lock	F81033-1	5
5	Bolt, M10x115-8.8 Hex Head Zinc	F81003-19	1
6	Bracket Weldment, Cable Guide Pulley Painted	091295-1	1
7	Bolt, M16x100-8.8 Hex Head Full Thread Zinc	F81006-2	1

8	Nut, M16-8 Hex Nylon Zinc Lock	F81036-2	1	
9	Pulley, Zinc-Plated Cable Guide	091273-1	1	
10	Pin, 12x35 B Clevis Zinc	F81049-1	1	
11	Pin, 2.5x20 Cotter Zinc	F81043-1	1	
12	Arm Weldment, Manual Turner Lower Painted	091256-1	1	
13	Fitting, M6 Grease	086280	2	
14	Pin, Manual Turner Arm Pivot Zinc-Plated	091275-1	2	
15	Washer, 28 Flat Zinc	F81061-1	4	
16	Pin, 5x40 Cotter Zinc	F81043-31	7	
17	Pulley, Manual Turner Zinc-Plated	091280-1	3	
18	Washer, 20.5 Split Lock Zinc	F81059-1	5	
19	Bolt, M12x120 8.8 Hex Head Zinc	F81004-38	1	
20	Nut, M12-8 Hex Nylon Zinc Lock	F81034-2	5	
21	Tube, Manual Turner Painted	091537-1	1	
22	Rod Weldment, Manual Turner Painted	091540-1	1	
23	Pin, 1/8x1 13/16 Safety	P05059	1	
24	Spring, FI 4.5 x FI 35 x 303	091863	2	◆
25	Spring, FI 2.8 x FI 22.2 x183	091864	2	
26	Arm Weldment, Manual Turner Upper Painted	091263-1	1	
27	Pin, 4x25 Cotter Zinc	F81043-2	1	
28	Claw, Log Turner Painted	088082-1	2	
29	Bolt, M12x40-8.8 Hex Head Full Thread Zinc	F81004-4	2	
30	Bracket Weldment, Manual Turner Pulley Painted	091281-1	1	
31	Bolt, M12x130-8.8 Hex Head Zinc	F81004-36	2	
32	Washer, 13 Flat Zinc	F81056-1	4	
33	Spring, FI 1.9 X FI 14.2 X 104	091865	1	
34	WINCH, AL-KO TYPE 901	096453	1	
35	BRACKET, WINCH MOUNT (COMP. NON-HYD FRAME)	085841-1	1	
36	BOLT, M10-1.5X25MM HH GR8.8	F81003-11	3	
37	WASHER, FLAT, M10, ZINC	F81055-1	3	
38	NUT, M10, NYLON HEX ZINC LOCK	F81033-1	3	

9.4 Manual Toe Board

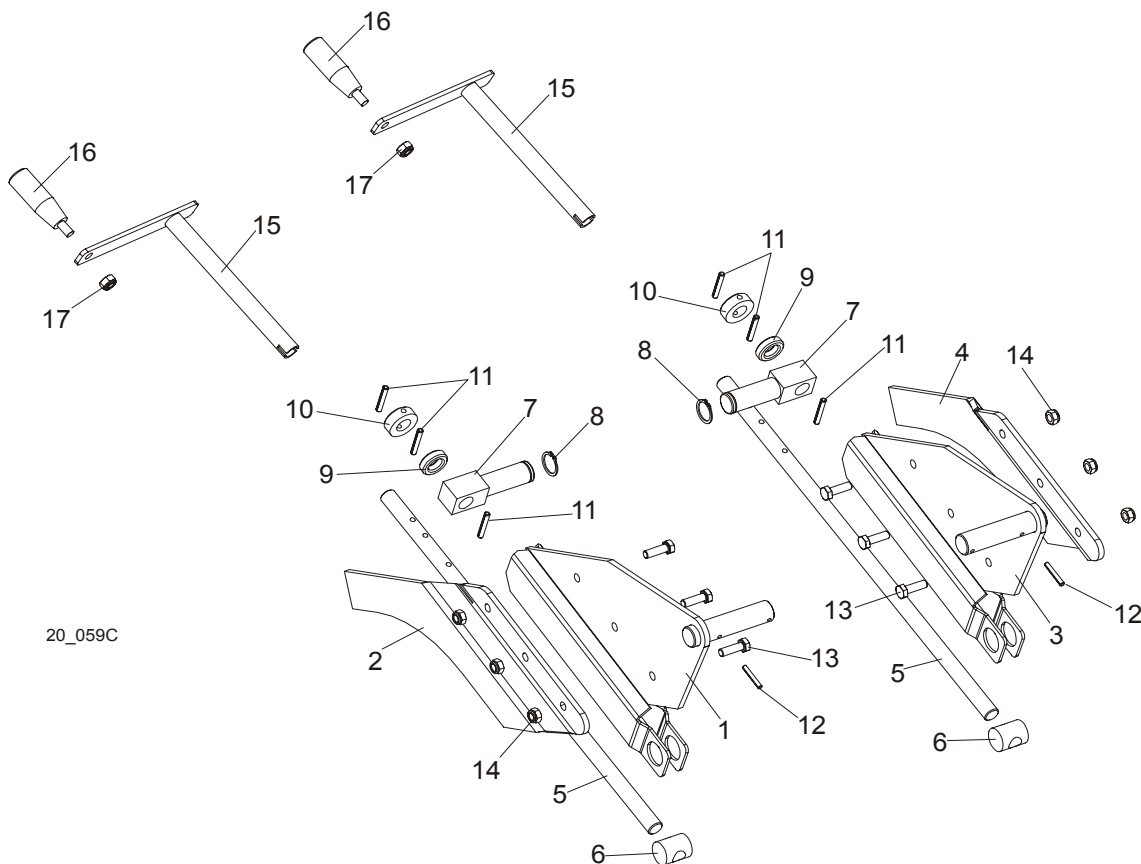

REF	DESCRIPTION (◆ Indicates Parts Available In Assemblies Only)	PART #	QTY.
	TOE BOARD KIT, MANUAL FRONT	094929	1
1	Plate Weldment, Manual Toe Board Front	094927-1	1
2	Extension, Manual Toe Board Plate (I)	095203-1	1
	TOE BOARD KIT, MANUAL REAR	094928	1
3	Plate Weldment, Manual Toe Board Rear	094926-1	1
4	Extension, Manual Toe Board Plate (II)	095202-1	1
5	Shaft, Manual Toe Board	090344-1	2
6	Nut, Special Threaded	090017	2
7	Pivot Manual Toe Board Shaft (I)	094931-1	2
8	Ring, Z 22 Outside Retaining	F81090-24	2
9	Bearing, 5/8" Thrust	P04214	2
10	Collar, 16	F81039-6	2
11	Pin, 5x35-N-C PN-EN ISO 8752 Roll	F81044-9	6
12	Pin, 4x30 Zinc Roll	F81044-7	2
13	Bolt, M8 x 25-8.8-B Hex Head Full Thread Zinc	F81002-5	6
14	Nut, M8-8-B Hex Nylon Zinc Lock	F81032-2	6
	CRANK ASSEMBLY, MANUAL TOE BOARD	500600	2
15	Crank, Manual Toe Board	500599-1	1
16	Knob, Plastic Crank Handle	086338	1
17	Nut, M10-8-B Nylon Hex Zinc Lock	F81033-1	1

9.5 Manual Log Loader (S/M Type Frame)

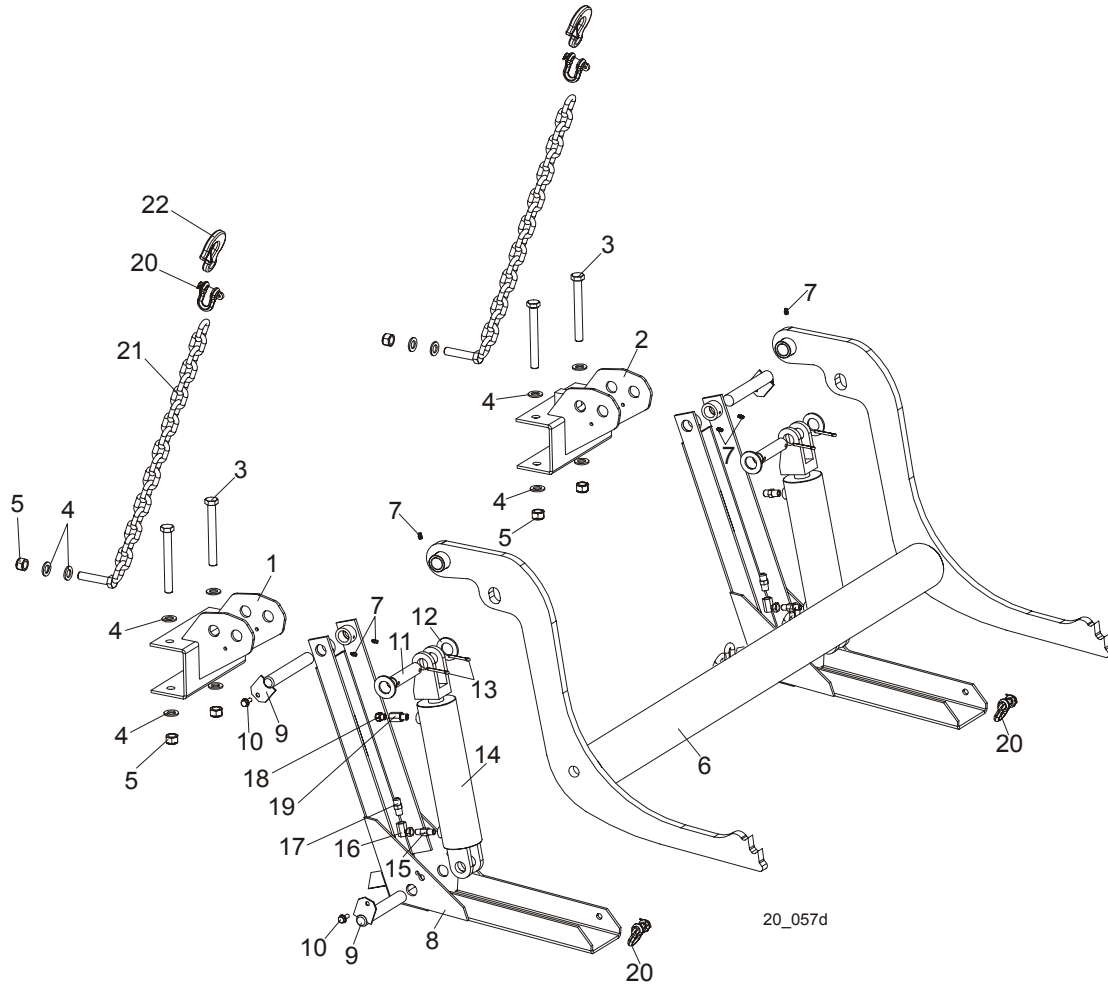

20_057d

REF	DESCRIPTION (◆ Indicates Parts Available In Assemblies Only)	PART #	QTY.
	LOG LOADER, COMPLETE	091952	1
1	Bracket , Log Loader Mount Painted (S/M Type Frame)	092865-1	1
2	Bracket, Log Loader Mount	091938-1	1
3	Bolt, M16x140-8.8 Hex Head Zinc	F81006-4	4
4	Washer, 17 Zinc Flat	F81058-1	12
5	Nut, M16-8 Hex Nylon Zinc Lock	F81036-2	6
	Log Loader W/Chain	091954	1
6	Loader Weldment, Log Painted	090006-1	1
7	Fitting, 3/16" Straight Grease	P04107	6
8	Foot, Log Loader Painted	090048-1	2
9	Pin Weldment, Log Loader Painted	W09446-1	4
10	Screw, 5/16-18 x 3/4 Self-Tapping	F05015-30	4
11	Pin, Hydraulic Cylinder Zinc-Plated	086979-1	2
12	Washer, 28 Zinc Flat	F81061-1	4
13	Pin, 5x40 Cotter	F81043-31	4
	Cylinder Assembly, Log Loader	094333	2
14	Cylinder, CJ-S95-16-70/32/203 Hydraulic	088680	1
15	Fitting, 1/4 NPT 4.0 GPM Velocity Fuse	015750	1
16	Fitting, #9455X4X4 90 Deg. Swivel Elbow	P12199	1
17	Fitting, 3/8JIC-1/4 NPT Straight	015560	1

18	Air Vent Valve 2901-14-17	090794	1	
19	Fitting, $\frac{1}{4}$ " F. Thread/ $\frac{1}{4}$ " NPT M. Thread Reducer	090795	1	
20	Shackle, M-WL. .63	099525	4	
21	Chain, Log Loader Painted	091953-1	2	
22	Hook, 5/8 Safety Chain	P12075	2	

9.6 Manual Log Loader Pump

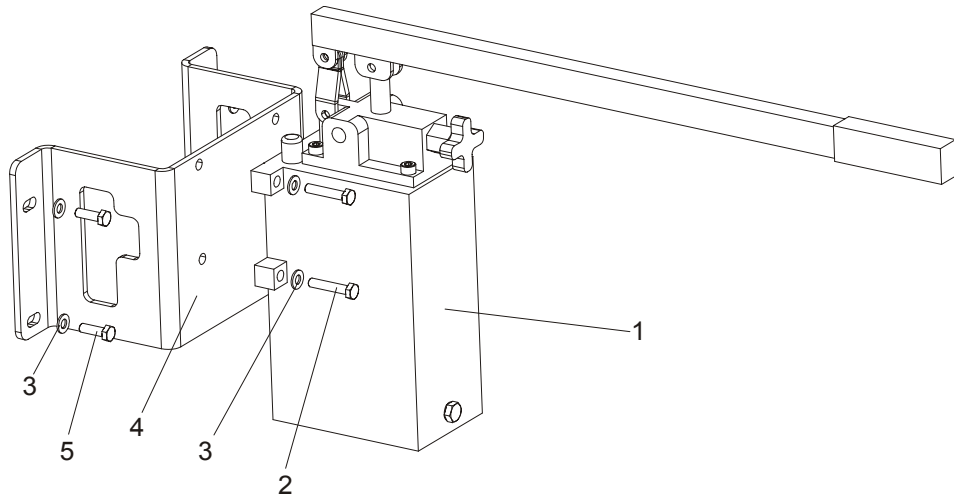

REF	DESCRIPTION (◆ Indicates Parts Available In Assemblies Only)	PART #	QTY.	
1	PUMP, PAM 014 2500 3L MANUAL	090309	1	
2	BOLT, M8X80-8.8 HEX HEAD ZINC	F81002-18	4	
3	WASHER, 8.4 ZINC FLAT	F81054-1	8	
4	BRACKET, LOG LOADER PUMP MOUNT	090377-1	1	
5	BOLT, M8X25-8.8-B HEX HEAD FULL THREAD ZINC	F81002-5	4	